

VPCエニーキャストゲートウェイを使用したSR MPLSでのNexus L2 EVPNの設定

内容

[概要](#)

[前提条件](#)

[要件](#)

[使用するコンポーネント](#)

[背景説明](#)

[設定](#)

[ネットワーク図](#)

[ハイレベル設定](#)

[確認](#)

[トラブルシューティング](#)

概要

このドキュメントでは、Nexus9Kで仮想ポートチャネルを使用してL2 Ethernet VPN(LVPN) over Segment Routing(SR)マルチプロトコルラベルスイッチング(MPLS)を展開する方法について説明します。

前提条件

要件

次の項目に関する知識があることが推奨されます。

- ボーダー ゲートウェイ プロトコル (BGP)
- Open Shortest Path First (OSPF)
- MPLS
- ラベル配布プロトコル(LDP)
- Resource Reservation Protocol (RSVP)
- EVPN
- SR
- vPC

使用するコンポーネント

このドキュメントの情報は、次のソフトウェアとハードウェアのバージョンに基づいています。:

- H1およびH3用にリリース9.3(10)を実行するNexusスイッチ92360C。
- スパイン用のリリース10.2(3)を実行するNexusスイッチ93180YC-FX(FX)。
- Leaf用にリリース10.2(3)を実行するNexusスイッチ93240YC。

このドキュメントの情報は、特定のラボ環境にあるデバイスに基づいて作成されました。このドキュメントで使用するすべてのデバイスは、初期（デフォルト）設定の状態から起動しています。本稼働中のネットワークでは、各コマンドによって起こる可能性がある影響を十分確認してください。

背景説明

VPLS/L2-EVPNは、IP/MPLSネットワーク上の単一の論理スイッチドアーキテクチャで、顧客の複数のブランチを接続するマルチポイントツーマルチポイントレイヤ2 VPNサービスです。

Layer2 EVPN-MPLS SRの概要

EVPN(RFC 7432)は、BGP MPLSベースのソリューションで、仮想化データセンターネットワークの次世代イーサネットサービスに使用されています。既存のMPLSテクノロジーのRoute Distinguisher(RD)、Route Target(RT)、Virtual Routing and Forwarding(VRF)などの複数のブロックを使用します。

VPLSとは対照的に、EVPNではコアでのコントロールプレーンベースのMAC学習が有効になります。EVPNでは、EVPNインスタンスに参加するPEは、マルチプロトコル(MP)-BGPプロトコルを使用して、コントロールプレーンでカスタムMACルートを学習します。コントロールプレーンMAC学習は、EVPNがVPLSの欠点に対処できるようにする多くの利点を提供します。これには、フロー単位のロードバランシングを使用したマルチホームのサポートが含まれます。

SR L2 EVPNは、Nexus 9300 FX2シリーズプラットフォームでサポートされるNXOS 9.3(1)で使用可能な新機能です。

SR MPLSでのL2 EVPNの制限

- SR L2 EVPNフラッディングは、入力レプリケーションメカニズムに基づいています
- BUMトラフィックにEVPNタイプ3ルートを使用する
- MPLSコアはマルチキャストをサポートしない
- Address Resolution Protocol(ARP)抑制はサポートされていません
- VPCでの整合性チェックはサポートされていません
- 同じL2 EVPNインスタンス(EVI)とL3 EVIと一緒に設定することはできません

設定

ネットワーク図

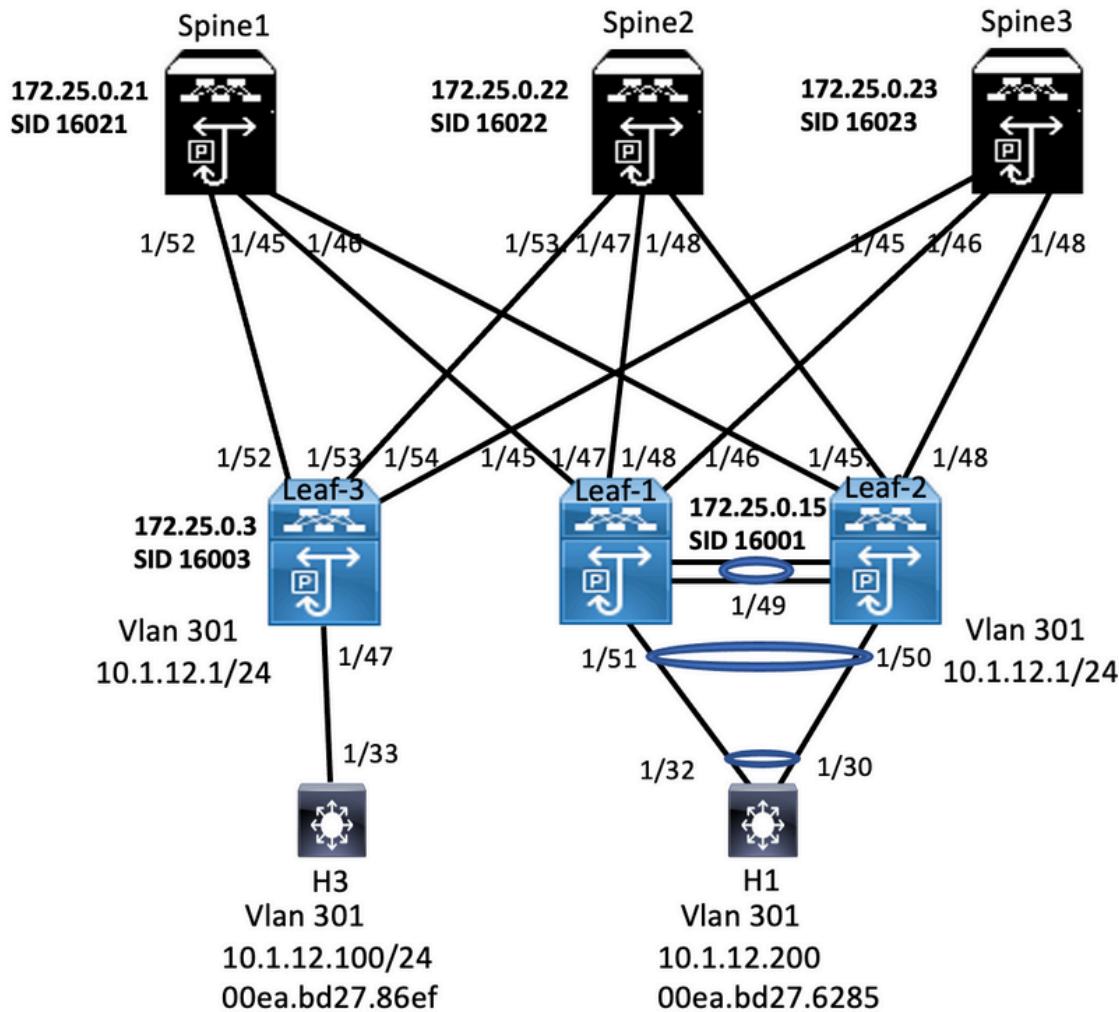

ハイレベル設定

1. 機能のインストール
2. IPアドレスの設定 - アンダーレイ
3. IGPの設定 : OSPF
4. MP - BGPの設定
5. VLANおよびEVPNオーバーレイの設定
6. ホストとリーフ間のe-BGPの設定
7. リーフ1および2でのVPCの設定

Enable Feature, Label-Range, Route-map, Label-Index	Spine1 Interface Configuration	BGP/EVPN Configuration
<pre>install feature-set mpls allow feature-set mpls feature-set mpls feature bgp feature mpls segment-routing feature mpls evpn feature interface-vlan feature mpls oam feature mpls segment-routing traffic-engineering segment-routing mpls global-block 16000 24000 connected-prefix-sid-map address-family ipv4 172.25.0.21/32 absolute 16021 ip prefix-list NH-RESTRICT seq 5 permit 0.0.0.0/0 ip prefix-list node-sid-loopback seq 5 permit 172.25.0.21/32 route-map NH-RESTRICT deny 10 match ip address prefix-list NH-RESTRICT route-map NH-RESTRICT permit 20 route-map NH_UNCHG permit 10 set ip next-hop unchanged</pre>	<pre>interface Ethernet1/45 description connected to Leaf1 - 1/45 - 192.168.1.9 mtu 9216 logging event port link-status no ip redirects ip address 192.168.1.10/30 ip arp timeout 14400 mpls ip forwarding interface Ethernet1/46 description connected to Leaf2- 1/46 - 192.168.2.9 mtu 9216 logging event port link-status no ip redirects ip address 192.168.2.10/30 ip arp timeout 14400 mpls ip forwarding interface Ethernet1/52 description connected to Leaf3 - 1/52 - 192.168.3.9 mtu 9216 logging event port link-status no ip redirects ip address 192.168.3.10/30 ip arp timeout 14400 mpls ip forwarding interface loopback0 ip address 172.25.0.21/32 icam monitor scale</pre>	<pre>router bgp 64087 router-id 172.25.0.21 bestpath as-path multipath-relax bestpath med missing-as-worst log-neighbor-changes nexthop suppress-default-resolution address-family ipv4 unicast network 172.25.0.21/32 maximum-paths 4 nexthop route-map NH-RESTRICT allocate-label route-map node-sid-label address-family ipv4 labeled-unicast prefix-priority high address-family l2vpn evpn retain route-target all neighbor 192.168.1.9 inherit peer EBG-ACCESS neighbor 192.168.2.9 inherit peer EBG-ACCESS neighbor 192.168.3.9 inherit peer EBG-ACCESS template peer EBG-ACCESS remote-as 65534 description EBG-PEERING-to-ACCESS address-family ipv4 unicast disable-peer-as-check send-community send-community extended default-originate no advertise local-labeled-route soft-reconfiguration inbound address-family ipv4 labeled-unicast disable-peer-as-check send-community send-community extended soft-reconfiguration inbound address-family l2vpn evpn disable-peer-as-check send-community send-community extended route-map NH_UNCHG out encapsulation mpls</pre>

Enable Feature, Label-Range, Route-map, Label-Index	Spine2	Interface Configuration	BGP/EVPN Configuration
install feature-set mpls allow feature-set mpls feature-set mpls feature bgp feature mpls segment-routing feature mpls evpn feature interface-vlan feature mpls oam feature mpls segment-routing traffic-engineering segment-routing mpls global-block 16000 24000 connected-prefix-sid-map address-family ipv4 172.25.0.22/32 absolute 16022 ip prefix-list NH-RESTRICT seq 5 permit 0.0.0.0/0 ip prefix-list node-sid-loopback seq 5 permit 172.25.0.22/32 route-map NH-RESTRICT deny 10 match ip address prefix-list NH-RESTRICT route-map NH-RESTRICT permit 20 route-map NH_UNCHG permit 10 set ip next-hop unchanged	Ethernet1/47 description connected to Leaf1 - 1/47 - 192.168.1.13 mtu 9216 logging event port link-status no ip redirects ip address 192.168.1.14/30 ip arp timeout 14400 mpls ip forwarding interface Ethernet1/48 description connected to Leaf2 - 1/45 - 192.168.2.13 mtu 9216 logging event port link-status no ip redirects ip address 192.168.2.14/30 ip arp timeout 14400 mpls ip forwarding interface Ethernet1/53 description connected to Leaf3 - 1/53 - 192.168.3.13 mtu 9216 logging event port link-status no ip redirects ip address 192.168.3.14/30 ip arp timeout 14400 mpls ip forwarding interface loopback0 ip address 172.25.0.22/32 icam monitor scale	router bgp 64087 router-id 172.25.0.22 bestpath as-path multipath-relax bestpath med missing-as-worst log-neighbor-changes nexthop suppress-default-resolution address-family ipv4 unicast network 172.25.0.22/32 maximum-paths 4 nexthop route-map NH-RESTRICT allocate-label route-map node-sid-label address-family ipv4 labeled-unicast prefix-priority high address-family I2vpn evpn retain route-target all neighbor 192.168.1.13 inherit peer EBG-ACCESS neighbor 192.168.2.13 inherit peer EBG-ACCESS neighbor 192.168.3.13 inherit peer EBG-ACCESS	template peer EBG-ACCESS remote-as 65534 description EBG-PEERING-to-ACCESS address-family ipv4 unicast disable-peer-as-check send-community send-community extended default-originate no advertise local-labeled-route soft-reconfiguration inbound address-family ipv4 labeled-unicast disable-peer-as-check send-community send-community extended soft-reconfiguration inbound address-family I2vpn evpn disable-peer-as-check send-community send-community extended route-map NH_UNCHG out encapsulation mpls

Enable Feature, Label-Range, Route-map, Label-Index	Leaf-1	Interface Configuration	BGP/EVPN Configuration
install feature-set mpls feature-set mpls nv overlay evpn feature bgp feature mpls segment-routing feature mpls evpn feature interface-vlan feature lisp feature vpc feature mpls oam feature nv overlay fabric forwarding anycast-gateway-mac 0000.0000.1111 vlan 1,301-310 segment-routing mpls global-block 16000 24000 connected-prefix-sid-map address-family ipv4 172.25.0.15/32 absolute 16001 vlan 301 evl auto vrf context VPN-A evl 30001 vrf context VPN-B rd auto address-family ipv4 unicast route-target import 302:302 route-target import 302:302 evpn route-target export 302:302 route-target export 302:302 evpn ip prefix-list node-sid-loopback seq 10 permit 172.25.0.15/32 ip as-path access-list LOCALLY-ORIGINATE seq 1 permit *65534* ip as-path access-list LOCALLY-ORIGINATE seq 2 permit **5* route-map NODE-SID-MED permit 10 match ip address prefix-list node-sid-loopback set metric 100 route-map NODE-SID-MED permit 20 route-map SET_NH permit 5 match community MATCH-65534-65534 set ip next-hop unchanged route-map SET_NH permit 10 match as-path LOCALLY-ORIGINATE set ip next-hop 172.25.0.15	vpc domain 21 peer-switch peer-keepalive destination 10.88.238.243 source 10.88.238.242 peer-gateway ip arp synchronize interface Ethernet1/49 switchport switchport mode trunk switchport trunk allowed vlan 301-310 channel-group 10 mode active interface Ethernet1/51 switchport switchport mode trunk switchport trunk allowed vlan 301-310 channel-group 30 mode active interface port-channel10 switchport switchport mode trunk switchport trunk allowed vlan 301-310 spanning-tree port type network vpc peer-link interface port-channel30 switchport mode trunk switchport trunk allowed vlan 301-310 vpc 30	interface Ethernet1/45 description connected to spine1 - 1/45 - 192.168.1.10 mtu 9216 logging event port link-status no ip redirects ip address 192.168.1.9/30 ip arp timeout 14400 mpls ip forwarding no shutdown interface Ethernet1/47 description connected to spine2 - 1/47 - 192.168.1.14 mtu 9216 logging event port link-status no ip redirects ip address 192.168.1.13/30 ip arp timeout 14400 mpls ip forwarding interface Vlan301 no shutdown vrf member VPN-A no ip redirects ip address 10.1.12.1/24 ip directed-broadcast ip-dir-bcast no ipv6 redirects ip arp timeout 720 fabric forwarding mode anycast-gateway	router bgp 65534 router-id 172.25.0.1 disable-policy-batching bestpath as-path multipath-relax bestpath med missing-as-worst log-neighbor-changes event-history detail size large nexthop suppress-default-resolution address-family ipv4 unicast network 172.25.0.1/32 network 172.25.0.15/32 network 172.25.0.201/32 maximum-paths 4 maximum-paths ibgp 4 allocate-label route-map node-sid-label address-family ipv4 labeled-unicast prefix-priority high address-family I2vpn evpn neighbor 192.168.1.10 inherit peer EBG-SPINE neighbor 192.168.1.14 inherit peer EBG-SPINE vrf VPN-A bestpath as-path multipath-relax allocate-index 2001 address-family ipv4 unicast network 10.1.12.0/24 advertise I2vpn evpn maximum-paths 4 vrf VPN-B bestpath as-path multipath-relax allocate-index 2002 address-family ipv4 unicast network 10.1.13.0/24 advertise I2vpn evpn maximum-paths 4 evpn evl 1000 encapsulation mpls source-interface loopback0

Enable Feature, Label-Range, Route-map, Label-Index	Leaf-2	Interface Configuration	BGP/EVPN Configuration
install feature-set mpls allow feature-set mpls feature-set mpls nv overlay evpn feature bgp feature mpls segment-routing feature mpls evpn feature interface-vlan feature lisp feature vpc feature mpls oam feature nv overlay forwarding anycast-gateway-mac 0000.0000.1111 vlan 1,301-310 segment-routing mpls global-block 16000 24000 connected-prefix-sid-map address-family ipv4 172.25.0.15/32 absolute 16001 vlan 301 evl auto ip prefix-list node-sid-loopback seq 10 permit 172.25.0.15/32 ip as-path access-list LOCALLY-ORIGINATE seq 1 permit *65534* ip as-path access-list LOCALLY-ORIGINATE seq 2 permit **5* route-map NODE-SID-MED permit 10 match ip address prefix-list node-sid-loopback set metric 100 route-map NODE-SID-MED permit 20 route-map SET_NH permit 5 match community MATCH-65534-65534 set ip next-hop unchanged route-map SET_NH permit 10 match as-path LOCALLY-ORIGINATE set ip next-hop 172.25.0.15 vrf context VPN-A evl 30001 vrf context VPN-B rd auto address-family ipv4 unicast route-target import 302:302 route-target import 302:302 evpn route-target export 302:302 route-target export 302:302 evpn	vpc domain 21 peer-switch peer-keepalive destination 10.88.238.242 source 10.88.238.243 peer-gateway ip arp synchronize port-channel10 switchport switchport mode trunk switchport trunk allowed vlan 301-310 spanning-tree port type network vpc peer-link interface port-channel30 switchport switchport mode trunk switchport trunk allowed vlan 301-310 vpc 30 interface Ethernet1/49 switchport switchport mode trunk switchport trunk allowed vlan 301-310 channel-group 10 mode active interface Ethernet1/50 switchport switchport mode trunk switchport trunk allowed vlan 301-310 channel-group 30 mode active	interface loopback0 ip address 172.25.0.1/32 ip address 172.25.0.15/32 secondary interface interface loopback1 ip address 172.25.0.201/32 icam monitor scale description connected to spine2 - 1/48 - 192.168.2.14 mtu 9216 logging event port link-status no ip redirects ip address 192.168.2.13/30 ip arp timeout 14400 mpls ip forwarding no shutdown interface Ethernet1/46 description connected to Spine1 - 1/46 - 192.168.2.10 mtu 9216 logging event port link-status no ip redirects ip address 192.168.2.9/30 ip arp timeout 14400 mpls ip forwarding no shutdown interface Vlan1 no ip redirects no ipv6 redirects interface Vlan301 no shutdown vrf member VPN-A no ip redirects ip address 10.1.12.1/24 ip directed-broadcast ip-dir-bcast no ipv6 redirects ip arp timeout 720 fabric forwarding mode anycast-gateway	router bgp 65534 template peer EBG-SPINE remote-as 64087 description EBG-PEERING-to-AGG address-family ipv4 unicast allows-in 1 send-community send-community extended route-map NODE-SID-MED out no advertise local-labeled-route soft-reconfiguration inbound address-family ipv4 labeled-unicast allows-in 1 send-community send-community extended route-map NODE-SID-MED out soft-reconfiguration inbound always address-family I2vpn evpn allows-in 1 send-community send-community extended filter-list LOCALLY-ORIGINATE out route-map SET_NH out encapsulation mpls vrf VPN-A bestpath as-path multipath-relax allocate-index 2001 address-family ipv4 unicast network 10.1.12.0/24 advertise I2vpn evpn maximum-paths 4 vrf VPN-B bestpath as-path multipath-relax allocate-index 2002 address-family ipv4 unicast network 10.2.13.0/24 advertise I2vpn evpn maximum-paths 4 evpn evl 1000 encapsulation mpls source-interface loopback0

Enable Feature, Label-Range, Route-map, Label-Index	Leaf-3 Interface Configuration	BGP/EVPN Configuration	
<pre> install feature-set mpls feature-set mpls nv overlay evpn feature bgp feature mpls segment-routing feature mpls evpn feature mpls oam feature nv overlay fabric forwarding anycast-gateway-mac 0000.0000.1111 vlan 1,301 segment-routing mpls global-block 16000 24000 connected-prefix-sid-map address-family ipv4 172.25.0.3/32 absolute 16003 vlan 301 evi auto ip prefix-list node-sid-loopback seq 10 permit 172.25.0.3/32 ip as-path access-list LOCALLY-ORIGINATE seq 1 permit **65534* ip as-path access-list LOCALLY-ORIGINATE seq 2 permit **5* route-map NODE-SID-MED permit 10 match ip address prefix-list node-sid-loopback set metric 100 route-map NODE-SID-MED permit 20 route-map SET_NH permit 5 match community MATCH-65534-65534 set ip next-hop unchanged route-map SET_NH permit 10 match as-path LOCALLY-ORIGINATE set ip next-hop 172.25.0.3 vrf context VPN-A evi 30001 vrf context VPN-B rd auto address-family ipv4 unicast route-target import 302:302 route-target import 302:302 evpn route-target export 302:302 route-target export 302:302 evpn </pre>	<pre> ip access-group deny-to-core_ra in vrf member VPN-A no ip redirects ip address 10.1.12.1/24 fabric forwarding mode anycast-gateway interface Vlan302 ip access-group deny-to-core_ra in vrf member VPN-B no ip redirects ip address 10.3.13.1/24 ip directed-broadcast ip-dir-bcast ip arp timeout 720 Ethernet1/47 switchport switchport mode trunk switchport trunk allowed vlan 301-310 interface Ethernet1/53 description connected to Spine1 - 1/52 - 192.168.3.10 mtu 9216 logging event port link-status no ip redirects ip address 192.168.3.9/30 ip arp timeout 14400 mpls ip forwarding interface Ethernet1/53 description connected to Spine2 - 1/53 - 20.3.1.14 mtu 9216 logging event port link-status no ip redirects ip address 192.168.3.13/30 ip arp timeout 14400 mpls ip forwarding no shutdown interface loopback0 ip address 172.25.0.3/32 icam monitor scale </pre>	<pre> router bgp 65534 router-id 172.25.0.3 disable-policy-batching bestpath as-path multipath-relax bestpath med missing-as-worst log-neighbor-changes event-history detail size large nexthop suppress-default-resolution address-family ipv4 unicast network 172.25.0.3/32 maximum-paths 4 interface maximum-paths ibgp 4 allocate-label route-map node-sid-label address-family ipv4 labeled-unicast prefix-priority high address-family l2vpn evpn neighbor 192.168.3.10 inherit peer EBGP-SPINE neighbor 192.168.3.14 inherit peer EBGP-SPINE vrf VPN-A bestpath as-path multipath-relax allocate-index 2001 address-family ipv4 unicast advertise l2vpn evpn maximum-paths 4 evpn evi 1000 encapsulation mpls </pre>	<pre> template peer EBGP-SPINE remote-as 64087 description EBGP-PEERING-to-AGG address-family ipv4 unicast allows-in 1 send-community send-community extended route-map NODE-SID-MED out no advertise local-labeled-route soft-reconfiguration inbound address-family ipv4 labeled-unicast allows-in 1 send-community send-community extended route-map NODE-SID-MED out soft-reconfiguration inbound always address-family l2vpn evpn allows-in 1 send-community send-community extended route-map SET_NH out encapsulation mpls </pre>

Host-1 (H1) Configuration	Host-3 (H3) Configuration
---------------------------	---------------------------

```

interface Ethernet1/30
switchport
switchport mode trunk
switchport trunk allowed vlan 301-310
channel-group 30 mode active
no shutdown

interface Vlan301
no shutdown
no ip redirects
ip address 10.1.12.100/24

interface Ethernet1/32
switchport
switchport mode trunk
switchport trunk allowed vlan 301-310
channel-group 30 mode active
no shutdown

interface port-channel30
switchport
switchport mode trunk
switchport trunk allowed vlan 301-310

```

```

interface Vlan301
no shutdown
no ip redirects
ip address 10.1.12.200/24

interface Ethernet1/33
switchport
switchport mode trunk
switchport trunk allowed vlan 301-310
no shutdown

```

確認

このセクションでは、設定が正常に機能していることを確認します。

```
ping 10.1.12.200
PING 10.1.12.200 [10.1.12.200]: 56 data bytes
64 bytes from 10.1.12.200: icmp_seq=0 ttl=254 time=1.34 ms
64 bytes from 10.1.12.200: icmp_seq=1 ttl=254 time=0.687 ms
64 bytes from 10.1.12.200: icmp_seq=2 ttl=254 time=0.658 ms
64 bytes from 10.1.12.200: icmp_seq=3 ttl=254 time=0.636 ms
64 bytes from 10.1.12.200: icmp_seq=4 ttl=254 time=0.699 ms
--- 10.1.12.200 ping statistics ---
5 packets transmitted, 5 packets received, 0.00% packet loss
round-trip min/avg/max = 0.636/1.14 ms

H3# show ip int br
IP Interface Status for VRF "default"(1)
Interface IP Address Interface Status
Vlan301 10.1.12.100 protocol-up/link-up/admin-up

H3# show mac address-table
Legend:
* - primary entry, G - Gateway MAC, (R) - Routed MAC, O - Overlay MAC
age - seconds since last seen, - primary entry using vPC Peer-Link,
(T) - True, (F) - False, C - ControlPlane MAC, ~ - vsan
VLAN MAC Address Type age Secure NTFY Ports
* 301 0000.0000.1111 dynamic O F F Po30
* 301 00ea.bd27.86ef dynamic O F F Po30
G - 00ea.bd27.6285 static - F F sup-eth1(R)
G 301 00ea.bd27.6285 static - F F sup-eth1(R)
```

```
H3# show ip interface brief
Interface IP Address Interface Status
Vlan301 10.1.12.200 protocol-up/link-up/admin-up
H3# ping 10.1.12.100
PING 10.1.12.100 [10.1.12.100]: 56 data bytes
64 bytes from 10.1.12.100: icmp_seq=0 ttl=254 time=1.211 ms
64 bytes from 10.1.12.100: icmp_seq=1 ttl=254 time=0.694 ms
64 bytes from 10.1.12.100: icmp_seq=2 ttl=254 time=0.68 ms
64 bytes from 10.1.12.100: icmp_seq=3 ttl=254 time=0.673 ms
64 bytes from 10.1.12.100: icmp_seq=4 ttl=254 time=0.624 ms
--- 10.1.12.100 ping statistics ---
5 packets transmitted, 5 packets received, 0.00% packet loss
round-trip min/avg/max = 0.624/0.776/1.211 ms
H3# show int vlan 301
Vlan301 is up, line protocol is up, autostate-enabled
Hardware is EtherSVL, address is 00ea.bd27.86ef
H3# show mac address-table
Legend:
* - primary entry, G - Gateway MAC, (R) - Routed MAC, O - Overlay MAC
age - seconds since last seen, - primary entry using vPC Peer-Link,
VLAN MAC Address Type age Secure NTFY Ports
* 301 0000.0000.1111 dynamic O F F Eth1/33
* 301 00ea.bd27.6285 dynamic O F F Eth1/33
G - 00ea.bd27.86ef static - F F sup-eth1(R)
G 301 00ea.bd27.86ef static - F F sup-eth1(R)
```

```
spine-1# show bgp l2vpn evpn
BGP routing table information for VRF default, address family L2VPN Evpn
BGP table version is 188, Local Router ID is 172.25.0.21
Status: s-suppressed, x-deleted, S-stale, d-dampened, h-history, *valid, >best
Path type: i-internal, e-external, c-confed, i-local, a-aggregate, r-redist, i-
njected
Origin codes: i - IGP, e - EGP, ? - incomplete, | - multipath, & - backup, 2 - Network
Next Hop Metric LocPrf Weight Path
Route Distinguisher: 172.25.0.15
*e[5] [0] [0] [24] [12.1.12.0]/224
172.25.0.15 4294967295 0 65534 i
Route Distinguisher: 172.25.0.137164
*e[2] [0] [0] [48] [00ea.bd27.6285] [0] [0.0.0.0]/216
172.25.0.15 4294967295 0 65534 i
*e[2] [0] [0] [48] [00ea.bd27.6285] [32] [10.1.12.100]/272
172.25.0.15 4294967295 0 65534 i
*e[3] [0] [32] [172.25.0.3]/88
172.25.0.15 4294967295 0 65534 i
Route Distinguisher: 172.25.0.237164
*e[2] [0] [0] [48] [00ea.bd27.6285] [0] [0.0.0.0]/216
172.25.0.15 4294967295 0 65534 i
*e[2] [0] [0] [48] [00ea.bd27.6285] [32] [10.1.12.100]/272
172.25.0.3 4294967295 0 65534 i
*e[3] [0] [32] [172.25.0.3]/88
172.25.0.3 4294967295 0 65534 i
Route Distinguisher: 172.25.0.337164
*e[2] [0] [0] [48] [00ea.bd27.86ef] [0] [0.0.0.0]/216
172.25.0.3 4294967295 0 65534 i
*e[2] [0] [0] [48] [00ea.bd27.86ef] [32] [10.1.12.200]/272
172.25.0.3 4294967295 0 65534 i
*e[3] [0] [32] [172.25.0.3]/88
172.25.0.3 4294967295 0 65534 i
```

```
BGP routing table information for VRF default, address family L2VPN
Evpn
BGP table version is 188, Local Router ID is 172.25.0.15
Status: s-suppressed, x-deleted, S-stale, d-dampened, h-history, *valid,
>best
Path type: i-internal, e-external, c-confed, i-local, a-aggregate, r-redist, i-
njected
Origin codes: i - IGP, e - EGP, ? - incomplete, | - multipath, & - backup, 2 -
Network Next Hop Metric LocPrf Weight Path
Route Distinguisher: 172.25.0.15
*e[5] [0] [0] [24] [12.1.12.0]/224
172.25.0.15 4294967295 0 65534 i
Route Distinguisher: 172.25.0.137164
*e[2] [0] [0] [48] [00ea.bd27.6285] [0] [0.0.0.0]/216
172.25.0.15 4294967295 0 65534 i
*e[2] [0] [0] [48] [00ea.bd27.6285] [32] [10.1.12.100]/272
172.25.0.15 4294967295 0 65534 i
Route Distinguisher: 172.25.0.237164
*e[2] [0] [0] [48] [00ea.bd27.6285] [0] [0.0.0.0]/216
172.25.0.15 4294967295 0 65534 i
*e[2] [0] [0] [48] [00ea.bd27.6285] [32] [10.1.12.100]/272
172.25.0.3 4294967295 0 65534 i
Route Distinguisher: 172.25.0.337164
*e[2] [0] [0] [48] [00ea.bd27.86ef] [0] [0.0.0.0]/216
172.25.0.3 4294967295 0 65534 i
*e[2] [0] [0] [48] [00ea.bd27.86ef] [32] [10.1.12.200]/272
172.25.0.3 4294967295 0 65534 i
*e[3] [0] [32] [172.25.0.3]/88
172.25.0.3 4294967295 0 65534 i
```

```
spine-1# show ip int br
IP Interface Status for VRF "default"(1)
Interface IP Address Interface Status
Lo0 172.25.0.21 protocol-up/link-up/admin-up
Eth1/45 192.168.1.10 protocol-up/link-up/admin-up
Eth1/46 192.168.2.10 protocol-up/link-up/admin-up
Eth1/52 192.168.3.10 protocol-up/link-up/admin-up
vswan-1#
```

```
spine2# show ip int br
IP Interface Status for VRF "default"(1)
Interface IP Address Interface Status
Lo0 172.25.0.22 protocol-up/link-up/admin-up
Eth1/47 192.168.1.14 protocol-up/link-up/admin-up
Eth1/48 192.168.2.14 protocol-up/link-up/admin-up
Eth1/53 192.168.3.14 protocol-up/link-up/admin-up
spine2#
```

トラブルシューティング

ここでは、設定のトラブルシューティングに使用できる情報を示します。

```
Leaf1# show l2
l2 l2protocol l2vib l2route
Leaf1# show nve evl
EVI Vlan Label Oper State EVI State
301 301 964878 UP evi-add-complete
Leaf1# show bgp l2vpn evpn
Network Next Hop Metric LocPrf Weight Path
Route Distinguisher: 172.25.0.137164 (L2VNI 301)
*e[2] [0] [0] [48] [00ea.bd27.6285] [0] [0.0.0.0]/216
172.25.0.15 4294967295 0 64087 655
*e[2] [0] [0] [48] [00ea.bd27.86ef] [0] [0.0.0.0]/216
172.25.0.3 4294967295 0 64087 655
34 i
*e[2] [0] [0] [48] [00ea.bd27.6285] [32] [10.1.12.100]/272
172.25.0.15 100 32768 i
*e[2] [0] [0] [48] [00ea.bd27.86ef] [32] [10.1.12.200]/272
172.25.0.3 4294967295 0 64087 655
34 i
*e[3] [0] [32] [172.25.0.3]/88
172.25.0.3 4294967295 0 64087 655
34 i
*e[3] [0] [32] [172.25.0.15]/88
172.25.0.15 100 32768 i
Route Distinguisher: 172.25.0.337164
*e[2] [0] [0] [48] [00ea.bd27.86ef] [0] [0.0.0.0]/216
172.25.0.3 4294967295 0 64087 655
34 i
*e[2] [0] [0] [48] [00ea.bd27.86ef] [32] [10.1.12.100]/272
172.25.0.3 4294967295 0 64087 655
34 i
*e[2] [0] [0] [48] [00ea.bd27.86ef] [32] [10.1.12.200]/272
172.25.0.3 4294967295 0 64087 655
34 i
*e[3] [0] [32] [172.25.0.3]/88
172.25.0.3 4294967295 0 64087 655
34 i
*e[3] [0] [32] [172.25.0.15]/88
172.25.0.15 100 32768 i
Route Distinguisher: 172.25.0.15
*e[2] [0] [0] [48] [00ea.bd27.86ef] [32] [10.1.12.200]/272
172.25.0.3 4294967295 0 64087 655
34 i
*e[3] [0] [32] [172.25.0.3]/88
100 32768 i
```

```
Leaf2# show nve evl
EVI Vlan Label Oper State EVI State
301 301 964878 UP evi-add-complete
Leaf2# show bgp l2vpn evpn
Network Next Hop Metric LocPrf Weight Path
Route Distinguisher: 172.25.0.237164 (L2VNI 301)
*e[2] [0] [0] [48] [00ea.bd27.6285] [0] [0.0.0.0]/216
172.25.0.15 100 32768 i
*e[2] [0] [0] [48] [00ea.bd27.86ef] [0] [0.0.0.0]/216
172.25.0.3 4294967295 0 64087 655
34 i
*e[2] [0] [0] [48] [00ea.bd27.6285] [32] [10.1.12.100]/272
172.25.0.15 100 32768 i
*e[2] [0] [0] [48] [00ea.bd27.86ef] [32] [10.1.12.200]/272
172.25.0.3 4294967295 0 64087 655
34 i
*e[3] [0] [32] [172.25.0.3]/88
172.25.0.3 4294967295 0 64087 655
34 i
*e[3] [0] [32] [172.25.0.15]/88
172.25.0.15 100 32768 i
Route Distinguisher: 172.25.0.337164
*e[2] [0] [0] [48] [00ea.bd27.86ef] [0] [0.0.0.0]/216
172.25.0.3 4294967295 0 64087 655
34 i
*e[2] [0] [0] [48] [00ea.bd27.86ef] [32] [10.1.12.100]/272
172.25.0.3 4294967295 0 64087 655
34 i
*e[2] [0] [0] [48] [00ea.bd27.86ef] [32] [10.1.12.200]/272
172.25.0.3 4294967295 0 64087 655
34 i
*e[3] [0] [32] [172.25.0.3]/88
172.25.0.3 4294967295 0 64087 655
34 i
*e[3] [0] [32] [172.25.0.15]/88
172.25.0.15 100 32768 i
Route Distinguisher: 172.25.0.237164
*e[2] [0] [0] [48] [00ea.bd27.6285] [0] [0.0.0.0]/216
172.25.0.15 4294967295 0 64087 655
34 i
*e[2] [0] [0] [48] [00ea.bd27.6285] [32] [10.1.12.100]/272
172.25.0.15 4294967295 0 64087 655
34 i
*e[3] [0] [32] [172.25.0.3]/88
172.25.0.15 4294967295 0 64087 655
34 i
*e[3] [0] [32] [172.25.0.15]/88
172.25.0.15 4294967295 0 64087 655
34 i
Route Distinguisher: 172.25.0.337164 (L2VNI 301)
*e[2] [0] [0] [48] [00ea.bd27.6285] [0] [0.0.0.0]/216
172.25.0.15 4294967295 0 64087 655
34 i
*e[2] [0] [0] [48] [00ea.bd27.6285] [32] [10.1.12.100]/272
172.25.0.15 4294967295 0 64087 655
34 i
*e[3] [0] [32] [172.25.0.3]/88
172.25.0.15 4294967295 0 64087 655
34 i
*e[3] [0] [32] [172.25.0.15]/88
172.25.0.15 100 32768 i
Route Distinguisher: 172.25.0.15
*e[2] [0] [0] [48] [00ea.bd27.86ef] [0] [0.0.0.0]/216
172.25.0.3 4294967295 0 64087 655
34 i
*e[2] [0] [0] [48] [00ea.bd27.86ef] [32] [10.1.12.200]/272
172.25.0.3 4294967295 0 64087 655
34 i
*e[3] [0] [32] [172.25.0.3]/88
100 32768 i
```

```
Leaf3# show mac address-table
Legend:
* - primary entry, G - Gateway MAC, (R) - Routed MAC, O - Overlay MAC
age - seconds since last seen, - primary entry using vPC Peer-Link,
(T) - True, (F) - False, C - ControlPlane MAC, ~ - vsan,
(NA) - Not Applicable
VLAN MAC Address Type age Secure NTFY Ports
+ 301 00ea.bd27.6285 dynamic NA F F Po30
C 301 00ea.bd27.86ef dynamic NA F F sr-peer(172.25.0.3)
G - 0000.0000.1111 static - F F sup-eth1(R)
G 301 c014.fea3.bc87 static - F F vPC Peer-Link(R)
G - c014.fea3.ca07 static - F F sup-eth1(R)
G 301 c014.fea3.ca07 static - F F sup-eth1(R)
Leaf1#
```

```
Leaf3# show mac address-table
Legend:
* - primary entry, G - Gateway MAC, (R) - Routed MAC, O - Overlay MAC
age - seconds since last seen, - primary entry using vPC Peer-Link,
(T) - True, (F) - False, C - ControlPlane MAC, ~ - vsan,
(NA) - Not Applicable
VLAN MAC Address Type age Secure NTFY Ports
C 301 00ea.bd27.6285 dynamic NA F F sr-peer(172.25.0.15)
* 301 00ea.bd27.86ef dynamic NA F F Eth1/47
G - 0000.0000.1111 static - F F sup-eth1(R)
G - c014.fea3.cadf static - F F sup-eth1(R)
G 301 c014.fea3.cadf static - F F sup-eth1(R)
Leaf3#
```

```
Leaf2# show mac address-table
Legend:
* - primary entry, G - Gateway MAC, (R) - Routed MAC, O - Overlay MAC
age - seconds since last seen, - primary entry using vPC Peer-Link,
(T) - True, (F) - False, C - ControlPlane MAC, ~ - vsan,
(NA) - Not Applicable
VLAN MAC Address Type age Secure NTFY Ports
+ 301 00ea.bd27.6285 dynamic NA F F Po30
C 301 00ea.bd27.86ef dynamic NA F F sr-peer(172.25.0.3)
G - 0000.0000.1111 static - F F sup-eth1(R)
G - c014.fea3.bc87 static - F F sup-eth1(R)
G 301 c014.fea3.bc87 static - F F sup-eth1(R)
G 301 c014.fea3.ca07 static - F F vPC Peer-Link(R)
Leaf2#
```

翻訳について

シスコは世界中のユーザにそれぞれの言語でサポート コンテンツを提供するために、機械と人による翻訳を組み合わせて、本ドキュメントを翻訳しています。ただし、最高度の機械翻訳であっても、専門家による翻訳のような正確性は確保されません。シスコは、これら翻訳の正確性について法的責任を負いません。原典である英語版（リンクからアクセス可能）もあわせて参照することを推奨します。