



AP Mode Configuration

- [Configuring Indoor Deployment for -E Domain, on page 1](#)
- [802.11ax 1600ns and 3200ns Guard Interval Support, on page 4](#)
- [GNSS Support, on page 5](#)
- [RAP Ethernet Daisy Chain, on page 6](#)

Configuring Indoor Deployment for -E Domain

IW9167EH supports indoor deployment for -E domain.

By default, indoor deployment is disabled, and the 5G radio supports channels 100, 104, 108, 112, 116, 120, 124, 128, 132, 136, 140. After factory reset, indoor deployment configuration is reset to default, which is disabled.

You can check AP mode by using the **show ap name <ap-name> config general | section Indoor** command. In the command output, "Enabled" means AP is in indoor mode, and "Disabled" means AP is in outdoor mode, as shown in the following example.

```
#show ap name APFC58.9A15.C9A4 config general | inc Indoor
AP Indoor Mode                               : Disabled
```

Edit Radios 5 GHz Band ✕

Configure
Detail

General

AP Name: APFC58.9A15.C9A4

AP Mode: Local

Admin Status: ENABLED

Mesh Backhaul: Disabled

Mesh Designated Downlink: Disabled

Antenna Parameters

Antenna Type: External

Antenna Mode: Omni

Self-Identifying Antenna (SIA): Not Present

Radio Profile: [roaming-radio-profile](#)

Number of Antennas Selected: 1

Supported Antenna Modes: 1x1, 2x2, 4x4

Antenna Port Mapping: 4

Antenna Gain (in .5 dBi units):

Download [Core Dump](#) to bootflash

RF Channel Assignment

Current Channel: 100

Channel Width: 20 MHz

Assignment Method: Custom

Channel Number:

100

104

108

112

116

120

124

128

Tx Power Level Assignment:

Current Tx Power Level: 112

Assignment Method:

BSS Color

BSS Color Configuration: Global

BSS Color Global Admin Status: Disabled

BSS Color Radio Operational Status: Disabled

BSS Color Radio Admin Status: ENABLED

Current BSS Color:

To configure the AP to indoor mode, use the **ap name** *<ap-name>* **indoor** command from wireless LAN controller. This command triggers an AP rebooting. After AP registers to the wireless LAN controller after rebooting, you need to assign corresponding country code to the AP. When indoor deployment is enabled, 5G radio supports channels 36, 40, 44, 48, 52, 56, 60, 64, 100, 104, 108, 112, 116, 120, 124, 128, 132, 136, 140.



Note To disable indoor deployment, use the **ap name** *<ap-name>* **no indoor** command.

The screenshot shows the Cisco Catalyst 9800-L Wireless Controller configuration interface. On the left, a navigation sidebar includes Dashboard, Monitoring, Configuration, Administration, Licensing, and Troubleshooting. The main content area is titled 'Configuration > Wireless > Access Points'. Under 'All Access Points', a table lists several APs, with APFC58.9A15.C9A4 selected. The 'Edit AP' configuration window is open, showing the 'Advanced' tab. The 'Country Code*' dropdown is set to 'FR'. Other settings include 'Multiple Countries' (CN, FR, US), 'Statistics Timer' (180), 'CAPWAP MTU' (1485), 'AP Link Latency' (Disabled), 'AP PMK Propagation Capability' (Enabled), 'Global mDNS Gateway' (Disabled), 'mDNS' (Enabled), 'Services Learnt' (0), 'TCP Adjust MSS Option' (Enabled), 'AP TCP MSS Adjust' (Enabled), 'AP TCP MSS Size' (1250), 'AP IPv6 TCP MSS Adjust' (Enabled), 'AP IPv6 TCP MSS Size' (1250), and 'AP Retransmit Config Parameters'. The 'AP Image Management' section includes options for image predownload, swap, and crash data. The 'Hardware Reset' section includes options for performing a reset and clearing configurations.

Edit Radios 5 GHz Band

Configure Detail

General		RF Channel Assignment	
AP Name	APFC58.9A15.C9A4	Current Channel	36
AP Mode	Local	Channel Width	20 MHz
Admin Status	ENABLED <input checked="" type="checkbox"/>	Assignment Method	Custom
Mesh Backhaul	Disabled	Channel Number	36
Mesh Designated Downlink	Disabled	Tx Power Level Assignmer	40
Antenna Parameters		Current Tx Power Level	44
Antenna Type	External	Assignment Method	48
Antenna Mode	Omni	BSS Color	52
			56
			60
			64



Note Channel list extends from U-NII-2c to U-NII-1, U-NII-2a, U-NII-2c (channel 144 is excluded).

802.11ax 1600ns and 3200ns Guard Interval Support

802.11ac has two Guard Interval (GI) options – long GI (800ns) and short GI (400ns). 802.11ax introduces new guard interval options. It has three types of GI – 800ns, 1600ns, and 3200ns. Longer guard intervals provide improved performance in environments with multi-path and delay spread. It improves link reliability for longer-range outdoor deployments and helps to prevent inter-symbol interference in outdoor environments and therefore improve coverage and performance.

The following table compares 802.11ax to the previous two standards.

Table 1: 802.11ax Guard Interval Comparing With Previous Standards

Capabilities	802.11n	802.11ac	802.11ax
Physical Layer (PHY)	High Throughput (HT)	Very High Throughput (VHT)	High-Efficiency (HE)
Guard Interval	800/400 ns	800/400 ns	800/1600/3200 ns

Configuring 802.11ax Long Guard Interval

HE mode guard intervals should be configured in RF profiles.

Step 1 Enters global configuration mode.

```
Device#configure terminal
```

Example:

```
Device#conf t
Enter configuration commands, one per line. End with CNTL/Z.
```

Step 2 Configures RF profile and enters RF profile configuration mode

```
ap dot11 {24ghz|5ghz} rf-profile <profile-name>
```

Example:

```
Device(config)#ap dot11 24ghz rf-profile 24G-RF-profile
```

Step 3 Configures guard interval for the RF profile.

```
guard-interval {GUARD_INTERVAL_1600NS | GUARD_INTERVAL_3200NS | GUARD_INTERVAL_400NS
| GUARD_INTERVAL_800NS}
```

Example:

```
Device(config-rf-profile)#guard-interval GUARD_INTERVAL_1600NS
```

- GUARD_INTERVAL_1600NS: Set 1600 ns guard interval (only in HE mode)
- GUARD_INTERVAL_3200NS: Set 3200 ns guard interval (only in HE mode)
- GUARD_INTERVAL_400NS: Set 400 ns guard interval (HT VHT mode)
- GUARD_INTERVAL_800NS: Set 800 ns guard interval

Note Valid guard interval values are 800, 1600, and 3200 ns for HE mode. By default, GI is 800 ns.

Step 4 Exit global configuration mode.

end

Example:

Device(config)#**end**

Use the following command to verify the configuration on wireless controller:

```
#show ap rf-profile name Demo-24G-RF-profile detail | inc Guard
Guard Interval      : 1600ns
#show ap rf-profile name Demo-5G-RF-profile detail | inc Guard
Guard Interval      : 3200ns
```

Example

1. Define GI in RF profile

```
ap dot11 24ghz rf-profile Demo-24G-RF-profile
shutdown
guard-interval GUARD_INTERVAL_1600NS
no shutdown
ap dot11 5ghz rf-profile Demo-5G-RF-profile
shutdown
guard-interval GUARD_INTERVAL_3200NS
no shutdown
```

2. Associate RF profile to RF tag

```
wireless tag rf Demo-Guard-Interval-RF-tag
24ghz-rf-policy Demo-24G-RF-profile
5ghz-rf-policy Demo-5G-RF-profile
```

3. Associate RF tag to AP

```
ap fc58.9a15.c83c
rf-tag Demo-Guard-Interval-RF-tag
```

GNSS Support

From Cisco IOS XE Dublin 17.11.1, GNSS is supported on IW9167EH. The AP tracks GPS information for devices deployed in the outdoor environment and sends the GNSS information to the wireless controller.

Use the following command to display the GNSS information on the AP:

```
ap# show gnss info.
```

Use the following commands to display the GPS location of the AP:

```
controller# show ap geolocation summary
```

```
controller# show ap name <Cisco AP> geolocation detail
```

RAP Ethernet Daisy Chain

The RAP Ethernet Daisy Chain feature enhances the existing Ethernet bridging functionality. It forces the bridge AP to stick to the Ethernet link, and block the selecting of wireless link for uplink backhaul. Even the Ethernet link failure happens, the access point will never select a parent over wireless backhaul.

The following figure shows an example of RAP Ethernet Daisy Chain topology. Standalone DC power source is provided to each RAP.

Figure 1: RAP Ethernet Daisy Chain Topology

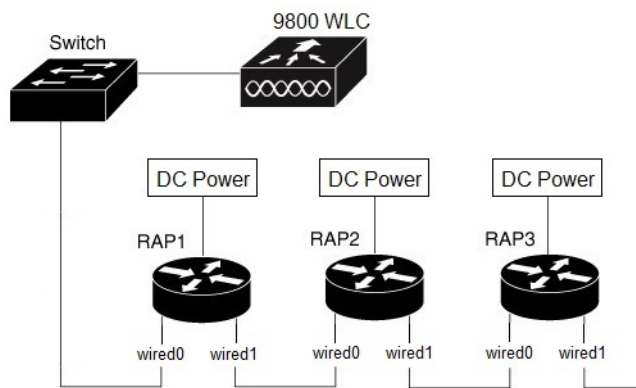

Table 2: Port Mapping

Panel Label	SW Interface
mGig POE-IN port	wired 0
SFP	wired 1



Note The supported SFP module for this feature is the 1000BASE-T rugged SFP (Cisco PID: GLC-T-RGD).

Follow these guidelines when you configure this feature:

- All APs in daisy chain is operating in mesh bridge mode or Flex+Bridge mode with Root AP role. The PoE-IN (wired0) and SFP (wired1) port can be used as uplink port and the PoE-IN (wired0) port has the higher priority than SFP (wired1).
- VLAN transparency should be disabled on all daisy-chained RAPs.
- To enable VLAN support on each root AP:
 - For bridge mode APs, use the **ap name name-of-rap mesh vlan-trunking [native] vlan-id** command to configure a trunk VLAN on the corresponding RAP.
 - For Flex+Bridge APs, you must configure the native VLAN ID under the corresponding flex profile.

The RAP Ethernet Daisy Chain feature is already supported on Cisco IOS XE Cupertino 17.9.3, while it has the following limitations:

- Primary ethernet port (mGig port) must be used as uplink. In this case, SFP port to SFP port connection is not supported, which impacts network throughput (no 2.5Gbps or 5Gbps copper SFP available when SFP connect to mGig port).
- Reuse an existing command **persistant-ssid** to enable the RAP Ethernet Daisy Chain feature, which is misleading.

In Cisco IOS XE Dublin 17.11.1, the RAP Ethernet Daisy Chain feature is enhanced to support the following functions:

- Wireless Spanning Tree Protocol (WSTP) hello is enabled to support auto root port detection, so that RAP can use any port as its uplink. See the following topology.

Figure 2: RAP Ethernet Daisy Chain With WSTP Topology

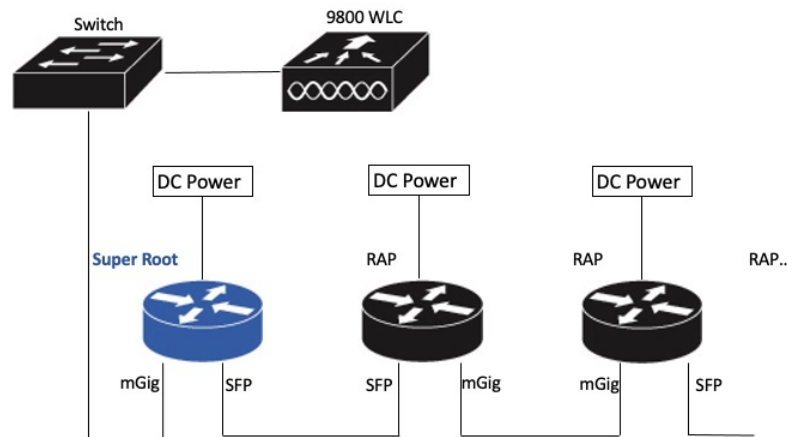

- A separate and dedicated command **rap-eth-daisychain** is introduced to enable the feature.

WSTP Overview

Wireless LAN spanning tree protocol (WSTP) organizes a Cisco mesh network into a loop-free spanning tree topology. It quickly configure a mesh network into a stable, loop-free, optimal spanning tree topology, where an optimal topology provides least-cost paths to the primary Ethernet LAN. WSTP Hello messages are used to build the WSTP topology.

The WSTP super root is a single RAP that is elected as the highest level “super” root for the entire WSTP spanning tree. The super root is directly attached to the primary LAN. The super root transmits zero-cost WSTP SR Hello messages on its Ethernet root port to advertise the primary LAN to RAPs.

Comparison with Previous Release

The following table compares the daisy chain features in current release and prior to 17.11:

	Prior to Release 17.11.1	Release 17.11.1
Topology	Fixed topology RAP must use its mGig port as uplink in daisy chain topology	Flexible topology RAP can use either mGig port or SFP port as uplink in daisy chain topology by enabling WSTP on AP
Feature enablement	Persistent-ssid in AP profile 1	rap-eth-daisychain in Mesh profile
Ring Topology	Not supported 2	Not supported

¹ **Persistent-ssid** is still supported in 17.11, so that daisy chain function will not be impacted after upgrading from previous release to 17.11 with old configuration. But **Persistent-ssid** is not recommended in 17.11, and the new **rap-eth-daisychain** command is recommended.

² Supported only on IW6300 access point, by enabling **daisychain-stp-redundancy**. For more information, see the [RAP Ethernet Daisy Chain Redundancy for STP Ring Topology](#) section in [Cisco Catalyst IW6300 Heavy Duty Series and 6300 Series Embedded Services Access Point Software Configuration Guide](#).

RAP Ethernet Daisy Chain Configuration

This section provides procedures for the RAP Ethernet daisy chain configuration.

Preconfiguring RAP Ethernet Daisy Chain Before Field Deployment

This section provides the preconfiguration that you should complete in lab before you set up in field deployment.

Step 1 Unpack, connect, and power on the AP.

Step 2 Join each AP to controller with mGig port. See the following figure for details.

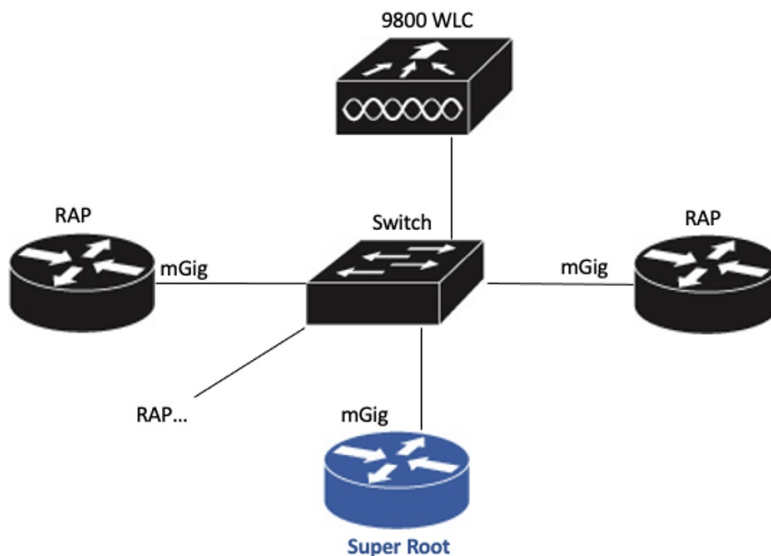

Step 3 Configure AP to bridge mode and configure AP role to Root AP.

For detailed configuration procedures, see https://www.cisco.com/c/en/us/td/docs/wireless/controller/9800/17-11/config-guide/b_wl_17_eleven_cg/m_mesh_ewlc.html#task_pnb_bwy_mlb.

Step 4 Configuring RAP Ethernet Daisy Chain.

- a) Create mesh profile and enable the Rap Ethernet Daisy chain feature.
See [Enabling RAP Ethernet Daisy Chain, on page 9](#).
- b) Attach the profile to all the RAP.
- c) Configure one AP as Super Root which should be the first hop to the wireless controller.
See [Configuring Super Root, on page 10](#).
- d) Configure primary Ethernet port on the Super Root AP if you use SFP port as uplink.
See [Configuring Primary Ethernet Port, on page 11](#).

Step 5 Enable Ethernet Bridging and Configure Ethernet port.

See [Configuring Ethernet Bridging and Ethernet Port, on page 11](#).

- a) Enable Ethernet Bridging.
- b) Ethernet port configuration on both Port 0 and Port 1, including port mode and vlan. It is recommended to configure port to trunk mode.

Step 6 Verify the behavior in daisy chain topology.

- a) Connecting the RAP via wired port one by one.

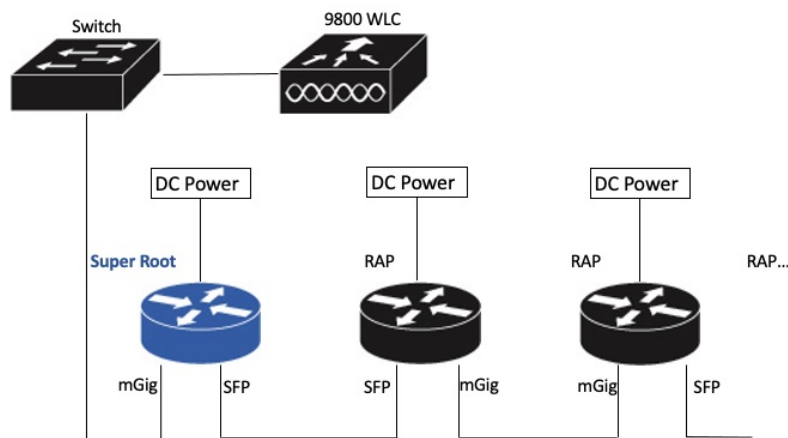

Note The RAP which is the first hop from wireless controller should be configured as Super Root, as shown in the above figure.

- b) Make sure that RAP of each hop can join the controller.

Note In field deployment, just repeat Step 6 of this procedure. Make sure you configure the first hop as Super Root.

Enabling RAP Ethernet Daisy Chain

To enable RAP Ethernet Daisy Chain feature, use the **rap-eth-daisychain** command, or configure from GUI.

The following example shows enabling the feature from CLI:

```
#configure terminal
(config)#wireless profile mesh default-mesh-profile
(config-wireless-mesh-profile)#ethernet-bridging
(config-wireless-mesh-profile)#rap-ethernet-daisychain
```

The following figure shows enabling the feature from GUI:

Edit Mesh Profile

General
Advanced

Name*	<input type="text" value="mesh_profile"/>	Backhaul amsdu	<input checked="" type="checkbox"/>
Description	<input type="text" value="Enter Description"/>	Backhaul Client Access	<input checked="" type="checkbox"/>
Range (Root AP to Mesh AP)	<input type="text" value="12000"/>	Battery State for an AP	<input checked="" type="checkbox"/>
Multicast Mode	<input type="text" value="In-Out"/>	Full sector DFS status	<input checked="" type="checkbox"/>
IDS (Rogue/Signature Detection)	<input type="checkbox"/>	Daisychain STP Redundancy	<input type="checkbox"/>
Convergence Method	<input type="text" value="Very Fast"/>	MAP Fast Ancestor Find	<input type="checkbox"/>
Background Scanning	<input checked="" type="checkbox"/>	RAP Ethernet Daisy Chain	<input checked="" type="checkbox"/>
Channel Change Notification	<input type="checkbox"/>		
LSC	<input type="checkbox"/>		

To verify the configuration, use the **show wireless profile mesh detailed** command or **show wireless mesh ethernet daisy-chain summary** command from wireless controller, as shown in the following examples:

```
#show wireless profile mesh detailed <profile name>
```

```
...
RAP ethernet daisychain      : ENABLED
```

```
#show wireless mesh ethernet daisy-chain summary
```

AP Name	BVI MAC	BGN	Backhaul	Ethernet	STP Red	Super Root
APxxxxxx	xxxxxxx	xxxxx	Ethernet0	Up Up	NA	Enabled

Or use the **show mesh config** command on AP, as shown in the following example:

```
#show mesh config
```

```
...
RAP Ethernet Daisy Chain: Enabled
Daisy Chain Root: Disabled
```

Configuring Super Root

The first RAP which connects to the upstream switch should be configured as super root, which means it's the source of all WSTP hello. Other RAPs only start hello after receiving a hello.

You can configure the super root from wireless controller or from AP.

- From wireless controller, use the **ap name <name> [no] mesh rap-eth-daisychain super-root** command to configure a super root.

To verify the configuration, use the following command:

```
#show ap name <name> config general
...
RAP ethernet daisychain           : Enabled
Super Root                       : Enabled
```

- On AP, use the **capwap ap mesh wstp super-root** command to configure a super root.

To verify the configuration, use the following command:

```
#show mesh config
...
RAP Ethernet Daisy Chain: Enabled
Daisy Chain Root: Enabled
```

Configuring Primary Ethernet Port

Super root must use its primary Ethernet port to connect to upstream switch. For IW9167EH, the default primary Ethernet port is Ethernet port 0. To manually configure the primary Ethernet port, use the **ap name <name> mesh backhaul ethernet <0/1>** command from wireless controller.

To verify the configuration, use the following command from wireless controller:

```
#show ap name <name> config general
...
AP Primary Ethernet port           : 1
RAP ethernet daisychain           : Enabled
Super Root                         : Disabled
```

Or use the following commands on AP:

```
#show mesh config
...
RAP Ethernet Daisy Chain: Enabled
Daisy Chain Root: Enabled
AP Primary ethernet backhaul interface: 1

#show mesh adjacency parent
AdjInfo: Wired Backhaul: 1 [xx:xx:xx:xx:xx:xx]
```

Configuring Ethernet Bridging and Ethernet Port

Configuring Ethernet Bridging (CLI)

The Ethernet port on the MAPs are disabled by default. It can be enabled only by configuring Ethernet bridging on the Root AP and the other respective MAPs. Follow these steps to enable Ethernet bridging on the AP.

Step 1 Enters global configuration mode.

```
Device#configure terminal
```

Step 2 Creates a mesh profile.

```
wireless profile mesh profile-name
```

Example:

```
(config)#wireless profile mesh rap-eth-daisy
```

Step 3 ethernet-bridging**Example:**

```
(config-wireless-mesh-profile)#ethernet-bridging
```

Connects remote wired networks to each other.

Step 4 Disables VLAN transparency to ensure that the bridge is VLAN aware.

```
no ethernet-vlan-transparent
```

Example:

```
(config-wireless-mesh-profile)#no ethernet-vlan-transparent
```

Step 5 Exit global configuration mode.

```
end
```

Example:

```
(config-wireless-mesh-profile)#end
```

Example

Use the following command to verify the configuration:

```
#show wireless profile mesh detailed rap-eth-daisy
```

```
Mesh Profile Name           : rap-eth-daisy
-----
Description                  :
Bridge Group Name           : unconfigured
Strict match BGN            : DISABLED
Amsdu                        : ENABLED
Background Scan             : DISABLED
Channel Change Notification : DISABLED
Backhaul client access      : DISABLED
Ethernet Bridging           : ENABLED
Ethernet Vlan Transparent   : DISABLED
Daisy Chain SP Redundancy   : DISABLED
Full Sector DFS              : ENABLED
```

Configuring Ethernet Bridging (GUI)

Follow these steps to configure Ethernet Bridging from wireless controller GUI:

-
- Step 1** Choose **Configuration > Wireless > Mesh > Profiles**
 - Step 2** Click **Add**.
 - Step 3** In **General** tab, enter the **Name** of the mesh profile.
 - Step 4** In **Advanced** tab, uncheck the **VLAN Transparent** check box to disable VLAN transparency.
 - Step 5** In **Advanced** tab, check the **Ethernet Bridging** check box.
 - Step 6** Click **Apply to Device**.

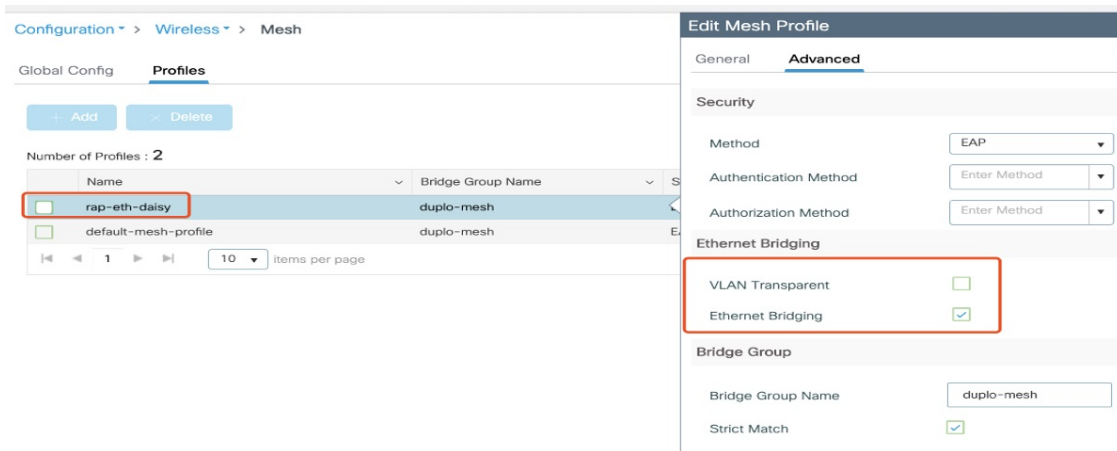

Configuring Ethernet Port (CLI)

RAP Ethernet secondary port supports Access mode and Trunk mode. Follow these steps to configure Ethernet port mode.

- Use the following command to configure access mode.

```
#ap name ap-name mesh ethernet 1 mode access Vlan-ID
```

- Use the following commands to configure trunk mode. VLAN support must be enabled in advance, and VLAN transparent should be disabled in your mesh profile.

- Configure a trunk VLAN on the corresponding RAP.

```
#ap name ap-name mesh vlan-trunking native Vlan-ID
```

- Configure the native VLAN for the trunk port.

```
#ap name ap-name mesh ethernet 1 mode trunk vlan native Vlan-ID
```

- Configure the allowed VLANs for the trunk port. Permits VLAN filtering on an ethernet port of any Mesh or Root Access Point. Active only when VLAN transparency is disabled in the mesh profile.

```
#ap name ap-name mesh ethernet 1 mode trunk allowed Vlan-ID
```

Configuring Ethernet Port (GUI)

Follow these steps to configure Ethernet port from wireless controller GUI:

Step 1 Choose **Configuration > Wireless > Access Points**.

The **All Access Points** section, which lists all the configured APs in the network, is displayed with their corresponding details.

Step 2 Click the configured mesh AP.

The **Edit AP** window is displayed.

- Step 3** Choose the **Mesh** tab.
- Step 4** In the **Ethernet Port Configuration** section, from the **Port** drop-down list, choose the port to configure.
- Step 5** From the **Mode** drop-down list, choose access mode or trunk mode.
- Step 6** In the **Native VLAN ID** field, enter the native VLAN for the trunk port.
- Step 7** Click **Update and Apply to Device**.

Edit AP

General
Interfaces
High Availability
Inventory
Mesh
Advanced
Support Bundle

General

Block Child

Daisy Chaining

Daisy Chaining strict-RAP

Preferred Parent MAC

Role

Remove PSK

Ethernet Port Configuration

! Ethernet Bridging on the associated Mesh Profile should be enabled to configure this section successfully

Port

Mode

Native VLAN ID*

Allowed VLAN IDs

Show and Debug Command

- Use the following command to debug WTP:

```
AP#debug mesh wstp
error    Mesh wstp error debugs
events   Mesh wstp events debugs
packets  Mesh wstp packet debugs
```

```
03:05:24.5918] chatter: wstp_ctl :: WstpControl: RX Hello(00) - BID:FC:58:9A:15:C8:04 SR:FC:58:9A:15:C8:04/0 Flags:02 Port:wired0
03:05:24.5918] chatter: wstp_ctl :: WstpControl - wired_hello_only, hello received, update parent record
03:05:24.5946] chatter: wstp_ctl :: WstpControl: TX Hello(00) - BID:FC:58:9A:17:58:EC SR:FC:58:9A:15:C8:04/0 Flags:02 Port:wired1
03:05:26.5918] chatter: wstp_ctl :: WstpControl: RX Hello(00) - BID:FC:58:9A:15:C8:04 SR:FC:58:9A:15:C8:04/0 Flags:02 Port:wired0
03:05:26.5918] chatter: wstp_ctl :: WstpControl - wired_hello_only, hello received, update parent record
03:05:26.5946] chatter: wstp_ctl :: WstpControl: TX Hello(00) - BID:FC:58:9A:17:58:EC SR:FC:58:9A:15:C8:04/0 Flags:02 Port:wired1
```

- Use the following command to display the WSTP statistics:

```
AP#show mesh stats
WSTP stats:
Attach-Cnt Hello-TX Hello-Rx TCN-TX TCN-RX SR-Chg-Cnt ST-Roam-Cnt
           0       58       58       0       0           0           0
```