



E

Logical Connectivity Diagrams

This appendix provides logical connectivity diagrams and related software commands for integrated controllers. It contains these sections:

- [Cisco WiSM, page 2](#)
- [Cisco 28/37/38xx Integrated Services Router, page 3](#)
- [Catalyst 3750G Integrated Wireless LAN Controller Switch, page 4](#)

This section provides logical connectivity diagrams for the controllers integrated into other Cisco products, specifically the Catalyst 3750G Integrated Wireless LAN Controller Switch, the Cisco WiSM, and the Cisco 28/37/38xx Series Integrated Services Router. These diagrams show the internal connections between the switch or router and the controller. The software commands used for communication between the devices are also provided.



Cisco WiSM

Figure 1 Logical Connectivity Diagram for the Cisco WiSM

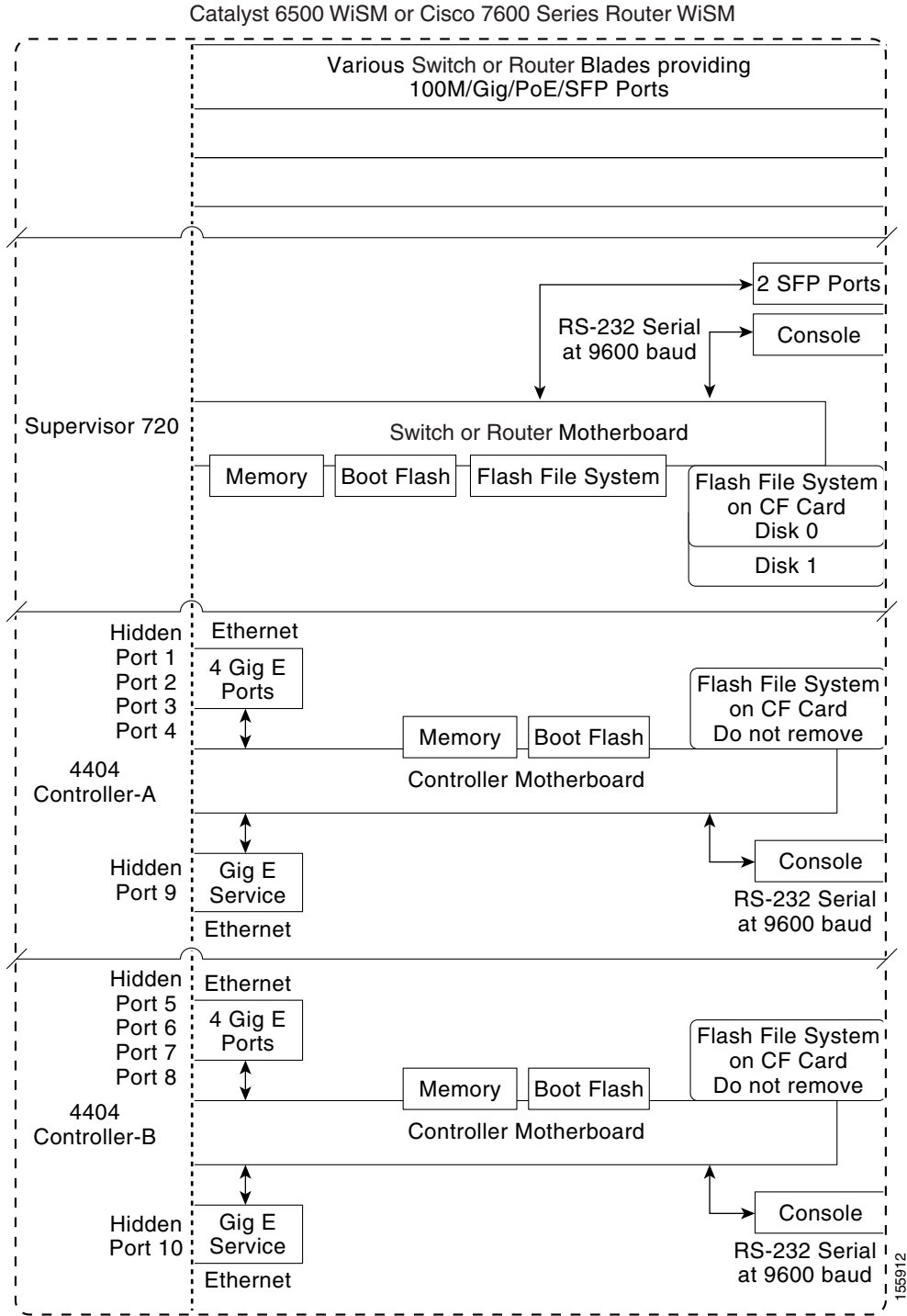

The commands used for communication between the Cisco WiSM, the Supervisor 720, and the 4404 controllers are documented in *Configuring a Cisco Wireless Services Module and Wireless Control System* at this URL:

<http://www.cisco.com/c/en/us/td/docs/wireless/technology/wism/technical/reference/appnote.html#wp39498>

Cisco 28/37/38xx Integrated Services Router

Figure 2 Logical Connectivity Diagram for the Cisco 28/37/38xx Integrated Services Router

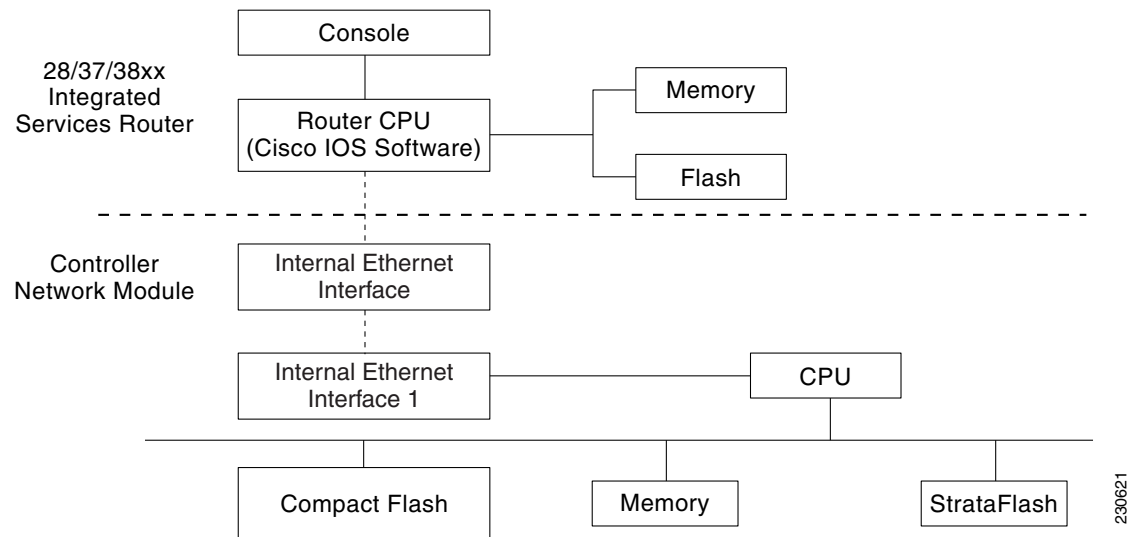

These commands are used for communication between the 28/37/38xx Integrated Services Router and the controller network module. They are initiated from the router. The commands vary depending on the version of the network module.

These commands are used for communication between the router and Fast Ethernet versions of the controller network module:

- **interface wlan-controller** *slot/unit* (and support for subinterfaces with **dot1q encap**)
- **show interfaces wlan-controller** *slot/unit*
- **show controllers wlan-controller** *slot/unit*
- **test service-module wlan-controller** *slot/unit*
- **test HW-module wlan-controller** *slot/unit* **reset** {**enable** | **disable**}
- **service-module wlan-controller** *slot/port* {**reload** | **reset** | **session** [**clear**] | **shutdown** | **status**}

These commands are used for communication between the router and Gigabit Ethernet versions of the controller network module:

- **interface integrated-service-engine** *slot/unit* (and support for subinterfaces with **dot1q encap**)
- **show interfaces integrated-service-engine** *slot/unit*
- **show controllers integrated-service-engine** *slot/unit*
- **test service-module integrated-service-engine** *slot/unit*

- `test HW-module integrated-service-engine slot/unit reset {enable | disable}`
- `service-module integrated-service engine slot/port {reload | reset | session [clear] | shutdown | status}`



Note

Refer to the *Cisco Wireless LAN Controller Network Module Feature Guide* for more information. You can find this document at this URL:
http://www.cisco.com/c/en/us/products/hw/tsd_products_support_end-of-sale_and_end-of-life_products_list.html

Catalyst 3750G Integrated Wireless LAN Controller Switch

Figure 3 Logical Connectivity Diagram for the Catalyst 3750G Integrated Wireless LAN Controller Switch

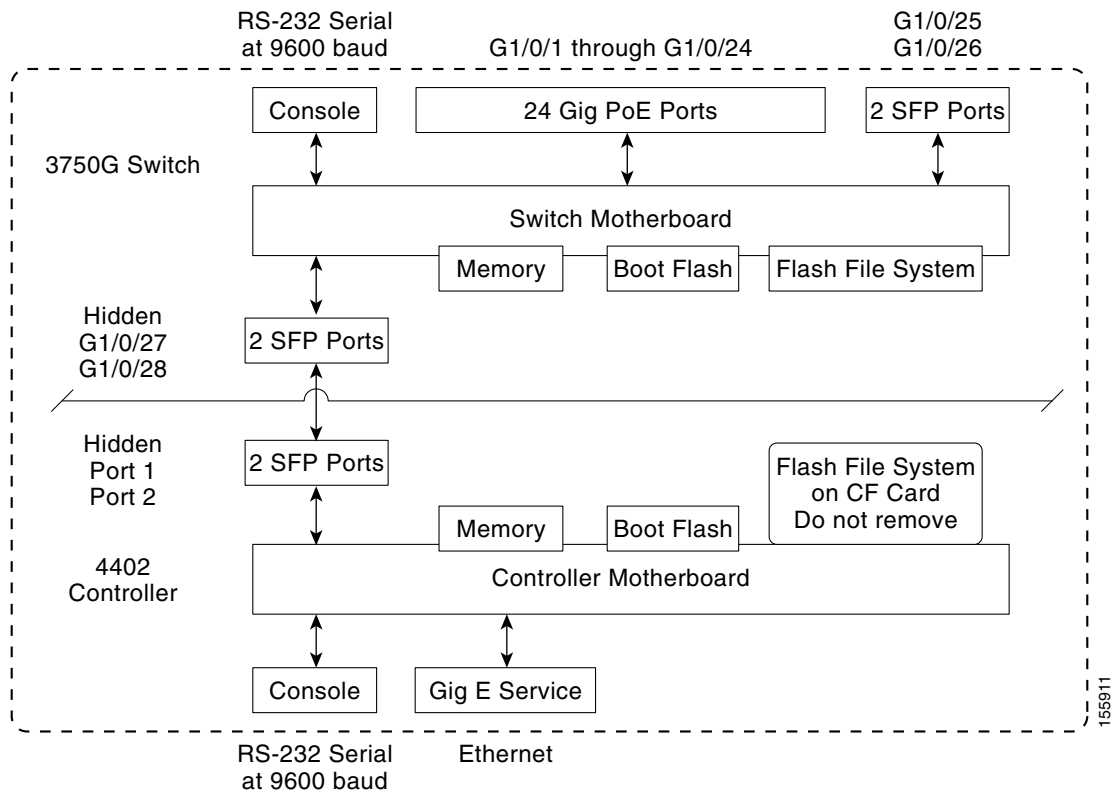

These commands are used for communication between the Catalyst 3750G switch and the 4402 controller.

Login Command

This command is used to initiate a telnet session from the switch to the controller:

session switch_number processor 1

Because there can be several switches in a stack, the *switch_number* parameter is used to indicate to which controller in the stack this session should be directed. Once a session is established, the user interacts with the controller CLI. Entering **exit** terminates the session and returns the user to the switch CLI.

Show Commands

These commands are used to view the status of the internal controller. They are initiated from the switch.

- **show platform wireless-controller *switch_number* summary**

Information similar to the following appears:

Switch	Status	State
1	up	operational
2	up	operational

- **show platform wireless-controller *switch_number* status**

Information similar to the following appears:

Switch	Service IP	Management IP	SW Version	Status
1	127.0.1.1	70.1.30.1	4.0.52.0	operational
2	127.0.1.2	70.1.31.1	4.0.45.0	operational

- **show platform wireless-controller *switch_number* management-info**

sw	vlan	ip	gateway	http	https	mac	version
1	0	70.1.30.1/16	70.1.1.1	1	1	0016.9dca.d963	4.0.52.0
2	0	70.1.31.1/16	70.1.1.1	0	1	0016.9dca.dba3	4.0.45.0

Debug Commands

The Wireless Control Protocol (WCP) is an internal keep-alive protocol that runs between the switch and the controller. It enables the switch to monitor the health of the controller and to report any problems. It uses UDP and runs over the two internal Gigabit ports, but it creates an internal VLAN 4095 to separate control traffic from data traffic. Every 20 seconds the switch sends a keep-alive message to the controller. If the controller does not acknowledge 16 consecutive keep-alive messages, the switch declares the controller dead and sends a reset signal to reboot the controller.

These commands are used to monitor the health of the internal controller.

This command is initiated from the controller.

- **debug wcp ?**

where ? is one of the following:

packet—Debugs WCP packets.

events—Debugs WCP events.

Information similar to the following appears:

```
Tue Feb 7 23:30:31 2006: Received WCP_MSG_TYPE_REQUEST
Tue Feb 7 23:30:31 2006: Received WCP_MSG_TYPE_REQUEST,of type WCP_TLV_KEEP_ALIVE
Tue Feb 7 23:30:31 2006: Sent WCP_MSG_TYPE_RESPONSE,of type WCP_TLV_KEEP_ALIVE
Tue Feb 7 23:30:51 2006: Received WCP_MSG_TYPE_REQUEST
Tue Feb 7 23:30:51 2006: Received WCP_MSG_TYPE_REQUEST,of type WCP_TLV_KEEP_ALIVE
Tue Feb 7 23:30:51 2006: Sent WCP_MSG_TYPE_RESPONSE,of type WCP_TLV_KEEP_ALIVE
Tue Feb 7 23:31:11 2006: Received WCP_MSG_TYPE_REQUEST
Tue Feb 7 23:31:11 2006: Received WCP_MSG_TYPE_REQUEST,of type WCP_TLV_KEEP_ALIVE
Tue Feb 7 23:31:11 2006: Sent WCP_MSG_TYPE_RESPONSE,of type WCP_TLV_KEEP_ALIVE
```

This command is initiated from the switch.

- **debug platform wireless-controller** *switch_number* ?

where ? is one of the following:

- all**—All
- errors**—Errors
- packets**—WCP packets
- sm**—State machine
- wcp**—WCP protocol

Reset Commands

These two commands (in this order) are used to reset the controller from the switch. They are not yet available but will be supported in a future release.

- **test wireless-controller stop** *switch_number*
- **test wireless-controller start** *switch_number*



Note

A direct console connection to the controller does not operate when hardware flow control is enabled on the PC. However, the switch console port operates with hardware flow control enabled.
