



Installing the Fabric Interconnect

This chapter contains the following topics:

- [Safety, on page 1](#)
- [Installation Options with Rack-Mount Kits, on page 2](#)
- [Airflow Considerations, on page 2](#)
- [Installation Guidelines, on page 2](#)
- [Unpacking and Inspecting the Fabric Interconnect, on page 3](#)
- [Installing the Fabric Interconnect Using the UCS-ACC-6536 Kit, on page 4](#)
- [Grounding the Fabric Interconnect, on page 7](#)
- [Starting the Fabric Interconnect, on page 9](#)

Safety



Warning **Statement 1071**—Warning Definition

IMPORTANT SAFETY INSTRUCTIONS

Before you work on any equipment, be aware of the hazards involved with electrical circuitry and be familiar with standard practices for preventing accidents. Read the installation instructions before using, installing, or connecting the system to the power source. Use the statement number provided at the end of each warning statement to locate its translation in the translated safety warnings for this device.

SAVE THESE INSTRUCTIONS



Warning This unit is intended for installation in restricted access areas. Only skilled, instructed, or qualified personnel can access a restricted access area.



Warning **Statement 1030**—Equipment Installation

Only trained and qualified personnel should be allowed to install, replace, or service this equipment.

Installation Options with Rack-Mount Kits

The rack-mount kit enables you to install the fabric interconnect into racks of varying depths. You can position the fabric interconnect with easy access to either the port connections or the fan and power supply modules.

You can install the fabric interconnect using the its accessory kit (UCS-ACC-6536=), which you can order from Cisco. This option offers you easy installation, greater stability, increased weight capacity, added accessibility, and improved removability with front and rear removal.

The rack or cabinet that you use must meet the requirements listed in the [General Requirements for Cabinets and Racks](#) section.



Note You are responsible for verifying that your rack and rack-mount hardware comply with the guidelines that are described in the referenced document.

Airflow Considerations

The fabric interconnect comes with fan and power supply modules that have port-side exhaust airflow for cooling the fabric interconnect. Make sure to position the fabric interconnect so that its port-side exhaust fan modules draw air from the cold aisle into the fabric interconnect and vent air into the hot aisle. All fan modules must have the same direction of airflow.

Installation Guidelines

When installing the fabric interconnect, follow these guidelines:

- Ensure that there is adequate clearance space around the fabric interconnect to allow for servicing the fabric interconnect and for adequate airflow.
- Ensure that the chassis can be adequately grounded. If the fabric interconnect is not mounted in a grounded rack, we recommend connecting the system ground on the chassis directly to an earth ground.
- Ensure that the site power meets the power requirements for the fabric interconnect. If available, you can use an uninterruptible power supply (UPS) to protect against power failures.



Caution Avoid UPS types that use ferroresonant technology. These UPS types can become unstable with the fabric interconnect, which can have substantial current draw fluctuations because of fluctuating data traffic patterns.

- Ensure that circuits are sized according to local and national codes. Typically, this often requires one or both of the following:
 - AC power supplies typically require at least a 15-A or 20-A AC circuit, 100 to 240 VAC, and a frequency of 50 to 60 Hz.



Caution To prevent loss of input power, ensure the total maximum loads on the circuits supplying power to the fabric interconnect are within the current ratings for the wiring and breakers.



Note For AC input application, please refer to the statement below:



Warning **Statement 1005**—Circuit Breaker

This product relies on the building's installation for short-circuit (overcurrent) protection. Ensure that the protective devices is rated not greater than 20A (North America), 16A (Europe), and 13A (UK).

Unpacking and Inspecting the Fabric Interconnect

Before you install the fabric interconnect, be sure to unpack and inspect the fabric interconnect for damage or missing components. If anything is missing or damaged, contact your customer service representative immediately.



Tip Keep the shipping container in case the chassis requires shipping at a later time.

Before you begin

Before you unpack the fabric interconnect and before you handle any fabric interconnect components, be sure that you are wearing a grounded electrostatic discharge (ESD) strap. To ground the strap, attach it directly to an earth ground or to a grounded rack or grounded chassis (there must be a metal-to-metal connection to the earth ground).

Procedure

-
- Step 1** Compare the shipment to the equipment list provided by your customer service representative and verify that you have received all items, including the following:
- Accessory Kit
- Step 2** Check for damage and report any discrepancies or damage to your customer service representative. Have the following information ready:
- Invoice number of shipper (see packing slip)
 - Model and serial number of the damaged unit

- Description of damage
 - Effect of damage on the installation
-

Installing the Fabric Interconnect Using the UCS-ACC-6536 Kit

To install the fabric interconnect, you must attach front and rear mounting brackets to the fabric interconnect, install slider rails on the rear of the rack, slide the fabric interconnect onto the slider rails, and secure the fabric interconnect to the front of the rack. Typically, the front of the rack is the side easiest to access for maintenance.



Note You must supply the eight 10-32 or 12-24 screws required to mount the slider rails and fabric interconnect to the rack.

Before you begin

- You have inspected the fabric interconnect shipment to ensure that you have everything ordered.
- Make sure that the fabric interconnect rack-mount kit includes the following parts:
 - Front rack-mount brackets (2)
 - Rear rack-mount brackets (2)
 - Slider rails (2)
 - M4 x 0.7 x 8-mm Phillips countersink screws (12)
- The rack is installed and secured to its location.

Procedure

Step 1

Install two front rack-mount brackets and the two rear rack-mount brackets to the fabric interconnect as follows:

- a) Position the fabric interconnect so that its fan and power supply modules will be in the cold aisle.
- b) Position the front rack-mount bracket and the rear rack-mount bracket so that its screw holes are aligned to the screw holes on the side of the chassis.

Note You can align the holes in the rack-mount bracket to the holes on the side of the chassis (see the two ways to mount these brackets on a typical chassis, in following figure). The holes that you use depend on the requirements of your rack and the amount of clearance required for interface cables (3 inches [7.6 mm] minimum) and module handles (1 inch [2.5 mm] minimum).

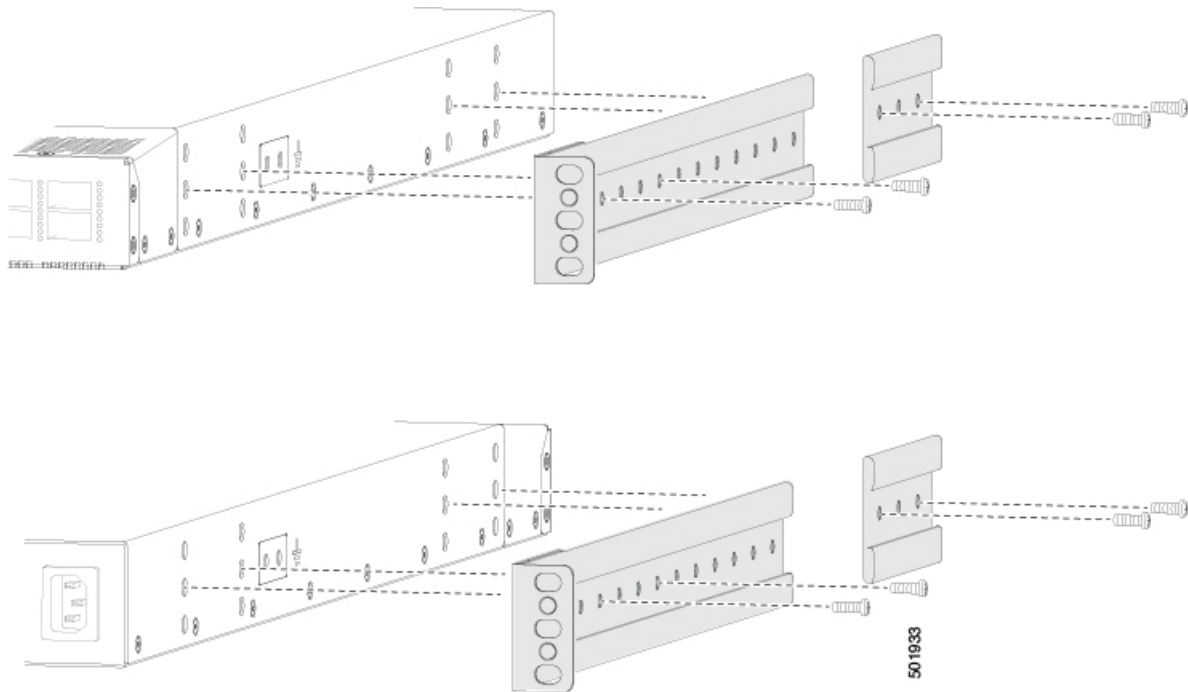

- c) Secure the front-mount bracket and the back-mount bracket to the chassis using four M4 screws and tighten each screw to 12 in-lb (1.36 N·m) of torque.
- d) Repeat Step 1 for the other front rack-mount bracket and the other back-mount bracket on the other side of the fabric interconnect and be sure to position that bracket the same distance from the front of the fabric interconnect.

Note Depending on the chassis depth, the back rack-mount bracket may not fit. In that case the back rack-mount bracket is not needed.

Step 2 If you are not installing the chassis into a grounded rack, you must attach a customer-supplied grounding wire to the chassis as explained in the [Grounding the Fabric Interconnect, on page 7](#) section. If you are installing the chassis into a grounded rack, you can skip this step.

Step 3 Install the slider rails on the rack or cabinet as follows:

- a) Determine which two posts of the rack or cabinet you should use for the slider rails. Of the four vertical posts in the rack or cabinet, two will be used for the front mount brackets attached to the easiest accessed end of the chassis, and the other two posts will have the slider rails.
- b) Position a slider rail at the desired level on the back side of the rack and use 12-24 screws or 10-32 screws, depending on the rack thread type, to attach the rails to the rack (see the following figure). Tighten 12-24 screws to 30 in-lb (3.39 N·m) of torque and tighten 10-32 screws to 20 in-lb (2.26 N·m) of torque.

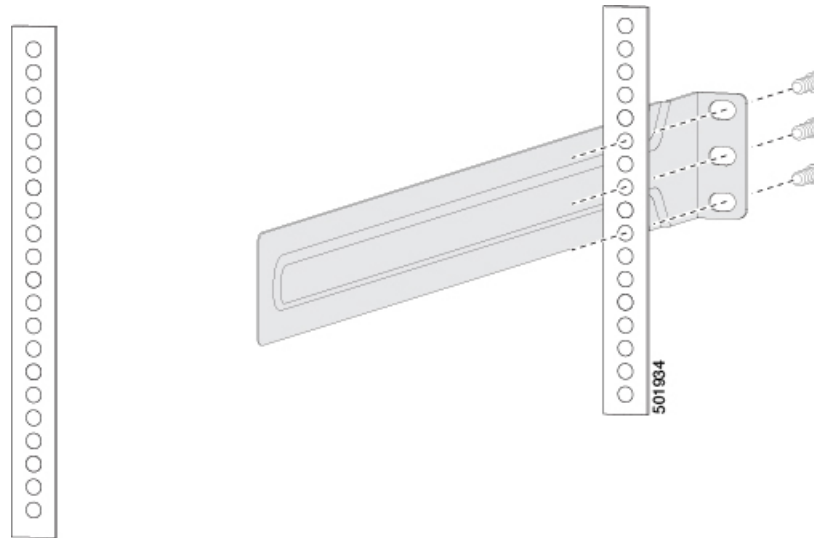

- c) Repeat Step 3 to attach the other slider rail to the other side of the rack.

To make sure that the slider rails are at the same level, you should use a level tool, tape measure, or carefully count the screw holes in the vertical mounting rails.

Step 4

Insert the fabric interconnect into the rack and attach it as follows:

- a) Holding the fabric interconnect with both hands, position the two rear rack-mount brackets on the fabric interconnect between the rack or cabinet posts that do not have slider rails attached to them (see the following figure).

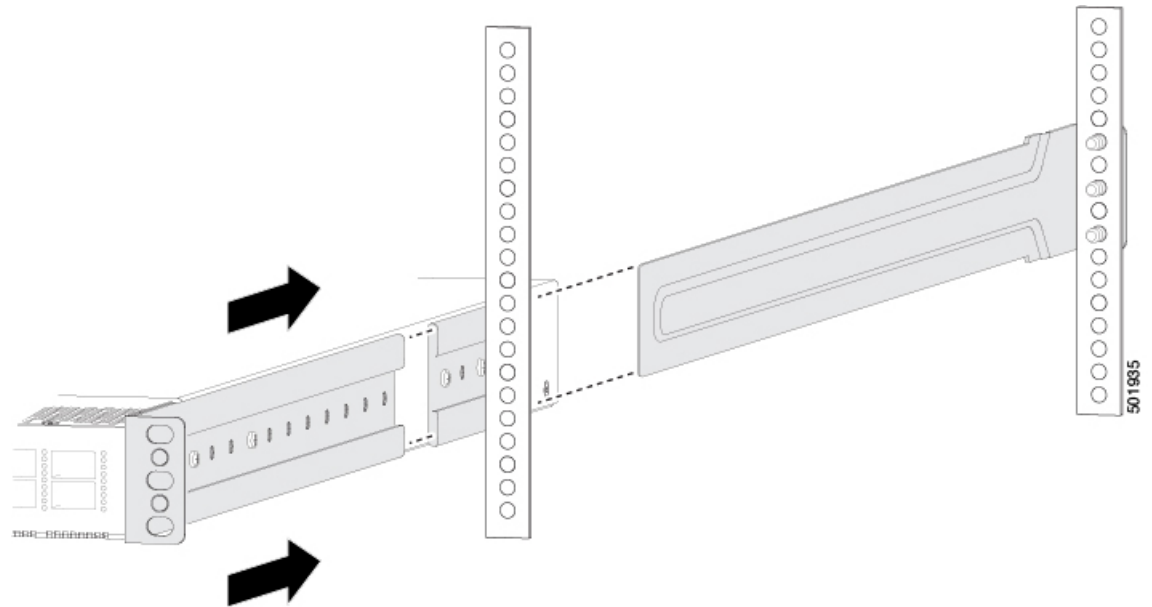

- b) Align the two rear rack-mount guides on either side of the fabric interconnect with the slider rails installed in the rack. Slide the rack-mount guides onto the slider rails, and then gently slide the fabric interconnect all the way into the rack until the front rack-mount brackets come in contact with two rack or cabinet posts.

- c) Holding the chassis level, insert screws (12-24 or 10-32, depending on the rack type) in each of the two front rack-mount brackets (using a total of six screws) and into the cage nuts or threaded holes in the vertical rack-mounting rails (see the following figure).

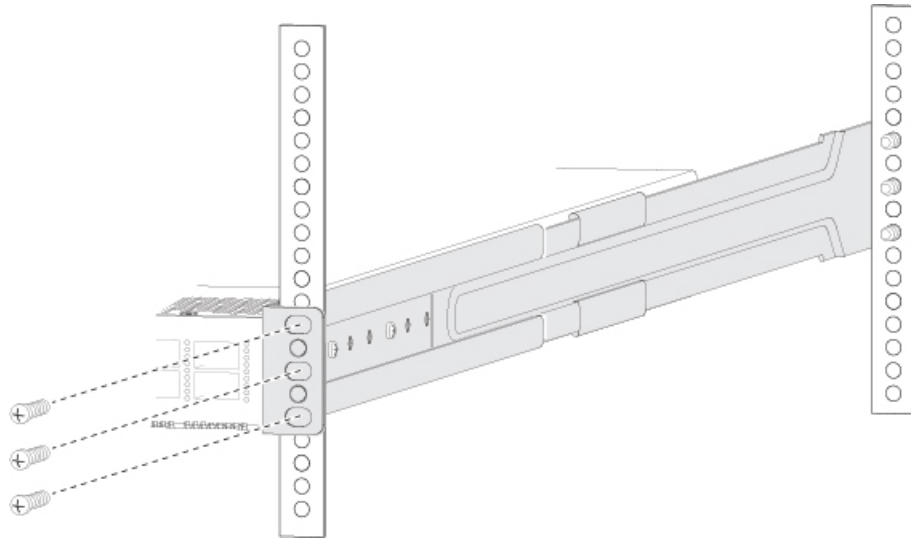

- d) Tighten the 10-32 screws to 20 in-lb (2.26 N·m) or tighten the 12-24 screws to 30 in-lb (3.39 N·m).

Step 5

If you attached a grounding wire to the chassis grounding pad, connect the other end of the wire to the facility ground.

Grounding the Fabric Interconnect

The fabric interconnect chassis is automatically grounded when you properly install the fabric interconnect in a grounded rack with metal-to-metal connections between the fabric interconnect and rack.



Note An electrical conducting path shall exist between the product chassis and the metal surface of the enclosure or rack in which it is mounted or to a grounding conductor. Electrical continuity shall be provided by using thread-forming type mounting screws that remove any paint or non-conductive coatings and establish a metal-to-metal contact. Any paint or other non-conductive coatings shall be removed on the surfaces between the mounting hardware and the enclosure or rack. The surfaces shall be cleaned and an antioxidant applied before installation.

You can also ground the chassis, which is required if the rack is not grounded, by attaching a customer-supplied grounding cable. Attach the cable to the chassis grounding pad and the facility ground.



Warning **Statement 1024—Ground Conductor**

This equipment must be grounded. To reduce the risk of electric shock, never defeat the ground conductor or operate the equipment in the absence of a suitably installed ground conductor. Contact the appropriate electrical inspection authority or an electrician if you are uncertain that suitable grounding is available.

Warning Statement 1046—Installing or Replacing the Unit

To reduce risk of electric shock, when installing or replacing the unit, the ground connection must always be made first and disconnected last.

Before you begin

Before you can ground the chassis, you must have a connection to the earth ground for the data center building.

Procedure

- Step 1** Use a wire-stripping tool to remove approximately 0.75 inch (19 mm) of the covering from the end of the grounding wire. We recommend 6-AWG wire for the U.S. installations.
- Step 2** Insert the stripped end of the grounding wire into the open end of the grounding lug. Use a crimping tool to crimp the lug to the wire, see the following figure. Verify that the ground wire is securely attached to the grounding lug by attempting to pull the wire out of the crimped lug.

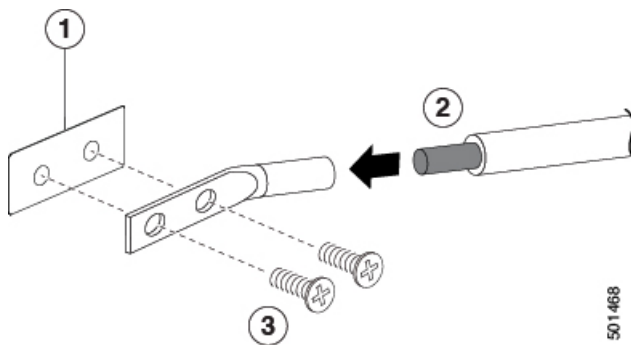

1	Chassis grounding pad	3	2 M4 screws are used to secure the grounding lug to the chassis
2	Grounding cable, with 0.75 in. (19 mm) of insulation that is stripped from one end, which is inserted into the grounding lug and crimped in place		

- Step 3** Secure the grounding lug to the chassis grounding pad with two M4 screws, see the previous figure. Tighten the screws to 11 to 15 in-lb (1.24 to 1.69 N·m) of torque.
- Step 4** Prepare the other end of the grounding wire and connect it to the facility ground.

Starting the Fabric Interconnect

You start the fabric interconnect by connecting it to its dedicated power source. If you need $n+1$ redundancy, you must connect each of the power supplies to one or two power sources. If you need $n+n$ redundancy, you must connect each power supply in a fabric interconnect to a different power source.



Note This equipment is designed to boot up in less than 30 minutes, dependent on its neighboring devices being fully up and running.

Before you begin

- The fabric interconnect must be installed and secured to a rack or cabinet.
- The fabric interconnect must be adequately grounded.
- The rack must be close enough to the dedicated power source so that you can connect the fabric interconnect to the power source by using a designated power cables.
- You have the designated power cables for the power supplies that you are connecting to the dedicated power sources.



Note Depending on the outlet receptacle on your AC power distribution unit, you might need an optional jumper power cord to connect the fabric interconnect to your outlet receptacle.

- The fabric interconnect is not connected to the network (this includes any management or interface connections).
- The fan and power supply modules are fully secured in their chassis slots.

Procedure

- Step 1** For each AC power supply, do the following:
- a) Using the recommended AC power cable for your country or region, connect one end to the AC power supply.
 - b) Connect the other end of the power cable to the AC power source.
- Step 2** Verify that the power supply LED is on and green.
- Step 3** Listen for the fans; they should begin operating when the power supply is powered.
- Step 4** After the fabric interconnect boots, verify that the following LEDs are lit:
- On the fan modules, the Status (STA or STS) LED is green.
If a fan module Status LED is not green, try reinstalling the fan module.
 - After initialization, the fabric interconnect chassis Status (labeled as STA or STS) LED is green.

- Step 5** Verify that the system software has booted, and the fabric interconnect has initialized without error messages. A setup utility automatically launches the first time that you access the fabric interconnect and guides you through the basic configuration.
-