



Cisco UCS C-Series Server Integration with Cisco UCS Manager 4.3

First Published: 2023-06-12

Last Modified: 2024-10-22

Americas Headquarters

Cisco Systems, Inc.
170 West Tasman Drive
San Jose, CA 95134-1706
USA
<http://www.cisco.com>
Tel: 408 526-4000
800 553-NETS (6387)
Fax: 408 527-0883

THE SPECIFICATIONS AND INFORMATION REGARDING THE PRODUCTS IN THIS MANUAL ARE SUBJECT TO CHANGE WITHOUT NOTICE. ALL STATEMENTS, INFORMATION, AND RECOMMENDATIONS IN THIS MANUAL ARE BELIEVED TO BE ACCURATE BUT ARE PRESENTED WITHOUT WARRANTY OF ANY KIND, EXPRESS OR IMPLIED. USERS MUST TAKE FULL RESPONSIBILITY FOR THEIR APPLICATION OF ANY PRODUCTS.

THE SOFTWARE LICENSE AND LIMITED WARRANTY FOR THE ACCOMPANYING PRODUCT ARE SET FORTH IN THE INFORMATION PACKET THAT SHIPPED WITH THE PRODUCT AND ARE INCORPORATED HEREIN BY THIS REFERENCE. IF YOU ARE UNABLE TO LOCATE THE SOFTWARE LICENSE OR LIMITED WARRANTY, CONTACT YOUR CISCO REPRESENTATIVE FOR A COPY.

The Cisco implementation of TCP header compression is an adaptation of a program developed by the University of California, Berkeley (UCB) as part of UCB's public domain version of the UNIX operating system. All rights reserved. Copyright © 1981, Regents of the University of California.

NOTWITHSTANDING ANY OTHER WARRANTY HEREIN, ALL DOCUMENT FILES AND SOFTWARE OF THESE SUPPLIERS ARE PROVIDED "AS IS" WITH ALL FAULTS. CISCO AND THE ABOVE-NAMED SUPPLIERS DISCLAIM ALL WARRANTIES, EXPRESSED OR IMPLIED, INCLUDING, WITHOUT LIMITATION, THOSE OF MERCHANTABILITY, FITNESS FOR A PARTICULAR PURPOSE AND NON-INFRINGEMENT OR ARISING FROM A COURSE OF DEALING, USAGE, OR TRADE PRACTICE.

IN NO EVENT SHALL CISCO OR ITS SUPPLIERS BE LIABLE FOR ANY INDIRECT, SPECIAL, CONSEQUENTIAL, OR INCIDENTAL DAMAGES, INCLUDING, WITHOUT LIMITATION, LOST PROFITS OR LOSS OR DAMAGE TO DATA ARISING OUT OF THE USE OR INABILITY TO USE THIS MANUAL, EVEN IF CISCO OR ITS SUPPLIERS HAVE BEEN ADVISED OF THE POSSIBILITY OF SUCH DAMAGES.

Any Internet Protocol (IP) addresses and phone numbers used in this document are not intended to be actual addresses and phone numbers. Any examples, command display output, network topology diagrams, and other figures included in the document are shown for illustrative purposes only. Any use of actual IP addresses or phone numbers in illustrative content is unintentional and coincidental.

All printed copies and duplicate soft copies of this document are considered uncontrolled. See the current online version for the latest version.

Cisco has more than 200 offices worldwide. Addresses and phone numbers are listed on the Cisco website at www.cisco.com/go/offices.

Cisco and the Cisco logo are trademarks or registered trademarks of Cisco and/or its affiliates in the U.S. and other countries. To view a list of Cisco trademarks, go to this URL: <https://www.cisco.com/c/en/us/about/legal/trademarks.html>. Third-party trademarks mentioned are the property of their respective owners. The use of the word partner does not imply a partnership relationship between Cisco and any other company. (1721R)

© 2023–2024 Cisco Systems, Inc. All rights reserved.



CONTENTS

PREFACE

Preface	vii
Audience	vii
Conventions	vii
Related Cisco UCS Documentation	ix
Documentation Feedback	ix

CHAPTER 1

Cisco UCS C-Series Integration with Cisco UCS Manager	1
Overview	1
Integrating C-Series Rack Mount Server with Cisco UCS Manager	2
FEX Connection Mode and Discovery	4
Maximum Configurable vNICs/vHBAs Based on Number of FEX Uplinks	5
Supported Adapter Cards	6
Cisco UCS Fabric Interconnect Server Compatibility Matrix	7
Network Topology and Supported Cables	12
Supported RAID/Storage Controller Configurations	14
Supported FlexFlash Configuration	24
Converting Cisco Nexus Switch to 93180YC-FX3 FEX	24
Discovering 93180YC-FX3 FEX in Cisco UCS Manager	25

CHAPTER 2

Configuring SingleConnect	27
SingleConnect	27
Management Connection Policy and Connection Mode	27
Manually Acknowledging Connection Mode	28
Manually Acknowledging Connection Mode - GUI	28
Manually Acknowledging Connection Mode - CLI	28
Requirements for SingleConnect Integration with Cisco UCS Manager	29

Requirements for Cluster Setup	29
Requirements for Non-Cluster Setup	32
Cisco UCS Manager for Mixed Cisco UCS VIC Setup	33
Cisco UCS Manager Management for Mixed VIC Set-up	33
Cisco UCS Manager Management for Mixed VIC Set-up	33
Cisco UCS Manager Management for Mixed VIC Set-up in C240 M5 Server	33
Cisco UCS Manager Management for Mixed VIC Set-up in C220 M6 Server	34
Cisco UCS Manager Management for Mixed VIC Set-up in C240 M6 Server	36
Cisco UCS Manager Management for Mixed VIC Set-up in C245 M6 Server	37
Cisco UCS Manager Management for Mixed VIC Set-up in C245 M8 Server	38
Cisco UCS Manager Management for Mixed VIC Set-up in C225 M8 Server	39
Connecting the C-Series Server with Cisco UCS Domain in Cluster Setup	41
Connecting the C-Series Server with Cisco UCS Domain in Cluster Setup	41
Physical Connectivity Illustrations for SingleConnect Cluster Setup	42
Connecting the C-Series Server with Cisco UCS Domain in Non-Cluster Setup	43
Connecting the C-Series Server with UCS Domain in Non-cluster Setup	43
Physical Connectivity Illustrations for SingleConnect Non-Cluster Setup	44
Managing the Rack-Mount Server in Cisco UCS Manager after Integration	45
Reverting a Server From Cisco UCS Domain Mode to Standalone Mode	45
Special Considerations for Integrated Servers	46
FEX Considerations	46
Cisco VIC 1455 and 1457 Connectivity	46
Cisco VIC 1467 and VIC 15428 Connectivity	46

CHAPTER 3**Configuring Direct Connect 47**

Direct Connect Mode	47
Management Connection Policy and Connection Mode	48
Requirements for Direct Connect Mode Integration with Cisco UCS Manager	48
Requirements for Cluster Setup	48
Non-Cluster Setup	51
Cisco UCS Manager for Mixed Cisco UCS VIC Setup	51
Cisco UCS Manager Management for Mixed VIC Set-up	51
Cisco UCS Manager Management for Mixed VIC Set-up	52
Cisco UCS Manager Management for Mixed VIC Set-up in C240 M5 Server	52

Cisco UCS Manager Management for Mixed VIC Set-up in C220 M6 Server	53
Cisco UCS Manager Management for Mixed VIC Set-up in C240 M6 Server	55
Cisco UCS Manager Management for Mixed VIC Set-up in C245 M6 Server	56
Cisco UCS Manager Management for Mixed VIC Set-up in C245 M8 Server	57
Cisco UCS Manager Management for Mixed VIC Set-up in C225 M8 Server	58
Connecting the C-Series Server with Cisco UCS Domain in Cluster Setup	60
Connecting the C-Series Server with Cisco UCS Domain in Cluster Setup	60
Physical Connectivity Illustrations for Direct Connect Mode Cluster Setup	61
Connecting the C-Series Server with Cisco UCS Domain in Non-Cluster Setup	63
Connecting the C-Series Server with UCS Domain in Non-Cluster Setup	63
Physical Connectivity Illustrations for Direct Connect Mode Non-Cluster Setup	63
Migrating C-Series Servers from SingleConnect to Direct Connect Mode	64
Migrating C-Series Servers from Dual-wire Management to Direct Connect Mode	65
Managing the Rack-Mount Server in Cisco UCS Manager after Integration	66
Reverting a Server From Cisco UCS Domain Mode to Standalone Mode	66
Special Considerations for Integrated Servers	67
Single Link Port Channel between VIC 1455, VIC 1457, or VIC 1467 Adapters and Cisco UCS 6300 Fabric Interconnects	67

CHAPTER 4**Configuring Dual-Wire Management 69**

Dual-Wire Management	69
Requirements or Dual_Wire Integration with Cisco UCS Manager	69
Requirements for Cluster Setup	69
Requirements for Non-Cluster Setup	72
Connecting the C-Series Server with Cisco UCS Domain in Cluster Setup	72
Connecting the C-Series Server with Cisco UCS Domain in Cluster Setup	72
Physical Connectivity Illustrations for Cluster Setup	73
Connecting the C-Series Server with Cisco UCS Domain in Non-Cluster Setup	74
Connecting the C-Series Server with UCS Domain in Non-cluster Setup	74
Managing the Rack-Mount Server in Cisco UCS Manager after Integration	75
Reverting a Server From Cisco UCS Domain Mode to Standalone Mode	75
Special Considerations for Integrated Servers	76
Supported FEX-to-FI Uplink Cable SFP Types	76
Integrated Server Power States vs Service Profile Power States	77

Cautions and Limitations for Adapter Cards 77

FEX Considerations 77

CHAPTER 5

Upgrading Earlier Release Version Servers for Cisco UCS Manager Integration 79

Required Items for Upgrade 79

Upgrading the C-Series Server Firmware 80

Updating Cisco UCS VIC Firmware and uboot Image in Integrated Servers 82

Migrating the Configuration to Release 3.1 or Higher 84

CHAPTER 6

Troubleshooting 87

Replacing a Hardware Component on a Cisco UCS Manager Integrated C-Series Server 87

Changing Server Connectivity 88



Preface

- [Audience, on page vii](#)
- [Conventions, on page vii](#)
- [Related Cisco UCS Documentation, on page ix](#)
- [Documentation Feedback, on page ix](#)

Audience

This guide is intended primarily for data center administrators with responsibilities and expertise in one or more of the following:

- Server administration
- Storage administration
- Network administration
- Network security

Conventions

Text Type	Indication
GUI elements	GUI elements such as tab titles, area names, and field labels appear in this font . Main titles such as window, dialog box, and wizard titles appear in this font .
Document titles	Document titles appear in <i>this font</i> .
TUI elements	In a Text-based User Interface, text the system displays appears in <code>this font</code> .
System output	Terminal sessions and information that the system displays appear in <code>this font</code> .
CLI commands	CLI command keywords appear in this font . Variables in a CLI command appear in <i>this font</i> .
[]	Elements in square brackets are optional.

Text Type	Indication
{x y z}	Required alternative keywords are grouped in braces and separated by vertical bars.
[x y z]	Optional alternative keywords are grouped in brackets and separated by vertical bars.
string	A nonquoted set of characters. Do not use quotation marks around the string or the string will include the quotation marks.
<>	Nonprinting characters such as passwords are in angle brackets.
[]	Default responses to system prompts are in square brackets.
!, #	An exclamation point (!) or a pound sign (#) at the beginning of a line of code indicates a comment line.



Note Means *reader take note*. Notes contain helpful suggestions or references to material not covered in the document.



Tip Means *the following information will help you solve a problem*. The tips information might not be troubleshooting or even an action, but could be useful information, similar to a Timesaver.



Timesaver Means *the described action saves time*. You can save time by performing the action described in the paragraph.



Caution Means *reader be careful*. In this situation, you might perform an action that could result in equipment damage or loss of data.



Warning IMPORTANT SAFETY INSTRUCTIONS

This warning symbol means danger. You are in a situation that could cause bodily injury. Before you work on any equipment, be aware of the hazards involved with electrical circuitry and be familiar with standard practices for preventing accidents. Use the statement number provided at the end of each warning to locate its translation in the translated safety warnings that accompanied this device.

SAVE THESE INSTRUCTIONS

Related Cisco UCS Documentation

Documentation Roadmaps

For a complete list of all B-Series documentation, see the *Cisco UCS B-Series Servers Documentation Roadmap* available at the following URL: https://www.cisco.com/c/en/us/td/docs/unified_computing/ucs/overview/guide/UCS_roadmap.html

For a complete list of all C-Series documentation, see the *Cisco UCS C-Series Servers Documentation Roadmapdoc roadmap* available at the following URL: https://www.cisco.com/c/en/us/td/docs/unified_computing/ucs/overview/guide/ucs_rack_roadmap.html.

For information on supported firmware versions and supported UCS Manager versions for the rack servers that are integrated with the UCS Manager for management, refer to [Release Bundle Contents for Cisco UCS Software](#).

Documentation Feedback

To provide technical feedback on this document, or to report an error or omission, please send your comments to ucs-docfeedback@external.cisco.com. We appreciate your feedback.



CHAPTER 1

Cisco UCS C-Series Integration with Cisco UCS Manager

This chapter includes the following sections:

- [Overview, on page 1](#)
- [Integrating C-Series Rack Mount Server with Cisco UCS Manager, on page 2](#)
- [FEX Connection Mode and Discovery, on page 4](#)
- [Maximum Configurable vNICs/vHBAs Based on Number of FEX Uplinks, on page 5](#)
- [Supported Adapter Cards, on page 6](#)
- [Cisco UCS Fabric Interconnect Server Compatibility Matrix, on page 7](#)
- [Network Topology and Supported Cables, on page 12](#)
- [Supported RAID/Storage Controller Configurations, on page 14](#)
- [Supported FlexFlash Configuration, on page 24](#)
- [Converting Cisco Nexus Switch to 93180YC-FX3 FEX , on page 24](#)

Overview

This guide contains information and procedures for installing Cisco UCS Rack Mount Servers for integration with Cisco UCS Manager.

Cisco UCS C-Series Rack-Mount Servers are managed by the built-in standalone software, Cisco Integrated Management Controller (CIMC). When a C-Series Rack-Mount Server is integrated with Cisco UCS Manager, the Cisco IMC does not manage the server anymore. Instead it is managed with the Cisco UCS Manager software. You will manage the server using the Cisco UCS Manager GUI or Cisco UCS Manager CLI.



Important If your server is not new, make sure to reset the Cisco IMC to factory default settings before integrating the server with Cisco UCS Manager. See *Server Utilities* chapter in [Cisco UCS C-Series Integrated Management Controller GUI Configuration Guide](#) for your release to reset the server to factory default settings.

You can integrate Cisco UCS C-Series Rack-Mount Servers with Cisco UCS Manager in either one of the following setup:

- **Cluster setup:** Using two Fabric Interconnects (FIs) or two FIs with two Fabric Extenders (FEXes) to connect the C-Series Rack-Mount Server.

- **Non-cluster setup:** Using a single Fabric Interconnect or one FI with one FEX to connect the C-Series Rack-Mount Server. Cisco does not recommend operating UCS domains in Non-Cluster mode because of lack of resiliency. Complete domain outage is expected during routine maintenance upgrades.



Note For Cisco UCS C-Series Rack-Mount Servers integration with Cisco UCS Manager, Cisco VIC adapters can only be connected to Cisco UCS Fabric Interconnects and not to third-party switches.

For Cisco UCS S-Series Rack-Mount Servers integration with Cisco UCS Manager, see the [Cisco UCS S3260 Server Integration with Cisco UCS Manager](#) guide in your specific release.

Integrating C-Series Rack Mount Server with Cisco UCS Manager

Cisco UCS Manager provides three connectivity modes for Cisco UCS C-Series Rack-Mount Server management. The following are the connectivity modes:

- **Direct Connect Mode:** In this mode, a Cisco UCS VIC from a C-Series Rack-Mount Server connects directly to the Fabric Interconnect. Both management and data traffic pass through from the VIC to FI and vice versa.
- **SingleConnect (Sideband):** In this mode, a Cisco UCS VIC from a C-Series Rack-Mount Server connects to FEX and then the Fabric Interconnect. Both management and data traffic pass from VIC to FEX and FI.
- **Dual-wire Management (Shared LOM):** In this mode, shared LAN on the Motherboard (LOM) port from a C-Series Rack-Mount Server connects to FEX for the management traffic. Cisco UCS VIC connects to the FI for the data traffic.



Note Cisco UCS 6536 Fabric Interconnect does not support Dual-wire Management. Dual-Wire Management is supported only with Cisco VIC adapters and not with third-party adapters.

The general prerequisites for Dual-wire integration with Cisco UCS Manager are built into the C-Series Rack-Mount Server CIMC release 1.4(6) or later.

Based on your server model and Cisco IMC version, you can use either one of these three integration options to connect the rack server with Cisco UCS Manager.

Cisco UCS Manager runs within the fabric interconnect (FI). With earlier Cisco UCS Manager releases, you need to use Fabric Extenders to connect the C-series server with the Fabric Interconnect to enable management with Cisco UCS Manager. You can directly connect the server adapter with the Fabric Interconnect without using the Fabric Extender.

You can use any of the interfaces available with this management service to access, configure, administer, and monitor the network and server resources for all chassis connected to the fabric interconnect. For

information about the Cisco UCS 6536 Fabric Interconnect, Cisco UCS 6400 Series Fabric Interconnect, or Cisco UCS 6300 Series Fabric Interconnect, see the documentation at the following links:

- [Cisco UCS 6500 Series Fabric Interconnect documentation](#)
- [Cisco UCS 6400 Series Fabric Interconnect documentation](#)
- [Cisco UCS 6300 Series Fabric Interconnect documentation](#)

If you want to use the SingleConnect or direct connect modes see [Supported Adapter Cards, on page 6](#) and [Cisco UCS Fabric Interconnect Server Compatibility Matrix, on page 7](#) for the latest C-Series Rack-Mount Servers support matrix for release 4.3(2b).

The following table lists the supported management options:

Table 1: Supported Management Options

Servers	SingleConnect	Direct Connect Mode	Dual-wire Management
Cisco UCS C245 M8 Server	Yes	Yes	No
Cisco UCS C225 M8 Server	Yes	Yes	No
Cisco UCS C240 M7 Server	Yes	Yes	No
Cisco UCS C220 M7 Server	Yes	Yes	No
Cisco UCS C220 M6 Server	Yes	Yes	Yes
Cisco UCS C240 M6 Server	Yes	Yes	Yes
Cisco UCS C245 M6 Server	Yes	Yes	No
Cisco UCS C220 M5 Server	Yes	Yes	Yes
Cisco UCS C240 M5 Server	Yes	Yes	Yes
Cisco UCS C240 SD M5 Server	Yes	Yes	Yes
C480 M5 and C480 M5 ML servers	Yes	Yes	Yes
Cisco UCS C125 M5 Server	Yes	Yes	No

For information about the Cisco Nexus 2232PP, Cisco Nexus 2232TM-E or Cisco Nexus 2348UPQ fabric extenders (FEXes) in the configuration, see the documentation at the following link:

- [Cisco Nexus 2000 Series Fabric Extender documentation](#)

Hardware Maintenance

Replacing servers and certain adapter cards requires that the server be decommissioned and recommissioned. See the decommissioning a Rack-Mount server and recommissioning a Rack-Mount Server sections in the appropriate [Cisco UCS Manager Configuration Guide](#).

FEX Connection Mode and Discovery

You can connect the FEX to the FI in two ways. Cisco UCS Manager FI discovers the FEX based on the FEX/Chassis discovery mode. The FEX connection modes are:

- **Hard-Pinning mode:** The server facing FEX ports are pinned to the connected uplink ports when the FEX is discovered. Cisco UCS Manager pins the server-facing ports to the uplink ports based on the number of acknowledged uplink ports. After the pinning, if you add a new uplink or delete an existing uplink, you must manually acknowledge the FEX to apply the changes.
- **Port-Channel mode:** Port-Channel mode does not have pinning. A single port channel works as the uplink to all server-facing ports. And all uplink ports are members of this single port channel. If one of the uplink ports goes down, the traffic is automatically distributed to another available uplink port.

In port-channel mode, when you cable between FEX and the FI, the available virtual interface (VIF) namespace varies, depending on where the uplinks are connected to the FI ports:

- When port-channel uplinks from the FEX are connected only within a set of eight ports managed by a single chip, Cisco UCS Manager maximizes the number of VIFs used in service profiles deployed on the servers.
- If uplink connections are distributed across ports managed by separate chips, the VIF count is decreased. For example, if you connect seven members of the port channel to ports 1–7, but the eighth member to port 9, this port channel can only support VIFs as though it had one member.



Note

- Beginning with Cisco UCS Manager release 4.2, Cisco Nexus N9K-C93180YC-FX3 Fabric Extender supports Cisco UCS VIC 15428, VIC 1455, VIC1457, and VIC 1467 adapters in 25G connection. Supported adapters can be used in mixed configurations.
- The maximum number of connections supported from the N9K-C93180YC-FX3 FEX to the Fabric Interconnect is 16.

For more information on FEX discovery policies and port-channel allocation, see the appropriate [Cisco UCS Manager Configuration Guide](#).

Maximum Configurable vNICs/vHBAs Based on Number of FEX Uplinks

The following table describes maximum configurable vNICs/vHBAs on a VIC adapter based on the number of FEX uplinks:

Table 2: Cisco UCS 6536 Fabric Interconnect

Acknowledged link between FEX and FI	Maximum configurable vNICs/vHBA on a VIC
1	116
2	116
4	116
8	116
16	116

Table 3: Cisco UCS 6400 Series Fabric Interconnect

Acknowledged link between FEX and FI	Maximum configurable vNICs/vHBA on a VIC adapter
1	116
2	116
4	116
8	116
16	116

Table 4: Cisco UCS 6300 Fabric Interconnect

Acknowledged link between FEX and FI	Maximum configurable vNICs/vHBA on a VIC adapter
1	116
2	116
4	116
8	116

Supported Adapter Cards

Adapter Cards

The following table shows the supported adapter cards for C-Series Rack-Mount Servers integration with Cisco UCS Manager:

Table 5: Adapter Cards for Rack Server Integration

Adapter Model	Dual-Wire Connection	SingleWire Connection	Direct Connection
Cisco UCS VIC 15235 (UCSC-P-V5D200G)	No	Yes	Yes
Cisco UCS VIC 15425 (UCSC-P-V5Q50G)	No	Yes	Yes
Cisco UCS VIC 15238(UCSC-M-V5D200G)	No	No	Yes
CISCO UCS VIC 15428 (UCSC-M-V5Q50G)	Yes, but only on C220 M6 and C240 M6	Yes	Yes
Cisco UCS VIC 1495 (UCSC-PCIE-C100-04)	No	No	Yes
Cisco UCS VIC 1497 (UCSC-MLOM-C100-04)	No	No	Yes
Cisco UCS VIC 1467 (UCSC-M-V25-04)	Yes	Yes	Yes
Cisco UCS VIC 1477 (UCSC-M-V100-04)	No	No	Yes
Cisco UCS VIC 1455 (UCSC-PCIE-C25Q-04)	Yes	Yes	Yes
Cisco UCS VIC 1457 (UCSC-MLOM-C25Q-04)	Yes	Yes	Yes
Cisco UCS VIC 1387 (UCSC-MLOM-C40Q-03)	Yes	Yes	Yes
Cisco UCS VIC 1385 (UCSC-PCIE-C40Q-03)	Yes	Yes	Yes

Adapter Model	Dual-Wire Connection	SingleWire Connection	Direct Connection
QLogic QL45412H 40GbE ¹ (UCSC-PCIE-QD40GF)	Yes	No	No

¹ Supported only for Azure-stack solution with FI 6332/6332-16UP and the Qlogic ports should be connected to FI directly and additionally LOM ports needs to be connected to FEX for management.



Note Different generation VIC adapters are not supported in a single server. For example, if a server has two VIC cards, both these VIC adapters should be either 1400 series or 1300 series.

Cisco UCS 15000 Series VIC adapters can be mixed with 1400 series VIC adapters in M6 rack servers. For example, the VIC 15428 MLOM could be used along with 1455/1495 VIC adapter in an M6 rack-server.



Note For rack server and adapter compatibility, see the respective rack server spec sheet. For connectivity options with Cisco UCS Manager, see [Configuration Guides](#).

Cisco UCS Fabric Interconnect Server Compatibility Matrix

Table 6: Cisco UCS 6536 FI - Cisco UCS Rack Servers

Cisco VIC	Direct Attach (40/100G)	Direct Attach (4x25G or 25G QSA28)	FEX		
			93180YC-FX3 (25G server ports)	93180YC-FX3 (10G server ports)	2348 UPQ (10G server ports)
15427 (UCSC-M-V5Q50GV2)	Not Supported	All Cisco UCS C-Series M6 and M7 servers Cisco UCS C245 M8 Server Cisco UCS C225 M8 Server Note Reverse breakout is not supported.	All Cisco UCS C-Series M6 and M7 servers Cisco UCS C245 M8 Server Cisco UCS C225 M8 Server	All supported 10G PIDs	All Cisco UCS C-Series M6 and M7 servers Cisco UCS C245 M8 Server Cisco UCS C225 M8 Server
15237 (UCSC-M-V5D200GV2)	All Cisco UCS C-Series M6 and M7 servers Cisco UCS C245 M8 Server Cisco UCS C225 M8 Server	Not Supported	Not Supported	Not Supported	Not Supported

Cisco UCS Fabric Interconnect Server Compatibility Matrix

Cisco VIC	Direct Attach (40/100G)	Direct Attach (4x25G or 25G QSA28)	FEX		
			93180YC-FX3 (25G server ports)	93180YC-FX3 (10G server ports)	2348 UPO (10G server ports)
15235 (UCSC-P-V5D200G)	All Cisco UCS C-Series M6 and M7 servers Cisco UCS C245 M8 Server Cisco UCS C225 M8 Server	Not Supported	Not Supported	Not Supported	Not Supported
15238 (UCSC-M-V5D200G)	All Cisco UCS C-Series M6 and M7 servers	Not Supported	Not Supported	Not Supported	Not Supported
15425 (UCSC-P-V5Q50G)	Not Supported	All Cisco UCS C-Series M6 and M7 servers Cisco UCS C245 M8 Server Cisco UCS C225 M8 Server Note No reverse breakout supported	All Cisco UCS C-Series M6 and M7 servers Cisco UCS C245 M8 Server Cisco UCS C225 M8 Server	All supported 10G PIDs	All Cisco UCS C-Series M6 and M7 servers Cisco UCS C245 M8 Server Cisco UCS C225 M8 Server
15428 (UCSC-M-V5Q50G)	Not Supported	All Cisco UCS C-Series M6 and M7 servers Note No reverse breakout supported	All Cisco UCS C-Series M6 and M7 servers	All supported 10G PIDs	All Cisco UCS C-Series M6 and M7 servers
1497-40G/100G (UCSC-MLOMC100-04)	All Cisco UCS C-series M5 servers	Not Supported	Not Supported	Not Supported	Not Supported
1495-40G/100G (UCSC-PCIEC100-04)	All Cisco UCS C-Series M6, C-Series M5, and S-series M5 servers	Not Supported	Not Supported	Not Supported	Not Supported
1477-40G/100G (UCSC-MV100-04)	All Cisco UCS C-series M6 servers	Not Supported	Not Supported	Not Supported	Not Supported
1467-10G/25G (UCSC-MV25-04)	Not Supported	All Cisco UCS C-Series M6 servers	All Cisco UCS C-Series M6 servers	All supported 10G PIDs	All Cisco UCS C-Series M6 servers
1457-10G/25G (UCSC-MLOMC25Q-04)	Not Supported	Cisco UCS C220 M5 and C240 M5	Cisco UCS C220 M5 and C240 M5	All supported 10G PIDs	Cisco UCS C220 M5 and C240 M5
1455-10G/25G (UCSC-PCIEC25Q-04)	Not Supported	All Cisco UCS C-Series M5 and M6 servers and S-series M5 servers	All Cisco UCS C-Series M5 and M6 servers and S-series M5 servers	All supported 10G PIDs	All Cisco UCS C-Series M5 and M6 servers and S-series M5 servers
1387 - 40G (UCSC-MLOM-C40Q-03)	All Cisco UCS C-Series M5 Servers (40G)	Not Supported	Not Supported	With QSA and SFP-10G-SR only without QSA and SFP-10G-SR/LR, CU1/3/5M, ACU7M only	All Cisco UCS C-Series M5 servers (QSA at adapter)

Cisco VIC	Direct Attach (40/100G)	Direct Attach (4x25G or 25G QSA28)	FEX		
			93180YC-FX3 (25G server ports)	93180YC-FX3 (10G server ports)	2348 UPO (10G server ports)
1385 - 40G (UCSC-PCIE-C40Q-03)	All Cisco UCS C-Series M5 Servers (40G)	Not Supported	Not Supported	With QSA and SFP-10G-SR only without QSA and SFP-10G-SR/LR, CUI/3/5M, ACU7M only	All Cisco UCS C-Series M5 servers (QSA at adapter)

Table 7: Cisco UCS 6400 and 64108 FIs - Cisco UCS Rack Servers

Cisco VIC	Direct Attach (10G/25G)	Direct Attach (4x10G/4x25)	Direct Attach (40G/100G)	FEX		
				2232 PP (10G)	93180YC-FX3 (25G server ports)	93180YC-FX3 (10G server ports)
15427 (UCSC-M-V5Q50GV2)	All Cisco UCS C-Series M6 and M7 servers Cisco UCS C245 M8 Server Cisco UCS C225 M8 Server	All Cisco UCS C-Series M6 and M7 servers Cisco UCS C245 M8 Server Cisco UCS C225 M8 Server	Not Supported	Not Supported	All Cisco UCS C-Series M6 and M7 servers Cisco UCS C245 M8 Server Cisco UCS C225 M8 Server	SFP-10G-SR/SR-S only
15237 (UCSC-M-V5D200GV2)	Not Supported	Not Supported	Not Supported	Not Supported	Not Supported	Not Supported
15235 (UCSC-P-V5D200G)	Not Supported	Not Supported	Not Supported	Not Supported	Not Supported	Not Supported
15238 (UCSC-M-V5D200G)	Not Supported	Not Supported	Not Supported	Not Supported	Not Supported	Not Supported
15425 (UCSC-P-V5Q50G)	All Cisco UCS C-Series M6 and M7 servers Cisco UCS C245 M8 Server Cisco UCS C225 M8 Server	All Cisco UCS C-Series M6 and M7 servers Cisco UCS C245 M8 Server Cisco UCS C225 M8 Server	Not Supported	Not Supported	All Cisco UCS C-Series M6 and M7 servers Cisco UCS C245 M8 Server Cisco UCS C225 M8 Server	SFP-10G-SR/SR-S only
15428 (UCSC-M-V5Q50G)	All Cisco UCS C-Series M6 and M7 servers	All Cisco UCS C-Series M6 and M7 servers	Not Supported	Not Supported	All Cisco UCS C-Series M6 and M7 servers	SFP-10G-SR/SR-S only
Note	Break-out is supported (6400 side QSFP, on adapter side two ports can be connected to 1 VIC (like ports 1 and 2) Reverse-breakout : Not supported					
1495-40G/100G (UCSC-PCIE100-04)	Not Supported	Not Supported	Not Supported	Not Supported	Not Supported	Not Supported

Cisco UCS Fabric Interconnect Server Compatibility Matrix

Cisco VIC	Direct Attach (10G/25G)	Direct Attach (4x10G/4x25)	Direct Attach (40G/100G)	FEX		
				2232 PP (10G)	93180YC-FX3 (25G server ports)	93180YC-FX3 (10G server ports)
1497-40G/100G (UCSC -MLOMC100 -04)	Not Supported	Not Supported	Not Supported	Not Supported	Not Supported	Not Supported
1477-40G/100G (UCSC-MV100 -04)	Not Supported	Not Supported	Not Supported	Not Supported	Not Supported	Not Supported
1467-10G/25G (UCSC -MV25-04)	All Cisco UCS C-Series M6 servers	All Cisco UCS C-Series M6 servers	Not Supported	All Cisco UCS C-Series M6 servers	All Cisco UCS C-Series M6 servers	SFP-10G-SR/SR-S only
1457-10G/25G (UCSC-MLOM C25Q-04)	Cisco UCS C220 M5, C240 M5	Cisco UCS C220 M5, C240 M5	Not Supported	Cisco UCS C220 M5, C240 M5	Cisco UCS C220 M5, C240 M5	SFP-10G-SR/SR-S only
1455-10G/25G (UCSC-PCIEC 25Q-04)	All Cisco UCS C-Series M5 and M6 servers, and S-Series M5 servers	All Cisco UCS C-Series M5 and M6 servers, and S-Series M5 servers	Not Supported	All Cisco UCS C-Series M5 and M6 servers, and S-Series M5 servers	All Cisco UCS C-Series M5 and M6 servers, and S-Series M5 servers	SFP-10G-SR/SR-S only
1387 - 40G (UCSC-MLOM -C40Q-03)	All Cisco UCS C-Series M5 servers QSA at adapter)	Not Supported	Not Supported	All Cisco UCS C-Series M5 servers QSA at adapter)	Not Supported	With QSA and SFP-10G-SR only
1385 - 40G (UCSC-PCIE -C40Q-03)	All Cisco UCS C-Series M5 and S-Series M5 servers (Except C125 M5) QSA at adapter)	Not Supported	Not Supported	All Cisco UCS C-Series M5 and S-Series M5 servers (Except C125 M5) QSA at adapter)	Not Supported	With QSA and SFP-10G-SR only

Table 8: Cisco UCS 6300 FI - Cisco UCS Rack Servers

Cisco VIC	Direct Attach	Direct Attach (Break-out)	FEX	
			2232 PP	2348
15427 (UCSC-M-V5Q50GV2)	All Cisco UCS C-Series M6 servers	All Cisco UCS C-Series M6 servers	Not Supported	All Cisco UCS C-Series M6 servers
15237 (UCSC-M-V5D200GV2)	All Cisco UCS C-Series M6 servers	Not Supported	Not Supported	Not Supported
15235 (UCSC-P-V5D200G)	All Cisco UCS C-Series M6 servers	Not Supported	Not Supported	Not Supported

Cisco VIC	Direct Attach	Direct Attach (Break-out)	FEX	
			2232 PP	2348
15425 (UCSC-P-V5Q50G)	All Cisco UCS C-Series M6 servers	All Cisco UCS C-Series M6 servers	Not Supported	All Cisco UCS C-Series M6 servers
15428 (UCSC-M-V5Q50G)	All Cisco UCS C-Series M6 servers	All Cisco UCS C-Series M6 servers	Not Supported	All Cisco UCS C-Series M6 servers
15238 (UCSC-M-V5D200G)	All Cisco UCS C-Series M6 servers	Not Supported	Not Supported	Not Supported
1497-40G/100G (UCSC-MLOMC100-04)	Cisco UCS C220 M5, C240 M5 servers	Not Supported	Not Supported	Not Supported
1495-40G/100G (UCSC-PCIEC100-04)	All Cisco UCS C-Series M5 and M6 servers and S-Series M5 servers	Not Supported	Not Supported	Not Supported
1477-40G/100G (UCSC-MV100-04)	All Cisco UCS C-Series M6 servers	Not Supported	Not Supported	Not Supported
1467-10G/25G (UCSC-MV25-04)	All Cisco UCS C-Series M6 servers (10G speed with 6332-16UP)	All Cisco UCS C-Series M6 servers	All Cisco UCS C-Series M6 servers	All Cisco UCS C-Series M6 servers
1457-10G/25G (UCSC-MLOMC25Q-04)	Cisco UCS C220 M5 and C240 M5 (10G speed with 6332-16UP)	Cisco UCS C220 M5 and C240 M5	Cisco UCS C220 M5 and C240 M5	Cisco UCS C220 M5 and C240 M5
1455-10G/25G (UCSC-PCIEC25Q-04)	All Cisco UCS C-Series M5 and M6 servers and S-Series M5 servers (10G speed with 6332-16UP)	All Cisco UCS C-Series M5 and M6 servers and S-Series M5 servers	All Cisco UCS C-Series M5 and M6 servers and S-Series M5 servers	All Cisco UCS C-Series M5 and M6 servers and S-Series M5 servers
1387 - 40G (UCSC-MLOM-C40Q-03)	All Cisco UCS C-Series M5 servers (40G or 10G using QSA)	Not Supported	All Cisco UCS C-Series M5 servers (QSA at adapter)	All Cisco UCS C-Series M5 servers (QSA at adapter)
1385 - 40G (UCSC-PCIE-C40Q-03)	All Cisco UCS C-Series M5 servers (except UCS C125 M5) and S-Series M5 servers (40G or 10G using QSA)	Not Supported	All Cisco UCS C-Series M5 servers (except UCS C125 M5) and S-Series M5 servers (40G or 10G using QSA)	All Cisco UCS C-Series M5 servers (except UCS C125 M5) and S-Series M5 servers (40G or 10G using QSA)

Table 9: Cisco UCS 6324 FI - Cisco UCS Rack Servers

Cisco VIC	Direct Attach (10G)	Direct Attach (Break-out)
15428 (UCSC-M-V5Q50G)	Not Supported	Not Supported

Cisco VIC	Direct Attach (10G)	Direct Attach (Break-out)
15238 (UCSC-M-V5D200G)	Not Supported	Not Supported
1497-40G/100G (UCSC-MLOMC100-04)	Not Supported	Not Supported
1495-40G/100G (UCSC-PCIEC100-04)	Not Supported	Not Supported
1477-40G/100G (UCSC-MV100-04)	Not Supported	Not Supported
1467-10G/25G (UCSC-MV25-04)	Not Supported	Not Supported
1457-10G/25G (UCSC-MLOMC25Q-04)	Cisco UCS C220 M5 and C240 M5 servers	Cisco UCS C220 M5 and C240 M5 servers
1455-10G/25G (UCSC-PCIEC25Q-04)	All Cisco UCS C-Series and S-Series M5 servers	All Cisco UCS C-Series and S-Series M5 servers
1387 - 40G (UCSC-MLOM-C40Q-03)	All Cisco UCS C-Series M5 servers (QSA at the adapter)	Not Supported
1385 - 40G (UCSC-PCIE-C40Q-03)	All Cisco UCS C-Series M5 servers (QSA at the adapter)	Not Supported

Network Topology and Supported Cables

The following image is a graphical representation of the over-all network topology supported in the C-Series server integration with Cisco UCS Manager.

The images are for example purpose only. For more information on server, Cisco VIC and FEX compatibility, see [Cisco UCS Fabric Interconnect Server Compatibility Matrix](#), on page 7.

For complete list of

Figure 1: Network Topology for 6536 Fabric Interconnect with 1300/1400/15000 Series VIC Cards

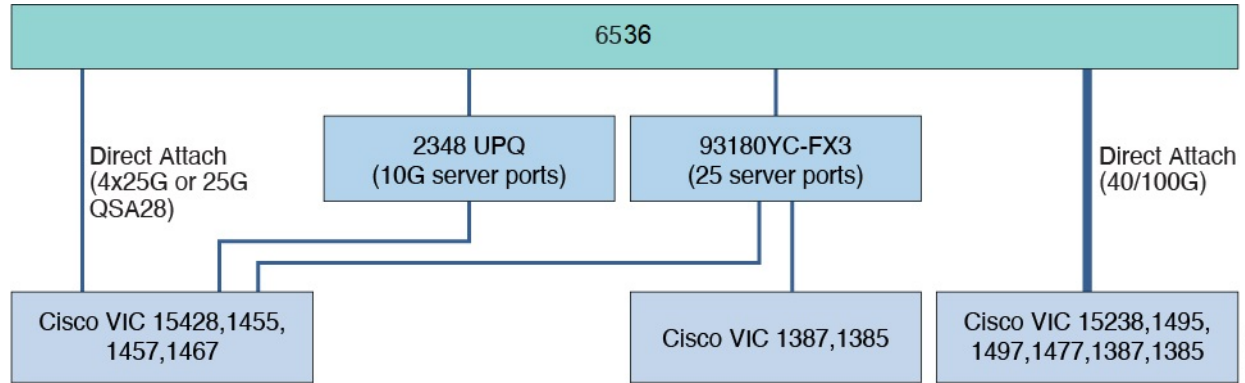
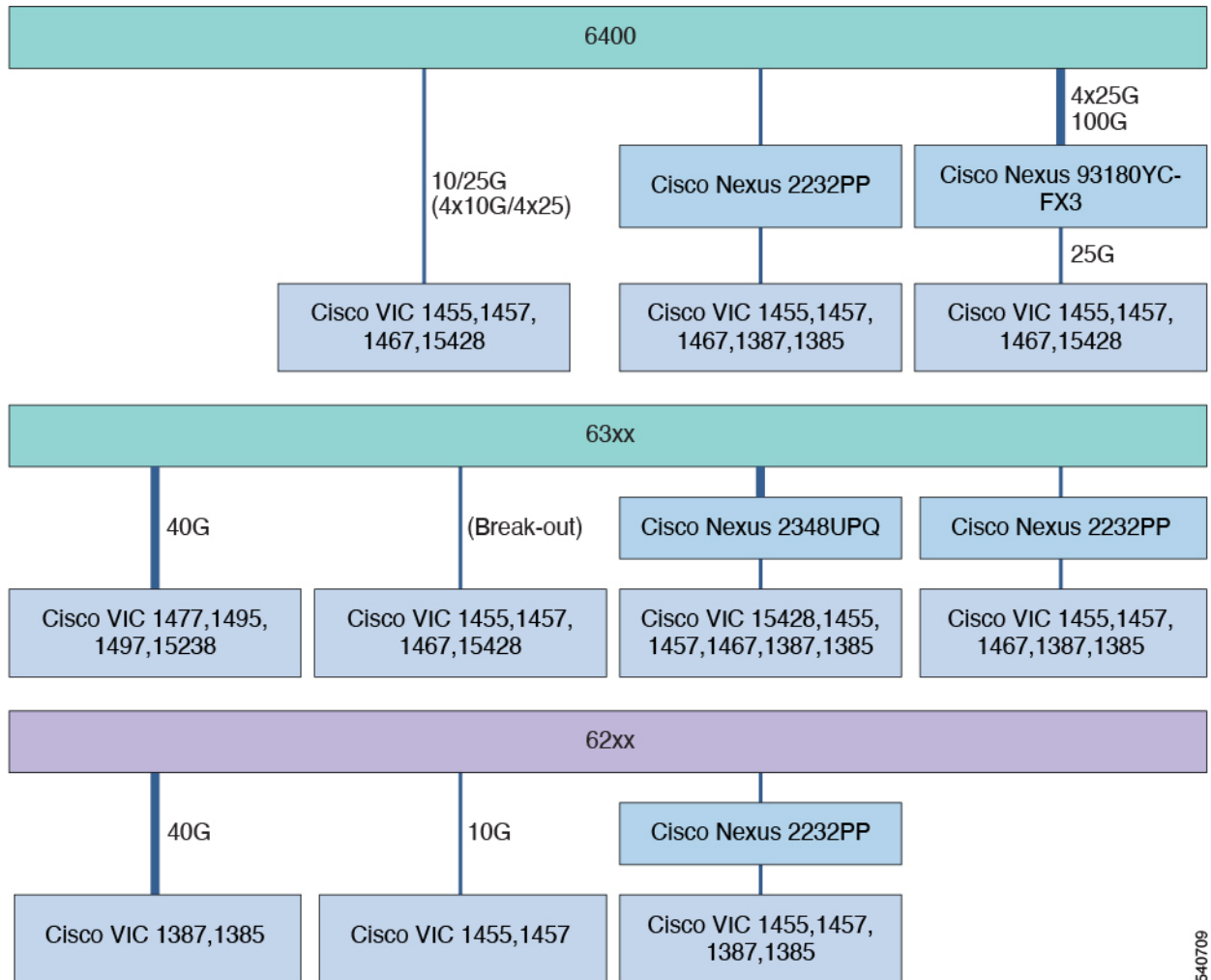

Figure 2: Network Topology for 6200, 6300, and 6400 Series Fabric Interconnect with 1300/1400/15000 Series VIC Cards



540709

For complete list of supported cables, see xxx (release notes link).

Supported RAID/Storage Controller Configurations

Only servers without expanders can have more than one RAID controllers in the Cisco UCS Manager integrated mode. The following servers are allowed to have more than one RAID controllers in the Cisco UCS Manager integrated mode:

- Cisco UCS C245 M8 Server (UCSC-C245-M8SX)
- Cisco UCS C225 M8 Server (UCSC-C225-M8S)
- Cisco UCS C225 M8 Server (UCSC-C225-M8N)
- Cisco UCS C240 M7 Server (UCSC-C240-M7SN)
- Cisco UCS C240 M7 Server (UCSC-C240-M7SX)

- Cisco UCS C220 M7 Server (UCSC-C220-M7N)
- Cisco UCS C220 M7 Server (UCSC-C220-M7S)
- Cisco UCS C220 M6 Server (USC-C220-M6S)
- Cisco UCS C220 M6 Server (USC-C220-M6N)
- Cisco UCS C240 M6 Server (USC-C240-M6S)
- Cisco UCS C240 M6 Server (USC-C240-M6SX)
- Cisco UCS C240 M6 Server (USC-C240-M6L)
- Cisco UCS C240 M6 Server (USC-C240-M6N)
- Cisco UCS C240 M6 Server (USC-C240-M6SN)
- Cisco UCS C245 M6 Server (USC-C245-M6SX)
- Cisco UCS C240 M5 (UCSC-C240-M5L)
- Cisco UCS C240 M5 (UCSC-C240-M5S)
- Cisco UCS C240 M5 (UCSC-C240-M5SX)
- Cisco UCS C240 M5 (UCSC-C240-M5SN)
- Cisco UCS C240 SD M5 (UCSC-C240-M5SD)
- Cisco UCS C220 M5 (UCSC-C220-M5L)
- Cisco UCS C220 M5 (UCSC-C220-M5SX)
- Cisco UCS C220 M5 (UCSC-C220-M5SN)
- Cisco UCS C480 M5 (UCSC-C480-M5)
- Cisco UCS C480 M5 ML Server (USC-C480-M5ML)



Note Cisco UCS C125 M5 Servers do not support multiple PICe RAID controllers. There are only 2 PCIe slots; one for a VIC card and the other for a RAID controller.

Any server not on this list that has more than one RAID controller installed, fails discovery.

The following RAID/Storage controllers are supported for C-Series rack-mount servers integration with Cisco UCS Manager.



Note A fully loaded LSI controller supports RAID 0, 1, 5, 50, 6, 10 and 60. If you remove a memory card from an LSI controller, UCS Manager cannot create RAID 6 and 10.

Table 10: Supported RAID/Storage Controllers

Server	Supported Storage Controller
Cisco UCS C245 M8 Server (UCSC-C245-M8SX)	<p>Internal storage controllers: Cisco 24G Tri-mode RAID controller</p> <p>RAID support (RAID 0, 1, 5, 6, 10, 50, 60, RAID0, and RAID00)</p> <p>Supports up to 14 internal SAS/SATA/NVMe drives</p> <p>External storage controllers:</p> <p>Cisco 12G 9500-8e 12G SAS HBA for external JBOD attach</p> <p>Small form-factor (SFF) drives, with 24-drive backplane.</p> <p>Front facing drive bays 1-24 support 2.5in SAS/SATA/NVMe SSDs depending on controller type installed.</p> <p>Optionally, front-loading drive bays 1, 2, 3, and 4 support 2.5-inch direct-attach NVMe SSDs.</p> <p>Optionally, 4 rear facing SAS/SATA/NVMe drives</p>
Cisco UCS C225 M8 Server (UCSC-C225-M8S)	<p>New tri-mode RAID controller supports SAS4 or NVMe hardware RAID</p> <p>RAID support (RAID 0, 1, 5, 6, 10, 50, 60, RAID0, and RAID00)</p> <p>Supports up to 14 internal SAS/SATA/NVMe drives</p> <p>Option for up to 4 direct-attach NVMe SSDs</p>
Cisco UCS C225 M8 Server (UCSC-C225-M8N)	<p>Option up to 10 direct attach NVMe SSDs</p> <p>All 10 NVMe drives connected at PCIe Gen4 x4</p>

Server	Supported Storage Controller
Cisco UCS C240 M7 Server (UCSC-C240-M7SN)	<p>24G Tri-mode RAID controller, 12G RAID controller or 12G SAS HBA. Only one of the raid controller can be used at a time.</p> <ul style="list-style-type: none"> • Cisco 24G Tri-mode RAID controller—RAID support (RAID 0, 1, 5, 6, 10, 50, 60, RAID0, and RAID00). Supports up to 14 internal SAS/SATA/NVMe drives • Cisco 12G RAID controller—RAID support (RAID 0, 1, 5, 6, 10, 50, 60, RAID0, and RAID00). Supports up to 28 internal SAS/SATA drives • Cisco 12G SAS HBA—No RAID support. JBOD/Pass-through Mode support. Supports up to 14 SAS/SATA internal drives • Up to 24 front facing SFF NVMe SSDs (drives are direct-attach to PCIe Gen4 x2) • Optionally, up to 4 rear NVMe drives (only) • Two CPUs are required when choosing NVMe SSDs

Server	Supported Storage Controller
Cisco UCS C240 M7 Server (UCSC-C240-M7SX)	<p>24G Tri-mode RAID controller, 12G RAID controller or 12G SAS HBA. Only one of the raid controller can be used at a time.</p> <ul style="list-style-type: none"> • Cisco 24G Tri-mode RAID controller—RAID support (RAID 0, 1, 5, 6, 10, 50, 60, RAID0, and RAID00). Supports up to 14 internal SAS/SATA/NVMe drives • Cisco 12G RAID controller—RAID support (RAID 0, 1, 5, 6, 10, 50, 60, RAID0, and RAID00). Supports up to 28 internal SAS/SATA drives • Cisco 12G SAS HBA—No RAID support. JBOD/Pass-through Mode support. Supports up to 14 SAS/SATA internal drives <p>Internal storage devices</p> <ul style="list-style-type: none"> • Up to 24 front facing SFF SAS/SATA HDDs or SAS/SATA SSDs or NVMe SSDs (optionally up to 4 of the slots can be direct-attach NVMe) • Optionally, up to four of the slots can be direct-attach NVMe. These drives must be placed in front drive bays 1, 2, 3, and 4 only. The rest of the bays (5 - 24) can be populated with SAS/SATA/NVMe SSDs or HDDs. Two CPUs are required when choosing NVMe SSDs. <p>Optionally, up to four SFF rear-facing SAS/SATA/NVMe drives</p>

Server	Supported Storage Controller
Cisco UCS C220 M7 Server (UCSC-C220-M7N)	<p>24G Tri-mode RAID controller, 12G RAID controller or 12G SAS HBA. Only one of the raid controller can be used at a time.</p> <ul style="list-style-type: none"> • Cisco 24G Tri-mode RAID controller—RAID support (RAID 0, 1, 5, 6, 10, 50, 60, RAID0, and RAID00). Supports up to 14 internal SAS/SATA/NVMe drives • Cisco 12G RAID controller—RAID support (RAID 0, 1, 5, 6, 10, 50, 60, RAID0, and RAID00). Supports up to 28 internal SAS/SATA drives • Cisco 12G SAS HBA—No RAID support. JBOD/Pass-through Mode support. Supports up to 14 SAS/SATA internal drives <p>External Storage Controller—Cisco 12G 9500-8e 12G SAS HBA for external JBOD attach.</p> <p>Internal Storage—</p> <ul style="list-style-type: none"> • Up to 10 2.5-inch direct-attach NVMe SSDs. only • The drives in slots 1, 2, 3, 4, 6, and 7 are connected to CPU 2 and the drives in slots 5, 8, 9, and 10 are connected to CPU1. Up to 4 drives are allowed with single CPU configuration. <p>Other Storage option—</p> <ul style="list-style-type: none"> • A mini-storage module connector on the motherboard supports a boot-optimized RAID controller carrier that holds up to two SATA M.2 SSDs. • 8GB FlexMMC utility storage for staging of firmware and other user data. 8GB FlexMMC storage is built into the motherboard on M7.

Server	Supported Storage Controller
Cisco UCS C220 M7 Server (UCSC-C220-M7S)	<p>24G Tri-mode RAID controller, 12G RAID controller or 12G SAS HBA. Only one of the raid controller can be used at a time.</p> <ul style="list-style-type: none"> • Cisco 24G Tri-mode RAID controller—RAID support (RAID 0, 1, 5, 6, 10, 50, 60, RAID0, and RAID00). Supports up to 14 internal SAS/SATA/NVMe drives • Cisco 12G RAID controller—RAID support (RAID 0, 1, 5, 6, 10, 50, 60, RAID0, and RAID00). Supports up to 28 internal SAS/SATA drives • Cisco 12G SAS HBA—No RAID support. JBOD/Pass-through Mode support. Supports up to 14 SAS/SATA internal drives <p>External Storage Controller—Cisco 12G 9500-8e 12G SAS HBA for external JBOD attach.</p> <p>Internal Storage—</p> <ul style="list-style-type: none"> • Up to 10 SFF SAS/SATA hard drives (HDDs) or SAS/SATA/NVMe solid state drives (SSDs). • Optionally, up to four direct-attach SFF NVMe PCIe SSDs. These drives must be placed in front drive bays 1, 2, 3, and 4 only, can be mixed with SAS/SATA drives, and are controlled from CPU 2. The rest of the bays (5 - 10) can be populated with SAS/SATA/NVMe SSDs or HDDs. Two CPUs are required when choosing direct-attach NVMe SSDs. • If using a SATA Interposer, up to 8 SATA-only drives can be installed (slots 1-4 and 6-9 only). <p>Other Storage option—</p> <ul style="list-style-type: none"> • A mini-storage module connector on the motherboard supports a boot-optimized RAID controller carrier that holds up to two SATA M.2 SSDs. • 8GB FlexMMC utility storage for staging of firmware and other user data. 8GB FlexMMC storage is built into the motherboard on M7.

Server	Supported Storage Controller
Cisco UCS C220 M6 Server (UCS-C220-M6S)	<ul style="list-style-type: none"> • Cisco 12G Modular SAS HBA (max 16 drives) (UCSC-SAS-M6T) • Cisco 12G Modular Raid controller with 2GB cache(max 16 drives) (UCSC-RAID-M6T) • 12 SFF front-facing SAS/SATA hard drives (HDDs) or SAS/SATA solid state drives (SSDs). <p>Note Drives occupy slots 1-10</p>
Cisco UCS C220 M6 Server (UCS-C220-M6N)	Up to 10 SFF NVMe PCIe SSDs.
Cisco UCS C240 M6 Server (UCS-C240-M6S)	<ul style="list-style-type: none"> • Cisco 12G Modular SAS HBA (max 16 drives) (UCSC-SAS-M6T) • Cisco 12G Modular Raid controller with 2GB cache(max 16 drives) (UCSC-RAID-M6T) • 12 SFF front-facing SAS/SATA hard drives (HDDs) or SAS/SATA solid state drives (SSDs). <p>Note Drives occupy slots 1-12</p>
Cisco UCS C240 M6 Server(UCS-C240-M6L)	<ul style="list-style-type: none"> • Cisco 12G Modular SAS HBA (max 16 drives) (UCSC-SAS-M6HD) • Cisco 12G Modular Raid controller with 2GB cache(max 16 drives) (UCSC-RAID-M6HD)
Cisco UCS C240 M6 Server(UCS-C240-M6SX)	<ul style="list-style-type: none"> • Dual Cisco 12G Modular SAS HBA (max 32 drives) (UCSC-SAS-M6T) • Cisco 12G Modular Raid controller with 2GB cache(max 16 drives) (UCSC-RAID-M6SD)
Cisco UCS C240 M6 Server(UCS-C240-M6N)	Up to 12 SFF NVMe PCIe SSDs.
Cisco UCS C240 M6 Server(UCS-C240-M6SN)	Up to 24 SFF NVMe PCIe SSDs.

Server	Supported Storage Controller
Cisco UCS C245 M6 Server(UCS-C245-M6SX)	<ul style="list-style-type: none"> • Dual-Cisco M6 12G SAS HBA controller (UCSC-RAID-M6T) (up to 16 SAS/SATA HDD) • Cisco M6 12G SAS RAID controller with 4GB FBWC (28 Drives) (UCSC-RAID-M6SD) (up to 28 SAS/SATA HDD) • M.2 Boot RAID controller (UCS-M2-HWRAID) (Hardware RAID 0/1, up to two M.2 2280 Drives) • Directly attached NVMe on rear risers (up to four NVMe SSD)
Cisco UCS C220 M5 (UCSC-C220-M5SX)	<ul style="list-style-type: none"> • Cisco 12G Modular Raid controller with 2GB cache(max 16 drives) (UCSC-RAID-M5) • Cisco 12G Modular SAS HBA (max 16 drives) (UCSC-SAS-M5)
Cisco UCS C220 M5 (UCSC-C220-M5L)	<ul style="list-style-type: none"> • Cisco UCS 12G SAS Modular 8-Port RAID Controller (UCSC-MRAID12G)
Cisco UCS C220 M5 (UCSC-C220-M5SN)	<ul style="list-style-type: none"> • Cisco UCS 12G SAS Modular 8-Port RAID Controller (UCSC-MRAID12G) or Cisco 12G Modular SAS HBA (max 16 drives) (UCSC-SAS-M5) • Up to 10 SFF NVMe PCIe SSDs. <p>Note The drives in slots 1 and 2 are connected from Riser 2 and the drives in slots 3 through 10 are connected from the PCIe switch card plugged into the internal HBA slot.</p> <p>UCSC-C220-M5SN does not support embedded RAID.</p>
Cisco UCS C240 M5 (UCSC-C240-M5S)	<ul style="list-style-type: none"> • Cisco 12G Modular Raid controller with 2GB cache(max 16 drives) (UCSC-RAID-M5) • Cisco 12G Modular SAS HBA (max 16 drives) (UCSC-SAS-M5)
Cisco UCS C240 M5 (UCSC-C240-M5L)	<ul style="list-style-type: none"> • Cisco 12G Modular Raid controller with 2GB cache(max 16 drives) (UCSC-RAID-M5) • Cisco 12G Modular SAS HBA (max 16 drives) (UCSC-SAS-M5)

Server	Supported Storage Controller
Cisco UCS C240 M5 (UCSC-C240-M5SX)	<ul style="list-style-type: none"> • Cisco 12G Modular Raid controller with 4GB cache(max 26 drives) (UCSC-RAID-M5HD) • Cisco 12G Modular SAS HBA (max 26 drives)(UCSC-SAS-M5HD)
Cisco UCS C240 M5 (UCSC-C240-M5SN)	<ul style="list-style-type: none"> • Up to eight front-facing SFF NVMe PCIe SSDs only (replacing SAS/SATA drives). <ul style="list-style-type: none"> Note These drives must be placed in front drive bays 1 through 8 only and are connected from Riser 2 slot 4 (from a PCIe switch). • 16 SFF front-facing SAS/SATA hard drives (HDDs) or SAS/SATA solid state drives (SSDs). <ul style="list-style-type: none"> Note Drives occupy slots 9-24. • Optionally, up to two SFF, rear-facing SFF NVMe PCIe SSDs (must be NVMe only). Rear facing NVMe drives are connected from Riser 2. <p>UCSC-C240-M5SN does not support embedded RAID.</p>
Cisco UCS C240 SD M5 (UCSC-C240-M5SD)	<ul style="list-style-type: none"> • Cisco 12G Modular SAS HBA (maximum of 16 drives) (UCSC-SAS-M5)
Cisco UCS C480 M5 (UCSC-C480-M5)	<ul style="list-style-type: none"> • Cisco 12G 9460-8i RAID controller with 2GB cache (UCSC-SAS9460-8I) • Cisco 12G Modular RAID (UCSC-RAID-M5HD) controller with a 4GB cache with a supercap cache backup (UCSC-SCAP-M5) • Cisco UCS C480 M5 (UCSC-C480-8AUX) Auxiliary Drive Modules for the Cisco 12G 9460-8i RAID controller
Cisco UCS C125 M5 Server (UCSC-C125)	<ul style="list-style-type: none"> • Cisco 12G 9460-8i RAID controller with 2GB cache (UCSC-SAS9460-8I) • Onboard SATA storage controller (FCH) in AHCI mode is supported • SWRAID is not supported

Server	Supported Storage Controller
Cisco UCS C480 M5 ML Server (USC-C480-M5ML)	<ul style="list-style-type: none"> • Cisco 12G Modular RAID Controller (UCSC-RAID-M5HD) Includes 4-GB cache; controls up to 26 drives

Supported FlexFlash Configuration

Some Cisco UCS C-Series Rack-Mount Servers support an internal Cisco FlexFlash Secure Digital (SD) memory card for storage of server software tools and utilities. FlexFlash is disabled by default. You can enable FlexFlash in a local disk policy used in a service profile.



Note Cisco UCS C-Series standalone servers with Cisco FlexFlash SD memory cards configured in Utility mode are not supported in the Cisco UCS Manager Integrated mode.

After upgrading CIMC if you are unable to install Cisco FlexFlash, apply the scrub policy before configuring the FlexFlash SD cards.

The FlexFlash SD cards can also be scrubbed using the format SD cards option, if the controller supports the same.

Converting Cisco Nexus Switch to 93180YC-FX3 FEX

This section describes how to convert the switch usage from switch mode to FEX mode.

Procedure

Step 1 Configure the switch in a way that it does not boot from Cisco NX-OS mode using the following command:

```
no boot nxos
```

Step 2 Copy the start-up configuration before booting the FEX image by running the following command:

```
copy running-config startup-config
```

Step 3 Set the FEX as the boot variable by running the following command:

```
boot fex
```

Note Do not run the `copy running-config startup-config` command after running the `boot fex` command.

Step 4 Reload the switch.

Here is a sample switch to FEX conversion commands:

```
switch(config)# no boot nxos
switch(config)# copy running-config startup-config
switch(config)# boot fex
switch(config)# reload
```

Discovering 93180YC-FX3 FEX in Cisco UCS Manager



Note In Cisco UCS Manager release 4.2, only the Cisco Nexus 93180YC-FX3 switch is supported in the FEX mode and Cisco Nexus 93180YC-FX3S switch in the FEX mode is not supported.

Procedure

Step 1 Log in to Cisco UCS Manager.

Step 2 Configure the server port for the 93180YC-FX3 FEX.

- a. In the Navigation pane, click **Equipment**.
- b. Expand **Equipment** > **Fabric interconnects** > **Fabric Interconnect A/B** > **Fixed Module** > **Ethernet Ports**.
- c. Click a port under the **Ethernet Ports** node.
- d. In the **Work** pane, click the **General** tab.
- e. In the **Actions** area, click **Reconfigure**.
- f. From the drop-down list, choose **Configure as Server Port**.

Step 3 In the **Actions** area, click **Show Interface** and choose **CL74** in the **FEC** field to initiate discovery of 93180YC-FX3 FEX.

Note For connecting Cisco UCS rack servers to the 93180YC-FX3 FEX, you do not require an explicit FEC configuration.

Table 11: Supported Cable and Transceiver Matrix for 93180YC-FX3

Type	Supported Cables
25GbE	<ul style="list-style-type: none"> • SFP-25G-SR-S • SFP-10/25G-LR-S • SFP-10/25G-CSR-S • SFP-H25G-CU1M • SFP-H25G-CU2M • SFP-H25G-CU3M • SFP-H25G-CU4M • SFP-H25G-CU5M • SFP-25G-AOC1M • SFP-25G-AOC2M • SFP-25G-AOC3M • SFP-25G-AOC4M • SFP-25G-AOC5M • SFP-25G-AOC7M • SFP-25G-AOC10M
100GbE	<ul style="list-style-type: none"> • QSFP-4SFP25G-CU1M • QSFP-4SFP25G-CU2M • QSFP-4SFP25G-CU3M • QSFP-4SFP25G-CU5M • QSFP-100G-SR4-S • QSFP-100G-PSM4-S



CHAPTER 2

Configuring SingleConnect

This chapter includes the following sections:

- [SingleConnect, on page 27](#)
- [Management Connection Policy and Connection Mode, on page 27](#)
- [Manually Acknowledging Connection Mode, on page 28](#)
- [Requirements for SingleConnect Integration with Cisco UCS Manager, on page 29](#)
- [Cisco UCS Manager for Mixed Cisco UCS VIC Setup, on page 33](#)
- [Cisco UCS Manager Management for Mixed VIC Set-up in C225 M8 Server, on page 39](#)
- [Connecting the C-Series Server with Cisco UCS Domain in Cluster Setup, on page 41](#)
- [Connecting the C-Series Server with Cisco UCS Domain in Non-Cluster Setup, on page 43](#)
- [Managing the Rack-Mount Server in Cisco UCS Manager after Integration, on page 45](#)
- [Reverting a Server From Cisco UCS Domain Mode to Standalone Mode, on page 45](#)
- [Special Considerations for Integrated Servers, on page 46](#)

SingleConnect

Cisco UCS Manager supports an option to integrate the C-Series Rack-Mount Server with Cisco UCS Manager using the NC-SI. This option enables Cisco UCS Manager to manage the C-Series Rack-Mount Servers using a single cable for both management traffic and data traffic. When you use the SingleConnect mode, one host facing port on the FEX is sufficient to manage one rack-mount server, instead of the two ports used in the Shared-LOM mode. This allows you to connect more number of rack-mount servers with Cisco UCS Manager for integrated server management. Make sure you have the correct server firmware for integration with Cisco UCS Manager. If not, upgrade your server firmware before integration. See [Upgrading the C-Series Server Firmware, on page 80](#).

Management Connection Policy and Connection Mode

When establishing physical connections for the C-Series Rack-Mount Server in the Cisco UCS Domain, you must specify the connection mode and management policy in Cisco UCS Manager GUI or Cisco UCS Manager CLI. The management policy is global to all connected C-Series Rack-Mount Servers. The connection mode determines the rack server discovery in Cisco UCS Manager.

You can specify either one of the following connection policies for the rack servers:

- **Auto Acknowledged:** This is the recommended and default connection mode for the C-Series Rack-Mount Server. If the connection mode is auto-acknowledged, immediately after establishing the physical connection, Cisco UCS Manager discovers the rack server and starts managing the server based on the specified management policy.
- **User Acknowledged:** If the connection mode is user-acknowledged, after establishing the physical connection, you must manually acknowledge the connection and specify the connection mode in the Cisco UCS Manager GUI or Cisco UCS Manager CLI to begin the discovery. Cisco UCS Manager does not begin the C-Series Rack-Mount Server discovery until you specify the connection mode. See [Manually Acknowledging Connection Mode - GUI, on page 28](#) or [Manually Acknowledging Connection Mode - CLI, on page 28](#) for detailed procedure.



Note When rack servers are discovered and are managed by Cisco UCS Manager, if you want to change the existing connection mode for one C-Series Rack-Mount Server, you have to decommission the server, re-commission it and specify the new connection mode. Only then Cisco UCS Manager can discover the server in the new connection mode.

Manually Acknowledging Connection Mode

Manually Acknowledging Connection Mode - GUI

If the connection mode is user-acknowledged, after establishing the physical connection, you must manually acknowledge the connection and specify the connection mode in the Cisco UCS Manager GUI to begin the discovery. Cisco UCS Manager does not begin the C-Series Rack-Mount Server discovery until you specify the connection mode.

Procedure

Step 1 Expand **Equipment** > **Rack Mounts** > **Servers**.

Note For Cisco UCS C125 M5 Servers, expand **Equipment** > **Rack Mounts** > **Enclosures** > **Rack Enclosure *rack_enclosure_number*** > **Servers**.

Step 2 Select the **Inventory** > **CIMC** tab.

Step 3 Click **Configure Management Connection** and select **Enable**.

Step 4 Select **Enabled** checkbox for **State**.

Step 5 Click **OK**.

Manually Acknowledging Connection Mode - CLI

If the connection mode is user-acknowledged, after establishing the physical connection, you must manually acknowledge the connection and specify the connection mode in the Cisco UCS Manager CLI to begin the

discovery. Cisco UCS Manager does not begin the C-Series Rack-Mount Server discovery until you specify the connection mode.

SUMMARY STEPS

1. UCS-A# **scope server_ID**
2. UCS-A/server # **scope cimc**
3. UCS-A/server/cimc # **scope mgmt-conn sideband**
4. UCS-A/server/cimc/mgmt-conn #**set mgmt-conn-state enabled**
5. UCS-A/server/cimc/mgmt-conn* # **commit-buffer**

DETAILED STEPS

Procedure

	Command or Action	Purpose
Step 1	UCS-A# scope server_ID	Enters the specified server.
Step 2	UCS-A/server # scope cimc	Enters the CIMC mode.
Step 3	UCS-A/server/cimc # scope mgmt-conn sideband	Enters the management connection mode.
Step 4	UCS-A/server/cimc/mgmt-conn # set mgmt-conn-state enabled	Acknowledges the connection mode.
Step 5	UCS-A/server/cimc/mgmt-conn* # commit-buffer	Saves the changes in the system.

Example

```
UCS-A# scope server 1
UCS-A /server # scope cimc
UCS-A /server/cimc # scope mgm
UCS-A /server/cimc # scope mgmt-conn
UCS-A /server/cimc # scope mgmt-conn sideband
UCS-A /server/cimc/mgmt-conn # set mgmt-conn-state enabled
UCS-A /server/cimc/mgmt-conn* # commit-buffer
UCS-A /server/cimc/mgmt-conn
```

Requirements for SingleConnect Integration with Cisco UCS Manager

Requirements for Cluster Setup

You must have the following items to create a single-wire integration for C-Series Rack-Mount Server with Cisco UCS Manager in a cluster setup:

- A Cisco UCS system that is running Cisco UCS Manager.

- Any of the C-Series Rack-Mount Servers and corresponding Cisco IMC and UCS Manager release versions listed in [Table 12: Minimum Required Version of Cisco IMC, BIOS and Cisco UCS Manager, on page 30](#).
- Two Cisco UCS VIC cards and two Cisco UCS FIs. See [Cisco UCS Fabric Interconnect Server Compatibility Matrix, on page 7](#) for adapter and FI compatibility with your server. To enable SingleConnect for the Cisco UCS Manager integration, you must have a Cisco VIC installed in the specific slot assigned for SingleConnect in the rack server. If the VIC is not in the specific slot, SingleConnect does not work.

Minimum Required Version of Cisco IMC, BIOS and Cisco UCS Manager for SingleConnect Integration

Table 12: Minimum Required Version of Cisco IMC, BIOS and Cisco UCS Manager

Server	Cisco IMC	Cisco IMC BIOS	Cisco UCS Manager	UCS Manager (BIOS)
Cisco UCS C225 M8 Server	4.3(5.240021)	43.5a00904241155.gbin	4.3(5a)	C225M8.4.3.5a.0.0904241155.gbin
Cisco UCS C245 M8 Server	4.3(4.241014)	C245M8.4.3.4a.0.0520240849	4.3(4b)	ucs-c245-m8-bios.C245M8.4.3.4a.0.0520240849.bin
Cisco UCS C240 M7 Server	4.3.1.230097	C240M7.4.3.1a.0	4.3(2b)	ucs-c240-m7-bios.C240M7.4.3.2a.0.0710230213.bin
Cisco UCS C220 M7 Server	4.3.1.230097	C220M7.4.3.1a.0	4.3(2b)	ucs-c220-m7-bios.C220M7.4.3.2a.0.0710230213.bin
Cisco UCS C220 M6 Server	4.2(1)	4.2(1)	4.2(1)	4.2(1)
Cisco UCS C240 M6 Server	4.2(1)	4.2(1)	4.2(1)	4.2(1)
Cisco UCS C220 M5 Server	3.1.1d	3.1.1i.0	3.2(1d)	3.1.1i.0
Cisco UCS C245 M6 Server	4.2(1)	4.2(1)	4.2(1)	4.2(1)
Cisco UCS C240 M5 Server	3.1.1d	3.1.1h.0	3.2(1d)	3.1.1h.0
Cisco UCS C480 M5 Server	3.1(2b)	3.1.2a.0	3.2(2b)	3.1.2a.0
Cisco UCS C480 M5 Server	3.1(2b)	3.1.2a.0	3.2(2b)	3.1.2a.0
Cisco UCS C125 M5 Server	4.0(1a)	4.0(1a)	4.0(1a)	4.0(1a)
Cisco UCS C480 M5 ML Server	4.0(2a)	4.0(2a)	4.0(2a)	4.0(2a)
Cisco UCS C240 SD M5 Server	4.1(2)	4.1(2)	4.1(2)	4.1(2)

Recommended Cisco VIC Firmware Version

Table 13: Recommended Cisco VIC Firmware Version

Server	VIC Firmware Version
Cisco UCS VIC 15238	5.3(2.32)
Cisco UCS VIC 15235	5.3(2.32)-48
Cisco UCS VIC 15425	5.3(2.32)-48
For Cisco UCS VIC 15428 MLOM	5.3(2.32)-48
Cisco UCS VIC 1495	5.3(2.32)
For Cisco UCS VIC 1467 and 1477 MLOM:	5.3(2.32)

Server	VIC Firmware Version
For Cisco UCS VIC 1455 and 1457 MLOM:	5.3(2.32)
Cisco UCS VIC 1385 and 1387 MLOM	4.6(2.230015)

Cisco UCS VIC Slot for SingleConnect Integration

If you are using Cisco UCS VIC for single-connect, make sure the card is inserted in one of the slots as described in the following table:

Table 14: Cisco UCS VIC Slot

Server	PCIe Slot
Cisco UCS C225 M8 Server	MLOM, 2 and 5 Note If slots 2 and 5 are occupied with GPUs, then VICs can be placed in slots 1 and 4.
Cisco UCS C245 M8 Server	MLOM, 2 and 5 Note If slots 2 and 5 are occupied with GPUs, then VICs can be placed in slots 1 and 4.
Cisco UCS C220 M7 Server	MLOM, 1, 3
Cisco UCS C240 M7 Server	MLOM, 1, 2, 4, and 5 Note If slots 2 and 5 are occupied with GPUs, then VICs can be placed in slots 1 and 4.
Cisco UCS C220 M6 Server	MLOM, 1, 3
Cisco UCS C240 M6 Server	MLOM, 1, 2, 4, and 5 Note If slots 2 and 5 are occupied with GPUs, then VICs can be placed in slots 1 and 4.
Cisco UCS C245 M6 Server	MLOM, 1, 2, 4, and 5 Note If slots 2 and 5 are occupied with GPUs, then VICs can be placed in slots 1 and 4.
Cisco UCS C220 M5 Server	MLOM, 1 For Cisco UCS C220 M5 Server servers you can use either MLOM or VIC to integrate with Cisco UCS Manager in SingleConnect or direct connect mode.

Server	PCIe Slot
Cisco UCS C240 M5 Server	MLOM, 1, 2, 4, 5 Note If slots 2 and 5 are occupied with GPUs, then VICs can be placed in slots 1 and 4. For Cisco UCS C240 M5 Server servers you can use either MLOM or VIC to integrate with Cisco UCS Manager in SingleConnect or direct connect mode. See Cisco UCS Manager Management for Mixed VIC Set-up, on page 33 for slot combination.
Cisco UCS C240 SD M5 Server	MLOM, 1, 2
Cisco UCS C480 M5 Server	1, 2
Cisco UCS C125 M5 Server	2 Cisco UCS C125 M5 Servers do not support MLOM. For Cisco UCS C125 M5 Servers, you must place the VIC card in slot 2 only.
Cisco UCS C480 M5 Server	1, 2
Cisco UCS C480 M5 ML Server	11, 12

Cabling Considerations

Refer xx for the compatible cables. (release notes link)

Requirements for Non-Cluster Setup

If you are integrating the server in a non-cluster setup, along with the Cisco UCS Manager and C-series rack mount server, you need the following components :

- A Cisco UCS system that is running Cisco UCS Manager.
- Any of the C-Series Rack-Mount Servers and corresponding Cisco IMC and UCS Manager release versions listed in [Table 12: Minimum Required Version of Cisco IMC, BIOS and Cisco UCS Manager, on page 30](#).
- One Cisco UCS VIC cards and one Cisco UCS FI. See [Cisco UCS Fabric Interconnect Server Compatibility Matrix, on page 7](#) for adapter and FI compatibility with your server.
- Refer [Recommended Cisco VIC Firmware Version, on page 30](#).
- To enable Cisco UCS Manager integration, you must have a Cisco VIC installed in the specific slot assigned in the rack server. If the VIC is not in the specific slot, integration does not work. Refer [Cisco UCS VIC Slot for SingleConnect Integration, on page 31](#).
- Refer [Cabling Considerations, on page 32](#)

Cisco UCS Manager for Mixed Cisco UCS VIC Setup

Cisco UCS Manager Management for Mixed VIC Set-up

Cisco UCS Manager does not provide full support in a setup with Cisco UCS M6 Servers and mixed VIC cards.

Table 15: Cisco UCS Manager Management

Slots	Cisco UCS Manager Management
Only MLOM.	MLOM is the default connectivity adapter.
Both MLOM and VIC adapters.	MLOM is the default connectivity adapter.
Only VIC adapter and no MLOM.	VIC adapter can be installed on slot 1 for single connect or direct connect integration.

Cisco UCS Manager Management for Mixed VIC Set-up

Cisco UCS Manager does not provide full support in a setup with Cisco UCS M5 Servers and mixed VIC cards.

Table 16: Cisco UCS Manager Management

Slots	Cisco UCS Manager Management
Only MLOM.	MLOM is the default connectivity adapter.
Both MLOM and VIC adapters.	MLOM is the default connectivity adapter.
Only VIC adapter and no MLOM.	VIC adapter can be installed on slot 1 for single connect or direct connect integration.

Cisco UCS Manager Management for Mixed VIC Set-up in C240 M5 Server

Cisco UCS Manager does not provide full support in a setup with Cisco UCS C240 M5 Server and mixed VIC cards.

Table 17: Cisco UCS Manager Management

Slots	Cisco UCS Manager Management
Both slot 1 and slot 2 are occupied. Slot 1 - Cisco VIC 1455 Slot 2 - Any Cisco VIC card or third-party adapter	Cisco UCS Manager detects only slot 2.

Slots	Cisco UCS Manager Management
Both slot 1 and slot 2 are occupied. Slot 1 - Any Cisco VIC card or third-party adapter except Cisco VIC 1455 Slot 2 - Cisco VIC 1455	Cisco UCS Manager detects both the slots.
Both slot 1 and slot 2 are occupied. Slot 1 - Any Cisco VIC card or third-party adapter except Cisco VIC 1455 Slot 2 - Any Cisco VIC card or third-party adapter	Cisco UCS Manager detects both the slots.
Only one slot is occupied. Slot 1 - Any Cisco VIC card or third-party adapter or Slot 2 - Any Cisco VIC card or third-party adapter	Cisco UCS Manager detects whichever slot is occupied.
Both slot 4 and slot 5 are occupied. Slot 4 - Cisco VIC 1455 Slot 5 - Any Cisco VIC card or third-party adapter	Cisco UCS Manager detects only slot 5.
Both slot 4 and slot 5 are occupied. Slot 4 - Any Cisco VIC card or third-party adapter except Cisco VIC 1455 Slot 5 - Cisco VIC 1455	Cisco UCS Manager detects both the slots.
Both slot 4 and slot 5 are occupied. Slot 4 - Any Cisco VIC card or third-party adapter except Cisco VIC 1455 Slot 5 - Any Cisco VIC card or third-party adapter	Cisco UCS Manager detects both the slots.
Only one slot is occupied. Slot 4 - Any Cisco VIC card or third-party adapter or Slot 5 - Any Cisco VIC card or third-party adapter	Cisco UCS Manager detects whichever slot is occupied.

Cisco UCS Manager Management for Mixed VIC Set-up in C220 M6 Server

Cisco UCS Manager does not provide full support in a setup with Cisco UCS C220 M6 Server and mixed VIC cards.

Table 18: Cisco UCS Manager Management

Slots	Cisco UCS Manager Management
Slot 1, slot 2, and slot 3 are occupied. Slot 1 - Cisco VIC 1455 or Cisco VIC 1495 Slot 2 - Any Cisco VIC card or third-party adapter Slot 3 - Any Cisco VIC card or third-Party Adapter	Cisco UCS Manager detects only slot 2.
Slot 1, slot 2, and slot 3 are occupied. Slot 1 - Any Cisco VIC card or third-party adapter except Cisco VIC 1455 or Cisco VIC 1495 Slot 2 - Cisco VIC 1455 or Cisco VIC 1495 Slot 3 - Any Cisco VIC card or third-Party Adapter except Cisco VIC 1455 or Cisco VIC 1495	Cisco UCS Manager detects all the slots.
Slot 1, slot 2, and slot 3 are occupied. Slot 1 - Any Cisco VIC card or third-party adapter except Cisco VIC 1455 or Cisco VIC 1495 Slot 2 - Any Cisco VIC card or third-party adapter Slot 3 - Any Cisco VIC card or third-Party Adapter	Cisco UCS Manager detects all the slots.
Only one slot is occupied. Slot 1 - Any Cisco VIC card or third-party adapter or Slot 2 - Any Cisco VIC card or third-party adapter or Slot 3 - Any Cisco VIC card or third-party adapter	Cisco UCS Manager detects whichever slot is occupied.
Both slot 4 and slot 5 are occupied. Slot 4 - Cisco VIC 1455 or Cisco VIC 1495 Slot 5 - Any Cisco VIC card or third-party adapter	Cisco UCS Manager detects only slot 5.
Both slot 4 and slot 5 are occupied. Slot 4 - Any Cisco VIC card or third-party adapter except Cisco VIC 1455 or Cisco VIC 1495 Slot 5 - Cisco VIC 1455 or Cisco VIC 1495	Cisco UCS Manager detects both the slots.
Both slot 4 and slot 5 are occupied. Slot 4 - Any Cisco VIC card or third-party adapter except Cisco VIC 1455 or Cisco VIC 1495 Slot 5 - Any Cisco VIC card or third-party adapter	Cisco UCS Manager detects both the slots.

Slots	Cisco UCS Manager Management
Only one slot is occupied. Slot 4 - Any Cisco VIC card or third-party adapter or Slot 5 - Any Cisco VIC card or third-party adapter	Cisco UCS Manager detects whichever slot is occupied.



Note Cisco VIC 1495 is supported only on Cisco UCS 6300 Series Fabric Interconnects.

Cisco UCS Manager Management for Mixed VIC Set-up in C240 M6 Server

Cisco UCS Manager does not provide full support in a setup with Cisco UCS C240 M6 Server and mixed VIC cards.

Table 19: Cisco UCS Manager Management

Slots	Cisco UCS Manager Management
Both slot 1 and slot 2 are occupied. Slot 1 - Cisco VIC 1455 or Cisco VIC 1495 Slot 2 - Any Cisco VIC card or third-party adapter	Cisco UCS Manager detects only slot 2.
Both slot 1 and slot 2 are occupied. Slot 1 - Any Cisco VIC card or third-party adapter except Cisco VIC 1455 or Cisco VIC 1495 Slot 2 - Cisco VIC 1455 or Cisco VIC 1495	Cisco UCS Manager detects both the slots.
Both slot 1 and slot 2 are occupied. Slot 1 - Any Cisco VIC card or third-party adapter except Cisco VIC 1455 or Cisco VIC 1495 Slot 2 - Any Cisco VIC card or third-party adapter	Cisco UCS Manager detects both the slots.
Only one slot is occupied. Slot 1 - Any Cisco VIC card or third-party adapter or Slot 2 - Any Cisco VIC card or third-party adapter	Cisco UCS Manager detects whichever slot is occupied.
Both slot 4 and slot 5 are occupied. Slot 4 - Cisco VIC 1455 or Cisco VIC 1495 Slot 5 - Any Cisco VIC card or third-party adapter	Cisco UCS Manager detects only slot 5.

Slots	Cisco UCS Manager Management
Both slot 4 and slot 5 are occupied. Slot 4 - Any Cisco VIC card or third-party adapter except Cisco VIC 1455 or Cisco VIC 1495 Slot 5 - Cisco VIC 1455 or Cisco VIC 1495	Cisco UCS Manager detects both the slots.
Both slot 4 and slot 5 are occupied. Slot 4 - Any Cisco VIC card or third-party adapter except Cisco VIC 1455 or Cisco VIC 1495 Slot 5 - Any Cisco VIC card or third-party adapter	Cisco UCS Manager detects both the slots.
Only one slot is occupied. Slot 4 - Any Cisco VIC card or third-party adapter or Slot 5 - Any Cisco VIC card or third-party adapter	Cisco UCS Manager detects whichever slot is occupied.



Note Cisco VIC 1495 is supported only on Cisco UCS 6300 Series Fabric Interconnects.

Cisco UCS Manager Management for Mixed VIC Set-up in C245 M6 Server

Cisco UCS Manager does not provide full support in a setup with Cisco UCS C245 M6 Server and mixed VIC cards.

Table 20: Cisco UCS Manager Management

Slots	Cisco UCS Manager Management
Both slot 1 and slot 2 are occupied. Slot 1 - Cisco VIC 1455 or Cisco VIC 1495 Slot 2 - Any Cisco VIC card or third-party adapter	Cisco UCS Manager detects only slot 2.
Both slot 1 and slot 2 are occupied. Slot 1 - Any Cisco VIC card or third-party adapter except Cisco VIC 1455 or Cisco VIC 1495 Slot 2 - Cisco VIC 1455 or Cisco VIC 1495	Cisco UCS Manager detects both the slots.
Both slot 1 and slot 2 are occupied. Slot 1 - Any Cisco VIC card or third-party adapter except Cisco VIC 1455 or Cisco VIC 1495 Slot 2 - Any Cisco VIC card or third-party adapter	Cisco UCS Manager detects both the slots.

Slots	Cisco UCS Manager Management
Only one slot is occupied. Slot 1 - Any Cisco VIC card or third-party adapter or Slot 2 - Any Cisco VIC card or third-party adapter	Cisco UCS Manager detects whichever slot is occupied.
Both slot 4 and slot 5 are occupied. Slot 4 - Cisco VIC 1455 or Cisco VIC 1495 Slot 5 - Any Cisco VIC card or third-party adapter	Cisco UCS Manager detects only slot 5.
Both slot 4 and slot 5 are occupied. Slot 4 - Any Cisco VIC card or third-party adapter except Cisco VIC 1455 or Cisco VIC 1495 Slot 5 - Cisco VIC 1455 or Cisco VIC 1495	Cisco UCS Manager detects both the slots.
Both slot 4 and slot 5 are occupied. Slot 4 - Any Cisco VIC card or third-party adapter except Cisco VIC 1455 or Cisco VIC 1495 Slot 5 - Any Cisco VIC card or third-party adapter	Cisco UCS Manager detects both the slots.
Only one slot is occupied. Slot 4 - Any Cisco VIC card or third-party adapter or Slot 5 - Any Cisco VIC card or third-party adapter	Cisco UCS Manager detects whichever slot is occupied.



Note Cisco VIC 1495 is supported only on Cisco UCS 6300 Series Fabric Interconnects.

Cisco UCS Manager Management for Mixed VIC Set-up in C245 M8 Server

Cisco UCS Manager does not provide full support in a setup with Cisco UCS C245 M8 Server and mixed VIC cards.

Table 21: Cisco UCS Manager Management

Slots	Cisco UCS Manager Management
Both slot 1 and slot 2 are occupied. Slot 1 - Cisco VIC 15425 or Cisco VIC 15235 Slot 2 - Any Cisco VIC card or third-party adapter	Cisco UCS Manager detects only slot 2.

Slots	Cisco UCS Manager Management
Both slot 1 and slot 2 are occupied. Slot 1 - Any Cisco VIC card or third-party adapter except Cisco VIC 15425 or Cisco VIC 15235 Slot 2 - Cisco VIC 15425 or Cisco VIC 15235	Cisco UCS Manager detects both the slots.
Both slot 1 and slot 2 are occupied. Slot 1 - Any Cisco VIC card or third-party adapter except Cisco VIC 15425 or Cisco VIC 15235 Slot 2 - Any Cisco VIC card or third-party adapter	Cisco UCS Manager detects both the slots.
Only one slot is occupied. Slot 1 - Any Cisco VIC card or third-party adapter or Slot 2 - Any Cisco VIC card or third-party adapter	Cisco UCS Manager detects whichever slot is occupied.
Both slot 4 and slot 5 are occupied. Slot 4 - Cisco VIC 15425 or Cisco VIC 15235 Slot 5 - Any Cisco VIC card or third-party adapter	Cisco UCS Manager detects only slot 5.
Both slot 4 and slot 5 are occupied. Slot 4 - Any Cisco VIC card or third-party adapter except Cisco VIC 15425 or Cisco VIC 15235 Slot 5 - Cisco VIC 15425 or Cisco VIC 15235	Cisco UCS Manager detects both the slots.
Both slot 4 and slot 5 are occupied. Slot 4 - Any Cisco VIC card or third-party adapter except Cisco VIC 15425 or Cisco VIC 15235 Slot 5 - Any Cisco VIC card or third-party adapter	Cisco UCS Manager detects both the slots.
Only one slot is occupied. Slot 4 - Any Cisco VIC card or third-party adapter or Slot 5 - Any Cisco VIC card or third-party adapter	Cisco UCS Manager detects whichever slot is occupied.

Cisco UCS Manager Management for Mixed VIC Set-up in C225 M8 Server

Cisco UCS Manager does not provide full support in a setup with Cisco UCS C225 M8 Server and mixed VIC cards.

Table 22: Cisco UCS Manager Management

Slots	Cisco UCS Manager Management
Both slot 1 and slot 2 are occupied. Slot 1 - Cisco VIC 15425 or Cisco VIC 15235 Slot 2 - Any Cisco VIC card or third-party adapter	Cisco UCS Manager detects only slot 2.
Both slot 1 and slot 2 are occupied. Slot 1 - Any Cisco VIC card or third-party adapter except Cisco VIC 15425 or Cisco VIC 15235 Slot 2 - Cisco VIC 15425 or Cisco VIC 15235	Cisco UCS Manager detects both the slots.
Both slot 1 and slot 2 are occupied. Slot 1 - Any Cisco VIC card or third-party adapter except Cisco VIC 15425 or Cisco VIC 15235 Slot 2 - Any Cisco VIC card or third-party adapter	Cisco UCS Manager detects both the slots.
Only one slot is occupied. Slot 1 - Any Cisco VIC card or third-party adapter or Slot 2 - Any Cisco VIC card or third-party adapter	Cisco UCS Manager detects whichever slot is occupied.
Both slot 4 and slot 5 are occupied. Slot 4 - Cisco VIC 15425 or Cisco VIC 15235 Slot 5 - Any Cisco VIC card or third-party adapter	Cisco UCS Manager detects only slot 5.
Both slot 4 and slot 5 are occupied. Slot 4 - Any Cisco VIC card or third-party adapter except Cisco VIC 15425 or Cisco VIC 15235 Slot 5 - Cisco VIC 15425 or Cisco VIC 15235	Cisco UCS Manager detects both the slots.
Both slot 4 and slot 5 are occupied. Slot 4 - Any Cisco VIC card or third-party adapter except Cisco VIC 15425 or Cisco VIC 15235 Slot 5 - Any Cisco VIC card or third-party adapter	Cisco UCS Manager detects both the slots.
Only one slot is occupied. Slot 4 - Any Cisco VIC card or third-party adapter or Slot 5 - Any Cisco VIC card or third-party adapter	Cisco UCS Manager detects whichever slot is occupied.

Connecting the C-Series Server with Cisco UCS Domain in Cluster Setup

Connecting the C-Series Server with Cisco UCS Domain in Cluster Setup

Before you begin



Important Ensure that Cisco IMC is set to factory default settings to integrate with Cisco UCS Manager.

Before you connect the server, ensure that the Cisco UCS VIC is installed in the correct slot for integration with Cisco UCS Manager. If the card is not installed in the correct slot, you cannot enable the single-wire management for the server.

Procedure

-
- Step 1** Install the server in the rack. See the *Install and Upgrade Guide* for the server that you are using. The install guides are available at the following url: [Install and Upgrade Guides](#).
- Step 2** Connect the path that carries both data traffic and management traffic to the FEXes:
- Connect a supported cable between the adapter card in the server and a port on the FEX that is connected to Fabric A. You can use any port on the FEX.
 - Connect a supported SFP cable between the adapter card in the server and a port on the FEX that is connected to Fabric B. You can use any port on the FEX.
- Step 3** Connect the paths from the FEXes to the FIs.
- Connect at least two supported SFP cables between FEX A and two ports on FI A. You can use any ports on FI A, but the ports must be configured as server ports.
 - Connect at least two supported SFP cables between FEX B and two ports on FI B. You can use any ports on FI B, but the ports must be configured as server ports.
 - On the FEX, you can use only the right block of eight ports for uplinks. The maximum number of uplinks is eight
 - Do not mix SFP types on an uplink. Doing so might result in a discovery failure.
 - For cabling information, see [Physical Connectivity Illustrations for SingleConnect Cluster Setup](#), on page 42.
- Step 4** Attach a power cord to each power supply in your server, and then attach the power cord to a grounded AC power outlet.
- Step 5** Reboot the server.
-

Physical Connectivity Illustrations for SingleConnect Cluster Setup

The following image shows a sample of SingleConnect physical connectivity for C-Series Rack-Mount Server with Cisco UCS Domain, Cisco UCS Manager. This image shows the cabling configuration for Cisco UCS Manager integration with a C-Series Rack-Mount Server. The paths shown in gold carry both management traffic and data traffic.

The illustrations given are only for example purpose. The equipment setup may vary depending on the server, FI, and FEX.

Figure 3: SingleConnect Cabling Configuration

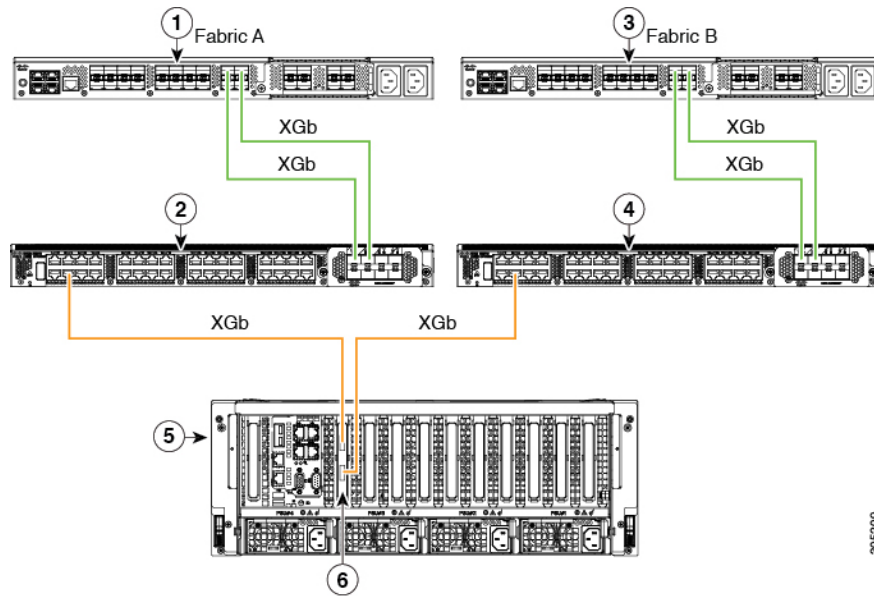
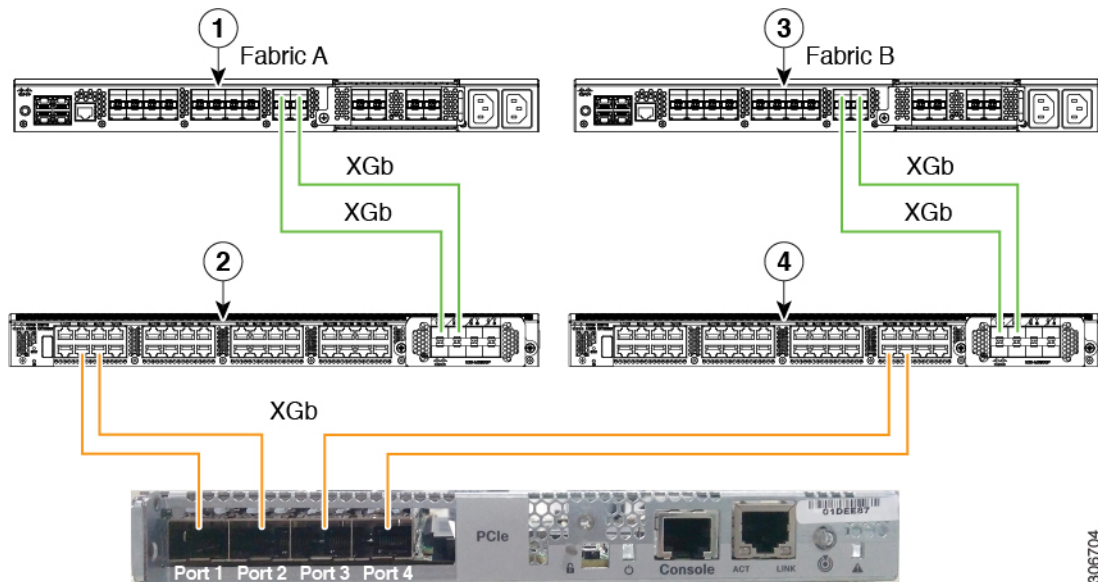

Figure 4: SingleConnect Cabling Configuration with Cisco VIC



1	Cisco UCS UCS FI (Fabric A)	4	FEX for Cisco UCS VIC
2	FEX or Cisco UCS VIC	5	C-Series Rack-Mount Server
3	Cisco UCS UCS FI (Fabric B)	6	Cisco UCS VIC in supported PCIe or MLOM slot.



Note XGb represents a Ethernet connection speed. For speed values, refer [Cisco UCS Fabric Interconnect Server Compatibility Matrix, on page 7](#). For cabling requirements, see xxx (release notes ref)

Connecting the C-Series Server with Cisco UCS Domain in Non-Cluster Setup

Connecting the C-Series Server with UCS Domain in Non-cluster Setup

To connect the C-Series Server with UCS domain, complete the same steps described in [Connecting the C-Series Server with Cisco UCS Domain in Cluster Setup, on page 41](#). Instead of connecting two FIs and two FEXes, you need to connect only one FI and one FEX.

Figure 5: Single-wire Non-Cluster Setup Example

The following illustration is an example of a non-cluster setup in single-wire management.

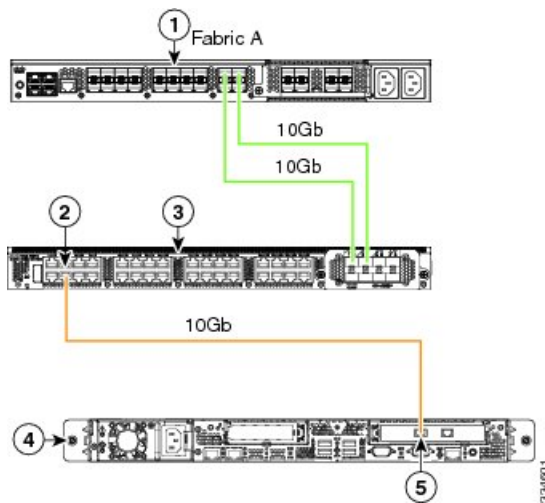

1	Cisco UCS FI	4	C-Series Rack-Mount Server
2	SingleConnect connection	5	Cisco UCS VIC adapter in supported PCIe slot
3	Cisco FEX (Fabric A)		

Cabling Considerations

Refer xx for the compatible cables. (release notes link)

Physical Connectivity Illustrations for SingleConnect Non-Cluster Setup

The following image shows a sample of SingleConnect physical connectivity for C-Series Rack-Mount Server with Cisco UCS Domain, Cisco UCS Manager. This image shows the cabling configuration for Cisco UCS Manager integration with a C-Series Rack-Mount Server. The paths shown in gold carry both management traffic and data traffic.

The illustrations given are only for example purpose. The equipment setup may vary depending on the server, FI, and FEX.

Figure 6: SingleConnect Cabling Configuration with Cisco - Single Cable

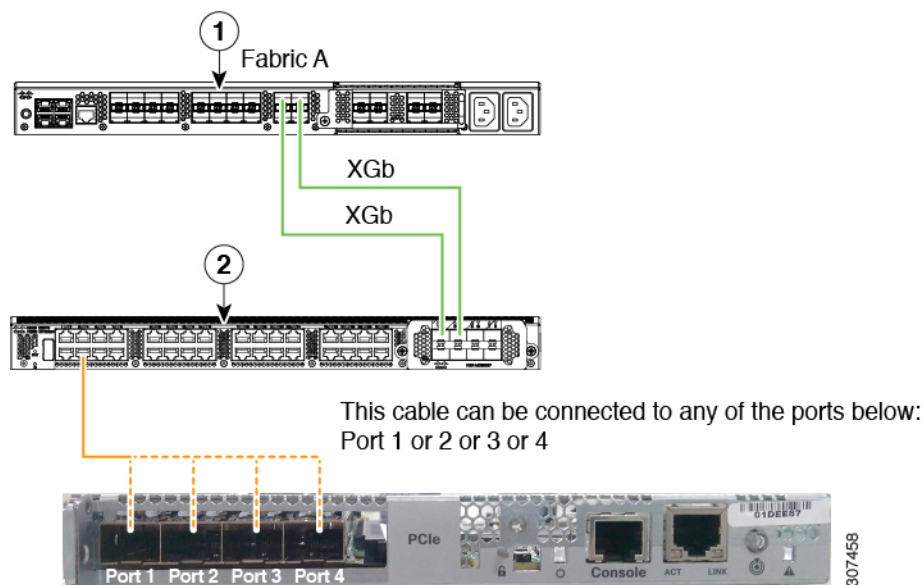
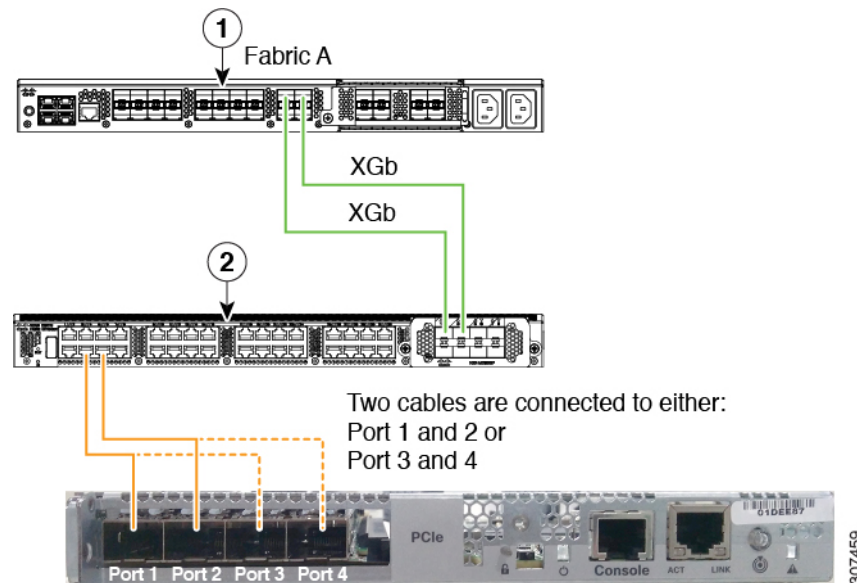

Figure 7: SingleConnect Cabling Configuration with Cisco VIC - Dual Cable



Note XGb represents a Ethernet connection speed. For speed values, refer [Cisco UCS Fabric Interconnect Server Compatibility Matrix, on page 7](#). For cabling requirements, see xxx (release notes ref)

Managing the Rack-Mount Server in Cisco UCS Manager after Integration

You can manage and monitor all rack-mount servers that have been integrated with a Cisco UCS domain through Cisco UCS Manager. After the integration, you can perform all rack-mount server management tasks only through the service profiles from Cisco UCS Manager GUI or Cisco UCS Manager CLI. The C-Series Rack-Mount Server Cisco IMC is not accessible when you start managing the server with Cisco UCS Manager.

Cisco UCS Manager provides information, errors, and faults for each rack-mount server that was discovered.

For more information on managing C-Series Rack-Mount Servers from Cisco UCS Manager, see the chapter on Managing Rack-Mount Servers in your release specific [Cisco UCS Manager Configuration Guide](#).

Reverting a Server From Cisco UCS Domain Mode to Standalone Mode

When you manage a Cisco UCS C-Series server with Cisco UCS Manager software, a UCS Manager service profile is associated with the server. If you want to revert a C-Series server to standalone mode (so that it can be managed by Cisco IMC software), you must do the following actions in UCS Manager:

Procedure

-
- Step 1** Disassociate the UCS Manager service profile from the server.
- Step 2** Remove the connections from the adapter.
- Step 3** Manually power on the server.
- Step 4** Connect the front panel KVM connection.
- Step 5** Press **F8** during the boot up.
- Step 6** Reset Cisco IMC to factory defaults or stand-alone mode.

Caution If you do not disassociate the service profile from the server, MAC and WWN numbers assigned by Cisco UCS Manager might be kept by the server. This can cause numbering duplication and conflicts with other servers that are managed by Cisco UCS Manager. Also, if you revert a server to standalone mode without disassociating the service profile, any LSI RAID controller may not show as a bootable device in the standalone server, preventing local booting.

Special Considerations for Integrated Servers

When you connect the C-Series servers in Cisco UCS system, make sure to review the following information:

- [FEX Considerations, on page 46](#)
- [Cisco VIC 1467 and VIC 15428 Connectivity, on page 46](#)

FEX Considerations

Re-acknowledge Attached Servers After a FEX Is Decommissioned/Recommissioned

Whenever you decommission or recommission a Cisco UCS FEX, all the servers that are connected to that FEX must be re-acknowledged in UCS Manager.

Cisco VIC 1455 and 1457 Connectivity

For cluster setup, connect port 1 and 2 to one FEX. Connect port 3 and 4 to another FEX. For non-cluster setup, connect either port 1 and 2 or port 3 and 4 to the FEX.

Cisco VIC 1467 and VIC 15428 Connectivity

For cluster setup, connect port 1 and 2 to one FEX. Connect port 3 and 4 to another FEX. For non-cluster setup, connect either port 1 and 2 or port 3 and 4 to the FEX.



CHAPTER 3

Configuring Direct Connect

This chapter includes the following sections:

- [Direct Connect Mode, on page 47](#)
- [Management Connection Policy and Connection Mode, on page 48](#)
- [Requirements for Direct Connect Mode Integration with Cisco UCS Manager, on page 48](#)
- [Cisco UCS Manager for Mixed Cisco UCS VIC Setup, on page 51](#)
- [Connecting the C-Series Server with Cisco UCS Domain in Cluster Setup, on page 60](#)
- [Connecting the C-Series Server with Cisco UCS Domain in Non-Cluster Setup, on page 63](#)
- [Migrating C-Series Servers from SingleConnect to Direct Connect Mode, on page 64](#)
- [Migrating C-Series Servers from Dual-wire Management to Direct Connect Mode, on page 65](#)
- [Managing the Rack-Mount Server in Cisco UCS Manager after Integration, on page 66](#)
- [Reverting a Server From Cisco UCS Domain Mode to Standalone Mode, on page 66](#)
- [Special Considerations for Integrated Servers, on page 67](#)

Direct Connect Mode

Beginning with release 3.1, Cisco UCS Manager supports an option to connect the C-Series Rack-Mount Server directly to the Fabric Interconnects. You do not need the Fabric Extenders. This option enables Cisco UCS Manager to manage the C-Series Rack-Mount Servers using a single cable for both management traffic and data traffic.



Note After connecting the server with the FI, when the server is discovered, make sure to update the C-Series software bundle available for Cisco UCS Manager, release 3.1 or later.

VIF Scalability

For the maximum number of virtual interfaces allowed on each adapter in the server that is directly connected to the Fabric Interconnect, see

[Cisco UCS Configuration Limits for Cisco UCS Manager Guide](#)

Management Connection Policy and Connection Mode

When establishing physical connections for the C-Series Rack-Mount Server in the Cisco UCS Domain, you must specify the connection mode and management policy in Cisco UCS Manager GUI or Cisco UCS Manager CLI. The management policy is global to all connected C-Series Rack-Mount Servers. The connection mode determines the rack server discovery in Cisco UCS Manager.

You can specify either one of the following connection policies for the rack servers:

- **Auto Acknowledged:** This is the recommended and default connection mode for the C-Series Rack-Mount Server. If the connection mode is auto-acknowledged, immediately after establishing the physical connection, Cisco UCS Manager discovers the rack server and starts managing the server based on the specified management policy.
- **User Acknowledged:** If the connection mode is user-acknowledged, after establishing the physical connection, you must manually acknowledge the connection and specify the connection mode in the Cisco UCS Manager GUI or Cisco UCS Manager CLI to begin the discovery. Cisco UCS Manager does not begin the C-Series Rack-Mount Server discovery until you specify the connection mode. See [Manually Acknowledging Connection Mode - GUI, on page 28](#) or [Manually Acknowledging Connection Mode - CLI, on page 28](#) for detailed procedure.



Note When rack servers are discovered and are managed by Cisco UCS Manager, if you want to change the existing connection mode for one C-Series Rack-Mount Server, you have to decommission the server, re-commission it and specify the new connection mode. Only then Cisco UCS Manager can discover the server in the new connection mode.

Requirements for Direct Connect Mode Integration with Cisco UCS Manager

Requirements for Cluster Setup

Requirements for Cluster Setup

You must have the following items to create a direct connect integration for C-Series Rack-Mount Server with Cisco UCS Manager in cluster setup:

- A Cisco UCS system that is running Cisco UCS Manager.
- Any of the C-Series Rack-Mount Servers and corresponding Cisco IMC and UCS Manager release versions listed in [#unique_48 unique_48_Connect_42_d23e63](#).
- Two Cisco UCS VIC cards and two Cisco UCS FIs. See [Cisco UCS Fabric Interconnect Server Compatibility Matrix, on page 7](#) for adapter and FI compatibility with your server. To enable SingleConnect for the Cisco UCS Manager integration, you must have a Cisco VIC installed in the specific slot assigned for SingleConnect in the rack server. If the VIC is not in the specific slot, SingleConnect does not work.

Minimum Required Version of Cisco IMC, BIOS and Cisco UCS Manager for DirectConnect Integration

Table 23: Minimum Required Version of Cisco IMC, BIOS and Cisco UCS Manager

Server	Cisco IMC	Cisco IMC BIOS	Cisco UCS Manager	UCS Manager (BIOS)
Cisco UCS C225 M8 Server	4.3(5.240021)	435a0090241155.gbin	4.3(5a)	C225M8.4.3.5a.0.0904241155.gbin
Cisco UCS C245 M8 Server	4.3(4.241014)	C245M8.4.3.4a.0.0520240849	4.3(4b)	ucs-c245-m8-bios.C245M8.4.3.4a.0.0520240849.bin
Cisco UCS C240 M7 Server	4.3.1.230097	C240M7.4.3.1a.0	4.3(2b)	ucs-c240-m7-bios.C240M7.4.3.2a.0.0710230213.bin
Cisco UCS C220 M7 Server	4.3.1.230097	C220M7.4.3.1a.0	4.3(2b)	ucs-c220-m7-bios.C220M7.4.3.2a.0.0710230213.bin
Cisco UCS C220 M6 Server	4.2(1)	4.2(1)	4.2(1)	4.2(1)
Cisco UCS C240 M6 Server	4.2(1)	4.2(1)	4.2(1)	4.2(1)
Cisco UCS C220 M5 Server	3.1.1d	3.1.1i.0	3.2(1d)	3.1.1i.0
Cisco UCS C245 M6 Server	4.2(1)	4.2(1)	4.2(1)	4.2(1)
Cisco UCS C240 M5 Server	3.1.1d	3.1.1h.0	3.2(1d)	3.1.1h.0
Cisco UCS C480 M5 Server	3.1(2b)	3.1.2a.0	3.2(2b)	3.1.2a.0
Cisco UCS C480 M5 Server	3.1(2b)	3.1.2a.0	3.2(2b)	3.1.2a.0
Cisco UCS C125 M5 Server	4.0(1a)	4.0(1a)	4.0(1a)	4.0(1a)
Cisco UCS C480 M5 ML Server	4.0(2a)	4.0(2a)	4.0(2a)	4.0(2a)
Cisco UCS C240 SD M5 Server	4.1(2)	4.1(2)	4.1(2)	4.1(2)

Recommended Cisco VIC Firmware Version

Table 24: Recommended Cisco VIC Firmware Version

Server	VIC Firmware Version
Cisco UCS VIC 15238	5.3(2.32)
Cisco UCS VIC 15235	5.3(2.32)-48
Cisco UCS VIC 15425	5.3(2.32)-48
For Cisco UCS VIC 15428 MLOM	5.3(2.32)-48
Cisco UCS VIC 1495	5.3(2.32)
For Cisco UCS VIC 1467 and 1477 MLOM:	5.3(2.32)
For Cisco UCS VIC 1455 and 1457 MLOM:	5.3(2.32)
Cisco UCS VIC 1385 and 1387 MLOM	4.6(2.230015)

Recommended Cisco VIC Slot

Table 25: Cisco UCS VIC Slot

Server	PCIe Slot
Cisco UCS C225 M8 Server	MLOM, 2 and 5 Note If slots 2 and 5 are occupied with GPUs, then VICs can be placed in slots 1 and 4.
Cisco UCS C245 M8 Server	MLOM, 2 and 5 Note If slots 2 and 5 are occupied with GPUs, then VICs can be placed in slots 1 and 4.
Cisco UCS C220 M7 Server	MLOM, 1, 3
Cisco UCS C240 M7 Server	MLOM, 1, 2, 4, and 5 Note If slots 2 and 5 are occupied with GPUs, then VICs can be placed in slots 1 and 4.
Cisco UCS C220 M6 Server	MLOM, 1, 3
Cisco UCS C240 M6 Server	MLOM, 1, 2, 4, and 5 Note If slots 2 and 5 are occupied with GPUs, then VICs can be placed in slots 1 and 4.
Cisco UCS C245 M6 Server	MLOM, 1, 2, 4, and 5 Note If slots 2 and 5 are occupied with GPUs, then VICs can be placed in slots 1 and 4.
Cisco UCS C220 M5 Server	MLOM, 1 For Cisco UCS C220 M5 Server servers you can use either MLOM or VIC to integrate with Cisco UCS Manager in SingleConnect or direct connect mode.
Cisco UCS C240 M5 Server	MLOM, 1, 2, 4, 5 Note If slots 2 and 5 are occupied with GPUs, then VICs can be placed in slots 1 and 4. For Cisco UCS C240 M5 Server servers you can use either MLOM or VIC to integrate with Cisco UCS Manager in SingleConnect or direct connect mode. See Cisco UCS Manager Management for Mixed VIC Set-up, on page 33 for slot combination.
Cisco UCS C240 SD M5 Server	MLOM, 1, 2

Server	PCIe Slot
Cisco UCS C480 M5 Server	1, 2
Cisco UCS C125 M5 Server	2 Cisco UCS C125 M5 Servers do not support MLOM. For Cisco UCS C125 M5 Servers, you must place the VIC card in slot 2 only.
Cisco UCS C480 M5 Server	1, 2
Cisco UCS C480 M5 ML Server	11, 12

Cabling Considerations

Refer xx for the compatible cables. (release notes link)

Non-Cluster Setup

If you are integrating the server in a non-cluster setup, along with the Cisco UCS Manager and C-series rack mount server, you need the following components :

- A Cisco UCS system that is running Cisco UCS Manager.
- Any of the C-Series Rack-Mount Servers and corresponding Cisco IMC and UCS Manager release versions listed in [Table 12: Minimum Required Version of Cisco IMC, BIOS and Cisco UCS Manager, on page 30](#).
- One Cisco UCS VIC cards and one Cisco UCS FI. See [Cisco UCS Fabric Interconnect Server Compatibility Matrix, on page 7](#) for adapter and FI compatibility with your server.
- Refer [Recommended Cisco VIC Firmware Version, on page 30](#).
- To enable Cisco UCS Manager integration, you must have a Cisco VIC installed in the specific slot assigned in the rack server. If the VIC is not in the specific slot, integration does not work. Refer [Cisco UCS VIC Slot for SingleConnect Integration, on page 31](#).
- Refer [Cabling Considerations, on page 32](#)

Cisco UCS Manager for Mixed Cisco UCS VIC Setup

Cisco UCS Manager Management for Mixed VIC Set-up

Cisco UCS Manager does not provide full support in a setup with Cisco UCS M6 Servers and mixed VIC cards.

Table 26: Cisco UCS Manager Management

Slots	Cisco UCS Manager Management
Only MLOM.	MLOM is the default connectivity adapter.
Both MLOM and VIC adapters.	MLOM is the default connectivity adapter.
Only VIC adapter and no MLOM.	VIC adapter can be installed on slot 1 for single connect or direct connect integration.

Cisco UCS Manager Management for Mixed VIC Set-up

Cisco UCS Manager does not provide full support in a setup with Cisco UCS M5 Servers and mixed VIC cards.

Table 27: Cisco UCS Manager Management

Slots	Cisco UCS Manager Management
Only MLOM.	MLOM is the default connectivity adapter.
Both MLOM and VIC adapters.	MLOM is the default connectivity adapter.
Only VIC adapter and no MLOM.	VIC adapter can be installed on slot 1 for single connect or direct connect integration.

Cisco UCS Manager Management for Mixed VIC Set-up in C240 M5 Server

Cisco UCS Manager does not provide full support in a setup with Cisco UCS C240 M5 Server and mixed VIC cards.

Table 28: Cisco UCS Manager Management

Slots	Cisco UCS Manager Management
Both slot 1 and slot 2 are occupied. Slot 1 - Cisco VIC 1455 Slot 2 - Any Cisco VIC card or third-party adapter	Cisco UCS Manager detects only slot 2.
Both slot 1 and slot 2 are occupied. Slot 1 - Any Cisco VIC card or third-party adapter except Cisco VIC 1455 Slot 2 - Cisco VIC 1455	Cisco UCS Manager detects both the slots.

Slots	Cisco UCS Manager Management
Both slot 1 and slot 2 are occupied. Slot 1 - Any Cisco VIC card or third-party adapter except Cisco VIC 1455 Slot 2 - Any Cisco VIC card or third-party adapter	Cisco UCS Manager detects both the slots.
Only one slot is occupied. Slot 1 - Any Cisco VIC card or third-party adapter or Slot 2 - Any Cisco VIC card or third-party adapter	Cisco UCS Manager detects whichever slot is occupied.
Both slot 4 and slot 5 are occupied. Slot 4 - Cisco VIC 1455 Slot 5 - Any Cisco VIC card or third-party adapter	Cisco UCS Manager detects only slot 5.
Both slot 4 and slot 5 are occupied. Slot 4 - Any Cisco VIC card or third-party adapter except Cisco VIC 1455 Slot 5 - Cisco VIC 1455	Cisco UCS Manager detects both the slots.
Both slot 4 and slot 5 are occupied. Slot 4 - Any Cisco VIC card or third-party adapter except Cisco VIC 1455 Slot 5 - Any Cisco VIC card or third-party adapter	Cisco UCS Manager detects both the slots.
Only one slot is occupied. Slot 4 - Any Cisco VIC card or third-party adapter or Slot 5 - Any Cisco VIC card or third-party adapter	Cisco UCS Manager detects whichever slot is occupied.

Cisco UCS Manager Management for Mixed VIC Set-up in C220 M6 Server

Cisco UCS Manager does not provide full support in a setup with Cisco UCS C220 M6 Server and mixed VIC cards.

Table 29: Cisco UCS Manager Management

Slots	Cisco UCS Manager Management
Slot 1, slot 2, and slot 3 are occupied. Slot 1 - Cisco VIC 1455 or Cisco VIC 1495 Slot 2 - Any Cisco VIC card or third-party adapter Slot 3 - Any Cisco VIC card or third-Party Adapter	Cisco UCS Manager detects only slot 2.
Slot 1, slot 2, and slot 3 are occupied. Slot 1 - Any Cisco VIC card or third-party adapter except Cisco VIC 1455 or Cisco VIC 1495 Slot 2 - Cisco VIC 1455 or Cisco VIC 1495 Slot 3 - Any Cisco VIC card or third-Party Adapter except Cisco VIC 1455 or Cisco VIC 1495	Cisco UCS Manager detects all the slots.
Slot 1, slot 2, and slot 3 are occupied. Slot 1 - Any Cisco VIC card or third-party adapter except Cisco VIC 1455 or Cisco VIC 1495 Slot 2 - Any Cisco VIC card or third-party adapter Slot 3 - Any Cisco VIC card or third-Party Adapter	Cisco UCS Manager detects all the slots.
Only one slot is occupied. Slot 1 - Any Cisco VIC card or third-party adapter or Slot 2 - Any Cisco VIC card or third-party adapter or Slot 3 - Any Cisco VIC card or third-party adapter	Cisco UCS Manager detects whichever slot is occupied.
Both slot 4 and slot 5 are occupied. Slot 4 - Cisco VIC 1455 or Cisco VIC 1495 Slot 5 - Any Cisco VIC card or third-party adapter	Cisco UCS Manager detects only slot 5.
Both slot 4 and slot 5 are occupied. Slot 4 - Any Cisco VIC card or third-party adapter except Cisco VIC 1455 or Cisco VIC 1495 Slot 5 - Cisco VIC 1455 or Cisco VIC 1495	Cisco UCS Manager detects both the slots.
Both slot 4 and slot 5 are occupied. Slot 4 - Any Cisco VIC card or third-party adapter except Cisco VIC 1455 or Cisco VIC 1495 Slot 5 - Any Cisco VIC card or third-party adapter	Cisco UCS Manager detects both the slots.

Slots	Cisco UCS Manager Management
Only one slot is occupied. Slot 4 - Any Cisco VIC card or third-party adapter or Slot 5 - Any Cisco VIC card or third-party adapter	Cisco UCS Manager detects whichever slot is occupied.



Note Cisco VIC 1495 is supported only on Cisco UCS 6300 Series Fabric Interconnects.

Cisco UCS Manager Management for Mixed VIC Set-up in C240 M6 Server

Cisco UCS Manager does not provide full support in a setup with Cisco UCS C240 M6 Server and mixed VIC cards.

Table 30: Cisco UCS Manager Management

Slots	Cisco UCS Manager Management
Both slot 1 and slot 2 are occupied. Slot 1 - Cisco VIC 1455 or Cisco VIC 1495 Slot 2 - Any Cisco VIC card or third-party adapter	Cisco UCS Manager detects only slot 2.
Both slot 1 and slot 2 are occupied. Slot 1 - Any Cisco VIC card or third-party adapter except Cisco VIC 1455 or Cisco VIC 1495 Slot 2 - Cisco VIC 1455 or Cisco VIC 1495	Cisco UCS Manager detects both the slots.
Both slot 1 and slot 2 are occupied. Slot 1 - Any Cisco VIC card or third-party adapter except Cisco VIC 1455 or Cisco VIC 1495 Slot 2 - Any Cisco VIC card or third-party adapter	Cisco UCS Manager detects both the slots.
Only one slot is occupied. Slot 1 - Any Cisco VIC card or third-party adapter or Slot 2 - Any Cisco VIC card or third-party adapter	Cisco UCS Manager detects whichever slot is occupied.
Both slot 4 and slot 5 are occupied. Slot 4 - Cisco VIC 1455 or Cisco VIC 1495 Slot 5 - Any Cisco VIC card or third-party adapter	Cisco UCS Manager detects only slot 5.

Slots	Cisco UCS Manager Management
Both slot 4 and slot 5 are occupied. Slot 4 - Any Cisco VIC card or third-party adapter except Cisco VIC 1455 or Cisco VIC 1495 Slot 5 - Cisco VIC 1455 or Cisco VIC 1495	Cisco UCS Manager detects both the slots.
Both slot 4 and slot 5 are occupied. Slot 4 - Any Cisco VIC card or third-party adapter except Cisco VIC 1455 or Cisco VIC 1495 Slot 5 - Any Cisco VIC card or third-party adapter	Cisco UCS Manager detects both the slots.
Only one slot is occupied. Slot 4 - Any Cisco VIC card or third-party adapter or Slot 5 - Any Cisco VIC card or third-party adapter	Cisco UCS Manager detects whichever slot is occupied.



Note Cisco VIC 1495 is supported only on Cisco UCS 6300 Series Fabric Interconnects.

Cisco UCS Manager Management for Mixed VIC Set-up in C245 M6 Server

Cisco UCS Manager does not provide full support in a setup with Cisco UCS C245 M6 Server and mixed VIC cards.

Table 31: Cisco UCS Manager Management

Slots	Cisco UCS Manager Management
Both slot 1 and slot 2 are occupied. Slot 1 - Cisco VIC 1455 or Cisco VIC 1495 Slot 2 - Any Cisco VIC card or third-party adapter	Cisco UCS Manager detects only slot 2.
Both slot 1 and slot 2 are occupied. Slot 1 - Any Cisco VIC card or third-party adapter except Cisco VIC 1455 or Cisco VIC 1495 Slot 2 - Cisco VIC 1455 or Cisco VIC 1495	Cisco UCS Manager detects both the slots.
Both slot 1 and slot 2 are occupied. Slot 1 - Any Cisco VIC card or third-party adapter except Cisco VIC 1455 or Cisco VIC 1495 Slot 2 - Any Cisco VIC card or third-party adapter	Cisco UCS Manager detects both the slots.

Slots	Cisco UCS Manager Management
Only one slot is occupied. Slot 1 - Any Cisco VIC card or third-party adapter or Slot 2 - Any Cisco VIC card or third-party adapter	Cisco UCS Manager detects whichever slot is occupied.
Both slot 4 and slot 5 are occupied. Slot 4 - Cisco VIC 1455 or Cisco VIC 1495 Slot 5 - Any Cisco VIC card or third-party adapter	Cisco UCS Manager detects only slot 5.
Both slot 4 and slot 5 are occupied. Slot 4 - Any Cisco VIC card or third-party adapter except Cisco VIC 1455 or Cisco VIC 1495 Slot 5 - Cisco VIC 1455 or Cisco VIC 1495	Cisco UCS Manager detects both the slots.
Both slot 4 and slot 5 are occupied. Slot 4 - Any Cisco VIC card or third-party adapter except Cisco VIC 1455 or Cisco VIC 1495 Slot 5 - Any Cisco VIC card or third-party adapter	Cisco UCS Manager detects both the slots.
Only one slot is occupied. Slot 4 - Any Cisco VIC card or third-party adapter or Slot 5 - Any Cisco VIC card or third-party adapter	Cisco UCS Manager detects whichever slot is occupied.



Note Cisco VIC 1495 is supported only on Cisco UCS 6300 Series Fabric Interconnects.

Cisco UCS Manager Management for Mixed VIC Set-up in C245 M8 Server

Cisco UCS Manager does not provide full support in a setup with Cisco UCS C245 M8 Server and mixed VIC cards.

Table 32: Cisco UCS Manager Management

Slots	Cisco UCS Manager Management
Both slot 1 and slot 2 are occupied. Slot 1 - Cisco VIC 15425 or Cisco VIC 15235 Slot 2 - Any Cisco VIC card or third-party adapter	Cisco UCS Manager detects only slot 2.

Slots	Cisco UCS Manager Management
Both slot 1 and slot 2 are occupied. Slot 1 - Any Cisco VIC card or third-party adapter except Cisco VIC 15425 or Cisco VIC 15235 Slot 2 - Cisco VIC 15425 or Cisco VIC 15235	Cisco UCS Manager detects both the slots.
Both slot 1 and slot 2 are occupied. Slot 1 - Any Cisco VIC card or third-party adapter except Cisco VIC 15425 or Cisco VIC 15235 Slot 2 - Any Cisco VIC card or third-party adapter	Cisco UCS Manager detects both the slots.
Only one slot is occupied. Slot 1 - Any Cisco VIC card or third-party adapter or Slot 2 - Any Cisco VIC card or third-party adapter	Cisco UCS Manager detects whichever slot is occupied.
Both slot 4 and slot 5 are occupied. Slot 4 - Cisco VIC 15425 or Cisco VIC 15235 Slot 5 - Any Cisco VIC card or third-party adapter	Cisco UCS Manager detects only slot 5.
Both slot 4 and slot 5 are occupied. Slot 4 - Any Cisco VIC card or third-party adapter except Cisco VIC 15425 or Cisco VIC 15235 Slot 5 - Cisco VIC 15425 or Cisco VIC 15235	Cisco UCS Manager detects both the slots.
Both slot 4 and slot 5 are occupied. Slot 4 - Any Cisco VIC card or third-party adapter except Cisco VIC 15425 or Cisco VIC 15235 Slot 5 - Any Cisco VIC card or third-party adapter	Cisco UCS Manager detects both the slots.
Only one slot is occupied. Slot 4 - Any Cisco VIC card or third-party adapter or Slot 5 - Any Cisco VIC card or third-party adapter	Cisco UCS Manager detects whichever slot is occupied.

Cisco UCS Manager Management for Mixed VIC Set-up in C225 M8 Server

Cisco UCS Manager does not provide full support in a setup with Cisco UCS C225 M8 Server and mixed VIC cards.

Table 33: Cisco UCS Manager Management

Slots	Cisco UCS Manager Management
Both slot 1 and slot 2 are occupied. Slot 1 - Cisco VIC 15425 or Cisco VIC 15235 Slot 2 - Any Cisco VIC card or third-party adapter	Cisco UCS Manager detects only slot 2.
Both slot 1 and slot 2 are occupied. Slot 1 - Any Cisco VIC card or third-party adapter except Cisco VIC 15425 or Cisco VIC 15235 Slot 2 - Cisco VIC 15425 or Cisco VIC 15235	Cisco UCS Manager detects both the slots.
Both slot 1 and slot 2 are occupied. Slot 1 - Any Cisco VIC card or third-party adapter except Cisco VIC 15425 or Cisco VIC 15235 Slot 2 - Any Cisco VIC card or third-party adapter	Cisco UCS Manager detects both the slots.
Only one slot is occupied. Slot 1 - Any Cisco VIC card or third-party adapter or Slot 2 - Any Cisco VIC card or third-party adapter	Cisco UCS Manager detects whichever slot is occupied.
Both slot 4 and slot 5 are occupied. Slot 4 - Cisco VIC 15425 or Cisco VIC 15235 Slot 5 - Any Cisco VIC card or third-party adapter	Cisco UCS Manager detects only slot 5.
Both slot 4 and slot 5 are occupied. Slot 4 - Any Cisco VIC card or third-party adapter except Cisco VIC 15425 or Cisco VIC 15235 Slot 5 - Cisco VIC 15425 or Cisco VIC 15235	Cisco UCS Manager detects both the slots.
Both slot 4 and slot 5 are occupied. Slot 4 - Any Cisco VIC card or third-party adapter except Cisco VIC 15425 or Cisco VIC 15235 Slot 5 - Any Cisco VIC card or third-party adapter	Cisco UCS Manager detects both the slots.
Only one slot is occupied. Slot 4 - Any Cisco VIC card or third-party adapter or Slot 5 - Any Cisco VIC card or third-party adapter	Cisco UCS Manager detects whichever slot is occupied.

Connecting the C-Series Server with Cisco UCS Domain in Cluster Setup

Connecting the C-Series Server with Cisco UCS Domain in Cluster Setup

Before you begin



Important Make sure the server Cisco IMC is set to factory default settings to integrate with Cisco UCS Manager.

- Make sure the FI ports are configured as server ports. If they are not, reconfigure the ports as server ports using the Cisco UCS Manager GUI.
- Before you connect the server, make sure the Cisco UCS VIC is installed in the correct slot for integration with Cisco UCS Manager. If the card is not installed in the correct slot, you cannot enable the direct connect management for the server.

Procedure

Step 1 Install the server in the rack. See the *Install and Upgrade Guide* for the server that you are using. The install guides are available at the following url: [Install and Upgrade Guides](#).

Step 2 Configure the server ports on the FI.

Step 3 Connect the paths from Cisco UCS VIC adapter to the server ports on the FIs.

- Connect one supported SFP cable between the server and one port on FI A. You can use any port on FI A, but the port must be enabled for server traffic.

Make sure to connect one cable from the VIC to the FI for one card. You cannot connect both ports in the same FI.

- Connect one supported SFP cable between the server and one port on FI B. You can use any port on FI B, but the port must be enabled for server traffic.

- Note**
- Do not mix SFP types on an uplink. If you do, you will get `Discovery Failed` errors.
 - For cabling information, see [Physical Connectivity Illustrations for Direct Connect Mode Cluster Setup, on page 61](#).

Step 4 Attach a power cord to each power supply in your server, and then attach the power cord to a grounded AC power outlet.

Server discovery begins when power is applied.

Physical Connectivity Illustrations for Direct Connect Mode Cluster Setup

The following images shows a sample of direct connect mode physical connectivity for C-Series Rack-Mount Server with Cisco UCS Domain, Cisco UCS Manager, release 3.1 or later. This image shows the cabling configuration for Cisco UCS Manager integration with a C-Series Rack-Mount Server. The paths shown in gold carry both management traffic and data traffic.

The illustrations given are only for example purpose. The equipment setup may vary depending on the server, VIC, and FI.

Figure 8: Direct Connect Cabling Configuration

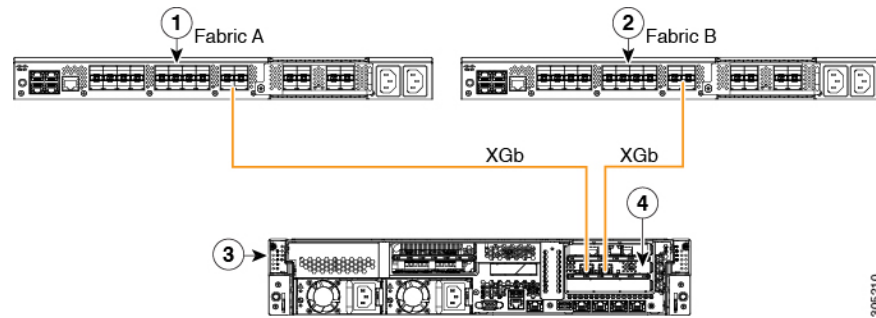

Cisco IMC on the C-Series Rack-Mount Server uses the first adapter for management and data connectivity and a second adapter only for data connectivity. Every virtual interface on the rack server needs to be connected to both Fabric Interconnect adapters. Different configurations require specific setup.

This image shows the cabling configuration for Cisco UCS Manager integration on C-Series Rack-Mount Server with dual Cisco VIC adapters. The first adapter can be configured as management only and the second adapter can be configured as data traffic only. The gold color path carries management and the red color path carries data traffic.

Different servers require different slot locations for the management. Consult the appropriate C-Series Rack Server spec sheet to locate the slot that has Network Communications Services Interface protocol support (NCSI) and use as the management.

The illustrations given are only for example purpose. The equipment setup may vary depending on the server, VIC, and FI.

Figure 9: Direct Connect Cabling Configuration for Dual Adapter

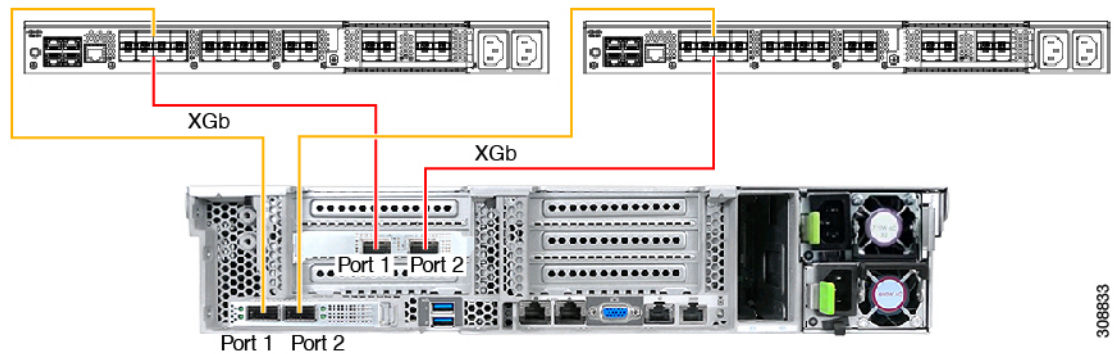

Figure 10: Direct Connect Cabling Configuration with Cisco VIC 1455 (4-Port Linking)

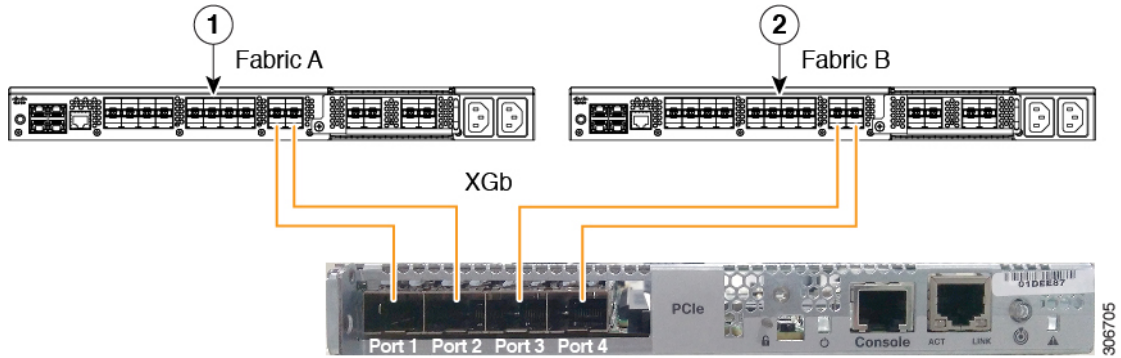
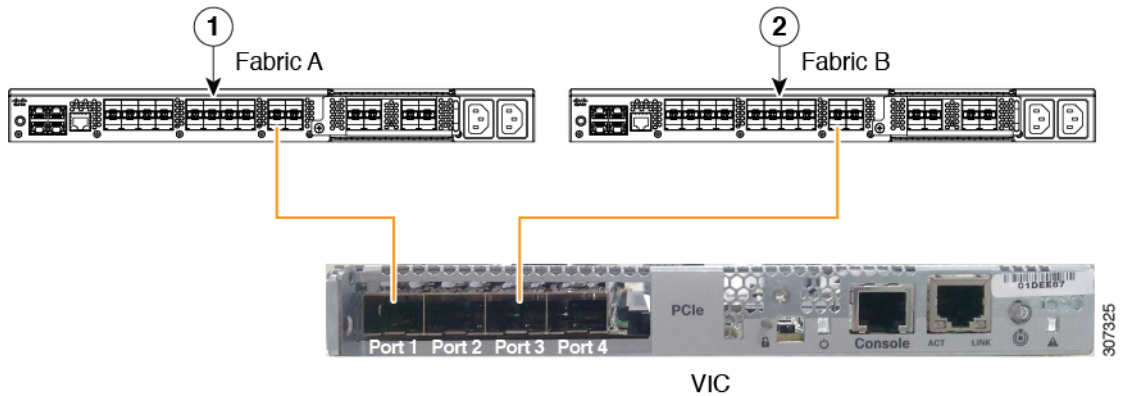

Figure 11: Direct Connect Cabling Configuration with Cisco VIC 1455 (2-Port Linking)



1	Cisco UCS UCS FI (Fabric A)	3	C-Series Rack-Mount Server
2	Cisco UCS UCS FI (Fabric B)	4	Cisco UCS VIC in supported PCIe slot



Note Ports 1 and 3 are used because the connections between ports 1 and 2 (also 3 and 4) form an internal port-channel.



Caution Do not connect port 1 to Fabric Interconnect A and port 2 to Fabric Interconnect B. Use ports 1 and 3 only. Using ports 1 and 2 results in discovery and configuration failures.



Note XGb represents a Ethernet connection speed. For speed values, refer [Cisco UCS Fabric Interconnect Server Compatibility Matrix, on page 7](#). For cabling requirements, see xxx (release notes ref)

Connecting the C-Series Server with Cisco UCS Domain in Non-Cluster Setup

Connecting the C-Series Server with UCS Domain in Non-Cluster Setup

Procedure

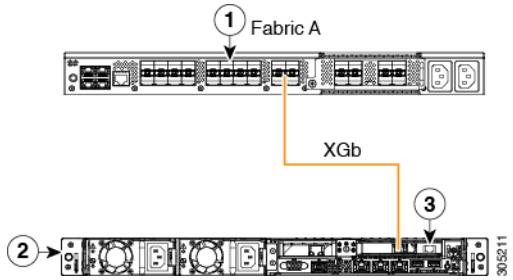
	Command or Action	Purpose				
<p>Step 1</p>	<p>To connect the C-Series server with a UCS domain in a non-cluster setup, complete the same steps described in Connecting the C-Series Server with Cisco UCS Domain in Cluster Setup, on page 60. Instead of using two FIs to connect two cables as in cluster setup, you need to connect only one FI and one cable to the adapter.</p>	<p>Figure 12: Physical Connectivity Illustration Example for Direct Connect Mode Non-Cluster Setup</p> <p>The following image show the cabling configuration for Cisco UCS Manager integration with the server. The path shown in gold carry both management and data traffic.</p>  <table border="1" data-bbox="901 1140 1528 1318"> <tr> <td data-bbox="901 1140 1230 1230">Cisco UCS FI (Fabric A)</td> <td data-bbox="1234 1140 1528 1230">2 C-Series Rack-Mount Server</td> </tr> <tr> <td data-bbox="901 1234 1230 1318"></td> <td data-bbox="1234 1234 1528 1318">3 Cisco VIC in supported PCIe slot.</td> </tr> </table> <p>XGb represents a Ethernet connection speed. For speed values, refer Cisco UCS Fabric Interconnect Server Compatibility Matrix, on page 7. For cabling requirements, see xxx (release notes ref)</p>	Cisco UCS FI (Fabric A)	2 C-Series Rack-Mount Server		3 Cisco VIC in supported PCIe slot.
Cisco UCS FI (Fabric A)	2 C-Series Rack-Mount Server					
	3 Cisco VIC in supported PCIe slot.					

Physical Connectivity Illustrations for Direct Connect Mode Non-Cluster Setup

The following images shows a sample of direct connect mode physical connectivity for C-Series Rack-Mount Server with Cisco UCS Domain, Cisco UCS Manager, release 3.1 or later. This image shows the cabling configuration for Cisco UCS Manager integration with a C-Series Rack-Mount Server. The paths shown in gold carry both management traffic and data traffic.

The images given are only for example purpose. The equipment setup may vary depending on the server, FI, and FEX.

Figure 13: Direct Connect Cabling Configuration with Cisco VIC (Single Cable Configuration)

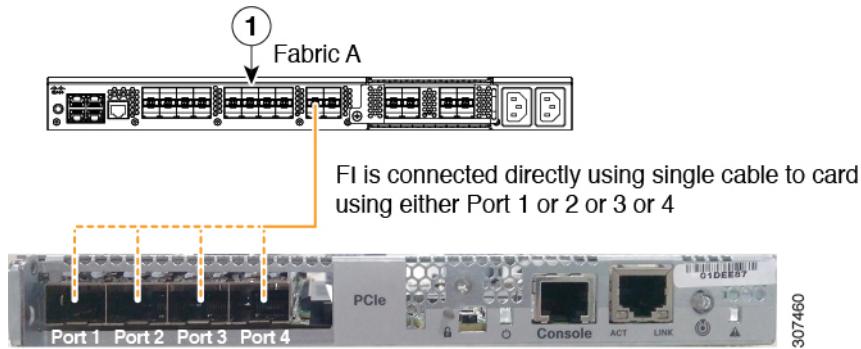
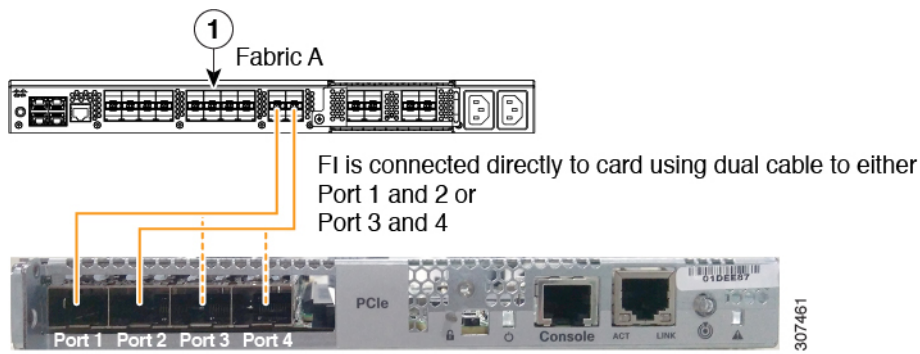

Figure 14: Direct Connect Cabling Configuration with Cisco VIC (Dual Cable Configuration)



XGb represents a Ethernet connection speed. For speed values, refer [Cisco UCS Fabric Interconnect Server Compatibility Matrix](#), on page 7. For cabling requirements, see xxx (release notes ref)

Migrating C-Series Servers from SingleConnect to Direct Connect Mode

Before performing the migration procedure, on the Cisco UCS Manager GUI, Global Policies page, make sure the **Rack Discovery Policy** and **Rack Management Connection Policies** are set to the defaults such as, **Immediate** and **Auto Acknowledge**. This ensures that, after connecting the server directly to the FI, the server is discovered immediately and Cisco UCS Manager starts managing the server without waiting for your interaction.



Caution

Migrating from SingleConnect FEX connectivity to direct connect is a disruptive process. Ensure that you do this during a scheduled outage window. You may required 15 to 20 minutes to complete this procedure.

Procedure

Step 1 Configure the server ports on the FI.

- Step 2** Disconnect the cables from the FEX and connect them to the configured server ports on Fabric Interconnect.
- Step 3** On the Cisco UCS Manager GUI, right click the server, from the pop-up menu, select **Recover Server** or **Server Maintenance**.
- Step 4** Click **Re-acknowledge** and select **OK**.
This will cause server reboot.

After the server reboots, you can resume normal operations.

Migrating C-Series Servers from Dual-wire Management to Direct Connect Mode

Before performing the migration procedure, on the Cisco UCS Manager GUI, Global Policies page, make sure the **Rack Discovery Policy** and **Rack Management Connection Policies** are set to the defaults such as, **Immediate** and **Auto Acknowledge**. This will make sure after connecting the server directly to the FI, the server is discovered immediately and Cisco UCS Manager starts managing the server without waiting for your interaction.



Caution

- Migrating from Dual-wire FEX connectivity to direct connect is a disruptive process. Make sure you do this during a scheduled outage window. You might need 15 to 20 minutes to complete this procedure.
- You must decommission the server before performing the migration.

To enable direct connect mode to a server connected in dual-wire management mode, you will need to change the adapter. Changing the adapter may impact the PCIe numbering on a bare metal Windows system. If you had Adapters listed in the OS, after you change them they will be Adapter 3 and 4. If you are using static addressing, you will need to remove the previous adapters from the server. For more information, see <http://support.microsoft.com/kb/269155>

Procedure

- Step 1** Configure the server ports on the FI.
- Step 2** Decommission the server.
- Step 3** If you are not using Cisco UCS VIC 1225, Cisco UCS VIC 1227, Cisco UCS VIC 1385, or Cisco UCS VIC 1455, change the Cisco UCS VIC physically in the server:
- a) Unplug power cable, management LOMs and SFP twinax connections from the back of the server.
 - b) Slide the server out of the rack and remove the top cover.
 - c) Remove the PCIe riser card from the slot and remove the existing Adapter and then install Cisco UCS VIC 1225.
 - d) Reinstall the PCIe riser card into the slot, place the top cover back on the server and push the server back into the rack.
 - e) (Optional) If you would no longer require the FEX to connect any server in dual wire mode, unplug the FEX from Cisco UCS Manager, and power and remove the FEX from the rack server.

Step 4 Connect the SFP twinax cables from the Cisco VIC port to the FI ports.

Step 5 Reconnect the power cable to the server.
CIMC has standby, so you need not power the server.

What to do next

Recommission the server from Cisco UCS Manager GUI. After the recommission is complete, the server is ready for operation and you can apply service profiles to the server.

Managing the Rack-Mount Server in Cisco UCS Manager after Integration

You can manage and monitor all rack-mount servers that have been integrated with a Cisco UCS domain through Cisco UCS Manager. After the integration, you can perform all rack-mount server management tasks only through the service profiles from Cisco UCS Manager GUI or Cisco UCS Manager CLI. The C-Series Rack-Mount Server Cisco IMC is not accessible when you start managing the server with Cisco UCS Manager.

Cisco UCS Manager provides information, errors, and faults for each rack-mount server that was discovered.

For more information on managing C-Series Rack-Mount Servers from Cisco UCS Manager, see the chapter on Managing Rack-Mount Servers in your release specific [Cisco UCS Manager Configuration Guide](#).

Reverting a Server From Cisco UCS Domain Mode to Standalone Mode

When you manage a Cisco UCS C-Series server with Cisco UCS Manager software, a UCS Manager service profile is associated with the server. If you want to revert a C-Series server to standalone mode (so that it can be managed by Cisco IMC software), you must do the following actions in UCS Manager:

Procedure

- Step 1** Disassociate the UCS Manager service profile from the server.
- Step 2** Remove the connections from the adapter.
- Step 3** Manually power on the server.
- Step 4** Connect the front panel KVM connection.
- Step 5** Press **F8** during the boot up.
- Step 6** Reset Cisco IMC to factory defaults or stand-alone mode.

Caution If you do not disassociate the service profile from the server, MAC and WWN numbers assigned by Cisco UCS Manager might be kept by the server. This can cause numbering duplication and conflicts with other servers that are managed by Cisco UCS Manager. Also, if you revert a server to standalone mode without disassociating the service profile, any LSI RAID controller may not show as a bootable device in the standalone server, preventing local booting.

Special Considerations for Integrated Servers

When you connect the C-Series servers in Cisco UCS system, make sure to review the following information:

- [Single Link Port Channel between VIC 1455, VIC 1457, or VIC 1467 Adapters and Cisco UCS 6300 Fabric Interconnects, on page 67](#)

Single Link Port Channel between VIC 1455, VIC 1457, or VIC 1467 Adapters and Cisco UCS 6300 Fabric Interconnects

Cisco UCS Manager Release 4.0(1a) and later support only single link port channel between VIC 1455, 1457, or 1467 adapters on direct-connect rack-servers to Cisco UCS 6300 Series Fabric Interconnects.

Do not add a second port channel link between VIC 1455, 1457, or 1467 adapters and Cisco UCS 6300 Series Fabric Interconnects.



CHAPTER 4

Configuring Dual-Wire Management

This chapter includes the following sections:

- [Dual-Wire Management, on page 69](#)
- [Requirements or Dual_Wire Integration with Cisco UCS Manager, on page 69](#)
- [Connecting the C-Series Server with Cisco UCS Domain in Cluster Setup, on page 72](#)
- [Connecting the C-Series Server with Cisco UCS Domain in Non-Cluster Setup, on page 74](#)
- [Managing the Rack-Mount Server in Cisco UCS Manager after Integration, on page 75](#)
- [Reverting a Server From Cisco UCS Domain Mode to Standalone Mode, on page 75](#)
- [Special Considerations for Integrated Servers, on page 76](#)

Dual-Wire Management

Cisco UCS Manager supports the existing rack server integration and management option through Shared LOM, using two separate cables for data traffic and management traffic. The prerequisites for integration with Cisco UCS Manager are built into the C-Series servers. Make sure you have correct server firmware for integration with Cisco UCS Manager. If not, upgrade your server firmware before integrating the server with Cisco UCS Manager. See [Cisco UCS Host Upgrade Utility, User Guide](#).

Requirements or Dual_Wire Integration with Cisco UCS Manager

Requirements for Cluster Setup

You must have the following items to create a dual-wire integration for C-Series Rack-Mount Server with Cisco UCS Manager in cluster setup:

- A Cisco UCS system that is running Cisco UCS Manager.
- Any of the C-Series Rack-Mount Servers and corresponding Cisco IMC and UCS Manager release versions listed in [#unique_59 unique_59_Connect_42_d23e63](#).
- Two Cisco UCS VIC cards and two Cisco UCS FIs. See [Cisco UCS Fabric Interconnect Server Compatibility Matrix, on page 7](#) for adapter and FI compatibility with your server. To enable SingleConnect for the Cisco UCS Manager integration, you must have a Cisco VIC installed in the

specific slot assigned for SingleConnect in the rack server. If the VIC is not in the specific slot, SingleConnect does not work.



Note Dual-Wire Management is supported only with Cisco VIC adapters and not with third-party adapters.

Minimum Required Version of Cisco IMC, BIOS and Cisco UCS Manager for Dual-Wire Integration

Table 34: Minimum Required Version of Cisco IMC, BIOS and Cisco UCS Manager

Server	Cisco IMC	Cisco IMC BIOS	Cisco UCS Manager	UCS Manager (BIOS)
Cisco UCS C225 M8 Server	4.3(5.240021)	435a00904241155.gbin	4.3(5a)	C225M8.4.3.5a.0.0904241155.gbin
Cisco UCS C245 M8 Server	4.3(4.241014)	C245M8.4.3.4a.0.0520240849	4.3(4b)	ucs-c245-m8-bios.C245M8.4.3.4a.0.0520240849.bin
Cisco UCS C240 M7 Server	4.3.1.230097	C240M7.4.3.1a.0	4.3(2b)	ucs-c240-m7-bios.C240M7.4.3.2a.0.0710230213.bin
Cisco UCS C220 M7 Server	4.3.1.230097	C220M7.4.3.1a.0	4.3(2b)	ucs-c220-m7-bios.C220M7.4.3.2a.0.0710230213.bin
Cisco UCS C220 M6 Server	4.2(1)	4.2(1)	4.2(1)	4.2(1)
Cisco UCS C240 M6 Server	4.2(1)	4.2(1)	4.2(1)	4.2(1)
Cisco UCS C220 M5 Server	3.1.1d	3.1.1i.0	3.2(1d)	3.1.1i.0
Cisco UCS C245 M6 Server	4.2(1)	4.2(1)	4.2(1)	4.2(1)
Cisco UCS C240 M5 Server	3.1.1d	3.1.1h.0	3.2(1d)	3.1.1h.0
Cisco UCS C480 M5 Server	3.1(2b)	3.1.2a.0	3.2(2b)	3.1.2a.0
Cisco UCS C480 M5 Server	3.1(2b)	3.1.2a.0	3.2(2b)	3.1.2a.0
Cisco UCS C125 M5 Server	4.0(1a)	4.0(1a)	4.0(1a)	4.0(1a)
Cisco UCS C480 M5 ML Server	4.0(2a)	4.0(2a)	4.0(2a)	4.0(2a)
Cisco UCS C240 SD M5 Server	4.1(2)	4.1(2)	4.1(2)	4.1(2)

Recommended Cisco VIC Firmware Version

Table 35: Recommended Cisco VIC Firmware Version

Server	VIC Firmware Version
Cisco UCS VIC 15238	5.3(2.32)
Cisco UCS VIC 15235	5.3(2.32)-48
Cisco UCS VIC 15425	5.3(2.32)-48
For Cisco UCS VIC 15428 MLOM	5.3(2.32)-48
Cisco UCS VIC 1495	5.3(2.32)
For Cisco UCS VIC 1467 and 1477 MLOM:	5.3(2.32)
For Cisco UCS VIC 1455 and 1457 MLOM:	5.3(2.32)
Cisco UCS VIC 1385 and 1387 MLOM	4.6(2.230015)

Recommended Cisco VIC Slot

Table 36: Cisco UCS VIC Slot

Server	PCIe Slot
Cisco UCS C225 M8 Server	MLOM, 2 and 5 Note If slots 2 and 5 are occupied with GPUs, then VICs can be placed in slots 1 and 4.
Cisco UCS C245 M8 Server	MLOM, 2 and 5 Note If slots 2 and 5 are occupied with GPUs, then VICs can be placed in slots 1 and 4.
Cisco UCS C220 M7 Server	MLOM, 1, 3
Cisco UCS C240 M7 Server	MLOM, 1, 2, 4, and 5 Note If slots 2 and 5 are occupied with GPUs, then VICs can be placed in slots 1 and 4.
Cisco UCS C220 M6 Server	MLOM, 1, 3
Cisco UCS C240 M6 Server	MLOM, 1, 2, 4, and 5 Note If slots 2 and 5 are occupied with GPUs, then VICs can be placed in slots 1 and 4.
Cisco UCS C245 M6 Server	MLOM, 1, 2, 4, and 5 Note If slots 2 and 5 are occupied with GPUs, then VICs can be placed in slots 1 and 4.
Cisco UCS C220 M5 Server	MLOM, 1 For Cisco UCS C220 M5 Server servers you can use either MLOM or VIC to integrate with Cisco UCS Manager in SingleConnect or direct connect mode.
Cisco UCS C240 M5 Server	MLOM, 1, 2, 4, 5 Note If slots 2 and 5 are occupied with GPUs, then VICs can be placed in slots 1 and 4. For Cisco UCS C240 M5 Server servers you can use either MLOM or VIC to integrate with Cisco UCS Manager in SingleConnect or direct connect mode. See Cisco UCS Manager Management for Mixed VIC Set-up, on page 33 for slot combination.
Cisco UCS C240 SD M5 Server	MLOM, 1, 2

Server	PCIe Slot
Cisco UCS C480 M5 Server	1, 2
Cisco UCS C125 M5 Server	2 Cisco UCS C125 M5 Servers do not support MLOM. For Cisco UCS C125 M5 Servers, you must place the VIC card in slot 2 only.
Cisco UCS C480 M5 Server	1, 2
Cisco UCS C480 M5 ML Server	11, 12

Cabling Considerations

Refer xx for the compatible cables. (release notes link)

Requirements for Non-Cluster Setup

If you are integrating the server in a non-cluster setup, along with the Cisco UCS Manager and C-series rack mount server, you need the following components :

- A Cisco UCS system that is running Cisco UCS Manager.
- Any of the C-Series Rack-Mount Servers and corresponding Cisco IMC and UCS Manager release versions listed in [Table 12: Minimum Required Version of Cisco IMC, BIOS and Cisco UCS Manager, on page 30](#).
- One Cisco UCS VIC cards and one Cisco UCS FI. See [Cisco UCS Fabric Interconnect Server Compatibility Matrix, on page 7](#) for adapter and FI compatibility with your server.
- Refer [Recommended Cisco VIC Firmware Version, on page 30](#).
- To enable Cisco UCS Manager integration, you must have a Cisco VIC installed in the specific slot assigned in the rack server. If the VIC is not in the specific slot, integration does not work. Refer [Cisco UCS VIC Slot for SingleConnect Integration, on page 31](#).
- Refer [Cabling Considerations, on page 32](#)

Connecting the C-Series Server with Cisco UCS Domain in Cluster Setup

Connecting the C-Series Server with Cisco UCS Domain in Cluster Setup

To view illustrations on the connectivity for each C-Series Rack-Mount Server, see [Physical Connectivity Illustrations for Cluster Setup, on page 73](#).



Important Make sure the server Cisco IMC is set to factory default settings to integrate with Cisco UCS Manager.

Procedure

-
- Step 1** Install the server in the rack. See the *Install and Upgrade Guide* for the server that you are using. The install guides are available at the following url: [Install and Upgrade Guides](#).
- Step 2** To connect the management traffic paths, do the following:
- Insert one GLC-T transceiver into a port of the FEX that is connected to Fabric A. You can use any port on the FEX.
 - Insert one GLC-T transceiver into a port of the FEX that is connected to Fabric B. You can use any port on the FEX.
 - Connect an RJ-45 Ethernet cable between a 1-Gb port on the rear panel of the server and the transceiver that you inserted into the FEX in Fabric A.
 - Connect an RJ-45 Ethernet cable between a 1-Gb port on the rear panel of the server and the transceiver that you inserted into the FEX in Fabric B.
- Step 3** To connect the data traffic paths, do the following:
- Connect a supported SFP cable between the adapter card in the server and a port on a FEX in Fabric A. You can use any port on the FEX.
 - Connect a supported SFP cable between the adapter card in the server and a port on a FEX in Fabric B. You can use any port on the FEX.
- Step 4** Connect the paths from the FEXes to the FIs. These paths carry both data and management traffic.
- Connect two a supported SFP cables between FEX A and two ports on FI A. You can use any ports on FI A, but the ports must be enabled for server traffic.
 - Connect two a supported SFP cables between FEX B and two ports on FI B. You can use any ports on FI B, but the ports must be enabled for server traffic.
 - On the FEX, you can use only the right block of eight ports for uplinks.
 - The maximum number of uplinks is eight. Based on the Cisco UCS Manager FI discovery policy the port cabling requirement between the FEX and FI vary.
 - Do not mix SFP types on an uplink. If you do, you will see `Discovery Failed` errors.
- Step 5** Attach a power cord to each power supply in your server, and then attach the power cord to a grounded AC power outlet.
- Step 6** Reboot the server.
-

Physical Connectivity Illustrations for Cluster Setup

The following image shows a samples of the physical connectivity for C-Series Rack-Mount Server with Cisco UCS Domain, Cisco UCS Manager.

This image shows the cabling configuration for Cisco UCS Manager integration with a C-Series Rack-Mount Server. The paths shown in blue carry management traffic. The paths shown in gold carry data traffic.

Figure 15: Cluster Setup Cabling Configuration

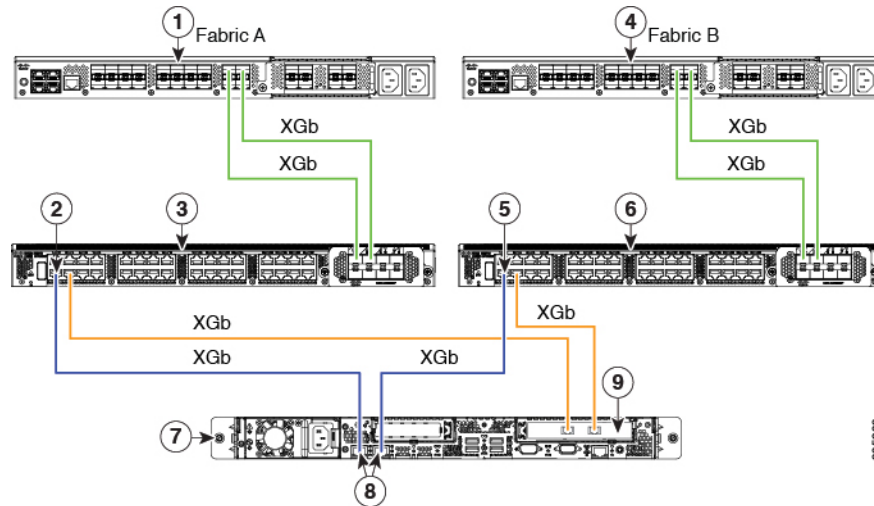

1	Cisco UCS FI (Fabric A)	6	Cisco FEX (Fabric B)
2	Cisco FEX port (Fabric A)	7	C-Series Rack-Mount Server
3	Cisco FEX (Fabric A)	8	1-Gb Ethernet LOM ports
4	Cisco UCS FI (Fabric B)	9	10-Gb Adapter card in supported PCIe or MLOM slot.
5	Cisco FEX port (Fabric B)		

Cabling Considerations

Refer xx for the compatible cables. (release notes link)

Connecting the C-Series Server with Cisco UCS Domain in Non-Cluster Setup

Connecting the C-Series Server with UCS Domain in Non-cluster Setup

To connect the C-Series server with the UCS domain, complete the same steps described in [Connecting the C-Series Server with UCS Domain in Non-cluster Setup, on page 43](#). Instead of connecting two FIs and two FEXes, you will connect only one FI and one FEX.

Figure 16: Dual-wire Non-Cluster Setup Example

The following illustration is an example of non-cluster setup in dual-wire management.

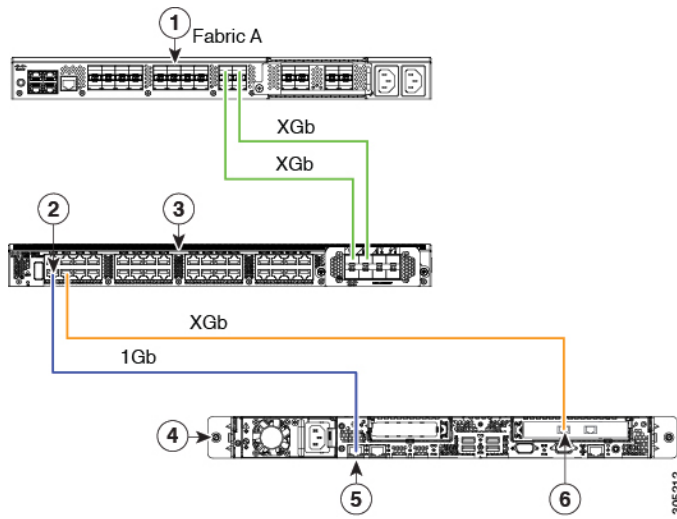

1	Cisco UCS FI (Fabric A)	4	Cisco UCS C-series server
2	Cisco FEX port (Fabric A)	5	1-Gb Ethernet LOM ports
3	FEX (Fabric A)	6	Cisco UCS VIC adapter in supported PCIe slot

Cabling Considerations

Refer xx for the compatible cables. (release notes link)

Managing the Rack-Mount Server in Cisco UCS Manager after Integration

You can manage and monitor all rack-mount servers that have been integrated with a Cisco UCS domain through Cisco UCS Manager. After the integration, you can perform all rack-mount server management tasks only through the service profiles from Cisco UCS Manager GUI or Cisco UCS Manager CLI. The C-Series Rack-Mount Server Cisco IMC is not accessible when you start managing the server with Cisco UCS Manager.

Cisco UCS Manager provides information, errors, and faults for each rack-mount server that was discovered.

For more information on managing C-Series Rack-Mount Servers from Cisco UCS Manager, see the chapter on Managing Rack-Mount Servers in your release specific [Cisco UCS Manager Configuration Guide](#).

Reverting a Server From Cisco UCS Domain Mode to Standalone Mode

When you manage a Cisco UCS C-Series server with Cisco UCS Manager software, a UCS Manager service profile is associated with the server. If you want to revert a C-Series server to standalone mode (so that it can be managed by Cisco IMC software), you must do the following actions in UCS Manager:

Procedure

-
- Step 1** Disassociate the UCS Manager service profile from the server.
 - Step 2** Remove the connections from the adapter.
 - Step 3** Manually power on the server.
 - Step 4** Connect the front panel KVM connection.
 - Step 5** Press **F8** during the boot up.
 - Step 6** Reset Cisco IMC to factory defaults or stand-alone mode.

Caution If you do not disassociate the service profile from the server, MAC and WWN numbers assigned by Cisco UCS Manager might be kept by the server. This can cause numbering duplication and conflicts with other servers that are managed by Cisco UCS Manager. Also, if you revert a server to standalone mode without disassociating the service profile, any LSI RAID controller may not show as a bootable device in the standalone server, preventing local booting.

Special Considerations for Integrated Servers

When you connect the C-Series servers in Cisco UCS system, make sure to review the following information:

- [Updating Cisco UCS VIC Firmware and uboot Image in Integrated Servers, on page 82](#)
- [Integrated Server Power States vs Service Profile Power States, on page 77](#)
- [Cautions and Limitations for Adapter Cards, on page 77](#)
- [FEX Considerations, on page 77](#)

Supported FEX-to-FI Uplink Cable SFP Types

The C-Series UCSM integration requires six 10-Gb SFP cables for the following purposes:

- Linking the data traffic paths between server and FEX - 2 cables
- Uplinks from the FEXes to the FIs - 4 cables

Each of the four uplinks from the FEXes to the FIs can use either a Cisco 10-Gb twinax cable, or one of the following SFP types:

- SFP-10GE-SR
- FET-10GE



Caution Do not mix SFP types on an uplink. If you mix SFP types on an uplink, you will get **Discovery failed** errors.

Integrated Server Power States vs Service Profile Power States

Using the power button or Cisco UCS Manager, if you set the desired power status to Down for an integrated C-Series server's associated service profile, when you try to rest the server to the desired power state, the server becomes out of sync with the actual power state. This may cause the server to shut down unexpectedly at a later time.

Use the Boot Server action in Cisco UCS Manager to safely reboot a server from a power-down state.

The following table shows how the physical server power states can differ from the Cisco UCS Manager service profile power states when the power button on the server is used.

Table 37: Difference in Server Power State and Service Profile Power State

Initial Service Profile Power State	Server Initial Power State	Action From Physical Power Button	Actual Server Power State After the Action	Power State Under UCSM Equipment Tab	Desired Power State Under Service Profile
Down	Off	Push button to turn on	On	On	Down
Up	On	Push button to turn off	Off	Off	Up

Cautions and Limitations for Adapter Cards

Make sure to consider the following when using the adapter cards in Cisco UCS C-Series server integration with Cisco UCS Manager:

- Cisco UCS Manager supports only four UCS managed adapter cards in the integrated Cisco UCS C-series servers, even if the server has more than four PCI slots. If you have more than four adapter cards in the server, after integration, the rack server discovery fails in Cisco UCS Manager.
- When you add, remove, or replace an adapter card in a UCS-managed server, you must first decommission the server in Cisco UCS Manager. After the operation, you must then recommission the server.
- If you install more than one adapter in the server each adapter in a cluster UCS Manager environment, each adapter must be connected to both path A and B. Attempting to connect both ports on an adapter to a single path results in a discovery failure due to an unsupported configuration. If you attempt to connect only one link from each adapter to the fabric, the server may reboot during a card failure to rediscover the data pathways. Neither of these scenarios are supported with connectivity options.

FEX Considerations

Re-acknowledge Attached Servers After a FEX Is Decommissioned/Recommissioned

Whenever you decommission or recommission a Cisco UCS FEX, all the servers that are connected to that FEX must be re-acknowledged in UCS Manager.



CHAPTER 5

Upgrading Earlier Release Version Servers for Cisco UCS Manager Integration

This chapter includes the following sections:

- [Required Items for Upgrade, on page 79](#)
- [Upgrading the C-Series Server Firmware, on page 80](#)
- [Updating Cisco UCS VIC Firmware and uboot Image in Integrated Servers, on page 82](#)
- [Migrating the Configuration to Release 3.1 or Higher, on page 84](#)

Required Items for Upgrade

The following are the minimum Server Cisco IMC version and Cisco UCS Manager version requirements for upgrade for C-Series server integration with Cisco UCS Manager:

Table 38: Minimum Required Version of Cisco IMC, BIOS and Cisco UCS Manager

Server	Cisco IMC	Cisco IMC BIOS	Cisco UCS Manager	UCS Manager (BIOS)
Cisco UCS C225 M8 Server	4.3(5.240021)	435a00904241155.gbin	4.3(5a)	C225M8.4.3.5a.0.0904241155.gbin
Cisco UCS C245 M8 Server	4.3(4.241014)	C245M8.4.3.4a.0.0520240849	4.3(4b)	ucs-c245-m8-bios.C245M8.4.3.4a.0.0520240849.bin
Cisco UCS C240 M7 Server	4.3.1.230097	C240M7.4.3.1a.0	4.3(2b)	ucs-c240-m7-bios.C240M7.4.3.2a.0.0710230213.bin
Cisco UCS C220 M7 Server	4.3.1.230097	C220M7.4.3.1a.0	4.3(2b)	ucs-c220-m7-bios.C220M7.4.3.2a.0.0710230213.bin
Cisco UCS C220 M6 Server	4.2(1)	4.2(1)	4.2(1)	4.2(1)
Cisco UCS C240 M6 Server	4.2(1)	4.2(1)	4.2(1)	4.2(1)
Cisco UCS C220 M5 Server	3.1.1d	3.1.1i.0	3.2(1d)	3.1.1i.0
Cisco UCS C245 M6 Server	4.2(1)	4.2(1)	4.2(1)	4.2(1)
Cisco UCS C240 M5 Server	3.1.1d	3.1.1h.0	3.2(1d)	3.1.1h.0
Cisco UCS C480 M5 Server	3.1(2b)	3.1.2a.0	3.2(2b)	3.1.2a.0
Cisco UCS C480 M5 Server	3.1(2b)	3.1.2a.0	3.2(2b)	3.1.2a.0
Cisco UCS C125 M5 Server	4.0(1a)	4.0(1a)	4.0(1a)	4.0(1a)
Cisco UCS C480 M5 ML Server	4.0(2a)	4.0(2a)	4.0(2a)	4.0(2a)
Cisco UCS C240 SD M5 Server	4.1(2)	4.1(2)	4.1(2)	4.1(2)

Upgrading the C-Series Server Firmware

If your server CIMC release version does not meet the requirement for integration with Cisco UCS Manager, make sure to upgrade the server firmware before connecting the server with Cisco UCS domain. For more information on upgrading the C-Series server firmware, see the host upgrade utility quick start guide for your release http://www.cisco.com/en/US/products/ps10493/products_user_guide_list.html

Procedure

Step 1

Download the HUU ISO file:

- a) Navigate to the following URL: <http://www.cisco.com/cisco/software/navigator.html>.
- b) In the middle column, click **Servers – Unified Computing**.
- c) In the right-hand column, click **Cisco UCS C-Series Rack-Mount Standalone Server Software**.
- d) Choose the name of your model of server in the right column.
- e) Click **Unified Computing System (UCS) Server Firmware**.
- f) Choose the release number.
- g) Click **Download Now** to download the `ucs-server_platform-huu-version_number.iso` file.
- h) Verify the information on the next page, and click **Proceed With Download**.
- i) Continue through the subsequent screens to accept the license agreement and browse to a location where you want to save the file.

Step 2

If you want to prepare the ISO for a local upgrade, complete this step; Otherwise, go to Step 3.

- a) Burn the ISO image onto a writable disk (CD).
- b) Connect a VGA monitor and USB keyboard to the Cisco C-Series server.
- c) Insert the disk into the USB DVD drive of the Cisco C-Series server.
- d) Go to Step 4.

Step 3

Prepare the ISO for a remote upgrade using the **KVM Console**.

- a) Use a browser to connect to the Cisco IMC GUI software on the server that you are upgrading.
- b) in the address field of the browser, enter the Cisco IMC IP address for that server, and then enter your username and password.
- c) Click **Launch KVM Console** on the toolbar to launch the **KVM Console**.
- d) In the **KVM Console**, click the **Virtual Media**.
- e) Click **Add Image** and click the `ucs-server-name-huu-version_number.iso` file.
- f) In the **Client View** area, in the **Mapped** column, check the check box for the ISO file that you added and then wait for mapping to complete.
- g) After the ISO file appears as a mapped remote device, go to Step 4.

Step 4

Boot the server and press **F6** when prompted to open the **Boot Menu** screen.

Step 5

In the **Boot Menu** screen, choose the prepared ISO:

- For a local upgrade, choose the physical or externally connected CD/DVD device and then press **Enter**.
- For a remote upgrade, choose **Cisco vKVM-Mapped vDVD1.22**, and press **Enter**.

The server boots from the selected device.

Step 6

After the HUU boots, Cisco End User License Agreement (EULA) appears, read the EULA and click:

- **I Agree** to agree with the license agreement and proceed with the update.
- **I Disagree** to cancel.

After you accept the EULA, when the **Cisco Host Upgrade Utility** window appears with a list of all the components that are available for update.

Step 7 If you want to update all the listed components, click **Update all**.

- Note**
- If you are updating to 2.0 (x) from versions 1.5(11) and before, or from version 1.5.3 both the active and the backup versions of Cisco IMC will be updated to 2.0(x).
 - During update the KVM connection will be lost, you have to reconnect to view the progress of the updates.

Step 8 If you want update specific components from the list, choose the components that you want to update.

Step 9 Click **Update**.

- Note**
- We recommend you update the firmware on all components using the **Update all** option, unless you want to specifically update the firmware of a component.
 - When you update the firmware of one of the following three components: BIOS, Cisco IMC, or CMC, we recommend that you also update the firmware of the other two components.
 - If you update the Cisco IMC firmware, click **Exit** and then **Ok** to activate the Cisco IMC firmware.
 - If you choose to update Cisco IMC and any other component with it and if you have not chosen BIOS, then on exit, you will be prompted to update the **Chassis Firmware**, click **Yes** in the confirmation box to update the chassis firmware.

This initiates the update and the status of the update is displayed in the **Update Status** column. You can also view a more detailed log of a series of activities and statuses that are involved while updating the firmware in the **Execution Logs** section.

Step 10 If you want to update the firmware of the hard disk of a server, click **Update HDD Firmware**. A window displays a list of hard disk drives on the server that support new firmware. Hard disk drives that do not support firmware upgrades are not listed.

Important Updating the firmware of the hard disk drive could result in data loss. Cisco recommends that you take a complete system backup prior to updating the firmware.

- To update the firmware of all the hard disks, click **Update All**.
With this option, HDDs with the latest firmware installed are not updated.
- To update a specific HDD, choose the HDD and click **Update**.

Step 11 Reboot the server.

Step 12 Reboot the server, and click **Last Update Verify** to verify if the update was successfully completed.

This action compares the previously updated firmware version for each component that was updated using the HUU with the current version of the firmware on the components and provides the status of the update.

Step 13 If you want to save the log files of the update status for later use, click **Save Logs**.

Log files that contain a detailed status of the update are saved to an external USB device that is connected to the server physically or through the KVM vMedia.

Note If an error occurs while updating the firmware, you are prompted to save the error log. Click **Save Logs** to save the log to an externally connected USB. This log can be used for identifying the cause of the error and troubleshooting.

Step 14 Click **Exit** to exit from the HUU.

Note

- If you have updated the Cisco IMC and not the BIOS, when you click **Exit**, Cisco IMC gets activated and you lose connectivity to the Cisco IMC and KVM.
- If you have selected LOM for update and you are on shared LOM mode, when you click **Exit**, you lose connectivity to the Cisco IMC and KVM.

What to do next

After upgrading the server to the compatible server release version, you must establish the physical connection for the server to make it a part of Cisco UCS domain. To connect the server to your Cisco UCS FEXes and FIs, see .

Updating Cisco UCS VIC Firmware and uboot Image in Integrated Servers

If your Cisco UCS VIC firmware and uboot version is earlier than 2.0(2g), when you integrate the server with any Cisco UCS Manager version, the UCS Manager software will return discovery and associate/disassociate failures. To avoid such failures you can do the following:

- Before you integrate the server with UCS System, upgrade your VIC firmware and uboot image to the required minimum 2.0(2g) level in standalone mode.
- If your server is already integrated, you cannot upgrade the VIC uboot image in the UCS Manager software. You have to remove the server from the integration and then use Cisco Host Upgrade Utility to upgrade the card and server firmware.

The following procedure provides the process to upgrade when your server is integrated with Cisco UCS Manager.

Procedure

- Step 1** Decommission the server from UCS Manager.
- Step 2** Disconnect the cables from the 1-Gb LOM ports on the server.
- Step 3** Connect an Ethernet line from your LAN to one of the 1-Gb LOM ports (not to the dedicated management port, which is disabled in UCSM mode).
- Step 4** Find the Host Upgrade Utility ISO file download for your server online and download it to a temporary location on your workstation:
- a) See the following URL: <http://www.cisco.com/cisco/software/navigator.html>

- b) Click **Unified Computing and Servers** in the middle column.
- c) Click **Cisco UCS C-Series Rack-Mount Standalone Server Software** in the right-hand column.
- d) Click your model of server in the right-hand column.
- e) Click **Unified Computing System (UCS) Server Firmware**.
- f) Click the release number that you are downloading.
- g) Click **Download Now** to download the ISO file.
- h) Verify the information on the next page, then click **Proceed With Download**.
- i) Continue through the subsequent screens to accept the license agreement and then browse to a location where you will save the ISO file.

Step 5

Prepare the ISO. For local upgrade, on a local media and for remote upgrade, as a virtual device:

Option	Description
Local upgrade	<p>Perform the steps before going to Step 3:</p> <ol style="list-style-type: none"> a. Burn the ISO image onto a writable DVD. b. Connect a VGA monitor and USB keyboard to the Cisco C-Series server. c. Insert the DVD into the DVD drive of the Cisco C-Series server or an external DVD drive.
Remote upgrade	<p>Perform the steps before going to Step 3:</p> <ol style="list-style-type: none"> a. Use a browser to connect to the CIMC Manager software on the server that you are upgrading. b. Enter the CIMC IP address for that server in the address field of the browser, then enter your user name and password. c. Launch a KVM Console window (click the KVM keyboard icon). d. When the Virtual KVM Console window launches, select Tools > Launch Virtual Media. e. In the Virtual Media Session window, click Add Image and navigate to the utility ISO file and select it. Navigate to the location where you downloaded the ISO. The ISO image is displayed in the Client View area. f. In the Virtual Media Session window, select the check box in the Mapped column for the ISO file that you added, and then wait for mapping to complete. Observe the progress in the Details area. <p>Now the ISO image is mapped to the remote device.</p>

Step 6

Boot the server and press **F6** when prompted to open the Boot Menu screen.

Step 7

On the Boot Menu screen, select the device where you prepared the ISO in Step 2:

- If you are upgrading locally, select the physical CD/DVD device and then press **Enter** (for example, SATA5:TSSCorp CDDVDW TS-L633C).
- If you are upgrading remotely, select **Cisco Virtual CD/DVD** and then press **Enter**.

The server is rebooted from the device you choose.

Step 8

A screen appears with the server BIOS and CIMC firmware versions. Answer the prompt, Have you read the Cisco EULA (end user license agreement)?

- Press **y** to accept the EULA and continue the update.
- Press **n** to read the EULA. The EULA is displayed and you are prompted to press **y** to continue the update, or **n** to cancel. If you press **n**, the server will reboot without updating.
- Press **q** to exit without updating. This selection reboots the server.

The **Host Upgrade Menu** screen displays.

- Step 9** Select the option to **Update UCS VIC**. This will update the card firmware and uboot image to the required level.
- Step 10** Select the option to **Update CIMC Firmware**. This will update the CIMC firmware.
- Step 11** Verify the firmware levels on the next screen.
- Step 12** Select the option to **Reboot the machine**.
- Step 13** When you see the F8 prompt during rebooting, press F8 to open the CIMC Configuration Utility.
- Step 14** In the CIMC Configuration Utility, select the option **CIMC Factory Default**, then press **F10** to save your changes.
- Step 15** Return the cables from the FEXes to the 1-Gb LOM ports on the server.
- Step 16** Recommission the server in UCS Manager.

Migrating the Configuration to Release 3.1 or Higher

When a Cisco UCS C-Series server is integrated with Cisco UCS Manager, discovered and associated with a service profile, you can migrate the configuration to a later version of Cisco UCS Manager.



Note

- This migration process causes server downtime.
- This procedure describes the scenario where management path from the server connects to the FEX and the data path connects directly to the FI.

Procedure

- Step 1** Shut down the server OS.
- Step 2** In Cisco UCS Manager, decommission all C-series servers from the Cisco UCS domain.
- Step 3** **Unconfigure** all FI server ports that are connected to the 2248 FEX.
Issue an NX-OS **show fex** command to verify that the FEX is unconfigured. Wait until the command return does not list the FEX.
- Step 4** Disconnect the cable that connects the FEX and the FI.
- Step 5** In Cisco UCS Manager CLI, issue a **remove fex *fex_ID*** command to remove the FEX from the database.
- Step 6** In Cisco UCS Manager GUI, **Unconfigure** all FI server ports that are connected to the server's adapter card.
- Step 7** Disconnect the cable that connects the FI and the server's adapter card.
- Step 8** Disconnect the cable that connects the FEX and the server's LOM connector.

- Step 9** Upgrade your Cisco UCS Manager software to 3.1 or higher and the FI firmware to the corresponding level.
- Step 10** Repeat steps 3 through 9 on the second fabric interconnect in your configuration.
- Step 11** Connect the C-Series server directly to your network and upgrade the firmware by using the standalone CIMC utility.
- Connect an Ethernet line from your LAN to one of the 1-Gb LOM ports on the server. Do not use the dedicated management port, this is disabled in the Cisco UCS Manager integrated mode.
 - Follow the instructions in [Upgrading the C-Series Server Firmware, on page 80](#), then return to the next step in this procedure.
- Step 12** Physically replace the Nexus 2248 FEX with a Nexus 2232PP FEX in your rack.
- Step 13** Connect the cables as shown in the image. See [Physical Connectivity Illustrations for Cluster Setup, on page 73](#)
- In this new configuration, the data and management paths both connect from the server to the FEX. The paths between the FEX and the FI carry both data and management traffic.
- Important** Issuing an NX-OS **show fex** command to verify the FEX. Wait until the command return lists the new Nexus 2232PP FEX. The FEX will automatically upgrade to the corresponding FI firmware version.
- Step 14** After both fabric interconnects are cabled, from Cisco UCS Manager, re-commission the decommissioned C-series servers.
- When the server is discovered in Cisco UCS Manager, the previously assigned service profile is automatically re-associated with the server.
-



CHAPTER 6

Troubleshooting

This chapter includes the following sections:

- [Replacing a Hardware Component on a Cisco UCS Manager Integrated C-Series Server, on page 87](#)
- [Changing Server Connectivity, on page 88](#)

Replacing a Hardware Component on a Cisco UCS Manager Integrated C-Series Server

After you replace hardware with managed firmware component on a Cisco UCS Manager integrated C-Series server, the server may fail discovery. This could be due to a corrupt firmware on the hardware or incompatibility of the hardware component's firmware. Complete the following steps to ensure server does not fail discovery due to server firmware corruption or incompatibility after hardware replacement:

Procedure

- Step 1** Right-click **Server** -> **Server Maintenance** > **Decommission Server** to decommission the server.
- Step 2** Disconnect the cables connecting the VICs to the FI (or FEX, if applicable).
- Step 3** Remove the server from Cisco UCS Manager:
- Choose **Equipment** -> **Decommissioned**.
 - Right-click on the server and click **Remove**.
- Step 4** Reboot the server and perform a **CIMC Reset to Factory Defaults**.
- Step 5** Connect a 1G cable to the MGMT port on the server and configure it for standalone access.
- Step 6** Re-image all the server firmware to match the Cisco UCS Manager firmware bundle CIMC version with the server:
- Download the Host Upgrade Utility (HUU) from Cisco's software download site for the CIMC version that corresponds to the host firmware package applied to this server in the Cisco UCS Manager.
 - Boot the server with the standalone KVM and run the HUU package.
- For information about steps to upgrade the firmware, refer to the [Host Utility Upgrade User Guide](#) that corresponds to the HUU CIMC version that was downloaded in the previous step.
- Step 7** Reboot the server and perform a **CIMC Reset to Factory Defaults**.
- Step 8** Unplug the power cables for 30 seconds.

- Step 9** Reconnect the uplink cables.
- Step 10** Connect the power cables and power on.
- Step 11** Verify if the server displays on the Cisco UCS Manager, this may take a few minutes.
- Step 12** After the server appears, re-acknowledge the server, if the rack server discovery policy is set to user acknowledge.
-

Changing Server Connectivity

Cisco UCS Manager maintains a mapping of which ports integrated rack servers are connected on.

When moving an integrated rack server or cabling of a chassis to a different Fabric Interconnect (FI) ports, the following procedure must be followed.

Procedure

- Step 1** Decommission the rack server that needs to be moved (or S3260 chassis, if applicable).
- In the **Navigation** pane, click **Equipment**.
 - Expand **Equipment** > **Rack Mounts** > **Servers**.
 - Choose the server that you want to decommission.
 - In the **Work** pane, click the **General** tab.
 - In the **Actions** area, click **Server Maintenance**.
 - In the **Maintenance** dialog box, do the following:
 - Click **Decommission**.
 - Click **OK**.

The server is removed from the Cisco UCS configuration.

- Step 2** Disconnect the cables connecting the VICs to the FIs (or FEX, if applicable).
- Step 3** Connect the cables to the new ports on the FIs (or FEX, if applicable).
- Step 4** Recommission the server (or S3260 chassis, if applicable).
- In the **Navigation** pane, click **Equipment**.
 - In the **Work** pane, click the **Decommissioned** tab.
 - On the row for each rack-mount server that you want to recommission, check the check box in the Recommission column.
 - Click **Save Changes**.
- Step 5** Verify if the server displays on the Cisco UCS Manager, this may take a few minutes.
- Step 6** Monitor the progress of the server recommission and discovery on the FSM tab for the server.
-