

# Cisco UCS Integrated Infrastructure for SAP HANA

Design and Deployment of Cisco UCS M5 Servers and MapR Converged Data Platform with SUSE Linux Enterprise Server

**Last Updated:** April 4, 2018



About the Cisco Validated Design Program

The Cisco Validated Design (CVD) program consists of systems and solutions designed, tested, and documented to facilitate faster, more reliable, and more predictable customer deployments. For more information, visit:

<http://www.cisco.com/go/designzone>.

ALL DESIGNS, SPECIFICATIONS, STATEMENTS, INFORMATION, AND RECOMMENDATIONS (COLLECTIVELY, "DESIGNS") IN THIS MANUAL ARE PRESENTED "AS IS," WITH ALL FAULTS. CISCO AND ITS SUPPLIERS DISCLAIM ALL WARRANTIES, INCLUDING, WITHOUT LIMITATION, THE WARRANTY OF MERCHANTABILITY, FITNESS FOR A PARTICULAR PURPOSE AND NONINFRINGEMENT OR ARISING FROM A COURSE OF DEALING, USAGE, OR TRADE PRACTICE. IN NO EVENT SHALL CISCO OR ITS SUPPLIERS BE LIABLE FOR ANY INDIRECT, SPECIAL, CONSEQUENTIAL, OR INCIDENTAL DAMAGES, INCLUDING, WITHOUT LIMITATION, LOST PROFITS OR LOSS OR DAMAGE TO DATA ARISING OUT OF THE USE OR INABILITY TO USE THE DESIGNS, EVEN IF CISCO OR ITS SUPPLIERS HAVE BEEN ADVISED OF THE POSSIBILITY OF SUCH DAMAGES.

THE DESIGNS ARE SUBJECT TO CHANGE WITHOUT NOTICE. USERS ARE SOLELY RESPONSIBLE FOR THEIR APPLICATION OF THE DESIGNS. THE DESIGNS DO NOT CONSTITUTE THE TECHNICAL OR OTHER PROFESSIONAL ADVICE OF CISCO, ITS SUPPLIERS OR PARTNERS. USERS SHOULD CONSULT THEIR OWN TECHNICAL ADVISORS BEFORE IMPLEMENTING THE DESIGNS. RESULTS MAY VARY DEPENDING ON FACTORS NOT TESTED BY CISCO.

CCDE, CCENT, Cisco Eos, Cisco Lumin, Cisco Nexus, Cisco StadiumVision, Cisco TelePresence, Cisco WebEx, the Cisco logo, DCE, and Welcome to the Human Network are trademarks; Changing the Way We Work, Live, Play, and Learn and Cisco Store are service marks; and Access Registrar, Aironet, AsyncOS, Bringing the Meeting To You, Catalyst, CCDA, CCDP, CCIE, CCIP, CCNA, CCNP, CCSP, CCVP, Cisco, the Cisco Certified Internetwork Expert logo, Cisco IOS, Cisco Press, Cisco Systems, Cisco Systems Capital, the Cisco Systems logo, Cisco Unified Computing System (Cisco UCS), Cisco UCS B-Series Blade Servers, Cisco UCS C-Series Rack Servers, Cisco UCS S-Series Storage Servers, Cisco UCS Manager, Cisco UCS Management Software, Cisco Unified Fabric, Cisco Application Centric Infrastructure, Cisco Nexus 9000 Series, Cisco Nexus 7000 Series, Cisco Prime Data Center Network Manager, Cisco NX-OS Software, Cisco MDS Series, Cisco Unity, Collaboration Without Limitation, EtherFast, EtherSwitch, Event Center, Fast Step, Follow Me Browsing, FormShare, GigaDrive, HomeLink, Internet Quotient, IOS, iPhone, iQuick Study, LightStream, Linksys, MediaTone, MeetingPlace, MeetingPlace Chime Sound, MGX, Networkers, Networking Academy, Network Registrar, PCNow, PIX, PowerPanels, ProConnect, ScriptShare, SenderBase, SMARTnet, Spectrum Expert, StackWise, The Fastest Way to Increase Your Internet Quotient, TransPath, WebEx, and the WebEx logo are registered trademarks of Cisco Systems, Inc. and/or its affiliates in the United States and certain other countries.

All other trademarks mentioned in this document or website are the property of their respective owners. The use of the word partner does not imply a partnership relationship between Cisco and any other company. (0809R)

© 2018 Cisco Systems, Inc. All rights reserved.

# Table of Contents

Executive Summary .....	7
Solution Overview .....	8
Introduction .....	8
Audience .....	8
Purpose of this Document .....	8
What's New? .....	8
Solution Summary .....	9
Technology Overview .....	13
Cisco Unified Computing System .....	13
Cisco UCS Manager .....	13
Cisco UCS Fabric Interconnect .....	14
Cisco UCS 6332UP Fabric Interconnect .....	14
Cisco UCS 2304XP Fabric Extender .....	14
Cisco UCS Blade Chassis .....	15
Cisco UCS B480 M5 Blade Server .....	16
Cisco UCS C480 M5 Rack Servers .....	17
Cisco UCS C240 M5 Rack Servers .....	18
Cisco I/O Adapters for Blade and Rack-Mount Servers .....	19
Cisco VIC Interface Card .....	19
Cisco VIC 1380 Virtual Interface Card .....	19
Cisco VIC 1385 Virtual Interface Card .....	20
Cisco Unified Computing System Performance Manager .....	21
Cisco UCS Differentiators .....	21
MapR Converged Data Platform .....	23
Solution Design .....	25
SAP HANA System .....	25
Hardware Requirements for the SAP HANA Database .....	25
CPU .....	25
Memory .....	25
Network .....	26
Storage .....	28
Filesystem Layout .....	29
Operating System .....	30
High Availability .....	30
Physical Topology .....	30
Considerations .....	31
Scale .....	31
Performance .....	31

Deployment Hardware and Software .....	33
Configuration Guidelines .....	33
Topology .....	34
Physical Device Cabling .....	37
Software Revisions.....	44
Network Configuration .....	46
Cisco Nexus 3500 Series Switch Network Configuration .....	46
Cisco Nexus 3524 Initial Configuration .....	46
Enable Appropriate Cisco Nexus 3524 Switch Features and Settings.....	47
Create Global Policy to Enable Jumbo Frame and Apply the Policy to System Wide.....	47
Create VLANs for SAP HANA Traffic.....	48
Configure Network Interfaces Connecting to Cisco UCS Fabric Interconnect .....	48
Cisco Nexus 9000 Series Switch Network Configuration .....	49
Cisco Nexus 9000 A Initial Configuration.....	49
Cisco Nexus 9000 B Initial Configuration.....	51
Enable Appropriate Cisco Nexus 9000 Series Switches—Features and Settings .....	52
Create VLANs for SAP HANA Traffic.....	52
Configure Virtual Port-Channel Domain.....	53
Configure Network Interfaces for the VPC Peer Links .....	54
Configure Network Interfaces with Cisco UCS Fabric Interconnect .....	55
(Optional) Configure Network Interfaces for SAP HANA Backup/Data Source/Replication .....	56
(Optional) Management Plane Access for Cisco UCS Servers.....	58
Uplink into Existing Network Infrastructure .....	58
Cisco UCS Configuration.....	59
Initial Setup of Cisco UCS 6332 Fabric Interconnect.....	59
Cisco UCS 6332 Fabric Interconnect A .....	59
Cisco UCS 6332 Fabric Interconnect B .....	59
Cisco UCS for SAP HANA .....	60
Log in to Cisco UCS Manager.....	60
Upgrade Cisco UCS Manager Software to Version 3.2(2d) .....	60
Add Block of IP Addresses for KVM Access .....	60
Synchronize Cisco UCS to NTP.....	61
Cisco UCS Blade Chassis Connection Options .....	61
Enable Server and Uplink Ports .....	62
Configure Breakout Ports.....	63
Acknowledge Cisco UCS Chassis and Rack-Mount Servers.....	64
Create Uplink Port Channels.....	64
Create New Organization.....	67
Create MAC Address Pools .....	68
Create UUID Suffix Pool .....	69



Power Policy .....	70
Power Control Policy.....	70
Create Host Firmware Package .....	71
Create Local Disk Configuration Policy .....	72
Create Server BIOS Policy.....	74
Create Serial Over LAN Policy .....	77
Update Default Maintenance Policy .....	78
IPMI Access Profiles .....	79
Network Configuration .....	81
Set Jumbo Frames in Cisco UCS Fabric .....	81
Network Control Policy.....	81
Create Network Control Policy for Internal Network.....	82
LAN Configurations .....	83
Create VLANs .....	83
Create VLAN Groups .....	88
Create vNIC Template .....	93
Create a vNIC Template for Storage Network.....	96
Create a vNIC Template for AppServer Network.....	97
Create a vNIC Template for Backup Network .....	98
Create a vNIC Template for Client Network.....	98
Create a vNIC Template for DataSource Network .....	99
Create a vNIC Template for Replication Network .....	99
Create a vNIC Template for Management Network .....	100
Create a vNIC Template for IPMI Inband Access Network .....	100
Create a vNIC Template for MapR-01 Internal Network .....	101
Create a vNIC template for MapR-02 Internal Network.....	102
Create Boot Policies .....	102
Create IP Pool for Inband Management.....	103
Configure the Inband Profile .....	104
Create Service Profile Templates for SAP HANA Scale-Out Servers .....	104
Create Service Profile from the Template .....	114
Create Service Profile Templates for MapR Servers .....	116
Create Service Profiles .....	121
MapR Storage Configuration .....	123
MapR Server RAID Configuration .....	123
MapR Server Operating System Installation .....	131
Operating System Network Configuration .....	149
IP Address .....	150
DNS .....	151
SUSE Linux Enterprise Server 12 System Update and OS Customization for MapR Servers.....	152

Install Cisco eNIC Driver .....	153
Network Time .....	154
SSH Keys .....	154
MapR Installation .....	155
Virtual IP Range .....	155
Preparing Online Repository .....	155
Installing MapR Packages .....	155
Initial Configuration .....	156
Starting up MapR cluster .....	157
Add License to MapR Cluster .....	157
Create Virtual IPs .....	158
Create Volumes .....	159
HANA System Configuration .....	162
SUSE Operating System Installation .....	162
Operating System Network Configuration .....	178
DNS .....	181
Hosts file .....	181
SUSE Linux Enterprise Server for SAP Application 12 System Update and OS Customization for HANA Servers.....	183
Install Cisco eNIC Driver .....	184
Network Time .....	185
SSH Keys .....	185
Mount Options.....	185
SAP HANA Installation .....	187
Important SAP Notes.....	187
SAP HANA IMDB Related Notes .....	187
Linux Related Notes.....	187
SAP Application Related Notes.....	188
Third Party Software .....	188
SAP HANA Virtualization .....	188
High Availability (HA) Configuration for Scale-Out .....	188
High Availability Configuration .....	189
Enable the SAP HANA Storage Connector API .....	191
Test the IPMI Connectivity .....	191
SAP HANA Parameters for Scale-Out.....	191
SAP HANA Hardware Configuration Check Tool Parameter.....	192
About the Authors .....	194
Acknowledgements .....	194

## Executive Summary

---

Organizations in every industry are generating and using more data than ever before; from customer transactions and supplier delivery considerations to real-time user-consumption statistics. Without scalable infrastructure that can store, process, and analyze big data sets in real time, companies are unable to use this information to their advantage. The Cisco UCS Integrated Infrastructure for SAP HANA Scale-Out with the Cisco Unified Computing System™ (Cisco UCS) helps companies more easily harness information and make better business decisions that let them stay ahead of the competition. Our solutions help improve access to all of your data, accelerate business decision making with policy-based, simplified management; lower deployment risk; and reduce total cost of ownership (TCO). Our innovations give you the key to unlock the intelligence in your data and interpret it with a new dimension of context and insight to help you create a sustainable, competitive business advantage.

Cisco Validated Designs include systems and solutions that are designed, tested, and documented to facilitate and improve customer deployments. These designs incorporate a wide range of technologies and products into a portfolio of solutions that have been developed to address the business needs of customers. The Cisco UCS Integrated Infrastructure for SAP HANA with MapR Converged Data Platform provides an end-to-end architecture that demonstrate support for multiple SAP HANA workloads with high availability and server redundancy. The solution consists of Cisco UCS B-series B480-M5 blade servers and or Cisco UCS C-series C480-M5 rack mount servers as compute nodes for SAP HANA and Cisco UCS C-Series C240 rack mount servers as storage nodes. The next generation Cisco UCS Fabric Interconnect 6332 with 40 Gb Ethernet for Server Management and Storage Connectivity. Cisco UCS service profiles enable rapid and consistent server configuration, and automation simplifies ongoing system maintenance activities such as deploying firmware updates across the entire cluster as a single operation. Advanced monitoring capabilities raise alarms and send notifications about the health of the entire cluster so that you can proactively address concerns before they affect data analysis. The Storage Nodes are composed of Cisco UCS Servers with MapR Converged Data Platform, which is a modern NFS-mountable distributed filesystem. MapR-FS is a complete POSIX file system that handles raw disk I/O for big data workload with direct access to storage hardware which dramatically improving performance and scale to thousands of nodes, and trillions of files, with extremely high throughput. MapR-FS includes enterprise-grade features such as block-level mirroring for mission-critical disaster recovery as well as load balancing, and consistent snapshots for easy data recovery.

# Solution Overview

---

## Introduction

Cisco UCS Integrated Infrastructure provides a pre-validated, ready-to-deploy infrastructure, which reduces the time and complexity involved in configuring and validating a traditional data center deployment. Cisco UCS Platforms is flexible, reliable and cost effective to facilitate various deployment options of the applications while being easily scalable and manageable. The reference architecture detailed in this document highlights the resiliency, cost benefit, and ease of deployment of a SAP HANA solution. This document describing the infrastructure installation and configuration to run SAP HANA on a dedicated or shared infrastructure.

SAP HANA is SAP SE's implementation of in-memory database technology. The SAP HANA database takes advantage of the low cost main memory (RAM), data-processing capabilities of multicore processors, and faster data access to provide better performance for analytical and transactional applications. SAP HANA offers a multi-engine, query-processing environment that supports relational data (with both row- and column-oriented physical representations in a hybrid engine) as well as a graph and text processing for semi-structured and unstructured data management within the same system. As an appliance, SAP HANA combines software components from SAP optimized for certified hardware. However, this solution has a preconfigured hardware set-up and preinstalled software package that is dedicated for SAP HANA. In 2013, SAP introduced SAP HANA Tailored Datacenter Integration (TDI) option; TDI solution offers a more open and flexible way for integrating SAP HANA into the data center by reusing existing enterprise storage hardware, thereby reducing hardware costs. With the introduction of SAP HANA TDI for shared infrastructure, the Cisco UCS Integrated Infrastructure solution provides the advantage of having the compute, storage, and network stack integrated with the programmability of the Cisco Unified Computing System (Cisco UCS). SAP HANA TDI option enables organizations to run multiple SAP HANA production systems on a shared infrastructure. It also enables customers to run the SAP applications servers and SAP HANA database hosted on the same infrastructure.

For more information about SAP HANA, see the SAP Help Portal: <http://help.sap.com/hana/>.

## Audience

The intended audience for this document includes, but is not limited to, sales engineers, field consultants, professional services, IT managers, partner engineering, and customers deploying the Cisco Integrated Infrastructure for SAP HANA with MapR Converged Data Platform. External references are provided wherever applicable, but readers are expected to be familiar with the technology, infrastructure, and database security policies of the customer installation.

## Purpose of this Document

This document describes the steps required to deploy and configure a Cisco Datacenter Solution for SAP HANA. Cisco's validation provides further confirmation with regard to component compatibility, connectivity and correct operation of the entire integrated stack. This document showcases one of the variants of Cisco Integrated Infrastructure for SAP HANA. While readers of this document are expected to have sufficient knowledge to install and configure the products used, configuration details that are important to the deployment of this solution are provided in this CVD.

## What's New?

Cisco UCS Integrated Infrastructure for SAP HANA solution designed with next generation Fabric Interconnect which provides 40GbE ports. The solution is designed with 40GbE end-to-end network including Storage network. The persistent storage is configured on Cisco UCS C240 C-series servers with MapR Converged Data Platform. MapR-FS provides distributed, reliable, high performance, scalable, and full read/write data storage for SAP HANA.

## Solution Summary

The Cisco UCS Integrated Infrastructure for SAP HANA with MapR Converged Data Platform provides an end-to-end architecture with Cisco Hardware that demonstrate support for multiple SAP HANA workloads with high availability and server redundancy. The solution supports up to 16 x Cisco UCS B480-M5 B-series blade servers or 16 x Cisco UCS C480-M5 C-series rack mount servers for SAP HANA and up to 8 x Cisco UCS C240-M5 C-Series rack mount servers for storage. The next Gen Cisco UCS Fabric Interconnect 6332 with 40 GbE network bandwidth for Server Management and Network connectivity. The Cisco UCS C240-M5 servers provides persistent storage with MapR Converged Data Platform, which is a modern NFS-mountable distributed file-system. The Nexus 3000 series Ethernet switch is used for failover purpose. In case of 2304 Fabric Expander failure or link failure between Server and Fabric Interconnect, the data traffic path will use Nexus 3000 series switch for High Availability and redundancy. Figure 1 shows the Cisco UCS Integrated Infrastructure for SAP HANA block diagram with Cisco UCS C480-M5.



The reference architecture documented in the CVD consists of 8 x Cisco UCS B/C480-M5 servers for SAP HANA and 4 x Cisco UCS C240-M5 C-Series rack mount servers for storage.

---

Figure 1 Cisco UCS Integrated Infrastructure for SAP HANA with Cisco UCS C480 M5

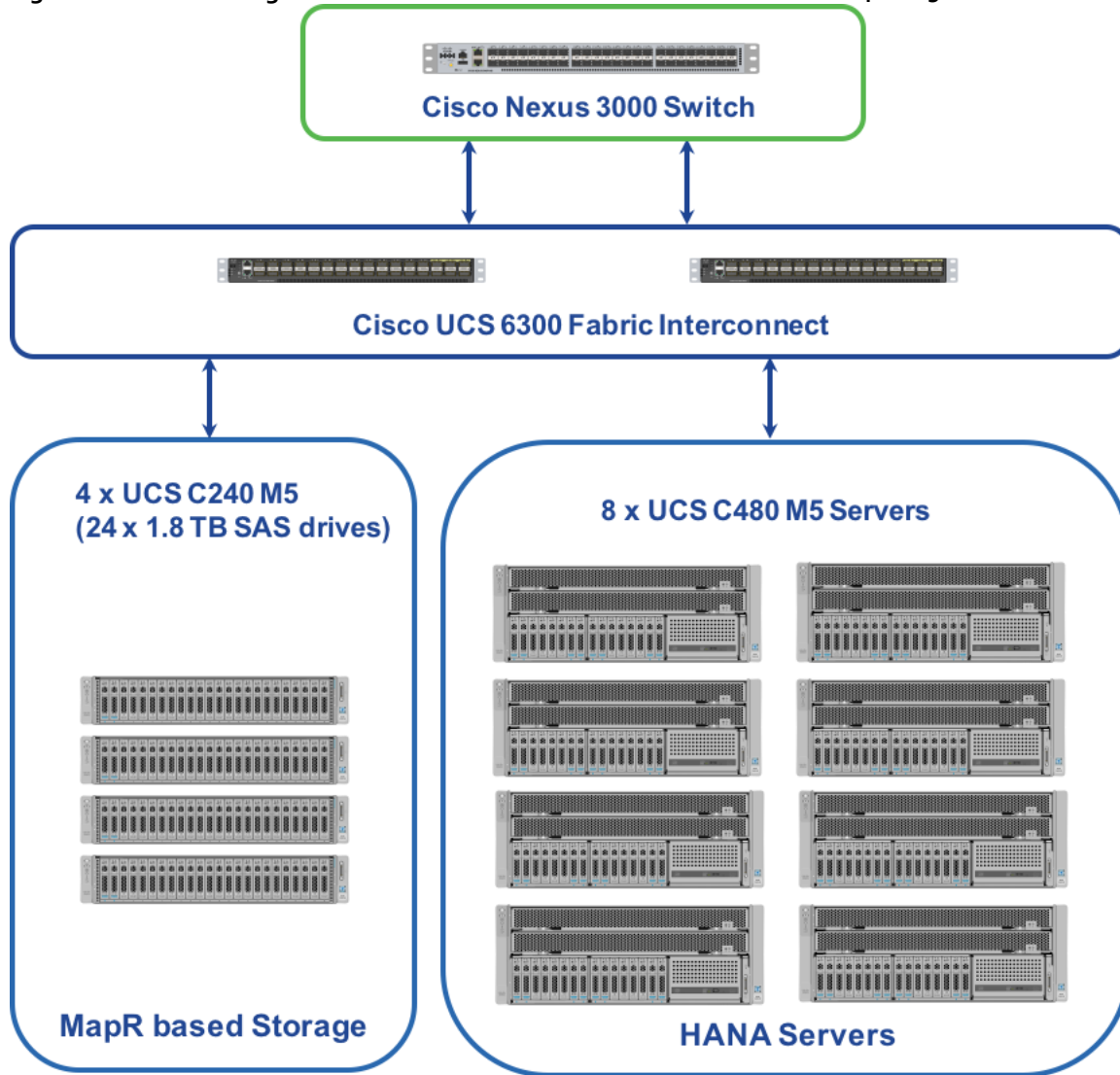
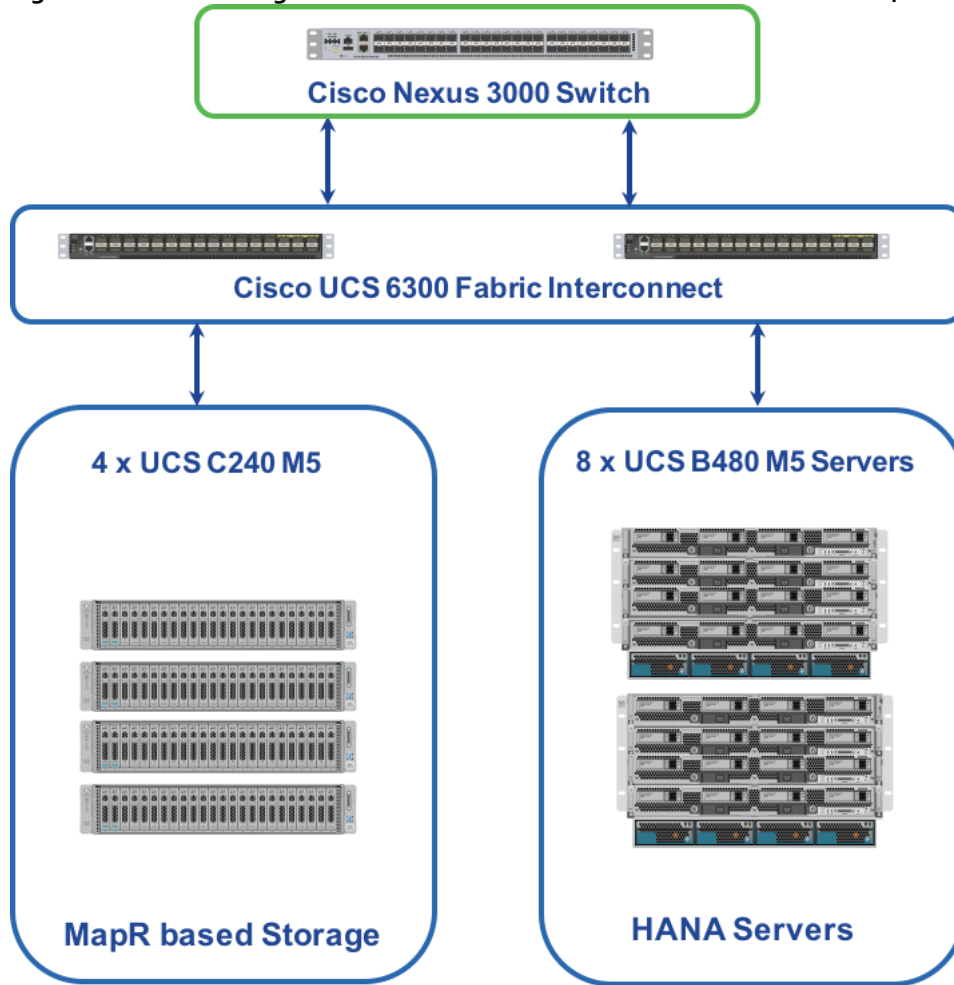

Figure 2 shows the Cisco UCS Integrated Infrastructure for SAP HANA block diagram with Cisco UCS B480 M5.

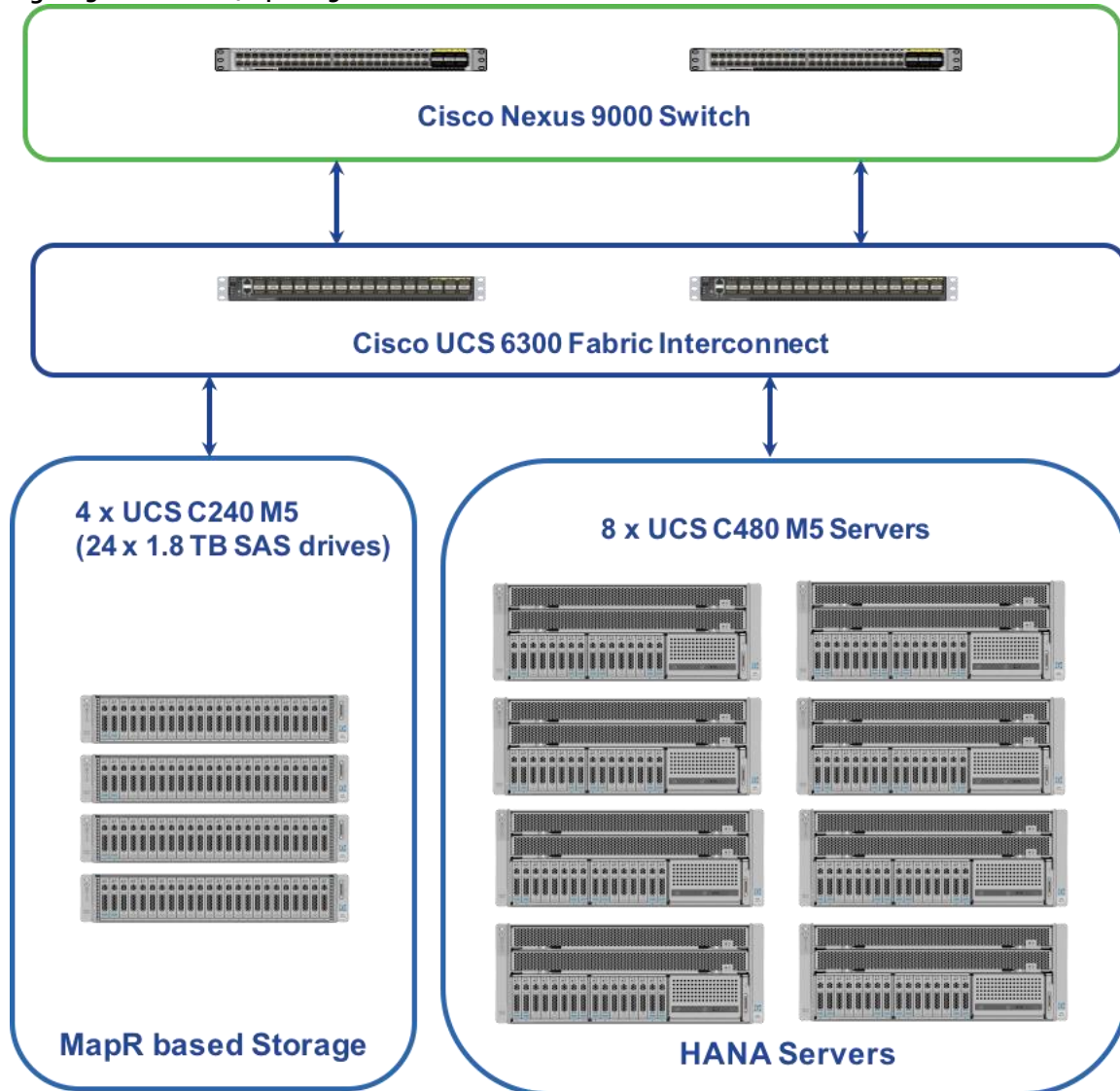

Figure 2 Cisco UCS Integrated Infrastructure for SAP HANA with Cisco UCS B480 M5



The solution can be designed with a pair for Cisco Nexus 9000 series switches, alternative to single Nexus 3000 series switch. Two Cisco Nexus 9000 series switches is configured with vPC between network switch and Cisco Fabric Interconnect as show in Figure 3.

Figure 3 Cisco UCS B/C480 M5 Scale-Out for SAP HANA Pair of Nexus Switches



## Technology Overview

---

### Cisco Unified Computing System

Cisco Unified Computing System™ (Cisco UCS®) is an integrated computing infrastructure with embedded management to automate and accelerate deployment of all your applications, including virtualization and cloud computing, scale-out and bare-metal workloads, and in-memory analytics, as well as edge computing that supports remote and branch locations and massive amounts of data from the Internet of Things (IoT). The main components of Cisco UCS: unified fabric, unified management, and unified computing resources.

The Cisco Unified Computing System is the first integrated data center platform that combines industry standard, x86-architecture servers with networking and storage access into a single unified system. The system is smart infrastructure that uses integrated, model-based management to simplify and accelerate deployment of enterprise-class applications and services running in bare-metal, virtualized, and cloud computing environments. Employing Cisco's innovative SingleConnect technology, the system's unified I/O infrastructure uses a unified fabric to support both network and storage I/O. The Cisco fabric extender architecture extends the fabric directly to servers and virtual machines for increased performance, security, and manageability. Cisco UCS helps change the way that IT organizations do business, including the following:

- Increased IT staff productivity and business agility through just-in-time provisioning and equal support for both virtualized and bare-metal environments
- Reduced TCO at the platform, site, and organization levels through infrastructure consolidation
- A unified, integrated system that is managed, serviced, and tested as a whole
- Scalability through a design for up to 160 discrete servers and thousands of virtual machines, the capability to scale I/O bandwidth to match demand, the low infrastructure cost per server, and the capability to manage up to 6000 servers with Cisco UCS Central Software
- Open industry standards supported by a partner ecosystem of industry leaders
- A system that scales to meet future data center needs for computing power, memory footprint, and I/O bandwidth; it is poised to help you move to 40 Gigabit Ethernet with the new Cisco UCS 6300 Series Fabric Interconnects

### Cisco UCS Manager

Cisco UCS Manager provides unified, embedded management of all software and hardware components of the Cisco Unified Computing System™ (Cisco UCS) and Cisco HyperFlex™ Systems across multiple chassis and rack servers and thousands of virtual machines. It supports all Cisco UCS product models, including Cisco UCS B-Series Blade Servers and C-Series Rack Servers, Cisco UCS Mini, and Cisco HyperFlex hyperconverged infrastructure, as well as the associated storage resources and networks. Cisco UCS Manager is embedded on a pair of Cisco UCS 6300 or 6200 Series Fabric Interconnects using a clustered, active-standby configuration for high availability. The manager participates in server provisioning, device discovery, inventory, configuration, diagnostics, monitoring, fault detection, auditing, and statistics collection.

An instance of Cisco UCS Manager with all Cisco UCS components managed by it forms a Cisco UCS domain, which can include up to 160 servers. In addition to provisioning Cisco UCS resources, this infrastructure management software provides a model-based foundation for simplifying the day-to-day processes of updating, monitoring, and managing computing resources, local storage, storage connections, and network connections. By enabling better automation of processes, Cisco UCS Manager allows IT organizations to achieve greater agility and scale in their infrastructure operations while reducing complexity and risk. The manager provides flexible role- and policy-based management using service profiles and templates.

Cisco UCS Manager manages Cisco UCS systems through an intuitive HTML 5 or Java user interface and a command-line interface (CLI). It can register with Cisco UCS Central Software in a multi-domain Cisco UCS environment, enabling centralized management of distributed systems scaling to thousands of servers. The manager can be integrated with Cisco UCS Director to facilitate orchestration and to provide support for converged infrastructure and Infrastructure as a Service (IaaS).

The Cisco UCS API provides comprehensive access to all Cisco UCS Manager functions. The unified API provides Cisco UCS system visibility to higher-level systems management tools from independent software vendors (ISVs) such as VMware, Microsoft, and Splunk as well as tools from BMC, CA, HP, IBM, and others. ISVs and in-house developers can use the API to enhance the value of the Cisco UCS platform according to their unique requirements. Cisco UCS PowerTool for Cisco UCS Manager and the Python Software Development Kit (SDK) help automate and manage configurations in Cisco UCS Manager.

## Cisco UCS Fabric Interconnect

The Cisco UCS 6300 Series Fabric Interconnects are a core part of Cisco UCS, providing both network connectivity and management capabilities for the system. The Cisco UCS 6300 Series offers line-rate, low-latency, lossless 10 and 40 Gigabit Ethernet, Fibre Channel over Ethernet (FCoE), and Fibre Channel functions. The Cisco UCS 6300 Series provides the management and communication backbone for the Cisco UCS B-Series Blade Servers, 5100 Series Blade Server Chassis, and C-Series Rack Servers managed by Cisco UCS. All servers attached to the fabric interconnects become part of a single, highly available management domain. In addition, by supporting unified fabric, the Cisco UCS 6300 Series provides both LAN and SAN connectivity for all servers within its domain.

From a networking perspective, the Cisco UCS 6300 Series uses a cut-through architecture, supporting deterministic, low-latency, line-rate 10 and 40 Gigabit Ethernet ports, switching capacity of 2.56 terabits per second (Tbps), and 320 Gbps of bandwidth per chassis, independent of packet size and enabled services. The product family supports Cisco® low-latency, lossless 10 and 40 Gigabit Ethernet unified network fabric capabilities, which increase the reliability, efficiency, and scalability of Ethernet networks. The fabric interconnect supports multiple traffic classes over a lossless Ethernet fabric from the server through the fabric interconnect. Significant TCO savings can be achieved with an FCoE optimized server design in which network interface cards (NICs), host bus adapters (HBAs), cables, and switches can be consolidated.

## Cisco UCS 6332UP Fabric Interconnect

The Cisco UCS 6332 Fabric Interconnect is the management and communication backbone for Cisco UCS B-Series Blade Servers, C-Series Rack Servers, and 5100 Series Blade Server Chassis. All servers attached to 6332 Fabric Interconnects become part of one highly available management domain. The Cisco UCS 6332UP 32-Port Fabric Interconnect is a 1-rack-unit 40 Gigabit Ethernet, FCoE and Fibre Channel switch offering up to 2.56 Tbps throughput and up to 32 ports. The switch has 32 fixed 40-Gbps Ethernet and FCoE ports. Cisco UCS 6332UP 32-Port Fabric Interconnect have ports that can be configured for the breakout feature that supports connectivity between 40 Gigabit Ethernet ports and 10 Gigabit Ethernet ports. This feature provides backward compatibility to existing hardware that supports 10 Gigabit Ethernet. A 40 Gigabit Ethernet port can be used as four 10 Gigabit Ethernet ports. Using a 40 Gigabit Ethernet SFP, these ports on a Cisco UCS 6300 Series Fabric Interconnect can connect to another fabric interconnect that has four 10 Gigabit Ethernet SFPs.

Figure 4 Cisco UCS 6332 UP Fabric Interconnect



## Cisco UCS 2304XP Fabric Extender

The Cisco UCS 2304 Fabric Extender has four 40 Gigabit Ethernet, FCoE-capable, Quad Small Form-Factor Pluggable (QSFP+) ports that connect the blade chassis to the fabric interconnect. Each Cisco UCS 2304 has four

40 Gigabit Ethernet ports connected through the midplane to each half-width slot in the chassis. Typically configured in pairs for redundancy, two fabric extenders provide up to 320 Gbps of I/O to the chassis.

Figure 5 Cisco UCS 2304 XP



## Cisco UCS Blade Chassis

The Cisco UCS 5100 Series Blade Server Chassis is a crucial building block of the Cisco Unified Computing System, delivering a scalable and flexible blade server.

The Cisco UCS 5108 Blade Server Chassis is six rack units (6RU) high and can mount in an industry standard 19-inch rack. A single chassis can house up to eight half-width Cisco UCS B-Series Blade Servers and can accommodate both half-width and full-width blade form factors. Four hot-swappable power supplies are accessible from the front of the chassis, and single-phase AC, -48V DC, and 200 to 380V DC power supplies and chassis are available. These power supplies are up to 94 percent efficient and meet the requirements for the 80 Plus Platinum rating. The power subsystem can be configured to support nonredundant, N+1 redundant, and grid-redundant configurations. The rear of the chassis contains eight hot-swappable fans, four power connectors (one per power supply), and two I/O bays that can support either Cisco UCS 2000 Series Fabric Extenders or the Cisco UCS 6324 Fabric Interconnect. A passive midplane provides up to 80 Gbps of I/O bandwidth per server slot and up to 160 Gbps of I/O bandwidth for two slots.

The Cisco UCS Blade Server Chassis is shown in Figure 6.

Figure 6 Cisco Blade Server Chassis (front and back view)



## Cisco UCS B480 M5 Blade Server

The enterprise-class Cisco UCS B480 M5 Blade Server delivers market-leading performance, versatility, and density without compromise for memory-intensive mission-critical enterprise applications and virtualized workloads, among others. With the Cisco UCS B480 M5, you can quickly deploy stateless physical and virtual workloads with the programmability that Cisco UCS Manager and Cisco® SingleConnect technology enable.

The Cisco UCS B480 M5 is a full-width blade server supported by the Cisco UCS 5108 Blade Server Chassis. The Cisco UCS 5108 chassis and the Cisco UCS B-Series Blade Servers provide inherent architectural advantages:

- Through Cisco UCS, gives you the architectural advantage of not having to power, cool, manage, and purchase excess switches (management, storage, and networking), Host Bus Adapters (HBAs), and Network Interface Cards (NICs) in each blade chassis
- Reduces the Total Cost of Ownership (TCO) by removing management modules from the chassis, making the chassis stateless
- Provides a single, highly available Cisco Unified Computing System™ (Cisco UCS) management domain for all system chassis and rack servers, reducing administrative tasks

The Cisco UCS B480 M5 Blade Server offers:

- Four Intel® Xeon® Scalable CPUs (up to 28 cores per socket)
- 2666-MHz DDR4 memory and 48 DIMM slots with up to 6 TB using 128-GB DIMMs
- Cisco FlexStorage® storage subsystem
- Five mezzanine adapters and support for up to four GPUs
- Cisco UCS Virtual Interface Card (VIC) 1340 modular LAN on Motherboard (mLOM) and upcoming fourth-generation VIC mLOM
- Internal Secure Digital (SD) and M.2 boot options



Figure 7 Cisco UCS B480 M5 Blade Server



## Cisco UCS C480 M5 Rack Servers

The Cisco UCS C480 M5 Rack Server is a storage and I/O optimized enterprise-class rack server that delivers industry-leading performance for in-memory databases, big data analytics, virtualization, Virtual Desktop Infrastructure (VDI), and bare-metal applications. The Cisco UCS C480 M5 delivers outstanding levels of expandability and performance for standalone or Cisco Unified Computing System™ (Cisco UCS) managed environments in a 4RU form-factor, and because of its modular design, you pay for only what you need. It offers these capabilities:

- Latest Intel® Xeon® Scalable processors with up to 28 cores per socket and support for two or four processor configurations
- 2666-MHz DDR4 memory and 48 DIMM slots for up to 6 TeraBytes (TB) of total memory
- 12 PCI Express (PCIe) 3.0 slots
  - Six x8 full-height, full length slots
  - Six x16 full-height, full length slots
- Flexible storage options with support up to 24 Small-Form-Factor (SFF) 2.5-inch, SAS, SATA, and PCIe NVMe disk drives
- Cisco® 12-Gbps SAS Modular RAID Controller in a dedicated slot
- Internal Secure Digital (SD) and M.2 boot options
- Dual embedded 10 Gigabit Ethernet LAN-On-Motherboard (LOM) ports

Cisco UCS C480 M5 servers can be deployed as standalone servers or in a Cisco UCS managed environment. When used in combination with Cisco UCS Manager, the Cisco UCS C480 M5 brings the power and automation of unified computing to enterprise applications, including Cisco® SingleConnect technology, drastically reducing switching and cabling requirements. Cisco UCS Manager uses service profiles, templates, and policy-based management to enable rapid deployment and help ensure deployment consistency. It also enables end-to-end server visibility, management, and control in both virtualized and bare-metal environments.

Figure 8 Cisco UCS C480 M5 Rack Server



## Cisco UCS C240 M5 Rack Servers

The Cisco UCS C240 M5 Rack Server is a 2-socket, 2-Rack-Unit (2RU) rack server offering industry-leading performance and expandability. It supports a wide range of storage and I/O-intensive infrastructure workloads, from big data and analytics to collaboration. Cisco UCS C-Series Rack Servers can be deployed as standalone servers or as part of a Cisco Unified Computing System™ (Cisco UCS) managed environment to take advantage of Cisco's standards-based unified computing innovations that help reduce customers' Total Cost of Ownership (TCO) and increase their business agility.

In response to ever-increasing computing and data-intensive real-time workloads, the enterprise-class Cisco UCS C240 M5 server extends the capabilities of the Cisco UCS portfolio in a 2RU form factor. It incorporates the Intel® Xeon® Scalable processors, supporting up to 20 percent more cores per socket, twice the memory capacity, and five times more. Non-Volatile Memory Express (NVMe) PCI Express (PCIe) Solid-State Disks (SSDs) compared to the previous generation of servers. These improvements deliver significant performance and efficiency gains that will improve your application performance. The Cisco UCS C240 M5 delivers outstanding levels of storage expandability with exceptional performance, along with the following:

- Latest Intel Xeon Scalable CPUs with up to 28 cores per socket
- Up to 24 DDR4 DIMMs for improved performance
- Up to 26 hot-swappable Small-Form-Factor (SFF) 2.5-inch drives, including 2 rear hot-swappable SFF drives (up to 10 support NVMe PCIe SSDs on the NVMe-optimized chassis version), or 12 Large-Form-Factor (LFF) 3.5-inch drives plus 2 rear hot-swappable SFF drives
- Support for 12-Gbps SAS modular RAID controller in a dedicated slot, leaving the remaining PCIe Generation 3.0 slots available for other expansion cards
- Modular LAN-On-Motherboard (mLOM) slot that can be used to install a Cisco UCS Virtual Interface Card (VIC) without consuming a PCIe slot, supporting dual 10- or 40-Gbps network connectivity
- Dual embedded Intel x550 10GBASE-T LAN-On-Motherboard (LOM) ports
- Modular M.2 or Secure Digital (SD) cards that can be used for boot

Cisco UCS C240 M5 servers can be deployed as standalone servers or in a Cisco UCS managed environment. When used in combination with Cisco UCS Manager, the Cisco UCS C240 M5 brings the power and automation of unified computing to enterprise applications, including Cisco® SingleConnect technology, drastically reducing switching and cabling requirements. Cisco UCS Manager uses service profiles, templates, and policy-based management to enable rapid deployment and help ensure deployment consistency. It also enables end-to-end server visibility, management, and control in both virtualized and bare-metal environments.

Figure 9 Cisco UCS C240 M5 Rack Server



## Cisco I/O Adapters for Blade and Rack-Mount Servers

This section discusses the Cisco I/O Adapters used in this solution.

### Cisco VIC Interface Card

The Cisco UCS blade server has various Converged Network Adapters (CNA) options.

The Cisco UCS Virtual Interface Card (VIC) 1340 is a 2-port 40-Gbps Ethernet or dual 4 x 10-Gbps Ethernet, Fibre Channel over Ethernet (FCoE)-capable modular LAN on motherboard (mLOM) designed exclusively for the Cisco UCS B-Series Blade Servers. When used in combination with an optional port expander, the Cisco UCS VIC 1340 capabilities is enabled for two ports of 40-Gbps Ethernet.

**Figure 10** Cisco UCS 1340 VIC Card

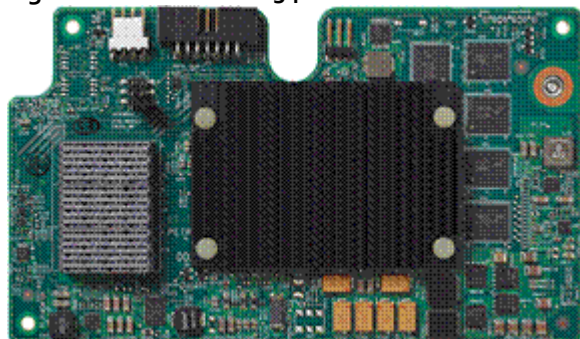

The Cisco UCS VIC 1340 enables a policy-based, stateless, agile server infrastructure that can present over 256 PCIe standards-compliant interfaces to the host that can be dynamically configured as either network interface cards (NICs) or host bus adapters (HBAs). In addition, the Cisco UCS VIC 1340 supports Cisco® Data Center Virtual Machine Fabric Extender (VM-FEX) technology, which extends the Cisco UCS fabric interconnect ports to virtual machines, simplifying server virtualization deployment and management.

### Cisco VIC 1380 Virtual Interface Card

The Cisco UCS Virtual Interface Card (VIC) 1380 is a dual-port 40-Gbps Ethernet, or dual 4 x 10 Fibre Channel over Ethernet (FCoE)-capable mezzanine card designed exclusively for the M5 generation of Cisco UCS B-Series Blade Servers. The card enables a policy-based, stateless, agile server infrastructure that can present over 256 PCIe standards-compliant interfaces to the host that can be dynamically configured as either network interface cards (NICs) or host bus adapters (HBAs). In addition, the Cisco UCS VIC 1380 supports Cisco® Data Center Virtual Machine Fabric Extender (VM-FEX) technology, which extends the Cisco UCS fabric interconnect ports to virtual machines, simplifying server virtualization deployment and management.

**Figure 11** Cisco UCS 1380 VIC Card



### Cisco VIC 1385 Virtual Interface Card

The Cisco UCS Virtual Interface Card (VIC) 1385 is a Cisco® innovation. It provides a policy-based, stateless, agile server infrastructure for your data center. This dual-port Enhanced Quad Small Form-Factor Pluggable (QSFP) half-height PCI Express (PCIe) card is designed exclusively for Cisco UCS C-Series Rack Servers. The card supports 40 Gigabit Ethernet and Fibre Channel over Ethernet (FCoE). It incorporates Cisco's next-generation converged network adapter (CNA) technology and offers a comprehensive feature set, providing investment protection for future feature software releases. The card can present more than 256 PCIe standards-compliant interfaces to the host, and these can be dynamically configured as either network interface cards (NICs) or host bus adapters (HBAs). In addition, the VIC supports Cisco Data Center Virtual Machine Fabric Extender (VM-FEX) technology. This technology extends the Cisco UCS Fabric Interconnect ports to virtual machines, simplifying server virtualization deployment.

Figure 12 Cisco UCS 1385 VIC Card

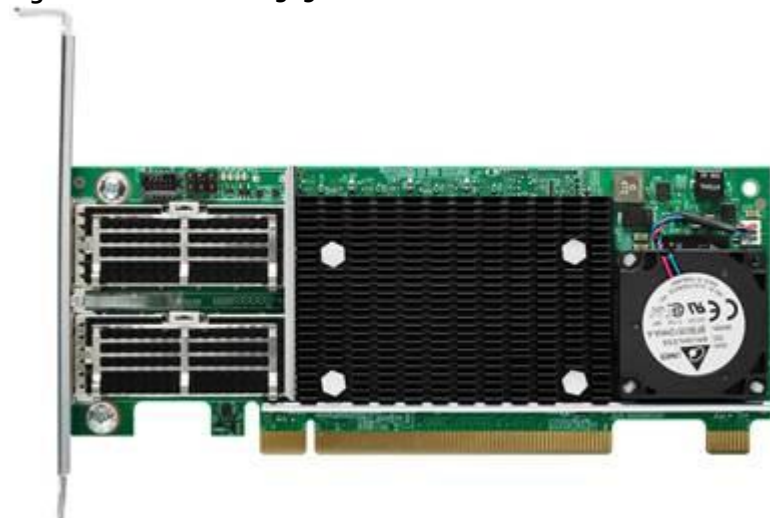

## Cisco Unified Computing System Performance Manager

Cisco UCS Performance Manager is a purpose-built data center operations management solution. It unifies the monitoring of key applications, business services, and integrated infrastructures across dynamic, heterogeneous, physical, and virtual Cisco UCS-powered data centers. Cisco UCS Performance Manager uses Cisco UCS APIs to collect data from Cisco UCS Manager to display comprehensive information about all Cisco UCS infrastructure components. With a customizable view, data center staff can see application services and view performance and component or service availability information for Cisco UCS integrated infrastructures.

Cisco UCS Performance Manager dynamically collects information about Cisco UCS servers, network, storage, and virtual machine hosts using an agentless information gathering approach. The solution provided the following:

- Unifies performance monitoring and management of Cisco UCS integrated infrastructure solutions
- Delivers real-time views of fabric and data center switch bandwidth usage and capacity thresholds
- Discovers and creates a relationship model of each system, giving staff a single, accurate view of all components
- Allows staff to navigate into individual Cisco UCS infrastructure components when troubleshooting and resolving issues

Cisco UCS Performance Manager provides deep visibility of Cisco UCS integrated infrastructure performance for service profiles, chassis, fabric extenders, adapters, virtual interface cards, ports, and uplinks for granular data center monitoring. Customers can use Cisco UCS Performance Manager to maintain service-level agreements (SLAs) by managing optimal resource allocation to prevent under-provisioning and avoid performance degradation. By defining component or application-centric views of critical resources, administrators can monitor SLA health and performance from a single console, eliminating the need for multiple tools.

For detailed information, see the [Cisco UCS Performance Manager Install Guide](#).

## Cisco UCS Differentiators

Cisco's Unified Compute System is revolutionizing the way servers are managed in data-center. The following are the unique differentiators of Cisco Unified Computing System and Cisco UCS Manager:

- **Embedded management:** In Cisco Unified Computing System, the servers are managed by the embedded firmware in the Fabric Interconnects, eliminating need for any external physical or virtual devices to manage



the servers. Also, a pair of FIs can manage up to 40 chassis, each containing 8 blade servers. This gives enormous scaling on management plane.

- **Unified fabric:** In Cisco Unified Computing System, from blade server chassis or rack server fabric extender to FI, there is a single Ethernet cable used for LAN, SAN and management traffic. This converged I/O, results in reduced cables, SFPs and adapters – reducing capital and operational expenses of overall solution.
- **Auto discovery:** By simply inserting the blade server in the chassis or connecting rack server to the fabric extender, discovery and inventory of compute resource occurs automatically without any management intervention. Combination of unified fabric and auto-discovery enables wire-once architecture of Cisco Unified Computing System, where compute capability of Cisco Unified Computing System can extend easily, while keeping the existing external connectivity to LAN, SAN and management networks.
- **Policy based resource classification:** When a compute resource is discovered by Cisco UCS Manager, it can be automatically classified to a given resource pool based on policies defined. This capability is useful in multi-tenant cloud computing. This CVD focuses on the policy-based resource classification of Cisco UCS Manager.
- **Combined Rack and Blade server management:** Cisco UCS Manager can manage Cisco UCS B-Series Blade Servers and Cisco UCS C-Series Rack Servers under the same Cisco UCS domain. This feature, along with stateless computing makes compute resources truly hardware form factor agnostic. This CVD focuses on the combination of B-Series and C-Series Servers to demonstrate stateless and form factor independent computing work load.
- **Model-based management architecture:** Cisco UCS Manager Architecture and management database is model based and data driven. Open, standard based XML API is provided to operate on the management model. This enables easy and scalable integration of Cisco UCS Manager with other management system, such as VMware vCloud director, Microsoft system center, and Citrix CloudPlatform.
- **Policies, Pools, Templates:** Management approach in Cisco UCS Manager is based on defining policies, pools and templates, instead of cluttered configuration, which enables simple, loosely coupled, data driven approach in managing compute, network and storage resources.
- **Loose referential integrity:** In Cisco UCS Manager, a service profile, port profile or policies can refer to other policies or logical resources with loose referential integrity. A referred policy cannot exist at the time of authoring the referring policy or a referred policy can be deleted even though other policies are referring to it. This provides different subject matter experts to work independently from each-other. This provides great flexibilities where different experts from different domains, such as network, storage, security, server and virtualization work together to accomplish a complex task.
- **Policy resolution:** In Cisco UCS Manager, a tree structure of organizational unit hierarchy can be created that mimics the real life tenants and/or organization relationships. Various policies, pools and templates can be defined at different levels of organization hierarchy. A policy referring to other policy by name is resolved in the org hierarchy with closest policy match. If no policy with specific name is found in the hierarchy till root org, then special policy named “default” is searched. This policy resolution practice enables automation friendly management APIs and provides great flexibilities to owners of different orgs.
- **Service profiles and stateless computing:** Service profile is a logical representation of a server, carrying its various identities and policies. This logical server can be assigned to any physical compute resource as far as it meets the resource requirements. Stateless computing enables procurement of a server within minutes, which used to take days in legacy server management systems.
- **Built-in multi-tenancy support:** Combination of policies, pools and templates, loose referential integrity, policy resolution in org hierarchy and service profile based approach to compute resources make Cisco UCS Manager inherently friendly to multi-tenant environment typically observed in private and public clouds.
- **Virtualization aware network:** VM-FEX technology makes access layer of network aware about host virtualization. This prevents domain pollution of compute and network domains with virtualization when



virtual network is managed by port-profiles defined by the network administrators' team. VM-FEX also offloads hypervisor CPU by performing switching in the hardware, thus allowing hypervisor CPU to do more virtualization related tasks. VM-FEX technology is well integrated with VMware vCenter, Linux KVM and Hyper-V SR-IOV to simplify cloud management.

- **Simplified QoS:** Even though fibre-channel and Ethernet are converged in Cisco UCS fabric, built-in support for QoS and lossless Ethernet makes it seamless. Network Quality of Service (QoS) is simplified in Cisco UCS Manager by representing all system classes in one GUI panel.

## MapR Converged Data Platform

The MapR Converged Data Platform solves the crisis of complexity that results from continually deploying workload-specific data silos. Within a single platform on a single codebase, it converges the key technologies that make up a modern data architecture, including a distributed file system, a multi-model NoSQL database, a publish/subscribe event streaming engine, ANSI SQL, and a broad set of open source data management and analytics technologies.

The MapR Converged Data Platform delivers speed, scale, and reliability, driving both operational and analytical workloads in a single platform. It is architected with many performance optimizations to get the most out of your hardware. It efficiently scales horizontally ("scale out") on commodity hardware to cost-effectively expand or contract your computing power as your load changes, even to exabyte levels. It provides mission-critical high availability (HA), disaster recovery (DR), and data recovery features to maximize uptime and reduce risk of data loss.

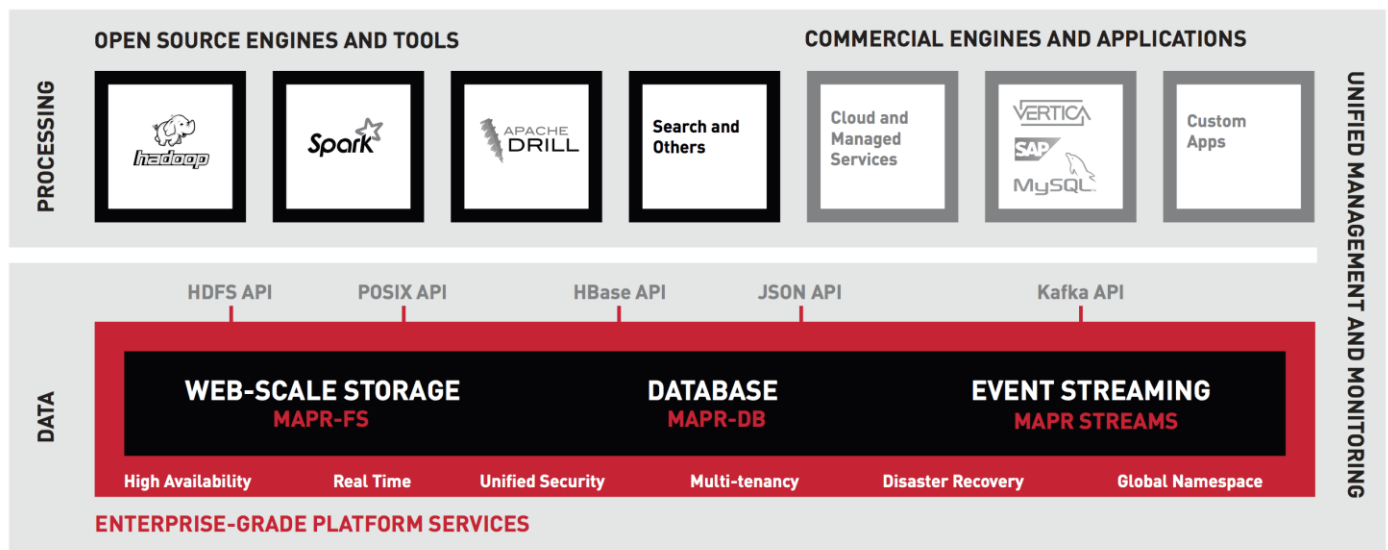

The MapR Converged Data Platform includes the following components:

- **Web-Scale Storage.** MapR-FS is a distributed POSIX file system with full read-write semantics, which can scale to exabytes of data and trillions of files in a single cluster.
- **NoSQL Database.** MapR-DB is a multi-model NoSQL database that natively supports JSON document and wide column data models with high performance, consistent low latency, strong consistency, multi-master replication, granular security, and completely automatic self-tuning.
- **Event Streaming.** MapR Streams is a publish-subscribe, event stream transport engine for reliably delivering ordered messages at high volumes and velocities.

- Apache™ Hadoop®. MapR provides open source ecosystem projects to handle a variety of big data management tasks. Projects include Apache Storm™, Apache Pig, Apache Hive™, Apache Mahout™, YARN, Apache Sqoop™, Apache Flume™, and more.
- Apache Spark™. MapR provides the full stack of the popular Spark tool set for fast, in-memory processing of big data.
- ANSI SQL. Apache Drill™ is a SQL query engine that provides low-latency results, using familiar business intelligence (BI) tools. It also queries “schemaless” data such as JSON to enable self-service data exploration and analytics.
- Third-party compute engines and custom apps. Due to interoperability features built into the system, a wide variety of third-party compute engines can run on MapR to take advantage of its speed, scale, and reliability at the data storage level.

The Cisco UCS C240 based Storage for SAP HANA takes advantage of the enterprise grade MapR-FS in MapR Platform Services. It offers the appliance a robust storage layer that is highly available, resilient and performant.

MapR converged data platform is backed by the robust MapR-FS, which can be accessed through the NFS gateway. The SAP HANA Servers mounts MapR-FS using NFS client. Data can be persisted to the storage system managed by MapR-FS. MapR-FS is distributed, has a global name space, real-time read/write access, volume based, secure and has many other benefits compared to HDFS.

For additional information, please see the [MapR File System](#).

## Solution Design

---

This section describes the SAP HANA system requirements defined by SAP and Architecture of Cisco UCS Integrated Infrastructure for SAP HANA.

### SAP HANA System

SAP HANA System on a Single Server Scale-Up, is the simplest of the installation types. It is possible to run an SAP HANA system entirely on one host and then scale the system up as needed. All data and processes are located on the same server and can be accessed locally. The network requirements for this option minimum one 1-Gb Ethernet (access) and one 10-Gb Ethernet storage networks are sufficient to run SAP HANA scale-up. SAP HANA Scale-Out option is used if the SAP HANA system does not fit into the main memory of a single server based on the rules defined by SAP. In this method, multiple independent servers are combined to form one system and the load is distributed among multiple servers. In a distributed system, each index server is usually assigned to its own host to achieve maximum performance. It is possible to assign different tables to different hosts (partitioning the database), or a single table can be split across hosts (partitioning of tables). SAP HANA Scale-Out supports failover scenarios and high availability. Individual hosts in a distributed system have different roles master, worker, slave, standby depending on the task.



Some use cases are not supported on SAP HANA Scale-Out configuration and it is recommended to check with SAP whether a use case can be deployed as a Scale-Out solution.

---

The network requirements for this option are higher than for Scale-Up systems. In addition to the client and application access and storage access network, a node-to-node network is necessary. One 10 Gigabit Ethernet (access) and one 10 Gigabit Ethernet (node-to-node) and one 10 Gigabit Ethernet storage networks are required to run SAP HANA Scale-Out system. Additional network bandwidth is required to support system replication or backup capability.

### Hardware Requirements for the SAP HANA Database

There are hardware and software requirements defined by SAP to run SAP HANA systems. This Cisco Validated Design uses guidelines provided by SAP.

For additional information, go to: <http://saphana.com>.



This document does not cover the updated information published by SAP.

---

### CPU

SAP HANA supports servers equipped with Intel(R) Xeon(R) Platinum 8176, 8176M, 8180 and 8180M CPU.

### Memory

SAP HANA Scale-Out solution is supported in the following memory configurations:

- Homogenous symmetric assembly of dual in-line memory modules (DIMMs) for example, DIMM size or speed should not be mixed
- Maximum use of all available memory channels
- Memory of 1.5 TB or 3 TB per 4 Socket Server for SAP NetWeaver Business Warehouse (BW) and DataMart

## Network

A SAP HANA data center deployment can range from a database running on a single host to a complex distributed system. Distributed systems can get complex with multiple hosts located at a primary site having one or more secondary sites; supporting a distributed multi-terabyte database with full fault and disaster recovery.

SAP HANA has different types of network communication channels to support the different SAP HANA scenarios and setups:

- Client zone: Channels used for external access to SAP HANA functions by end-user clients, administration clients, and application servers, and for data provisioning through SQL or HTTP
- Internal zone: Channels used for SAP HANA internal communication within the database or, in a distributed scenario, for communication between hosts
- Storage zone: Channels used for storage access (data persistence) and for backup and restore procedures

Table 1 lists all the networks defined by SAP or Cisco or requested by customers.

**Table 1 List of Known Networks**

Name	Use Case	Solutions	Bandwidth Requirements	Solution Design
<b>Client Zone Networks</b>				
Application Server Network	SAP Application Server to DB communication	All	1 or 10 GbE	10 or 40 GbE
Client Network	User / Client Application to DB communication	All	1 or 10 GbE	10 or 40 GbE
Data Source Network	Data import and external data integration	Optional for all SAP HANA systems	1 or 10 GbE	10 or 40 GbE
<b>Internal Zone Networks</b>				
Inter-Node Network	Node to node communication within a scale-out configuration	Scale-Out	10 GbE	40 GbE
System Replication Network	SAP HANA System Replication	For SAP HANA Disaster Tolerance	TBD with Customer	TBD with Customer
<b>Storage Zone Networks</b>				
Backup Network	Data Backup	Optional for all SAP HANA systems	10 GbE	10 or 40 GbE
Storage Network	Node to Storage communication	All	10 GbE	20 or 40 GbE
<b>Infrastructure Related Networks</b>				
Administration Network	Infrastructure and SAP HANA administration	Optional for all SAP HANA systems	1 GbE	10 or 40 GbE

Name	Use Case	Solutions	Bandwidth Requirements	Solution Design
Boot Network	Boot the Operating Systems through PXE/NFS or FCoE	Optional for all SAP HANA systems	1 GbE	N/A

For detailed information about the network requirements for SAP HANA see: [SAP HANA Network Requirements](#).

The network need to be properly segmented and must be connected to the same core/ backbone switch as shown in Figure 13 based on customer's high-availability and redundancy requirements for different SAP HANA network segments.

Figure 13 High-Level SAP HANA Network Overview

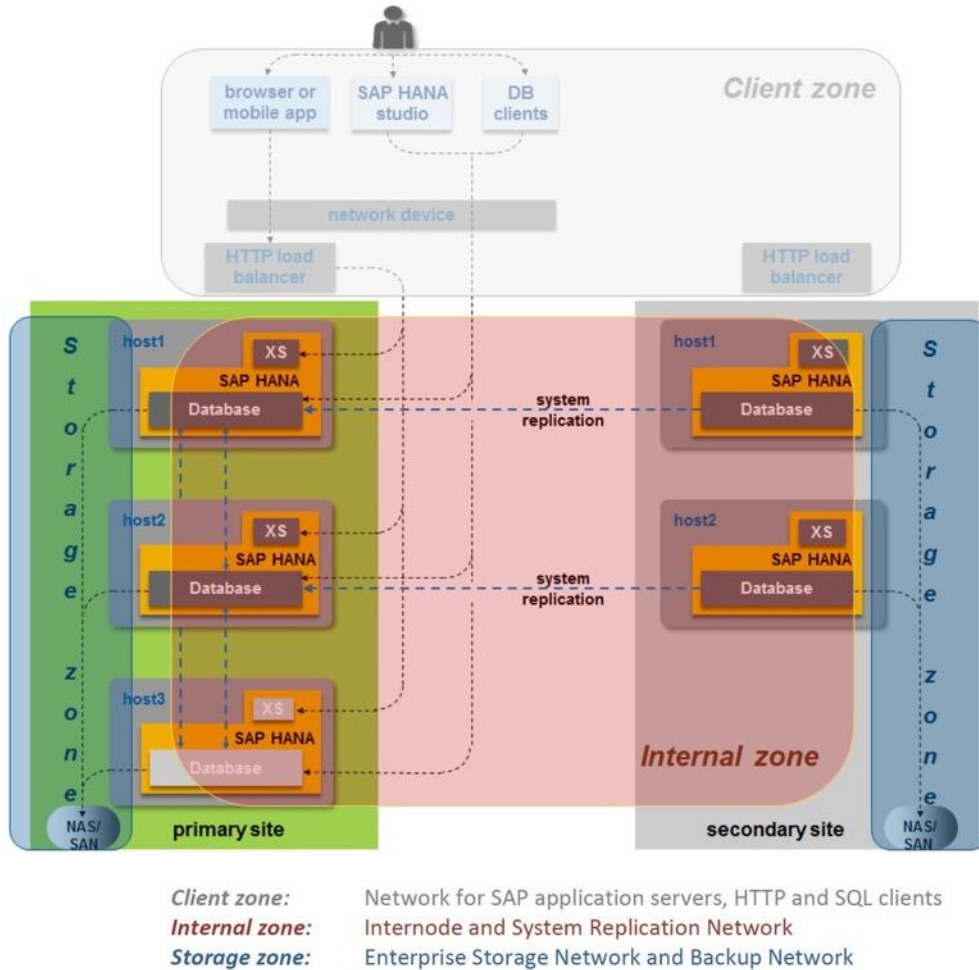

Based on the listed network requirements, every server must be equipped with 2x 10 Gigabit Ethernet for scale-up systems to establish the communication with the application or user (Client Zone) and a 10 GbE Interface for Storage access.

For scale-out solutions an additional redundant network for SAP HANA node to node communication with 10 GbE is required (Internal Zone).



For more information on SAP HANA Network security please refer to the [SAP HANA Security Guide](#).

## Storage

As an in-memory database, SAP HANA uses storage devices to save a copy of the data, for the purpose of startup and fault recovery without data loss. The choice of the specific storage technology is driven by various requirements like size, performance and high availability. To use the storage system in the Tailored Datacenter Integration option, the storage must be certified for the SAP HANA TDI option at: <http://scn.sap.com/docs/DOC-48516>.

All relevant information about storage requirements is documented in the white paper [SAP HANA Storage Requirements](#).

SAP can only support performance related SAP HANA topics if the installed solution has passed the validation test successfully.



Refer to SAP HANA Administration Guide section 2.8 Hardware Checks for Tailored Datacenter Integration for Hardware check test tool and the related documentation.

## Filesystem Layout

Figure 14 shows the file system layout and the required storage sizes to install and operate SAP HANA. For the Linux OS installation (/root) 10 GB of disk size is recommended. Additionally, 50 GB must be provided for the /usr/sap since the volume used for SAP software that supports SAP HANA.

While installing SAP HANA on a host, we specify the mount point for the installation binaries (/hana/shared/<sid>), data files (/hana/data/<sid>) and log files (/hana/log/<sid>), where sid is the instance identifier of the SAP HANA installation.

**Figure 14** File System Layout for 2 Node Scale-Out System

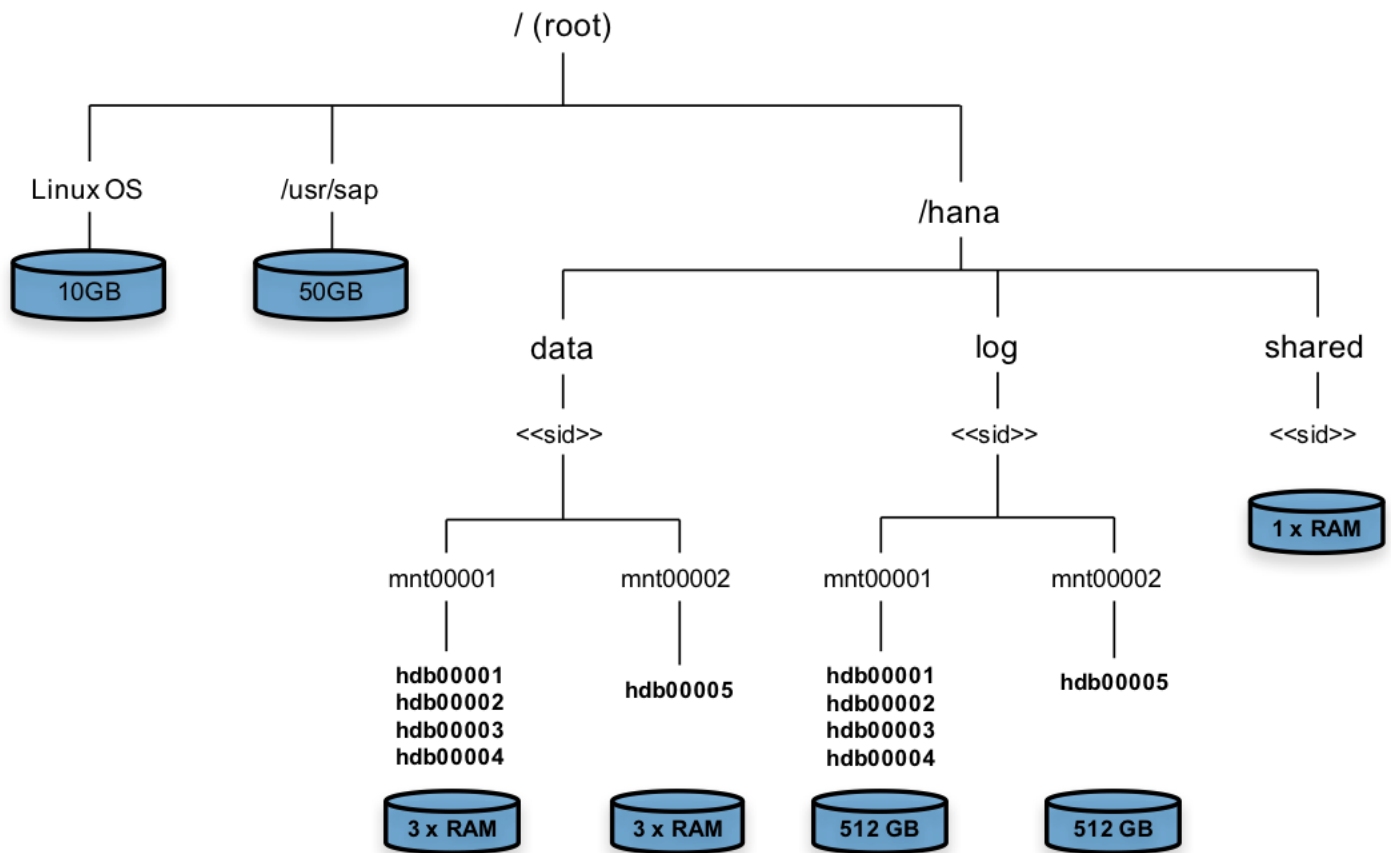

The storage sizing for filesystem is based on the amount of memory equipped on the SAP HANA host.

In case of distributed installation of SAP HANA Scale-Out, each server will have the following:

Root-FS: 10 GB

/usr/sap: 50 GB

The installation binaries, trace and configuration files are stored on a shared filesystem, which should be accessible for all hosts in the distributed installation. The size of shared filesystem should be equal to one times memory in each host for every four worker nodes. For example: In a distributed installation with eight hosts with 3 TB of memory each, shared file system should be 6 TB.

For each HANA host there should be a mount point for data and log volume.

Size of the file system for data volume for Appliance option is three times the host memory:

/hana/data/<sid>/mntXXXXX: 3 x Memory

Size of the file system for data volume with TDI option is one times the host memory:

/hana/data/<sid>/mntXXXXX: 1 x Memory

The Log volume must be as follows:

- Half of the server memory for systems  $\leq$  256 GB memory
- Min 512 GB for systems with  $\geq$  512 GB memory

## Operating System

The supported operating systems for SAP HANA are as follows:

- SUSE Linux Enterprise Server for SAP Applications
- RedHat Enterprise Linux for SAP HANA



This document provides the installation process for the SUSE Linux Enterprise Server for SAP Applications only. For RedHat Enterprise Linux option please review the Cisco Validated Design, Cisco UCS II for SAP HANA with RHEL.

---

## High Availability

The infrastructure for a SAP HANA solution must not have single point of failure. To support high-availability, the hardware and software requirements are:

- Internal storage: A RAID-based configuration is preferred
- External storage: Redundant data paths, dual controllers, and a RAID-based configuration are required
- Ethernet switches: Two or more independent switches should be used

SAP HANA Scale-Out comes with an integrated high-availability function. If a SAP HANA system is configured with a stand-by node, a failed part of SAP HANA will start on the stand-by node automatically.

For automatic host failover, storage connector API must be properly configured for the implementation and operation of the SAP HANA.

Please check the latest information from SAP at: <http://saphana.com> or <http://service.sap.com/notes>.

## Physical Topology

The Cisco UCS Integrated Infrastructure for SAP HANA with MapR Converged Data Platform provides an end-to-end architecture with Cisco Hardware that demonstrate support for multiple SAP HANA workloads with high availability and server redundancy. The architecture uses Cisco UCS Manager with combined Cisco UCS B-Series and C-Series Servers with Cisco UCS Fabric Interconnect. The uplink from Cisco UCS Fabric Interconnect is connected to Nexus 3524 switches for High Availability and Failover functionality. The Cisco UCS C-Series Rack Servers are connected directly to Cisco UCS Fabric Interconnect with single-wire management feature, the data traffic between HANA servers and Storage will be contained in the Cisco UCS Fabric Interconnect. This infrastructure is deployed to provide IP based Storage access using NFS protocols with file-level access to shared storage.

The Base Reference architecture includes:

- Cisco Unified Computing System
  - 2 x Cisco UCS 6332UP 32-Port Fabric Interconnects
  - 2 x Cisco UCS 5108 Blade Chassis with 2 x Cisco UCS 2304 Fabric Extenders with 4x 40 Gigabit Ethernet interfaces
  - 8 x Cisco UCS B480 M5 High-Performance Blade Servers with 1x Cisco UCS Virtual Interface Card (VIC) 1380 and 1x Cisco UCS Virtual Interface Card (VIC) 1340
  - Or
  - 8 x Cisco UCS C480 M5 High-Performance Rack Servers with 1x Cisco UCS Virtual Interface Card (VIC) 1385
  - 4 x Cisco UCS C240 M5 High-Performance Blade Servers with Cisco UCS Virtual Interface Card (VIC) 1385
- Cisco Network
  - For Base design:
    - 1 x Cisco Nexus 3524 Switch for 10 Gigabit Ethernet connectivity between the two Cisco UCS Fabric Interconnects for failover scenarios.

The solution can be designed for Data Center Design option using a pair for Cisco Nexus 9000 series switches. With two Cisco Nexus switches, vPC is configured between Cisco Nexus 9000 series switches and Cisco Fabric Interconnect.

- For Enterprise Data Center Design option:
  - 2 x Cisco Nexus 9372 Switch for 10 Gigabit Ethernet connectivity between the two Cisco UCS Fabric Interconnects

## Considerations

### Scale

Although this is the base design, each of the components can be scaled easily to support specific business requirements. Additional servers or even blade chassis can be deployed to increase compute capacity without additional Network components. Two Cisco UCS 6332UP, 32 port Fabric interconnect can support up to:

- 16 Cisco UCS B-Series B480 M5 Server with 8 Blade Server Chassis
- Or
- 16 Cisco UCS C-Series C480 M5 Server
- 12 Cisco UCS C240 M5 Server

A minimum of 4 x Cisco UCS C240 M5 Server is required install MapR Converged Data Platform with High Availability. 4 x Cisco UCS C240 M5 can support up to 14 Active HANA Servers. The scaling of storage to computer node is linear, for every 7 x Cisco UCS Server for Active HANA Servers, 2 x Cisco UCS C240 M5 for Storage is required to meet the SAP HANA TDI storage performance defined by SAP SE.

### Performance

The solution is designed to meet SAP HANA performance requirement defined by SAP SE. The HANA Server and Storage server are connecting to Cisco UCS Fabric Interconnect, all the data traffic between HANA node and Storage node is contained in the Cisco UCS Fabric Interconnect. Each HANA Server and Storage Server are

equipped with 2 x 40GbE capable Cisco Virtual Interface Cards, the storage network provides dedicated bandwidth between HANA servers and Storage Servers. The traffic shaping and Quality of Service (QoS) is configured and managed by Cisco UCS Fabric Interconnect. For HANA node-to-node network, 40 Gb dedicated network bandwidth is provided with non-blocking mode. The Cisco UCS Integrated Infrastructure for SAP HANA quarantines the bandwidth and latency for best performance to run SAP HANA.

## Deployment Hardware and Software

### Configuration Guidelines

This document provides details for configuring a fully redundant, highly available configuration for a Cisco UCS B/C480 M5 Scale-Out for SAP HANA.

This document is intended to enable you to fully configure the customer environment. In this process, various steps require you to insert customer-specific naming conventions, IP addresses, and VLAN schemes, as well as to record appropriate MAC addresses. Table 2 lists the configuration variables that are used throughout this document. This table can be completed based on the specific site variables and used in implementing the document configuration steps.

**Table 2 Configuration Variables**

Variable	Description	Customer Implementation Value
<<var_nexus_HA_hostname>>	Cisco Nexus 3524 HA Switch host name	
<<var_nexus_HA_mgmt0_ip>>	Out-of-band Cisco Nexus 3524 HA Switch management IP address	
<<var_nexus_HA_mgmt0_netmask>>	Out-of-band management network netmask	
<<var_nexus_HA_mgmt0_gw>>	Out-of-band management network default gateway	
<<var_global_ntp_server_ip>>	NTP server IP address	
<<var_oob_vlan_id>>	Out-of-band management network VLAN ID	
<<var_mgmt_vlan_id>>	Management network VLAN ID	
<<var_nexus_vpc_domain_mgmt_id>>	Unique Cisco Nexus switch VPC domain ID for Management Switch	
<<var_nexus_vpc_domain_id>>	Unique Cisco Nexus switch VPC domain ID	
<<var_nexus_A_hostname>>	Cisco Nexus 9000 A host name	
<<var_nexus_A_mgmt0_ip>>	Out-of-band Cisco Nexus 9000 A management IP address	
<<var_nexus_A_mgmt0_netmask>>	Out-of-band management network netmask	
<<var_nexus_A_mgmt0_gw>>	Out-of-band management network default gateway	
<<var_nexus_B_hostname>>	Cisco Nexus 9000 B host name	
<<var_nexus_B_mgmt0_ip>>	Out-of-band Cisco Nexus 9000 B management IP address	
<<var_nexus_B_mgmt0_netmask>>	Out-of-band management network netmask	
<<var_nexus_B_mgmt0_gw>>	Out-of-band management network default gateway	
<<var_mapr-01_vlan_id>>	MapR Internal network 01 VLAN ID	
<<var_mapr-02_vlan_id>>	MapR Internal network 02 VLAN ID	
<<var_storage_vlan_id>>	Storage network for HANA Data/log VLAN ID	

Variable	Description	Customer Implementation Value
<<var_internal_vlan_id>>	Node to Node Network for HANA Data/log VLAN ID	
<<var_backup_vlan_id>>	Backup Network for HANA Data/log VLAN ID	
<<var_client_vlan_id>>	Client Network for HANA Data/log VLAN ID	
<<var_appserver_vlan_id>>	Application Server Network for HANA Data/log VLAN ID	
<<var_datasource_vlan_id>>	Data source Network for HANA Data/log VLAN ID	
<<var_replication_vlan_id>>	Replication Network for HANA Data/log VLAN ID	
<<var_inband_vlan_id>>	In-band management network VLAN ID	
<<var_ucs_clustername>>	Cisco UCS Manager cluster host name	
<<var_ucsa_mgmt_ip>>	Cisco UCS fabric interconnect (FI) A out-of-band management IP address	
<<var_ucsa_mgmt_mask>>	Out-of-band management network netmask	
<<var_ucsa_mgmt_gateway>>	Out-of-band management network default gateway	
<<var_ucs_cluster_ip>>	Cisco UCS Manager cluster IP address	
<<var_ucsb_mgmt_ip>>	Cisco UCS FI B out-of-band management IP address	

## Topology

The information in this section is provided as a reference for cabling the network and compute components. For connectivity between 40GbE ports to 10GbE ports on Cisco Switches, Cisco QSFP to Four SFP+ Copper Breakout Cables are used. These breakout cables connect to a 40G QSFP port of a Cisco Fabric Interconnect on one end and to four 10G SFP+ ports of a Cisco switch on the other end

Figure 15 illustrates the cabling topology for Cisco UCS Integrated Infrastructure for SAP HANA configuration using the Cisco Nexus 3000.

Figure 15 Cabling Topology for Cisco UCS Integrated Infrastructure for SAP HANA

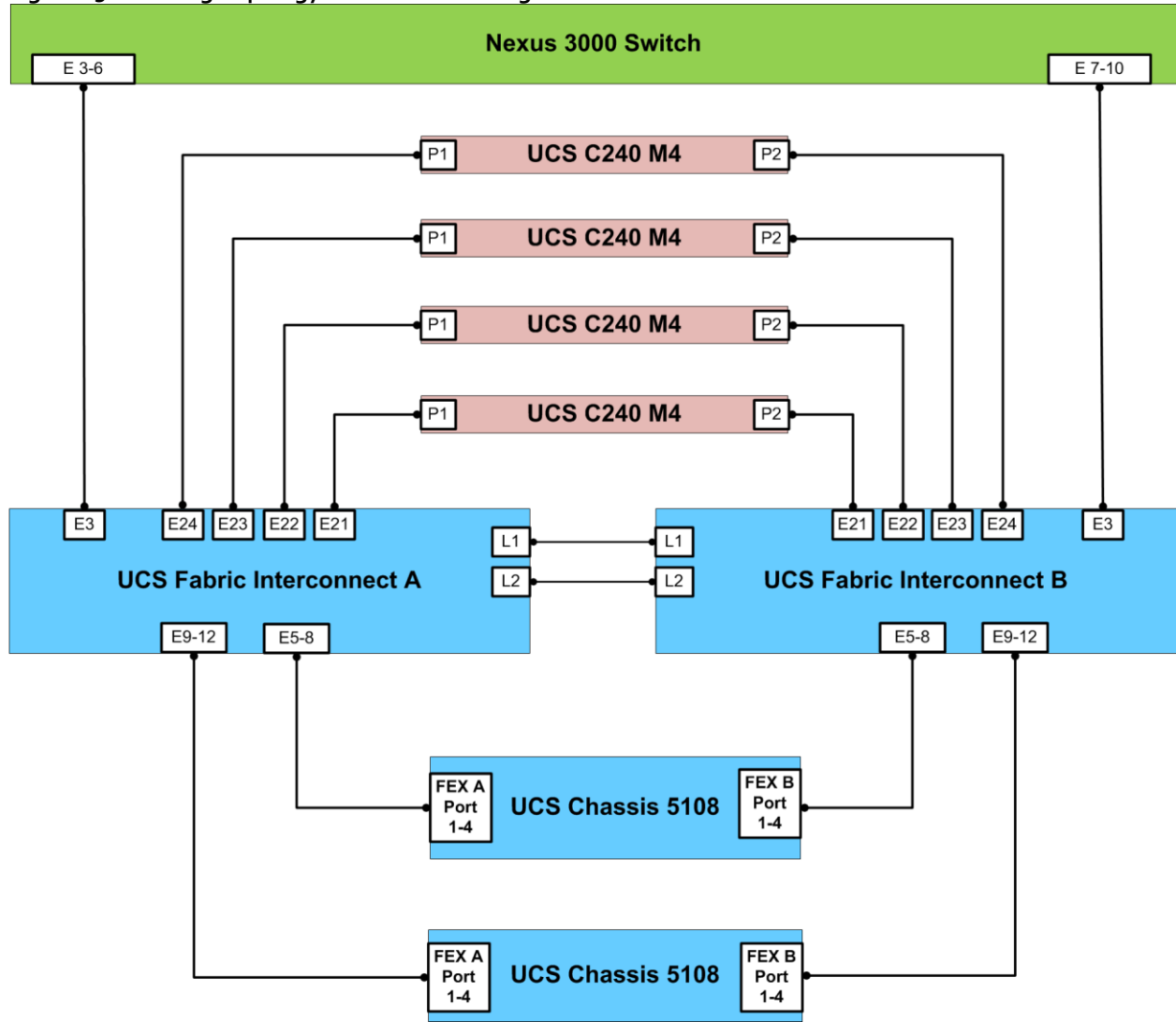



Figure 16 Cisco UCS Integrated Infrastructure for SAP HANA configuration using the Cisco Nexus 3000

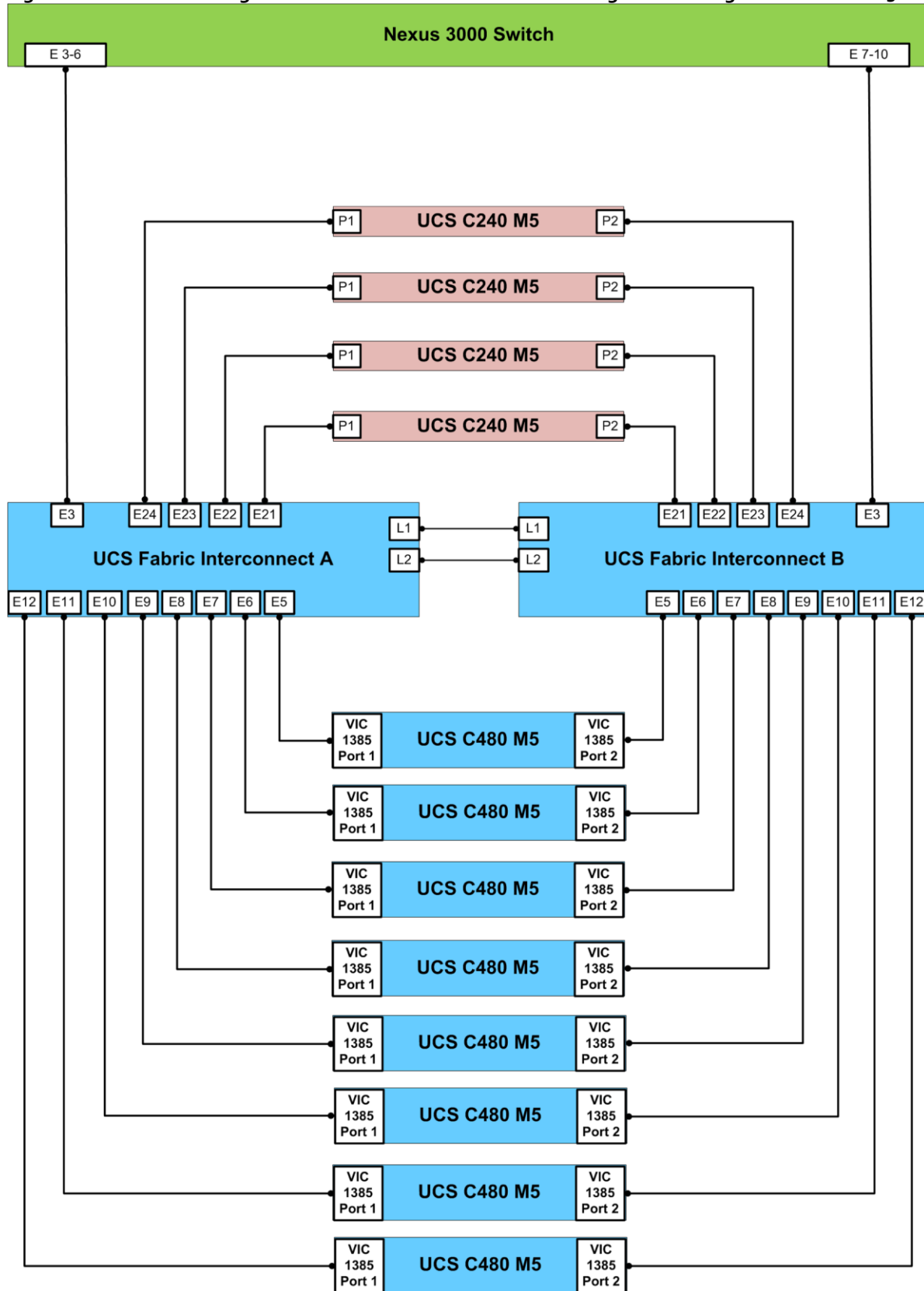
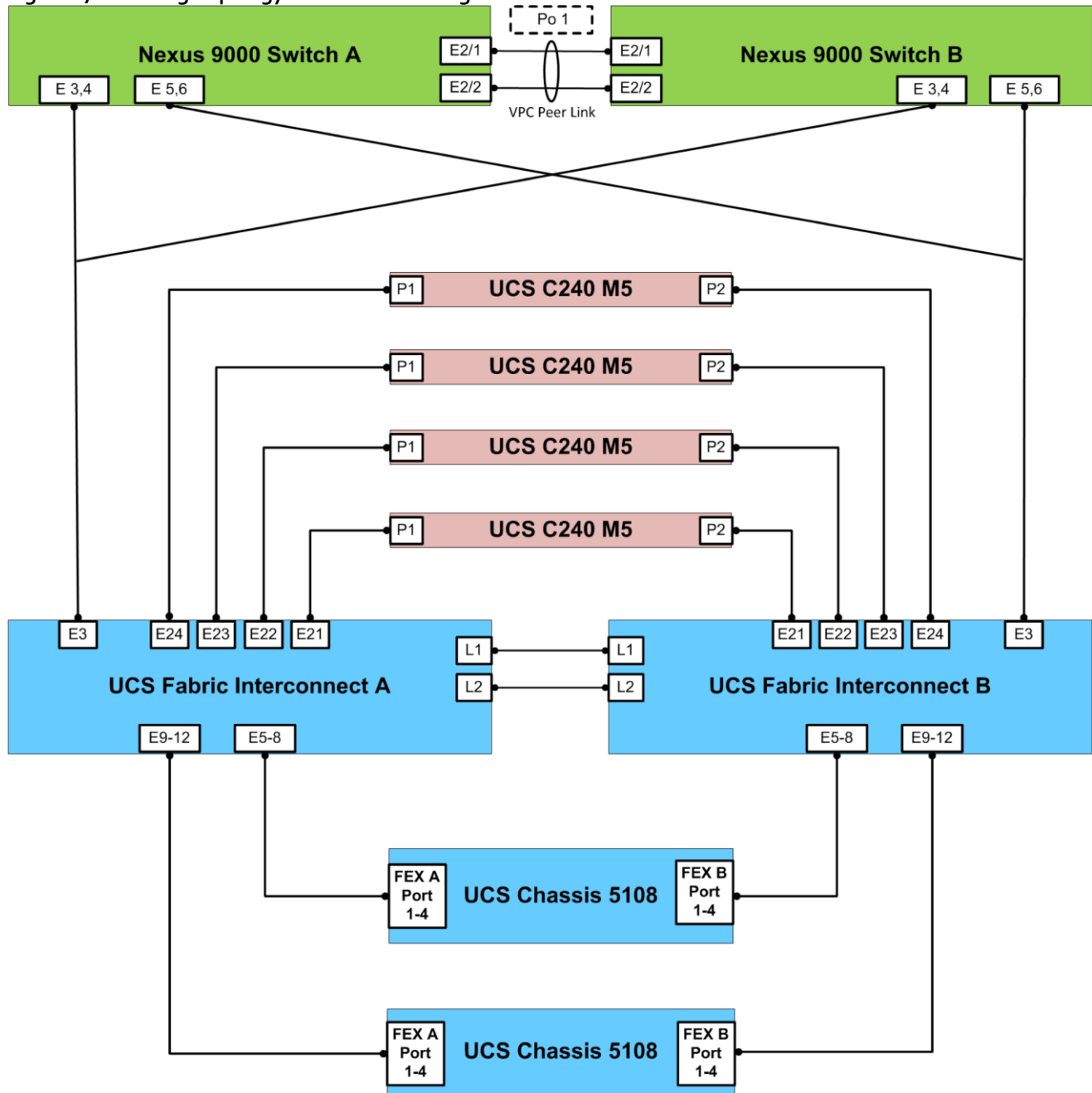

Figure 17 shows the cabling topology for Cisco UCS Integrated Infrastructure for SAP HANA configuration using the pair of Cisco Nexus 9000 series switches.

Figure 17 Cabling Topology for Cisco UCS Integrated Infrastructure for SAP HANA



### Physical Device Cabling

The information in this section is provided as a reference for cabling the network and compute components.

To simplify cabling requirements, the tables include both local and remote device and port locations. The following tables show the out-of-band management ports connectivity into preexisting management infrastructure, the Management Ports cabling needs to be adjusted accordingly. These Management interfaces will be used in various configuration steps.

Table 3 through O provides the details of all the connections.

**Table 3 Cisco UCS Fabric Interconnect A - Cabling Information for Cisco UCS B480-M5 Server(s) Option**

Local Device	Local Port	Connection	Remote Device	Remote Port
Cisco UCS fabric interconnect A	Eth1/1	40GbE	Uplink to Customer Data Switch A	Any
	Eth1/2	40GbE	Uplink to Customer Data Switch B	Any
	Eth1/3/1	40GbE QSFP to 4 SFP+ break-out cables	Cisco Nexus 3000 HA	Eth 1/3
	Eth1/3/2		Cisco Nexus 3000 HA	Eth 1/4
	Eth1/3/3		Cisco Nexus 3000 HA	Eth 1/5
	Eth1/3/4		Cisco Nexus 3000 HA	Eth 1/6
	Eth1/3/1*	40GbE QSFP to 4 SFP+ break-out cables	Cisco Nexus 9000 A	Eth 1/3
	Eth1/3/2*		Cisco Nexus 9000 A	Eth 1/4
	Eth1/3/3*		Cisco Nexus 9000 B	Eth 1/3
	Eth1/3/4*		Cisco Nexus 9000 B	Eth 1/4
	Eth1/4	40GbE		
	Eth1/5	40GbE	Cisco UCS Chassis 1 Fabric Extender (FEX) A	IOM 1/1
	Eth1/6	40GbE	Cisco UCS Chassis 1 Fabric Extender (FEX) A	IOM 1/2
	Eth1/7	40GbE	Cisco UCS Chassis 1 Fabric Extender (FEX) A	IOM 1/3
	Eth1/8	40GbE	Cisco UCS Chassis 1 Fabric Extender (FEX) A	IOM 1/4
	Eth1/9	40GbE	Cisco UCS Chassis 2 Fabric Extender (FEX) A	IOM 1/1
	Eth1/10	40GbE	Cisco UCS Chassis 2 Fabric Extender (FEX) A	IOM 1/2
	Eth1/11	40GbE	Cisco UCS Chassis 2 Fabric Extender (FEX) A	IOM 1/3
	Eth1/12	40GbE	Cisco UCS Chassis 2 Fabric Extender (FEX) A	IOM 1/4
	Eth1/13	40GbE	Cisco UCS Chassis 3 Fabric Extender (FEX) A	IOM 1/1
	Eth1/14	40GbE	Cisco UCS Chassis 3 Fabric Extender (FEX) A	IOM 1/2
	Eth1/15	40GbE	Cisco UCS Chassis 3 Fabric Extender (FEX) A	IOM 1/3
	Eth1/16	40GbE	Cisco UCS Chassis 3 Fabric Extender (FEX) A	IOM 1/4
	Eth1/17	40GbE	Cisco UCS Chassis 4 Fabric Extender (FEX) A	IOM 1/1
Eth1/18	40GbE	Cisco UCS Chassis 4 Fabric Extender (FEX) A	IOM 1/2	
Eth1/19	40GbE	Cisco UCS Chassis 4 Fabric Extender (FEX) A	IOM 1/3	
Eth1/20	40GbE	Cisco UCS Chassis 4 Fabric Extender (FEX) A	IOM 1/4	
Eth1/21	40GbE	Cisco UCS C240-M5-1	VIC 1385 Port 1	
Eth1/22	40GbE	Cisco UCS C240-M5-2	VIC 1385 Port 1	
Eth1/23	40GbE	Cisco UCS C240-M5-3	VIC 1385 Port 1	
Eth1/24	40GbE	Cisco UCS C240-M5-4	VIC 1385 Port 1	

Local Device	Local Port	Connection	Remote Device	Remote Port
	Eth1/25	40GbE	Cisco UCS C240-M5-5	VIC 1385 Port 1
	Eth1/26	40GbE	Cisco UCS C240-M5-6	VIC 1385 Port 1
	Eth1/27	40GbE	Cisco UCS C240-M5-7	VIC 1385 Port 1
	Eth1/28	40GbE	Cisco UCS C240-M5-8	VIC 1385 Port 1
	MGMT0	GbE	Customer's Management Switch	Any
	L1	GbE	Cisco UCS fabric interconnect B	L1
	L2	GbE	Cisco UCS fabric interconnect B	L2

\* The ports ETH1/3/1-4 are used with pair Nexus 9000 Switches design option.

**Table 4 Cisco UCS Fabric Interconnect B - Cabling Information for Cisco UCS B480 M5 Server(s) Option**

Local Device	Local Port	Connection	Remote Device	Remote Port
Cisco UCS fabric interconnect B	Eth1/1	40GbE	Uplink to Customer Data Switch A	Any
	Eth1/2	40GbE	Uplink to Customer Data Switch B	Any
	Eth1/3/1	40GbE QSFP to 4 SFP+ break-out cables	Cisco Nexus 3000 HA	Eth 1/7
	Eth1/3/2		Cisco Nexus 3000 HA	Eth 1/8
	Eth1/3/3		Cisco Nexus 3000 HA	Eth 1/9
	Eth1/3/4		Cisco Nexus 3000 HA	Eth 1/10
	Eth1/3/1*	40GbE QSFP to 4 SFP+ break-out cables	Cisco Nexus 9000 A	Eth 1/5
	Eth1/3/2*		Cisco Nexus 9000 A	Eth 1/6
	Eth1/3/3*		Cisco Nexus 9000 B	Eth 1/5
	Eth1/3/4*		Cisco Nexus 9000 B	Eth 1/6
	Eth1/4	40GbE		
	Eth1/5	40GbE	Cisco UCS Chassis 1 Fabric Extender (FEX) B	IOM 1/1
	Eth1/6	40GbE	Cisco UCS Chassis 1 Fabric Extender (FEX) B	IOM 1/2
	Eth1/7	40GbE	Cisco UCS Chassis 1 Fabric Extender (FEX) B	IOM 1/3
	Eth1/8	40GbE	Cisco UCS Chassis 1 Fabric Extender (FEX) B	IOM 1/4
	Eth1/9	40GbE	Cisco UCS Chassis 2 Fabric Extender (FEX) B	IOM 1/1
	Eth1/10	40GbE	Cisco UCS Chassis 2 Fabric Extender (FEX) B	IOM 1/2
	Eth1/11	40GbE	Cisco UCS Chassis 2 Fabric Extender (FEX) B	IOM 1/3
	Eth1/12	40GbE	Cisco UCS Chassis 2 Fabric Extender (FEX) B	IOM 1/4
	Eth1/13	40GbE	Cisco UCS Chassis 3 Fabric Extender (FEX) B	IOM 1/1
Eth1/14	40GbE	Cisco UCS Chassis 3 Fabric Extender (FEX) B	IOM 1/2	

Local Device	Local Port	Connection	Remote Device	Remote Port
	Eth1/15	40GbE	Cisco UCS Chassis 3 Fabric Extender (FEX) B	IOM 1/3
	Eth1/16	40GbE	Cisco UCS Chassis 3 Fabric Extender (FEX) B	IOM 1/4
	Eth1/17	40GbE	Cisco UCS Chassis 4 Fabric Extender (FEX) B	IOM 1/1
	Eth1/18	40GbE	Cisco UCS Chassis 4 Fabric Extender (FEX) B	IOM 1/2
	Eth1/19	40GbE	Cisco UCS Chassis 4 Fabric Extender (FEX) B	IOM 1/3
	Eth1/20	40GbE	Cisco UCS Chassis 4 Fabric Extender (FEX) B	IOM 1/4
	Eth1/21	40GbE	Cisco UCS C240-M5-1	VIC 1385 Port 2
	Eth1/22	40GbE	Cisco UCS C240-M5-2	VIC 1385 Port 2
	Eth1/23	40GbE	Cisco UCS C240-M5-3	VIC 1385 Port 2
	Eth1/24	40GbE	Cisco UCS C240-M5-4	VIC 1385 Port 2
	Eth1/25	40GbE	Cisco UCS C240-M5-5	VIC 1385 Port 2
	Eth1/26	40GbE	Cisco UCS C240-M5-6	VIC 1385 Port 2
	Eth1/27	40GbE	Cisco UCS C240-M5-7	VIC 1385 Port 2
	Eth1/28	40GbE	Cisco UCS C240-M5-8	VIC 1385 Port 2
	MGMT0	GbE	Customer's Management Switch	Any
	L1	GbE	Cisco UCS fabric interconnect A	L1
	L2	GbE	Cisco UCS fabric interconnect A	L2

\* The ports ETH1/3/1-4 are used with pair Nexus 9000 Switches design option.

**Table 5 Cisco UCS Fabric Interconnect A - Cabling Information for Cisco UCS C480 M5 Server(s) Option**

Local Device	Local Port	Connection	Remote Device	Remote Port
Cisco UCS fabric interconnect A	Eth1/1	40GbE	Uplink to Customer Data Switch A	Any
	Eth1/2	40GbE	Uplink to Customer Data Switch B	Any
	Eth1/3/1	40GbE	Cisco Nexus 3000 HA	Eth 1/3
	Eth1/3/2	QSFP to 4 SFP+ break-out cables	Cisco Nexus 3000 HA	Eth 1/4
	Eth1/3/3		Cisco Nexus 3000 HA	Eth 1/5
	Eth1/3/4		Cisco Nexus 3000 HA	Eth 1/6
	Eth1/3/1*		40GbE	Cisco Nexus 9000 A
	Eth1/3/2*	QSFP to 4 SFP+ break-out cables	Cisco Nexus 9000 A	Eth 1/4
	Eth1/3/3*		Cisco Nexus 9000 B	Eth 1/3
	Eth1/3/4*		Cisco Nexus 9000 B	Eth 1/4
	Eth1/4		40GbE	
	Eth1/5	40GbE	Cisco UCS C480-M5-1	VIC 1385 Port 1

Local Device	Local Port	Connection	Remote Device	Remote Port
	Eth1/6	40GbE	Cisco UCS C480-M5-2	VIC 1385 Port 1
	Eth1/7	40GbE	Cisco UCS C480-M5-3	VIC 1385 Port 1
	Eth1/8	40GbE	Cisco UCS C480-M5-4	VIC 1385 Port 1
	Eth1/9	40GbE	Cisco UCS C480-M5-5	VIC 1385 Port 1
	Eth1/10	40GbE	Cisco UCS C480-M5-6	VIC 1385 Port 1
	Eth1/11	40GbE	Cisco UCS C480-M5-7	VIC 1385 Port 1
	Eth1/12	40GbE	Cisco UCS C480-M5-8	VIC 1385 Port 1
	Eth1/13	40GbE	Cisco UCS C480-M5-9	VIC 1385 Port 1
	Eth1/14	40GbE	Cisco UCS C480-M5-10	VIC 1385 Port 1
	Eth1/15	40GbE	Cisco UCS C480-M5-11	VIC 1385 Port 1
	Eth1/16	40GbE	Cisco UCS C480-M5-12	VIC 1385 Port 1
	Eth1/17	40GbE	Cisco UCS C480-M5-13	VIC 1385 Port 1
	Eth1/18	40GbE	Cisco UCS C480-M5-14	VIC 1385 Port 1
	Eth1/19	40GbE	Cisco UCS C480-M5-15	VIC 1385 Port 1
	Eth1/20	40GbE	Cisco UCS C480-M5-16	VIC 1385 Port 1
	Eth1/21	40GbE	Cisco UCS C240-M5-1	VIC 1385 Port 1
	Eth1/22	40GbE	Cisco UCS C240-M5-2	VIC 1385 Port 1
	Eth1/23	40GbE	Cisco UCS C240-M5-3	VIC 1385 Port 1
	Eth1/24	40GbE	Cisco UCS C240-M5-4	VIC 1385 Port 1
	Eth1/25	40GbE	Cisco UCS C240-M5-5	VIC 1385 Port 1
	Eth1/26	40GbE	Cisco UCS C240-M5-6	VIC 1385 Port 1
	Eth1/27	40GbE	Cisco UCS C240-M5-7	VIC 1385 Port 1
	Eth1/28	40GbE	Cisco UCS C240-M5-8	VIC 1385 Port 1
	MGMT0	GbE	Customer's Management Switch	Any
	L1	GbE	Cisco UCS fabric interconnect B	L1
	L2	GbE	Cisco UCS fabric interconnect B	L2

\* The ports ETH1/3/1-4 are used with pair Nexus 9000 Switches design option.

**Table 6 Cisco UCS Fabric Interconnect B - Cabling Information for Cisco UCS C480 M5 Server(s) Option**

Local Device	Local Port	Connection	Remote Device	Remote Port
Cisco UCS fabric interconnect B	Eth1/1	40GbE	Uplink to Customer Data Switch A	Any
	Eth1/2	40GbE	Uplink to Customer Data Switch B	Any
	Eth1/3/1	40GbE	Cisco Nexus 3000 HA	Eth 1/7

Local Device	Local Port	Connection	Remote Device	Remote Port
	Eth1/3/2	QSFP to 4 SFP+ break-out cables	Cisco Nexus 3000 HA	Eth 1/8
	Eth1/3/3		Cisco Nexus 3000 HA	Eth 1/9
	Eth1/3/4		Cisco Nexus 3000 HA	Eth 1/10
	Eth1/3/1*	40GbE QSFP to 4 SFP+ break-out cables	Cisco Nexus 9000 A	Eth 1/5
	Eth1/3/2*		Cisco Nexus 9000 A	Eth 1/6
	Eth1/3/3*		Cisco Nexus 9000 B	Eth 1/5
	Eth1/3/4*		Cisco Nexus 9000 B	Eth 1/6
	Eth1/4	40GbE		
	Eth1/5	40GbE	Cisco UCS C480-M5-1	VIC 1385 Port 2
	Eth1/6	40GbE	Cisco UCS C480-M5-2	VIC 1385 Port 2
	Eth1/7	40GbE	Cisco UCS C480-M5-3	VIC 1385 Port 2
	Eth1/8	40GbE	Cisco UCS C480-M5-4	VIC 1385 Port 2
	Eth1/9	40GbE	Cisco UCS C480-M5-5	VIC 1385 Port 2
	Eth1/10	40GbE	Cisco UCS C480-M5-6	VIC 1385 Port 2
	Eth1/11	40GbE	Cisco UCS C480-M5-7	VIC 1385 Port 2
	Eth1/12	40GbE	Cisco UCS C480-M5-8	VIC 1385 Port 2
	Eth1/13	40GbE	Cisco UCS C480-M5-9	VIC 1385 Port 2
	Eth1/14	40GbE	Cisco UCS C480-M5-10	VIC 1385 Port 2
	Eth1/15	40GbE	Cisco UCS C480-M5-11	VIC 1385 Port 2
	Eth1/16	40GbE	Cisco UCS C480-M5-12	VIC 1385 Port 2
	Eth1/17	40GbE	Cisco UCS C480-M5-13	VIC 1385 Port 2
	Eth1/18	40GbE	Cisco UCS C480-M5-14	VIC 1385 Port 2
	Eth1/19	40GbE	Cisco UCS C480-M5-15	VIC 1385 Port 2
	Eth1/20	40GbE	Cisco UCS C480-M5-16	VIC 1385 Port 2
	Eth1/21	40GbE	Cisco UCS C240-M5-1	VIC 1385 Port 2
	Eth1/22	40GbE	Cisco UCS C240-M5-2	VIC 1385 Port 2
	Eth1/23	40GbE	Cisco UCS C240-M5-3	VIC 1385 Port 2
	Eth1/24	40GbE	Cisco UCS C240-M5-4	VIC 1385 Port 2
	Eth1/25	40GbE	Cisco UCS C240-M5-5	VIC 1385 Port 2
	Eth1/26	40GbE	Cisco UCS C240-M5-6	VIC 1385 Port 2
	Eth1/27	40GbE	Cisco UCS C240-M5-7	VIC 1385 Port 2
	Eth1/28	40GbE	Cisco UCS C240-M5-8	VIC 1385 Port 2



Local Device	Local Port	Connection	Remote Device	Remote Port
	MGMT0	GbE	Customer's Management Switch	Any
	L1	GbE	Cisco UCS fabric interconnect A	L1
	L2	GbE	Cisco UCS fabric interconnect A	L2

\* The ports ETH1/3/1-4 are used with pair Nexus 9000 Switches design option.

**Table 7 Cisco Nexus 3000 Cabling Information**

Local Device	Local Port	Connection	Remote Device	Remote Port
Cisco Nexus 3000 HA	Eth1/3	10GbE	Cisco UCS fabric interconnect A	Eth1/3/1
	Eth1/4	10GbE	Cisco UCS fabric interconnect A	Eth1/3/2
	Eth1/5	10GbE	Cisco UCS fabric interconnect A	Eth1/3/3
	Eth1/6	10GbE	Cisco UCS fabric interconnect A	Eth1/3/4
	Eth1/7	10GbE	Cisco UCS fabric interconnect B	Eth1/3/1
	Eth1/8	10GbE	Cisco UCS fabric interconnect B	Eth1/3/2
	Eth1/9	10GbE	Cisco UCS fabric interconnect B	Eth1/3/3
	Eth1/10	10GbE	Cisco UCS fabric interconnect B	Eth1/3/4
	MGMT0	GbE	Customer's Management Switch	Any

**Table 8 Cisco Nexus 9000-A Cabling Information**

Local Device	Local Port	Connection	Remote Device	Remote Port
Cisco Nexus 9000 A	Eth1/1	10GbE	Uplink to Customer Data Switch A	Any
	Eth1/2	10GbE	Uplink to Customer Data Switch B	Any
	Eth1/3	10GbE	Cisco UCS fabric interconnect A	Eth1/3/1
	Eth1/4	10GbE	Cisco UCS fabric interconnect A	Eth1/3/2
	Eth1/5	10GbE	Cisco UCS fabric interconnect B	Eth1/3/1
	Eth1/6	10GbE	Cisco UCS fabric interconnect B	Eth1/3/2
	Eth1/9*	10GbE	Cisco Nexus 9000 B	Eth1/9
	Eth1/10*	10GbE	Cisco Nexus 9000 B	Eth1/10
	Eth1/11*	10GbE	Cisco Nexus 9000 B	Eth1/11
	Eth1/12*	10GbE	Cisco Nexus 9000 B	Eth1/12
	MGMT0	GbE	Customer's Management Switch	Any

\* The ports ETH1/9-12 can be replaced with E2/1 and E2/2 for 40G connectivity.



For devices requiring GbE connectivity, use the GbE Copper SFP+s (GLC-T=).

**Table 9 Cisco Nexus 9000-B Cabling Information**

Local Device	Local Port	Connection	Remote Device	Remote Port
Cisco Nexus 9000 B	Eth1/1	10GbE	Uplink to Customer Data Switch A	Any
	Eth1/2	10GbE	Uplink to Customer Data Switch B	Any
	Eth1/3	10GbE	Cisco UCS fabric interconnect A	Eth1/3/3
	Eth1/4	10GbE	Cisco UCS fabric interconnect A	Eth1/3/4
	Eth1/5	10GbE	Cisco UCS fabric interconnect B	Eth1/3/3
	Eth1/6	10GbE	Cisco UCS fabric interconnect B	Eth1/3/4
	Eth1/9*	10GbE	Cisco Nexus 9000 A	Eth1/9
	Eth1/10*	10GbE	Cisco Nexus 9000 A	Eth1/10
	Eth1/11*	10GbE	Cisco Nexus 9000 A	Eth1/11
	Eth1/12*	10GbE	Cisco Nexus 9000 A	Eth1/12
	MGMT0	GbE	Customer's Management Switch	Any

\* The ports ETH1/9-12 can be replaced with E2/1 and E2/2 for 40G connectivity.



For devices requiring GbE connectivity, use the GbE Copper SFP+s (GLC-T=).

## Software Revisions

Table 10 details the software revisions used for validating various components of the Cisco UCS B/C480 M5 Scale-Out for SAP HANA.

**Table 10 Hardware and Software Components of the Cisco UCS B/C480 M5 Scale-Out for SAP HANA**

Vendor	Product	Version	Description
Cisco	Cisco UCSM	3.2(2d)	Cisco UCS Manager
Cisco	Cisco UCS 6332 UP FI	5.0(3)N2(3.22c)	Cisco UCS Fabric Interconnects
Cisco	Cisco UCS 5108 Blade Chassis	NA	Cisco UCS Blade Server Chassis
Cisco	Cisco UCS 2304 XP FEX	3.2(2c)	Cisco UCS Fabric Extenders for Blade Server chassis
Cisco	Cisco UCS B-Series M5 Servers	3.1(25d)	Cisco B-Series M5 Blade Servers
Cisco	Cisco UCS C-Series M5 Servers	3.1(2d) – CIMC Controller	Cisco C-Series M5 Blade Servers
Cisco	Cisco UCS C240 M5	3.1(2d) – CIMC Controller	Cisco C240 M5 Rack Servers

Vendor	Product	Version	Description
	Servers		for Management
Cisco	Cisco UCS VIC 1340/1380	4.2(2b)	Cisco UCS VIC 1240/1280 Adapters
Cisco	Cisco UCS VIC 1385	4.2(2b)	Cisco UCS VIC Adapter
Cisco	Cisco Nexus 9372PX Switches	7.0(3)I4(7)	Cisco Nexus 9372PX Switches
Cisco	Cisco Nexus 3524 Switches	7.0(3)I4(7)	Cisco Nexus N3K-C3524P Switch
SUSE	SLES 12 / SLES for SAP Applications 12	12 SP2 (64 bit)	Operating System to host SAP HANA
MapR	MapR Converged Enterprise Edition	6.0.0.20171109191718.GA	MapR Converged Enterprise Edition

## Network Configuration

The following section provides a detailed procedure for configuring the Cisco Nexus 3524 Switch for High Availability in the SAP HANA environment. The switch configuration in this section is based on the cabling plan described in the Device Cabling section. If the systems are connected on different ports, configure the switches accordingly by following the guidelines described below.

### Cisco Nexus 3500 Series Switch Network Configuration

These steps provide the details for the initial Cisco Nexus 3524 Series Switch setup.

#### Cisco Nexus 3524 Initial Configuration

To set up the initial configuration for the first Cisco Nexus switch, complete the following steps:



On initial boot and connection to the serial or console port of the switch, the NX-OS setup should automatically start and attempt to enter Power on Auto Provisioning.

```
Abort Power On Auto Provisioning and continue with normal setup ?(yes/no) [n]:yes
```

```
---- System Admin Account Setup ----
```

```
Do you want to enforce secure password standard (yes/no): yes
```

```
Enter the password for "admin":
Confirm the password for "admin":
```

```
---- Basic System Configuration Dialog ----
```

```
This setup utility will guide you through the basic configuration of
the system. Setup configures only enough connectivity for management
of the system.
```

```
Please register Cisco Nexus 3500 Family devices promptly with your
supplier. Failure to register may affect response times for initial
service calls. Nexus devices must be registered to receive entitled
support services.
```

```
Press Enter at anytime to skip a dialog. Use ctrl-c at anytime
to skip the remaining dialogs.
```

```
Would you like to enter the basic configuration dialog (yes/no): yes
```

```
Create another login account (yes/no) [n]:
```

```
Configure read-only SNMP community string (yes/no) [n]:
```

```
Configure read-write SNMP community string (yes/no) [n]:
```

```
Enter the switch name : <<var_nexus_HA_hostname>>
```

```
Continue with Out-of-band (mgmt0) management configuration? (yes/no) [y]:
```

```
Mgmt0 IPv4 address : <<var_nexus_HA_mgmt0_ip>>
```

```
Mgmt0 IPv4 netmask : <<var_nexus_HA_mgmt0_netmask>>
```

```
Configure the default gateway? (yes/no) [y]:
```

```

IPv4 address of the default gateway : <<var_nexus_HA_mgmt0_gw>>
Enable the telnet service? (yes/no) [n]:
Enable the ssh service? (yes/no) [y]:
Type of ssh key you would like to generate (dsa/rsa) : rsa
Number of key bits <768-2048> : 2048
Configure the ntp server? (yes/no) [n]: y
NTP server IPv4 address : <<var_global_ntp_server_ip>>
Configure default interface layer (L3/L2) [L2]:
Configure default switchport interface state (shut/noshut) [noshut]:
Configure CoPP System Policy Profile ( default / 12 / 13 ) [default]:

The following configuration will be applied:
switchname <<var_nexus_HA_hostname>>
interface mgmt0
ip address <<var_nexus_HA_mgmt0_ip>> <<var_nexus_HA_mgmt0_netmask>>
vrf context management
ip route 0.0.0.0/0 <<var_nexus_A_mgmt0_gw>>
no shutdown
no telnet server enable
ssh key rsa 2048 force
ssh server enable
ntp server <<var_global_ntp_server_ip>>
system default switchport
no system default switchport shutdown
policy-map type control-plane copp-system-policy ( default )

Would you like to edit the configuration? (yes/no) [n]:

Use this configuration and save it? (yes/no) [y]:

[#####] 100%
Copy complete, now saving to disk (please wait)...

```

## Enable Appropriate Cisco Nexus 3524 Switch Features and Settings

The following commands enable IP switching feature and set default spanning tree behaviors:

1. On each Nexus 3524, enter configuration mode:

```
config terminal
```

2. Use the following commands to enable the necessary features:

```
feature lacp
feature interface-vlan
feature lldp
```

3. Save the running configuration to start-up:

```
copy run start
```

## Create Global Policy to Enable Jumbo Frame and Apply the Policy to System Wide

```
policy-map type network-qos jumbo
```

```

class type network-qos class-default

    mtu 9216

system qos
    service-policy type network-qos jumbo

```

## Create VLANs for SAP HANA Traffic

To create the necessary VLANs, complete the following step on both switches:

1. From the configuration mode, run the following commands:

```

vlan <<var_storage_vlan_id>>
name HANA-Storage

vlan <<var_internal_vlan_id>>
name HANA-Internal

vlan <<var_inband_vlan_id>>
name NFS-IPMI

vlan <<var_mapr-01_vlan_id>>
name MapR-01

vlan <<var_mapr-02_vlan_id>>
name MapR-02

vlan <<var_mapr-03_vlan_id>>
name MapR-03

```

## Configure Network Interfaces Connecting to Cisco UCS Fabric Interconnect

1. Define a port description for the interface connecting to <<var\_ucs\_clustername>>-A.

```

interface Eth1/3-6
description <<var_ucs_clustername>>-A:1/3

```

2. Apply it to a port channel and bring up the interface.

```

interface eth1/3-6
channel-group 3 mode active
no shutdown

```

3. Define a description for the port channel connecting to <<var\_ucs\_clustername>>-A.

```

interface Po3
description <<var_ucs_clustername>>-A

```

4. Make the port channel a switchport, and configure a trunk to allow internal HANA VLANs.

```

switchport
switchport mode trunk
switchport trunk allowed vlan <<var_storage_vlan_id>>,<<var_internal_vlan_id>>,<<var_inband_vlan_id>>,
<<var_mapr-01_vlan_id>>,<<var_mapr-02_vlan_id>>,<<var_mapr-03_vlan_id>>

```

5. Make the port channel and associated interfaces spanning tree edge ports.

```

spanning-tree port type edge trunk
spanning-tree bpduguard enable

```

6. Bring up the port-channel.

```
no shutdown
```

7. Define a port description for the interface connecting to <<var\_ucs\_clustername>>-B.

```
interface Eth1/7-10
description <<var_ucs_clustername>>-B:1/3
```

8. Apply it to a port channel and bring up the interface.

```
interface Eth1/7-10
channel-group 4 mode active
no shutdown
```

9. Define a description for the port-channel connecting to <<var\_ucs\_clustername>>-B.

```
interface Po4
description <<var_ucs_clustername>>-B
```

10. Make the port-channel a switchport, and configure a trunk to allow internal HANA VLANs.

```
switchport
switchport mode trunk
switchport trunk allowed vlan <<var_storage_vlan_id>>,<<var_internal_vlan_id>>,<<var_inband_vlan_id>>,
<<var_mapr-01_vlan_id>>,<<var_mapr-02_vlan_id>>,<<var_mapr-03_vlan_id>>
```

11. Make the port channel and associated interfaces spanning tree edge ports.

```
spanning-tree port type edge trunk
spanning-tree bpduguard enable
```

12. Bring up the port channel.

```
no shutdown
```

13. Save the running configuration to start-up configuration.

```
copy run start
```

## Cisco Nexus 9000 Series Switch Network Configuration

The following section provides a detailed procedure for configuring the Cisco Nexus 9000 Switches for SAP HANA environment. The switch configuration in this section based on cabling plan described in the Device Cabling section. If the systems connected on different ports, configure the switches accordingly following the guidelines described in this section.



The configuration steps detailed in this section provides guidance for configuring the Cisco Nexus 9000 running release 7.0(3)I5(1) within a multi-VDC environment.

These steps provide the details for the initial Cisco Nexus 9000 Series Switch setup.

### Cisco Nexus 9000 A Initial Configuration

To set up the initial configuration for the first Cisco Nexus switch, complete the following steps:



On initial boot and connection to the serial or console port of the switch, the NX-OS setup should automatically start and attempt to enter Power on Auto Provisioning.



---- Basic System Configuration Dialog VDC: 1 ----

This setup utility will guide you through the basic configuration of the system. Setup configures only enough connectivity for management of the system.

\*Note: setup is mainly used for configuring the system initially, when no configuration is present. So setup always assumes system defaults and not the current system configuration values.

Press Enter at anytime to skip a dialog. Use ctrl-c at anytime to skip the remaining dialogs.

Would you like to enter the basic configuration dialog (yes/no): yes

Do you want to enforce secure password standard (yes/no) [y]:

Create another login account (yes/no) [n]:

Configure read-only SNMP community string (yes/no) [n]:

Configure read-write SNMP community string (yes/no) [n]:

Enter the switch name : <<var\_nexus\_A\_hostname>>

Continue with Out-of-band (mgmt0) management configuration? (yes/no) [y]:

Mgmt0 IPv4 address : <<var\_nexus\_A\_mgmt0\_ip>>

Mgmt0 IPv4 netmask : <<var\_nexus\_A\_mgmt0\_netmask>>

Configure the default gateway? (yes/no) [y]:

IPv4 address of the default gateway : <<var\_nexus\_A\_mgmt0\_gw>>

Configure advanced IP options? (yes/no) [n]:

Enable the telnet service? (yes/no) [n]:

Enable the ssh service? (yes/no) [y]:

Type of ssh key you would like to generate (dsa/rsa) [rsa]:

Number of rsa key bits <1024-2048> [2048]:

Configure the ntp server? (yes/no) [n]: y

NTP server IPv4 address : <<var\_global\_ntp\_server\_ip>>

Configure CoPP system profile (strict/moderate/lenient/dense/skip) [strict]:

The following configuration will be applied:

```
password strength-check
switchname <<var_nexus_A_hostname>>
vrf context management
ip route 0.0.0.0/0 <<var_nexus_A_mgmt0_gw>>
exit
no feature telnet
ssh key rsa 2048 force
feature ssh
ntp server <<var_global_ntp_server_ip>>
copp profile strict
interface mgmt0
ip address <<var_nexus_A_mgmt0_ip>> <<var_nexus_A_mgmt0_netmask>>
no shutdown
```

Would you like to edit the configuration? (yes/no) [n]: Enter

Use this configuration and save it? (yes/no) [y]: Enter

[#####] 100%

```
Copy complete.
```

## Cisco Nexus 9000 B Initial Configuration

To set up the initial configuration for the second Cisco Nexus switch complete the following steps:



On initial boot and connection to the serial or console port of the switch, the NX-OS setup should automatically start and attempt to enter Power on Auto Provisioning.

```

---- Basic System Configuration Dialog VDC: 1 ----

This setup utility will guide you through the basic configuration of
the system. Setup configures only enough connectivity for management
of the system.

*Note: setup is mainly used for configuring the system initially,
when no configuration is present. So setup always assumes system
defaults and not the current system configuration values.

Press Enter at anytime to skip a dialog. Use ctrl-c at anytime
to skip the remaining dialogs.

Would you like to enter the basic configuration dialog (yes/no): yes

Create another login account (yes/no) [n]:

Configure read-only SNMP community string (yes/no) [n]:

Configure read-write SNMP community string (yes/no) [n]:

Enter the switch name : <<var_nexus_B_hostname>>

Continue with Out-of-band (mgmt0) management configuration? (yes/no) [y]:

Mgmt0 IPv4 address : <<var_nexus_B_mgmt0_ip>>

Mgmt0 IPv4 netmask : <<var_nexus_B_mgmt0_netmask>>

Configure the default gateway? (yes/no) [y]:

IPv4 address of the default gateway : <<var_nexus_B_mgmt0_gw>>

Configure advanced IP options? (yes/no) [n]:

Enable the telnet service? (yes/no) [n]:

Enable the ssh service? (yes/no) [y]:

Type of ssh key you would like to generate (dsa/rsa) [rsa]:

Number of rsa key bits <1024-2048> [2048]:

Configure the ntp server? (yes/no) [n]:  y

NTP server IPv4 address : <<var_global_ntp_server_ip>>

Configure default interface layer (L3/L2) [L3]: L2

Configure default switchport interface state (shut/noshut) [shut]:  Enter

Configure CoPP system profile (strict/moderate/lenient/dense/skip) [strict]:

The following configuration will be applied:
password strength-check
switchname <<var_nexus_B_hostname>>
vrf context management
ip route 0.0.0.0/0 <<var_nexus_B_mgmt0_gw>>

```

```

exit
no feature telnet
ssh key rsa 2048 force
feature ssh
ntp server <<var_global_ntp_server_ip>>
copp profile strict
interface mgmt0
ip address <<var_nexus_B_mgmt0_ip>> <<var_nexus_B_mgmt0_netmask>>
no shutdown

Would you like to edit the configuration? (yes/no) [n]:  Enter

Use this configuration and save it? (yes/no) [y]:  Enter

[#####] 100%
Copy complete.

```

## Enable Appropriate Cisco Nexus 9000 Series Switches—Features and Settings

### Cisco Nexus 9000 A and Cisco Nexus 9000 B

The following commands enable the IP switching feature and set the default spanning tree behaviors:

1. On each Nexus 9000, enter configuration mode:

```
config terminal
```

2. Use the following commands to enable the necessary features:

```

feature udld
feature lacp
feature vpc
feature interface-vlan
feature lldp

```

3. Configure spanning tree defaults:

```

spanning-tree port type network default
spanning-tree port type edge bpduguard default
spanning-tree port type edge bpdufilter default

```

4. Save the running configuration to start-up:

```
copy run start
```

## Create VLANs for SAP HANA Traffic

### Cisco Nexus 9000 A and Cisco Nexus 9000 B

To create the necessary VLANs, complete the following step on both switches:

1. From the configuration mode, run the following commands:

```

vlan <<var_storage_vlan_id>>
name HANA-Storage

vlan <<var_mgmt_vlan_id>>
name Management

vlan <<var_internal_vlan_id>>
name HANA-Internal

vlan <<var_backup_vlan_id>>

```

```

name HANA-Backup

vlan <<var_client_vlan_id>>
name HANA-Client

vlan <<var_appserver_vlan_id>>
name HANA-AppServer

vlan <<var_datasource_vlan_id>>
name HANA-DataSource

vlan <<var_replication_vlan_id>>
name HANA-Replication

vlan <<var_inband_vlan_id>>
name NFS-IPMI

vlan <<var_mapr-01_vlan_id>>
name MapR-01

vlan <<var_mapr-02_vlan_id>>
name MapR-02

vlan <<var_mapr-03_vlan_id>>
name MapR-03

```

## Configure Virtual Port-Channel Domain

### Cisco Nexus 9000 A

To configure vPCs for switch A, complete the following steps:

1. From the global configuration mode, create a new vPC domain:

```
vpc domain <<var_nexus_vpc_domain_id>>
```

2. Make Nexus 9000A the primary vPC peer by defining a low priority value:

```
role priority 10
```

3. Use the management interfaces on the supervisors of the Nexus 9000s to establish a keepalive link:

```
peer-keepalive destination <<var_nexus_B_mgmt0_ip>> source <<var_nexus_A_mgmt0_ip>>
```

4. Enable following features for this vPC domain:

```

peer-switch
delay restore 150
peer-gateway
auto-recovery

```

### Cisco Nexus 9000 B

To configure vPCs for switch B, complete the following steps:

1. From the global configuration mode, create a new vPC domain:

```
vpc domain <<var_nexus_vpc_domain_id>>
```

2. Make Cisco Nexus 9000 B the secondary vPC peer by defining a higher priority value than that of the Nexus 9000 A:

```
role priority 20
```

3. Use the management interfaces on the supervisors of the Cisco Nexus 9000s to establish a keepalive link:

```
peer-keepalive destination <<var_nexus_A_mgmt0_ip>> source <<var_nexus_B_mgmt0_ip>>
```

4. Enable following features for this vPC domain:

```
peer-switch
delay restore 150
peer-gateway
auto-recovery
```

## Configure Network Interfaces for the VPC Peer Links

### Cisco Nexus 9000 A

1. Define a port description for the interfaces connecting to VPC Peer <<var\_nexus\_B\_hostname>>.

```
interface Eth2/1
description VPC Peer <<var_nexus_B_hostname>>:2/1

interface Eth2/2
description VPC Peer <<var_nexus_B_hostname>>:2/2
```

2. Apply a port channel to both VPC Peer links and bring up the interfaces.

```
interface Eth2/1-2
channel-group 1 mode active
no shutdown
```

3. Define a description for the port-channel connecting to <<var\_nexus\_B\_hostname>>.

```
interface Po1
description vPC peer-link
```

4. Make the port channel a switchport, and configure a trunk to allow HANA VLANs.

```
switchport
switchport mode trunk
switchport trunk allowed vlan
<<var_storage_vlan_id>>,<<var_mgmt_vlan_id>>,<<var_boot_vlan_id>>,<<var_internal_vlan_id>>,<<var_inband_vlan_
id>>,<<var_backup_vlan_id>>, <<var_client_vlan_id>>, <<var_appserver_vlan_id>>, <<var_datasource_vlan_id>>,
<<var_replication_vlan_id>>
```

5. Make this port-channel the VPC peer link and bring it up.

```
spanning-tree port type network
vpc peer-link
no shutdown
```

### Cisco Nexus 9000 B

1. Define a port description for the interfaces connecting to VPC peer <<var\_nexus\_A\_hostname>>.

```
interface Eth2/1
description VPC Peer <<var_nexus_A_hostname>>:2/1

interface Eth2/2
description VPC Peer <<var_nexus_A_hostname>>:2/2
```

2. Apply a port channel to both VPC peer links and bring up the interfaces.

```
interface Eth2/1-2
channel-group 1 mode active
no shutdown
```

3. Define a description for the port-channel connecting to <<var\_nexus\_A\_hostname>>.

```
interface Po1
description vPC peer-link
```

4. Make the port-channel a switchport, and configure a trunk to allow HANA VLANs.

```
switchport
switchport mode trunk
switchport trunk allowed vlan
<<var_storage_vlan_id>>,<<var_mgmt_vlan_id>>,<<var_boot_vlan_id>>,<<var_internal_vlan_id>>,<<var_inband_vlan_
id>>,<<var_backup_vlan_id>>, <<var_client_vlan_id>>, <<var_appserver_vlan_id>>, <<var_datasource_vlan_id>>,
<<var_replication_vlan_id>>
```

5. Make this port-channel the VPC peer link and bring it up.

```
spanning-tree port type network
vpc peer-link
no shutdown
```

## Configure Network Interfaces with Cisco UCS Fabric Interconnect

### Cisco Nexus 9000 A and Cisco Nexus 9000 B

1. Define a port description for the interface connecting to <<var\_ucs\_clustername>>-A.

```
interface Eth1/3-4
description <<var_ucs_clustername>>-A:1/3
```

2. Apply it to a port channel and bring up the interface.

```
interface eth1/3-4
channel-group 11 mode active
no shutdown
```

3. Define a description for the port-channel connecting to <<var\_ucs\_clustername>>-A.

```
interface Po11
description <<var_ucs_clustername>>-A
```

4. Make the port-channel a switchport, and configure a trunk to allow all HANA VLANs.

```
switchport
switchport mode trunk
switchport trunk allowed vlan
<<var_storage_vlan_id>>,<<var_mgmt_vlan_id>>,<<var_boot_vlan_id>>,<<var_internal_vlan_id>>,<<var_inband_vlan_
id>>,<<var_backup_vlan_id>>, <<var_client_vlan_id>>, <<var_appserver_vlan_id>>, <<var_datasource_vlan_id>>,
<<var_replication_vlan_id>>
```

5. Make the port channel and associated interfaces spanning tree edge ports.

```
spanning-tree port type edge trunk
```

6. Set the MTU to be 9216 to support jumbo frames.

```
mtu 9216
```

7. Make this a VPC port-channel and bring it up.

```
vpc 11
no shutdown
```

8. Define a port description for the interface connecting to <<var\_ucs\_clustername>>-B.

```
interface Eth1/5-6
description <<var_ucs_clustername>>-B:1/3
```

9. Apply it to a port channel and bring up the interface.

```
interface Eth1/5-6
channel-group 12 mode active
no shutdown
```

10. Define a description for the port-channel connecting to <<var\_ucs\_clustername>>-B.

```
interface Po12
description <<var_ucs_clustername>>-B
```

11. Make the port-channel a switchport, and configure a trunk to allow all HANA VLANs.

```
switchport
switchport mode trunk
switchport trunk allowed vlan
<<var_storage_vlan_id>>,<<var_mgmt_vlan_id>>,<<var_boot_vlan_id>>,<<var_internal_vlan_id>>,<<var_inband_vlan_
id>>,<<var_backup_vlan_id>>, <<var_client_vlan_id>>, <<var_appserver_vlan_id>>, <<var_datasource_vlan_id>>,
<<var_replication_vlan_id>>
```

12. Make the port channel and associated interfaces spanning tree edge ports.

```
spanning-tree port type edge trunk
```

13. 53. Set the MTU to be 9216 to support jumbo frames.

```
mtu 9216
```

14. Make this a VPC port-channel and bring it up.

```
vpc 12
no shutdown
```

## (Optional) Configure Network Interfaces for SAP HANA Backup/Data Source/Replication

You can define the port-channel for each type Network to have dedicated bandwidth. Below is an example to create such port-channel for Backup Network, these cables are connected to Storage for Backup. The following example assumes two ports (Ethernet 1/29 and 1/30) are connected to dedicated NFS Storage to backup SAP HANA.

### Cisco Nexus 9000 A and Cisco Nexus 9000 B

1. Define a port description for the interface connecting to <<var\_node01>>.

```
interface Eth1/29
description <<var_backup_node01>>:<<Port_Number>>
```

2. Apply it to a port channel and bring up the interface.



```
interface eth1/29
channel-group 21 mode active
no shutdown
```

3. Define a description for the port-channel connecting to <<var\_backup\_node01>>.

```
interface Po21
description <<var_backup_vlan_id>>
```

4. Make the port-channel a switchport, and configure a trunk to allow NFS VLAN for DATA.

```
switchport
switchport mode trunk
switchport trunk allowed vlan <<var_backup_vlan_id>>
```

5. Make the port channel and associated interfaces spanning tree edge ports.

```
spanning-tree port type edge trunk
```

6. Set the MTU to be 9216 to support jumbo frames.

```
mtu 9216
```

7. Make this a VPC port-channel and bring it up.

```
vpc 21
no shutdown
```

8. Define a port description for the interface connecting to <<var\_node02>>.

```
interface Eth1/30
description <<var_backup_node01>>:<<Port_Number>>
```

9. Apply it to a port channel and bring up the interface.

```
channel-group 22 mode active
no shutdown
```

10. Define a description for the port-channel connecting to <<var\_node02>>.

```
interface Po22
description <<var_backup_node02>>
```

11. Make the port-channel a switchport, and configure a trunk to allow NFS VLAN for DATA.

```
switchport
switchport mode trunk
switchport trunk allowed vlan <<var_backup_vlan_id>>
```

12. Make the port channel and associated interfaces spanning tree edge ports.

```
spanning-tree port type edge trunk
```

13. Set the MTU to be 9216 to support jumbo frames.

```
mtu 9216
```

14. Make this a VPC port-channel and bring it up.

```
vpc 22
```

```
no shutdown
```

## (Optional) Management Plane Access for Cisco UCS Servers

This is an optional step, which can be used to implement a management plane access for the Cisco UCS servers.

### Cisco Nexus 9000 A and Cisco Nexus 9000 B

To enable management access across the IP switching environment, complete the following steps:



You may want to create a dedicated Switch Virtual Interface (SVI) on the Nexus data plane to test and troubleshoot the management plane. If an L3 interface is deployed be sure it is deployed on both Cisco Nexus 9000s to ensure Type-2 VPC consistency.

1. Define a port description for the interface connecting to the management plane.

```
interface Eth1/⟨⟨interface_for_in_band_mgmt⟩⟩
description IB-Mgmt:⟨⟨mgmt_uplink_port⟩⟩
```

2. Apply it to a port channel and bring up the interface.

```
channel-group 6 mode active
no shutdown
```

3. Define a description for the port-channel connecting to management switch.

```
interface Po6
description IB-Mgmt
```

4. Configure the port as an access VLAN carrying the InBand management VLAN traffic.

```
switchport
switchport mode access
switchport access vlan ⟨⟨var_inband_vlan_id⟩⟩
```

5. Make the port channel and associated interfaces normal spanning tree ports.

```
spanning-tree port type normal
```

6. Make this a VPC port-channel and bring it up.

```
vpc 6
no shutdown
```

7. Save the running configuration to start-up in both Nexus 9000s.

```
copy run start
```

## Uplink into Existing Network Infrastructure

Depending on the available network infrastructure, several methods and features can be used to uplink the SAP HANA environment. If an existing Cisco Nexus environment is present, Cisco recommends using vPCs to uplink the Cisco Nexus 9000 switches in the SAP HANA environment to the existing infrastructure. The previously described procedures can be used to create an uplink vPC to the existing environment. Make sure to run `copy run start` to save the configuration on each switch after configuration is completed.

## Cisco UCS Configuration

This section describes the specific configurations on Cisco UCS servers to address SAP HANA requirements.

### Initial Setup of Cisco UCS 6332 Fabric Interconnect

This section provides detailed procedures for configuring the Cisco Unified Computing System (Cisco UCS) for use in SAP HANA Scale Out Solution environment. These steps are necessary to provision the Cisco UCS C-Series and B-Series servers to meet SAP HANA requirement.

#### Cisco UCS 6332 Fabric Interconnect A

To configure the Cisco UCS Fabric Interconnect A, complete the following steps:

1. Connect to the console port on the first Cisco UCS 6300 Fabric Interconnect.

```

Enter the configuration method: console
Enter the setup mode; setup newly or restore from backup.(setup/restore)? setup
You have chosen to setup a a new fabric interconnect? Continue? (y/n): y
Enforce strong passwords? (y/n) [y]: y
Enter the password for "admin": <<var_password>>
Enter the same password for "admin": <<var_password>>
Is this fabric interconnect part of a cluster (select 'no' for standalone)?
(yes/no) [n]: y
Which switch fabric (A|B): A
Enter the system name: <<var_ucs_clustername>>
Physical switch Mgmt0 IPv4 address: <<var_ucsa_mgmt_ip>>
Physical switch Mgmt0 IPv4 netmask: <<var_ucsa_mgmt_mask>>
IPv4 address of the default gateway: <<var_ucsa_mgmt_gateway>>
Cluster IPv4 address: <<var_ucs_cluster_ip>>
Configure DNS Server IPv4 address? (yes/no) [no]: y
DNS IPv4 address: <<var_nameserver_ip>>
Configure the default domain name? y
Default domain name: <<var_dns_domain_name>>
Join centralized management environment (UCS Central)? (yes/no) [n]: Enter

```

2. Review the settings printed to the console. If they are correct, answer yes to apply and save the configuration.
3. Wait for the login prompt to make sure that the configuration has been saved.

#### Cisco UCS 6332 Fabric Interconnect B

To configure the Cisco UCS Fabric Interconnect B, complete the following steps:

1. Connect to the console port on the second Cisco UCS 6332 Fabric Interconnect.

```

Enter the configuration method: console
Installer has detected the presence of a peer Fabric interconnect. This Fabric
interconnect will be added to the cluster. Do you want to continue {y|n}? y
Enter the admin password for the peer fabric interconnect: <<var_password>>
Physical switch Mgmt0 IPv4 address: <<var_ucsb_mgmt_ip>>
Apply and save the configuration (select 'no' if you want to re-enter)? (yes/no):
y

```

2. Wait for the login prompt to make sure that the configuration has been saved.

## Cisco UCS for SAP HANA

### Log in to Cisco UCS Manager

To log in to the Cisco Unified Computing System (UCS) environment, complete the following steps:

1. Open a web browser and navigate to the Cisco UCS 6332 Fabric Interconnect cluster address.
2. Click the Launch Cisco UCS Manager.
3. If prompted to accept security certificates, accept as necessary.
4. When prompted, enter admin as the user name and enter the administrative password.
5. Click Login to log in to the Cisco UCS Manager.

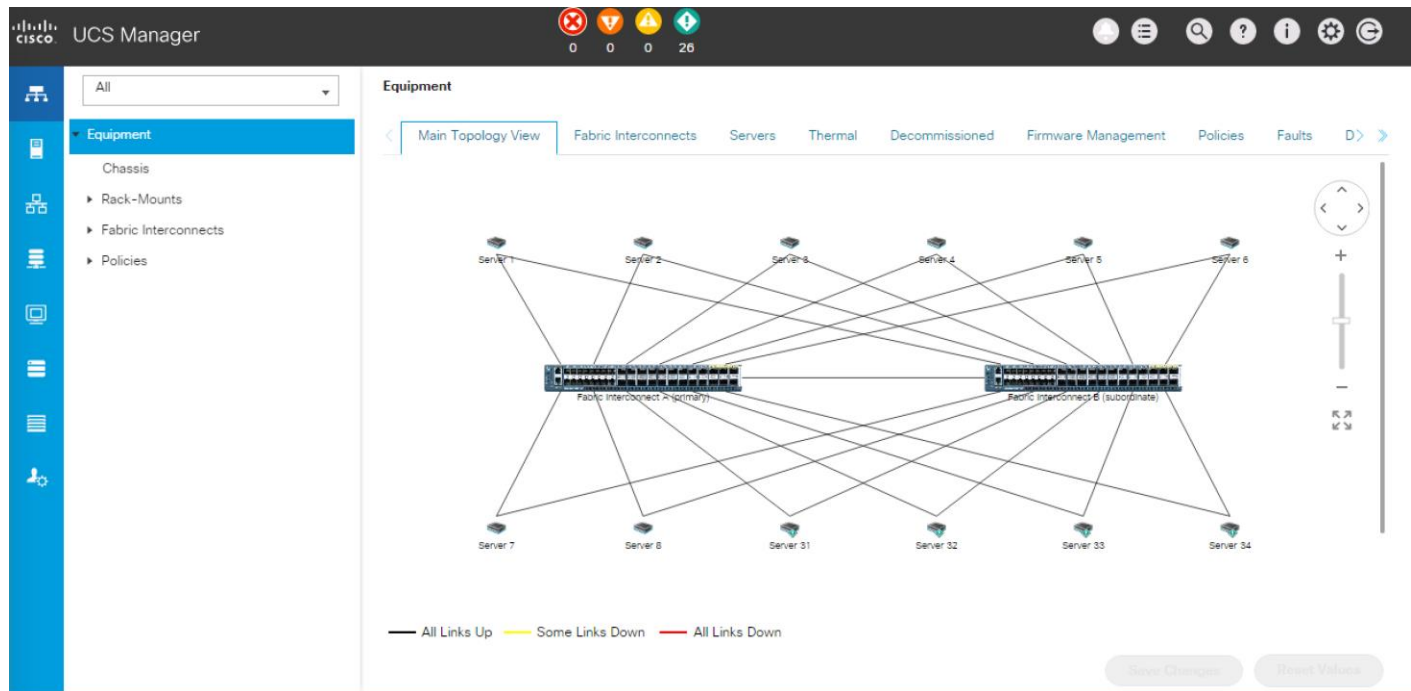

### Upgrade Cisco UCS Manager Software to Version 3.2(2d)

This document assumes you are using Cisco UCS Manager Software version 3.2(2d). To upgrade the Cisco UCS Manager software and the Cisco UCS 6332 Fabric Interconnect software to version 3.2(2d), refer to [Cisco UCS Manager Install and Upgrade Guides](#).

### Add Block of IP Addresses for KVM Access

To create a block of IP addresses for server Keyboard, Video, Mouse (KVM) access in the Cisco UCS environment, complete the following steps:



This block of IP addresses should be in the same subnet as the management IP addresses for the Cisco UCS Manager.

1. In Cisco UCS Manager, click the LAN tab in the navigation pane.

2. Select Pools > root > IP Pools > IP Pool ext-mgmt.
3. In the Actions pane, select Create Block of IPv4 Addresses.
4. Enter the starting IP address of the block and the number of IP addresses required, and the subnet and gateway information.
5. Click OK to create the IP block.
6. Click OK in the confirmation message.

## Synchronize Cisco UCS to NTP

To synchronize the Cisco UCS environment to the NTP server, complete the following steps:

1. In Cisco UCS Manager, click the Admin tab in the navigation pane.
2. Select All > Timezone Management.
3. In the Properties pane, select the appropriate time zone in the Timezone menu.
4. Click Save Changes, and then click OK.
5. Click Add NTP Server.
6. Enter <<var\_global\_ntp\_server\_ip>> and click OK.
7. Click OK.

## Cisco UCS Blade Chassis Connection Options

For the Cisco UCS 6300 Series Fabric Extenders, two configuration options are available: pinning and portchannel. SAP HANA node communicates with every other SAP HANA node using multiple I/O streams and this makes the port-channel option a highly suitable configuration.

### Edit Chassis Discovery Policy

Setting the discovery policy simplifies adding the Cisco UCS B-Series chassis and additional fabric extenders for C-Series connectivity.

To modify the chassis discovery policy, complete the following steps:

1. In Cisco UCS Manager, click the Equipment tab in the navigation pane and select Equipment in the list on the left.
2. In the right pane, click the Policies tab.
3. Under Global Policies, set the Chassis/FEX Discovery Policy to match the number of server ports that are connected between the fabric extenders (FEXes) within the chassis and the fabric interconnects.
4. Set the Link Grouping Preference to Port Channel.
5. Click Save Changes.
6. Click OK.

## Equipment

[Main Topology View](#)
[Fabric Interconnects](#)
[Servers](#)
[Thermal](#)
[Global Policies](#)
[Autoconfig Policies](#)
[Server Inheritance Policies](#)

### Chassis/FEX Discovery Policy

Action :

Link Grouping Preference :  None  Port Channel

Backplane Speed Preference :  40G  4x10G

### Enable Server and Uplink Ports

To enable server and uplink ports, complete the following steps:

1. In Cisco UCS Manager, click the Equipment tab in the navigation pane.
2. Select Equipment > Fabric Interconnects > Fabric Interconnect A (primary) > Fixed Module.
3. Expand Ethernet Ports.
4. Select the ports that are connected to the chassis and / or to the Cisco C-Series Server (two per FI), right-click them, and select Configure as Server Port.
5. Click Yes to confirm server ports and click OK.
6. Verify that the ports connected to the chassis and / or to the Cisco C-Series Server are now configured as server ports.

Equipment / Fabric Interconnects / Fabric Interconnect A (... / Fixed Module / Ethernet Ports

Ethernet Ports

Advanced Filter Export Print All Unconfigured Network  Server FCoE Uplink Unified Uplink Appliance Storage FCoE Storage » ⚙

Slot	Aggr. Port ID	Port ID	MAC	If Role	If Type	Overall Status	Admin State
1	0	17	8C:60:4F:BC:C5:34	Server	Physical	↑ Up	↑ Enabled
1	0	18	8C:60:4F:BC:C5:38	Server	Physical	↑ Up	↑ Enabled
1	0	19	8C:60:4F:BC:C5:3C	Server	Physical	↑ Up	↑ Enabled
1	0	20	8C:60:4F:BC:C5:40	Server	Physical	↑ Up	↑ Enabled
1	0	21	8C:60:4F:BC:C5:44	Server	Physical	↑ Up	↑ Enabled
1	0	22	8C:60:4F:BC:C5:48	Server	Physical	↑ Up	↑ Enabled
1	0	23	8C:60:4F:BC:C5:4C	Server	Physical	↑ Up	↑ Enabled
1	0	24	8C:60:4F:BC:C5:50	Server	Physical	↑ Up	↑ Enabled
1	0	26	8C:60:4F:BC:C5:58	Server	Physical	↑ Up	↑ Enabled
1	0	27	8C:60:4F:BC:C5:5C	Server	Physical	↑ Up	↑ Enabled
1	0	28	8C:60:4F:BC:C5:60	Server	Physical	↑ Up	↑ Enabled
1	0	29	8C:60:4F:BC:C5:64	Server	Physical	↑ Up	↑ Enabled
1	0	32	8C:60:4F:BC:C5:70	Server	Physical	↑ Up	↑ Enabled
1	0	33	8C:60:4F:BC:C5:74	Server	Physical	↑ Up	↑ Enabled

7. Select ports that are connected to the Cisco Nexus switches, right-click them, and select Configure as Uplink Port.
8. Click Yes to confirm uplink ports and click OK.
9. Select Equipment > Fabric Interconnects > Fabric Interconnect B (subordinate) > Fixed Module.
10. Expand Ethernet Ports.
11. Select the ports that are connected to the chassis or to the Cisco C-Series Server (two per FI), right-click them, and select Configure as Server Port.
12. Click Yes to confirm server ports and click OK.
13. Select ports that are connected to the Cisco Nexus switches, right-click them, and select Configure as Uplink Port.
14. Click Yes to confirm the uplink ports and click OK.

## Configure Breakout Ports

The 40 GB Ethernet ports on Cisco UCS 6300 Fabric Interconnects can be configured as four breakout 10 GB ports using a supported breakout cable.



Configuring breakout ports requires rebooting the Fabric Interconnect. Any existing configuration on a port is erased. It is recommended to break out all required ports in a single transaction.

1. In Cisco UCS Manager, click the Equipment tab in the navigation pane.
2. Select Equipment > Fabric Interconnects > Fabric Interconnect A (primary) > Fixed Module.
3. Expand Ethernet Ports.

4. Select ports that are connected to the Cisco Nexus 3524 switches, right-click them, and select Configure Breakout Port.
5. Click Yes to confirm the Breakout ports and click OK.
6. Select Equipment > Fabric Interconnects > Fabric Interconnect B (subordinate) > Fixed Module.
7. Expand Ethernet Ports.
8. Select ports that are connected to the Cisco Nexus 3524 switches, right-click them, and select Configure Breakout Port.
9. Click Yes to confirm the Breakout ports and click OK.



When you configure a breakout port, you can configure each 10 GB sub-port as server, uplink, FCoE uplink, FCoE storage or appliance as required. Unified Ports cannot be configured as Breakout Ports.

---

## Acknowledge Cisco UCS Chassis and Rack-Mount Servers

To acknowledge all Cisco UCS chassis and Rack Mount Servers, complete the following steps:

1. In Cisco UCS Manager, click the Equipment tab in the navigation pane.
2. Expand Chassis and select each chassis that is listed.
3. Right-click each chassis and select Acknowledge Chassis.
4. Click Yes and then click OK to complete acknowledging the chassis.
5. If C-Series servers are part of the configuration, expand Rack Mounts and FEX.
6. Right-click each Server that is listed and select Acknowledge Server.
7. Click Yes and then click OK to complete acknowledging the Rack Mount Servers.

## Create Uplink Port Channels

A separate uplink port-channel for each of the network zones are defined as per SAP. For example, create port-channel 11 on fabric interconnect A and port-channel 12 on fabric interconnect B for Client zone network.

To configure the necessary port channels out of the Cisco UCS environment, complete the following steps:

1. In Cisco UCS Manager, click the LAN tab in the navigation pane.
2. In this procedure, two port channels are created: one from fabric A to both Cisco Nexus switches and one from fabric B to both Cisco Nexus switches.
3. Under LAN > LAN Cloud, expand the Fabric A tree.
4. Right-click Port Channels.
5. Select Create Port Channel.
6. Enter 11 as the unique ID of the port channel.
7. Enter vPC-11-Nexus as the name of the port channel.



8. Click Next.

The screenshot shows the 'Create Port Channel' configuration interface. A blue sidebar on the left indicates the current step is '1 Set Port Channel Name', with the next step being '2 Add Ports'. The main configuration area on the right has the following fields:

- ID :
- Name :

9. Select the following ports to be added to the port channel:

- Slot ID 1 and port 1
- Slot ID 1 and port 2

10. If the breakout cables are used for Uplink connectivity. Select the following ports to be added to the port channel:

- Slot ID 1, Aggregated Port ID 1 and port 1
- Slot ID 1, Aggregated Port ID 1 and port 2
- Slot ID 1, Aggregated Port ID 1 and port 3
- Slot ID 1, Aggregated Port ID 1 and port 4
- Slot ID 1, Aggregated Port ID 2 and port 1
- Slot ID 1, Aggregated Port ID 2 and port 2
- Slot ID 1, Aggregated Port ID 2 and port 3
- Slot ID 1, Aggregated Port ID 2 and port 4

11. Click >> to add the ports to the port channel.

12. Click Finish to create the port channel.

13. Click OK.

14. In the navigation pane, under LAN > LAN Cloud, expand the fabric B tree.

15. Right-click Port Channels.

16. Select Create Port Channel.

17. Enter 12 as the unique ID of the port channel.

18. Enter vPC-12-NEXUS as the name of the port channel.

19. Click Next.

20. Select the following ports to be added to the port channel:

- Slot ID 1 and port 1
- Slot ID 1 and port 2

21. If the breakout cables are used for Uplink connectivity. Select the following ports to be added to the port channel:

- Slot ID 1, Aggregated Port ID 1 and port 1
- Slot ID 1, Aggregated Port ID 1 and port 2
- Slot ID 1, Aggregated Port ID 1 and port 3
- Slot ID 1, Aggregated Port ID 1 and port 4
- Slot ID 1, Aggregated Port ID 2 and port 1
- Slot ID 1, Aggregated Port ID 2 and port 2
- Slot ID 1, Aggregated Port ID 2 and port 3
- Slot ID 1, Aggregated Port ID 2 and port 4

22. Click >> to add the ports to the port channel.

23. Click Finish to create the port channel.

24. Click OK.

Repeat the steps 1-24 to create Additional port-channel for each network zone based on your Data Center requirements.

If you are using single Nexus 3524 for IOM failover, create port-channel 5 on fabric interconnect A and portchannel 6 on fabric interconnect B for Internal network zone.

To configure the necessary port channels out of the Cisco UCS environment, complete the following steps:

1. In Cisco UCS Manager, click the LAN tab in the navigation pane.
2. In this procedure, two port channels are created: one from fabric A to both Cisco Nexus switches and one from fabric B to both Cisco Nexus switches.
3. Under LAN > LAN Cloud, expand the Fabric A tree.
4. Right-click Port Channels.
5. Select Create Port Channel.
6. Enter 5 as the unique ID of the port channel.
7. Enter N3k-Uplink as the name of the port channel.
8. Click Next.
9. Select the following ports to be added to the port channel:

- Slot ID 1, Aggregated Port ID 3 and port 1
  - Slot ID 1, Aggregated Port ID 3 and port 2
  - Slot ID 1, Aggregated Port ID 3 and port 3
  - Slot ID 1, Aggregated Port ID 3 and port 4
10. Click >> to add the ports to the port channel.
  11. Click Finish to create the port channel.
  12. Click OK.
  13. In the navigation pane, under LAN > LAN Cloud, expand the fabric B tree.
  14. Right-click Port Channels.
  15. Select Create Port Channel.
  16. Enter 6 as the unique ID of the port channel.
  17. Enter N3k-Uplink as the name of the port channel.
  18. Click Next.
  19. Select the following ports to be added to the port channel:
    - Slot ID 1, Aggregated Port ID 3 and port 1
    - Slot ID 1, Aggregated Port ID 3 and port 2
    - Slot ID 1, Aggregated Port ID 3 and port 3
    - Slot ID 1, Aggregated Port ID 3 and port 4
  20. Click >> to add the ports to the port channel.
  21. Click Finish to create the port channel.
  22. Click OK.

## Create New Organization

For secure multi-tenancy within the Cisco UCS domain, a logical entity created known as organizations.

To create organization unit, complete the following steps:

1. In Cisco UCS Manager, on the Tool bar click New.
2. From the drop-down list select Create Organization.
3. Enter the Name as HANA.
4. (Optional) Enter the Description as Org for HANA.
5. Click OK to create the Organization.

## Create MAC Address Pools

To configure the necessary MAC address pools for the Cisco UCS environment, complete the following steps:

1. In Cisco UCS Manager, click the LAN tab in the navigation pane.
2. Select Pools > root > Sub-Organization > HANA.
3. In this procedure, two MAC address pools are created, one for each switching fabric.
4. Right-click MAC Pools under the root organization.
5. Select Create MAC Pool to create the MAC address pool.
6. Enter FI-A as the name of the MAC pool.
7. (Optional) Enter a description for the MAC pool.
8. Choose Assignment Order Sequential.
9. Click Next.
10. Click Add.
11. Specify a starting MAC address.
12. The recommendation is to place 0A in the next-to-last octet of the starting MAC address to identify all of the MAC addresses as Fabric Interconnect A addresses.
13. Specify a size for the MAC address pool that is sufficient to support the available blade or server resources.

### Create a Block of MAC Addresses

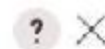

First MAC Address :  Size :

To ensure uniqueness of MACs in the LAN fabric, you are strongly encouraged to use the following MAC prefix:  
**00:25:B5:xx:xx:xx**



14. Click OK.
15. Click Finish.
16. In the confirmation message, click OK.
17. Right-click MAC Pools under the HANA organization.
18. Select Create MAC Pool to create the MAC address pool.

19. Enter FI-B as the name of the MAC pool.
20. (Optional) Enter a description for the MAC pool.
21. Click Next.
22. Click Add.
23. Specify a starting MAC address.



The recommendation is to place 0B in the next to last octet of the starting MAC address to identify all the MAC addresses in this pool as fabric B addresses.

---

24. Specify a size for the MAC address pool that is sufficient to support the available blade or server resources.
25. Click OK.
26. Click Finish.
27. In the confirmation message, click OK.



You can also define separate MAC address Pool for each Network Zone. Follow the above steps 1-16 to create MAC address pool for each Network Zone.

---

## Create UUID Suffix Pool

To configure the necessary universally unique identifier (UUID) suffix pool for the Cisco UCS environment, complete the following steps:

1. In Cisco UCS Manager, click the Servers tab in the navigation pane.
2. Select Pools > root.
3. Right-click UUID Suffix Pools.
4. Select Create UUID Suffix Pool.
5. Enter UUID\_Pool as the name of the UUID suffix pool.
6. (Optional) Enter a description for the UUID suffix pool.
7. Keep the Prefix as the Derived option.
8. Select Sequential for Assignment Order.
9. Click Next.
10. Click Add to add a block of UUIDs.
11. Keep the From field at the default setting.
12. Specify a size for the UUID block that is sufficient to support the available blade or server resources.
13. Click OK.

14. Click Finish.
15. Click OK.

## Power Policy

To run Cisco UCS with two independent power distribution units, the redundancy must be configured as Grid. Complete the following steps:

1. In Cisco UCS Manager, click the Equipment tab in the navigation pane and select Equipment in the list on the left.
2. In the right pane, click the Policies tab.
3. Under Global Policies, set the Redundancy field in Power Policy to Grid.
4. Click Save Changes.
5. Click OK.

## Power Control Policy

Power Capping feature in Cisco UCS is designed to save power with a legacy data center use cases. This feature does not contribute much to the high performance behavior of SAP HANA. By choosing the option “No Cap” for power control policy, the SAP HANA server nodes will not have a restricted power supply. It is recommended to have this power control policy to make sure sufficient power supply for high performance and critical applications like SAP HANA.

To create a power control policy for the Cisco UCS environment, complete the following steps:

1. In Cisco UCS Manager, click the Servers tab in the navigation pane.
2. Select Policies > root.
3. Right-click Power Control Policies.
4. Select Create Power Control Policy.
5. Enter HANA as the Power Control Policy name.
6. Change the Power Capping setting to No Cap.
7. Click OK to create the power control policy.
8. Click OK.

## Create Power Control Policy



Name :

Description :

Fan Speed Policy :

### Power Capping

If you choose **cap**, the server is allocated a certain amount of power based on its priority within its power group. Priority values range from 1 to 10, with 1 being the highest priority. If you choose **no-cap**, the server is exempt from all power capping.

No Cap  cap

Cisco UCS Manager only enforces power capping when the servers in a power group require more power than is currently available. With sufficient power, all servers run at full capacity regardless of their priority.

## Create Host Firmware Package

Firmware management policies allow the administrator to select the corresponding packages for a given server configuration. These policies often include packages for adapter, BIOS, board controller, FC adapters, host bus adapter (HBA) option ROM, and storage controller properties.

To create a firmware management policy for a given server configuration in the Cisco UCS environment, complete the following steps:

1. In Cisco UCS Manager, click the Servers tab in the navigation pane.
2. Select Policies > root.
3. Right-click Host Firmware Packages.
4. Select Create Host Firmware Package.
5. Enter HANA-FW as the name of the host firmware package.
6. Leave Simple selected.
7. Select the version 3.2(2d) for both the Blade and Rack Packages.
8. Click OK to create the host firmware package.
9. Click OK.

## Create Host Firmware Package

Name :

Description :

How would you like to configure the Host Firmware Package?

Simple  Advanced

Blade Package :

Rack Package :

Service Pack :

The images from Service Pack will take precedence over the images from Blade or Rack Package

Excluded Components:

- Adapter
- BIOS
- Board Controller
- CMC
- FC Adapters
- Flex Flash Controller
- GPUe
- HBA Option ROM
- Host NIC
- Host NIC Option ROM

OK

Cancel

## Create Local Disk Configuration Policy

A local disk configuration policy configures SAS local drives that have been installed on a server through the onboard RAID controller of the local drive.

To create a local disk configuration policy for HANA servers for Local OS disks, complete the following steps:

1. In Cisco UCS Manager, click the Servers tab in the navigation pane.
2. Select Policies > root.
3. Right-click Local Disk Config Policies.
4. Select Create Local Disk Configuration Policy.
5. Enter RAID1 as the local disk configuration policy name.
6. Change the mode to RAID 1.
7. Click OK to create the local disk configuration policy.



## Create Local Disk Configuration Policy



Name :

Description :

Mode :

Protect Configuration :

If **Protect Configuration** is set, the local disk configuration is preserved if the service profile is disassociated with the server. In that case, a configuration error will be raised when a new service profile is associated with that server if the local disk configuration in that profile is different.

### FlexFlash

FlexFlash State :  Disable  Enable

If **FlexFlash State** is disabled, SD cards will become unavailable immediately. Please ensure SD cards are not in use before disabling the FlexFlash State.

FlexFlash RAID Reporting State :  Disable  Enable



8. Click OK.

To create a local disk configuration policy for MapR servers, complete the following steps:

1. In Cisco UCS Manager, click the Servers tab in the navigation pane.
2. Select Policies > root.

3. Right-click Local Disk Config Policies.
4. Select Create Local Disk Configuration Policy.
5. Enter MapR as the local disk configuration policy name.
6. Change the mode to Any Configuration.
7. Click OK to create the local disk configuration policy.

### Create Server BIOS Policy

To get best performance for HANA it is required to configure the Server BIOS accurately. To create a server BIOS policy for the Cisco UCS environment, complete the following steps:

1. In Cisco UCS Manager, click the Servers tab in the navigation pane.
2. Select Policies > root > Sub-Organization > HANA.
3. Right-click BIOS Policies.
4. Select Create BIOS Policy.
5. Enter HANA-BIOS as the BIOS policy name.
6. Click OK.

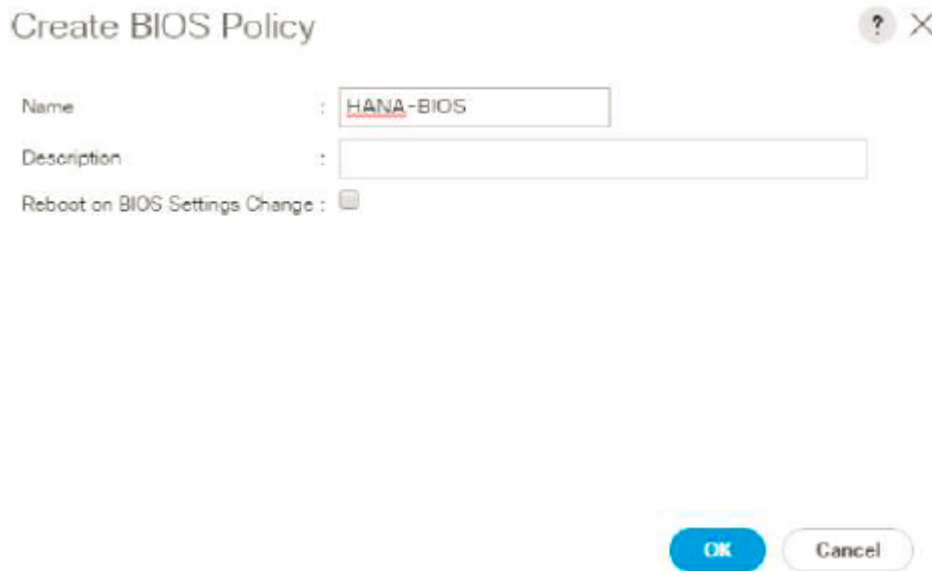

7. Under BIOS Policies, Click the newly created HANA-BIOS Policy.
8. In the Main pane, under BIOS Setting choose Disabled for Quiet Boot.
9. Click the Advance tab.
10. The recommendation from SAP for SAP HANA is to disable all Processor C States. This will force the CPU to stay on maximum frequency and allow SAP HANA to run with best performance.
11. Under Processor choose Disabled for all C-States.

12. Set HPC for CPU Performance, Performance for Power Technology, Energy Performance.

Servers / Policies / root / BIOS Policies / HANA-BIOS

Main **Advanced** Boot Options Server Management Events

**Processor** Intel Directed IO RAS Memory Serial Port USB PCI QPI LOM and PCIe Slots Trusted Platform Graphics Configuration

Advanced Filter Export Print

BIOS Setting	Value
P STATE Coordination	Platform Default
Package C State Limit	Platform Default
Processor C State	Disabled
Processor C1E	Disabled
Processor C3 Report	Disabled
Processor C6 Report	Disabled
Processor C7 Report	Disabled
Processor CMC1	Platform Default
Power Technology	Performance
Energy Performance	Performance
Adjacent Cache Line Prefetcher	Platform Default
DCU IP Prefetcher	Platform Default
DCU Streamer Prefetch	Platform Default

Add Delete Info

**Save Changes** Reset Values

13. Click RAS Memory.

14. Select Maximum-Performance for Memory RAS Configuration and Enabled for NUMA optimized.

Servers / Policies / root / BIOS Policies / HANA-BIOS

Main **Advanced** Boot Options Server Management Events

Processor Intel Directed IO **RAS Memory** Serial Port USB PCI QPI LOM and PCIe Slots Trusted Platform Graphics Configuration

Advanced Filter Export Print

BIOS Setting	Value
DDR3 Voltage Selection	Platform Default
DRAM Refresh Rate	Platform Default
LV DDR Mode	Performance Mode
Mirroring Mode	Platform Default
NUMA optimized	Enabled
Memory RAS configuration	Maximum Performance

15. Click Serial Port.

16. Select Enabled for Serial Port A enable.

Servers / Policies / root / BIOS Policies / HANA-BIOS

Main Advanced **Boot Options** Server Management Events

Processor Intel Directed IO RAS Memory **Serial Port** USB PCI QPI LOM and PCIe Slots Trusted Platform Graphics Configuration

Advanced Filter Export Print

BIOS Setting	Value
Serial port A enable	Enabled

17. Click Server Management.

18. Choose 115.2k for BAUD Rate, Enabled for Legacy OS redirection, VT100-PLUS for Terminal type. This is used for Serial Console Access over LAN to all SAP HANA servers.

Servers / Policies / root / BIOS Policies / HANA-BIOS

Main Advanced Boot Options **Server Management** Events

Advanced Filter Export Print

BIOS Setting	Value
Assert NMI on PERR	Platform Default
Assert NMI on SERR	Platform Default
Baud rate	115.2k
Console redirection	Serial Port A
Flow Control	Platform Default
Legacy OS redirection	Enabled
Putty KeyPad	Platform Default
Terminal type	VT100-PLUS
FRB-2 Timer	Platform Default
OS Boot Watchdog Timer Policy	Platform Default
OS Boot Watchdog Timer Timeout	Platform Default
OS Boot Watchdog Timer	Platform Default
Out of Band Management	Platform Default
Redirection After BIOS POST	Platform Default

19. Click Save Changes.

To create a server BIOS policy for MapR server, complete the following steps:

1. In Cisco UCS Manager, click the Servers tab in the navigation pane.
2. Select Policies > root > Sub-Organization > HANA.
3. Right-click BIOS Policies.
4. Select Create BIOS Policy.
5. Enter MapR-BIOS as the BIOS policy name.
6. Click OK.
7. Under BIOS Policies, click the newly created MapR-BIOS Policy.

8. In the Main pane, under BIOS Setting choose Disabled for Quiet Boot.
9. Click Advance tab.
10. Under Processor choose Disabled for all C-States. This will force the CPU to stay on maximum frequency and allow MapR Server to run with best performance.
11. Choose Enabled for Enhanced Intel SpeedStep Tech, Intel Hyper Threading Tech, Intel Turbo Boost Tech.
12. Set High Throughput for CPU Performance.
13. Choose Performance for Power Technology, Energy Performance, DRAM Clock Throttling.

Servers / Policies / root / BIOS Policies / MapR-BIOS

Main **Advanced** Boot Options Server Management Events

Processor Intel Directed IO RAS Memory Serial Port USB PCI QPI LOM and PCIe Slots Trusted Platform Graphics Configuration

Advanced Filter Export Print

BIOS Setting	Value
Altitude	Platform Default
GPU Hardware Power Management	Platform Default
Boot Performance Mode	Platform Default
CPU Performance	High Throughput
Core Multi Processing	All
DRAM Clock Throttling	Performance
Direct Cache Access	Platform Default
Energy Performance Tuning	Platform Default
Enhanced Intel SpeedStep Tech	Enabled
Execute Disable Bit	Platform Default
Frequency Floor Override	Platform Default
Intel HyperThreading Tech	Enabled
Intel Turbo Boost Tech	Enabled
Intel Virtualization Technology	Disabled

Add Delete Info

14. Click RAS Memory.
15. Select Maximum-Performance for Memory RAS Configuration and Enabled for NUMA optimized.
16. Click Save Changes.

## Create Serial Over LAN Policy

The Serial over LAN policy is required to get console access to all the SAP HANA servers through SSH from the management network. This is used in case of the server hang or a Linux kernel crash, where the dump is required. Configure the speed in the Server Management Tab of the BIOS Policy. To create the serial over LAN policy, complete the following steps:

1. In Cisco UCS Manager, click the Servers tab in the navigation pane.
2. Select Policies > root > Sub-Organization > HANA.

3. Right-click the Serial over LAN Policies.
4. Select Create Serial over LAN Policy.
5. Enter SoL-Console as the Policy name.
6. Select Serial over LAN State to enable.
7. Change the Speed to 115200.
8. Click OK.

## Create Serial over LAN Policy

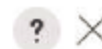

Name :

Description :

Serial over LAN State :  Disable  Enable

Speed :



### Update Default Maintenance Policy

It is recommended to update the default Maintenance Policy with the Reboot Policy “User Ack” for the SAP HANA server. This policy will wait for the administrator to acknowledge the server reboot for the configuration changes to take effect.

To update the default Maintenance Policy, complete the following steps:

1. In Cisco UCS Manager, click the Servers tab in the navigation pane.
2. Select Policies > root.
3. Select Maintenance Policies > default.
4. Change the Reboot Policy to User Ack.
5. Click Save Changes.
6. Click OK to accept the change.

Servers / Policies / root / Maintenance Policies / default

General	Events
<b>Actions</b> <hr/> Delete Show Policy Usage Use Global	<b>Properties</b> <hr/> Name : <b>default</b> Description : <input type="text"/> Owner : <b>Local</b> Soft Shutdown Timer : 150 Secs Storage Config. Deployment Policy : <input type="radio"/> Immediate <input checked="" type="radio"/> User Ack Reboot Policy : <input type="radio"/> Immediate <input checked="" type="radio"/> User Ack <input type="radio"/> Timer Automatic <input checked="" type="checkbox"/> On Next Boot (Apply pending changes at next reboot.)

## IPMI Access Profiles

The Serial over LAN access requires an IPMI access control to the board controller. This is also used for the STONITH function of the SAP HANA mount API to kill a hanging server. The default user is “sapadm” with the password “cisco”.

To create an IPMI Access Profile, complete the following steps:

1. In Cisco UCS Manager, click the Servers tab in the navigation pane.
2. Select Policies > root > Sub-Organization > HANA.
3. Right-click IPMI Access Profiles.
4. Select Create IPMI Access Profile.
5. Enter HANA-IPMI as the Profile name.
6. Click + button.
7. Enter Username in the Name field and password.
8. Select Admin as Role.

### Create IPMI User



Name :

Password :

Confirm Password :

Role :  Read Only  Admin

Description :

- 9. Click OK to create user.
- 10. Click OK to Create IPMI Access Profile.

### Create IPMI Access Profile



Name :

Description :

IPMI Over LAN :  Disable  Enable

IPMI Users

+ - ▾ Advanced Filter ↑ Export 🖨 Print ⚙	
Name	Role
sapadm	Admin



## Network Configuration

The core network requirements for SAP HANA are covered by Cisco UCS defaults. Cisco UCS is based on 40GbE and provides redundancy through the Dual Fabric concept. The Service Profile is configured to distribute the traffic across Fabric Interconnect A and B. During normal operation, the traffic in the inter-node flows on FI A and the Storage traffic is on FI B. The inter-node traffic flows from a Blade Server to the Fabric Interconnect A and back to other Blade Server. The storage traffic flows from a HANA Server to the Fabric Interconnect B and back to MapR Server.

### Set Jumbo Frames in Cisco UCS Fabric

To configure jumbo frames and enable quality of service in the Cisco UCS fabric, complete the following steps:

1. In Cisco UCS Manager, click the LAN tab in the navigation pane.
2. Select LAN > LAN Cloud > QoS System Class.
3. In the right pane, click the General tab.
4. On the MTU Column, enter 9216 in the box.
5. Check Enabled Under Priority for Silver.
6. Click Save Changes in the bottom of the window.
7. Click OK.

LAN

LAN Uplinks VLANs Server Links MAC Identity Assignment IP Identity Assignment **QoS** Global Policies Faults Events FSM

Priority	Enabled	CoS	Packet Drop	Weight	Weight (%)	MTU	Multicast Optimized
Platinum	<input type="checkbox"/>	5	<input type="checkbox"/>	10	N/A	9128	<input type="checkbox"/>
Gold	<input type="checkbox"/>	4	<input checked="" type="checkbox"/>	9	N/A	9128	<input type="checkbox"/>
Silver	<input checked="" type="checkbox"/>	2	<input checked="" type="checkbox"/>	5	N/A	9128	<input type="checkbox"/>
Bronze	<input type="checkbox"/>	1	<input checked="" type="checkbox"/>	7	N/A	9128	<input type="checkbox"/>
Best Effort	<input checked="" type="checkbox"/>	Any	<input checked="" type="checkbox"/>	5	100	9128	<input type="checkbox"/>
Fibre Channel	<input checked="" type="checkbox"/>	3	<input type="checkbox"/>	none	N/A	fc	N/A

## Network Control Policy

### Update Default Network Control Policy to Enable CDP

CDP needs to be enabled to learn the MAC address of the End Point. To update default Network Control Policy, complete the following steps:

1. In Cisco UCS Manager, click the LAN tab in the navigation pane.
2. Select LAN > Policies > root > Network Control Policies > default.
3. In the right pane, click the General tab.

4. For CDP: select Enabled radio button.
5. Click Save Changes in the bottom of the window.
6. Click OK.

LAN / Policies / root / Network Control Policies / default

General	Events
<p><b>Actions</b></p> <hr/> <p>Delete</p> <p>Show Policy Usage</p> <p>Use Global</p>	<p><b>Properties</b></p> <hr/> <p>Name : <b>default</b></p> <p>Description : <input type="text"/></p> <p>Owner : <b>Local</b></p> <p>CDP : <input type="radio"/> Disabled <input checked="" type="radio"/> Enabled</p> <p>MAC Register Mode : <input checked="" type="radio"/> Only Native Vlan <input type="radio"/> All Host Vlans</p> <p>Action on Uplink Fail : <input checked="" type="radio"/> Link Down <input type="radio"/> Warning</p> <p><b>MAC Security</b></p> <hr/> <p>Forge : <input checked="" type="radio"/> Allow <input type="radio"/> Deny</p> <p><b>LLDP</b></p> <hr/> <p>Transmit : <input checked="" type="radio"/> Disabled <input type="radio"/> Enabled</p> <p>Receive : <input checked="" type="radio"/> Disabled <input type="radio"/> Enabled</p>

### Create Network Control Policy for Internal Network

In order to keep the vNIC links up in case of Nexus 3524 failure, create the Network Control Policy for Internal Network. To create Network Control Policy for Internal Network, complete the following steps:

1. In Cisco UCS Manager, click the LAN tab in the navigation pane.
2. Select LAN > Policies > root > Network Control Policies > right-click and Select Create Network Control Policy.
3. Enter Internal as the Name of the Policy.
4. For CDP: select Enabled radio button.
5. For Action on Uplink Fail, select Warning radio button.
6. Click OK.

## Create Network Control Policy



Name :

Description :

CDP :  Disabled  Enabled

MAC Register Mode :  Only Native Vlan  All Host Vlans

Action on Uplink Fail :  Link Down  Warning

### Warning

IMPORTANT: If the Action on Uplink Fail is set to **Warning**, the fabric **will not** fail over if uplink connectivity is lost

### MAC Security

MAC Security:  All  None

OK

Cancel

## LAN Configurations

Within Cisco UCS, all the network types for an SAP HANA system are reflected by defined VLANs. Network design from SAP has seven SAP HANA related networks and two infrastructure related networks. The VLAN IDs can be changed if required to match the VLAN IDs in the data center network; for example, ID 221 for backup should match the configured VLAN ID at the data center network switches. Even though nine VLANs are defined, VLANs for all the networks are not necessary if the solution will not use the network. For example, if the Replication Network is not used in the solution, then VLAN ID 225 need not be created.

### Create VLANs

To configure the necessary VLANs for the Cisco UCS environment, complete the following steps:

1. In Cisco UCS Manager, click the LAN tab in the navigation pane.



In this procedure, nine VLANs are created.

2. Select LAN > LAN Cloud.
3. Right-click VLANs.
4. Select Create VLANs.
5. Enter HANA-Internal as the name of the VLAN to be used for HANA Node to Node network.
6. Keep the Common/Global option selected for the scope of the VLAN.
7. Enter <<var\_internal\_vlan\_id>> as the ID of the HANA Node to Node network.
8. Keep the Sharing Type as None.
9. Click OK.

## Create VLANs

VLAN Name/Prefix :

Multicast Policy Name :  [Create Multicast Policy](#)

Common/Global
  Fabric A
  Fabric B
  Both Fabrics Configured Differently

You are creating global VLANs that map to the same VLAN IDs in all available fabrics. Enter the range of VLAN IDs.(e.g. " 2009-2019" , " 29,35,40-45" , " 23" , " 23,34-45" )

VLAN IDs :

Sharing Type :  None  Primary  Isolated  Community

10. Repeat the Steps 1-9 for each VLAN.

11. Create VLAN for HANA-AppServer.

## Create VLANs

VLAN Name/Prefix :

Multicast Policy Name :  [Create Multicast Policy](#)

Common/Global
  Fabric A
  Fabric B
  Both Fabrics Configured Differently

You are creating global VLANs that map to the same VLAN IDs in all available fabrics. Enter the range of VLAN IDs.(e.g. " 2009-2019" , " 29,35,40-45" , " 23" , " 23,34-45" )

VLAN IDs :

Sharing Type :  None  Primary  Isolated  Community

12. Create VLAN for HANA-Backup.

## Create VLANs

VLAN Name/Prefix :

Multicast Policy Name :  [Create Multicast Policy](#)

Common/Global  Fabric A  Fabric B  Both Fabrics Configured Differently

You are creating global VLANs that map to the same VLAN IDs in all available fabrics.  
Enter the range of VLAN IDs.(e.g. " 2009-2019" , " 29,35,40-45" , " 23" , " 23,34-45" )

VLAN IDs :

Sharing Type :  None  Primary  Isolated  Community

13. Create VLAN for HANA-Client.

## Create VLANs

VLAN Name/Prefix :

Multicast Policy Name :  [Create Multicast Policy](#)

Common/Global  Fabric A  Fabric B  Both Fabrics Configured Differently

You are creating global VLANs that map to the same VLAN IDs in all available fabrics.  
Enter the range of VLAN IDs.(e.g. " 2009-2019" , " 29,35,40-45" , " 23" , " 23,34-45" )

VLAN IDs :

Sharing Type :  None  Primary  Isolated  Community

14. Create VLAN for HANA-DataSource.

## Create VLANs

VLAN Name/Prefix :

Multicast Policy Name :  [Create Multicast Policy](#)

Common/Global
  Fabric A
  Fabric B
  Both Fabrics Configured Differently

You are creating global VLANs that map to the same VLAN IDs in all available fabrics. Enter the range of VLAN IDs.(e.g. " 2009-2019", " 29,35,40-45", " 23", " 23,34-45")

VLAN IDs :

Sharing Type :  None  Primary  Isolated  Community

15. Create VLAN for HANA-Replication.

## Create VLANs

VLAN Name/Prefix :

Multicast Policy Name :  [Create Multicast Policy](#)

Common/Global
  Fabric A
  Fabric B
  Both Fabrics Configured Differently

You are creating global VLANs that map to the same VLAN IDs in all available fabrics. Enter the range of VLAN IDs.(e.g. " 2009-2019", " 29,35,40-45", " 23", " 23,34-45")

VLAN IDs :

Sharing Type :  None  Primary  Isolated  Community

16. Create VLAN for HANA-Storage.



## Create VLANs

VLAN Name/Prefix :

Multicast Policy Name :  [Create Multicast Policy](#)

Common/Global  Fabric A  Fabric B  Both Fabrics Configured Differently

You are creating global VLANs that map to the same VLAN IDs in all available fabrics. Enter the range of VLAN IDs.(e.g. "2009-2019", "29,35,40-45", "23", "23,34-45")

VLAN IDs :

Sharing Type :  None  Primary  Isolated  Community

17. Create VLAN for NFS-IPMI for Inband Access.

## Create VLANs

VLAN Name/Prefix :

Multicast Policy Name :  [Create Multicast Policy](#)

Common/Global  Fabric A  Fabric B  Both Fabrics Configured Differently

You are creating global VLANs that map to the same VLAN IDs in all available fabrics. Enter the range of VLAN IDs.(e.g. "2009-2019", "29,35,40-45", "23", "23,34-45")

VLAN IDs :

Sharing Type :  None  Primary  Isolated  Community

18. Create VLAN for Management.

## Create VLANs

VLAN Name/Prefix :

Multicast Policy Name :  [Create Multicast Policy](#)

Common/Global  Fabric A  Fabric B  Both Fabrics Configured Differently

You are creating global VLANs that map to the same VLAN IDs in all available fabrics. Enter the range of VLAN IDs.(e.g. "2009-2019", "29,35,40-45", "23", "23,34-45")

VLAN IDs :

Sharing Type :  None  Primary  Isolated  Community

## 19. Create VLAN for MapR-01.

## Create VLANs

VLAN Name/Prefix :

Multicast Policy Name :  [Create Multicast Policy](#)

Common/Global  Fabric A  Fabric B  Both Fabrics Configured Differently

You are creating global VLANs that map to the same VLAN IDs in all available fabrics.  
Enter the range of VLAN IDs.(e.g. "2009-2019", "29,35,40-45", "23", "23,34-45")

VLAN IDs :

Sharing Type :  None  Primary  Isolated  Community

## 20. Create VLAN for MapR-02.

## Create VLANs

VLAN Name/Prefix :

Multicast Policy Name :  [Create Multicast Policy](#)

Common/Global  Fabric A  Fabric B  Both Fabrics Configured Differently

You are creating global VLANs that map to the same VLAN IDs in all available fabrics.  
Enter the range of VLAN IDs.(e.g. "2009-2019", "29,35,40-45", "23", "23,34-45")

VLAN IDs :

Sharing Type :  None  Primary  Isolated  Community

## Create VLAN Groups

For easier management and bandwidth allocation to a dedicated uplink on the Fabric Interconnect, VLAN Groups are created within the Cisco UCS. SAP HANA uses the following VLAN groups:

- Admin Zone
- Client Zone
- Internal Zone
- Backup Network
- Replication Network

To configure the necessary VLAN Groups for the Cisco UCS environment, complete the following steps:

1. In Cisco UCS Manager, click the LAN tab in the navigation pane.





In this procedure, five VLAN Groups are created. Based on the solution requirement create VLAN groups, it not required to create all five VLAN groups.

2. Select LAN > LAN Cloud.
3. Right-click VLAN Groups.
4. Select Create VLAN Groups.
5. Enter Admin-Zone as the name of the VLAN Group used for Infrastructure network.
6. Select Management.

**Create VLAN Group** ? X

Name:

VLANs

Advanced Filter Export Print No Native VLAN

Select	Name	Native VLAN
<input type="checkbox"/>	HANA-Client	<input type="radio"/>
<input type="checkbox"/>	HANA-DataSource	<input type="radio"/>
<input type="checkbox"/>	HANA-Internal	<input type="radio"/>
<input type="checkbox"/>	HANA-Replication	<input type="radio"/>
<input type="checkbox"/>	HANA-Storage	<input type="radio"/>
<input checked="" type="checkbox"/>	Management	<input type="radio"/>

Create VLAN

7. Click Next.
8. Click Next on Add Uplink Ports.
9. Choose the port-channels created for the Admin Network.

**Create VLAN Group**

1 Select VLANs  
2 Add Uplink Ports  
3 Add Port Channels

Port Channels		
Name	Fabric ID	ID
N3k-U...	A	5
N3k-U...	B	6

>>  
<<

Selected Port Channels		
Name	Fabric ID	ID
vPC-31-Nexus	A	31
vPC-32-Nexus	B	32

< Prev   Next >   **Finish**   Cancel

10. Click Finish.
11. Follow the steps 1-10 for each VLAN Group.
12. Select Create VLAN Groups.
13. Enter Internal-Zone as the name of the VLAN Group used for Internal network.
14. Select HANA-Internal, HANA-Storage, MapR-01, MapR-02, NFS-IPMI.

**1** Select VLANs

**2** Add Uplink Ports

**3** Add Port Channels

### Create VLAN Group

Name : Internal-Zone

VLANs

Advanced Filter Export Print No Native VLAN

Select	Name	Native VLAN
<input checked="" type="checkbox"/>	HANA-Internal	<input type="radio"/>
<input type="checkbox"/>	HANA-Replication	<input type="radio"/>
<input checked="" type="checkbox"/>	HANA-Storage	<input type="radio"/>
<input type="checkbox"/>	Management	<input type="radio"/>
<input checked="" type="checkbox"/>	MapR-01	<input type="radio"/>
<input checked="" type="checkbox"/>	MapR-02	<input type="radio"/>

Create VLAN

< Back Next > Finish Cancel

15. Click Next.

16. Click Next on Add Uplink Ports.

17. Choose the port-channels created for the Internal Zone.

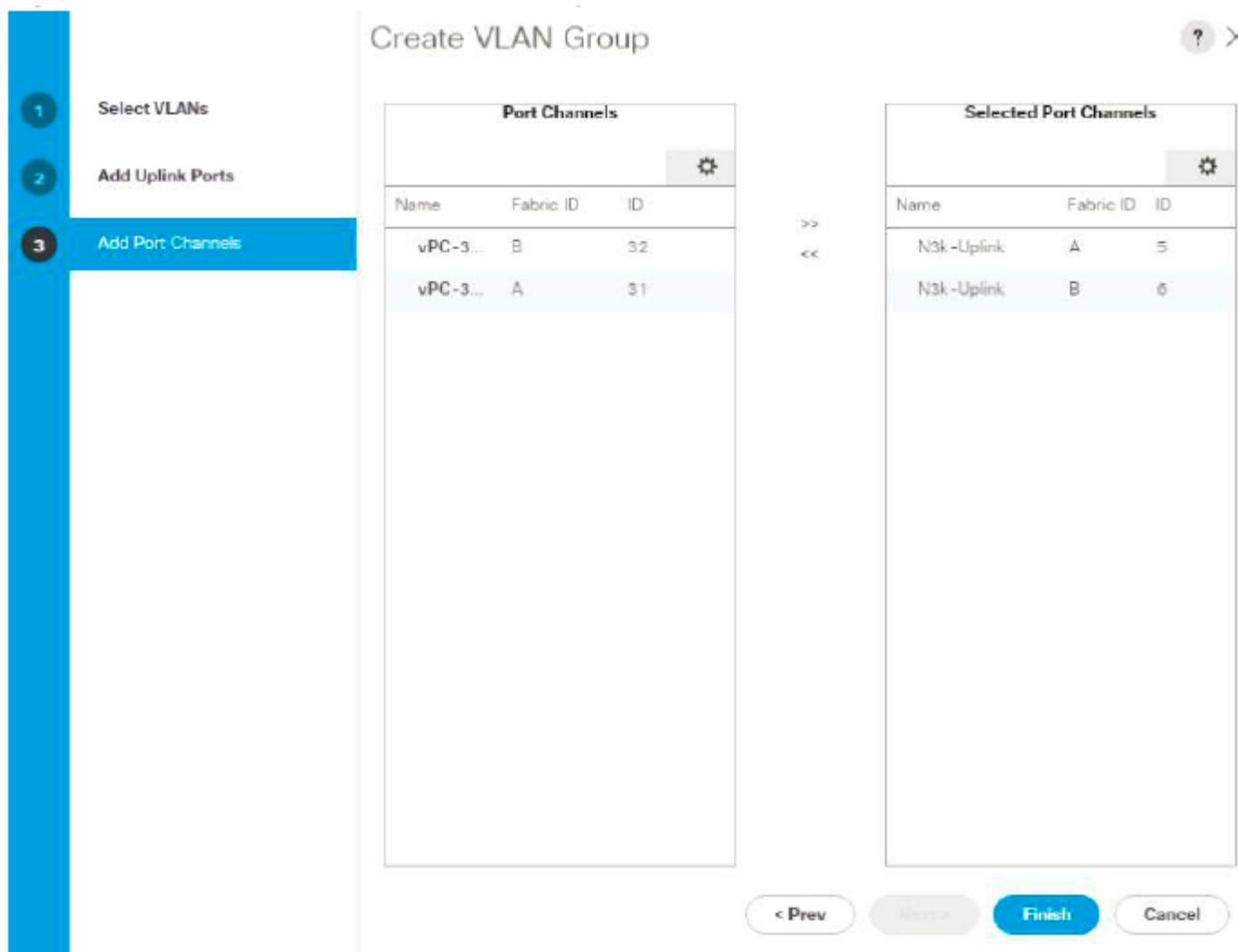

18. Click Finish.
19. Select Create VLAN Groups.
20. Enter Client-Zone as the name of the VLAN Group used for Client network.
21. Select HANA-AppServer, HANA-DataStore.
22. Click Next.
23. Click Next on Add Uplink Ports.
24. Choose port-channels created for Client Zone.
25. Click Finish.
26. Select Create VLAN Groups.
27. Enter Backup-Network as the name of the VLAN Group used for Backup Network.
28. Select HANA-Backup.

29. Click Next.
30. Click Next on Add Uplink Ports, since you will use Port Channel.
31. Choose the port-channels created for Backup Network.
32. Click Finish.
33. Select Create VLAN Groups.
34. Enter Replication-Network as the name of the VLAN Group used for Replication Network.
35. Select HANA-Replication.
36. Click Next.
37. Click Next on Add Uplink Ports.
38. Choose the port channels created for Replication Network.
39. Click Finish.

LAN / LAN Cloud / VLAN Groups

VLAN Groups Events

+ - Advanced Filter Export Print

Name	Native VLAN	Native VLAN DN	Size	VLAN ID	Poolable DN
LAN Cloud					
VLAN Group Replication-Network			1		
VLAN HANA-Replication				225	fabric/lan/net-HANA-R...
VLAN Group Internal-Zone			5		
VLAN HANA-Internal				220	fabric/lan/net-HANA-In...
VLAN HANA-Storage				110	fabric/lan/net-HANA-St...
VLAN MapR-01				21	fabric/lan/net-MapR-01
VLAN MapR-02				22	fabric/lan/net-MapR-02
VLAN NFS-IPM				197	fabric/lan/net-NFS-IPM
VLAN Group Client-Zone			4		
VLAN DMZ				401	fabric/lan/net-DMZ
VLAN HANA-AppServer				223	fabric/lan/net-HANA-A...
VLAN HANA-Client				222	fabric/lan/net-HANA-Cl...
VLAN HANA-DataSource				224	fabric/lan/net-HANA-D...
VLAN Group Backup-Network			1		



For each VLAN Group a dedicated or shared Ethernet Uplink Port or Port Channel can be selected.

## Create vNIC Template

Each VLAN is mapped to a vNIC template to specify the characteristic of a specific network. The vNIC template configuration settings include MTU size, Failover capabilities and MAC-Address pools.

To create vNIC templates for the Cisco UCS environment, complete the following steps:

1. In Cisco UCS Manager, click the LAN tab in the navigation pane.
2. Select Policies > root > Sub-Organization > HANA.
3. Right-click vNIC Templates.
4. Select Create vNIC Template.
5. Enter HANA-Internal as the vNIC template name.
6. Keep Fabric A selected.
7. Check the Enable Failover checkbox.
8. Under Target, make sure that the VM checkbox is unchecked.
9. Select Updating Template as the Template Type.
10. Under VLANs, check the checkboxes for HANA-Internal.
11. Set HANA-Internal as the native VLAN.
12. For MTU, enter 9000.
13. In the MAC Pool list, select FI-A.
14. For Network Control Policy Select Internal from drop-down list.

## Create vNIC Template



Name : HANA-Internal

Description :

Fabric ID :  Fabric A Fabric B Enable Failover

## Redundancy

Redundancy Type :  No Redundancy  Primary Template  Secondary Template

## Target

 Adapter  
 VM

## Warning

If **VM** is selected, a port profile by the same name will be created.

If a port profile of the same name exists, and updating template is selected, it will be overwritten

Template Type :  Initial Template  Updating Template

## VLANs

## VLAN Groups

 Advanced Filter        

Select	Name	Native VLAN
<input checked="" type="checkbox"/>	HANA-Internal	<input checked="" type="radio"/>
<input type="checkbox"/>	HANA-Replication	<input type="radio"/>

OK

Cancel

## Create vNIC Template



SELECT	INTERFACE	ASSOCIATE VLAN
<input checked="" type="checkbox"/>	HANA-Internal	<input checked="" type="radio"/>
<input type="checkbox"/>	HANA-Replication	<input type="radio"/>
<input type="checkbox"/>	HANA-Storage	<input type="radio"/>
<input type="checkbox"/>	Management	<input type="radio"/>
<input type="checkbox"/>	MapR-01	<input type="radio"/>

**Create VLAN**

CDN Source :  vNIC Name  User Defined

MTU :

MAC Pool :

QoS Policy :

Network Control Policy :

Pin Group :

Stats Threshold Policy :

**Connection Policies**

Dynamic vNIC  usNIC  VMQ

Dynamic vNIC Connection Policy :

**OK** **Cancel**

- Click OK to create the vNIC template.



For most SAP HANA use cases the network traffic is well distributed across the two Fabrics (Fabric A and Fabric B) using the default setup. In special cases, it can be required to rebalance this distribution for better overall performance. This can be done in the vNIC template with the Fabric ID setting. Note that the MTU settings must match the configuration in customer data center. MTU setting of 9000 is recommended for best performance.

- Follow the steps 1-15 above to create vNIC template for each Network Interface.

## Create a vNIC Template for Storage Network

- In Cisco UCS Manager, click the LAN tab in the navigation pane.



2. Select Policies > root > Sub-Organization > HANA.
3. Right-click vNIC Templates.
4. Select Create vNIC Template.
5. Enter HANA-Storage as the vNIC template name.
6. Keep Fabric B selected.
7. Check the Enable Failover checkbox.
8. Under Target, make sure that the VM checkbox is unchecked.
9. Select Updating Template as the Template Type.
10. Under VLANs, check the checkboxes for HANA-Storage.
11. Set HANA-Storage as the native VLAN.
12. For MTU, enter 9000.
13. In the MAC Pool list, select FI-B.
14. For Network Control Policy Select Internal from drop-down list.
15. Click OK to create the vNIC template.

### Create a vNIC Template for AppServer Network

1. In Cisco UCS Manager, click the LAN tab in the navigation pane.
2. Select Policies > root > Sub-Organization > HANA.
3. Right-click vNIC Templates.
4. Select Create vNIC Template.
5. Enter HANA-AppServer as the vNIC template name.
6. Keep Fabric A selected.
7. Check the Enable Failover checkbox.
8. Under Target, make sure that the VM checkbox is unchecked.
9. Select Updating Template as the Template Type.
10. Under VLANs, check the checkboxes for HANA-AppServer.
11. Set HANA-AppServer as the native VLAN.
12. For MTU, enter 9000.
13. In the MAC Pool list, select FI-A.

14. For Network Control Policy Select default from drop-down list.
15. Click OK to create the vNIC template.

### Create a vNIC Template for Backup Network

1. In Cisco UCS Manager, click the LAN tab in the navigation pane.
2. Select Policies > root > Sub-Organization > HANA.
3. Right-click vNIC Templates
4. Select Create vNIC Template.
5. Enter HANA-Backup as the vNIC template name.
6. Keep Fabric B selected.
7. Check the Enable Failover checkbox.
8. Under Target, make sure that the VM checkbox is unchecked.
9. Select Updating Template as the Template Type.
10. Under VLANs, check the checkboxes for HANA-Backup.
11. Set HANA-Backup as the native VLAN.
12. For MTU, enter 9000.
13. In the MAC Pool list, select FI-B.
14. For Network Control Policy Select default from drop-down list.
15. Click OK to create the vNIC template.

### Create a vNIC Template for Client Network

1. In Cisco UCS Manager, click the LAN tab in the navigation pane.
2. Select Policies > root > Sub-Organization > HANA.
3. Right-click vNIC Templates.
4. Select Create vNIC Template.
5. Enter HANA-Client as the vNIC template name.
6. Keep Fabric B selected.
7. Check the Enable Failover checkbox.
8. Under Target, make sure that the VM checkbox is unchecked.
9. Select Updating Template as the Template Type.

10. Under VLANs, check the checkboxes for HANA-Client.
11. Set HANA-Client as the native VLAN.
12. For MTU, enter 9000.
13. In the MAC Pool list, select FI-B.
14. For Network Control Policy Select default from drop-down list.
15. Click OK to create the vNIC template.

### Create a vNIC Template for DataSource Network

1. In Cisco UCS Manager, click the LAN tab in the navigation pane.
2. Select Policies > root > Sub-Organization > HANA.
3. Right-click vNIC Templates.
4. Select Create vNIC Template.
5. Enter HANA-DataSource as the vNIC template name.
6. Keep Fabric A selected.
7. Check the Enable Failover checkbox.
8. Under Target, make sure that the VM checkbox is unchecked.
9. Select Updating Template as the Template Type.
10. Under VLANs, check the checkboxes for HANA-DataSource.
11. Set HANA-DataSource as the native VLAN.
12. For MTU, enter 9000.
13. In the MAC Pool list, select FI-A.
14. For Network Control Policy Select default from drop-down list.
15. Click OK to create the vNIC template.

### Create a vNIC Template for Replication Network

1. In Cisco UCS Manager, click the LAN tab in the navigation pane.
2. Select Policies > root > Sub-Organization > HANA.
3. Right-click vNIC Templates.
4. Select Create vNIC Template.
5. Enter HANA-Replication as the vNIC template name.

6. Keep Fabric B selected.
7. Check the Enable Failover checkbox.
8. Under Target, make sure that the VM checkbox is unchecked.
9. Select Updating Template as the Template Type.
10. Under VLANs, check the checkboxes for HANA-Replication.
11. Set HANA-Replication as the native VLAN.
12. For MTU, enter 9000.
13. In the MAC Pool list, select FI-B.
14. For Network Control Policy Select default from drop-down list.
15. Click OK to create the vNIC template.

### Create a vNIC Template for Management Network

1. In Cisco UCS Manager, click the LAN tab in the navigation pane.
2. Select Policies > root > Sub-Organization > HANA.
3. Right-click vNIC Templates.
4. Select Create vNIC Template.
5. Enter Mgmt as the vNIC template name.
6. Keep Fabric A selected.
7. Check the Enable Failover checkbox.
8. Under Target, make sure that the VM checkbox is unchecked.
9. Select Updating Template as the Template Type.
10. Under VLANs, check the checkboxes for Management.
11. Set Management as the native VLAN.
12. For MTU, enter 9000.
13. In the MAC Pool list, select FI-A.
14. For Network Control Policy Select default from drop-down list.
15. Click OK to create the vNIC template.

### Create a vNIC Template for IPMI Inband Access Network

1. In Cisco UCS Manager, click the LAN tab in the navigation pane.

2. Select Policies > root > Sub-Organization > HANA.
3. Right-click vNIC Templates.
4. Select Create vNIC Template.
5. Enter NFS-IPMI as the vNIC template name.
6. Keep Fabric A selected.
7. Check the Enable Failover checkbox.
8. Under Target, make sure that the VM checkbox is unchecked.
9. Select Updating Template as the Template Type.
10. Under VLANs, check the checkboxes for NFS-IPMI.
11. Set NFS-IPMI as the native VLAN.
12. For MTU, enter 9000.
13. In the MAC Pool list, select FI-A.
14. For Network Control Policy Select Internal from drop-down list.
15. Click OK to create the vNIC template.

### Create a vNIC Template for MapR-01 Internal Network

1. In Cisco UCS Manager, click the LAN tab in the navigation pane.
2. Select Policies > root > Sub-Organization > HANA.
3. Right-click vNIC Templates.
4. Select Create vNIC Template.
5. Enter MapR-01 as the vNIC template name.
6. Keep Fabric A selected.
7. Check the Enable Failover checkbox.
8. Under Target, make sure that the VM checkbox is unchecked.
9. Select Updating Template as the Template Type.
10. Under VLANs, check the checkboxes for MapR-01.
11. Set MapR-01 as the native VLAN.
12. For MTU, enter 9000.
13. In the MAC Pool list, select FI-A.

14. For Network Control Policy Select Internal from drop-down list.
15. Click OK to create the vNIC template.

### Create a vNIC template for MapR-02 Internal Network

1. In Cisco UCS Manager, click the LAN tab in the navigation pane.
2. Select Policies > root > Sub-Organization > HANA.
3. Right-click vNIC Templates.
4. Select Create vNIC Template.
5. Enter MapR-02 as the vNIC template name.
6. Keep Fabric B selected.
7. Check the Enable Failover checkbox.
8. Under Target, make sure that the VM checkbox is unchecked.
9. Select Updating Template as the Template Type.
10. Under VLANs, check the checkboxes for MapR-02.
11. Set MapR-02 as the native VLAN.
12. For MTU, enter 9000.
13. In the MAC Pool list, select FI-B.
14. For Network Control Policy Select Internal from drop-down list.
15. Click OK to create the vNIC template.

### Create Boot Policies

To create Local boot policies, complete the following steps:

1. In Cisco UCS Manager, click the Servers tab in the navigation pane.
2. Select Policies > root > Sub-Organization > HANA.
3. Right-click Boot Policies.
4. Select Create Boot Policy.
5. Enter Local-Boot as the name of the boot policy.
6. (Optional) Enter a description for the boot policy.
7. Expand the Local Devices drop-down list and select Add CD/DVD.
8. Expand the Local Devices drop-down list and select Add Local Disk.

- Click OK to save the boot policy.

## Create Boot Policy

Name :

Description :

Reboot on Boot Order Change :

Enforce vNIC/vHBA/iSCSI Name :

Boot Mode :  Legacy  Uefi

### WARNINGS:

The type (primary/secondary) does not indicate a boot order presence.

The effective order of boot devices within the same device class (LAN/Storage/iSCSI) is determined by PCIe bus scan order.

If **Enforce vNIC/vHBA/iSCSI Name** is selected and the vNIC/vHBA/iSCSI does not exist, a config error will be reported.

If it is not selected, the vNICs/vHBAs are selected if they exist, otherwise the vNIC/vHBA with the lowest PCIe bus scan order is used.

**Local Devices**

Add Local Disk

- Add Local LUN
- Add Local JBOD
- Add SD Card
- Add Internal USB
- Add External USB
- Add Embedded Local LUN
- Add Embedded Local Disk

Add CD/DVD

- Add Local CD/DVD
- Add Remote CD/DVD

**Boot Order**

+ - Advanced Filter Export Print

Name	Order	vNIC/v...	Type	WWN	LUN N...	Slot N...	Boot N...	Boot P...	Descri...
CD/DVD	1								
Local Disk	2								

Move Up Move Down Delets

Get More Boot Parameters

## Create IP Pool for Inband Management

For SAP HANA High Availability configuration, we would be using IPMI tool, create a block of IP addresses for SAP HANA servers. In the Cisco UCS environment, complete the following steps:



This block of IP addresses should be in the same subnet as the HANA-Admin IP addresses of the HANA Servers.

- In Cisco UCS Manager, click the LAN tab in the navigation pane.
- Select Pools > root > > Sub-Organization > HANA > IP Pools, right-click Create a IP Pool.
- For the Name enter HANA\_IPMI.
- For Assignment order select Sequential and click Next.
- Click Add.
- Enter the starting IP address of the block and the number of IP addresses required, and the subnet and gateway information.
- Click OK to create the IP block.

- Click OK in the confirmation message.

## Configure the Inband Profile

To allocate the previously configured IPv4 Address Pool, VLAN, and VLAN Group to the global Inband Profile, complete the following steps:

- In Cisco UCS Manager, click the LAN tab in the navigation pane.
- Select LAN Cloud, on the right pane click the Global Policies tab.
- On the Global Policies page, under the Inband Profile section:
- For Inband VLAN Group select Internal-Zone from the drop-down list.
- For Network select NFS-IPMI from the drop-down list.
- For IP Pool Name select HANA-IPMI from the drop-down list.
- Click Save Changes.

LAN / LAN Cloud

LAN Uplinks   VLANs   Server Links   MAC Identity Assignment   IP Identity Assignment   QoS   **Global Policies**   Faults   Events   FSM

---

Actions

---

Use Global for InBand Profile

---

Properties

---

MAC Address Table Aging

Aging Time :  Never  Mode Default  other

---

VLAN Port Count

VLAN Port Count Optimization :  Enabled  Disabled

---

Org Permissions

Org Permissions :  Enabled  Disabled

---

Inband Profile

Owner : **Local**

Inband VLAN Group :  ▼

Network :  ▼

IP Pool Name :  ▼

## Create Service Profile Templates for SAP HANA Scale-Out Servers

The LAN configurations and relevant SAP HANA policies must be defined prior to creating, a Service Profile Template.

To create the service profile template, complete the following steps:

- In Cisco UCS Manager, click the Servers tab in the navigation pane.



2. Select Service Profile Templates > root > Sub-Organization > HANA.
3. Right-click HANA.
4. Select Create Service Profile Template to open the Create Service Profile Template wizard.
5. Identify the service profile template:
  - a. Enter HANA-Server as the name of the service profile template.
  - b. Select the Updating Template option.
  - c. Under UUID, select HANA-UUID as the UUID pool.
  - d. Click Next.

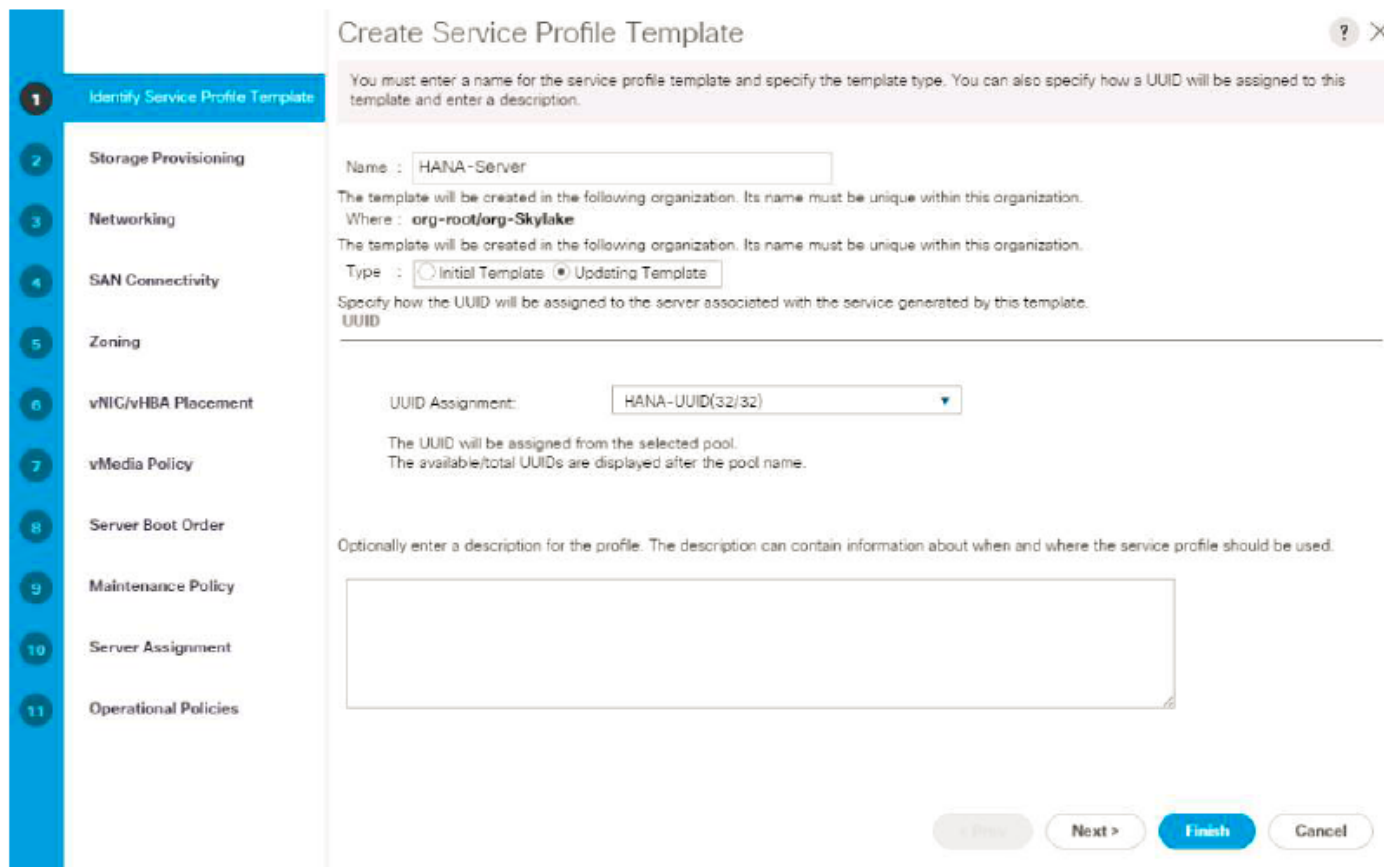

6. Configure the Storage Provisioning:
  - a. Click the Local Disk Configuration Policy tab.
  - b. Select RAID1 for Local Storage field from the drop-down list.
  - c. Click Next.

**Create Service Profile Template**

Optionally specify or create a Storage Profile, and select a local disk configuration policy.

Specific Storage Profile    Storage Profile Policy    **Local Disk Configuration Policy**

Local Storage: RAID1 ▼

[Create Local Disk Configuration Policy](#)

Mode : **RAID 1 Mirrored**

Protect Configuration : **Yes**

If **Protect Configuration** is set, the local disk configuration is preserved if the service profile is disassociated with the server. In that case, a configuration error will be raised when a new service profile is associated with that server if the local disk configuration in that profile is different.

**FlexFlash**

FlexFlash State : **Disable**

If **FlexFlash State** is disabled, SD cards will become unavailable immediately. Please ensure SD cards are not in use before disabling the FlexFlash State.

FlexFlash RAID Reporting State : **Disable**

< Prev    Next >    **Finish**    Cancel

7. Configure the Networking options:

- a. Keep the default settings for Dynamic vNIC Connection Policy.
- b. Select the Expert option for How would you like to configure LAN connectivity.
- c. Click the Add button to add a vNIC to the template.
- d. In the Create vNIC dialog box, enter HANA-Internal as the name of the vNIC.
- e. Check the Use vNIC Template checkbox.
- f. In the vNIC Template list, select HANA-Internal.
- g. In the Adapter Policy list, select Linux.
- h. Click OK to add this vNIC to the template.

## Create vNIC

Name :

Use vNIC Template :

Redundancy Pair :

vNIC Template :

Peer Name :

[Create vNIC Template](#)

---

Adapter Performance Profile

Adapter Policy :

[Create Ethernet Adapter Policy](#)

- i. Repeat the above steps c-h for each vNIC.
8. Add vNIC for HANA-Storage.
9. Add vNIC for HANA-Client.
10. Add vNIC for HANA-AppServer.
11. Add vNIC for HANA-DataSource.
12. Add vNIC for HANA-Replication.
13. Add vNIC for HANA-Backup.
14. Add vNIC for Mgmt.
15. Add vNIC for NFS-IPMI.
16. Review the table in the Networking page to make sure that all vNICs were created.

1 Identify Service Profile Template

2 Storage Provisioning

3 **Networking**

4 SAN Connectivity

5 Zoning

6 vNIC/vHBA Placement

7 vMedia Policy

8 Server Boot Order

9 Maintenance Policy

10 Server Assignment

11 Operational Policies

### Create Service Profile Template

Optionally specify LAN configuration information.

Dynamic vNIC Connection Policy:

[Create Dynamic vNIC Connection Policy](#)

---

How would you like to configure LAN connectivity?

Simple  Expert  No vNICs  Use Connectivity Policy

Click **Add** to specify one or more vNICs that the server should use to connect to the LAN.

Name	MAC Address	Fabric ID	Native VLAN
vNIC HANA-Storage	Derived	derived	
vNIC HANA-Replication	Derived	derived	
vNIC HANA-DataSource	Derived	derived	
vNIC HANA-Client	Derived	derived	
vNIC HANA-Backup	Derived	derived	

[Delete](#) [Add](#) [Modify](#)

[+ iSCSI vNICs](#)

[< Prev](#) [Next >](#) [Finish](#) [Cancel](#)

17. Click Next.

18. Configure the SAN Connectivity, Select the No vHBAs option for the “How would you like to configure SAN connectivity?” field.

19. Click Next.

20. Set no Zoning options and click Next.

21. Set the vNIC/vHBA placement options:

- a. In the Select Placement list, select the Specify Manually.
- b. Select vCon1 and assign the vNICs to the virtual network interfaces policy in the following order:
  - i. HANA-Storage
  - ii. HANA-AppServer
  - iii. HANA-Backup
  - iv. Mgmt

## Create Service Profile Template

Specify how vNICs and vHBAs are placed on physical network adapters

vNIC/vHBA Placement specifies how vNICs and vHBAs are placed on physical network adapters (mezzanine) in a server hardware configuration independent way.

Select Placement:  [Create Placement Policy](#)

**vNICs** | vHBAs

Name

- HANA-Client
- HANA-DataSource
- HANA-Internal
- HANA-Replication
- NFS-IPMI

>> assign >>

<< remove <<

Specific Virtual Network Interfaces (click on a cell to edit)

Name	Order	Select...	Admin ...
vCon 1			
All			
vNIC HANA-Storage	1		ANY
vNIC HANA-AppServer	2		ANY
vNIC HANA-Backup	3		ANY
vNIC Mgmt	4		ANY
vCon 2			
All			
<span style="color: green;">↑</span> Move Up <span style="color: red;">↓</span> Move Down			

< Prev Next > Finish Cancel

- c. Select vCon2 and assign the vNICs to the virtual network interfaces policy in the following order:
- i. HANA-Internal
  - ii. HANA-Client
  - iii. HANA-DataSource
  - iv. HANA-Replication
  - v. NFS-IPMI

The screenshot shows the 'Create Service Profile Template' wizard. The left sidebar lists 11 steps, with step 6, 'vNIC/vHBA Placement', highlighted. The main area is titled 'Specify how vNICs and vHBAs are placed on physical network adapters'. Below this, there's a 'Select Placement' dropdown set to 'Specify Manually' and a 'Create Placement Policy' button. A tabbed interface shows 'vNICs' selected, with a 'Name' field containing 'No data available'. To the right, a table titled 'Specific Virtual Network Interfaces (click on a cell to edit)' lists vNICs under the 'vCon 2' policy. The table has columns for Name, Order, Select, and Admin. The vNICs listed are: vNIC HANA-Internal (Order 1), vNIC HANA-Client (Order 2), vNIC HANA-DataSource (Order 3), vNIC HANA-Replication (Order 4), and vNIC NFS-IPMI (Order 5). At the bottom of the table are 'Move Up' and 'Move Down' icons. Navigation buttons at the bottom right include '< Prev', 'Next >', 'Finish', and 'Cancel'.

- d. Review the table to verify that all vNICs are assigned to the policy in the appropriate order.
  - e. Click Next.
22. No Change required on the vMedia Policy, click Next.
23. Set the server boot order:
- a. Select Local-Boot for Boot Policy.

1 Identify Service Profile Template

2 Storage Provisioning

3 Networking

4 SAN Connectivity

5 Zoning

6 vNIC/vHBA Placement

7 vMedia Policy

8 **Server Boot Order**

9 Maintenance Policy

10 Server Assignment

11 Operational Policies

### Create Service Profile Template

Optionally specify the boot policy for this service profile template.

Select a boot policy.

Boot Policy:  [Create Boot Policy](#)

Name: **Local-Boot**

Description:

Reboot on Boot Order Change: **No**

Enforce vNIC/vHBA/iSCSI Name: **Yes**

Boot Mode: **Legacy**

**WARNINGS:**  
 The type (primary/secondary) does not indicate a boot order presence.  
 The effective order of boot devices within the same device class (LAN/Storage/iSCSI) is determined by PCIe bus scan order.  
 If **Enforce vNIC/vHBA/iSCSI Name** is selected and the vNIC/vHBA/iSCSI does not exist, a config error will be reported.  
 If it is not selected, the vNICs/vHBAs are selected if they exist, otherwise the vNIC/vHBA with the lowest PCIe bus scan order is used.

**Boot Order**

Name	Order	vNIC/vHB...	Type	WWN	LUN Name	Slot Num...	Boot Name	Boot Path	Description
CD/DVD	1								
Local ...	2								

< Prev    Next >    **Finish**    Cancel

b. Click Next.

24. For Maintenance policy:

- Select the default Maintenance Policy.
- Click Next.

25. Specify the server assignment:

- Select Up as the power state to be applied when the profile is associated with the server.
- Expand Firmware Management at the bottom of the page and select HANA-FW from the Host Firmware list.
- Click Next.

**Create Service Profile Template** ? X

Optionally specify a server pool for this service profile template.

You can select a server pool you want to associate with this service profile template.

Pool Assignment:  [Create Server Pool](#)

Select the power state to be applied when this profile is associated with the server.

Up  Down

The service profile template is not automatically associated with a server. Either select a server from the list or associate the service profile manually later.

Firmware Management (BIOS, Disk Controller, Adapter)

If you select a host firmware policy for this service profile, the profile will update the firmware on the server that it is associated with. Otherwise the system uses the firmware already installed on the associated server.

Host Firmware Package:  [Create Host Firmware Package](#)

## 26. For Operational Policies:

- a. In the BIOS Policy list, select HANA-BIOS.
- b. Expand the External IPMI Management Configuration and select HANA-IPMI in the IPMI Access Profile.
- c. Select SoL-Console in the SoL Configuration Profile.
- d. Expand Management IP Address,
- e. In the Outband IPv4 tab choose ext-mgmt in the Management IP Address Policy.
- f. In the Inband IPv4 tab choose NFS-IPMI for Network and choose HANA-IPMI for Management IP Address Policy.



Management IP Address

Outband IPv4 **Inband**

Network : NFS-IPMI

**Inband IPv4** Inband IPv6

Management IP Address Policy: HANA\_IPMI(14/48)

IP Address : 0.0.0.0  
 Subnet Mask : 255.255.255.0  
 Default Gateway : 0.0.0.0  
 Primary DNS : 0.0.0.0  
 Secondary DNS : 0.0.0.0

The IP address will be automatically assigned from the selected pool.

Create IP Pool

27. Expand Power Control Policy Configuration and select No-Power-Cap in the Power Control Policy list.

Create Service Profile Template

Optionally specify information that affects how the system operates.

BIOS Configuration

If you want to override the default BIOS settings, select a BIOS policy that will be associated with this service profile

BIOS Policy : HANA-BIOS

External IPMI Management Configuration

If you want to access the CIMC on the server externally, select an IPMI access profile. The users and passwords in that profile will be populated into the CIMC when the profile is associated with the server.

IPMI Access Profile : HANA [Create IPMI Access Profile](#)

To enable Serial over LAN access to the server, select an SoL configuration profile.

SoL Configuration Profile : SoL [Create Serial over LAN Policy](#)

Name : SoL  
 Description :

Management IP Address

Monitoring Configuration (Thresholds)

< Prev Next **Finish** Cancel

28. Click Finish to create the service profile template.
29. Click OK in the confirmation message.

If you are using C480-M5 as HANA Servers, create the service profile template and modify the vNIC placement policy.

To create a clone service profile template created, complete the following steps:

1. In Cisco UCS Manager, click the Servers tab in the navigation pane.
2. Select Service Profile Templates > root > Sub-Organization > HANA.
3. Right-click Service Template HANA-Server.
4. Select Create a Clone.
5. Enter HANA-C480 for Clone name and Choose root as Org.
6. Click OK to Create the clone of HANA-C480.
7. Click OK to confirm.
8. On the cloned Service Profile Template Select HANA-C480 in the Navigation pane and click Network tab.
9. Under Actions Click Modify vNIC/vHBA Placement.
10. Select vCon1 and assign the vNICs to the virtual network interfaces policy in the following order:
  - a. HANA-Internal
  - b. HANA-Storage
  - c. HANA-AppServer
  - d. HANA-Client
  - e. Mgmt
  - f. HANA-Backup
  - g. HANA-DataSource
  - h. HANA-Replication
  - i. NFS-IPMI
11. Click OK to complete the vNIC/vHBA Placement policy.
12. Click OK to confirm.

## Create Service Profile from the Template

To create service profiles from the service profile template, complete the following steps:

1. In Cisco UCS Manager, click the Servers tab in the navigation pane.
2. Select Service Profile Templates > root > Sub-Organization > HANA > Service Template HANA-Server.
3. Right-click Service Template HANA-Server and select Create Service Profiles from Template.

4. Enter HANA-Server0 as the service profile prefix.
5. Enter 1 as Name Suffix Starting Number.
6. Enter 1 as the Number of Instances.
7. Click OK to create the service profile.

## Create Service Profiles From Template ? X

Naming Prefix :

Name Suffix Starting Number :

Number of Instances :

To create service profiles from the service profile template HANA-C480, complete the following steps:

1. In Cisco UCS Manager, click the Servers tab in the navigation pane.
2. Select Service Profile Templates > root > Sub-Organization > HANA > Service Template HANA-C480.
3. Right-click Service Template HANA-C480 and select Create Service Profiles from Template.
4. Enter HANA-Server0 as the service profile prefix.
5. Enter 2 as Name Suffix Starting Number.
6. Enter 1 as the Number of Instances.
7. Click OK to create the service profile.

To associate service profile created for a specific slot, complete the following steps:

1. In Cisco UCS Manager, click the Servers tab in the navigation pane.
2. Select Service Profile > root > Sub-Organization > HANA > HANA-Server01.
3. Right-click HANA-Server01 and select Change Service Profile Association.
4. For Server Assignment Choose Select existing Server for the drop-down list.
5. Click All Servers.
6. Select the Server as recommended.

- Repeat for above steps 1-6 for each HANA Servers.

## Create Service Profile Templates for MapR Servers

To create the service profile template, complete the following steps:

- In Cisco UCS Manager, click the Servers tab in the navigation pane.
- Select Service Profile Templates > root > Sub-Organization > HANA.
- Right-click HANA.
- Select Create Service Profile Template to open the Create Service Profile Template wizard.
- Identify the service profile template:
  - Enter MapR as the name of the service profile template.
  - Select the Updating Template option.
  - Under UUID, select HANA-UUID as the UUID pool.
  - Click Next.
- Configure the Storage Provisioning:
  - Click the Local Disk Configuration Policy tab.
  - Select MapR for Local Storage field from the drop-down list.
  - Click Next.

**Create Service Profile Template** ? X

Optionally specify or create a Storage Profile, and select a local disk configuration policy.

Specific Storage Profile    Storage Profile Policy    **Local Disk Configuration Policy**

Local Storage:

[Create Local Disk Configuration Policy](#)

Mode: **Any Configuration**

Protect Configuration: **Yes**

If **Protect Configuration** is set, the local disk configuration is preserved if the service profile is disassociated with the server. In that case, a configuration error will be raised when a new service profile is associated with that server if the local disk configuration in that profile is different.

**FlexFlash**

FlexFlash State: **Disable**

If **FlexFlash State** is disabled, SD cards will become unavailable immediately. Please ensure SD cards are not in use before disabling the FlexFlash State.

FlexFlash RAID Reporting State: **Disable**

7. Configure the Networking options:
  - a. Keep the default settings for Dynamic vNIC Connection Policy.
  - b. Select the Expert option for How would you like to configure LAN connectivity.
  - c. Click the Add button to add a vNIC to the template.
  - d. In the Create vNIC dialog box, enter MapR-01 as the name of the vNIC.
  - e. Check the Use vNIC Template checkbox.
  - f. In the vNIC Template list, select MapR-01
  - g. In the Adapter Policy list, select Linux.
  - h. Click OK to add this vNIC to the template.

### Create vNIC

Name :

Use vNIC Template :

Redundancy Pair :

Peer Name :

vNIC Template :

[Create vNIC Template](#)

---

Adapter Performance Profile

Adapter Policy :

[Create Ethernet Adapter Policy](#)

- i. Repeat the above steps c-h for each vNIC.
8. Add vNIC for MapR-02.
9. Add vNIC for HANA-Storage.
10. Add vNIC for Mgmt.
11. Review the table in the Networking page to make sure that all vNICs were created.

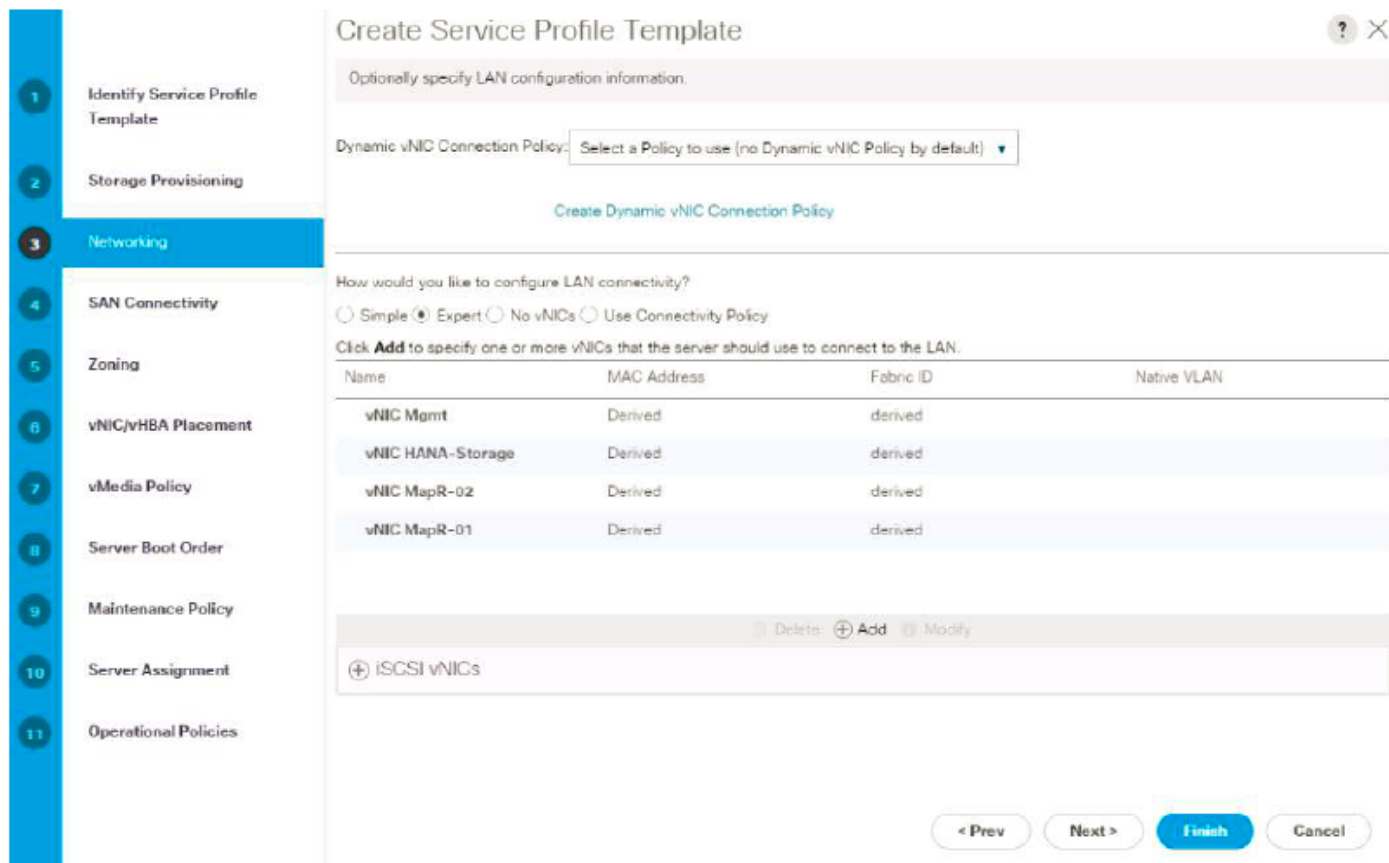

12. Click Next.
13. Configure the SAN Connectivity, Select the No vHBAs option for the “How would you like to configure SAN connectivity?” field.
14. Click Next.
15. Set no Zoning options and click Next.
16. Set the vNIC/vHBA placement options, keep the default values.
17. Rearrange the order, using Move Up and Move Down icons.

**Create Service Profile Template**

Specify how vNICs and vHBAs are placed on physical network adapters

vNIC/vHBA Placement specifies how vNICs and vHBAs are placed on physical network adapters (mezzanine) in a server hardware configuration independent way.

Select Placement:  [Create Placement Policy](#)

System will perform automatic placement of vNICs and vHBAs based on PCI order:

Name	Address	Order
vNIC MapR-01	Derived	1
vNIC MapR-02	Derived	2
<b>vNIC HANA-Storage</b>	Derived	3
vNIC Mgmt	Derived	4

18. Click Next.

19. Keep the default values on the vMedia Policy, click Next.

20. To set the server boot order, select Local-Boot for Boot Policy.

**Create Service Profile Template**

Optionally specify the boot policy for this service profile template.

Select a boot policy.

Boot Policy:  [Create Boot Policy](#)

Name : **Local-Boot**  
 Description :  
 Reboot on Boot Order Change : **No**  
 Enforce vNIC/vHBA/iSCSI Name : **Yes**  
 Boot Mode : **Legacy**

**WARNINGS:**  
 The type (primary/secondary) does not indicate a boot order presence.  
 The effective order of boot devices within the same device class (LAN/Storage/iSCSI) is determined by PCIe bus scan order.  
 If **Enforce vNIC/vHBA/iSCSI Name** is selected and the vNIC/vHBA/iSCSI does not exist, a config error will be reported.  
 If it is not selected, the vNICs/vHBAs are selected if they exist, otherwise the vNIC/vHBA with the lowest PCIe bus scan order is used.

**Boot Order**

Name	Order	vNIC/vHB...	Type	WWN	LUN Name	Slot Num...	Boot Name	Boot Path	Description
CD/DVD	1								
Local	2								

[Create Boot Policy](#) [Cancel Boot Policy](#) [Delete Boot Policy](#)

[< Prev](#) [Next >](#) [Finish](#) [Cancel](#)

21. Click Next.

22. For Maintenance policy: Select the default Maintenance Policy.

23. Click Next.

24. Specify the server assignment: Select Up as the power state to be applied when the profile is associated with the server.

25. Expand Firmware Management at the bottom of the page and select HANA-FW from the Host Firmware list.

26. Click Next.

27. For Operational policies, In the BIOS Policy list, select MapR-BIOS.

28. Expand Management IP Address, in the Outband IPv4 tab choose ext-mgmt in the Management IP Address Policy.

29. Expand Power Control Policy Configuration and select No-Power-Cap in the Power Control Policy list.



**Create Service Profile Template**

Optionally specify information that affects how the system operates.

⊖ BIOS Configuration

If you want to override the default BIOS settings, select a BIOS policy that will be associated with this service profile.

BIOS Policy:

⊕ External IPMI Management Configuration

⊕ Management IP Address

⊕ Monitoring Configuration (Thresholds)

⊖ Power Control Policy Configuration

Power control policy determines power allocation for a server in a given power group.

Power Control Policy:  [Create Power Control Policy](#)

⊕ Scrub Policy

⊕ KVM Management Policy

⊕ Graphics Card Policy

< Prev   Next >   **Finish**   Cancel

30. Click Finish to create the service profile template.

31. Click OK in the confirmation message.

## Create Service Profiles

To create service profiles from the service profile template, complete the following steps:

1. In Cisco UCS Manager, click the Servers tab in the navigation pane.
2. Select Service Profile Templates > root > Sub-Organization > HANA > Service Template MapR.
3. Right-click MapR and select Create Service Profiles from Template.
4. Enter appropriate name for the service profile prefix. For example, MapR-0.
5. Enter 1 as Name Suffix Starting Number.
6. Enter appropriate number of service profile to be created in the Number of Instances. For example, 4.
7. Click OK to create the service profile.

## Create Service Profiles From Template ? ×

Naming Prefix :

Name Suffix Starting Number :

Number of Instances :



To associate service profile created for a specific slot, complete the following steps:

1. In Cisco UCS Manager, click the Servers tab in the navigation pane.
2. Select Service Profile > root > Sub-Organization > HANA > MapR-01.
3. Right-click MapR-01 and select Change Service Profile Association.
4. For Server Assignment, choose Select existing Server from the drop-down list.
5. Click All Servers.
6. Select the C240-M5 Rack Mount Server Rack ID 1.
7. Repeat the above steps 1-6 for each MapR Server.

## MapR Storage Configuration

---

The section describes the procedure for Installing MapR Data Platform on Cisco UCS C240-M5 Servers. Each server has 2 x Internal SSD Boot drives where the Operating System is installed with RAID 1. For MapR Storage 24 x 1.8 TB 10k rpm 4K disks are configured in 4 x RAID 5 group with 6 disks.

### MapR Server RAID Configuration

To configure RAID on the Cisco UCS C240 Servers used for MapR Data Platform, complete the following steps:

1. In Cisco UCS Manager, click the Servers tab in the navigation pane.
2. Select Service Profile > root > Sub-Organization > HANA > MapR-01.
3. Click KVM Console.
4. When the KVM Console is launched, click Boot Server.



```
Cisco Systems, Inc.  
Configuring and testing memory..  
Configuring platform hardware...
```

UCSM

5. When prompted Press <Ctrl><R> to Run MegaRAID Configuration Utility.

```

ID   LUN  VENDOR  PRODUCT                REVISION  CAPACITY
---  ---  ---     ---                    ---        ---
49   0    HGST    HUC101B18CS4200      A703      1716957MB
50   0    ATA     INTEL SSDSC2BB15     CS01      143089MB
51   0    HGST    HUC101B18CS4200      A703      1716957MB

26 JBOD(s) found on the host adapter
2 JBOD(s) handled by BIOS

0 Virtual Drive(s) found on the host adapter.
0 Virtual Drive(s) handled by BIOS

Press <Ctrl><R> to Run MegaRAID Configuration Utility
    
```

6. In VD Mgmt Tab, highlight Cisco 12G Modular Raid Con and press F2 and Select Make Unconfigured Good.

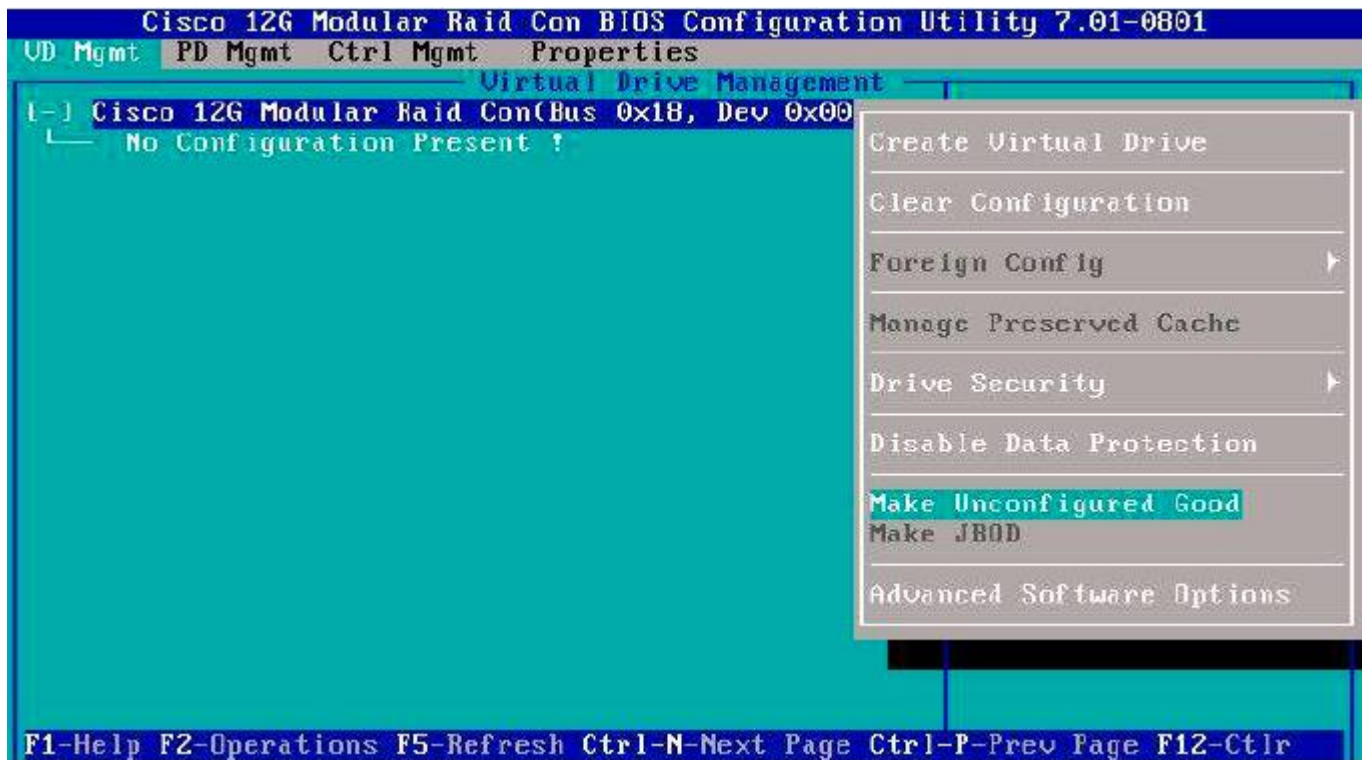

7. In the Convert JBODs to Unconfigured Good Select All JBOD Drives and Enter OK.

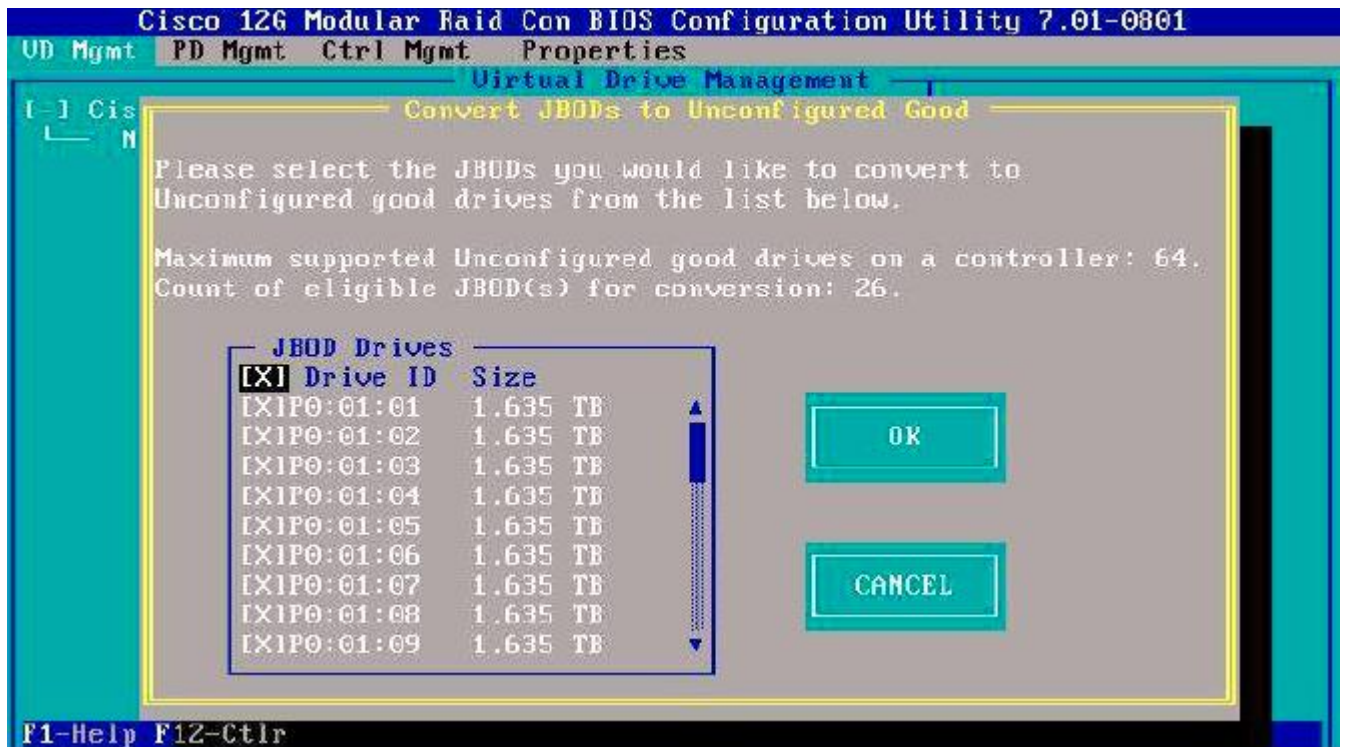

8. In the VD Mgmt press F2 for Operations and Select Create Virtual Drive.

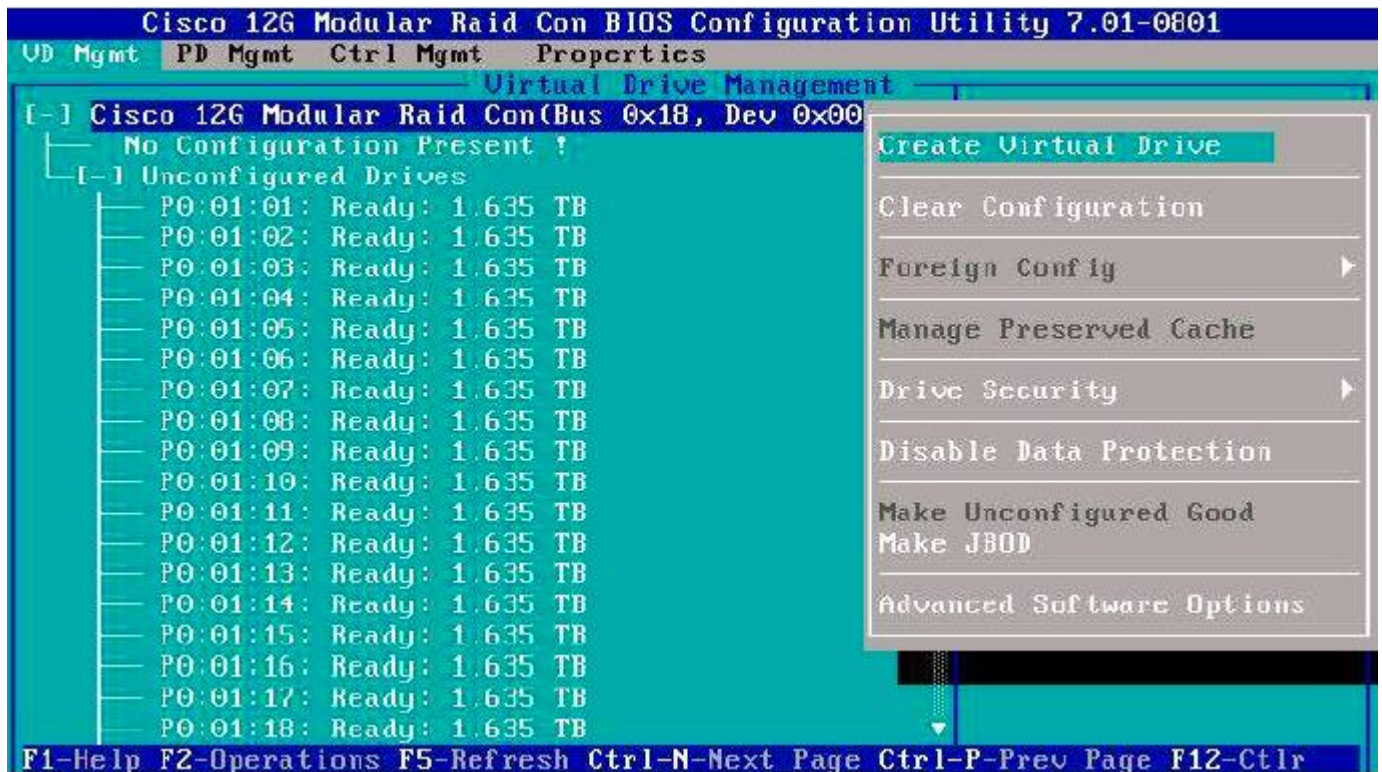

9. Choose the following option to create RAID 1 virtual drive with 2 disks for Boot:
  - a. For RAID Level Choose RAID-1.



- b. Choose the last two drives in Slot 25 and 26.
- c. Give a Name for virtual drive 0.

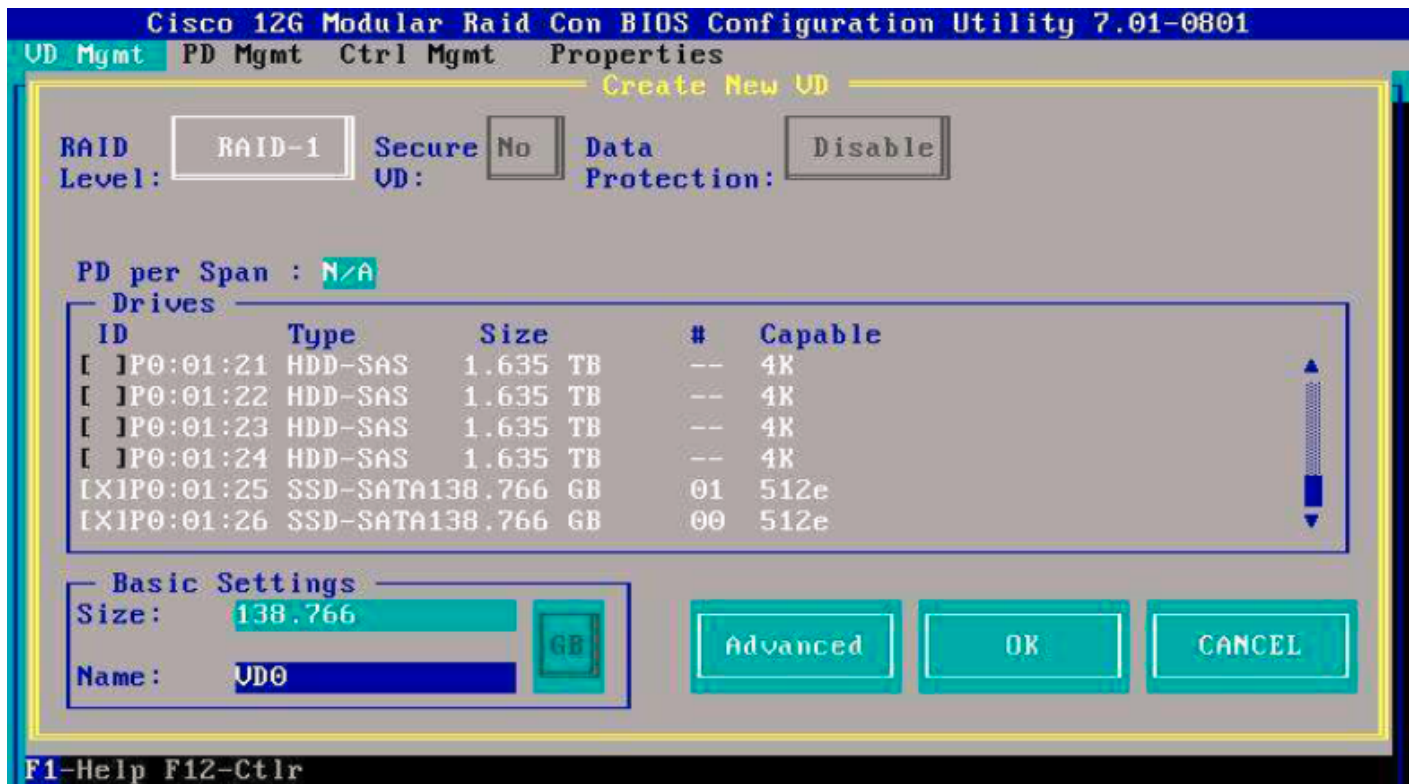

10. Choose Advanced option:
  - a. For Strip Size choose 1MB.
  - b. For Read Policy Choose Ahead.
  - c. For Write Policy choose Write Back with BBU.
  - d. For I/O Policy choose Direct.
  - e. Keep the Default Disk cache Policy and Emulation.
  - f. Choose Initialize.
  - g. Click OK.

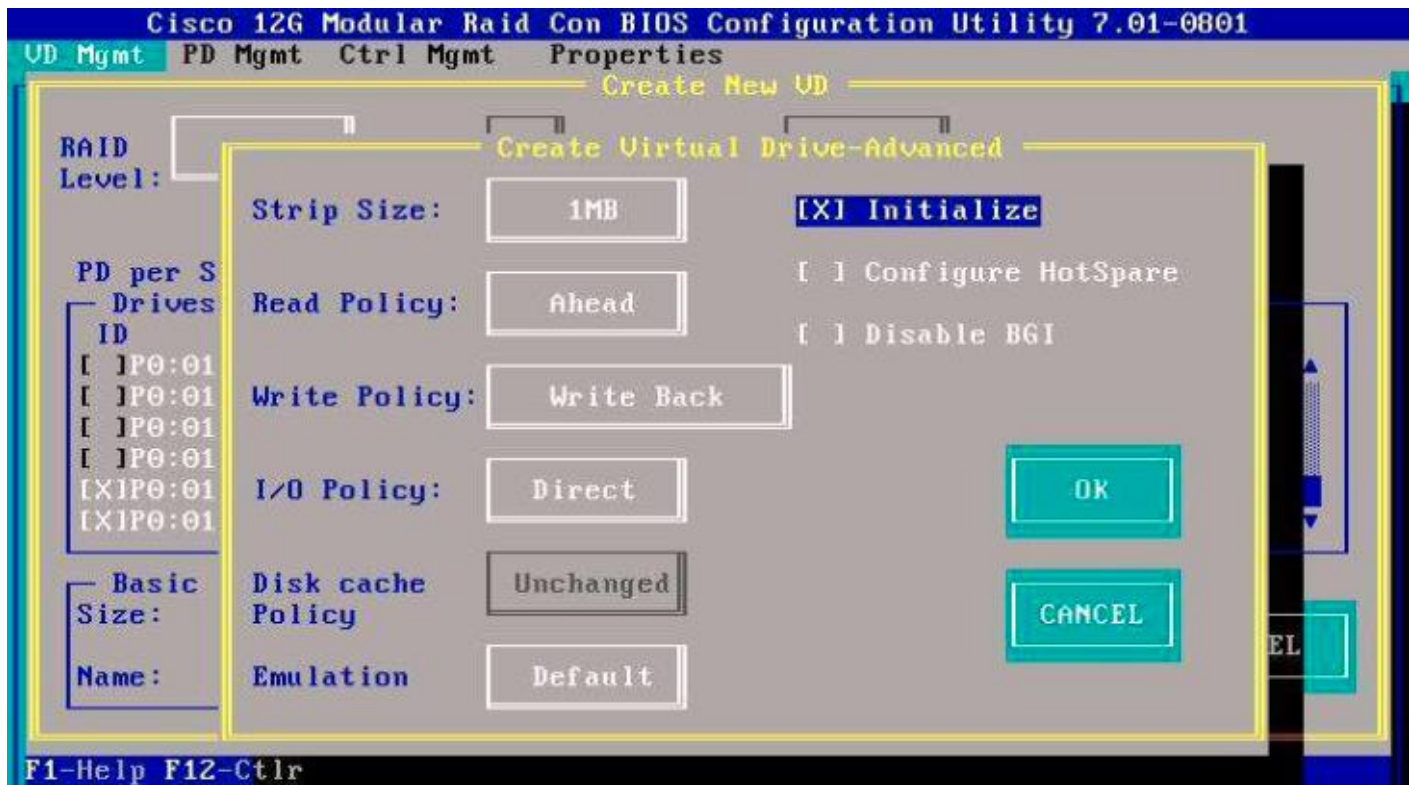

11. In the VD Mgmt press F2 for Operations and Select Create Virtual Drive.
12. Choose the following option to create RAID 5 virtual drive with 6 disks:
  - a. For RAID Level Choose RAID-5.
  - b. Choose the first 6 disks.
  - c. Give a Name for virtual drive 1.

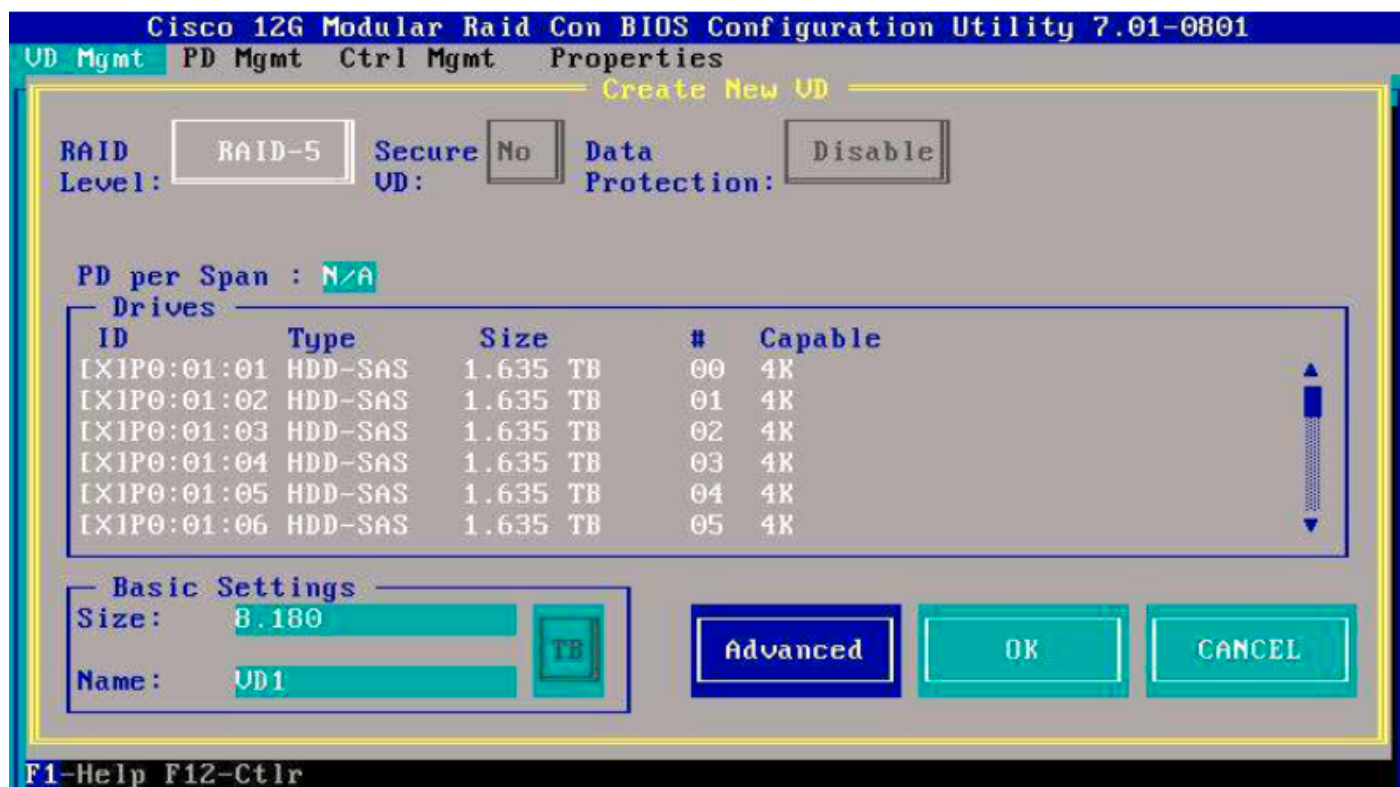

13. Choose Advanced option:

- a. For Strip Size choose 1MB.
- b. For Read Policy Choose Ahead.
- c. For Write Policy choose Write Back with BBU.
- d. For I/O Policy choose Direct.
- e. Keep the Default Disk cache Policy and Emulation.
- f. Choose Initialize.
- g. Click OK.



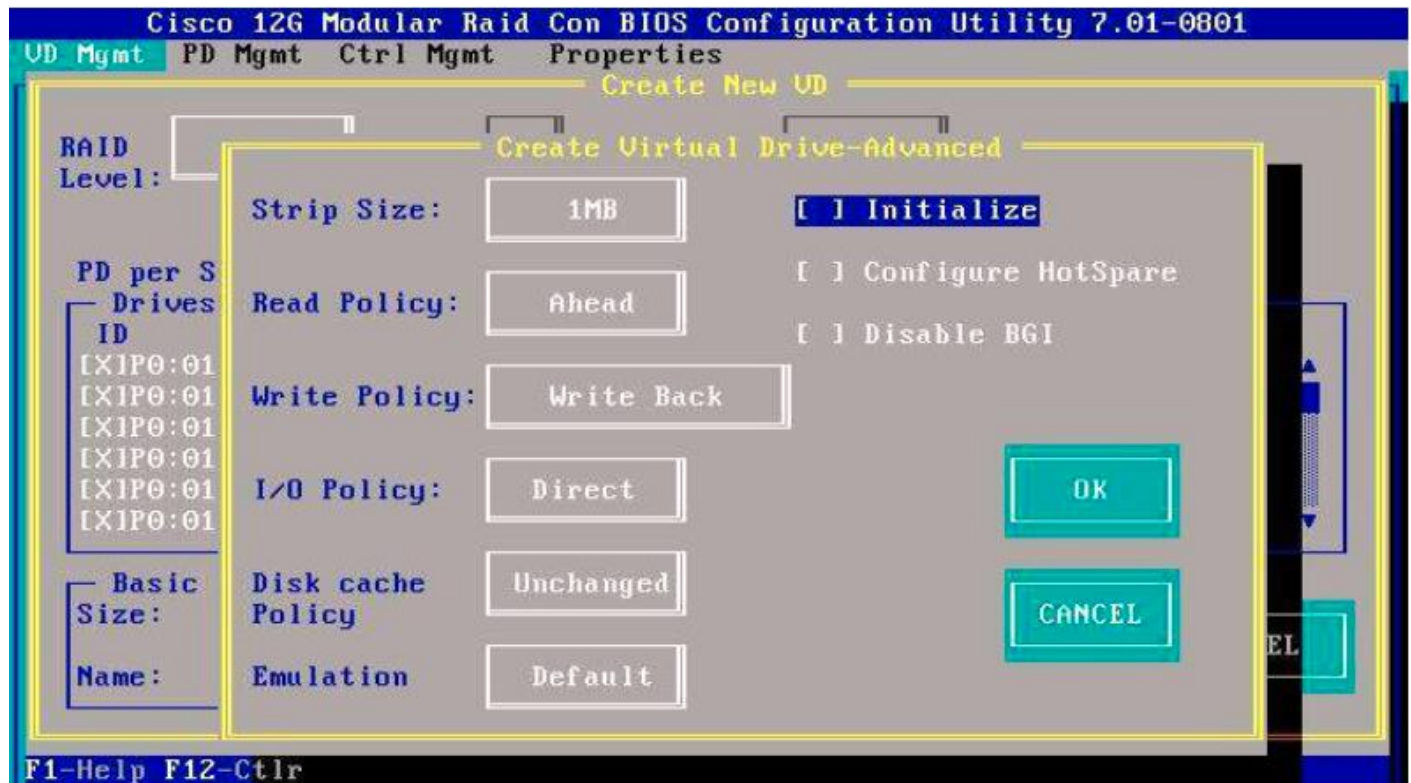

14. To create the second RAID 5 Virtual Drive press F2 for Operations and Select Create Virtual Drive.

15. Create a RAID 5 virtual drive with 6 disks:

- a. For RAID Level Choose RAID-5.
- b. Choose the next 6 disks.
- c. Give a Name for virtual drive 2.
- d. Choose Advanced option.
- e. For Strip Size choose 1MB.
- f. For Read Policy Choose Ahead.
- g. For Write Policy choose Write Back with BBU.
- h. For I/O Policy choose Direct.
- i. Keep the Default Disk cache Policy and Emulation.
- j. Choose Initialize.
- k. Click OK.

16. To create the third RAID 5 Virtual Drive press F2 for Operations and select Create Virtual Drive.

17. Create a RAID 5 virtual drive with 6 disks:

- a. For RAID Level Choose RAID-5.
- b. Choose the next 6 disks.
- c. Give a Name for virtual drive 3.
- d. Choose Advanced option.

- e. For Strip Size choose 1MB.
  - f. For Read Policy Choose Ahead.
  - g. For Write Policy choose Write Back with BBU.
  - h. For I/O Policy choose Direct.
  - i. Keep the Default Disk cache Policy and Emulation.
  - j. Choose Initialize.
  - k. Click OK.
18. To create the fourth RAID 5 Virtual Drive press F2 for Operations and select Create Virtual Drive.
19. Create a RAID 5 virtual drive with 6 disks:
- a. For RAID Level Choose RAID-5.
  - b. Choose the last 6 disks.
  - c. Give a Name for virtual drive 4.
  - d. Choose Advanced option.
  - e. For Strip Size choose 1MB.
  - f. For Read Policy Choose Ahead.
  - g. For Write Policy choose Write Back with BBU.
  - h. For I/O Policy choose Direct.
  - i. Keep the Default Disk cache Policy and Emulation.
  - j. Choose Initialize.
  - k. Click OK.
20. Press esc to exist MegaRAID Configuration Utility.

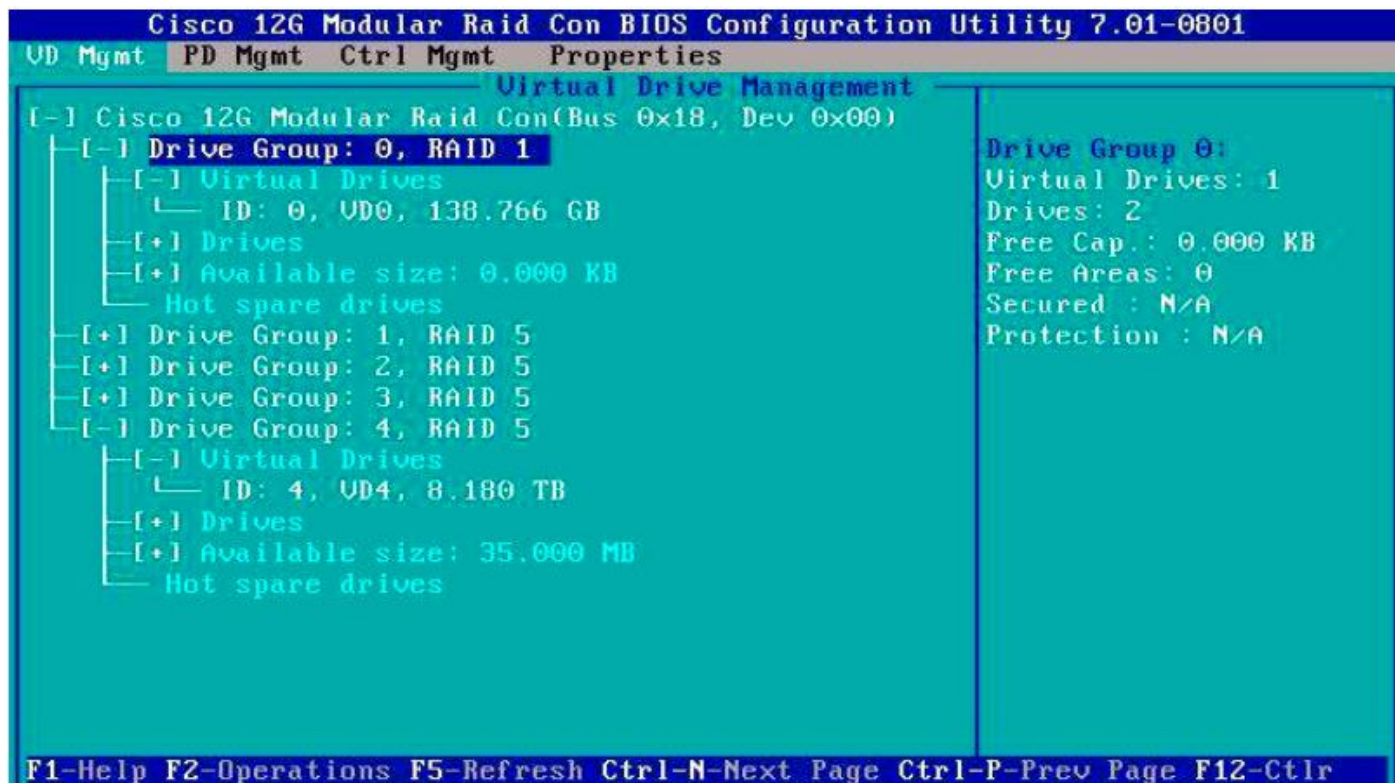

21. Press Ctrl+Alt+Del to reboot the server.
22. Repeat the steps 1-21 for each MapR Servers.

## MapR Server Operating System Installation

The following procedure show the SUSE Linux Enterprise Server 12 SP 2 Operation System installation on Internal Boot Drives.

1. In Cisco UCS Manager, click the Servers tab in the navigation pane.
2. Select Service Profile > root > Sub-Organization > HANA > MapR-01.
3. Click KVM Console.
4. When the KVM Console is launched, click Boot Server.
5. Click Virtual Media > Activate Virtual Devices:
  - a. Select the option Accept this Session for Unencrypted Virtual Media Session and then click Apply.
  - b. Click Virtual Media and Choose Map CD/DVD.
  - c. Click Browse to navigate ISO media location.
  - d. Click Map Device.
6. On the Initial screen select Installation to begin the installation process.
7. Choose Language, Keyboard layout, Select I Agree the License Terms and click Next.

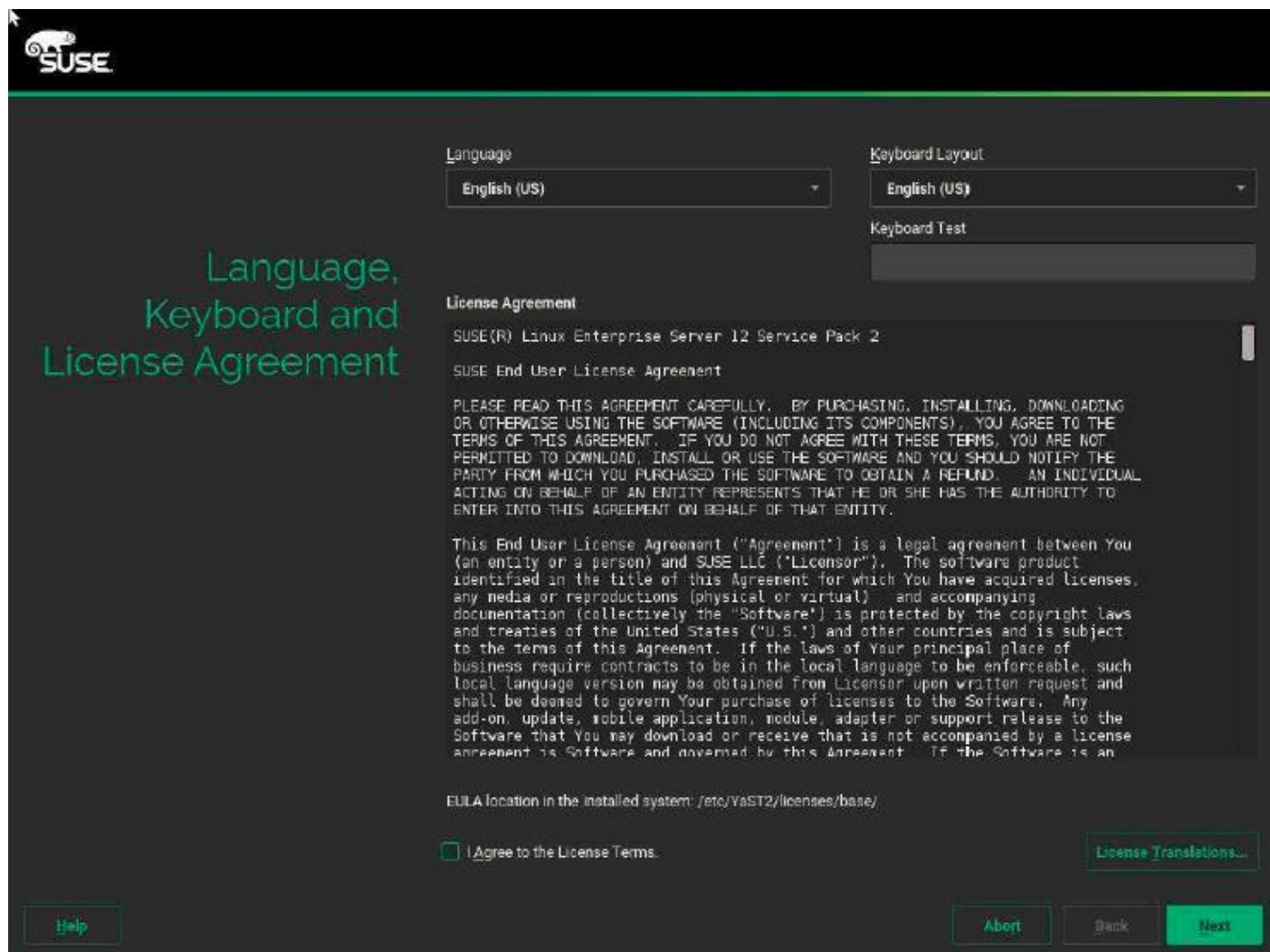

- On the Network Settings screen Under Overview click VNIC Ethernet NIC.

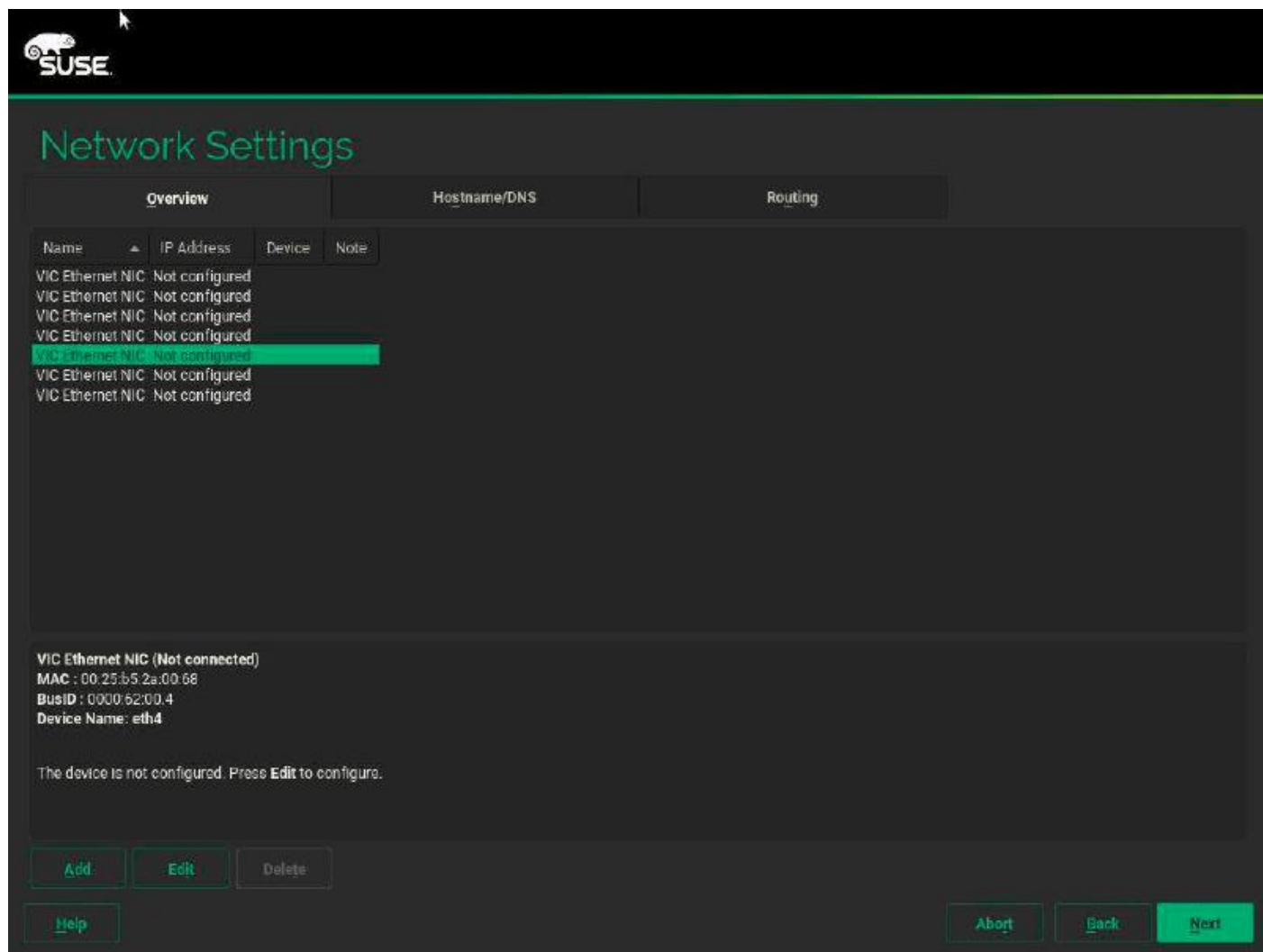

9. To configure the network interface on the OS, it is required to identify the mapping of the Ethernet device on the OS to vNIC interface on the Cisco UCS:
  - a. In Cisco UCS Manager, click the Servers tab in the navigation pane.
  - b. Expand Servers > Service Profile > root > Sub-Organization > HANA > MapR-01.
  - c. Click + to Expand.
  - d. Click vNICs.
  - e. On the right pane list of the vNICs with MAC Address are listed.

Name	MAC Address
vNIC MapR-01	00:25:B5:2A:00:2C
vNIC MapR-02	00:25:B5:2B:00:28
vNIC HANA-Storage	00:25:B5:2B:00:29
vNIC Mgmt	00:25:B5:2A:00:2E

- f. Note that the MAC Address of the Mgmt vNIC “00:25:B5:2A:00:2E”.
  - g. With the vNIC order in the Service Profile, vNIC for Management should be eth4.
10. By comparing MAC Address on the OS and Cisco UCS, eth4 on OS will carry the VLAN for Management.
11. Click Edit, under the Address tab
12. Click Statically Assigned IP Address:
- a. In the IP Address field enter <<Management IP address>>.
  - b. In the Subnet Mask field enter <<subnet mask for Management Interface>>.
  - c. In the Hostname field enter the hostname for Management Interface.

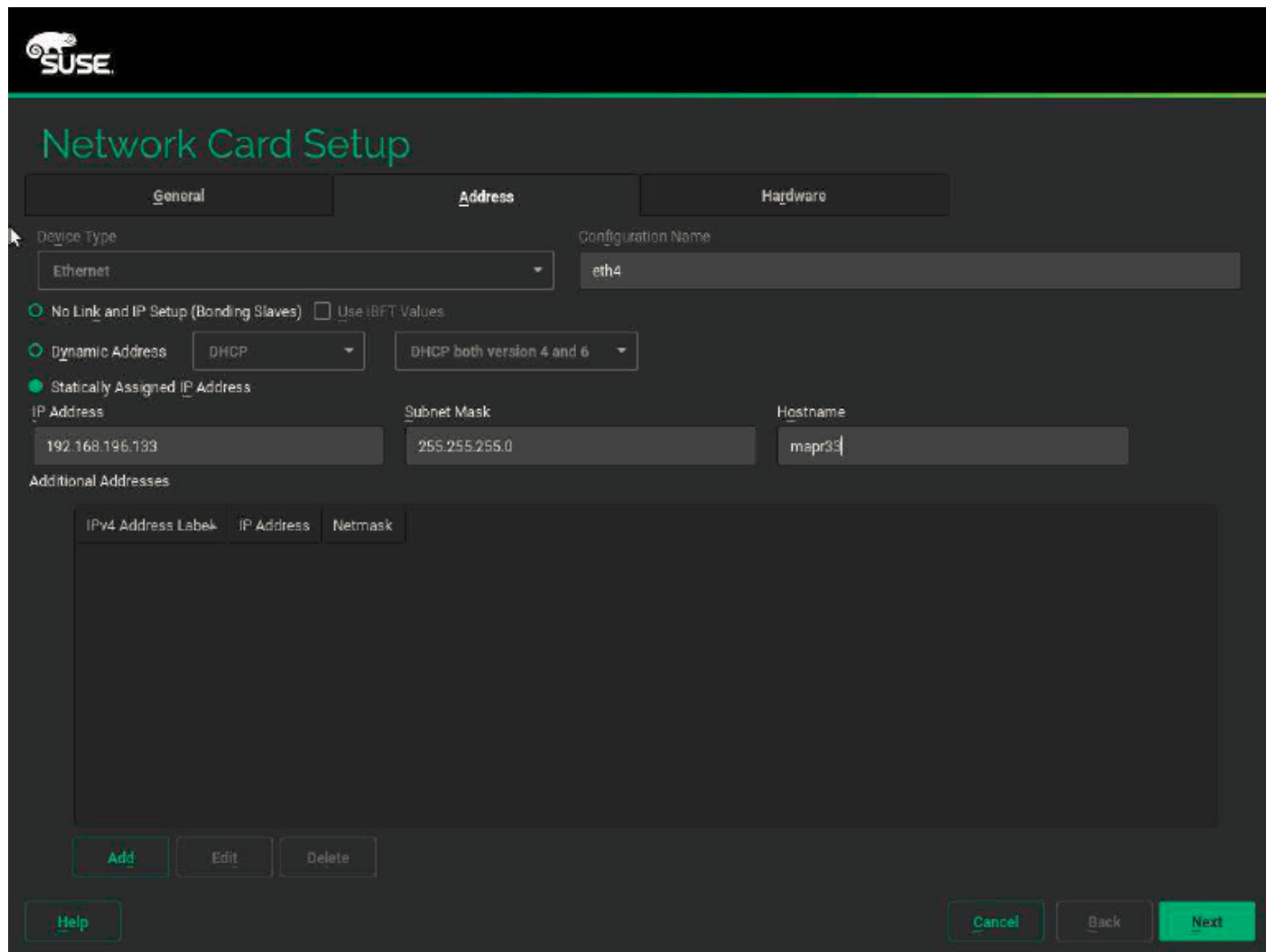

13. Repeat Steps 10-13 for each vNIC device.
14. On the Network Settings screen Select Hostname/DNS:
- a. In the Hostname field enter the Hostname.
  - b. In the Domain Name Field enter the Domain Name.
  - c. In the Name Server 1 field enter <<DNS server1>> and Name Server 2 field enter <<DNS server2>>.

- d. In the Search domains field enter <<domain1.com, domain2.com>>.
- e. Click Routing.

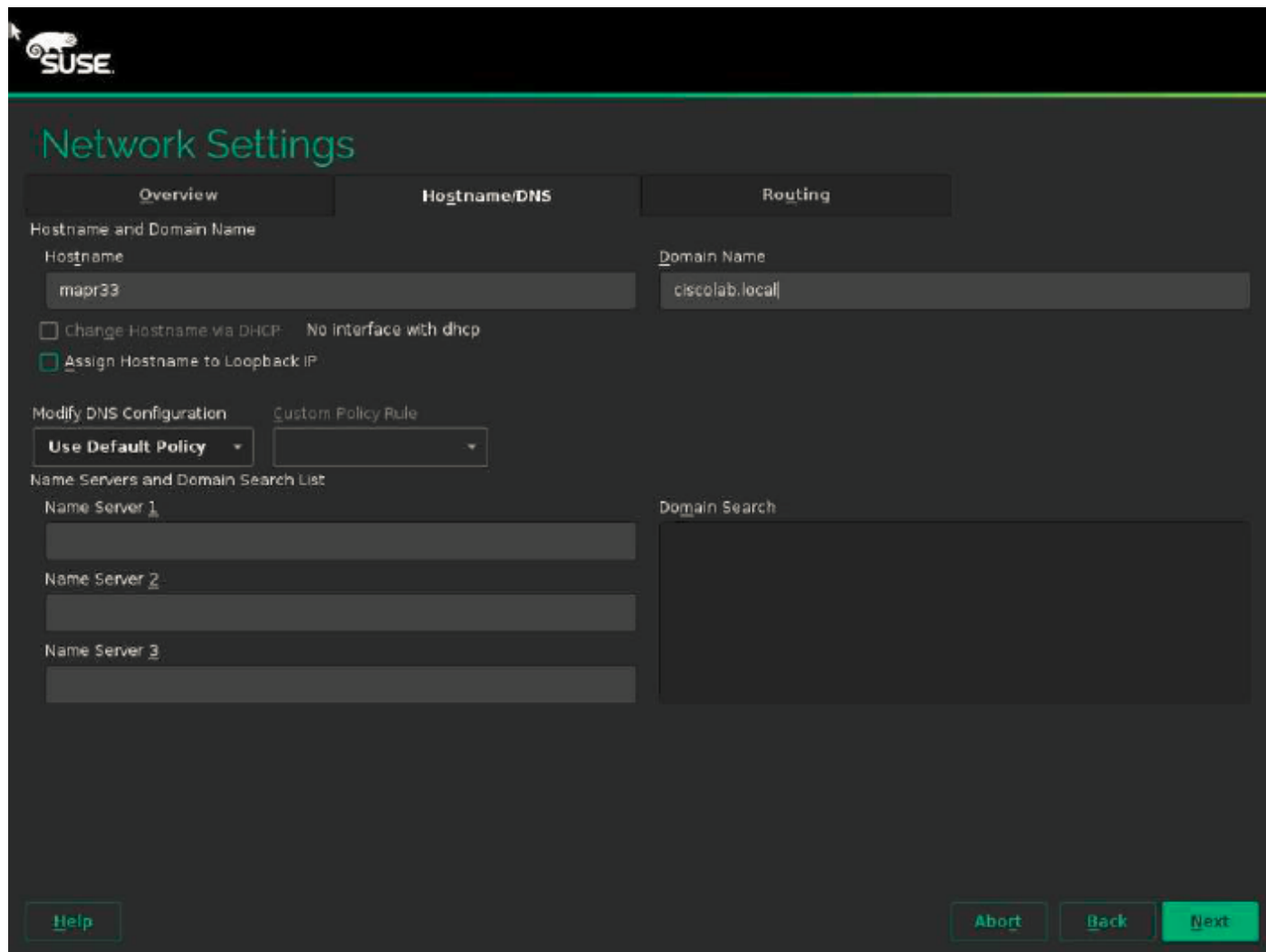

- f. For the Default IPv4 Gateway enter the <<Default Gateway>>.
- g. Click Next.



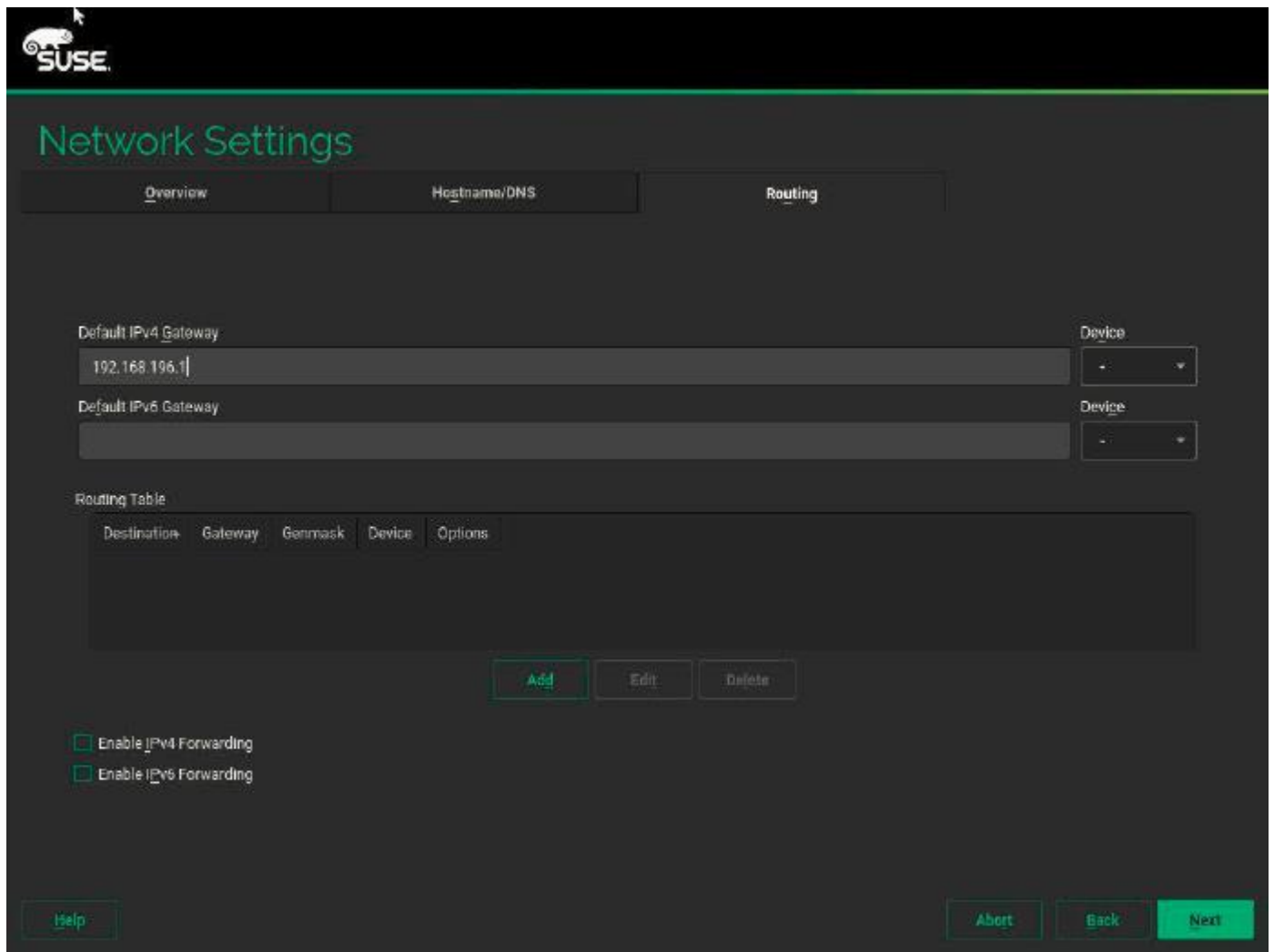

15. In the Registration screen and click Skip Registration. You will update the system in the following section.
16. In the Add On Product screen and click Next.
17. In the System Role leave Default System and click Next.



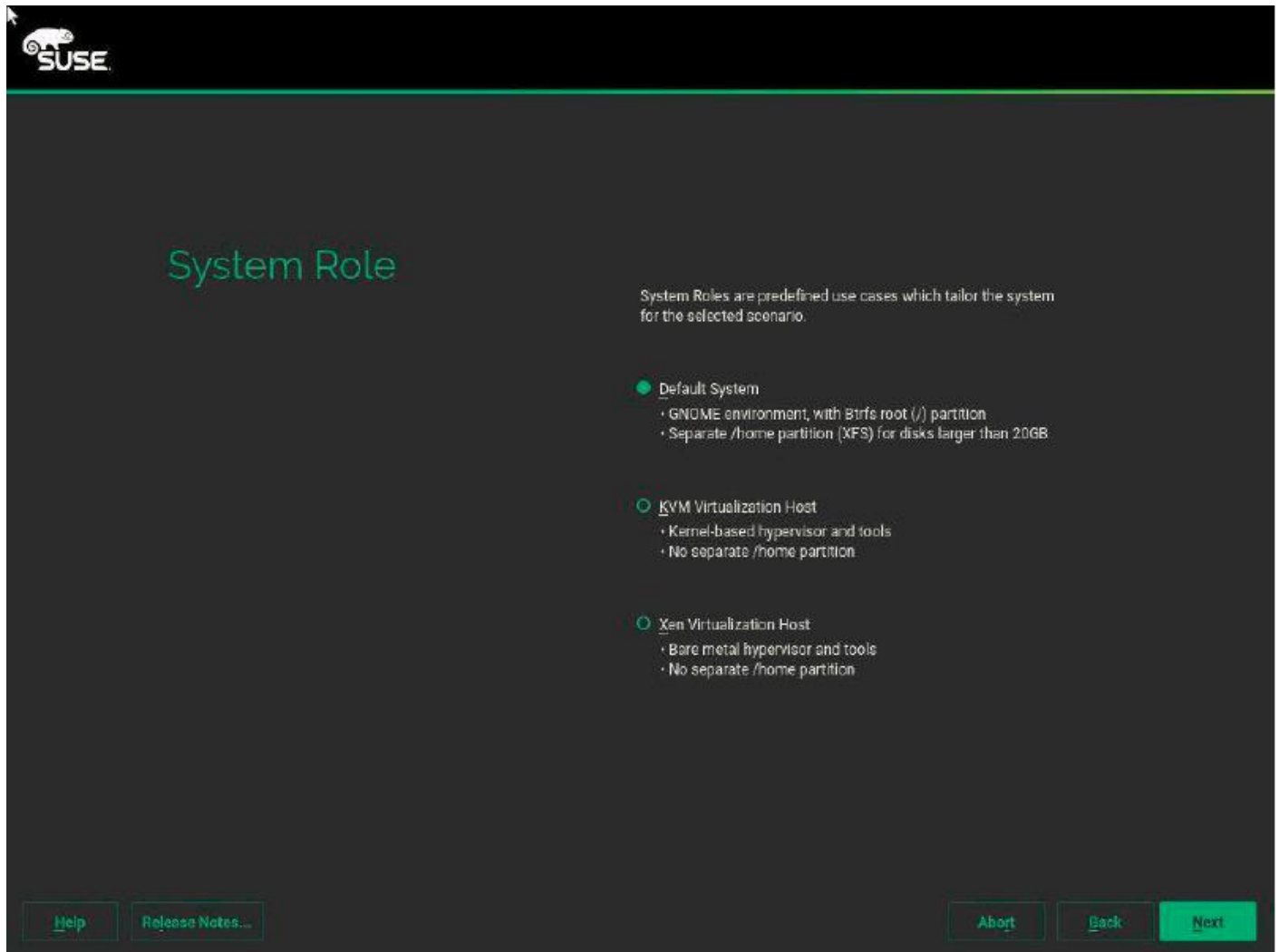

18. In the Suggested Partitioning screen click Expert Partitioner.

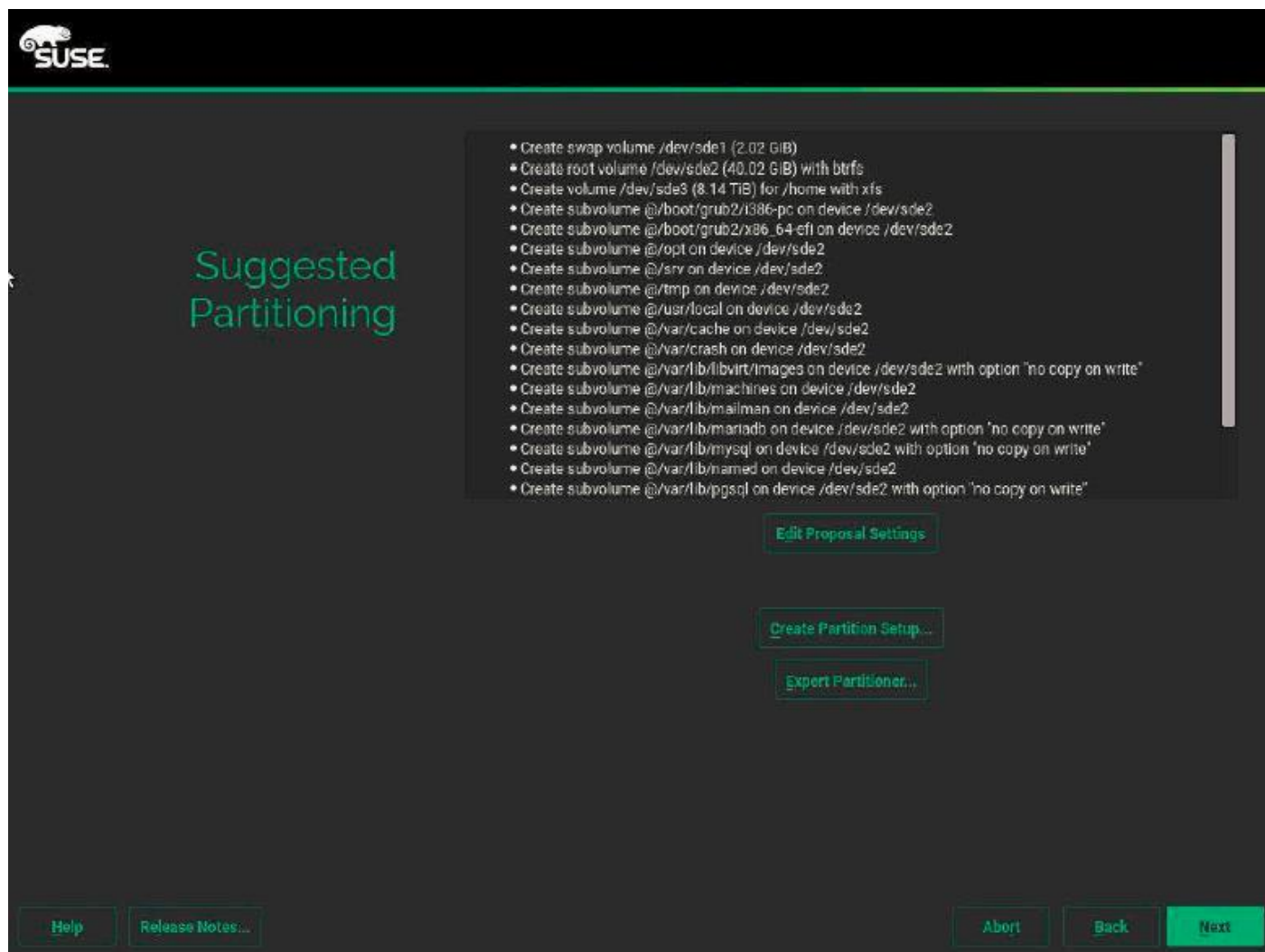

19. In the Expert Partitioner screen, delete the system created Partition.

20. Select the first Virtual Drive for Operating System and click Add.

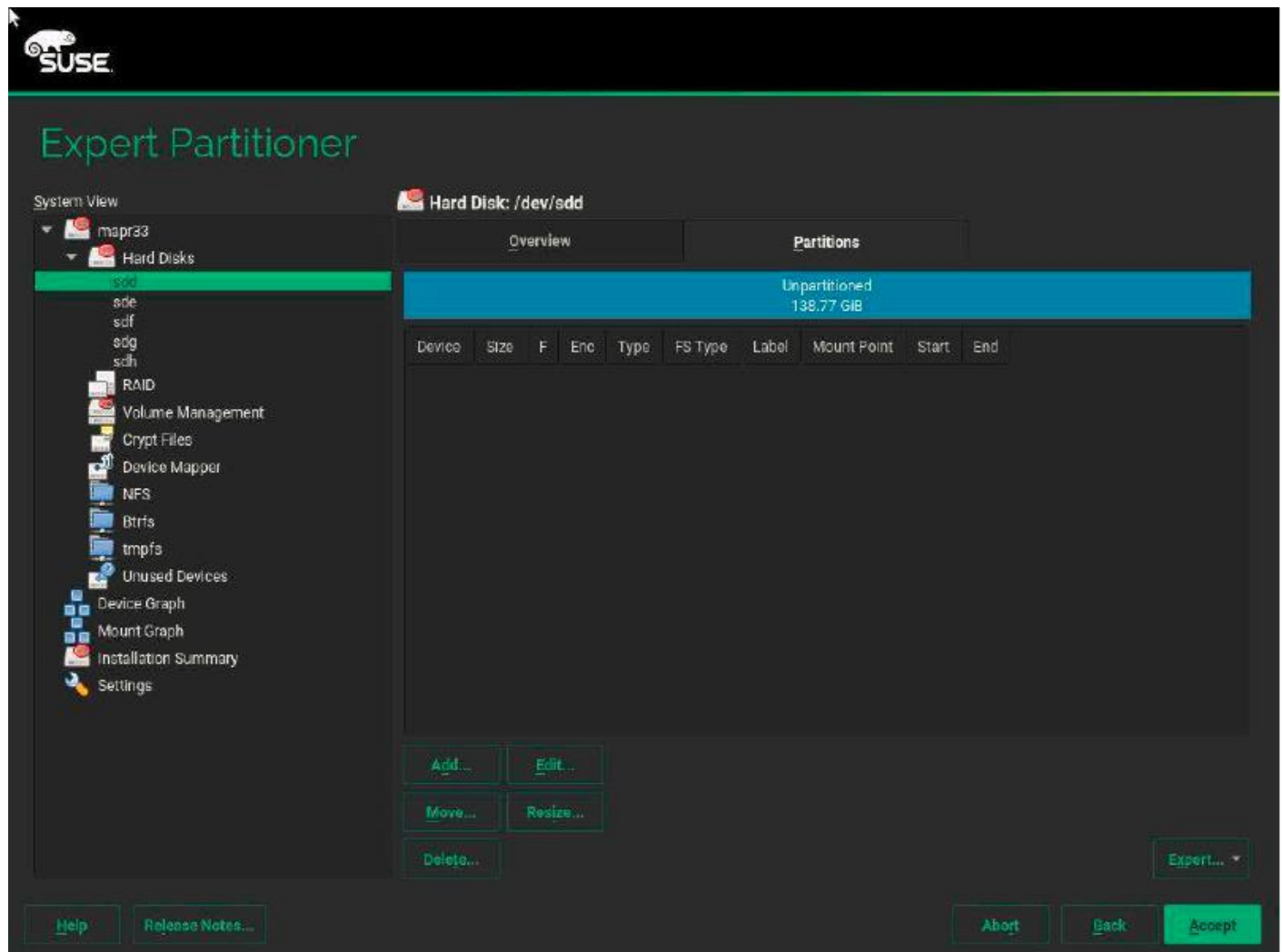

21. In the Add Partition on /dev/sdd, select Primary Partition and click Next.
22. For the New Partition Size, select Custom Size.
23. In the Size field enter 200 MB and click Next.

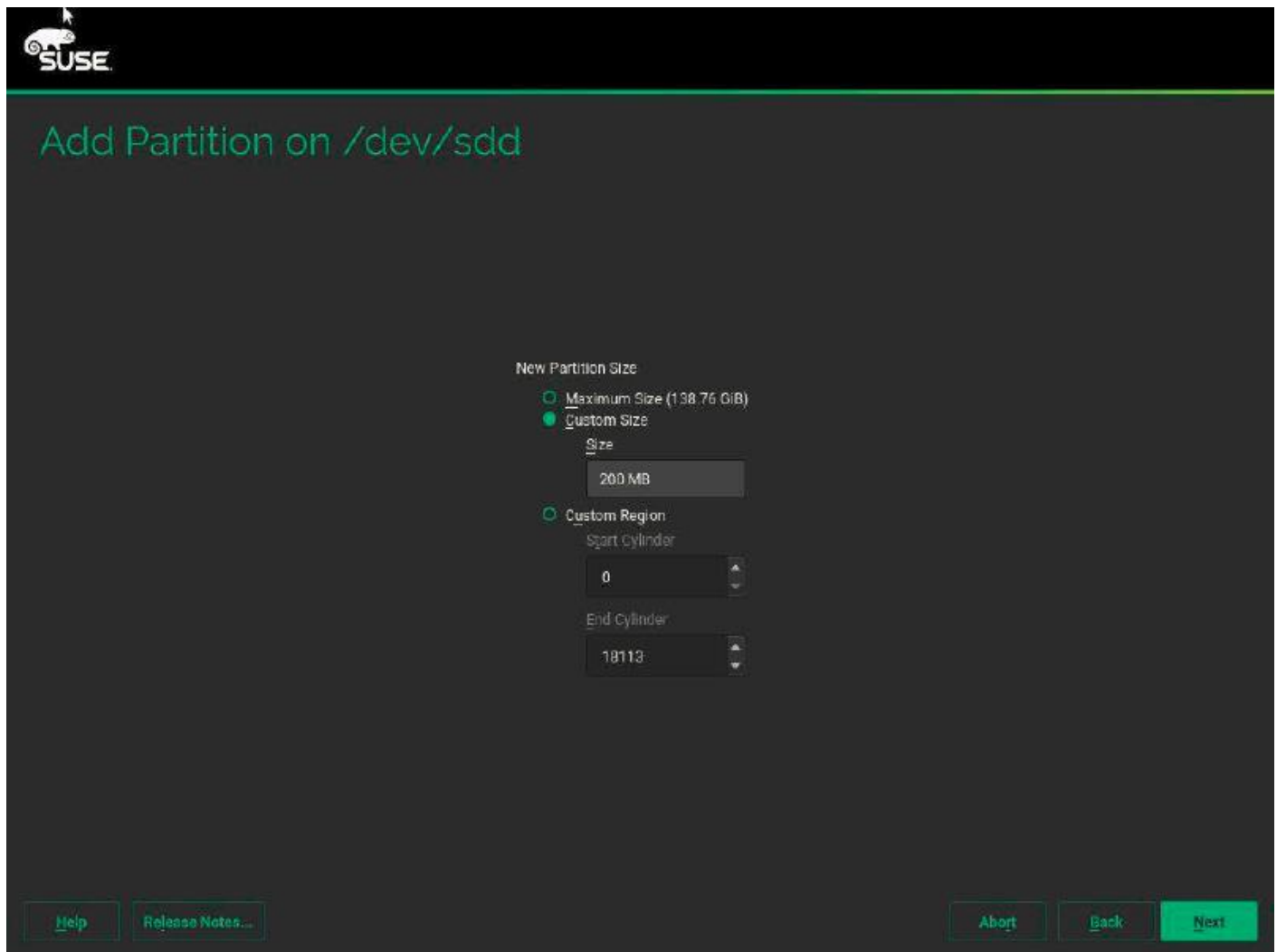

24. For the Role Keep Operating System and click Next.
25. For Formatting Options -> Format Partition -> File System select ext3.
26. For Mounting Options -> Mount Partition -> Mount Point select /boot.
27. Click Finish.

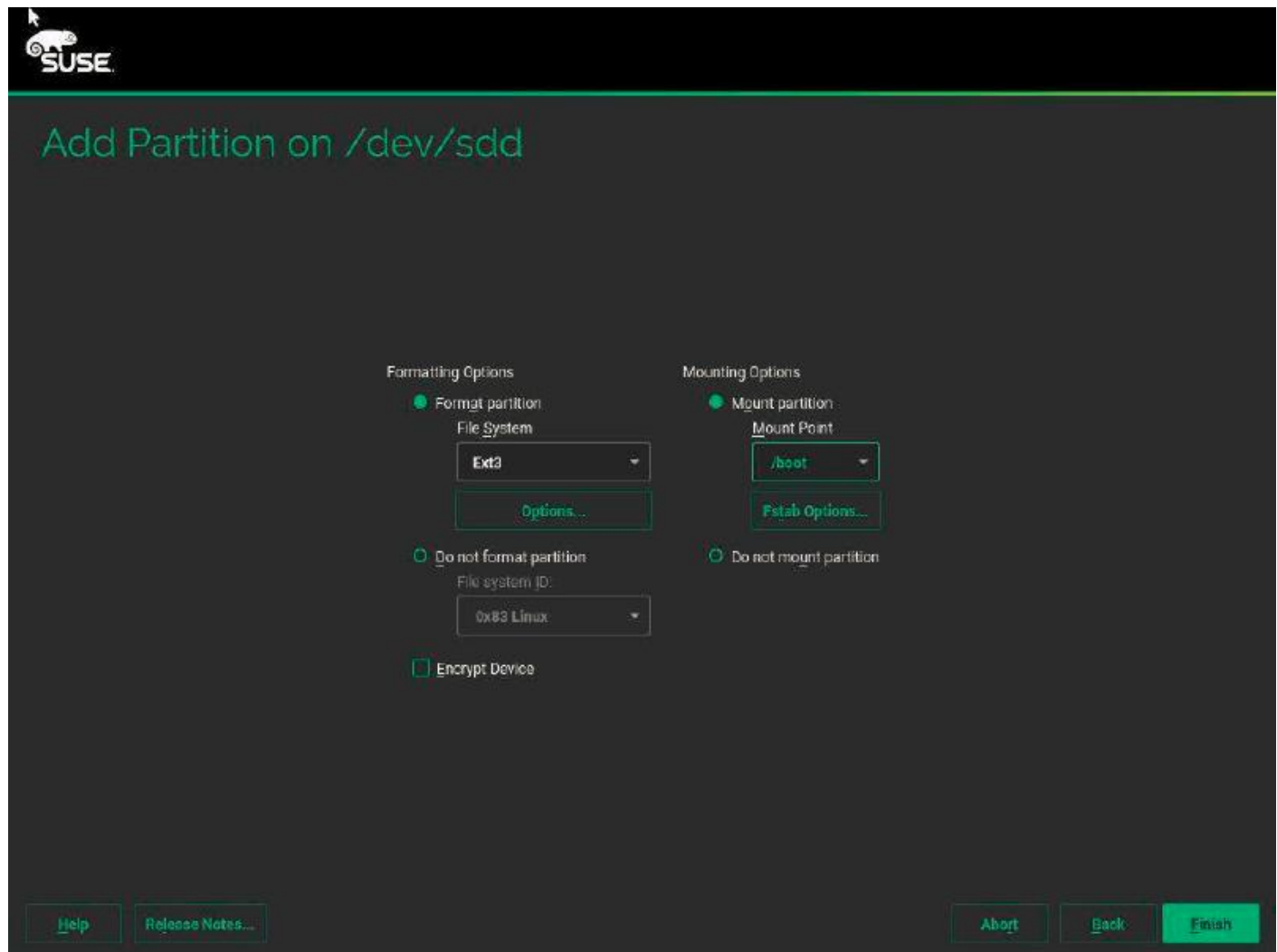

28. In the Add Partition on /dev/sdd, select Primary Partition and click Next.
29. For the New Partition Size, select Custom Size.
30. In the Size field enter 2 GB and click Next.
31. For the Role Keep select Swap and click Next.
32. For Formatting Options -> Format Partition -> File System select Swap.
33. For Mounting Options -> Mount Partition -> Mount Point select swap.
34. Click Finish.

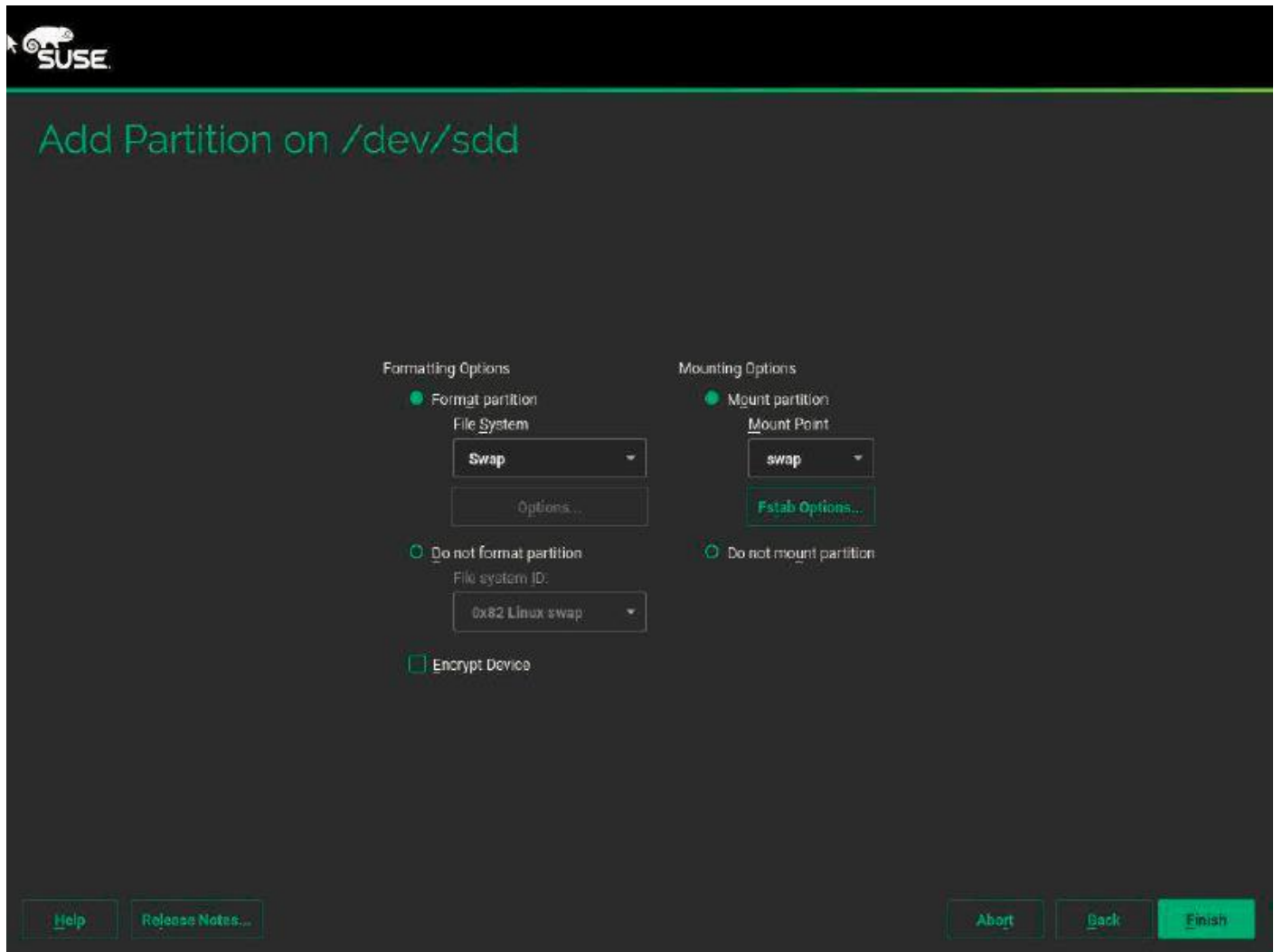

35. In the Add Partition on /dev/sdd, select Primary Partition and click Next.
36. For the New Partition Size, select Custom Size.
37. In the Size field enter 100 GB and click Next.
38. For the Role Keep Operating System and click Next.
39. For Formatting Options -> Format Partition -> File System select ext3.
40. For Mounting Options -> Mount Partition -> Mount Point select /
41. Click Finish.

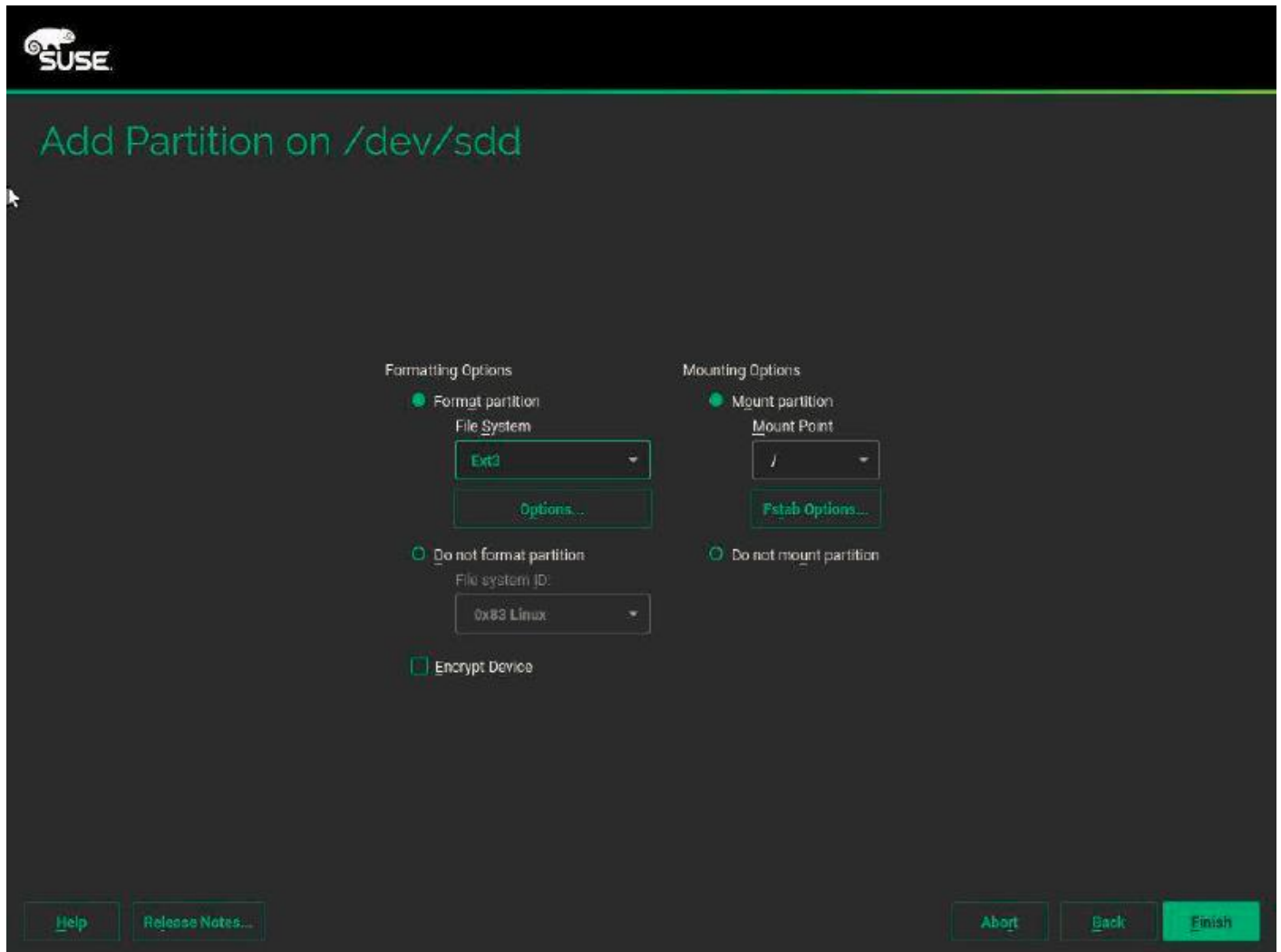

42. On the Expert Partitioner screen press Accept.

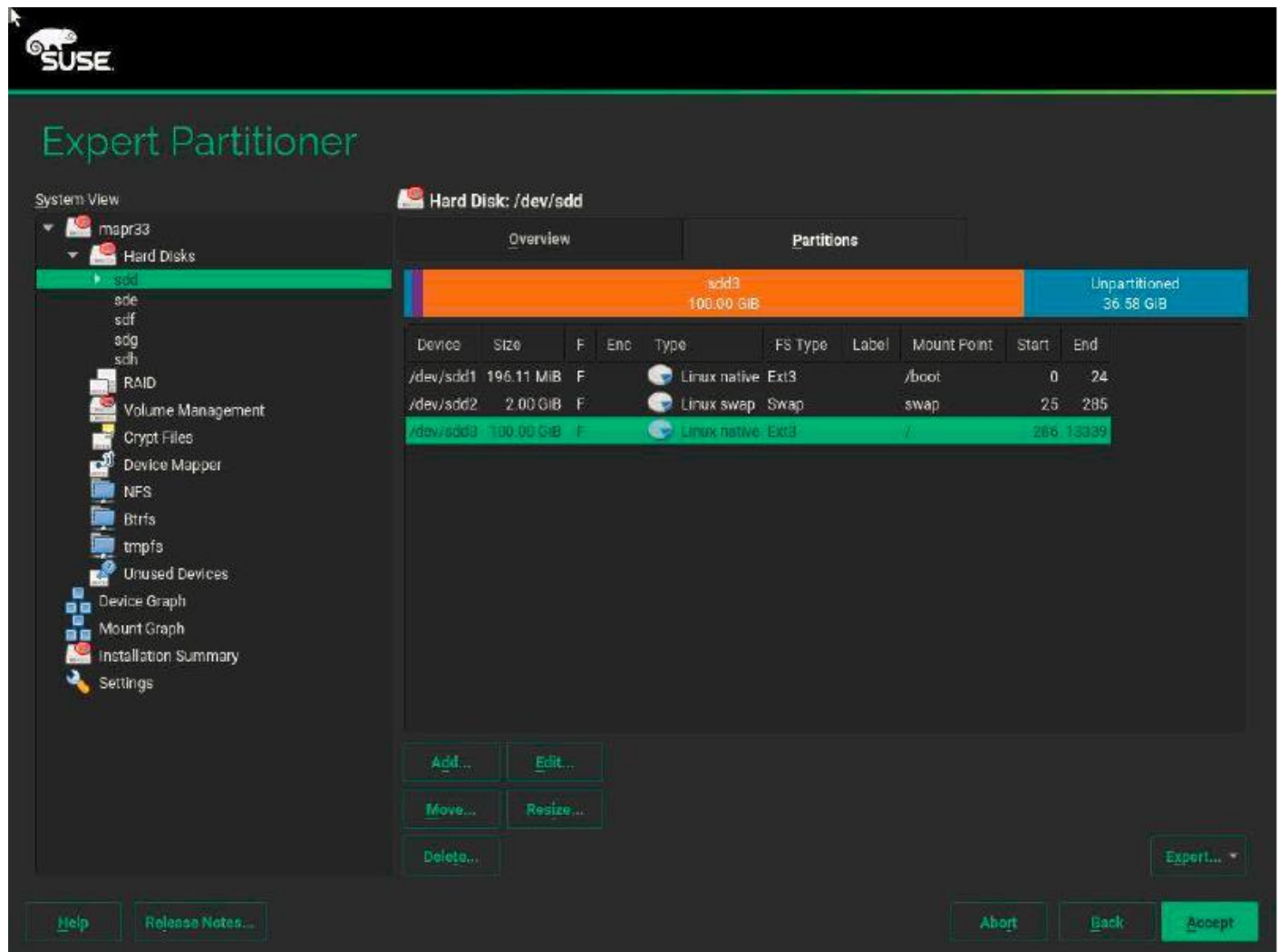

43. In the Suggested Partitioning click Next.

44. Select the appropriate Time Zone and click Next.



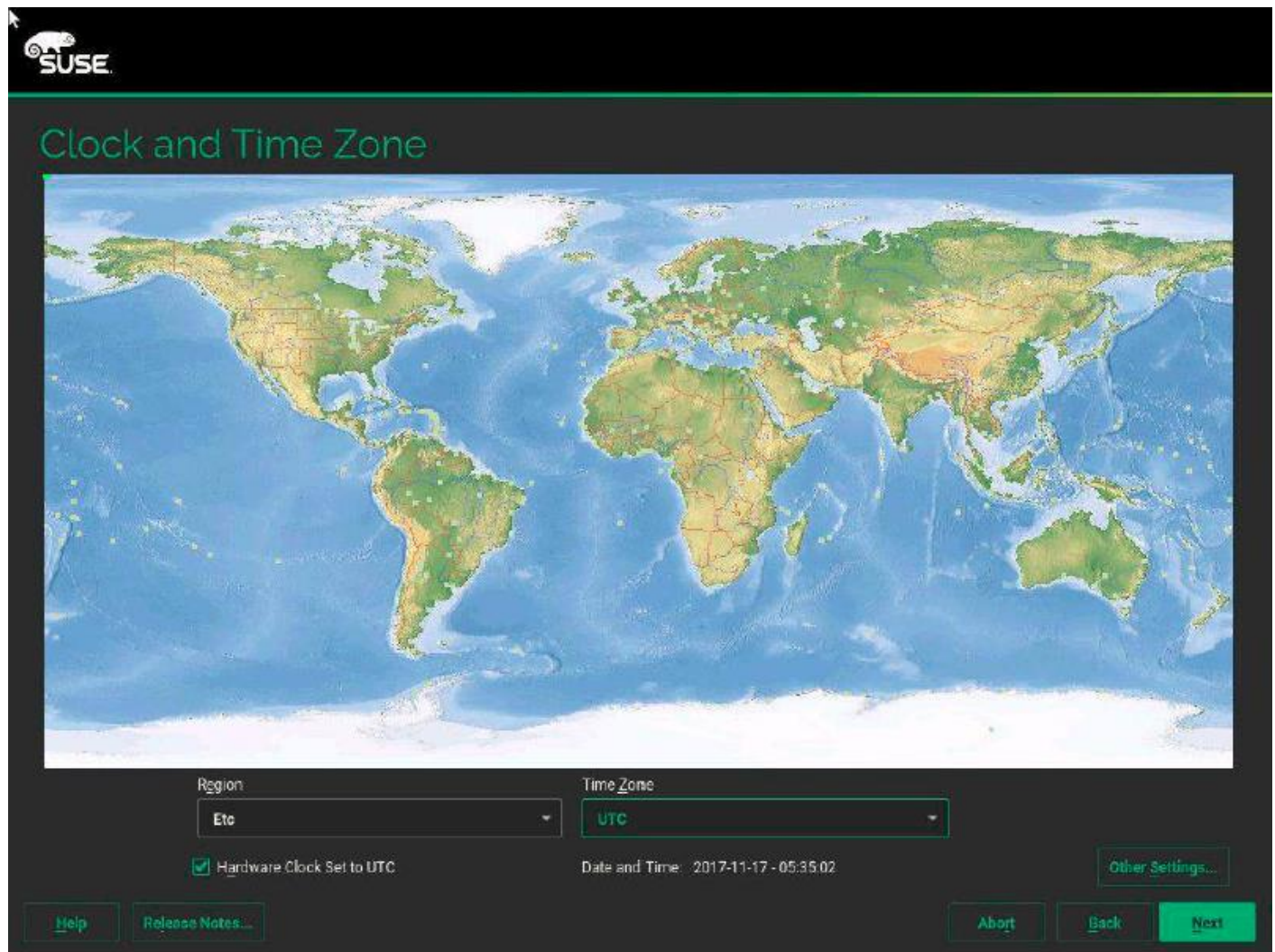

45. In the Create New User screen, select skip User Creation and click Next. You will create a user for mapr in the following screen.
46. Enter the Password for root User and Confirm Password.
47. In the Installation Settings, Under Firewall and SSH click Firewall will be enabled (disable) to disable Firewall.
48. In the Installation Settings screen click Kdump.

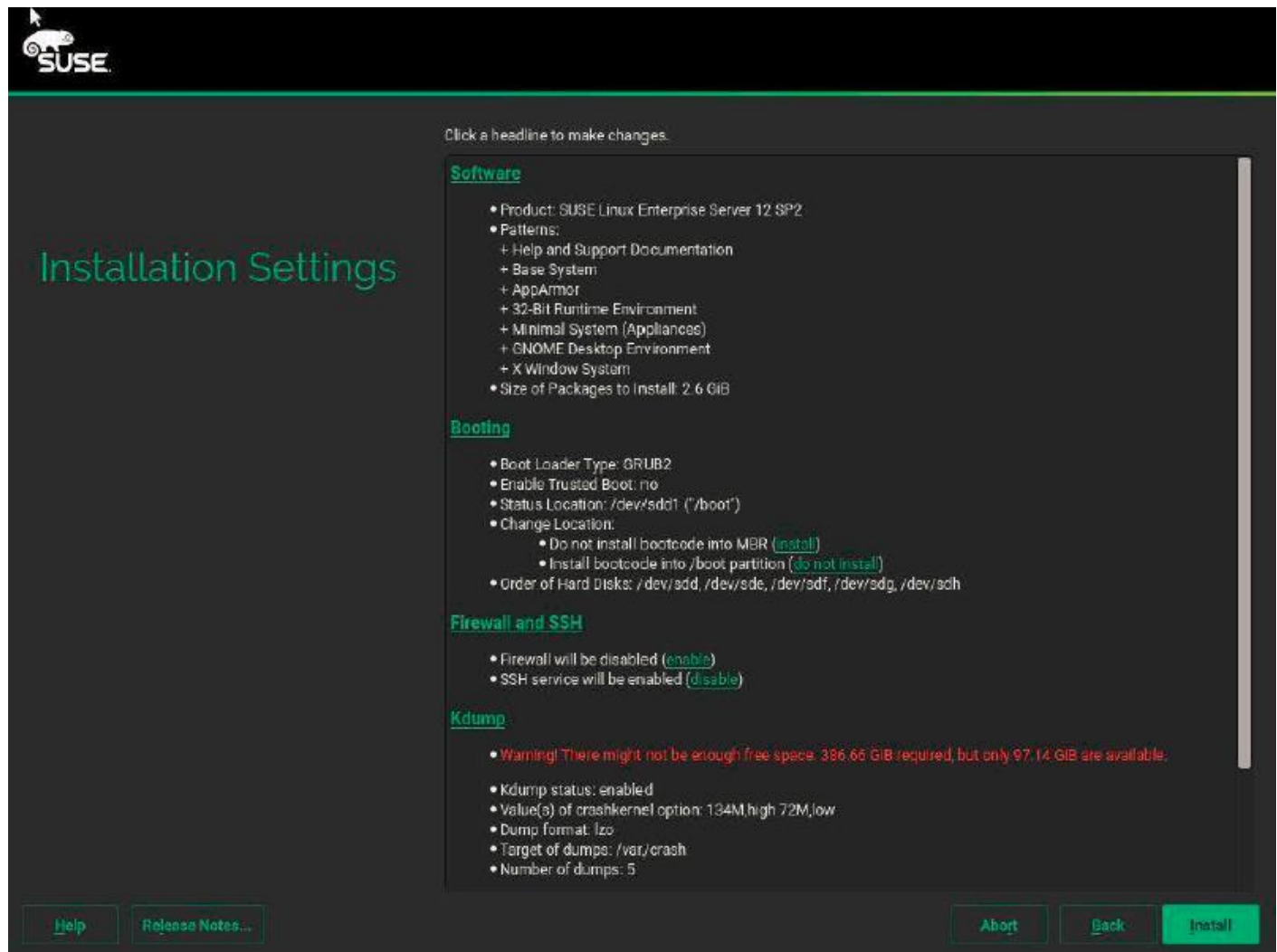

49. Select Disable Kdump and click OK.

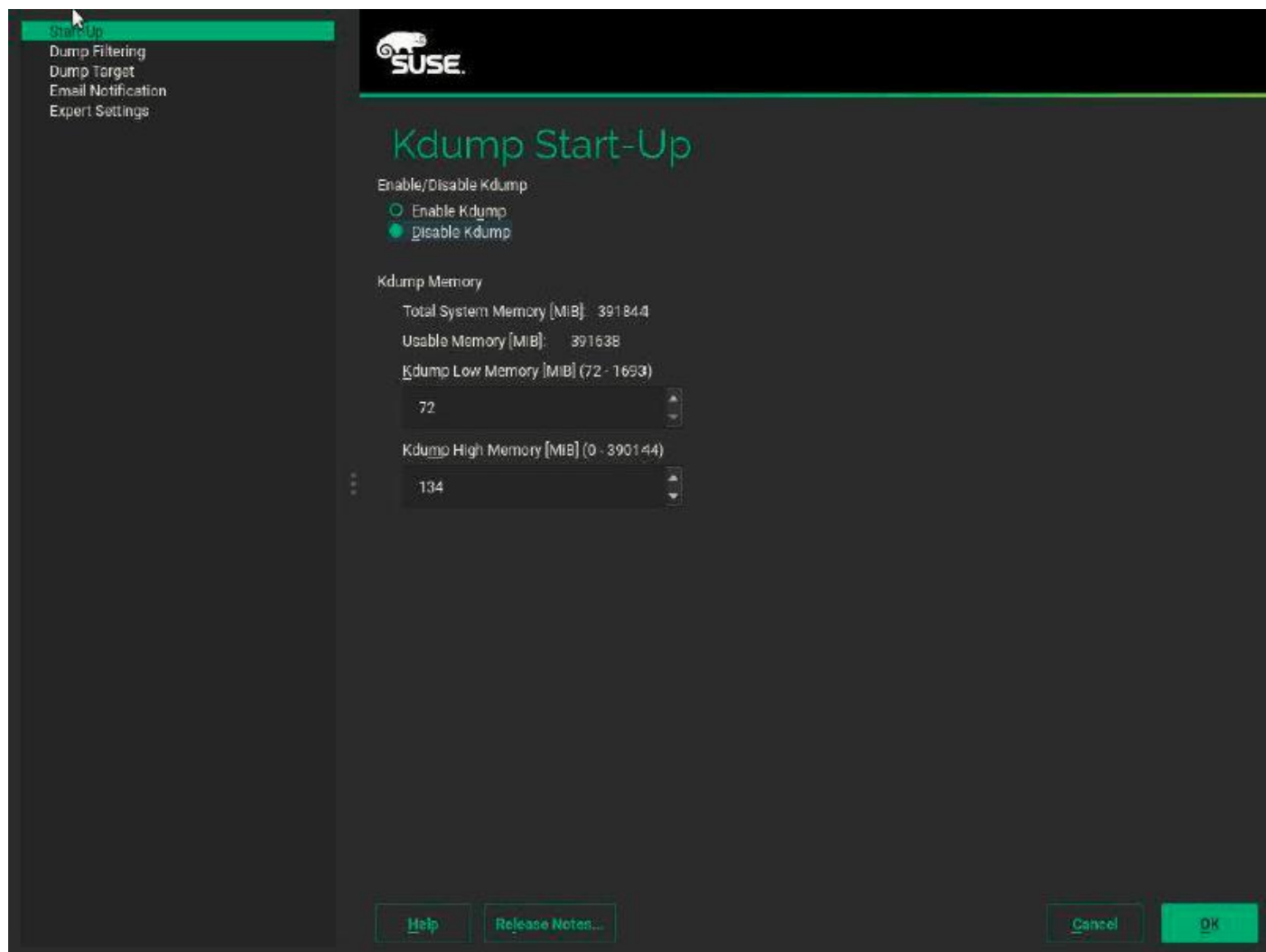

50. In the Installation Settings screen click Default Systemd Target.
51. Select Text mode for Available Targets and click OK.
52. In the Installation Settings screen click Install.

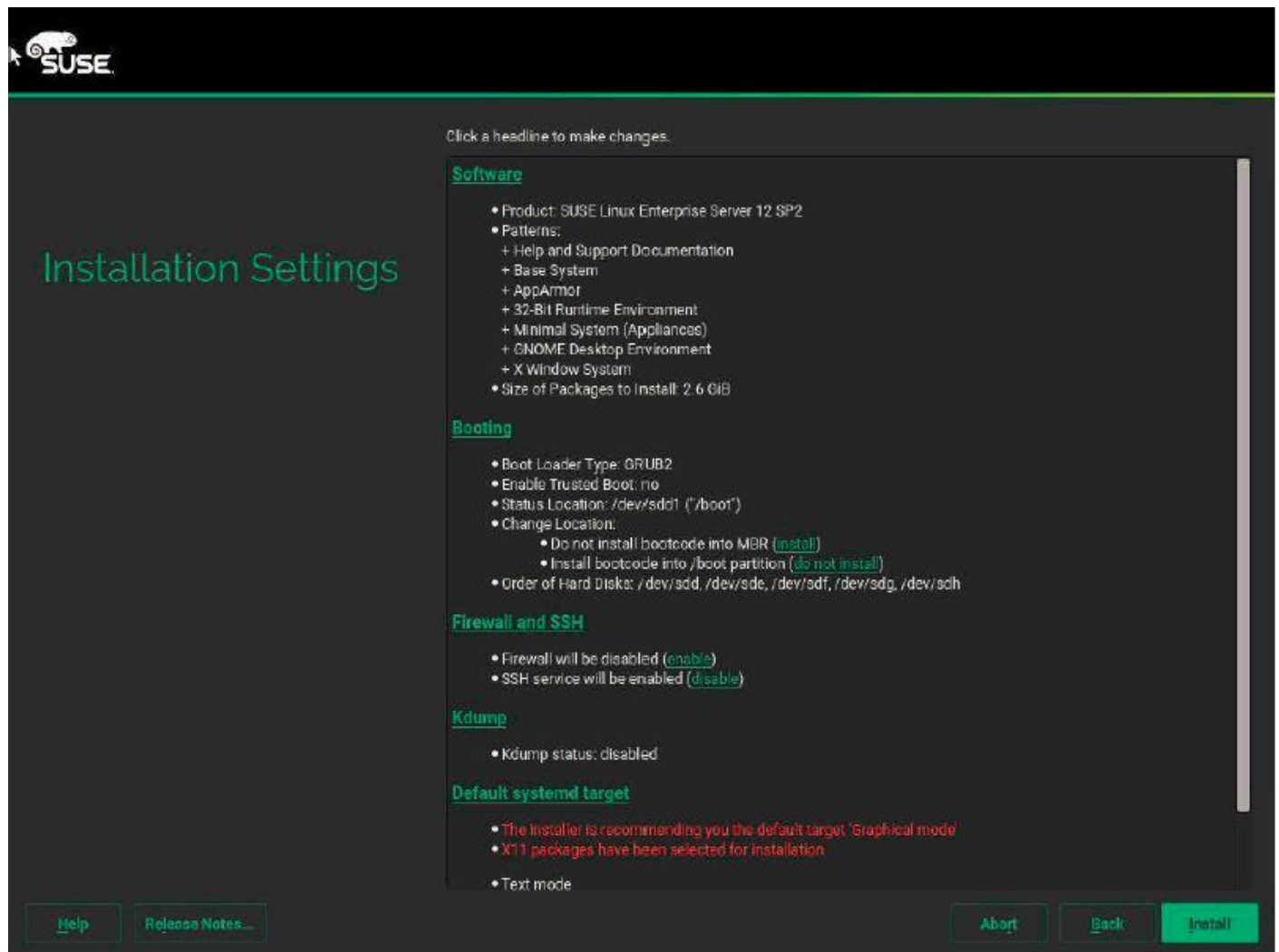

53. In the Confirm Installation screen, click Install.

The Install process begins.

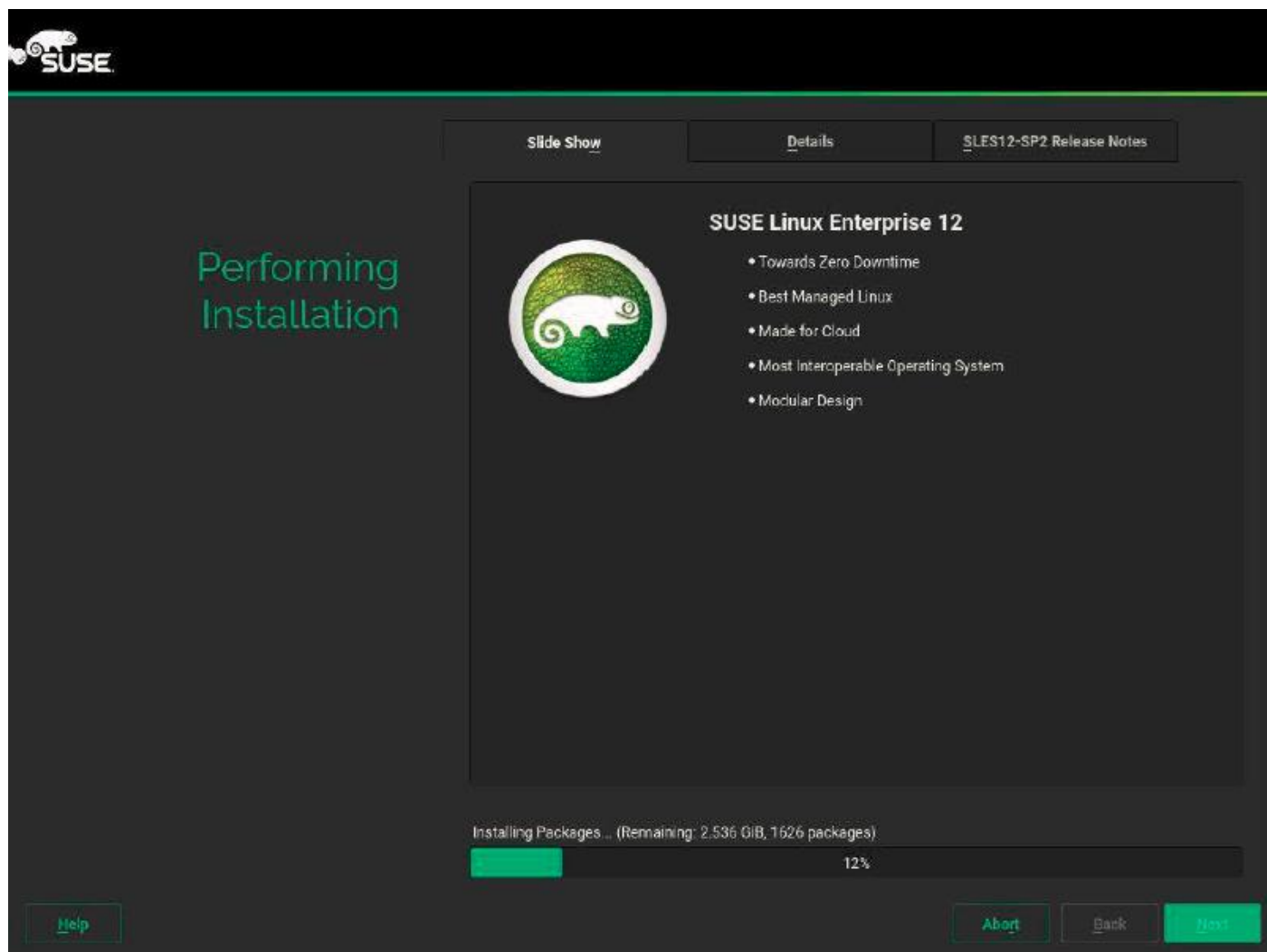

54. The Install process will complete and boot the system.

55. Follow the steps above to install SUSE Linux Enterprise Server 12 SP 2 on all the MapR servers.

## Operating System Network Configuration

To customize the server in preparation for the MapR Installation, complete the following steps:

### Hostnames



The operating system must be configured in such a way that the short name of the server is displayed for the command 'hostname' and Full Qualified Host Name is displayed with the command 'hostname -d'.

1. ssh to the Server using Management IP address assigned to the server during installation.
2. Login as root and password.
3. Edit the Hostname:

```
vi /etc/HOSTNAME
<<hostname>>.<<Domain Name>>
```

## IP Address

Each MapR Server is configured with 4 vNIC device. Table 11 lists the IP Address information required to configure the IP address on the Operating System. IP Address and Subnet Mask provided below are example only, please configure IP address as per your environment.

**Table 11** List the IP Address for SAP HANA Server

vNIC Name	VLAN ID	IP Address Range	Subnet Mask
MapR-01	<<var_mapr-01_vlan_id>>	10.21.21.101 to 10.21.21.104	255.255.255.0
MapR-02	<<var_mapr-02_vlan_id>>	10.22.22.101 to 10.22.22.104	255.255.255.0
HANA-Storage	<<var_storage_vlan_id>>	192.168.110.101 to 192.168.110.104	255.255.255.0
Management	<<var_mgmt_vlan_id>>	192.168.196.101 to 192.168.196.104	255.255.0.0

- To configure the network interface on the OS, it is required to identify the mapping of the ethernet device on the OS to vNIC interface on the Cisco UCS.
- From the OS, execute the following command to get list of Ethernet device with MAC Address:

```
ifconfig -a|grep HWaddr
eth0 Link encap:Ethernet HWaddr 00:25:B5:2A:00:2C
eth1 Link encap:Ethernet HWaddr 00:25:B5:2B:00:28
eth2 Link encap:Ethernet HWaddr 00:25:B5:2B:00:29
eth3 Link encap:Ethernet HWaddr 00:25:B5:2A:00:2E
```

- In Cisco UCS Manager, click the Servers tab in the navigation pane.
- Expand Servers > Service Profile > root > Sub-Organization > HANA > MapR-01.
- Click + to Expand. Click vNICs.
- On the right pane list of the vNICs with MAC Address are listed.

Name	MAC Address	Desired Or... ▲	Actual Order	Fabric ID
vNIC MapR-01	00:25:B5:2A:00:2C	1	1	A B
vNIC MapR-02	00:25:B5:2B:00:28	2	2	B A
vNIC HANA-Storage	00:25:B5:2B:00:29	3	3	B A
vNIC Mgmt	00:25:B5:2A:00:2E	4	4	A B

- Note the MAC Address of the MapR-01 vNIC is "00:25:B5:2A:00:2C".
- By comparing the MAC Address on the OS and Cisco UCS, eth0 on OS will carry the VLAN for MapR-01.
- Go to the network configuration directory and create a configuration for eth0:

```
/etc/sysconfig/network/
```

```

vi ifcfg-eth0
##
# MapR-01 Network
##
BOOTPROTO='static'
BROADCAST=''
ETHTOOL_OPTIONS=''
IPADDR='<<IP address for MapR-01 example:10.21.21.101/24>>'
MTU='9000'
NAME='VIC Ethernet NIC'
NETWORK=''
REMOTE_IPADDR=''
STARTMODE='auto'

```

10. Repeat the steps 1 to 12 for each vNIC interface.

11. Add default gateway:

```

vi etc/sysconfig/network/routes
default 192.168.196.1 - -

```

## DNS

Domain Name Service configuration must be done based on the local requirements.

### Configuration Example

Add DNS IP if it is required to access internet:

```

vi /etc/resolv.conf
nameserver <<IP of DNS Server1>>
nameserver <<IP of DNS Server2>>
search <<Domain_name>>
Hosts

```

All nodes should be able to resolve internal network IP address, below is an example of 4 node host file with the entire network defined in the /etc/hosts file.

Example:

```

127.0.0.1 localhost
# special IPv6 addresses
::1 localhost ipv6-localhost ipv6-loopback
#
## MapR 01
#
10.21.221.131 mapr31.ciscolab.local mapr31
10.21.221.132 mapr32.ciscolab.local mapr32
10.21.221.133 mapr33.ciscolab.local mapr33
10.21.221.134 mapr34.ciscolab.local mapr34
#
## MapR 02
#
10.22.222.131 mapr31b.ciscolab.local mapr31b
10.22.222.132 mapr32b.ciscolab.local mapr32b
10.22.222.133 mapr33b.ciscolab.local mapr33b
10.22.222.134 mapr34b.ciscolab.local mapr34b
#
## HANA Storage Network
#
192.168.110.211 cishanaso11s.ciscolab.local cishanaso11s
192.168.110.212 cishanaso12s.ciscolab.local cishanaso12s
192.168.110.213 cishanaso13s.ciscolab.local cishanaso13s
192.168.110.214 cishanaso14s.ciscolab.local cishanaso14s
192.168.110.215 cishanaso15s.ciscolab.local cishanaso15s
192.168.110.216 cishanaso16s.ciscolab.local cishanaso16s
192.168.110.217 cishanaso17s.ciscolab.local cishanaso17s
192.168.110.218 cishanaso18s.ciscolab.local cishanaso18s

```



```

#
## MapR Storage
#
192.168.110.131 mapr31s.ciscolab.local mapr31s
192.168.110.132 mapr32s.ciscolab.local mapr32s
192.168.110.133 mapr33s.ciscolab.local mapr33s
192.168.110.134 mapr34s.ciscolab.local mapr34s
#
## MapR Storage Virtual IP
#
192.168.110.71 maprvip31
192.168.110.72 maprvip32
192.168.110.73 maprvip33
192.168.110.74 maprvip34
192.168.110.75 maprvip35
192.168.110.76 maprvip36
192.168.110.77 maprvip37
192.168.110.78 maprvip38
#
## Management
192.168.196.131 mapr31m.ciscolab.local mapr31m
192.168.196.132 mapr32m.ciscolab.local mapr32m
192.168.196.133 mapr33m.ciscolab.local mapr33m
192.168.196.134 mapr34m.ciscolab.local mapr34m

```

## SUSE Linux Enterprise Server 12 System Update and OS Customization for MapR Servers

To updated and customize the SLES 12 SP 2 System for MapR Servers, complete the following steps:

1. Register SUSE Linux Enterprise installations with the SUSE Customer Center:

```
SUSEConnect -r <<Registration Code>> -e <<email address>>
```

2. Execute the following command to update the SLES 12 SP 2 to latest patch level:

```
zypper update
```

3. Follow the on screen instruction to complete the update process.
4. Install additional packages:

```
zypper install tuned rpcbind java-1_8_0-openjdk java-1_8_0-openjdk-headless java-1_8_0-openjdk-devel ipmitool
```

5. Disable transparent hugepages. Modify /etc/default/grub search for the line starting with "GRUB\_CMDLINE\_LINUX\_DEFAULT" and append to this line:

```
transparent_hugepage=never
```

6. Save your changes and run:

```
grub2-mkconfig -o /boot/grub2/grub.cfg
```



After a reboot, THP will be disabled.

7. Add mapr user and group. Make sure that <uid> and <gid> are greater than 1000 and the same on all MapR cluster nodes. The mapr defaults of 2000 for both uid and gid will ensure consistency with other default MapR clusters for inter-cluster mirroring:

```
groupadd mapr -g <gid>
useradd mapr -u <uid> -g <gid>
```



## 8. Activate rpcbind:

```
service rpcbind start
chkconfig rpcbind on
```

## 9. Append following parameters in /etc/sysctl.conf:

```
sunrpc.tcp_slot_table_entries = 128
sunrpc.tcp_max_slot_table_entries = 128
net.ipv4.tcp_slow_start_after_idle = 0
```

## 10. Add the following line into /etc/modprobe.d/sunrpc-local.conf. Create the file, if it does not exist:

```
options sunrpc tcp_slot_table_entries=128
options sunrpc tcp_max_slot_table_entries=128
```

## 11. Activate tuned:

```
service tuned start
chkconfig tuned on
```

## 12. Enable tuned profile:

```
tuned-adm profile throughput-performance
```

## 13. Reboot the OS by issuing reboot command

## Install Cisco eNIC Driver

To download the Cisco UCS Drivers ISO bundle, which contains most of the Cisco UCS Virtual Interface Card drivers, complete the following steps:

1. In a web browser, navigate to <https://www.cisco.com>.
2. Under Support, click All Downloads.
3. In the product selector, click Products, then click Server - Unified Computing.
4. If prompted, enter your Cisco.com username and password to log in.



You must be signed in to download Cisco Unified Computing System (UCS) drivers.

5. Cisco UCS drivers are available for both Cisco UCS B-Series Blade Server Software and Cisco UCS C-Series Rack-Mount UCS-Managed Server Software.
6. Click UCS B-Series Blade Server Software.
7. Click Cisco Unified Computing System (UCS) Drivers.



The latest release version is selected by default. This document is built on Version 3.2(2a).

8. Click 3.2(2a) Version.
9. Download ISO image of Cisco Unified Computing System (UCS) Drivers.

10. Choose ISO image of UCS-related linux drivers only and click Download and follow the prompts to complete your driver download.
11. After the download is complete browse to \ucs-bxxx-drivers-linux.3.2.2a\Network\Cisco\VIC\SLES\SLES12.2 and copy cisco-enic-kmp-default-2.3.0.30\_k3.12.49\_11-0.x86\_64.rpm to each server.
12. ssh to the Server on the Management IP as root.
13. Update the enic driver with the following command:

```
rpm -Uvh /tmp/ cisco-enic-usnic-kmp-default-3.0.44.553.545.8_k4.4.21_69-1.x86_64.rpm
```

14. Update the enic driver on all the MapR Servers.

## Network Time

The configuration of NTP is important and must be performed on all systems. To configure network time, complete the following step:

1. Configure NTP by adding at least one NTP server to the NTP config file /etc/ntp.conf:

```
vi /etc/ntp.conf
server <NTP-SERVER IP>
fudge <NTP-SERVER IP> stratum 10
keys /etc/ntp.keys
trustedkey 1
```

## SSH Keys

The SSH Keys must be exchanged between all MapR servers for user 'root'. To exchange the SSH keys, complete the following steps:

1. Generate the rsa public key by executing the following command:

```
ssh-keygen -b 2048
Generating public/private rsa key pair.
Enter file in which to save the key (/root/.ssh/id_rsa):
Enter passphrase (empty for no passphrase):
Enter same passphrase again:
Your identification has been saved in /root/.ssh/id_rsa.
Your public key has been saved in /root/.ssh/id_rsa.pub.
The key fingerprint is:
62:8a:0b:c4:4c:d7:de:8d:dc:e7:b7:17:ca:c7:02:94 root@mapr21.ciscolab.local
The key's randomart image is:
+--[ RSA 2048]-----+
| |
| . |
| . . . . |
|+ . . o + E |
| + .o+So.. |
|. . o . o . . |
|. . . .o.o .|
| . . .+.+ |
| . .+ |
+-----+
```

2. Exchange the rsa public key by executing the below command from First server to rest of the servers. This helps ensure that every host can establish a password-less ssh connection to every other host:

```
"ssh-copy-id -i /root/.ssh/id_rsa.pub mapr31"
ssh-copy-id -i /root/.ssh/id_rsa.pub mapr32
```

- Repeat the steps above for all the servers in the MapR cluster.

## MapR Installation

The installation of the MapR software needs a repository with the MapR software packages. If the MapR cluster nodes have internet access, it is recommended to prepare an online repository. If the MapR cluster nodes do not have internet access, you can download the packages from a computer which has internet access, unzip and copy them to a server which is reachable by the MapR cluster nodes or to a MapR cluster node itself and prepare an offline repository.



The following information is required to setup the MapR Cluster.

### Cluster IDs

Cluster Name:           example: mapr600

### Virtual IP Range

For High Availability and network bandwidth distribution, virtual IPs are created on the MapR cluster. These virtual IPs are bind to HANA Storage Ethernet device. HANA servers will use these virtual IPs to mount the NFS volumes. If a MapR node is failed, the virtual IPs are moved to other active nodes and the HANA servers will continue to access NFS volumes without any disruption. Its recommended to create two virtual IP address per MapR server, for example if there are 4 MapR nodes in the cluster – Create 8 Virtual IPs.

IP Address:            example: 192.168.110.71-78

Subnet Mask:          example: 255.255.255.0 or /24

## Preparing Online Repository

On every MapR cluster node, to add the MapR repository, complete the following steps:

- Use the following command to add the repository for MapR packages:

```
zypper ar http://package.mapr.com/releases/v6.0.0/suse/ maprtech
```

- If your connection to the Internet is through a proxy server, you must set the `http_proxy` environment variable before installation:

```
http_proxy=http://<host>:<port>
export http_proxy
```

- Update the system package index by running the following command:

```
zypper refresh
```

- MapR packages require a compatibility package in order to install and run on SUSE. Execute the following command to install the SUSE compatibility package:

```
zypper install mapr-compat-suse
```

## Installing MapR Packages

Packages are installed based on the role of the node. To install the MapR packages, complete the following steps:

- Install on MapR NFS and MapR Fileserver on all nodes in the MapR Cluster:

```
zypper in mapr-nfs mapr-fileserver
```

2. Install zookeeper service on last three nodes of the MapR Cluster:

```
zypper in mapr-zookeeper
```

3. Install cldb service on first two nodes of the MapR Cluster:

```
zypper in mapr-cldb
```

4. Install webserver service on all the nodes or at least on two nodes in the MapR Cluster:

```
zypper in mapr-webserver
```

## Initial Configuration

After all packages are installed, follow the steps below to configure MapR cluster.



**WARNING!** Any changes after these steps without re-running the configuration script might result in an unstable cluster state.

1. Increase memory usage of MapR instance:

```
sed -i
's/service.command.mfs.heapsize.percent=.*service.command.mfs.heapsize.percent=8
5/g' /opt/mapr/conf/warden.conf
```

2. Define the MapR subnets to use:

```
sed -i 's%s#export MAPR_SUBNETS=%export
MAPR_SUBNETS=<<internal_network_01>>/<<subnet_short>>,<<internal_network_02>>/<<s
ubnet_short>> %g' /opt/mapr/conf/env.sh
```

Example:

```
sed -i -e 's%s#export MAPR_SUBNETS=%export
MAPR_SUBNETS=10.21.221.0/24,10.22.222.0/24 %g' /opt/mapr/conf/env.sh
```

3. Modify the DrCache size of the NFS server:

```
sed -i 's/#DrCacheSize =.*DrCacheSize = 614400/g' /opt/mapr/conf/nfsserver.conf
```

4. Create the /mapr directory and the /opt/mapr/conf/mapr\_fstab file:

```
mkdir -p /mapr
echo "localhost:/mapr /mapr hard,noexec,nonoatime 0 0" > /opt/mapr/conf/mapr_fstab
```

5. Run the configuration script. -C followed by the cldb nodes, -Z followed by the zookeeper nodes, -N gives the cluster name, and -no-autostart hinders the MapR software to start automatically. If you use hostnames instead of IP addresses for -C and -Z, be sure to use hostnames which reflect to the internal cluster network IP addresses.

```
/opt/mapr/server/configure.sh -C <<cldbnode1>>,<<cldbnode2>> -Z
<<zookeepernode1>>,<<zookeepernode2>>,<<zookeepernode3>> -N <<clustername>> -noautostart
```

Example:

```
/opt/mapr/server/configure.sh -C mapr31, mapr32 -Z mapr32,mapr33,mapr34 -N
mapr600 -no-autostart
```

6. Create a file with a disk list, containing all Virtual Drives in RAID 5 created:

```
lsblk | grep 8.2T | awk '{print "/dev/"$1}' > /tmp/disk.list
```

7. Set up the disks in the disk.list file with a storage pool of 1 disk each on all nodes:



**WARNING!** The disks will be wiped immediately!

```
/opt/mapr/server/disksetup -W 1 -F /tmp/disk.list
```

8. Repeat Step 1 through 7 on each MapR node in the cluster.

## Starting up MapR cluster

To issue the following commands to start the cluster, complete the following steps:

1. On zookeeper nodes:

```
service mapr-zookeeper start
```

2. On all nodes, including zookeeper nodes:

```
service mapr-warden start
```

3. Wait for about 5 minutes for the cluster to come up.

## Add License to MapR Cluster

To add a license to the MapR Cluster, complete the following steps:

1. When MapR Cluster is installed and running, log in to any MapR cluster node and retrieve your unique MapR cluster ID:

```
maprcli license showid
```

2. Send the cluster ID and the number of MapR nodes, along with <customer info> to <MapR> to get your MapR License.
3. If your cluster has internet access, install your license directly from the MapR License Server. Select Admin from the drop-down list and select Cluster Setting. In the Admin/ Cluster Setting click License.

Admin / Cluster Settings

Auditing | Balancer | Licenses | Quotas | Gateway | Alarms

CLUSTER INFORMATION

Type	Maximum	Available	Used
Server Nodes	4	0	4
Client Nodes - Basic	10	-	-
Client Nodes - PACC	10	-	-

Cluster ID: 14328306317507737

Add Licenses Using the Following Options:

[Import License](#) [Upload License File](#) [Copy/Paste License](#)

MapR's free trial license will allow you to get a license to try one of MapR's many services for a short period. [Get a Free Trial License](#)

- Select Import License, enter the credentials for mapr.com Account to retrieve the license.

Import License

To be able to retrieve your license information, please enter your log in credentials for My Account on mapr.com.

User Name:

Password:

[Log in](#)

[Submit](#) [Cancel](#)

- Alternatively, if your cluster does not have internet access, you can copy your license file to any MapR cluster node, and install it via the command line interface:

```
maprcli license add -is_file true -license <license_file>
```



The MapR license file is a text file starting with the line "-----BEGIN SIGNED MESSAGE-----" and ending with the line "-- --END MESSAGE HASH-----". You can also use "Add licenses via upload" or "Add licenses via copy/paste" in the "Manage Licenses" dialog in the MapR Control System GUI to install the license from a file.

## Create Virtual IPs

In order to create virtual IP addresses for the MapR NFS server, MAC address of HANA-Storage vNIC on all the MapR nodes, IP address range for Virtual IP and Network subnet are required.

From each MapR Server execute `ifconfig -a |grep HWaddr` command to get list of Ethernet device with MAC Address. By comparing MAC Address on the OS and Cisco UCS Service Profile, eth2 on OS will carry the VLAN for HANA-Storage.

```
ifconfig -a |grep HWaddr
eth0 Link encap:Ethernet HWaddr 00:25:B5:2A:00:2C
eth1 Link encap:Ethernet HWaddr 00:25:B5:2B:00:28
eth2 Link encap:Ethernet HWaddr 00:25:B5:2B:00:29
eth3 Link encap:Ethernet HWaddr 00:25:B5:2A:00:2E
```

```
Below is the command to create Virtual IP on the MapR cluster:
maprcli virtualip add -macs <mac_addr_node1> <mac_addr_node2> <mac_addr_nodeN> -
virtualipend <<last_virtual_ip>> -netmask <<subnet_mask> -virtualip
<<first_virtual_ip>>
```

**Example:**

```
maprcli virtualip add -macs 00:25:b5:fb:00:29 00:25:b5:fb:00:22 00:25:b5:fb:00:24
00:25:b5:fb:00:26 -virtualipend 192.168.110.78 -netmask 255.255.255.0 -virtualip
192.168.110.71
```

## Create Volumes

The MapR cluster needs an internal directory structure for its volumes. It is recommended to store the volumes in the /apps folder of the MapR cluster directory structure. The MapR file system is mounted on the MapR cluster nodes under /mapr, so the following directory structure should be created on one of the MapR cluster node.

1. Confirm MapR file system is mounted at /mapr:

```
mount | grep mapr
localhost:/mapr on /mapr type nfs (rw,nolock,addr=127.0.0.1)
```

2. Create HANA directory:

```
mkdir -p /mapr/<clustername>/apps/hana/<SID>
```

**Example:**

```
mkdir -p /mapr/mapr600/apps/hana/ANA
```



When creating a volume, the volume name can differ from the directory name of MapR internal file system.

3. Create volume for /hana/shared:

```
maprcli volume create -name <volumename> -path /apps/hana/<SID>/<volumename> -
replicationtype high_throughput -replication 2 -minreplication 2
```

4. Create volumes for /hana/data for every single storage partition:

```
maprcli volume create -name <volumename> -path
/apps/hana/<SID>/<datamountpoint_storage_partition> -replicationtype
high_throughput -replication 2 -minreplication 2
```

5. Create volumes for /hana/log for every single storage partition:

```
maprcli volume create -name <volumename> -path
/apps/hana/<SID>/<logmountpoint_storage_partition> -replicationtype low_latency -
replication 2 -minreplication 2
```

6. Turn off the compression for log volumes:

```
hadoop mfs -setcompression off /mapr/<clustername>/apps/hana/<SID>/<volumename>
```



It is recommended to reflect the SID in the path. For the three different volume types shared, data and log.

7. Example for creating a volume for /hana/shared for SID "ANA":

```
maprcli volume create -name shared -path /apps/hana/ANA/shared -replicationtype
high_throughput -replication 2 -minreplication 2
```

### 8. Example for creating eight volumes for /hana/data for SID "ANA":

```
maprcli volume create -name data001 -path /apps/hana/ANA/data001 -replicationtype
high_throughput -replication 2 -minreplication 2
maprcli volume create -name data002 -path /apps/hana/ANA/data002 -replicationtype
high_throughput -replication 2 -minreplication 2
maprcli volume create -name data003 -path /apps/hana/ANA/data003 -replicationtype
high_throughput -replication 2 -minreplication 2
maprcli volume create -name data004 -path /apps/hana/ANA/data004 -replicationtype
high_throughput -replication 2 -minreplication 2
maprcli volume create -name data005 -path /apps/hana/ANA/data005 -replicationtype
high_throughput -replication 2 -minreplication 2
maprcli volume create -name data006 -path /apps/hana/ANA/data006 -replicationtype
high_throughput -replication 2 -minreplication 2
maprcli volume create -name data007 -path /apps/hana/ANA/data007 -replicationtype
high_throughput -replication 2 -minreplication 2
maprcli volume create -name data008 -path /apps/hana/ANA/data008 -replicationtype
high_throughput -replication 2 -minreplication 2
```

### 9. Example for creating eight volumes for /hana/log for SID "ANA":

```
maprcli volume create -name log001 -path /apps/hana/ANA/log001 -replicationtype
low_latency -replication 2 -minreplication 2
maprcli volume create -name log002 -path /apps/hana/ANA/log002 -replicationtype
low_latency -replication 2 -minreplication 2
maprcli volume create -name log003 -path /apps/hana/ANA/log003 -replicationtype
low_latency -replication 2 -minreplication 2
maprcli volume create -name log004 -path /apps/hana/ANA/log004 -replicationtype
low_latency -replication 2 -minreplication 2
maprcli volume create -name log005 -path /apps/hana/ANA/log005 -replicationtype
low_latency -replication 2 -minreplication 2
maprcli volume create -name log006 -path /apps/hana/ANA/log006 -replicationtype
low_latency -replication 2 -minreplication 2
maprcli volume create -name log007 -path /apps/hana/ANA/log007 -replicationtype
low_latency -replication 2 -minreplication 2
maprcli volume create -name log008 -path /apps/hana/ANA/log008 -replicationtype
low_latency -replication 2 -minreplication 2
```

### 10. Example to turn off compression on eight log volumes for SID "ANA":

```
hadoop mfs -setcompression off /mapr/mapr600/apps/hana/ANA/log001
hadoop mfs -setcompression off /mapr/mapr600/apps/hana/ANA/log002
hadoop mfs -setcompression off /mapr/mapr600/apps/hana/ANA/log003
hadoop mfs -setcompression off /mapr/mapr600/apps/hana/ANA/log004
hadoop mfs -setcompression off /mapr/mapr600/apps/hana/ANA/log005
hadoop mfs -setcompression off /mapr/mapr600/apps/hana/ANA/log006
hadoop mfs -setcompression off /mapr/mapr600/apps/hana/ANA/log007
hadoop mfs -setcompression off /mapr/mapr600/apps/hana/ANA/log008
```



MapR FS is a distributed File System, there should be quota set for each volume to restrict the volume size. Hard quota, which raises an alarm when the threshold is reached and prevents further writes. Advisory quota, which raises an alarm when the threshold is reached, but does not prevent further writes. Every volume will be set with quota as per SAP's recommended volume size. Advisory quota will be set at 85% of recommended volume size.

### 11. Shared filesystem should be 1 x Memory for every 4 servers. Set Quota for /hana/shared for SID ANA"

```
maprcli volume modify -name shared -advisoryquota 5223G -quota 6144G
```

### 12. Data volume should be 3 x Memory. Set Quota for eight data volumes for SID "ANA":

```
maprcli volume modify -name data001 -advisoryquota 7834G -quota 9216G
maprcli volume modify -name data002 -advisoryquota 7834G -quota 9216G
maprcli volume modify -name data003 -advisoryquota 7834G -quota 9216G
```



```
maprcli volume modify -name data004 -advisoryquota 7834G -quota 9216G
maprcli volume modify -name data005 -advisoryquota 7834G -quota 9216G
maprcli volume modify -name data006 -advisoryquota 7834G -quota 9216G
maprcli volume modify -name data007 -advisoryquota 7834G -quota 9216G
maprcli volume modify -name data008 -advisoryquota 7834G -quota 9216G
```

**13. Log volume should be 512 GB. Set Quota for eight log volumes for SID "ANA":**

```
maprcli volume modify -name log001 -advisoryquota 435G -quota 512G
maprcli volume modify -name log002 -advisoryquota 435G -quota 512G
maprcli volume modify -name log003 -advisoryquota 435G -quota 512G
maprcli volume modify -name log004 -advisoryquota 435G -quota 512G
maprcli volume modify -name log005 -advisoryquota 435G -quota 512G
maprcli volume modify -name log006 -advisoryquota 435G -quota 512G
maprcli volume modify -name log007 -advisoryquota 435G -quota 512G
maprcli volume modify -name log008 -advisoryquota 435G -quota 512G
```

## HANA System Configuration

---

This section provides the procedure for SUSE Linux Enterprise Server for SAP Applications 12 SP 2 Operating System and customizing for SAP HANA requirement.



For the latest information on SAP HANA installation and OS customization requirement, see the [SAP HANA Installation Guide](#).

---

### SUSE Operating System Installation

To install the SUSE Linux Enterprise Server for SAP Applications 12 SP 2 on the local drives, complete the following steps:

1. In Cisco UCS Manager, click the Servers tab in the navigation pane.
2. Select Service Profile > root > Sub-Organization > HANA > HANA-Server01.
3. Click KVM Console.
4. When the KVM Console is launched, click Boot Server.
5. Click Virtual Media > Activate Virtual Devices.
  - a. Select the option Accept this Session for Unencrypted Virtual Media Session and then click Apply.
  - b. Click Virtual Media and Choose Map CD/DVD.
  - c. Click Browse to navigate ISO media location.
  - d. Click Map Device.
6. On the Initial screen select Installation to begin the installation process.

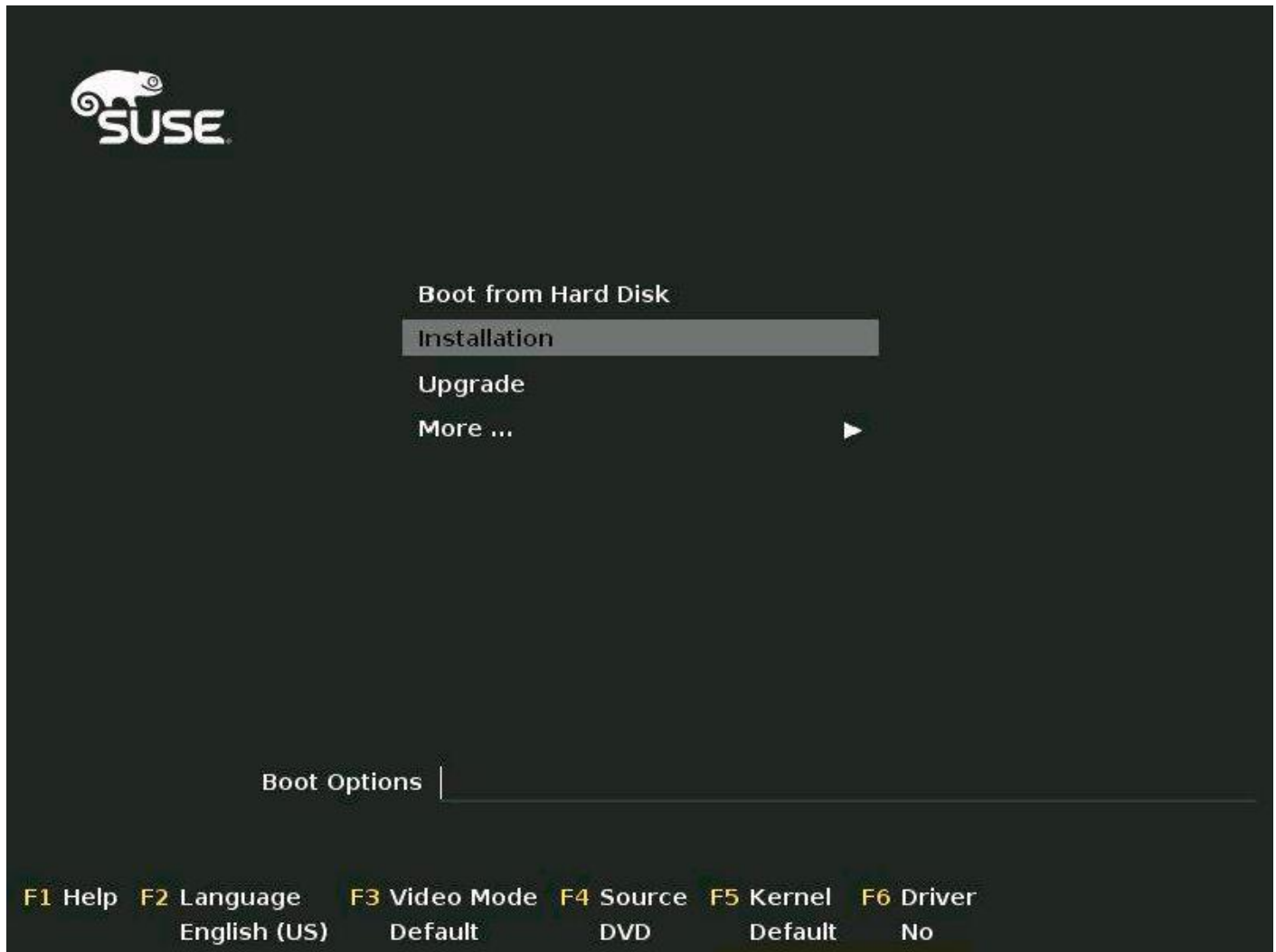

7. Choose Language and Keyboard layout and Select I Agree the License Terms and click Next.

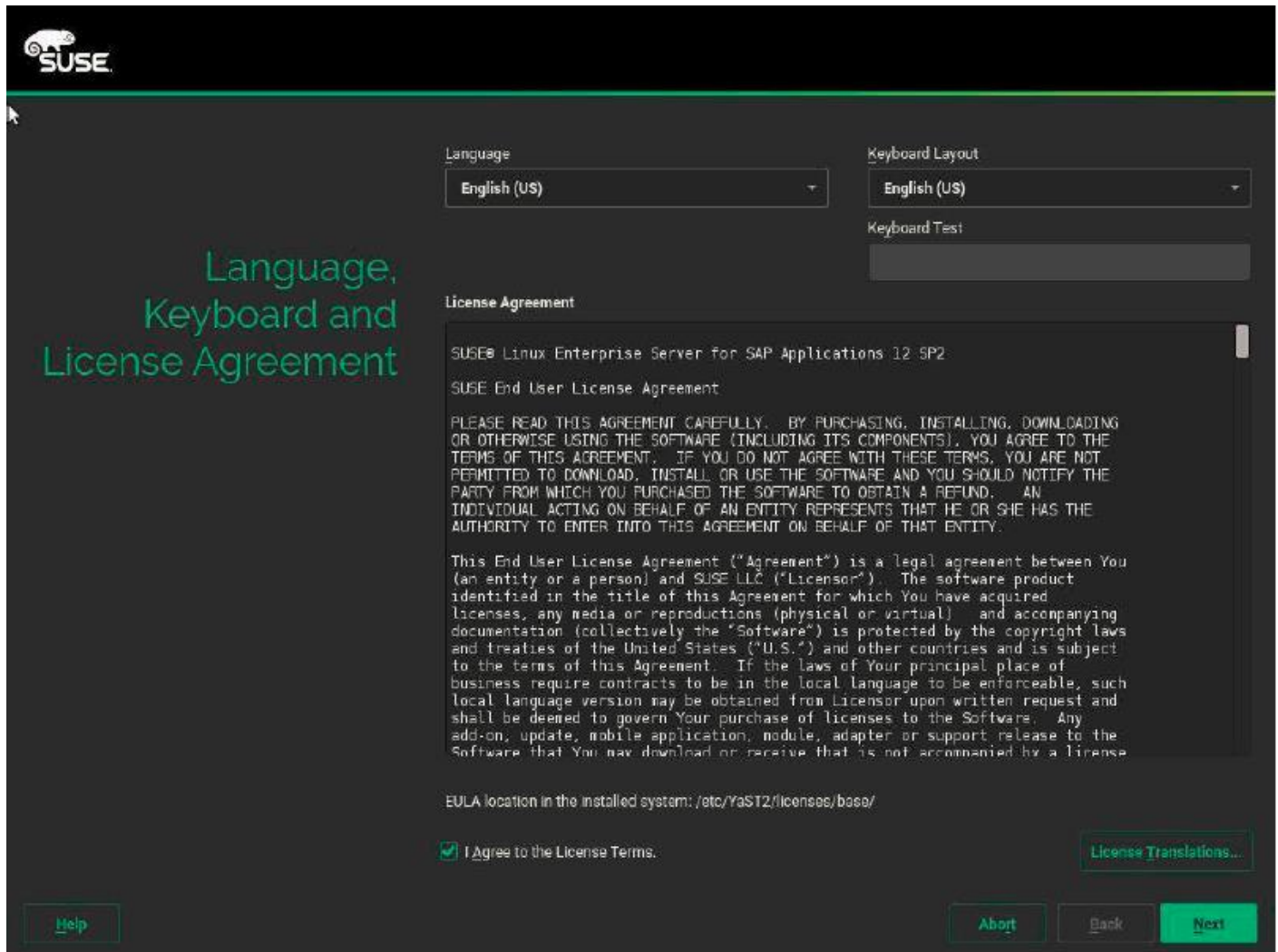

8. On the Network Settings screen Under Overview, click vNIC Ethernet NIC.
9. To configure the network interface on the OS, it is required to identify the mapping of the Ethernet device on the OS to vNIC interface on the Cisco UCS.
  - a. In Cisco UCS Manager, click the Servers tab in the navigation pane.
  - b. Expand Servers > Service Profile > root > Sub-Organization > HANA > HANA-Server01.
  - c. Click + to Expand.
  - d. Click vNICs.
  - e. On the right pane list of the vNICs with MAC Address are listed.

vNICs

<span>▼ Advanced Filter</span> <span>↑ Export</span> <span>🖨 Print</span>				
Name	MAC Address	Desired O... ▼	Actual Order	Fabric ID
vNIC HANA-Internal	00:25:B5:2A:00:00	1	1	A B
vNIC HANA-Storage	00:25:B5:2B:00:00	2	2	B A
vNIC HANA-AppServer	00:25:B5:2A:00:01	3	3	A B
vNIC HANA-Client	00:25:B5:2B:00:01	4	4	B A
vNIC Mgmt	00:25:B5:2A:00:02	5	5	A B
vNIC HANA-Backup	00:25:B5:2B:00:02	6	6	B A

🗑 Delete
➕ Add
⚙ Modify

- f. Note that the MAC Address of the Mgmt vNIC is “00:25:B5:2A:00:02”.
  - g. With the vNIC order in the Service Profile, vNIC for Management should be eth4.
10. By comparing MAC Address on the OS and Cisco UCS, eth4 on OS will carry the VLAN for Management.
  11. Click Edit, under the Address tab.
  12. Click Statically Assigned IP Address:
    - a. In the IP Address field enter <<Management IP address>>.
    - b. In the Subnet Mask field enter <<subnet mask for Management Interface>>.
    - c. In the Hostname field enter the hostname for Management Interface.

The screenshot shows the 'Network Card Setup' window in SUSE, with the 'Address' tab selected. The 'Device Type' is set to 'Ethernet' and the 'Configuration Name' is 'eth3'. The 'Dynamic Address' option is selected, with 'DHCP' chosen for the address type and 'DHCP both version 4 and 6' for the version. The 'Statically Assigned IP Address' option is also visible. The 'IP Address' field contains '192.168.196.211', the 'Subnet Mask' is '255.255.255.0', and the 'Hostname' is 'cishanaso11'. Below these fields is a table for 'Additional Addresses' with columns for 'IPv4 Address Label', 'IP Address', and 'Netmask'. At the bottom, there are buttons for 'Add', 'Edit', 'Delete', 'Help', 'Cancel', 'Back', and 'Next'.

**Network Card Setup**

General | **Address** | Hardware

Device Type: Ethernet

Configuration Name: eth3

No Link and IP Setup (Bonding Slaves)  Use IBFT Values

Dynamic Address: DHCP | DHCP both version 4 and 6

Statically Assigned IP Address

IP Address: 192.168.196.211 | Subnet Mask: 255.255.255.0 | Hostname: cishanaso11

Additional Addresses

IPv4 Address Label	IP Address	Netmask

Buttons: Add, Edit, Delete, Help, Cancel, Back, Next

13. Repeat Steps 9-12 for each VNIC device.

14. On the Network Settings screen Select Hostname/DNS:

- a. In the Hostname field enter the Hostname.
- b. In the Domain Name Field enter the Domain Name.
- c. In the Name Server 1 field enter <<DNS server1>> and Name Server 2 field enter <<DNS server2>>.
- d. In the Search domains field enter <<domain1.com,domain2.com>>.
- e. Click Routing.

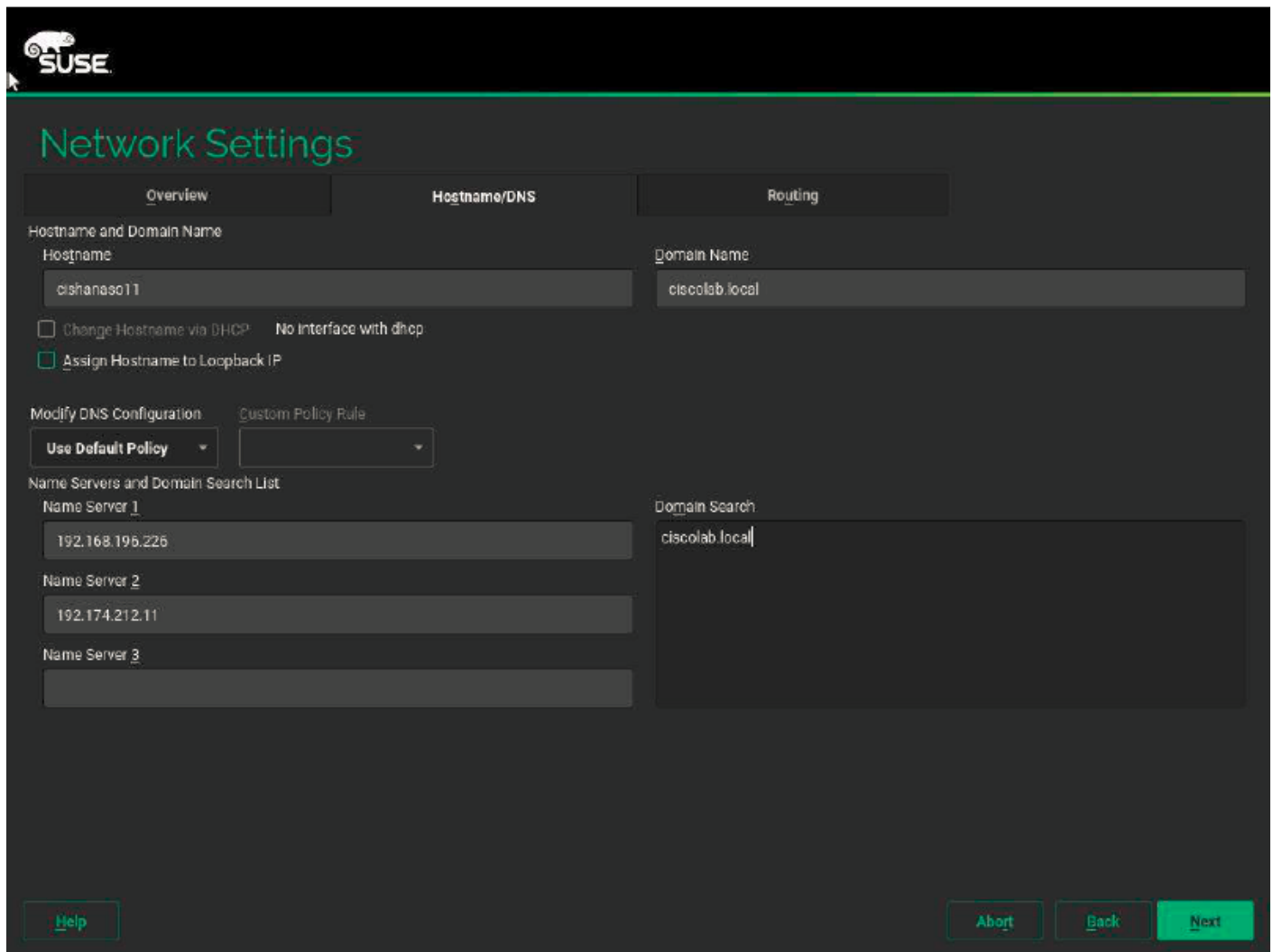

- f. For the Default IPv4 Gateway enter the <<Default Gateway for>>.
- g. Click Next.

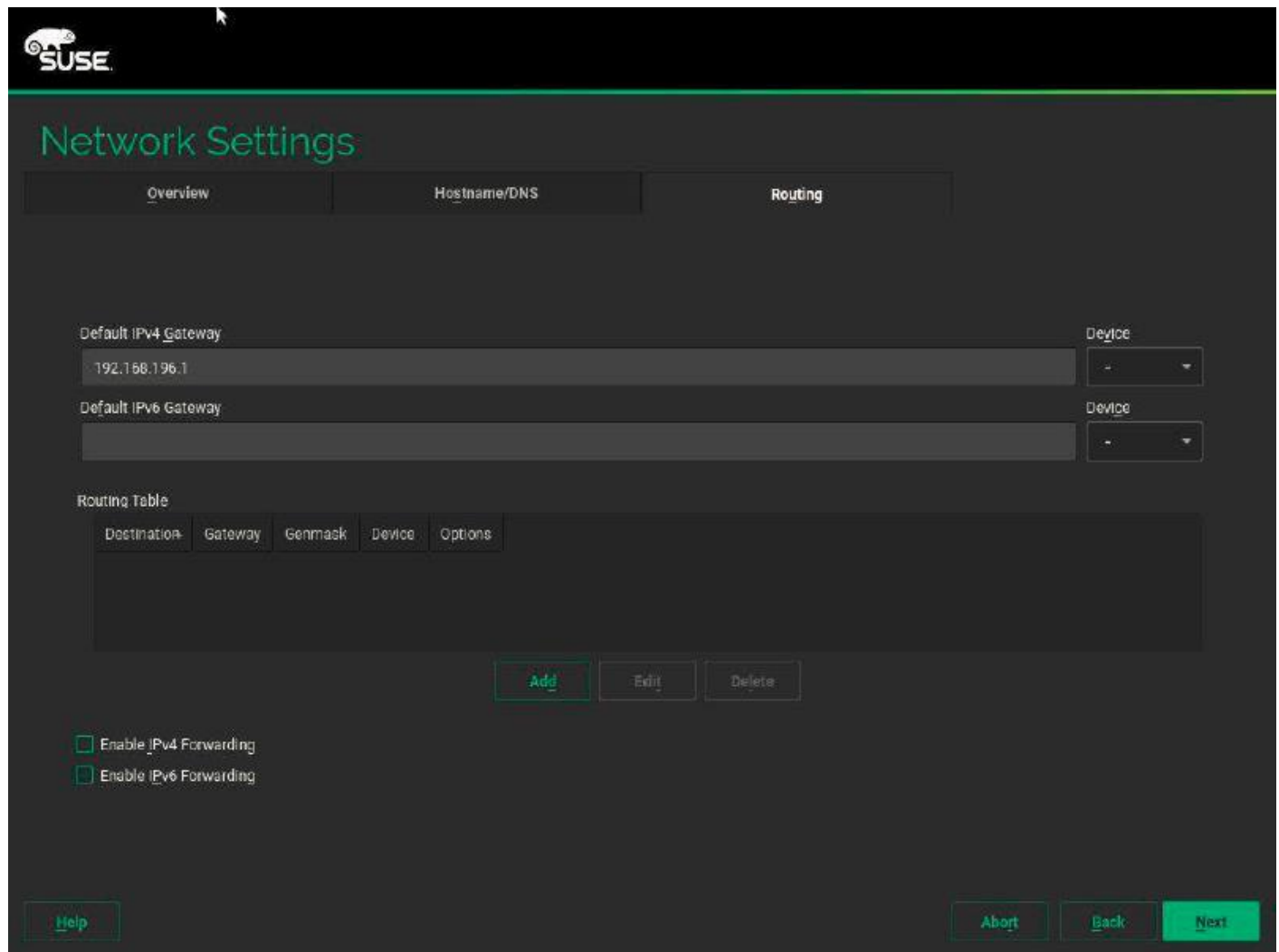

15. In the Registration screen and click Skip Registration. You will update the system in the following section.
16. In the Product Installation Mode, select Proceed with standard SLES for SAP Application installation.



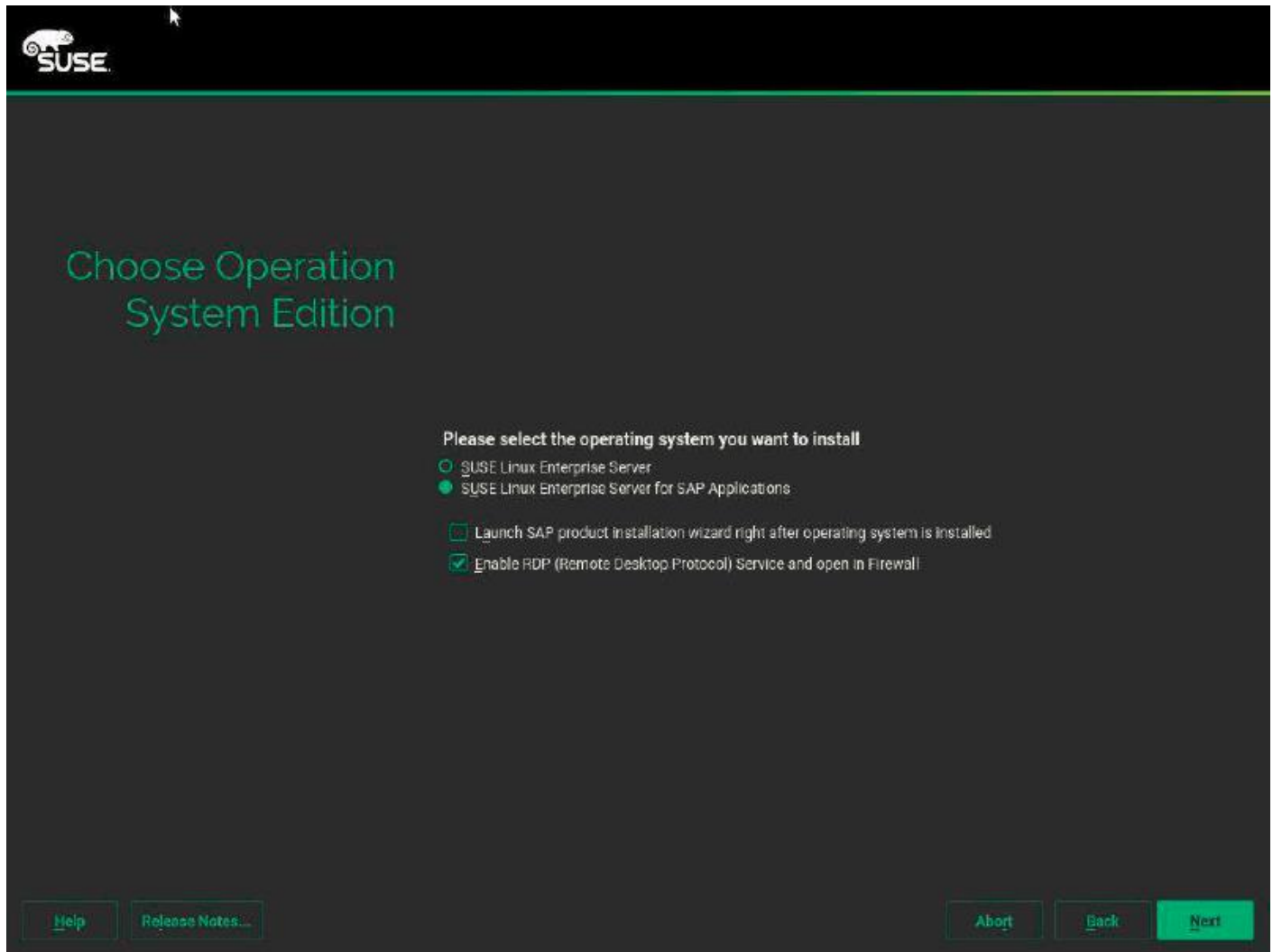

17. In the Add On Product screen and click Next.
18. In the Suggested Partitioning screen click Expert Partitioner.
19. In the Expert Partitioner screen, select the first Internal Drive /dev/sda for Operating System click Add Partition.

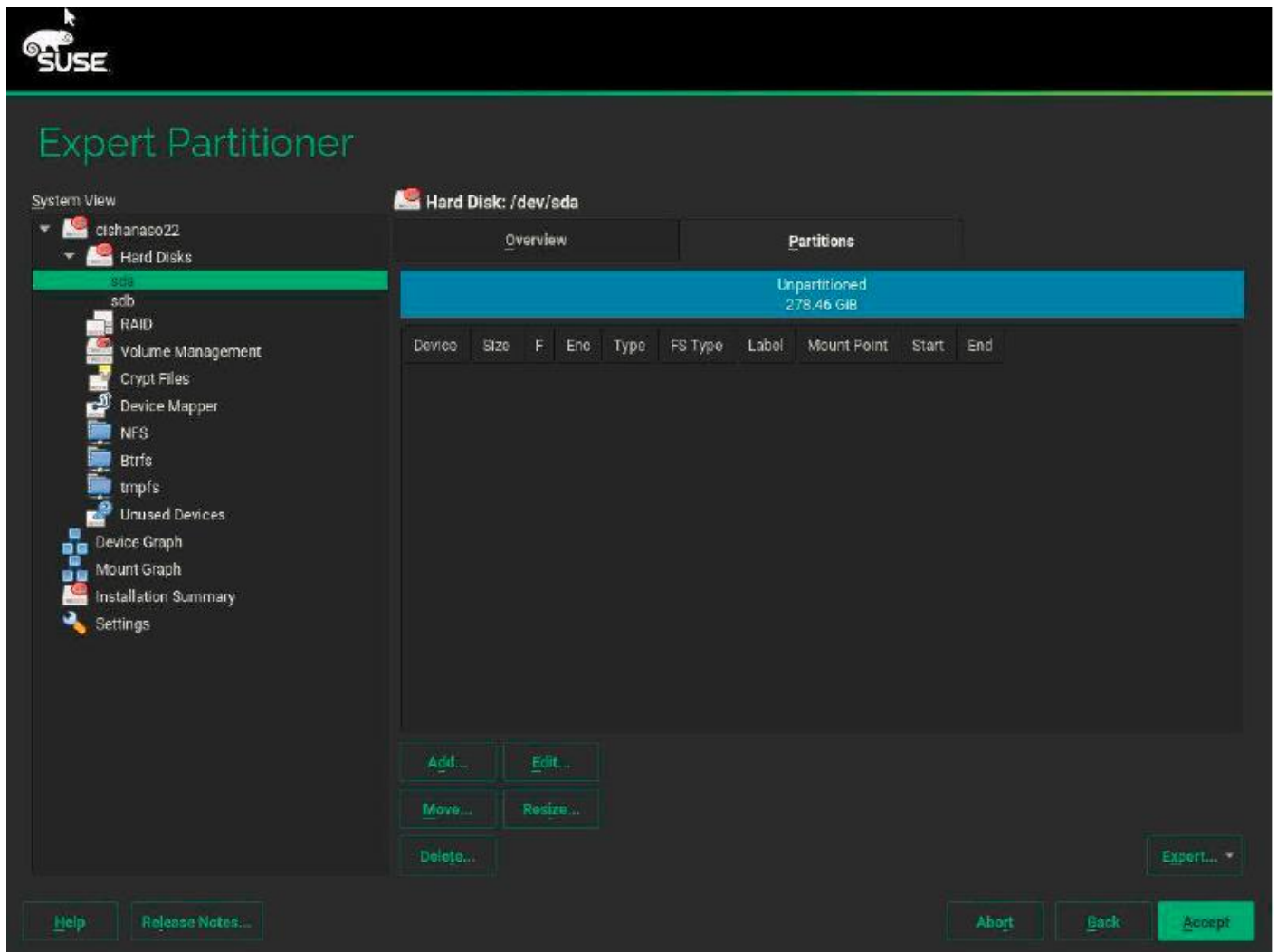

20. In the Add Partition on /dev/sda, select Primary Partition and click Next.
21. For the New Partition Size, select Custom Size.
22. In the Size field enter 200 MB and click Next.

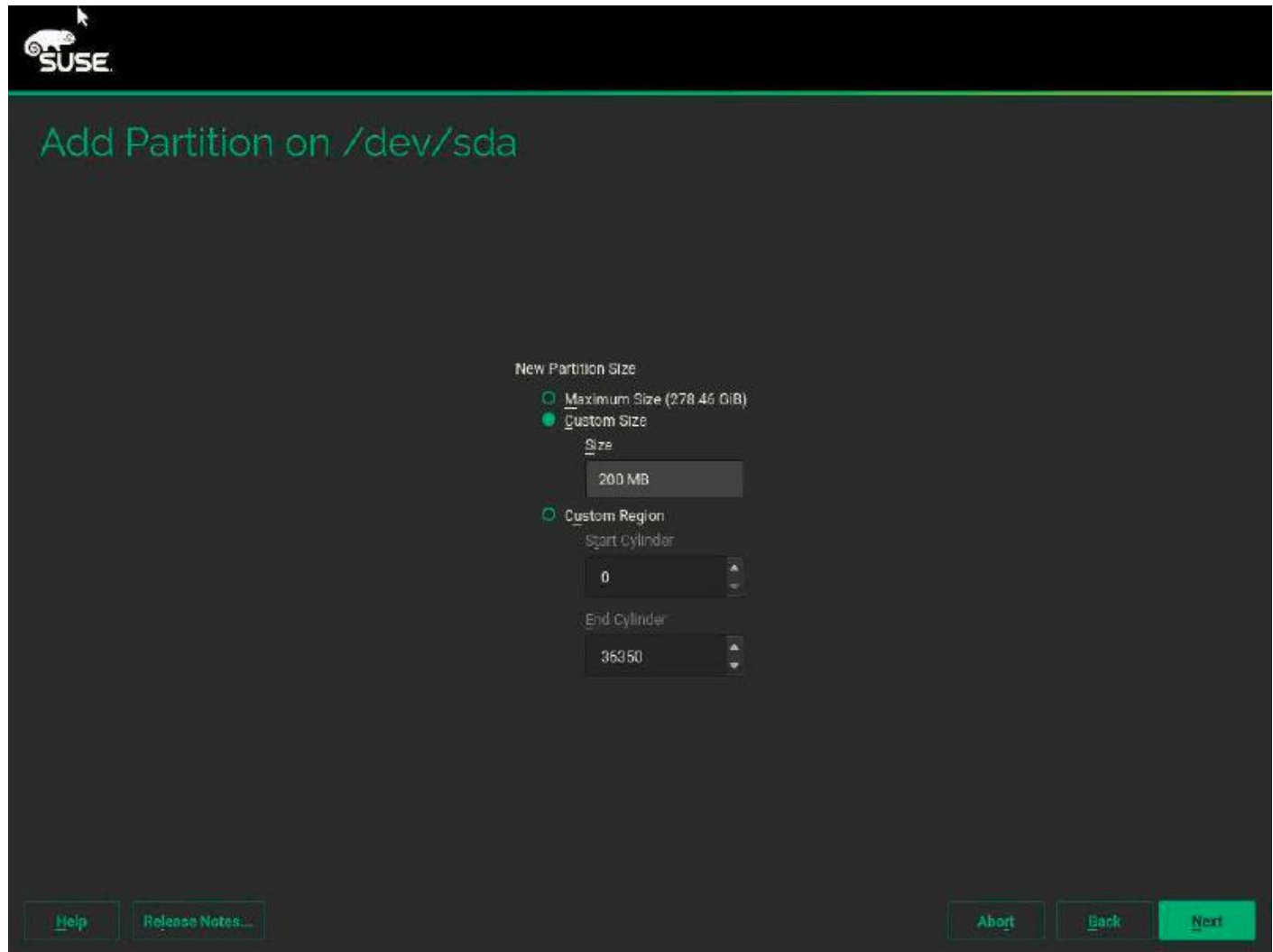

23. For Role select Operating System and click Next.
24. Select Format Partition; for File System type select ext3.
25. Select Mount Partition and Enter /boot for Mount Point.
26. Click Finish.
27. For Drive /dev/sda, click Add Partition.
28. In the Add Partition on /dev/sda, select Primary Partition and click Next.
29. For Role select Operating System, and click Next.
30. For the New Partition Size, select Custom Size.
31. In the Size field enter 2 GiB and click Next.

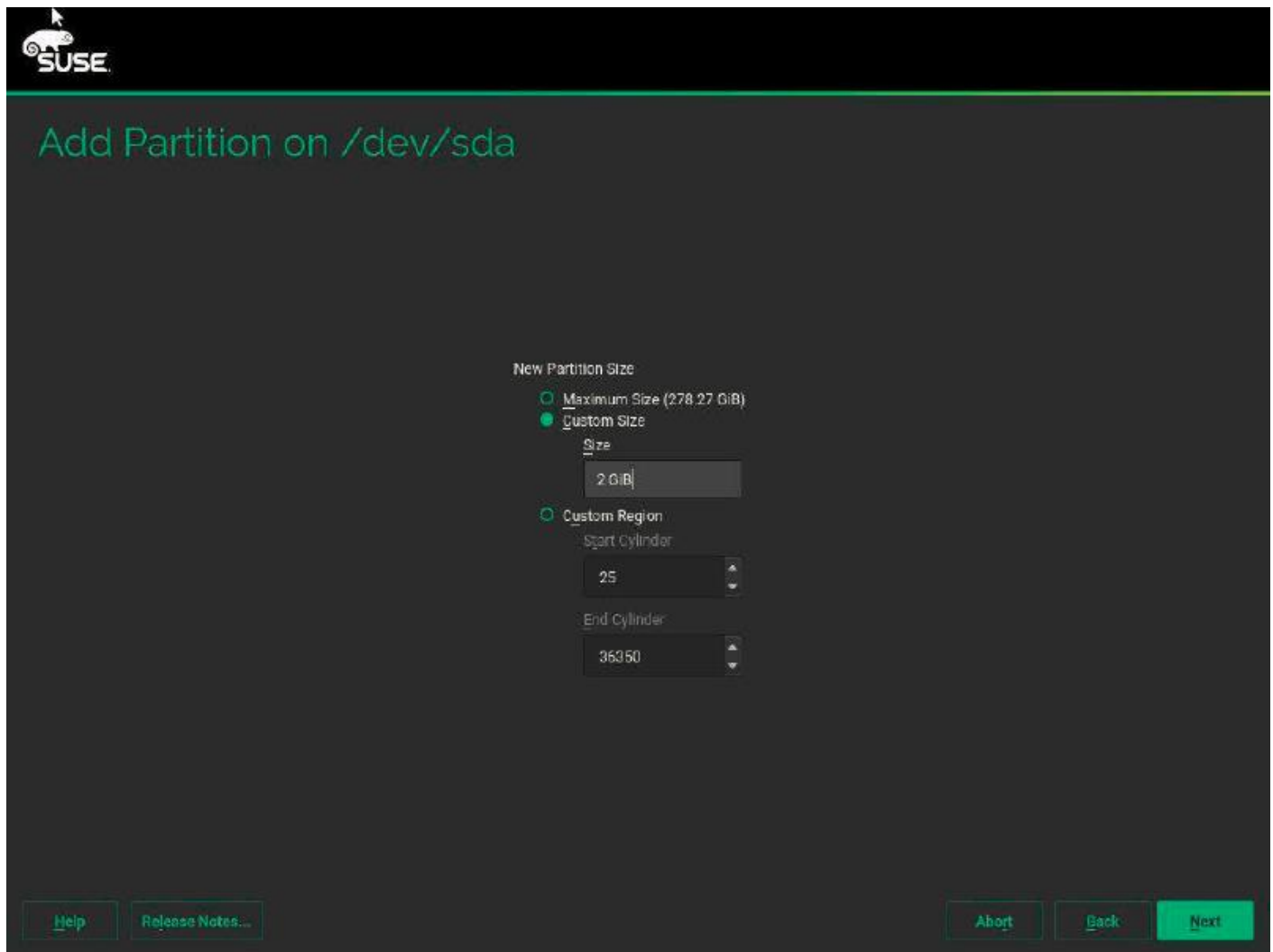

32. For Role select Swap and click Next.

33. Keep the default for File System to swap and Mount Point to swap.

34. Click Finish.

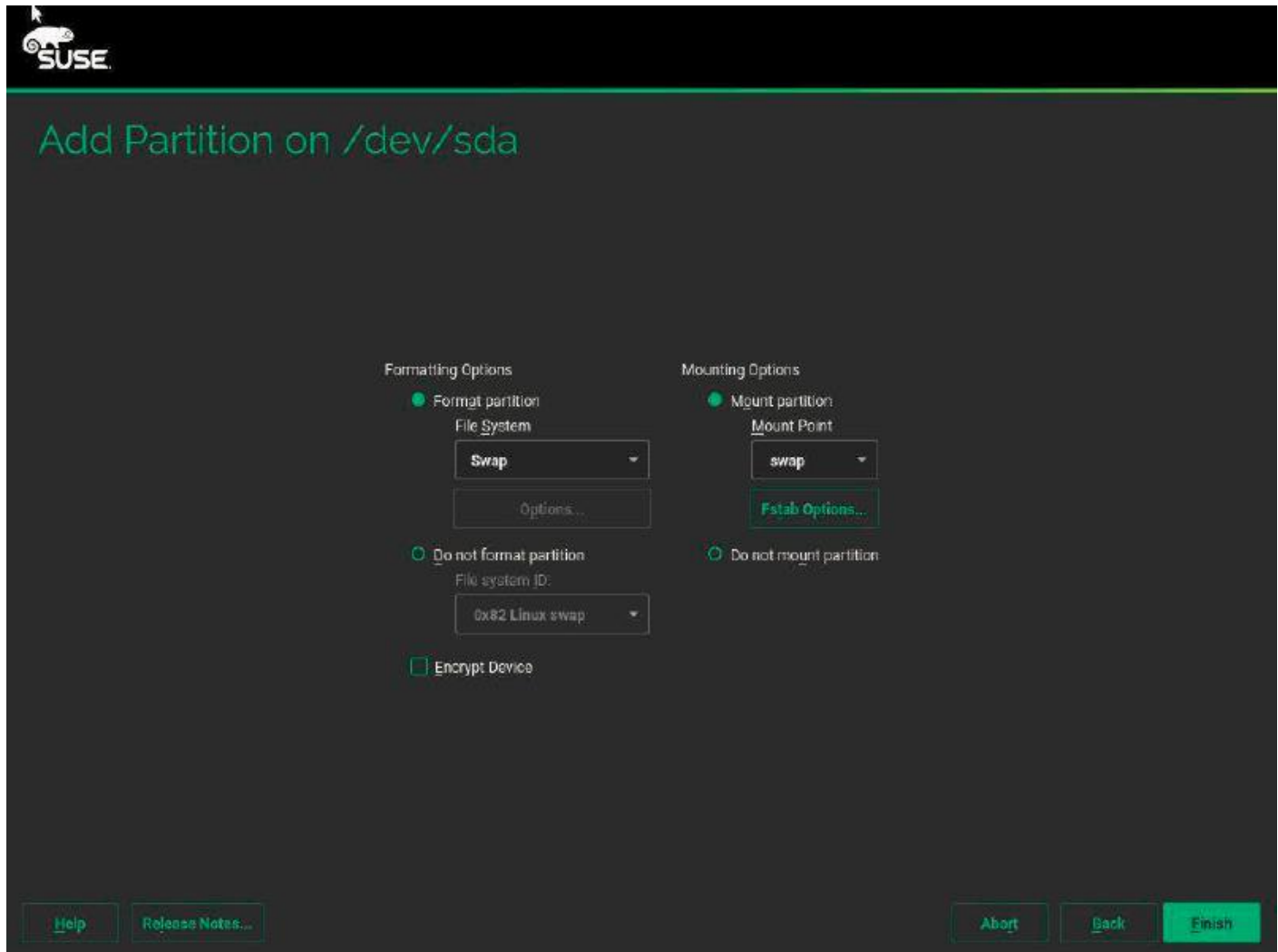

35. For Drive /dev/sda, click Add Partition.
36. In the Add Partition on /dev/sda, select Primary Partition and click Next.
37. For the New Partition Size, select Custom Size.
38. In the Size field enter 100 GiB and click Next.
39. For Role select Operating System and click Next.
40. Select Format Partition, For File System type select ext3.
41. For Mount Partition and select / for Mount Point.
42. Click Finish.

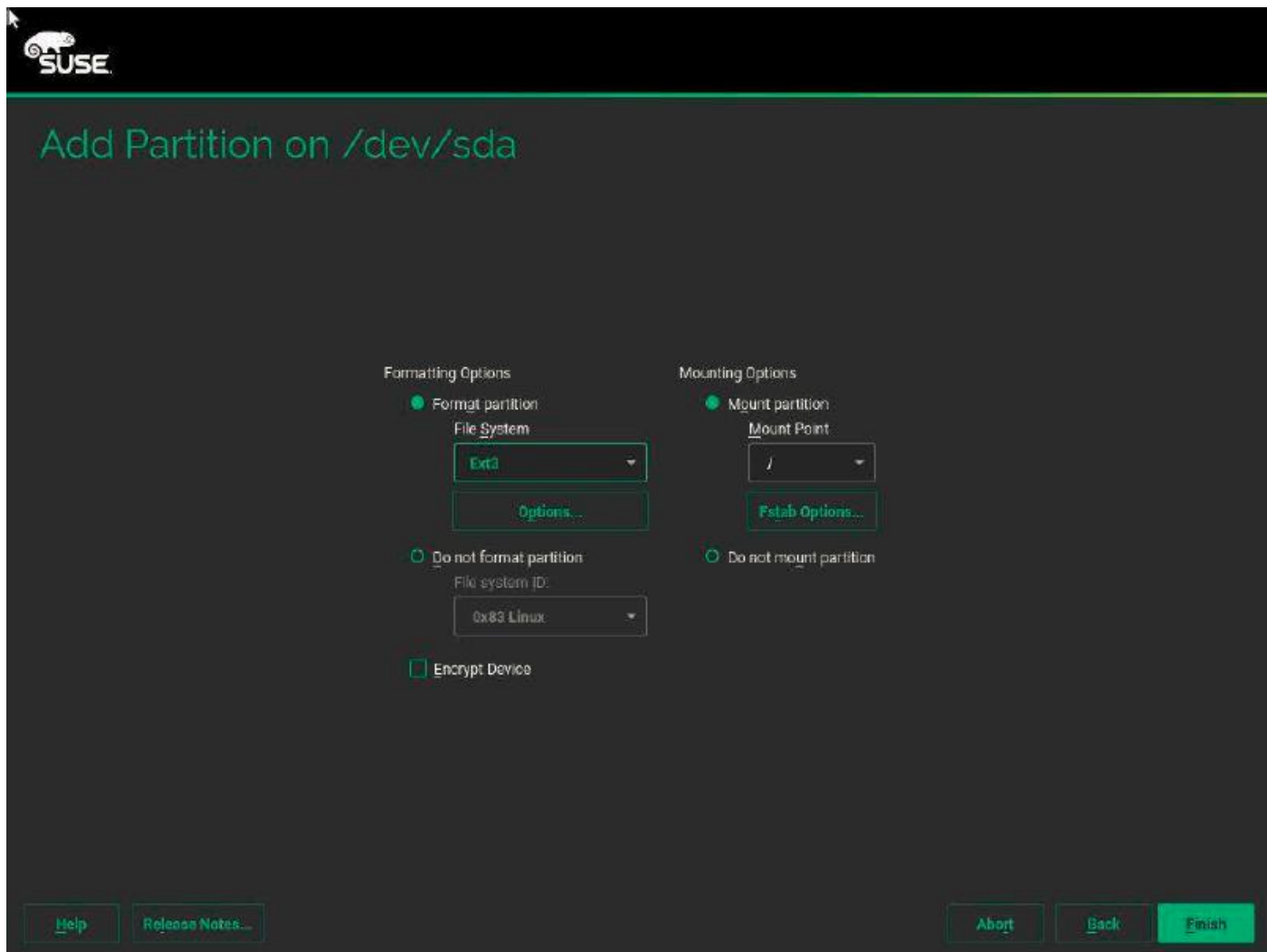

43. In the Expert Partitioner screen, click Accept.

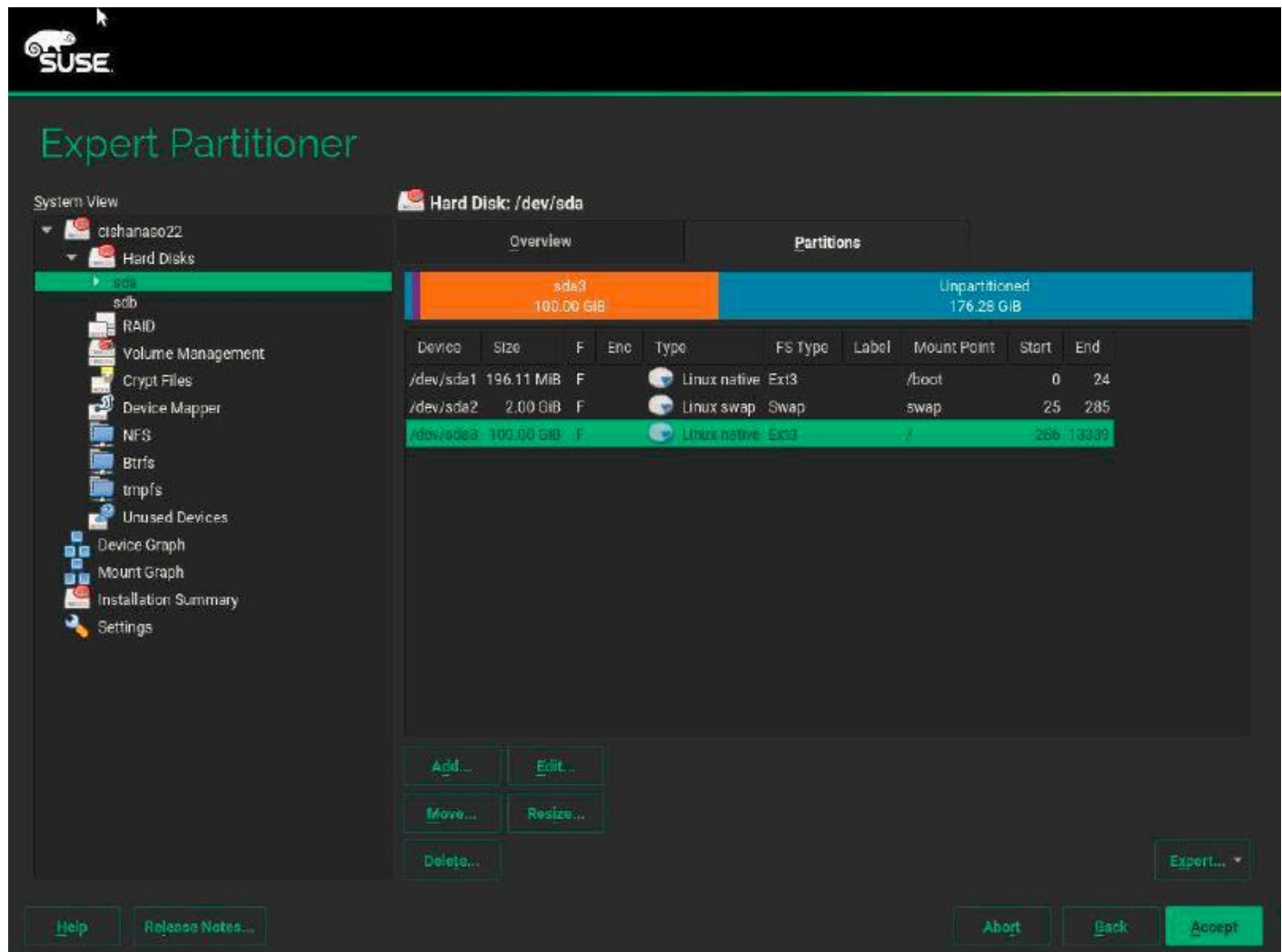

44. In the Suggested Partitioning screen click Next.

45. Select the appropriate Time Zone and click Next.

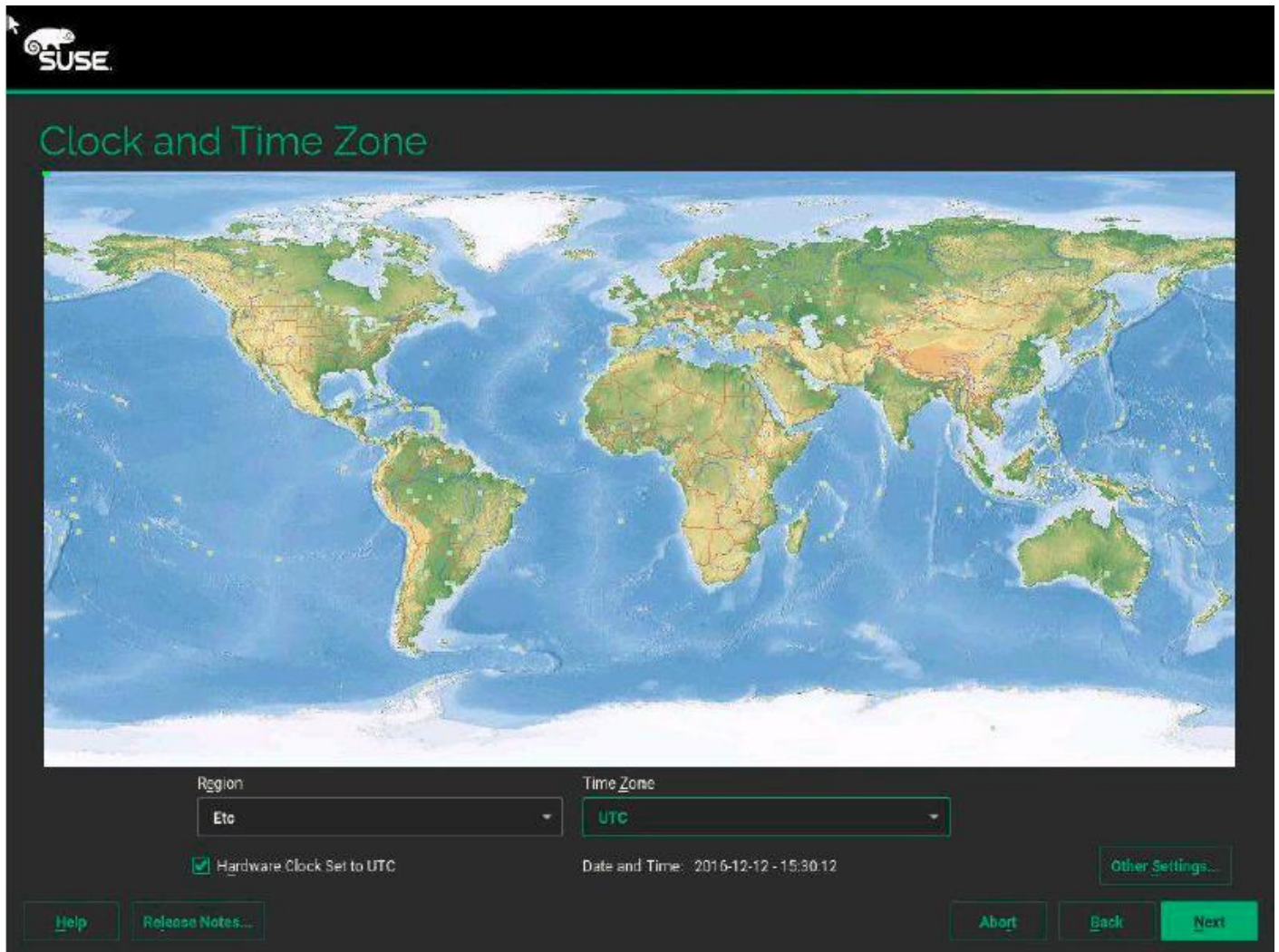

46. Enter the Password for System Administrator “root” and Confirm Password, then click Next.

47. In the Installation Settings screen click Software.



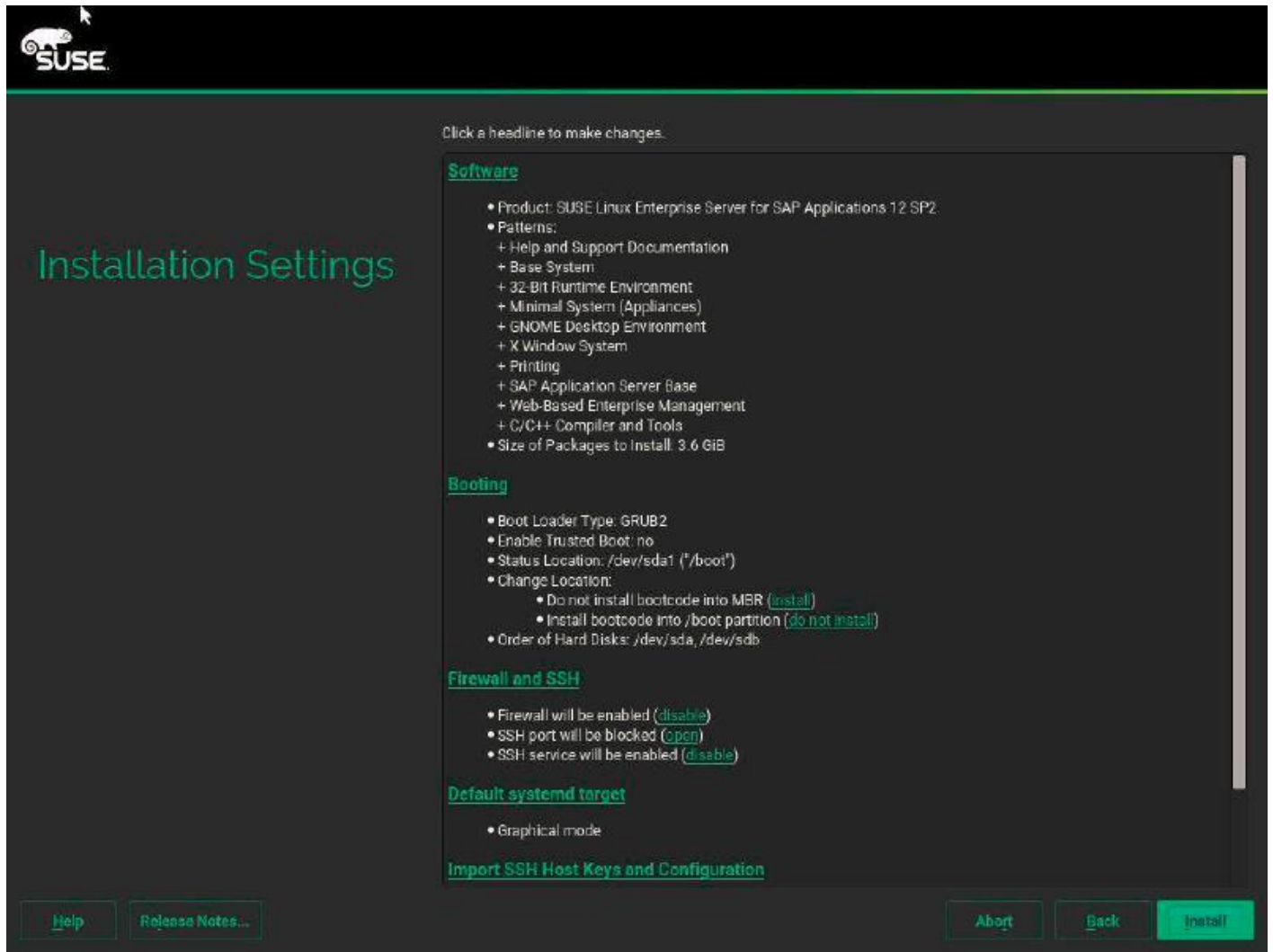

48. Select SAP HANA Server Base.

49. Click OK.

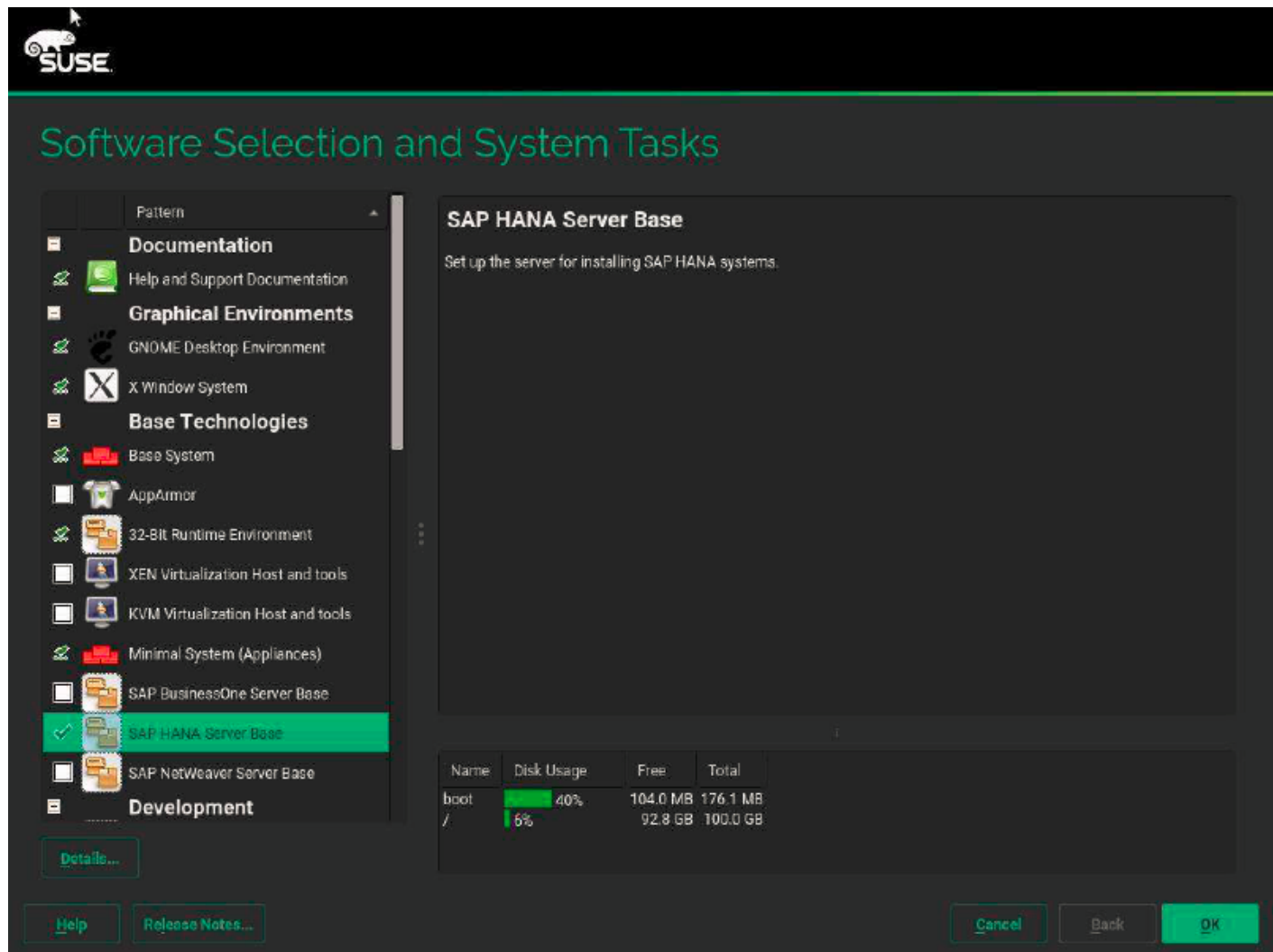

50. In the Installation Settings screen under Firewall and SSH, click Firewall will be enabled(disabled) to disable Firewall.
51. In the Installation Settings screen click Default Systemd Target.
52. Select Text mode for Available Targets and click OK.
53. In the Installation Settings screen, click Install.
54. In the Confirm Installation screen, click Install.
55. The Install process will begin and the System will reboot after OS Installation.

## Operating System Network Configuration

To customize the server in preparation for the HANA Installation, complete the following steps:

### Hostnames



The operating system must be configured in such a way that the short name of the server is displayed for the command 'hostname' and Full Qualified Host Name is displayed with the command 'hostname -d'.

1. ssh to the Server using Management IP address assigned to the server during installation.
2. Login as root and password.
3. Edit the Hostname:

```
vi /etc/HOSTNAME
<<hostname>>.<<Domain Name>>
```

**IP Address**

Each SAP HANA Server is configured with 9 vNIC device. Table 12 lists the IP Address information required to configure the IP address on the Operating System.



The IP Address and Subnet Mask provided below are examples only, please configure the IP address for your environment.

**Table 12 IP Addresses for SAP HANA Server**

vNIC Name	VLAN ID	IP Address Range	Subnet Mask
HANA-AppServer	<<var_appserver_vlan_id>>	192.168.223.211 to 192.168.223.218	255.255.255.0
HANA-Backup	<<var_backup_vlan_id>>	192.168.221.211 to 192.168.211.218	255.255.255.0
HANA-Client	<<var_client_vlan_id>>	192.168.222.211 to 192.168.222.218	255.255.0.0
HANA-DataSource	<<var_datasource_vlan_id>>	192.168.224.211 to 192.168.224.218	255.255.255.0
HANA-Internal	<<var_internal_vlan_id>>	192.168.220.211 to 192.168.220.218	255.255.255.0
HANA-Replication	<<var_replication_vlan_id>>	192.168.225.211 to 192.168.225.218	255.255.255.0
HANA-Storage	<<var_storage_vlan_id>>	192.168.110.211 to 192.168.110.218	255.255.255.0
Management	<<var_mgmt_vlan_id>>	192.168.196.211 to 192.168.196.218	255.255.0.0
NFS-IPMI	<<var_inband_vlan_id>>	192.168.197.211 to 192.168.197.218	255.255.255.0

1. To configure the network interface on the OS, it is required to identify the mapping of the ethernet device on the OS to vNIC interface on the Cisco UCS.
2. From the OS execute the below command to get list of Ethernet device with MAC Address:

```
ifconfig -a |grep HWaddr
eth0 Link encap:Ethernet HWaddr 00:25:B5:2A:00:00
eth1 Link encap:Ethernet HWaddr 00:25:B5:2B:00:00
eth2 Link encap:Ethernet HWaddr 00:25:B5:2A:00:01
eth3 Link encap:Ethernet HWaddr 00:25:B5:2B:00:01
eth4 Link encap:Ethernet HWaddr 00:25:B5:2A:00:02
eth5 Link encap:Ethernet HWaddr 00:25:B5:2B:00:02
eth6 Link encap:Ethernet HWaddr 00:25:B5:2A:00:03
eth7 Link encap:Ethernet HWaddr 00:25:B5:2B:00:03
```

```
eth8 Link encap:Ethernet HWaddr 00:25:B5:2A:00:04
```

3. In Cisco UCS Manager, click the Servers tab in the navigation pane.
4. Expand Servers > Service Profile > root > Sub-Organization > HANA > HANAServer01.
5. Click + to Expand.
6. Click vNICs.
7. On the right pane list of the vNICs with MAC Address are listed.

**vNICs**

<span>Advanced Filter</span> <span>Export</span> <span>Print</span>				
Name	MAC Address	Desired O... v	Actual Order	Fabric ID
vNIC HANA-Internal	00:25:B5:2A:00:00	1	1	A B
vNIC HANA-Storage	00:25:B5:2B:00:00	2	2	B A
vNIC HANA-AppServer	00:25:B5:2A:00:01	3	3	A B
vNIC HANA-Client	00:25:B5:2B:00:01	4	4	B A
vNIC Mgmt	00:25:B5:2A:00:02	5	5	A B
vNIC HANA-Backup	00:25:B5:2B:00:02	6	6	B A

Delete
Add
Modify

8. Note the MAC Address of the HANA-Internal vNIC is “00:25:B5:2A:00:00”.
9. By comparing MAC Address on the OS and Cisco UCS, eth0 on OS will carry the VLAN for HANA-Internal.
10. Go to network configuration directory and create a configuration for eth0:

```
/etc/sysconfig/network/
vi ifcfg-eth0
BOOTPROTO='static'
BROADCAST=''
ETHTOOL_OPTIONS=''
IPADDR='<<IP subnet for HANA-Internal/subnet mask example:192.168.220.101/24>>'
MTU='9000'
NAME='VIC Ethernet NIC'
NETWORK=''
REMOTE_IPADDR=''
STARTMODE='auto'
```

11. Repeat the steps 11 to 13 for each vNIC interface.
12. Add default gateway.

```
vi etc/sysconfig/network/routes
default 192.168.196.1 - -
```

## DNS

Domain Name Service configuration must be done based on the local requirements.

### Configuration Example

Add DNS IP if it is required to access internet:

```
vi /etc/resolv.conf
nameserver <<IP of DNS Server1>>
nameserver <<IP of DNS Server2>>
search <<Domain_name>>
```

## Hosts file

For scale-out system all nodes should be able to resolve internal network IP address, below is an example of 8 node host file with the entire network defined in the /etc/hosts file.

```
cat /etc/hosts
```

```
127.0.0.1 localhost
# special IPv6 addresses
::1 localhost ipv6-localhost ipv6-loopback
#
## Internal Network
#
192.168.220.211 cishanaso11.ciscolab.local cishanaso11
192.168.220.212 cishanaso12.ciscolab.local cishanaso12
192.168.220.213 cishanaso13.ciscolab.local cishanaso13
192.168.220.214 cishanaso14.ciscolab.local cishanaso14
192.168.220.215 cishanaso15.ciscolab.local cishanaso15
192.168.220.216 cishanaso16.ciscolab.local cishanaso16
192.168.220.217 cishanaso17.ciscolab.local cishanaso17
192.168.220.218 cishanaso18.ciscolab.local cishanaso18
#
## Storage Network
#
192.168.110.211 cishanaso11s.ciscolab.local cishanaso11s
192.168.110.212 cishanaso12s.ciscolab.local cishanaso12s
192.168.110.213 cishanaso13s.ciscolab.local cishanaso13s
192.168.110.214 cishanaso14s.ciscolab.local cishanaso14s
192.168.110.215 cishanaso15s.ciscolab.local cishanaso15s
192.168.110.216 cishanaso16s.ciscolab.local cishanaso16s
192.168.110.217 cishanaso17s.ciscolab.local cishanaso17s
192.168.110.218 cishanaso18s.ciscolab.local cishanaso18s
#
## Client Network
#
192.168.222.211 cishanaso11c.ciscolab.local cishanaso11c
192.168.222.212 cishanaso12c.ciscolab.local cishanaso12c
192.168.222.213 cishanaso13c.ciscolab.local cishanaso13c
192.168.222.214 cishanaso14c.ciscolab.local cishanaso14c
192.168.222.215 cishanaso15c.ciscolab.local cishanaso15c
192.168.222.216 cishanaso16c.ciscolab.local cishanaso16c
192.168.222.217 cishanaso17c.ciscolab.local cishanaso17c
192.168.222.218 cishanaso18c.ciscolab.local cishanaso18c
#
## AppServer Network
#
192.168.223.211 cishanaso11a.ciscolab.local cishanaso11a
192.168.223.212 cishanaso12a.ciscolab.local cishanaso12a
192.168.223.213 cishanaso13a.ciscolab.local cishanaso13a
192.168.223.214 cishanaso14a.ciscolab.local cishanaso14a
192.168.223.215 cishanaso15a.ciscolab.local cishanaso15a
192.168.223.216 cishanaso16a.ciscolab.local cishanaso16a
192.168.223.217 cishanaso17a.ciscolab.local cishanaso17a
192.168.223.218 cishanaso18a.ciscolab.local cishanaso18a
#
## Management Network
```

```

#
192.168.196.211 cishanaso11m.ciscolab.local cishanaso11m
192.168.196.212 cishanaso12m.ciscolab.local cishanaso12m
192.168.196.213 cishanaso13m.ciscolab.local cishanaso13m
192.168.196.214 cishanaso14m.ciscolab.local cishanaso14m
192.168.196.215 cishanaso15m.ciscolab.local cishanaso15m
192.168.196.216 cishanaso16m.ciscolab.local cishanaso16m
192.168.196.217 cishanaso17m.ciscolab.local cishanaso17m
192.168.196.218 cishanaso18m.ciscolab.local cishanaso18m
#
## Backup Network
#
192.168.221.211 cishanaso11b.ciscolab.local cishanaso11b
192.168.221.212 cishanaso12b.ciscolab.local cishanaso12b
192.168.221.213 cishanaso13b.ciscolab.local cishanaso13b
192.168.221.214 cishanaso14b.ciscolab.local cishanaso14b
192.168.221.215 cishanaso15b.ciscolab.local cishanaso15b
192.168.221.216 cishanaso16b.ciscolab.local cishanaso16b
192.168.221.217 cishanaso17b.ciscolab.local cishanaso17b
192.168.221.218 cishanaso18b.ciscolab.local cishanaso18b
#
## DataSource Network
#
192.168.224.211 cishanaso11d.ciscolab.local cishanaso11d
192.168.224.212 cishanaso12d.ciscolab.local cishanaso12d
192.168.224.213 cishanaso13d.ciscolab.local cishanaso13d
192.168.224.214 cishanaso14d.ciscolab.local cishanaso14d
192.168.224.215 cishanaso15d.ciscolab.local cishanaso15d
192.168.224.216 cishanaso16d.ciscolab.local cishanaso16d
192.168.224.217 cishanaso17d.ciscolab.local cishanaso17d
192.168.224.218 cishanaso18d.ciscolab.local cishanaso18d
## Replication Network
#
192.168.225.211 cishanaso11r.ciscolab.local cishanaso11r
192.168.225.212 cishanaso12r.ciscolab.local cishanaso12r
192.168.225.213 cishanaso13r.ciscolab.local cishanaso13r
192.168.225.214 cishanaso14r.ciscolab.local cishanaso14r
192.168.225.215 cishanaso15r.ciscolab.local cishanaso15r
192.168.225.216 cishanaso16r.ciscolab.local cishanaso16r
192.168.225.217 cishanaso17r.ciscolab.local cishanaso17r
192.168.225.218 cishanaso18r.ciscolab.local cishanaso18r
#
## IPMI External Address
#
192.168.196.181 cishanaso11e-ipmi
192.168.196.182 cishanaso12e-ipmi
192.168.196.183 cishanaso13e-ipmi
192.168.196.184 cishanaso14e-ipmi
192.168.196.185 cishanaso15e-ipmi
192.168.196.186 cishanaso16e-ipmi
192.168.196.187 cishanaso17e-ipmi
192.168.196.188 cishanaso18e-ipmi
#
## NFS-IPMI Inband Address
#
192.168.197.161 cishanaso11-ipmi
192.168.197.162 cishanaso12-ipmi
192.168.197.163 cishanaso13-ipmi
192.168.197.164 cishanaso14-ipmi
192.168.197.165 cishanaso15-ipmi
192.168.197.166 cishanaso16-ipmi
192.168.197.167 cishanaso17-ipmi
192.168.197.168 cishanaso18-ipmi
#
##MapR Storage
#
192.168.110.101 mapr11s.ciscolab.local mapr11s
192.168.110.102 mapr12s.ciscolab.local mapr12s
192.168.110.103 mapr13s.ciscolab.local mapr13s
192.168.110.104 mapr14s.ciscolab.local mapr14s
#
## MapR Storage Virtual IP

```

```
#
192.168.110.71 maprvip31
192.168.110.72 maprvip32
192.168.110.73 maprvip33
192.168.110.74 maprvip34
192.168.110.75 maprvip35
192.168.110.76 maprvip36
192.168.110.77 maprvip37
192.168.110.78 maprvip38
```



To get the IP address assigned to the Cisco UCS service profile for Inband Management, go to Cisco UCS Manager, click the LAN tab in the navigation pane, select Pools > root > Sub-Organization > HANA > IP Pools > IP Pools HANA-Servers. In the right pane click the IP Address tab that shows the IP address and assigned Service Profiles.

## SUSE Linux Enterprise Server for SAP Application 12 System Update and OS Customization for HANA Servers

To updated and customize the SLES 12 SP 2 System for HANA Servers, complete the following steps:

1. Register SUSE Linux Enterprise installations with the SUSE Customer Center:

```
SUSEConnect -r <<Registration Code>> -e <<email address>>
```

2. Execute the below command to update the SLES4SAP 12 SP 2 to latest patch level:

```
zypper update
```

3. Follow the on-screen instruction to complete the update process.
4. Disable transparent hugepages, Configure C-States for lower latency in Linux, Auto NUMA settings.
5. Modify `/etc/default/grub` search for the line starting with "GRUB\_CMDLINE\_LINUX\_DEFAULT" and append to this line:

```
transparent_hugepage=never intel_idle.max_cstate=1 processor.max_cstate=1
numa_balancing=disabled
```

6. Save your changes and run:

```
grub2-mkconfig -o /boot/grub2/grub.cfg
```

7. Add the following line into `/etc/init.d/boot.local`, for Energy Performance Bias EPB

```
cpupower set -b 0
```

8. Append following parameters in `/etc/sysctl.conf`:

```
net.ipv4.tcp_slow_start_after_idle = 0
net.ipv4.conf.all.rp_filter = 0
net.ipv4.ip_local_port_range = 40000 61000
net.ipv4.neigh.default.gc_thresh1 = 256
net.ipv4.neigh.default.gc_thresh2 = 1024
net.ipv4.neigh.default.gc_thresh3 = 4096
net.ipv6.neigh.default.gc_thresh1 = 256
net.ipv6.neigh.default.gc_thresh2 = 1024
net.ipv6.neigh.default.gc_thresh3 = 4096
net.core.rmem_max = 16777216
net.core.wmem_max = 16777216
net.core.rmem_default = 262144
```

```

net.core.wmem_default = 262144
net.core.optmem_max = 16777216
net.core.netdev_max_backlog = 300000
net.ipv4.tcp_rmem = 65536 262144 16777216
net.ipv4.tcp_wmem = 65536 262144 16777216
net.ipv4.tcp_no_metrics_save = 1
net.ipv4.tcp_moderate_rcvbuf = 1
net.ipv4.tcp_window_scaling = 1
net.ipv4.tcp_timestamps = 1
net.ipv4.tcp_sack = 1
sunrpc.tcp_slot_table_entries = 128
sunrpc.tcp_max_slot_table_entries = 128
net.ipv4.tcp_slow_start_after_idle = 0

```

9. Add the following line into `/etc/modprobe.d/sunrpc-local.conf`, create the file, if it does not exist:

```

options sunrpc tcp_slot_table_entries=128
options sunrpc tcp_max_slot_table_entries=128

```

10. Activate tuned:

```
saptune daemon start
```

11. Enable tuned profile:

```
saptune solution apply HANA
```

12. Reboot the OS by issuing `reboot` command

## Install Cisco eNIC Driver

To download the Cisco UCS Drivers ISO bundle, which contains most of the Cisco UCS Virtual Interface Card drivers, complete the following steps:

1. In a web browser, navigate to <https://www.cisco.com>.
2. Under Support, click All Downloads.
3. In the product selector, click Products, then click Server - Unified Computing.
4. If prompted, enter your Cisco.com username and password to log in.



You must be signed in to download Cisco Unified Computing System (UCS) drivers.

5. Cisco UCS drivers are available for both Cisco UCS B-Series Blade Server Software and Cisco UCS C-Series Rack-Mount UCS-Managed Server Software.
6. Click UCS B-Series Blade Server Software.
7. Click Cisco Unified Computing System (UCS) Drivers.



The latest release version is selected by default. This document is built on Version 3.2(2a).

8. Click 3.2(2a) Version.
9. Download ISO image of Cisco Unified Computing System (UCS) Drivers.



10. Choose ISO image of UCS-related linux drivers only and click Download and follow the prompts to complete your driver download.
11. After the download is complete browse to \ucs-bxxx-drivers-linux.3.2.2a\Network\Cisco\VIC\SLES\SLES12.2 and copy cisco-enic-kmp-default-2.3.0.30\_k3.12.49\_11-0.x86\_64.rpm to each server
12. ssh to the Server on the Management IP as root.
13. Update the enic driver with the following command;

```
rpm -Uvh /tmp/ cisco-enic-usnic-kmp-default-3.0.44.553.545.8_k4.4.21_69-1.x86_64.rpm
```

14. Update the enic driver on all the HANA Servers.

## Network Time

It is important that the time on all components used for SAP HANA is in sync. The configuration of NTP is important and to be performed on all systems.

1. Configure NTP by adding at least one NTP server to the NTP config file /etc/ntp.conf:

```
vi /etc/ntp.conf
server <NTP-SERVER IP>
fudge <NTP-SERVER IP> stratum 10
keys /etc/ntp.keys
trustedkey 1
```

## SSH Keys

The SSH Keys must be exchanged between all nodes in a SAP HANA Scale-Out system for user 'root' and user <SID>adm.

1. Generate the rsa public key by executing the command:

```
ssh-keygen -b 2048
```

2. The SSH Keys must be exchanged between all nodes in a SAP HANA Scale-Out system for user 'root' and user.
3. Exchange the rsa public key by executing the following command from the first server to rest of the servers in the scale-out system.

```
ssh-copy-id -i /root/.ssh/id_rsa.pub cishanasol2
```

4. Repeat the 1- 3 for all the servers in the SAP HANA system.

## Mount Options

Mount options vary from the default Linux setting for using NFS for SAP HANA data and log volumes. The following is an example of /etc/fstab entry for an eight node SAP HANA Scale-Out system with SID ANA.

```
#HANA Shared Volume
maprvip31:/mapr/mapr600/apps/hana/ANA/shared /hana/shared nfs
nolock,hard,timeo=600 0 0
#HANA Data Volume
maprvip31:/mapr/mapr600/apps/hana/ANA/data001 /hana/data/ANA/mnt00001 nfs
nolock,hard,timeo=600 0 0
maprvip32:/mapr/mapr600/apps/hana/ANA/data002 /hana/data/ANA/mnt00002 nfs
nolock,hard,timeo=600 0 0
```

```

maprvip33:/mapr/mapr600/apps/hana/ANA/data003 /hana/data/ANA/mnt00003 nfs
nolock,hard,timeo=600 0 0
maprvip34:/mapr/mapr600/apps/hana/ANA/data004 /hana/data/ANA/mnt00004 nfs
nolock,hard,timeo=600 0 0
maprvip35:/mapr/mapr600/apps/hana/ANA/data005 /hana/data/ANA/mnt00005 nfs
nolock,hard,timeo=600 0 0
maprvip36:/mapr/mapr600/apps/hana/ANA/data006 /hana/data/ANA/mnt00006 nfs
nolock,hard,timeo=600 0 0
maprvip37:/mapr/mapr600/apps/hana/ANA/data007 /hana/data/ANA/mnt00007 nfs
nolock,hard,timeo=600 0 0
maprvip38:/mapr/mapr600/apps/hana/ANA/data008 /hana/data/ANA/mnt00008 nfs
nolock,hard,timeo=600 0 0
#HANA Log Volume
maprvip38:/mapr/mapr600/apps/hana/ANA/log001 /hana/log/ANA/mnt00001 nfs
nolock,hard,timeo=600 0 0
maprvip37:/mapr/mapr600/apps/hana/ANA/log002 /hana/log/ANA/mnt00002 nfs
nolock,hard,timeo=600 0 0
maprvip36:/mapr/mapr600/apps/hana/ANA/log003 /hana/log/ANA/mnt00003 nfs
nolock,hard,timeo=600 0 0
maprvip35:/mapr/mapr600/apps/hana/ANA/log004 /hana/log/ANA/mnt00004 nfs
nolock,hard,timeo=600 0 0
maprvip34:/mapr/mapr600/apps/hana/ANA/log005 /hana/log/ANA/mnt00005 nfs
nolock,hard,timeo=600 0 0
maprvip33:/mapr/mapr600/apps/hana/ANA/log006 /hana/log/ANA/mnt00006 nfs
nolock,hard,timeo=600 0 0
maprvip32:/mapr/mapr600/apps/hana/ANA/log007 /hana/log/ANA/mnt00007 nfs
nolock,hard,timeo=600 0 0
maprvip31:/mapr/mapr600/apps/hana/ANA/log008 /hana/log/ANA/mnt00008 nfs
nolock,hard,timeo=600 0 0
Create the required directory to mount /hana/shared /hana/data and /hana/log volumes. Mount all the
volumes from /etc/fstab using "mount -a". Check the status of all mounted volumes using "df -h" command.
maprvip31:/mapr/mapr600/apps/hana/ANA/shared 124T 123G 124T 1% /hana/shared
maprvip31:/mapr/mapr600/apps/hana/ANA/data001 124T 123G 124T 1%
/hana/data/ANA/mnt00001
maprvip32:/mapr/mapr600/apps/hana/ANA/data002 124T 123G 124T 1%
/hana/data/ANA/mnt00002
maprvip33:/mapr/mapr600/apps/hana/ANA/data003 124T 123G 124T 1%
/hana/data/ANA/mnt00003
maprvip34:/mapr/mapr600/apps/hana/ANA/data004 124T 123G 124T 1%
/hana/data/ANA/mnt00004
maprvip35:/mapr/mapr600/apps/hana/ANA/data005 124T 123G 124T 1%
/hana/data/ANA/mnt00005
maprvip36:/mapr/mapr600/apps/hana/ANA/data006 124T 123G 124T 1%
/hana/data/ANA/mnt00006
maprvip37:/mapr/mapr600/apps/hana/ANA/data007 124T 123G 124T 1%
/hana/data/ANA/mnt00007
maprvip38:/mapr/mapr600/apps/hana/ANA/data008 124T 123G 124T 1%
/hana/data/ANA/mnt00008
maprvip38:/mapr/mapr600/apps/hana/ANA/log001 124T 123G 124T 1%
/hana/log/ANA/mnt00001
maprvip37:/mapr/mapr600/apps/hana/ANA/log002 124T 123G 124T 1%
/hana/log/ANA/mnt00002
maprvip36:/mapr/mapr600/apps/hana/ANA/log003 124T 123G 124T 1%
/hana/log/ANA/mnt00003
maprvip35:/mapr/mapr600/apps/hana/ANA/log004 124T 123G 124T 1%
/hana/log/ANA/mnt00004
maprvip34:/mapr/mapr600/apps/hana/ANA/log005 124T 123G 124T 1%
/hana/log/ANA/mnt00005
maprvip33:/mapr/mapr600/apps/hana/ANA/log006 124T 123G 124T 1%
/hana/log/ANA/mnt00006
maprvip32:/mapr/mapr600/apps/hana/ANA/log007 124T 123G 124T 1%
/hana/log/ANA/mnt00007
maprvip31:/mapr/mapr600/apps/hana/ANA/log008 124T 123G 124T 1%
/hana/log/ANA/mnt00008

```

**Change the directory permissions BEFORE installing HANA. Use the chown command after the file systems are mounted on each HANA node:**

```

chmod -R 777 /hana/data
chmod -R 777 /hana/log

```

## SAP HANA Installation

---

Please use the official SAP documentation, which describes the installation process with and without the SAP unified installer: [SAP HANA Server Installation Guide](#)



Read the SAP Notes before you start the installation (see, Important SAP Notes). These SAP Notes contain the latest information about the installation, as well as corrections to the installation documentation.

All other SAP installation and administration documentation is available here: <http://service.sap.com/instguides>

### Important SAP Notes

Read the following SAP Notes before you start the installation. These SAP Notes contain the latest information about the installation, as well as corrections to the installation documentation.

The latest SAP Notes can be found at: <https://service.sap.com/notes>.

### SAP HANA IMDB Related Notes

- [SAP Note 1514967](#) - SAP HANA: Central Note
- [SAP Note 1523337](#) - SAP HANA Database: Central Note
- [SAP Note 2000003](#) - FAQ: SAP HANA
- [SAP Note 1730999](#) - Configuration changes in SAP HANA appliance
- [SAP Note 1514966](#) - SAP HANA 1.0: Sizing SAP In-Memory Database
- [SAP Note 1780950](#) - Connection problems due to host name resolution
- [SAP Note 1743225](#) - SAP HANA: Potential failure of connections with scale out nodes
- [SAP Note 1755396](#) - Released DT solutions for SAP HANA with disk replication
- [SAP Note 1890444](#) - HANA system slow due to CPU power save mode
- [SAP Note 1681092](#) - Support for multiple SAP HANA databases on a single SAP HANA appliance
- [SAP Note 1514966](#) - SAP HANA: Sizing SAP HANA Database
- [SAP Note 1637145](#) - SAP BW on HANA: Sizing SAP HANA Database
- [SAP Note 1793345](#) - Sizing for Suite on HANA

### Linux Related Notes

- [SAP Note 2235581](#) - SAP HANA: Supported Operating Systems
- [SAP Note 2009879](#) - SAP HANA Guidelines for RedHat Enterprise Linux (RHEL)
- [SAP Note 2247020](#) - SAP HANA DB: Recommended OS settings for RHEL 6.7
- [SAP Note 2228351](#) - SAP HANA Database SPS 11 revision 110 (or higher) on RHEL 6 or SLES 11
- [SAP Note 1944799](#) - SAP HANA Guidelines for SLES Operating System

- [SAP Note 2205917](#) - SAP HANA DB: Recommended OS settings for SLES 12 / SLES for SAP Applications 12
- [SAP Note 1731000](#) - Non-recommended configuration changes
- [SAP Note 1557506](#) - Linux paging improvements
- [SAP Note 1740136](#) - SAP HANA: wrong mount option may lead to corrupt persistency
- [SAP Note 1829651](#) - Time zone settings in SAP HANA scale out landscapes

## SAP Application Related Notes

- [SAP Note 1658845](#) - SAP HANA DB hardware check
- [SAP Note 1637145](#) - SAP BW on SAP HANA: Sizing SAP In-Memory Database
- [SAP Note 1661202](#) - Support for multiple applications on SAP HANA
- [SAP Note 1681092](#) - Support for multiple SAP HANA databases one HANA aka Multi SID
- [SAP Note 1577128](#) - Supported clients for SAP HANA 1.0
- [SAP Note 1808450](#) - Homogenous system landscape for on BW-HANA
- [SAP Note 1976729](#) - Application Component Hierarchy for SAP HANA
- [SAP Note 1927949](#) - Standard Behavior for SAP Logon Tickets
- [SAP Note 1577128](#) - Supported clients for SAP HANA
- [SAP Note 2186744](#) - FAQ: SAP HANA Parameters
- [SAP Note 2267798](#) - Configuration of the SAP HANA Database during Installation Using hdbparam
- [SAP Note 2156526](#) - Parameter constraint validation on section indices does not work correctly with hdbparam
- [SAP Note 2399079](#) - Elimination of hdbparam in HANA 2

## Third Party Software

- [SAP Note 1730928](#) - Using external software in a SAP HANA appliance
- [SAP Note 1730929](#) - Using external tools in an SAP HANA appliance
- [SAP Note 1730930](#) - Using antivirus software in an SAP HANA appliance
- [SAP Note 1730932](#) - Using backup tools with Backint for SAP HANA

## SAP HANA Virtualization

- [SAP Note 1788665](#) - SAP HANA running on VMware vSphere VMs

## High Availability (HA) Configuration for Scale-Out

For HANA Scale-Out, the ha\_provider python class supports the STONITH functionality.

STONITH = Shoot the Other Node In The Head. With this python class, we are able to reboot the failing node to prevent a split brain and thus an inconsistency of the database. Since we use NFSv3, we must implement the STONITH functionality to prevent the database from a corruption because of multiple access to mounted file systems. If a HANA node is failed over to another node, the failed node will be rebooted from the master name server. This eliminates the risk of multiple accesses to the same file systems.

## High Availability Configuration

The used version of the ucs\_ha\_class.py must be at least 1.1

```
vi ucs_ha_class.py
"""
Function Class to call the reset program to kill the failed host and remove NFS locks for the SAP
HANA HA
Class Name ucs_ha_class
Class Path /usr/sap/<SID>/HDB<ID>/exe/python_support/hdb_ha
Provider Cisco Systems Inc.
Version 1.1 (apiVersion=2 and hdb_ha.client import sudowers)
"""
from hdb_ha.client import StorageConnectorClient
import os
class ucs_ha_class(StorageConnectorClient):
    apiVersion = 2
    def __init__(self, *args, **kwargs):
        super(ucs_ha_class, self).__init__(*args, **kwargs)
    def stonith(self, hostname):
        os.system ("/bin/logger STONITH HANA Node:" + hostname)
        os.system ("/hana/shared/HA/ucs_ipmi_reset.sh " + hostname)
        return 0
    def about(self):
        ver={"provider_company":"Cisco",
            "provider_name" : "ucs_ha_class",
            "provider_version":"1.0",
            "api_version" :2}
        self.tracer.debug('about: %s'+str(ver))
        print '>> ha about',ver
        return ver
    @staticmethod
    def sudoers():
        return """"ALL=NOPASSWD: /bin/mount, /bin/umount, /bin/logger""""
    def attach(self,storages):
        return 0
    def detach(self, storages):
        return 0
    def info(self, paths):
        pass
```

Prepare the script to match the Cisco UCS Manager configured ipmi username and password. Default is ipmi-user sapadm and ipmi-user-password cisco.

```
vi ucs_ipmi_reset.sh
#!/bin/bash
# Cisco Systems Inc.
# SAP HANA High Availability
# Version NFS UCS v01
# changelog: 02/18/2016
if [ -z $1 ]
then
echo "please add the hostname to reset to the command line"
exit 1
fi
# Trim the domain name off of the hostname
host=`echo "$1" | awk -F'.' '{print $1}'`
PASSWD=cisco
USER=sapadm
echo $host-ipmi
system_down='Chassis Power is off'
system_up='Chassis Power is on'
power_down='power off'
power_up='power on'
power_status='power status'
#
# Shut down the server via ipmitool power off
#
/bin/logger `whoami` " Resetting the HANA Node $host because of an Nameserver reset command"
#Power Off
rc2=`/usr/bin/ipmitool -I lanplus -H $host-ipmi -U $USER -P $PASSWD $power_down`
```

```

sleep 20
#Status
rc3=`/usr/bin/ipmitool -I lanplus -H $host-ipmi -U $USER -P $PASSWD $power_status`
#Chassis Power is still on
if [ "$rc3" = "$system_down" ]
then
/bin/logger `whoami` " HANA Node $host switched from ON to OFF "
else
#Power Off again
/bin/logger `whoami` " HANA Node $host still online second try to shutdown... "
rc2=`/usr/bin/ipmitool -I lanplus -H $host-ipmi -U $USER -P $PASSWD $power_down`
sleep 20
#Status
rc3=`/usr/bin/ipmitool -I lanplus -H $host-ipmi -U $USER -P $PASSWD $power_status`
#Chassis Power is still on
if [ "$rc3" = "$system_down" ]
then
/bin/logger `whoami` " HANA Node $host switched from ON to OFF 2nd try"
else
/bin/logger `whoami` " Resetting the HANA Node $host failed "
exit 1
fi
fi
#Chassis Power is down and the server can be swiched back on
#
#The NFS locks are released
#We will start the server now to bring it back as standby node
#Chassis Power is off
power="off"
/bin/logger `whoami` " HANA Node $host will stay offline for 10 seconds..... "
sleep 10
/bin/logger `whoami` " Switching HANA Node $host back ON "
rc2=`/usr/bin/ipmitool -I lanplus -H $host-ipmi -U $USER -P $PASSWD $power_up`
sleep 20
#Status
rc3=`/usr/bin/ipmitool -I lanplus -H $host-ipmi -U $USER -P $PASSWD $power_status`
#Chassis Power is off
if [ "$rc3" = "$system_up" ]
then
/bin/logger `whoami` " HANA Node $host reset done, system is booting"
power="on"
exit 0
else
/bin/logger `whoami` " Switching HANA Node $host back ON failed first time..."
/bin/logger `whoami` " Switching HANA Node $host back ON second time..."
rc2=`/usr/bin/ipmitool -I lanplus -H $host-ipmi -U $USER -P $PASSWD $power_up`
sleep 20
rc3=`/usr/bin/ipmitool -I lanplus -H $host-ipmi -U $USER -P $PASSWD $power_status`
if [ "$rc3" = "$system_up" ]
then
/bin/logger `whoami` " HANA Node $host reset done, system is booting"
power="on"
exit 0
else
/bin/logger `whoami` " Resetting the HANA Node $host failed "
exit 1
fi
fi
#
# Server is power on and should boot - our work is done
#

```

Copy the HA scripts to the shared HA directory under /hana/shared/<SID>/HA (HANA nameserver is responsible to reset the failed node)

```

ssh cishana01
mkdir /hana/shared/HA
chown anaadm:sapsys /hana/shared/HA
scp ucs_ipmi_reset.sh /hana/shared/HA/
scp ucs_ha_class.py /hana/shared/HA/
chown anaadm:sapsys /hana/shared/HA/*

```

## Enable the SAP HANA Storage Connector API

The SAP Storage Connector API provides a way to call a user procedure whenever the SAP HANA Nameserver triggers a node failover. The API requires the files mentioned above.

The procedure is executed on the master nameserver.

To activate the procedure in case of a node failover, the global.ini file in:

```
<HANA installdirectory>/<SID>/global/hdb/custom/config/
must be edited and the following entry must be added:
[Storage]
ha_provider = ucs_ha_class
ha_provider_path = /hana/shared/HA
cd /hana/shared/<SID>/global/hdb/custom/config
vi global.ini
[communication]
internal_network = 192.168.220/24
listeninterface = .internal
[internal_hostname_resolution]
192.168.220.211 = cishanaso11
192.168.220.212 = cishanaso12
192.168.220.213 = cishanaso13
192.168.220.218 = cishanaso18
192.168.220.214 = cishanaso14
192.168.220.216 = cishanaso16
192.168.220.215 = cishanaso15
192.168.220.217 = cishanaso17
[persistence]
basepath_datavolumes = /hana/data/ANA
basepath_logvolumes = /hana/log/ANA
[storage]
ha_provider = ucs_ha_class
ha_provider_path = /hana/shared/HA
[trace]
ha_ucs_ha_class = info
```

Modify the /etc/sudoers file and append the below line on all the nodes. By adding the line <sid>adm account can execute commands mentioned without password.

```
cishana01:/ # vi /etc/sudoers
<sid>adm ALL=NOPASSWD: /bin/mount, /bin/umount, /bin/logger, /sbin/multipath,
/sbin/multipathd, /usr/bin/sg_persist, /etc/init.d/multipathd, /bin/kill,
/usr/bin/lsof, /sbin/vgchange, /sbin/vgscan
```

To activate the change, please restart the SAP HANA DB.

## Test the IPMI Connectivity

Test the ipmi connectivity on ALL nodes:

```
cishana01:~ # ipmitool -I lanplus -H cishana01-ipmi -U sapadm -P cisco power
status
Chassis Power is on
```



Make sure that all the nodes are responding to the ipmitool command and the IP address for the ipmi network match in the /etc/hosts file of all the servers.

## SAP HANA Parameters for Scale-Out

The default communication path among the SAP HANA nodes uses the access network. To optimize the internode traffic, the MTU value needs to be 9000, which is already set in the storage VLAN. As part of setting up a distributed system, you need to configure the network parameters. Make sure that you do this before you add hosts because one server needs to be available so that you can connect to the SAP HANA Studio. For more information, refer to the SAP HANA Administration Guide.

```
hdbnsutil -reconfig --hostnameResolution=internal
```

After the change, all internal SAP HANA traffic goes over the server. Make sure to adjust `internal_hostname_resolution` in the `/hana/shared/<SID>/global/hdb/custom/config/global.ini`

```
[communication]
internal_network = 192.168.220/24
listeninterface = .internal
[internal_hostname_resolution]
192.168.220.211 = cishanaso11
192.168.220.212 = cishanaso12
192.168.220.213 = cishanaso13
192.168.220.218 = cishanaso18
192.168.220.214 = cishanaso14
192.168.220.216 = cishanaso16
192.168.220.215 = cishanaso15
192.168.220.217 = cishanaso17
[persistence]
basepath_datavolumes = /hana/data/ANA
basepath_logvolumes = /hana/log/ANA
[storage]
ha_provider = ucs_ha_class
ha_provider_path = /hana/shared/HA
[trace]
ha_ucs_ha_class = info
```

## SAP HANA Hardware Configuration Check Tool Parameter

Use the following parameter setting in the HWCCT in order to meeting the SAP HANA KPI for the Filesystem Test:

```
{
  "id":2,
  "package": "FilesystemTest",
  "test_timeout": 0,
  "config": {"mount":{
    "cishanaso11":["/hana/log/ANA/mnt00001/"],
    "cishanaso12":["/hana/log/ANA/mnt00002/"],
    "cishanaso13":["/hana/log/ANA/mnt00003/"],
    "cishanaso14":["/hana/log/ANA/mnt00004/"],
    "cishanaso15":["/hana/log/ANA/mnt00005/"],
    "cishanaso16":["/hana/log/ANA/mnt00006/"],
    "cishanaso17":["/hana/log/ANA/mnt00007/"],
    "cishanaso18":["/hana/log/ANA/mnt00008/"]
  }},
  "parameter":{"max_parallel_io_requests":"128",
    "async_read_submit":"on",
    "async_write_submit_active": "on",
    "async_write_submit_blocks":"all"},
  "duration":"long"
},
"class": "LogVolumeIO"
},
{
  "id":3,
  "package": "FilesystemTest",
  "test_timeout": 0,
  "config": {"mount":{
    "cishanaso11":["/hana/data/ANA/mnt00001/"],
    "cishanaso12":["/hana/data/ANA/mnt00002/"],
    "cishanaso13":["/hana/data/ANA/mnt00003/"],
    "cishanaso14":["/hana/data/ANA/mnt00004/"],
    "cishanaso15":["/hana/data/ANA/mnt00005/"],
    "cishanaso16":["/hana/data/ANA/mnt00006/"],
    "cishanaso17":["/hana/data/ANA/mnt00007/"],
    "cishanaso18":["/hana/data/ANA/mnt00008/"]
  }},
  "parameter":{"max_parallel_io_requests":"128",
    "async_read_submit":"on",
    "async_write_submit_active": "on",
```



```
"async_write_submit_blocks":"all"},
"duration":"long"
},
"class": "DataVolumeIO"
}
]
}
```

hdbparam is used to configure the HANA database with parameter vector given for optimal storage performance. hdbparam used for HANA 1.0.

Run these commands for all four parameters:

```
"max_parallel_io_requests":"128",
"async_read_submit":"on",
"async_write_submit_active": "on",
"async_write_submit_blocks":"all"},
```

With User <sid>adm:

```
hdbparam --paramset fileio [DATA].max_parallel_io_requests=128
hdbparam --paramset fileio [DATA].async_read_submit=on
hdbparam --paramset fileio [DATA].async_write_submit_active=on
hdbparam --paramset fileio [DATA].async_write_submit_blocks=all
hdbparam --paramset fileio [LOG].max_parallel_io_requests=128
hdbparam --paramset fileio [LOG].async_read_submit=on
hdbparam --paramset fileio [LOG].async_write_submit_active=on
hdbparam --paramset fileio [LOG].async_write_submit_blocks=all
```

For SAP HANA 2.0 global.ini is used to set the parameter vector for optimal storage performance.

Add the following parameters in the /hana/shared/<SID>/global/hdb/custom/config/global.ini:

```
[fileio]
max_parallel_io_requests = 128
async_read_submit = on
async_write_submit_active = on
async_write_submit_blocks = all
```

Restart the HANA Database for configuration to take effect.

Stop the HANA Database with the following command:

```
/usr/sap/hostctrl/exe/sapcontrol -nr 00 -function StopSystem HDB
```

Start the HANA Database with the following command:

```
/usr/sap/hostctrl/exe/sapcontrol -nr 00 -function StartSystem HDB
```

Check the HANA Database Status with the following command:

```
/usr/sap/hostctrl/exe/sapcontrol -nr 00 -function GetSystemInstanceList
GetSystemInstanceList
OK
hostname, instanceNr, httpPort, httpsPort, startPriority, features, dispstatus
cishanaso16, 0, 50013, 50014, 0.3, HDB|HDB_WORKER, GREEN
cishanaso15, 0, 50013, 50014, 0.3, HDB|HDB_WORKER, GREEN
cishanaso18, 0, 50013, 50014, 0.3, HDB|HDB_STANDBY, GREEN
cishanaso11, 0, 50013, 50014, 0.3, HDB|HDB_WORKER, GREEN
cishanaso13, 0, 50013, 50014, 0.3, HDB|HDB_WORKER, GREEN
cishanaso12, 0, 50013, 50014, 0.3, HDB|HDB_WORKER, GREEN
cishanaso17, 0, 50013, 50014, 0.3, HDB|HDB_WORKER, GREEN
```

## About the Authors

---

### **Shailendra Mruthunjaya, Cisco Systems, Inc.**

Shailendra is a Technical Marketing Engineer with Cisco UCS Solutions and Performance Group. Shailendra has over six years of experience with SAP HANA on Cisco UCS platform. Shailendra has designed several SAP landscapes in public and private cloud environment. Currently, his focus is on developing and validating infrastructure best practices for SAP applications on Cisco UCS Servers, Cisco Nexus products and Storage technologies.

### **Matthias Schlarb, Cisco Systems, Inc.**

Matthias is part of the Cisco SAP Competence Center in Walldorf where he conducts workshops with customers and partners. As a Technical Marketing Engineer, he develops best practices for SAP Cloud Infrastructure on Cisco Unified Computing System.

## Acknowledgements

For their support and contribution to the design, validation, and creation of this CVD, we would like to thank:

- Ralf Klahr, Cisco Systems, Inc.
- Ulrich Kleidon, Cisco Systems, Inc.
- Erik Lillestolen, Cisco Systems, Inc.
- Arun Kumar Thiruttani Kalathi, Cisco Systems, Inc.
- Andy Lerner, MapR Technologies, Inc.
- James Sun, MapR Technologies, Inc.