



Cisco Embedded Services 3300 Series Switches Hardware Technical Guide

First Published: 2018-07-19

Last Modified: 2023-02-06

Americas Headquarters

Cisco Systems, Inc.
170 West Tasman Drive
San Jose, CA 95134-1706
USA
<http://www.cisco.com>
Tel: 408 526-4000
800 553-NETS (6387)
Fax: 408 527-0883



CONTENTS

CHAPTER 1

Product Overview 1

- Overview 1
- Audience 2
- General Description 2
- Main Board Layout and Dimensions 3
 - Main Board Without Cooling Plate 4
 - Main Board With Cooling Plate 7
- Expansion Board Layout and Dimensions 8
 - Expansion Board Without Cooling Plate 8
 - Expansion Board With Cooling Plate 11

CHAPTER 2

Interface Connectors 13

- Interface Connectors Overview 13
- Main Board Interface Connectors (I/O and Network Interface) 13
 - ESS-3300 Network Interface Connector (J1) 14
 - ESS-3300 Main Board I/O Connector (J2) 16
- Expansion Board Interface Connectors (I/O and Network Interface) 18
 - ESS-3300 Expansion Board I/O Connector (J1) 18
 - ESS-3300 Expansion Board Network Interface Connector (J2) 21
- Board to Board Connectors 23

CHAPTER 3

Implementation Options 25

- LED Definitions 25
 - Main Board LED Register Bits 27
 - Expansion Board LED Register Bits 29
- Main Module I/O Description 31

PCIe Loopback	32
Main Module Voltage Test Points	32
Mechanical and Environmental Testing	34
Overtemperature Detection	36
Thermal Design Considerations	37
Validating a Thermal Solution	41
Product Specifications	41
Power Requirements	43
Dying Gasp	43
Electrical Power Consumption	43
Power Over Ethernet (PoE)	44
SD Support	45
SFP Support	45
Supported SFP (plus marker) Modules	46
Supported SFP Modules	46
Supported Fast Ethernet SFP Modules	47
<hr/>	
CHAPTER 4	Device Zeroization and Recovery 49
	Device Zeroization 49
	Important Notice about Zeroization 50
	Command Line Interface 51
	Zeroization Trigger 51
	Recovery Procedures 52
<hr/>	
CHAPTER 5	Secure Data Wipe 53
	Enabling Secure Data Wipe 53
<hr/>	
CHAPTER 6	Appendix 55
	Cisco Reference Design Port Map 55
	Web User Interface 56
	Compliance and Safety Information 57
	Restriction of Hazardous Substances (RoHS) 58
	Related Documentation 58
	Communications, Services, and Additional Information 58

[Cisco Bug Search Tool](#) 59
[Documentation Feedback](#) 59



CHAPTER 1

Product Overview

This chapter contains the following sections:

- [Overview, on page 1](#)
- [Audience, on page 2](#)
- [General Description, on page 2](#)
- [Main Board Layout and Dimensions, on page 3](#)
- [Expansion Board Layout and Dimensions, on page 8](#)

Overview

This hardware technical guide provides a product description, specifications, and compliance information for the Cisco Embedded Service 3300 Series Switches.



Note The documentation set for this product strives to use bias-free language. For purposes of this documentation set, bias-free is defined as language that does not imply discrimination based on age, disability, gender, racial identity, ethnic identity, sexual orientation, socioeconomic status, and intersectionality. Exceptions may be present in the documentation due to language that is hardcoded in the user interfaces of the product software, language used based on RFP documentation, or language that is used by a referenced third-party product.

The Cisco ESS 3300 is an embedded Ethernet switch card with a board size of 4.050 in x 3.775 in (102.87mm x 95.89mm). This module *may* fit in an enclosure that was *originally designed* for PC/104 modules with some additional adaptation.

The compact design simplifies integration and offers system integrators the ability to use the Cisco ESS 3300 in a wide variety of applications. The Cisco ESS 3300 consists of a Main Board and an optional Expansion Board. Both the Main Board and the Expansion Board are available with Cisco-designed cooling plates, and are also available without the cooling plates for system integrators who want to design their own custom thermal solutions.

The following table provides the hardware product IDs and brief descriptions for the boards.

SKU	Description	Ports	Thermal Power
ESS-3300-NCP-E	Main Board without a cooling plate.	2 ports of 10 GE fiber, 8 ports of GE copper. 4 of the 8 GE copper ports can also be combo ports.	16 Watts
ESS-3300-CON-E	Main Board conduction cooled	2 ports of 10 GE fiber, 8 ports of GE copper. 4 of the 8 GE copper ports can also be combo ports	16 Watts
ESS-3300-24T-NCP-E	Main Board with a 16p Expansion Board without a cooling plate	2 ports of 10 GE fiber, 24 ports of GE copper 4 of 8 GE ports can be combo ports on mainboard 4 of 16 GE ports can be combo ports on expansion board	24 Watts
ESS-3300-24T-CON-E	Main Board with a 16p Expansion Board conduction cooled	2 ports of 10 GE fiber, 24 ports of GE copper 4 of 8 GE ports can be combo ports on mainboard 4 of 16 GE ports can be combo ports on expansion board	24 Watts



Note Refer to the [Cisco ESS 3300 Product Data Sheet](#) for a complete list of available product IDs.



Note The 24T SKU is a combination of the Main Board together with the 16T Expansion board.

Audience

This guide is for system integrators who are integrating the Cisco ESS 3300 into a custom end product.

General Description

The ESS-3300 is a ruggedized GigE Embedded platform for tactical, outdoor and mobile installations. Some of the key features are:

- PC104 form-factor (mechanical size)
- Main Board – 2 Optical 10G + 8 GE ports (4 combo)
- Expansion Board – 16 GE ports (4 combo)
- Next Generation IE switch feature set

- Software: IOS-XE, Network Essentials and Network Advantage
- Native PoE software visibility
- WEBUI/IND/Cisco Prime support (Available early 2019)
- Industrial temperature: -40°C to +85°C conduction plate temperature
- ARM Quad-Core A53, 1.2GHz
- 4GB DDR4 DRAM memory capacity
- 1.2GB usable eMMC flash
- 3.3V and 5V power input
- Anti-counterfeit chip on both Main and Expansion Boards / Secure Boot
- RTC with customer provided power backup
- External Push Button, that supports the Zeroize feature
- Two alarm inputs and One alarm output
- One SD interface
- One USB 2.0 Host interface for USB Flash Memory Device.
- One USB 2.0 Console Interface.
- One RS-232 Console Interface.

Main Board Layout and Dimensions

The following figure shows the Main Board. The dimensions are 4.050 in x 3.775 in (102.87mm x 95.89mm).

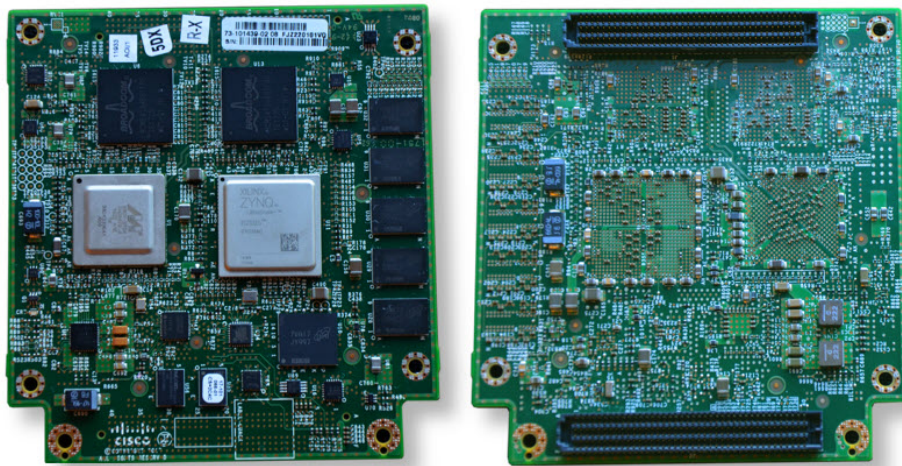

The following figure shows the Expansion Board. The dimensions are 3.55 in x 3.775 in (90.17mm x 95.89mm).

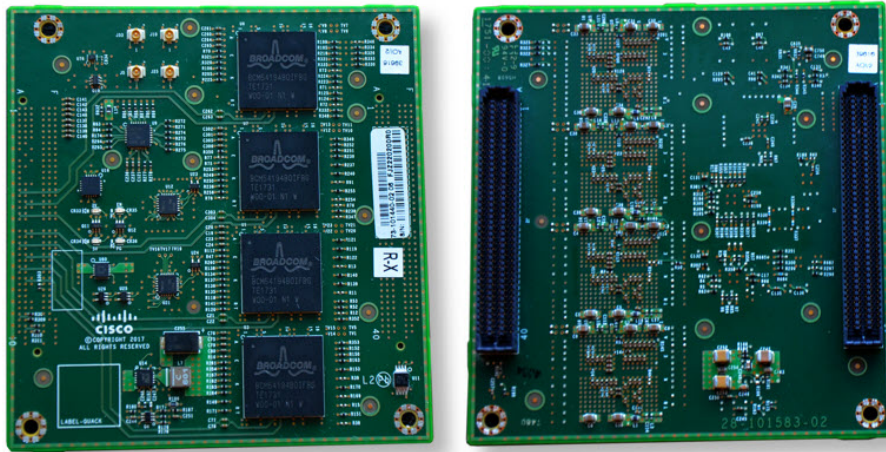

Main Board Without Cooling Plate

The following figures show the layout and dimensions of the Main Board that is not equipped with the Cisco-designed cooling plate (ESS-3300-NCP-E).



Note Dimensions in inches. Tolerances (unless otherwise stated): .XX +/- 0.010, .XXX +/- 0.005

Figure 1: ESS-3300-NCP-E (Main Board Without the Cooling Plate)

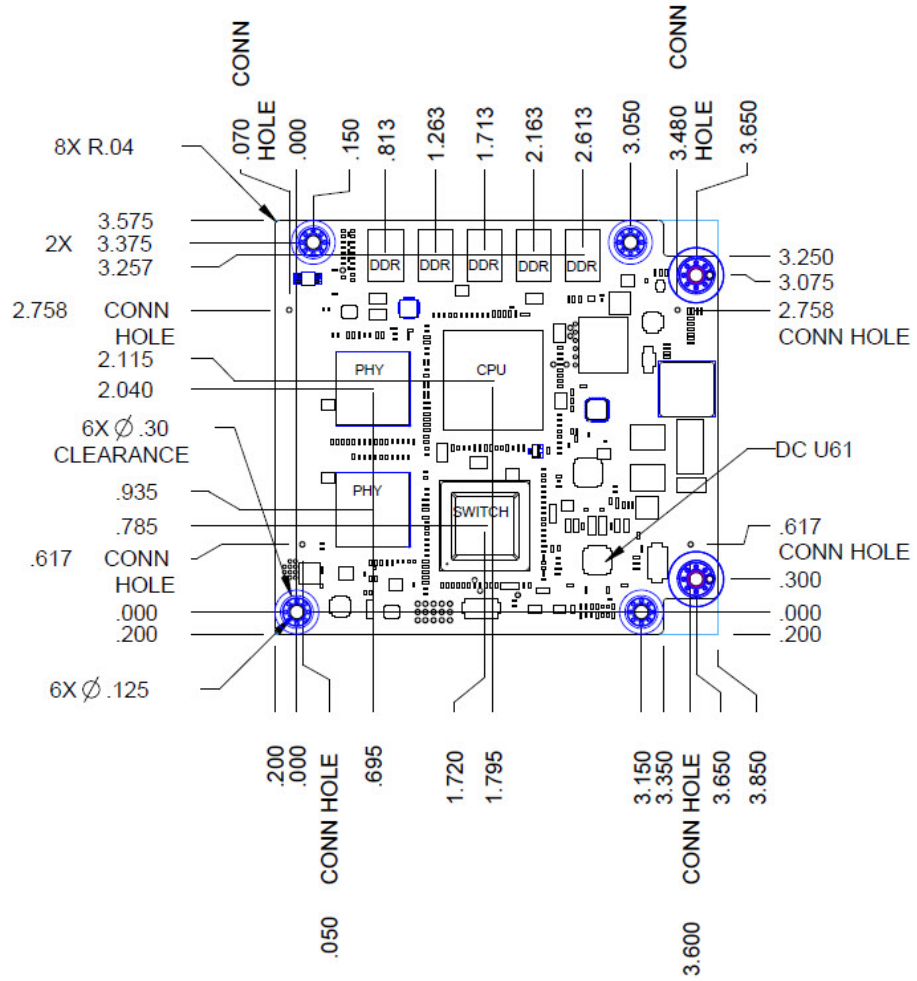

Figure 2: ESS-3300-NCP-E (Main Board Without Cooling Plate)

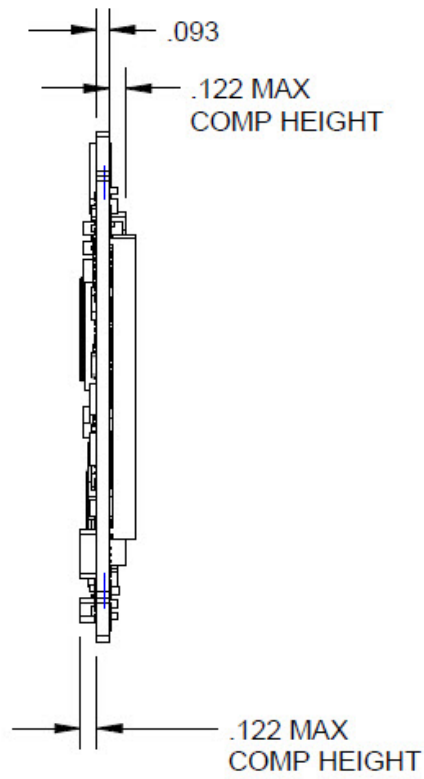
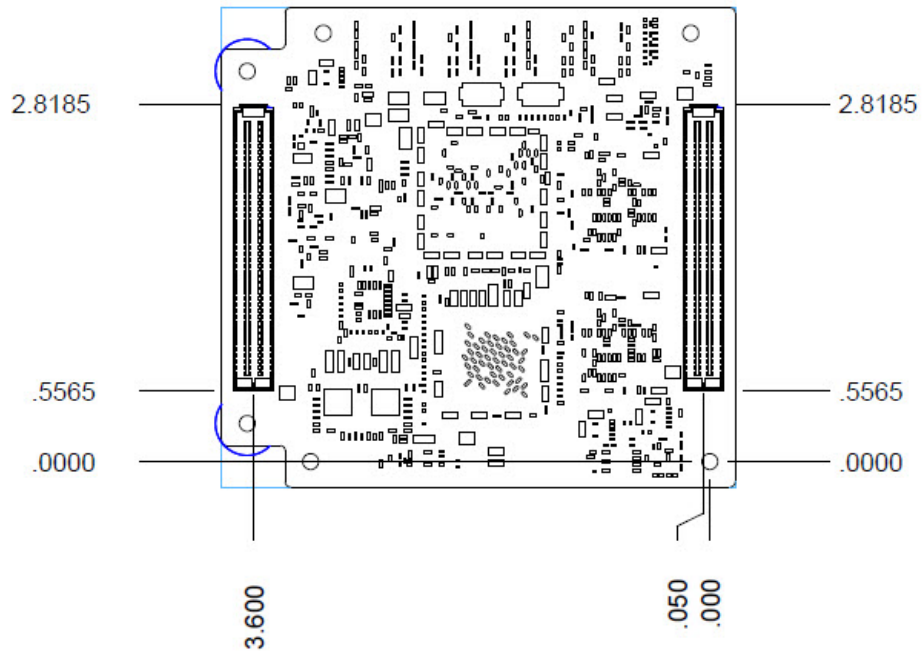

Figure 3: ESS-3300-NCP-E (Main Board Without Cooling Plate)



Main Board With Cooling Plate

The following figures show the layout and dimensions of the Main Board that is equipped with the Cisco-designed cooling plate (ESS-3300-CON-E).



Note Dimensions in inches. Tolerances (unless otherwise stated): .XX +/- 0.010, .XXX +/- 0.005

Figure 4: ESS-3300-CON-E (Main Board with Cooling Plate)

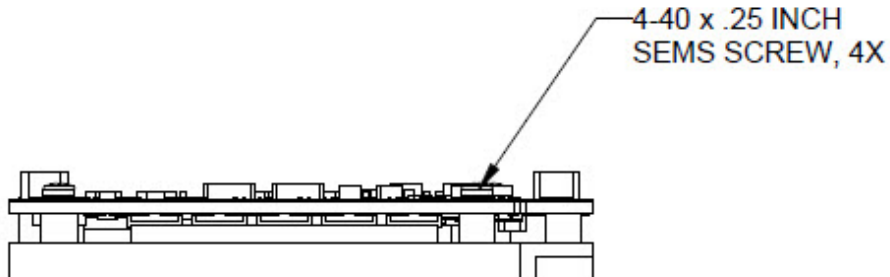

Figure 5: ESS-3300-CON-E (Main Board with Cooling Plate)

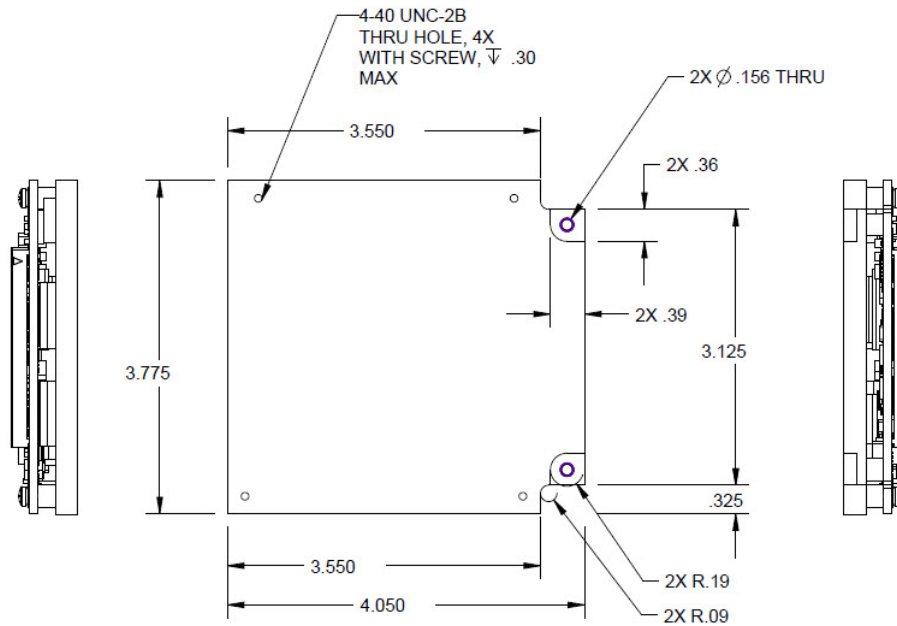
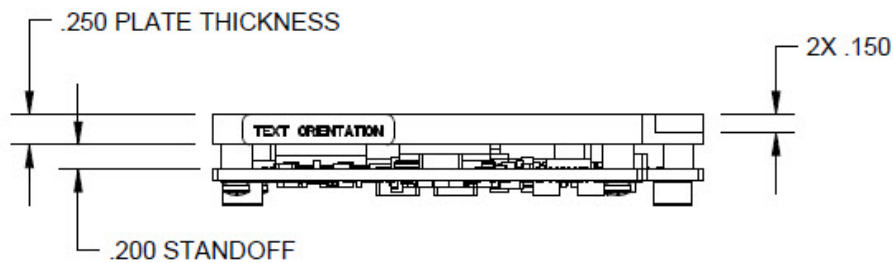

Figure 6: ESS-3300-CON-E (Main Board with Cooling Plate)



Expansion Board Layout and Dimensions

This section shows details of the board layout.

Expansion Board Without Cooling Plate

The following figures show the layout and dimensions of the Expansion Board that is not equipped with the Cisco-designed cooling plate (ESS-3300-24T-NCP-E).



Note Dimensions in inches. Tolerances (unless otherwise stated): .XX +/- 0.010, .XXX +/- 0.005

Figure 7: ESS-3300-24T-NCP-E (Expansion Board Without Cooling Plate)

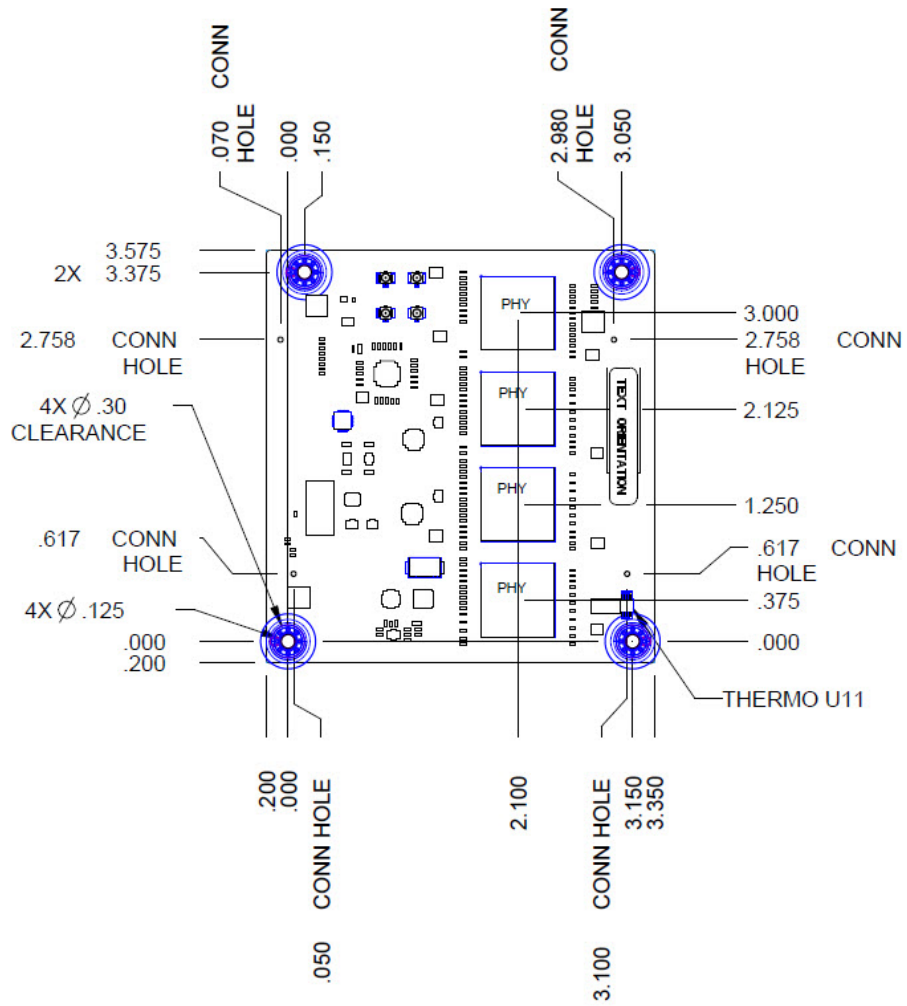

Figure 8: ESS-3300-24T-NCP-E (Expansion Board Without Cooling Plate)

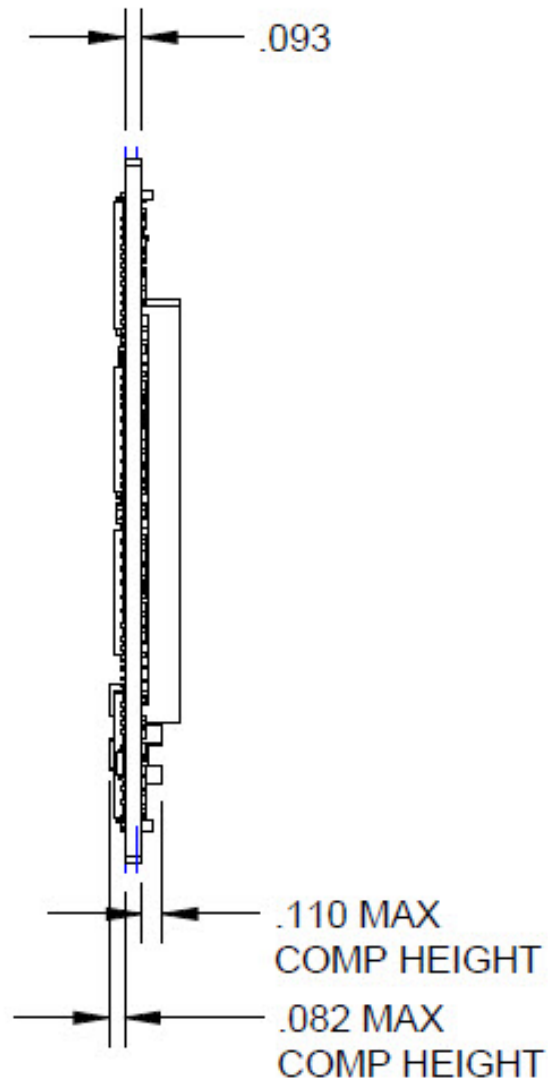
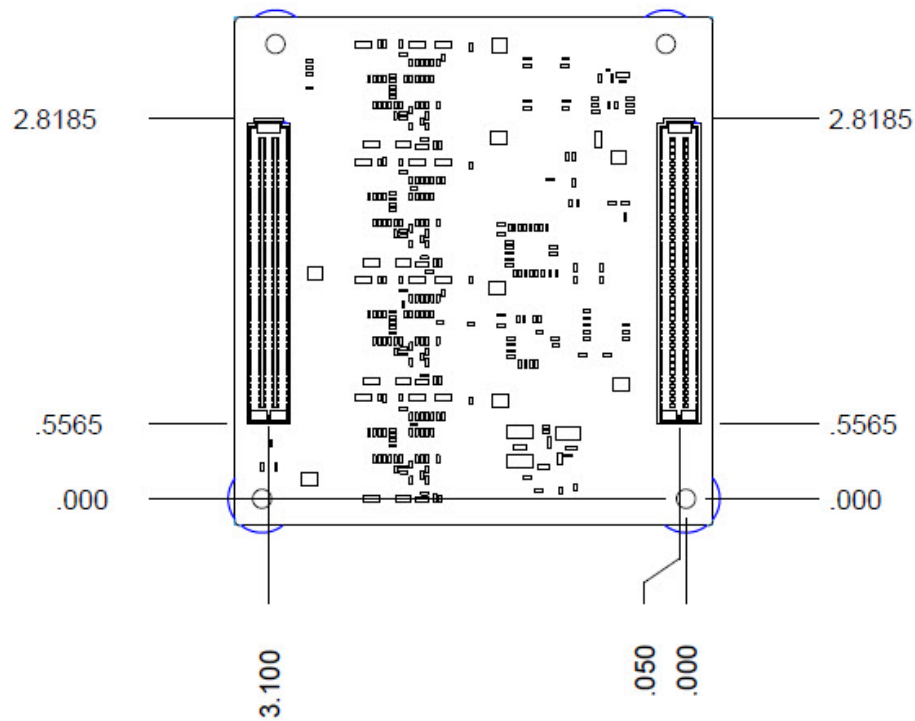

Figure 9: ESS-3300-24T-NCP-E (Expansion Board Without Cooling Plate)



Expansion Board With Cooling Plate

The following figures show the layout and dimensions of the Expansion Board that is equipped with the Cisco-designed cooling plate (ESS-3300-24T-CON-E).



Note Dimensions in inches. Tolerances (unless otherwise stated): .XX +/- 0.010, .XXX +/- 0.005

Figure 10: ESS-3300-24T-CON-E (Expansion Board with Cooling Plate)

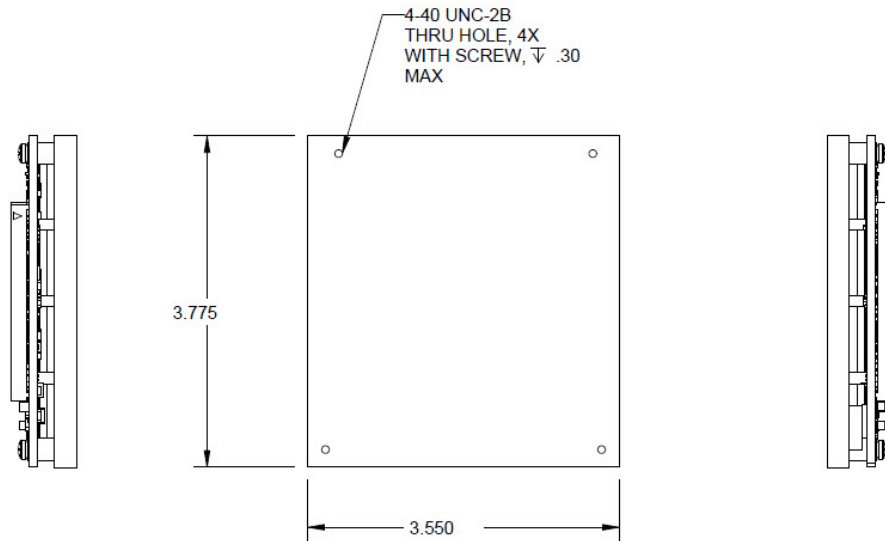

Figure 11: ESS-3300-24T-CON-E (Expansion Board with Cooling Plate)—Bottom and Side View

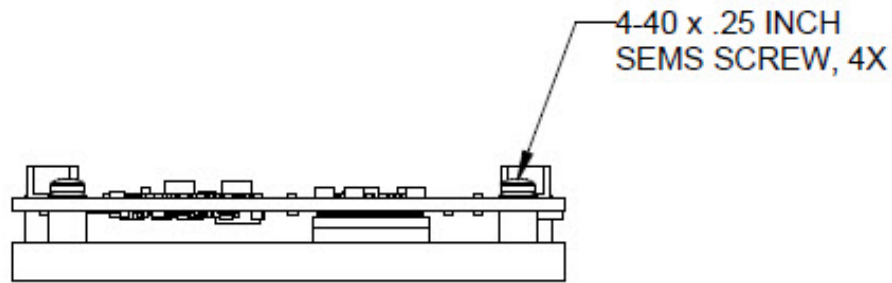
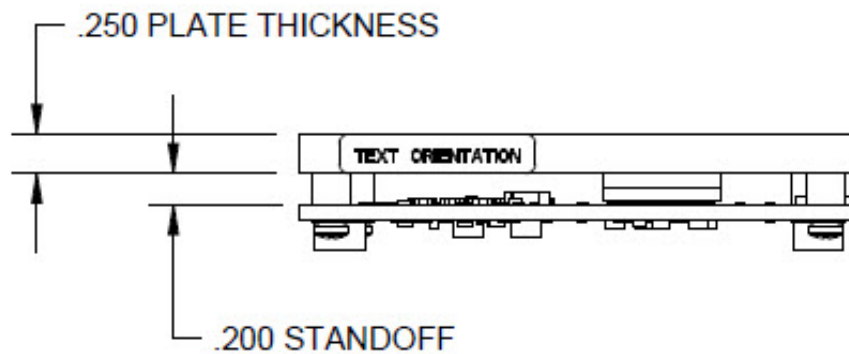

Figure 12: ESS-3300-24T-CON-E (Expansion Board with Cooling Plate)





CHAPTER 2

Interface Connectors

This chapter contains the following sections:

- [Interface Connectors Overview](#), on page 13
- [Main Board Interface Connectors \(I/O and Network Interface\)](#), on page 13
- [Expansion Board Interface Connectors \(I/O and Network Interface\)](#), on page 18
- [Board to Board Connectors](#), on page 23

Interface Connectors Overview

The Main Board and the Expansion Board each have two connectors that provide power and interface connections to external devices and to each other. All of the connectors belong to the SEARAY® Connector Series from SAMTEC. Depending on the mating connector selected by the integrator, the connector series supports a stacking height from 7 mm to 18mm (not all increments are supported).

Main Board Interface Connectors (I/O and Network Interface)

The locations and designations of the two Main Board interface connectors are shown in the following figure.

The Main Board I/O connectors (J1 and J2) are a SAMTEC SEAF-40-05.0-S-06-2-A-K 240-pin connector. See the following figure for the pin numbering convention.

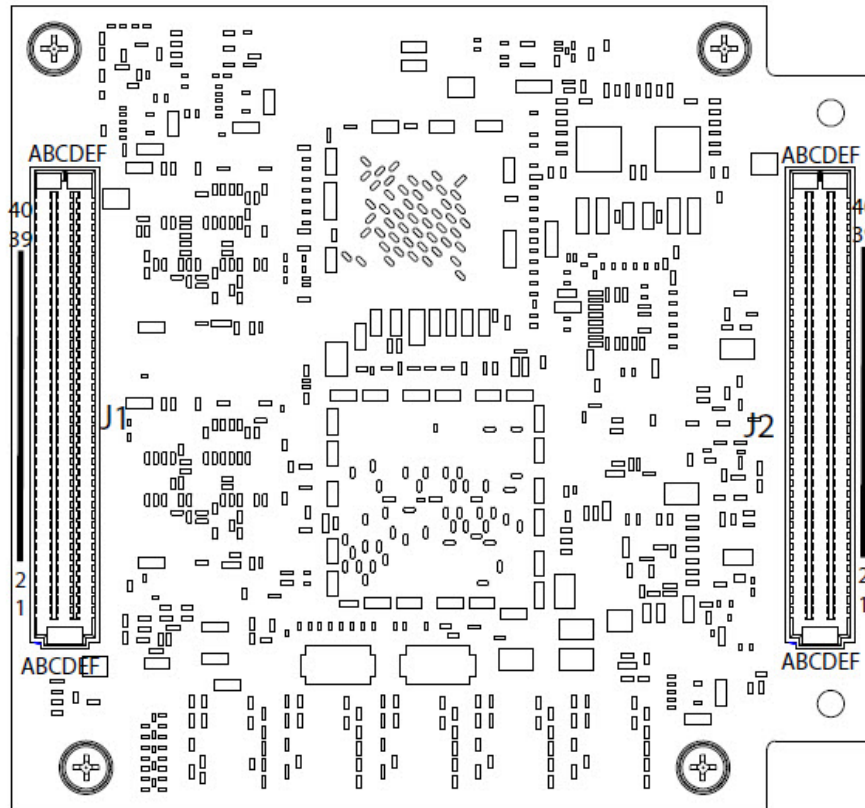

ESS-3300 Network Interface Connector (J1)

Pin #	Row A	Row B	Row C	Row D	Row E	Row F
1	NC	NC	NC	NC	NC	NC
2	NC	NC	NC	NC	NC	NC
3	NC	NC	GND	NC	GND	NC
4	NC	NC	Gi1/9 MDI3 P	GND	Gi1/9 MDI1 P	GND
5	GND	GND	Gi1/9 MDI3 N	Gi1/9 MDI2_P	Gi1/9 MDI1 N	Gi1/9 MDI0 P
6	SFP Gi1/4 SCL	SFP Gi1/3 SCL	GND	Gi1/9 MDI2_N	GND	Gi1/9 MDI0 N
7	GND	GND	Gi1/10 MDI3 P	GND	Gi1/10 MDI1 P	GND
8	SFP Gi1/4 SDA	SFP Gi1/3 SDA	Gi1/10 MDI3 N	Gi1/10 MDI2_P	Gi1/10 MDI1 N	Gi1/10 MDI0 P
9	GND	GND	GND	Gi1/10 MDI2_N	GND	Gi1/10 MDI0 N

Pin #	Row A	Row B	Row C	Row D	Row E	Row F
10	SFP Gi1/4 RXLOS	SFP Gi1/3 RXLOS	Gi1/7 MDI3 P	GND	Gi1/7 MDI1 P	GND
11	SFP Gi1/4 TXFLT	SFP Gi1/3 TXFLT	Gi1/7 MDI3 N	Gi1/7 MDI2_P	Gi1/7 MDI1 N	Gi1/7 MDI0 P
12	SFP Gi1/4 PRES_L	SFP Gi1/3 PRES_L	GND	Gi1/7 MDI2_N	GND	Gi1/7 MDI0 N
13	SFP Gi1/4 TXDIS	SFP Gi1/3 TXDIS	Gi1/8 MDI3 P	GND	Gi1/8 MDI1 P	GND
14	SFP Gi1/4 PWR EN	SFP Gi1/3 PWR EN	Gi1/8 MDI3 N	Gi1/8 MDI2_P	Gi1/8 MDI1 N	Gi1/8 MDI0 P
15	GND	GND	GND	Gi1/8 MDI2_N	GND	Gi1/8 MDI0 N
16	SFP Gi1/6 SCL	SFP Gi1/5 SCL	SFP Gi1/5 TXD P	GND	SFP Gi1/3 TXD P	GND
17	GND	GND	SFP Gi1/5 TXD N	SFP Gi1/6 TXD P	SFP Gi1/3 TXD N	SFP Gi1/4 TXD P
18	SFP Gi1/6 SDA	SFP Gi1/5 SDA	GND	SFP Gi1/6 TXD N	GND	SFP Gi1/4 TXD N
19	GND	GND	SFP Gi1/5 RXD P	GND	SFP Gi1/3 RXD P	GND
20	SFP Gi1/6 RXLOS	SFP Gi1/5 RXLOS	SFP Gi1/5 RXD N	SFP Gi1/6 RXD P	SFP Gi1/3 RXD N	SFP Gi1/4 RXD
21	SFP Gi1/6 TXFLT	SFP Gi1/5 TXFLT	GND	SFP Gi1/6 RXD N	GND	SFP Gi1/4 RXD N
22	SFP Gi1/6 PRES_L	SFP Gi1/5 PRES_L	Gi1/5 MDI3 P	GND	Gi1/5 MDI1 P	GND
23	SFP Gi1/6 TXDIS	SFP Gi1/5 TXDIS	Gi1/5 MDI3 N	Gi1/5 MDI2 P	Gi1/5 MDI1 N	Gi1/5 MDI0 P
24	SFP Gi1/6 PWR EN	SFP Gi1/5 PWR_EN	GND	Gi1/5 MDI2 N	GND	Gi1/5 MDI0 N
25	GND	GND	Gi1/6 MDI3 P	GND	Gi1/6 MDI1 P	GND
26	SFP Te1/2 SCL	SFP Te1/1 SCL	Gi1/6 MDI3 N	Gi1/6 MDI2 P	Gi1/6 MDI1 N	Gi1/6 MDI0 P
27	GND	GND	GND	Gi1/6 MDI2 N	GND	Gi1/6 MDI0 N
28	SFP Te1/2 SDA	SFP Te1/1 SDA	Gi1/3 MDI3 P	GND	Gi1/3 MDI1 P	GND
29	GND	GND	Gi1/3 MDI3 N	Gi1/3 MDI2 P	Gi1/3 MDI1 N	Gi1/3 MDI0 P
30	SFP Te1/2 RXLOS	SFP Te1/1 RXLOS	GND	Gi1/3 MDI2 N	GND	Gi1/3 MDI0 N
31	SFP Te1/2 TXFLT	SFP Te1/1 TXFLT	Gi1/4 MDI3 P	GND	Gi1/4 MDI1 P	GND
32	SFP Te1/2 PRES_L	SFP Te1/1 PRES_L	Gi1/4 MDI3 N	Gi1/4 MDI2 P	Gi1/4 MDI1 N	Gi1/4 MDI0 P
33	SFP Te1/2 TXDIS	SFP Te1/1 TXDIS	GND	Gi1/4 MDI2 N	GND	Gi1/4 MDI0 N
34	SFP Te1/2 PWR EN	SFP Te1/1 PWR EN	GND	GND	GND	GND
35	NC	GND	GND	GND	GND	GND
36	NC	GND	SFP Te1/1 RXD P	GND	SFP Te1/2 RXD P	GND

ESS-3300 Main Board I/O Connector (J2)

Pin #	Row A	Row B	Row C	Row D	Row E	Row F
37	NC	GND	SFP Te1/1 RXD N	GND	SFP Te1/2 RXD N	GND
38	NC	GND	GND	SFP Te1/1 TXD P	GND	SFP Te1/2 TXD P
39	NC	GND	GND	SFP Te1/1 TXD N	GND	SFP Te1/2 TXD N
40	NC	GND	GND	GND	GND	GND

ESS-3300 Main Board I/O Connector (J2)

PIN #	Row A	Row B	Row C	Row D	Row E	Row F
1	P5V	P5V	P5V	P5V	P5V	P5V
2	P5V	P5V	P5V	P5V	P5V	P5V
3	GND	GND	GND	GND	GND	GND
4	GND	GND	GND	GND	GND	GND
5	P3_3V	P3_3V	P3_3V	P3_3V	P3_3V	P3_3V_RTC
6	GND	GND	GND	P5V_USB	GND	GND
7	SDIO DATA[0]	GND	SDIO DIR CMD	GND	USB_CONSOLE_P	PCIE_BRIDGE_RST_L
8	GND	SDIO DATA[3]	GND	GND	USB_CONSOLE_N	GND
9	SDIO DATA[1]	GND	SDIO DIR DATA[1:3]	USB_HOST_P	GND	RS232 CONSOLE RX
10	GND	SDIO CMD	GND	USB_HOST_N	GND	RS232 CONSOLE TX
11	SDIO DATA[2]	GND	SDIO DIR DATA[0]	GND	RSVD	GND
12	SDIO SEL	SDIO CLK	SDIO CD_L	GND	RSVD	GND
13	SDIO WP_L	SDIO BUS POWER	P1_8V	RSVD	RSVD	EXPANSION[1] MDIO
14	GND	GND	GND	RSVD	RSVD	EXPANSION[1] MDC
15	QSGMII_MAIN_EXP_LANE1_P	GND	CLK_MAIN_EXP_P	GND	EXPANSION[2] MDIO	GND

PIN #	Row A	Row B	Row C	Row D	Row E	Row F
16	QSGMII_MAIN_EXP_LANE1_N	GND	CLK_MAIN_EXP_N	GND	EXPANSION[2] MDC	GND
17	GND	QSGMII_EXP_MAIN_LANE1_P	GND	HOST I2C SDA	GND	EXPANSION[2] I2C
18	GND	QSGMII_EXP_MAIN_LANE1_N	GND	HOST I2C SCL	GND	EXPANSION[2] I2C
19	QSGMII_MAIN_EXP_LANE2_P	GND	PTP_SYNC	GND	EXPANSION[1] I2C SDA	GND
20	QSGMII_MAIN_EXP_LANE2_N	GND	CISCO DEBUG[0]	GND	EXPANSION[1] I2C SCL	GND
21	GND	QSGMII_EXP_MAIN_LANE2_P	GND	LED SCLK	GND	LED MOSI
22	GND	QSGMII_EXP_MAIN_LANE2_N	GND	LED MISO	GND	LED MAIN CS_L
23	QSGMII_MAIN_EXP_LANE3_P	GND	POE_SPI_SCLK	GND	LED EXPANSION CS_L	LED RST_L
24	QSGMII_MAIN_EXP_LANE3_N	GND	POE_SPI_MISO	GND	RSVD	DC A GOOD
25	GND	QSGMII_EXP_MAIN_LANE3_P	GND	DYING_GASP_L	PUSHBUTTON_L	DC B GOOD
26	GND	QSGMII_EXP_MAIN_LANE3_N	GND	ALARM_IN1_L	ALARM_IN2_L	ALARM OUT L
27	QSGMII_MAIN_EXP_LANE4_P	GND	POE_SPI_MOSI	POE[1] RST_L	POE[1] PRESENT	MODULE_PRESENT_L
28	QSGMII_MAIN_EXP_LANE4_N	GND	POE_SPI_CS_L	EXPANSION[1] POWER ENABLE	EXPANSION[1] RST_L	EXPANSION[2] IRQA
29	GND	QSGMII_EXP_MAIN_LANE4_P	GND	EXPANSION[1] IRQB	EXPANSION[2] POWER ENABLE	EXPANSION[2] RST_L
30	GND	QSGMII_EXP_MAIN_LANE4_N	GND	GND	EXPANSION[1] IRQA	EXPANSION[2] IRQB
31	PCIE_ROOT_BRIDGE_P	GND	RSVD	RSVD	RSVD	POE_LOADSHED_L
32	PCIE_ROOT_BRIDGE_N	GND	RSVD	RSVD	RSVD	GND
33	GND	PCIE_BRIDGE_EP_P	RSVD	RSVD	GND	RSVD
34	GND	PCIE_BRIDGE_EP_N	RSVD	GND	RSVD	GND
35	PCIE_BRIDGE_ROOT_P	GND	HOST_IRQ_L	RSVD	GND	RSVD

PIN #	Row A	Row B	Row C	Row D	Row E	Row F
36	PCIE_BRIDGE_ROOT_N	GND	RSVD	GND	RSVD	GND
37	GND	PCIE_EP_BRIDGE_P	RSVD	RSVD	RSVD	GND
38	GND	PCIE_EP_BRIDGE_N	GND	RSVD	RSVD	GND
39	1PPS	GND	RSVD	RSVD	RSVD	GND
40	1PPS_ENABLE	GND	GND	RSVD	RSVD	GND

Expansion Board Interface Connectors (I/O and Network Interface)

This section shows the locations and designations of the two Expansion Board interface connectors.

ESS-3300 Expansion Board I/O Connector (J1)

The Expansion Board I/O connectors (J1 and J2) are a SAMTEC SEAF-40-05.0-S-06-2-A-K 240-pin connector. The following tables provide a pinout listing for the I/O connectors, as well as the pin numbering convention.

Figure 13: Expansion Board I/O Connector

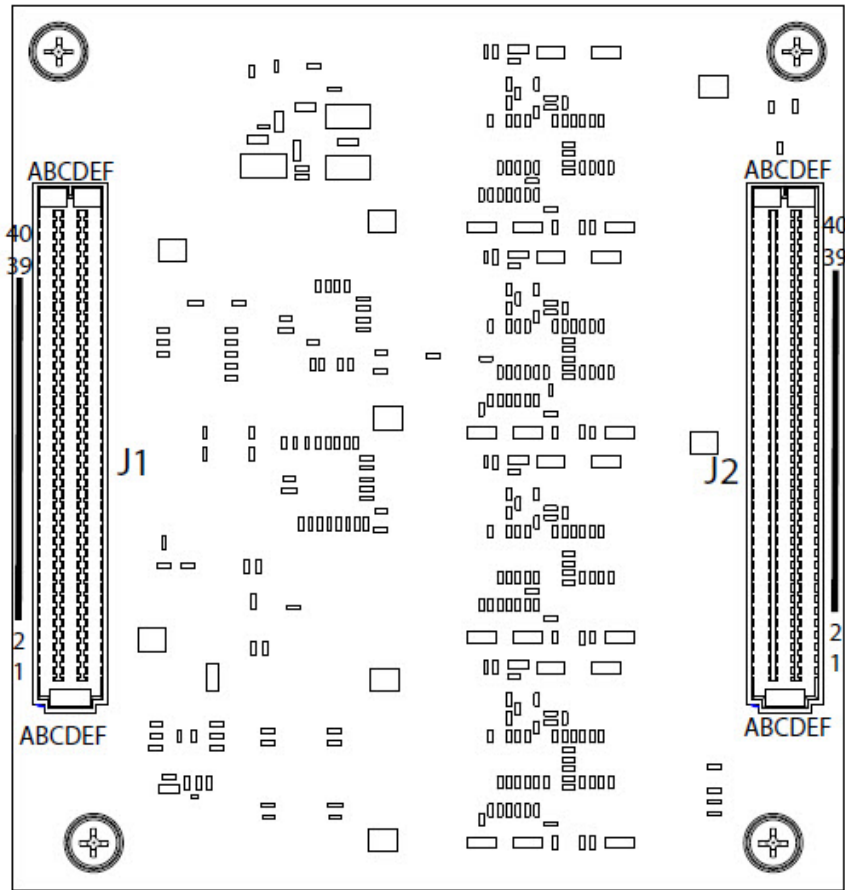

PIN #	Row A	Row B	Row C	Row D	Row E	Row F
1	P5V	P5V	P5V	P5V	P5V	P5V
2	P5V	P5V	P5V	P5V	P5V	P5V
3	GND	GND	GND	GND	GND	GND
4	GND	GND	GND	GND	GND	GND
5	P3_3V	P3_3V	P3_3V	P3_3V	P3_3V	P3_3V
6	GND	GND	GND	GND	GND	GND
7	PTP_SYNC	GND	RSVD	GND	SFP Gi2/3 SCL	SFP Gi2/2 SCL

PIN #	Row A	Row B	Row C	Row D	Row E	Row F
8	GND	NC	GND	GND	GND	GND
9	NC]	GND	NC	EXPANSION[2] MDIO	SFP Gi2/3 SDA	SFP Gi2/2 SDA
10	GND	NC	GND	EXPANSION[2] MDC	GND	GND
11	CLK_MAIN_EXP_P	GND	NC	GND	SFP Gi2/3 RXLOS	SFP Gi2/2 RXLOS
12	CLK_MAIN_EXP_N	NC	NC	GND	SFP Gi2/3 TXFLT	SFP Gi2/2 TXFLT
13	GND	NC	NC	RSVD	SFP Gi2/3 PRES_	SFP Gi2/2 PRES_L
14	GND	GND	GND	RSVD	SFP Gi2/3 TXDIS	SFP Gi2/2 TXDIS
15	QSGMII_MAIN_EXP_LANE1_P	GND	NC	GND	SFP Gi2/3 PWR EN	SFP Gi2/2 PWR EN
16	QSGMII_MAIN_EXP_LANE1_N	GND	NC	GND	GND	GND
17	GND	QSGMII_EXP_MAIN_LANE1_P	GND	EXPANSION[1]I2C SDA	SFP Gi2/4 SCL	RSVD
18	GND	QSGMII_EXP_MAIN_LANE1_N	GND	EXPANSION[1]I2C SCL	GND	GND
19	QSGMII_MAIN_EXP_LANE2_P	GND	NC	GND	SFP Gi2/4 SDA	RSVD
20	QSGMII_MAIN_EXP_LANE2_N	GND	NC	GND	GND	GND
21	GND	QSGMII_EXP_MAIN_LANE2_P	GND	EXPANSION[2]I2C SDA	SFP Gi2/4 RXLOS	RSVD
22	GND	QSGMII_EXP_MAIN_LANE2_N	GND	EXPANSION[2]I2C SCL	SFP Gi2/4 TXFLT	GND
23	QSGMII_MAIN_EXP_LANE3_P	GND	NC	GND	SFP Gi2/4 PRES_L	RSVD
24	QSGMII_MAIN_EXP_LANE3_N	GND	NC	GND	SFP Gi2/4 TXDIS	GND
25	GND	QSGMII_EXP_MAIN_LANE3_P	GND	EXPANSION[1]RST_L	SFP Gi2/4 PWR EN	RSVD

PIN #	Row A	Row B	Row C	Row D	Row E	Row F
26	GND	QSGMII_EXP_MAIN_LANE3_N	GND	EXPANSION[2] POWER ENABLE	GND	NC
27	QSGMII_MAIN_EXP_LANE4_P	GND	NC	EXPANSION[1]IRQA	SFP Gi2/1 SCL	NC
28	QSGMII_MAIN_EXP_LANE4_N	GND	NC	EXPANSION[1] POWER ENABLE	GND	NC
29	GND	QSGMII_EXP_MAIN_LANE4_P	GND	EXPANSION[1]IRQB	SFP Gi2/1 SDA	NC
30	GND	QSGMII_EXP_MAIN_LANE4_N	GND	GND	GND	NC
31	RSVD	GND	NC	MODULE_PRESENT_L	SFP Gi2/1 RXLOS	NC
32	RSVD	GND	NC	EXPANSION[2]IRQA	SFP Gi2/1 TXFLT	NC
33	GND	RSVD	GND	EXPANSION[2]RST_L	SFP Gi2/1 PRES_L	NC
34	GND	RSVD	GND	EXPANSION[2]IRQB	SFP Gi2/1 TX DIS	NC
35	RSVD	GND	NC	GND	SFP Gi2/1 PWREN	NC
36	RSVD	GND	NC	GND	GND	GND
37	GND	RSVD	GND	EXPANSION[1]MDIO	NC	POE[2] PRESENT
38	GND	RSVD	GND	EXPANSION[1]MDC	NC	POE[2] RST_L
39	NC	GND	NC	GND	NC	POE[3] PRESENT
40	NC	GND	NC	GND	NC	POE[3] RST_L

ESS-3300 Expansion Board Network Interface Connector (J2)

PIN #	Row A	Row B	Row C	Row D	Row E	Row F
1	SFP Gi2/3 TXD P	GND	SFP Gi2/1 TXD P	GND	GND	GND
2	SFP Gi2/3 TXD N	SFP Gi2/3 RXD P	SFP Gi2/1 TXD N	SFP Gi2/1 RXD P	GND	GND
3	GND	SFP Gi2/3 RXD N	GND	SFP Gi2/1 RXD N	GND	GND
4	SFP Gi2/4 TXD P	GND	SFP Gi2/2 TXD P	GND	GND	GND
5	SFP Gi2/4 TXD N	SFP Gi2/4 RXD P	SFP Gi2/2 TXD N	SFP Gi2/2 RXD P	GND	GND

PIN #	Row A	Row B	Row C	Row D	Row E	Row F
6	GND	SFP Gi2/4 RXD N	GND	SFP Gi2/2 RXD N	GND	GND
7	Gi2/3 MDI0 P	GND	Gi2/3 MDI2 P	GND	Gi2/1 MDI0 P	GND
8	Gi2/3 MDI0 N	Gi2/3 MDI1 P	Gi2/3 MDI2 N	Gi2/3 MDI3 P	Gi2/1 MDI0 N	Gi2/1 MDI1 P
9	GND	Gi2/3 MDI1 N	GND	Gi2/3 MDI3 N	GND	Gi2/1 MDI1 N
10	Gi2/4 MDI0 P	GND	Gi2/4 MDI2 P	GND	Gi2/1 MDI2 P	GND
11	Gi2/4 MDI0 N	Gi2/4 MDI1 P	Gi2/4 MDI2 N	Gi2/4 MDI3 P	Gi2/1 MDI2 N	Gi2/1 MDI3 P
12	GND	Gi2/4 MDI1 N	GND	Gi2/4 MDI3 N	GND	Gi2/1 MDI3 N
13	Gi2/2 MDI0 P	GND	Gi2/2 MDI2 P	GND	Gi2/8 MDI0 P	GND
14	Gi2/2 MDI0 N	Gi2/2 MDI1 P	Gi2/2 MDI2 N	Gi2/2 MDI3 P	Gi2/8 MDI0 N	Gi2/8 MDI1 P
15	GND	Gi2/2 MDI1 N	GND	Gi2/2 MDI3 N	GND	Gi2/8 MDI1 N
16	Gi2/7 MDI0 P	GND	Gi2/7 MDI2 P	GND	Gi2/8 MDI2 P	GND
17	Gi2/7 MDI0 N	Gi2/7 MDI1 P	Gi2/7 MDI2 N	Gi2/7 MDI3 P	Gi2/8 MDI2 N	Gi2/8 MDI3 P
18	GND	Gi2/7 MDI1 N	GND	Gi2/7 MDI3 N	GND	Gi2/8 MDI3 N
19	Gi2/5 MDI0 P	GND	Gi2/5 MDI2 P	GND	Gi2/11 MDI0 P	GND
20	Gi2/5 MDI0 N	Gi2/5 MDI1 P	Gi2/5 MDI2 N	Gi2/5 MDI3 P	Gi2/11 MDI0 N	Gi2/11 MDI1 P
21	GND	Gi2/5 MDI1 N	GND	Gi2/5 MDI3 N	GND	Gi2/11 MDI1 N
22	Gi2/6 MDI0 P	GND	Gi2/6 MDI2 P	GND	Gi2/11 MDI2 P	GND
23	Gi2/6 MDI0 N	Gi2/6 MDI1 P	Gi2/6 MDI2 N	Gi2/6 MDI3 P	Gi2/11 MDI2 N	Gi2/11 MDI3 P
24	GND	Gi2/6 MDI1 N	GND	Gi2/6 MDI3 N	GND	Gi2/11 MDI3 N
25	Gi2/12 MDI0 P	GND	Gi2/12 MDI2 P	GND	Gi2/10 MDI0 P	GND
26	Gi2/12 MDI0 N	Gi2/12 MDI1 P	Gi2/12 MDI2 N	Gi2/12 MDI3 P	Gi2/10 MDI0 N	Gi2/10 MDI1 P
27	GND	Gi2/12 MDI1 N	GND	Gi2/12 MDI3 N	GND	Gi2/10 MDI1 N
28	Gi2/9 MDI0 P	GND	Gi2/9 MDI2 P	GND	Gi2/10 MDI2 P	GND

PIN #	Row A	Row B	Row C	Row D	Row E	Row F
29	Gi2/9 MDI0 N	Gi2/9 MDI1 P	Gi2/9 MDI2 N	Gi2/9 MDI3 P	Gi2/10 MDI2 N	Gi2/10 MDI3 P
30	GND	Gi2/9 MDI1 N	GND	Gi2/9 MDI3 N	GND	Gi2/10 MDI3 N
31	Gi2/15 MDI0 P	GND	Gi2/15 MDI2 P	GND	Gi2/13 MDI0 P	GND
32	Gi2/15 MDI0 N	Gi2/15 MDI1 P	Gi2/15 MDI2 N	Gi2/15 MDI3 P	Gi2/13 MDI0 N	Gi2/13 MDI1 P
33	GND	Gi2/15 MDI1 N	GND	Gi2/15 MDI3 N	GND	Gi2/13 MDI1 N
34	Gi2/16 MDI0 P	GND	Gi2/16 MDI2 P	GND	Gi2/13 MDI2 P	GND
35	Gi2/16 MDI0 N	Gi2/16 MDI1 P	Gi2/16 MDI2 N	Gi2/16 MDI3 P	Gi2/13 MD2 N	Gi2/13 MDI3 P
36	GND	Gi2/16 MDI1 N	GND	Gi2/16 MDI3 N	GND	Gi2/13 MDI3 N
37	Gi2/14 MDI0 P	GND	Gi2/14 MDI2 P	GND	GND	GND
38	Gi2/14 MDI0 N	Gi2/14 MDI1 P	Gi2/14 MDI2 N	Gi2/14 MDI3 P	GND	NC
39	GND	Gi2/14 MDI1 N	GND	Gi2/14 MDI3 N	GND	NC
40	NC	GND	NC	GND	NC	NC

Board to Board Connectors

Both the Main Board and the Expansion Board use the SEARAY® Connector Series from SAMTEC. Depending on the mating connector selected by the integrator, a stacking height from 7 mm to 18mm (not all increments are supported). Table 8 lists the board connectors and the mating connector options that are available to achieve specific stacking heights below (The Main and Expansion Boards use the -05.0 SEAF Lead Style shown in the following table.



Note Contact your local Samtec sales representatives for specific Samtec part numbers.

SEAM Lead Style	-05.0 SEAF Lead Style
-02.0	7mm
-03.0	8mm
-03.5	8.5mm

SEAM Lead Style	-05.0 SEAF Lead Style
-05.5	NA
-06.5	11.5mm
-07.0	12mm
-09.0	14mm
-11.0	16mm
-13.0 (not tooled)	18mm



CHAPTER 3

Implementation Options

This chapter contains the following sections:

- [LED Definitions, on page 25](#)
- [Main Module I/O Description, on page 31](#)
- [PCIe Loopback, on page 32](#)
- [Main Module Voltage Test Points, on page 32](#)
- [Mechanical and Environmental Testing, on page 34](#)
- [Overtemperature Detection, on page 36](#)
- [Thermal Design Considerations, on page 37](#)
- [Product Specifications, on page 41](#)
- [Power Requirements, on page 43](#)
- [Power Over Ethernet \(PoE\), on page 44](#)
- [SD Support, on page 45](#)
- [SFP Support, on page 45](#)

LED Definitions

LED functionality is provided by a dedicated SPI controller for driving two LED shift chains for driving the LEDs on the integrator's board. The first LED shift chain connects all of the LEDs associated with the Main Board. The second LED shift chain connects all of the LEDs associated with the Expansion Board. You can select any combination of LEDs listed in the following table to implement. You are not required to implement all of the LEDs.



Note Both shift chains are optional. If you want any functionality from a given shift chain, then you must provide the entire shift chain. For example, if you want the copper LEDs on the Expansion Module shift chain, you must also populate the shift register associated with the SFPs interfaces.

LED	Color	Description
System See Note below for further details about bootup behavior.	Off	System is not powered on.
	Flashing Green	Power on tests in progress.
	Green	System is operating normally.
	Yellow	System fault detected.
Power	Off	Power is not present or unit failed memory test.
	Green	System is powered on.
Alarm Out	Off	Alarm is not configured.
	Solid Green	Alarm Out is configured, no alarm detected.
	Flashing Red	Switch has detected a major alarm.
	Solid Red	Switch has detected a minor alarm.
Port	Off	No link or the port was administratively shut down.
	Green	Link is present; no activity
	Flashing Green	Activity. The port is sending or receiving data.
	Alternating Green and Yellow	Link fault. Error frames can affect connectivity. Errors such as excessive collisions, cyclic redundancy check (CRC), and alignment and jabber errors are monitored for link-fault indication.
	Yellow	Port is disabled.

LED	Color	Description
PoE	Off	PoE is off. If the powered device is receiving power from a non-PoE power source, the port LED is off even if the powered device is connected to the switch port.
	Green	PoE is on. The port LED is green only when the PoE port is providing power.
	Alternating Green and Amber	PoE is denied because providing power to the powered device will exceed the switch power capacity.
	Flashing Amber	PoE is off due to a fault. Caution Non-compliant cabling or powered devices can cause a PoE port fault. Use only standard compliant cabling to connect Cisco pre-standard IP Phones and wireless access points or IEEE 802.3af-compliant devices. You must remove any cable or device that causes a PoE fault.
	Amber	PoE for the port is disabled. (PoE is enabled by default).
Zeroize	Off	Normal operation.
	Flashing Green	Factory default procedure has been initiated.
	Yellow	Factory default procedure has completed; switch is about to reboot.
	Green	Factory default procedure has completed.



Note The System LED will be solid green once the unit is booted up into IOS. That is the expected behavior. The LED should stop blinking shortly after the “Taking LC1 out of reset” text if you do not have an Expansion module. If you have an expansion module, the LED will stop blinking shortly after the “Taking LC3 out of reset” text.

Main Board LED Register Bits



Note Express Setup is not supported on the ESS3300 since the push button input and corresponding LED’s are dedicated to the Zeroize feature. Since the ESS3300 and IE3300 share a common architecture, any reference to Express Setup is reused for the Zeroize feature in the context of the ESS3300.

The following table provides a listing of the Main Board LED register bits for the system integrator.

GPIO Position	LED Function
0 (Least Significant bit in byte, last to shift out)	SYS Yellow LED

GPIO Position	LED Function
1	SYS Green LED
2	Express Setup Yellow LED
3	Express Setup Green LED
4	PoE Yellow LED
5	PoE Green LED
6	DC-A Yellow LED
7 (Most Significant bit in byte, First to shift out)	DC-A Green LED
8 (Least Significant bit in byte, last to shift out)	DC-B Yellow LED
9	DC-B Green LED
10	Reserved Yellow LED
11	Reserved Green LED
12	SFP Te1/1 Yellow LED
13	SFP Te1/1 Green LED
14	SFP Te1/2 Yellow LED
15 (Most Significant bit in byte, First to shift out)	SFP Te1/2 Green LED
16 (Least Significant bit in byte, last to shift out)	SFP Gi1/3 Yellow LED (i.e. Combo Port 1, SFP)
17	SFP Gi1/3 Green LED (i.e. Combo Port 1, SFP)
18	SFP Gi1/4 Yellow LED (i.e. Combo Port 2, SFP)
19	SFP Gi1/4 Green LED (i.e. Combo Port 2, SFP)
20	SFP Gi1/5 Yellow LED (i.e. Combo Port 3, SFP)
21	SFP Gi1/5 Green LED (i.e. Combo Port 3, SFP)
22	SFP Gi1/6 Yellow LED (i.e. Combo Port 4, SFP)
23 (Most Significant bit in byte, First to shift out)	SFP Gi1/6 Green LED (i.e. Combo Port 4, SFP)
24 (Least Significant bit in byte, last to shift out)	Gi1/3 Yellow LED (i.e. Combo Port 1, Cu)
25	Gi1/3 Green LED (i.e. Combo Port 1, Cu)
26	Gi1/4 Yellow LED (i.e. Combo Port 2, Cu)
27	Gi1/4 Green LED (i.e. Combo Port 2, Cu)
28	Gi1/5 Yellow LED (i.e. Combo Port 3, Cu)

GPIO Position	LED Function
29	Gi1/5 Green LED (i.e. Combo Port 3, Cu)
30	Gi1/6 Yellow LED (i.e. Combo Port 4, Cu)
31 (Most Significant bit in byte, First to shift out)	Gi1/6 Green LED (i.e. Combo Port 4, Cu)
32 (Least Significant bit in byte, last to shift out)	Gi1/7 Yellow LED
33	Gi1/7 Green LED
34	Gi1/8 Yellow LED
35	Gi1/8 Green LED
36	Gi1/9 Yellow LED
37	Gi1/9 Green LED
38	Gi1/10 Yellow LED
39 (Most Significant bit in byte, First to shift out)	Gi1/10 Green LED
40	Alarm Out / Overtemp Yellow LED
41	Alarm Out / Overtemp Green LED
42	Alarm In 1 Yellow LED
43	Alarm in 1 Green LED
44	Alarm In 2 Yellow LED
45	Alarm In 2 Green LED
46	Reserved Yellow LED
47	Reserved Green LED

Expansion Board LED Register Bits

The following table provides a listing of the Expansion Board LED register bits for the system integrator.

GPIO Position	LED Function
0 (Least Significant bit in byte, last to shift out)	Gi2/1 Yellow LED
1	Gi2/1 Green LED
2	Gi2/2 Yellow LED
3	Gi2/2 Green LED
4	Gi2/3 Yellow LED

GPIO Position	LED Function
5	Gi2/3 Green LED
6	Gi2/4 Yellow LED
7 (Most Significant bit in byte, First to shift out)	Gi2/4 Green LED
8 (Least Significant bit in byte, last to shift out)	Gi2/5 Yellow LED
9	Gi2/5 Green LED
10	Gi2/6 Yellow LED
11	Gi2/6 Green LED
12	Gi2/7 Yellow LED
13	Gi2/7 Green LED
14	Gi2/8 Yellow LED
15 (Most Significant bit in byte, First to shift out)	Gi2/8 Green LED
16 (Least Significant bit in byte, last to shift out)	Gi2/9 Yellow LED
17	Gi2/9 Green LED
18	Gi2/10 Yellow LED
19	Gi2/10 Green LED
20	Gi2/11 Yellow LED
21	Gi2/11 Green LED
22	Gi2/12 Yellow LED
23 (Most Significant bit in byte, First to shift out)	Gi2/12 Green LED
24 (Least Significant bit in byte, last to shift out)	Gi2/13 Yellow LED
25	Gi2/13 Green LED
26	Gi2/14 Yellow LED
27	Gi2/14 Green LED
28	Gi2/15 Yellow LED
29	Gi2/15 Green LED
30	Gi2/16 Yellow LED
31 (Most Significant bit in byte, First to shift out)	Gi2/16 Green LED
32 (Least Significant bit in byte, last to shift out)	SFP Gi2/3 Yellow LED

GPIO Position	LED Function
33	SFP Gi2/3 Green LED
34	SFP Gi2/4 Yellow LED)
35	SFP Gi2/4 Green LED
36	SFP Gi2/1 Yellow LED
37	SFP Gi2/1 Green LED
38	SFP Gi2/2 Yellow LED
39 (Most Significant bit in byte, First to shift out)	SFP Gi2/2 Green LED

Main Module I/O Description

The following table provides details on the I/O signals.

IO Name	Description	Direction	I/O Standard	Notes
QSGMII_MAIN_EXP_*	Provides Ethernet connectivity between the Main and Expansion modules.	Output	LVDS	All four lanes must be populated if the Expansion module is used.
QSGMII_EXP_MAIN_*	Provides Ethernet connectivity between the Main and Expansion modules.	Input	LVDS	All four lanes must be populated if the Expansion module is used.
PCIE_*	Provides future PCIe expandability.	Bidirectional	LVDS	Important See the PCIe Loopback , on page 32 section.
SDIO1_*	SD card interface.	Bidirectional	1.8V	Requires a level translator for proper operation. Please see the reference design for details.
PUSHBUTTON_L	Provides Zero-ize functionality.	Input	3.3V	The module has an internal Pull Up.
CLK_MAIN_EXPANSION	156.25 MHz Reference Clock from the Main module to the Expansion module.	Output	LVDS	Must be populated if the Expansion module is used.
PTP_SYNC	PTP Alignment Clock between Main and Expansion module.	Output	3.3V	Must be populated if the Expansion module is used, even if PTP is not used.
LED_*	LED Shift Chain Interface.	Output Input	1.8V	Drives shift registers for Main and Expansion Module LEDs.

IO Name	Description	Direction	I/O Standard	Notes
ALARM_OUT_L	IOS Alarm asserts this signal.	Output	3.3V	
ALARM_INx_L	Provides Alarm indication to IOS.	Input	3.3V	The module has an internal Pull Up.

PCle Loopback

The ESS-3300 requires integrators to provide an external connection between the CPU's Root Complex and a PCIe endpoint on the ESS-3300 Main Module. The PCIe interface is exposed to the integrator for future use.

Integrators must connect the following Main Module I/O connector pins with PCIe Gen2 compatible AC coupling capacitors between the two pins:

A31 to B33

A32 to B34

A35 to B37

A36 to B38

Main Module Voltage Test Points

The following figure shows voltage test points on the main module with descriptions in the following table.



Note Red lines are Positive, Blue lines are Ground.

Figure 14: Voltage Test Points

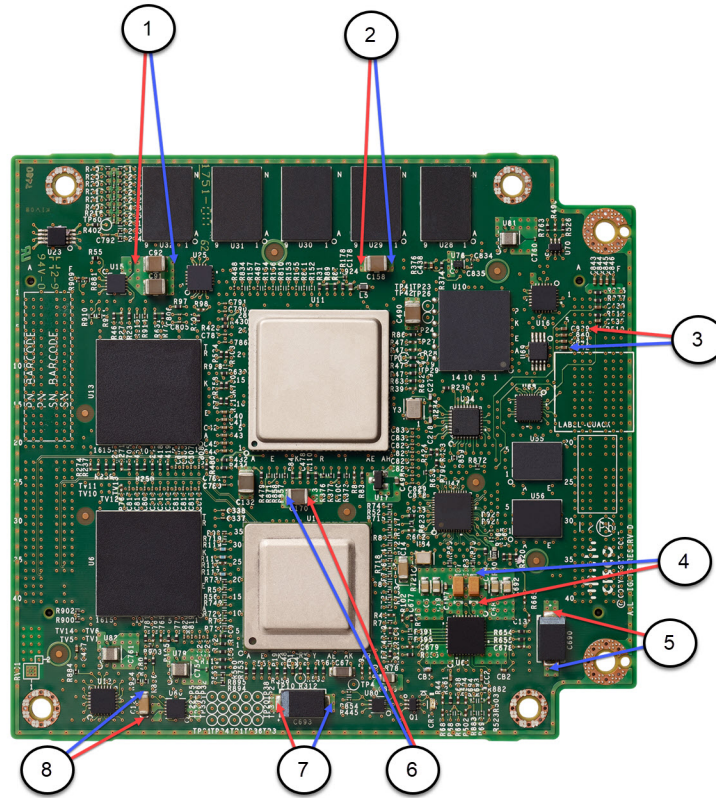

Test Point	Location	Voltage
1	C91-92	0.6V
2	C158	1.2V
3	C839-C842	3.3V from carrier
4	C7-C683	5.0V from carrier
5	C690	0.85V
6	C170	1.8V
7	C693	1.0V
8	C124	3.3V (after converter)

Mechanical and Environmental Testing

The tests listed in the following table were successfully executed on the conduction-cooled models of the Cisco ESS-3300. These tests used a representative enclosure that conforms to the mounting and thermal mechanisms shown in [Thermal Design Considerations, on page 37](#). Because this type of testing is highly dependent on factors such as the test enclosure design, the thermal solution, the front panel connectors, and the mounting, the following test results should only be used as a reference.

Table 1: Temperature

High and Low Temperature Cycle Stress (Operational)	High Temperature: 74°C (165°F) Low Temperature: -40°C (-40°F) Reference: MIL-STD-810F, Method 501.4, Procedure II and Method 502.4, Procedure II; SAE J1455 (Rev AUG94), Section 4.1.3
Thermal Shock (Non-Operational)	High Temperature: 85°C (185 °F) Low Temperature: -40°C (-40 °F) Cycle: 2 hours high temperature, 2 hours low temperature Test Period: 2 hour pre-soak at low temperature, followed by 5 cycles Repetition: 5 test periods Reference: MIL-STD-810F, Method 503.4; SAE J1455 (Rev AUG94), Section 4.1.3.2
High Temperature Component Thermal Test (Operational)	Method: Thermocouples on all critical/hot components at board level. Bring temperature of top center surface of thermal plate to 85°C (185 °F) and allow it to stabilize. Ensure that all components are within manufacturer thermal specifications.

Table 2: Altitude

Low Pressure/Altitude (Operational)	Altitude: 4,572m (15,000ft) Equivalent Absolute Pressure: 57.2 kPa (8.3 lbf/in2) Temperature: -40°C (-40°F) to 74°C (165°F) Altitude Ramp Rate: 10m/s (max) Temperature Ramp Rate: 1.5°C (min) to 4.5°C (max) Reference: MIL-STD 810F, Method 500.4, Procedure II; SAE J1455 (Rev AUG94), Section 4.1.3.1
--	--

<p>Low Pressure/Altitude (Non-Operational)</p>	<p>Altitude: 12.2km (40,000 ft) Equivalent Absolute Pressure: 18.6kPa (2.7lbf/in2) Temperature: -40°C (-40°F) to 85°C (185°F) Altitude Ramp Rate: 10m/s (max) Temperature Ramp Rate: 1.5°C (min) to 4.5°C (max) Reference: MIL-STD-810F, Method 500.4; SAE J1455 (Rev AUG94), Section 4.1.3.1</p>
--	--

Table 3: Humidity

<p>Temperature & Humidity Cycle Stress (Non-Operational; Energized)</p>	<p>Humidity: 95% +/- 5% RH Pressure: 103.4 kPa (15 lbf in2) Temperature: -40°C (-40°F) to 65°C (149°F) Cycle: One, 24 hour cycle Reference: SAE J1455 (Rev AUG94), Section 4.2.3</p>
<p>Active Temperature/Humidity 10 Day Soak (Non-Operational; Energized)</p>	<p>Temperature: -40°C (-40°F) to 65 °C (149 °F) Humidity: 95% +/- 5% RH Cycle: Ramp from 25°C to -40°C over 75 minute period, dwell at -40°C for 240 minutes, ramp to 65°C over 120 minute period, dwell at 65°C for 240 minutes (95% +/- 5% RH), ramp to 25°C over 45 minute period, dwell at 25°C for 120 minutes (50% +/- 5% RH) Repetition: 20 total cycles (10 days total) Reference: MIL-STD-810F, Method 507.4; SAE J1211 (Rev NOV78), Section 4.2.2; SAE J1455 (Rev AUG94), Section 4.2.3</p>

Table 4: Vibration

<p>Random Vibration (Operational)</p>	<p>Acceleration: 1.04g rms vertical, 0.204g rms transverse, 0.740g rms longitudinal Duration: 2 hours per axis Test orientation: 3 axes Reference: MIL-STD-810F, Method 514.5, Category 4</p>
---	--

Table 5: Shock

Crash Hazard Shock (Non-Operational)	Acceleration: 75G Duration: 8-13ms Test orientation: 3 axes (positive and negative) Number of shocks: 2 shocks in each direction, 12 shocks total Reference: MIL-STD-810F, Method 516.5, Procedure V
Functional Shock (Operational)	Acceleration: 40G Duration: 15-23ms Test orientation: All 6 faces, in 3 perpendicular axes Reference: MIL-STD-810F, Method 516.5, Procedure I
Bench handling shock (tip) (Operational)	Test orientation: All four edges of each face to form 10° angle with bench top Reference: MIL-STD-810F, Method 516.5, Procedure VI

Overtemperature Detection

Both the Main Board and the Expansion Board have a temperature sensor mounted on the edge of the board and thermally attached to the cooling plate. When the temperature sensor on either the Main Board or the Expansion Board detects a temperature exceeding the temperature threshold of 203°F (95°C), the overtemperature LED will illuminate. The temperature sensor is identified as U23 in [Thermal Design Considerations, on page 37](#).

The digital temperature sensor measures the temperature of the conduction plate (or the integrators equivalent of the conduction plate), not the local ambient temperature. The product datasheet states the board will operate as long as the conduction plate is in the range of -40C to +85C. The alarms are set accordingly and the high temperature alarm thresholds are set as follows:

- Minor alarm at +80C the conduction plate temperature is close to the rated thermal limit of the unit, and will notify the user. The components are still within the specification, so there is no degradation to the long term reliability of the system.
- Major alarm at +90C the conduction plate temperature is over the rated thermal limit of the unit, and will notify the user. This will impact the long term reliability of the system.
- Critical alarm at +96C the conduction plate temperature is way over the rated thermal limit of the unit, and will notify the user. This will impact the long term reliability of the system. For the Critical Alarm threshold to be reached, it means that the ambient temperature of the system will be exceeded. Hardware failure is imminent, and the failure time will depend upon your installation. Depending on the severity at this point, the failure may be temporary or permanent.



Caution

IOS will never shut down a device because the temperature exceeds the specification. Cisco does not guarantee the functionality, nor the long term reliability of a device operating beyond Cisco specifications, but lets the device continue operating until some piece of hardware physically shuts down. Operating outside of the temperature specifications will void the product warranty.

The status of the temperature sensors can be reported from the Cisco ESS-3300 IOS CLI:

```
Switch# show environment all
ALARM CONTACT 1
  Status:      not asserted
  Description: external alarm contact 1
  Severity:    minor
  Trigger:     closed
ALARM CONTACT 2
  Status:      not asserted
  Description: external alarm contact 2
  Severity:    minor
  Trigger:     closed
Supervisor Temperature Value: 51 C
Temperature State: GREEN
System Temperature thresholds
-----
Minor Threshold   : 80 C (Yellow)
Major Threshold   : 90 C (Red)
Critical Threshold : 96 C
Shutdown Threshold : 105 C
Pwr Supply        Type      Status
-----
POWER SUPPLY-A    DC       OK
POWER SUPPLY-B    DC       OK
```

Thermal Design Considerations

The following sections outline the methods for dealing with thermal issues and the mounting options involving the Cisco-designed conduction cooling plate.

As the Cisco ESS 3300 is intended for use in extreme environments, industrial temperature rated components are used. The SKUs with a thermal plate make integration easier by abstracting the component level thermal concerns. Cisco has already performed the thermal analysis at the component level so that the integrator need only be concerned with the thermal plate temperature. As a general rule, the thermal plate of the card needs to make contact with an adequate thermal mass to draw heat away from the card. This can be done in a number of ways.



Important The thermal plate temperature, as measured at the center of the top surface of the thermal plate, must not exceed 85° C. As long as this requirement is satisfied, all of the card's components will be within a safe operating temperature range on the high temperature side.

Heat dissipation methods:

As a general rule, the thermal plate of the board needs to make contact with an adequate thermal mass to draw heat away from the board. There are many ways to achieve this goal.

Examples:

- Transfer heat away from the thermal plate and into the enclosure wall by utilizing a “shelf” of metal. The shelf encompasses the entire Cisco ESS 3300 thermal plate surface. This shelf is illustrated by item 1 in the following figure.
- Mount the Cisco ESS 3300 thermal plate directly to the enclosure wall by using thermal interface material.

Figure 15: Thermally Significant Components of Cisco ESS-3300 (Main Card)

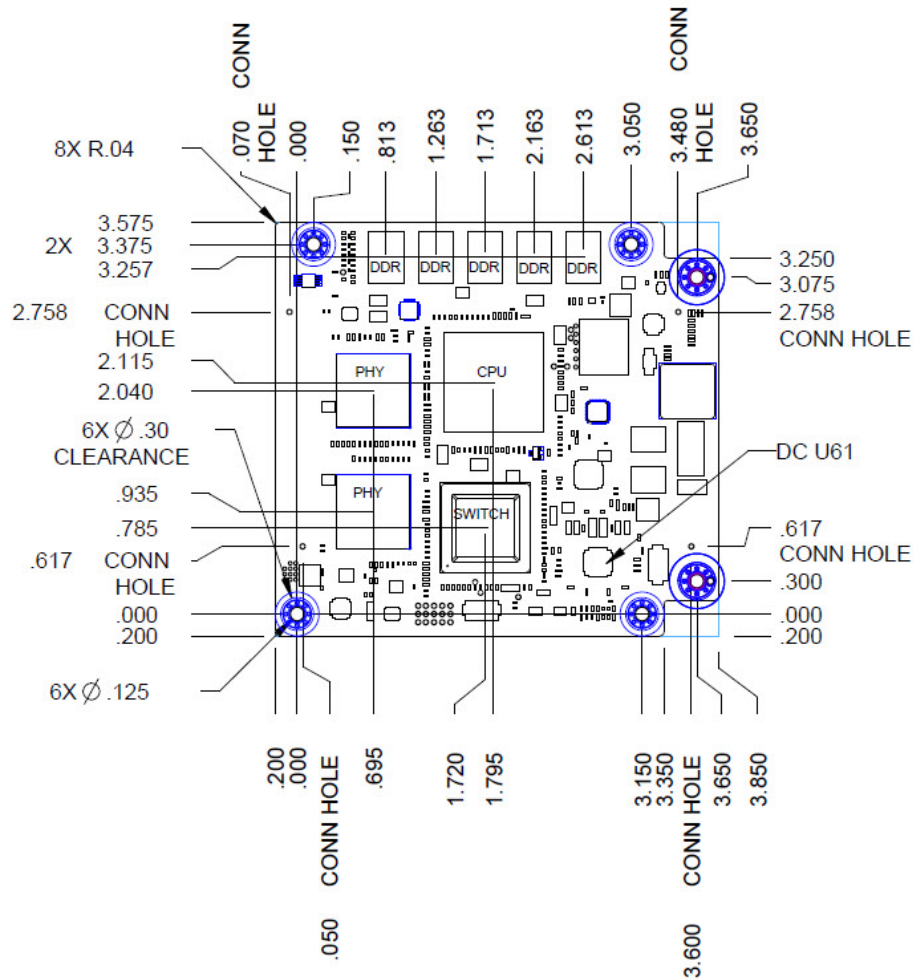

Table 6: Thermal Details for the Thermally Significant Components of Cisco ESS 3300 (Main Card)

RefDes	Thermal Design Power (W)	Allowable Junction Temperature	Allowable Case Temperature	Package Type	Theta JC (degC/W)	Theta JB (degC/W)
U1	5.6	115	—	HFCBGA573	.55	5.55
U11	4.9	100	—	SFVC784	0.5	2.67
U28	0.2 each	—	95	FBGA96	3.0	—
U29						
U30						
U31						
U32						

RefDes	Thermal Design Power (W)	Allowable Junction Temperature	Allowable Case Temperature	Package Type	Theta JC (degC/W)	Theta JB (degC/W)
U6 U13	1.5 each	110	—	FBGA256	13.6	16.45
U61	1	125	—	VQFN	18.8	6
U23	—	125	—	MSOP8	—	—



Note Cisco uses the following TIMs at each REFDES:

The U23, U28, U29, U30, U31, U32, and U61 use the Chomerics GEL30. The U1, U6, U11, and U13 use the Laird TFLEX SF800. Samtec has 3D models, footprints, and schematic symbols for their connectors here:

<https://www.samtec.com/connectors/high-speed-board-to-board/high-density-arrays/searay>

Figure 16: Thermally Significant Components of Cisco ESS-3300-24T (Expansion Card)

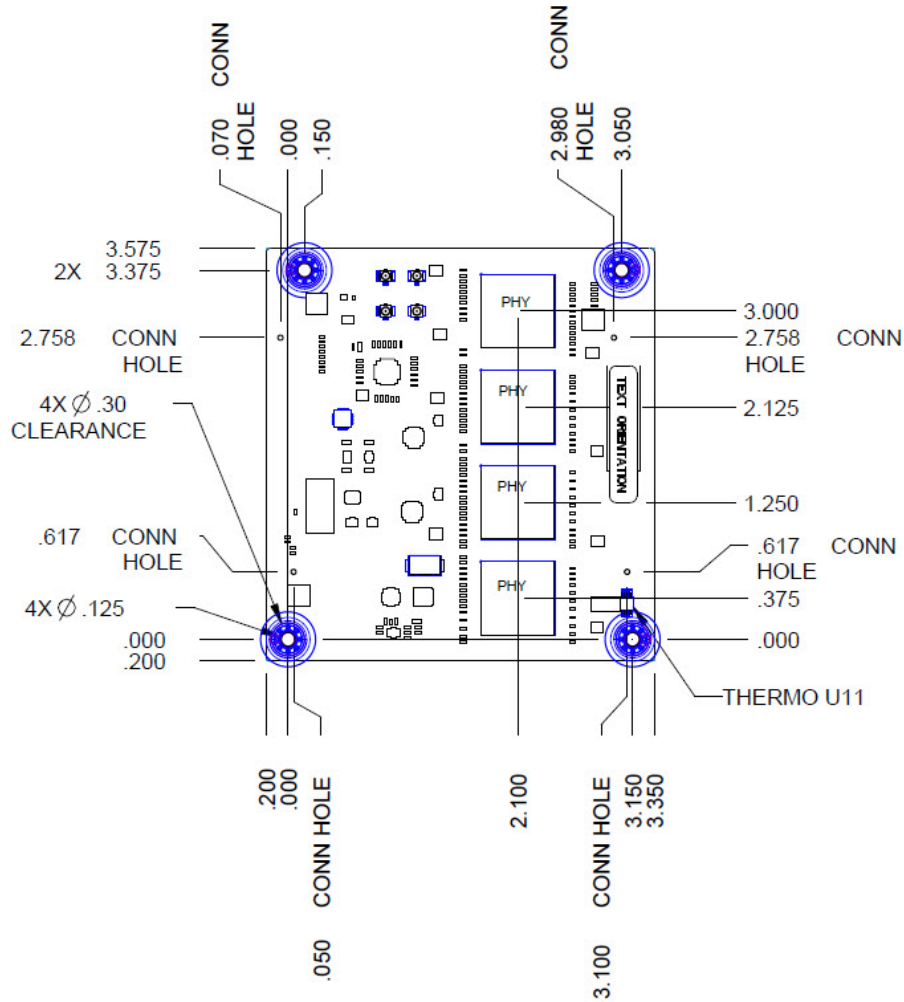

Table 7: Thermal Details for the Thermally Significant Components of Cisco ESS-3300-24T (Expansion Card)

RefDes	Thermal Design Power (in W)	Allowable junction temp (in degC)	Allowable case temp (in degC)	Package Characteristics		
				Package Type	Theta Jc (in degC/W)	Theta Jb (in degC/W)
U1,U3,U6,U7	1.5 each	110	—	FBGA256	13.6	16.45
U11	—	125	—	MSOP8	—	—



Note U43 is the Cisco ESS-3300-24T (Expansion Board) thermal sensor.

Validating a Thermal Solution

To validate a thermal solution, monitor the thermal sensor of the Cisco ESS 3300 cards in a thermal chamber set to the desired maximum ambient operating temperature and with traffic running.

Each card has a single sensor located near the center of the card, which makes contact with the thermal plate using thermal interface material. The temperature of the sensors should be less than 90.5C. The **show environment all** command can be executed from the IOS prompt to monitor the thermal sensor temperatures

```
Switch# show environment all
ALARM CONTACT 1
  Status:      not asserted
  Description: external alarm contact 1
  Severity:    minor
  Trigger:     closed
ALARM CONTACT 2
  Status:      not asserted
  Description: external alarm contact 2
  Severity:    minor
  Trigger:     closed
Supervisor Temperature Value: 51 C
Temperature State: GREEN
System Temperature thresholds
-----
Minor Threshold   : 80 C (Yellow)
Major Threshold   : 90 C (Red)
Critical Threshold : 96 C
Shutdown Threshold : 105 C
Pwr Supply        Type      Status
-----
POWER SUPPLY-A    DC       OK
POWER SUPPLY-B    DC       OK
SYSTEM TEMPERATURE is OK
System Temperature Value: 36 Degree Celsius
Extension Board Temperature Value: 32 Degree Celsius
```

Product Specifications

The following tables list the product specifications for the Cisco ESS 3300.

Table 8: Interface Support

ESS-3300	2 ports of 10 GE fiber, 24 ports of GE copper 4 of 8 GE ports can be combo ports on mainboard
ESS-3300-24T	2 ports of 10 GE fiber, 24 ports of GE copper 4 of 8 GE ports can be combo ports on mainboard 4 of 16 GE ports can be combo ports on expansion board

Table 9: Memory

DRAM	4GB
------	-----

SPI Flash	64MB
eMMC Flash	1.2GB (usable)

Table 10: Environmental

Industrial-grade components	-40degF to +185degF (-40degC to +85degC) component local ambient temperature specifications
Operating temperature	-40degF to +185degF (-40degC to +85degC) as measured at the center of the top surface of the –CON SKU thermal plate. Temperature range of a completed solution depends on the enclosure thermal design characteristics used by the integrator. If –NCP SKU is used, integrator is responsible for designing a thermal solution that meets the component level requirements provided in this document.
Non-Operating Temperature	-40degF to +185degF (-40degC to +85degC)
Operating altitude	15,000ft (4,572m)
Non-operating altitude	40,000ft (12,200m)
Humidity	95% +/- 5% RH

Table 11: Hardware Specifications

Hardware Specifications	+5Vdc (+/- 5%) and +3.3Vdc (+/- 3%)
Total Power	Thermal Power Main Board = 16W Thermal Power Main and Expansion Board = 22W Max Power Main Board = 17W Max Power Main and Expansion Board = 24W
Mass	ESS-3300-Main: 81 grams ESS-3300-Main with cooling plate: 178 grams ESS-3300-Expansion: 59 grams ESS-3300-Expansion with cooling plate: 159 grams
MTBF (Mean Time Before Failure)	ESS-3300 (-CON and –NCP) standalone Ground, Fixed, Controlled: 1,065,092 (in hours) ESS-3300-24T (-CON and –NCP) combined Ground, Fixed, Controlled: 919,768 (in hours)

Power Requirements

Both the Main Board and the Expansion Board require +5 VDC and +3.3 VDC to operate. The following table lists the DC power requirements for the Main Board and the Expansion Board.

The ESS-3300 can display a POWER GOOD status for two Power Inputs via the DC-A-GOOD and DC-B-GOOD signals. If these signals are not used, connect DC-A-GOOD to 3.3 V and DC-B-GOOD to ground.



Note There is no specific voltage sequence requirement for the 5V and 3.3V power inputs of the ESR. They can ramp up in any order.

Dying Gasp

In the case of a temporary power outage, the switch will send a Dying Gasp packet. If the power recovers, the switch will continue to operate normally.

Electrical Power Consumption

The following two tables show the power requirements.

Table 12: Power Requirements for the Main Board

Voltage Rail	Tolerance	Typical Current (A)	Maximum Current (A)
5V	+/- 3%	N/A	2.2
3.3V	+/- 3%	N/A	1.95
P3_3V RTC	+10% / -60%	400e-9	700e-9

Table 13: Power Requirements for the Expansion Board

Voltage Rail	Tolerance	Typical Current (A)	Maximum Current (A)
5V	+/- 3%	N/A	0.9
3.3V	+/- 3%	N/A	0.75

Power Over Ethernet (PoE)

The ESS-3300 supports IOS software control of PoE if the partner adds the appropriate circuitry to their host chassis. This is a chip to be integrated on the host motherboard, and is not an external power injector. Cisco uses the Microchip (formerly Microsemi) PD69208MILQ-TR-LE.

A maximum of 720W of power is supported through to PDs via the per port PSE controllers.



Note The actual amount of power available for POE may be less depending on size of the power supply included by the integrator.



Note Beginning with release 16.11.1, Cisco software started enforcing that the power bank must be set to 3 by hardware for PoE to turn on. Prior to release 16.11.1, software would let PoE turn on with any power bank setting, including Power Bank 1. The power bank should be set to 3 on all available PoE controllers (1-3).

Verify your setting through the **show controller power inline** CLI:

```
Switch#show controller power inline
Dragonite details
  Hardware version   : 0x4A02
  Product number    : 23
  Software version   : 02.1.1
  Parameter number   : 26
  Build number      : 1
  Internal SW number : 825

Dragonite System Status:
  poe controller error           : 0
  firmware download is required : 0
  poe controller memory error    : 0
  Factory Default                : 0
  General Internal Error         : 0
  Private_Label                  : 0x0
  User_Byte                      : 0xFF

PoE Device | Device Fail | Temperature Disconnect | Temperature Alarm
  1         | 0           | 0                       | 0
  2         | 1           | 0                       | 0
  3         | 1           | 0                       | 0

System Reset Status:
  Low Voltage Detect      : 0
  Lockup Exception       : 0
  Illegal Opcode         : 0
  Watchdog timer         : 0
  External Rest Pin      : 0
  Power on Reset         : 0

Reset_Info:
  Communication reset command : 0
  Clock recovery failure for more than 5sec : 0
  PoE Device failure          : 0
  I2C module was restarted    : 0
  Self reset                  : 0
  Save_Command_counter        : 0
```

```

Total Power details:
  Power Bank#           : 3
  Power Consumption[mW] : 4000
  Calculated Power[mW]  : 8000
  Available Power[mW]   : 92000
  Power Limit [mW]      : 100000
  Max Shutdown Voltage[mW] : 57000
  Min Shutdown Voltage[mW] : 44000
  Vmain Voltage[mV]     : 53800
  Imain Current[mA]     : 0

Port Data[8-1]:
Current State           : 1B 1B 1B 1B 1B 01 1B 1B
Port Enabled            : 01 01 01 01 01 01 01 01
Power delivering        : 00 00 00 00 00 01 00 00
Device class            : 00 00 00 00 00 02 00 00

```

The integrator should contact Cisco for any additional details.

SD Support

There is one Cisco SD card that has been tested and is recommended, the SD-IE-4GB. If the end user or system integrator chooses to use a 3rd party device, it may work for their application and to their satisfaction. However the end user or system integrator is solely responsible for testing and ensuring proper operation.

When a non Cisco SD card is installed, the following message appears:

```
WARNING: Non-IT SD flash detected. Use of this card during normal operation can impact and severely degrade performance of the system. Please use supported SD flash cards only.
```

You can find Cisco's policy on Third Party Components here:

https://www.cisco.com/c/en/us/products/warranties/warranty-doc-c99-740959.html#_Toc3320258

SFP Support

Both 100BASE-X and 1000BASE-X SFP transceivers are supported by the eight combo ports, four on the Main Board and four on the Expansion Board. The following table lists the specific SFP transceivers and their characteristics.



Important

The two SFP+ ports support only 10 GE SFP+ transceivers, and 1 GE SFP transceivers. 100 Mbps SFP transceivers are NOT supported on these two ports.



Note

The ESS-3300 has internal pull-ups on the I2C interfaces to the SFP. Recommend adding a weak (e.g. 100K) pull up to 3.3V on host board.

Supported SFP (plus marker) Modules

SFP	Distance	Fiber	Commercial(0C to 70C)	Extended(-5C to 85C)	Industrial(-40C to 85C)	DOM
SFP-10G-SR-X	2 km	MMF	—	X	—	—
SFP-10G-LR-X	10 km	SMF	—	X	—	—
SFP-10G-SR	2 km	MMF	X	—	—	—
SFP-10G-LR	10 km	SMF	X	—	—	—
SFP-10G-ER	40 km	SMF	X	—	—	—
SFP-10G-BXD-I	10 km	SMF	—	—	X	—
SFP-10G-BXU-I	10 km	SMF	—	—	X	—
SFP-10G-BX40D-I	40 km	SMF	—	—	X	—
SFP-10G-BX40U-I	40 km	SMF	—	—	X	—
SFP-H10G-CU1M	1 m	Passive Twinax	X	—	—	—
SFP-H10G-ACU7M		Active Twinax	X	—	—	—
SFP-H10G-ACU10M		Active Twinax	X	—	—	—

Supported SFP Modules

SFP	Distance	Fiber	Commercial(0C to 70C)	Extended(-5C to 85C)	Industrial(-40C to 85C)	DOM
GLC-SX-MM-RGD	220-550 m	MMF	—	—	X	—
GLC-LX-SM-RGD	550 m/10 km	MMF/SMF	—	—	X	—
GLC-ZX-SM-RGD	70 km	SMF	—	—	X	X
SFP-GE-S	220-550 m	MMF	—	X	—	X
SFP-GE-L	550 m/10 km	MMF/SMF	—	X	—	X
SFP-GE-Z	70 km	SMF	—	X	—	X
GLC-BX-U	10 km	SMF	X	—	—	X
GLC-BX-D	10 km	SMF	X	—	—	X
GLC-SX-MM	220-550 m	MMF	X	—	—	—

SFP	Distance	Fiber	Commercial(0C to 70C)	Extended(-5C to 85C)	Industrial(-40C to 85C)	DOM
GLC-LH-SM	550 m/10 km	MMF/SMF	X	—	—	—
GLC-ZX-SM	70 km	SMF	X	—	—	X
GLC-EX-SMD	40 km	SMF	X	—	—	X

Supported Fast Ethernet SFP Modules

SFP	Distance	Fiber	Commercial(0C to 70C)	Extended(-5C to 85C)	Industrial(-40C to 85C)	DOM
GLC-FE-100FX-RGD	2 km	MMF	—	—	X	—
GLC-FE-100LX-RGD	10 km	SMF	—	—	X	—
GLC-FE-100FX	2 km	MMF	X	—	—	—
GLC-FE-100LX	10 km	SMF	X	—	—	—
GLC-FE-100EX	40 km	SMF	X	—	—	—
GLC-FE-100ZX	80 km	SMF	X	—	—	—
GLC-FE-100BX-U	10 km	SMF	X	—	—	—
GLC-FE-100BX-D	10 km	SMF	X	—	—	—



CHAPTER 4

Device Zeroization and Recovery

This chapter contains the following sections:

- [Device Zeroization, on page 49](#)
- [Important Notice about Zeroization, on page 50](#)
- [Command Line Interface, on page 51](#)
- [Zeroization Trigger, on page 51](#)
- [Recovery Procedures, on page 52](#)

Device Zeroization

On the ESS-3300, the Push Button is used exclusively for triggering the Zeroization process which zeroize and erase switch configuration files or entire flash file system depending on the option provided under the CLI **service declassify**.

The Zeroization process starts as soon as the Push Button is pressed. The CLI command, **service declassify**, is used to set the desired action in response to the Push Button press. To prevent accidental erasure of the system configuration/image, the default setting is set to **no service declassify**.

eMMC is a managed NAND. This means that our embedded switch or router system does not interact with the flash memory directly. The flash controller presents a block-style interface to our system, and it handles the flash management (analogous to the Flash Translation Layer). Our embedded switch or router system cannot access the raw flash directly.

The JEDEC standard has commands that are supposed to remove data from the raw flash. In Cisco's implementation, the "Erase" and "Sanitize" commands are used. The eMMC standard JESD84-B51 defines "Sanitize" as follows:



Note The Sanitize operation is a feature that is used to remove data from the device according to Secure Removal Type. The use of the Sanitize operation requires the device to physically remove data from the unmapped user address space.



Note After the sanitize operation is completed, no data *should exist* in the unmapped host address space.



Important Zeroization does NOT erase removable media such as SD Card and USB Storage. This media must be removed from the system and erased or destroyed using procedures that are outside the scope of this document.

Important Notice about Zeroization



Caution Zeroize does a very thorough wipe of all non-protected parts of the eMMC flash using the best technology designed by the flash manufacturer today and can do so using the push of a button without the need for a console, ssh, or management session of any kind. It is the integrator's and end user's responsibility to determine the suitability regardless of the CLI keyword used to enable the feature.



Caution While Cisco IOS and Cisco IOS-XE use the command line text of “declassify” in the command line interface (CLI) to enable the zeroize feature, in no way does this represent any specific endorsement or acknowledgment of a Government approved flash erasure methodology.



Caution Declassification procedures are unique to each Government organization. Cisco solely provides the technical detail of the erasure operation here, not the policy distinction or any specific recommendation per classification.



Caution Please refer to your respective Government Agency policies, procedures, and recommendations for the handling of sensitive data to see if this procedure meets with those requirements.

WARNING!

The CLI **service declassify erase-all** is literally a **software self-destruct mechanism** intended for defense and intelligence environments that attempts to wipe clean, all of the writable non-volatile storage on the device to clear the device configuration, other stored configurations and all security credentials including any additional license keys.

Please do not use this feature in lieu of doing a **write erase** from the CLI or from the Administration page, Reload option of the WebUI. Invoke the reload with the **Reset to Factory Default and Reload** option and click **Apply**. See the following figure.

Administration > Reload

- Save Configuration and Reload.
- Reload without Saving Configuration.
- Reset to Factory Default and Reload.

Apply

If **service declassify erase-all** is invoked, after restoring the IOS-XE image and device configuration, you must re-license the device using the standard Cisco Smart Licensing procedures which ultimately require a Cisco Smart Account and access to the internet or a satellite license server.

Command Line Interface

There are two levels of Zeroization actions, erase-nvram and erase-all. The following CLI shows the options:

```
Switch(config)#service declassify ?
erase-nvram  Enable erasure of switch configuration as declassification action. Default
is no erasure.
erase-all    Enable erasure of both flash and nvram file systems as part of
declassification. Default is no erasure
```

The “erase-nvram” level of declassification process searches for the following files, and erases the ones found.

- flash:/nvram_config
- flash:/vlan.dat

This also erases the complete NVRAM filesystem, therefore, all configurations, including startup and running configurations will get deleted.

The perma-locked bootable image(s) in the flash file system will still be available and can be used for booting the device. See [Recovery Procedures, on page 52](#)

The “erase-all” level of Zeroization process erases the entire flash file system. This also wipes out all files and perma-locked bootable image(s). All interfaces are shut down before this process. Here, erasure of individual files in the flash file system is not possible and the only option is to erase the entire flash file system. This also erases packet data, ASIC data and processors related caches along with scrubbing Main memory.

With any level of Zeroization, the switch always fall back to the ROMMON prompt on the console after the erasure of configuration files or flash file system.

Zeroization Trigger

The user needs to press the Push Button after configuring the level of erasure required by the above CLI commands. To make sure that the Push Button press has been identified by underlying software, the user needs to press and hold it for ONE second, or at least till the zero LED starts blinking.

Recovery Procedures

Complete these steps in order to perform an emergency recovery:

Step 1 Boot the emergency install image.

Example:

```
switch: boot emgy0:<image-name>.SPA.bin
Booting golden bootloader...
Initializing disk drivers...
Initializing file systems...
*****
* Rom Monitor for ESS3300 *
* Copyright (c) 2017-2018 by Cisco Systems, Inc. *
* All rights reserved. *
*****
* Version: 1.1.1
* Compiled: Sun 01-Jul-18 22:17 [RELEASE SOFTWARE]
* Boot Partition: qspi-golden-bootloader
* Reset Reason: Soft Reset
Loading "emgy0:ess3x00-universalk9.16.09.01.SPA.bin" to memory...
Verifying image "emgy0:ess3x00-universalk9.16.09.01.SPA.bin"...
Image passed digital signature verification
Checking for Bootloader upgrade...
Bootloader upgrade not required
SUP PL (profile: 1) configuration done successfully
<...>
Press RETURN to get started!
Switch>
```

Step 2 Configure an IP address on the switch. Additional details on IP configuration can be found [here](#).

Example:

```
switch(config-if)#ip address <ip-address> <subnet-mask>
```

Step 3 Ping the terminal that contains the TFTP server in order to test the connectivity:

Example:

```
switch> ping 192.0.2.1
Type escape sequence to abort.
Sending 5, 100-byte ICMP Echoes to 192.0.2.1, timeout is 2 seconds:
!!!!
Success rate is 100 percent (5/5), round-trip min/avg/max = 1/2/4 ms
```

Step 4 Copy the image via tftp

Example:

```
switch> copy tftp://location/directory/bundle_name flash:<...>
```

Step 5 Restart the system.



CHAPTER 5

Secure Data Wipe

- [Enabling Secure Data Wipe, on page 53](#)

Enabling Secure Data Wipe

Secure data wipe is a Cisco wide initiative to ensure storage devices on all IOS XE based platforms are properly purged using NIST SP 800-88r1 compliant secure erase commands.

This feature is supported in Cisco IOS XE 17.10.1 and later on the following IoT switches for all license levels:

- IE3200
- IE3300
- IE3400
- IE3400H
- ESS3300

When secure data wipe is enabled, everything in internal flash memory is erased, including:

- User configuration and passwords
- Cisco IOS XE image
- Embedded MultiMediaCard (eMMC)
- rommon variables
- ACT2 Secure Storage



Note Secure erase does not clear the SD card or USB device contents. You must manually erase or reformat external storage devices.

The switch will be in rommon prompt with default factory settings (baud rate 9600) after the command is executed. The internal flash memory will not get formatted until the IOS image is rebooted.



Note If an sdflash/usbflash with a valid image inserted, the device will boot with the image in the external media based on the boot precedence. The device will be in rommon only if no external media with an image is inserted in the device.

Performing a Secure Data Wipe

To enable secure data wipe, enter the **factory-reset all secure** command in privileged exec mode, as shown in the following example:

```
Switch#factory-reset ?
  all          All factory reset operations
  keep-licensing-info  Keep license usage info
Switch#factory-reset all ?
secure  Securely reset all
Switch#factory-reset all secure
The factory reset operation is irreversible for securely reset all. Are you sure? [confirm]Y
```

factory-reset command options:

- **factory-reset all**—Remove everything from flash
- **factory-reset keep-licensing-info**—Keep the licensing information after factory reset and remove everything else from flash.
- **factory-reset all secure** —Remove everything from flash, and also unmount and sanitize the partitions before mounting back. This ensures that the data from those partitions cannot be recovered.



Important The **factory-reset all secure** operation may take hours. Please do not power cycle.

To check the log after the switch executes the command, boot up IOS XE and enter the following **show** command:

```
Switch#show platform software factory-reset secure log
Factory reset log:
#CISCO DATA SANITIZATION REPORT:# IE3200
Purge ACT2 chip at 12-08-2022, 15:17:28
ACT2 chip Purge done at 12-08-2022, 15:17:29
mtd and backup flash wipe start at 12-08-2022, 15:17:29
mtd and backup flash wipe done at 12-08-2022, 15:17:29.
```



CHAPTER 6

Appendix

This chapter contains the following sections:

- [Cisco Reference Design Port Map](#), on page 55
- [Web User Interface](#), on page 56
- [Compliance and Safety Information](#), on page 57
- [Restriction of Hazardous Substances \(RoHS\)](#), on page 58
- [Related Documentation](#), on page 58
- [Communications, Services, and Additional Information](#), on page 58

Cisco Reference Design Port Map

This section provides the port mapping relationship between the IOS XE interface name and the physical port.

Table 14: Port Mapping Relationship

IOS XE Interface Name	Reference Design Schematic Nets	Combo Port SFP Nets	PoE Controller Address	PoE Controller Port
Tel1/1	SFP_25			
Tel1/2	SFP_26			
Gi1/3	P3	SFP_3	1	2
Gi1/4	P4	SFP_4	1	3
Gi1/5	P1	SFP_1	1	0
Gi1/6	P2	SFP_2	1	1
Gi1/7	P7		1	6
Gi1/8	P8		1	7
Gi1/9	P5		1	4
Gi1/10	P6		1	5
Gi2/1	P11	SFP_11	2	2

IOS XE Interface Name	Reference Design Schematic Nets	Combo Port SFP Nets	PoE Controller Address	PoE Controller Port
Gi2/2	P12	SFP_12	2	3
Gi2/3	P9	SFP_9	2	0
Gi2/4	P10	SFP_10	2	1
Gi2/5	P15		2	6
Gi2/6	P16		2	7
Gi2/7	P13		2	4
Gi2/8	P14		2	5
Gi2/9	P19		3	2
Gi2/10	P20		3	3
Gi2/11	P17		3	0
Gi2/12	P18		3	1
Gi2/13	P23		3	6
Gi2/14	P24		3	7
Gi2/15	P21		3	4
Gi2/16	P22		3	5

Web User Interface

The Cisco IOS-XE operating system provides a graphical user interface for monitoring and configuration of your device. The WebUI needs to be enabled before it can be used. Use these commands to enable it:

```
username admin privilege 15 password 0 <password>
ip http server
ip http authentication local
ip http secure-server
```

When launched, the initial display is a dashboard that looks similar to the following example:

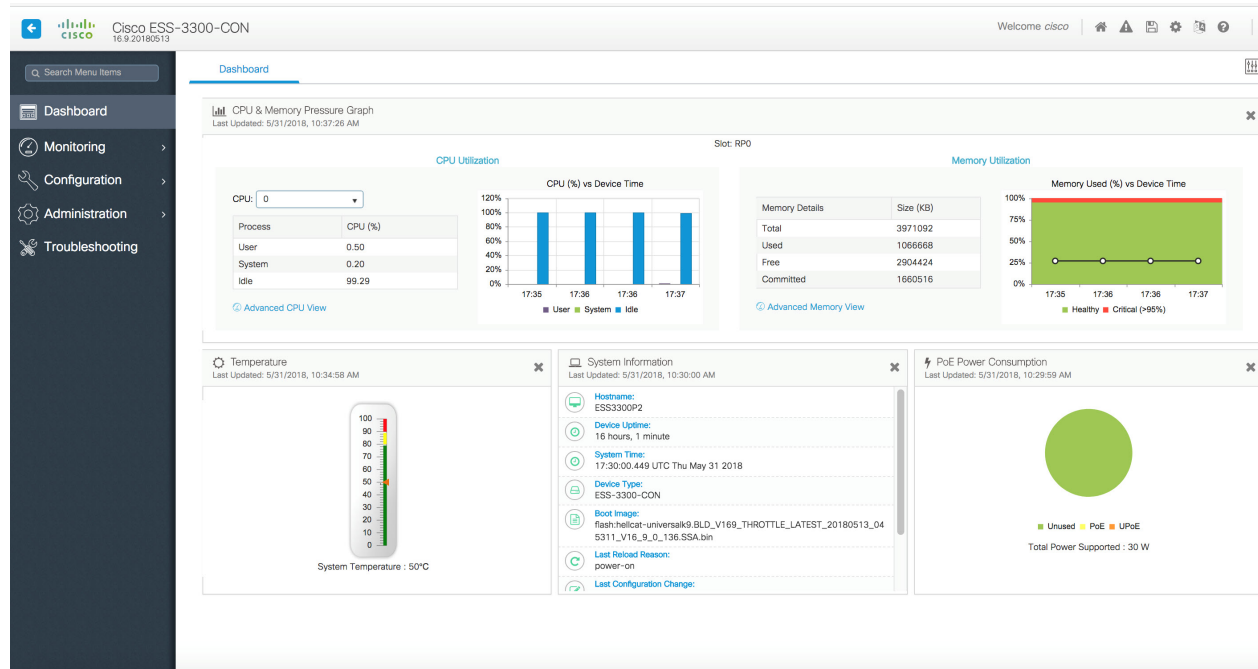

Compliance and Safety Information

The ESS 3300 and ESS 3300-16TC were installed in a representative chassis, tested, and shown to meet the standards listed in the following table. Individual results will depend on final implementation. Formal compliance testing must be performed by the integrator in a fully assembled product.

Specification	Description
Safety	<ul style="list-style-type: none"> • UL 60950-1 Recognized Component (R/C) • CSA22.2-No. 60950-1 • EN60950-1 • IEC60950-1
Emissions	<ul style="list-style-type: none"> • EN 55022 / CISPR 22 • EN 55032 / CISPR 32 • FCC Part 15 Subpart B • ICES 003 for class A device

Specification	Description
Immunity	<ul style="list-style-type: none"> • EN 55024 • EN 55035 • EN 61000-4-2 • EN 61000-4-3 • EN 61000-4-4 • EN 61000-4-5 • EN 61000-4-8 • EN 61000-4-16 • EN 61000-4-18

Restriction of Hazardous Substances (RoHS)

RoHS is directive being adopted worldwide that restricts certain limits of the following materials from certain manufactured products:

- Lead (Pb): < 1000 ppm
- Mercury (Hg): < 100 ppm
- Cadmium (Cd): < 100 ppm
- Hexavalent Chromium: (Cr VI) < 1000 ppm
- Polybrominated Biphenyls (PBB): < 1000 ppm
- Polybrominated Diphenyl Ethers (PBDE): < 1000 ppm

Related Documentation

[ESS3300 Product Landing Page](#)

[IoT Switching Configuration Guides](#)

[Cisco IOS XE 17.x](#)

Communications, Services, and Additional Information

- To receive timely, relevant information from Cisco, sign up at [Cisco Profile Manager](#).
- To get the business impact you're looking for with the technologies that matter, visit [Cisco Services](#).
- To submit a service request, visit [Cisco Support](#).
- To discover and browse secure, validated enterprise-class apps, products, solutions, and services, visit [Cisco DevNet](#).
- To obtain general networking, training, and certification titles, visit [Cisco Press](#).
- To find warranty information for a specific product or product family, access [Cisco Warranty Finder](#).

Cisco Bug Search Tool

[Cisco Bug Search Tool](#) (BST) is a gateway to the Cisco bug-tracking system, which maintains a comprehensive list of defects and vulnerabilities in Cisco products and software. The BST provides you with detailed defect information about your products and software.

Documentation Feedback

To provide feedback about Cisco technical documentation, use the feedback form available in the right pane of every online document.

