



# Cisco IE 3000 Switch Getting Started Guide

---

- [About This Guide, page 1](#)
- [Taking Out What You Need, page 2](#)
- [Connecting Expansion Modules, page 3](#)
- [Running Express Setup, page 5](#)
- [Managing the Switch, page 9](#)
- [Installing the Switch, page 11](#)
- [Connecting to the Switch Ports, page 21](#)
- [In Case of Difficulty, page 25](#)
- [Obtaining Documentation and Submitting a Service Request, page 28](#)
- [Cisco Five-Year Limited Hardware Warranty Terms, page 28](#)

## About This Guide

This guide provides instructions on how to use Express Setup to initially configure your Cisco IE 3000 switch. Also covered are switch management options, module connection procedures, basic mounting procedures, and troubleshooting help.

For additional installation and configuration information for Cisco IE 3000 switches, see the Cisco IE 3000 documentation on Cisco.com. For system requirements, important notes, limitations, open and resolved bugs, and last-minute documentation updates, see the release notes, also on Cisco.com.

When you use the online publications, refer to the documents that match the Cisco IOS software version running on the switch. The software version is on the Cisco IOS label on the switch rear panel.

For translations of the warnings that appear in this publication, see the *Regulatory Compliance and Safety Information for the Cisco IE 3000 Switch* that accompanies this guide.

## Taking Out What You Need

Follow these steps:

1. Unpack and remove the switch and the accessory kit from the shipping box.
2. Verify that you have received the items shown on page 3. If any item is missing or damaged, contact your Cisco representative or reseller for instructions.
3. Unpack and remove any optional expansion modules from their shipping boxes.
4. Return the packing material to the shipping containers, and save it for future use.



---

**Note**

For information about using the switch with the optional PWR-IE3000-AC power converter module, see the hardware installation guide on Cisco.com.

---

To rack-mount your switch, order the rack-mount adapter (STK-RACKMNT-2955=). This is not part of the switch accessory kit.

**Figure 1** Cisco IE 3000 Shipping Box Contents

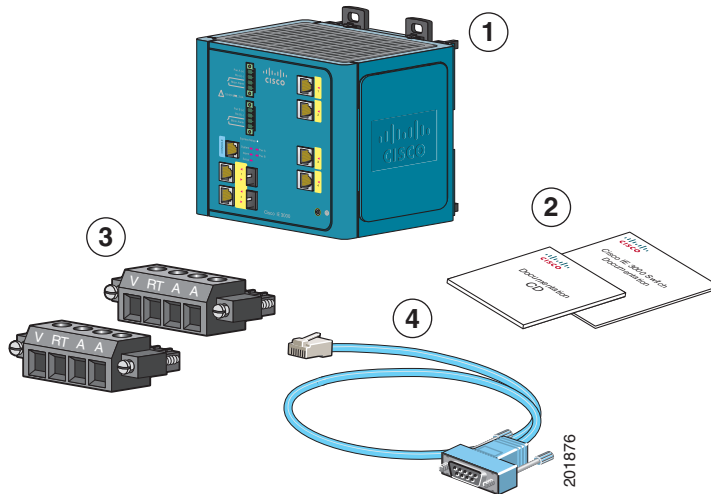

<b>1</b>	Cisco IE 3000 switch <sup>1</sup>	<b>3</b>	Power and relay connectors
<b>2</b>	Documentation	<b>4</b>	Console cable (RJ-45-to-DB-9 adapter cable)

1. The Cisco IE-3000-4TC is shown as an example. Your switch model might look different.

## Connecting Expansion Modules

The switch can operate as a standalone device with Fast Ethernet ports. You can increase the number of Fast Ethernet ports by connecting the Cisco IEM-3000-8TM or the Cisco IEM-3000-8FM expansion module. You can also install two expansion modules. Depending on the mix of switches and expansion modules, you can have up to 24 Fast Ethernet ports. For more information about the different combinations of the switch and expansion modules, see the *Cisco IE 3000 Switch Hardware Installation Guide* on Cisco.com.

The switch expansion modules are optional and do not ship with the switch. You need to order these separately.

Follow these steps to connect the expansion modules to the switch.

- Step 1** Remove the right side panel by firmly grasping both sides in the middle and pulling it outward. If necessary, use a flat-blade screwdriver to pry open the side panel.

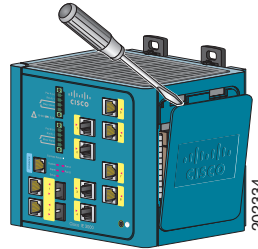

- Step 2** Remove the EMI protective cover from the connector.

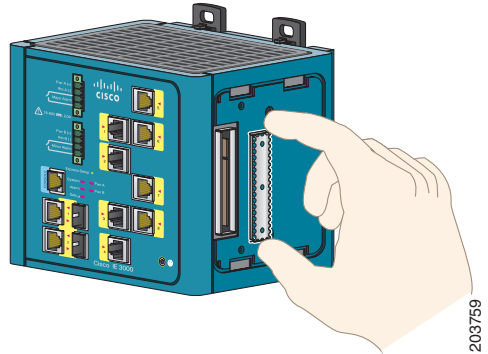

- Step 3** Push the upper module latches up and the lower module latches down, and then slide the switch and module together.



**Note** If you are installing a Cisco IEM-3000-8TM module and a Cisco IEM-3000-8FM module, install the Cisco IEM-3000-8TM first.

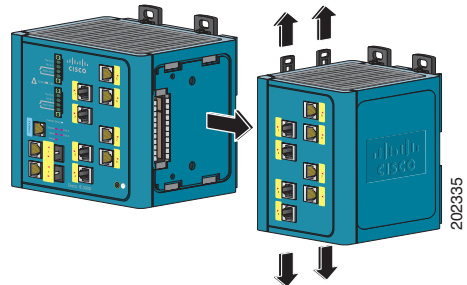

- Step 4** Push in the upper and lower module latches to secure the module to the switch.

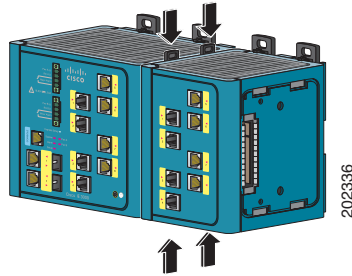

- Step 5** If you are installing a second module, repeat Step 2 to Step 3, but secure the second module to the right side of the first module.

## Running Express Setup

When you first set up the switch, you should use Express Setup to enter the initial IP information. Doing this enables the switch to connect to local routers and the Internet. You can then access the switch through the IP address for additional configuration.

You need this equipment to set up the switch:

- A PC with Windows 2000, Windows Vista, Windows 2003 or XP installed.
- A web browser (Internet Explorer 6.0, Internet Explorer 7.0, or Firefox 2.0) with JavaScript enabled.
- A straight-through Category 5 Ethernet cable to connect your PC to the switch.

Disable any pop-up blockers or proxy settings in your browser software and any wireless client running on your PC.

To run Express Setup:

- Step 1** Make sure that nothing is connected to the switch.
- During Express Setup, the switch acts as a DHCP server. If your PC has a static IP address, change your PC settings before you begin to temporarily use DHCP.

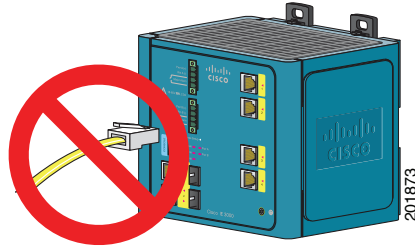

- Step 2** Connect power to the switch.

See the wiring instructions in the [“Grounding the Switch”](#) section on page 17 and the [“Wiring the DC Power Source”](#) section on page 18.

- Step 3** When the switch powers on, it begins the power-on self-test (POST). During POST, the System LED blinks while a series of tests verify that the switch functions properly. Wait for the switch to complete POST, which takes approximately 1 minute.

- Step 4** Make sure that POST has completed by verifying that the System LED is solid green. If the switch has not been configured, the Setup LED blinks green. If the Setup LED stops blinking, you can still continue with the next step.

If the switch fails POST, the System LED turns red. See the [“In Case of Difficulty”](#) section on page 25 if your switch fails POST.

- Step 5** Press the Express Setup button. This button is recessed behind the front panel, so you can use a simple tool, such as a paper clip.

When you press the Express Setup button, a switch port LED begins blinking green.

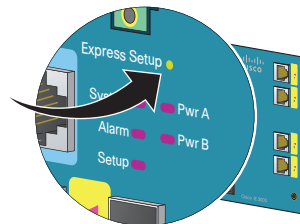

- Step 6** Connect a Category 5 Ethernet cable (not provided) from the blinking switch port to the Ethernet port on your PC.

The port LEDs on your PC and the switch blink green while the switch configures the connection.

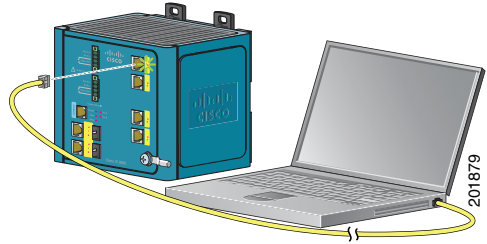

- Step 7** When the Setup LED turns solid green, start a browser session on the PC.

- Step 8** The Express Setup window automatically appears. If the window does not appear, verify that any proxy settings or pop-up blockers are disabled on your browser and that any wireless client is disabled on your PC. You might also need to enter a URL in your browser, such as *Cisco.com* or another well-known website. If you need help, see the [“In Case of Difficulty” section on page 25](#).



**Note** If the switch has been previously configured, the device manager page appears. You can use it to change the switch IP address.

**Network Settings**

Management Interface (VLAN):

IP Assignment Mode:  Static  DHCP

IP Address:  .  .  .  Subnet Mask:

Default Gateway:  .  .  .

Password:  Confirm Password:

---

**Optional Settings**

Host Name:

Telnet Access:  Enable  Disable

Telnet Password:  Confirm Telnet Password:

System Date (DD/MMM/YYYY):  /  /  System Time (HH:MM):  :  :

Time Zone:

Daylight Saving Time:  Enable

202341

- 
- Step 9** Enter the network settings. All entries must be in English letters and Arabic numbers.
- **Management Interface (VLAN):** We recommend using the default, **VLAN 1**. The management VLAN establishes an IP connection to the switch.
  - **IP Assignment Mode:** We recommend using the default, **Static**, which means that the switch always has the IP address that you assign. Use the **DHCP** setting when you want the switch to automatically obtain an IP address from a DHCP server.
  - **IP Address:** Enter the IP address for the switch. Later, you can use the IP address to access the switch through the device manager.
  - **Subnet Mask:** Select a mask from the drop-down list.
  - **Default Gateway:** Enter the IP address of the router.
  - **Password:** Enter a password. The password can be from 1 to 25 alphanumeric characters, can start with a number, is case sensitive, allows embedded spaces, but does not allow spaces at the beginning or end. In the **Confirm Password** field, enter the password again.

For more information about the network settings, click **Help** on the toolbar.

- 
- Step 10** Enter the **Optional Settings** now, or enter them later by using the device manager interface:
- Enter a **Host Name** for the switch.
  - Select **Enable** or **Disable** for Telnet access. If enabled, enter and confirm the Telnet password in the **Password** fields.
  - The date and time fields are populated from your PC.
  - Click **Enable** to use Daylight Saving Time.

For more information about the optional settings, click **Help** on the toolbar.

- 
- Step 11** Click **Submit** to save the information that you entered and to finish the basic configuration. You have completed the initial switch setup. If you click **Cancel**, the fields are cleared, and you can start over.

- 
- Step 12** Turn off DC power at the source, disconnect all cables to the switch, and install the switch in your network. See the [“Managing the Switch” section on page 9](#) for information about configuring and managing the switch.
-



## Refreshing the PC IP Address

After you complete Express Setup, you should refresh the PC IP address:

- For a dynamically assigned IP address, disconnect the PC from the switch, and reconnect the PC to the network. The network DHCP server assigns a new IP address to the PC.
- For a statically assigned IP address, change it to the previously configured IP address.

## Managing the Switch

After you complete Express Setup and install the switch in your network, use the device manager or other management options described in these sections for additional configuration:

- [Using the Device Manager, page 9](#)
- [Downloading Cisco Network Assistant, page 10](#)
- [Command-Line Interface, page 10](#)
- [Other Management Options, page 11](#)

## Using the Device Manager

The simplest way to manage the switch is by using the device manager that is in the Cisco IOS image. The device manager has a web interface that simplifies configuration and monitoring of the switch. You can access the device manager from anywhere in your network through a web browser.

Follow these steps:

1. Launch a web browser on your PC or workstation.
2. Enter the switch IP address in the web browser, and press **Enter**. The device manager page appears.

3. Use the device manager to perform basic switch configuration and monitoring. See the device manager online help for more information.
4. For more advanced configuration, download and run the Cisco Network Assistant, which is described in the next section.

## Downloading Cisco Network Assistant

Cisco Network Assistant is a software program that you download from Cisco.com and run on your PC. It offers advanced options for configuring and monitoring multiple devices, including switches, switch clusters, switch stacks, routers, and access points. Network Assistant is free—there is no charge to download, install, or use it.

Follow these steps:

1. Go to this Web address: <http://www.cisco.com/go/NetworkAssistant>.  
You must be a registered Cisco.com user, but you need no other access privileges.
2. Find the Network Assistant installer.
3. Download the Network Assistant installer, and run it. (You can run it directly from the Web if your browser offers this choice.)
4. When you run the installer, follow the displayed instructions. In the final panel, click **Finish** to complete the Network Assistant installation.

See the Network Assistant online help and the getting started guide for more information.

## Command-Line Interface

You can manage the switch from the command-line interface (CLI) by connecting your PC directly to the switch console port or to an Ethernet port. This procedure explains how to access the CLI through the console port.

## Using the Switch Console Port:

Follow these steps:

1. Connect the supplied RJ-45-to-DB-9 adapter cable (console cable) to the standard 9-pin serial port on the PC. Connect the other end of the cable to the console port on the switch.
2. Start a terminal-emulation program on the PC.
3. Configure the PC terminal emulation software for 9600 bits per second, 8 data bits, no parity, 1 stop bit, and no flow control.

Use the CLI to enter commands to configure the switch. See the software configuration guide and the command reference for more information.

## Other Management Options

You can use Simple Network Management Protocol (SNMP) management applications such as CiscoWorks Small Network Management Solution (SNMS) and HP OpenView to configure and manage the switch. You also can manage it from an SNMP-compatible workstation that is running platforms such as HP OpenView or SunNet Manager.

See the [“Accessing Online Help”](#) section on page 27 for a list of supporting documents.

## Installing the Switch

These sections explain how to install the switch on a DIN rail or in a rack. Refer to the switch hardware guide for instructions on mounting the switch on a wall:

- [Equipment That You Supply](#), page 12
- [Before You Begin](#), page 12
- [Installation Warning Statements](#), page 13
- [Mounting the Switch to a DIN Rail or to the Rack Adapter](#), page 16
- [Grounding the Switch](#), page 17
- [Wiring the DC Power Source](#), page 18

- [Attaching the Power and Relay Connector, page 20](#)
- [Optional Procedures, page 21](#)

## Equipment That You Supply

Obtain these necessary tools and equipment:

- Ratcheting torque flathead screwdriver that exerts up to 15-inch pound (in-lb) of pressure
- Ring terminal lug (such as Thomas & Bett part number 10RC6 or equivalent)
- Crimping tool (such as Thomas & Bett part number WT2000, ERG-2001, or equivalent)
- 10- to 12-gauge copper ground wire (such as Belden part number 9912 or equivalent)
- For DC power connections, use UL- and CSA-rated style 1007 or 1569 twisted-pair copper appliance wiring material (AWM) wire (such as Belden part number 9318)
- Wire-stripping tools for stripping 10-, 12-, and 18-gauge wires
- For rack-mounting, a number-2 Phillips screwdriver
- A flat-blade screwdriver

## Before You Begin

When you determine where to install the switch, verify that these guidelines are met:

- Operating environment is within the range in the switch hardware installation guide.
- Clearance to front and rear panels meets these conditions:
  - Front-panel LEDs can be easily read.
  - Access to ports is sufficient for unrestricted cabling.
  - Front-panel direct current (DC) power and relay connector is within reach of the connection to the DC power source.

- Airflow around the switch and through the vents is unrestricted. To prevent the switch from overheating, these must be the minimum clearances:
  - Top and bottom: 4.13 in. (105 mm)
  - Left and right: 3.54 in. (90 mm)
  - Front: 2.56 in. (65 mm)
- Temperature surrounding the unit does not exceed 140°F (60°C), the maximum ambient temperature of the switch.

**Note**

---

When the switch is installed in an industrial enclosure, the temperature within the enclosure is greater than normal room temperature outside the enclosure.

---

- Cabling is away from sources of electrical noise, such as radios, power lines, and fluorescent lighting fixtures.
- This product is grounded to a bare metal surface, such as a ground bus, a grounded DIN rail, or a grounded bare rack. Use a zinc-plated, yellow-chromate steel DIN rail to assure proper grounding. The use of other materials (such as aluminum, plastic, and so on) that can corrode, oxidize, or are poor conductors can result in improper or intermittent grounding. When grounding to a DIN rail, secure the DIN rail to the mounting surface approximately every 7.8 in. (200 mm), and use appropriate end-anchors.

## Installation Warning Statements

**Warning**

---

**Before performing any of the following procedures, ensure that power is removed from the DC circuit.** Statement 1003

---

**Warning**

---

**This product relies on the building's installation for short-circuit (overcurrent) protection. Ensure that the protective device is rated not greater than: 5A.** Statement 1005

---



**Warning**

**This unit is intended for installation in restricted access areas. A restricted access area can be accessed only through the use of a special tool, lock and key, or other means of security.** Statement 1017



**Warning**

**This equipment must be grounded. Never defeat the ground conductor or operate the equipment in the absence of a suitably installed ground conductor. Contact the appropriate electrical inspection authority or an electrician if you are uncertain that suitable grounding is available.** Statement 1024



**Warning**

**Only trained and qualified personnel should be allowed to install, replace, or service this equipment.** Statement 1030



**Warning**

**To prevent the system from overheating, do not operate it in an area that exceeds the maximum recommended ambient temperature of: 140°F (60°C)** Statement 1047



**Warning**

**This equipment is supplied as “open type” equipment. It must be mounted within an enclosure that is suitably designed for those specific environmental conditions that will be present and appropriately designed to prevent personal injury resulting from accessibility to live parts. The interior of the enclosure must be accessible only by the use of a tool.**

**The enclosure must meet IP 54 or NEMA type 4 minimum enclosure rating standards.** Statement 1063



**Warning**

**This equipment is intended to be grounded to comply with emission and immunity requirements. Ensure that the switch functional ground lug is connected to earth ground during normal use.** Statement 1064



**Warning**

---

**When used in a Class I, Division 2, hazardous location, this equipment must be mounted in a suitable enclosure with proper wiring method, for all power, input and output wiring, that complies with the governing electrical codes and in accordance with the authority having jurisdiction over Class I, Division 2 installations.** Statement 1066

---



**Warning**

---

**To prevent airflow restriction, allow clearance around the ventilation openings to be at least: 4.13 in. (10.5 cm)** Statement 1076

---



**Caution**

---

This equipment is suitable for use in Class I, Division 2, Groups A, B, C, D, or only nonhazardous locations.

---



**Caution**

---

Connect the unit only to a Class 2 DC power source.

---

## Mounting the Switch to a DIN Rail or to the Rack Adapter

Follow these steps to mount the switch on a DIN rail or in a rack.

- Step 1** If you are mounting the switch in a rack, first secure the Cisco IE 3000 rack adapter to the rack.  
If mounting on a DIN rail, omit this step.

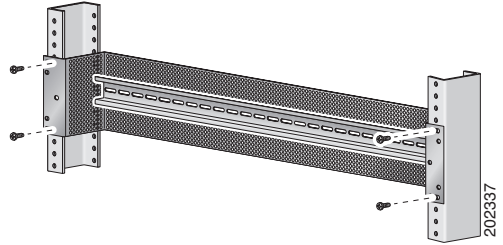

- Step 2** Insert a flat-head screwdriver in the space next to the tab, and turn the screw driver to release the latch and push it out.

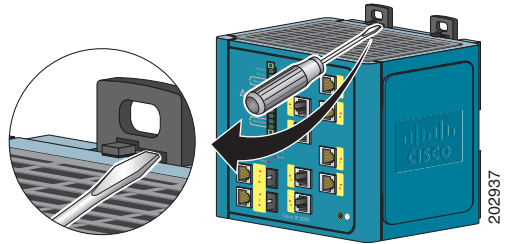

- Step 3** If you are using a 15 mm DIN rail, rotate all feet to the extended positions. Otherwise, rotate the feet to the recessed positions.

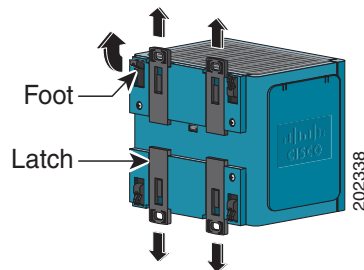



- Step 4** Position the rear panel of the switch directly in front of the DIN rail, making sure that the DIN rail fits in the space between the two latches.

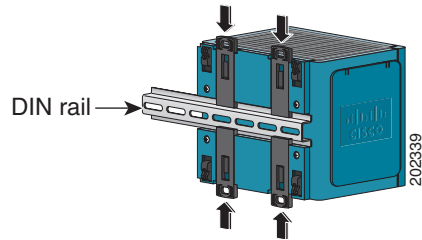

- Step 5** Push the DIN rail latches in after the switch is over the DIN rail to secure the switch to the rail. You hear a click when the latches are completely locked.

- Step 6** Connect power to the switch.

See the wiring instructions in the [“Grounding the Switch”](#) section on page 17 and the [“Wiring the DC Power Source”](#) section on page 18.

## Grounding the Switch

Follow these steps to connect the switch to a protective ground.



### Warning

**This equipment must be grounded. Never defeat the ground conductor or operate the equipment in the absence of a suitably installed ground conductor. Contact the appropriate electrical inspection authority or an electrician if you are uncertain that suitable grounding is available.** Statement 1024

- Step 1** Use a standard Phillips screwdriver or a ratcheting torque screwdriver with a Phillips head to remove the ground screw from the front panel of the switch. Store the ground screw for later use.

- Step 2** Use a wire stripping tool to strip the 10- to 12-gauge ground wire to 0.5 inch (12.7 mm)  $\pm$  0.02 inch (0.5 mm).

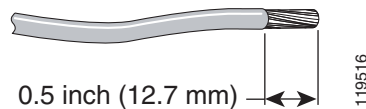

- Step 3** Insert the ground wire into the ring terminal lug, and using a crimping tool, crimp the ring terminal to the wire.

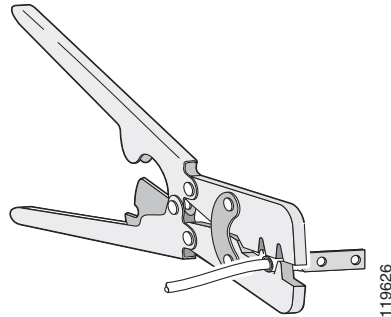

- Step 4** Slide the ground screw from Step 1 through the ring terminal.

- Step 5** Insert the ground screw into the ground-screw opening on the front panel.

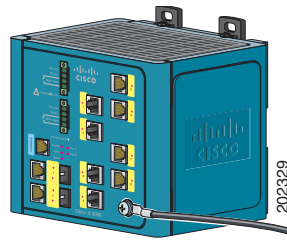

- Step 6** Use a ratcheting torque screwdriver to tighten the ground screw and ring terminal lug to the switch front panel to 8.5 in-lb, the maximum recommended torque.

- Step 7** Attach the other end of the ground wire to a grounded bare metal surface, such as a ground bus, a grounded DIN rail, or a grounded bare rack.

## Wiring the DC Power Source

Follow these steps to prepare the DC power cable.



**Warning**

**Before performing any of the following procedures, ensure that power is removed from the DC circuit.** Statement 1003



**Warning**

**This product relies on the building's installation for short-circuit (overcurrent) protection. Ensure that the protective device is rated not greater than: 5A.**

Statement 1005

**Warning**

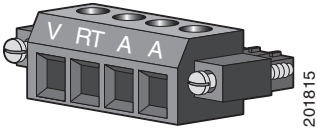
**Only trained and qualified personnel should be allowed to install, replace, or service this equipment.** Statement 1030

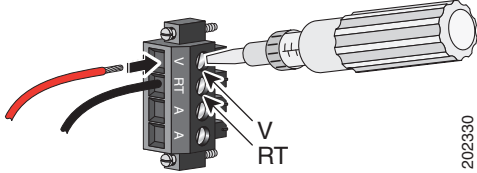
<b>Step 1</b>	Locate the power and relay connector.	
<b>Step 2</b>	Identify the positive and return DC power connections on the connector. The positive DC power connection is labeled V, and the return is the adjacent connection labeled RT.	
<b>Step 3</b>	Measure a strand of twisted-pair copper wire (18- to 20-AWG) long enough to connect to the DC power source.	
<b>Step 4</b>	Using an 18-gauge wire-stripping tool, strip each of the two wires to 0.25 inch (6.3 mm) $\pm$ 0.02 inch (0.5 mm). Do not strip more than 0.27 inch (6.8 mm) of insulation from the wire. Stripping more than the recommended amount of wire can leave exposed wire from the connector after installation.	
<b>Step 5</b>	Insert the exposed part of the positive wire into the connection labeled V and the exposed part of the return wire into the connection labeled RT. Make sure that you cannot see any wire lead. Only wire <i>with insulation</i> should extend from the connector.	
<b>Step 6</b>	Use a ratcheting torque flathead screwdriver to torque the power and relay connector captive screws (above the installed wire leads) to 2 in-lb, the maximum recommended torque.	

- Step 7** Connect the other end of the positive wire (the one connected to V) to the positive terminal on the DC power source, and connect the other end of the return wire (the one connected to RT) to the return terminal on the DC power source.
- Step 8** When you are testing the switch, one power connection is sufficient. If you are installing the switch and are using a second power source, repeat Step 3 through Step 7 using a second power and relay connector.

## Attaching the Power and Relay Connector

Follow these steps to connect the DC power and relay connector to the switch:



### Caution

The input voltage source of the alarm circuits must be an isolated source and limited to less than or equal to 30 VDC, 1 A.

- Step 1** Insert the power and relay connector into the Pwr A receptacle on the switch front panel.

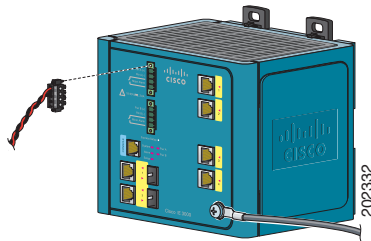

- Step 2** Use a flathead screwdriver to tighten the captive screws on the sides of the power and relay connector.

- Step 3** Optionally, insert a second power and relay connector into the Pwr B receptacle on the switch front panel.

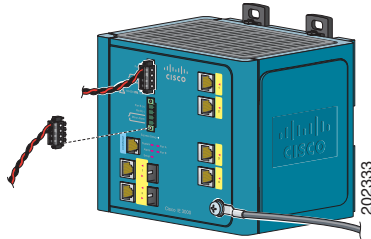

- Step 4** Use a flathead screwdriver to tighten the captive screws on the sides of the second power and relay connector.

## Optional Procedures

For detailed instructions on these procedures, see the *Cisco IE 3000 Switch Hardware Installation Guide* on Cisco.com.

- Wiring the external alarm relays
- Connecting the switch to the optional PWR-IE3000-AC power converter
- Mounting the switch on the wall
- Installation in a hazardous environment

## Connecting to the Switch Ports

These sections describe how to connect to the switch ports, the SFP module ports, and the dual-purpose ports. For additional cabling information, see the *Cisco IE 3000 Switch Hardware Installation Guide* on Cisco.com.

- [Connecting to 10/100 and 10/100/1000 Ports, page 22](#)
- [Installing SFP Modules and Connecting to Ports, page 23](#)
- [Connecting to Dual-Purpose Ports, page 24](#)
- [Connecting to 100BASE-FX Ports, page 24](#)
- [Verifying Port Connectivity, page 24](#)

## Connecting to 10/100 and 10/100/1000 Ports

Follow these steps:

- Step 1** When you connect these switches to any Ethernet-enabled communication devices, insert a straight-through twisted four-pair, Category 5 cable in a switch 10/100 or 10/100/1000 port. Use a twisted four-pair, Category 5 cable when you connect to other switches, hubs, or repeaters.

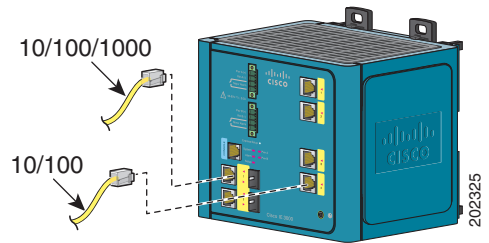

- Step 2** Insert the other cable end into an RJ-45 connector on the other device.

For simplified cabling, the automatic medium-dependent interface crossover (auto-MDIX) feature is enabled by default on the switch. With auto-MDIX enabled, the switch detects the required cable type for copper Ethernet connections and configures the interfaces accordingly. Therefore, you can use either a crossover or a straight-through cable for connections to a switch 10/100 or 10/100/1000 Ethernet port, regardless of the type of device on the other end of the connection.

## Installing SFP Modules and Connecting to Ports

Follow these steps:

- Step 1** Grasp the module on the sides, and insert it into the switch slot until you feel the connector snap into place.

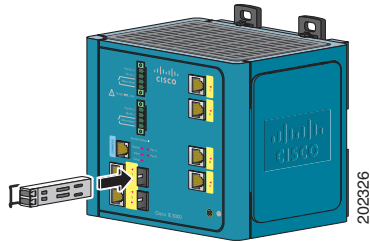

- Step 2** Insert an appropriate cable into the module port.

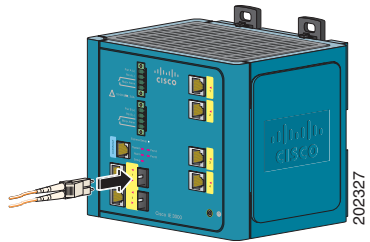

- Step 3** Insert the other cable end into the other device.

For a list of supported modules, see the release notes on Cisco.com. For detailed instructions on installing, removing, and connecting to SFP modules, see the documentation that came with the SFP module.



### Caution

Removing and installing an SFP module can shorten its useful life. Do not remove and insert SFP modules more often than is absolutely necessary.

## Connecting to Dual-Purpose Ports

Only one port on a dual-purpose port can be active at a time. If both ports are connected, the SFP module port has priority.

Follow these steps:

- 
- Step 1** Insert either an RJ-45 connector to the 10/100/1000 port (see the [“Connecting to 10/100 and 10/100/1000 Ports” section on page 22](#)), or install an SFP module into the SFP module slot, and connect a cable to the SFP module port. (See the [“Installing SFP Modules and Connecting to Ports” section on page 23](#).)
- 
- Step 2** Insert the other cable end into the other device.
- 

## Connecting to 100BASE-FX Ports

Follow these steps:

- 
- Step 1** Insert an LC cable into the 100BASE-FX port of a Cisco IEM-3000-8FM expansion module.

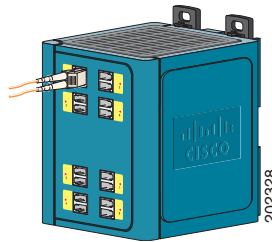

- 
- Step 2** Insert the other cable end into the other device.
- 

## Verifying Port Connectivity

After you connect to the switch port and another device, the port LED turns amber while the switch establishes a link. This process takes about 30 seconds, and then the LED turns green when the switch and the target device have an established link. If the LED is off, the target device might not be turned on, there might be a cable problem, or there might be a problem with the adapter installed in the target device.



## In Case of Difficulty

See these sections if you have difficulty setting up your switch:

- [Troubleshooting Express Setup, page 25](#)
- [Resetting the Switch, page 26](#)
- [Accessing Online Help, page 27](#)
- [For More Information, page 27](#)

## Troubleshooting Express Setup

Help with the initial switch configuration is provided here. For additional assistance, see the online documentation at [Cisco.com](http://Cisco.com).

Checklist	Recommendation
Was the SETUP LED blinking when you pressed the Express Setup button?	If no, or you are not sure, restart the switch. Make sure that the SETUP LED is blinking when you press the Express Setup button.
Did you connect your PC to the wrong switch port?	Verify that you are connected to the switch port with the blinking LED.
Did you start a browser session on your PC before the SETUP LED was solid green?	If yes, or you are not sure, restart the switch, and repeat the Express Setup procedure.
Did you start a browser session on your PC and the set-up page did not appear?	If the window does not appear, enter a URL in your browser, such as <i>Cisco.com</i> or another well-known website.
Did you have a pop-up blocker running on your PC when you connected to the switch port?	If yes, disconnect the cable from the switch port, disable the pop-up blocker, press the Express Setup button, and reconnect the cable to the blinking Ethernet port.
Did you have proxy settings enabled in your browser software when you connected to the switch port?	If yes, disconnect the cable from the switch port, disable the proxy settings, press the Express Setup button, and reconnect the cable to the blinking Ethernet port.

Checklist	Recommendation
Did you have a wireless client running on your PC when you connected to the switch port?	If yes, disconnect the cable from the switch port, disable the wireless client, press the Express Setup button, and reconnect the cable to the blinking Ethernet port.
Do you need to change the switch IP address after you have already completed the initial setup?	Go to the <b>Configure &gt; Express Setup</b> device manager screen to change the switch IP address. For more information about changing the switch IP address, see the switch configuration guide online at Cisco.com.

## Resetting the Switch

Follow these steps to return your switch to the factory default settings. These are reasons why you might want to reset the switch:

- You installed the switch in your network and cannot connect to it because you assigned the wrong IP address.
- You want to clear all configurations from the switch and assign a new IP address.
- You want to reset the password on the switch.



### Caution

Resetting the switch deletes the configuration and reboots the switch.

To reset the password on the switch:

1. Power off the switch.
2. Power on the switch, and at the same time, press and hold down the Express Setup button until all the system LEDs turn red.
3. Release the Express Setup button, and the switch continues to boot.

After the switch restarts, continue to run Express Setup.

## Accessing Online Help

First look for a solution to your problem in the troubleshooting section of the switch hardware installation guide or the switch software configuration guide on Cisco.com. You can also access the Cisco Technical Support and Documentation website for a list of known hardware problems and extensive troubleshooting documentation.

## For More Information

For more information about the switch, see these documents on Cisco.com:

- *Cisco IE 3000 Switch Hardware Installation Guide*. This guide provides complete hardware descriptions and detailed installation procedures.
- *Regulatory Compliance and Safety Information for the Cisco IE 3000 Switch*. This guide contains agency approvals, compliance information, and translated warning statements.
- *Release Notes for the Cisco IE 3000 Switch*.
- *Cisco IE 3000 Switch Software Configuration Guide*. This guide provides a product overview and detailed descriptions and procedures of the switch software features.
- *Cisco IE 3000 Switch Command Reference*. This reference provides detailed descriptions of the Cisco IOS commands specifically created or modified for the switch.
- *Cisco IE 3000 Switch System Message Guide*. This guide provides descriptions of the system messages specifically created or modified for the switch.
- Device manager online help (available on the switch).
- *Cisco Small Form-Factor Pluggable Modules Installation Notes*.

# Obtaining Documentation and Submitting a Service Request

For information on obtaining documentation, submitting a service request, and gathering additional information, see the monthly *What's New in Cisco Product Documentation*, which also lists all new and revised Cisco technical documentation, at:

<http://www.cisco.com/en/US/docs/general/whatsnew/whatsnew.html>

Subscribe to the *What's New in Cisco Product Documentation* as a Really Simple Syndication (RSS) feed and set content to be delivered directly to your desktop using a reader application. The RSS feeds are a free service and Cisco currently supports RSS version 2.0.

## Cisco Five-Year Limited Hardware Warranty Terms

There are special terms applicable to your hardware warranty and various services that you can use during the warranty period. Your formal Warranty Statement, including the warranties and license agreements applicable to Cisco software, is available at <http://www.cisco.com/go/warranty>

You can also contact the Cisco service and support website at [http://www.cisco.com/public/Support\\_root.shtml](http://www.cisco.com/public/Support_root.shtml).

### **Duration of Hardware Warranty**

Five (5) Years

### **Replacement, Repair, or Refund Policy for Hardware**

Cisco or its service center will use commercially reasonable efforts to ship a replacement part within ten (10) working days after receipt of a Return Materials Authorization (RMA) request. Actual delivery times can vary, depending on the customer location.

Cisco reserves the right to refund the purchase price as its exclusive warranty remedy.

**To Receive a Return Materials Authorization (RMA) Number**

Contact the company from whom you purchased the product. If you purchased the product directly from Cisco, contact your Cisco Sales and Service Representative.

Complete the information below, and keep it for reference.

Company product purchased from	
Company telephone number	
Product model number	
Product serial number	
Maintenance contract number	



CCDE, CCENT, Cisco Eos, Cisco Lumin, Cisco StadiumVision, the Cisco logo, DCE, and Welcome to the Human Network are trademarks; Changing the Way We Work, Live, Play, and Learn is a service mark; and Access Registrar, Aironet, AsyncOS, Bringing the Meeting To You, Catalyst, CCDA, CCDP, CCIE, CCIP, CCNA, CCNP, CCSP, CCVP, Cisco, the Cisco Certified Internetwork Expert logo, Cisco IOS, Cisco Press, Cisco Systems, Cisco Systems Capital, the Cisco Systems logo, Cisco Unity, Collaboration Without Limitation, EtherFast, EtherSwitch, Event Center, Fast Step, Follow Me Browsing, FormShare, GigaDrive, HomeLink, Internet Quotient, IOS, iPhone, iQ Expertise, the iQ logo, iQ Net Readiness Scorecard, iQuick Study, IronPort, the IronPort logo, LightStream, Linksys, MediaTone, MeetingPlace, MGX, Networkers, Networking Academy, Network Registrar, PCNow, PIX, PowerPanels, ProConnect, ScriptShare, SenderBase, SMARTnet, Spectrum Expert, StackWise, The Fastest Way to Increase Your Internet Quotient, TransPath, WebEx, and the WebEx logo are registered trademarks of Cisco Systems, Inc. and/or its affiliates in the United States and certain other countries.

All other trademarks mentioned in this document or Website are the property of their respective owners. The use of the word partner does not imply a partnership relationship between Cisco and any other company. (0804R)

Any Internet Protocol (IP) addresses used in this document are not intended to be actual addresses. Any examples, command display output, and figures included in the document are shown for illustrative purposes only. Any use of actual IP addresses in illustrative content is unintentional and coincidental.

