



CHAPTER 17

Configuring IP Unnumbered Interface

This chapter discusses the IP Unnumbered Interface feature, which allows you to enable IP processing on an interface without assigning an explicit IP address.

This chapter contains these sections:

- [About IP Unnumbered Interface Support, page 17-1](#)
- [IP Unnumbered Configuration Guidelines and Restrictions, page 17-3](#)
- [Configuring IP Unnumbered Interface Support with DHCP Server, page 17-4](#)
- [Configuring IP Unnumbered Interface Support with Connected Host Polling, page 17-6](#)
- [Displaying IP Unnumbered Interface Settings, page 17-7](#)
- [Troubleshooting IP Unnumbered Interface, page 17-8](#)
- [Related Documents, page 17-8](#)



Note

For complete syntax and usage information for the switch commands used in this chapter, see the *Cisco Catalyst 4500 Series Switch Command Reference* and related publications at this location:

<http://www.cisco.com/en/US/products/hw/switches/ps4324/index.html>

If a command is not in the *Catalyst 4500 Series Switch Command Reference*, you can locate it in the Cisco IOS library. See the *Cisco IOS Command Reference* and related publications at this location:

<http://www.cisco.com/en/US/products/ps6350/index.html>

About IP Unnumbered Interface Support

Before you configure VLANs and LAN interfaces with IP unnumbered interfaces, you should understand the following concepts:

- [IP Unnumbered Interface Support with DHCP Server and Relay Agent, page 17-2](#)
- [DHCP Option 82, page 17-2](#)
- [IP Unnumbered Interface with Connected Host Polling, page 17-3](#)

IP Unnumbered Interface Support with DHCP Server and Relay Agent

The IP unnumbered interface configuration allows you to enable IP processing on an interface without assigning it an explicit IP address. The IP unnumbered interface can “borrow” the IP address from another interface that is already configured on the Catalyst 4500 series switch, which conserves network and address space. When used with the DHCP server/relay agent, this feature allows a host address assigned by the DHCP server to be learned dynamically at the DHCP relay agent.

Figure 17-1 shows a sample network topology implementing the IP Unnumbered Interface feature. In this topology, IP routes are dynamically established by the aggregation switch when the DHCP server assigns IP addresses to the hosts.

Figure 17-1 Sample Network Topology Using the VLANs over IP Unnumbered Interfaces Feature

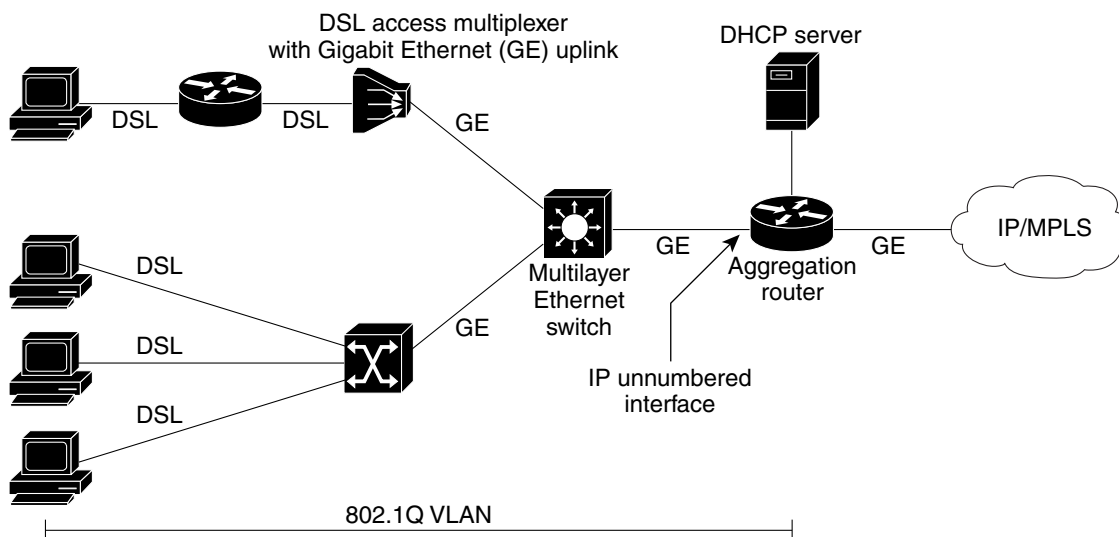

95961

DHCP Option 82

DHCP provides a framework for passing configuration information to hosts on a TCP/IP network. Configuration parameters and other control information are carried in tagged data items that are stored in the options field of the DHCP message. The data items are also called *options*. Option 82 is organized as a single DHCP option that contains information known by the relay agent.

The IP Unnumbered Interface feature communicates information to the DHCP server using a suboption of the DHCP relay agent information option called *agent remote ID*. The information sent in the agent remote ID includes an IP address identifying the relay agent and information about the interface and the connection over which the DHCP request entered. The DHCP server can use this information to make IP address assignments and security policy decisions.

Figure 17-2 shows the agent remote ID suboption format that is used with the IP Unnumbered Interfaces feature.

Figure 17-2 Format of the Agent Remote ID Suboption

Table 17-1 describes the agent remote ID suboption fields displayed in Figure 17-2.

Table 17-1 Agent Remote ID Suboption Field Descriptions

Field	Description
Type	Format type. The value 2 specifies the format for use with this feature. (1 byte)
Length	Length of the Agent Remote ID suboption, not including the type and length fields. (1 byte)
Reserved	Reserved. (2 bytes)
NAS IP Address	IP address of the interface specified by the ip unnumbered command. (4 bytes)
Interface	Physical interface. This field has the following format: slot (4 bits) module (1 bit) port (3 bits). For example, if the interface name is interface ethernet 2/1/1, the slot is 2, the module is 1, and the port is 1. (1 byte)
Reserved	Reserved. (1 byte)
VLAN ID	VLAN identifier for the Ethernet interface. (2 bytes)

IP Unnumbered Interface with Connected Host Polling

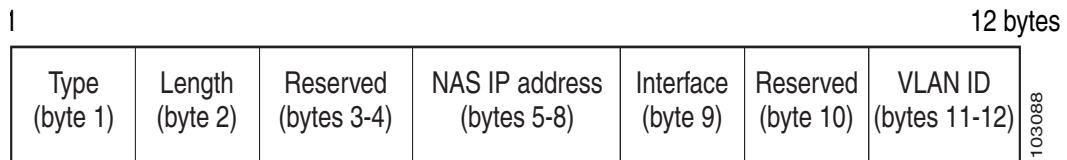

Note

This feature option is applicable to LAN and VLAN interfaces only.

In some cases, the host IP address is assigned statically. The IP Unnumbered Interfaces feature can learn the static host IP address dynamically.

IP Unnumbered Configuration Guidelines and Restrictions

When using (or configuring) IP Unnumbered Interface, consider these guidelines and restrictions:

- For IP Unnumbered Interfaces, the following features are not supported:
 - Dynamic routing protocols
 - HSRP/VRRP
 - Static ARP
 - Unnumbered Interface and Numbered Interface in different VRFs

- The option to add *dhcp host routes* as connected routes is available in Cisco IOS. When using connected mode, however, the **clear ip route *** command deletes the dhcp host connected routes permanently.

Workarounds:

- For a layer 3 interface (SVI), enter **shut** then **no shut**.
- To enable IP unnumbered to use static routes, enter the **ip dhcp route static** command.
- IP Redirect is not sent by an interface configured with IP Unnumbered Interface.
- IP Unnumbered Interface is unable to forward multicast source packets.

Configuring IP Unnumbered Interface Support with DHCP Server



Note

DHCP must be configured and operational before you perform this task.

This section contains the following procedures:

- [Configuring IP Unnumbered Interface Support on LAN and VLAN Interfaces, page 17-4](#)
- [Configuring IP Unnumbered Interface Support on a Range of Ethernet VLANs, page 17-5](#)

Configuring IP Unnumbered Interface Support on LAN and VLAN Interfaces

To configure IP unnumbered interface support on a single LAN or VLAN interface, perform this task.

	Command	Purpose
Step 1	Switch# enable	Enables privileged EXEC mode. Enter your password if prompted.
Step 2	Switch# configure terminal	Enters global configuration mode.
Step 3	Switch(config)# interface [fastethernet gigabitethernet tengigabitethernet vlan <i>vlan</i> port-channel loopback]	Enters interface configuration mode and the interface to be configured as a tunnel port.
Step 4	Switch(config-if)# ip unnumbered <i>type number</i>	Enables IP processing on an interface without assigning an explicit IP address to the interface. The <i>type</i> and <i>number</i> arguments specify another interface on which the switch has an assigned IP address. The interface specified cannot be another unnumbered interface.
Step 5	Switch(config-if)# exit	Returns to global configuration mode.
Step 6	Switch(config)# end	Returns to privileged EXEC mode.
Step 7	Switch# show running-config	Verifies that IP unnumbered support has been configured correctly.

In the following example, Ethernet VLAN 10 is configured as an IP unnumbered interfaces:

```
Switch> enable
Switch# configure terminal
Enter configuration commands, one per line. End with CNTL/Z.
Switch(config)# interface vlan 10
Switch(config-if)# ip unnumbered Lookback 0
```

Configuring IP Unnumbered Interface Support on a Range of Ethernet VLANs

To configure IP unnumbered interface support on a range of Ethernet VLAN interfaces, perform this task:

	Command or Action	Purpose
Step 1	Switch# enable	Enables privileged EXEC mode. Enter your password if prompted.
Step 2	Switch# configure terminal	Enters global configuration mode.
Step 3	Switch(config)# interface range {{ fastethernet gigabitethernet vlan vlan } <i>slot/interface</i> { fastethernet gigabitethernet vlan vlan } <i>slot/interface</i> macro macro-name }	Executes commands on multiple interfaces at the same time. A hyphen must be entered with a space on either side to separate the range information.
Step 4	Switch(config-if)# ip unnumbered type number	Enables IP processing on an interface without assigning an explicit IP address to the interface. The <i>type</i> and <i>number</i> arguments specify another interface on which the switch has an assigned IP address. The specified interface cannot be another unnumbered interface.
Step 5	Switch(config-if)# exit	Returns to global configuration mode.
Step 6	Switch(config)# end	Returns to privileged EXEC mode.
Step 7	Switch# show running-config	Verifies that IP unnumbered support has been configured correctly.

In the following example, VLANs in the range from 1 to 10 are configured as IP unnumbered interfaces, sharing IP address of Fast Ethernet 3/1:

```
Switch> enable
Switch# configure terminal
Enter configuration commands, one per line. End with CNTL/Z.
Switch(config)# interface range vlan 1 - 10
Switch(config-if)# ip unnumbered fastethernet 3/1
Switch(config-if)# exit
Switch(config)# end
```

Configuring IP Unnumbered Interface Support with Connected Host Polling

To configure IP unnumbered interface support with connected host polling, perform this task:

	Command	Purpose
Step 1	Switch# enable	Enables privileged EXEC mode. Enter your password if prompted.
Step 2	Switch# configure terminal	Enters global configuration mode.
Step 3	Switch(config)# interface vlan <i>vlan-id</i>	Enters interface configuration mode and the interface to be configured as a tunnel port.
Step 4	Switch(config-if)# ip unnumbered <i>type</i> <i>number</i> poll	Enables IP processing and connected host polling on an interface without assigning an explicit IP address to the interface <i>type</i> and <i>number</i> specify another interface on which the switch has an assigned IP address. The interface specified cannot be another unnumbered interface. The <i>type</i> argument can have the values: <i>loopback</i> , <i>fastethernet</i> , <i>gigabitethernet</i> , <i>svi</i> , and <i>portchannel</i> .
Step 5	Switch(config-if)# exit	Returns to global configuration mode.
Step 6	Switch(config)# ip arp poll queue <10-10000>	Configures the global backlog queue of host addresses to be discovered. Default for the queue size is 1000.
Step 7	Switch(config)# ip arp poll rate <10-10000>	Configures the maximum number of ARP requests sent over unnumbered interfaces. Default number of ARP requests is 1000 packet per second.
Step 8	Switch(config)# end	Returns to privileged EXEC mode.
Step 9	Switch# show running-config	Verifies that IP unnumbered support has been configured correctly.

The following example shows how to enable IP processing and connected host polling on Fast Ethernet interface 6/2. It also shows how to set the global backlog queue to 2000 and the maximum number of ARP requests to 500:

```
Switch# configure terminal
Enter configuration commands, one per line. End with CNTL/Z.
Switch(config)# interface fastEthernet 6/2
Switch(config-if)# no switchport
Switch(config-if)# ip unnumbered loopback 0 poll
Warning: dynamic routing protocols will not work on non-point-to-point interfaces with IP
unnumbered configured.
Switch(config-if)# exit
Switch(config)# ip arp poll queue 2000
Switch(config)# ip arp poll rate 500
Switch(config)# end
```

Displaying IP Unnumbered Interface Settings

Use the **show ip interface unnumbered** command to display status of an unnumbered interface with connected host polling for the switch.

To display **status of an unnumbered interface**, enter this command:

Command	Purpose
Switch# show ip interface [type number] unnumbered [detail]	Displays the status of unnumbered interface with connected host polling for the Catalyst 4500 series switch.

The following example shows how to display the status of unnumbered interfaces with connected host polling:

```
Switch# show ip interface loopback 0 unnumbered detail
Number of unnumbered interfaces with polling: 1
Number of IP addresses processed for polling: 2
10.1.1.7
10.1.1.8
Number of IP addresses in queue for polling: 2 (high water mark: 3)
10.1.1.17
10.1.1.18
```

To display key statistic for the backlog of unnumbered interfaces with connected host polling for the switch, perform this task:

Command	Purpose
Switch# show ip arp poll [detail]	Displays key statistic for the backlog of unnumbered interfaces with connected host polling for the switch.

The following example shows how to display key statistic for the backlog of unnumbered interfaces with connected host polling:

```
Switch# show ip arp poll
Number of IP addresses processed for polling: 439
Number of IP addresses in queue for polling: 3 (high water mark: 0, max: 1000)
Number of requests dropped:
  Queue was full: 0
  Request was throttled by incomplete ARP: 0
  Duplicate request was found in queue: 0
```

To clear the key statistic for the backlog of unnumbered interfaces, use the **clear ip arp poll statistic** command, as follows:

```
Switch# clear ip arp poll statistic
Switch# show ip arp poll
Number of IP addresses processed for polling: 0
Number of IP addresses in queue for polling: 0 (high water mark: 0, max: 1000)
Number of requests dropped:
  Queue was full: 0
  Request was throttled by incomplete ARP: 0
  Duplicate request was found in queue: 0
```

Troubleshooting IP Unnumbered Interface

To understand how to debug connect host polling, see the Cisco IOS documentation of the **debug arp** command on cisco.com.

When an IP unnumbered interface shares the IP address of a loopback interface whose prefix is advertised in an OSPF network, you must modify the loopback interface as a point-to-point interface. Otherwise, only the loopback interface host route is advertised to an OSPF neighbor.

```
Switch(config)# int loopback 0
Switch(config-if)# ip address
Switch(config-if)# ip address 10.1.0.1 255.255.0.0
Switch(config-if)# ip ospf network point-to-point
Switch(config-if)# end
```

Related Documents

Related Topic	Document Title
DHCP and other IP addressing configuration tasks	“IP Addressing and Services” section of the <i>Cisco IOS IP Addressing Services Configuration Guide, Release 12.4</i>
DHCP and other IP addressing commands	<i>Cisco IOS IP Addressing Services Command Reference, Release 12.4 T</i>
VLAN configuration tasks	“Virtual LANs” chapter of the <i>Cisco IOS LAN Switching Configuration Guide, Release 12.4</i>
VLAN configuration commands	<i>Cisco IOS LAN Switching Command Reference, Release 12.4 T</i>