



Mount the Chassis

- [Unpack and Inspect the Chassis, on page 1](#)
- [Rack-Mount the Chassis Using Slide Rails, on page 2](#)
- [Ground the Chassis, on page 8](#)

Unpack and Inspect the Chassis



Note The chassis is thoroughly inspected before shipment. If any damage occurred during transportation or any items are missing, contact your customer service representative immediately. Keep the shipping container in case you need to send the chassis back due to damage.

See [Package Contents](#) for a list of what shipped with the chassis.

Procedure

- Step 1** Remove the chassis from its cardboard container and save all packaging material.
- Step 2** Compare the shipment to the equipment list provided by your customer service representative. Verify that you have all items.
- Step 3** Check for damage and report any discrepancies or damage to your customer service representative. Have the following information ready:
- Invoice number of shipper (see the packing slip)
 - Model and serial number of the damaged unit
 - Description of damage
 - Effect of damage on the installation
-

Rack-Mount the Chassis Using Slide Rails

This procedure describes how to install the Secure Firewall 4200 in a rack using slide rails. It applies to all models of the 4200 series. You use the pegs on the chassis to secure the slide rail. See [Product ID Numbers](#) for a list of the PIDs associated with racking the chassis. You can install the optional cable management bracket on all models of the Secure Firewall 4200.

The rack is a standard Electronic Industries Association (EIA) rack. It is a 4-post-EIA-310-D, which is the current revision as specified by EIA. The vertical hole spacing alternates at .50 inches (12.70 mm) to .625 inches (15.90 mm) to .625 inches (15.90 mm) and repeats. The start and stop space is in the middle of the .50-inch holes. The horizontal spacing is 18.312 inches (465.1 mm), and the rack opening is specified as a minimum of 17.75 inches (450 mm).

You need the following to install the Secure Firewall 4200 in a rack using slide rails:

- Phillips screwdriver
- Two slide rails (part number 800-109129-01)
- Slide rail accessories kit (part number 53-101561-01):
 - Two slide rail mounting brackets (part number 700-121935-01)
 - Six 8-32 x 0.302-inch slide rail mounting bracket Phillips screws (part number 48-102184-01) for securing the brackets to the chassis
 - Two M3 x 0.5 x 6-mm Phillips screws (part number 48-101144-01) for securing the chassis to your rack
- Cable management bracket kit (optional) (part number 69-101031-01)
 - Two cable management brackets (part number 700-130991-01)
 - Four 8-32 x 0.375-inch Phillips screws (part number 48-2696-01)

Slide rail assemblies work with four-post racks and cabinets with square slots, round 7.1mm holes, #10-32 threaded holes, and #12-24 threaded holes on the rack post front. The slide rail works with front to back spacing of rack posts from 24 to 36 inches. The rack-mounting posts need to be 2 to 3.5 mm thick to work with the slide rail rack mounting.

Safety Warnings

Take note of the following warnings:



Warning Statement 164—Lifting Requirement

Two people are required to lift the heavy parts of the product. To prevent injury, keep your back straight and lift with your legs, not your back.



Warning Statement 1006—Chassis Warning for Rack-Mounting and Servicing

To prevent bodily injury when mounting or servicing this unit in a rack, you must take special precautions to ensure that the system remains stable. The following guidelines are provided to ensure your safety:

- This unit should be mounted at the bottom of the rack if it is the only unit in the rack.
 - When mounting this unit in a partially filled rack, load the rack from the bottom to the top with the heaviest component at the bottom of the rack.
 - If the rack is provided with stabilizing devices, install the stabilizers before mounting or servicing the unit in the rack.
-



Warning Statement 1024—Ground Conductor

This equipment must be grounded. To reduce the risk of electric shock, never defeat the ground conductor or operate the equipment in the absence of a suitably installed ground conductor. Contact the appropriate electrical inspection authority or an electrician if you are uncertain that suitable grounding is available.



Warning Statement 1047—Overheating Prevention

To reduce the risk of fire or bodily injury, do not operate the unit in an area that exceeds the maximum recommended ambient temperature of 104°F (40°C).



Warning Statement 1073—No User-Serviceable Parts

There are no serviceable parts inside. To avoid risk of electric shock, do not open.

Procedure

-
- Step 1** Attach the slide-rail locking brackets to each side of the chassis using the six 8-32 x 0.302-inch Phillips screws (three per side).

Figure 1: Attach the Slide-Rail Locking Bracket to the Side of the Chassis

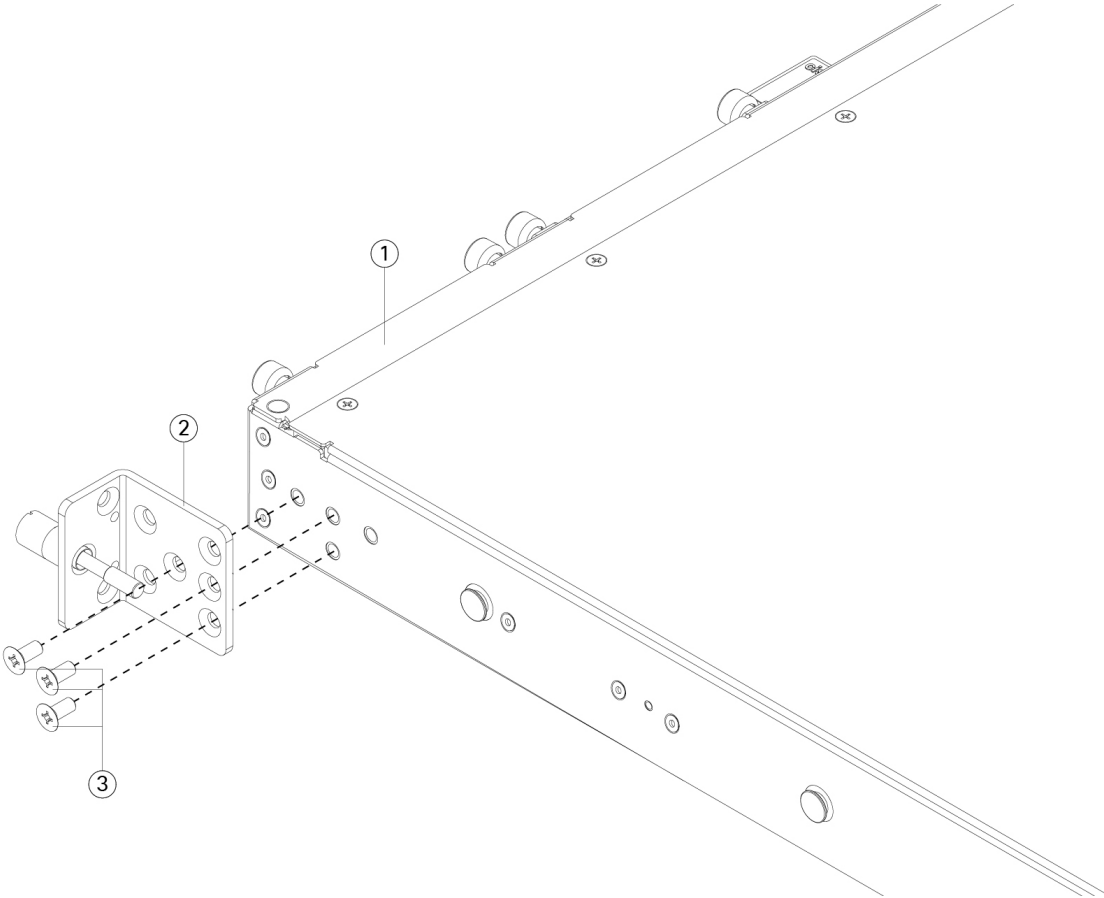

1	Chassis	2	Slide-rail locking bracket
3	8-32 x 0.302-inch Phillips screws (three per side)		

Step 2 (Optional) Attach the cable management bracket to the slide-rail locking bracket:
a) Install the cable management screws into the slide-rail locking bracket.

Figure 2: Install the Cable Management Screws into the Slide-Rail Locking Bracket

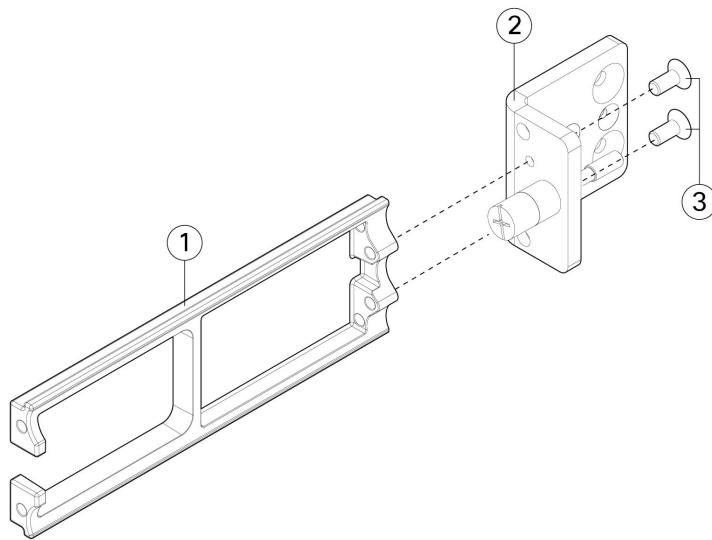

1	Cable management bracket	2	Rack-mount bracket
3	8-32 x 0.375-inch Phillips screws (two per bracket)		—

- b) Install two 8-32 x 0.375 inch Phillips screws through the inside of the slide-rail locking bracket to secure the cable management bracket to slide-rail locking bracket.

Step 3

Attach the inner rails to the sides of the chassis:

- a) Remove the inner rails from the slide rail assemblies.
- b) Align an inner rail with each side of the chassis:
 - Align the inner rail so that the three slots on the rail line up with the three pegs on the side of the chassis.

Figure 3: Line up the Inner Rail with the Pegs on the Chassis

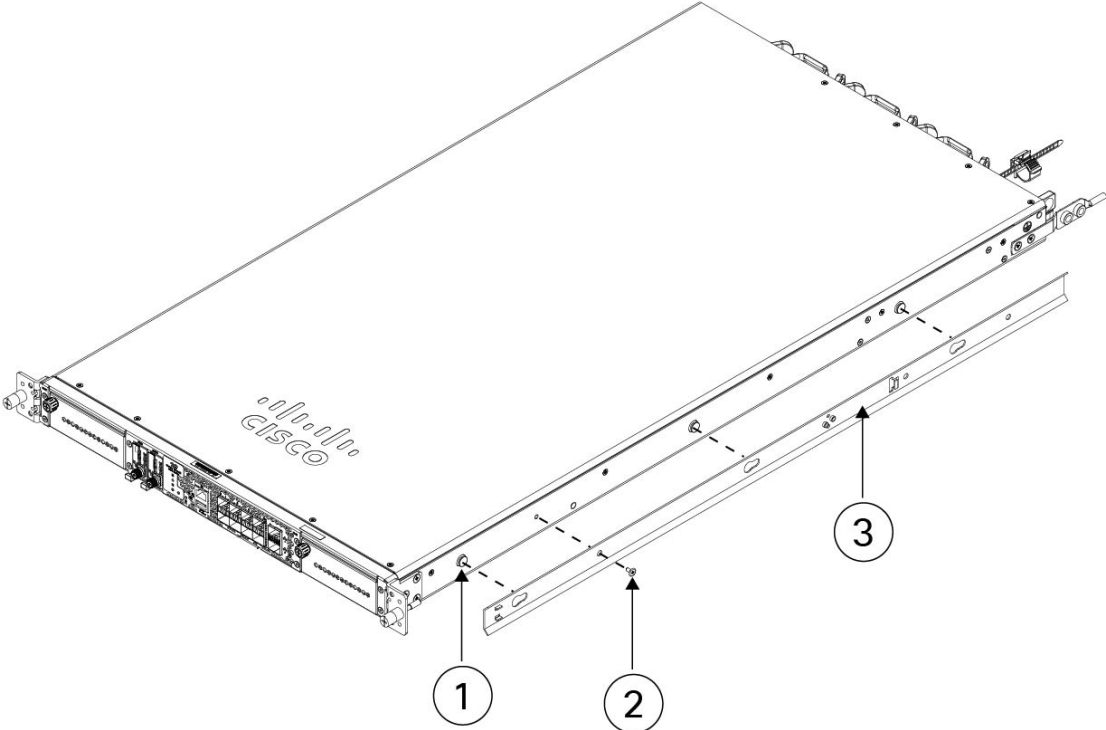

1	Mounting peg on the chassis for the keyed slot	2	M3 x 0.5 x 6-mm Phillips screws (one per side)
3	Inner rail		

- c) Set the keyed slots over the screws/pegs, and then slide the rail toward the front to lock it in place on the screw/pegs. The rear key slot has a metal clip that locks over the screw/peg.
- d) Using one M3 x 0.5 x 6-mm Phillips screw, secure the inner rail to the side of the chassis to prevent sliding.
- e) Install the second inner rail to the opposite side of the chassis and secure with the other M3 x 0.5 x 6-mm screw.

Step 4 Open the front securing plate on both slide-rail assemblies. The front end of the slide-rail assembly has a spring-loaded securing plate that must be open before you can insert the mounting pegs into the rack-post holes.

On the outside of the assembly, push the green arrow button toward the rear to open the securing plate.

Figure 4: Front Securing Mechanism Inside the Front End

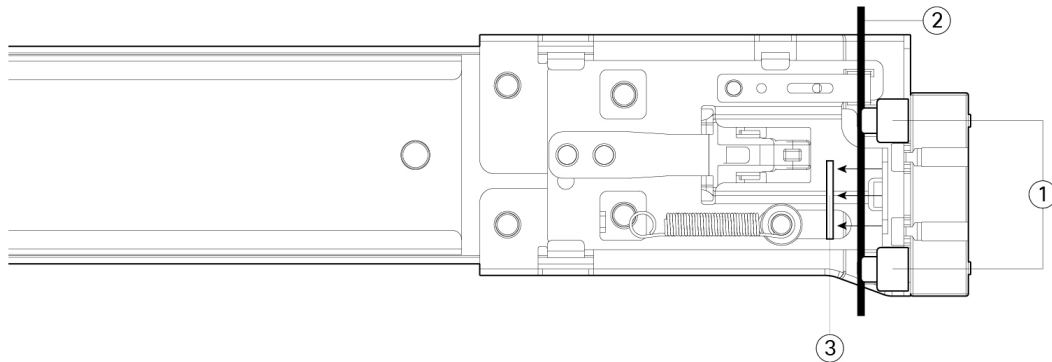

1	Front mounting pegs Note Works with square slots, 7.1 mm holes, and 10-32 threaded holes	2	Securing plate shown pulled back to open position
3	Rack post	—	

Step 5 Install the slide rails into the rack:

- a) Align one slide-rail assembly front end with the front rack-post holes that you want to use.

The slide rail front-end wraps around the outside of the rack post and the mounting pegs enter the rack-post holes from the outside-front.

Note

The rack post must be between the mounting pegs and the open securing plate.

- b) Push the mounting pegs into the rack-post holes from the outside-front.
- c) Press the securing plate release button marked 'PUSH.' The spring-loaded securing plate closes to lock the pegs in place.
- d) Adjust the slide-rail length, and then push the rear mounting pegs into the corresponding rear rack-post holes. The slide rail must be level front-to-rear.
- The rear mounting pegs enter the rear rack-post holes from the inside of the rack post.
- e) Attach the second slide-rail assembly to the opposite side of the rack. Make sure that the two slide-rail assemblies are at the same height with each other and are level front-to-back.
- f) Pull the inner slide rails on each assembly out toward the rack front until they hit the internal stops and lock in place.

Step 6 Insert the chassis into the slide rails.

- a) Align the rear of the inner rails that are attached to the chassis sides with the front ends of the empty slide rails on the rack.
- b) Push the inner rails into the slide rails on the rack until they stop at the internal stops.
- c) Slide the release clip toward the rear on both inner rails, and then continue pushing the chassis into the rack until the mounting brackets meet the front of the slide rail.

Figure 5: Inner Rail Release Clip

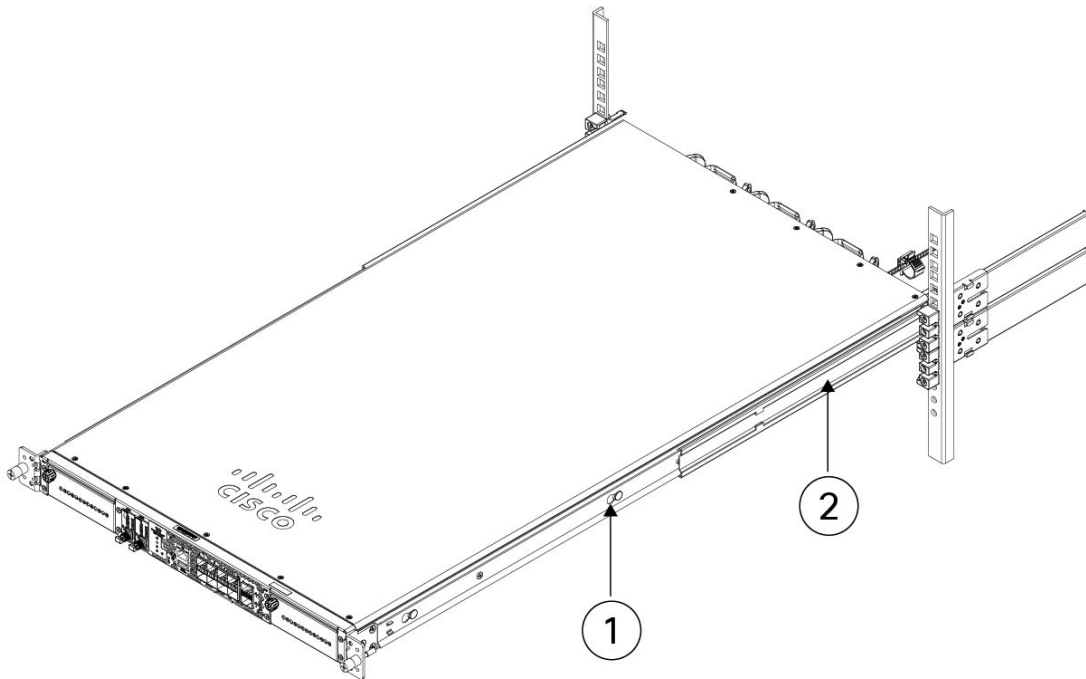

1 Inner rail release clip	2 Inner rail attached to chassis
---------------------------	----------------------------------

Step 7 Use the captive screws on the front of the mounting brackets to fully secure the chassis to the rack.

What to do next

- See [Ground the Chassis, on page 8](#) for the procedure to ground the Secure Firewall 4200.

Ground the Chassis



Note Grounding the chassis is required, even if the rack is already grounded. A grounding kit is provided for attaching a grounding lug. The grounding lug must be Nationally Recognized Testing Laboratory (NRTL)-listed. In addition, a copper conductor (wires) must be used and the copper conductor must comply with National Electrical Code (NEC) code for ampacity.

You need the following items that you provide:

- Wire-stripping tool
- Crimping tool
- Grounding cable

- You need the following items from the accessory kit:
 - One grounding lug (part number 32-100152-01)
 - One grounding lug bracket (part number 700-122528-01)
 - Two M4.0 x 0.6 mm flat-head Phillips screws (part number 48-2030-01)
 - Two ¼-20 x 0.297-inch button-head screws (part number 48-102252-01)
 - Two 0.469-inch OD, 0.261-inch ID, 0.025-inch T washers (part number 49-100464-01)

Safety Warnings

Take note of the following warnings:



Warning Statement 1024—Ground Conductor

This equipment must be grounded. To reduce the risk of electric shock, never defeat the ground conductor or operate the equipment in the absence of a suitably installed ground conductor. Contact the appropriate electrical inspection authority or an electrician if you are uncertain that suitable grounding is available.



Warning Statement 1046—Installing or Replacing the Unit

To reduce risk of electric shock, when installing or replacing the unit, the ground connection must always be made first and disconnected last.

If your unit has modules, secure them with the provided screws.

Procedure

Step 1 Use a wire-stripping tool to remove approximately 0.75 inches (19 mm) of the covering from the end of the grounding cable.

Step 2 Insert the stripped end of the grounding cable into the open end of the grounding lug.

Figure 6: Insert the Cable into the Grounding Lug

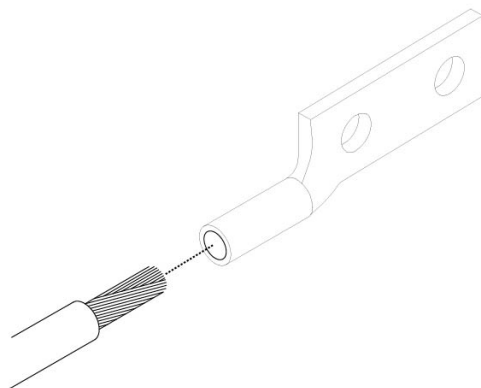

- Step 3** Use the crimping tool to secure the grounding cable in the grounding lug.
- Step 4** Remove the adhesive label from the grounding pad on the chassis.
- Step 5** Insert the grounding lug into the grounding lug bracket using the 2 button-head screws and washers.
- Step 6** Attach the grounding lug bracket against the grounding pad on the left side of the chassis so that there is solid metal-to-metal contact, and insert the two M4.0 x 0.6 mm flat-head Phillips screws through the holes in the grounding lug bracket and into the grounding pad.

Figure 7: Attach the Grounding Lug

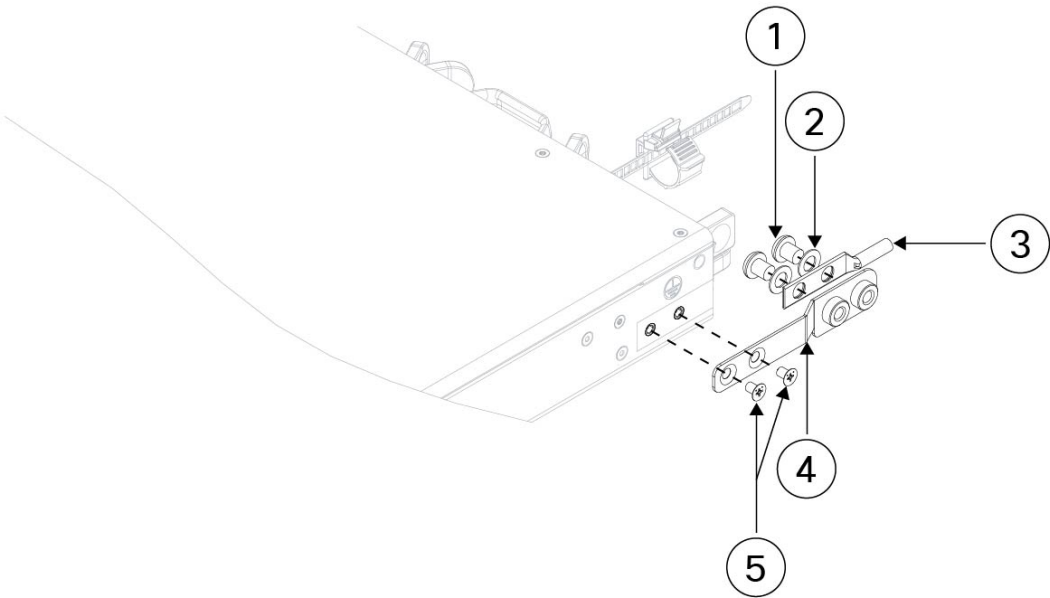

1	Two ¼-20 x .297 inch button-head screws	2	Two lock-internal washers
3	Grounding lug	4	Grounding lug bracket
5	Two M4.0 x .06 mm flat-head screws		—

- Step 7** Make sure that the lug and cable do not interfere with other equipment.
- Step 8** Prepare the other end of the grounding cable and connect it to an appropriate grounding point in your site to ensure adequate earth ground.

What to do next

Install the cables according to your default software configuration as described in the [Cisco Secure 4200 Getting Started Guide](#).