



## **FireSIGHT eStreamer Integration Guide**

Version 5.3.1  
June 23, 2014

THE SPECIFICATIONS AND INFORMATION REGARDING THE PRODUCTS IN THIS MANUAL ARE SUBJECT TO CHANGE WITHOUT NOTICE. ALL STATEMENTS, INFORMATION, AND RECOMMENDATIONS IN THIS MANUAL ARE BELIEVED TO BE ACCURATE BUT ARE PRESENTED WITHOUT WARRANTY OF ANY KIND, EXPRESS OR IMPLIED. USERS MUST TAKE FULL RESPONSIBILITY FOR THEIR APPLICATION OF ANY PRODUCTS.

**Cisco Systems, Inc.**  
[www.cisco.com](http://www.cisco.com)  
Cisco has more than 200 offices worldwide.  
Addresses, phone numbers, and fax numbers  
are listed on the Cisco website at  
[www.cisco.com/go/offices](http://www.cisco.com/go/offices).

THE SOFTWARE LICENSE AND LIMITED WARRANTY FOR THE ACCOMPANYING PRODUCT ARE SET FORTH IN THE INFORMATION PACKET THAT SHIPPED WITH THE PRODUCT AND ARE INCORPORATED HEREIN BY THIS REFERENCE. IF YOU ARE UNABLE TO LOCATE THE SOFTWARE LICENSE OR LIMITED WARRANTY, CONTACT YOUR CISCO REPRESENTATIVE FOR A COPY.

The Cisco implementation of TCP header compression is an adaptation of a program developed by the University of California, Berkeley (UCB) as part of UCB's public domain version of the UNIX operating system. All rights reserved. Copyright © 1981, Regents of the University of California.

NOTWITHSTANDING ANY OTHER WARRANTY HEREIN, ALL DOCUMENT FILES AND SOFTWARE OF THESE SUPPLIERS ARE PROVIDED "AS IS" WITH ALL FAULTS. CISCO AND THE ABOVE-NAMED SUPPLIERS DISCLAIM ALL WARRANTIES, EXPRESSED OR IMPLIED, INCLUDING, WITHOUT LIMITATION, THOSE OF MERCHANTABILITY, FITNESS FOR A PARTICULAR PURPOSE AND NONINFRINGEMENT OR ARISING FROM A COURSE OF DEALING, USAGE, OR TRADE PRACTICE.

IN NO EVENT SHALL CISCO OR ITS SUPPLIERS BE LIABLE FOR ANY INDIRECT, SPECIAL, CONSEQUENTIAL, OR INCIDENTAL DAMAGES, INCLUDING, WITHOUT LIMITATION, LOST PROFITS OR LOSS OR DAMAGE TO DATA ARISING OUT OF THE USE OR INABILITY TO USE THIS MANUAL, EVEN IF CISCO OR ITS SUPPLIERS HAVE BEEN ADVISED OF THE POSSIBILITY OF SUCH DAMAGES.

Cisco and the Cisco logo are trademarks or registered trademarks of Cisco and/or its affiliates in the U.S. and other countries. To view a list of Cisco trademarks, go to this URL: [www.cisco.com/go/trademarks](http://www.cisco.com/go/trademarks). Third-party trademarks mentioned are the property of their respective owners. The use of the word partner does not imply a partnership relationship between Cisco and any other company. (1110R)

Any Internet Protocol (IP) addresses and phone numbers used in this document are not intended to be actual addresses and phone numbers. Any examples, command display output, network topology diagrams, and other figures included in the document are shown for illustrative purposes only. Any use of actual IP addresses or phone numbers in illustrative content is unintentional and coincidental.

© 2014 Cisco Systems, Inc. All rights reserved.



---

CHAPTER 1

**Introduction 1-1**

- Major Changes in eStreamer Version 5.3.1 1-1
- Using this Guide 1-2
- Prerequisites 1-3
- Product Versions for FireSIGHT System Releases 1-3
- Document Conventions 1-4

---

CHAPTER 2

**Understanding the eStreamer Application Protocol 2-1**

- Connection Specifications 2-1
- Understanding eStreamer Communication Stages 2-2
  - Establishing an Authenticated Connection 2-2
  - Requesting Data from eStreamer 2-3
  - Accepting Data from eStreamer 2-5
  - Terminating Connections 2-5
- Understanding eStreamer Message Types 2-6
  - eStreamer Message Header 2-7
- Null Message Format 2-7
- Error Message Format 2-8
- Event Stream Request Message Format 2-10
  - Initial Timestamp 2-11
  - Request Flags 2-11
- Event Data Message Format 2-17
  - Understanding the Organization of Event Data Messages 2-17
  - Intrusion Event and Metadata Message Format 2-18
  - Discovery Event Message Format 2-19
  - Connection Event Message Format 2-20
  - Correlation Event Message Format 2-20
  - Event Extra Data Message Format 2-22
  - Data Block Header 2-24
- Host Request Message Format 2-24
- Host Data and Multiple Host Data Message Format 2-27
- Streaming Information Message Format 2-29

Streaming Request Message Format 2-30

Streaming Service Request Structure 2-30

Streaming Event Type Structure 2-32

Sample Extended Request Messages 2-34

    Streaming Information Message 2-34

    Streaming Request Message 2-35

Message Bundle Format 2-35

Understanding Metadata 2-36

    Metadata Transmission 2-36

CHAPTER 3

**Understanding Intrusion and Correlation Data Structures 3-1**

Intrusion Event and Metadata Record Types 3-1

    Packet Record 4.8.0.2+ 3-4

    Priority Record 3-5

    Intrusion Event Record 5.3.1+ 3-6

    Intrusion Impact Alert Data 5.3+ 3-12

    User Record 3-15

    Rule Message Record for 4.6.1+ 3-16

    Classification Record for 4.6.1+ 3-17

    Correlation Policy Record 3-18

    Correlation Rule Record 3-20

    Intrusion Event Extra Data Record 3-21

    Intrusion Event Extra Data Metadata 3-23

    Security Zone Name Record 3-25

    Interface Name Record 3-26

    Access Control Policy Name Record 3-27

    Access Control Rule ID Record Metadata 3-28

    Managed Device Record Metadata 3-30

    Malware Event Record 5.1.1+ 3-30

    Collective Security Intelligence Cloud Name Metadata 3-31

    Malware Event Type Metadata 3-33

    Malware Event Subtype Metadata 3-34

    FireAMP Detector Type Metadata 3-34

    FireAMP File Type Metadata 3-35

    Correlation Event for 5.1+ 3-36

Understanding Series 2 Data Blocks 3-44

    Series 2 Primitive Data Blocks 3-47

    String Data Block 3-48

    BLOB Data Block 3-48

|  |      |
|--|------|
| List Data Block                              | 3-49 |
| Generic List Data Block                      | 3-50 |
| UUID String Mapping Data Block               | 3-51 |
| Access Control Policy Rule ID Metadata Block | 3-52 |
| ICMP Type Data Block                         | 3-53 |
| ICMP Code Data Block                         | 3-54 |
| Access Control Policy Rule Reason Data Block | 3-55 |
| IP Reputation Category Data Block            | 3-56 |
| File Event for 5.3.1+                        | 3-57 |
| Malware Event Data Block 5.3.1+              | 3-64 |
| File Event SHA Hash for 5.3+                 | 3-71 |
| Rule Documentation Data Block for 5.2+       | 3-72 |
| Geolocation Data Block for 5.2+              | 3-76 |
|  | 3-77 |

## CHAPTER 4

## Understanding Discovery & Connection Data Structures

|  |      |
|--|------|
|  | 4-1  |
| Discovery and Connection Event Data Messages           | 4-2  |
| Discovery and Connection Event Record Types            | 4-2  |
| Metadata for Discovery Events                          | 4-6  |
| Discovery Event Header 5.2+                            | 4-32 |
| Discovery and Connection Event Types and Subtypes      | 4-34 |
| Host Discovery Structures by Event Type                | 4-36 |
| Identity Conflict and Identity Timeout System Messages | 4-53 |
| User Data Structures by Event Type                     | 4-54 |
| Understanding Discovery (Series 1) Blocks              | 4-55 |
| Series 1 Data Block Header                             | 4-55 |
| Series 1 Primitive Data Blocks                         | 4-56 |
| Host Discovery and Connection Data Blocks              | 4-56 |
| String Data Block                                      | 4-63 |
| BLOB Data Block  | 4-64 |
| List Data Block  | 4-65 |
| Generic List Block                                     | 4-66 |
| Sub-Server Data Block                                  | 4-66 |
| Protocol Data Block                                    | 4-68 |
| Integer (INT32) Data Block                             | 4-69 |
| Vulnerability Reference Data Block                     | 4-69 |
| VLAN Data Block  | 4-71 |
| Server Banner Data Block                               | 4-72 |

|   |       |
|---|-------|
| String Information Data Block                         | 4-73  |
| Attribute Address Data Block 5.2+                     | 4-73  |
| Attribute List Item Data Block                        | 4-74  |
| Attribute Value Data Block                            | 4-75  |
| Full Sub-Server Data Block                            | 4-77  |
| Operating System Data Block 3.5+                      | 4-79  |
| Policy Engine Control Message Data Block              | 4-79  |
| Attribute Definition Data Block for 4.7+              | 4-80  |
| User Protocol Data Block                              | 4-83  |
| User Client Application Data Block for 5.1.1+         | 4-85  |
| User Client Application List Data Block               | 4-86  |
| IP Address Range Data Block for 5.2+                  | 4-88  |
| Attribute Specification Data Block                    | 4-89  |
| Host IP Address Data Block                            | 4-90  |
| MAC Address Specification Data Block                  | 4-91  |
| Address Specification Data Block                      | 4-92  |
| Connection Chunk Data Block for 5.1.1+                | 4-93  |
| Fix List Data Block                                   | 4-95  |
| User Server Data Block                                | 4-95  |
| User Server List Data Block                           | 4-97  |
| User Hosts Data Block 4.7+                            | 4-98  |
| User Vulnerability Change Data Block 4.7+             | 4-99  |
| User Criticality Change Data Block 4.7+               | 4-101 |
| User Attribute Value Data Block 4.7+                  | 4-102 |
| User Protocol List Data Block 4.7+                    | 4-104 |
| Host Vulnerability Data Block 4.9.0+                  | 4-105 |
| Identity Data Block                                   | 4-106 |
| Host MAC Address 4.9+                                 | 4-108 |
| Secondary Host Update                                 | 4-109 |
| Web Application Data Block for 5.0+                   | 4-110 |
| Connection Statistics Data Block 5.3.1+               | 4-111 |
| Scan Result Data Block 5.2+                           | 4-118 |
| Host Server Data Block 4.10.0+                        | 4-120 |
| Full Host Server Data Block 4.10.0+                   | 4-122 |
| Server Information Data Block for 4.10.x, 5.0 - 5.0.2 | 4-126 |
| Full Server Information Data Block                    | 4-128 |
| Generic Scan Results Data Block for 4.10.0+           | 4-131 |
| Scan Vulnerability Data Block for 4.10.0+             | 4-133 |
| Full Host Client Application Data Block 5.0+          | 4-136 |
| Host Client Application Data Block for 5.0+           | 4-137 |

|  |              |
|--|--------------|
| User Vulnerability Data Block 5.0+                         | 4-139        |
| Operating System Fingerprint Data Block 5.1+               | 4-141        |
| Mobile Device Information Data Block for 5.1+              | 4-143        |
| Host Profile Data Block for 5.2+                           | 4-144        |
| User Product Data Block 5.1+                               | 4-152        |
| <b>User Data Blocks</b>                                    | <b>4-159</b> |
| User Account Update Message Data Block                     | 4-160        |
| User Information Data Block                                | 4-168        |
| User Login Information Data Block 5.1+                     | 4-171        |
| <b>Discovery and Connection Event Series 2 Data Blocks</b> | <b>4-173</b> |
| Access Control Rule Data Block                             | 4-173        |
| Access Control Rule Reason Data Block 5.1+                 | 4-174        |
| Security Intelligence Category Data Block 5.1+             | 4-175        |

**CHAPTER 5****Understanding Host Data Structures** 5-1

|                                   |     |
|-----------------------------------|-----|
| Full Host Profile Data Block 5.3+ | 5-1 |
|-----------------------------------|-----|

**CHAPTER 6****Configuring eStreamer** 6-1

|  |      |
|--|------|
| Configuring eStreamer on the eStreamer Server          | 6-1  |
| Configuring eStreamer Event Types                      | 6-2  |
| Adding Authentication for eStreamer Clients            | 6-3  |
| Using an Alternate Management Interface with eStreamer | 6-4  |
| Managing the eStreamer Service                         | 6-6  |
| Starting and Stopping the eStreamer Service            | 6-7  |
| eStreamer Service Options                              | 6-7  |
| Configuring the eStreamer Reference Client             | 6-8  |
| Setting Up the eStreamer Perl Reference Client         | 6-8  |
| Running the eStreamer Perl Reference Client            | 6-13 |

**APPENDIX A****Data Structure Examples** A-1

|  |      |
|--|------|
| Intrusion Event Data Structure Examples                    | A-1  |
| Example of an Intrusion Event for the Defense Center 5.3 + | A-1  |
| Example of an Intrusion Impact Alert                       | A-6  |
| Example of a Packet Record                                 | A-7  |
| Example of a Classification Record                         | A-8  |
| Example of a Priority Record                               | A-10 |
| Example of a Rule Message Record                           | A-11 |
| Example of a Version 5.1+ User Event                       | A-13 |

Discovery Data Structure Examples A-16  
     Example of a New Network Protocol Message A-16  
     Example of a New TCP Server Message A-18

APPENDIX B

**Understanding Legacy Data Structures B-1**

Legacy Intrusion Data Structures B-1  
     Intrusion Event (IPv4) Record 5.0.x - 5.1 B-2  
     Intrusion Event (IPv6) Record 5.0.x - 5.1 B-6  
     Intrusion Event Record 5.2.x B-11  
     Intrusion Event Record 5.3 B-17  
     Intrusion Event Record 5.1.1.x B-24  
     Intrusion Impact Alert Data B-29

Legacy Malware Event Data Structures B-32  
     Malware Event Data Block 5.1 B-32  
     Malware Event Data Block 5.1.1.x B-36  
     Malware Event Data Block 5.2.x B-42  
     Malware Event Data Block 5.3 B-48

Legacy Discovery Data Structures B-55  
     Legacy Discovery Event Header B-55  
     Legacy Server Data Blocks B-57  
     Attribute Address Data Block for 5.0 - 5.1.1.x B-57  
     Legacy Client Application Data Blocks B-58  
     Legacy Scan Result Data Blocks B-60  
     Legacy User Login Data Blocks B-68  
     Legacy Host Profile Data Blocks B-70  
     Legacy OS Fingerprint Data Blocks B-77

Legacy Connection Data Structures B-78  
     Connection Statistics Data Block 5.0 - 5.0.2 B-78  
     Connection Statistics Data Block 5.1 B-83  
     Connection Statistics Data Block 5.2.x B-89  
     Connection Chunk Data Block for 5.0 - 5.1 B-94  
     Connection Statistics Data Block 5.1.1.x B-96  
     Connection Statistics Data Block 5.3 B-102

Legacy File Event Data Structures B-108  
     File Event for 5.1.1.x B-109  
     File Event for 5.2.x B-112  
     File Event for 5.3 B-116  
     File Event SHA Hash for 5.1.1-5.2.x B-122

Legacy Correlation Event Data Structures B-123



|   |       |
|---|-------|
| Correlation Event for 5.0 - 5.0.2                   | B-123 |
| Legacy Host Data Structures                         | B-131 |
| Full Host Profile Data Block 5.0 - 5.0.2            | B-131 |
| Full Host Profile Data Block 5.1.1                  | B-140 |
| Full Host Profile Data Block 5.2.x                  | B-149 |
| Host Profile Data Block for 5.1.x                   | B-161 |
| IP Range Specification Data Block for 5.0 - 5.1.1.x | B-167 |





# Introduction

---

The Cisco Event Streamer (also known as eStreamer) allows you to stream FireSIGHT System intrusion, discovery, and connection data from the Cisco Defense Center or managed device (also referred to as the eStreamer server) to external client applications.

Note that eStreamer is not supported on virtual devices. To stream events from a virtual device, you can configure eStreamer on the Defense Center that the device reports to.

eStreamer uses a custom application layer protocol to communicate with connected client applications. As the purpose of eStreamer is simply to return data that the client requests, the majority of this guide describes the eStreamer formats for the requested data.

There are three major steps to creating and integrating an eStreamer client with a FireSIGHT System:

1. Write a client application that exchanges messages with the Defense Center or managed device using the eStreamer application protocol. The eStreamer SDK includes a reference client application.
2. Configure a Defense Center or device to send the required type of events to your client application.
3. Connect your client application to the Defense Center or device and begin exchanging data.

This guide provides the information you need to successfully create and run an eStreamer Version 5.3.1 client application.

## Major Changes in eStreamer Version 5.3.1

If you are upgrading your FireSIGHT System deployment to Version 5.3.1, please note the following changes, some of which may require you to update your eStreamer client:

- Fixed errors in the following blocks:
  - Fixed [Correlation Event for 5.1+](#), [page 3-36](#) with correct information for the handling of IPv4 addresses.
  - Fixed [Discovery Event Header 5.2+](#), [page 4-32](#) with correct information for the handling of IPv4 addresses.
  - Fixed [User Login Information Data Block 5.1+](#), [page 4-171](#) with correct information for the handling of IPv4 addresses.

- Replaced the following blocks:
  - Replaced [Intrusion Impact Alert Data, page B-29](#) with [Intrusion Impact Alert Data 5.3+, page 3-12](#), which has an IPv6 field.
  - Replaced [Malware Event Data Block 5.3, page B-48](#) with [Malware Event Data Block 5.3.1+, page 3-64](#), which has a security context field.
  - Replaced [File Event for 5.3, page B-116](#) with [File Event for 5.3.1+, page 3-57](#), which has a security context field.
  - Replaced [Intrusion Event Record 5.3, page B-17](#) with [Intrusion Event Record 5.3.1+, page 3-6](#), which has a security context field.
  - Replaced [Connection Statistics Data Block 5.3, page B-102](#) with [Connection Statistics Data Block 5.3.1+, page 4-111](#), which has a security context field.

## Using this Guide

At the highest level, the eStreamer service is a mechanism for streaming data from the FireSIGHT System to a requesting client. The service can stream the following categories of data:

- Intrusion event data and event extra data
- Correlation (compliance) event data
- Discovery event data
- User event data
- Metadata for events
- Host information
- Malware event data

Descriptions of the data structures returned by eStreamer make up the majority of this book. The chapters in the book are:

- [Understanding the eStreamer Application Protocol, page 2-1](#), which provides an overview of eStreamer communications, details some of the requirements for writing eStreamer client applications, and describes the four types of messages used to send commands to and receive data from the eStreamer service.
- [Understanding Intrusion and Correlation Data Structures, page 3-1](#), which documents the data formats used to return event data generated by the intrusion detection and correlation components and the data formats used to represent the intrusion and correlation events.
- [Understanding Discovery & Connection Data Structures, page 4-1](#), which documents the data formats used to return discovery, user, and connection event data.
- [Understanding Host Data Structures, page 5-1](#), which documents the data formats that eStreamer uses to return full host information data when it receives a host information request message.
- [Configuring eStreamer, page 6-1](#), which documents how to configure the eStreamer on a Defense Center or managed device. The chapter also documents the eStreamer command-line switches and provides instructions for manually starting and stopping the eStreamer service and for configuring the Defense Center or managed device to start eStreamer automatically.
- [Data Structure Examples, page A-1](#), which provides examples of eStreamer message packets in binary format.

- [Understanding Legacy Data Structures, page B-1](#), which documents the structure of legacy data structures that are no longer in use by the currently shipping product but may be used by older clients.

## Prerequisites

To understand the information in this guide, you should be familiar with the features and nomenclature of the FireSIGHT System and the function of its components in general, and with the different types of event data these components generate in particular. Definitions of unfamiliar or product-specific terms can frequently be obtained from the *FireSIGHT eStreamer Integration Guide*.

## Product Versions for FireSIGHT System Releases

Version numbers are used throughout this guide to describe the data format for events generated by the Defense Center and managed devices. The [FireSIGHT System Product Versions](#) table lists versions for each product by major release.

*Table 1-1 FireSIGHT System Product Versions*

| Release           | Defense Center Version | Master Defense Center Version | Intrusion Sensor Version | Sensor Version | Managed Device Version |
|-------------------|------------------------|-------------------------------|--------------------------|----------------|------------------------|
| IMS 3.0           | Management Console 3.0 | N/A                           | Network Sensor 3.0       | N/A            | N/A                    |
| IMS 3.1           | Management Console 3.1 | N/A                           | Network Sensor 3.1       | RNA Sensor 1.0 | N/A                    |
| IMS 3.2           | Management Console 3.2 | N/A                           | Network Sensor 3.2       | RNA Sensor 2.0 | N/A                    |
| 3D System 4.0     | Defense Center 4.0     | N/A                           | Intrusion Sensor 4.0     | RNA Sensor 3.0 | N/A                    |
| 3D System 4.5     | Defense Center 4.5     | N/A                           | Intrusion Sensor 4.5     | RNA Sensor 3.5 | N/A                    |
| 3D System 4.6.1   | Defense Center 4.6.1   | Master Defense Center 4.6.1   | N/A                      | N/A            | 4.6.1                  |
| 3D System 4.7     | Defense Center 4.7     | Master Defense Center 4.7     | N/A                      | N/A            | 4.7                    |
| 3D System 4.8     | Defense Center 4.8     | Master Defense Center 4.8     | N/A                      | N/A            | 4.8                    |
| 3D System 4.8.0.2 | Defense Center 4.8.0.2 | Master Defense Center 4.8.0.2 | N/A                      | N/A            | 4.8.0.2                |
| 3D System 4.9     | Defense Center 4.9     | Master Defense Center 4.9     | N/A                      | N/A            | 4.9                    |
| 3D System 4.9.1   | Defense Center 4.9.1   | Master Defense Center 4.9.1   | N/A                      | N/A            | 4.9.1                  |
| 3D System 4.10    | Defense Center 4.10    | Master Defense Center 4.10    | N/A                      | N/A            | 4.10                   |

Table 1-1 FireSIGHT System Product Versions (continued)

| Release          | Defense Center Version | Master Defense Center Version | Intrusion Sensor Version | Sensor Version | Managed Device Version |
|------------------|------------------------|-------------------------------|--------------------------|----------------|------------------------|
| 3D System 4.10.1 | Defense Center 4.10.1  | Master Defense Center 4.10.1  | N/A                      | N/A            | 4.10.1                 |
| 3D System 4.10.2 | Defense Center 4.10.2  | Master Defense Center 4.10.2  | N/A                      | N/A            | 4.10.2                 |
| 3D System 4.10.3 | Defense Center 4.10.3  | Master Defense Center 4.10.3  | N/A                      | N/A            | 4.10.3                 |
| 3D System 5.0    | Defense Center 5.0     | N/A                           | N/A                      | N/A            | 5.0                    |
| 3D System 5.1    | Defense Center 5.1     | N/A                           | N/A                      | N/A            | 5.1                    |
| 3D System 5.1.1  | Defense Center 5.1.1   | N/A                           | N/A                      | N/A            | 5.1.1                  |
| 3D System 5.2    | Defense Center 5.2     | N/A                           | N/A                      | N/A            | 5.2                    |
| 3D System 5.3    | Defense Center 5.3     | N/A                           | N/A                      | N/A            | 5.3                    |
| 3D System 5.3.1  | Defense Center 5.3.1   | N/A                           | N/A                      | N/A            | 5.3.1                  |

## Document Conventions

The [eStreamer Message Data Type Conventions](#) table lists the names used in this book to describe the various data field formats employed in eStreamer messages. Numeric constants used by the eStreamer service are typically unsigned integer values. Bit fields use low-order bits unless otherwise noted. For example, in a one-byte field containing five bits of flag data, the low-order five bits will contain the data.

Table 1-2 eStreamer Message Data Type Conventions

| Data Type    | Description   |
|--------------|---|
| nn-bit field | Bit field of nn bits  |
| byte         | 8-bit byte containing data of arbitrary format  |
| int8         | Signed 8-bit byte   |
| uint8        | Unsigned 8-bit byte   |
| int16        | Signed 16-bit integer   |
| uint16       | Unsigned 16-bit integer   |
| int32        | Signed 32-bit integer   |
| uint32       | Unsigned 32-bit integer   |
| uint64       | Unsigned 64-bit integer   |
| string       | Variable length field containing character data   |
| [n]          | Array subscript following any of the above data types to indicate n instances of the indicated data type, for example, uint8[4] |
| variable     | Collection of various data types  |
| BLOB         | Binary object of unspecified type, typically raw data as captured from a packet   |

## IP Addresses

The Cisco database stores IPv4 and IPv6 addresses in the same fields in a BINARY format. To get IPv6 addresses, convert to hex notation, for example: 20010db800000000000000000000004321. The database follows the RFC for storing IPv4 addresses by filling in bits 80-95 with 1's, which yields an invalid IPv6 address. For example, the IPv4 address 10.5.15.1 would be stored as

```
000000000000000000000000FFFF0A050F01.
```







# Understanding the eStreamer Application Protocol

---

The FireSIGHT System Event Streamer (eStreamer) uses a message-oriented protocol to stream events and host profile information to your client application. Your client can request event and host profile data from a Defense Center, and intrusion event data only from a managed device. Your client application initiates the data stream by submitting request messages, which specify the data to be sent, and then controls the message flow from the Defense Center or managed device after streaming begins.

Throughout this document, the eStreamer service on the Defense Center or a managed device may be referred to as the eStreamer server or eStreamer.

The following sections describe requirements for connecting to the eStreamer service and introduce commands and data formats used in the eStreamer protocol:

- [“Connection Specifications” section on page 2-1](#) describes the communication flow between the eStreamer service and your client and describes how the client interacts with it.
- [Understanding eStreamer Communication Stages, page 2-2](#) describes the communication protocol for client applications to submit data requests to the eStreamer server and for eStreamer to deliver the requested information to the client.
- [Understanding eStreamer Message Types, page 2-6](#) describes the message types used in the eStreamer protocol; discusses the basic structure of data packets used by eStreamer to return intrusion event data, discovery event data, metadata, and host data to a client; and provides other information to help you write a client that can interpret eStreamer messages.

## Connection Specifications

The eStreamer service:

- Communicates using TCP over an SSL connection (the client application must support SSL-based authentication).
- Accepts connection requests on port 8302.
- Waits for the client to initiate all communication sessions.
- Writes all message fields in network byte order (big endian).
- Encodes text in UTF-8.

# Understanding eStreamer Communication Stages

There are four major stages of communication that occur between a client and the eStreamer service:

1. The client establishes a connection with the eStreamer server and the connection is authenticated by both parties.  
See [“Establishing an Authenticated Connection” section on page 2-2](#) for more information.
2. The client requests data from the eStreamer service and specifies the types of data to be streamed. A single event request message can specify any combination of available event data, including event metadata. A single host profile request can specify a single host or multiple hosts.

Two request modes are available for requesting event data:

- Event Stream Request - the client submits a message containing request flags that specify the requested event types and version of each type, and the eStreamer server responds by streaming the requested data.
- Extended Request - the client submits a request with the same message format as for Event Stream requests but sets a flag for an extended request. This initiates a message interaction between client and eStreamer server through which the client requests additional information and version combinations not available via Event Stream requests.

For information on requesting data, see [“Requesting Data from eStreamer” section on page 2-3](#).

3. eStreamer establishes the requested data stream to the client.  
See [“Accepting Data from eStreamer” section on page 2-5](#) for more information.
4. The connection terminates.  
See [“Terminating Connections” section on page 2-5](#) for more information.

## Establishing an Authenticated Connection

Before a client can request data from eStreamer, the client must initiate an SSL-enabled TCP connection with the eStreamer service. When the client initiates the connection, the eStreamer server responds, initiating an SSL handshake with the client. As part of the SSL handshake, the eStreamer server requests the client’s authentication certificate, and verifies that the certificate is valid (signed by the Internal Certifying Authority [Internal CA] on the eStreamer server).



### Note

Cisco recommends that you also require your client to verify that the certificate presented by the eStreamer server has been signed by a trusted Certifying Authority. This is the Internal CA certificate included in the PKCS#12 file that Cisco provides when you register a new eStreamer client with the Defense Center or managed device. See [“Adding Authentication for eStreamer Clients” section on page 6-3](#) for more information.

After the SSL session is established, the eStreamer server performs an additional post-connection verification of the certificate. This includes verifying that the client connection originates from the host specified in the certificate and that the subject name of the certificate contains the appropriate value. If either post-connection check fails, the eStreamer server closes the connection. If necessary, you can configure the eStreamer service so that it does not perform a client host name check (see [“eStreamer Service Options” section on page 6-7](#) for more information).

While the client is not required to perform post-connection verification, Cisco recommends that the client perform this verification step. The authentication certificate contains the following field values in the subject name of the certificate:

*Table 2-1 Certificate Subject Name Fields*

| Field               | Value     |
|---------------------|-----------|
| title               | estreamer |
| generationQualifier | server    |

After the post-connection verification is finished, the eStreamer server awaits a data request from the client.

## Requesting Data from eStreamer

Your client performs the following high-level tasks in managing data requests:

- initializing the request session — see [Establishing a Session, page 2-3](#).
- requesting events from the eStreamer event archive — [Using Event Stream Requests and Extended Requests to Initiate Event Streaming, page 2-3](#).
- requesting host data — see [Requesting Host Data, page 2-4](#).
- changing a request — see [Changing a Request, page 2-4](#).

## Establishing a Session

The client establishes a session by sending an initial Event Stream request to the eStreamer service.

In this initial message, you can either include data request flags or submit the data requests in a follow-on message. This initial Event Stream request message itself is a prerequisite for all eStreamer requests, whether for event data or for host data. For information about using the Event Stream request message, see [Event Stream Request Message Format, page 2-10](#).

## Using Event Stream Requests and Extended Requests to Initiate Event Streaming

The eStreamer service provides two modes of requests for event streaming. Your request can combine modes. In both modes, your client starts the request with an Event Stream request message but sets the request flag bits differently. For details about the Event Stream message format, see [Event Stream Request Message Format, page 2-10](#).

When eStreamer receives an Event Stream request message, it processes the client request as follows:

- If the request message does **not** set bit 30 in the request flag field, eStreamer begins streaming any events requested by other set bits in the request flag field. For information, see [Submitting Event Stream Requests, page 2-4](#).
- If bit 30 **is** set in the Event Stream request, eStreamer provides extended request processing. Extended request flags must be sent if this bit is set. For information, see [Submitting Extended Requests, page 2-4](#). Note that eStreamer resolves any duplicate requests. If you request multiple versions of the same data, either by multiple flags or multiple extended requests, the highest version is used. For example, if eStreamer receives flag requests for discovery events version 1 and 6 and an extended request for version 3, it sends version 6.

## Submitting Event Stream Requests

Event stream requests use a simple process:

- Your client sends a request message to the eStreamer service with a start date and time and a request flag field that specifies the events and their version level to be included in the data stream.
- eStreamer streams events beginning at the specified time. For information about the streaming protocol, see [Accepting Data from eStreamer, page 2-5](#).

For information on the format and content of the client's Event Stream request message, see [Event Stream Request Message Format, page 2-10](#).

For information on the event types and versions of events that the client can request, see [Table 2-6 on page 2-12](#).

## Submitting Extended Requests

If you set bit 30 in the request flags field of an Event Stream Request message, you initiate an extended request, which starts a negotiation with the server. Extended request flags must be sent if this bit is set. For the event types available by extended request, see [Table 2-21 on page 2-34](#).

The steps for extended requests are as follows:

- Your client sends an Event Streaming Request message to eStreamer with the request flags bit 30 set to 1, which signals an extended request. See [Event Stream Request Message Format, page 2-10](#) for message format details.
- eStreamer answers with a Streaming Information message that advertises the list of services available to the client. For details about the Streaming Information message, see [Streaming Information Message Format, page 2-30](#).
- The client returns a Streaming Request message that indicates the service it wants to use, with a request list of event types and versions available from that service. The request list corresponds to setting bits in the request flag field when making a standard event stream request. For details about how to use the Streaming Request message to request events, see [“Sample Extended Request Messages” section on page 2-35](#).
- eStreamer processes the client's Streaming Request message and begins streaming the data at the time specified in the message. For information about the streaming protocol, see [Accepting Data from eStreamer, page 2-5](#).

## Requesting Host Data

Once you have established a session, you can submit a request for host data at any time. eStreamer generates information for the requested hosts from the FireSIGHT System network map.

## Changing a Request

To change request parameters for an established session, the client must disconnect and request a new session.

## Accepting Data from eStreamer



### Note

The eStreamer server does not keep a history of the events it sends. Your client application must check for duplicate events, which can inadvertently occur for a number of reasons. For example, when starting up a new streaming session, the time specified by the client as the starting point for the new session can have multiple messages, some of which may have been sent in the previous session and some of which were not. eStreamer sends all message that meet the specified request criteria. Your application should detect any resulting duplicates.

During periods of inactivity, eStreamer sends periodic null messages to the client to keep the connection open. If it receives an error message from the client or an intermediate host, it closes the connection.

eStreamer transmits requested data to the client differently, depending on the request mode.

## Event Stream Requests

If the client submits an event stream request, eStreamer returns data message by message. It may send multiple messages in a row without waiting for a client acknowledgment. At a certain point, it pauses and waits for the client. The client operating system buffers received data and lets the client process it at its own pace.

If the client request includes a request for metadata, eStreamer sends the metadata first. The client should store it in memory to be available when processing the event records that follow.

## Extended Requests

If the client submits an extended request, eStreamer queues up messages and sends them in bundles. eStreamer may send multiple bundles in a row without waiting for a client acknowledgment. At a certain point, it pauses and waits for the client. The client operating system buffers received data and lets the client read it off at its own pace.

The client unpacks each bundle, message by message, and uses the lengths of the records and the blocks to parse each message. The overall message length in each message header can be used to calculate when the end of each message has been reached, and the overall bundle length can be used to know when the end of the bundle is reached. The bundle requires no index of its contents to be correctly parsed.

For information about the message bundling mechanism, see [“Message Bundle Format” section on page 2-37](#).

For information about the null message that the client can use for additional flow control, see [“Null Message Format” section on page 2-7](#).

## Terminating Connections

The eStreamer server attempts to send an error message before closing the connection. For information on error messages, see [“Error Message Format” section on page 2-8](#).

The eStreamer server can close a client connection for the following reasons:

- Any time sending a message results in an error. This includes both event data messages and the null keep-alive message eStreamer sends during periods of inactivity.
- An error occurs while processing a client request.

- Client authentication fails (no error message is sent).
- eStreamer service is shutting down (no error message is sent).

Your client can close the connection to eStreamer server at any time and should attempt to use the error message format to notify the eStreamer server of the reason.

## Understanding eStreamer Message Types

The eStreamer application protocol uses a simple message format that includes a standard message header and various sub-header fields followed by the record data which contains the message's payload. The message header is the same in all eStreamer message types; for more information, see [eStreamer Message Header, page 2-7](#).

*Table 2-2 eStreamer Message Types*

| Message Type | Name                 | Description  |
|--------------|----------------------|--|
| 0            | Null message         | Both the eStreamer server and the client send null messages to control data flow. For information, see <a href="#">Null Message Format, page 2-7</a> .   |
| 1            | Error message        | Both the eStreamer server and the client use error messages to indicate why a connection closed. For information, see <a href="#">Error Message Format, page 2-8</a> .   |
| 2            | Event Stream Request | A client sends this message type to the eStreamer service to initiate a new streaming session and request data. For information, see <a href="#">Event Stream Request Message Format, page 2-10</a> .                                |
| 4            | Event Data           | The eStreamer service uses this message type to send event data and metadata to the client. For information, see <a href="#">Event Data Message Format, page 2-17</a> .  |
| 5            | Host Data Request    | A client sends this message type to the eStreamer service to request host data. A session must be started already via an Event Stream Request message. For information, see <a href="#">Host Request Message Format, page 2-24</a> . |
| 6            | Single Host Data     | The eStreamer service uses this message type to send single host data requested by the client. For information, see <a href="#">Host Data and Multiple Host Data Message Format, page 2-29</a> .                                     |
| 7            | Multiple Host Data   | The eStreamer service uses this message type to send multiple host data requested by the client. For information, see <a href="#">Host Data and Multiple Host Data Message Format, page 2-29</a> .                                   |
| 2049         | Streaming Request    | A client uses this message type in extended requests to specify which of the advertised events from the Stream Information message it wants. For information, see <a href="#">Sample Extended Request Messages, page 2-35</a> .      |

Table 2-2 eStreamer Message Types (continued)

| Message Type | Name                  | Description   |
|--------------|-----------------------|---|
| 2051         | Streaming Information | The eStreamer service uses this message type in extended requests to advertise the list of services available to the client. For information, see <a href="#">Streaming Information Message Format, page 2-30</a> . |
| 4002         | Message Bundle        | The eStreamer service uses this message type to package messages that it streams to clients. For information, see <a href="#">Message Bundle Format, page 2-37</a> .  |

## eStreamer Message Header

All eStreamer messages start with the message header illustrated in the graphic below. The following table explains the fields.

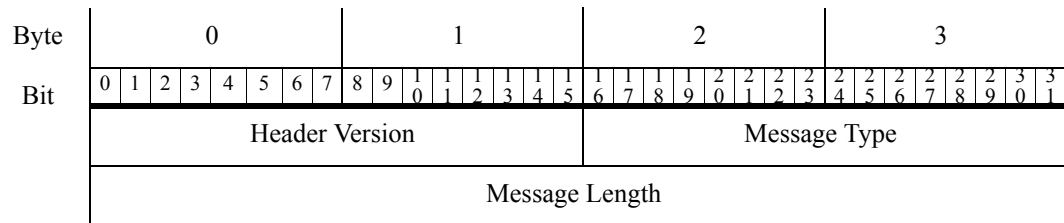

Table 2-3 Standard eStreamer Message Header Fields

| Field          | Data Type | Description  |
|----------------|-----------|--|
| Header Version | uint16    | Indicates the version of the header used on the message. For the current version of eStreamer, this value is always 1.   |
| Message Type   | uint16    | Indicates the type of message transmitted. For the list of current values, see <a href="#">Table 2-2 on page 2-6</a> .   |
| Message Length | uint32    | Indicates the length of the content that follows, and excludes the bytes in the message header itself. A message with a header and no data has a message length of zero. |

## Null Message Format

Both the client application and the eStreamer service send null messages. The null message has a type of 0 and contains no data after the message header.

The client sends a null message to the eStreamer server to indicate readiness to accept more data. The eStreamer service sends null messages to the client to keep the connection alive when no data is being transmitted. The message length value for null messages is always set to 0.

**Tip**

In data structure diagrams in this book, integers in parentheses such as (1) or (115) represent constant field values. For example, Header Version (1) means that the field in the data structure under discussion always has a value of 1.

The Null message format is shown below. The only non-zero value in the message is the header version.

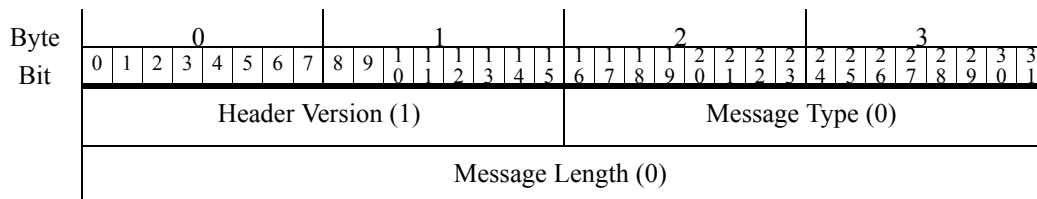

An example of a null message in binary format follows. Notice that the only non-zero value is in the second byte, signifying a header version value of 1. The message type and length fields (shaded) each have a value of 0.

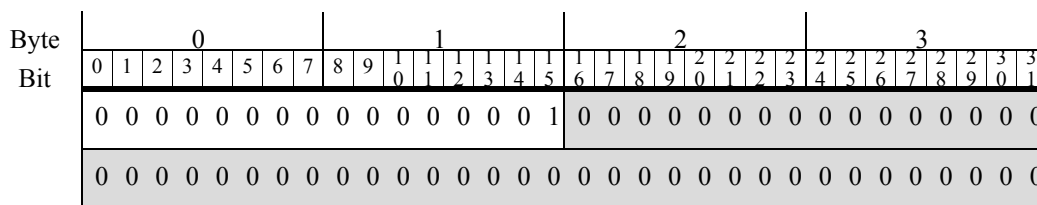
**Tip**

Examples in this guide appear in binary format to clearly display which bits are set. This is important for some messages, such as the event request message and event impact fields.

## Error Message Format

Both the client application and the eStreamer service use error messages. Error messages have a message type of 1 and contain a header, an error code, an error text length, and the actual error text. Error text can contain between 0 and 65,535 bytes.

When you create custom error messages for your client application, Cisco recommends using -1 as the error code.





| Letter | Description  |
|--------|--|
| C      | This line displays the error code. In this example, the message contains a value of 19 (10011). Therefore, error number 19 is transmitted in the message.  |
| D      | This line contains the number of bytes in the error message (1001, or nine bytes), and the error message itself follows in the next nine bytes. The error message value, when converted to ASCII text, equals “No space,” which is the error message that accompanies error code 19. |

## Event Stream Request Message Format

eStreamer clients use the Event Stream Request message to start a streaming session. The request message includes a start time and a bit flag field to specify the data the eStreamer service should include, which can be any combination of events, as well as intrusion event extra data and metadata. The Event Stream Request message can initiate both event stream requests and extended requests. The message type is 2.

You must submit an Event Stream Request message for all data requests, including a request exclusively for host profile information. In such a case, you first submit an Event Stream Request message, then a Host Request message (type 5) to specify the host data.

The following graphic illustrates the Event Stream Request message format. The message uses the standard header. The shaded fields are specific to the request message and are described in the following table.

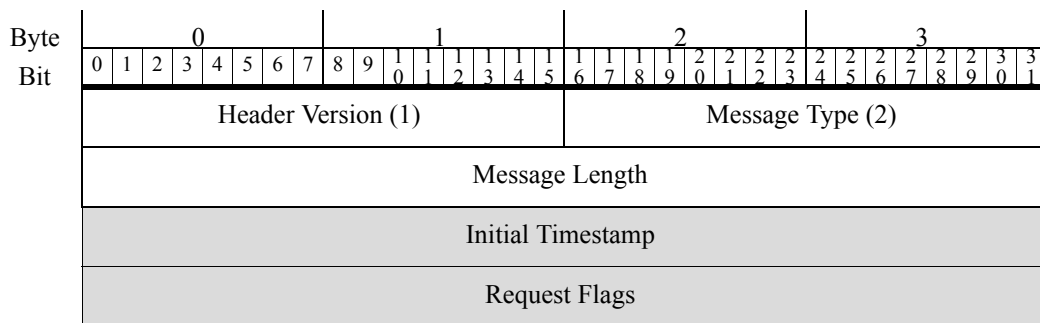

The following table describes each field in Event Stream Request messages.

*Table 2-5 Event Stream Request Message Fields*

| Field             | Data Type | Description  |
|-------------------|-----------|--|
| Initial Timestamp | uint32    | <p>Defines the start of the session. To start at:</p> <ul style="list-style-type: none"> <li>the time the client connects to eStreamer, set all timestamp bits to 1.</li> <li>the oldest data available, set all timestamp bits to zero.</li> <li>a given date and time, specify the UNIX timestamp (number of seconds since January 1, 1970).</li> </ul> <p>See <a href="#">Initial Timestamp</a>, page 2-11 below for important information.</p> |
| Request Flags     | bits[32]  | <p>Specifies the types and versions of events and metadata to be returned in event stream requests. See <a href="#">Request Flags</a>, page 2-11 for flag definitions.</p> <p>Setting bit 30 initiates an extended request, which can co-exist with event stream requests in the same message.</p>   |

## Initial Timestamp



### Note

Your client application should use the archival timestamp in the Initial Timestamp field when submitting an event stream request, as explained below. This ensures that you do not inadvertently exclude events. Devices transmit data to the Defense Center using a “store and forward” mechanism with transmission delays. If you request events by the generation timestamp assigned by the device that detects it, delayed events may be missed.

When starting a session, a best practice is to start up from the archival timestamp (also known as the “server timestamp”) of the last record in the previous session. It is not a technical requirement but is strongly recommended. Under certain circumstances, if you use the generation timestamp you can inadvertently exclude events from the new streaming session.

To include the archival timestamp in your streamed events, you must set bit 23 in the request flag field.

Note that only time-based events have archival timestamps. Events that eStreamer generates, such as metadata, have zero in this field when extended event headers have been requested with bit 23 set.

## Request Flags

You set bits 0 through 29 in the event data request flag field to select the types of events you want eStreamer to send. You set bit 30 to activate the extended request mode. Setting bit 30 does not directly request any data. Extended request flags must be sent if this bit is set. Your client requests data during the server-client message dialog that follows submission of the Event Stream Request message. For information on extended requests, see [Requesting Data from eStreamer](#), page 2-3.

See [Table 2-6 on page 2-12](#) for definitions of the bit settings in the Request Flags field. Different flags request different versions of the event data. For example, to obtain data in FireSIGHT System 4.9 format instead of 4.10 format you set a different flag bit. For specific information on the flags to use when requesting data for particular product versions, see [Table 2-7 on page 2-15](#).

Note that you request metadata by version, not by the individual metadata record. For information about each supported version of metadata, see [Request Flags, page 2-11](#).

The following diagram shades the bits in the flags field that are currently used:

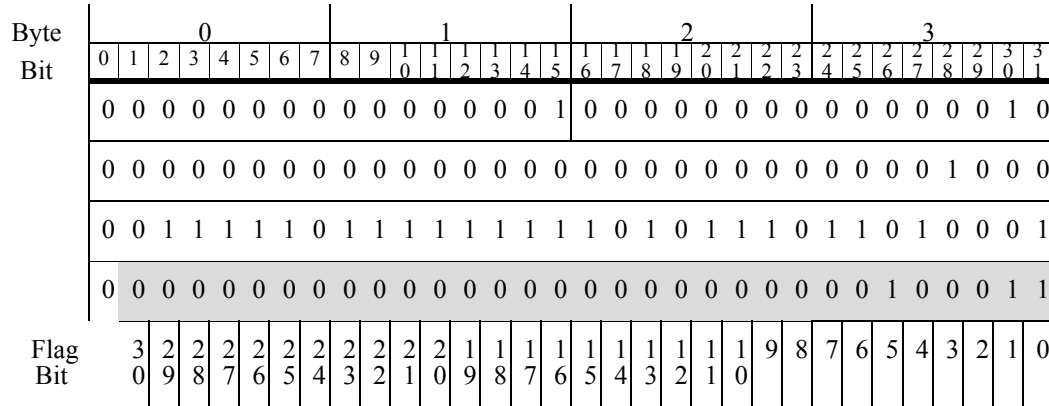

For information on each request flag bit, see the following table.

**Table 2-6** Request Flags

| Bit Field | Description  |
|-----------|--|
| Bit 0     | Requests the transmission of packet data associated with intrusion events. If set to 1, packet data is transmitted with intrusion events. If set to 0, packet data is not transmitted.   |
| Bit 1     | Requests the transmission of version 1 metadata associated with intrusion, discovery, correlation, and connection events. If set to 1, version 1 metadata is transmitted with events. If set to 0, version 1 metadata is not transmitted. You can use metadata to resolve coded and numeric fields in events. See <a href="#">Understanding Metadata, page 2-38</a> for general information on the way eStreamer transmits metadata to clients and how a client can use metadata.  |
| Bit 2     | Requests the transmission of intrusion events. If bit 2, bit 6, or both bit 2 and 6 are set to 1, but the extended request flag, bit 30, is set to 0, the system interprets this as a request from a Version 4.x client and record type 104/105 is sent. If no event type is specified when bit 2, bit 6, or both bit 2 and 6 are set to 1, and bit 30 is set to 1, the system interprets this as a request from a Version 5.0-5.1 client and record type 207/208 is sent. If bit 30 is set to 1, and a specific event type is requested, intrusion events are sent regardless of bits 2 and 6. For details on requesting record types, see <a href="#">Submitting Extended Requests, page 2-4</a> . If bit 2, bit 6, and bit 30 are all set to 0, intrusion events are not sent. Bit 6 is used in a manner identical to bit 2. Either bit can be set to request intrusion events. Setting one of these bits to 0 will not override the other bit; setting bit 2 to 0 and bit 6 to 1, or setting bit 2 to 1 and bit 6 to 0, will be interpreted as a request for intrusion events. |
| Bit 3     | Requests the transmission of discovery data version 1 (Defense Center 3.2). If set to 0, discovery data version 1 is not transmitted. For more information about discovery events, see <a href="#">Understanding Discovery &amp; Connection Data Structures, page 4-1</a> .  |
| Bit 4     | Requests the transmission of correlation data version 1 (Defense Center 3.2). If set to 0, correlation data version 1 is not transmitted.  |

Table 2-6 Request Flags (continued)

| Bit Field | Description   |
|-----------|---|
| Bit 5     | Requests the transmission of impact correlation events (intrusion impact alerts). If set to 1, intrusion impact alerts are transmitted. If set to 0, intrusion impact alerts are not transmitted.<br>See <a href="#">Intrusion Impact Alert Data 5.3+</a> , page 3-12 for more information about intrusion impact alerts.   |
| Bit 6     | Bit 6 is used in a manner identical to bit 2. See <a href="#">Bit 2</a> , page 2-12.  |
| Bit 7     | Requests the transmission of discovery data version 2 (Defense Center 4.0 - 4.1) if set to 1. If set to 0, discovery data version 2 is not transmitted.   |
| Bit 8     | Requests the transmission of connection data version 1 (Defense Center 4.0 - 4.1) if set to 1. If set to 0, connection data version 1 is not sent.  |
| Bit 9     | Requests the transmission of correlation data version 2 (Defense Center 4.0 - 4.1.x) if set to 1. If set to 0, correlation policy data version 2 is not transmitted.  |
| Bit 10    | Requests the transmission of discovery data version 3 (Defense Center 4.5 - 4.6.1) if set to 1. If set to 0, discovery data version 3 is not transmitted.<br>For more information about legacy discovery events, see <a href="#">Legacy Discovery Data Structures</a> , page B-55.  |
| Bit 11    | Disables transmission of events.  |
| Bit 12    | Requests the transmission of connection data version 3 (Defense Center 4.5 - 4.6.1) if set to 1. If set to 0, connection data version 3 is not sent.  |
| Bit 13    | Requests the transmission of correlation data version 3 (Defense Center 4.5 - 4.6.1). If set to 0, correlation data version 3 is not transmitted.   |
| Bit 14    | Requests the transmission of version 2 metadata associated with intrusion, discovery, correlation, and connection events. If set to 1, version 2 metadata is transmitted with events. If set to 0, version 2 metadata is not transmitted.<br>See <a href="#">Understanding Metadata</a> , page 2-38 for general information on the way eStreamer transmits metadata to clients and how a client can use metadata. |
| Bit 15    | Requests the transmission of version 3 metadata associated with intrusion, correlation, discovery, and connection events. If set to 1, version 3 metadata is transmitted with events. If set to 0, version 3 metadata is not transmitted.<br>See <a href="#">Understanding Metadata</a> , page 2-38 for general information on the way eStreamer transmits metadata to clients and how a client can use metadata. |
| Bit 16    | Unused  |
| Bit 17    | Requests the transmission of discovery data version 4 (Defense Center 4.7 - 4.8.x). If set to 0, discovery data version 4 is not transmitted.   |
| Bit 18    | Requests the transmission of connection data version 4 (Defense Center 4.7 - 4.9.0.x) if set to 1. If set to 0, connection data version 4 is not sent. See <a href="#">Connection Chunk Message</a> , page 4-47 for more information.   |
| Bit 19    | Requests the transmission of correlation data version 4 (Defense Center 4.7). If set to 0, correlation data version 4 is not transmitted.<br>See <a href="#">Legacy Correlation Event Data Structures</a> , page B-123 for information about correlation events transmitted in Defense Center 4.7 format.   |

Table 2-6 Request Flags (continued)

| Bit Field | Description  |
|-----------|--|
| Bit 20    | <p>Requests the transmission of version 4 metadata associated with intrusion, discovery, user activity, correlation, and connection events. If set to 1, version 4 metadata is transmitted with events. If set to 0, version 4 metadata is not transmitted.</p> <p>Version 4 metadata includes the following:</p> <ul style="list-style-type: none"> <li>• correlation (compliance) rule information</li> <li>• correlation (compliance) policy information</li> <li>• fingerprint records</li> <li>• client application records</li> <li>• client application type records</li> <li>• vulnerability records</li> <li>• host criticality records</li> <li>• network protocol records</li> <li>• host attribute records</li> <li>• scan type records</li> <li>• user records</li> <li>• service detection device (version 2) records</li> <li>• event classification (version 2) records</li> <li>• priority records</li> <li>• rule information (version 2)</li> <li>• malware information</li> </ul> <p>If you request bit 20 with bit 22, user metadata is also sent.</p> <p>See <a href="#">Understanding Metadata, page 2-38</a> for general information on the way eStreamer transmits metadata to clients and how a client can use metadata.</p> |
| Bit 21    | <p>Requests the transmission of version 1 user events. For more information on user events, see <a href="#">User Record, page 4-18</a>.</p>  |
| Bit 22    | <p>Requests the transmission of correlation data version 5 (Defense Center 4.8.0.2 - 4.9.1). If set to 0, correlation data version 5 is not transmitted.</p> <p>If you request bit 20 with bit 22, user metadata is also sent.</p> <p>For more information about legacy correlation (compliance) events, see <a href="#">Legacy Correlation Event Data Structures, page B-123</a>.</p>   |
| Bit 23    | <p>Requests extended event headers. If set to 1, events are transmitted with the timestamp applied when the event was archived for the eStreamer server to process and four bytes reserved for future use. If this field is set to 0, events are sent with a standard event header that only includes the record type and record length.</p> <p>See <a href="#">eStreamer Message Header, page 2-7</a> for information about the event message header.</p>   |
| Bit 24    | <p>Requests the transmission of discovery data version 5 (Defense Center 4.9.0.x). If set to 0, discovery data version 5 is not transmitted.</p> <p>For more information about discovery events, see <a href="#">Understanding Discovery &amp; Connection Data Structures, page 4-1</a>.</p>   |

Table 2-6 Request Flags (continued)

| Bit Field | Description   |
|-----------|---|
| Bit 25    | Requests the transmission of discovery data version 6 (Defense Center 4.9.1+). If set to 0, discovery data version 6 is not transmitted.<br><br>For more information about discovery events, see <a href="#">Understanding Discovery &amp; Connection Data Structures, page 4-1</a> .                                       |
| Bit 26    | Requests the transmission of connection data version 5 (Defense Center 4.9.1 - 4.10.x) if set to 1. If set to 0, connection data version 5 is not sent. See <a href="#">Connection Chunk Message, page 4-47</a> for more information.   |
| Bit 27    | Requests event extra data associated with an intrusion event in an Extra Data record.<br><br>For more information about event data, see <a href="#">Table 3-11 Intrusion Event Extra Data Data Block Fields, page 3-23</a> .  |
| Bit 28    | Requests the transmission of discovery data version 7 (Defense Center 4.10.0+). If set to 0, discovery data version 7 is not transmitted.<br><br>For more information about discovery events, see <a href="#">Understanding Discovery &amp; Connection Data Structures, page 4-1</a> .                                      |
| Bit 29    | Requests the transmission of correlation data version 6 (Defense Center 4.10 - 4.10.x). If set to 0, correlation policy data version 6 is not transmitted.<br><br>If you request bit 20 with bit 29, user metadata is also sent.<br><br>For more information about correlation events, see earlier versions of the product. |
| Bit 30    | Indicates an extended request to eStreamer. Extended request flags must be sent if this bit is set. For information about extended requests, see <a href="#">Submitting Extended Requests, page 2-4</a> .   |

To help you decide which flags to use to request data for a particular version, see the following table. For Version 5.0 and later, see [Submitting Extended Requests, page 2-4](#) for more information about using Bit 30.

Table 2-7 Event Request Flags by Product Version

| Type of Requested Data | 4.9.0.x | 4.9.1.x | 4.10.x | 5.0+   | 5.1    | 5.1.1+ |
|------------------------|---------|---------|--------|--------|--------|--------|
| packet data            | Bit 0   | Bit 0   | Bit 0  | Bit 0  | Bit 0  | Bit 0  |
| intrusion events       | Bit 2   | Bit 2   | Bit 2  | Bit 2  | Bit 2  | Bit 30 |
| metadata               | Bit 20  | Bit 20  | Bit 20 | Bit 20 | Bit 20 | Bit 20 |
| discovery events       | Bit 24  | Bit 25  | Bit 28 | Bit 30 | Bit 30 | Bit 30 |
| correlation events     | Bit 22  | Bit 22  | Bit 29 | Bit 30 | Bit 30 | Bit 30 |
| event extra data       |         |         | Bit 27 | Bit 27 | Bit 27 | Bit 27 |
| impact event alerts    | Bit 5   | Bit 5   | Bit 5  | Bit 5  | Bit 5  | Bit 5  |
| connection data        | Bit 18  | Bit 26  | Bit 26 | Bit 30 | Bit 30 | Bit 30 |
| user events            | Bit 21  | Bit 21  | Bit 21 | Bit 30 | Bit 30 | Bit 30 |
| malware events         |         |         |        |        |        | Bit 30 |
| file events            |         |         |        |        |        | Bit 30 |



**Caution**

In all event types, prior to version 5.x, the reference client labels detection engine ID fields as sensor ID.

The following example requests intrusion events of type 7 (compatible with FireSIGHT System 3.2+) with both version 1 metadata and packet flags:

|      |   |   |   |   |   |   |   |   |   |   |   |   |   |   |   |   |   |   |   |   |   |   |   |   |   |   |   |   |   |   |   |   |   |   |   |   |
|------|---|---|---|---|---|---|---|---|---|---|---|---|---|---|---|---|---|---|---|---|---|---|---|---|---|---|---|---|---|---|---|---|---|---|---|---|
| Byte | 0 |   |   |   |   |   |   |   | 1 |   |   |   |   |   |   |   | 2 |   |   |   |   |   |   |   | 3 |   |   |   |   |   |   |   |   |   |   |   |
|      | 0 | 1 | 2 | 3 | 4 | 5 | 6 | 7 | 8 | 9 | 0 | 1 | 2 | 3 | 4 | 5 | 6 | 7 | 8 | 9 | 0 | 1 | 2 | 3 | 4 | 5 | 6 | 7 | 8 | 9 | 0 | 1 | 2 | 3 | 4 | 5 |
| Bit  | 0 | 0 | 0 | 0 | 0 | 0 | 0 | 0 | 0 | 0 | 0 | 0 | 0 | 0 | 0 | 1 | 0 | 0 | 0 | 0 | 0 | 0 | 0 | 0 | 0 | 0 | 0 | 0 | 0 | 0 | 0 | 0 | 0 | 0 | 0 | 0 |
|      | 0 | 0 | 0 | 0 | 0 | 0 | 0 | 0 | 0 | 0 | 0 | 0 | 0 | 0 | 0 | 0 | 0 | 0 | 0 | 0 | 0 | 0 | 0 | 0 | 0 | 0 | 0 | 0 | 0 | 0 | 0 | 0 | 0 | 0 | 0 | 0 |
|      | 0 | 0 | 1 | 1 | 1 | 1 | 1 | 0 | 1 | 1 | 1 | 1 | 1 | 1 | 1 | 1 | 1 | 0 | 1 | 0 | 1 | 1 | 1 | 0 | 1 | 1 | 0 | 1 | 1 | 0 | 1 | 0 | 0 | 0 | 0 | 1 |
|      | 0 | 0 | 0 | 0 | 0 | 0 | 0 | 0 | 0 | 0 | 0 | 0 | 0 | 0 | 0 | 0 | 0 | 0 | 0 | 0 | 0 | 0 | 0 | 0 | 0 | 0 | 0 | 0 | 0 | 0 | 0 | 0 | 0 | 0 | 0 | 0 |
| Flag | 3 | 2 | 2 | 2 | 2 | 2 | 2 | 2 | 2 | 2 | 2 | 1 | 1 | 1 | 1 | 1 | 1 | 1 | 1 | 1 | 1 | 1 | 1 | 1 | 1 | 9 | 8 | 7 | 6 | 5 | 4 | 3 | 2 | 1 | 0 |   |
| Bit  | 0 | 9 | 8 | 7 | 6 | 5 | 4 | 3 | 2 | 1 | 0 | 9 | 8 | 7 | 6 | 5 | 4 | 3 | 2 | 1 | 0 | 9 | 8 | 7 | 6 | 5 | 4 | 3 | 2 | 1 | 0 | 9 | 8 | 7 | 6 |   |

To request only data compatible with FireSIGHT System 3.2 (including intrusion events, packets, metadata, impact alerts, policy violation events, and version 2.0 events), use the following:

|      |   |   |   |   |   |   |   |   |   |   |   |   |   |   |   |   |   |   |   |   |   |   |   |   |   |   |   |   |   |   |   |   |   |   |   |   |
|------|---|---|---|---|---|---|---|---|---|---|---|---|---|---|---|---|---|---|---|---|---|---|---|---|---|---|---|---|---|---|---|---|---|---|---|---|
| Byte | 0 |   |   |   |   |   |   |   | 1 |   |   |   |   |   |   |   | 2 |   |   |   |   |   |   |   | 3 |   |   |   |   |   |   |   |   |   |   |   |
|      | 0 | 1 | 2 | 3 | 4 | 5 | 6 | 7 | 8 | 9 | 0 | 1 | 2 | 3 | 4 | 5 | 6 | 7 | 8 | 9 | 0 | 1 | 2 | 3 | 4 | 5 | 6 | 7 | 8 | 9 | 0 | 1 | 2 | 3 | 4 | 5 |
| Bit  | 0 | 0 | 0 | 0 | 0 | 0 | 0 | 0 | 0 | 0 | 0 | 0 | 0 | 0 | 0 | 1 | 0 | 0 | 0 | 0 | 0 | 0 | 0 | 0 | 0 | 0 | 0 | 0 | 0 | 0 | 0 | 0 | 0 | 0 | 0 | 0 |
|      | 0 | 0 | 0 | 0 | 0 | 0 | 0 | 0 | 0 | 0 | 0 | 0 | 0 | 0 | 0 | 0 | 0 | 0 | 0 | 0 | 0 | 0 | 0 | 0 | 0 | 0 | 0 | 0 | 0 | 0 | 0 | 0 | 0 | 0 | 0 | 0 |
|      | 0 | 0 | 1 | 1 | 1 | 1 | 1 | 0 | 1 | 1 | 1 | 1 | 1 | 1 | 1 | 1 | 1 | 0 | 1 | 0 | 1 | 1 | 1 | 0 | 1 | 1 | 0 | 1 | 1 | 0 | 1 | 0 | 0 | 0 | 0 | 1 |
|      | 0 | 0 | 0 | 0 | 0 | 0 | 0 | 0 | 0 | 0 | 0 | 0 | 0 | 0 | 0 | 0 | 0 | 0 | 0 | 0 | 0 | 0 | 0 | 0 | 0 | 0 | 0 | 0 | 0 | 0 | 0 | 0 | 0 | 0 | 0 | 0 |
| Flag | 3 | 2 | 2 | 2 | 2 | 2 | 2 | 2 | 2 | 2 | 2 | 1 | 1 | 1 | 1 | 1 | 1 | 1 | 1 | 1 | 1 | 1 | 1 | 1 | 1 | 9 | 8 | 7 | 6 | 5 | 4 | 3 | 2 | 1 | 0 |   |
| Bit  | 0 | 9 | 8 | 7 | 6 | 5 | 4 | 3 | 2 | 1 | 0 | 9 | 8 | 7 | 6 | 5 | 4 | 3 | 2 | 1 | 0 | 9 | 8 | 7 | 6 | 5 | 4 | 3 | 2 | 1 | 0 | 9 | 8 | 7 | 6 |   |

To request intrusion impact alerts, correlation events, discovery events, connection events, and intrusion events of type 7 with packets and version 3 metadata in Defense Center 4.6.1+ format, use the following:

|      |   |   |   |   |   |   |   |   |   |   |   |   |   |   |   |   |   |   |   |   |   |   |   |   |   |   |   |   |   |   |   |   |   |   |   |   |
|------|---|---|---|---|---|---|---|---|---|---|---|---|---|---|---|---|---|---|---|---|---|---|---|---|---|---|---|---|---|---|---|---|---|---|---|---|
| Byte | 0 |   |   |   |   |   |   |   | 1 |   |   |   |   |   |   |   | 2 |   |   |   |   |   |   |   | 3 |   |   |   |   |   |   |   |   |   |   |   |
|      | 0 | 1 | 2 | 3 | 4 | 5 | 6 | 7 | 8 | 9 | 0 | 1 | 2 | 3 | 4 | 5 | 6 | 7 | 8 | 9 | 0 | 1 | 2 | 3 | 4 | 5 | 6 | 7 | 8 | 9 | 0 | 1 | 2 | 3 | 4 | 5 |
| Bit  | 0 | 0 | 0 | 0 | 0 | 0 | 0 | 0 | 0 | 0 | 0 | 0 | 0 | 0 | 0 | 1 | 0 | 0 | 0 | 0 | 0 | 0 | 0 | 0 | 0 | 0 | 0 | 0 | 0 | 0 | 0 | 0 | 0 | 0 | 0 | 0 |
|      | 0 | 0 | 0 | 0 | 0 | 0 | 0 | 0 | 0 | 0 | 0 | 0 | 0 | 0 | 0 | 0 | 0 | 0 | 0 | 0 | 0 | 0 | 0 | 0 | 0 | 0 | 0 | 0 | 0 | 0 | 0 | 0 | 0 | 0 | 0 | 0 |
|      | 0 | 0 | 1 | 1 | 1 | 1 | 1 | 0 | 1 | 1 | 1 | 1 | 1 | 1 | 1 | 1 | 1 | 0 | 1 | 0 | 1 | 1 | 1 | 1 | 0 | 1 | 1 | 1 | 0 | 1 | 1 | 0 | 0 | 0 | 0 | 1 |



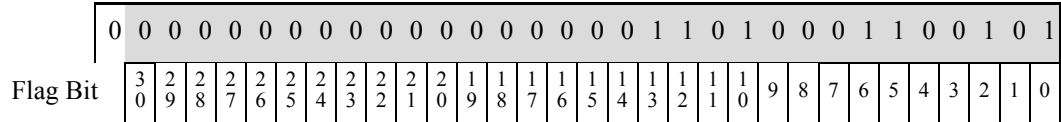

## Event Data Message Format

The eStreamer service transmits event data and related metadata to clients when it receives an event request. Event data messages have a message type of 3. Each message contains a single data record with either event data or metadata.

Note that type 3 messages carry only event data and metadata. eStreamer transmits host information in type 6 (single-host) and type 7 (multiple-host) messages. See [Host Data and Multiple Host Data Message Format, page 2-29](#) for information on host message formats.

## Understanding the Organization of Event Data Messages

The event data and metadata messages that eStreamer sends contain the following sections:

- eStreamer message header — the standard message header defined at [eStreamer Message Header, page 2-7](#).
- Event-specific sub-headers — sets of fields that vary by event type, with codes that describe additional event details and determine the structure of the payload data that follows.
- Data record — fixed-length fields and a data block.



Note

The client should unpack all messages on the basis of field length.

For the event message formats by event type, see the following:

- [Intrusion Event and Metadata Message Format, page 2-18](#) for intrusion event data records and all metadata records. These messages have fixed-length fields.
- [Discovery Event Message Format, page 2-19](#) for messages with discovery event or user event data. In addition to the standard eStreamer message header and a record header similar to the intrusion event message, discovery messages have a distinctive discovery event header with an event type and subtype field. The data record in discovery event messages is packaged in a series 1 block that can have variable length fields and multiple layers of encapsulated blocks.
- [Connection Event Message Format, page 2-20](#) for messages with connection statistics. Their general structure is identical to discovery event messages. Their data block types, however, are specific for connection statistics.
- [Correlation Event Message Format, page 2-20](#) for messages with correlation (compliance) event data. The headers in these messages are the same as in intrusion event messages but the data blocks are series 1 blocks.
- [Event Extra Data Message Format, page 2-22](#) for a series of messages that deliver intrusion-related record types with variable-length fields and multiple layers of nested data blocks such as intrusion event extra data. See [Event Extra Data Message Format, page 2-22](#) for general information on the structure of this message series. See [Data Block Header, page 2-24](#) for information about the structures of this series of blocks which are similar to series 1 blocks but numbered separately.

## Intrusion Event and Metadata Message Format

The graphic below shows the general structure of intrusion event and metadata messages.

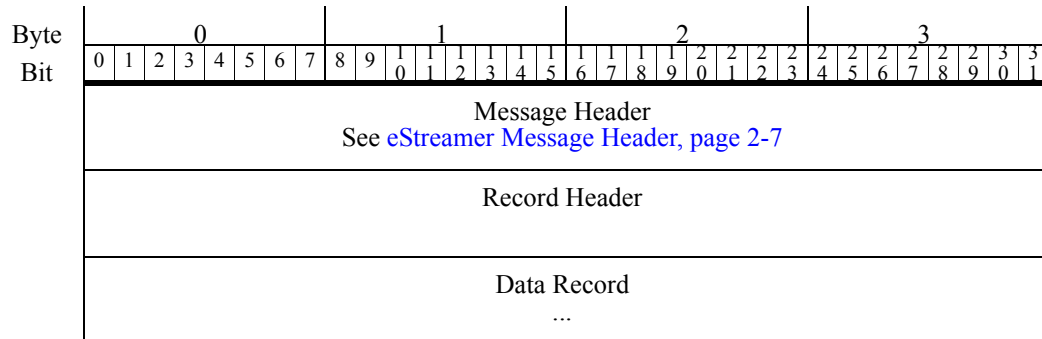

The following graphic shows the details of the record header portion of the intrusion event and metadata message format. The record header fields are shaded. The table that follows defines the fields.

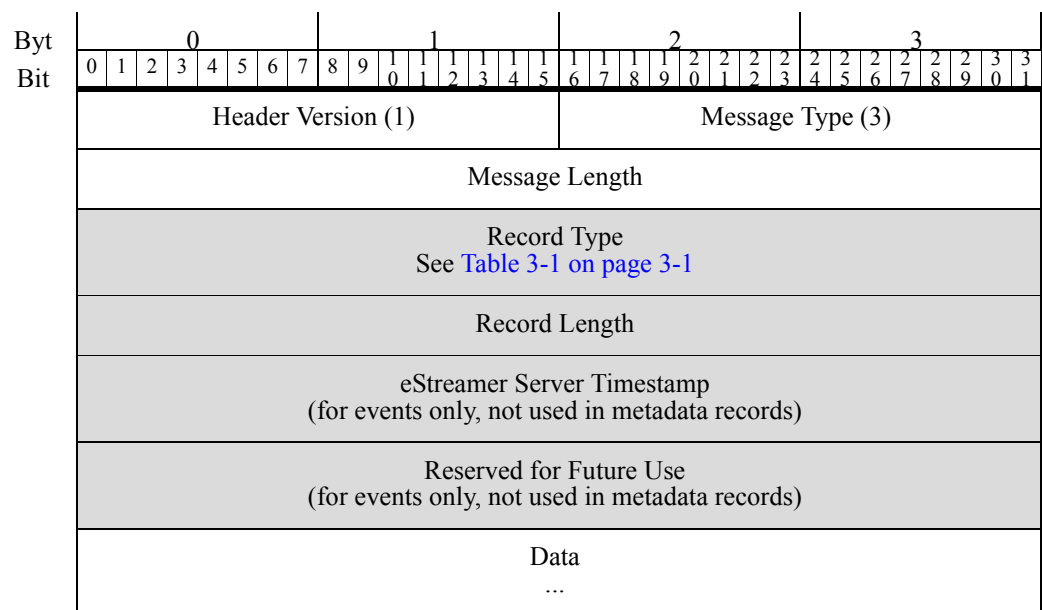

The following table describes each field in the header of intrusion events and metadata messages.

**Table 2-8** Intrusion Event and Metadata Record Header Fields

| Field         | Data Type | Description  |
|---------------|-----------|--|
| Record Type   | uint32    | Identifies the data record content type. See <a href="#">Table 3-1 on page 3-1</a> for the list of record types.   |
| Record Length | uint32    | Length of the content of the message after the record header. Does not include the 8 or 16 bytes of the record header. (Record Length plus the length of the record header equals Message Length.) |

Table 2-8 Intrusion Event and Metadata Record Header Fields (continued)

| Field                      | Data Type | Description   |
|----------------------------|-----------|---|
| eStreamer Server Timestamp | uint32    | Indicates the timestamp applied when the event was archived by the eStreamer server. Also called the archival timestamp.<br>Field present only if bit 23 is set in the request message flags. |
| Reserved for future use    | uint32    | Reserved for future use.<br>Field present only if bit 23 is set in the request message flags.   |

## Discovery Event Message Format

The graphic below shows the structure of discovery event messages. The standard eStreamer message header and event record header are followed by a discovery event header used only in discovery and user event messages. The discovery event header section of the message contains the discovery event type and subtype fields, which together form a key to the data block that follows. For the current discovery event types and subtypes, see [Table 4-26 on page 4-34](#).

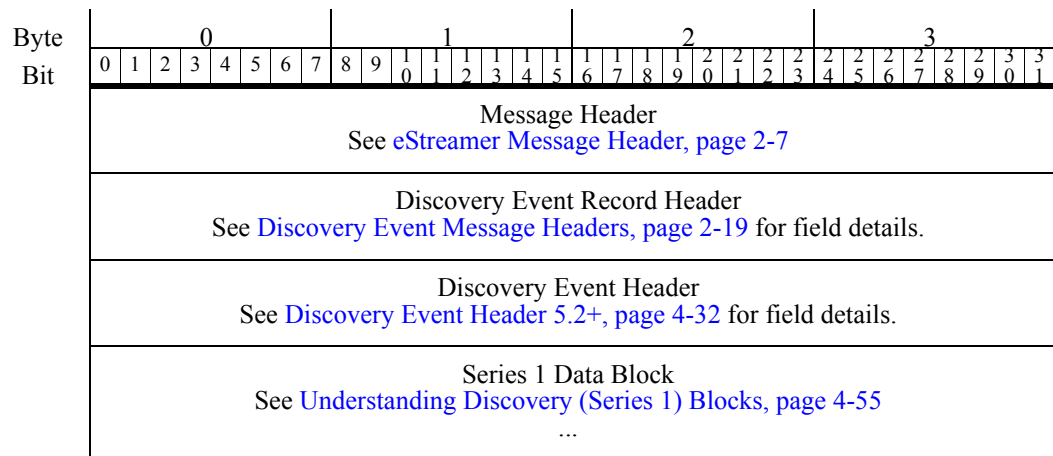

## Discovery Event Message Headers

The shaded section in the following graphic shows the fields of the record header in the discovery event data message format, and shows the location of the event header that follows it. The following table defines the fields of the discovery event message headers.

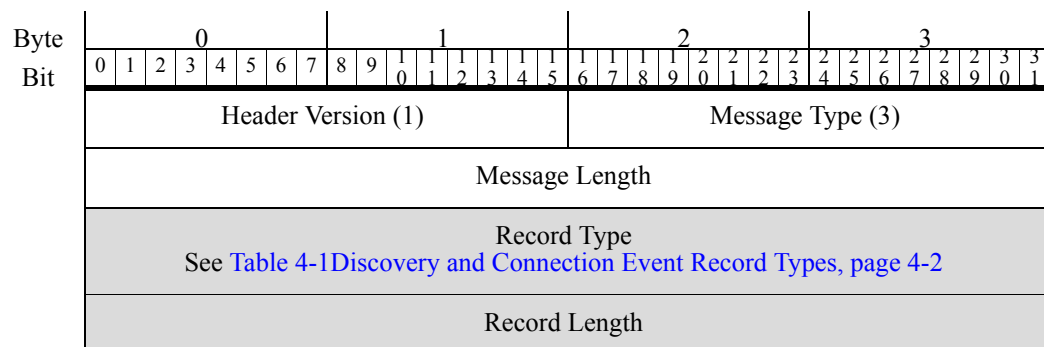

|  |
|--|
| eStreamer Server Timestamp<br>(for events only)  |
| Reserved for Future Use<br>(for events only)   |
| Discovery Event Header<br>See <a href="#">Table 4-25 Discovery Event Header Fields, page 4-33</a>      |
| Series 1 Data Block<br>See <a href="#">Understanding Discovery (Series 1) Blocks, page 4-55</a><br>... |

The following table describes the fields in the record header and the event header of the discovery event message.

**Table 2-9** *Discovery Event Message Header Fields*

| Field                      | Data Type | Description   |
|----------------------------|-----------|---|
| Record Type                | uint32    | Identifies the data record content type. See <a href="#">Table 4-1 on page 4-2</a> for the list of record types.  |
| Record Length              | uint32    | Length of the content of the message after the record header. Does not include the 8 or 16 bytes of the record header. (Record Length plus the length of the record header equals Message Length.)  |
| eStreamer Server Timestamp | uint32    | Indicates the timestamp applied when the event was archived by the eStreamer server. Also called the archival timestamp. Field present only if bit 23 is set in the request flags field of the event stream request.  |
| Reserved for future use    | uint32    | Reserved for future use. Field present only if bit 23 is set in the request message flags.  |
| Discovery Event Header     | Varied    | Contains a number of fields, including the event type and subtype, which together form a unique key to the data structure that follows. See <a href="#">Discovery Event Header 5.2+, page 4-32</a> for definitions of fields in the discovery event header. |

## Connection Event Message Format

Messages with connection statistics have a structure identical to discovery event messages. See [Discovery Event Message Format, page 2-19](#) for general message format information. Connection event messages are distinct in terms of the data block types they incorporate.

## Correlation Event Message Format

The graphic below shows the general structure of correlation (compliance) event messages. The standard eStreamer message header and record header are followed immediately by a data block in the data record section of the message. Correlation messages use Series 1 data blocks.

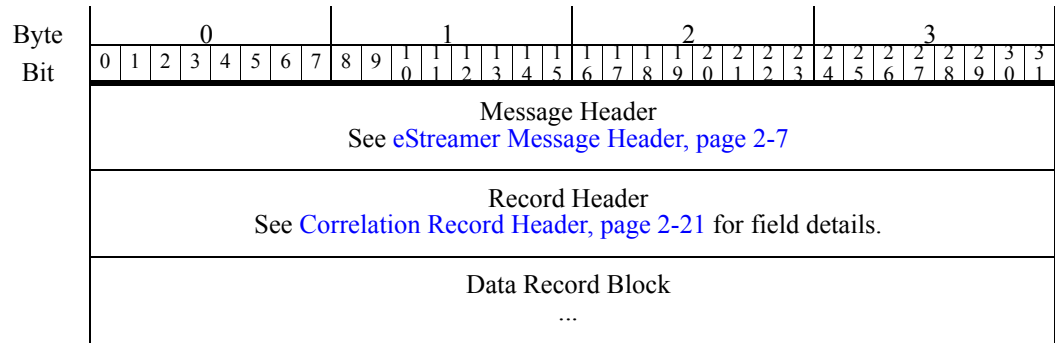

### Correlation Record Header

The shaded section of the following graphic shows the fields of the record header in correlation event messages. Note that correlation messages use series 1 data blocks; however, they do not have the discovery header that appears in discovery event messages. Their header fields resemble those of intrusion event messages. The table that follows the graphic below defines the record header fields for correlation events.

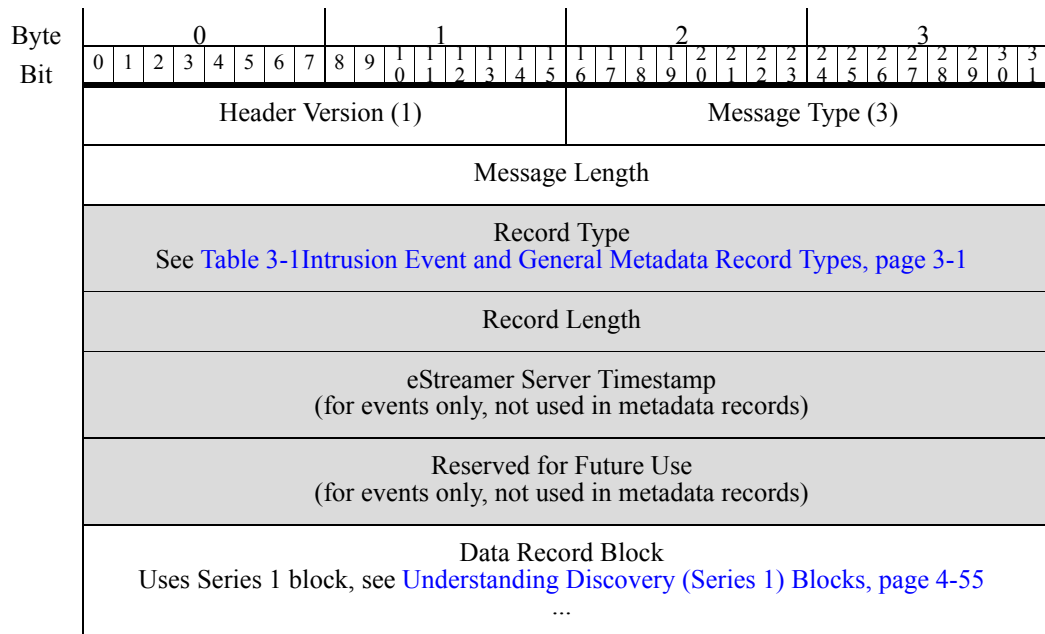

The following table describes each field in the record header of correlation event messages.

**Table 2-10** Correlation Event Message Record Header Fields

| Field                      | Data Type | Description   |
|----------------------------|-----------|---|
| Record Type                | uint32    | Identifies the data record content type. See <a href="#">Table 3-1 on page 3-1</a> for the list of intrusion, correlation, and metadata record types.   |
| Record Length              | uint32    | Length of the content of the message after the record header. Does not include the 8 or 16 bytes of the record header. (Record Length plus the length of the record header equals Message Length.)  |
| eStreamer Server Timestamp | uint32    | Indicates the timestamp applied when the event was archived by the eStreamer server. Also called the archival timestamp.<br>Field present only if bit 23 is set in the request message flags.<br>Field is zero for data generated by the Defense Center such as host profiles and metadata. |
| Reserved for future use    | uint32    | Reserved for future use.<br>Field present only if bit 23 is set in the request message flags.   |

## Event Extra Data Message Format

The graphic below shows the structure of event extra data messages. The Intrusion Event Extra Data message is an example of this message group.

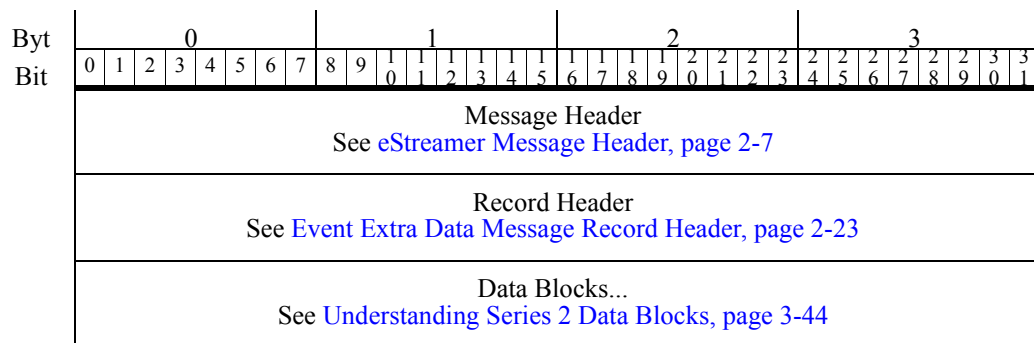

Event extra data messages have the same format as correlation event messages, with a data block directly after the record header. Unlike correlation messages, they use series 2 data blocks, not series 1 data blocks, which have a separate numbering sequence. For information about series 2 block types, see [Understanding Series 2 Data Blocks, page 3-44](#).

## Event Extra Data Message Record Header

The shaded section of the following graphic shows the fields of the record header in event extra data messages. The table that follows defines the record header fields for event extra data messages.

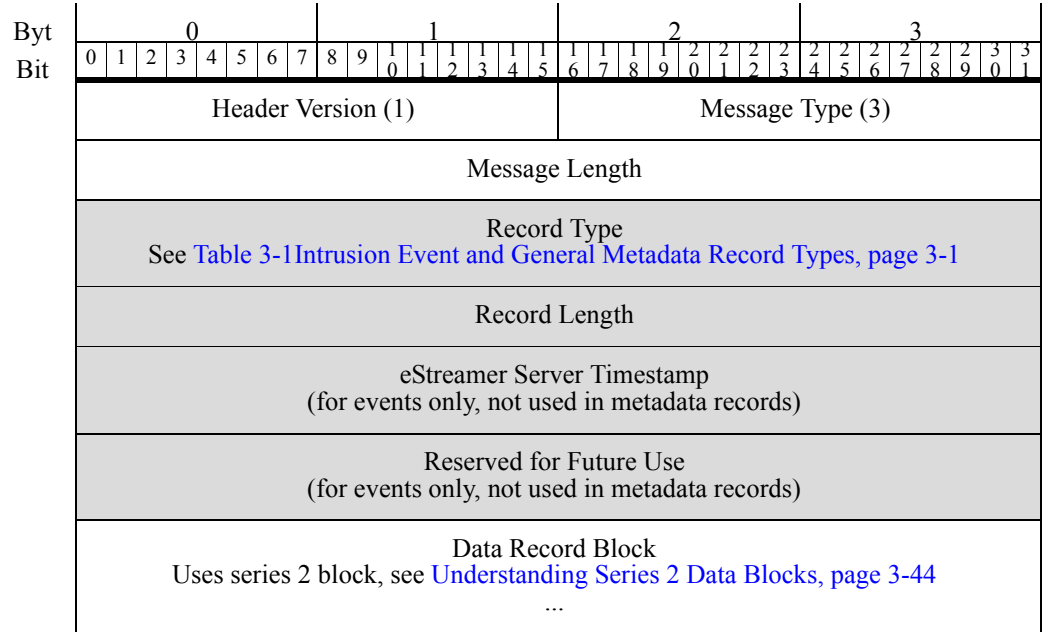

The following table describes each field in the record header of event extra data messages.

**Table 2-11** Event Extra Data Message Record Header Fields

| Field                      | Data Type | Description  |
|----------------------------|-----------|--|
| Record Type                | uint32    | Identifies the data record content type. See <a href="#">Table 3-1 on page 3-1</a> for the list of event extra data record types.  |
| Record Length              | uint32    | Length of the content of the message after the record header. Does not include the 8 or 16 bytes of the record header. (Record Length plus the length of the record header equals Message Length.)   |
| eStreamer Server Timestamp | uint32    | Indicates the timestamp applied when the event was archived by the eStreamer server. Also called the archival timestamp.<br>Field present only if bit 23 is set in the request message flags. Field is not present for events generated by the Defense Center. |
| Reserved for future use    | uint32    | Reserved for future use.<br>Field present only if bit 23 is set in the request message flags. Field is not present for events generated by the Defense Center.   |

## Data Block Header

Series 1 blocks and series 2 blocks have similar structures but distinct numbering. These blocks can appear anywhere in the data portion of a discovery, correlation, connection, or event extra data message. These blocks encapsulate other blocks at multiple levels of nesting.

The data blocks in both the first and second series begin with the header structure shown in the graphic below. The following table provides information about the header fields. The header is followed immediately by the data structure associated with the data block type.

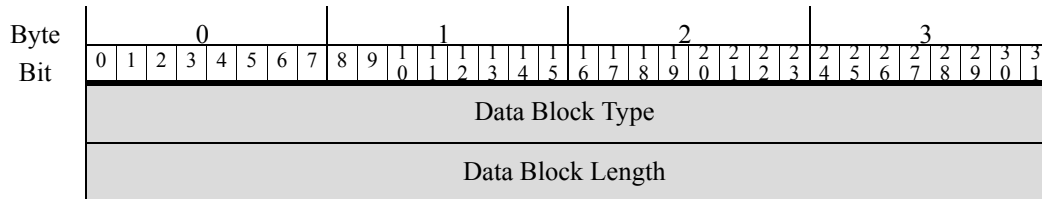

Table 2-12

| Field             | Data Type | Description   |
|-------------------|-----------|---|
| Data Block Type   | uint32    | For series 1 block types, see <a href="#">Understanding Discovery (Series 1) Blocks, page 4-55</a> .<br>For series 2 block types, see <a href="#">Table 3-26 on page 3-45</a> . |
| Data Block Length | uint32    | Length of the data block. Includes the number of bytes of data plus the 8 bytes in the two data block header fields.  |

## Host Request Message Format

To receive host profiles, you submit Host Request messages. You can request data for a single host or multiple hosts defined by an IP address range.

Note that it is mandatory for all data requests, including requests for host profile information, to first initialize the session by submitting an Event Stream Request message. To set up for streaming host data only, you can use any of the following request flag settings in your initial Event Stream Request message:

- set the bit for the appropriate version of metadata (this can be beneficial when streaming host data)
- set no request flags
- set bit 11 (to suppress any default event streaming if using legacy versions of eStreamer)

After the initial message, you then use a Host Request message (type 5) to specify the hosts.



### Note

For legacy eStreamer versions with default event streaming, if you want to stream only host profile data, you must suppress the default event messages. First send the server an Event Stream Request message with bit 11 in the Request Flags field set to 1; then, send the Host Request message.



The graphic below shows the format for the Host Request message. The shaded fields are specific to the Host Request message format and are defined in the following table. The preceding three fields are the standard message header.

|                             |                    |   |   |   |   |   |   |   |   |   |   |   |   |   |   |   |                  |   |   |   |   |   |   |   |   |   |   |   |   |   |   |   |   |
|-----------------------------|--------------------|---|---|---|---|---|---|---|---|---|---|---|---|---|---|---|------------------|---|---|---|---|---|---|---|---|---|---|---|---|---|---|---|---|
| Byte                        | 0                  |   |   |   |   |   |   |   | 1 |   |   |   |   |   |   |   | 2                |   |   |   |   |   |   |   | 3 |   |   |   |   |   |   |   |   |
|                             | 0                  | 1 | 2 | 3 | 4 | 5 | 6 | 7 | 8 | 9 | 0 | 1 | 2 | 3 | 4 | 5 | 6                | 7 | 8 | 9 | 0 | 1 | 2 | 3 | 4 | 5 | 6 | 7 | 8 | 9 | 0 | 1 | 2 |
| Bit                         | Header Version (1) |   |   |   |   |   |   |   |   |   |   |   |   |   |   |   | Message Type (5) |   |   |   |   |   |   |   |   |   |   |   |   |   |   |   |   |
| Message Length              |                    |   |   |   |   |   |   |   |   |   |   |   |   |   |   |   |                  |   |   |   |   |   |   |   |   |   |   |   |   |   |   |   |   |
| Data Type                   |                    |   |   |   |   |   |   |   |   |   |   |   |   |   |   |   |                  |   |   |   |   |   |   |   |   |   |   |   |   |   |   |   |   |
| Flags                       |                    |   |   |   |   |   |   |   |   |   |   |   |   |   |   |   |                  |   |   |   |   |   |   |   |   |   |   |   |   |   |   |   |   |
| Start IP Address            |                    |   |   |   |   |   |   |   |   |   |   |   |   |   |   |   |                  |   |   |   |   |   |   |   |   |   |   |   |   |   |   |   |   |
| Start IP Address, continued |                    |   |   |   |   |   |   |   |   |   |   |   |   |   |   |   |                  |   |   |   |   |   |   |   |   |   |   |   |   |   |   |   |   |
| Start IP Address, continued |                    |   |   |   |   |   |   |   |   |   |   |   |   |   |   |   |                  |   |   |   |   |   |   |   |   |   |   |   |   |   |   |   |   |
| Start IP Address, continued |                    |   |   |   |   |   |   |   |   |   |   |   |   |   |   |   |                  |   |   |   |   |   |   |   |   |   |   |   |   |   |   |   |   |
| End IP Address              |                    |   |   |   |   |   |   |   |   |   |   |   |   |   |   |   |                  |   |   |   |   |   |   |   |   |   |   |   |   |   |   |   |   |
| End IP Address, continued   |                    |   |   |   |   |   |   |   |   |   |   |   |   |   |   |   |                  |   |   |   |   |   |   |   |   |   |   |   |   |   |   |   |   |
| End IP Address, continued   |                    |   |   |   |   |   |   |   |   |   |   |   |   |   |   |   |                  |   |   |   |   |   |   |   |   |   |   |   |   |   |   |   |   |
| End IP Address, continued   |                    |   |   |   |   |   |   |   |   |   |   |   |   |   |   |   |                  |   |   |   |   |   |   |   |   |   |   |   |   |   |   |   |   |

The following table explains the message fields.

**Table 2-13** *Host Request Message Fields*

| Field            | Data Type    | Description   |
|------------------|--------------|---|
| Data Type        | uint32       | <p>Requests data for a single host or multiple hosts, using the following codes:</p> <ul style="list-style-type: none"> <li>• 0 — version 3.5 - 4.6 for a single host.</li> <li>• 1 — version 3.5 - 4.6 for multiple hosts (uses block 34).</li> <li>• 2 — version 4.7 - 4.8 for a single host (uses block 47).</li> <li>• 3 — version 4.7 - 4.8 for multiple hosts (uses block 47).</li> <li>• 4 — version 4.9 - 4.10 for a single host (uses block 92).</li> <li>• 5 — version 4.9 - 4.10 for multiple hosts (uses block 92).</li> <li>• 6 — Version 5.0.x data for a single host (uses block 111, see <a href="#">Full Host Profile Data Block 5.0 - 5.0.2, page B-131</a>).</li> <li>• 7 — Version 5.0.x data for multiple hosts (uses block 111, see <a href="#">Full Host Profile Data Block 5.0 - 5.0.2, page B-131</a>).</li> <li>• 8 — Version 5.1.x data for multiple hosts (uses block 111, see <a href="#">Full Host Profile Data Block 5.1.1, page B-140</a>).</li> <li>• 9 — Version 5.1.x data for multiple hosts (uses block 111, see <a href="#">Full Host Profile Data Block 5.1.1, page B-140</a>).</li> <li>• 10 — Rule documentation data (uses block 27, see <a href="#">Rule Documentation Message Format, page 2-28</a>).</li> <li>• 11 — Version 5.2x data for multiple hosts (uses block 111, see <a href="#">Full Host Profile Data Block 5.2.x, page B-149</a>).</li> <li>• 12 — Version 5.2.x data for multiple hosts (uses block 111, see <a href="#">Full Host Profile Data Block 5.2.x, page B-149</a>).</li> <li>• 13 — Version 5.3+ data for multiple hosts (uses block 111, see <a href="#">Full Host Profile Data Block 5.3+, page 5-1</a>).</li> <li>• 14 — Version 5.3+ data for multiple hosts (uses block 111, see <a href="#">Full Host Profile Data Block 5.3+, page 5-1</a>).</li> </ul> |
| Flags            | 32-bit field | <ul style="list-style-type: none"> <li>• 0x00000001 — Causes the Notes field of the host profile to be populated (with user-defined information about the host stored in the FireSIGHT System).</li> <li>• 0x00000002 — Causes the Banner field of the service block to be populated (with the first 256 bytes of the first packet detected for the service). Banners are disabled by default and available only if configured.</li> </ul>  |
| Start IP Address | uint8[16]    | IP address of the host whose data should be returned (if request is for a single host), or the starting address in an IP address range (if request is for multiple hosts). Can be either an IPv4 or IPv6 address.   |
| End IP Address   | uint8[16]    | Ending address in an IP address range (if request is for multiple hosts), or the Start IP Address value (if request is for single host). Can be either an IPv4 or IPv6 address.   |

The graphic below shows the format for the legacy Host Request message. eStreamer will still respond to this request. The only difference from the current request is the smaller IPv4 address fields. The shaded fields are specific to the Host Request message format and are defined in the following table. The preceding three fields are the standard message header.

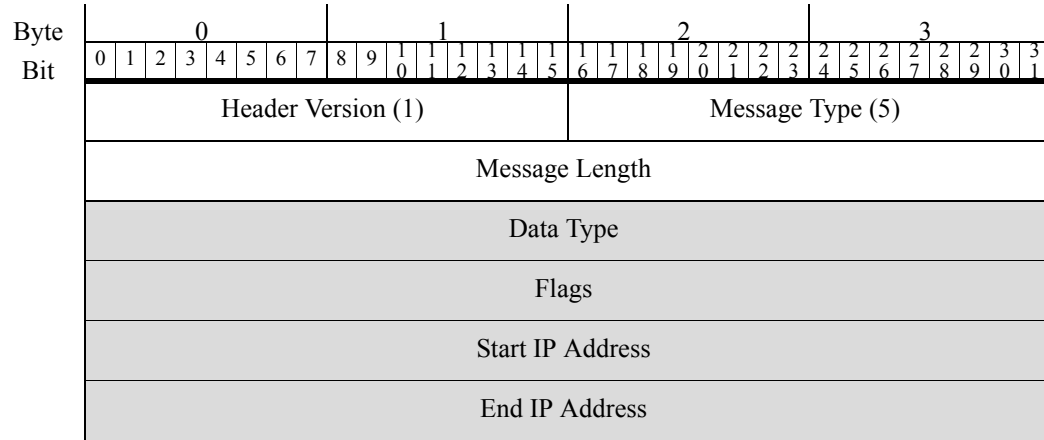

The following table explains the message fields.

**Table 2-14** Host Request Message Fields

| Field     | Data Type    | Description  |
|-----------|--------------|--|
| Data Type | uint32       | Requests data for a single host or multiple hosts, using the following codes: <ul style="list-style-type: none"> <li>0 — version 3.5 - 4.6 for a single host.</li> <li>1 — version 3.5 - 4.6 for multiple hosts (uses block 34).</li> <li>2 — version 4.7 - 4.8 for a single host (uses block 47).</li> <li>3 — version 4.7 - 4.8 for multiple hosts (uses block 47).</li> <li>4 — version 4.9 - 4.10 for a single host (uses block 92).</li> <li>5 — version 4.9 - 4.10 for multiple hosts (uses block 92).</li> <li>6 — version 5.0+ data for a single host (uses block 111, see <a href="#">Full Host Profile Data Block 5.3+</a>, page 5-1).</li> <li>7 — version 5.0+ data for multiple hosts (uses block 111, see <a href="#">Full Host Profile Data Block 5.3+</a>, page 5-1).</li> </ul> |
| Flags     | 32-bit field | <ul style="list-style-type: none"> <li>0x00000001 — Causes the Notes field of the host profile to be populated (with user-defined information about the host stored in the FireSIGHT System).</li> <li>0x00000002 — Causes the Banner field of the service block to be populated (with the first 256 bytes of the first packet detected for the service). Banners are disabled by default and available only if configured.</li> </ul>   |

Table 2-14 Host Request Message Fields (continued)

| Field            | Data Type | Description  |
|------------------|-----------|--|
| Start IP Address | uint8[4]  | IP address of the host whose data should be returned (if request is for a single host), or the starting address in an IP address range (if request is for multiple hosts). Specify the address in IP address octets. |
| End IP Address   | uint8[4]  | Ending address in an IP address range (if request is for multiple hosts), or the Start IP Address value (if request is for single host).   |

## Rule Documentation Message Format

To receive rule documentation profiles, you submit Rule Documentation messages. You request these by generator ID, signature ID, and revision.

Note that it is mandatory for all data requests, including requests for rule documentation information, to first initialize the session by submitting an Event Stream Request message. To set up for streaming host data only, you can use any of the following request flag settings in your initial Event Stream Request message:

- set the bit for the appropriate version of metadata (this can be beneficial when streaming host data)
- set no request flags
- set bit 11 (to suppress any default event streaming if using legacy versions of eStreamer)

After the initial message, you then use a Rule Documentation message (type 10) to specify the rule.



### Note

For legacy eStreamer versions with default event streaming, if you want to stream only host profile data, you need to suppress the default event messages. First send the server an Event Stream Request message with bit 11 in the Request Flags field set to 1; then, send the Host Request message.

The graphic below shows the format for the Rule Documentation message. The shaded fields are specific to the Rule Documentation message format and are defined in the following table. The preceding three fields are the standard message header.

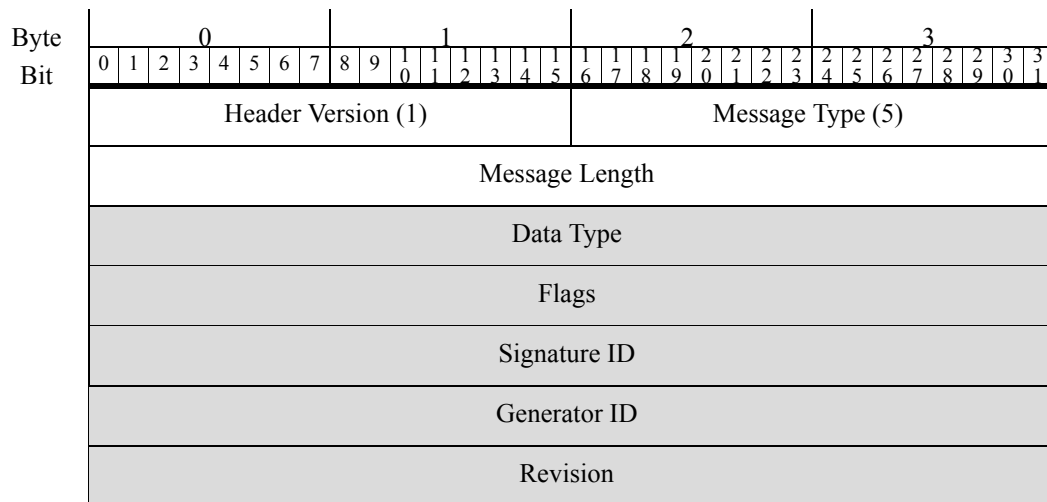

|                     |
|---------------------|
| Reserved            |
| Reserved, continued |
| Reserved, continued |
| Reserved, continued |
| Reserved, continued |

The following table explains the message fields.

**Table 2-15** *Rule Documentation Message Fields*

| Field         | Data Type    | Description  |
|---------------|--------------|--|
| Data Type     | uint32       | Requests data for a Rule Documentation Data Block. This value is always 10. See <Xref_Color>Rule Documentation Data Block for 5.2+, page 3-74.   |
| Flags         | 32-bit field | <ul style="list-style-type: none"> <li>0x00000001 — Causes the Notes field of the host profile to be populated (with user-defined information about the host stored in the Firepower System).</li> <li>0x00000002 — Causes the Banner field of the service block to be populated (with the first 256 bytes of the first packet detected for the service). Banners are disabled by default and available only if configured.</li> </ul> |
| Signature ID  | uint32       | Identification number of the requested rule.   |
| Generator ID  | uint32       | Identification number of the Firepower System preprocessor for the requested rule.   |
| Rule Revision | uint32       | Rule revision number.  |
| Reserved      | uint8[20]    | This field is not currently used.  |

## Host Data and Multiple Host Data Message Format

eStreamer responds to host requests by sending host data messages, each with a full host profile data block. eStreamer sends one host data message for each host specified in the request. eStreamer uses the type 6 message to respond to requests for a single host profile, and uses the type 7 message to respond to requests for multiple hosts. The formats of the type 6 and type 7 messages are identical, only the message type is different.

Host data messages do not have a record type field. The structure of the message is communicated by the message type and the data block type of the full host profile included in the message. Full host profile data blocks are in the series a group of blocks.

The graphic below shows the format of the host data message and the table that follows defines the shaded fields:

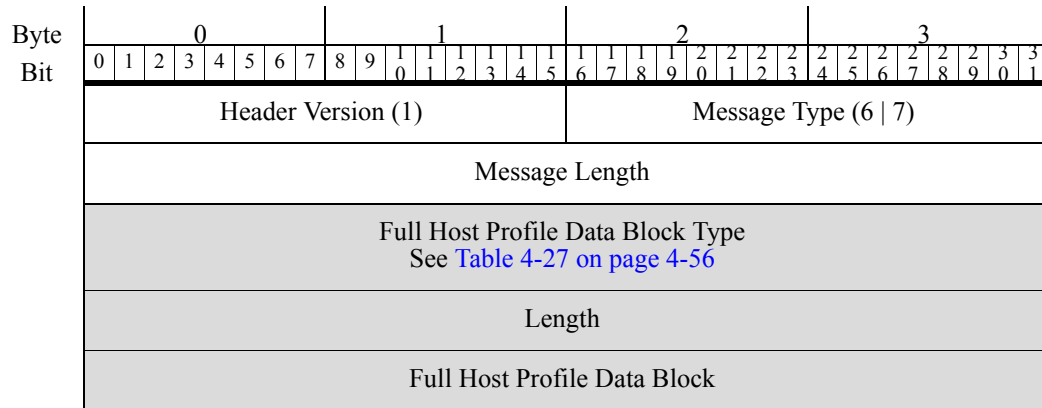

The fields specific to the Host Request message are:

**Table 2-16**

| Field                             | Data Type | Description   |
|-----------------------------------|-----------|---|
| Full Host Profile Data Block Type | uint32    | Specifies the block type for the full host profile data included in the message. See <a href="#">Table 4-27 on page 4-56</a> .      |
| Length                            | uint32    | Length of the full host profile data in the message.  |
| Full Host Profile Data Block      | variable  | The host data. For links to the definitions of current full host profile data blocks, see <a href="#">Table 4-27 on page 4-56</a> . |

## Streaming Information Message Format

When the eStreamer service receives a request for an extended request, it sends the client the Streaming Information message described below. This message advertises the server's list of available services. Currently, the only relevant option is the eStreamer service (6667), although the message can list other services, which should be ignored. Each advertised service is represented by a Streaming Service Request structure described in [Table 2-18 on page 2-32](#).

The graphic below illustrates the format for the Streaming Information message. The shaded field is specific to this message type. The preceding three fields are the standard message header.

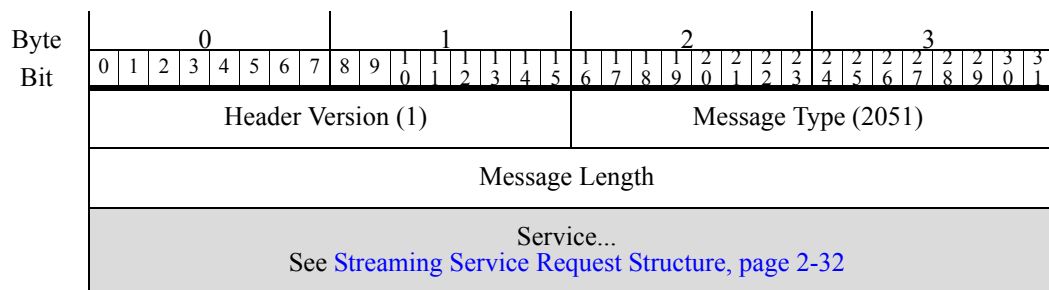

The fields of the Streaming Information message are:

**Table 2-17** Streaming Information Message Fields

| Field          | Data Type | Description   |
|----------------|-----------|---|
| Header Version | uint16    | Set to 1.   |
| Message Type   | uint16    | eStreamer message type. Set to 2051 for Streaming Request messages.   |
| Message Length | uint32    | Length of the content of the message after the message header. Does not include the bytes in the Header Version, Message Type, and Message Length fields. |
| Service[]      | array     | List of available services. See <a href="#">Streaming Service Request Structure, page 2-32</a> .  |

## Streaming Request Message Format

The client uses the Streaming Request message to specify to eStreamer the service in the Streaming Information message that it wants to use, followed by a set of requests for event types and versions to be streamed. The graphic below shows the message structure and the following table defines the fields. The requested service is represented by a Streaming Service Request structure described in [Table 2-18 on page 2-32](#).

The graphic below illustrates the format for the Streaming Information message. The shaded field is specific to this message type. The preceding three fields are the standard message header.

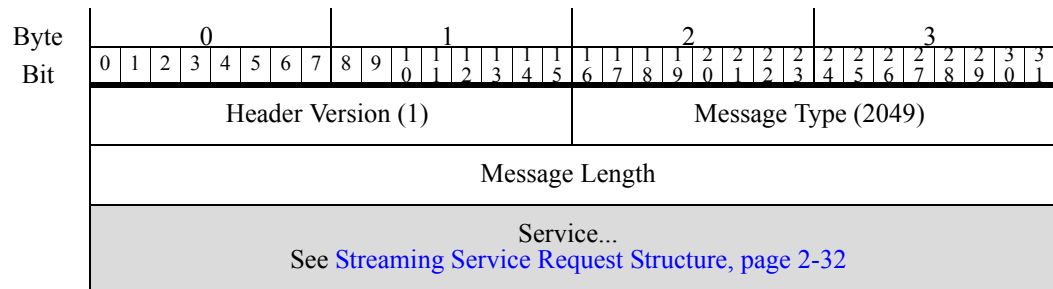

The fields of the Streaming Request message are:

**Table 2-18** Streaming Request Message Fields

| Field          | Data Type | Description   |
|----------------|-----------|---|
| Header Version | uint16    | Set to 1.   |
| Message Type   | uint16    | eStreamer message type. Set to 2049 for Streaming Request messages.   |
| Message Length | uint32    | Length of the content of the message after the message header. Does not include the bytes in the Header Version, Message Type, and Message Length fields. |
| Service[]      | array     | List of requested service structures. See <a href="#">Streaming Service Request Structure, page 2-32</a> .  |

## Streaming Service Request Structure

The eStreamer service sends one Streaming Service Request data structure in the Streaming Information message for each service it advertises. The eStreamer service does not use the last field of the Streaming Service Request, which provides for a list of event types to be included.

The client processes the Streaming Service Request structure from eStreamer and uses the same structure in the response it returns to the server. In the Streaming Service Request that the client sends to the server, it includes, first, a request for the service advertised by eStreamer, and, second, a list of Streaming Event Type structures, which specify the requested event types the client wants to receive.

Each Streaming Event Type structure contains two fields to specify the event type and version for each requested event type. For information on the Streaming Event Type structure, see [Streaming Event Type Structure, page 2-33](#).

The graphic below shows the fields of the Streaming Service Request structure. The table that follows defines the fields.

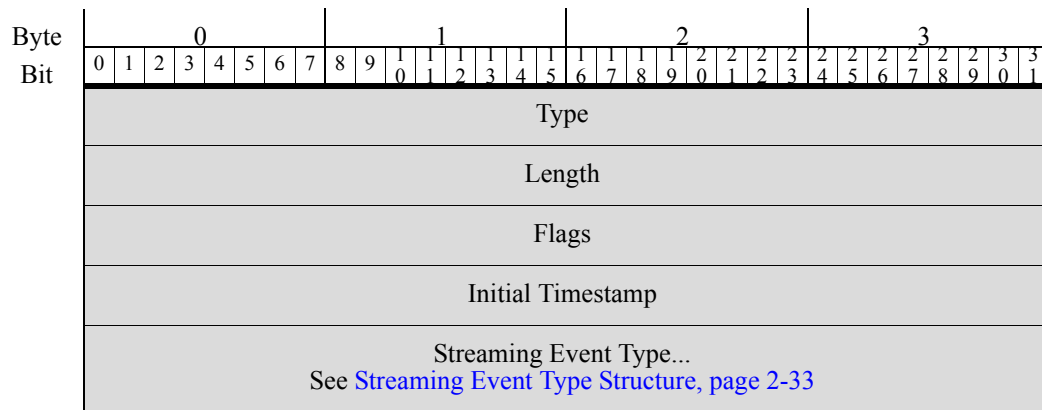

The fields of the Streaming Service Request structure are:

**Table 2-19** Streaming Service Request Fields

| Field  | Data Type | Description  |
|--------|-----------|--|
| Type   | uint32    | Service ID.<br>In eStreamer server messages, this advertises an available service.<br>In client messages, it specifies a requested service.<br>Current valid options: <ul style="list-style-type: none"> <li>6667 (for eStreamer service)</li> </ul> |
| Length | uint32    | Service request length. Describes the length of the fields following Length.<br>Note that Length must include all the Streaming Event Type records in the message, plus the terminating one.   |



Table 2-19 Streaming Service Request Fields (continued)

| Field                | Data Type | Description  |
|----------------------|-----------|--|
| Flags                | uint32    | In eStreamer's Streaming Information messages: Always 0.<br>In client's Streaming Request message: replicates the flag settings in the original Event Stream Request message.  |
| Initial Timestamp    | uint32    | In eStreamer's Streaming Information messages: Always 0.<br>In client's Streaming Request message: replicates the timestamp in the original Event Stream Request message.  |
| Streaming Event Type | array     | In eStreamer's Streaming Information message: <ul style="list-style-type: none"> <li>Reserved for future use. Has 0 length.</li> </ul> In client's Streaming Request message: <ul style="list-style-type: none"> <li>One Streaming Event Type entry for each requested event type. See <a href="#">Streaming Event Type Structure, page 2-33</a>.</li> <li>Terminate the request list with a 0 Event Type entry, with both Event Type and Version set to 0.</li> </ul> See <a href="#">Streaming Event Type Structure, page 2-33</a> . |

## Streaming Event Type Structure

eStreamer clients use the Streaming Event Type structure to specify an event's version and version. Each event version/type combination is a request for an event stream.

Lists of Streaming Event Type structures must be terminated with a structure with all fields set to zero. That is:

```
Event Version = 0
Event Type = 0
```

The following diagram illustrates the format for the Streaming Event Type structure.

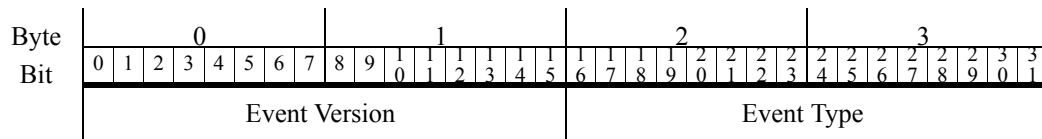

The fields of the Streaming Event Type structure are:

**Table 2-20** *Streaming Event Type Fields*

| Field         | Data Type | Description  |
|---------------|-----------|--|
| Event Version | uint16    | Version number of event type. For list of versions supported for each event type, see <a href="#">Table 2-21 on page 2-34</a> .  |
| Event Type    | uint16    | Code for requested event type. For the current list of valid event types and version codes, see <a href="#">Table 2-21 on page 2-34</a> .<br><br>List of event types should be terminated with a zero event type and zero event version. |

The following table lists the event types and versions that clients can specify in extended requests. The table indicates the Defense Center software versions that correspond to each event type version. For example, to request the correlation events that were supported by the Defense Center in version 4.8.0.2 - 4.9.1, you should request Event Type 31, Version 5. If an event was recorded with a different event type, it will be upgraded or downgraded to match the format of the requested event type.

**Table 2-21** *Event Types and Versions for Extended Request*

| To request...                                | Use this event version number...  | And this event code |
|--|---|---------------------|
| intrusion events                             | 1 - 4.8.x and earlier<br>2 - 4.9 - 4.10.x<br>3 - 5.0 - 5.1<br>4 - 5.1.1.x<br>5 - 5.2.x<br>6 - 5.3<br>7 - 5.3.1+   | 12                  |
| metadata                                     | 1 - 3.2 - 4.5.x<br>2 - 4.6.0.x<br>3 - 4.6.1 - 4.6.x<br>4 - 4.7+   | 21                  |
| correlation and compliance white list events | 1 - 3.2 and earlier<br>2 - 4.0 - 4.4.x<br>3 - 4.5 - 4.6.1<br>4 - 4.7 - 4.8.0.1<br>5 - 4.8.0.2 - 4.9.1.x<br>6 - 4.10.0 - 4.10.x<br>7 - 5.0 - 5.0.2<br>8 - 5.1+ | 31                  |

Table 2-21 Event Types and Versions for Extended Request (continued)

| To request...                    | Use this event version number...   | And this event code |
|----------------------------------|--|---------------------|
| discovery events                 | 1 - 3.2 and earlier<br>2 - 3.0 - 3.4.x<br>3 - 3.5 - 4.6.x<br>4 - 4.7 - 4.8.x<br>5 - 4.9.0.x<br>6 - 4.9.1 - 4.9.x.x<br>7 - 4.10.0 - 4.10.x<br>8 - 5.0.x<br>9 - 5.1.x<br>10 - 5.2 - 5.3<br>11 - 5.3.1+ | 61                  |
| connection events                | 1 - 4.0 - 4.1<br>3 - 4.5 - 4.6.1<br>4 - 4.7 - 4.9.0.x<br>5 - 4.9.1 - 4.10.x<br>6 - 5.0.x<br>7 - 5.1.0.x<br>8 - 5.1.1.x<br>9 - 5.2.x<br>10 - 5.3<br>11 - 5.3.1+                                       | 71                  |
| user events                      | 1 - 4.7 - 4.10.x<br>2 - 5.0.x<br>3 - 5.1-5.1.x<br>4 - 5.2+   | 91                  |
| malware events                   | 1 - 5.1.0.x<br>2 - 5.1.1.x<br>3 - 5.2.x<br>4 - 5.3<br>5 - 5.3.1+   | 101                 |
| file events                      | 1 - 5.1.1 - 5.1.x<br>2 - 5.2.x<br>3 - 5.3<br>4 - 5.3.1+  | 111                 |
| impact correlation events        | 1 - 5.2.x and earlier<br>2 - 5.3+  | 131                 |
| terminating event type in a list | 0  | 0                   |

## Sample Extended Request Messages

The following samples show how eStreamer advertises services, and how the client requests services from the eStreamer server.

## Streaming Information Message

In the sample below, the server advertises two services, the first type 6667 (eStreamer) and the second type 5000. In Streaming Information messages from the server, the flags field and initial timestamp fields are zero, and the message specifies no event types.

Table 2-22

|                              |      |                          |
|------------------------------|------|--------------------------|
| Header Version:              | 1    | /*always 1*/             |
| Message Type:                | 2051 | /*streaming info msg*/   |
| Message Length               | 32   | /*bytes of msg content*/ |
| Service[1].Type              | 6667 | /*eStreamer service ID*/ |
| Service[1].Length            | 8    |                          |
| Service[1].Flags             | 0    | /*no flags from server*/ |
| Service[1].Initial Timestamp | 0    | /*always 0*/             |
| Service[2].Type              | 5000 | /*service-2 ID*/         |
| Service[2].Length            | 8    |                          |
| Service[2].Flags             | 0    | /*no flags from server*/ |
| Service[2].Initial Timestamp | 0    | /*always 0*/             |
| Header Version:              | 1    | /*always 1*/             |
| Message Type:                | 2051 | /*streaming info msg*/   |

## Streaming Request Message

Below is a Streaming Request message where the client requests service type 6667 (eStreamer) and specifies two event types: version 6 of connection events (event type 71) and version 4 of metadata (event type 21).

Table 2-23

|                              |      |                          |
|------------------------------|------|--------------------------|
| Header Version:              | 1    | /*always 1*/             |
| Message Type:                | 2049 | /*stream request msg*/   |
| Message Length               | 28   | /*payload bytes*/        |
| Service[1].Type              | 6667 | /*eStreamer service ID*/ |
| Service[1].Length            | 20   |                          |
| Service[1].Flags             | 30   | /*original flags value*/ |
| Service[1].Initial Timestamp | 0    | /*original timestamp*/   |
| Service[1].Event[1].Version  | 6    | /*version 6*/            |
| Service[1].Event[1].Type     | 71   | /*connection events*/    |
| Service[1].Event[2].Version  | 4    | /*version 4*/            |
| Service[1].Event[2].Type     | 21   | /*metadata*/             |

Table 2-23

|                             |   |                          |
|-----------------------------|---|--------------------------|
| Service[1].Event[3].Version | 0 | /*terminate event list*/ |
| Service[1].Event[3].Type    | 0 | /*terminate event list*/ |

## Message Bundle Format

The eStreamer server sends messages in a bundle format when the client submits an extended request. The client responds with a null message to acknowledge receipt of an entire bundle. The client should not acknowledge receipt of individual messages in a bundle.

Message bundles have a message type of 4002.

The graphic below shows the structure of a message bundle. The shaded fields are specific to the bundle message type. The following table describes the content of the fields and data structures.

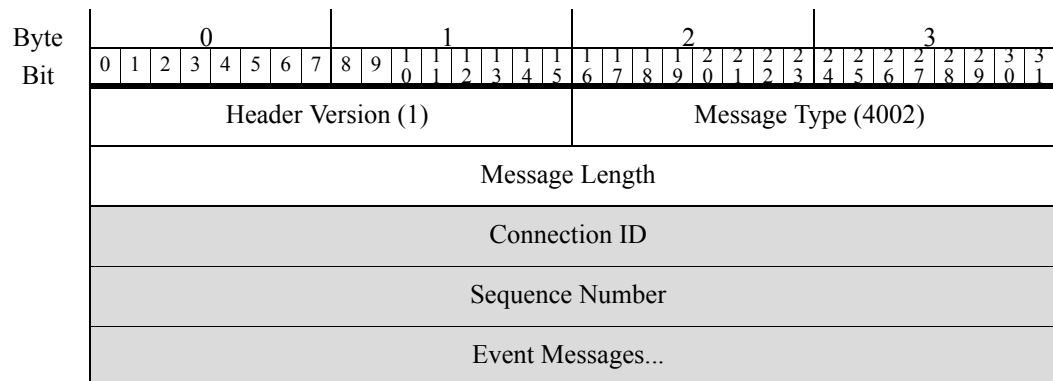

The fields of a message bundle message are:

Table 2-24 Message Bundle Message Fields

| Field          | Data Type | Description   |
|----------------|-----------|---|
| Header Version | uint16    | Always 1.   |
| Message Type   | uint16    | Always 4002.  |
| Message Length | uint32    | Length of the content of the message after the message header. Does not include the bytes in the bundle's Header Version, Message Type, and Message Length fields.<br><br>As the client loads a message from the bundle, it can subtract the message's total length (including header) from the length in this field. As long as the remainder is positive, there are more messages to process. |
| Connection ID  | uint32    | A unique identifier for the connection with the server.   |

Table 2-24 Message Bundle Message Fields (continued)

| Field             | Data Type | Description  |
|-------------------|-----------|--|
| Sequence Number   | uint32    | Starts at 1 and increments by one for each bundle sent by the eStreamer server.  |
| Event Messages [] | array     | The events streamed by the server in the bundle. Each message has a full set of headers, including message version number (1), archive timestamp if requested, and so forth. |

## Understanding Metadata

The eStreamer server can provide metadata along with requested event records. To receive metadata, you must explicitly request it. See [Table 2-6 on page 2-12](#) for information on how to request a given version of metadata. The metadata provides context information for codes and numeric identifiers in the event records. For example, an intrusion event contains only the internal identifier of the detecting device, and the metadata provides the device's name.

## Metadata Transmission

If the request message specifies metadata, eStreamer sends the relevant metadata record before it sends any related event records.

eStreamer keeps track of the metadata it has sent to the client and does not resend the same metadata record. The client should cache each received metadata record. eStreamer does not keep a history of metadata transmissions from one session to the next, so when a new session starts and a request message specifies metadata, eStreamer restarts metadata streaming from scratch.



# Understanding Intrusion and Correlation Data Structures

The eStreamer service transmits a number of data record types to deliver requested events and metadata to the client. This chapter describes the structures of data records for the following types of event data:

- intrusion events data and event extra data generated by managed devices
- correlation (compliance) events generated by the Defense Center
- metadata records

The following section in this chapter define the event message structures:

- [Intrusion Event and Metadata Record Types, page 3-1.](#)

For a general overview of eStreamer’s message format for transmitting data records, see [Event Data Message Format, page 2-17.](#)

## Intrusion Event and Metadata Record Types

The table that follows lists all currently supported record types for intrusion events, intrusion event extra data, and metadata messages. The data for these record types is in fixed-length fields. By contrast, correlation event records contain one or more levels of nested data blocks with variable lengths. The table below provides a link to the chapter subsection that defines the associated data record structure.

For some record types, eStreamer supports more than one version. The table indicates the status of each version (current or legacy). A current record is the latest version. A legacy record has been superseded by a later version but can still be requested from eStreamer.

**Table 3-1** *Intrusion Event and General Metadata Record Types*

| Record Type | Block Type | Series | Description                    | Record Status | Data Format Described in...                                 |
|-------------|------------|--------|--------------------------------|---------------|---|
| 2           | N/A        | N/A    | Packet Data (Version 4.8.0.2+) | Current       | <a href="#">Packet Record 4.8.0.2+, page 3-4</a>            |
| 4           | N/A        | N/A    | Priority Metadata              | Current       | <a href="#">Priority Record, page 3-5</a>                   |
| 9           | 20         | 1      | Intrusion Impact Alert         | Legacy        | <a href="#">Intrusion Impact Alert Data, page B-29</a>      |
| 9           | 153        | 1      | Intrusion Impact Alert         | Current       | <a href="#">Intrusion Impact Alert Data 5.3+, page 3-12</a> |
| 62          | N/A        | N/A    | User Metadata                  | Current       | <a href="#">User Record, page 3-15</a>                      |

Table 3-1 Intrusion Event and General Metadata Record Types (continued)

| Record Type | Block Type | Series | Description   | Record Status | Data Format Described in...   |
|-------------|------------|--------|---|---------------|---|
| 66          | N/A        | N/A    | Rule Message Metadata (Version 4.6.1+)                | Current       | <a href="#">Rule Message Record for 4.6.1+, page 3-16</a>             |
| 67          | N/A        | N/A    | Classification Metadata (Version 4.6.1+)              | Current       | <a href="#">Classification Record for 4.6.1+, page 3-17</a>           |
| 69          | N/A        | N/A    | Correlation Policy Metadata (Version 4.6.1+)          | Current       | <a href="#">Correlation Policy Record, page 3-18</a>                  |
| 70          | N/A        | N/A    | Correlation Rule Metadata (Version 4.6.1+)            | Current       | <a href="#">Correlation Rule Record, page 3-20</a>                    |
| 104         | N/A        | N/A    | Intrusion Event (IPv4) Record 4.9 - 4.10.x            | Legacy        | earlier versions of the product                                       |
| 105         | N/A        | N/A    | Intrusion Event (IPv6) Record 4.9-4.10.x              | Legacy        | earlier versions of the product                                       |
| 110         | 4          | 2      | Intrusion Event Extra Data (Version 4.10.0+)          | Current       | <a href="#">Intrusion Event Extra Data Record, page 3-21</a>          |
| 111         | 5          | 2      | Intrusion Event Extra Data Metadata (Version 4.10.0+) | Current       | <a href="#">Intrusion Event Extra Data Metadata, page 3-23</a>        |
| 112         | 128        | 1      | Correlation Event for 5.1+                            | Current       | <a href="#">Correlation Event for 5.1+, page 3-36</a>                 |
| 115         | 14         | 2      | Security Zone Name Metadata                           | Current       | <a href="#">Security Zone Name Record, page 3-25</a>                  |
| 116         | 14         | 2      | Interface Name Metadata                               | Current       | <a href="#">Interface Name Record, page 3-26</a>                      |
| 117         | 14         | 2      | Access Control Policy Name Metadata                   | Current       | <a href="#">Access Control Policy Name Record, page 3-27</a>          |
| 118         | 15         | 2      | Intrusion Policy Name Metadata                        | Current       | <a href="#">Intrusion Policy Name Record, page 4-20</a>               |
| 119         | 15         | 2      | Access Control Rule ID Metadata                       | Current       | <a href="#">Access Control Rule ID Record Metadata, page 3-28</a>     |
| 120         | N/A        | N/A    | Access Control Rule Action Metadata                   | Current       | <a href="#">Access Control Rule Action Record Metadata, page 4-21</a> |
| 121         | N/A        | N/A    | URL Category Metadata                                 | Current       | <a href="#">URL Category Record Metadata, page 4-22</a>               |
| 122         | N/A        | N/A    | URL Reputation Metadata                               | Current       | <a href="#">URL Reputation Record Metadata, page 4-23</a>             |
| 123         | N/A        | N/A    | Managed Device Metadata                               | Current       | <a href="#">Managed Device Record Metadata, page 3-30</a>             |
| 125         | N/A        | 2      | Malware Event Record (Version 5.1.1+)                 | Current       | <a href="#">Malware Event Record 5.1.1+, page 3-30</a>                |
| 125         | 24         | 2      | Malware Event (Version 5.1.1+)                        | Current       | <a href="#">Malware Event Data Block 5.1.1.x, page B-36</a>           |
| 125         | 33         | 2      | Malware Event (Version 5.2.x)                         | Legacy        | <a href="#">Malware Event Data Block 5.2.x, page B-42</a>             |
| 125         | 35         | 2      | Malware Event (Version 5.3)                           | Legacy        | <a href="#">Malware Event Data Block 5.3, page B-48</a>               |
| 125         | 44         | 2      | Malware Event (Version 5.3.1+)                        | Current       | <a href="#">Malware Event Data Block 5.3.1+, page 3-64</a>            |



Table 3-1 Intrusion Event and General Metadata Record Types (continued)

| Record Type | Block Type | Series | Description   | Record Status | Data Format Described in...   |
|-------------|------------|--------|---|---------------|---|
| 127         | 14         | 2      | Collective Security Intelligence Cloud Name Metadata (Version 5.1+) | Current       | <a href="#">Collective Security Intelligence Cloud Name Metadata, page 3-31</a> |
| 128         | N/A        | N/A    | Malware Event Type Metadata (Version 5.1+)                          | Current       | <a href="#">Malware Event Type Metadata, page 3-33</a>                          |
| 129         | N/A        | N/A    | Malware Event Subtype Metadata (Version 5.1+)                       | Current       | <a href="#">Malware Event Subtype Metadata, page 3-34</a>                       |
| 130         | N/A        | N/A    | FireAMP Detector Type Metadata (Version 5.1+)                       | Current       | <a href="#">FireAMP Detector Type Metadata, page 3-34</a>                       |
| 131         | N/A        | N/A    | FireAMP File Type Metadata (Version 5.1+)                           | Current       | <a href="#">FireAMP File Type Metadata, page 3-35</a>                           |
| 160         | 150        | 1      | IOC State Data Block for 5.3+                                       | Current       | <a href="#">IOC State Data Block for 5.3+, page 4-25</a>                        |
| 161         | 39         | 2      | IOC Name Data Block for 5.3+  | Current       | <a href="#">IOC Name Data Block for 5.3+, page 4-27</a>                         |
| 207         | N/A        | N/A    | Intrusion Event (IPv4) Record 5.0.x - 5.1                           | Legacy        | <a href="#">Intrusion Event (IPv4) Record 5.0.x - 5.1, page B-2</a>             |
| 208         | N/A        | N/A    | Intrusion Event (IPv6) Record 5.0.x - 5.1                           | Legacy        | <a href="#">Intrusion Event (IPv6) Record 5.0.x - 5.1, page B-6</a>             |
| 260         | 19         | 2      | ICMP Type Data Data Block   | Current       | <a href="#">ICMP Type Data Block, page 3-53</a>                                 |
| 270         | 20         | 2      | ICMP Code Data Block  | Current       | <a href="#">ICMP Code Data Block, page 3-54</a>                                 |
| 400         | 34         | 2      | Intrusion Event Record 5.2.x  | Legacy        | <a href="#">Intrusion Event Record 5.2.x, page B-11</a>                         |
| 400         | 41         | 2      | Intrusion Event Record 5.3  | Legacy        | <a href="#">Intrusion Event Record 5.3, page B-17</a>                           |
| 400         | 42         | 2      | Intrusion Event Record 5.3.1+                                       | Current       | <a href="#">Intrusion Event Record 5.3.1+, page 3-6</a>                         |
| 500         | 32         | 2      | File Event (Version 5.2.x)  | Legacy        | <a href="#">File Event for 5.2.x, page B-112</a>                                |
| 500         | 38         | 2      | File Event (Version 5.3)  | Legacy        | <a href="#">File Event for 5.3, page B-116</a>                                  |
| 500         | 43         | 2      | File Event (Version 5.3.1+)   | Current       | <a href="#">File Event for 5.3.1+, page 3-57</a>                                |
| 502         | 32         | 2      | File Event (Version 5.2.x)  | Legacy        | <a href="#">File Event for 5.2.x, page B-112</a>                                |
| 502         | 38         | 2      | File Event (Version 5.3)  | Legacy        | <a href="#">File Event for 5.3, page B-116</a>                                  |
| 502         | 43         | 2      | File Event (Version 5.3.1+)   | Current       | <a href="#">File Event for 5.3.1+, page 3-57</a>                                |
| N/A         | 27         | 2      | File Event SHA Hash for 5.3+  | Current       | <a href="#">File Event SHA Hash for 5.3+, page 3-71</a>                         |
| 511         | 27         | 2      | Rule Documentation Data Block for 5.2+                              | Current       | <a href="#">Rule Documentation Data Block for 5.2+, page 3-73</a>               |
| 520         | 28         | 2      | Geolocation Data Block for 5.2+                                     | Current       | <a href="#">Geolocation Data Block for 5.2+, page 3-76</a>                      |

## Packet Record 4.8.0.2+

The eStreamer service transmits the packet data associated with an event in a Packet record, the format of which is shown below. Packet data is sent when the Packet flag—bit 0 in the Request Flags field of a request message—is set. See [Request Flags, page 2-11](#). If you enable bit 23, an extended event header is included in the record. Note that the Record Type field, which appears after the Message Length field, has a value of 2, indicating a packet record.

|      |   |   |   |   |   |   |   |   |   |   |    |    |    |    |    |    |                  |    |    |    |    |    |    |    |    |    |    |    |    |    |    |    |
|------|---|---|---|---|---|---|---|---|---|---|----|----|----|----|----|----|------------------|----|----|----|----|----|----|----|----|----|----|----|----|----|----|----|
| Byte | 0   |   |   |   |   |   |   |   | 1 |   |    |    |    |    |    |    | 2                |    |    |    |    |    |    |    | 3  |    |    |    |    |    |    |    |
| Bit  | 0   | 1 | 2 | 3 | 4 | 5 | 6 | 7 | 8 | 9 | 10 | 11 | 12 | 13 | 14 | 15 | 16               | 17 | 18 | 19 | 20 | 21 | 22 | 23 | 24 | 25 | 26 | 27 | 28 | 29 | 30 | 31 |
|      | Header Version (1)  |   |   |   |   |   |   |   |   |   |    |    |    |    |    |    | Message Type (4) |    |    |    |    |    |    |    |    |    |    |    |    |    |    |    |
|      | Message Length  |   |   |   |   |   |   |   |   |   |    |    |    |    |    |    |                  |    |    |    |    |    |    |    |    |    |    |    |    |    |    |    |
|      | Record Type (2)   |   |   |   |   |   |   |   |   |   |    |    |    |    |    |    |                  |    |    |    |    |    |    |    |    |    |    |    |    |    |    |    |
|      | Record Length   |   |   |   |   |   |   |   |   |   |    |    |    |    |    |    |                  |    |    |    |    |    |    |    |    |    |    |    |    |    |    |    |
|      | eStreamer Server Timestamp (in events, only if bit 23 is set) |   |   |   |   |   |   |   |   |   |    |    |    |    |    |    |                  |    |    |    |    |    |    |    |    |    |    |    |    |    |    |    |
|      | Reserved for Future Use (in events, only if bit 23 is set)    |   |   |   |   |   |   |   |   |   |    |    |    |    |    |    |                  |    |    |    |    |    |    |    |    |    |    |    |    |    |    |    |
|      | Device ID   |   |   |   |   |   |   |   |   |   |    |    |    |    |    |    |                  |    |    |    |    |    |    |    |    |    |    |    |    |    |    |    |
|      | Event ID  |   |   |   |   |   |   |   |   |   |    |    |    |    |    |    |                  |    |    |    |    |    |    |    |    |    |    |    |    |    |    |    |
|      | Event Second  |   |   |   |   |   |   |   |   |   |    |    |    |    |    |    |                  |    |    |    |    |    |    |    |    |    |    |    |    |    |    |    |
|      | Packet Second   |   |   |   |   |   |   |   |   |   |    |    |    |    |    |    |                  |    |    |    |    |    |    |    |    |    |    |    |    |    |    |    |
|      | Packet Microsecond  |   |   |   |   |   |   |   |   |   |    |    |    |    |    |    |                  |    |    |    |    |    |    |    |    |    |    |    |    |    |    |    |
|      | Link Type   |   |   |   |   |   |   |   |   |   |    |    |    |    |    |    |                  |    |    |    |    |    |    |    |    |    |    |    |    |    |    |    |
|      | Packet Length   |   |   |   |   |   |   |   |   |   |    |    |    |    |    |    |                  |    |    |    |    |    |    |    |    |    |    |    |    |    |    |    |
|      | Packet Data...  |   |   |   |   |   |   |   |   |   |    |    |    |    |    |    |                  |    |    |    |    |    |    |    |    |    |    |    |    |    |    |    |

The following table describes the fields in the Packet record.

**Table 3-2** Packet Record Fields

| Field         | Data Type | Description   |
|---------------|-----------|---|
| Device ID     | uint32    | The device identification number. You can obtain device names that correlate to them by requesting Version 3 or 4 metadata. See <a href="#">Managed Device Record Metadata, page 3-30</a> for more information. |
| Event ID      | uint32    | The event identification number.  |
| Event Second  | uint32    | The second (from 01/01/1970) that the event occurred.   |
| Packet Second | uint32    | The second (from 01/01/1970) that the packet was captured.  |

Table 3-2 Packet Record Fields (continued)

| Field              | Data Type | Description   |
|--------------------|-----------|---|
| Packet Microsecond | uint32    | Microsecond (one millionth of a second) increment that the packet was captured.         |
| Link Type          | uint32    | Link layer type. Currently, the value will always be 1 (signifying the Ethernet layer). |
| Packet Length      | uint32    | Number of bytes included in the packet data.  |
| Packet Data        | variable  | Actual captured packet data (header and payload).                                       |

## Priority Record

The eStreamer service transmits the priority associated with an event in a Priority record, the format of which is shown below. (Priority information is sent when one of the metadata flags—bits 1, 14, 15, or 20 in the Request Flags field of a request message—is set. See [Request Flags, page 2-11.](#)) Note that the Record Type field, which appears after the Message Length field, has a value of 4, indicating a Priority record.

| Byte | 0                  |   |   |   | 1 |   |   |   | 2                |   |    |    | 3  |    |    |    |    |    |    |    |    |    |    |    |    |    |    |    |    |    |    |    |
|------|--------------------|---|---|---|---|---|---|---|------------------|---|----|----|----|----|----|----|----|----|----|----|----|----|----|----|----|----|----|----|----|----|----|----|
| Bit  | 0                  | 1 | 2 | 3 | 4 | 5 | 6 | 7 | 8                | 9 | 10 | 11 | 12 | 13 | 14 | 15 | 16 | 17 | 18 | 19 | 20 | 21 | 22 | 23 | 24 | 25 | 26 | 27 | 28 | 29 | 30 | 31 |
|      | Header Version (1) |   |   |   |   |   |   |   | Message Type (4) |   |    |    |    |    |    |    |    |    |    |    |    |    |    |    |    |    |    |    |    |    |    |    |
|      | Message Length     |   |   |   |   |   |   |   |                  |   |    |    |    |    |    |    |    |    |    |    |    |    |    |    |    |    |    |    |    |    |    |    |
|      | Record Type (4)    |   |   |   |   |   |   |   |                  |   |    |    |    |    |    |    |    |    |    |    |    |    |    |    |    |    |    |    |    |    |    |    |
|      | Record Length      |   |   |   |   |   |   |   |                  |   |    |    |    |    |    |    |    |    |    |    |    |    |    |    |    |    |    |    |    |    |    |    |
|      | Priority ID        |   |   |   |   |   |   |   |                  |   |    |    |    |    |    |    |    |    |    |    |    |    |    |    |    |    |    |    |    |    |    |    |
|      | Name Length        |   |   |   |   |   |   |   | Priority Name... |   |    |    |    |    |    |    |    |    |    |    |    |    |    |    |    |    |    |    |    |    |    |    |

The following table describes each priority-specific field.

Table 3-3 Priority Record Fields

| Field         | Data Type | Description  |
|---------------|-----------|--|
| Priority ID   | uint32    | Indicates the priority identification number.  |
| Name Length   | uint16    | Number of bytes included in the priority name.                                       |
| Priority Name | variable  | Priority name that corresponds with the priority ID (1 - high, 2 - medium, 3 - low). |

## Intrusion Event Record 5.3.1+

The fields in the intrusion event record are shaded in the following graphic. The record type is 400 and the block type is 42 in the series 2 set of data blocks.

You can request 5.3.1+ intrusion events from eStreamer only by extended request, for which you request event type code 12 and version code 7 in the Stream Request message (see [Submitting Extended Requests, page 2-4](#) for information about submitting extended requests).

For version 5.3.1+ intrusion events, the event ID, the managed device ID, and the event second form a unique identifier. The connection second, connection instance, and connection counter together form a unique identifier for the connection event associated with the intrusion event.

| Byte | 0   |   |   |   | 1 |   |   |   | 2                |   |    |    | 3  |    |    |    |    |    |    |    |    |    |    |    |    |    |    |    |    |    |    |    |
|------|---|---|---|---|---|---|---|---|------------------|---|----|----|----|----|----|----|----|----|----|----|----|----|----|----|----|----|----|----|----|----|----|----|
| Bit  | 0   | 1 | 2 | 3 | 4 | 5 | 6 | 7 | 8                | 9 | 10 | 11 | 12 | 13 | 14 | 15 | 16 | 17 | 18 | 19 | 20 | 21 | 22 | 23 | 24 | 25 | 26 | 27 | 28 | 29 | 30 | 31 |
|      | Header Version (1)  |   |   |   |   |   |   |   | Message Type (4) |   |    |    |    |    |    |    |    |    |    |    |    |    |    |    |    |    |    |    |    |    |    |    |
|      | Message Length  |   |   |   |   |   |   |   |                  |   |    |    |    |    |    |    |    |    |    |    |    |    |    |    |    |    |    |    |    |    |    |    |
|      | Record Type (400)   |   |   |   |   |   |   |   |                  |   |    |    |    |    |    |    |    |    |    |    |    |    |    |    |    |    |    |    |    |    |    |    |
|      | Record Length   |   |   |   |   |   |   |   |                  |   |    |    |    |    |    |    |    |    |    |    |    |    |    |    |    |    |    |    |    |    |    |    |
|      | eStreamer Server Timestamp (in events, only if bit 23 is set) |   |   |   |   |   |   |   |                  |   |    |    |    |    |    |    |    |    |    |    |    |    |    |    |    |    |    |    |    |    |    |    |
|      | Reserved for Future Use (in events, only if bit 23 is set)    |   |   |   |   |   |   |   |                  |   |    |    |    |    |    |    |    |    |    |    |    |    |    |    |    |    |    |    |    |    |    |    |
|      | Block Type (42)   |   |   |   |   |   |   |   |                  |   |    |    |    |    |    |    |    |    |    |    |    |    |    |    |    |    |    |    |    |    |    |    |
|      | Block Length  |   |   |   |   |   |   |   |                  |   |    |    |    |    |    |    |    |    |    |    |    |    |    |    |    |    |    |    |    |    |    |    |
|      | Device ID   |   |   |   |   |   |   |   |                  |   |    |    |    |    |    |    |    |    |    |    |    |    |    |    |    |    |    |    |    |    |    |    |
|      | Event ID  |   |   |   |   |   |   |   |                  |   |    |    |    |    |    |    |    |    |    |    |    |    |    |    |    |    |    |    |    |    |    |    |
|      | Event Second  |   |   |   |   |   |   |   |                  |   |    |    |    |    |    |    |    |    |    |    |    |    |    |    |    |    |    |    |    |    |    |    |
|      | Event Microsecond   |   |   |   |   |   |   |   |                  |   |    |    |    |    |    |    |    |    |    |    |    |    |    |    |    |    |    |    |    |    |    |    |
|      | Rule ID (Signature ID)  |   |   |   |   |   |   |   |                  |   |    |    |    |    |    |    |    |    |    |    |    |    |    |    |    |    |    |    |    |    |    |    |
|      | Generator ID  |   |   |   |   |   |   |   |                  |   |    |    |    |    |    |    |    |    |    |    |    |    |    |    |    |    |    |    |    |    |    |    |
|      | Rule Revision   |   |   |   |   |   |   |   |                  |   |    |    |    |    |    |    |    |    |    |    |    |    |    |    |    |    |    |    |    |    |    |    |
|      | Classification ID   |   |   |   |   |   |   |   |                  |   |    |    |    |    |    |    |    |    |    |    |    |    |    |    |    |    |    |    |    |    |    |    |
|      | Priority ID   |   |   |   |   |   |   |   |                  |   |    |    |    |    |    |    |    |    |    |    |    |    |    |    |    |    |    |    |    |    |    |    |

|                                       |   |   |   |   |   |   |   |              |   |   |    |    |    |    |    |                               |    |    |    |    |    |    |    |         |    |    |    |    |    |    |    |    |
|---------------------------------------|---|---|---|---|---|---|---|--------------|---|---|----|----|----|----|----|-------------------------------|----|----|----|----|----|----|----|---------|----|----|----|----|----|----|----|----|
| Byte                                  | 0 |   |   |   |   |   |   |              | 1 |   |    |    |    |    |    |                               | 2  |    |    |    |    |    |    |         | 3  |    |    |    |    |    |    |    |
| Bit                                   | 0 | 1 | 2 | 3 | 4 | 5 | 6 | 7            | 8 | 9 | 10 | 11 | 12 | 13 | 14 | 15                            | 16 | 17 | 18 | 19 | 20 | 21 | 22 | 23      | 24 | 25 | 26 | 27 | 28 | 29 | 30 | 31 |
| Source IP Address                     |   |   |   |   |   |   |   |              |   |   |    |    |    |    |    |                               |    |    |    |    |    |    |    |         |    |    |    |    |    |    |    |    |
| Source IP Address, continued          |   |   |   |   |   |   |   |              |   |   |    |    |    |    |    |                               |    |    |    |    |    |    |    |         |    |    |    |    |    |    |    |    |
| Source IP Address, continued          |   |   |   |   |   |   |   |              |   |   |    |    |    |    |    |                               |    |    |    |    |    |    |    |         |    |    |    |    |    |    |    |    |
| Source IP Address, continued          |   |   |   |   |   |   |   |              |   |   |    |    |    |    |    |                               |    |    |    |    |    |    |    |         |    |    |    |    |    |    |    |    |
| Destination IP Address                |   |   |   |   |   |   |   |              |   |   |    |    |    |    |    |                               |    |    |    |    |    |    |    |         |    |    |    |    |    |    |    |    |
| Destination IP Address, continued     |   |   |   |   |   |   |   |              |   |   |    |    |    |    |    |                               |    |    |    |    |    |    |    |         |    |    |    |    |    |    |    |    |
| Destination IP Address, continued     |   |   |   |   |   |   |   |              |   |   |    |    |    |    |    |                               |    |    |    |    |    |    |    |         |    |    |    |    |    |    |    |    |
| Destination IP Address, continued     |   |   |   |   |   |   |   |              |   |   |    |    |    |    |    |                               |    |    |    |    |    |    |    |         |    |    |    |    |    |    |    |    |
| Source Port or ICMP Type              |   |   |   |   |   |   |   |              |   |   |    |    |    |    |    | Destination Port or ICMP Code |    |    |    |    |    |    |    |         |    |    |    |    |    |    |    |    |
| IP Protocol ID                        |   |   |   |   |   |   |   | Impact Flags |   |   |    |    |    |    |    | Impact                        |    |    |    |    |    |    |    | Blocked |    |    |    |    |    |    |    |    |
| MPLS Label                            |   |   |   |   |   |   |   |              |   |   |    |    |    |    |    |                               |    |    |    |    |    |    |    |         |    |    |    |    |    |    |    |    |
| VLAN ID                               |   |   |   |   |   |   |   |              |   |   |    |    |    |    |    | Pad                           |    |    |    |    |    |    |    |         |    |    |    |    |    |    |    |    |
| Policy UUID                           |   |   |   |   |   |   |   |              |   |   |    |    |    |    |    |                               |    |    |    |    |    |    |    |         |    |    |    |    |    |    |    |    |
| Policy UUID, continued                |   |   |   |   |   |   |   |              |   |   |    |    |    |    |    |                               |    |    |    |    |    |    |    |         |    |    |    |    |    |    |    |    |
| Policy UUID, continued                |   |   |   |   |   |   |   |              |   |   |    |    |    |    |    |                               |    |    |    |    |    |    |    |         |    |    |    |    |    |    |    |    |
| Policy UUID, continued                |   |   |   |   |   |   |   |              |   |   |    |    |    |    |    |                               |    |    |    |    |    |    |    |         |    |    |    |    |    |    |    |    |
| User ID                               |   |   |   |   |   |   |   |              |   |   |    |    |    |    |    |                               |    |    |    |    |    |    |    |         |    |    |    |    |    |    |    |    |
| Web Application ID                    |   |   |   |   |   |   |   |              |   |   |    |    |    |    |    |                               |    |    |    |    |    |    |    |         |    |    |    |    |    |    |    |    |
| Client Application ID                 |   |   |   |   |   |   |   |              |   |   |    |    |    |    |    |                               |    |    |    |    |    |    |    |         |    |    |    |    |    |    |    |    |
| Application Protocol ID               |   |   |   |   |   |   |   |              |   |   |    |    |    |    |    |                               |    |    |    |    |    |    |    |         |    |    |    |    |    |    |    |    |
| Access Control Rule ID                |   |   |   |   |   |   |   |              |   |   |    |    |    |    |    |                               |    |    |    |    |    |    |    |         |    |    |    |    |    |    |    |    |
| Access Control Policy UUID            |   |   |   |   |   |   |   |              |   |   |    |    |    |    |    |                               |    |    |    |    |    |    |    |         |    |    |    |    |    |    |    |    |
| Access Control Policy UUID, continued |   |   |   |   |   |   |   |              |   |   |    |    |    |    |    |                               |    |    |    |    |    |    |    |         |    |    |    |    |    |    |    |    |
| Access Control Policy UUID, continued |   |   |   |   |   |   |   |              |   |   |    |    |    |    |    |                               |    |    |    |    |    |    |    |         |    |    |    |    |    |    |    |    |
| Access Control Policy UUID, continued |   |   |   |   |   |   |   |              |   |   |    |    |    |    |    |                               |    |    |    |    |    |    |    |         |    |    |    |    |    |    |    |    |
| Interface Ingress UUID                |   |   |   |   |   |   |   |              |   |   |    |    |    |    |    |                               |    |    |    |    |    |    |    |         |    |    |    |    |    |    |    |    |

| Byte                                  | 0 |   |   |   |   |   |   |   | 1 |   |    |    |    |    |    |                     | 2  |    |    |    |    |    |    |    | 3  |    |    |    |    |    |    |    |
|---------------------------------------|---|---|---|---|---|---|---|---|---|---|----|----|----|----|----|---------------------|----|----|----|----|----|----|----|----|----|----|----|----|----|----|----|----|
| Bit                                   | 0 | 1 | 2 | 3 | 4 | 5 | 6 | 7 | 8 | 9 | 10 | 11 | 12 | 13 | 14 | 15                  | 16 | 17 | 18 | 19 | 20 | 21 | 22 | 23 | 24 | 25 | 26 | 27 | 28 | 29 | 30 | 31 |
| Interface Ingress UUID, continued     |   |   |   |   |   |   |   |   |   |   |    |    |    |    |    |                     |    |    |    |    |    |    |    |    |    |    |    |    |    |    |    |    |
| Interface Ingress UUID, continued     |   |   |   |   |   |   |   |   |   |   |    |    |    |    |    |                     |    |    |    |    |    |    |    |    |    |    |    |    |    |    |    |    |
| Interface Ingress UUID, continued     |   |   |   |   |   |   |   |   |   |   |    |    |    |    |    |                     |    |    |    |    |    |    |    |    |    |    |    |    |    |    |    |    |
| Interface Egress UUID                 |   |   |   |   |   |   |   |   |   |   |    |    |    |    |    |                     |    |    |    |    |    |    |    |    |    |    |    |    |    |    |    |    |
| Interface Egress UUID, continued      |   |   |   |   |   |   |   |   |   |   |    |    |    |    |    |                     |    |    |    |    |    |    |    |    |    |    |    |    |    |    |    |    |
| Interface Egress UUID, continued      |   |   |   |   |   |   |   |   |   |   |    |    |    |    |    |                     |    |    |    |    |    |    |    |    |    |    |    |    |    |    |    |    |
| Interface Egress UUID, continued      |   |   |   |   |   |   |   |   |   |   |    |    |    |    |    |                     |    |    |    |    |    |    |    |    |    |    |    |    |    |    |    |    |
| Security Zone Ingress UUID            |   |   |   |   |   |   |   |   |   |   |    |    |    |    |    |                     |    |    |    |    |    |    |    |    |    |    |    |    |    |    |    |    |
| Security Zone Ingress UUID, continued |   |   |   |   |   |   |   |   |   |   |    |    |    |    |    |                     |    |    |    |    |    |    |    |    |    |    |    |    |    |    |    |    |
| Security Zone Ingress UUID, continued |   |   |   |   |   |   |   |   |   |   |    |    |    |    |    |                     |    |    |    |    |    |    |    |    |    |    |    |    |    |    |    |    |
| Security Zone Ingress UUID, continued |   |   |   |   |   |   |   |   |   |   |    |    |    |    |    |                     |    |    |    |    |    |    |    |    |    |    |    |    |    |    |    |    |
| Security Zone Egress UUID             |   |   |   |   |   |   |   |   |   |   |    |    |    |    |    |                     |    |    |    |    |    |    |    |    |    |    |    |    |    |    |    |    |
| Security Zone Egress UUID, continued  |   |   |   |   |   |   |   |   |   |   |    |    |    |    |    |                     |    |    |    |    |    |    |    |    |    |    |    |    |    |    |    |    |
| Security Zone Egress UUID, continued  |   |   |   |   |   |   |   |   |   |   |    |    |    |    |    |                     |    |    |    |    |    |    |    |    |    |    |    |    |    |    |    |    |
| Security Zone Egress UUID, continued  |   |   |   |   |   |   |   |   |   |   |    |    |    |    |    |                     |    |    |    |    |    |    |    |    |    |    |    |    |    |    |    |    |
| Connection Timestamp                  |   |   |   |   |   |   |   |   |   |   |    |    |    |    |    |                     |    |    |    |    |    |    |    |    |    |    |    |    |    |    |    |    |
| Connection Instance ID                |   |   |   |   |   |   |   |   |   |   |    |    |    |    |    | Connection Counter  |    |    |    |    |    |    |    |    |    |    |    |    |    |    |    |    |
| Source Country                        |   |   |   |   |   |   |   |   |   |   |    |    |    |    |    | Destination Country |    |    |    |    |    |    |    |    |    |    |    |    |    |    |    |    |
| IOC Number                            |   |   |   |   |   |   |   |   |   |   |    |    |    |    |    | Security Context    |    |    |    |    |    |    |    |    |    |    |    |    |    |    |    |    |
| Security Context, continued           |   |   |   |   |   |   |   |   |   |   |    |    |    |    |    |                     |    |    |    |    |    |    |    |    |    |    |    |    |    |    |    |    |
| Security Context, continued           |   |   |   |   |   |   |   |   |   |   |    |    |    |    |    |                     |    |    |    |    |    |    |    |    |    |    |    |    |    |    |    |    |
| Security Context, continued           |   |   |   |   |   |   |   |   |   |   |    |    |    |    |    |                     |    |    |    |    |    |    |    |    |    |    |    |    |    |    |    |    |
| Security Context, continued           |   |   |   |   |   |   |   |   |   |   |    |    |    |    |    |                     |    |    |    |    |    |    |    |    |    |    |    |    |    |    |    |    |

The following table describes each intrusion event record data field.

Table 3-4 Intrusion Event Record 5.3.1+ Fields

| Field                         | Data Type | Description   |
|-------------------------------|-----------|---|
| Block Type                    | uint32    | Initiates an Intrusion Event data block. This value is always 42.   |
| Block Length                  | uint32    | Total number of bytes in the Intrusion Event data block, including eight bytes for the Intrusion Event block type and length fields, plus the number of bytes of data that follows.   |
| Device ID                     | uint32    | Contains the identification number of the detecting managed device. You can obtain the managed device name by requesting Version 3 or 4 metadata. See <a href="#">Managed Device Record Metadata, page 3-30</a> for more information. |
| Event ID                      | uint32    | Event identification number.  |
| Event Second                  | uint32    | UNIX timestamp (seconds since 01/01/1970) of the event's detection.   |
| Event Microsecond             | uint32    | Microsecond (one millionth of a second) increment of the timestamp of the event's detection.  |
| Rule ID (Signature ID)        | uint32    | Rule identification number that corresponds with the event.   |
| Generator ID                  | uint32    | Identification number of the FireSIGHT System preprocessor that generated the event.  |
| Rule Revision                 | uint32    | Rule revision number.   |
| Classification ID             | uint32    | Identification number of the event classification message.  |
| Priority ID                   | uint32    | Identification number of the priority associated with the event.  |
| Source IP Address             | uint8[16] | Source IPv4 or IPv6 address used in the event.  |
| Destination IP Address        | uint8[16] | Destination IPv4 or IPv6 address used in the event.   |
| Source Port or ICMP Type      | uint16    | The source port number if the event protocol type is TCP or UDP, or the ICMP type if the event is caused by ICMP traffic.   |
| Destination Port or ICMP Code | uint16    | The destination port number if the event protocol type is TCP or UDP, or the ICMP code if the event is caused by ICMP traffic.  |
| IP Protocol Number            | uint8     | IANA-specified protocol number. For example: <ul style="list-style-type: none"> <li>• 0 - IP</li> <li>• 1 - ICMP</li> <li>• 6 - TCP</li> <li>• 17 - UDP</li> </ul>  |

Table 3-4 Intrusion Event Record 5.3.1+ Fields (continued)

| Field        | Data Type | Description   |
|--------------|-----------|---|
| Impact Flags | bits[8]   | <p>Impact flag value of the event. The low-order eight bits indicate the impact level. Values are:</p> <ul style="list-style-type: none"> <li>0x01 (bit 0) - Source or destination host is in a network monitored by the system.</li> <li>0x02 (bit 1) - Source or destination host exists in the network map.</li> <li>0x04 (bit 2) - Source or destination host is running a server on the port in the event (if TCP or UDP) or uses the IP protocol.</li> <li>0x08 (bit 3) - There is a vulnerability mapped to the operating system of the source or destination host in the event.</li> <li>0x10 (bit 4) - There is a vulnerability mapped to the server detected in the event.</li> <li>0x20 (bit 5) - The event caused the managed device to drop the session (used only when the device is running in inline, switched, or routed deployment). Corresponds to blocked status in the FireSIGHT System web interface.</li> <li>0x40 (bit 6) - The rule that generated this event contains rule metadata setting the impact flag to red. The source or destination host is potentially compromised by a virus, trojan, or other piece of malicious software.</li> <li>0x80 (bit 7) - There is a vulnerability mapped to the client detected in the event. (version 5.0+ only)</li> </ul> <p>The following impact level values map to specific priorities on the Defense Center. An x indicates the value can be 0 or 1:</p> <ul style="list-style-type: none"> <li>gray (0, unknown): 00X00000</li> <li>red (1, vulnerable): XXXX1XXX, XXX1XXXX, X1XXXXXX, 1XXXXXXX (version 5.0+ only)</li> <li>orange (2, potentially vulnerable): 00X0011X</li> <li>yellow (3, currently not vulnerable): 00X0001X</li> <li>blue (4, unknown target): 00X00001</li> </ul> |
| Impact       | uint8     | <p>Impact flag value of the event. Values are:</p> <ul style="list-style-type: none"> <li>1 - Red (vulnerable)</li> <li>2 - Orange (potentially vulnerable)</li> <li>3 - Yellow (currently not vulnerable)</li> <li>4 - Blue (unknown target)</li> <li>5 - Gray (unknown impact)</li> </ul>   |
| Blocked      | uint8     | <p>Value indicating whether the event was blocked:</p> <ul style="list-style-type: none"> <li>0 - not blocked</li> <li>1 - blocked</li> <li>2 - would be blocked (but not permitted by configuration)</li> </ul>  |



Table 3-4 Intrusion Event Record 5.3.1+ Fields (continued)

| Field                      | Data Type | Description  |
|----------------------------|-----------|--|
| MPLS Label                 | uint32    | MPLS label.  |
| VLAN ID                    | uint16    | Indicates the ID of the VLAN where the packet originated.  |
| Pad                        | uint16    | Reserved for future use.   |
| Policy UUID                | uint8[16] | A policy ID number that acts as a unique identifier for the intrusion policy.  |
| User ID                    | uint32    | The internal identification number for the user, if applicable.  |
| Web Application ID         | uint32    | The internal identification number for the web application, if applicable.   |
| Client Application ID      | uint32    | The internal identification number for the client application, if applicable.  |
| Application Protocol ID    | uint32    | The internal identification number for the application protocol, if applicable.  |
| Access Control Rule ID     | uint32    | A rule ID number that acts as a unique identifier for the access control rule.   |
| Access Control Policy UUID | uint8[16] | A policy ID number that acts as a unique identifier for the access control policy.   |
| Ingress Interface UUID     | uint8[16] | An interface ID number that acts as a unique identifier for the ingress interface.   |
| Egress Interface UUID      | uint8[16] | An interface ID number that acts as a unique identifier for the egress interface.  |
| Ingress Security Zone UUID | uint8[16] | A zone ID number that acts as a unique identifier for the ingress security zone.   |
| Egress Security Zone UUID  | uint8[16] | A zone ID number that acts as a unique identifier for the egress security zone.  |
| Connection Timestamp       | uint32    | UNIX timestamp (seconds since 01/01/1970) of the connection event associated with the intrusion event.   |
| Connection Instance ID     | uint16    | Numerical ID of the Snort instance on the managed device that generated the connection event.  |
| Connection Counter         | uint16    | Value used to distinguish between connection events that happen during the same second.  |
| Source Country             | uint16    | Code for the country of the source host.   |
| Destination Country        | uint16    | Code for the country of the destination host.  |
| IOC Number                 | uint16    | ID number of the compromise associated with this event.  |
| Security Context           | uint8(16) | ID number for the security context (virtual firewall) that the traffic passed through. Note that the system only populates this field for ASA FirePOWER devices in multi-context mode. |

## Intrusion Impact Alert Data 5.3+

The Intrusion Impact Alert 5.3+ event contains information about impact events. It is transmitted when an intrusion event is compared to the system network map data and the impact is determined. It uses the standard record header with a record type of 9, followed by an Intrusion Impact Alert data block with a series 1 data block type of 153 in the series 1 group of blocks. (The Impact Alert data block is a type of series 1 data block. For more information about series 1 data blocks, see [Understanding Discovery \(Series 1\) Blocks, page 4-55.](#))

You can request that eStreamer only transmit intrusion impact events by setting bit 5 in the Flags field of the request message. See [Event Stream Request Message Format, page 2-10](#) for more information about request messages. Version 1 of these alerts only handles IPv4. Version 2, introduced in 5.3, handles IPv6 events in addition to IPv4.

| Byte | 0   |   |   |   |   |   |   |   | 1 |   |    |    |    |    |    |    | 2                |    |    |    |    |    |    |    | 3  |    |    |    |    |    |    |    |
|------|---|---|---|---|---|---|---|---|---|---|----|----|----|----|----|----|------------------|----|----|----|----|----|----|----|----|----|----|----|----|----|----|----|
| Bit  | 0   | 1 | 2 | 3 | 4 | 5 | 6 | 7 | 8 | 9 | 10 | 11 | 12 | 13 | 14 | 15 | 16               | 17 | 18 | 19 | 20 | 21 | 22 | 23 | 24 | 25 | 26 | 27 | 28 | 29 | 30 | 31 |
|      | Header Version (1)  |   |   |   |   |   |   |   |   |   |    |    |    |    |    |    | Message Type (4) |    |    |    |    |    |    |    |    |    |    |    |    |    |    |    |
|      | Message Length  |   |   |   |   |   |   |   |   |   |    |    |    |    |    |    |                  |    |    |    |    |    |    |    |    |    |    |    |    |    |    |    |
|      | Record Type (9)   |   |   |   |   |   |   |   |   |   |    |    |    |    |    |    |                  |    |    |    |    |    |    |    |    |    |    |    |    |    |    |    |
|      | eStreamer Server Timestamp (in events, only if bit 23 is set) |   |   |   |   |   |   |   |   |   |    |    |    |    |    |    |                  |    |    |    |    |    |    |    |    |    |    |    |    |    |    |    |
|      | Reserved for Future Use (in events, only if bit 23 is set)    |   |   |   |   |   |   |   |   |   |    |    |    |    |    |    |                  |    |    |    |    |    |    |    |    |    |    |    |    |    |    |    |
|      | Intrusion Impact Alert Block Length                           |   |   |   |   |   |   |   |   |   |    |    |    |    |    |    |                  |    |    |    |    |    |    |    |    |    |    |    |    |    |    |    |
|      | Event ID  |   |   |   |   |   |   |   |   |   |    |    |    |    |    |    |                  |    |    |    |    |    |    |    |    |    |    |    |    |    |    |    |
|      | Device ID   |   |   |   |   |   |   |   |   |   |    |    |    |    |    |    |                  |    |    |    |    |    |    |    |    |    |    |    |    |    |    |    |
|      | Event Second  |   |   |   |   |   |   |   |   |   |    |    |    |    |    |    |                  |    |    |    |    |    |    |    |    |    |    |    |    |    |    |    |
|      | Impact  |   |   |   |   |   |   |   |   |   |    |    |    |    |    |    |                  |    |    |    |    |    |    |    |    |    |    |    |    |    |    |    |
|      | Source IP Address   |   |   |   |   |   |   |   |   |   |    |    |    |    |    |    |                  |    |    |    |    |    |    |    |    |    |    |    |    |    |    |    |
|      | Source IP Address, continued                                  |   |   |   |   |   |   |   |   |   |    |    |    |    |    |    |                  |    |    |    |    |    |    |    |    |    |    |    |    |    |    |    |
|      | Source IP Address, continued                                  |   |   |   |   |   |   |   |   |   |    |    |    |    |    |    |                  |    |    |    |    |    |    |    |    |    |    |    |    |    |    |    |
|      | Source IP Address, continued                                  |   |   |   |   |   |   |   |   |   |    |    |    |    |    |    |                  |    |    |    |    |    |    |    |    |    |    |    |    |    |    |    |
|      | Destination IP Address  |   |   |   |   |   |   |   |   |   |    |    |    |    |    |    |                  |    |    |    |    |    |    |    |    |    |    |    |    |    |    |    |
|      | Destination IP Address, continued                             |   |   |   |   |   |   |   |   |   |    |    |    |    |    |    |                  |    |    |    |    |    |    |    |    |    |    |    |    |    |    |    |
|      | Destination IP Address, continued                             |   |   |   |   |   |   |   |   |   |    |    |    |    |    |    |                  |    |    |    |    |    |    |    |    |    |    |    |    |    |    |    |
|      | Destination IP Address, continued                             |   |   |   |   |   |   |   |   |   |    |    |    |    |    |    |                  |    |    |    |    |    |    |    |    |    |    |    |    |    |    |    |

|                    |                       |   |   |   |   |   |   |   |   |   |    |    |    |    |    |    |    |    |    |    |    |    |    |    |    |    |    |    |    |    |    |    |
|--------------------|-----------------------|---|---|---|---|---|---|---|---|---|----|----|----|----|----|----|----|----|----|----|----|----|----|----|----|----|----|----|----|----|----|----|
| Byte               | 0                     |   |   |   |   |   |   |   | 1 |   |    |    |    |    |    |    | 2  |    |    |    |    |    |    |    | 3  |    |    |    |    |    |    |    |
| Bit                | 0                     | 1 | 2 | 3 | 4 | 5 | 6 | 7 | 8 | 9 | 10 | 11 | 12 | 13 | 14 | 15 | 16 | 17 | 18 | 19 | 20 | 21 | 22 | 23 | 24 | 25 | 26 | 27 | 28 | 29 | 30 | 31 |
| Impact Description | String Block Type (0) |   |   |   |   |   |   |   |   |   |    |    |    |    |    |    |    |    |    |    |    |    |    |    |    |    |    |    |    |    |    |    |
|                    | String Block Length   |   |   |   |   |   |   |   |   |   |    |    |    |    |    |    |    |    |    |    |    |    |    |    |    |    |    |    |    |    |    |    |
|                    | Description...        |   |   |   |   |   |   |   |   |   |    |    |    |    |    |    |    |    |    |    |    |    |    |    |    |    |    |    |    |    |    |    |

The following table describes each data field in an impact event.

**Table 3-5** Impact Event Data Fields

| Field                               | Data Type | Description   |
|-------------------------------------|-----------|---|
| Intrusion Impact Alert Block Type   | uint32    | Indicates that an intrusion impact alert data block follows. This field will always have a value of 20. See <a href="#">Intrusion Event and Metadata Record Types, page 3-1</a> . |
| Intrusion Impact Alert Block Length | uint32    | Indicates the length of the intrusion impact alert data block, including all data that follows and 8 bytes for the intrusion impact alert block type and length.                  |
| Event ID                            | uint32    | Indicates the event identification number.  |
| Device ID                           | uint32    | Indicates the managed device identification number.   |
| Event Second                        | uint32    | Indicates the second (from 01/01/1970) that the event was detected.   |

Table 3-5 Impact Event Data Fields (continued)

| Field                  | Data Type | Description   |
|------------------------|-----------|---|
| Impact                 | bits[8]   | <p>Impact flag value of the event. The low-order eight bits indicate the impact level. Values are:</p> <ul style="list-style-type: none"> <li>0x01 (bit 0) - Source or destination host is in a network monitored by the system.</li> <li>0x02 (bit 1) - Source or destination host exists in the network map.</li> <li>0x04 (bit 2) - Source or destination host is running a server on the port in the event (if TCP or UDP) or uses the IP protocol.</li> <li>0x08 (bit 3) - There is a vulnerability mapped to the operating system of the source or destination host in the event.</li> <li>0x10 (bit 4) - There is a vulnerability mapped to the server detected in the event.</li> <li>0x20 (bit 5) - The event caused the managed device to drop the session (used only when the device is running in inline, switched, or routed deployment). Corresponds to blocked status in the FireSIGHT System web interface.</li> <li>0x40 (bit 6) - The rule that generated this event contains rule metadata setting the impact flag to red. The source or destination host is potentially compromised by a virus, trojan, or other piece of malicious software.</li> <li>0x80 (bit 7) - There is a vulnerability mapped to the client detected in the event. (version 5.0+ only)</li> </ul> <p>The following impact level values map to specific priorities on the Defense Center. An x indicates the value can be 0 or 1:</p> <ul style="list-style-type: none"> <li>gray (0, unknown): 00X00000</li> <li>red (1, vulnerable): XXXX1XXX, XXX1XXXX, X1XXXXXX, 1XXXXXXX (version 5.0+ only)</li> <li>orange (2, potentially vulnerable): 00X0011X</li> <li>yellow (3, currently not vulnerable): 00X0001X</li> <li>blue (4, unknown target): 00X00001</li> </ul> |
| Source IP Address      | uint8[16] | IP address of the host associated with the impact event. This can contain either an IPv4 or IPv6 address. See <a href="#">IP Addresses, page 1-5</a> for more information.  |
| Destination IP Address | uint8[16] | IP address of the destination IP address associated with the impact event (if applicable). This can contain either an IPv4 or IPv6 address. See <a href="#">IP Addresses, page 1-5</a> for more information. This value is 0 if there is no destination IP address.   |
| String Block Type      | uint32    | Initiates a string data block that contains the impact name. This value is always set to 0. For more information about string blocks, see <a href="#">String Data Block, page 4-63</a> .  |

Table 3-5 Impact Event Data Fields (continued)

| Field               | Data Type | Description  |
|---------------------|-----------|--|
| String Block Length | uint32    | Number of bytes in the event description string block. This includes the four bytes for the string block type, the four bytes for the string block length, and the number of bytes in the description. |
| Description         | string    | Description of the impact event.   |

## User Record

When you request metadata, you can retrieve information about the users referenced in events generated by components in your FireSIGHT System. The eStreamer service transmits metadata containing user information for an event within a User record, the format of which is shown below. The user metadata record can be used to determine a user name associated with an event by correlating the metadata with the user ID value from a User Vulnerability Change Data Block, User Host Deletion Data Block, User Service Deletion Data Block, User Criticality Change Blocks, Attribute Definition Data Block, User Attribute Value Data Block, or Scan Result Data Block. (User information is sent when one of the metadata flags—bits 1, 14, 15, or 20 in the Request Flags field of a request message—is set. See [Request Flags, page 2-11](#).) Note that the Record Type field, which appears after the Message Length field, has a value of 62, indicating a User record.

| Byte | 0                  |   |   |   | 1 |   |   |   | 2                |   |    |    | 3  |    |    |    |    |    |    |    |    |    |    |    |    |    |    |    |    |    |    |    |
|------|--------------------|---|---|---|---|---|---|---|------------------|---|----|----|----|----|----|----|----|----|----|----|----|----|----|----|----|----|----|----|----|----|----|----|
| Bit  | 0                  | 1 | 2 | 3 | 4 | 5 | 6 | 7 | 8                | 9 | 10 | 11 | 12 | 13 | 14 | 15 | 16 | 17 | 18 | 19 | 20 | 21 | 22 | 23 | 24 | 25 | 26 | 27 | 28 | 29 | 30 | 31 |
|      | Header Version (1) |   |   |   |   |   |   |   | Message Type (4) |   |    |    |    |    |    |    |    |    |    |    |    |    |    |    |    |    |    |    |    |    |    |    |
|      | Message Length     |   |   |   |   |   |   |   |                  |   |    |    |    |    |    |    |    |    |    |    |    |    |    |    |    |    |    |    |    |    |    |    |
|      | Record Type (62)   |   |   |   |   |   |   |   |                  |   |    |    |    |    |    |    |    |    |    |    |    |    |    |    |    |    |    |    |    |    |    |    |
|      | Record Length      |   |   |   |   |   |   |   |                  |   |    |    |    |    |    |    |    |    |    |    |    |    |    |    |    |    |    |    |    |    |    |    |
|      | User ID            |   |   |   |   |   |   |   |                  |   |    |    |    |    |    |    |    |    |    |    |    |    |    |    |    |    |    |    |    |    |    |    |
|      | Name Length        |   |   |   |   |   |   |   |                  |   |    |    |    |    |    |    |    |    |    |    |    |    |    |    |    |    |    |    |    |    |    |    |
|      | Name...            |   |   |   |   |   |   |   |                  |   |    |    |    |    |    |    |    |    |    |    |    |    |    |    |    |    |    |    |    |    |    |    |

The following table describes the fields in the User record.

Table 3-6 User Record Fields

| Field       | Data Type | Description                                    |
|-------------|-----------|--|
| User ID     | uint32    | The user ID number.                            |
| Name Length | uint32    | The number of bytes included in the user name. |
| Name        | string    | The name of the user.                          |

## Rule Message Record for 4.6.1+

Rule message information for an event is transmitted within a Rule Message record, the format of which is shown below. The eStreamer service transmits the Rule Message record for 4.6.1+ when you request Version 2 or Version 3 metadata. The Rule Message record for 4.6.1+ contains the same fields as the Rule Message record for 4.6 and lower but also has new UUID and Revision UUID fields. (Version 2, Version 3, or Version 4 metadata information is sent when the appropriate metadata flag—bit 14 for Version 2, bit 15 for Version 3, or bit 20 for Version 4 in the Request Flags field of a request message—is set. See [Request Flags, page 2-11](#).) Note that the Record Type field, which appears after the Message Length field, has a value of 66, indicating a Rule Message Version 2 record.

| Byte               | 0                        |   |   |   |   |   |   |   | 1 |   |    |    |    |    |    |    | 2                  |    |    |    |    |    |    |    | 3  |    |    |    |    |    |    |    |
|--------------------|--------------------------|---|---|---|---|---|---|---|---|---|----|----|----|----|----|----|--------------------|----|----|----|----|----|----|----|----|----|----|----|----|----|----|----|
| Bit                | 0                        | 1 | 2 | 3 | 4 | 5 | 6 | 7 | 8 | 9 | 10 | 11 | 12 | 13 | 14 | 15 | 16                 | 17 | 18 | 19 | 20 | 21 | 22 | 23 | 24 | 25 | 26 | 27 | 28 | 29 | 30 | 31 |
|                    | Header Version (1)       |   |   |   |   |   |   |   |   |   |    |    |    |    |    |    | Message Type (4)   |    |    |    |    |    |    |    |    |    |    |    |    |    |    |    |
|                    | Message Length           |   |   |   |   |   |   |   |   |   |    |    |    |    |    |    |                    |    |    |    |    |    |    |    |    |    |    |    |    |    |    |    |
|                    | Record Type (66)         |   |   |   |   |   |   |   |   |   |    |    |    |    |    |    |                    |    |    |    |    |    |    |    |    |    |    |    |    |    |    |    |
|                    | Record Length            |   |   |   |   |   |   |   |   |   |    |    |    |    |    |    |                    |    |    |    |    |    |    |    |    |    |    |    |    |    |    |    |
| Signature Key      | Generator ID             |   |   |   |   |   |   |   |   |   |    |    |    |    |    |    |                    |    |    |    |    |    |    |    |    |    |    |    |    |    |    |    |
|                    | Rule ID                  |   |   |   |   |   |   |   |   |   |    |    |    |    |    |    |                    |    |    |    |    |    |    |    |    |    |    |    |    |    |    |    |
|                    | Revision Number          |   |   |   |   |   |   |   |   |   |    |    |    |    |    |    |                    |    |    |    |    |    |    |    |    |    |    |    |    |    |    |    |
|                    | Rendered Signature ID    |   |   |   |   |   |   |   |   |   |    |    |    |    |    |    |                    |    |    |    |    |    |    |    |    |    |    |    |    |    |    |    |
| Rule UUID          | Message Length           |   |   |   |   |   |   |   |   |   |    |    |    |    |    |    | Rule UUID          |    |    |    |    |    |    |    |    |    |    |    |    |    |    |    |
|                    | Rule UUID cont.          |   |   |   |   |   |   |   |   |   |    |    |    |    |    |    |                    |    |    |    |    |    |    |    |    |    |    |    |    |    |    |    |
|                    | Rule UUID cont.          |   |   |   |   |   |   |   |   |   |    |    |    |    |    |    |                    |    |    |    |    |    |    |    |    |    |    |    |    |    |    |    |
|                    | Rule UUID cont.          |   |   |   |   |   |   |   |   |   |    |    |    |    |    |    | Rule Revision UUID |    |    |    |    |    |    |    |    |    |    |    |    |    |    |    |
| Rule Revision UUID | Rule Revision UUID cont. |   |   |   |   |   |   |   |   |   |    |    |    |    |    |    |                    |    |    |    |    |    |    |    |    |    |    |    |    |    |    |    |
|                    | Rule Revision UUID cont. |   |   |   |   |   |   |   |   |   |    |    |    |    |    |    |                    |    |    |    |    |    |    |    |    |    |    |    |    |    |    |    |
|                    | Rule Revision UUID cont. |   |   |   |   |   |   |   |   |   |    |    |    |    |    |    |                    |    |    |    |    |    |    |    |    |    |    |    |    |    |    |    |
|                    | Rule Revision UUID cont. |   |   |   |   |   |   |   |   |   |    |    |    |    |    |    | Message...         |    |    |    |    |    |    |    |    |    |    |    |    |    |    |    |

The following table describes each rule-specific field.

**Table 3-7** Rule Message Record Fields

| Field                 | Data Type | Description  |
|-----------------------|-----------|--|
| Generator ID          | uint32    | The generator identification number.   |
| Rule ID               | uint32    | The rule identification number for the local computer.                       |
| Rule Revision         | uint32    | The rule revision number. This is currently set to 0 for all rule messages.  |
| Rendered Signature ID | uint32    | The rule identification number rendered to the FireSIGHT System interface.   |
| Message Length        | uint16    | The number of bytes included in the rule text.                               |
| UUID                  | uint8[16] | A rule ID number that acts as a unique identifier for the rule.              |
| Revision UUID         | uint8[16] | A rule revision ID number that acts as a unique identifier for the revision. |
| Message               | variable  | Rule message that triggered the event.                                       |

## Classification Record for 4.6.1+

The eStreamer service transmits the classification information for an event in a Classification record for 4.6.1+, the format of which is shown below. The Classification record for 4.6.1+ contains the same fields as the Classification record for 4.6 and lower but also has new UUID and Revision UUID fields. (Classification information is sent when the Version 3 or Version 4 metadata flag—bit 15 or bit 20 in the Request Flags field of a request message—is set. See [Request Flags, page 2-11](#).) Note that the Record Type field, which appears after the Message Length field, has a value of 67, indicating a Classification Version 2 record.

| Byte | 0                         |   |   |   |   |   |   |   | 1 |   |    |    |    |    |    |    | 2                |    |    |    |    |    |    |    | 3  |    |    |    |    |    |    |    |
|------|---------------------------|---|---|---|---|---|---|---|---|---|----|----|----|----|----|----|------------------|----|----|----|----|----|----|----|----|----|----|----|----|----|----|----|
| Bit  | 0                         | 1 | 2 | 3 | 4 | 5 | 6 | 7 | 8 | 9 | 10 | 11 | 12 | 13 | 14 | 15 | 16               | 17 | 18 | 19 | 20 | 21 | 22 | 23 | 24 | 25 | 26 | 27 | 28 | 29 | 30 | 31 |
|      | Header Version (1)        |   |   |   |   |   |   |   |   |   |    |    |    |    |    |    | Message Type (4) |    |    |    |    |    |    |    |    |    |    |    |    |    |    |    |
|      | Message Length            |   |   |   |   |   |   |   |   |   |    |    |    |    |    |    |                  |    |    |    |    |    |    |    |    |    |    |    |    |    |    |    |
|      | Record Type (67)          |   |   |   |   |   |   |   |   |   |    |    |    |    |    |    |                  |    |    |    |    |    |    |    |    |    |    |    |    |    |    |    |
|      | Record Length             |   |   |   |   |   |   |   |   |   |    |    |    |    |    |    |                  |    |    |    |    |    |    |    |    |    |    |    |    |    |    |    |
|      | Classification ID         |   |   |   |   |   |   |   |   |   |    |    |    |    |    |    |                  |    |    |    |    |    |    |    |    |    |    |    |    |    |    |    |
|      | Name Length               |   |   |   |   |   |   |   |   |   |    |    |    |    |    |    | Name...          |    |    |    |    |    |    |    |    |    |    |    |    |    |    |    |
|      | Name, continued...        |   |   |   |   |   |   |   |   |   |    |    |    |    |    |    |                  |    |    |    |    |    |    |    |    |    |    |    |    |    |    |    |
|      | Description Length        |   |   |   |   |   |   |   |   |   |    |    |    |    |    |    | Description...   |    |    |    |    |    |    |    |    |    |    |    |    |    |    |    |
|      | Description, continued... |   |   |   |   |   |   |   |   |   |    |    |    |    |    |    |                  |    |    |    |    |    |    |    |    |    |    |    |    |    |    |    |

| Byte                         | 0                                       |   |   |   |   |   |   |   | 1 |   |    |    |    |    |    |    | 2  |    |    |    |    |    |    |    | 3  |    |    |    |    |    |    |    |
|------------------------------|---|---|---|---|---|---|---|---|---|---|----|----|----|----|----|----|----|----|----|----|----|----|----|----|----|----|----|----|----|----|----|----|
| Bit                          | 0                                       | 1 | 2 | 3 | 4 | 5 | 6 | 7 | 8 | 9 | 10 | 11 | 12 | 13 | 14 | 15 | 16 | 17 | 18 | 19 | 20 | 21 | 22 | 23 | 24 | 25 | 26 | 27 | 28 | 29 | 30 | 31 |
| Classification UUID          | Classification UUID                     |   |   |   |   |   |   |   |   |   |    |    |    |    |    |    |    |    |    |    |    |    |    |    |    |    |    |    |    |    |    |    |
|                              | Classification UUID, continued          |   |   |   |   |   |   |   |   |   |    |    |    |    |    |    |    |    |    |    |    |    |    |    |    |    |    |    |    |    |    |    |
|                              | Classification UUID, continued          |   |   |   |   |   |   |   |   |   |    |    |    |    |    |    |    |    |    |    |    |    |    |    |    |    |    |    |    |    |    |    |
|                              | Classification UUID, continued          |   |   |   |   |   |   |   |   |   |    |    |    |    |    |    |    |    |    |    |    |    |    |    |    |    |    |    |    |    |    |    |
| Classification Revision UUID | Classification Revision UUID            |   |   |   |   |   |   |   |   |   |    |    |    |    |    |    |    |    |    |    |    |    |    |    |    |    |    |    |    |    |    |    |
|                              | Classification Revision UUID, continued |   |   |   |   |   |   |   |   |   |    |    |    |    |    |    |    |    |    |    |    |    |    |    |    |    |    |    |    |    |    |    |
|                              | Classification Revision UUID, continued |   |   |   |   |   |   |   |   |   |    |    |    |    |    |    |    |    |    |    |    |    |    |    |    |    |    |    |    |    |    |    |
|                              | Classification Revision UUID, continued |   |   |   |   |   |   |   |   |   |    |    |    |    |    |    |    |    |    |    |    |    |    |    |    |    |    |    |    |    |    |    |

The following table describes the fields in the Classification record.

**Table 3-8** Classification Record Fields

| Field              | Data Type | Description   |
|--------------------|-----------|---|
| Classification ID  | uint32    | The classification ID number.   |
| Name Length        | uint16    | The number of bytes included in the name.   |
| Name               | string    | The classification name.  |
| Description Length | uint16    | The number of bytes included in the description.  |
| Description        | string    | The classification description.   |
| UUID               | uint8[16] | A classification ID number that acts as a unique identifier for the classification.                   |
| Revision UUID      | uint8[16] | A classification revision ID number that acts as a unique identifier for the classification revision. |

## Correlation Policy Record

The eStreamer service transmits metadata containing the correlation policy for a correlation event within a Correlation Policy record, the format of which is shown below. (Correlation policy information is sent when the Version 3 or Version 4 metadata flag—bit 15 or bit 20 in the Request Flags field of a request message—is set. See [Request Flags, page 2-11](#).) Note that the Record Type field, which appears after the Message Length field, has a value of 69, indicating a Correlation Policy record.



|                                  |   |   |   |   |   |   |   |   |   |   |    |    |    |    |    |    |                  |    |    |    |    |    |    |    |    |    |    |    |    |    |    |    |
|----------------------------------|---|---|---|---|---|---|---|---|---|---|----|----|----|----|----|----|------------------|----|----|----|----|----|----|----|----|----|----|----|----|----|----|----|
| Byte                             | 0   |   |   |   |   |   |   |   | 1 |   |    |    |    |    |    |    | 2                |    |    |    |    |    |    |    | 3  |    |    |    |    |    |    |    |
| Bit                              | 0   | 1 | 2 | 3 | 4 | 5 | 6 | 7 | 8 | 9 | 10 | 11 | 12 | 13 | 14 | 15 | 16               | 17 | 18 | 19 | 20 | 21 | 22 | 23 | 24 | 25 | 26 | 27 | 28 | 29 | 30 | 31 |
|                                  | Header Version (1)                          |   |   |   |   |   |   |   |   |   |    |    |    |    |    |    | Message Type (4) |    |    |    |    |    |    |    |    |    |    |    |    |    |    |    |
|                                  | Message Length                              |   |   |   |   |   |   |   |   |   |    |    |    |    |    |    |                  |    |    |    |    |    |    |    |    |    |    |    |    |    |    |    |
|                                  | Record Type (69)                            |   |   |   |   |   |   |   |   |   |    |    |    |    |    |    |                  |    |    |    |    |    |    |    |    |    |    |    |    |    |    |    |
|                                  | Record Length                               |   |   |   |   |   |   |   |   |   |    |    |    |    |    |    |                  |    |    |    |    |    |    |    |    |    |    |    |    |    |    |    |
|                                  | Correlation Policy ID                       |   |   |   |   |   |   |   |   |   |    |    |    |    |    |    |                  |    |    |    |    |    |    |    |    |    |    |    |    |    |    |    |
|                                  | Name Length                                 |   |   |   |   |   |   |   |   |   |    |    |    |    |    |    |                  |    |    |    |    |    |    |    |    |    |    |    |    |    |    |    |
|                                  | Name...                                     |   |   |   |   |   |   |   |   |   |    |    |    |    |    |    |                  |    |    |    |    |    |    |    |    |    |    |    |    |    |    |    |
|                                  | Description Length                          |   |   |   |   |   |   |   |   |   |    |    |    |    |    |    |                  |    |    |    |    |    |    |    |    |    |    |    |    |    |    |    |
|                                  | Description...                              |   |   |   |   |   |   |   |   |   |    |    |    |    |    |    |                  |    |    |    |    |    |    |    |    |    |    |    |    |    |    |    |
| Correlation Policy UUID          | Correlation Policy UUID                     |   |   |   |   |   |   |   |   |   |    |    |    |    |    |    |                  |    |    |    |    |    |    |    |    |    |    |    |    |    |    |    |
|                                  | Correlation Policy UUID, continued          |   |   |   |   |   |   |   |   |   |    |    |    |    |    |    |                  |    |    |    |    |    |    |    |    |    |    |    |    |    |    |    |
|                                  | Correlation Policy UUID, continued          |   |   |   |   |   |   |   |   |   |    |    |    |    |    |    |                  |    |    |    |    |    |    |    |    |    |    |    |    |    |    |    |
|                                  | Correlation Policy UUID, continued          |   |   |   |   |   |   |   |   |   |    |    |    |    |    |    |                  |    |    |    |    |    |    |    |    |    |    |    |    |    |    |    |
| Correlation Policy Revision UUID | Correlation Policy Revision UUID            |   |   |   |   |   |   |   |   |   |    |    |    |    |    |    |                  |    |    |    |    |    |    |    |    |    |    |    |    |    |    |    |
|                                  | Correlation Policy Revision UUID, continued |   |   |   |   |   |   |   |   |   |    |    |    |    |    |    |                  |    |    |    |    |    |    |    |    |    |    |    |    |    |    |    |
|                                  | Correlation Policy Revision UUID, continued |   |   |   |   |   |   |   |   |   |    |    |    |    |    |    |                  |    |    |    |    |    |    |    |    |    |    |    |    |    |    |    |
|                                  | Correlation Policy Revision UUID, continued |   |   |   |   |   |   |   |   |   |    |    |    |    |    |    |                  |    |    |    |    |    |    |    |    |    |    |    |    |    |    |    |

The following table describes the fields in the Correlation Policy record.

**Table 3-9 Correlation Policy Record Fields**

| Field                 | Data Type | Description   |
|-----------------------|-----------|---|
| Correlation Policy ID | uint32    | The correlation policy ID number.                                   |
| Name Length           | uint16    | The number of bytes included in the correlation policy name.        |
| Name                  | string    | The name of the correlation policy that triggered the event.        |
| Description Length    | uint16    | The number of bytes included in the correlation policy description. |
| Description           | string    | The description of the correlation policy that triggered the event. |

Table 3-9 Correlation Policy Record Fields (continued)

| Field         | Data Type | Description  |
|---------------|-----------|--|
| UUID          | uint8[16] | A correlation policy ID number that acts as a unique identifier for the correlation policy.          |
| Revision UUID | uint8[16] | A correlation policy revision ID number that acts as a unique identifier for the correlation policy. |

## Correlation Rule Record

The eStreamer service transmits metadata containing information on the correlation rule that triggered a correlation event within a Correlation Rule record, the format of which is shown below. (Correlation rule information is sent when the Version 3 or Version 4 metadata flag—bit 15 or bit 20 in the Request Flags field of a request message—is set. See [Request Flags, page 2-11](#).) Note that the Record Type field, which appears after the Message Length field, has a value of 70, indicating a Correlation Rule record.

| Byte                  | 0                                |   |   |   |   |   |   |   | 1 |   |    |    |    |    |    |    | 2                          |    |    |    |    |    |    |    | 3  |    |    |    |    |    |    |    |
|-----------------------|----------------------------------|---|---|---|---|---|---|---|---|---|----|----|----|----|----|----|----------------------------|----|----|----|----|----|----|----|----|----|----|----|----|----|----|----|
|                       | 0                                | 1 | 2 | 3 | 4 | 5 | 6 | 7 | 8 | 9 | 10 | 11 | 12 | 13 | 14 | 15 | 16                         | 17 | 18 | 19 | 20 | 21 | 22 | 23 | 24 | 25 | 26 | 27 | 28 | 29 | 30 | 31 |
| Bit                   | Header Version (1)               |   |   |   |   |   |   |   |   |   |    |    |    |    |    |    | Message Type (4)           |    |    |    |    |    |    |    |    |    |    |    |    |    |    |    |
|                       | Message Length                   |   |   |   |   |   |   |   |   |   |    |    |    |    |    |    |                            |    |    |    |    |    |    |    |    |    |    |    |    |    |    |    |
|                       | Record Type (70)                 |   |   |   |   |   |   |   |   |   |    |    |    |    |    |    |                            |    |    |    |    |    |    |    |    |    |    |    |    |    |    |    |
|                       | Record Length                    |   |   |   |   |   |   |   |   |   |    |    |    |    |    |    |                            |    |    |    |    |    |    |    |    |    |    |    |    |    |    |    |
|                       | Correlation Rule ID              |   |   |   |   |   |   |   |   |   |    |    |    |    |    |    |                            |    |    |    |    |    |    |    |    |    |    |    |    |    |    |    |
|                       | Name Length                      |   |   |   |   |   |   |   |   |   |    |    |    |    |    |    | Name...                    |    |    |    |    |    |    |    |    |    |    |    |    |    |    |    |
|                       | Name...                          |   |   |   |   |   |   |   |   |   |    |    |    |    |    |    | Description Length         |    |    |    |    |    |    |    |    |    |    |    |    |    |    |    |
|                       | Description...                   |   |   |   |   |   |   |   |   |   |    |    |    |    |    |    |                            |    |    |    |    |    |    |    |    |    |    |    |    |    |    |    |
|                       | Event Type Length                |   |   |   |   |   |   |   |   |   |    |    |    |    |    |    | Event Type...              |    |    |    |    |    |    |    |    |    |    |    |    |    |    |    |
|                       | Event Type...                    |   |   |   |   |   |   |   |   |   |    |    |    |    |    |    | Correlation Rule UUID      |    |    |    |    |    |    |    |    |    |    |    |    |    |    |    |
| Correlation Rule UUID | Correlation Rule UUID, continued |   |   |   |   |   |   |   |   |   |    |    |    |    |    |    |                            |    |    |    |    |    |    |    |    |    |    |    |    |    |    |    |
|                       | Correlation Rule UUID, continued |   |   |   |   |   |   |   |   |   |    |    |    |    |    |    |                            |    |    |    |    |    |    |    |    |    |    |    |    |    |    |    |
|                       | Correlation Rule UUID, continued |   |   |   |   |   |   |   |   |   |    |    |    |    |    |    |                            |    |    |    |    |    |    |    |    |    |    |    |    |    |    |    |
|                       | Correlation Rule UUID, continued |   |   |   |   |   |   |   |   |   |    |    |    |    |    |    | Correlation Revision UUID, |    |    |    |    |    |    |    |    |    |    |    |    |    |    |    |

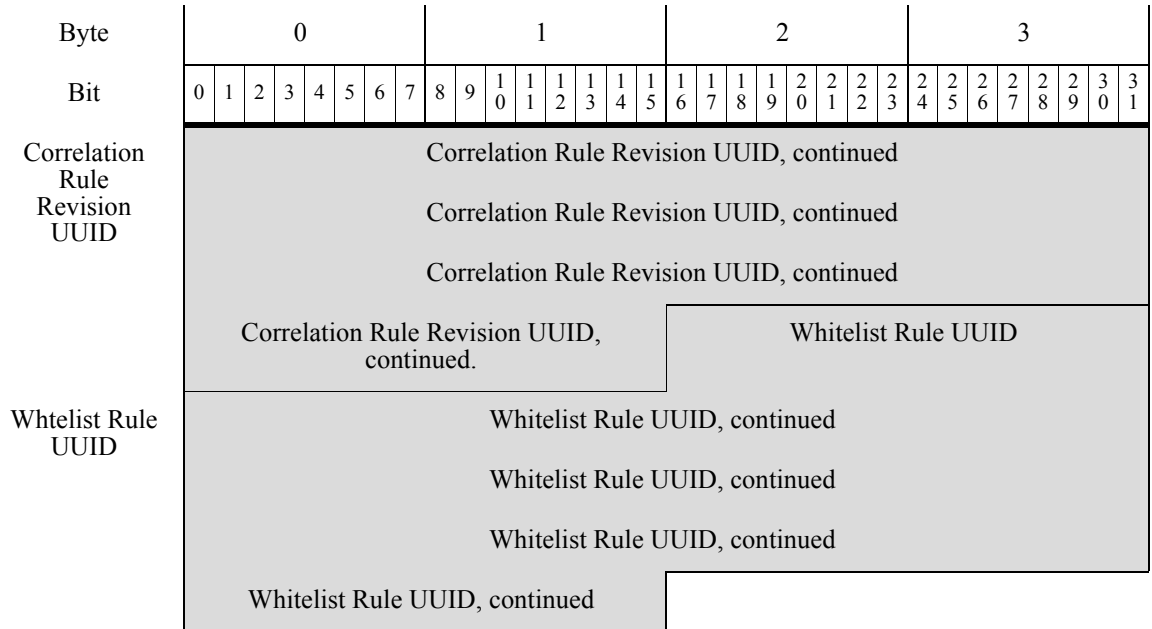

The following table describes the fields in the Correlation Rule record.

**Table 3-10** Correlation Rule Record Fields

| Field               | Data Type | Description   |
|---------------------|-----------|---|
| Correlation Rule ID | uint32    | The correlation rule ID number.   |
| Name Length         | uint16    | The number of bytes included in the correlation rule name.  |
| Name                | string    | The name of the correlation rule that triggered the event.  |
| Description Length  | uint16    | The number of bytes included in the correlation rule description.   |
| Description         | string    | The description of the correlation rule that triggered the event.   |
| Event Type Length   | uint16    | The number of bytes included in the event type description.   |
| Event Type          | string    | The description of the event that triggered the correlation rule.   |
| UUID                | uint8[16] | A correlation rule ID number that acts as a unique identifier for the correlation rule.                           |
| Revision UUID       | uint8[16] | A correlation rule revision ID number that acts as a unique identifier for the correlation rule revision.         |
| Whitelist UUID      | uint8[16] | A correlation ID number that acts as a unique identifier for the event sent as a result of a whitelist violation. |

## Intrusion Event Extra Data Record

The eStreamer service transmits the event extra data associated with an intrusion event in the Intrusion Event Extra Data record. The record type is always 110.

The event extra data appears in an encapsulated Event Extra Data data block, which always has a data block type value of 4. (The Event Extra Data data block is a series 2 data block. For more information about series 2 data blocks, see [Understanding Series 2 Data Blocks, page 3-44.](#))

The supported types of extra data include IPv6 source and destination addresses, as well as the originating IP addresses (v4 or v6) of clients connecting to a web server through an HTTP proxy or load balancer. The graphic below shows the format of the Intrusion Event Extra Data record.

If bit 27 is set in the Request Flags field of the request message, you receive the event extra data for each intrusion event. If you set bit 20, you also receive the event extra data metadata described in [Intrusion Event Extra Data Metadata, page 3-23](#). If you enable bit 23, eStreamer will include the extended event header. See [Request Flags, page 2-11](#) for information on setting request flags.

| Byte | 0   |   |   |   |   |   |   |   | 1 |   |    |    |    |    |    |    | 2                |    |    |    |    |    |    |    | 3  |    |    |    |    |    |    |    |
|------|---|---|---|---|---|---|---|---|---|---|----|----|----|----|----|----|------------------|----|----|----|----|----|----|----|----|----|----|----|----|----|----|----|
| Bit  | 0   | 1 | 2 | 3 | 4 | 5 | 6 | 7 | 8 | 9 | 10 | 11 | 12 | 13 | 14 | 15 | 16               | 17 | 18 | 19 | 20 | 21 | 22 | 23 | 24 | 25 | 26 | 27 | 28 | 29 | 30 | 31 |
|      | Header Version (1)  |   |   |   |   |   |   |   |   |   |    |    |    |    |    |    | Message Type (4) |    |    |    |    |    |    |    |    |    |    |    |    |    |    |    |
|      | Message Length  |   |   |   |   |   |   |   |   |   |    |    |    |    |    |    |                  |    |    |    |    |    |    |    |    |    |    |    |    |    |    |    |
|      | Record Type (110)   |   |   |   |   |   |   |   |   |   |    |    |    |    |    |    |                  |    |    |    |    |    |    |    |    |    |    |    |    |    |    |    |
|      | Record Length   |   |   |   |   |   |   |   |   |   |    |    |    |    |    |    |                  |    |    |    |    |    |    |    |    |    |    |    |    |    |    |    |
|      | eStreamer Server Timestamp (in events, only if bit 23 is set) |   |   |   |   |   |   |   |   |   |    |    |    |    |    |    |                  |    |    |    |    |    |    |    |    |    |    |    |    |    |    |    |
|      | Reserved for Future Use (in events, only if bit 23 is set)    |   |   |   |   |   |   |   |   |   |    |    |    |    |    |    |                  |    |    |    |    |    |    |    |    |    |    |    |    |    |    |    |
|      | Event Extra Data Data Block Type (4)                          |   |   |   |   |   |   |   |   |   |    |    |    |    |    |    |                  |    |    |    |    |    |    |    |    |    |    |    |    |    |    |    |
|      | Event Extra Data Data Block Length                            |   |   |   |   |   |   |   |   |   |    |    |    |    |    |    |                  |    |    |    |    |    |    |    |    |    |    |    |    |    |    |    |
|      | Device ID   |   |   |   |   |   |   |   |   |   |    |    |    |    |    |    |                  |    |    |    |    |    |    |    |    |    |    |    |    |    |    |    |
|      | Event ID  |   |   |   |   |   |   |   |   |   |    |    |    |    |    |    |                  |    |    |    |    |    |    |    |    |    |    |    |    |    |    |    |
|      | Event Second  |   |   |   |   |   |   |   |   |   |    |    |    |    |    |    |                  |    |    |    |    |    |    |    |    |    |    |    |    |    |    |    |
|      | Type  |   |   |   |   |   |   |   |   |   |    |    |    |    |    |    |                  |    |    |    |    |    |    |    |    |    |    |    |    |    |    |    |
|      | BLOB Block Type (1)   |   |   |   |   |   |   |   |   |   |    |    |    |    |    |    |                  |    |    |    |    |    |    |    |    |    |    |    |    |    |    |    |
|      | BLOB Length   |   |   |   |   |   |   |   |   |   |    |    |    |    |    |    |                  |    |    |    |    |    |    |    |    |    |    |    |    |    |    |    |
|      | Event Extra Data  |   |   |   |   |   |   |   |   |   |    |    |    |    |    |    |                  |    |    |    |    |    |    |    |    |    |    |    |    |    |    |    |

Note that the Event Extra Data block structure includes a BLOB block type, which is one of several variable length data structures introduced in Version 4.10 of the FireSIGHT System.

The following table describes the fields in the Intrusion Event Extra Data record.

**Table 3-11** *Intrusion Event Extra Data Data Block Fields*

| Field                              | Data Type | Description   |
|------------------------------------|-----------|---|
| Event Extra Data Data Block Type   | uint32    | Initiates an Event Extra Data data block. This value is always 4. The block type is a series 2 block; for information see <a href="#">Understanding Series 2 Data Blocks, page 3-44</a> . |
| Event Extra Data Data Block Length | uint32    | Length of the data block. Includes the number of bytes of data plus the 8 bytes in the two data block header fields.  |
| Device ID                          | uint32    | The managed device identification number.   |
| Event ID                           | uint32    | The event identification number.  |
| Event Second                       | uint32    | UNIX timestamp of the event (seconds since 01/01/1970).   |
| Type                               | uint32    | Identifier for the type of extra data; for example: <ul style="list-style-type: none"> <li>1 - XFF client (IPv4)</li> <li>2 - XFF client (IPv6)</li> <li>9 - HTTP URI</li> </ul>          |
| BLOB Block Type                    | uint32    | Initiates a BLOB data block containing extra data. This value is always 1. The block type is a series 2 block.  |
| Length                             | uint32    | Total number of bytes in the BLOB data block.   |
| Extra Data                         | variable  | The content of the extra data. The data type is indicated in the Type field.  |

## Intrusion Event Extra Data Metadata

The eStreamer service transmits the event extra data metadata associated with intrusion event extra data records in the Intrusion Event Extra Data Metadata record. The record type is always 111.

The event extra data metadata appears in an encapsulated Event Extra Data Metadata data block, which always has a data block type value of 5. The Event Extra Data data block is a series 2 data block.

If bit 20 is set in the Request Flags field of a request message, you receive the event extra data metadata. If you want to receive both intrusion events and event extra data metadata, you must set bit 2 as well. See [Request Flags, page 2-11](#). If you enable bit 23, an extended event header is included in the record.

| Byte | 0                  |   |   |   |   |   |   |   | 1 |   |    |    |    |    |    |    | 2                |    |    |    |    |    |    |    | 3  |    |    |    |    |    |    |    |
|------|--------------------|---|---|---|---|---|---|---|---|---|----|----|----|----|----|----|------------------|----|----|----|----|----|----|----|----|----|----|----|----|----|----|----|
| Bit  | 0                  | 1 | 2 | 3 | 4 | 5 | 6 | 7 | 8 | 9 | 10 | 11 | 12 | 13 | 14 | 15 | 16               | 17 | 18 | 19 | 20 | 21 | 22 | 23 | 24 | 25 | 26 | 27 | 28 | 29 | 30 | 31 |
|      | Header Version (1) |   |   |   |   |   |   |   |   |   |    |    |    |    |    |    | Message Type (4) |    |    |    |    |    |    |    |    |    |    |    |    |    |    |    |
|      | Message Length     |   |   |   |   |   |   |   |   |   |    |    |    |    |    |    |                  |    |    |    |    |    |    |    |    |    |    |    |    |    |    |    |
|      | Record Type (111)  |   |   |   |   |   |   |   |   |   |    |    |    |    |    |    |                  |    |    |    |    |    |    |    |    |    |    |    |    |    |    |    |
|      | Record Length      |   |   |   |   |   |   |   |   |   |    |    |    |    |    |    |                  |    |    |    |    |    |    |    |    |    |    |    |    |    |    |    |

| Byte  | 0 |   |   |   |   |   |   |   | 1 |   |    |    |    |    |    |    | 2  |    |    |    |    |    |    |    | 3  |    |    |    |    |    |    |    |
|---|---|---|---|---|---|---|---|---|---|---|----|----|----|----|----|----|----|----|----|----|----|----|----|----|----|----|----|----|----|----|----|----|
| Bit   | 0 | 1 | 2 | 3 | 4 | 5 | 6 | 7 | 8 | 9 | 10 | 11 | 12 | 13 | 14 | 15 | 16 | 17 | 18 | 19 | 20 | 21 | 22 | 23 | 24 | 25 | 26 | 27 | 28 | 29 | 30 | 31 |
| eStreamer Server Timestamp (in events, only if bit 23 is set) |   |   |   |   |   |   |   |   |   |   |    |    |    |    |    |    |    |    |    |    |    |    |    |    |    |    |    |    |    |    |    |    |
| Reserved for Future Use (in events, only if bit 23 is set)    |   |   |   |   |   |   |   |   |   |   |    |    |    |    |    |    |    |    |    |    |    |    |    |    |    |    |    |    |    |    |    |    |
| Event Extra Data Metadata Data Block Type (5)                 |   |   |   |   |   |   |   |   |   |   |    |    |    |    |    |    |    |    |    |    |    |    |    |    |    |    |    |    |    |    |    |    |
| Data Block Length   |   |   |   |   |   |   |   |   |   |   |    |    |    |    |    |    |    |    |    |    |    |    |    |    |    |    |    |    |    |    |    |    |
| Type  |   |   |   |   |   |   |   |   |   |   |    |    |    |    |    |    |    |    |    |    |    |    |    |    |    |    |    |    |    |    |    |    |
| String Block Type (0)   |   |   |   |   |   |   |   |   |   |   |    |    |    |    |    |    |    |    |    |    |    |    |    |    |    |    |    |    |    |    |    |    |
| String Block Length   |   |   |   |   |   |   |   |   |   |   |    |    |    |    |    |    |    |    |    |    |    |    |    |    |    |    |    |    |    |    |    |    |
| Name...   |   |   |   |   |   |   |   |   |   |   |    |    |    |    |    |    |    |    |    |    |    |    |    |    |    |    |    |    |    |    |    |    |
| String Block Type (0)   |   |   |   |   |   |   |   |   |   |   |    |    |    |    |    |    |    |    |    |    |    |    |    |    |    |    |    |    |    |    |    |    |
| String Block Length   |   |   |   |   |   |   |   |   |   |   |    |    |    |    |    |    |    |    |    |    |    |    |    |    |    |    |    |    |    |    |    |    |
| Encoding  |   |   |   |   |   |   |   |   |   |   |    |    |    |    |    |    |    |    |    |    |    |    |    |    |    |    |    |    |    |    |    |    |

Note that the block structure includes encapsulated String block types, one of several series 2 variable length data structures introduced in Version 4.10 of the FireSIGHT System.

The following table describes the fields in the Event Extra Data Metadata record.

**Table 3-12** Event Extra Data Metadata Data Block Fields

| Field                                       | Data Type | Description   |
|---|-----------|---|
| Event Extra Data Metadata Data Block Type   | uint32    | Initiates an Event Extra Data Metadata data block. This value is always 5. This block type is a series 2 block.   |
| Event Extra Data Metadata Data Block Length | uint32    | Length of the data block. Includes the number of bytes of data plus the 8 bytes in the two data block header fields.  |
| Type  | uint32    | The type of extra data. Matches the Type field in the associated Event Extra Data record.   |
| String Block Type                           | uint32    | Initiates a String data block for the client application version. This value is always 0. This block type is a series 2 block.  |
| String Block Length                         | uint32    | Number of bytes in the client application version String data block, including eight bytes for the string block type and length fields, plus the number of bytes in the version string. |
| Name  | string    | Name of the type of event extra data, for example, XFF client (IPv6), and HTTP URI.   |
| String Block Type                           | uint32    | Initiates a string data block for the client application URL. This value is always 0. This block type is a series 2 block.  |

Table 3-12 Event Extra Data Metadata Data Block Fields (continued)

| Field               | Data Type | Description   |
|---------------------|-----------|---|
| String Block Length | uint32    | Number of bytes in the client application URL String data block, including eight bytes for the string block type and length fields, plus the number of bytes in the URL string. |
| Encoding            | string    | Encoding used for the event extra data, for example, IPv4, IPv6, or string.   |

## Security Zone Name Record

The eStreamer service transmits metadata containing information on the name of the security zone associated with an intrusion event or connection event within a Security Zone Name record, the format of which is shown below. (Security zone information is sent when the Version 4 metadata flag—bit 20 in the Request Flags field of a request message—is set. See [Request Flags, page 2-11](#).) Note that the Record Type field, which appears after the Message Length field, has a value of 115, indicating a Security Zone Name record. It contains a UUID String data block, block type 14 in the series 2 set of data blocks.

| Byte | 0                                    |   |   |   |   |   |   |   | 1 |   |    |    |    |    |    |    | 2                |    |    |    |    |    |    |    | 3  |    |    |    |    |    |    |    |
|------|--------------------------------------|---|---|---|---|---|---|---|---|---|----|----|----|----|----|----|------------------|----|----|----|----|----|----|----|----|----|----|----|----|----|----|----|
| Bit  | 0                                    | 1 | 2 | 3 | 4 | 5 | 6 | 7 | 8 | 9 | 10 | 11 | 12 | 13 | 14 | 15 | 16               | 17 | 18 | 19 | 20 | 21 | 22 | 23 | 24 | 25 | 26 | 27 | 28 | 29 | 30 | 31 |
|      | Header Version (1)                   |   |   |   |   |   |   |   |   |   |    |    |    |    |    |    | Message Type (4) |    |    |    |    |    |    |    |    |    |    |    |    |    |    |    |
|      | Message Length                       |   |   |   |   |   |   |   |   |   |    |    |    |    |    |    |                  |    |    |    |    |    |    |    |    |    |    |    |    |    |    |    |
|      | Record Type (115)                    |   |   |   |   |   |   |   |   |   |    |    |    |    |    |    |                  |    |    |    |    |    |    |    |    |    |    |    |    |    |    |    |
|      | Record Length                        |   |   |   |   |   |   |   |   |   |    |    |    |    |    |    |                  |    |    |    |    |    |    |    |    |    |    |    |    |    |    |    |
|      | Security Zone Name Data Block (14)   |   |   |   |   |   |   |   |   |   |    |    |    |    |    |    |                  |    |    |    |    |    |    |    |    |    |    |    |    |    |    |    |
|      | Security Zone Name Data Block Length |   |   |   |   |   |   |   |   |   |    |    |    |    |    |    |                  |    |    |    |    |    |    |    |    |    |    |    |    |    |    |    |
|      | Security Zone UUID                   |   |   |   |   |   |   |   |   |   |    |    |    |    |    |    |                  |    |    |    |    |    |    |    |    |    |    |    |    |    |    |    |
|      | String Block Type (0)                |   |   |   |   |   |   |   |   |   |    |    |    |    |    |    |                  |    |    |    |    |    |    |    |    |    |    |    |    |    |    |    |
|      | String Block Length                  |   |   |   |   |   |   |   |   |   |    |    |    |    |    |    |                  |    |    |    |    |    |    |    |    |    |    |    |    |    |    |    |
|      | Security Zone Name...                |   |   |   |   |   |   |   |   |   |    |    |    |    |    |    |                  |    |    |    |    |    |    |    |    |    |    |    |    |    |    |    |

The following table describes the fields in the Security Zone Name data block.

**Table 3-13** Security Zone Name Data Block Fields

| Field                                | Data Type | Description  |
|--------------------------------------|-----------|--|
| Security Zone Name Data Block Type   | uint32    | Initiates a Security Zone Name data block. This value is always 14. The block type is a series 2 block.  |
| Security Zone Name Data Block Length | uint32    | Length of the data block. Includes the number of bytes of data plus the 8 bytes in the two data block header fields.   |
| Security Zone UUID                   | uint8[16] | The unique identifier for the security zone associated with the connection event.  |
| String Block Type                    | uint32    | Initiates a String data block containing the name of the security zone. This value is always 0.  |
| String Block Length                  | uint32    | The number of bytes included in the security zone name String data block, including eight bytes for the block type and header fields plus the number of bytes in the name. |
| Security Zone Name                   | string    | The security zone name.  |

## Interface Name Record

The eStreamer service transmits metadata containing information on the name of the interface associated with an intrusion event or connection event within an Interface Name record, the format of which is shown below. (Interface name information is sent when the Version 4 metadata flag—bit 20 in the Request Flags field of a request message—is set. See [Request Flags, page 2-11](#).) Note that the Record Type field, which appears after the Message Length field, has a value of 116, indicating an Interface Name record. It contains a UUID String data block, block type 14 in the series 2 set of data blocks.

| Byte | 0                                |   |   |   |   |   |   |   | 1 |   |    |    |    |    |    |    | 2                |    |    |    |    |    |    |    | 3  |    |    |    |    |    |    |    |
|------|----------------------------------|---|---|---|---|---|---|---|---|---|----|----|----|----|----|----|------------------|----|----|----|----|----|----|----|----|----|----|----|----|----|----|----|
| Bit  | 0                                | 1 | 2 | 3 | 4 | 5 | 6 | 7 | 8 | 9 | 10 | 11 | 12 | 13 | 14 | 15 | 16               | 17 | 18 | 19 | 20 | 21 | 22 | 23 | 24 | 25 | 26 | 27 | 28 | 29 | 30 | 31 |
|      | Header Version (1)               |   |   |   |   |   |   |   |   |   |    |    |    |    |    |    | Message Type (4) |    |    |    |    |    |    |    |    |    |    |    |    |    |    |    |
|      | Message Length                   |   |   |   |   |   |   |   |   |   |    |    |    |    |    |    |                  |    |    |    |    |    |    |    |    |    |    |    |    |    |    |    |
|      | Record Type (116)                |   |   |   |   |   |   |   |   |   |    |    |    |    |    |    |                  |    |    |    |    |    |    |    |    |    |    |    |    |    |    |    |
|      | Record Length                    |   |   |   |   |   |   |   |   |   |    |    |    |    |    |    |                  |    |    |    |    |    |    |    |    |    |    |    |    |    |    |    |
|      | Interface Name Data Block (14)   |   |   |   |   |   |   |   |   |   |    |    |    |    |    |    |                  |    |    |    |    |    |    |    |    |    |    |    |    |    |    |    |
|      | Interface Name Data Block Length |   |   |   |   |   |   |   |   |   |    |    |    |    |    |    |                  |    |    |    |    |    |    |    |    |    |    |    |    |    |    |    |
|      | Interface UUID                   |   |   |   |   |   |   |   |   |   |    |    |    |    |    |    |                  |    |    |    |    |    |    |    |    |    |    |    |    |    |    |    |
|      | String Block Type (0)            |   |   |   |   |   |   |   |   |   |    |    |    |    |    |    |                  |    |    |    |    |    |    |    |    |    |    |    |    |    |    |    |



|                     |   |   |   |   |   |   |   |   |   |   |    |    |    |    |    |    |    |    |    |    |    |    |    |    |    |    |    |    |    |    |    |    |
|---------------------|---|---|---|---|---|---|---|---|---|---|----|----|----|----|----|----|----|----|----|----|----|----|----|----|----|----|----|----|----|----|----|----|
| Byte                | 0 |   |   |   |   |   |   |   | 1 |   |    |    |    |    |    |    | 2  |    |    |    |    |    |    |    | 3  |    |    |    |    |    |    |    |
| Bit                 | 0 | 1 | 2 | 3 | 4 | 5 | 6 | 7 | 8 | 9 | 10 | 11 | 12 | 13 | 14 | 15 | 16 | 17 | 18 | 19 | 20 | 21 | 22 | 23 | 24 | 25 | 26 | 27 | 28 | 29 | 30 | 31 |
| String Block Length |   |   |   |   |   |   |   |   |   |   |    |    |    |    |    |    |    |    |    |    |    |    |    |    |    |    |    |    |    |    |    |    |
| Interface Name...   |   |   |   |   |   |   |   |   |   |   |    |    |    |    |    |    |    |    |    |    |    |    |    |    |    |    |    |    |    |    |    |    |

The following table describes the fields in the Interface Name data block.

*Table 3-14 Interface Name Data Block Fields*

| Field                            | Data Type | Description  |
|----------------------------------|-----------|--|
| Interface Name Data Block Type   | uint32    | Initiates an Interface Name data block. This value is always 14. The block type is a series 2 block.   |
| Interface Name Data Block Length | uint32    | Length of the data block. Includes the number of bytes of data plus the 8 bytes in the two data block header fields.   |
| Interface UUID                   | uint8[16] | An interface ID number that acts as a unique identifier for the interface associated with the connection event.  |
| String Block Type                | uint32    | Initiates a String data block containing the name of the interface. This value is always 0.  |
| String Block Length              | uint32    | The number of bytes included in the interface name String data block, including eight bytes for the block type and header fields plus the number of bytes in the interface name. |
| Interface Name                   | string    | The interface name.  |

## Access Control Policy Name Record

The eStreamer service transmits metadata on the name of the access control policy that triggered an intrusion event or connection event within an Access Control Policy Name record, the format of which is shown below. (Access control policy name information is sent when the Version 4 metadata flag—bit 20 in the Request Flags field of a request message—is set. See [Request Flags, page 2-11](#).) Note that the Record Type field, which appears after the Message Length field, has a value of 117, indicating an Access Control Policy Name record. It contains a UUID String data block, block type 14 in the series 2 set of data blocks.

|                    |   |   |   |   |   |   |   |   |   |   |    |    |    |    |    |                  |    |    |    |    |    |    |    |    |    |    |    |    |    |    |    |    |
|--------------------|---|---|---|---|---|---|---|---|---|---|----|----|----|----|----|------------------|----|----|----|----|----|----|----|----|----|----|----|----|----|----|----|----|
| Byte               | 0 |   |   |   |   |   |   |   | 1 |   |    |    |    |    |    |                  | 2  |    |    |    |    |    |    |    | 3  |    |    |    |    |    |    |    |
| Bit                | 0 | 1 | 2 | 3 | 4 | 5 | 6 | 7 | 8 | 9 | 10 | 11 | 12 | 13 | 14 | 15               | 16 | 17 | 18 | 19 | 20 | 21 | 22 | 23 | 24 | 25 | 26 | 27 | 28 | 29 | 30 | 31 |
| Header Version (1) |   |   |   |   |   |   |   |   |   |   |    |    |    |    |    | Message Type (4) |    |    |    |    |    |    |    |    |    |    |    |    |    |    |    |    |
| Message Length     |   |   |   |   |   |   |   |   |   |   |    |    |    |    |    |                  |    |    |    |    |    |    |    |    |    |    |    |    |    |    |    |    |
| Record Type (117)  |   |   |   |   |   |   |   |   |   |   |    |    |    |    |    |                  |    |    |    |    |    |    |    |    |    |    |    |    |    |    |    |    |
| Record Length      |   |   |   |   |   |   |   |   |   |   |    |    |    |    |    |                  |    |    |    |    |    |    |    |    |    |    |    |    |    |    |    |    |

| Byte   | 0 |   |   |   |   |   |   |   | 1 |   |    |    |    |    |    |    | 2  |    |    |    |    |    |    |    | 3  |    |    |    |    |    |    |    |
|--|---|---|---|---|---|---|---|---|---|---|----|----|----|----|----|----|----|----|----|----|----|----|----|----|----|----|----|----|----|----|----|----|
| Bit  | 0 | 1 | 2 | 3 | 4 | 5 | 6 | 7 | 8 | 9 | 10 | 11 | 12 | 13 | 14 | 15 | 16 | 17 | 18 | 19 | 20 | 21 | 22 | 23 | 24 | 25 | 26 | 27 | 28 | 29 | 30 | 31 |
| Access Control Policy Name Data Block (14)   |   |   |   |   |   |   |   |   |   |   |    |    |    |    |    |    |    |    |    |    |    |    |    |    |    |    |    |    |    |    |    |    |
| Access Control Policy Name Data Block Length |   |   |   |   |   |   |   |   |   |   |    |    |    |    |    |    |    |    |    |    |    |    |    |    |    |    |    |    |    |    |    |    |
| Access Control Policy UUID                   |   |   |   |   |   |   |   |   |   |   |    |    |    |    |    |    |    |    |    |    |    |    |    |    |    |    |    |    |    |    |    |    |
| String Block Type (0)                        |   |   |   |   |   |   |   |   |   |   |    |    |    |    |    |    |    |    |    |    |    |    |    |    |    |    |    |    |    |    |    |    |
| String Block Length                          |   |   |   |   |   |   |   |   |   |   |    |    |    |    |    |    |    |    |    |    |    |    |    |    |    |    |    |    |    |    |    |    |
| Access Control Policy Name...                |   |   |   |   |   |   |   |   |   |   |    |    |    |    |    |    |    |    |    |    |    |    |    |    |    |    |    |    |    |    |    |    |

The following table describes the fields in the Access Control Policy Name data block.

**Table 3-15** Access Control Policy Name Data Block Fields

| Field  | Data Type | Description  |
|--|-----------|--|
| Access Control Policy Name Data Block Type   | uint32    | Initiates an Access Control Policy Name data block. This value is always 14. The block type is a series 2 block.   |
| Access Control Policy Name Data Block Length | uint32    | Length of the data block. Includes the number of bytes of data plus the 8 bytes in the two data block header fields.   |
| Access Control Policy UUID                   | uint8[16] | An ID number that acts as a unique identifier for the access control policy associated with the intrusion event or connection event  |
| String Block Type                            | uint32    | Initiates a String data block containing the name of the access control policy. This value is always 0.  |
| String Block Length                          | uint32    | The number of bytes included in the access control policy name String data block, including eight bytes for the block type and header fields plus the number of bytes in the access control policy name. |
| Access Control Policy Name                   | string    | The access control policy name.  |

## Access Control Rule ID Record Metadata

The eStreamer service transmits metadata containing information about the access control rule that triggered an intrusion event or connection event within an Access Control Rule ID record, the format of which is shown below. Access control rule metadata is sent when the Version 4 metadata flag—bit 20 in the Request Flags field of a request message—is set. See [Request Flags, page 2-11](#).) Note that the Record Type field, which appears after the Message Length field, has a value of 119, indicating an Access Control Rule ID record. It contains a Rule ID data block, block type 15 in the series 2 set of data blocks.

| Byte | 0  |   |   |   |   |   |   |   | 1 |   |    |    |    |    |    |    | 2                |    |    |    |    |    |    |    | 3  |    |    |    |    |    |    |    |
|------|--|---|---|---|---|---|---|---|---|---|----|----|----|----|----|----|------------------|----|----|----|----|----|----|----|----|----|----|----|----|----|----|----|
| Bit  | 0  | 1 | 2 | 3 | 4 | 5 | 6 | 7 | 8 | 9 | 10 | 11 | 12 | 13 | 14 | 15 | 16               | 17 | 18 | 19 | 20 | 21 | 22 | 23 | 24 | 25 | 26 | 27 | 28 | 29 | 30 | 31 |
|      | Header Version (1)                       |   |   |   |   |   |   |   |   |   |    |    |    |    |    |    | Message Type (4) |    |    |    |    |    |    |    |    |    |    |    |    |    |    |    |
|      | Message Length                           |   |   |   |   |   |   |   |   |   |    |    |    |    |    |    |                  |    |    |    |    |    |    |    |    |    |    |    |    |    |    |    |
|      | Record Type (119)                        |   |   |   |   |   |   |   |   |   |    |    |    |    |    |    |                  |    |    |    |    |    |    |    |    |    |    |    |    |    |    |    |
|      | Record Length                            |   |   |   |   |   |   |   |   |   |    |    |    |    |    |    |                  |    |    |    |    |    |    |    |    |    |    |    |    |    |    |    |
|      | Access Control Rule ID Data Block (15)   |   |   |   |   |   |   |   |   |   |    |    |    |    |    |    |                  |    |    |    |    |    |    |    |    |    |    |    |    |    |    |    |
|      | Access Control Rule ID Data Block Length |   |   |   |   |   |   |   |   |   |    |    |    |    |    |    |                  |    |    |    |    |    |    |    |    |    |    |    |    |    |    |    |
|      | Access Control Rule UUID                 |   |   |   |   |   |   |   |   |   |    |    |    |    |    |    |                  |    |    |    |    |    |    |    |    |    |    |    |    |    |    |    |
|      | Access Control Rule ID                   |   |   |   |   |   |   |   |   |   |    |    |    |    |    |    |                  |    |    |    |    |    |    |    |    |    |    |    |    |    |    |    |
|      | String Block Type (0)                    |   |   |   |   |   |   |   |   |   |    |    |    |    |    |    |                  |    |    |    |    |    |    |    |    |    |    |    |    |    |    |    |
|      | String Block Length                      |   |   |   |   |   |   |   |   |   |    |    |    |    |    |    |                  |    |    |    |    |    |    |    |    |    |    |    |    |    |    |    |
|      | Access Control Rule Name...              |   |   |   |   |   |   |   |   |   |    |    |    |    |    |    |                  |    |    |    |    |    |    |    |    |    |    |    |    |    |    |    |

The following table describes the fields in the Access Control Rule ID data block.

**Table 3-16** Access Control Rule ID Data Block Fields

| Field                                    | Data Type | Description  |
|--|-----------|--|
| Access Control Rule ID Data Block Type   | uint32    | Initiates an Access Control Rule ID data block. This value is always 15. The block type is a series 2 block.   |
| Access Control Rule ID Data Block Length | uint32    | Length of the data block. Includes the number of bytes of data plus the 8 bytes in the two data block header fields.   |
| Access Control Rule UUID                 | uint8[16] | A rule ID that acts as the unique identifier for the rule in the access control policy associated with the connection event.                                 |
| Access Control Rule ID                   | uint32    | The internal identifier for the rule in the access control policy associated with the connection event.  |
| String Block Type                        | uint32    | Initiates a String data block containing the name of the access control rule. This value is always 0.  |
| String Block Length                      | uint32    | The number of bytes included in the String data block, including eight bytes for the block type and header fields plus the number of bytes in the rule name. |
| Access Control Rule Name                 | string    | The access control rule name.  |

## Managed Device Record Metadata

The eStreamer service transmits metadata containing information on the managed device associated with an intrusion event within a Managed Device record, the format of which is shown below. Managed device metadata is sent when the Version 4 metadata flag—bit 20 in the Request Flags field of a request message—is set. See [Request Flags, page 2-11](#).) Note that the Record Type field, which appears after the Message Length field, has a value of 123, indicating a Managed Device record.

|      |                    |   |   |   |   |   |   |   |   |   |    |    |    |    |    |    |                  |    |    |    |    |    |    |    |    |    |    |    |    |    |    |    |
|------|--------------------|---|---|---|---|---|---|---|---|---|----|----|----|----|----|----|------------------|----|----|----|----|----|----|----|----|----|----|----|----|----|----|----|
| Byte | 0                  |   |   |   |   |   |   |   | 1 |   |    |    |    |    |    |    | 2                |    |    |    |    |    |    |    | 3  |    |    |    |    |    |    |    |
| Bit  | 0                  | 1 | 2 | 3 | 4 | 5 | 6 | 7 | 8 | 9 | 10 | 11 | 12 | 13 | 14 | 15 | 16               | 17 | 18 | 19 | 20 | 21 | 22 | 23 | 24 | 25 | 26 | 27 | 28 | 29 | 30 | 31 |
|      | Header Version (1) |   |   |   |   |   |   |   |   |   |    |    |    |    |    |    | Message Type (4) |    |    |    |    |    |    |    |    |    |    |    |    |    |    |    |
|      | Message Length     |   |   |   |   |   |   |   |   |   |    |    |    |    |    |    |                  |    |    |    |    |    |    |    |    |    |    |    |    |    |    |    |
|      | Record Type (123)  |   |   |   |   |   |   |   |   |   |    |    |    |    |    |    |                  |    |    |    |    |    |    |    |    |    |    |    |    |    |    |    |
|      | Record Length      |   |   |   |   |   |   |   |   |   |    |    |    |    |    |    |                  |    |    |    |    |    |    |    |    |    |    |    |    |    |    |    |
|      | Device ID          |   |   |   |   |   |   |   |   |   |    |    |    |    |    |    |                  |    |    |    |    |    |    |    |    |    |    |    |    |    |    |    |
|      | Name Length        |   |   |   |   |   |   |   |   |   |    |    |    |    |    |    |                  |    |    |    |    |    |    |    |    |    |    |    |    |    |    |    |
|      | Name...            |   |   |   |   |   |   |   |   |   |    |    |    |    |    |    |                  |    |    |    |    |    |    |    |    |    |    |    |    |    |    |    |

The following table describes the fields in the Managed Device record.

*Table 3-17 Managed Device Record Fields*

| Field       | Data Type | Description                               |
|-------------|-----------|---|
| Device ID   | uint32    | ID number of the managed device.          |
| Name Length | uint32    | The number of bytes included in the name. |
| Name        | string    | The managed device name.                  |

## Malware Event Record 5.1.1+

The fields in the malware event record are shaded in the following graphic. The record type is 125.

You request malware event records by setting the malware event flag—bit 30 in the Request Flags field—in the request message with an event version of 2 and an event code of 101. See [Request Flags, page 2-11](#). If you enable bit 23, an extended event header is included in the record. It contains a Malware Event data block, one of block types 24, 33, 35, 44, or 47 in the series 2 set of data blocks.

|      |   |   |   |   |   |   |   |   |   |   |    |    |    |    |    |    |                  |    |    |    |    |    |    |    |    |    |    |    |    |    |    |    |
|------|---|---|---|---|---|---|---|---|---|---|----|----|----|----|----|----|------------------|----|----|----|----|----|----|----|----|----|----|----|----|----|----|----|
| Byte | 0   |   |   |   |   |   |   |   | 1 |   |    |    |    |    |    |    | 2                |    |    |    |    |    |    |    | 3  |    |    |    |    |    |    |    |
| Bit  | 0   | 1 | 2 | 3 | 4 | 5 | 6 | 7 | 8 | 9 | 10 | 11 | 12 | 13 | 14 | 15 | 16               | 17 | 18 | 19 | 20 | 21 | 22 | 23 | 24 | 25 | 26 | 27 | 28 | 29 | 30 | 31 |
|      | Header Version (1)  |   |   |   |   |   |   |   |   |   |    |    |    |    |    |    | Message Type (4) |    |    |    |    |    |    |    |    |    |    |    |    |    |    |    |
|      | Message Length  |   |   |   |   |   |   |   |   |   |    |    |    |    |    |    |                  |    |    |    |    |    |    |    |    |    |    |    |    |    |    |    |
|      | Record Type (125)   |   |   |   |   |   |   |   |   |   |    |    |    |    |    |    |                  |    |    |    |    |    |    |    |    |    |    |    |    |    |    |    |
|      | Record Length   |   |   |   |   |   |   |   |   |   |    |    |    |    |    |    |                  |    |    |    |    |    |    |    |    |    |    |    |    |    |    |    |
|      | eStreamer Server Timestamp (in events, only if bit 23 is set) |   |   |   |   |   |   |   |   |   |    |    |    |    |    |    |                  |    |    |    |    |    |    |    |    |    |    |    |    |    |    |    |
|      | Reserved for Future Use (in events, only if bit 23 is set)    |   |   |   |   |   |   |   |   |   |    |    |    |    |    |    |                  |    |    |    |    |    |    |    |    |    |    |    |    |    |    |    |
|      | Malware Event Data Block                                      |   |   |   |   |   |   |   |   |   |    |    |    |    |    |    |                  |    |    |    |    |    |    |    |    |    |    |    |    |    |    |    |

The following table describes each malware event record data field.

**Table 3-18** Malware Event Record Fields

| Field                    | Data Type | Description   |
|--------------------------|-----------|---|
| Malware Event Data Block | variable  | Indicates a malware event data block. See <a href="#">Malware Event Data Block 5.3.1+</a> , page 3-64 for more information. |

## Collective Security Intelligence Cloud Name Metadata

The eStreamer service transmits metadata containing information on the name of the Collective Security Intelligence Cloud (referred to as the Cisco cloud or simply cloud) associated with an intrusion event or connection event within a Collective Security Intelligence Cloud Name record, the format of which is shown below. (Cisco cloud name information is sent when the Version 4 metadata flag—bit 20 in the Request Flags field of a request message—is set. See [Request Flags](#), page 2-11.) Note that the Record Type field, which appears after the Message Length field, has a value of 127, indicating a Collective Security Intelligence Cloud Name record. It contains a UUID String data block, block type 14 in the series 2 set of data blocks.

|      |                    |   |   |   |   |   |   |   |   |   |    |    |    |    |    |    |                  |    |    |    |    |    |    |    |    |    |    |    |    |    |    |    |
|------|--------------------|---|---|---|---|---|---|---|---|---|----|----|----|----|----|----|------------------|----|----|----|----|----|----|----|----|----|----|----|----|----|----|----|
| Byte | 0                  |   |   |   |   |   |   |   | 1 |   |    |    |    |    |    |    | 2                |    |    |    |    |    |    |    | 3  |    |    |    |    |    |    |    |
| Bit  | 0                  | 1 | 2 | 3 | 4 | 5 | 6 | 7 | 8 | 9 | 10 | 11 | 12 | 13 | 14 | 15 | 16               | 17 | 18 | 19 | 20 | 21 | 22 | 23 | 24 | 25 | 26 | 27 | 28 | 29 | 30 | 31 |
|      | Header Version (1) |   |   |   |   |   |   |   |   |   |    |    |    |    |    |    | Message Type (4) |    |    |    |    |    |    |    |    |    |    |    |    |    |    |    |
|      | Message Length     |   |   |   |   |   |   |   |   |   |    |    |    |    |    |    |                  |    |    |    |    |    |    |    |    |    |    |    |    |    |    |    |
|      | Record Type (127)  |   |   |   |   |   |   |   |   |   |    |    |    |    |    |    |                  |    |    |    |    |    |    |    |    |    |    |    |    |    |    |    |
|      | Record Length      |   |   |   |   |   |   |   |   |   |    |    |    |    |    |    |                  |    |    |    |    |    |    |    |    |    |    |    |    |    |    |    |

| Byte  | 0 |   |   |   |   |   |   |   | 1 |   |    |    |    |    |    |    | 2  |    |    |    |    |    |    |    | 3  |    |    |    |    |    |    |    |
|---|---|---|---|---|---|---|---|---|---|---|----|----|----|----|----|----|----|----|----|----|----|----|----|----|----|----|----|----|----|----|----|----|
| Bit   | 0 | 1 | 2 | 3 | 4 | 5 | 6 | 7 | 8 | 9 | 10 | 11 | 12 | 13 | 14 | 15 | 16 | 17 | 18 | 19 | 20 | 21 | 22 | 23 | 24 | 25 | 26 | 27 | 28 | 29 | 30 | 31 |
| Collective Security Intelligence Cloud Name Data Block (14)   |   |   |   |   |   |   |   |   |   |   |    |    |    |    |    |    |    |    |    |    |    |    |    |    |    |    |    |    |    |    |    |    |
| Collective Security Intelligence Cloud Name Data Block Length |   |   |   |   |   |   |   |   |   |   |    |    |    |    |    |    |    |    |    |    |    |    |    |    |    |    |    |    |    |    |    |    |
| Collective Security Intelligence Cloud UUID                   |   |   |   |   |   |   |   |   |   |   |    |    |    |    |    |    |    |    |    |    |    |    |    |    |    |    |    |    |    |    |    |    |
| Collective Security Intelligence Cloud UUID, cont.            |   |   |   |   |   |   |   |   |   |   |    |    |    |    |    |    |    |    |    |    |    |    |    |    |    |    |    |    |    |    |    |    |
| Collective Security Intelligence Cloud UUID, cont.            |   |   |   |   |   |   |   |   |   |   |    |    |    |    |    |    |    |    |    |    |    |    |    |    |    |    |    |    |    |    |    |    |
| Collective Security Intelligence Cloud UUID, cont.            |   |   |   |   |   |   |   |   |   |   |    |    |    |    |    |    |    |    |    |    |    |    |    |    |    |    |    |    |    |    |    |    |
| String Block Type (0)   |   |   |   |   |   |   |   |   |   |   |    |    |    |    |    |    |    |    |    |    |    |    |    |    |    |    |    |    |    |    |    |    |
| String Block Length   |   |   |   |   |   |   |   |   |   |   |    |    |    |    |    |    |    |    |    |    |    |    |    |    |    |    |    |    |    |    |    |    |
| Collective Security Intelligence Cloud Name...                |   |   |   |   |   |   |   |   |   |   |    |    |    |    |    |    |    |    |    |    |    |    |    |    |    |    |    |    |    |    |    |    |

The following table describes the fields in the Collective Security Intelligence Cloud Name data block.

**Table 3-19** *Collective Security Intelligence Cloud Name Data Block Fields*

| Field   | Data Type | Description  |
|---|-----------|--|
| Collective Security Intelligence Cloud Name Data Block Type   | uint32    | Initiates a Collective Security Intelligence Cloud Name data block. This value is always 14. The block type is a series 2 block.   |
| Collective Security Intelligence Cloud Name Data Block Length | uint32    | Length of the data block. Includes the number of bytes of data plus the 8 bytes in the two data block header fields.   |
| Collective Security Intelligence Cloud UUID                   | uint8[16] | A Collective Security Intelligence Cloud ID number that acts as a unique identifier for the Collective Security Intelligence Cloud associated with the connection event. |
| String Block Type   | uint32    | Initiates a String data block containing the name of the Collective Security Intelligence Cloud. This value is always 0.   |

Table 3-19 Collective Security Intelligence Cloud Name Data Block Fields (continued)

| Field                                       | Data Type | Description  |
|---|-----------|--|
| String Block Length                         | uint32    | The number of bytes included in the Collective Security Intelligence Cloud Name String data block, including eight bytes for the block type and header fields plus the number of bytes in the Collective Security Intelligence Cloud name. |
| Collective Security Intelligence Cloud Name | string    | The Collective Security Intelligence Cloud name.   |

## Malware Event Type Metadata

The eStreamer service transmits metadata containing malware event type information for an event within a malware event type record, the format of which is shown below. (Malware event type information is sent when the metadata flag, bit 20 in the request flags field of a request message, is set. See [Request Flags, page 2-11](#).) Note that the record type field, which appears after the message length field, has a value of 128, indicating a malware event type record.

| Byte | 0                         |   |   |   |   |   |   |   | 1 |   |    |    |    |    |    |    | 2                |    |    |    |    |    |    |    | 3  |    |    |    |    |    |    |    |
|------|---------------------------|---|---|---|---|---|---|---|---|---|----|----|----|----|----|----|------------------|----|----|----|----|----|----|----|----|----|----|----|----|----|----|----|
| Bit  | 0                         | 1 | 2 | 3 | 4 | 5 | 6 | 7 | 8 | 9 | 10 | 11 | 12 | 13 | 14 | 15 | 16               | 17 | 18 | 19 | 20 | 21 | 22 | 23 | 24 | 25 | 26 | 27 | 28 | 29 | 30 | 31 |
|      | Header Version (1)        |   |   |   |   |   |   |   |   |   |    |    |    |    |    |    | Message Type (4) |    |    |    |    |    |    |    |    |    |    |    |    |    |    |    |
|      | Message Length            |   |   |   |   |   |   |   |   |   |    |    |    |    |    |    |                  |    |    |    |    |    |    |    |    |    |    |    |    |    |    |    |
|      | Record Type (128)         |   |   |   |   |   |   |   |   |   |    |    |    |    |    |    |                  |    |    |    |    |    |    |    |    |    |    |    |    |    |    |    |
|      | Record Length             |   |   |   |   |   |   |   |   |   |    |    |    |    |    |    |                  |    |    |    |    |    |    |    |    |    |    |    |    |    |    |    |
|      | Malware Event Type ID     |   |   |   |   |   |   |   |   |   |    |    |    |    |    |    |                  |    |    |    |    |    |    |    |    |    |    |    |    |    |    |    |
|      | Malware Event Type Length |   |   |   |   |   |   |   |   |   |    |    |    |    |    |    |                  |    |    |    |    |    |    |    |    |    |    |    |    |    |    |    |
|      | Malware Event Type...     |   |   |   |   |   |   |   |   |   |    |    |    |    |    |    |                  |    |    |    |    |    |    |    |    |    |    |    |    |    |    |    |

The following table describes the fields in the malware event type record.

Table 3-20 Malware Event Type Record Fields

| Field                     | Data Type | Description   |
|---------------------------|-----------|---|
| Malware Event Type ID     | uint32    | The malware event type ID number.                       |
| Malware Event Type Length | uint32    | The number of bytes included in the malware event type. |
| Malware Event Type        | string    | The type of malware event.                              |

## Malware Event Subtype Metadata

The eStreamer service transmits metadata containing malware event subtype information for an event within a malware event subtype record, the format of which is shown below. (Malware event type information is sent when the metadata flag, bit 20 in the request flags field of a request message, is set. See [Request Flags, page 2-11](#).) Note that the record type field, which appears after the message length field, has a value of 129, indicating a malware event subtype record.

|      |                              |   |   |   |   |   |   |   |   |   |    |    |    |    |    |    |                  |    |    |    |    |    |    |    |    |    |    |    |    |    |    |    |
|------|------------------------------|---|---|---|---|---|---|---|---|---|----|----|----|----|----|----|------------------|----|----|----|----|----|----|----|----|----|----|----|----|----|----|----|
| Byte | 0                            |   |   |   |   |   |   |   | 1 |   |    |    |    |    |    |    | 2                |    |    |    |    |    |    |    | 3  |    |    |    |    |    |    |    |
| Bit  | 0                            | 1 | 2 | 3 | 4 | 5 | 6 | 7 | 8 | 9 | 10 | 11 | 12 | 13 | 14 | 15 | 16               | 17 | 18 | 19 | 20 | 21 | 22 | 23 | 24 | 25 | 26 | 27 | 28 | 29 | 30 | 31 |
|      | Header Version (1)           |   |   |   |   |   |   |   |   |   |    |    |    |    |    |    | Message Type (4) |    |    |    |    |    |    |    |    |    |    |    |    |    |    |    |
|      | Message Length               |   |   |   |   |   |   |   |   |   |    |    |    |    |    |    |                  |    |    |    |    |    |    |    |    |    |    |    |    |    |    |    |
|      | Record Type (129)            |   |   |   |   |   |   |   |   |   |    |    |    |    |    |    |                  |    |    |    |    |    |    |    |    |    |    |    |    |    |    |    |
|      | Record Length                |   |   |   |   |   |   |   |   |   |    |    |    |    |    |    |                  |    |    |    |    |    |    |    |    |    |    |    |    |    |    |    |
|      | Malware Event Subtype ID     |   |   |   |   |   |   |   |   |   |    |    |    |    |    |    |                  |    |    |    |    |    |    |    |    |    |    |    |    |    |    |    |
|      | Malware Event Subtype Length |   |   |   |   |   |   |   |   |   |    |    |    |    |    |    |                  |    |    |    |    |    |    |    |    |    |    |    |    |    |    |    |
|      | Malware Event Subtype...     |   |   |   |   |   |   |   |   |   |    |    |    |    |    |    |                  |    |    |    |    |    |    |    |    |    |    |    |    |    |    |    |

The following table describes the fields in the malware event subtype record.

*Table 3-21 Malware Event Subtype Record Fields*

| Field                        | Data Type | Description  |
|------------------------------|-----------|--|
| Malware Event Subtype ID     | uint32    | The malware event subtype ID number.                       |
| Malware Event Subtype Length | uint32    | The number of bytes included in the malware event subtype. |
| Malware Event Subtype        | string    | The malware event subtype.                                 |

## FireAMP Detector Type Metadata

The eStreamer service transmits metadata containing FireAMP detector type information for an event within a FireAMP Detector Type record, the format of which is shown below. (FireAMP detector type information is sent when one of the metadata flags—bits 1, 14, 15, or 20 in the Request Flags field of a request message—is set. See [Request Flags, page 2-11](#).) Note that the Record Type field, which appears after the Message Length field, has a value of 130, indicating a FireAMP detector type record.



|      |                              |   |   |   |   |   |   |   |   |   |    |    |    |    |    |    |                  |    |    |    |    |    |    |    |    |    |    |    |    |    |    |    |
|------|------------------------------|---|---|---|---|---|---|---|---|---|----|----|----|----|----|----|------------------|----|----|----|----|----|----|----|----|----|----|----|----|----|----|----|
| Byte | 0                            |   |   |   |   |   |   |   | 1 |   |    |    |    |    |    |    | 2                |    |    |    |    |    |    |    | 3  |    |    |    |    |    |    |    |
| Bit  | 0                            | 1 | 2 | 3 | 4 | 5 | 6 | 7 | 8 | 9 | 10 | 11 | 12 | 13 | 14 | 15 | 16               | 17 | 18 | 19 | 20 | 21 | 22 | 23 | 24 | 25 | 26 | 27 | 28 | 29 | 30 | 31 |
|      | Header Version (1)           |   |   |   |   |   |   |   |   |   |    |    |    |    |    |    | Message Type (4) |    |    |    |    |    |    |    |    |    |    |    |    |    |    |    |
|      | Message Length               |   |   |   |   |   |   |   |   |   |    |    |    |    |    |    |                  |    |    |    |    |    |    |    |    |    |    |    |    |    |    |    |
|      | Record Type (130)            |   |   |   |   |   |   |   |   |   |    |    |    |    |    |    |                  |    |    |    |    |    |    |    |    |    |    |    |    |    |    |    |
|      | Record Length                |   |   |   |   |   |   |   |   |   |    |    |    |    |    |    |                  |    |    |    |    |    |    |    |    |    |    |    |    |    |    |    |
|      | FireAMP Detector Type ID     |   |   |   |   |   |   |   |   |   |    |    |    |    |    |    |                  |    |    |    |    |    |    |    |    |    |    |    |    |    |    |    |
|      | FireAMP Detector Type Length |   |   |   |   |   |   |   |   |   |    |    |    |    |    |    |                  |    |    |    |    |    |    |    |    |    |    |    |    |    |    |    |
|      | FireAMP Detector Type...     |   |   |   |   |   |   |   |   |   |    |    |    |    |    |    |                  |    |    |    |    |    |    |    |    |    |    |    |    |    |    |    |

The following table describes the fields in the FireAMP Detector Type record.

*Table 3-22 FireAMP Detector Type Record Fields*

| Field                        | Data Type | Description  |
|------------------------------|-----------|--|
| FireAMP Detector Type ID     | uint32    | The FireAMP detector type ID number.                       |
| FireAMP Detector Type Length | uint32    | The number of bytes included in the FireAMP detector type. |
| FireAMP Detector Type        | string    | The type of FireAMP detector.                              |

## FireAMP File Type Metadata

The eStreamer service transmits metadata containing FireAMP file type information for an event within a FireAMP File Type record, the format of which is shown below. (FireAMP file type information is sent when one of the metadata flags—bits 1, 14, 15, or 20 in the Request Flags field of a request message—is set. See [Request Flags, page 2-11](#).) Note that the Record Type field, which appears after the Message Length field, has a value of 131, indicating a FireAMP file type record.

|      |                    |   |   |   |   |   |   |   |   |   |    |    |    |    |    |    |                  |    |    |    |    |    |    |    |    |    |    |    |    |    |    |    |
|------|--------------------|---|---|---|---|---|---|---|---|---|----|----|----|----|----|----|------------------|----|----|----|----|----|----|----|----|----|----|----|----|----|----|----|
| Byte | 0                  |   |   |   |   |   |   |   | 1 |   |    |    |    |    |    |    | 2                |    |    |    |    |    |    |    | 3  |    |    |    |    |    |    |    |
| Bit  | 0                  | 1 | 2 | 3 | 4 | 5 | 6 | 7 | 8 | 9 | 10 | 11 | 12 | 13 | 14 | 15 | 16               | 17 | 18 | 19 | 20 | 21 | 22 | 23 | 24 | 25 | 26 | 27 | 28 | 29 | 30 | 31 |
|      | Header Version (1) |   |   |   |   |   |   |   |   |   |    |    |    |    |    |    | Message Type (4) |    |    |    |    |    |    |    |    |    |    |    |    |    |    |    |
|      | Message Length     |   |   |   |   |   |   |   |   |   |    |    |    |    |    |    |                  |    |    |    |    |    |    |    |    |    |    |    |    |    |    |    |
|      | Record Type (131)  |   |   |   |   |   |   |   |   |   |    |    |    |    |    |    |                  |    |    |    |    |    |    |    |    |    |    |    |    |    |    |    |
|      | Record Length      |   |   |   |   |   |   |   |   |   |    |    |    |    |    |    |                  |    |    |    |    |    |    |    |    |    |    |    |    |    |    |    |

|                          |   |   |   |   |   |   |   |   |   |   |    |    |    |    |    |    |    |    |    |    |    |    |    |    |    |    |    |    |    |    |    |    |
|--------------------------|---|---|---|---|---|---|---|---|---|---|----|----|----|----|----|----|----|----|----|----|----|----|----|----|----|----|----|----|----|----|----|----|
| Byte                     | 0 |   |   |   |   |   |   |   | 1 |   |    |    |    |    |    |    | 2  |    |    |    |    |    |    |    | 3  |    |    |    |    |    |    |    |
| Bit                      | 0 | 1 | 2 | 3 | 4 | 5 | 6 | 7 | 8 | 9 | 10 | 11 | 12 | 13 | 14 | 15 | 16 | 17 | 18 | 19 | 20 | 21 | 22 | 23 | 24 | 25 | 26 | 27 | 28 | 29 | 30 | 31 |
| FireAMP File Type ID     |   |   |   |   |   |   |   |   |   |   |    |    |    |    |    |    |    |    |    |    |    |    |    |    |    |    |    |    |    |    |    |    |
| FireAMP File Type Length |   |   |   |   |   |   |   |   |   |   |    |    |    |    |    |    |    |    |    |    |    |    |    |    |    |    |    |    |    |    |    |    |
| FireAMP File Type...     |   |   |   |   |   |   |   |   |   |   |    |    |    |    |    |    |    |    |    |    |    |    |    |    |    |    |    |    |    |    |    |    |

The following table describes the fields in the FireAMP File Type record.

**Table 3-23** FireAMP File Type Record Fields

| Field                    | Data Type | Description  |
|--------------------------|-----------|--|
| FireAMP File Type ID     | uint32    | The FireAMP file type ID number.                       |
| FireAMP File Type Length | uint32    | The number of bytes included in the FireAMP file type. |
| FireAMP File Type        | string    | The type of detected file.                             |

## Correlation Event for 5.1+

Correlation events (called compliance events in pre-5.0 versions) contain information about correlation policy violations. This message uses the standard eStreamer message header and specifies a record type of 112, followed by a correlation data block of type 128 in the series 1 set of data blocks. Data block type 128 differs from its predecessor (block type 116) in including IPv6 support.

You can request 5.1+ correlation events from eStreamer only by extended request, for which you request event type code 31 and version code 8 in the Stream Request message (see [Submitting Extended Requests, page 2-4](#) for information about submitting extended requests). You can optionally enable bit 23 in the flags field of the initial event stream request message, to include the extended event header. You can also enable bit 20 in the flags field to include user metadata.

|   |   |   |   |   |   |   |   |   |   |   |    |    |    |    |    |                  |    |    |    |    |    |    |    |    |    |    |    |    |    |    |    |    |
|---|---|---|---|---|---|---|---|---|---|---|----|----|----|----|----|------------------|----|----|----|----|----|----|----|----|----|----|----|----|----|----|----|----|
| Byte  | 0 |   |   |   |   |   |   |   | 1 |   |    |    |    |    |    |                  | 2  |    |    |    |    |    |    |    | 3  |    |    |    |    |    |    |    |
| Bit   | 0 | 1 | 2 | 3 | 4 | 5 | 6 | 7 | 8 | 9 | 10 | 11 | 12 | 13 | 14 | 15               | 16 | 17 | 18 | 19 | 20 | 21 | 22 | 23 | 24 | 25 | 26 | 27 | 28 | 29 | 30 | 31 |
| Header Version (1)  |   |   |   |   |   |   |   |   |   |   |    |    |    |    |    | Message Type (4) |    |    |    |    |    |    |    |    |    |    |    |    |    |    |    |    |
| Message Length  |   |   |   |   |   |   |   |   |   |   |    |    |    |    |    |                  |    |    |    |    |    |    |    |    |    |    |    |    |    |    |    |    |
| Record Type (112)   |   |   |   |   |   |   |   |   |   |   |    |    |    |    |    |                  |    |    |    |    |    |    |    |    |    |    |    |    |    |    |    |    |
| Record Length   |   |   |   |   |   |   |   |   |   |   |    |    |    |    |    |                  |    |    |    |    |    |    |    |    |    |    |    |    |    |    |    |    |
| eStreamer Server Timestamp (in events, only if bit 23 is set) |   |   |   |   |   |   |   |   |   |   |    |    |    |    |    |                  |    |    |    |    |    |    |    |    |    |    |    |    |    |    |    |    |
| Reserved for Future Use (in events, only if bit 23 is set)    |   |   |   |   |   |   |   |   |   |   |    |    |    |    |    |                  |    |    |    |    |    |    |    |    |    |    |    |    |    |    |    |    |
| Correlation Block Type (128)                                  |   |   |   |   |   |   |   |   |   |   |    |    |    |    |    |                  |    |    |    |    |    |    |    |    |    |    |    |    |    |    |    |    |

| Byte                | 0                                     |   |   |   |   |   |   |   | 1              |   |    |    |    |    |    |    | 2                |    |    |    |    |    |    |    | 3                   |    |    |    |    |    |    |    |
|---------------------|---------------------------------------|---|---|---|---|---|---|---|----------------|---|----|----|----|----|----|----|------------------|----|----|----|----|----|----|----|---------------------|----|----|----|----|----|----|----|
| Bit                 | 0                                     | 1 | 2 | 3 | 4 | 5 | 6 | 7 | 8              | 9 | 10 | 11 | 12 | 13 | 14 | 15 | 16               | 17 | 18 | 19 | 20 | 21 | 22 | 23 | 24                  | 25 | 26 | 27 | 28 | 29 | 30 | 31 |
|                     | Correlation Block Length              |   |   |   |   |   |   |   |                |   |    |    |    |    |    |    |                  |    |    |    |    |    |    |    |                     |    |    |    |    |    |    |    |
|                     | Device ID                             |   |   |   |   |   |   |   |                |   |    |    |    |    |    |    |                  |    |    |    |    |    |    |    |                     |    |    |    |    |    |    |    |
|                     | (Correlation) Event Second            |   |   |   |   |   |   |   |                |   |    |    |    |    |    |    |                  |    |    |    |    |    |    |    |                     |    |    |    |    |    |    |    |
|                     | Event ID                              |   |   |   |   |   |   |   |                |   |    |    |    |    |    |    |                  |    |    |    |    |    |    |    |                     |    |    |    |    |    |    |    |
|                     | Policy ID                             |   |   |   |   |   |   |   |                |   |    |    |    |    |    |    |                  |    |    |    |    |    |    |    |                     |    |    |    |    |    |    |    |
|                     | Rule ID                               |   |   |   |   |   |   |   |                |   |    |    |    |    |    |    |                  |    |    |    |    |    |    |    |                     |    |    |    |    |    |    |    |
|                     | Priority                              |   |   |   |   |   |   |   |                |   |    |    |    |    |    |    |                  |    |    |    |    |    |    |    |                     |    |    |    |    |    |    |    |
| Event Description   | String Block Type (0)                 |   |   |   |   |   |   |   |                |   |    |    |    |    |    |    |                  |    |    |    |    |    |    |    |                     |    |    |    |    |    |    |    |
|                     | String Block Length                   |   |   |   |   |   |   |   |                |   |    |    |    |    |    |    |                  |    |    |    |    |    |    |    |                     |    |    |    |    |    |    |    |
|                     | Description...                        |   |   |   |   |   |   |   |                |   |    |    |    |    |    |    |                  |    |    |    |    |    |    |    | Event Type          |    |    |    |    |    |    |    |
|                     | Event Device ID                       |   |   |   |   |   |   |   |                |   |    |    |    |    |    |    |                  |    |    |    |    |    |    |    |                     |    |    |    |    |    |    |    |
|                     | Signature ID                          |   |   |   |   |   |   |   |                |   |    |    |    |    |    |    |                  |    |    |    |    |    |    |    |                     |    |    |    |    |    |    |    |
|                     | Signature Generator ID                |   |   |   |   |   |   |   |                |   |    |    |    |    |    |    |                  |    |    |    |    |    |    |    |                     |    |    |    |    |    |    |    |
|                     | (Trigger) Event Second                |   |   |   |   |   |   |   |                |   |    |    |    |    |    |    |                  |    |    |    |    |    |    |    |                     |    |    |    |    |    |    |    |
|                     | (Trigger) Event Microsecond           |   |   |   |   |   |   |   |                |   |    |    |    |    |    |    |                  |    |    |    |    |    |    |    |                     |    |    |    |    |    |    |    |
|                     | Event ID                              |   |   |   |   |   |   |   |                |   |    |    |    |    |    |    |                  |    |    |    |    |    |    |    |                     |    |    |    |    |    |    |    |
|                     | Event Defined Mask                    |   |   |   |   |   |   |   |                |   |    |    |    |    |    |    |                  |    |    |    |    |    |    |    |                     |    |    |    |    |    |    |    |
|                     | Event Impact Flags                    |   |   |   |   |   |   |   | IP Protocol    |   |    |    |    |    |    |    | Network Protocol |    |    |    |    |    |    |    |                     |    |    |    |    |    |    |    |
|                     | Source IP                             |   |   |   |   |   |   |   |                |   |    |    |    |    |    |    |                  |    |    |    |    |    |    |    |                     |    |    |    |    |    |    |    |
| Source OS Fprt UUID | Source Host Type                      |   |   |   |   |   |   |   | Source VLAN ID |   |    |    |    |    |    |    |                  |    |    |    |    |    |    |    | Source OS Fprt UUID |    |    |    |    |    |    |    |
|                     | Source OS Fingerprint UUID, continued |   |   |   |   |   |   |   |                |   |    |    |    |    |    |    |                  |    |    |    |    |    |    |    |                     |    |    |    |    |    |    |    |
|                     | Source OS Fingerprint UUID, continued |   |   |   |   |   |   |   |                |   |    |    |    |    |    |    |                  |    |    |    |    |    |    |    |                     |    |    |    |    |    |    |    |
|                     | Source OS Fingerprint UUID, continued |   |   |   |   |   |   |   |                |   |    |    |    |    |    |    |                  |    |    |    |    |    |    |    |                     |    |    |    |    |    |    |    |
|                     | Source OS Fingerprint UUID, continued |   |   |   |   |   |   |   |                |   |    |    |    |    |    |    |                  |    |    |    |    |    |    |    | Source Criticality  |    |    |    |    |    |    |    |
|                     | Source Criticality, cont              |   |   |   |   |   |   |   | Source User ID |   |    |    |    |    |    |    |                  |    |    |    |    |    |    |    |                     |    |    |    |    |    |    |    |

| Byte                     | 0  |   |   |   |   |   |   |   | 1                               |   |    |    |                        |    |    |    | 2                |    |    |    |    |    |    |    | 3  |    |    |    |    |    |    |    |
|--------------------------|--|---|---|---|---|---|---|---|---------------------------------|---|----|----|------------------------|----|----|----|------------------|----|----|----|----|----|----|----|----|----|----|----|----|----|----|----|
| Bit                      | 0  | 1 | 2 | 3 | 4 | 5 | 6 | 7 | 8                               | 9 | 10 | 11 | 12                     | 13 | 14 | 15 | 16               | 17 | 18 | 19 | 20 | 21 | 22 | 23 | 24 | 25 | 26 | 27 | 28 | 29 | 30 | 31 |
|                          | Source User ID, cont                       |   |   |   |   |   |   |   | Source Port                     |   |    |    |                        |    |    |    | Source Server ID |    |    |    |    |    |    |    |    |    |    |    |    |    |    |    |
|                          | Source Server ID, continued                |   |   |   |   |   |   |   |                                 |   |    |    |                        |    |    |    | Destination IP   |    |    |    |    |    |    |    |    |    |    |    |    |    |    |    |
|                          | Destination IP, continued                  |   |   |   |   |   |   |   |                                 |   |    |    |                        |    |    |    | Dest. Host Type  |    |    |    |    |    |    |    |    |    |    |    |    |    |    |    |
| Dest OS Fingerprint UUID | Dest. VLAN ID                              |   |   |   |   |   |   |   | Destination OS Fingerprint UUID |   |    |    |                        |    |    |    |                  |    |    |    |    |    |    |    |    |    |    |    |    |    |    |    |
|                          | Destination OS Fingerprint UUID, continued |   |   |   |   |   |   |   |                                 |   |    |    |                        |    |    |    |                  |    |    |    |    |    |    |    |    |    |    |    |    |    |    |    |
|                          | Destination OS Fingerprint UUID, continued |   |   |   |   |   |   |   |                                 |   |    |    |                        |    |    |    |                  |    |    |    |    |    |    |    |    |    |    |    |    |    |    |    |
|                          | Destination OS Fingerprint UUID, continued |   |   |   |   |   |   |   |                                 |   |    |    |                        |    |    |    |                  |    |    |    |    |    |    |    |    |    |    |    |    |    |    |    |
|                          | Destination OS Fingerprint UUID, continued |   |   |   |   |   |   |   | Destination Criticality         |   |    |    |                        |    |    |    |                  |    |    |    |    |    |    |    |    |    |    |    |    |    |    |    |
|                          | Dest. User ID                              |   |   |   |   |   |   |   |                                 |   |    |    |                        |    |    |    |                  |    |    |    |    |    |    |    |    |    |    |    |    |    |    |    |
|                          | Destination Port                           |   |   |   |   |   |   |   | Destination Server ID           |   |    |    |                        |    |    |    |                  |    |    |    |    |    |    |    |    |    |    |    |    |    |    |    |
|                          | Destination Server ID, cont.               |   |   |   |   |   |   |   | Blocked                         |   |    |    | Ingress Interface UUID |    |    |    |                  |    |    |    |    |    |    |    |    |    |    |    |    |    |    |    |
|                          | Ingress Interface UUID, continued          |   |   |   |   |   |   |   |                                 |   |    |    |                        |    |    |    |                  |    |    |    |    |    |    |    |    |    |    |    |    |    |    |    |
|                          | Ingress Interface UUID, continued          |   |   |   |   |   |   |   |                                 |   |    |    |                        |    |    |    |                  |    |    |    |    |    |    |    |    |    |    |    |    |    |    |    |
|                          | Ingress Interface UUID, continued          |   |   |   |   |   |   |   |                                 |   |    |    |                        |    |    |    |                  |    |    |    |    |    |    |    |    |    |    |    |    |    |    |    |
|                          | Ingress Interface UUID, continued          |   |   |   |   |   |   |   | Egress Interface UUID           |   |    |    |                        |    |    |    |                  |    |    |    |    |    |    |    |    |    |    |    |    |    |    |    |
|                          | Egress Interface UUID, continued           |   |   |   |   |   |   |   |                                 |   |    |    |                        |    |    |    |                  |    |    |    |    |    |    |    |    |    |    |    |    |    |    |    |
|                          | Egress Interface UUID, continued           |   |   |   |   |   |   |   |                                 |   |    |    |                        |    |    |    |                  |    |    |    |    |    |    |    |    |    |    |    |    |    |    |    |
|                          | Egress Interface UUID, continued           |   |   |   |   |   |   |   |                                 |   |    |    |                        |    |    |    |                  |    |    |    |    |    |    |    |    |    |    |    |    |    |    |    |
|                          | Egress Interface UUID, continued           |   |   |   |   |   |   |   | Ingress Zone UUID               |   |    |    |                        |    |    |    |                  |    |    |    |    |    |    |    |    |    |    |    |    |    |    |    |
|                          | Ingress Zone UUID                          |   |   |   |   |   |   |   |                                 |   |    |    |                        |    |    |    |                  |    |    |    |    |    |    |    |    |    |    |    |    |    |    |    |
|                          | Ingress Zone UUID, continued               |   |   |   |   |   |   |   |                                 |   |    |    |                        |    |    |    |                  |    |    |    |    |    |    |    |    |    |    |    |    |    |    |    |
|                          | Ingress Zone UUID, continued               |   |   |   |   |   |   |   |                                 |   |    |    |                        |    |    |    |                  |    |    |    |    |    |    |    |    |    |    |    |    |    |    |    |
|                          | Ingress Zone UUID, continued               |   |   |   |   |   |   |   | Egress Zone UUID                |   |    |    |                        |    |    |    |                  |    |    |    |    |    |    |    |    |    |    |    |    |    |    |    |
|                          | Egress Zone UUID                           |   |   |   |   |   |   |   |                                 |   |    |    |                        |    |    |    |                  |    |    |    |    |    |    |    |    |    |    |    |    |    |    |    |

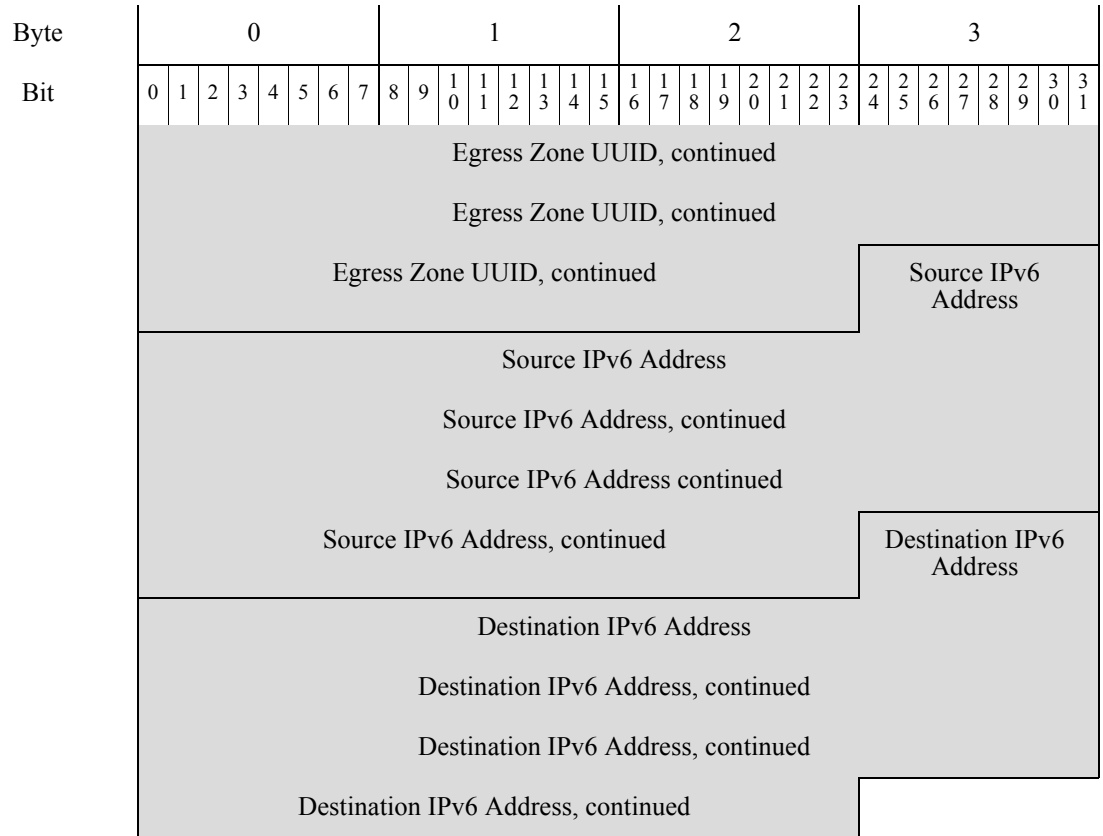

Note that the record structure includes a String block type, which is a block in series 1. For information about series 1 blocks, see [Understanding Discovery \(Series 1\) Blocks, page 4-55](#).

**Table 3-24** Correlation Event 5.1+ Data Fields

| Field                      | Data Type | Description   |
|----------------------------|-----------|---|
| Correlation Block Type     | uint32    | Indicates a correlation event data block follows. This field always has a value of 128. See <a href="#">Understanding Discovery (Series 1) Blocks, page 4-55</a> .  |
| Correlation Block Length   | uint32    | Length of the correlation data block, which includes 8 bytes for the correlation block type and length plus the correlation data that follows.  |
| Device ID                  | uint32    | Internal identification number of the managed device or Defense Center that generated the correlation event. A value of 0 indicates the Defense Center. You can obtain managed device names by requesting Version 3 metadata. See <a href="#">Managed Device Record Metadata, page 3-30</a> for more information. |
| (Correlation) Event Second | uint32    | UNIX timestamp indicating the time that the correlation event was generated (in seconds from 01/01/1970).   |
| Event ID                   | uint32    | Correlation event identification number.  |
| Policy ID                  | uint32    | Identification number of the correlation policy that was violated. See <a href="#">Server Record, page 4-14</a> for information about how to obtain policy identification numbers from the database.  |

Table 3-24 Correlation Event 5.1+ Data Fields (continued)

| Field                       | Data Type | Description   |
|-----------------------------|-----------|---|
| Rule ID                     | uint32    | Identification number of the correlation rule that triggered to violate the policy. See <a href="#">Server Record, page 4-14</a> for information about how to obtain policy identification numbers from the database.                               |
| Priority                    | uint32    | Priority assigned to the event. This is an integer value from 0 to 5.   |
| String Block Type           | uint32    | Initiates a string data block that contains the correlation violation event description. This value is always set to 0. For more information about string blocks, see <a href="#">String Data Block, page 4-63</a> .                                |
| String Block Length         | uint32    | Number of bytes in the event description string block, which includes four bytes for the string block type and four bytes for the string block length, plus the number of bytes in the description.   |
| Description                 | string    | Description of the correlation event.   |
| Event Type                  | uint8     | Indicates whether the correlation event was triggered by an intrusion, host discovery, or user event: <ul style="list-style-type: none"> <li>• 1 - intrusion</li> <li>• 2 - host discovery</li> <li>• 3 - user</li> </ul>                           |
| Event Device ID             | uint32    | Identification number of the device that generated the event that triggered the correlation event. You can obtain device name by requesting Version 3 metadata. See <a href="#">Managed Device Record Metadata, page 3-30</a> for more information. |
| Signature ID                | uint32    | If the event was an intrusion event, indicates the rule identification number that corresponds with the event. Otherwise, the value is 0.   |
| Signature Generator ID      | uint32    | If the event was an intrusion event, indicates the ID number of the FireSIGHT System preprocessor or rules engine that generated the event.   |
| (Trigger) Event Second      | uint32    | UNIX timestamp indicating the time of the event that triggered the correlation policy rule (in seconds from 01/01/1970).  |
| (Trigger) Event Microsecond | uint32    | Microsecond (one millionth of a second) increment that the event was detected.  |
| Event ID                    | uint32    | Identification number of the event generated by the Cisco device.   |
| Event Defined Mask          | bits[32]  | Set bits in this field indicate which of the fields that follow in the message are valid. See <a href="#">Table 3-25 on page 3-43</a> for a list of each bit value.   |

Table 3-24 Correlation Event 5.1+ Data Fields (continued)

| Field              | Data Type | Description   |
|--------------------|-----------|---|
| Event Impact Flags | bits[8]   | <p>Impact flag value of the event. The low-order eight bits indicate the impact level. Values are:</p> <ul style="list-style-type: none"> <li>0x01 (bit 0) - Source or destination host is in a network monitored by the system.</li> <li>0x02 (bit 1) - Source or destination host exists in the network map.</li> <li>0x04 (bit 2) - Source or destination host is running a server on the port in the event (if TCP or UDP) or uses the IP protocol.</li> <li>0x08 (bit 3) - There is a vulnerability mapped to the operating system of the source or destination host in the event.</li> <li>0x10 (bit 4) - There is a vulnerability mapped to the server detected in the event.</li> <li>0x20 (bit 5) - The event caused the managed device to drop the session (used only when the device is running in inline, switched, or routed deployment). Corresponds to blocked status in the FireSIGHT System web interface.</li> <li>0x40 (bit 6) - The rule that generated this event contains rule metadata setting the impact flag to red. The source or destination host is potentially compromised by a virus, trojan, or other piece of malicious software.</li> <li>0x80 (bit 7) - There is a vulnerability mapped to the client detected in the event. (version 5.0+ only)</li> </ul> <p>The following impact level values map to specific priorities on the Defense Center. An x indicates the value can be 0 or 1:</p> <ul style="list-style-type: none"> <li>gray (0, unknown): 00X00000</li> <li>red (1, vulnerable): XXXX1XXX, XXX1XXXX, X1XXXXXX, 1XXXXXXX (Version 5.0+ only)</li> <li>orange (2, potentially vulnerable): 00X0011X</li> <li>yellow (3, currently not vulnerable): 00X0001X</li> <li>blue (4, unknown target): 00X00001</li> </ul> |
| IP Protocol        | uint8     | Identifier of the IP protocol associated with the event, if applicable.   |
| Network Protocol   | uint16    | Network protocol associated with the event, if applicable.  |
| Source IP Address  | uint8[4]  | This field is reserved but no longer populated. The Source IPv4 address is stored in the Source IPv6 Address field. See <a href="#">IP Addresses, page 1-5</a> for more information.  |
| Source Host Type   | uint8     | <p>Source host's type:</p> <ul style="list-style-type: none"> <li>0 - Host</li> <li>1 - Router</li> <li>2 - Bridge</li> </ul>   |

Table 3-24 Correlation Event 5.1+ Data Fields (continued)

| Field                           | Data Type | Description   |
|---------------------------------|-----------|---|
| Source VLAN ID                  | uint16    | Source host's VLAN identification number, if applicable.  |
| Source OS Fingerprint UUID      | uint8[16] | A fingerprint ID number that acts a unique identifier for the source host's operating system.<br>See <a href="#">Server Record, page 4-14</a> for information about obtaining the values that map to the fingerprint IDs.         |
| Source Criticality              | uint16    | User-defined criticality value for the source host: <ul style="list-style-type: none"> <li>0 - None</li> <li>1 - Low</li> <li>2 - Medium</li> <li>3 - High</li> </ul>   |
| Source User ID                  | uint32    | Identification number for the user logged into the source host, as identified by the system.  |
| Source Port                     | uint16    | Source port in the event.   |
| Source Server ID                | uint32    | Identification number for the server running on the source host.  |
| Destination IP Address          | uint8[4]  | This field is reserved but no longer populated. The Destination IPv4 address is stored in the Destination IPv6 Address field. See <a href="#">IP Addresses, page 1-5</a> for more information.                                    |
| Destination Host Type           | uint8     | Destination host's type: <ul style="list-style-type: none"> <li>0 - Host</li> <li>1 - Router</li> <li>2 - Bridge</li> </ul>   |
| Destination VLAN ID             | uint16    | Destination host's VLAN identification number, if applicable.   |
| Destination OS Fingerprint UUID | uint8[16] | A fingerprint ID number that acts as a unique identifier for the destination host's operating system.<br>See <a href="#">Server Record, page 4-14</a> for information about obtaining the values that map to the fingerprint IDs. |
| Destination Criticality         | uint16    | User-defined criticality value for the destination host: <ul style="list-style-type: none"> <li>0 - None</li> <li>1 - Low</li> <li>2 - Medium</li> <li>3 - High</li> </ul>  |
| Destination User ID             | uint32    | Identification number for the user logged into the destination host, as identified by the system.   |
| Destination Port                | uint16    | Destination port in the event.  |
| Destination Service ID          | uint32    | Identification number for the server running on the source host.  |



Table 3-24 Correlation Event 5.1+ Data Fields (continued)

| Field                    | Data Type | Description   |
|--------------------------|-----------|---|
| Blocked                  | uint8     | Value indicating what happened to the packet that triggered the intrusion event. <ul style="list-style-type: none"> <li>0 - Intrusion event not dropped</li> <li>1 - Intrusion event was dropped (drop when deployment is inline, switched, or routed)</li> <li>2 - The packet that triggered the event would have been dropped, if the intrusion policy had been applied to a device in inline, switched, or routed deployment.</li> </ul> |
| Ingress Interface UUID   | uint8[16] | An interface ID that acts as the unique identifier for the ingress interface associated with correlation event.   |
| Egress Interface UUID    | uint8[16] | An interface ID that acts as the unique identifier for the egress interface associated with correlation event.  |
| Ingress Zone UUID        | uint8[16] | A zone ID that acts as the unique identifier for the ingress security zone associated with correlation event.   |
| Egress Zone UUID         | uint8[16] | A zone ID that acts as the unique identifier for the egress security zone associated with correlation event.  |
| Source IPv6 Address      | uint8[16] | IP address of the source host in the event, in IPv6 address octets.   |
| Destination IPv6 Address | uint8[16] | IP address of the destination host in the event, in IPv6 address octets.  |

The following table describes each Event Defined Mask value.

Table 3-25 Event Defined Values

| Description                | Mask Value |
|----------------------------|------------|
| Event Impact Flags         | 0x00000001 |
| IP Protocol                | 0x00000002 |
| Network Protocol           | 0x00000004 |
| Source IP                  | 0x00000008 |
| Source Host Type           | 0x00000010 |
| Source VLAN ID             | 0x00000020 |
| Source Fingerprint ID      | 0x00000040 |
| Source Criticality         | 0x00000080 |
| Source Port                | 0x00000100 |
| Source Server              | 0x00000200 |
| Destination IP             | 0x00000400 |
| Destination Host Type      | 0x00000800 |
| Destination VLAN ID        | 0x00001000 |
| Destination Fingerprint ID | 0x00002000 |

Table 3-25 Event Defined Values (continued)

| Description             | Mask Value |
|-------------------------|------------|
| Destination Criticality | 0x00004000 |
| Destination Port        | 0x00008000 |
| Destination Server      | 0x00010000 |
| Source User             | 0x00020000 |
| Destination User        | 0x00040000 |

## Understanding Series 2 Data Blocks

Beginning in version 4.10.0, the eStreamer service uses a second series of data blocks to package certain records such as intrusion event extra data. See [Table 3-26 on page 3-45](#) for a list of all block types in the series. Series 2 blocks, like series 1 blocks, support variable-length fields and hierarchies of nested blocks. The series 2 block types include primitive blocks that provide the same mechanism for encapsulating nested inner blocks as the series 1 primitive block types. However, series 2 blocks and series 1 blocks have separate numbering systems.

The following example shows the how primitive blocks are used. The list data block (series 2 block type 31) defines an array of operating system fingerprints (each of which is a type 87 block itself with variable length). The overall type 31 data block length is self-describing via the Data Block Length field, which contains the length of the data portion of the message, excluding the 8 bytes in the block type and block length fields.

| Byte                | 0   |   |   |   |   |   |   |   | 1 |   |    |    |    |    |    |    | 2  |    |    |    |    |    |    |    | 3  |    |    |    |    |    |    |    |
|---------------------|---|---|---|---|---|---|---|---|---|---|----|----|----|----|----|----|----|----|----|----|----|----|----|----|----|----|----|----|----|----|----|----|
| Bit                 | 0   | 1 | 2 | 3 | 4 | 5 | 6 | 7 | 8 | 9 | 10 | 11 | 12 | 13 | 14 | 15 | 16 | 17 | 18 | 19 | 20 | 21 | 22 | 23 | 24 | 25 | 26 | 27 | 28 | 29 | 30 | 31 |
|                     | List Data Block Type (2)                      |   |   |   |   |   |   |   |   |   |    |    |    |    |    |    |    |    |    |    |    |    |    |    |    |    |    |    |    |    |    |    |
|                     | Data Block Length                             |   |   |   |   |   |   |   |   |   |    |    |    |    |    |    |    |    |    |    |    |    |    |    |    |    |    |    |    |    |    |    |
| Server Fingerprints | Operating System Fingerprint Block Type (87)* |   |   |   |   |   |   |   |   |   |    |    |    |    |    |    |    |    |    |    |    |    |    |    |    |    |    |    |    |    |    |    |
|                     | Operating System Fingerprint Block Length     |   |   |   |   |   |   |   |   |   |    |    |    |    |    |    |    |    |    |    |    |    |    |    |    |    |    |    |    |    |    |    |
|                     | Operating System Server Fingerprint Data...   |   |   |   |   |   |   |   |   |   |    |    |    |    |    |    |    |    |    |    |    |    |    |    |    |    |    |    |    |    |    |    |

In the following table, the Data Block Status field indicates whether the block is current (the latest version) or legacy (used in an older version and can still be requested through eStreamer).

**Table 3-26**      *Series 2 Block Types*

| Type | Content                                      | Data Block Status | Description  |
|------|--|-------------------|--|
| 0    | String                                       | Current           | Encapsulates variable string data. See <a href="#">String Data Block, page 3-48</a> for more information.  |
| 1    | BLOB   | Current           | Encapsulates binary data and is used specifically for banners. See <a href="#">BLOB Data Block, page 3-48</a> for more information.  |
| 2    | List   | Current           | Encapsulates a list of other data blocks. See <a href="#">List Data Block, page 3-49</a> for more information.   |
| 3    | Generic List                                 | Current           | Encapsulates a list of other data blocks. For deserialization, it is the equivalent of the List data block. See <a href="#">Generic List Data Block, page 3-50</a> for more information.   |
| 4    | Event Extra Data                             | Current           | Contains intrusion event extra data. See <a href="#">Intrusion Event Extra Data Record, page 3-21</a> for more information.  |
| 5    | Extra Data Type                              | Current           | Contains extra data metadata. See <a href="#">Intrusion Event Extra Data Metadata, page 3-23</a> for more information.   |
| 14   | UUID String Mapping                          | Current           | Block used by various metadata messages to map UUID values to descriptive strings. See <a href="#">UUID String Mapping Data Block, page 3-51</a> .   |
| 15   | Access Control Policy Rule ID Metadata       | Current           | Contains metadata for access control rules. See <a href="#">Access Control Policy Rule ID Metadata Block, page 3-52</a> .  |
| 16   | Malware Event                                | Legacy            | Contains information on malware events, such as the malware detected or quarantined within a Collective Security Intelligence Cloud, the detection method, and hosts and users affected by the malware. See <a href="#">Malware Event Data Block 5.1, page B-32</a> . Deprecated by block 24, <a href="#">Malware Event Data Block 5.3.1+, page 3-64</a> . |
| 19   | ICMP Type Data Block                         | Current           | Contains metadata describing ICMP types. See <a href="#">ICMP Type Data Block, page 3-53</a> .   |
| 20   | ICMP Code Data Block                         | Current           | Contains metadata describing ICMP codes. See <a href="#">ICMP Code Data Block, page 3-54</a> .   |
| 21   | Access Control Policy Rule Reason Data Block | Current           | Contains information explaining access control policy rule reasons. See <a href="#">Access Control Policy Rule Reason Data Block, page 3-55</a> .  |
| 22   | IP Reputation Category Data Block            | Current           | Contains information on IP reputation categories explaining why an IP address was blocked. See <a href="#">IP Reputation Category Data Block, page 3-56</a> .  |
| 23   | File Event                                   | Legacy            | Contains information on file events, such as the source, SHA hash, and the disposition of the file. See <a href="#">File Event for 5.1.1.x, page B-109</a> . It is superseded by block 32, <a href="#">Access Control Policy Rule ID Metadata Block, page 3-52</a> .   |

Table 3-26 Series 2 Block Types (continued)

| Type | Content                       | Data Block Status | Description   |
|------|-------------------------------|-------------------|---|
| 24   | Malware Event                 | Legacy            | Contains information on malware events, such as the malware detected or quarantined within a Collective Security Intelligence Cloud, the detection method, and hosts and users affected by the malware. See <a href="#">Malware Event Data Block 5.1.1.x, page B-36</a> . Deprecates block 16, <a href="#">Malware Event Data Block 5.1, page B-32</a> . Deprecated by block 33, <a href="#">Malware Event Data Block 5.3.1+, page 3-64</a> . |
| 25   | Intrusion Event               | Legacy            | Contains information on intrusion events, including information to match intrusion events with connection and malware events. See <a href="#">Intrusion Event Record 5.1.1.x, page B-24</a> . Deprecated by block 34, <a href="#">Intrusion Event Record 5.2.x, page B-11</a> .   |
| 26   | File Event SHA Hash           | Legacy            | Contains the SHA hash and name of files that have been identified as containing malware. See <a href="#">File Event SHA Hash for 5.1.1-5.2.x, page B-122</a> . Deprecated by block 40, <a href="#">File Event SHA Hash for 5.3+, page 3-71</a> .  |
| 27   | Rule Documentation Data Block | Current           | Contains information about rules used to generate events. See <a href="#">Rule Documentation Data Block for 5.2+, page 3-73</a> for more information.   |
| 28   | Geolocation Data Block        | Current           | Contains country codes and associated country name. See <a href="#">Geolocation Data Block for 5.2+, page 3-76</a> .  |
| 32   | File Event                    | Legacy            | Contains information on file events, such as the source, SHA hash, and the disposition of the file. See <a href="#">File Event for 5.2.x, page B-112</a> . It deprecates <a href="#">File Event for 5.1.1.x, page B-109</a> . Deprecated by block 38, <a href="#">File Event for 5.3, page B-116</a> .  |
| 33   | Malware Event                 | Current           | Contains information on malware events, such as the malware detected or quarantined within a Collective Security Intelligence Cloud, the detection method, and hosts and users affected by the malware. See <a href="#">Malware Event Data Block 5.2.x, page B-42</a> . Deprecates block 24, <a href="#">Malware Event Data Block 5.1.1.x, page B-36</a> . Deprecated by block 35, <a href="#">Malware Event Data Block 5.3, page B-48</a> .  |
| 34   | Intrusion Event               | Legacy            | Contains information on intrusion events, including information to match intrusion events with connection and malware events. See <a href="#">Intrusion Event Record 5.2.x, page B-11</a> . Deprecates block 25. Deprecated by block 41, <a href="#">Intrusion Event Record 5.3, page B-17</a> .  |
| 35   | Malware Event                 | Legacy            | Contains information on malware events, including IOC information. See <a href="#">Malware Event Data Block 5.3, page B-48</a> . Deprecates block 33, <a href="#">Malware Event Data Block 5.2.x, page B-42</a> . Deprecated by block 44, <a href="#">Malware Event Data Block 5.3, page B-48</a> .   |

Table 3-26 Series 2 Block Types (continued)

| Type | Content             | Data Block Status | Description   |
|------|---------------------|-------------------|---|
| 38   | File Event          | Legacy            | Contains information on file events, such as the source, SHA hash, and the disposition of the file. See <a href="#">File Event for 5.3, page B-116</a> . It deprecates block 32. Deprecates by block 43, <a href="#">File Event for 5.3.1+, page 3-57</a> .             |
| 39   | IOC Name Data Block | Current           | Contains information about IOCs. See <a href="#">IOC Name Data Block for 5.3+, page 4-27</a>  |
| 40   | File Event SHA Hash | Current           | Contains the SHA hash and name of files that have been identified as containing malware. See <a href="#">File Event SHA Hash for 5.3+, page 3-71</a> . Deprecates block 26, <a href="#">File Event SHA Hash for 5.1.1-5.2.x, page B-122</a> .                           |
| 41   | Intrusion Event     | Legacy            | Contains information on intrusion events, including information to match intrusion events with IOCs. See <a href="#">Intrusion Event Record 5.3, page B-17</a> . Deprecates block 34. Deprecates by block 42, <a href="#">Intrusion Event Record 5.3.1+, page 3-6</a> . |
| 42   | Intrusion Event     | Current           | Contains information on intrusion events, including information to match intrusion events with IOCs. See <a href="#">Intrusion Event Record 5.3.1+, page 3-6</a> . Deprecates block 41, <a href="#">Intrusion Event Record 5.3, page B-17</a> .                         |
| 43   | File Event          | Current           | Contains information on file events, such as the source, SHA hash, and the disposition of the file. See <a href="#">File Event for 5.3.1+, page 3-57</a> . Deprecates block 38, <a href="#">File Event for 5.3, page B-116</a> .  |
| 44   | Malware Event       | Current           | Contains information on malware events, including IOC information. See <a href="#">Malware Event Data Block 5.3.1+, page 3-64</a> . Deprecates block 35, <a href="#">Malware Event Data Block 5.3, page B-48</a> .  |

## Series 2 Primitive Data Blocks

Both series 2 and series 1 blocks include a set of primitives that are used to encapsulate lists of variable-length blocks as well as variable-length strings and BLOBs within messages. These primitive blocks have the standard eStreamer block header discussed above in [Data Block Header, page 2-24](#), but they appear only within other data blocks. Any number can be included in a given block type. For details on the structure of these blocks, see the following:

- [String Data Block, page 3-48](#)
- [BLOB Data Block, page 3-48](#)
- [List Data Block, page 3-49](#)
- [Generic List Data Block, page 3-50](#)

## String Data Block

The eStreamer service uses the String data block to send string data in messages. These blocks commonly appear within other data blocks to identify, for example, operating system or server names.

Empty String data blocks (containing no data, only the header fields) have a block length of 8. eStreamer uses an empty String data block when it has no content for a string value, as might happen, for example, in the OS vendor string field in an Operating System data block when the vendor of the operating system is unknown.

The String data block has a block type of 0 in the series 2 group of blocks.



### Note

Strings returned in this data block are not always null-terminated (that is, the string characters are not always followed by a 0).

The following diagram shows the format of the String data block:

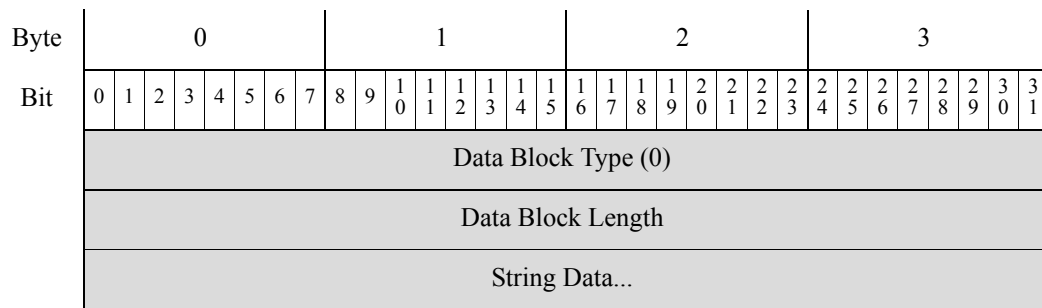

The following table describes the fields of the String data block.

**Table 3-27** String Block Fields

| Field             | Data Type | Description  |
|-------------------|-----------|--|
| Data Block Type   | uint32    | Initiates a String data block. This value is always 0.   |
| Data Block Length | uint32    | Combined length in bytes of the string data block header and string data.                              |
| String Data       | string    | Contains the string data and may contain a terminating character (null byte) at the end of the string. |

## BLOB Data Block

The eStreamer service uses the BLOB data block to convey binary data. For example, host discovery records use the BLOB block to hold captured server banners. The BLOB data block has a block type of 1 in the series 2 group of blocks.

The following diagram shows the format of the BLOB data block:

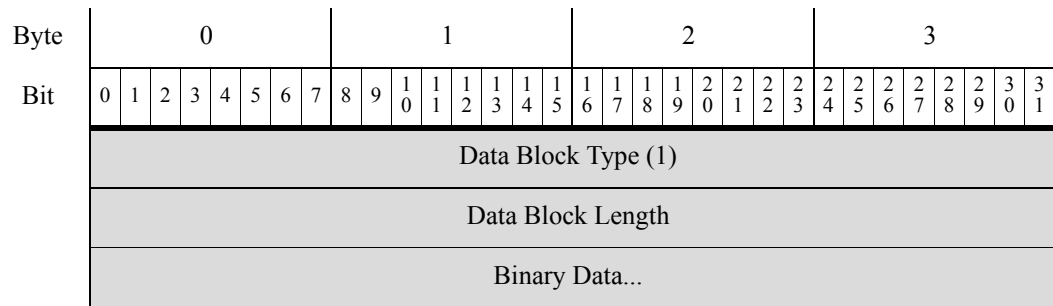

The following table describes the fields of the BLOB data block.

**Table 3-28** BLOB Data Block Fields

| Field             | Data Type | Description   |
|-------------------|-----------|---|
| Data Block Type   | uint32    | Initiates a BLOB data block. This value is always 1.  |
| Data Block Length | uint32    | Number of bytes in the BLOB data block, including eight bytes for the BLOB block type and length fields, plus the length of the binary data that follows. |
| Binary Data       | variable  | Contains binary data such as a server banner.   |

## List Data Block

The eStreamer service uses the List data block to encapsulate a list of data blocks. For example, eStreamer can use the List data block to send a list of TCP servers, each of which is itself a data block. The List data block has a block type of 2 in the series 2 group of blocks.

The following diagram shows the basic format of a List data block:

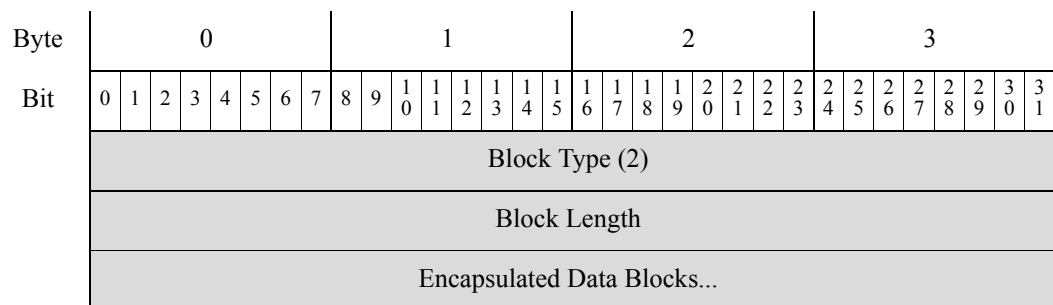

The following table describes the fields of the List data block.

**Table 3-29** List Data Fields

| Field                    | Data Type | Description   |
|--------------------------|-----------|---|
| Block Type               | uint32    | Initiates a List data block. This value is always 2.  |
| Block Length             | uint32    | Number of bytes in the List block and encapsulated data. For example, if there were three Sub-Server data blocks included in the list, the value here would include the total number of bytes in the Sub-Server blocks, plus eight bytes for the List block header. |
| Encapsulated Data Blocks | variable  | Encapsulated data blocks up to the maximum number of bytes in the list block length.  |

## Generic List Data Block

The eStreamer service uses the Generic List data block to encapsulate a list of data blocks. For example, the Host Profile data block contains information about multiple client applications and uses the Generic List block to embed a list of Client Application data blocks in the message. The Generic List data block has a block type of 3 in the series 2 group of blocks.

The following diagram shows the basic structure of a Generic List data block:

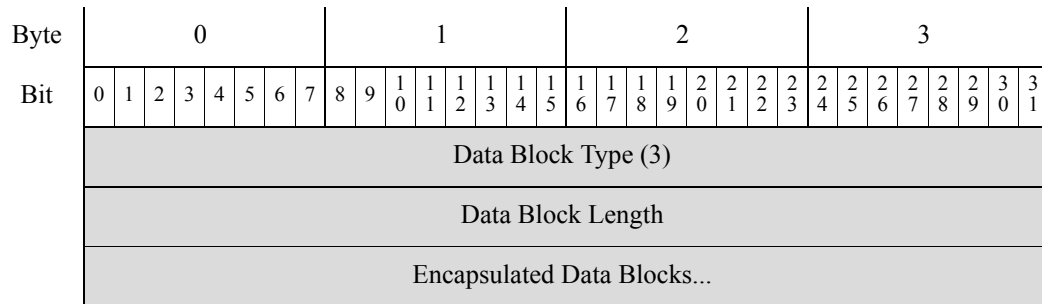

The following table describes the fields of the Generic List data block.

**Table 3-30** Generic List Data Block Fields

| Field                    | Number of Bytes | Description  |
|--------------------------|-----------------|--|
| Data Block Type          | uint32          | Initiates a Generic List data block. This value is always 3.   |
| Data Block Length        | uint32          | Number of bytes in the Generic List block and encapsulated data blocks. This number includes the eight bytes of the generic list block header fields, plus the total number of bytes in all of the encapsulated data blocks. |
| Encapsulated Data Blocks | variable        | Encapsulated data blocks up to the maximum number of bytes in the Generic List block length.   |



## UUID String Mapping Data Block

The eStreamer service uses the UUID String Mapping data block in various metadata messages to map UUID values to descriptive strings. The UUID String Mapping data block has a block type of 14 in series 2.

The following diagram shows the structure of the UUID String Mapping data block.

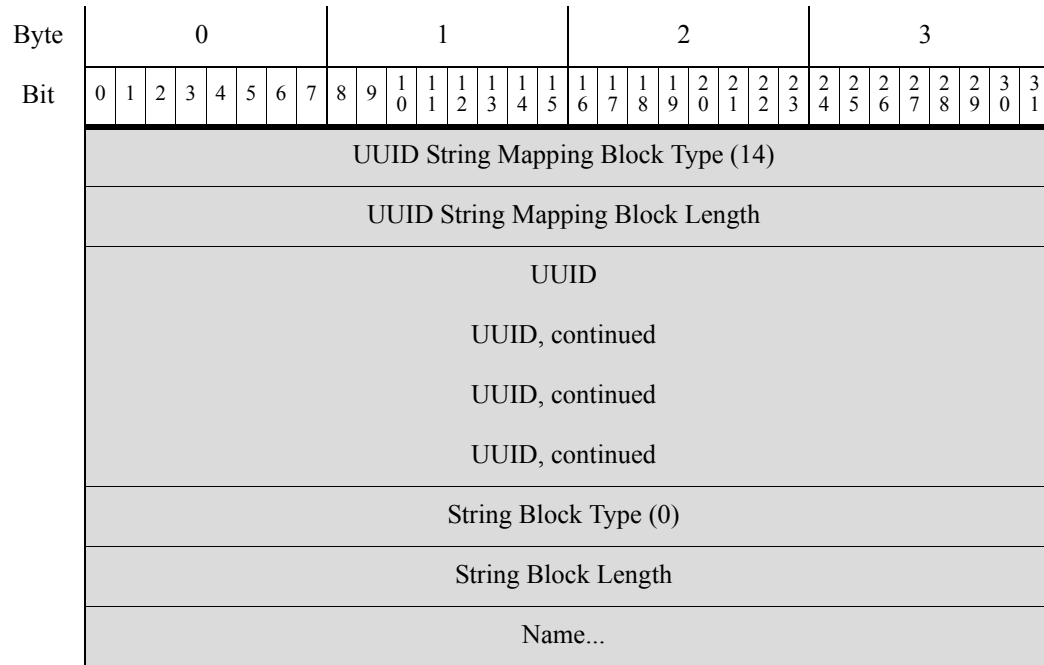

The following table describes the fields in the UUID String Mapping data block.

**Table 3-31** *UUID String Mapping Data Block Fields*

| Field                            | Data Type | Description  |
|----------------------------------|-----------|--|
| UUID String Mapping Block Type   | uint32    | Initiates a UUID String Mapping block. This value is always 14.  |
| UUID String Mapping Block Length | uint32    | Total number of bytes in the UUID String Mapping block, including eight bytes for the UUID String Mapping block type and length fields, plus the number of bytes of data that follows. |
| UUID                             | uint8[16] | The unique identifier for the event or other object the UUID identifies.   |
| String Block Type                | uint32    | Initiates a String data block containing the descriptive name associated with the UUID. This value is always 0.  |
| String Block Length              | uint32    | The number of bytes included in the name String data block, including eight bytes for the block type and header fields plus the number of bytes in the Name field.                     |
| Name                             | string    | The descriptive name.  |

## Access Control Policy Rule ID Metadata Block

The eStreamer service uses the Access Control Policy Rule ID metadata block to contain information about access control policy rule IDs. This data block has a block type of 15 in series 2.

The following diagram shows the structure of the Access Control Policy Rule ID metadata block.

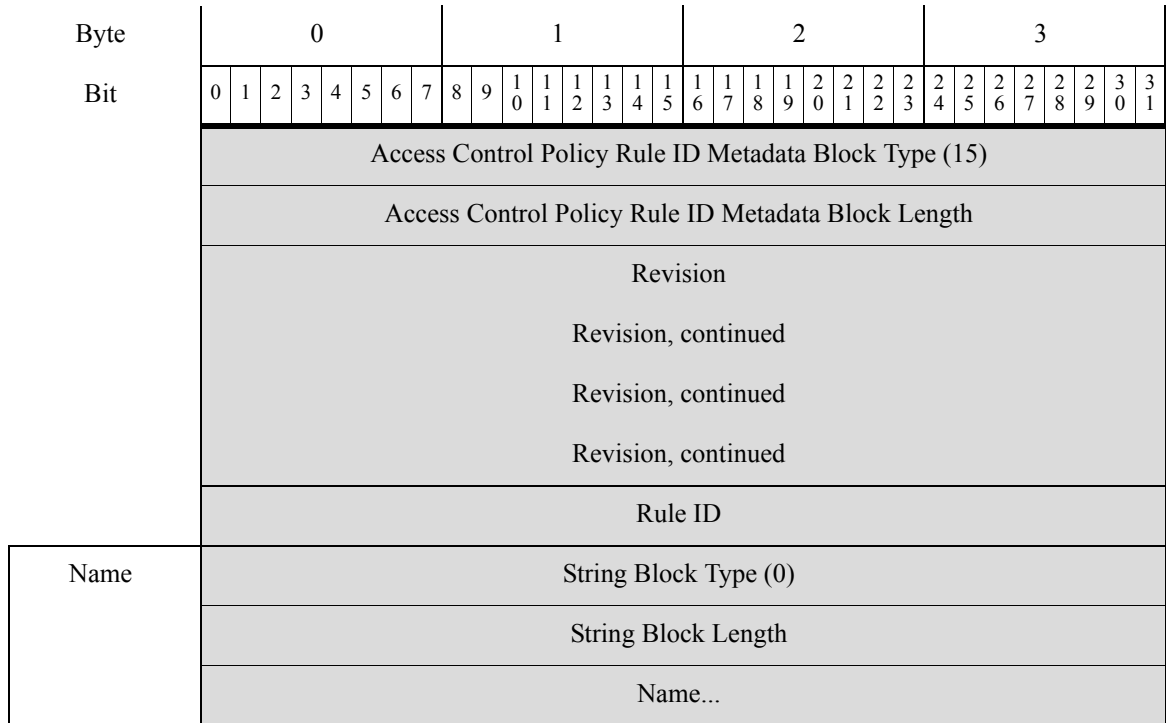

The following table describes the fields in the Access Control Policy Rule ID Metadata block.

**Table 3-32** Access Control Policy Rule ID Metadata Block Fields

| Field   | Data Type | Description   |
|---|-----------|---|
| Access Control Policy Rule ID Metadata Block Type   | uint32    | Initiates a Access Control Policy Rule ID Metadata block. This value is always 15.  |
| Access Control Policy Rule ID Metadata Block Length | uint32    | Total number of bytes in the Access Control Policy Rule ID block, including eight bytes for the Access Control Policy Rule ID metadata block type and length fields, plus the number of bytes of data that follows. |
| Revision  | uint8[16] | Revision number of the rule associated with the triggered correlation event.  |
| Rule ID   | uint32    | Internal identifier for the rule that triggered the event.  |
| String Block Type                                   | uint32    | Initiates a String data block containing the descriptive name associated with the access control policy rule. This value is always 0.   |

**Table 3-32** Access Control Policy Rule ID Metadata Block Fields (continued)

| Field               | Data Type | Description  |
|---------------------|-----------|--|
| String Block Length | uint32    | The number of bytes included in the name String data block, including eight bytes for the block type and header fields plus the number of bytes in the Name field. |
| Name                | string    | The descriptive name of the access control policy rule.  |

## ICMP Type Data Block

The eStreamer service uses the ICMP Type data block to contain information about ICMP Types. This data block has a record type of 260, and a block type of 19 in series 2.

The following diagram shows the structure of the ICMP Type data block.

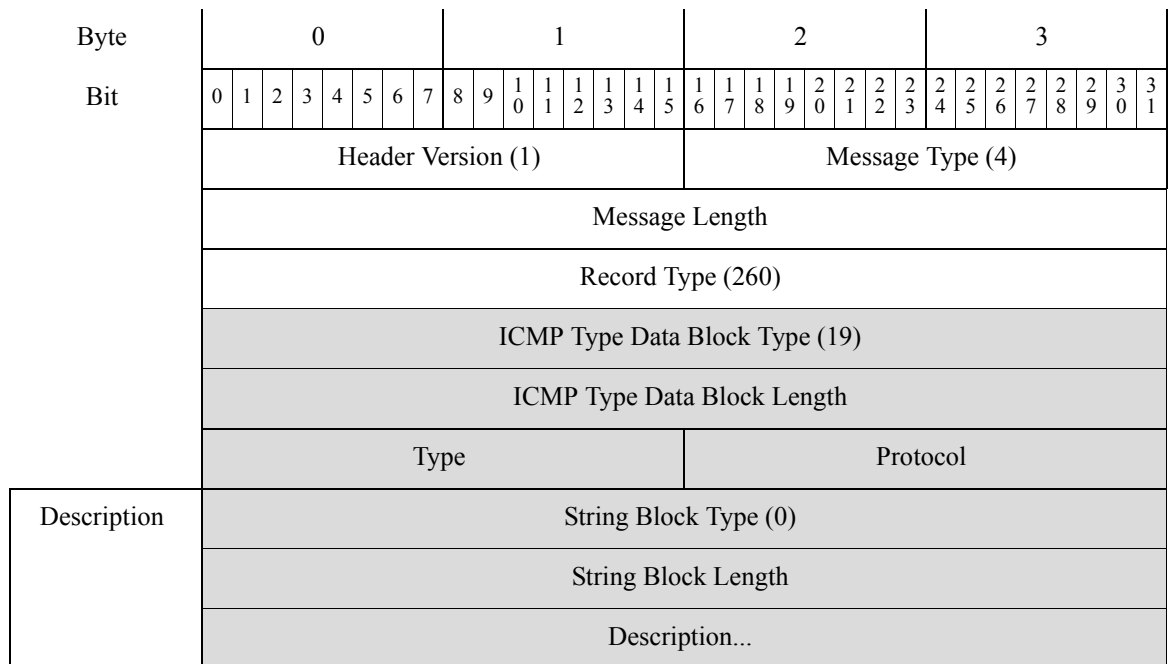

The following table describes the fields in the ICMP Type data block.

**Table 3-33** ICMP Type Data Block Fields

| Field                       | Data Type | Description  |
|-----------------------------|-----------|--|
| ICMP Type Data Block Type   | uint32    | Initiates an ICMP Type data block. This value is always 19.  |
| ICMP Type Data Block Length | uint32    | Total number of bytes in the ICMP Type data block, including eight bytes for the ICMP Type data block type and length fields, plus the number of bytes of data that follows. |
| Type                        | uint16    | The ICMP type of the event.  |

Table 3-33 ICMP Type Data Block Fields (continued)

| Field               | Data Type | Description   |
|---------------------|-----------|---|
| Protocol            | uint16    | IANA-specified protocol number. For example: <ul style="list-style-type: none"> <li>0 - IP</li> <li>1 - ICMP</li> <li>6 - TCP</li> <li>17 - UDP</li> </ul>                |
| String Block Type   | uint32    | Initiates a String data block containing the description of the ICMP type. This value is always 0.  |
| String Block Length | uint32    | The number of bytes included in the name String data block, including eight bytes for the block type and header fields plus the number of bytes in the Description field. |
| Description         | string    | Description of the ICMP type for the event.   |

## ICMP Code Data Block

The eStreamer service uses the ICMP Code data block to contain information about access control policy rule IDs. This data block has a record type of 270, and block type of 20 in series 2.

The following diagram shows the structure of the Access Control Policy Rule ID metadata block.

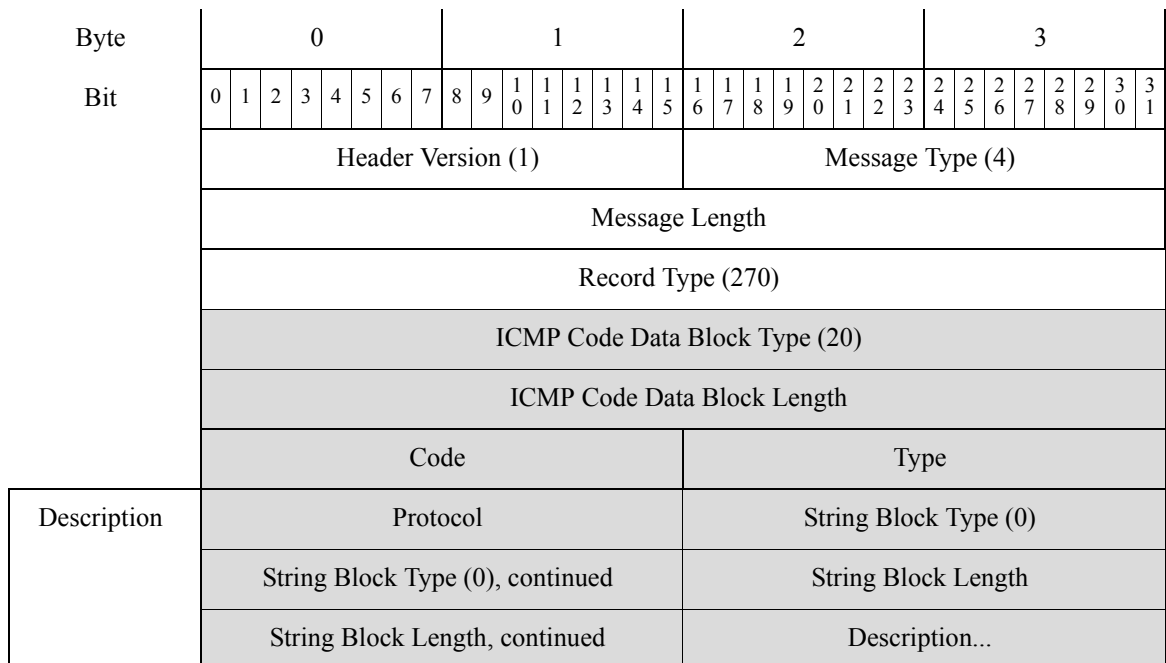

The following table describes the fields in the ICMP Code data block.

**Table 3-34** ICMP Code Data Block Fields

| Field                       | Data Type | Description  |
|-----------------------------|-----------|--|
| ICMP Code Data Block Type   | uint32    | Initiates a ICMP Code data block. This value is always 20.   |
| ICMP Code Data Block Length | uint32    | Total number of bytes in the ICMP Code data block, including eight bytes for the ICMP Code data block type and length fields, plus the number of bytes of data that follows. |
| Code                        | uint16    | The ICMP code of the event.  |
| Type                        | uint16    | The ICMP type of the event.  |
| Protocol                    | uint16    | IANA-specified protocol number. For example: <ul style="list-style-type: none"> <li>• 0 - IP</li> <li>• 1 - ICMP</li> <li>• 6 - TCP</li> <li>• 17 - UDP</li> </ul>           |
| String Block Type           | uint32    | Initiates a String data block containing the description of the ICMP code. This value is always 0.   |
| String Block Length         | uint32    | The number of bytes included in the name String data block, including eight bytes for the block type and header fields plus the number of bytes in the Description field.    |
| Description                 | string    | Description of the ICMP code for the event.  |

## Access Control Policy Rule Reason Data Block

The eStreamer service uses the Access Control Rule Policy Rule Reason Data block to contain information about access control policy rule IDs. This data block has a block type of 21 in series 2.

The following diagram shows the structure of the Access Control Policy Rule ID metadata block.

| Byte        | 0  |   |   |   |   |   |   |   | 1 |   |   |   |   |   |   |   | 2                     |   |   |   |   |   |   |   | 3 |   |   |   |   |   |   |   |   |
|-------------|--|---|---|---|---|---|---|---|---|---|---|---|---|---|---|---|-----------------------|---|---|---|---|---|---|---|---|---|---|---|---|---|---|---|---|
| Bit         | 0  | 1 | 2 | 3 | 4 | 5 | 6 | 7 | 8 | 9 | 0 | 1 | 2 | 3 | 4 | 5 | 6                     | 7 | 8 | 9 | 0 | 1 | 2 | 2 | 2 | 2 | 2 | 2 | 2 | 2 | 2 | 3 | 3 |
|             | Access Control Policy Rule Reason Data Block Type (21) |   |   |   |   |   |   |   |   |   |   |   |   |   |   |   |                       |   |   |   |   |   |   |   |   |   |   |   |   |   |   |   |   |
|             | Access Control Policy Rule Reason Data Block Length    |   |   |   |   |   |   |   |   |   |   |   |   |   |   |   |                       |   |   |   |   |   |   |   |   |   |   |   |   |   |   |   |   |
| Description | Reason   |   |   |   |   |   |   |   |   |   |   |   |   |   |   |   | String Block Type (0) |   |   |   |   |   |   |   |   |   |   |   |   |   |   |   |   |
|             | String Block Type (0), continued                       |   |   |   |   |   |   |   |   |   |   |   |   |   |   |   | String Block Length   |   |   |   |   |   |   |   |   |   |   |   |   |   |   |   |   |
|             | String Block Length, continued                         |   |   |   |   |   |   |   |   |   |   |   |   |   |   |   | Description...        |   |   |   |   |   |   |   |   |   |   |   |   |   |   |   |   |

The following table describes the fields in the Access Control Policy Rule ID metadata block.

**Table 3-35** Access Control Policy Rule Reason Data Block Fields

| Field   | Data Type | Description  |
|---|-----------|--|
| Access Control Policy Rule Reason Data Block Type   | uint32    | Initiates an Access Control Policy Rule Reason data block. This value is always 21.  |
| Access Control Policy Rule Reason Data Block Length | uint32    | Total number of bytes in the Access Control Policy Rule Reason data block, including eight bytes for the Access Control Policy Rule Reason data block type and length fields, plus the number of bytes of data that follows. |
| Reason  | uint16    | The number of the reason for the rule that triggered the event.  |
| String Block Type                                   | uint32    | Initiates a String data block containing the description of the access control policy rule reason. This value is always 0.   |
| String Block Length                                 | uint32    | The number of bytes included in the name String data block, including eight bytes for the block type and header fields plus the number of bytes in the Description field.  |
| Description   | string    | Description of the reason for the rule.  |

## IP Reputation Category Data Block

The eStreamer service uses the IP Reputation Category Data block to contain information about rule reputation categories. This data block has a block type of 22 in series 2.

The following diagram shows the structure of the IP Reputation Category data block.

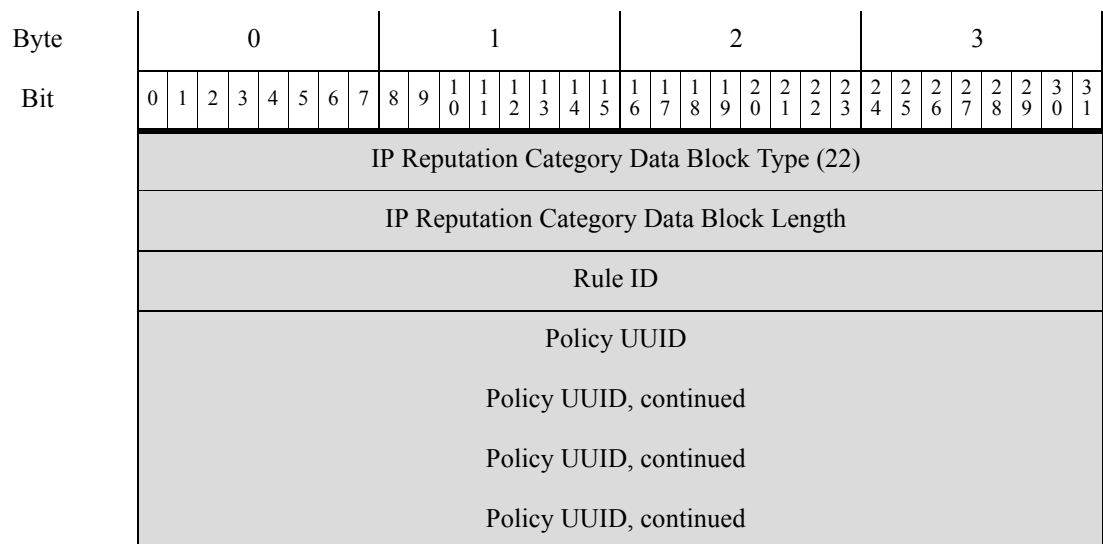

| Byte        | 0                     |   |   |   |   |   |   |   | 1 |   |    |    |    |    |    |    | 2  |    |    |    |    |    |    |    | 3  |    |    |    |    |    |    |    |
|-------------|-----------------------|---|---|---|---|---|---|---|---|---|----|----|----|----|----|----|----|----|----|----|----|----|----|----|----|----|----|----|----|----|----|----|
| Bit         | 0                     | 1 | 2 | 3 | 4 | 5 | 6 | 7 | 8 | 9 | 10 | 11 | 12 | 13 | 14 | 15 | 16 | 17 | 18 | 19 | 20 | 21 | 22 | 23 | 24 | 25 | 26 | 27 | 28 | 29 | 30 | 31 |
| Description | String Block Type (0) |   |   |   |   |   |   |   |   |   |    |    |    |    |    |    |    |    |    |    |    |    |    |    |    |    |    |    |    |    |    |    |
|             | String Block Length   |   |   |   |   |   |   |   |   |   |    |    |    |    |    |    |    |    |    |    |    |    |    |    |    |    |    |    |    |    |    |    |
|             | Category Name...      |   |   |   |   |   |   |   |   |   |    |    |    |    |    |    |    |    |    |    |    |    |    |    |    |    |    |    |    |    |    |    |

The following table describes the fields in the IP Reputation Category Data Block.

**Table 3-36** IP Reputation Category Data Block Fields

| Field                                    | Data Type | Description  |
|--|-----------|--|
| IP Reputation Category Data Block Type   | uint32    | Initiates a IP Reputation Category data block. This value is always 22.  |
| IP Reputation Category Data Block Length | uint32    | Total number of bytes in the IP Reputation Category data block, including eight bytes for the IP Reputation Category data block type and length fields, plus the number of bytes of data that follows. |
| Rule ID                                  | uint32    | Internal identifier for the rule that triggered the event.   |
| Policy UUID                              | uint8[16] | UUID of the policy that triggered the event.   |
| String Block Type                        | uint32    | Initiates a String data block containing the description of the IP Reputation Category. This value is always 0.  |
| String Block Length                      | uint32    | The number of bytes included in the Category Name String data block, including eight bytes for the block type and header fields plus the number of bytes in the Category Name field.                   |
| Category Name                            | string    | Name of the category for the rule.   |

## File Event for 5.3.1+

The file event contains information on files that are sent over the network. This includes the connection information, whether the file is malware, and specific information to identify the file. The file event has a block type of 43 in the series 2 group of blocks. It supersedes block type 38. A security context field has been added.

You request file event records by setting the file event flag—bit 30 in the Request Flags field—in the request message with an event version of 4 and an event code of 111. See [Request Flags, page 2-11](#). If you enable bit 23, an extended event header is included in the record.

The following graphic shows the structure of the File Event data block.

|                                   |   |   |   |   |   |   |   |                   |   |   |    |    |    |    |    |                     |    |    |    |    |    |    |    |                      |    |    |    |    |    |    |    |    |
|-----------------------------------|---|---|---|---|---|---|---|-------------------|---|---|----|----|----|----|----|---------------------|----|----|----|----|----|----|----|----------------------|----|----|----|----|----|----|----|----|
| Byte                              | 0 |   |   |   |   |   |   |                   | 1 |   |    |    |    |    |    |                     | 2  |    |    |    |    |    |    |                      | 3  |    |    |    |    |    |    |    |
| Bit                               | 0 | 1 | 2 | 3 | 4 | 5 | 6 | 7                 | 8 | 9 | 10 | 11 | 12 | 13 | 14 | 15                  | 16 | 17 | 18 | 19 | 20 | 21 | 22 | 23                   | 24 | 25 | 26 | 27 | 28 | 29 | 30 | 31 |
| File Event Block Type (43)        |   |   |   |   |   |   |   |                   |   |   |    |    |    |    |    |                     |    |    |    |    |    |    |    |                      |    |    |    |    |    |    |    |    |
| File Event Block Length           |   |   |   |   |   |   |   |                   |   |   |    |    |    |    |    |                     |    |    |    |    |    |    |    |                      |    |    |    |    |    |    |    |    |
| Device ID                         |   |   |   |   |   |   |   |                   |   |   |    |    |    |    |    |                     |    |    |    |    |    |    |    |                      |    |    |    |    |    |    |    |    |
| Connection Instance               |   |   |   |   |   |   |   |                   |   |   |    |    |    |    |    | Connection Counter  |    |    |    |    |    |    |    |                      |    |    |    |    |    |    |    |    |
| Connection Timestamp              |   |   |   |   |   |   |   |                   |   |   |    |    |    |    |    |                     |    |    |    |    |    |    |    |                      |    |    |    |    |    |    |    |    |
| File Event Timestamp              |   |   |   |   |   |   |   |                   |   |   |    |    |    |    |    |                     |    |    |    |    |    |    |    |                      |    |    |    |    |    |    |    |    |
| Source IP Address                 |   |   |   |   |   |   |   |                   |   |   |    |    |    |    |    |                     |    |    |    |    |    |    |    |                      |    |    |    |    |    |    |    |    |
| Source IP Address, continued      |   |   |   |   |   |   |   |                   |   |   |    |    |    |    |    |                     |    |    |    |    |    |    |    |                      |    |    |    |    |    |    |    |    |
| Source IP Address, continued      |   |   |   |   |   |   |   |                   |   |   |    |    |    |    |    |                     |    |    |    |    |    |    |    |                      |    |    |    |    |    |    |    |    |
| Source IP Address, continued      |   |   |   |   |   |   |   |                   |   |   |    |    |    |    |    |                     |    |    |    |    |    |    |    |                      |    |    |    |    |    |    |    |    |
| Destination IP Address            |   |   |   |   |   |   |   |                   |   |   |    |    |    |    |    |                     |    |    |    |    |    |    |    |                      |    |    |    |    |    |    |    |    |
| Destination IP Address, continued |   |   |   |   |   |   |   |                   |   |   |    |    |    |    |    |                     |    |    |    |    |    |    |    |                      |    |    |    |    |    |    |    |    |
| Destination IP Address, continued |   |   |   |   |   |   |   |                   |   |   |    |    |    |    |    |                     |    |    |    |    |    |    |    |                      |    |    |    |    |    |    |    |    |
| Destination IP Address, continued |   |   |   |   |   |   |   |                   |   |   |    |    |    |    |    |                     |    |    |    |    |    |    |    |                      |    |    |    |    |    |    |    |    |
| Disposition                       |   |   |   |   |   |   |   | SPERO Disposition |   |   |    |    |    |    |    | File Storage Status |    |    |    |    |    |    |    | File Analysis Status |    |    |    |    |    |    |    |    |
| Archive File Status               |   |   |   |   |   |   |   | Threat Score      |   |   |    |    |    |    |    | Action              |    |    |    |    |    |    |    | SHA Hash             |    |    |    |    |    |    |    |    |
| SHA Hash, continued               |   |   |   |   |   |   |   |                   |   |   |    |    |    |    |    |                     |    |    |    |    |    |    |    |                      |    |    |    |    |    |    |    |    |
| SHA Hash, continued               |   |   |   |   |   |   |   |                   |   |   |    |    |    |    |    |                     |    |    |    |    |    |    |    |                      |    |    |    |    |    |    |    |    |
| SHA Hash, continued               |   |   |   |   |   |   |   |                   |   |   |    |    |    |    |    |                     |    |    |    |    |    |    |    |                      |    |    |    |    |    |    |    |    |
| SHA Hash, continued               |   |   |   |   |   |   |   |                   |   |   |    |    |    |    |    |                     |    |    |    |    |    |    |    |                      |    |    |    |    |    |    |    |    |
| SHA Hash, continued               |   |   |   |   |   |   |   |                   |   |   |    |    |    |    |    |                     |    |    |    |    |    |    |    |                      |    |    |    |    |    |    |    |    |
| SHA Hash, continued               |   |   |   |   |   |   |   |                   |   |   |    |    |    |    |    |                     |    |    |    |    |    |    |    |                      |    |    |    |    |    |    |    |    |
| SHA Hash, continued               |   |   |   |   |   |   |   |                   |   |   |    |    |    |    |    |                     |    |    |    |    |    |    |    |                      |    |    |    |    |    |    |    |    |
| SHA Hash, continued               |   |   |   |   |   |   |   |                   |   |   |    |    |    |    |    |                     |    |    |    |    |    |    |    | File Type ID         |    |    |    |    |    |    |    |    |



| Byte      | 0                                     |   |   |   |   |   |   | 1                          |   |   |    |    |    |    | 2                |    |    |    |    |    |    | 3            |    |    |    |    |    |    |                       |    |    |    |  |  |  |
|-----------|---------------------------------------|---|---|---|---|---|---|----------------------------|---|---|----|----|----|----|------------------|----|----|----|----|----|----|--------------|----|----|----|----|----|----|-----------------------|----|----|----|--|--|--|
| Bit       | 0                                     | 1 | 2 | 3 | 4 | 5 | 6 | 7                          | 8 | 9 | 10 | 11 | 12 | 13 | 14               | 15 | 16 | 17 | 18 | 19 | 20 | 21           | 22 | 23 | 24 | 25 | 26 | 27 | 28                    | 29 | 30 | 31 |  |  |  |
| File Name | File Type ID, cont.                   |   |   |   |   |   |   |                            |   |   |    |    |    |    |                  |    |    |    |    |    |    |              |    |    |    |    |    |    | String Block Type (0) |    |    |    |  |  |  |
|           | String Block Type (0), cont.          |   |   |   |   |   |   |                            |   |   |    |    |    |    |                  |    |    |    |    |    |    |              |    |    |    |    |    |    | String Block Length   |    |    |    |  |  |  |
|           | String Block Length, cont.            |   |   |   |   |   |   |                            |   |   |    |    |    |    |                  |    |    |    |    |    |    |              |    |    |    |    |    |    | File Name...          |    |    |    |  |  |  |
|           | File Size<br>File Size, continued     |   |   |   |   |   |   |                            |   |   |    |    |    |    |                  |    |    |    |    |    |    |              |    |    |    |    |    |    |                       |    |    |    |  |  |  |
|           | Direction                             |   |   |   |   |   |   | Application ID             |   |   |    |    |    |    |                  |    |    |    |    |    |    |              |    |    |    |    |    |    |                       |    |    |    |  |  |  |
|           | App ID, cont.                         |   |   |   |   |   |   | User ID                    |   |   |    |    |    |    |                  |    |    |    |    |    |    |              |    |    |    |    |    |    |                       |    |    |    |  |  |  |
| URI       | User ID, cont.                        |   |   |   |   |   |   | String Block Type (0)      |   |   |    |    |    |    |                  |    |    |    |    |    |    |              |    |    |    |    |    |    |                       |    |    |    |  |  |  |
|           | String Block Type (0), cont.          |   |   |   |   |   |   | String Block Length        |   |   |    |    |    |    |                  |    |    |    |    |    |    |              |    |    |    |    |    |    |                       |    |    |    |  |  |  |
|           | String Block Length, cont.            |   |   |   |   |   |   | URI...                     |   |   |    |    |    |    |                  |    |    |    |    |    |    |              |    |    |    |    |    |    |                       |    |    |    |  |  |  |
| Signature | String Block Type (0)                 |   |   |   |   |   |   |                            |   |   |    |    |    |    |                  |    |    |    |    |    |    |              |    |    |    |    |    |    |                       |    |    |    |  |  |  |
|           | String Block Length                   |   |   |   |   |   |   |                            |   |   |    |    |    |    |                  |    |    |    |    |    |    |              |    |    |    |    |    |    |                       |    |    |    |  |  |  |
|           | Signature...                          |   |   |   |   |   |   |                            |   |   |    |    |    |    |                  |    |    |    |    |    |    |              |    |    |    |    |    |    |                       |    |    |    |  |  |  |
|           | Source Port                           |   |   |   |   |   |   |                            |   |   |    |    |    |    | Destination Port |    |    |    |    |    |    |              |    |    |    |    |    |    |                       |    |    |    |  |  |  |
|           | Protocol                              |   |   |   |   |   |   | Access Control Policy UUID |   |   |    |    |    |    |                  |    |    |    |    |    |    |              |    |    |    |    |    |    |                       |    |    |    |  |  |  |
|           | Access Control Policy UUID, continued |   |   |   |   |   |   |                            |   |   |    |    |    |    |                  |    |    |    |    |    |    |              |    |    |    |    |    |    |                       |    |    |    |  |  |  |
|           | Access Control Policy UUID, continued |   |   |   |   |   |   |                            |   |   |    |    |    |    |                  |    |    |    |    |    |    |              |    |    |    |    |    |    |                       |    |    |    |  |  |  |
|           | Access Control Policy UUID, continued |   |   |   |   |   |   |                            |   |   |    |    |    |    |                  |    |    |    |    |    |    |              |    |    |    |    |    |    |                       |    |    |    |  |  |  |
|           | AC Pol UUID, cont.                    |   |   |   |   |   |   | Source Country             |   |   |    |    |    |    |                  |    |    |    |    |    |    | Dst. Country |    |    |    |    |    |    |                       |    |    |    |  |  |  |
|           | Dst. Country, cont.                   |   |   |   |   |   |   | Web Application ID         |   |   |    |    |    |    |                  |    |    |    |    |    |    |              |    |    |    |    |    |    |                       |    |    |    |  |  |  |
|           | Web App. ID, cont.                    |   |   |   |   |   |   | Client Application ID      |   |   |    |    |    |    |                  |    |    |    |    |    |    |              |    |    |    |    |    |    |                       |    |    |    |  |  |  |
|           | Client App. ID, cont.                 |   |   |   |   |   |   | Security Context           |   |   |    |    |    |    |                  |    |    |    |    |    |    |              |    |    |    |    |    |    |                       |    |    |    |  |  |  |
|           | Security Context, continued           |   |   |   |   |   |   |                            |   |   |    |    |    |    |                  |    |    |    |    |    |    |              |    |    |    |    |    |    |                       |    |    |    |  |  |  |

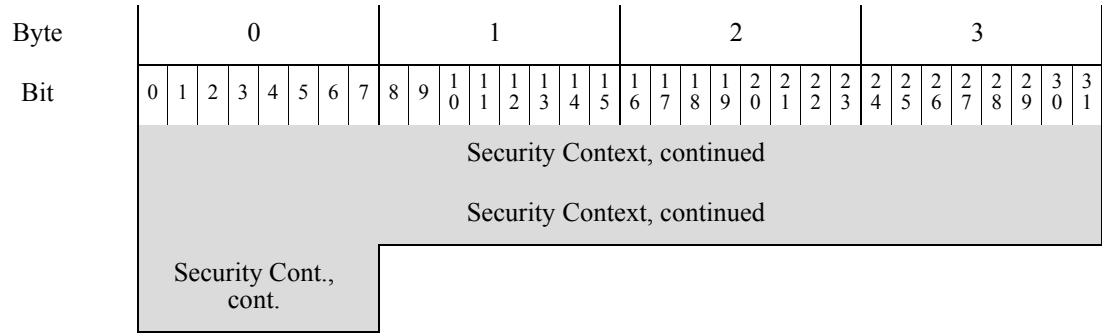

The following table describes the fields in the file event data block.

**Table 3-37 File Event Data Block for 5.3.1+ Fields**

| Field                   | Data Type | Description   |
|-------------------------|-----------|---|
| File Event Block Type   | uint32    | Initiates whether file event data block. This value is always 43.   |
| File Event Block Length | uint32    | Total number of bytes in the file event block, including eight bytes for the file event block type and length fields, plus the number of bytes of data that follows.  |
| Device ID               | uint32    | ID for the device that generated the event.   |
| Connection Instance     | uint16    | Snort instance on the device that generated the event. Used to link the event with a connection or intrusion event.   |
| Connection Counter      | uint16    | Value used to distinguish between connection events that happen during the same second.   |
| Connection Timestamp    | uint32    | UNIX timestamp (seconds since 01/01/1970) of the associated connection event.   |
| File Event Timestamp    | uint32    | UNIX timestamp (seconds since 01/01/1970) of when the file type is identified and the file event generated.   |
| Source IP Address       | uint8[16] | IPv4 or IPv6 address for the source of the connection.  |
| Destination IP Address  | uint8[16] | IPv4 or IPv6 address for the destination of the connection.   |
| Disposition             | uint8     | The malware status of the file. Possible values include: <ul style="list-style-type: none"> <li>• 1 - CLEAN The file is clean and does not contain malware.</li> <li>• 2 - UNKNOWN It is unknown whether the file contains malware.</li> <li>• 3 - MALWARE The file contains malware.</li> <li>• 4 - UNAVAILABLE The software was unable to send a request to the Cisco cloud for a disposition, or the Cisco cloud services did not respond to the request.</li> <li>• 5 - CUSTOM SIGNATURE The file matches a user-defined hash, and is treated in a fashion designated by the user.</li> </ul> |

Table 3-37 File Event Data Block for 5.3.1+ Fields (continued)

| Field               | Data Type | Description   |
|---------------------|-----------|---|
| SPERO Disposition   | uint8     | Indicates whether the SPERO signature was used in file analysis. If the value is 1, 2, or 3, SPERO analysis was used. If there is any other value SPERO analysis was not used.  |
| File Storage Status | uint8     | The storage status of the file. Possible values are: <ul style="list-style-type: none"><li>• 1 - File Stored</li><li>• 2 - File Stored</li><li>• 3 - Unable to Store File</li><li>• 4 - Unable to Store File</li><li>• 5 - Unable to Store File</li><li>• 6 - Unable to Store File</li><li>• 7 - Unable to Store File</li><li>• 8 - File Size is Too Large</li><li>• 9 - File Size is Too Small</li><li>• 10 - Unable to Store File</li><li>• 11 - File Not Stored, Disposition Unavailable</li></ul> |

Table 3-37 File Event Data Block for 5.3.1+ Fields (continued)

| Field                | Data Type | Description   |
|----------------------|-----------|---|
| File Analysis Status | uint8     | Indicates whether the file was sent for dynamic analysis. Possible values are: <ul style="list-style-type: none"> <li>• 1 - Sent for Analysis</li> <li>• 2 - Sent for Analysis</li> <li>• 4 - Sent for Analysis</li> <li>• 5 - Failed to Send</li> <li>• 6 - Failed to Send</li> <li>• 7 - Failed to Send</li> <li>• 8 - Failed to Send</li> <li>• 9 - File Size is Too Small</li> <li>• 10 - File Size is Too Large</li> <li>• 11 - Sent for Analysis</li> <li>• 12 - Analysis Complete</li> <li>• 13 - Failure (Network Issue)</li> <li>• 14 - Failure (Rate Limit)</li> <li>• 15 - Failure (File Too Large)</li> <li>• 16 - Failure (File Read Error)</li> <li>• 17 - Failure (Internal Library Error)</li> <li>• 19 - File Not Sent, Disposition Unavailable</li> <li>• 20 - Failure (Cannot Run File)</li> <li>• 21 - Failure (Analysis Timeout)</li> <li>• 22 - Sent for Analysis</li> <li>• 23 - File Not Supported</li> </ul> |
| Archive File Status  | uint8     | This is always 0.   |
| Threat Score         | uint8     | A numeric value from 0 to 100 based on the potentially malicious behaviors observed during dynamic analysis.  |
| Action               | uint8     | The action taken on the file based on the file type. Can have the following values: <ul style="list-style-type: none"> <li>• 1 - Detect</li> <li>• 2 - Block</li> <li>• 3 - Malware Cloud Lookup</li> <li>• 4 - Malware Block</li> <li>• 5 - Malware Whitelist</li> <li>• 6 - Cloud Lookup Timeout</li> <li>• 7 - Custom Detection</li> <li>• 8 - Custom Detection Block</li> </ul>   |

Table 3-37 File Event Data Block for 5.3.1+ Fields (continued)

| Field                      | Data Type | Description  |
|----------------------------|-----------|--|
| SHA Hash                   | uint8[32] | SHA-256 hash of the file, in binary format.  |
| File Type ID               | uint32    | ID number that maps to the file type. The meaning of this field is transmitted in the metadata with this event. See <a href="#">FireAMP File Type Metadata, page 3-35</a> for more information.  |
| File Name                  | string    | Name of the file.  |
| File Size                  | uint64    | Size of the file in bytes.   |
| Direction                  | uint8     | Value that indicates whether the file was uploaded or downloaded. Can have the following values: <ul style="list-style-type: none"> <li>• 1 - Download</li> <li>• 2 - Upload</li> </ul> Currently the value depends on the protocol (for example, if the connection is HTTP it is a download). |
| Application ID             | uint32    | ID number that maps to the application using the file transfer.  |
| User ID                    | uint32    | ID number for the user logged into the destination host, as identified by the system.  |
| URI                        | string    | Uniform Resource Identifier (URI) of the connection.   |
| Signature                  | string    | SHA-256 hash of the file, in string format.  |
| Source Port                | uint16    | Port number for the source of the connection.  |
| Destination Port           | uint16    | Port number for the destination of the connection.   |
| Protocol                   | uint8     | IANA protocol number specified by the user. For example: <ul style="list-style-type: none"> <li>• 1 - ICMP</li> <li>• 4 - IP</li> <li>• 6 - TCP</li> <li>• 17 - UDP</li> </ul> This is currently only TCP.   |
| Access Control Policy UUID | uint8[16] | Unique identifier for the access control policy that triggered the event.  |
| Source Country             | uint16    | Code for the country of the source host.   |
| Destination Country        | uint16    | Code for the country of the destination host.  |
| Web Application ID         | uint32    | The internal identification number for the web application, if applicable.   |
| Client Application ID      | uint32    | The internal identification number for the client application, if applicable.  |
| Security Context           | uint8(16) | ID number for the security context (virtual firewall) that the traffic passed through. Note that the system only populates this field for ASA FirePOWER devices in multi-context mode.   |

## Malware Event Data Block 5.3.1+

The eStreamer service uses the malware event data block to store information on malware events. These events contain information on malware detected or quarantined within a cloud, the detection method, and hosts and users affected by the malware. The malware event data block has a block type of 44 in the series 2 group of blocks. It supersedes block 35. You request the event as part of the malware event record by setting the malware event flag—bit 30 in the request flags field—in the request message with an event version of 5 and an event code of 101.

The following graphic shows the structure of the malware event data block:

| Byte           | 0                             |   |   |   |   |   |   |   | 1                     |   |    |    |    |    |    |    | 2  |    |    |    |    |    |    |    | 3  |    |    |    |    |    |    |    |
|----------------|-------------------------------|---|---|---|---|---|---|---|-----------------------|---|----|----|----|----|----|----|----|----|----|----|----|----|----|----|----|----|----|----|----|----|----|----|
| Bit            | 0                             | 1 | 2 | 3 | 4 | 5 | 6 | 7 | 8                     | 9 | 10 | 11 | 12 | 13 | 14 | 15 | 16 | 17 | 18 | 19 | 20 | 21 | 22 | 23 | 24 | 25 | 26 | 27 | 28 | 29 | 30 | 31 |
|                | Malware Event Block Type (44) |   |   |   |   |   |   |   |                       |   |    |    |    |    |    |    |    |    |    |    |    |    |    |    |    |    |    |    |    |    |    |    |
|                | Malware Event Block Length    |   |   |   |   |   |   |   |                       |   |    |    |    |    |    |    |    |    |    |    |    |    |    |    |    |    |    |    |    |    |    |    |
|                | Agent UUID                    |   |   |   |   |   |   |   |                       |   |    |    |    |    |    |    |    |    |    |    |    |    |    |    |    |    |    |    |    |    |    |    |
|                | Agent UUID, continued         |   |   |   |   |   |   |   |                       |   |    |    |    |    |    |    |    |    |    |    |    |    |    |    |    |    |    |    |    |    |    |    |
|                | Agent UUID, continued         |   |   |   |   |   |   |   |                       |   |    |    |    |    |    |    |    |    |    |    |    |    |    |    |    |    |    |    |    |    |    |    |
|                | Agent UUID, continued         |   |   |   |   |   |   |   |                       |   |    |    |    |    |    |    |    |    |    |    |    |    |    |    |    |    |    |    |    |    |    |    |
|                | Cloud UUID                    |   |   |   |   |   |   |   |                       |   |    |    |    |    |    |    |    |    |    |    |    |    |    |    |    |    |    |    |    |    |    |    |
|                | Cloud UUID, continued         |   |   |   |   |   |   |   |                       |   |    |    |    |    |    |    |    |    |    |    |    |    |    |    |    |    |    |    |    |    |    |    |
|                | Cloud UUID, continued         |   |   |   |   |   |   |   |                       |   |    |    |    |    |    |    |    |    |    |    |    |    |    |    |    |    |    |    |    |    |    |    |
|                | Cloud UUID, continued         |   |   |   |   |   |   |   |                       |   |    |    |    |    |    |    |    |    |    |    |    |    |    |    |    |    |    |    |    |    |    |    |
|                | Malware Event Timestamp       |   |   |   |   |   |   |   |                       |   |    |    |    |    |    |    |    |    |    |    |    |    |    |    |    |    |    |    |    |    |    |    |
|                | Event Type ID                 |   |   |   |   |   |   |   |                       |   |    |    |    |    |    |    |    |    |    |    |    |    |    |    |    |    |    |    |    |    |    |    |
|                | Event Subtype ID              |   |   |   |   |   |   |   |                       |   |    |    |    |    |    |    |    |    |    |    |    |    |    |    |    |    |    |    |    |    |    |    |
| Detection Name | Detector ID                   |   |   |   |   |   |   |   | String Block Type (0) |   |    |    |    |    |    |    |    |    |    |    |    |    |    |    |    |    |    |    |    |    |    |    |
|                | String Block Type (0), cont.  |   |   |   |   |   |   |   | String Block Length   |   |    |    |    |    |    |    |    |    |    |    |    |    |    |    |    |    |    |    |    |    |    |    |
|                | String Block Length, cont.    |   |   |   |   |   |   |   | Detection Name...     |   |    |    |    |    |    |    |    |    |    |    |    |    |    |    |    |    |    |    |    |    |    |    |
| User           | String Block Type (0)         |   |   |   |   |   |   |   |                       |   |    |    |    |    |    |    |    |    |    |    |    |    |    |    |    |    |    |    |    |    |    |    |
|                | String Block Length           |   |   |   |   |   |   |   |                       |   |    |    |    |    |    |    |    |    |    |    |    |    |    |    |    |    |    |    |    |    |    |    |
|                | User...                       |   |   |   |   |   |   |   |                       |   |    |    |    |    |    |    |    |    |    |    |    |    |    |    |    |    |    |    |    |    |    |    |

| Byte                 | 0                          |   |   |   |   |   |   |   | 1                 |   |    |    |    |    |    |    | 2                  |    |    |    |    |    |    |    | 3  |    |    |    |    |    |    |    |
|----------------------|----------------------------|---|---|---|---|---|---|---|-------------------|---|----|----|----|----|----|----|--------------------|----|----|----|----|----|----|----|----|----|----|----|----|----|----|----|
|                      | 0                          | 1 | 2 | 3 | 4 | 5 | 6 | 7 | 8                 | 9 | 10 | 11 | 12 | 13 | 14 | 15 | 16                 | 17 | 18 | 19 | 20 | 21 | 22 | 23 | 24 | 25 | 26 | 27 | 28 | 29 | 30 | 31 |
| File Name            | String Block Type (0)      |   |   |   |   |   |   |   |                   |   |    |    |    |    |    |    |                    |    |    |    |    |    |    |    |    |    |    |    |    |    |    |    |
|                      | String Block Length        |   |   |   |   |   |   |   |                   |   |    |    |    |    |    |    |                    |    |    |    |    |    |    |    |    |    |    |    |    |    |    |    |
|                      | File Name...               |   |   |   |   |   |   |   |                   |   |    |    |    |    |    |    |                    |    |    |    |    |    |    |    |    |    |    |    |    |    |    |    |
| File Path            | String Block Type (0)      |   |   |   |   |   |   |   |                   |   |    |    |    |    |    |    |                    |    |    |    |    |    |    |    |    |    |    |    |    |    |    |    |
|                      | String Block Length        |   |   |   |   |   |   |   |                   |   |    |    |    |    |    |    |                    |    |    |    |    |    |    |    |    |    |    |    |    |    |    |    |
|                      | File Path...               |   |   |   |   |   |   |   |                   |   |    |    |    |    |    |    |                    |    |    |    |    |    |    |    |    |    |    |    |    |    |    |    |
| File SHA Hash        | String Block Type (0)      |   |   |   |   |   |   |   |                   |   |    |    |    |    |    |    |                    |    |    |    |    |    |    |    |    |    |    |    |    |    |    |    |
|                      | String Block Length        |   |   |   |   |   |   |   |                   |   |    |    |    |    |    |    |                    |    |    |    |    |    |    |    |    |    |    |    |    |    |    |    |
|                      | File SHA Hash...           |   |   |   |   |   |   |   |                   |   |    |    |    |    |    |    |                    |    |    |    |    |    |    |    |    |    |    |    |    |    |    |    |
|                      | File Size                  |   |   |   |   |   |   |   |                   |   |    |    |    |    |    |    |                    |    |    |    |    |    |    |    |    |    |    |    |    |    |    |    |
|                      | File Type                  |   |   |   |   |   |   |   |                   |   |    |    |    |    |    |    |                    |    |    |    |    |    |    |    |    |    |    |    |    |    |    |    |
|                      | File Timestamp             |   |   |   |   |   |   |   |                   |   |    |    |    |    |    |    |                    |    |    |    |    |    |    |    |    |    |    |    |    |    |    |    |
| Parent File Name     | String Block Type (0)      |   |   |   |   |   |   |   |                   |   |    |    |    |    |    |    |                    |    |    |    |    |    |    |    |    |    |    |    |    |    |    |    |
|                      | String Block Length        |   |   |   |   |   |   |   |                   |   |    |    |    |    |    |    |                    |    |    |    |    |    |    |    |    |    |    |    |    |    |    |    |
|                      | Parent File Name...        |   |   |   |   |   |   |   |                   |   |    |    |    |    |    |    |                    |    |    |    |    |    |    |    |    |    |    |    |    |    |    |    |
| Parent File SHA Hash | String Block Type (0)      |   |   |   |   |   |   |   |                   |   |    |    |    |    |    |    |                    |    |    |    |    |    |    |    |    |    |    |    |    |    |    |    |
|                      | String Block Length        |   |   |   |   |   |   |   |                   |   |    |    |    |    |    |    |                    |    |    |    |    |    |    |    |    |    |    |    |    |    |    |    |
|                      | Parent File SHA Hash...    |   |   |   |   |   |   |   |                   |   |    |    |    |    |    |    |                    |    |    |    |    |    |    |    |    |    |    |    |    |    |    |    |
| Event Description    | String Block Type (0)      |   |   |   |   |   |   |   |                   |   |    |    |    |    |    |    |                    |    |    |    |    |    |    |    |    |    |    |    |    |    |    |    |
|                      | String Block Length        |   |   |   |   |   |   |   |                   |   |    |    |    |    |    |    |                    |    |    |    |    |    |    |    |    |    |    |    |    |    |    |    |
|                      | Event Description...       |   |   |   |   |   |   |   |                   |   |    |    |    |    |    |    |                    |    |    |    |    |    |    |    |    |    |    |    |    |    |    |    |
|                      | Device ID                  |   |   |   |   |   |   |   |                   |   |    |    |    |    |    |    |                    |    |    |    |    |    |    |    |    |    |    |    |    |    |    |    |
|                      | Connection Instance        |   |   |   |   |   |   |   |                   |   |    |    |    |    |    |    | Connection Counter |    |    |    |    |    |    |    |    |    |    |    |    |    |    |    |
|                      | Connection Event Timestamp |   |   |   |   |   |   |   |                   |   |    |    |    |    |    |    |                    |    |    |    |    |    |    |    |    |    |    |    |    |    |    |    |
|                      | Direction                  |   |   |   |   |   |   |   | Source IP Address |   |    |    |    |    |    |    |                    |    |    |    |    |    |    |    |    |    |    |    |    |    |    |    |

| Byte                        | 0                                     |   |   |   |   |   |   |                  | 1                          |   |    |    |    |    |    |                     | 2                  |    |    |    |    |    |    |            | 3                   |    |    |    |    |    |    |    |
|-----------------------------|---------------------------------------|---|---|---|---|---|---|------------------|----------------------------|---|----|----|----|----|----|---------------------|--------------------|----|----|----|----|----|----|------------|---------------------|----|----|----|----|----|----|----|
| Bit                         | 0                                     | 1 | 2 | 3 | 4 | 5 | 6 | 7                | 8                          | 9 | 10 | 11 | 12 | 13 | 14 | 15                  | 16                 | 17 | 18 | 19 | 20 | 21 | 22 | 23         | 24                  | 25 | 26 | 27 | 28 | 29 | 30 | 31 |
|                             | Source IP Address, continued          |   |   |   |   |   |   |                  |                            |   |    |    |    |    |    |                     |                    |    |    |    |    |    |    |            |                     |    |    |    |    |    |    |    |
|                             | Source IP Address, continued          |   |   |   |   |   |   |                  |                            |   |    |    |    |    |    |                     |                    |    |    |    |    |    |    |            |                     |    |    |    |    |    |    |    |
|                             | Source IP Address, continued          |   |   |   |   |   |   |                  |                            |   |    |    |    |    |    |                     |                    |    |    |    |    |    |    |            |                     |    |    |    |    |    |    |    |
|                             | Source IP, cont.                      |   |   |   |   |   |   |                  | Destination IP Address     |   |    |    |    |    |    |                     |                    |    |    |    |    |    |    |            |                     |    |    |    |    |    |    |    |
|                             | Destination IP Address, continued     |   |   |   |   |   |   |                  |                            |   |    |    |    |    |    |                     |                    |    |    |    |    |    |    |            |                     |    |    |    |    |    |    |    |
|                             | Destination IP Address, continued     |   |   |   |   |   |   |                  |                            |   |    |    |    |    |    |                     |                    |    |    |    |    |    |    |            |                     |    |    |    |    |    |    |    |
|                             | Destination IP Address, continued     |   |   |   |   |   |   |                  |                            |   |    |    |    |    |    |                     |                    |    |    |    |    |    |    |            |                     |    |    |    |    |    |    |    |
|                             | Destination IP, cont                  |   |   |   |   |   |   |                  | Application ID             |   |    |    |    |    |    |                     |                    |    |    |    |    |    |    |            |                     |    |    |    |    |    |    |    |
|                             | App. ID, cont.                        |   |   |   |   |   |   |                  | User ID                    |   |    |    |    |    |    |                     |                    |    |    |    |    |    |    |            |                     |    |    |    |    |    |    |    |
|                             | User ID, cont.                        |   |   |   |   |   |   |                  | Access Control Policy UUID |   |    |    |    |    |    |                     |                    |    |    |    |    |    |    |            |                     |    |    |    |    |    |    |    |
|                             | Access Control Policy UUID, continued |   |   |   |   |   |   |                  |                            |   |    |    |    |    |    |                     |                    |    |    |    |    |    |    |            |                     |    |    |    |    |    |    |    |
|                             | Access Control Policy UUID, continued |   |   |   |   |   |   |                  |                            |   |    |    |    |    |    |                     |                    |    |    |    |    |    |    |            |                     |    |    |    |    |    |    |    |
|                             | Access Control Policy UUID, continued |   |   |   |   |   |   |                  |                            |   |    |    |    |    |    |                     |                    |    |    |    |    |    |    |            |                     |    |    |    |    |    |    |    |
| URI                         | AC Pol UUID, cont.                    |   |   |   |   |   |   |                  | Disposition                |   |    |    |    |    |    |                     | Retro. Disposition |    |    |    |    |    |    |            | Str. Block Type (0) |    |    |    |    |    |    |    |
|                             | String Block Type (0), continued      |   |   |   |   |   |   |                  |                            |   |    |    |    |    |    |                     |                    |    |    |    |    |    |    |            | String Block Length |    |    |    |    |    |    |    |
|                             | String Block Length, continued        |   |   |   |   |   |   |                  |                            |   |    |    |    |    |    |                     |                    |    |    |    |    |    |    |            | URI...              |    |    |    |    |    |    |    |
|                             | Source Port                           |   |   |   |   |   |   |                  |                            |   |    |    |    |    |    |                     | Destination Port   |    |    |    |    |    |    |            |                     |    |    |    |    |    |    |    |
| Source Country              |                                       |   |   |   |   |   |   |                  |                            |   |    |    |    |    |    | Destination Country |                    |    |    |    |    |    |    |            |                     |    |    |    |    |    |    |    |
| Web Application ID          |                                       |   |   |   |   |   |   |                  |                            |   |    |    |    |    |    |                     |                    |    |    |    |    |    |    |            |                     |    |    |    |    |    |    |    |
| Client Application ID       |                                       |   |   |   |   |   |   |                  |                            |   |    |    |    |    |    |                     |                    |    |    |    |    |    |    |            |                     |    |    |    |    |    |    |    |
| Action                      |                                       |   |   |   |   |   |   | Protocol         |                            |   |    |    |    |    |    | Threat Score        |                    |    |    |    |    |    |    | IOC Number |                     |    |    |    |    |    |    |    |
| IOC Number, cont.           |                                       |   |   |   |   |   |   | Security Context |                            |   |    |    |    |    |    |                     |                    |    |    |    |    |    |    |            |                     |    |    |    |    |    |    |    |
| Security Context, continued |                                       |   |   |   |   |   |   |                  |                            |   |    |    |    |    |    |                     |                    |    |    |    |    |    |    |            |                     |    |    |    |    |    |    |    |
| Security Context, continued |                                       |   |   |   |   |   |   |                  |                            |   |    |    |    |    |    |                     |                    |    |    |    |    |    |    |            |                     |    |    |    |    |    |    |    |



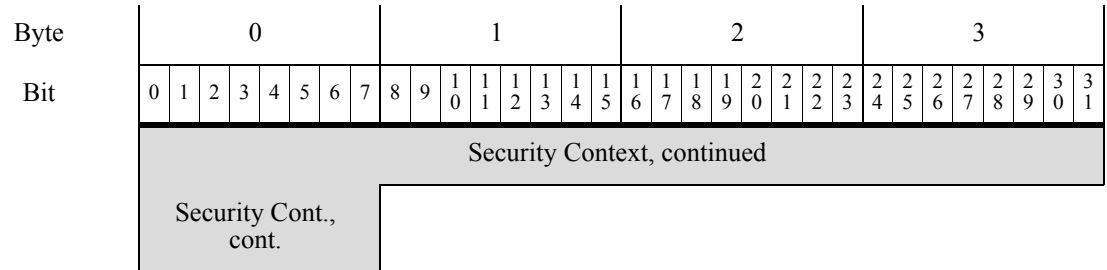

The following table describes the fields in the malware event data block.

**Table 3-38** Malware Event Data Block for 5.3.1+ Fields

| Field                      | Data Type | Description  |
|----------------------------|-----------|--|
| Malware Event Block Type   | uint32    | Initiates a malware event data block. This value is always 44.   |
| Malware Event Block Length | uint32    | Total number of bytes in the malware event data block, including eight bytes for the malware event block type and length fields, plus the number of bytes of data that follows.        |
| Agent UUID                 | uint8[16] | The internal unique ID of the FireAMP agent reporting the malware event.   |
| Cloud UUID                 | uint8[16] | The internal unique ID of the Collective Security Intelligence Cloud from which the malware event originated.  |
| Malware Event Timestamp    | uint32    | The malware event generation timestamp.  |
| Event Type ID              | uint32    | The internal ID of the malware event type.   |
| Event Subtype ID           | uint32    | The internal ID of the action that led to malware detection.   |
| Detector ID                | uint8     | The internal ID of the detection technology that detected the malware.   |
| String Block Type          | uint32    | Initiates a String data block containing the detection name. This value is always 0.   |
| String Block Length        | uint32    | The number of bytes included in the Detection Name String data block, including eight bytes for the block type and header fields plus the number of bytes in the Detection Name field. |
| Detection Name             | string    | The name of the detected or quarantined malware.   |
| String Block Type          | uint32    | Initiates a String data block containing the username. This value is always 0.   |
| String Block Length        | uint32    | The number of bytes included in the User String data block, including eight bytes for the block type and header fields plus the number of bytes in the User field.                     |
| User                       | string    | The user of the computer where the Cisco Agent is installed and where the malware event occurred. Note that these users are not tied to user discovery.                                |

Table 3-38 Malware Event Data Block for 5.3.1+ Fields (continued)

| Field               | Data Type | Description  |
|---------------------|-----------|--|
| String Block Type   | uint32    | Initiates a String data block containing the file name. This value is always 0.  |
| String Block Length | uint32    | The number of bytes included in the File Name String data block, including eight bytes for the block type and header fields plus the number of bytes in the File Name field.                                 |
| File Name           | string    | The name of the detected or quarantined file.  |
| String Block Type   | uint32    | Initiates a String data block containing the file path. This value is always 0.  |
| String Block Length | uint32    | The number of bytes included in the File Path String data block, including eight bytes for the block type and header fields plus the number of bytes in the File Path field.                                 |
| File Path           | string    | The file path, not including the file name, of the detected or quarantined file.   |
| String Block Type   | uint32    | Initiates a String data block containing the file SHA hash. This value is always 0.  |
| String Block Length | uint32    | The number of bytes included in the File SHA Hash String data block, including eight bytes for the block type and header fields plus the number of bytes in the File SHA Hash field.                         |
| File SHA Hash       | string    | The rendered string of the SHA-256 hash value of the detected or quarantined file.   |
| File Size           | uint32    | The size in bytes of the detected or quarantined file.   |
| File Type           | uint32    | The file type of the detected or quarantined file. The meaning of this field is transmitted in the metadata with this event. See <a href="#">FireAMP File Type Metadata, page 3-35</a> for more information. |
| File Timestamp      | uint32    | UNIX timestamp (seconds since 01/01/1970) of the creation of the detected or quarantined file.   |
| String Block Type   | uint32    | Initiates a String data block containing the parent file name. This value is always 0.   |
| String Block Length | uint32    | The number of bytes included in the Parent File Name String data block, including eight bytes for the block type and header fields plus the number of bytes in the Parent File Name field.                   |
| Parent File Name    | string    | The name of the file accessing the detected or quarantined file when detection occurred.   |
| String Block Type   | uint32    | Initiates a String data block containing the parent file SHA hash. This value is always 0.   |
| String Block Length | uint32    | The number of bytes included in the Parent File SHA Hash String data block, including eight bytes for the block type and header fields plus the number of bytes in the Parent File SHA Hash field.           |

Table 3-38 Malware Event Data Block for 5.3.1+ Fields (continued)

| Field                      | Data Type | Description   |
|----------------------------|-----------|---|
| Parent File SHA Hash       | string    | The SHA-256 hash value of the parent file accessing the detected or quarantined file when detection occurred.   |
| String Block Type          | uint32    | Initiates a String data block containing the event description. This value is always 0.   |
| String Block Length        | uint32    | The number of bytes included in the Event Description String data block, including eight bytes for the block type and header fields plus the number of bytes in the Event Description field.  |
| Event Description          | string    | The additional event information associated with the event type.  |
| Device ID                  | uint32    | ID for the device that generated the event.   |
| Connection Instance        | uint16    | Snort instance on the device that generated the event. Used to link the event with a connection or IDS event.   |
| Connection Counter         | uint16    | Value used to distinguish between connection events that happen during the same second.   |
| Connection Event Timestamp | uint32    | Timestamp of the connection event.  |
| Direction                  | uint8     | Indicates whether the file was uploaded or downloaded. Can have the following values: <ul style="list-style-type: none"> <li>• 1 - Download</li> <li>• 2 - Upload</li> </ul> Currently the value depends on the protocol (for example, if the connection is HTTP it is a download). |
| Source IP Address          | uint8[16] | IPv4 or IPv6 address for the source of the connection.  |
| Destination IP Address     | uint8[16] | IPv4 or IPv6 address for the destination of the connection.   |
| Application ID             | uint32    | ID number that maps to the application using the file transfer.   |
| User ID                    | uint32    | Identification number for the user logged into the destination host, as identified by the system.   |
| Access Control Policy UUID | uint8[16] | Identification number that acts as a unique identifier for the access control policy that triggered the event.  |

Table 3-38 Malware Event Data Block for 5.3.1+ Fields (continued)

| Field                     | Data Type | Description   |
|---------------------------|-----------|---|
| Disposition               | uint8     | The malware status of the file. Possible values include: <ul style="list-style-type: none"> <li>• 1 - CLEAN The file is clean and does not contain malware.</li> <li>• 2 - UNKNOWN It is unknown whether the file contains malware.</li> <li>• 3 - MALWARE The file contains malware.</li> <li>• 4 - UNAVAILABLE The software was unable to send a request to the Cisco cloud for a disposition, or the Cisco cloud services did not respond to the request.</li> <li>• 5 - CUSTOM SIGNATURE The file matches a user-defined hash, and is treated in a fashion designated by the user.</li> </ul> |
| Retrospective Disposition | uint8     | Disposition of the file if the disposition is updated. If the disposition is not updated, this field contains the same value as the Disposition field. The possible values are the same as the Disposition field.   |
| String Block Type         | uint32    | Initiates a String data block containing the URI. This value is always 0.   |
| String Block Length       | uint32    | The number of bytes included in the URI data block, including eight bytes for the block type and header fields plus the number of bytes in the URI field.   |
| URI                       | string    | URI of the connection.  |
| Source Port               | uint16    | Port number for the source of the connection.   |
| Destination Port          | uint16    | Port number for the destination of the connection.  |
| Source Country            | uint16    | Code for the country of the source host.  |
| Destination Country       | uint 16   | Code for the country of the destination host.   |
| Web Application ID        | uint32    | The internal identification number of the detected web application, if applicable.  |
| Client Application ID     | uint32    | The internal identification number of the detected client application, if applicable.   |
| Action                    | uint8     | The action taken on the file based on the file type. Can have the following values: <ul style="list-style-type: none"> <li>• 1 - Detect</li> <li>• 2 - Block</li> <li>• 3 - Malware Cloud Lookup</li> <li>• 4 - Malware Block</li> <li>• 5 - Malware Whitelist</li> <li>• 6 - Cloud Lookup Timeout</li> <li>• 7 - Custom Detection</li> <li>• 8 - Custom Detection Block</li> </ul>   |

Table 3-38 Malware Event Data Block for 5.3.1+ Fields (continued)

| Field            | Data Type | Description  |
|------------------|-----------|--|
| Protocol         | uint8     | IANA protocol number specified by the user. For example: <ul style="list-style-type: none"> <li>• 1 - ICMP</li> <li>• 4 - IP</li> <li>• 6 - TCP</li> <li>• 17 - UDP</li> </ul> This is currently only TCP. |
| Threat Score     | uint8     | A numeric value from 0 to 100 based on the potentially malicious behaviors observed during dynamic analysis.   |
| IOC Number       | uint16    | ID number of the compromise associated with this event.  |
| Security Context | uint8(16) | ID number for the security context (virtual firewall) that the traffic passed through. Note that the system only populates this field for ASA FirePOWER devices in multi-context mode.                     |

## File Event SHA Hash for 5.3+

The eStreamer service uses the File Event SHA Hash data block to contain metadata of the mapping of the SHA hash of a file to its filename. The block type is 40 in the series 2 list of data blocks. It can be requested if file log events have been requested in the extended requests—event code 111—and either bit 20 is set or metadata is requested with an event version of 5 and an event code of 21.

The following diagram shows the structure of a file event hash data block:

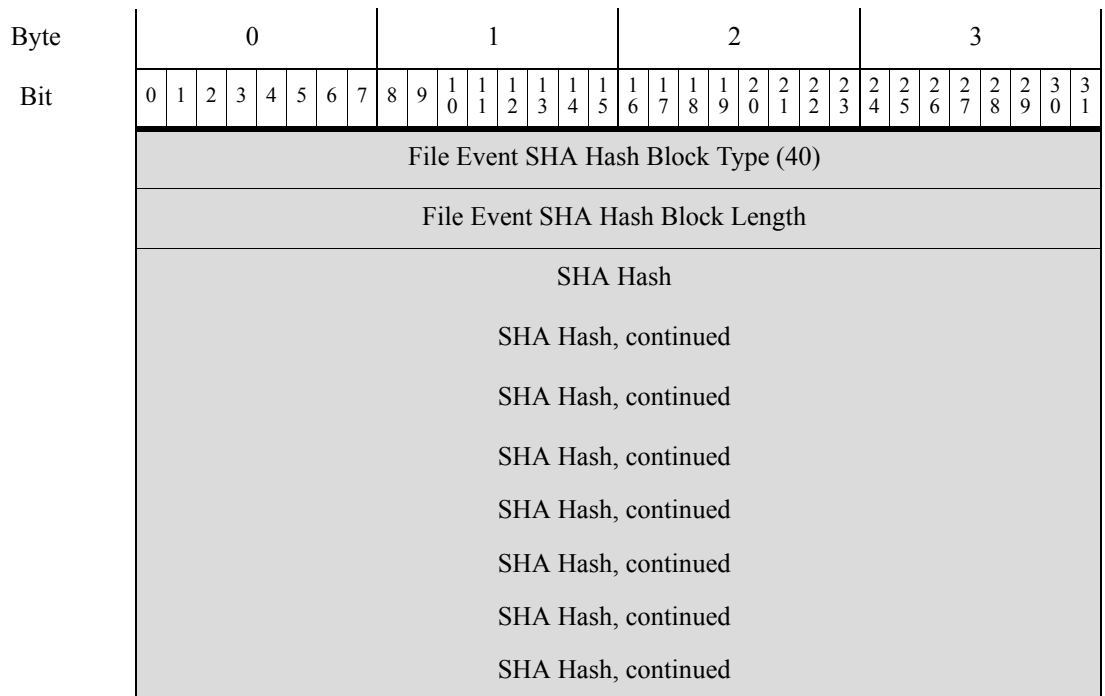

| Byte        | 0                     |   |   |   |   |   |   |   | 1 |   |    |    |    |    |    |              | 2  |    |    |    |    |    |    |    | 3  |    |    |    |    |    |    |    |
|-------------|-----------------------|---|---|---|---|---|---|---|---|---|----|----|----|----|----|--------------|----|----|----|----|----|----|----|----|----|----|----|----|----|----|----|----|
| Bit         | 0                     | 1 | 2 | 3 | 4 | 5 | 6 | 7 | 8 | 9 | 10 | 11 | 12 | 13 | 14 | 15           | 16 | 17 | 18 | 19 | 20 | 21 | 22 | 23 | 24 | 25 | 26 | 27 | 28 | 29 | 30 | 31 |
| File Name   | String Block Type (0) |   |   |   |   |   |   |   |   |   |    |    |    |    |    |              |    |    |    |    |    |    |    |    |    |    |    |    |    |    |    |    |
|             | String Block Length   |   |   |   |   |   |   |   |   |   |    |    |    |    |    |              |    |    |    |    |    |    |    |    |    |    |    |    |    |    |    |    |
|             | File Name...          |   |   |   |   |   |   |   |   |   |    |    |    |    |    |              |    |    |    |    |    |    |    |    |    |    |    |    |    |    |    |    |
| Disposition |                       |   |   |   |   |   |   |   |   |   |    |    |    |    |    | User Defined |    |    |    |    |    |    |    |    |    |    |    |    |    |    |    |    |

The following table describes the fields in the file event SHA hash data block.

**Table 3-39** File Event SHA Hash Data Block Fields

| Field                            | Data Type | Description  |
|----------------------------------|-----------|--|
| File Event SHA Hash Block Type   | uint32    | Initiates a File Event SHA Hash block. This value is always 26.  |
| File Event SHA Hash Block Length | uint32    | Total number of bytes in the File Event SHA Hash block, including eight bytes for the File Event SHA Hash block type and length fields, plus the number of bytes of data that follows.   |
| SHA Hash                         | uint8[32] | The SHA-256 hash of the file in binary format.   |
| String Block Type                | uint32    | Initiates a String data block containing the descriptive name associated with the file. This value is always 0.  |
| String Block Length              | uint32    | The number of bytes included in the name String data block, including eight bytes for the block type and header fields plus the number of bytes in the Name field.   |
| File Name or Disposition         | string    | The descriptive name or disposition of the file. If the file is clean, this value is <code>Clean</code> . If the file's disposition is unknown, the value is <code>Neutral</code> . If the file contains malware, the file name is given.  |
| Disposition                      | uint8     | The malware status of the file. Possible values include: <ul style="list-style-type: none"> <li>1 - CLEAN The file is clean and does not contain malware.</li> <li>2 - UNKNOWN It is unknown whether the file contains malware.</li> <li>3 - MALWARE The file contains malware.</li> <li>4 - UNAVAILABLE The software was unable to send a request to the Cisco cloud for a disposition, or the Cisco cloud services did not respond to the request.</li> <li>5 - CUSTOM SIGNATURE The file matches a user-defined hash, and is treated in a fashion designated by the user</li> </ul> |
| User Defined                     | uint8     | Indicated how the file name was provided: <ul style="list-style-type: none"> <li>0 - defined by AMP</li> <li>1 - user defined</li> </ul>   |

## Rule Documentation Data Block for 5.2+

The eStreamer service uses the Rule Documentation data block to contain information about rules used to generate alerts. The block type is 27 in the series 2 set of data blocks. It can be requested with a host request message of type 10. See [Host Request Message Format, page 2-24](#) for more information.

The following diagram shows the structure of a rule documentation data block:

| Byte             | 0                                  |   |   |   |   |   |   |   | 1 |   |    |    |    |    |    |    | 2  |    |    |    |    |    |    |    | 3  |    |    |    |    |    |    |    |
|------------------|------------------------------------|---|---|---|---|---|---|---|---|---|----|----|----|----|----|----|----|----|----|----|----|----|----|----|----|----|----|----|----|----|----|----|
| Bit              | 0                                  | 1 | 2 | 3 | 4 | 5 | 6 | 7 | 8 | 9 | 10 | 11 | 12 | 13 | 14 | 15 | 16 | 17 | 18 | 19 | 20 | 21 | 22 | 23 | 24 | 25 | 26 | 27 | 28 | 29 | 30 | 31 |
|                  | Rule Documentation Block Type (27) |   |   |   |   |   |   |   |   |   |    |    |    |    |    |    |    |    |    |    |    |    |    |    |    |    |    |    |    |    |    |    |
|                  | Rule Documentation Block Length    |   |   |   |   |   |   |   |   |   |    |    |    |    |    |    |    |    |    |    |    |    |    |    |    |    |    |    |    |    |    |    |
|                  | Signature ID                       |   |   |   |   |   |   |   |   |   |    |    |    |    |    |    |    |    |    |    |    |    |    |    |    |    |    |    |    |    |    |    |
|                  | Generator ID                       |   |   |   |   |   |   |   |   |   |    |    |    |    |    |    |    |    |    |    |    |    |    |    |    |    |    |    |    |    |    |    |
|                  | Revision                           |   |   |   |   |   |   |   |   |   |    |    |    |    |    |    |    |    |    |    |    |    |    |    |    |    |    |    |    |    |    |    |
| Summary          | String Block Type (0)              |   |   |   |   |   |   |   |   |   |    |    |    |    |    |    |    |    |    |    |    |    |    |    |    |    |    |    |    |    |    |    |
|                  | String Block Length                |   |   |   |   |   |   |   |   |   |    |    |    |    |    |    |    |    |    |    |    |    |    |    |    |    |    |    |    |    |    |    |
|                  | Summary...                         |   |   |   |   |   |   |   |   |   |    |    |    |    |    |    |    |    |    |    |    |    |    |    |    |    |    |    |    |    |    |    |
| Impact           | String Block Type (0)              |   |   |   |   |   |   |   |   |   |    |    |    |    |    |    |    |    |    |    |    |    |    |    |    |    |    |    |    |    |    |    |
|                  | String Block Length                |   |   |   |   |   |   |   |   |   |    |    |    |    |    |    |    |    |    |    |    |    |    |    |    |    |    |    |    |    |    |    |
|                  | Impact...                          |   |   |   |   |   |   |   |   |   |    |    |    |    |    |    |    |    |    |    |    |    |    |    |    |    |    |    |    |    |    |    |
| Detailed Info    | String Block Type (0)              |   |   |   |   |   |   |   |   |   |    |    |    |    |    |    |    |    |    |    |    |    |    |    |    |    |    |    |    |    |    |    |
|                  | String Block Length                |   |   |   |   |   |   |   |   |   |    |    |    |    |    |    |    |    |    |    |    |    |    |    |    |    |    |    |    |    |    |    |
|                  | Detailed Information               |   |   |   |   |   |   |   |   |   |    |    |    |    |    |    |    |    |    |    |    |    |    |    |    |    |    |    |    |    |    |    |
| Affected Systems | String Block Type (0)              |   |   |   |   |   |   |   |   |   |    |    |    |    |    |    |    |    |    |    |    |    |    |    |    |    |    |    |    |    |    |    |
|                  | String Block Length                |   |   |   |   |   |   |   |   |   |    |    |    |    |    |    |    |    |    |    |    |    |    |    |    |    |    |    |    |    |    |    |
|                  | Affected Systems...                |   |   |   |   |   |   |   |   |   |    |    |    |    |    |    |    |    |    |    |    |    |    |    |    |    |    |    |    |    |    |    |
| Attack Scenarios | String Block Type (0)              |   |   |   |   |   |   |   |   |   |    |    |    |    |    |    |    |    |    |    |    |    |    |    |    |    |    |    |    |    |    |    |
|                  | String Block Length                |   |   |   |   |   |   |   |   |   |    |    |    |    |    |    |    |    |    |    |    |    |    |    |    |    |    |    |    |    |    |    |
|                  | Attack Scenarios...                |   |   |   |   |   |   |   |   |   |    |    |    |    |    |    |    |    |    |    |    |    |    |    |    |    |    |    |    |    |    |    |

| Byte                  | 0                        |   |   |   |   |   |   |   | 1 |   |    |    |    |    |    |    | 2  |    |    |    |    |    |    |    | 3  |    |    |    |    |    |    |    |
|-----------------------|--------------------------|---|---|---|---|---|---|---|---|---|----|----|----|----|----|----|----|----|----|----|----|----|----|----|----|----|----|----|----|----|----|----|
|                       | 0                        | 1 | 2 | 3 | 4 | 5 | 6 | 7 | 8 | 9 | 10 | 11 | 12 | 13 | 14 | 15 | 16 | 17 | 18 | 19 | 20 | 21 | 22 | 23 | 24 | 25 | 26 | 27 | 28 | 29 | 30 | 31 |
| Ease of Attack        | String Block Type (0)    |   |   |   |   |   |   |   |   |   |    |    |    |    |    |    |    |    |    |    |    |    |    |    |    |    |    |    |    |    |    |    |
|                       | String Block Length      |   |   |   |   |   |   |   |   |   |    |    |    |    |    |    |    |    |    |    |    |    |    |    |    |    |    |    |    |    |    |    |
|                       | Ease of Attack...        |   |   |   |   |   |   |   |   |   |    |    |    |    |    |    |    |    |    |    |    |    |    |    |    |    |    |    |    |    |    |    |
| False Positives       | String Block Type (0)    |   |   |   |   |   |   |   |   |   |    |    |    |    |    |    |    |    |    |    |    |    |    |    |    |    |    |    |    |    |    |    |
|                       | String Block Length      |   |   |   |   |   |   |   |   |   |    |    |    |    |    |    |    |    |    |    |    |    |    |    |    |    |    |    |    |    |    |    |
|                       | False Positives...       |   |   |   |   |   |   |   |   |   |    |    |    |    |    |    |    |    |    |    |    |    |    |    |    |    |    |    |    |    |    |    |
| False Negatives       | String Block Type (0)    |   |   |   |   |   |   |   |   |   |    |    |    |    |    |    |    |    |    |    |    |    |    |    |    |    |    |    |    |    |    |    |
|                       | String Block Length      |   |   |   |   |   |   |   |   |   |    |    |    |    |    |    |    |    |    |    |    |    |    |    |    |    |    |    |    |    |    |    |
|                       | False Negatives...       |   |   |   |   |   |   |   |   |   |    |    |    |    |    |    |    |    |    |    |    |    |    |    |    |    |    |    |    |    |    |    |
| Corrective Action     | String Block Type (0)    |   |   |   |   |   |   |   |   |   |    |    |    |    |    |    |    |    |    |    |    |    |    |    |    |    |    |    |    |    |    |    |
|                       | String Block Length      |   |   |   |   |   |   |   |   |   |    |    |    |    |    |    |    |    |    |    |    |    |    |    |    |    |    |    |    |    |    |    |
|                       | Corrective Action...     |   |   |   |   |   |   |   |   |   |    |    |    |    |    |    |    |    |    |    |    |    |    |    |    |    |    |    |    |    |    |    |
| Contributors          | String Block Type (0)    |   |   |   |   |   |   |   |   |   |    |    |    |    |    |    |    |    |    |    |    |    |    |    |    |    |    |    |    |    |    |    |
|                       | String Block Length      |   |   |   |   |   |   |   |   |   |    |    |    |    |    |    |    |    |    |    |    |    |    |    |    |    |    |    |    |    |    |    |
|                       | Contributors...          |   |   |   |   |   |   |   |   |   |    |    |    |    |    |    |    |    |    |    |    |    |    |    |    |    |    |    |    |    |    |    |
| Additional References | String Block Type (0)    |   |   |   |   |   |   |   |   |   |    |    |    |    |    |    |    |    |    |    |    |    |    |    |    |    |    |    |    |    |    |    |
|                       | String Block Length      |   |   |   |   |   |   |   |   |   |    |    |    |    |    |    |    |    |    |    |    |    |    |    |    |    |    |    |    |    |    |    |
|                       | Additional References... |   |   |   |   |   |   |   |   |   |    |    |    |    |    |    |    |    |    |    |    |    |    |    |    |    |    |    |    |    |    |    |

The following table describes the fields in the rule documentation data block.

**Table 3-40 Rule Documentation Data Block Fields**

| Field                                | Data Type | Description  |
|--------------------------------------|-----------|--|
| Rule Documentation Data Block Type   | uint32    | Initiates a Rule Documentation data block. This value is always 27.  |
| Rule Documentation Data Block Length | uint32    | Total number of bytes in the Rule Documentation data block, including eight bytes for the Rule Documentation data block type and length fields, plus the number of bytes of data that follows. |
| Rule ID (Signature ID)               | uint32    | Rule identification number that corresponds with the event.  |



Table 3-40 Rule Documentation Data Block Fields (continued)

| Field                | Data Type | Description  |
|----------------------|-----------|--|
| Generator ID         | uint32    | Identification number of the FireSIGHT System preprocessor that generated the event.   |
| Rule Revision        | uint32    | Rule revision number.  |
| String Block Type    | uint32    | Initiates a String data block containing the summary associated with the rule. This value is always 0.   |
| String Block Length  | uint32    | The number of bytes included in the name String data block, including eight bytes for the block type and header fields plus the number of bytes in the Summary field.              |
| Summary              | string    | Explanation of the threat or vulnerability.  |
| String Block Type    | uint32    | Initiates a String data block containing the impact associated with the rule. This value is always 0.  |
| String Block Length  | uint32    | The number of bytes included in the name String data block, including eight bytes for the block type and header fields plus the number of bytes in the Impact field.               |
| Impact               | string    | How a compromise that uses this vulnerability may impact various systems.  |
| String Block Type    | uint32    | Initiates a String data block containing the detailed information associated with the rule. This value is always 0.  |
| String Block Length  | uint32    | The number of bytes included in the name String data block, including eight bytes for the block type and header fields plus the number of bytes in the Detailed Information field. |
| Detailed Information | string    | Information regarding the underlying vulnerability, what the rule actually looks for, and what systems are affected.   |
| String Block Type    | uint32    | Initiates a String data block containing the list of affected systems associated with the rule. This value is always 0.  |
| String Block Length  | uint32    | The number of bytes included in the name String data block, including eight bytes for the block type and header fields plus the number of bytes in the Affected Systems field.     |
| Affected Systems     | string    | Systems affected by the vulnerability.   |
| String Block Type    | uint32    | Initiates a String data block containing the possible attack scenarios associated with the rule. This value is always 0.   |
| String Block Length  | uint32    | The number of bytes included in the name String data block, including eight bytes for the block type and header fields plus the number of bytes in the Attack Scenarios field.     |
| Attack Scenarios     | string    | Examples of possible attacks.  |
| String Block Type    | uint32    | Initiates a String data block containing the ease of attack associated with the rule. This value is always 0.  |
| String Block Length  | uint32    | The number of bytes included in the name String data block, including eight bytes for the block type and header fields plus the number of bytes in the Ease of Attack field.       |
| Ease of Attack       | string    | Whether the attack is considered simple, medium, hard, or difficult, and whether or not it can be performed using a script.  |

Table 3-40 Rule Documentation Data Block Fields (continued)

| Field                 | Data Type | Description   |
|-----------------------|-----------|---|
| String Block Type     | uint32    | Initiates a String data block containing the possible false positives associated with the rule. This value is always 0.   |
| String Block Length   | uint32    | The number of bytes included in the name String data block, including eight bytes for the block type and header fields plus the number of bytes in the False Positives field.       |
| False Positives       | string    | Examples that may result in a false positive. The default value is None Known.  |
| String Block Type     | uint32    | Initiates a String data block containing the possible false negatives associated with the rule. This value is always 0.   |
| String Block Length   | uint32    | The number of bytes included in the name String data block, including eight bytes for the block type and header fields plus the number of bytes in the False Negatives field.       |
| False Negatives       | string    | Examples that may result in a false negative. The default value is None Known.  |
| String Block Type     | uint32    | Initiates a String data block containing the corrective action associated with the rule. This value is always 0.  |
| String Block Length   | uint32    | The number of bytes included in the name String data block, including eight bytes for the block type and header fields plus the number of bytes in the Corrective Action field.     |
| Corrective Action     | string    | Information regarding patches, upgrades, or other means to remove or mitigate the vulnerability.  |
| String Block Type     | uint32    | Initiates a String data block containing the contributors for the rule. This value is always 0.   |
| String Block Length   | uint32    | The number of bytes included in the name String data block, including eight bytes for the block type and header fields plus the number of bytes in the Contributors field.          |
| Contributors          | string    | Contact information for the author of the rule and other relevant documentation.  |
| String Block Type     | uint32    | Initiates a String data block containing the additional references associated with the rule. This value is always 0.  |
| String Block Length   | uint32    | The number of bytes included in the name String data block, including eight bytes for the block type and header fields plus the number of bytes in the Additional References field. |
| Additional References | string    | Additional information and references.  |

## Geolocation Data Block for 5.2+

This is a data block that contains the mapping of a country code to a country name. The record type is 520, and a block type of 28 in series 2. It is exposed as metadata for any event that has geolocation information. If metadata is requested and there is a value for the country code(s) in the event, then this block is returned along with other metadata.

The following diagram shows the structure of a geolocation data block:

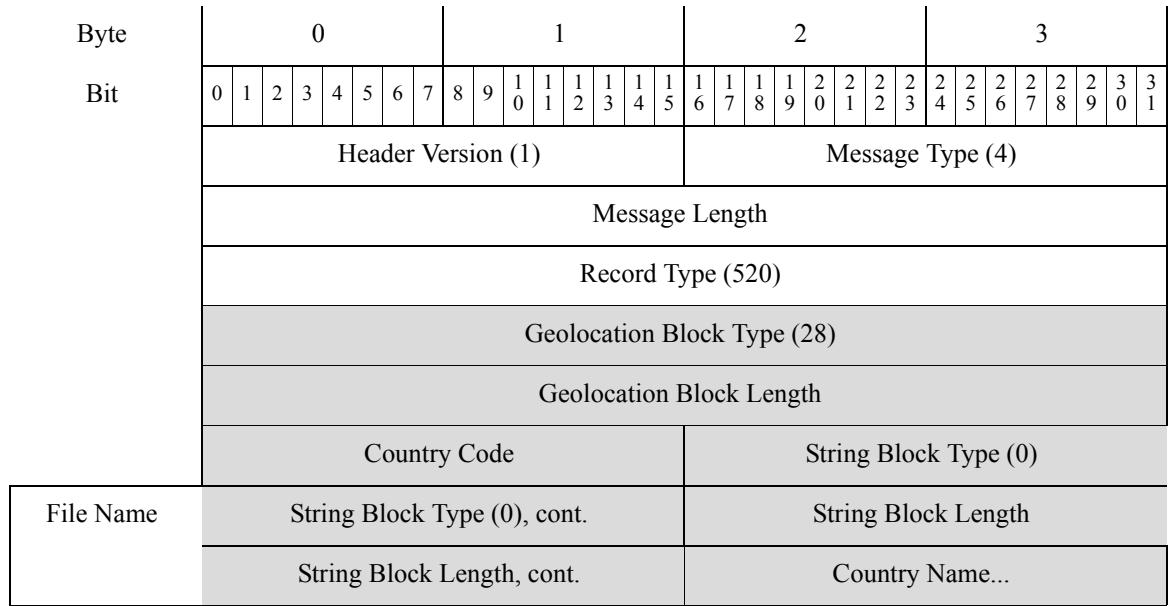

The following table describes the fields in the Geolocation data block.

**Table 3-41 Geolocation Data Block Fields**

| Field                         | Data Type | Description  |
|-------------------------------|-----------|--|
| Geolocation Data Block Type   | uint32    | Initiates a Geolocation data block. This value is always 28.   |
| Geolocation Data Block Length | uint32    | Total number of bytes in the Geolocation data block, including eight bytes for the Geolocation data block type and length fields, plus the number of bytes of data that follows. |
| Country Code                  | uint16    | The country code.  |
| String Block Type             | uint32    | Initiates a String data block containing the country name associated with the country code. This value is always 0.  |
| String Block Length           | uint32    | The number of bytes included in the name String data block, including eight bytes for the block type and header fields plus the number of bytes in the Country Name field.       |
| Country Name                  | string    | The name of the country associated with the country code.  |





# Understanding Discovery & Connection Data Structures

---

This chapter provides details about the data structures used in eStreamer messages for discovery and connection events, as well as the metadata for those events. Discovery and connection event messages use the same general message format and series of data blocks; the differences are in the contents of data blocks themselves.

Discovery events include two sub-categories of events:

- Host discovery events, which identify new and changed hosts on your managed network, including the applications running on the hosts detected from the contents of the packets, and the host vulnerabilities.
- User events, which report the detection of new users and user activity, such as logins.

Connection events report information about the session traffic between your monitored hosts and all other hosts. Connection information includes the first and last packet of the transaction, source and destination IP address, source and destination port, and the number of packets and bytes sent and received. If applicable, connection events also report the client application and URL involved in the session.

For information about requesting discovery or connection events from the eStreamer server, see [Request Flags, page 2-11](#).

For information about the general structure of eStreamer event data messages, see [Understanding the Organization of Event Data Messages, page 2-17](#).

See the following sections in this chapter for more information about discovery and connection event data structures:

- [Discovery and Connection Event Data Messages, page 4-2](#) provides a high-level view of the structure that eStreamer uses for host discovery, user, and connection messages.
- [Discovery and Connection Event Record Types, page 4-2](#) describes the record types for discovery and connection events.
- [Metadata for Discovery Events, page 4-6](#) describes the metadata records that you can request for context information to convert numeric and coded data to text; for example, convert the user ID in an event to a user name.
- [Discovery Event Header 5.2+, page 4-32](#) describes the structure of the standard event header used in all discovery and connection messages, and the values that can occur in the event type and event subtype fields. The event type and subtype fields further define the structure of the data record carried in the message.

- [Host Discovery Structures by Event Type, page 4-37](#) describes the structure of the data record that eStreamer uses for the various host discovery event types.
- [User Data Structures by Event Type, page 4-54](#) describes the structure of the data record that eStreamer uses for the various user event types.
- [Understanding Discovery \(Series 1\) Blocks, page 4-55](#) describes the series of data block structures that are used to convey complex records in discovery and connection event messages. Series 1 data blocks also appear in correlation events.
- [User Vulnerability Data Block 5.0+, page 4-139](#) describes other series 1 block structures that are used to convey complex user event records.



Tip

See “Data Structure Examples” section on page A-1 for examples that illustrate sample discovery events.

## Discovery and Connection Event Data Messages

eStreamer packages the data for discovery and connection events in the same message structure, which contains:

- a record header that defines the record type
- a discovery event header that identifies and characterizes the event, and specifically identifies the event type and subtype. For information, see [Discovery Event Header 5.2+, page 4-32](#).
- a data record consisting of a block header and a data block. Discovery and connection event data messages use series 1 data blocks. For information, see [Host Discovery and Connection Data Blocks, page 4-56](#) or [User Vulnerability Data Block 5.0+, page 4-139](#).

## Discovery and Connection Event Record Types

The following table lists the event record types for host discovery and connection events, and provides links to the event message structure for each record type. The list includes metadata record types as well. Some records contain a single data block which stores a specific piece of data. These data blocks are broken up into series 1 blocks that contain most types of data, and series 2 blocks that specifically contain discovery data. The table also indicates the status of each version (current or legacy). A current record is the latest version. A legacy record has been superseded by a later version but can still be requested from eStreamer.

**Table 4-1** *Discovery and Connection Event Record Types*

| Record Type | Contains Block Type | Series | Description            | Record Status | Data Format Described in...                                     |
|-------------|---------------------|--------|------------------------|---------------|---|
| 10          | 139                 | 1      | New Host Detected      | Current       | <a href="#">New Host and Host Last Seen Messages, page 4-38</a> |
| 11          | 103                 | 1      | New TCP Server         | Current       | <a href="#">Server Messages, page 4-38</a>                      |
| 12          | 103                 | 1      | New UDP Server         | Current       | <a href="#">Server Messages, page 4-38</a>                      |
| 13          | 4                   | 1      | New Network Protocol   | Current       | <a href="#">New Network Protocol Message, page 4-39</a>         |
| 14          | 4                   | 1      | New Transport Protocol | Current       | <a href="#">New Transport Protocol Message, page 4-39</a>       |
| 15          | 122                 | 1      | New Client Application | Current       | <a href="#">Client Application Messages, page 4-40</a>          |

Table 4-1 Discovery and Connection Event Record Types (continued)

| Record Type | Contains Block Type | Series | Description                      | Record Status | Data Format Described in...  |
|-------------|---------------------|--------|----------------------------------|---------------|--|
| 16          | 103                 | 1      | TCP Server Information Update    | Current       | <a href="#">Server Messages, page 4-38</a>                                     |
| 17          | 103                 | 1      | UDP Server Information Update    | Current       | <a href="#">Server Messages, page 4-38</a>                                     |
| 18          | 53                  | 1      | OS Information Update            | Current       | <a href="#">Operating System Update Messages, page 4-41</a>                    |
| 19          | N/A                 | N/A    | Host Timeout                     | Current       | <a href="#">IP Address Reused and Host Timeout/Deleted Messages, page 4-42</a> |
| 20          | N/A                 | N/A    | Host IP Address Reused           | Current       | <a href="#">IP Address Reused and Host Timeout/Deleted Messages, page 4-42</a> |
| 21          | N/A                 | N/A    | Host Deleted: Host Limit Reached | Current       | <a href="#">IP Address Reused and Host Timeout/Deleted Messages, page 4-42</a> |
| 22          | N/A                 | N/A    | Hops Change                      | Current       | <a href="#">Hops Change Message, page 4-43</a>                                 |
| 23          | N/A                 | N/A    | TCP Port Closed                  | Current       | <a href="#">TCP and UDP Port Closed/Timeout Messages, page 4-43</a>            |
| 24          | N/A                 | N/A    | UDP Port Closed                  | Current       | <a href="#">TCP and UDP Port Closed/Timeout Messages, page 4-43</a>            |
| 25          | N/A                 | N/A    | TCP Port Timeout                 | Current       | <a href="#">TCP and UDP Port Closed/Timeout Messages, page 4-43</a>            |
| 26          | N/A                 | N/A    | UDP Port Timeout                 | Current       | <a href="#">TCP and UDP Port Closed/Timeout Messages, page 4-43</a>            |
| 27          | N/A                 | N/A    | MAC Information Change           | Current       | <a href="#">MAC Address Messages, page 4-43</a>                                |
| 28          | N/A                 | N/A    | Additional MAC Detected for Host | Current       | <a href="#">MAC Address Messages, page 4-43</a>                                |
| 29          | N/A                 | N/A    | Host IP Address Changed          | Current       | <a href="#">IP Address Change Message, page 4-40</a>                           |
| 30          | 139                 | 1      | Host Last Seen                   | Current       | <a href="#">New Host and Host Last Seen Messages, page 4-38</a>                |
| 31          | N/A                 | N/A    | Host Identified as Router/Bridge | Current       | <a href="#">Host Identified as a Bridge/Router Message, page 4-44</a>          |
| 32          | 8                   | 1      | Vulnerability Change             | Current       | <a href="#">Vulnerability Change Message, page 4-42</a>                        |
| 33          | 144                 | 1      | Connection Statistics            | Legacy        | <a href="#">Connection Statistics Data Block 5.2.x, page B-89</a>              |
| 33          | 152                 | 1      | Connection Statistics            | Legacy        | <a href="#">Connection Statistics Data Block 5.3, page B-102</a>               |
| 33          | 154                 | 1      | Connection Statistics            | Current       | <a href="#">Connection Statistics Data Block 5.3.1+, page 4-111</a>            |
| 34          | 14                  | 1      | VLAN Tag Information Update      | Current       | <a href="#">VLAN Tag Information Update Messages, page 4-44</a>                |
| 35          | 122                 | 1      | Client Application Timeout       | Current       | <a href="#">Client Application Messages, page 4-40</a>                         |
| 42          | 35                  | 1      | NetBIOS Name Change              | Current       | <a href="#">Change NetBIOS Name Message, page 4-45</a>                         |

Table 4-1 Discovery and Connection Event Record Types (continued)

| Record Type | Contains Block Type | Series | Description                      | Record Status | Data Format Described in...   |
|-------------|---------------------|--------|----------------------------------|---------------|---|
| 44          | N/A                 | N/A    | Host Dropped: Host Limit Reached | Current       | <a href="#">IP Address Reused and Host Timeout/Deleted Messages, page 4-42</a>  |
| 45          | 37                  | 1      | Update Banner                    | Current       | <a href="#">Update Banner Message, page 4-45</a>                                |
| 46          | 55                  | 1      | Add Host Attribute               | Current       | <a href="#">Attribute Messages, page 4-50</a>                                   |
| 47          | 55                  | 1      | Update Host Attribute            | Current       | <a href="#">Attribute Messages, page 4-50</a>                                   |
| 48          | 55                  | 1      | Delete Host Attribute            | Current       | <a href="#">Attribute Messages, page 4-50</a>                                   |
| 51          | 103                 | 1      | TCP Server Confidence Update     | Legacy        | <a href="#">Server Messages, page 4-38</a>                                      |
| 52          | 103                 | 1      | UDP Server Confidence Update     | Legacy        | <a href="#">Server Messages, page 4-38</a>                                      |
| 53          | 53                  | 1      | OS Confidence Update             | Legacy        | <a href="#">Operating System Update Messages, page 4-41</a>                     |
| 54          | N/A                 | N/A    | Fingerprint Metadata             | Current       | <a href="#">Fingerprint Record, page 4-7</a>                                    |
| 55          | N/A                 | N/A    | Client Application Metadata      | Current       | <a href="#">Client Application Record, page 4-8</a>                             |
| 57          | N/A                 | N/A    | Vulnerability Metadata           | Current       | <a href="#">Vulnerability Record, page 4-9</a>                                  |
| 58          | N/A                 | N/A    | Criticality Metadata             | Current       | <a href="#">Criticality Record, page 4-11</a>                                   |
| 59          | N/A                 | N/A    | Network Protocol Metadata        | Current       | <a href="#">Network Protocol Record, page 4-12</a>                              |
| 60          | N/A                 | N/A    | Attribute Metadata               | Current       | <a href="#">Attribute Record, page 4-13</a>                                     |
| 61          | N/A                 | N/A    | Scan Type Metadata               | Current       | <a href="#">Scan Type Record, page 4-14</a>                                     |
| 63          | N/A                 | N/A    | Server Metadata                  | Current       | <a href="#">Server Record, page 4-14</a>  |
| 71          | 144                 | 1      | Connection Statistics            | Legacy        | <a href="#">Connection Statistics Data Block 5.2.x, page B-89</a>               |
| 71          | 152                 | 1      | Connection Statistics            | Legacy        | <a href="#">Connection Statistics Data Block 5.3, page B-102</a>                |
| 71          | 154                 | 1      | Connection Statistics            | Current       | <a href="#">Connection Statistics Data Block 5.3.1+, page 4-111</a>             |
| 73          | 136                 | 1      | Connection Chunks                | Current       | <a href="#">Connection Chunk Message, page 4-47</a>                             |
| 74          | N/A                 | N/A    | User Set OS                      | Current       | <a href="#">User Server and Operating System Messages, page 4-51</a>            |
| 75          | N/A                 | N/A    | User Set Server                  | Current       | <a href="#">User Server and Operating System Messages, page 4-51</a>            |
| 76          | 83                  | 1      | User Delete Protocol             | Current       | <a href="#">User Protocol Messages, page 4-51</a>                               |
| 77          | 60                  | 1      | User Delete Client Application   | Current       | <a href="#">User Client Application Messages, page 4-52</a>                     |
| 78          | 78                  | 1      | User Delete Address              | Current       | <a href="#">User Add and Delete Host Messages, page 4-48</a>                    |
| 79          | 77                  | 1      | User Delete Server               | Current       | <a href="#">User Delete Server Message, page 4-49</a>                           |
| 80          | 80                  | 1      | User Set Valid Vulnerabilities   | Current       | <a href="#">User Set Vulnerabilities Messages for Version 4.6.1+, page 4-47</a> |



Table 4-1 Discovery and Connection Event Record Types (continued)

| Record Type | Contains Block Type | Series | Description                              | Record Status | Data Format Described in...   |
|-------------|---------------------|--------|--|---------------|---|
| 81          | 80                  | 1      | User Set Invalid Vulnerabilities         | Current       | <a href="#">User Set Vulnerabilities Messages for Version 4.6.1+, page 4-47</a>   |
| 82          | 81                  | 1      | User Set Host Criticality                | Current       | <a href="#">User Set Host Criticality Messages, page 4-49</a>                     |
| 83          | 55                  | 1      | User Set Attribute Value                 | Current       | <a href="#">Attribute Value Messages, page 4-50</a>                               |
| 84          | 82                  | 1      | User Delete Attribute Value              | Current       | <a href="#">Attribute Value Messages, page 4-50</a>                               |
| 85          | 78                  | 1      | User Add Host                            | Current       | <a href="#">User Add and Delete Host Messages, page 4-48</a>                      |
| 86          | N/A                 | N/A    | User Add Server                          | Current       | <a href="#">User Server and Operating System Messages, page 4-51</a>              |
| 87          | 60                  | 1      | User Add Client Application              | Current       | <a href="#">User Client Application Messages, page 4-52</a>                       |
| 88          | 83                  | 1      | User Add Protocol                        | Current       | <a href="#">User Protocol Messages, page 4-51</a>                                 |
| 89          | 142                 | 1      | User Add Scan Result                     | Current       | <a href="#">Add Scan Result Messages, page 4-52</a>                               |
| 90          | N/A                 | N/A    | Source Type Record                       | Current       | <a href="#">Source Type Record, page 4-15</a>                                     |
| 91          | N/A                 | N/A    | Source Application Record                | Current       | <a href="#">Source Application Record, page 4-16</a>                              |
| 92          | 120                 | 1      | User Dropped Change Event                | Current       | <a href="#">User Modification Messages, page 4-54</a>                             |
| 93          | 120                 | 1      | User Removed Change Event                | Current       | <a href="#">User Modification Messages, page 4-54</a>                             |
| 94          | 120                 | 1      | New User Identification Event            | Current       | <a href="#">User Modification Messages, page 4-54</a>                             |
| 95          | 121                 | 1      | User Login Change Event                  | Current       | <a href="#">User Information Update Message Block, page 4-55</a>                  |
| 96          | N/A                 | N/A    | Source Detector Record                   | Current       | <a href="#">Source Detector Record, page 4-17</a>                                 |
| 98          | N/A                 | N/A    | User Record                              | Current       | <a href="#">User Record, page 4-19</a>  |
| 101         | N/A                 | N/A    | New OS Event                             | Current       | <a href="#">New Operating System Messages, page 4-53</a>                          |
| 102         | 94                  | 1      | Identity Conflict Event                  | Current       | <a href="#">Identity Conflict and Identity Timeout System Messages, page 4-53</a> |
| 103         | 94                  | 1      | Identity Timeout Event                   | Current       | <a href="#">Identity Conflict and Identity Timeout System Messages, page 4-53</a> |
| 106         | N/A                 | N/A    | Third Party Scanner Vulnerability Record | Current       | <a href="#">Third Party Scanner Vulnerability Record, page 4-18</a>               |
| 107         | 122                 | 1      | Client Application Update                | Current       | <a href="#">Client Application Messages, page 4-40</a>                            |
| 109         | N/A                 | N/A    | Web Application Record                   | Current       | <a href="#">Web Application Record, page 4-20</a>                                 |
| 115         | N/A                 | N/A    | Security Zone Name Record                | Current       | <a href="#">Security Zone Name Record, page 3-25</a>                              |

Table 4-1 Discovery and Connection Event Record Types (continued)

| Record Type | Contains Block Type | Series | Description                                       | Record Status | Data Format Described in...  |
|-------------|---------------------|--------|---|---------------|--|
| 116         | 14                  | 2      | Interface Name Record                             | Current       | <a href="#">Interface Name Record, page 3-26</a>                           |
| 117         | 14                  | 2      | Access Control Policy Name Metadata               | Current       | <a href="#">Access Control Policy Name Record, page 3-27</a>               |
| 118         | 14                  | 2      | Intrusion Policy Name Record                      | Current       | <a href="#">Intrusion Policy Name Record, page 4-20</a>                    |
| 119         | 14                  | 2      | Access Control Rule ID Record                     | Current       | <a href="#">Access Control Rule ID Record Metadata, page 3-28</a>          |
| 120         | N/A                 | N/A    | Access Control Rule Action Record                 | Current       | <a href="#">Access Control Rule Action Record Metadata, page 4-22</a>      |
| 121         | N/A                 | N/A    | URL Category Record                               | Current       | <a href="#">URL Category Record Metadata, page 4-22</a>                    |
| 122         | N/A                 | N/A    | URL Reputation Metadata                           | Current       | <a href="#">URL Reputation Record Metadata, page 4-23</a>                  |
| 124         | 21                  | 2      | Access Control Rule Reason Metadata               | Current       | <a href="#">Access Control Rule Reason Metadata, page 4-24</a>             |
| 160         | 7                   | 1      | Host IOC Set Messages                             | Current       | <a href="#">Host IOC Set Messages, page 4-53</a>                           |
| 161         | 39                  | 2      | IOC Name Data Block                               | Current       | <a href="#">IOC Name Data Block for 5.3+, page 4-27</a>                    |
| 280         | 22                  | 2      | Security Intelligence Category Metadata           | Current       | <a href="#">IOC State Data Block for 5.3+, page 4-25</a>                   |
| 281         | N/A                 | N/A    | Security Intelligence Source/Destination Metadata | Current       | <a href="#">Security Intelligence Source/Destination Record, page 4-31</a> |

## Metadata for Discovery Events

You request metadata by metadata version number. For the metadata version that corresponds to your version of the FireSIGHT System, see [Understanding Metadata, page 2-38](#). For important information on how eStreamer streams metadata records, see [Metadata Transmission, page 2-38](#).

For information on the structures of the various metadata records types for host discovery and user event records, see:

- [Fingerprint Record, page 4-7](#)
- [Client Application Record, page 4-8](#)
- [Vulnerability Record, page 4-9](#)
- [Criticality Record, page 4-11](#)
- [Network Protocol Record, page 4-12](#)
- [Attribute Record, page 4-13](#)
- [Scan Type Record, page 4-14](#)
- [Server Record, page 4-14](#)
- [Source Type Record, page 4-15](#)

- [Source Application Record](#), page 4-16
- [Source Detector Record](#), page 4-17
- [Third Party Scanner Vulnerability Record](#), page 4-18
- [User Record](#), page 4-19
- [Web Application Record](#), page 4-20
- [Intrusion Policy Name Record](#), page 4-20
- [Access Control Rule Action Record Metadata](#), page 4-22
- [URL Category Record Metadata](#), page 4-22
- [URL Reputation Record Metadata](#), page 4-23
- [Access Control Rule Reason Metadata](#), page 4-24
- [IOC State Data Block for 5.3+](#), page 4-25
- [Security Intelligence Source/Destination Record](#), page 4-31

For metadata records for intrusion and correlation events, see [Intrusion Event and Metadata Record Types](#), page 3-1.

## Fingerprint Record

The eStreamer service transmits the fingerprint metadata for an event within a Fingerprint record, the format of which is shown below. (Fingerprint metadata is sent when one of the metadata flags—bits 1, 14, 15, or 20 in the Request Flags field of a request message—is set. See [Request Flags](#), page 2-11.) Note that the Record Type field, which appears after the Message Length field, has a value of 54, indicating a Fingerprint record.

|                     |                        |   |   |   |   |   |   |   |   |   |    |    |    |    |    |    |                  |    |    |    |    |    |    |    |    |    |    |    |    |    |    |    |
|---------------------|------------------------|---|---|---|---|---|---|---|---|---|----|----|----|----|----|----|------------------|----|----|----|----|----|----|----|----|----|----|----|----|----|----|----|
| Byte                | 0                      |   |   |   |   |   |   |   | 1 |   |    |    |    |    |    |    | 2                |    |    |    |    |    |    |    | 3  |    |    |    |    |    |    |    |
| Bit                 | 0                      | 1 | 2 | 3 | 4 | 5 | 6 | 7 | 8 | 9 | 10 | 11 | 12 | 13 | 14 | 15 | 16               | 17 | 18 | 19 | 20 | 21 | 22 | 23 | 24 | 25 | 26 | 27 | 28 | 29 | 30 | 31 |
|                     | Header Version (1)     |   |   |   |   |   |   |   |   |   |    |    |    |    |    |    | Message Type (4) |    |    |    |    |    |    |    |    |    |    |    |    |    |    |    |
|                     | Message Length         |   |   |   |   |   |   |   |   |   |    |    |    |    |    |    |                  |    |    |    |    |    |    |    |    |    |    |    |    |    |    |    |
|                     | Record Type (54)       |   |   |   |   |   |   |   |   |   |    |    |    |    |    |    |                  |    |    |    |    |    |    |    |    |    |    |    |    |    |    |    |
|                     | Record Length          |   |   |   |   |   |   |   |   |   |    |    |    |    |    |    |                  |    |    |    |    |    |    |    |    |    |    |    |    |    |    |    |
| Fingerprint<br>UUID | Fingerprint UUID       |   |   |   |   |   |   |   |   |   |    |    |    |    |    |    |                  |    |    |    |    |    |    |    |    |    |    |    |    |    |    |    |
|                     | Fingerprint UUID cont. |   |   |   |   |   |   |   |   |   |    |    |    |    |    |    |                  |    |    |    |    |    |    |    |    |    |    |    |    |    |    |    |
|                     | Fingerprint UUID cont. |   |   |   |   |   |   |   |   |   |    |    |    |    |    |    |                  |    |    |    |    |    |    |    |    |    |    |    |    |    |    |    |
|                     | Fingerprint UUID cont. |   |   |   |   |   |   |   |   |   |    |    |    |    |    |    |                  |    |    |    |    |    |    |    |    |    |    |    |    |    |    |    |
|                     | OS Name Length         |   |   |   |   |   |   |   |   |   |    |    |    |    |    |    |                  |    |    |    |    |    |    |    |    |    |    |    |    |    |    |    |
|                     | OS Name...             |   |   |   |   |   |   |   |   |   |    |    |    |    |    |    |                  |    |    |    |    |    |    |    |    |    |    |    |    |    |    |    |

|                   |   |   |   |   |   |   |   |   |   |   |    |    |    |    |    |    |    |    |    |    |    |    |    |    |    |    |    |    |    |    |    |    |
|-------------------|---|---|---|---|---|---|---|---|---|---|----|----|----|----|----|----|----|----|----|----|----|----|----|----|----|----|----|----|----|----|----|----|
| Byte              | 0 |   |   |   |   |   |   |   | 1 |   |    |    |    |    |    |    | 2  |    |    |    |    |    |    |    | 3  |    |    |    |    |    |    |    |
| Bit               | 0 | 1 | 2 | 3 | 4 | 5 | 6 | 7 | 8 | 9 | 10 | 11 | 12 | 13 | 14 | 15 | 16 | 17 | 18 | 19 | 20 | 21 | 22 | 23 | 24 | 25 | 26 | 27 | 28 | 29 | 30 | 31 |
| OS Vendor Length  |   |   |   |   |   |   |   |   |   |   |    |    |    |    |    |    |    |    |    |    |    |    |    |    |    |    |    |    |    |    |    |    |
| OS Vendor...      |   |   |   |   |   |   |   |   |   |   |    |    |    |    |    |    |    |    |    |    |    |    |    |    |    |    |    |    |    |    |    |    |
| OS Version Length |   |   |   |   |   |   |   |   |   |   |    |    |    |    |    |    |    |    |    |    |    |    |    |    |    |    |    |    |    |    |    |    |
| OS Version...     |   |   |   |   |   |   |   |   |   |   |    |    |    |    |    |    |    |    |    |    |    |    |    |    |    |    |    |    |    |    |    |    |

The following table describes the fields in the Fingerprint record.

Table 4-2 Fingerprint Record Fields

| Field             | Data Type | Description  |
|-------------------|-----------|--|
| Fingerprint UUID  | uint8[16] | A fingerprint ID number that acts as a unique identifier for the operating system. |
| OS Name Length    | uint32    | The number of bytes included in the operating system name.                         |
| OS Name           | string    | The name of the operating system for the fingerprint.                              |
| OS Vendor Length  | uint32    | The number of bytes included in the operating system vendor name.                  |
| OS Vendor         | string    | The name of the operating system vendor for the fingerprint.                       |
| OS Version Length | uint32    | The number of bytes included in the operating system version.                      |
| OS Version        | string    | The version of the operating system for the fingerprint.                           |

## Client Application Record

The eStreamer service transmits the client application metadata for an event within a Client Application record, the format of which is shown below. (Client application metadata is sent when one of the metadata flags—bits 1, 14, 15, or 20 in the Request Flags field of a request message—is set. See [Request Flags, page 2-11](#).) Note that the Record Type field, which appears after the Message Length field, has a value of 55, indicating a Client Application record.

|                    |   |   |   |   |   |   |   |   |   |   |    |    |    |    |    |                  |    |    |    |    |    |    |    |    |    |    |    |    |    |    |    |    |
|--------------------|---|---|---|---|---|---|---|---|---|---|----|----|----|----|----|------------------|----|----|----|----|----|----|----|----|----|----|----|----|----|----|----|----|
| Byte               | 0 |   |   |   |   |   |   |   | 1 |   |    |    |    |    |    |                  | 2  |    |    |    |    |    |    |    | 3  |    |    |    |    |    |    |    |
| Bit                | 0 | 1 | 2 | 3 | 4 | 5 | 6 | 7 | 8 | 9 | 10 | 11 | 12 | 13 | 14 | 15               | 16 | 17 | 18 | 19 | 20 | 21 | 22 | 23 | 24 | 25 | 26 | 27 | 28 | 29 | 30 | 31 |
| Header Version (1) |   |   |   |   |   |   |   |   |   |   |    |    |    |    |    | Message Type (4) |    |    |    |    |    |    |    |    |    |    |    |    |    |    |    |    |
| Message Length     |   |   |   |   |   |   |   |   |   |   |    |    |    |    |    |                  |    |    |    |    |    |    |    |    |    |    |    |    |    |    |    |    |
| Record Type (55)   |   |   |   |   |   |   |   |   |   |   |    |    |    |    |    |                  |    |    |    |    |    |    |    |    |    |    |    |    |    |    |    |    |
| Record Length      |   |   |   |   |   |   |   |   |   |   |    |    |    |    |    |                  |    |    |    |    |    |    |    |    |    |    |    |    |    |    |    |    |
| Application ID     |   |   |   |   |   |   |   |   |   |   |    |    |    |    |    |                  |    |    |    |    |    |    |    |    |    |    |    |    |    |    |    |    |

|             |   |   |   |   |   |   |   |   |   |   |    |    |    |    |    |    |    |    |    |    |    |    |    |    |    |    |    |    |    |    |    |    |
|-------------|---|---|---|---|---|---|---|---|---|---|----|----|----|----|----|----|----|----|----|----|----|----|----|----|----|----|----|----|----|----|----|----|
| Byte        | 0 |   |   |   |   |   |   |   | 1 |   |    |    |    |    |    |    | 2  |    |    |    |    |    |    |    | 3  |    |    |    |    |    |    |    |
| Bit         | 0 | 1 | 2 | 3 | 4 | 5 | 6 | 7 | 8 | 9 | 10 | 11 | 12 | 13 | 14 | 15 | 16 | 17 | 18 | 19 | 20 | 21 | 22 | 23 | 24 | 25 | 26 | 27 | 28 | 29 | 30 | 31 |
| Name Length |   |   |   |   |   |   |   |   |   |   |    |    |    |    |    |    |    |    |    |    |    |    |    |    |    |    |    |    |    |    |    |    |
| Name...     |   |   |   |   |   |   |   |   |   |   |    |    |    |    |    |    |    |    |    |    |    |    |    |    |    |    |    |    |    |    |    |    |

The following table describes the fields in the Client Application record.

*Table 4-3 Client Application Record Fields*

| Field          | Data Type | Description   |
|----------------|-----------|---|
| Application ID | uint32    | The application ID number for the client application. |
| Name Length    | uint32    | The number of bytes included in the name.             |
| Name           | string    | The client application name.                          |

## Vulnerability Record

The eStreamer service transmits metadata containing vulnerability information for an event within a Vulnerability record, the format of which is shown below. (Vulnerability information is sent when one of the metadata flags—bits 1, 14, 15, or 20 in the Request Flags field of a request message—is set. See [Request Flags, page 2-11](#).) Note that the Record Type field, which appears after the Message Length field, has a value of 57, indicating a Vulnerability record.

|                         |   |   |   |   |   |   |   |        |   |   |    |    |    |    |    |                   |    |    |    |    |    |    |    |    |    |    |    |    |    |    |    |    |
|-------------------------|---|---|---|---|---|---|---|--------|---|---|----|----|----|----|----|-------------------|----|----|----|----|----|----|----|----|----|----|----|----|----|----|----|----|
| Byte                    | 0 |   |   |   |   |   |   |        | 1 |   |    |    |    |    |    |                   | 2  |    |    |    |    |    |    |    | 3  |    |    |    |    |    |    |    |
| Bit                     | 0 | 1 | 2 | 3 | 4 | 5 | 6 | 7      | 8 | 9 | 10 | 11 | 12 | 13 | 14 | 15                | 16 | 17 | 18 | 19 | 20 | 21 | 22 | 23 | 24 | 25 | 26 | 27 | 28 | 29 | 30 | 31 |
| Header Version (1)      |   |   |   |   |   |   |   |        |   |   |    |    |    |    |    | Message Type (4)  |    |    |    |    |    |    |    |    |    |    |    |    |    |    |    |    |
| Message Length          |   |   |   |   |   |   |   |        |   |   |    |    |    |    |    |                   |    |    |    |    |    |    |    |    |    |    |    |    |    |    |    |    |
| Record Type (57)        |   |   |   |   |   |   |   |        |   |   |    |    |    |    |    |                   |    |    |    |    |    |    |    |    |    |    |    |    |    |    |    |    |
| Record Length           |   |   |   |   |   |   |   |        |   |   |    |    |    |    |    |                   |    |    |    |    |    |    |    |    |    |    |    |    |    |    |    |    |
| Vulnerability ID        |   |   |   |   |   |   |   |        |   |   |    |    |    |    |    |                   |    |    |    |    |    |    |    |    |    |    |    |    |    |    |    |    |
| Impact                  |   |   |   |   |   |   |   |        |   |   |    |    |    |    |    |                   |    |    |    |    |    |    |    |    |    |    |    |    |    |    |    |    |
| Exploits                |   |   |   |   |   |   |   | Remote |   |   |    |    |    |    |    | Entry Date Length |    |    |    |    |    |    |    |    |    |    |    |    |    |    |    |    |
| Entry Date Length Cont. |   |   |   |   |   |   |   |        |   |   |    |    |    |    |    | Entry Date...     |    |    |    |    |    |    |    |    |    |    |    |    |    |    |    |    |
| Published Date Length   |   |   |   |   |   |   |   |        |   |   |    |    |    |    |    |                   |    |    |    |    |    |    |    |    |    |    |    |    |    |    |    |    |
| Published Date...       |   |   |   |   |   |   |   |        |   |   |    |    |    |    |    |                   |    |    |    |    |    |    |    |    |    |    |    |    |    |    |    |    |
| Modified Date Length    |   |   |   |   |   |   |   |        |   |   |    |    |    |    |    |                   |    |    |    |    |    |    |    |    |    |    |    |    |    |    |    |    |

| Byte | 0                            |   |   |   |   |   |   |   | 1 |   |    |    |    |    |    |    | 2  |    |    |    |    |    |    |    | 3  |    |    |    |    |    |    |    |
|------|------------------------------|---|---|---|---|---|---|---|---|---|----|----|----|----|----|----|----|----|----|----|----|----|----|----|----|----|----|----|----|----|----|----|
| Bit  | 0                            | 1 | 2 | 3 | 4 | 5 | 6 | 7 | 8 | 9 | 10 | 11 | 12 | 13 | 14 | 15 | 16 | 17 | 18 | 19 | 20 | 21 | 22 | 23 | 24 | 25 | 26 | 27 | 28 | 29 | 30 | 31 |
|      | Modified Date...             |   |   |   |   |   |   |   |   |   |    |    |    |    |    |    |    |    |    |    |    |    |    |    |    |    |    |    |    |    |    |    |
|      | Title Length                 |   |   |   |   |   |   |   |   |   |    |    |    |    |    |    |    |    |    |    |    |    |    |    |    |    |    |    |    |    |    |    |
|      | Title...                     |   |   |   |   |   |   |   |   |   |    |    |    |    |    |    |    |    |    |    |    |    |    |    |    |    |    |    |    |    |    |    |
|      | Short Description Length     |   |   |   |   |   |   |   |   |   |    |    |    |    |    |    |    |    |    |    |    |    |    |    |    |    |    |    |    |    |    |    |
|      | Short Description...         |   |   |   |   |   |   |   |   |   |    |    |    |    |    |    |    |    |    |    |    |    |    |    |    |    |    |    |    |    |    |    |
|      | Description Length           |   |   |   |   |   |   |   |   |   |    |    |    |    |    |    |    |    |    |    |    |    |    |    |    |    |    |    |    |    |    |    |
|      | Description...               |   |   |   |   |   |   |   |   |   |    |    |    |    |    |    |    |    |    |    |    |    |    |    |    |    |    |    |    |    |    |    |
|      | Technical Description Length |   |   |   |   |   |   |   |   |   |    |    |    |    |    |    |    |    |    |    |    |    |    |    |    |    |    |    |    |    |    |    |
|      | Technical Description...     |   |   |   |   |   |   |   |   |   |    |    |    |    |    |    |    |    |    |    |    |    |    |    |    |    |    |    |    |    |    |    |
|      | Solution Length              |   |   |   |   |   |   |   |   |   |    |    |    |    |    |    |    |    |    |    |    |    |    |    |    |    |    |    |    |    |    |    |
|      | Solution...                  |   |   |   |   |   |   |   |   |   |    |    |    |    |    |    |    |    |    |    |    |    |    |    |    |    |    |    |    |    |    |    |

The following table describes the fields in the Vulnerability record.

**Table 4-4** Vulnerability Record Fields

| Field             | Data Type | Description   |
|-------------------|-----------|---|
| Vulnerability ID  | uint32    | The vulnerability ID number.  |
| Impact            | uint32    | The vulnerability impact, corresponding to the impact level determined through correlation of intrusion data, host discovery events, and vulnerability assessments. The value can be from 1 to 10, with 10 being the most severe. The impact value of a vulnerability is determined by the writer of the Bugtraq entry. |
| Exploits          | uint8     | Indicates whether known exploits exist for the vulnerability. Possible values include: <ul style="list-style-type: none"> <li>0 — Yes</li> <li>1 — No</li> </ul>  |
| Remote            | uint8     | Indicates whether the vulnerability can be exploited across a network. Possible values include: <ul style="list-style-type: none"> <li>0 — Yes</li> <li>1 — No</li> <li>Blank — Vulnerability to remote exploits unknown</li> </ul>   |
| Entry Date Length | uint32    | The length of the entry date field.   |
| Entry Date        | string    | The date the vulnerability was entered in the database.   |

Table 4-4 Vulnerability Record Fields (continued)

| Field                        | Data Type | Description   |
|------------------------------|-----------|---|
| Published Date Length        | uint32    | The length of the published date field.                                       |
| Published Date               | string    | The date the vulnerability was published.                                     |
| Modified Date Length         | uint32    | The length of the modified date field.  |
| Modified Date                | string    | The date of the most recent modification to the vulnerability, if applicable. |
| Title Length                 | uint32    | The length of the title field.  |
| Title                        | string    | The title of the vulnerability.   |
| Short Description Length     | uint32    | The length of the short description field.                                    |
| Short Description            | string    | A summary description of the vulnerability.                                   |
| Description Length           | uint32    | The length of the description field.  |
| Description                  | string    | A general description of the vulnerability.                                   |
| Technical Description Length | uint32    | The length of the technical description field.                                |
| Technical Description        | string    | The technical description of the vulnerability.                               |
| Solution Length              | uint32    | The length of the solution field.   |
| Solution                     | string    | The solution to the vulnerability.  |

## Criticality Record

The eStreamer service transmits metadata containing host criticality information for an event within a Criticality record, the format of which is shown below. (Criticality information is sent when one of the metadata flags—bits 1, 14, 15, or 20 in the Request Flags field of a request message—is set. See [Request Flags, page 2-11](#).) Note that the Record Type field, which appears after the Message Length field, has a value of 58, indicating a Criticality record.

| Byte | 0                  |   |   |   |   |   |   |   | 1 |   |    |    |    |    |    |    | 2                |    |    |    |    |    |    |    | 3  |    |    |    |    |    |    |    |
|------|--------------------|---|---|---|---|---|---|---|---|---|----|----|----|----|----|----|------------------|----|----|----|----|----|----|----|----|----|----|----|----|----|----|----|
| Bit  | 0                  | 1 | 2 | 3 | 4 | 5 | 6 | 7 | 8 | 9 | 10 | 11 | 12 | 13 | 14 | 15 | 16               | 17 | 18 | 19 | 20 | 21 | 22 | 23 | 24 | 25 | 26 | 27 | 28 | 29 | 30 | 31 |
|      | Header Version (1) |   |   |   |   |   |   |   |   |   |    |    |    |    |    |    | Message Type (4) |    |    |    |    |    |    |    |    |    |    |    |    |    |    |    |
|      | Message Length     |   |   |   |   |   |   |   |   |   |    |    |    |    |    |    |                  |    |    |    |    |    |    |    |    |    |    |    |    |    |    |    |
|      | Record Type (58)   |   |   |   |   |   |   |   |   |   |    |    |    |    |    |    |                  |    |    |    |    |    |    |    |    |    |    |    |    |    |    |    |
|      | Record Length      |   |   |   |   |   |   |   |   |   |    |    |    |    |    |    |                  |    |    |    |    |    |    |    |    |    |    |    |    |    |    |    |
|      | Criticality ID     |   |   |   |   |   |   |   |   |   |    |    |    |    |    |    |                  |    |    |    |    |    |    |    |    |    |    |    |    |    |    |    |

|             |   |   |   |   |   |   |   |   |   |   |    |    |    |    |    |    |    |    |    |    |    |    |    |    |    |    |    |    |    |    |    |    |
|-------------|---|---|---|---|---|---|---|---|---|---|----|----|----|----|----|----|----|----|----|----|----|----|----|----|----|----|----|----|----|----|----|----|
| Byte        | 0 |   |   |   |   |   |   |   | 1 |   |    |    |    |    |    |    | 2  |    |    |    |    |    |    |    | 3  |    |    |    |    |    |    |    |
| Bit         | 0 | 1 | 2 | 3 | 4 | 5 | 6 | 7 | 8 | 9 | 10 | 11 | 12 | 13 | 14 | 15 | 16 | 17 | 18 | 19 | 20 | 21 | 22 | 23 | 24 | 25 | 26 | 27 | 28 | 29 | 30 | 31 |
| Name Length |   |   |   |   |   |   |   |   |   |   |    |    |    |    |    |    |    |    |    |    |    |    |    |    |    |    |    |    |    |    |    |    |
| Name...     |   |   |   |   |   |   |   |   |   |   |    |    |    |    |    |    |    |    |    |    |    |    |    |    |    |    |    |    |    |    |    |    |

The following table describes the fields in the Criticality record.

**Table 4-5** Criticality Record Fields

| Field          | Data Type | Description  |
|----------------|-----------|--|
| Criticality ID | uint32    | The criticality ID number.                             |
| Name Length    | uint32    | The number of bytes included in the criticality level. |
| Name           | string    | The criticality level.                                 |

## Network Protocol Record

The eStreamer service transmits metadata containing network protocol information for an event within a Network Protocol record, the format of which is shown below. (Network protocol information is sent when one of the metadata flags—bits 1, 14, 15, or 20 in the Request Flags field of a request message—is set. See [Request Flags, page 2-11](#).) Note that the Record Type field, which appears after the Message Length field, has a value of 59, indicating a Network Protocol record.

|                     |   |   |   |   |   |   |   |   |   |   |    |    |    |    |    |                  |    |    |    |    |    |    |    |    |    |    |    |    |    |    |    |    |
|---------------------|---|---|---|---|---|---|---|---|---|---|----|----|----|----|----|------------------|----|----|----|----|----|----|----|----|----|----|----|----|----|----|----|----|
| Byte                | 0 |   |   |   |   |   |   |   | 1 |   |    |    |    |    |    |                  | 2  |    |    |    |    |    |    |    | 3  |    |    |    |    |    |    |    |
| Bit                 | 0 | 1 | 2 | 3 | 4 | 5 | 6 | 7 | 8 | 9 | 10 | 11 | 12 | 13 | 14 | 15               | 16 | 17 | 18 | 19 | 20 | 21 | 22 | 23 | 24 | 25 | 26 | 27 | 28 | 29 | 30 | 31 |
| Header Version (1)  |   |   |   |   |   |   |   |   |   |   |    |    |    |    |    | Message Type (4) |    |    |    |    |    |    |    |    |    |    |    |    |    |    |    |    |
| Message Length      |   |   |   |   |   |   |   |   |   |   |    |    |    |    |    |                  |    |    |    |    |    |    |    |    |    |    |    |    |    |    |    |    |
| Record Type (59)    |   |   |   |   |   |   |   |   |   |   |    |    |    |    |    |                  |    |    |    |    |    |    |    |    |    |    |    |    |    |    |    |    |
| Record Length       |   |   |   |   |   |   |   |   |   |   |    |    |    |    |    |                  |    |    |    |    |    |    |    |    |    |    |    |    |    |    |    |    |
| Network Protocol ID |   |   |   |   |   |   |   |   |   |   |    |    |    |    |    |                  |    |    |    |    |    |    |    |    |    |    |    |    |    |    |    |    |
| Name Length         |   |   |   |   |   |   |   |   |   |   |    |    |    |    |    |                  |    |    |    |    |    |    |    |    |    |    |    |    |    |    |    |    |
| Name...             |   |   |   |   |   |   |   |   |   |   |    |    |    |    |    |                  |    |    |    |    |    |    |    |    |    |    |    |    |    |    |    |    |

The following table describes the fields in the Network Protocol record.



**Table 4-6** Network Protocol Record Fields

| Field               | Data Type | Description  |
|---------------------|-----------|--|
| Network Protocol ID | uint32    | The network protocol ID number.                            |
| Name Length         | uint32    | The number of bytes included in the network protocol name. |
| Name                | string    | The name of the network protocol.                          |

## Attribute Record

The eStreamer service transmits metadata containing attribute information for an event within an Attribute record, the format of which is shown below. (Attribute information is sent when one of the metadata flags—bits 1, 14, 15, or 20 in the Request Flags field of a request message—is set. See [Request Flags, page 2-11](#).) Note that the Record Type field, which appears after the Message Length field, has a value of 60, indicating an Attribute record.

| Byte               | 0 |   |   |   |   |   |   |   | 1 |   |    |    |    |    |    |                  | 2  |    |    |    |    |    |    |    | 3  |    |    |    |    |    |    |    |
|--------------------|---|---|---|---|---|---|---|---|---|---|----|----|----|----|----|------------------|----|----|----|----|----|----|----|----|----|----|----|----|----|----|----|----|
| Bit                | 0 | 1 | 2 | 3 | 4 | 5 | 6 | 7 | 8 | 9 | 10 | 11 | 12 | 13 | 14 | 15               | 16 | 17 | 18 | 19 | 20 | 21 | 22 | 23 | 24 | 25 | 26 | 27 | 28 | 29 | 30 | 31 |
| Header Version (1) |   |   |   |   |   |   |   |   |   |   |    |    |    |    |    | Message Type (4) |    |    |    |    |    |    |    |    |    |    |    |    |    |    |    |    |
| Message Length     |   |   |   |   |   |   |   |   |   |   |    |    |    |    |    |                  |    |    |    |    |    |    |    |    |    |    |    |    |    |    |    |    |
| Record Type (60)   |   |   |   |   |   |   |   |   |   |   |    |    |    |    |    |                  |    |    |    |    |    |    |    |    |    |    |    |    |    |    |    |    |
| Record Length      |   |   |   |   |   |   |   |   |   |   |    |    |    |    |    |                  |    |    |    |    |    |    |    |    |    |    |    |    |    |    |    |    |
| Attribute ID       |   |   |   |   |   |   |   |   |   |   |    |    |    |    |    |                  |    |    |    |    |    |    |    |    |    |    |    |    |    |    |    |    |
| Name Length        |   |   |   |   |   |   |   |   |   |   |    |    |    |    |    |                  |    |    |    |    |    |    |    |    |    |    |    |    |    |    |    |    |
| Name...            |   |   |   |   |   |   |   |   |   |   |    |    |    |    |    |                  |    |    |    |    |    |    |    |    |    |    |    |    |    |    |    |    |

The following table describes the fields in the Attribute record.

**Table 4-7** Attribute Record Fields

| Field        | Data Type | Description   |
|--------------|-----------|---|
| Attribute ID | uint32    | The attribute ID number.                            |
| Name Length  | uint32    | The number of bytes included in the attribute name. |
| Name         | string    | The name of the attribute.                          |

## Scan Type Record

The eStreamer service transmits metadata containing scan type information for an event within a Scan Type record, the format of which is shown below. (Scan type information is sent when one of the metadata flags—bits 1, 14, 15, or 20 in the Request Flags field of a request message—is set. See [Request Flags, page 2-11](#).) Note that the Record Type field, which appears after the Message Length field, has a value of 61, indicating a Scan Type record.

|      |                    |   |   |   |   |   |   |   |   |   |    |    |    |    |    |    |                  |    |    |    |    |    |    |    |    |    |    |    |    |    |    |    |
|------|--------------------|---|---|---|---|---|---|---|---|---|----|----|----|----|----|----|------------------|----|----|----|----|----|----|----|----|----|----|----|----|----|----|----|
| Byte | 0                  |   |   |   |   |   |   |   | 1 |   |    |    |    |    |    |    | 2                |    |    |    |    |    |    |    | 3  |    |    |    |    |    |    |    |
| Bit  | 0                  | 1 | 2 | 3 | 4 | 5 | 6 | 7 | 8 | 9 | 10 | 11 | 12 | 13 | 14 | 15 | 16               | 17 | 18 | 19 | 20 | 21 | 22 | 23 | 24 | 25 | 26 | 27 | 28 | 29 | 30 | 31 |
|      | Header Version (1) |   |   |   |   |   |   |   |   |   |    |    |    |    |    |    | Message Type (4) |    |    |    |    |    |    |    |    |    |    |    |    |    |    |    |
|      | Message Length     |   |   |   |   |   |   |   |   |   |    |    |    |    |    |    |                  |    |    |    |    |    |    |    |    |    |    |    |    |    |    |    |
|      | Record Type (61)   |   |   |   |   |   |   |   |   |   |    |    |    |    |    |    |                  |    |    |    |    |    |    |    |    |    |    |    |    |    |    |    |
|      | Record Length      |   |   |   |   |   |   |   |   |   |    |    |    |    |    |    |                  |    |    |    |    |    |    |    |    |    |    |    |    |    |    |    |
|      | Scan Type ID       |   |   |   |   |   |   |   |   |   |    |    |    |    |    |    |                  |    |    |    |    |    |    |    |    |    |    |    |    |    |    |    |
|      | Name Length        |   |   |   |   |   |   |   |   |   |    |    |    |    |    |    |                  |    |    |    |    |    |    |    |    |    |    |    |    |    |    |    |
|      | Name...            |   |   |   |   |   |   |   |   |   |    |    |    |    |    |    |                  |    |    |    |    |    |    |    |    |    |    |    |    |    |    |    |

The following table describes the fields in the Scan Type record.

**Table 4-8** Scan Type Record Fields

| Field        | Data Type | Description   |
|--------------|-----------|---|
| Scan Type ID | uint32    | The scan type ID number.                            |
| Name Length  | uint32    | The number of bytes included in the scan type name. |
| Name         | string    | The name of the scan type.                          |

## Server Record

The eStreamer service transmits metadata containing server information for an event within a Server record, the format of which is shown below. The application ID of the server's application protocol provides the cross-reference to the metadata. (Server information is sent when one of the metadata flags—bits 1, 14, 15, or 20 in the Request Flags field of a request message—is set. See [Request Flags, page 2-11](#).) Note that the Record Type field, which appears after the Message Length field, has a value of 63, indicating a Server record.

|      |                    |   |   |   |   |   |   |   |   |   |    |    |    |    |    |    |                  |    |    |    |    |    |    |    |    |    |    |    |    |    |    |    |
|------|--------------------|---|---|---|---|---|---|---|---|---|----|----|----|----|----|----|------------------|----|----|----|----|----|----|----|----|----|----|----|----|----|----|----|
| Byte | 0                  |   |   |   |   |   |   |   | 1 |   |    |    |    |    |    |    | 2                |    |    |    |    |    |    |    | 3  |    |    |    |    |    |    |    |
| Bit  | 0                  | 1 | 2 | 3 | 4 | 5 | 6 | 7 | 8 | 9 | 10 | 11 | 12 | 13 | 14 | 15 | 16               | 17 | 18 | 19 | 20 | 21 | 22 | 23 | 24 | 25 | 26 | 27 | 28 | 29 | 30 | 31 |
|      | Header Version (1) |   |   |   |   |   |   |   |   |   |    |    |    |    |    |    | Message Type (4) |    |    |    |    |    |    |    |    |    |    |    |    |    |    |    |
|      | Message Length     |   |   |   |   |   |   |   |   |   |    |    |    |    |    |    |                  |    |    |    |    |    |    |    |    |    |    |    |    |    |    |    |
|      | Record Type (63)   |   |   |   |   |   |   |   |   |   |    |    |    |    |    |    |                  |    |    |    |    |    |    |    |    |    |    |    |    |    |    |    |
|      | Record Length      |   |   |   |   |   |   |   |   |   |    |    |    |    |    |    |                  |    |    |    |    |    |    |    |    |    |    |    |    |    |    |    |
|      | Application ID     |   |   |   |   |   |   |   |   |   |    |    |    |    |    |    |                  |    |    |    |    |    |    |    |    |    |    |    |    |    |    |    |
|      | Name Length        |   |   |   |   |   |   |   |   |   |    |    |    |    |    |    |                  |    |    |    |    |    |    |    |    |    |    |    |    |    |    |    |
|      | Name...            |   |   |   |   |   |   |   |   |   |    |    |    |    |    |    |                  |    |    |    |    |    |    |    |    |    |    |    |    |    |    |    |

The following table describes the fields in the Server record.

**Table 4-9** Server Record Fields

| Field          | Data Type | Description  |
|----------------|-----------|--|
| Application ID | uint32    | The application ID number of the application protocol.   |
| Name Length    | uint32    | The number of bytes included in the server name.   |
| Name           | string    | The name of the application protocol. For application ID 65535, the name is <code>unknown</code> . |

## Source Type Record

The eStreamer service transmits metadata containing information about the source application for an event within a Source Type record, the format of which is shown below. (Source type information is sent when one of the metadata flags—bits 1, 14, 15, or 20 in the Request Flags field of a request message—is set. See [Request Flags, page 2-11](#).) Note that the Record Type field, which appears after the Message Length field, has a value of 90, indicating a Source Type record.

|      |                    |   |   |   |   |   |   |   |   |   |    |    |    |    |    |    |                  |    |    |    |    |    |    |    |    |    |    |    |    |    |    |    |
|------|--------------------|---|---|---|---|---|---|---|---|---|----|----|----|----|----|----|------------------|----|----|----|----|----|----|----|----|----|----|----|----|----|----|----|
| Byte | 0                  |   |   |   |   |   |   |   | 1 |   |    |    |    |    |    |    | 2                |    |    |    |    |    |    |    | 3  |    |    |    |    |    |    |    |
| Bit  | 0                  | 1 | 2 | 3 | 4 | 5 | 6 | 7 | 8 | 9 | 10 | 11 | 12 | 13 | 14 | 15 | 16               | 17 | 18 | 19 | 20 | 21 | 22 | 23 | 24 | 25 | 26 | 27 | 28 | 29 | 30 | 31 |
|      | Header Version (1) |   |   |   |   |   |   |   |   |   |    |    |    |    |    |    | Message Type (4) |    |    |    |    |    |    |    |    |    |    |    |    |    |    |    |
|      | Message Length     |   |   |   |   |   |   |   |   |   |    |    |    |    |    |    |                  |    |    |    |    |    |    |    |    |    |    |    |    |    |    |    |
|      | Record Type (90)   |   |   |   |   |   |   |   |   |   |    |    |    |    |    |    |                  |    |    |    |    |    |    |    |    |    |    |    |    |    |    |    |
|      | Record Length      |   |   |   |   |   |   |   |   |   |    |    |    |    |    |    |                  |    |    |    |    |    |    |    |    |    |    |    |    |    |    |    |
|      | Source Type ID     |   |   |   |   |   |   |   |   |   |    |    |    |    |    |    |                  |    |    |    |    |    |    |    |    |    |    |    |    |    |    |    |

|             |   |   |   |   |   |   |   |   |   |   |    |    |    |    |    |    |    |    |    |    |    |    |    |    |    |    |    |    |    |    |    |    |
|-------------|---|---|---|---|---|---|---|---|---|---|----|----|----|----|----|----|----|----|----|----|----|----|----|----|----|----|----|----|----|----|----|----|
| Byte        | 0 |   |   |   |   |   |   |   | 1 |   |    |    |    |    |    |    | 2  |    |    |    |    |    |    |    | 3  |    |    |    |    |    |    |    |
| Bit         | 0 | 1 | 2 | 3 | 4 | 5 | 6 | 7 | 8 | 9 | 10 | 11 | 12 | 13 | 14 | 15 | 16 | 17 | 18 | 19 | 20 | 21 | 22 | 23 | 24 | 25 | 26 | 27 | 28 | 29 | 30 | 31 |
| Name Length |   |   |   |   |   |   |   |   |   |   |    |    |    |    |    |    |    |    |    |    |    |    |    |    |    |    |    |    |    |    |    |    |
| Name...     |   |   |   |   |   |   |   |   |   |   |    |    |    |    |    |    |    |    |    |    |    |    |    |    |    |    |    |    |    |    |    |    |

The following table describes the fields in the Source Type record.

**Table 4-10** Source Type Record Fields

| Field          | Data Type | Description   |
|----------------|-----------|---|
| Source Type ID | uint32    | The identification number for the source type.        |
| Name Length    | uint32    | The number of bytes included in the source type name. |
| Name           | string    | The name of the source type.                          |

## Source Application Record

The eStreamer service transmits metadata containing information about the source application for a host discovery event within a Source Application record, the format of which is shown below. (Source application information is sent when one of the metadata flags—bits 1, 14, 15, or 20 in the Request Flags field of a request message—is set. See [Request Flags, page 2-11](#).) Note that the Record Type field, which appears after the Message Length field, has a value of 91, indicating a Source Application record.

|                       |   |   |   |   |   |   |   |   |   |   |    |    |    |    |    |                  |    |    |    |    |    |    |    |    |    |    |    |    |    |    |    |    |
|-----------------------|---|---|---|---|---|---|---|---|---|---|----|----|----|----|----|------------------|----|----|----|----|----|----|----|----|----|----|----|----|----|----|----|----|
| Byte                  | 0 |   |   |   |   |   |   |   | 1 |   |    |    |    |    |    |                  | 2  |    |    |    |    |    |    |    | 3  |    |    |    |    |    |    |    |
| Bit                   | 0 | 1 | 2 | 3 | 4 | 5 | 6 | 7 | 8 | 9 | 10 | 11 | 12 | 13 | 14 | 15               | 16 | 17 | 18 | 19 | 20 | 21 | 22 | 23 | 24 | 25 | 26 | 27 | 28 | 29 | 30 | 31 |
| Header Version (1)    |   |   |   |   |   |   |   |   |   |   |    |    |    |    |    | Message Type (4) |    |    |    |    |    |    |    |    |    |    |    |    |    |    |    |    |
| Message Length        |   |   |   |   |   |   |   |   |   |   |    |    |    |    |    |                  |    |    |    |    |    |    |    |    |    |    |    |    |    |    |    |    |
| Record Type (91)      |   |   |   |   |   |   |   |   |   |   |    |    |    |    |    |                  |    |    |    |    |    |    |    |    |    |    |    |    |    |    |    |    |
| Record Length         |   |   |   |   |   |   |   |   |   |   |    |    |    |    |    |                  |    |    |    |    |    |    |    |    |    |    |    |    |    |    |    |    |
| Source Application ID |   |   |   |   |   |   |   |   |   |   |    |    |    |    |    |                  |    |    |    |    |    |    |    |    |    |    |    |    |    |    |    |    |
| Name Length           |   |   |   |   |   |   |   |   |   |   |    |    |    |    |    |                  |    |    |    |    |    |    |    |    |    |    |    |    |    |    |    |    |
| Name...               |   |   |   |   |   |   |   |   |   |   |    |    |    |    |    |                  |    |    |    |    |    |    |    |    |    |    |    |    |    |    |    |    |

The following table describes the fields in the Source Application record.

Table 4-11 Source Application Record Fields

| Field                 | Data Type | Description  |
|-----------------------|-----------|--|
| Source Application ID | uint32    | The ID number for the source application.                    |
| Name Length           | uint32    | The number of bytes included in the source application name. |
| Name                  | string    | The name of the source application.                          |

## Source Detector Record

The eStreamer service transmits metadata containing information about the source application for a host discovery event within a Source Type record, the format of which is shown below. (Source type information is sent when one of the metadata flags—bits 1, 14, 15, or 20 in the Request Flags field of a request message—is set. See [Request Flags, page 2-11](#).) Note that the Record Type field, which appears after the Message Length field, has a value of 96, indicating a Source Detector record.

| Byte | 0                  |   |   |   |   |   |   |   | 1 |   |    |    |    |    |    |    | 2                |    |    |    |    |    |    |    | 3  |    |    |    |    |    |    |    |
|------|--------------------|---|---|---|---|---|---|---|---|---|----|----|----|----|----|----|------------------|----|----|----|----|----|----|----|----|----|----|----|----|----|----|----|
| Bit  | 0                  | 1 | 2 | 3 | 4 | 5 | 6 | 7 | 8 | 9 | 10 | 11 | 12 | 13 | 14 | 15 | 16               | 17 | 18 | 19 | 20 | 21 | 22 | 23 | 24 | 25 | 26 | 27 | 28 | 29 | 30 | 31 |
|      | Header Version (1) |   |   |   |   |   |   |   |   |   |    |    |    |    |    |    | Message Type (4) |    |    |    |    |    |    |    |    |    |    |    |    |    |    |    |
|      | Message Length     |   |   |   |   |   |   |   |   |   |    |    |    |    |    |    |                  |    |    |    |    |    |    |    |    |    |    |    |    |    |    |    |
|      | Record Type (96)   |   |   |   |   |   |   |   |   |   |    |    |    |    |    |    |                  |    |    |    |    |    |    |    |    |    |    |    |    |    |    |    |
|      | Record Length      |   |   |   |   |   |   |   |   |   |    |    |    |    |    |    |                  |    |    |    |    |    |    |    |    |    |    |    |    |    |    |    |
|      | Source Detector ID |   |   |   |   |   |   |   |   |   |    |    |    |    |    |    |                  |    |    |    |    |    |    |    |    |    |    |    |    |    |    |    |
|      | Name Length        |   |   |   |   |   |   |   |   |   |    |    |    |    |    |    |                  |    |    |    |    |    |    |    |    |    |    |    |    |    |    |    |
|      | Name...            |   |   |   |   |   |   |   |   |   |    |    |    |    |    |    |                  |    |    |    |    |    |    |    |    |    |    |    |    |    |    |    |

The following table describes the fields in the Source Detector record.

Table 4-12 Source Detector Record Fields

| Field              | Data Type | Description   |
|--------------------|-----------|---|
| Source Detector ID | uint32    | The ID string for the source detector.                |
| Name Length        | uint32    | The number of bytes included in the source type name. |
| Name               | string    | The name of the source detector.                      |

## Third Party Scanner Vulnerability Record

The eStreamer service transmits metadata containing third-party vulnerability information for an event within a Third Party Scanner Vulnerability record, the format of which is shown below. (Vulnerability information is sent when one of the metadata flags—bits 1, 14, 15, or 20 in the Request Flags field of a request message—is set. See [Request Flags, page 2-11](#).) Note that the Record Type field, which appears

after the Message Length field, has a value of 106, indicating a Third Party Scanner Vulnerability record.

| Byte | 0                  |   |   |   |   |   |   |   | 1 |   |    |    |    |    |    |    | 2                |    |    |    |    |    |    |    | 3  |    |    |    |    |    |    |    |
|------|--------------------|---|---|---|---|---|---|---|---|---|----|----|----|----|----|----|------------------|----|----|----|----|----|----|----|----|----|----|----|----|----|----|----|
| Bit  | 0                  | 1 | 2 | 3 | 4 | 5 | 6 | 7 | 8 | 9 | 10 | 11 | 12 | 13 | 14 | 15 | 16               | 17 | 18 | 19 | 20 | 21 | 22 | 23 | 24 | 25 | 26 | 27 | 28 | 29 | 30 | 31 |
|      | Header Version (1) |   |   |   |   |   |   |   |   |   |    |    |    |    |    |    | Message Type (4) |    |    |    |    |    |    |    |    |    |    |    |    |    |    |    |
|      | Message Length     |   |   |   |   |   |   |   |   |   |    |    |    |    |    |    |                  |    |    |    |    |    |    |    |    |    |    |    |    |    |    |    |
|      | Record Type (106)  |   |   |   |   |   |   |   |   |   |    |    |    |    |    |    |                  |    |    |    |    |    |    |    |    |    |    |    |    |    |    |    |
|      | Record Length      |   |   |   |   |   |   |   |   |   |    |    |    |    |    |    |                  |    |    |    |    |    |    |    |    |    |    |    |    |    |    |    |
|      | Vulnerability ID   |   |   |   |   |   |   |   |   |   |    |    |    |    |    |    |                  |    |    |    |    |    |    |    |    |    |    |    |    |    |    |    |
|      | Scanner Type       |   |   |   |   |   |   |   |   |   |    |    |    |    |    |    |                  |    |    |    |    |    |    |    |    |    |    |    |    |    |    |    |
|      | Title Length       |   |   |   |   |   |   |   |   |   |    |    |    |    |    |    |                  |    |    |    |    |    |    |    |    |    |    |    |    |    |    |    |
|      | Title...           |   |   |   |   |   |   |   |   |   |    |    |    |    |    |    |                  |    |    |    |    |    |    |    |    |    |    |    |    |    |    |    |
|      | Description Length |   |   |   |   |   |   |   |   |   |    |    |    |    |    |    |                  |    |    |    |    |    |    |    |    |    |    |    |    |    |    |    |
|      | Description...     |   |   |   |   |   |   |   |   |   |    |    |    |    |    |    |                  |    |    |    |    |    |    |    |    |    |    |    |    |    |    |    |
|      | CVE ID Length      |   |   |   |   |   |   |   |   |   |    |    |    |    |    |    |                  |    |    |    |    |    |    |    |    |    |    |    |    |    |    |    |
|      | CVE ID...          |   |   |   |   |   |   |   |   |   |    |    |    |    |    |    |                  |    |    |    |    |    |    |    |    |    |    |    |    |    |    |    |
|      | BugTraQ Length     |   |   |   |   |   |   |   |   |   |    |    |    |    |    |    |                  |    |    |    |    |    |    |    |    |    |    |    |    |    |    |    |
|      | BugTraQ ID...      |   |   |   |   |   |   |   |   |   |    |    |    |    |    |    |                  |    |    |    |    |    |    |    |    |    |    |    |    |    |    |    |

The following table describes the fields in the Vulnerability record.

**Table 4-13** Third Party Scanner Vulnerability Record Fields

| Field              | Data Type | Description   |
|--------------------|-----------|---|
| Vulnerability ID   | uint32    | The third-party vulnerability ID number.  |
| Scanner Type       | uint32    | The third-party scanner type.   |
| Title Length       | uint32    | The length of the title field.  |
| Title              | string    | The title of the vulnerability.   |
| Description Length | uint32    | The length of the description field.  |
| Description        | string    | A general description of the vulnerability.                                     |
| CVE ID Length      | uint32    | The length of the CVE ID field.   |
| CVE ID             | string    | The Common Vulnerabilities and Exposures (CVE) ID number for the vulnerability. |

Table 4-13 Third Party Scanner Vulnerability Record Fields (continued)

| Field             | Data Type | Description                                  |
|-------------------|-----------|--|
| BugTraq ID Length | uint32    | The length of the BugTraq ID field.          |
| BugTraq ID        | string    | The BugTraq ID number for the vulnerability. |

## User Record

The eStreamer service transmits metadata containing information about users detected by the system within a User record, the format of which is shown below. (User information is sent when the Version 4 metadata and the policy event request flag—bits 20 and 22, respectively, in the Request Flags field of a request message—is set. See [Request Flags, page 2-11](#).) Note that the Record Type field, which appears after the Message Length field, has a value of 98, indicating a User record.

| Byte | 0                  |   |   |   |   |   |   |   | 1 |   |    |    |    |    |    |    | 2                |    |    |    |    |    |    |    | 3  |    |    |    |    |    |    |    |
|------|--------------------|---|---|---|---|---|---|---|---|---|----|----|----|----|----|----|------------------|----|----|----|----|----|----|----|----|----|----|----|----|----|----|----|
| Bit  | 0                  | 1 | 2 | 3 | 4 | 5 | 6 | 7 | 8 | 9 | 10 | 11 | 12 | 13 | 14 | 15 | 16               | 17 | 18 | 19 | 20 | 21 | 22 | 23 | 24 | 25 | 26 | 27 | 28 | 29 | 30 | 31 |
|      | Header Version (1) |   |   |   |   |   |   |   |   |   |    |    |    |    |    |    | Message Type (4) |    |    |    |    |    |    |    |    |    |    |    |    |    |    |    |
|      | Message Length     |   |   |   |   |   |   |   |   |   |    |    |    |    |    |    |                  |    |    |    |    |    |    |    |    |    |    |    |    |    |    |    |
|      | Record Type (98)   |   |   |   |   |   |   |   |   |   |    |    |    |    |    |    |                  |    |    |    |    |    |    |    |    |    |    |    |    |    |    |    |
|      | Record Length      |   |   |   |   |   |   |   |   |   |    |    |    |    |    |    |                  |    |    |    |    |    |    |    |    |    |    |    |    |    |    |    |
|      | User ID            |   |   |   |   |   |   |   |   |   |    |    |    |    |    |    |                  |    |    |    |    |    |    |    |    |    |    |    |    |    |    |    |
|      | Protocol           |   |   |   |   |   |   |   |   |   |    |    |    |    |    |    |                  |    |    |    |    |    |    |    |    |    |    |    |    |    |    |    |
|      | Name Length        |   |   |   |   |   |   |   |   |   |    |    |    |    |    |    |                  |    |    |    |    |    |    |    |    |    |    |    |    |    |    |    |
|      | Name...            |   |   |   |   |   |   |   |   |   |    |    |    |    |    |    |                  |    |    |    |    |    |    |    |    |    |    |    |    |    |    |    |

The following table describes the fields in the User record.

Table 4-14 User Record Fields

| Field       | Data Type | Description   |
|-------------|-----------|---|
| User ID     | uint32    | The ID string for the user.                               |
| Protocol    | uint32    | The protocol for the traffic where the user was detected. |
| Name Length | uint32    | The number of bytes included in the user name.            |
| Name        | string    | The name of the user.                                     |

## Web Application Record

The system detects the content of HTTP traffic from websites, if available. Web application metadata for a host discovery event may include the specific type of content (for example, WMV or QuickTime).

The eStreamer service transmits the web application metadata for an event within a Web Application record, the format of which is shown below. (Web application metadata is sent when one of the metadata flags—bits 1, 14, 15, or 20 in the Request Flags field of a request message—is set. See [Request Flags, page 2-11](#).) Note that the Record Type field, which appears after the Message Length field, has a value of 109, indicating a Web Application record.

|      |                    |   |   |   |   |   |   |   |   |   |    |    |    |    |    |    |                  |    |    |    |    |    |    |    |    |    |    |    |    |    |    |    |
|------|--------------------|---|---|---|---|---|---|---|---|---|----|----|----|----|----|----|------------------|----|----|----|----|----|----|----|----|----|----|----|----|----|----|----|
| Byte | 0                  |   |   |   |   |   |   |   | 1 |   |    |    |    |    |    |    | 2                |    |    |    |    |    |    |    | 3  |    |    |    |    |    |    |    |
| Bit  | 0                  | 1 | 2 | 3 | 4 | 5 | 6 | 7 | 8 | 9 | 10 | 11 | 12 | 13 | 14 | 15 | 16               | 17 | 18 | 19 | 20 | 21 | 22 | 23 | 24 | 25 | 26 | 27 | 28 | 29 | 30 | 31 |
|      | Header Version (1) |   |   |   |   |   |   |   |   |   |    |    |    |    |    |    | Message Type (4) |    |    |    |    |    |    |    |    |    |    |    |    |    |    |    |
|      | Message Length     |   |   |   |   |   |   |   |   |   |    |    |    |    |    |    |                  |    |    |    |    |    |    |    |    |    |    |    |    |    |    |    |
|      | Record Type (109)  |   |   |   |   |   |   |   |   |   |    |    |    |    |    |    |                  |    |    |    |    |    |    |    |    |    |    |    |    |    |    |    |
|      | Record Length      |   |   |   |   |   |   |   |   |   |    |    |    |    |    |    |                  |    |    |    |    |    |    |    |    |    |    |    |    |    |    |    |
|      | Application ID     |   |   |   |   |   |   |   |   |   |    |    |    |    |    |    |                  |    |    |    |    |    |    |    |    |    |    |    |    |    |    |    |
|      | Name Length        |   |   |   |   |   |   |   |   |   |    |    |    |    |    |    |                  |    |    |    |    |    |    |    |    |    |    |    |    |    |    |    |
|      | Name...            |   |   |   |   |   |   |   |   |   |    |    |    |    |    |    |                  |    |    |    |    |    |    |    |    |    |    |    |    |    |    |    |

The following table describes the fields in the Web Application record.

**Table 4-15** Web Application Record Fields

| Field          | Data Type | Description                                   |
|----------------|-----------|---|
| Application ID | uint32    | Application ID number of the web application. |
| Name Length    | uint32    | The number of bytes included in the name.     |
| Name           | string    | The web application content name.             |

## Intrusion Policy Name Record

The eStreamer service transmits metadata containing intrusion policy name information for a connection event within an Intrusion Policy Name record, the format of which is shown below. (Intrusion policy name information is sent when one of the metadata flags—version 4 metadata bit 20 in the Request Flags field of a request message—is set. See [Request Flags, page 2-11](#).) Note that the Intrusion Policy Name record field, which appears after the Message Length field, has a value of 118, indicating an Intrusion Policy Name record. It contains a UUID String data block, block type 14 in the series 2 set of data blocks.

|      |                    |   |   |   |   |   |   |   |   |   |    |    |    |    |    |    |                  |    |    |    |    |    |    |    |    |    |    |    |    |    |    |    |
|------|--------------------|---|---|---|---|---|---|---|---|---|----|----|----|----|----|----|------------------|----|----|----|----|----|----|----|----|----|----|----|----|----|----|----|
| Byte | 0                  |   |   |   |   |   |   |   | 1 |   |    |    |    |    |    |    | 2                |    |    |    |    |    |    |    | 3  |    |    |    |    |    |    |    |
| Bit  | 0                  | 1 | 2 | 3 | 4 | 5 | 6 | 7 | 8 | 9 | 10 | 11 | 12 | 13 | 14 | 15 | 16               | 17 | 18 | 19 | 20 | 21 | 22 | 23 | 24 | 25 | 26 | 27 | 28 | 29 | 30 | 31 |
|      | Header Version (1) |   |   |   |   |   |   |   |   |   |    |    |    |    |    |    | Message Type (4) |    |    |    |    |    |    |    |    |    |    |    |    |    |    |    |
|      | Message Length     |   |   |   |   |   |   |   |   |   |    |    |    |    |    |    |                  |    |    |    |    |    |    |    |    |    |    |    |    |    |    |    |



| Byte                                    | 0 |   |   |   |   |   |   |   | 1 |   |    |    |    |    |    |    | 2  |    |    |    |    |    |    |    | 3  |    |    |    |    |    |    |    |
|---|---|---|---|---|---|---|---|---|---|---|----|----|----|----|----|----|----|----|----|----|----|----|----|----|----|----|----|----|----|----|----|----|
| Bit                                     | 0 | 1 | 2 | 3 | 4 | 5 | 6 | 7 | 8 | 9 | 10 | 11 | 12 | 13 | 14 | 15 | 16 | 17 | 18 | 19 | 20 | 21 | 22 | 23 | 24 | 25 | 26 | 27 | 28 | 29 | 30 | 31 |
| Record Type (118)                       |   |   |   |   |   |   |   |   |   |   |    |    |    |    |    |    |    |    |    |    |    |    |    |    |    |    |    |    |    |    |    |    |
| Record Length                           |   |   |   |   |   |   |   |   |   |   |    |    |    |    |    |    |    |    |    |    |    |    |    |    |    |    |    |    |    |    |    |    |
| Intrusion Policy Name Data Block (14)   |   |   |   |   |   |   |   |   |   |   |    |    |    |    |    |    |    |    |    |    |    |    |    |    |    |    |    |    |    |    |    |    |
| Intrusion Policy Name Data Block Length |   |   |   |   |   |   |   |   |   |   |    |    |    |    |    |    |    |    |    |    |    |    |    |    |    |    |    |    |    |    |    |    |
| Intrusion Policy UUID                   |   |   |   |   |   |   |   |   |   |   |    |    |    |    |    |    |    |    |    |    |    |    |    |    |    |    |    |    |    |    |    |    |
| Intrusion Policy UUID, continued        |   |   |   |   |   |   |   |   |   |   |    |    |    |    |    |    |    |    |    |    |    |    |    |    |    |    |    |    |    |    |    |    |
| Intrusion Policy UUID, continued        |   |   |   |   |   |   |   |   |   |   |    |    |    |    |    |    |    |    |    |    |    |    |    |    |    |    |    |    |    |    |    |    |
| Intrusion Policy UUID, continued        |   |   |   |   |   |   |   |   |   |   |    |    |    |    |    |    |    |    |    |    |    |    |    |    |    |    |    |    |    |    |    |    |
| String Block Type (0)                   |   |   |   |   |   |   |   |   |   |   |    |    |    |    |    |    |    |    |    |    |    |    |    |    |    |    |    |    |    |    |    |    |
| String Block Length                     |   |   |   |   |   |   |   |   |   |   |    |    |    |    |    |    |    |    |    |    |    |    |    |    |    |    |    |    |    |    |    |    |
| Intrusion Policy Name...                |   |   |   |   |   |   |   |   |   |   |    |    |    |    |    |    |    |    |    |    |    |    |    |    |    |    |    |    |    |    |    |    |

The following table describes the fields in the Intrusion Policy Name data block.

**Table 4-16** Intrusion Policy Name Data Block Fields

| Field                                   | Data Type | Description  |
|---|-----------|--|
| Intrusion Policy Name Data Block Type   | uint32    | Initiates an Intrusion Policy Name data block. This value is always 14. The block type is a series 2 block.  |
| Intrusion Policy Name Data Block Length | uint32    | Length of the data block. Includes the number of bytes of data plus the 8 bytes in the two data block header fields.   |
| Intrusion Policy UUID                   | uint8[16] | The unique identifier for the intrusion policy associated with the connection event.   |
| String Block Type                       | uint32    | Initiates a String data block containing the name of the intrusion policy. This value is always 0.   |
| String Block Length                     | uint32    | The number of bytes included in the intrusion policy name String data block, including eight bytes for the block type and header fields plus the number of bytes in the intrusion policy name. |
| Intrusion Policy Name                   | string    | The intrusion policy name.   |

## Access Control Rule Action Record Metadata

The eStreamer service transmits metadata containing the action associated with a triggered access control rule within an Access Control Rule Action record, the format of which is shown below. (Access Control Rule Action information is sent when the version 4 metadata flag—bit 20 in the Request Flags

field of a request message—is set. See [Request Flags, page 2-11](#).) Note that the Access Control Rule Action record field, which appears after the Message Length field, has a value of 120, indicating an Access Control Rule Action record.

|      |                               |   |   |   |   |   |   |   |   |   |    |    |    |    |    |    |                  |    |    |    |    |    |    |    |    |    |    |    |    |    |    |    |
|------|-------------------------------|---|---|---|---|---|---|---|---|---|----|----|----|----|----|----|------------------|----|----|----|----|----|----|----|----|----|----|----|----|----|----|----|
| Byte | 0                             |   |   |   |   |   |   |   | 1 |   |    |    |    |    |    |    | 2                |    |    |    |    |    |    |    | 3  |    |    |    |    |    |    |    |
| Bit  | 0                             | 1 | 2 | 3 | 4 | 5 | 6 | 7 | 8 | 9 | 10 | 11 | 12 | 13 | 14 | 15 | 16               | 17 | 18 | 19 | 20 | 21 | 22 | 23 | 24 | 25 | 26 | 27 | 28 | 29 | 30 | 31 |
|      | Header Version (1)            |   |   |   |   |   |   |   |   |   |    |    |    |    |    |    | Message Type (4) |    |    |    |    |    |    |    |    |    |    |    |    |    |    |    |
|      | Message Length                |   |   |   |   |   |   |   |   |   |    |    |    |    |    |    |                  |    |    |    |    |    |    |    |    |    |    |    |    |    |    |    |
|      | Record Type (120)             |   |   |   |   |   |   |   |   |   |    |    |    |    |    |    |                  |    |    |    |    |    |    |    |    |    |    |    |    |    |    |    |
|      | Record Length                 |   |   |   |   |   |   |   |   |   |    |    |    |    |    |    |                  |    |    |    |    |    |    |    |    |    |    |    |    |    |    |    |
|      | Access Control Rule Action ID |   |   |   |   |   |   |   |   |   |    |    |    |    |    |    |                  |    |    |    |    |    |    |    |    |    |    |    |    |    |    |    |
|      | Name Length                   |   |   |   |   |   |   |   |   |   |    |    |    |    |    |    |                  |    |    |    |    |    |    |    |    |    |    |    |    |    |    |    |
|      | Name...                       |   |   |   |   |   |   |   |   |   |    |    |    |    |    |    |                  |    |    |    |    |    |    |    |    |    |    |    |    |    |    |    |

The following table describes the fields in the Access Control Rule Action record.

**Table 4-17** Access Control Rule Action Record Fields

| Field                         | Data Type | Description                                  |
|-------------------------------|-----------|--|
| Access Control Rule Action ID | uint32    | ID number of the access control rule action. |
| Name Length                   | uint32    | The number of bytes included in the name.    |
| Name                          | string    | The firewall rule action name.               |

## URL Category Record Metadata

The eStreamer service transmits metadata containing the category name associated with a URL in a connection log within a URL Category record, the format of which is shown below. (URL category information is sent when the version 4 metadata flag—bit 20 in the Request Flags field of a request message—is set. See [Request Flags, page 2-11](#).) Note that the record field, which appears after the Message Length field, has a value of 121, indicating a URL Category record.

|      |                    |   |   |   |   |   |   |   |   |   |    |    |    |    |    |    |                  |    |    |    |    |    |    |    |    |    |    |    |    |    |    |    |
|------|--------------------|---|---|---|---|---|---|---|---|---|----|----|----|----|----|----|------------------|----|----|----|----|----|----|----|----|----|----|----|----|----|----|----|
| Byte | 0                  |   |   |   |   |   |   |   | 1 |   |    |    |    |    |    |    | 2                |    |    |    |    |    |    |    | 3  |    |    |    |    |    |    |    |
| Bit  | 0                  | 1 | 2 | 3 | 4 | 5 | 6 | 7 | 8 | 9 | 10 | 11 | 12 | 13 | 14 | 15 | 16               | 17 | 18 | 19 | 20 | 21 | 22 | 23 | 24 | 25 | 26 | 27 | 28 | 29 | 30 | 31 |
|      | Header Version (1) |   |   |   |   |   |   |   |   |   |    |    |    |    |    |    | Message Type (4) |    |    |    |    |    |    |    |    |    |    |    |    |    |    |    |
|      | Message Length     |   |   |   |   |   |   |   |   |   |    |    |    |    |    |    |                  |    |    |    |    |    |    |    |    |    |    |    |    |    |    |    |
|      | Record Type (121)  |   |   |   |   |   |   |   |   |   |    |    |    |    |    |    |                  |    |    |    |    |    |    |    |    |    |    |    |    |    |    |    |
|      | Record Length      |   |   |   |   |   |   |   |   |   |    |    |    |    |    |    |                  |    |    |    |    |    |    |    |    |    |    |    |    |    |    |    |

|                 |   |   |   |   |   |   |   |   |   |   |    |    |    |    |    |    |    |    |    |    |    |    |    |    |    |    |    |    |    |    |    |    |
|-----------------|---|---|---|---|---|---|---|---|---|---|----|----|----|----|----|----|----|----|----|----|----|----|----|----|----|----|----|----|----|----|----|----|
| Byte            | 0 |   |   |   |   |   |   |   | 1 |   |    |    |    |    |    |    | 2  |    |    |    |    |    |    |    | 3  |    |    |    |    |    |    |    |
| Bit             | 0 | 1 | 2 | 3 | 4 | 5 | 6 | 7 | 8 | 9 | 10 | 11 | 12 | 13 | 14 | 15 | 16 | 17 | 18 | 19 | 20 | 21 | 22 | 23 | 24 | 25 | 26 | 27 | 28 | 29 | 30 | 31 |
| URL Category ID |   |   |   |   |   |   |   |   |   |   |    |    |    |    |    |    |    |    |    |    |    |    |    |    |    |    |    |    |    |    |    |    |
| Name Length     |   |   |   |   |   |   |   |   |   |   |    |    |    |    |    |    |    |    |    |    |    |    |    |    |    |    |    |    |    |    |    |    |
| Name...         |   |   |   |   |   |   |   |   |   |   |    |    |    |    |    |    |    |    |    |    |    |    |    |    |    |    |    |    |    |    |    |    |

The following table describes the fields in the URL Category record.

*Table 4-18 URL Category Record Fields*

| Field           | Data Type | Description                               |
|-----------------|-----------|---|
| URL Category ID | uint32    | ID number of the URL category.            |
| Name Length     | uint32    | The number of bytes included in the name. |
| Name            | string    | The URL category name.                    |

## URL Reputation Record Metadata

The eStreamer service transmits metadata containing the reputation (that is, risk level) associated with a URL in a connection log within a URL Reputation record, the format of which is shown below. (URL reputation information is sent when the version 4 metadata flag—bit 20 in the Request Flags field of a request message—is set. See [Request Flags, page 2-11](#).) Note that the URL Reputation metadata record field, which appears after the Message Length field, has a value of 122, indicating a URL Reputation metadata record.

|                    |   |   |   |   |   |   |   |   |   |   |    |    |    |    |    |                  |    |    |    |    |    |    |    |    |    |    |    |    |    |    |    |    |
|--------------------|---|---|---|---|---|---|---|---|---|---|----|----|----|----|----|------------------|----|----|----|----|----|----|----|----|----|----|----|----|----|----|----|----|
| Byte               | 0 |   |   |   |   |   |   |   | 1 |   |    |    |    |    |    |                  | 2  |    |    |    |    |    |    |    | 3  |    |    |    |    |    |    |    |
| Bit                | 0 | 1 | 2 | 3 | 4 | 5 | 6 | 7 | 8 | 9 | 10 | 11 | 12 | 13 | 14 | 15               | 16 | 17 | 18 | 19 | 20 | 21 | 22 | 23 | 24 | 25 | 26 | 27 | 28 | 29 | 30 | 31 |
| Header Version (1) |   |   |   |   |   |   |   |   |   |   |    |    |    |    |    | Message Type (4) |    |    |    |    |    |    |    |    |    |    |    |    |    |    |    |    |
| Message Length     |   |   |   |   |   |   |   |   |   |   |    |    |    |    |    |                  |    |    |    |    |    |    |    |    |    |    |    |    |    |    |    |    |
| Record Type (122)  |   |   |   |   |   |   |   |   |   |   |    |    |    |    |    |                  |    |    |    |    |    |    |    |    |    |    |    |    |    |    |    |    |
| Record Length      |   |   |   |   |   |   |   |   |   |   |    |    |    |    |    |                  |    |    |    |    |    |    |    |    |    |    |    |    |    |    |    |    |
| URL Reputation ID  |   |   |   |   |   |   |   |   |   |   |    |    |    |    |    |                  |    |    |    |    |    |    |    |    |    |    |    |    |    |    |    |    |
| Name Length        |   |   |   |   |   |   |   |   |   |   |    |    |    |    |    |                  |    |    |    |    |    |    |    |    |    |    |    |    |    |    |    |    |
| Name...            |   |   |   |   |   |   |   |   |   |   |    |    |    |    |    |                  |    |    |    |    |    |    |    |    |    |    |    |    |    |    |    |    |

The following table describes the fields in the URL Reputation record.

**Table 4-19** URL Reputation Record Fields

| Field             | Data Type | Description                               |
|-------------------|-----------|---|
| URL Reputation ID | uint32    | ID number of the URL reputation.          |
| Name Length       | uint32    | The number of bytes included in the name. |
| Name              | string    | The URL reputation name.                  |

## Access Control Rule Reason Metadata

The eStreamer service transmits metadata containing information about the reason an access control rule triggered an intrusion event or connection event within an Access Control Rule Reason record, the format of which is shown below. Access control rule reason metadata is sent when the Version 4 metadata flag—bit 20 in the Request Flags field of a request message—is set. See [Request Flags, page 2-11](#). Note that the Record Type field, which appears after the Message Length field, has a value of 124, indicating an Access Control Rule Reason record. It contains an Access Control Rule Reason Block (as documented in [Access Control Rule Reason Data Block 5.1+, page 4-174](#)). The Access Control Rule Reason data block is block type 21 in series 2.

| Byte | 0  |   |   |   |   |   |   |   | 1 |   |    |    |    |    |    |    | 2                     |    |    |    |    |    |    |    | 3  |    |    |    |    |    |    |    |
|------|--|---|---|---|---|---|---|---|---|---|----|----|----|----|----|----|-----------------------|----|----|----|----|----|----|----|----|----|----|----|----|----|----|----|
| Bit  | 0  | 1 | 2 | 3 | 4 | 5 | 6 | 7 | 8 | 9 | 10 | 11 | 12 | 13 | 14 | 15 | 16                    | 17 | 18 | 19 | 20 | 21 | 22 | 23 | 24 | 25 | 26 | 27 | 28 | 29 | 30 | 31 |
|      | Header Version (1)                         |   |   |   |   |   |   |   |   |   |    |    |    |    |    |    | Message Type (4)      |    |    |    |    |    |    |    |    |    |    |    |    |    |    |    |
|      | Message Length                             |   |   |   |   |   |   |   |   |   |    |    |    |    |    |    |                       |    |    |    |    |    |    |    |    |    |    |    |    |    |    |    |
|      | Record Type (124)                          |   |   |   |   |   |   |   |   |   |    |    |    |    |    |    |                       |    |    |    |    |    |    |    |    |    |    |    |    |    |    |    |
|      | Record Length                              |   |   |   |   |   |   |   |   |   |    |    |    |    |    |    |                       |    |    |    |    |    |    |    |    |    |    |    |    |    |    |    |
|      | Access Control Rule Reason Block Type (21) |   |   |   |   |   |   |   |   |   |    |    |    |    |    |    |                       |    |    |    |    |    |    |    |    |    |    |    |    |    |    |    |
|      | Access Control Rule Block Length           |   |   |   |   |   |   |   |   |   |    |    |    |    |    |    |                       |    |    |    |    |    |    |    |    |    |    |    |    |    |    |    |
|      | Access Control Rule Reason                 |   |   |   |   |   |   |   |   |   |    |    |    |    |    |    | String Block Type (0) |    |    |    |    |    |    |    |    |    |    |    |    |    |    |    |
|      | String Block Type (0), cont.               |   |   |   |   |   |   |   |   |   |    |    |    |    |    |    | String Block Length   |    |    |    |    |    |    |    |    |    |    |    |    |    |    |    |
|      | String Block Length, cont.                 |   |   |   |   |   |   |   |   |   |    |    |    |    |    |    | Description...        |    |    |    |    |    |    |    |    |    |    |    |    |    |    |    |

The following table describes the fields in the Access Control Rule ID data block.

*Table 4-20 Access Control Rule Reason Metadata Fields*

| Field                                   | Data Type | Description  |
|---|-----------|--|
| Access Control Rule Reason Block Type   | uint32    | Initiates an Access Control Rule Reason block. This value is always 21. This is a series 2 data block.   |
| Access Control Rule Reason Block Length | uint32    | Total number of bytes in the Access Control Rule Reason block, including eight bytes for the Access Control Rule Reason block type and length fields, plus the number of bytes of data that follows. |
| Access Control Rule Reason              | uint16    | The reason the Access Control rule logged the connection.  |
| String Block Type                       | uint32    | Initiates a String data block containing the descriptive name associated with the access control rule reason. This value is always 0.  |
| String Block Length                     | uint32    | The number of bytes included in the name String data block, including eight bytes for the block type and header fields plus the number of bytes in the Description field.                            |
| Description                             | string    | Description of the Access Control rule reason.   |

### IOC State Data Block for 5.3+

The IOC State data block provides information about an Indication of Compromise (IOC). It is block type of 150 in series 1. It is used by the host tracker to store information about a compromise on a host. The following diagram shows the structure of an IOC State data block:

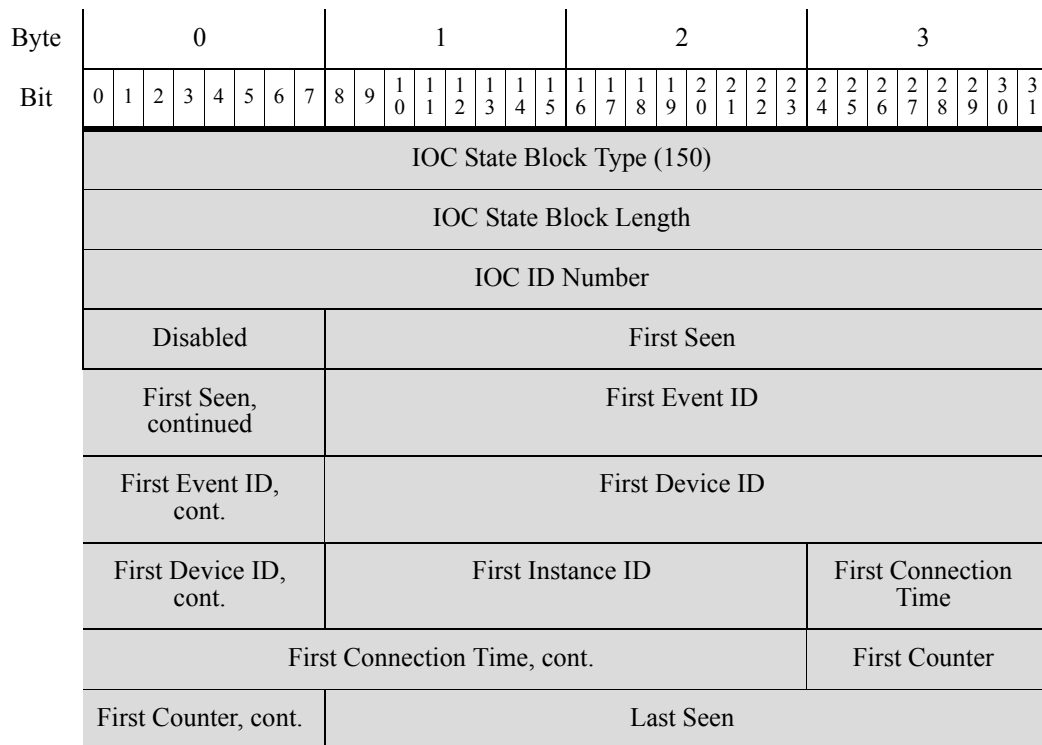

| Byte | 0                           |   |   |   |   |   |   |   | 1                |   |    |    |    |    |    |    | 2            |    |    |    |    |    |    |    | 3                    |    |    |    |    |    |    |    |
|------|-----------------------------|---|---|---|---|---|---|---|------------------|---|----|----|----|----|----|----|--------------|----|----|----|----|----|----|----|----------------------|----|----|----|----|----|----|----|
| Bit  | 0                           | 1 | 2 | 3 | 4 | 5 | 6 | 7 | 8                | 9 | 10 | 11 | 12 | 13 | 14 | 15 | 16           | 17 | 18 | 19 | 20 | 21 | 22 | 23 | 24                   | 25 | 26 | 27 | 28 | 29 | 30 | 31 |
|      | Last Seen, cont.            |   |   |   |   |   |   |   | Last Event ID    |   |    |    |    |    |    |    |              |    |    |    |    |    |    |    |                      |    |    |    |    |    |    |    |
|      | Last Event ID, cont.        |   |   |   |   |   |   |   | Last Device ID   |   |    |    |    |    |    |    |              |    |    |    |    |    |    |    |                      |    |    |    |    |    |    |    |
|      | Last Device ID, cont.       |   |   |   |   |   |   |   | Last Instance ID |   |    |    |    |    |    |    |              |    |    |    |    |    |    |    | Last Connection Time |    |    |    |    |    |    |    |
|      | Last Connection Time, cont. |   |   |   |   |   |   |   |                  |   |    |    |    |    |    |    | Last Counter |    |    |    |    |    |    |    |                      |    |    |    |    |    |    |    |
|      | Last Counter, cont.         |   |   |   |   |   |   |   |                  |   |    |    |    |    |    |    |              |    |    |    |    |    |    |    |                      |    |    |    |    |    |    |    |

The following table describes the components of the IOC State data block.

**Table 4-21** *IOC State Data Block Fields*

| Field                       | Data Type | Description  |
|-----------------------------|-----------|--|
| IOC State Data Block Type   | uint32    | Initiates an IOC State data block. This value is always 150.   |
| IOC State Data Block Length | uint32    | Total number of bytes in the IOC State data block, including eight bytes for the IOC State data block type and length fields, plus the number of bytes of data that follows.                   |
| IOC ID Number               | uint32    | Unique ID number for the compromise.   |
| Disabled                    | uint8     | Indicates whether the compromise has been disabled on the host: <ul style="list-style-type: none"> <li>0 - The compromise is not disabled.</li> <li>1 - The compromise is disabled.</li> </ul> |
| First Seen                  | uint32    | Unix timestamp of when this compromise was first seen.   |
| First Event ID              | uint32    | ID number of the event on which this compromise was first seen.  |
| First Device ID             | uint32    | ID of the sensor which first detected the IOC.   |
| First Instance ID           | uint16    | Numerical ID of the Snort instance on the managed device that first detected the compromise.   |
| First Connection Time       | uint32    | Unix timestamp of the connection where this compromise was first seen.   |
| First Counter               | uint16    | Counter for the connection on which this compromise was last seen. Used to differentiate between multiple connections occurring at the same time.  |
| Last Seen                   | uint32    | Unix timestamp of when this compromise was last seen   |
| Last Event ID               | uint32    | ID number of the event on which this compromise was last seen.   |
| Last Device ID              | uint32    | ID of the sensor which most recently detected the IOC.   |
| Last Instance ID            | uint16    | Numerical ID of the Snort instance on the managed device that last detected the compromise.  |

Table 4-21 IOC State Data Block Fields (continued)

| Field                | Data Type | Description   |
|----------------------|-----------|---|
| Last Connection Time | uint32    | Unix timestamp of the connection on which this compromise was last seen.  |
| Last Counter         | uint16    | Counter for the connection on which this compromise was last seen. Used to differentiate between multiple connections occurring at the same time. |

### IOC Name Data Block for 5.3+

This is a data block that provides the category and event type for an Indication of Compromise (IOC). The record type is 161, with a block type of 39 in series 2. It is exposed as metadata for any event that has IOC information. These include malware events, file events, and intrusion events.

The following diagram shows the structure of an IOC Name data block:

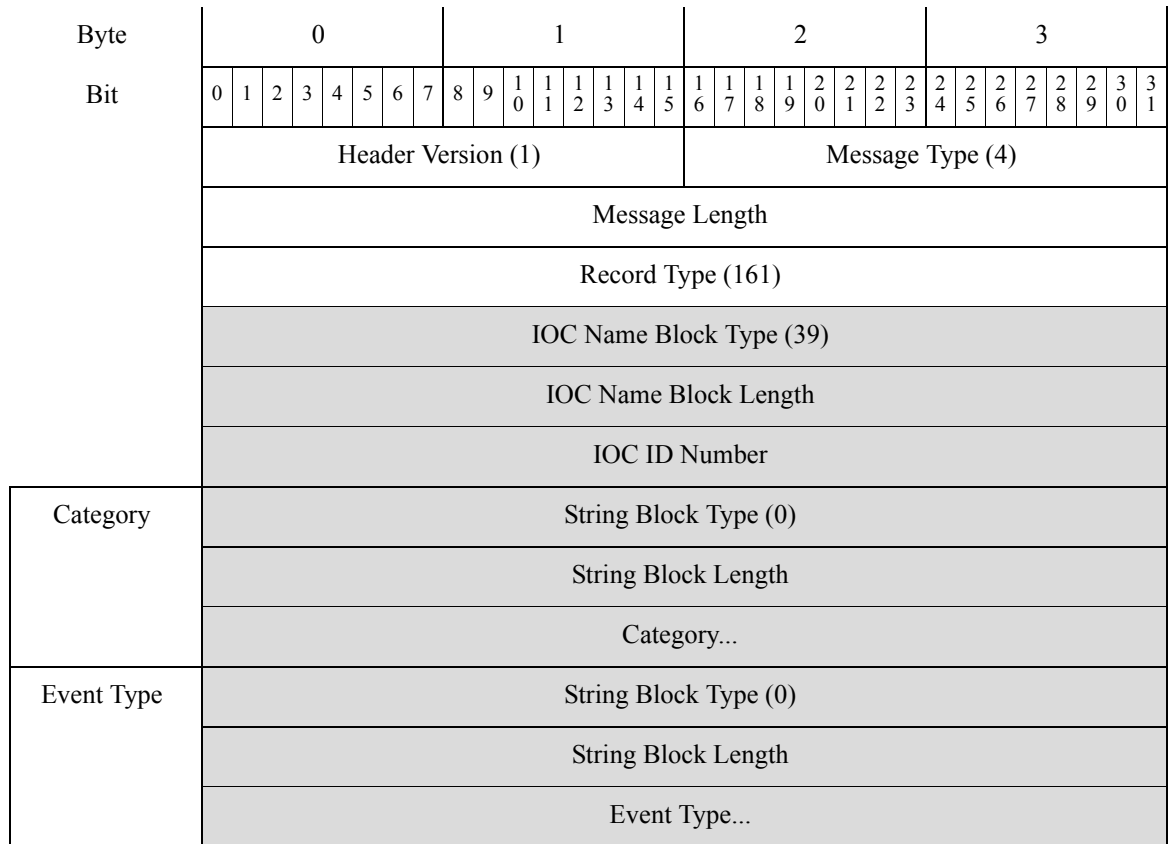

The following table describes the fields in the IOC Name data block.

**Table 4-22** *IOC Name Data Block Fields*

| Field                      | Data Type | Description  |
|----------------------------|-----------|--|
| IOC Name Data Block Type   | uint32    | Initiates an IOC Name data block. This value is always 39.   |
| IOC Name Data Block Length | uint32    | Total number of bytes in the IOC Name data block, including eight bytes for the IOC Name data block type and length fields, plus the number of bytes of data that follows.   |
| IOC ID Number              | uint32    | Unique ID number for the compromise.   |
| String Block Type          | uint32    | Initiates a String data block containing the category associated with the compromise. This value is always 0.  |
| String Block Length        | uint32    | The number of bytes included in the name String data block, including eight bytes for the block type and header fields plus the number of bytes in the Category field.   |
| Category                   | string    | The category for the compromise. Possible values include: <ul style="list-style-type: none"> <li>• CnC Connected</li> <li>• Exploit Kit</li> <li>• High Impact Attack</li> <li>• Low Impact Attack</li> <li>• Malware Detected</li> <li>• Malware Executed</li> <li>• Dropper Infection</li> <li>• Java Compromise</li> <li>• Word Compromise</li> <li>• Adobe Reader Compromise</li> <li>• Excel Compromise</li> <li>• PowerPoint Compromise</li> <li>• QuickTime Compromise</li> </ul> |
| String Block Type          | uint32    | Initiates a String data block containing the event type associated with the compromise. This value is always 0.  |



Table 4-22 IOC Name Data Block Fields (continued)

| Field               | Data Type | Description   |
|---------------------|-----------|---|
| String Block Length | uint32    | The number of bytes included in the name String data block, including eight bytes for the block type and header fields plus the number of bytes in the Event Type field.  |
| Event Type          | string    | The event type for the compromise. Possible values include: <ul style="list-style-type: none"> <li>• Adobe Reader launched shell</li> <li>• Dropper Infection Detected by FireAMP</li> <li>• Excel Compromise Detected by FireAMP</li> <li>• Excel launched shell</li> <li>• Impact 1 Intrusion Event - attempted-admin</li> <li>• Impact 1 Intrusion Event - attempted-user</li> <li>• Impact 1 Intrusion Event - successful-admin</li> <li>• Impact 1 Intrusion Event - successful-user</li> <li>• Impact 1 Intrusion Event - web-application-attack</li> <li>• Impact 2 Intrusion Event - attempted-admin</li> <li>• Impact 2 Intrusion Event - attempted-user</li> <li>• Impact 2 Intrusion Event - successful-admin</li> <li>• Impact 2 Intrusion Event - successful-user</li> <li>• Impact 2 Intrusion Event - web-application-attack</li> <li>• Intrusion Event - exploit-kit</li> <li>• Intrusion Event - malware-backdoor</li> <li>• Intrusion Event - malware-CnC</li> <li>• Java Compromise Detected by FireAMP</li> <li>• Java launched shell</li> <li>• PDF Compromise Detected by FireAMP</li> <li>• PowerPoint Compromise Detected by FireAMP</li> <li>• PowerPoint launched shell</li> <li>• QuickTime Compromise Detected by FireAMP</li> <li>• QuickTime launched shell</li> <li>• Security Intelligence Event - CnC</li> <li>• Suspected Botnet Detected by FireAMP</li> <li>• Threat Detected by FireAMP - Subtype is 'executed'</li> <li>• Threat Detected by FireAMP - Subtype is not 'executed'</li> <li>• Threat Detected in File Transfer - Action is not 'block'</li> <li>• Word Compromise Detected by FireAMP</li> <li>• Word launched shell</li> </ul> |

## Security Intelligence Category Metadata

The eStreamer service transmits metadata containing information about the Security Intelligence category within a Security Intelligence Category record, the format of which is shown below. Access control rule reason metadata is sent when the Version 4 metadata flag—bit 20 in the Request Flags field of a request message—is set. See [Request Flags, page 2-11](#). Note that the Record Type field, which appears after the Message Length field, has a value of 280, indicating a Security Intelligence Category

record. It contains a Security Intelligence Category data block (as documented in [Security Intelligence Category Data Block 5.1+, page 4-175](#)). The Security Intelligence data block is block type 22 in series 2.

| Byte | 0  |   |   |   |   |   |   |   | 1 |   |    |    |    |    |    |    | 2                |    |    |    |    |    |    |    | 3  |    |    |    |    |    |    |    |
|------|--|---|---|---|---|---|---|---|---|---|----|----|----|----|----|----|------------------|----|----|----|----|----|----|----|----|----|----|----|----|----|----|----|
| Bit  | 0  | 1 | 2 | 3 | 4 | 5 | 6 | 7 | 8 | 9 | 10 | 11 | 12 | 13 | 14 | 15 | 16               | 17 | 18 | 19 | 20 | 21 | 22 | 23 | 24 | 25 | 26 | 27 | 28 | 29 | 30 | 31 |
|      | Header Version (1)                             |   |   |   |   |   |   |   |   |   |    |    |    |    |    |    | Message Type (4) |    |    |    |    |    |    |    |    |    |    |    |    |    |    |    |
|      | Message Length                                 |   |   |   |   |   |   |   |   |   |    |    |    |    |    |    |                  |    |    |    |    |    |    |    |    |    |    |    |    |    |    |    |
|      | Record Type (280)                              |   |   |   |   |   |   |   |   |   |    |    |    |    |    |    |                  |    |    |    |    |    |    |    |    |    |    |    |    |    |    |    |
|      | Record Length                                  |   |   |   |   |   |   |   |   |   |    |    |    |    |    |    |                  |    |    |    |    |    |    |    |    |    |    |    |    |    |    |    |
|      | Security Intelligence Category Block Type (22) |   |   |   |   |   |   |   |   |   |    |    |    |    |    |    |                  |    |    |    |    |    |    |    |    |    |    |    |    |    |    |    |
|      | Security Intelligence Category Block Length    |   |   |   |   |   |   |   |   |   |    |    |    |    |    |    |                  |    |    |    |    |    |    |    |    |    |    |    |    |    |    |    |
|      | Security Intelligence List ID                  |   |   |   |   |   |   |   |   |   |    |    |    |    |    |    |                  |    |    |    |    |    |    |    |    |    |    |    |    |    |    |    |
|      | Access Control Policy UUID                     |   |   |   |   |   |   |   |   |   |    |    |    |    |    |    |                  |    |    |    |    |    |    |    |    |    |    |    |    |    |    |    |
|      | Access Control Policy UUID, continued          |   |   |   |   |   |   |   |   |   |    |    |    |    |    |    |                  |    |    |    |    |    |    |    |    |    |    |    |    |    |    |    |
|      | Access Control Policy UUID, continued          |   |   |   |   |   |   |   |   |   |    |    |    |    |    |    |                  |    |    |    |    |    |    |    |    |    |    |    |    |    |    |    |
|      | Access Control Policy UUID, continued          |   |   |   |   |   |   |   |   |   |    |    |    |    |    |    |                  |    |    |    |    |    |    |    |    |    |    |    |    |    |    |    |
|      | String Block Type (0)                          |   |   |   |   |   |   |   |   |   |    |    |    |    |    |    |                  |    |    |    |    |    |    |    |    |    |    |    |    |    |    |    |
|      | String Block Length                            |   |   |   |   |   |   |   |   |   |    |    |    |    |    |    |                  |    |    |    |    |    |    |    |    |    |    |    |    |    |    |    |
|      | Security Intelligence List Name...             |   |   |   |   |   |   |   |   |   |    |    |    |    |    |    |                  |    |    |    |    |    |    |    |    |    |    |    |    |    |    |    |

The following table describes the fields in the Security Intelligence Category record.

**Table 4-23** Security Intelligence Category Metadata Fields

| Field                                       | Data Type | Description  |
|---|-----------|--|
| Security Intelligence Category Block Type   | uint32    | Initiates an Security Intelligence Category data block. This value is always 22. This is a series 2 data block.  |
| Security Intelligence Category Block Length | uint32    | Total number of bytes in the Security Intelligence Category block, including eight bytes for the Security Intelligence Category block type and length fields, plus the number of bytes of data that follows. |
| Security Intelligence List ID               | uint32    | The ID of the IP blacklist or whitelist triggered by the connection.   |
| Access Control Policy UUID                  | uint8[16] | The UUID of the access control policy configured for Security Intelligence.  |

Table 4-23 Security Intelligence Category Metadata Fields (continued)

| Field                           | Data Type | Description   |
|---------------------------------|-----------|---|
| String Block Type               | uint32    | Initiates a String data block containing the descriptive name associated with the access control rule reason. This value is always 0.   |
| String Block Length             | uint32    | The number of bytes included in the name String data block, including eight bytes for the block type and header fields plus the number of bytes in the Security Intelligence List Name field. |
| Security Intelligence List Name | string    | The name of the IP category blacklist or whitelist triggered by the connection.   |

## Security Intelligence Source/Destination Record

The eStreamer service transmits metadata containing whether a Security Intelligence-detected IP address is a source IP address or destination IP address within a Security Intelligence Source/Destination record, the format of which is shown below. (The source/destination IP information is sent when one of the metadata flags—bits 1, 14, 15, or 20 in the Request Flags field of a request message—is set. See [Request Flags, page 2-11](#).) Note that the Record Type field, which appears after the Message Length field, has a value of 281, indicating a Security Intelligence Source/Destination record.

| Byte | 0   |   |   |   |   |   |   |   | 1 |   |    |    |    |    |    |    | 2                |    |    |    |    |    |    |    | 3  |    |    |    |    |    |    |    |
|------|---|---|---|---|---|---|---|---|---|---|----|----|----|----|----|----|------------------|----|----|----|----|----|----|----|----|----|----|----|----|----|----|----|
| Bit  | 0   | 1 | 2 | 3 | 4 | 5 | 6 | 7 | 8 | 9 | 10 | 11 | 12 | 13 | 14 | 15 | 16               | 17 | 18 | 19 | 20 | 21 | 22 | 23 | 24 | 25 | 26 | 27 | 28 | 29 | 30 | 31 |
|      | Header Version (1)                              |   |   |   |   |   |   |   |   |   |    |    |    |    |    |    | Message Type (4) |    |    |    |    |    |    |    |    |    |    |    |    |    |    |    |
|      | Message Length                                  |   |   |   |   |   |   |   |   |   |    |    |    |    |    |    |                  |    |    |    |    |    |    |    |    |    |    |    |    |    |    |    |
|      | Record Type (281)                               |   |   |   |   |   |   |   |   |   |    |    |    |    |    |    |                  |    |    |    |    |    |    |    |    |    |    |    |    |    |    |    |
|      | Record Length                                   |   |   |   |   |   |   |   |   |   |    |    |    |    |    |    |                  |    |    |    |    |    |    |    |    |    |    |    |    |    |    |    |
|      | Security Intelligence Source/Destination ID     |   |   |   |   |   |   |   |   |   |    |    |    |    |    |    |                  |    |    |    |    |    |    |    |    |    |    |    |    |    |    |    |
|      | Security Intelligence Source/Destination Length |   |   |   |   |   |   |   |   |   |    |    |    |    |    |    |                  |    |    |    |    |    |    |    |    |    |    |    |    |    |    |    |
|      | Security Intelligence Source/Destination...     |   |   |   |   |   |   |   |   |   |    |    |    |    |    |    |                  |    |    |    |    |    |    |    |    |    |    |    |    |    |    |    |

The following table describes the fields in the Security Intelligence Source/Destination record.

**Table 4-24** Security Intelligence Source/Destination Record Fields

| Field  | Data Type | Description   |
|--|-----------|---|
| Security Intelligence Source/ Destination ID     | uint32    | The Security Intelligence source/destination ID number.                       |
| Security Intelligence Source/ Destination Length | uint32    | The number of bytes included in the Security Intelligence source/destination. |
| Security Intelligence Source/ Destination        | string    | Whether the detected IP address is a source or destination IP address.        |

## Discovery Event Header 5.2+

Discovery and connection event messages contain a discovery event header. It conveys the type and subtype of the event, the time the event occurred, the device on which the event occurred, and the structure of the event data in the message. This header is followed by the actual host discovery, user, or connection event data. The structures associated with the different event type/subtype values are described in [Host Discovery Structures by Event Type, page 4-37](#). This header has IPv6 support, and deprecates [Discovery Event Header 5.0 - 5.1.1.x, page B-55](#).

The event type and event subtype fields of the discovery event header identify the structure of the transmitted event message. After the structure of the event data block is determined, your program can parse the message appropriately.

The shaded rows in the following diagram illustrate the format of the discovery event header.

| Byte | 0   |   |   |   |   |   |   |   | 1 |   |    |    |    |    |    |    | 2                |    |    |    |    |    |    |    | 3  |    |    |    |    |    |    |    |
|------|---|---|---|---|---|---|---|---|---|---|----|----|----|----|----|----|------------------|----|----|----|----|----|----|----|----|----|----|----|----|----|----|----|
| Bit  | 0   | 1 | 2 | 3 | 4 | 5 | 6 | 7 | 8 | 9 | 10 | 11 | 12 | 13 | 14 | 15 | 16               | 17 | 18 | 19 | 20 | 21 | 22 | 23 | 24 | 25 | 26 | 27 | 28 | 29 | 30 | 31 |
|      | Header Version (1)  |   |   |   |   |   |   |   |   |   |    |    |    |    |    |    | Message Type (4) |    |    |    |    |    |    |    |    |    |    |    |    |    |    |    |
|      | Message Length  |   |   |   |   |   |   |   |   |   |    |    |    |    |    |    |                  |    |    |    |    |    |    |    |    |    |    |    |    |    |    |    |
|      | Record Type   |   |   |   |   |   |   |   |   |   |    |    |    |    |    |    |                  |    |    |    |    |    |    |    |    |    |    |    |    |    |    |    |
|      | Record Length   |   |   |   |   |   |   |   |   |   |    |    |    |    |    |    |                  |    |    |    |    |    |    |    |    |    |    |    |    |    |    |    |
|      | eStreamer Server Timestamp (in events, only if bit 23 is set) |   |   |   |   |   |   |   |   |   |    |    |    |    |    |    |                  |    |    |    |    |    |    |    |    |    |    |    |    |    |    |    |
|      | Reserved for Future Use (in events, only if bit 23 is set)    |   |   |   |   |   |   |   |   |   |    |    |    |    |    |    |                  |    |    |    |    |    |    |    |    |    |    |    |    |    |    |    |

| Byte                    | 0                                 |   |   |   |   |   |   |   | 1 |   |    |    |    |    |    |    | 2        |    |    |    |    |    |    |    | 3                       |    |    |    |    |    |    |    |
|-------------------------|-----------------------------------|---|---|---|---|---|---|---|---|---|----|----|----|----|----|----|----------|----|----|----|----|----|----|----|-------------------------|----|----|----|----|----|----|----|
| Bit                     | 0                                 | 1 | 2 | 3 | 4 | 5 | 6 | 7 | 8 | 9 | 10 | 11 | 12 | 13 | 14 | 15 | 16       | 17 | 18 | 19 | 20 | 21 | 22 | 23 | 24                      | 25 | 26 | 27 | 28 | 29 | 30 | 31 |
| Discovery Event Header  | Device ID                         |   |   |   |   |   |   |   |   |   |    |    |    |    |    |    |          |    |    |    |    |    |    |    |                         |    |    |    |    |    |    |    |
|                         | Legacy IP Address                 |   |   |   |   |   |   |   |   |   |    |    |    |    |    |    |          |    |    |    |    |    |    |    |                         |    |    |    |    |    |    |    |
|                         | MAC Address                       |   |   |   |   |   |   |   |   |   |    |    |    |    |    |    |          |    |    |    |    |    |    |    |                         |    |    |    |    |    |    |    |
|                         | MAC Address, continued            |   |   |   |   |   |   |   |   |   |    |    |    |    |    |    | Has IPv6 |    |    |    |    |    |    |    | Reserved for future use |    |    |    |    |    |    |    |
|                         | Event Second                      |   |   |   |   |   |   |   |   |   |    |    |    |    |    |    |          |    |    |    |    |    |    |    |                         |    |    |    |    |    |    |    |
|                         | Event Microsecond                 |   |   |   |   |   |   |   |   |   |    |    |    |    |    |    |          |    |    |    |    |    |    |    |                         |    |    |    |    |    |    |    |
|                         | Event Type                        |   |   |   |   |   |   |   |   |   |    |    |    |    |    |    |          |    |    |    |    |    |    |    |                         |    |    |    |    |    |    |    |
|                         | Event Subtype                     |   |   |   |   |   |   |   |   |   |    |    |    |    |    |    |          |    |    |    |    |    |    |    |                         |    |    |    |    |    |    |    |
|                         | File Number (Internal Use Only)   |   |   |   |   |   |   |   |   |   |    |    |    |    |    |    |          |    |    |    |    |    |    |    |                         |    |    |    |    |    |    |    |
|                         | File Position (Internal Use Only) |   |   |   |   |   |   |   |   |   |    |    |    |    |    |    |          |    |    |    |    |    |    |    |                         |    |    |    |    |    |    |    |
|                         | IPv6 Address                      |   |   |   |   |   |   |   |   |   |    |    |    |    |    |    |          |    |    |    |    |    |    |    |                         |    |    |    |    |    |    |    |
|                         | IPv6 Address, continued           |   |   |   |   |   |   |   |   |   |    |    |    |    |    |    |          |    |    |    |    |    |    |    |                         |    |    |    |    |    |    |    |
| IPv6 Address, continued |                                   |   |   |   |   |   |   |   |   |   |    |    |    |    |    |    |          |    |    |    |    |    |    |    |                         |    |    |    |    |    |    |    |
| IPv6 Address, continued |                                   |   |   |   |   |   |   |   |   |   |    |    |    |    |    |    |          |    |    |    |    |    |    |    |                         |    |    |    |    |    |    |    |

The following table describes the discovery event header.

**Table 4-25** Discovery Event Header Fields

| Field                   | Data Types | Description  |
|-------------------------|------------|--|
| Device ID               | uint32     | ID number of the device that generated the discovery event. You can obtain the metadata for the device by requesting Version 3 and 4 metadata. See <a href="#">Managed Device Record Metadata, page 3-30</a> for more information. |
| Legacy IP Address       | uint32     | This field is reserved but no longer populated. The IPv4 address is stored in the IPv6 Address field. See <a href="#">IP Addresses, page 1-5</a> for more information.   |
| MAC Address             | uint8[6]   | MAC address of the host involved in the event.   |
| Has IPv6                | uint8      | Flag indicating that the host has an IPv6 address.   |
| Reserved for future use | uint8      | Reserved for future use  |

Table 4-25 Discovery Event Header Fields (continued)

| Field             | Data Types | Description   |
|-------------------|------------|---|
| Event Second      | uint32     | UNIX timestamp (seconds since 01/01/1970) that the system generated the event.  |
| Event Microsecond | uint32     | Microsecond (one millionth of a second) increment that the system generated the event.  |
| Event Type        | uint32     | Event type (1000 for new events, 1001 for change events, 1002 for user input events, 1050 for full host profile). See <a href="#">Host Discovery Structures by Event Type, page 4-37</a> for a list of available event types. |
| Event Subtype     | uint32     | Event subtype. See <a href="#">Host Discovery Structures by Event Type, page 4-37</a> for a list of available event subtypes.   |
| File Number       | byte[4]    | Serial file number. This field is for Cisco internal use and can be disregarded.  |
| File Position     | byte[4]    | Event's position in the serial file. This field is for Cisco internal use and can be disregarded.   |
| IPv6 Address      | uin8[16]   | IPv6 address. This field is present and used if the Has IPv6 flag is set.   |

## Discovery and Connection Event Types and Subtypes

The values in the Event Type and Event Subtype fields identify and classify the event contained in a host discovery or user data message. They also identify the structure of the data in the message.

The following table lists the event types and event subtypes for discovery and connection events.

Table 4-26 Discovery and Connection Events by Type and Subtype

| Event Name               | Event Type | Event Subtype |
|--------------------------|------------|---------------|
| New Host                 | 1000       | 1             |
| New TCP Server           | 1000       | 2             |
| New Network Protocol     | 1000       | 3             |
| New Transport Protocol   | 1000       | 4             |
| New IP to IP Traffic     | 1000       | 5             |
| New UDP Server           | 1000       | 6             |
| New Client Application   | 1000       | 7             |
| New OS                   | 1000       | 8             |
| New IPv6 to IPv6 Traffic | 1000       | 9             |
| Host IP Address Changed  | 1001       | 1             |
| OS Information Update    | 1001       | 2             |
| Host IP Address Reused   | 1001       | 3             |
| Vulnerability Change     | 1001       | 4             |

Table 4-26 Discovery and Connection Events by Type and Subtype (continued)

| Event Name                                | Event Type | Event Subtype |
|---|------------|---------------|
| Hops Change                               | 1001       | 5             |
| TCP Server Information Update             | 1001       | 6             |
| Host Timeout                              | 1001       | 7             |
| TCP Port Closed                           | 1001       | 8             |
| UDP Port Closed                           | 1001       | 9             |
| UDP Server Information Update             | 1001       | 10            |
| TCP Port Timeout                          | 1001       | 11            |
| UDP Port Timeout                          | 1001       | 12            |
| MAC Information Change                    | 1001       | 13            |
| Additional MAC Detected for Host          | 1001       | 14            |
| Host Last Seen                            | 1001       | 15            |
| Host Identified as Router/Bridge          | 1001       | 16            |
| Connection Statistics                     | 1001       | 17            |
| VLAN Tag Information Update               | 1001       | 18            |
| Host Deleted: Host Limit Reached          | 1001       | 19            |
| Client Application Timeout                | 1001       | 20            |
| NetBIOS Name Change                       | 1001       | 21            |
| NetBIOS Domain Change                     | 1001       | 22            |
| Host Dropped: Host Limit Reached          | 1001       | 23            |
| Banner Update                             | 1001       | 24            |
| TCP Server Confidence Update              | 1001       | 25            |
| UDP Server Confidence Update              | 1001       | 26            |
| Identity Conflict                         | 1001       | 29            |
| Identity Timeout                          | 1001       | 30            |
| Secondary Host Update                     | 1001       | 31            |
| Client Application Update                 | 1001       | 32            |
| User Set Valid Vulnerabilities (Legacy)   | 1002       | 1             |
| User Set Invalid Vulnerabilities (Legacy) | 1002       | 2             |
| User Delete Address (Legacy)              | 1002       | 3             |
| User Delete Server (Legacy)               | 1002       | 4             |
| User Set Host Criticality                 | 1002       | 5             |
| Host Attribute Add                        | 1002       | 6             |
| Host Attribute Update                     | 1002       | 7             |
| Host Attribute Delete                     | 1002       | 8             |
| Host Attribute Set Value (Legacy)         | 1002       | 9             |
| Host Attribute Delete Value (Legacy)      | 1002       | 10            |

**Table 4-26** *Discovery and Connection Events by Type and Subtype (continued)*

| Event Name                                 | Event Type | Event Subtype |
|--|------------|---------------|
| Add Scan Result                            | 1002       | 11            |
| User Set Vulnerability Qualification       | 1002       | 12            |
| User Policy Control                        | 1002       | 13            |
| Delete Protocol                            | 1002       | 14            |
| Delete Client Application                  | 1002       | 15            |
| User Set Operating System                  | 1002       | 16            |
| User Account Seen                          | 1002       | 17            |
| User Account Update                        | 1002       | 18            |
| User Set Server                            | 1002       | 19            |
| User Delete Address (Current)              | 1002       | 20            |
| User Delete Server (Current)               | 1002       | 21            |
| User Set Valid Vulnerabilities (Current)   | 1002       | 22            |
| User Set Invalid Vulnerabilities (Current) | 1002       | 23            |
| User Host Criticality                      | 1002       | 24            |
| Host Attribute Set Value (Current)         | 1002       | 25            |
| Host Attribute Delete Value (Current)      | 1002       | 26            |
| User Add Host                              | 1002       | 27            |
| User Add Server                            | 1002       | 28            |
| User Add Client Application                | 1002       | 29            |
| User Add Protocol                          | 1002       | 30            |
| Reload App                                 | 1002       | 31            |
| Account Delete                             | 1002       | 32            |
| Connection Statistics                      | 1003       | 1             |
| Connection Chunks                          | 1003       | 2             |
| New User Identity                          | 1004       | 1             |
| User Login                                 | 1004       | 2             |
| Delete User Identity                       | 1004       | 3             |
| User Identity Dropped: User Limit Reached  | 1004       | 4             |
| Host IOC Set Type                          | 1008       | 1             |
| Full Host Profile                          | 1050       | N/A           |

**Tip**

For information about the data structure used for each event type/subtype, see [Host Discovery Structures by Event Type](#), page 4-37.



## Host Discovery Structures by Event Type

eStreamer builds host discovery event messages based on the event type indicated in the discovery event header. The following sub-sections describe the high-level structure for each event type:

- [New Host and Host Last Seen Messages, page 4-38](#)
- [Server Messages, page 4-38](#)
- [New Network Protocol Message, page 4-39](#)
- [New Transport Protocol Message, page 4-39](#)
- [Client Application Messages, page 4-40](#)
- [IP Address Change Message, page 4-40](#)
- [Operating System Update Messages, page 4-41](#)
- [IP Address Reused and Host Timeout/Deleted Messages, page 4-42](#)
- [Vulnerability Change Message, page 4-42](#)
- [Hops Change Message, page 4-43](#)
- [TCP and UDP Port Closed/Timeout Messages, page 4-43](#)
- [MAC Address Messages, page 4-43](#)
- [Host Identified as a Bridge/Router Message, page 4-44](#)
- [VLAN Tag Information Update Messages, page 4-44](#)
- [Change NetBIOS Name Message, page 4-45](#)
- [Update Banner Message, page 4-45](#)
- [Policy Control Message, page 4-46](#)
- [Connection Statistics Data Message, page 4-46](#)
- [Connection Chunk Message, page 4-47](#)
- [User Set Vulnerabilities Messages for Version 4.6.1+, page 4-47](#)
- [User Add and Delete Host Messages, page 4-48](#)
- [User Delete Server Message, page 4-49](#)
- [User Set Host Criticality Messages, page 4-49](#)
- [Attribute Messages, page 4-50](#)
- [Attribute Value Messages, page 4-50](#)
- [User Server and Operating System Messages, page 4-51](#)
- [User Protocol Messages, page 4-51](#)
- [User Client Application Messages, page 4-52](#)
- [Add Scan Result Messages, page 4-52](#)
- [New Operating System Messages, page 4-53](#)
- [Identity Conflict and Identity Timeout System Messages, page 4-53](#)

The data block diagrams in the following sections depict the different record data blocks returned in host discovery event messages.

## New Host and Host Last Seen Messages

New Host and Host Last Seen event messages have a standard discovery event header and a Host Profile data block (as documented in [Host Profile Data Block for 5.2+, page 4-144](#)). The Host Profile data block is block type 139 in series 1.

Note that the Host Last Seen message includes server information only for servers on the host that have changed within the Update Interval set in the discovery detection policy. In other words, only servers that have changed since the system last reported information will be included in the Host Last Seen message.



### Note

The Host Profile data block differs depending on which system version created the message. For information on legacy versions of the Host Profile data block, see [Legacy Host Data Structures, page B-131](#).

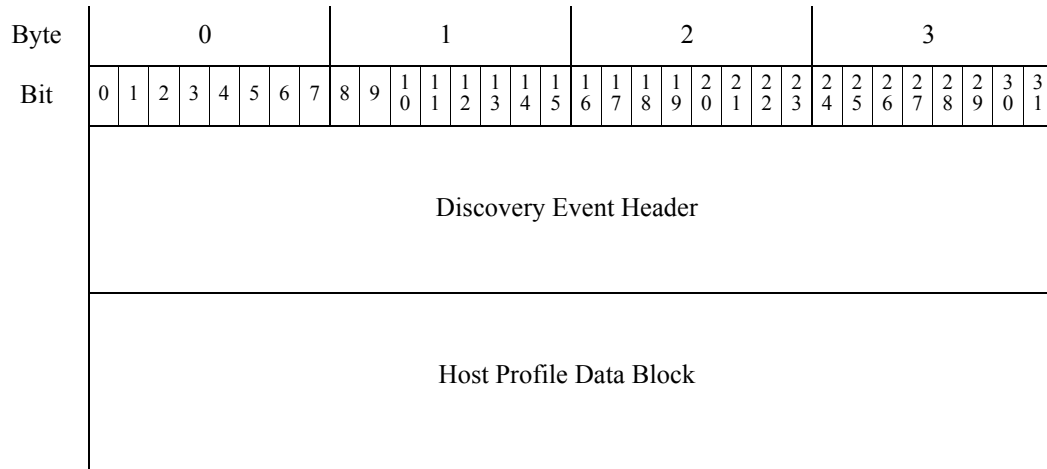

## Server Messages

The following TCP and UDP server event messages have a standard discovery event header (as documented in [Discovery Event Header 5.2+, page 4-32](#)) followed by a Server data block (as documented in [Host Server Data Block 4.10.0+, page 4-120](#), block type 103 in series 1):

- New TCP Server
- New UDP Server
- TCP Server Information Update
- UDP Server Information Update
- TCP Server Confidence Update
- UDP Server Confidence Update



### Note

The Server data block differs depending on which system version created the message. For information on the legacy versions of the Server data block, see [Understanding Legacy Data Structures, page B-1](#).

Each of these events uses the following format:

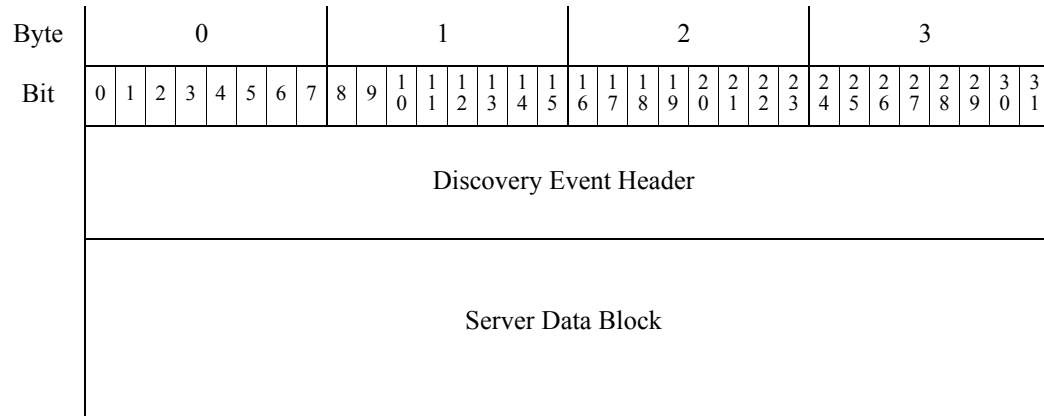

### New Network Protocol Message

A New Network Protocol event message has a standard discovery event header (as documented in [Discovery Event Header 5.2+, page 4-32](#)) followed by a two-byte field for the network protocol (using protocol values described in following table).

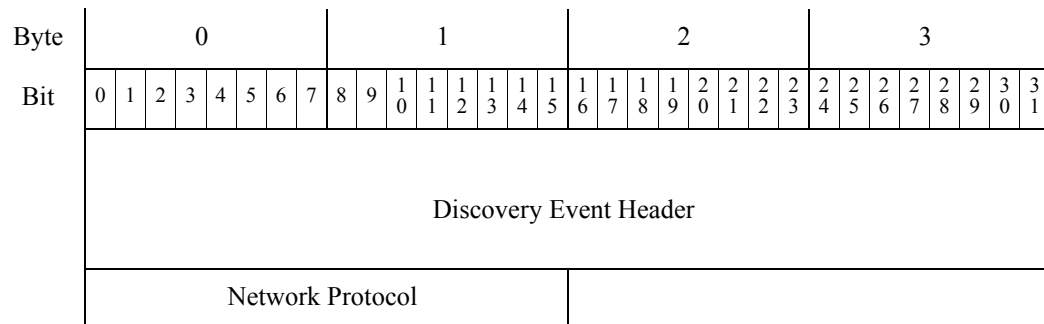

### New Transport Protocol Message

A New Transport Protocol event message has a standard discovery event header (as documented in [Discovery Event Header 5.2+, page 4-32](#), block type 4 in series 1) and a one-byte field for the transport protocol number (using values described in following table).

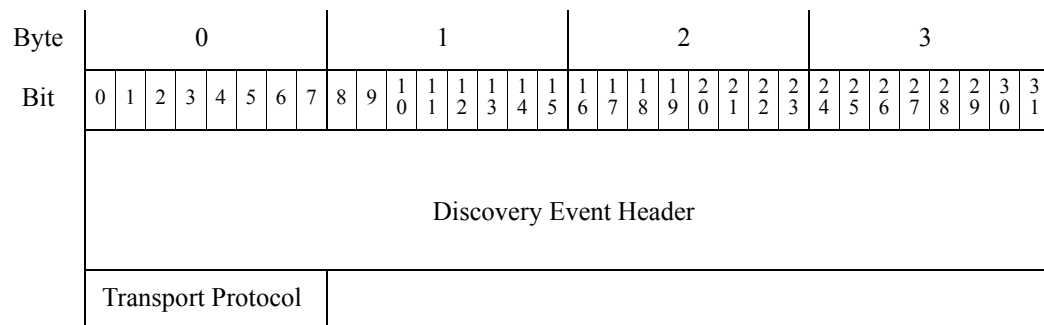

## Client Application Messages

New Client Application, Client Application Update, and Client Application Timeout events have the same format and contain a standard discovery event header (as documented in [Discovery Event Header 5.2+, page 4-32](#)) followed by a Client Application data block (see [Host Client Application Data Block for 5.0+, page 4-137](#), block type 122 in series 1). The discovery event header has a different record type, event type, and event subtype, depending on the event transmitted.



### Note

The Client Application data block differs depending on the system version that created the message. For information on the legacy version of the Client Application data block, see [Understanding Legacy Data Structures, page B-1](#).

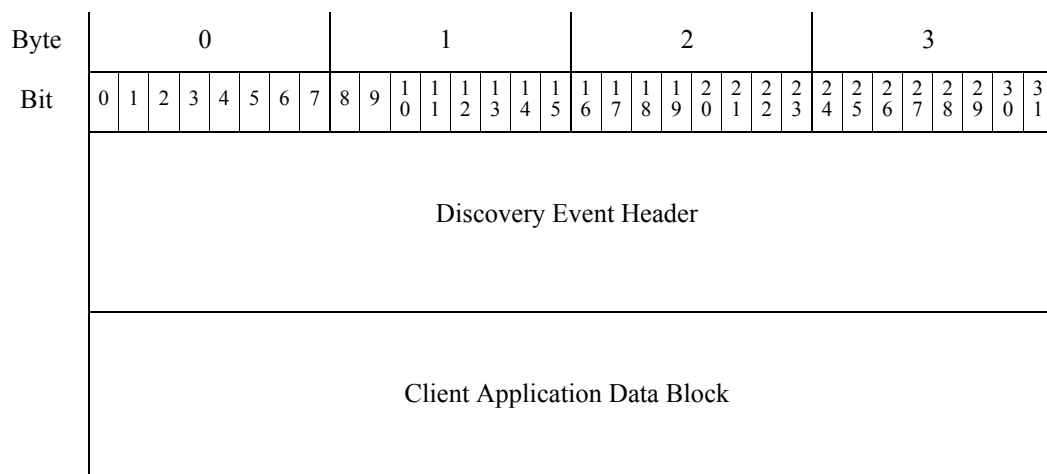

## IP Address Change Message

The following host discovery messages have a standard discovery event header (as documented in [Discovery Event Header 5.2+, page 4-32](#)) and two different forms, structures, one with four bytes for the IP address and one with 16 bytes for the IP address.

Four bytes are used for the IP address (in IP address octets) in the following case:

- New IPv4 to IPv4 Traffic
- Host IP Address Changed, when the RNA event version is less than 10

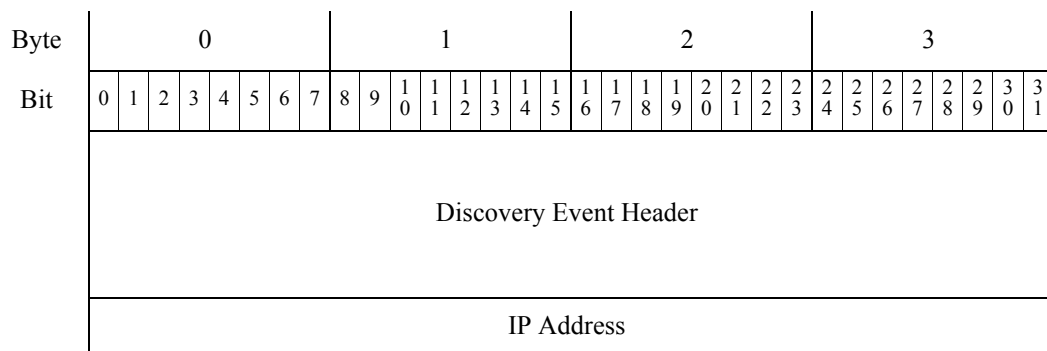

16 bytes are used for the IP address in the following cases:

- New IPv6 to IPv6 Traffic
- Host IP Address Changed, when the RNA event version is 10

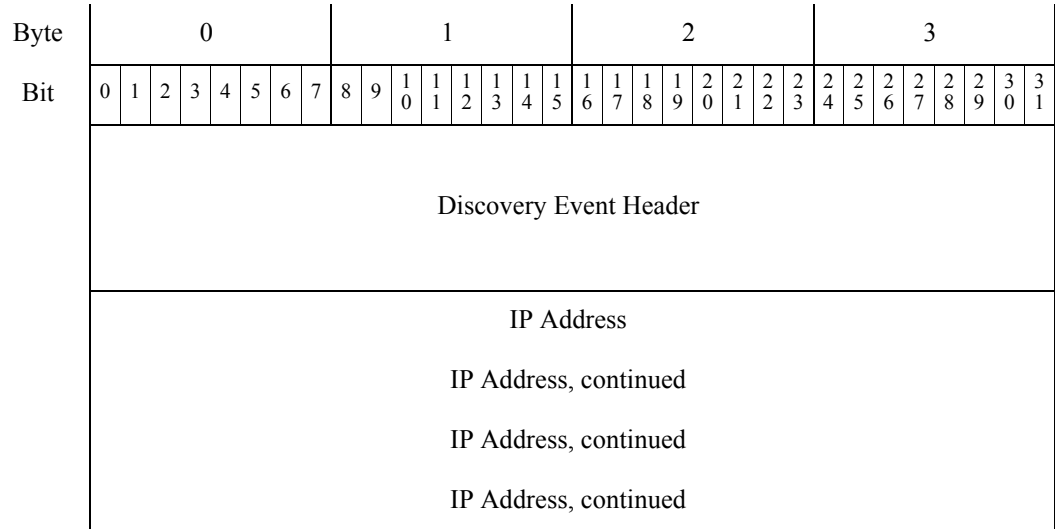

### Operating System Update Messages

The OS Information Update event message has a standard discovery event header (as documented in [Discovery Event Header 5.2+](#), page 4-32) followed by an Operating System data block (as documented in [Operating System Data Block 3.5+](#), page 4-79, block type 53 in series 1).

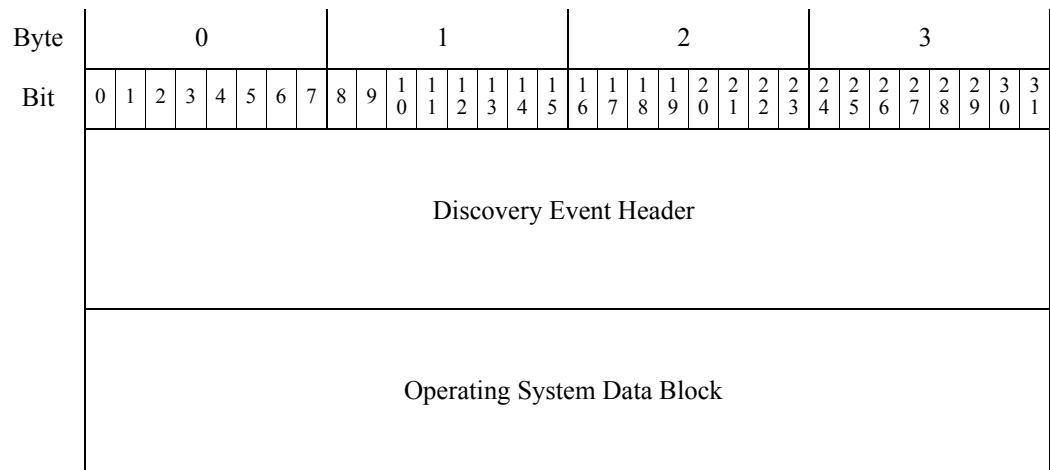

## IP Address Reused and Host Timeout/Deleted Messages

The following host event messages have a standard discovery event header (as documented in [Discovery Event Header 5.2+](#), page 4-32) with no other data:

- Host IP Address Reused
- Host Timeout
- Host Deleted: Host Limit Reached
- Host Dropped: Host Limit Reached

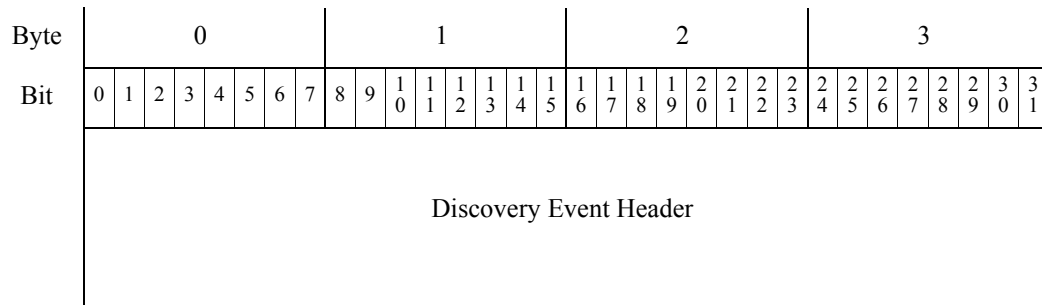

## Vulnerability Change Message

A Vulnerability Change event message has a standard discovery event header (as documented in [Discovery Event Header 5.2+](#), page 4-32) followed by a Vulnerability Reference data block (as documented in [Vulnerability Reference Data Block](#), page 4-69, block type 8 in series 1).

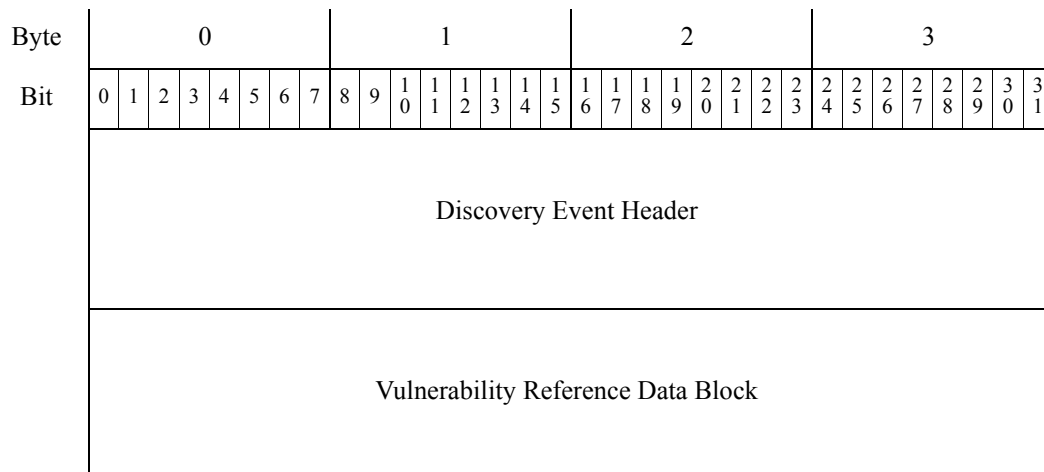

## Hops Change Message

A Hops Change event message has a standard discovery event header (as documented in [Discovery Event Header 5.2+](#), [page 4-32](#)) followed by a one-byte field for the hops count.

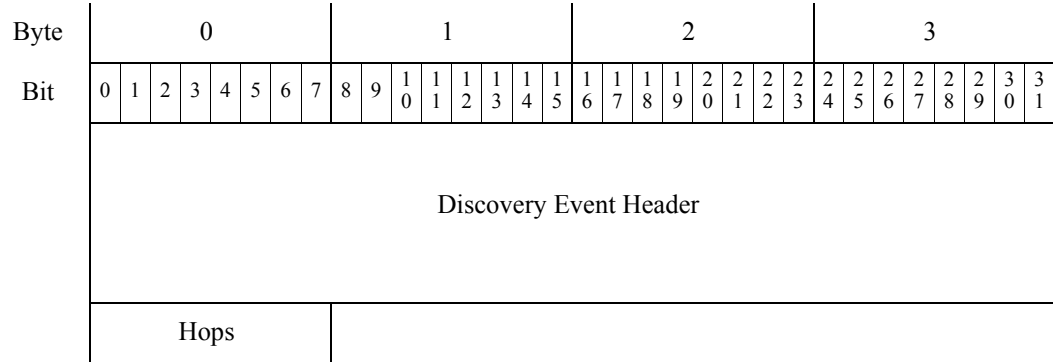

## TCP and UDP Port Closed/Timeout Messages

TCP and UDP Port Closed and Port Timeout event messages have a standard discovery event header (as documented in [Discovery Event Header 5.2+](#), [page 4-32](#)) followed by a two-byte field for the port number.

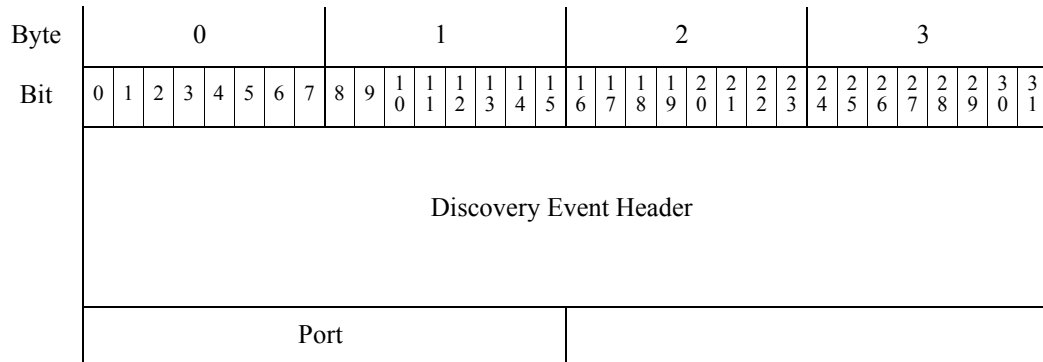

## MAC Address Messages

MAC Information Change and Additional MAC Detected for Host messages have a standard discovery event header (as documented in [Discovery Event Header 5.2+](#), [page 4-32](#)), 1 byte for the TTL value, 6 bytes for the MAC address, and 1 byte to indicate whether the MAC address was detected via ARP/DHCP traffic as the actual MAC address.



### Note

If you receive MAC address messages from a system running version 4.9.x, you must check for the length of the MAC address data block and decode accordingly. If the data block is 8 bytes in length (16 bytes with the header), see [MAC Address Messages, page 4-43](#). If the data block is 12 bytes in length (20 bytes with the header), see [Host MAC Address 4.9+, page 4-108](#).

Note that the MAC address data block header is **not** used within MAC Information Change and Additional MAC Detected for Host messages.

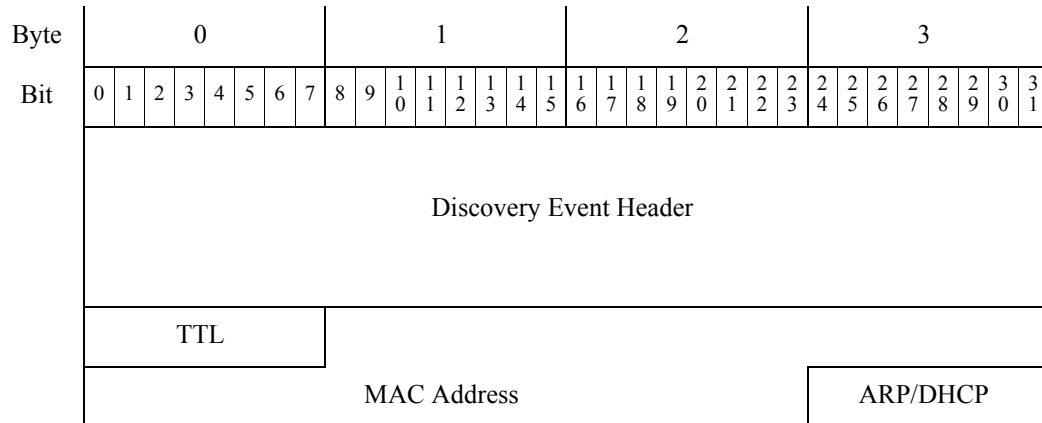

## Host Identified as a Bridge/Router Message

A Host Identified as a Bridge/Router event message has a standard discovery event header (as documented in [Discovery Event Header 5.2+, page 4-32](#)) followed by a four-byte field for the value that matches the host type:

- 0 - host
- 1 - router
- 2 - bridge

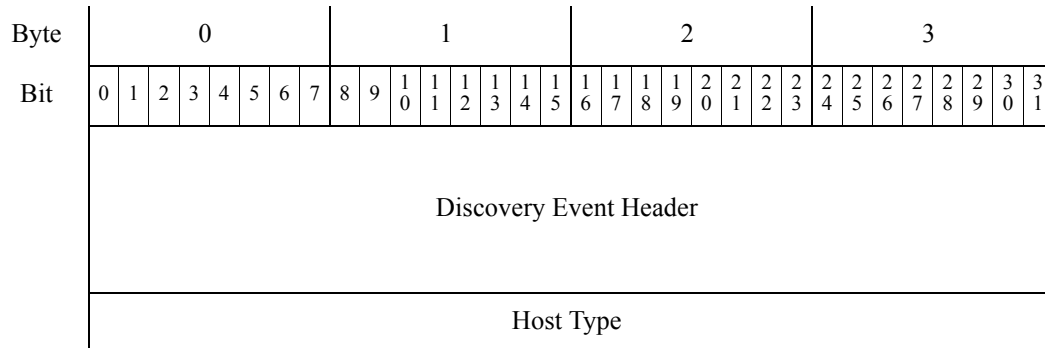

## VLAN Tag Information Update Messages

The VLAN Tag Information Update event has a standard discovery event header (as documented in [Discovery Event Header 5.2+, page 4-32](#)) followed by VLAN data block (as documented in [VLAN Data Block, page 4-71](#)). The VLAN Data block is block type 14 in the series 1 group of blocks.



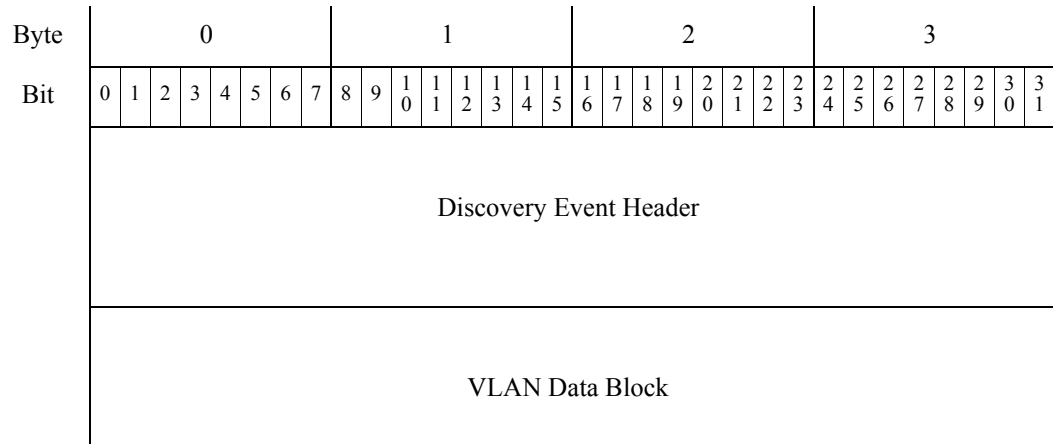

## Change NetBIOS Name Message

A Change NetBIOS Name event message has a standard discovery event header (as documented in [Discovery Event Header 5.2+, page 4-32](#)) followed by a String Information data block (as documented in [String Information Data Block, page 4-73](#)). The String Information data block is block type 35 in series 1.



Note

The Change NetBIOS Domain event is not currently generated by the FireSIGHT System.

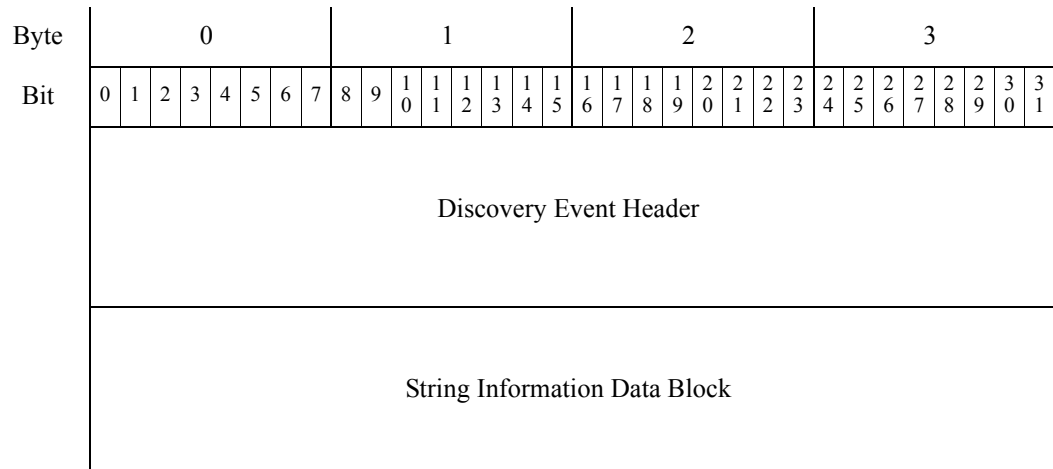

## Update Banner Message

An Update Banner event message has a standard discovery event header (as documented in [Discovery Event Header 5.2+, page 4-32](#)) followed by a Server Banner data block (as documented in [Server Banner Data Block, page 4-72](#)). The server banner data block is block type 37 in series 1.

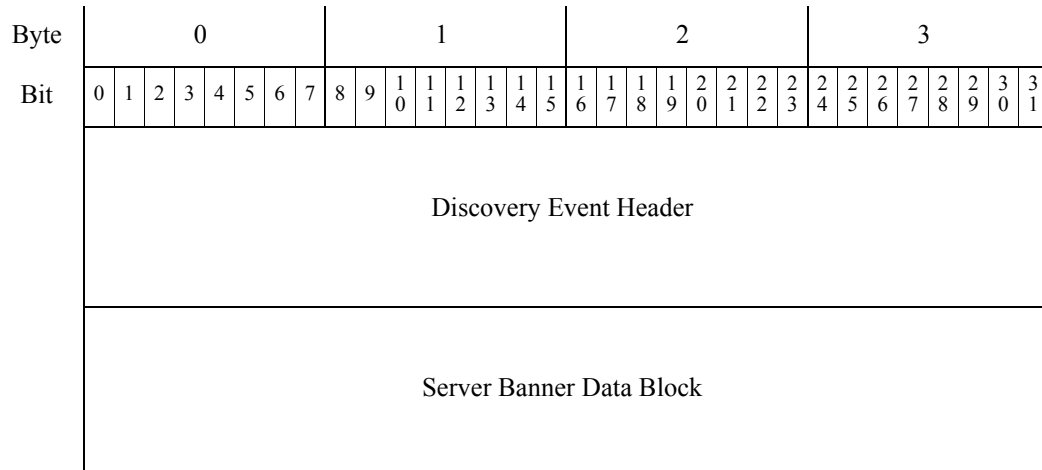

## Policy Control Message

The Policy Control Message event has a standard discovery event header (as documented in [Discovery Event Header 5.2+, page 4-32](#)) followed by a Policy Control Message data block. The format of the Policy Control Message data block differs depending on the system version. For information on policy control message data block format for the current version, see [Policy Engine Control Message Data Block, page 4-79](#).

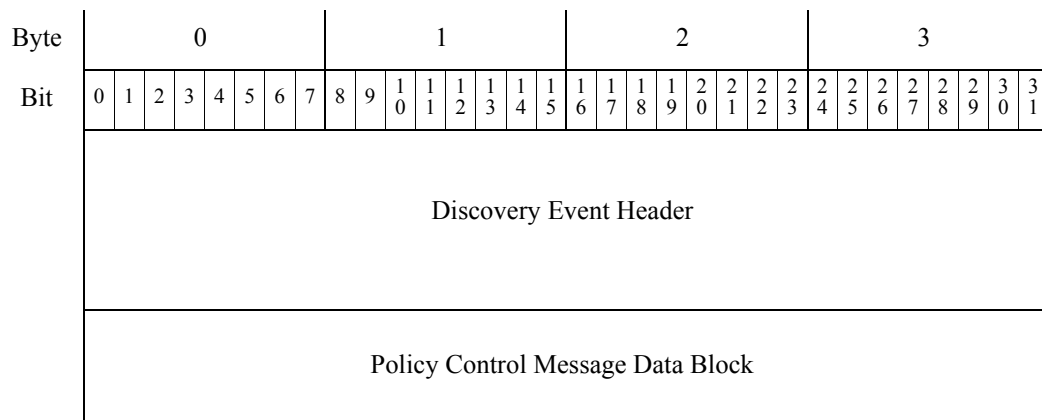

## Connection Statistics Data Message

The Connection Statistics event has a standard discovery event header (as documented in [Discovery Event Header 5.2+, page 4-32](#)) followed by a Connection Statistics data block. The documentation of each version of the Connection Statistics data block includes the system versions that use it. For information on the connection statistics data block format for version 5.3.1+, see [Connection Statistics Data Block 5.3.1+, page 4-111](#).



### Note

The Connection Statistics data block differs depending on which system version created the message. For information on legacy versions, see the Connection Statistics data block in [Understanding Legacy Data Structures, page B-1](#).

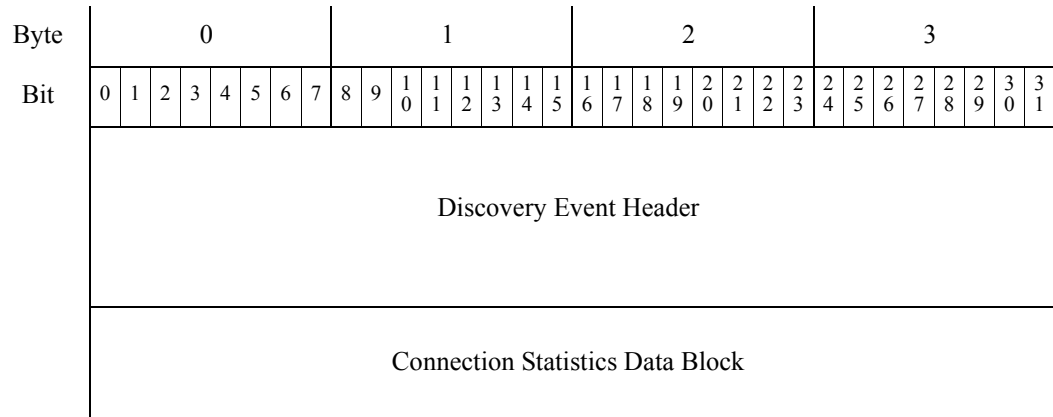

## Connection Chunk Message

The Connection Chunk event has a standard discovery event header (as documented in [Discovery Event Header 5.2+, page 4-32](#)) followed by a Connection Chunk data block. The format differs depending on the system version. For information on connection chunk data block format for the current version, see [Connection Chunk Data Block for 5.1.1+, page 4-93](#). The Connection Chunk data block is block type 136 in series 1.

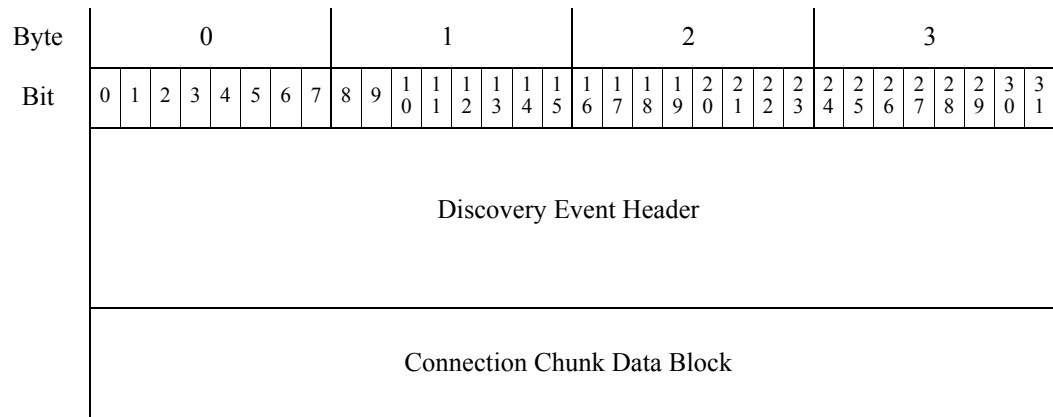

## User Set Vulnerabilities Messages for Version 4.6.1+

User Set Valid Vulnerabilities, User Set Invalid Vulnerabilities, and User Vulnerability Qualification messages use the same data format: the standard discovery event header (see [Discovery Event Header 5.2+, page 4-32](#)) followed by a User Vulnerability change data block (see [User Vulnerability Change Data Block 4.7+, page 4-99](#), block type 80 in series 1). They are differentiated by record type, event type, and event subtype.

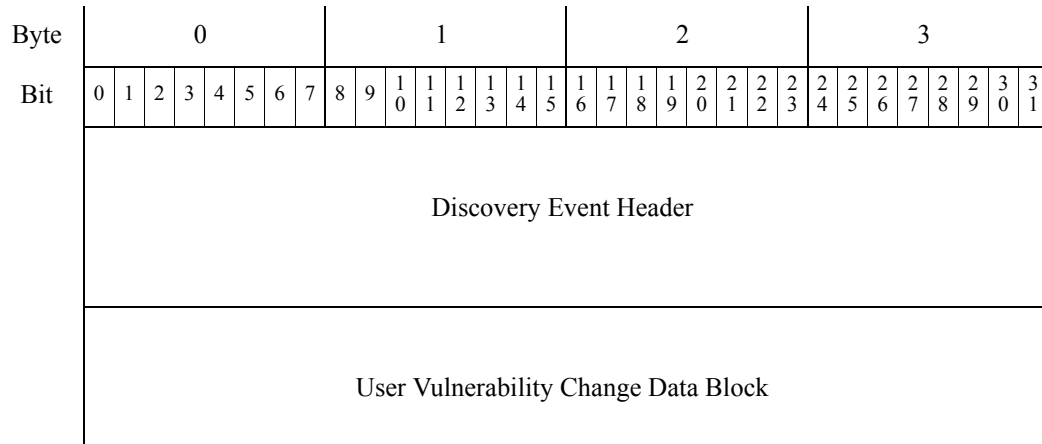

## User Add and Delete Host Messages

The following host input event messages have the standard discovery event header (see [Discovery Event Header 5.2+](#), page 4-32) followed by a User Hosts data block (see [User Hosts Data Block 4.7+](#), page 4-98, block type 78 in series 1):

- User Delete Address
- User Add Hosts

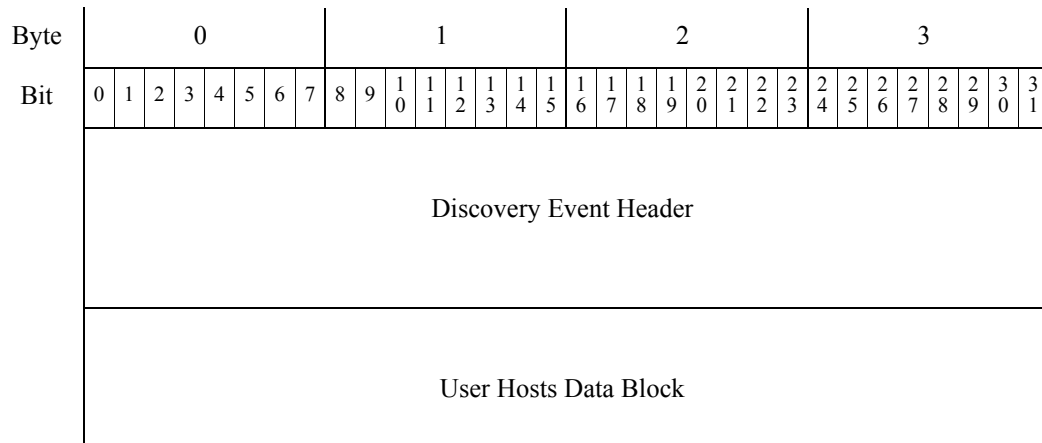

## User Delete Server Message

User Delete Server messages have the standard discovery event header (see [Discovery Event Header 5.2+, page 4-32](#)) followed by a User Server List data block (see [User Server List Data Block, page 4-97](#)). The User Server List data block is block type 77 in series 1.

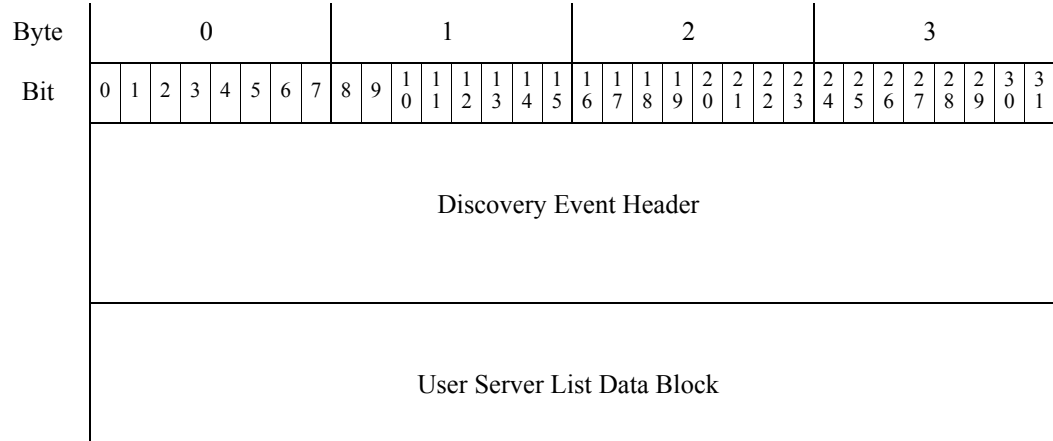

## User Set Host Criticality Messages

User Set Host Criticality messages have the standard discovery event header (see [Discovery Event Header 5.2+, page 4-32](#)) followed by a User Criticality Change data block (see [User Criticality Change Data Block 4.7+, page 4-101](#)). The User Criticality Change data block is block type 81 in series 1.

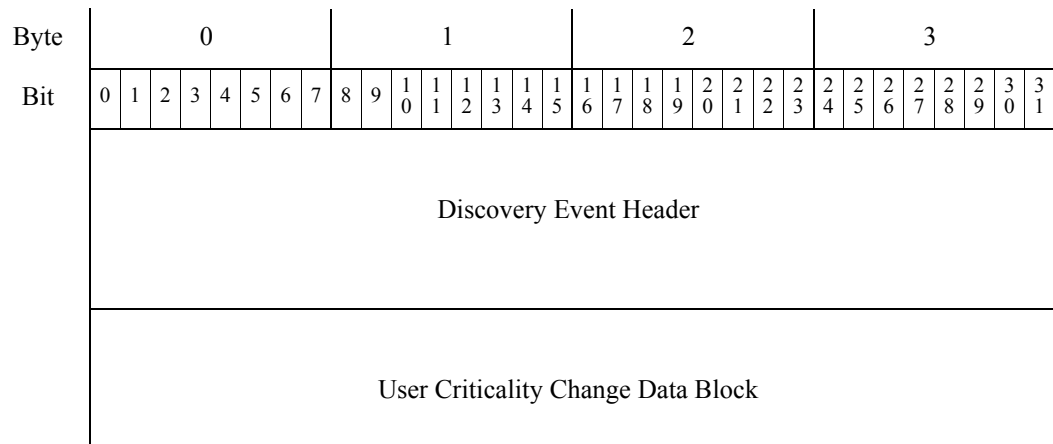

## Attribute Messages

The following event messages have a standard discovery event header (as documented in [Discovery Event Header 5.2+](#), page 4-32) followed by an Attribute Definition data block (as documented in [Attribute Definition Data Block for 4.7+](#), page 4-80, block type 55 in series 1):

- Add Host Attribute
- Update Host Attribute
- Delete Host Attribute

Each of these events use the following format:

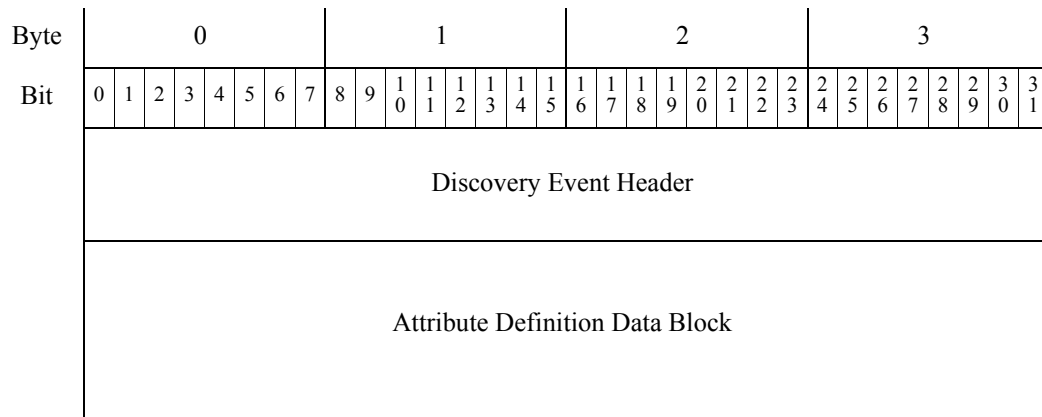

## Attribute Value Messages

The following event messages have a standard discovery event header (as documented in [Discovery Event Header 5.2+](#), page 4-32) followed by a User Attribute Value data block (as documented in [User Attribute Value Data Block 4.7+](#), page 4-102, block type 82 in series 1):

- Set Host Attribute Value
- Delete Host Attribute Value

Each of these events use the following format:

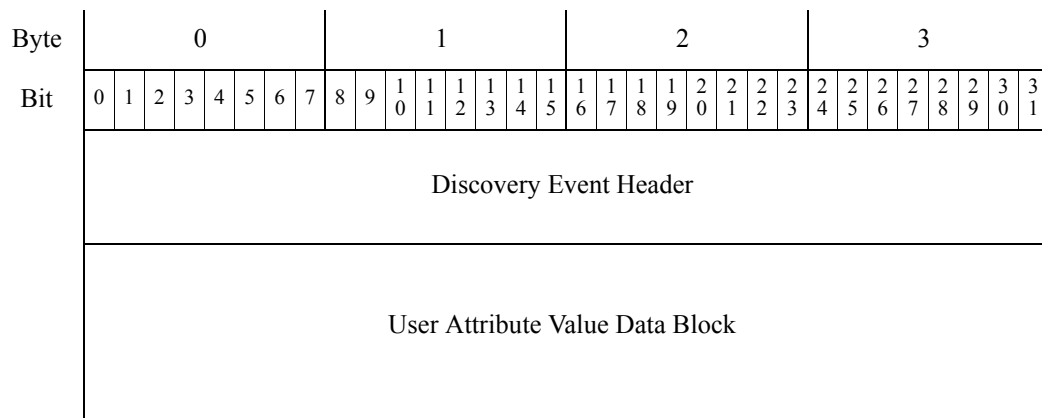

## User Server and Operating System Messages

The following event messages have a standard discovery event header (as documented in [Discovery Event Header 5.2+, page 4-32](#)) followed by a User Product data block (as documented in [User Product Data Block 5.1+, page 4-152](#), block type 60 in series 1):

- Set Operating System Definition
- Set Server Definition
- Add Server

Each of these events use the following format:

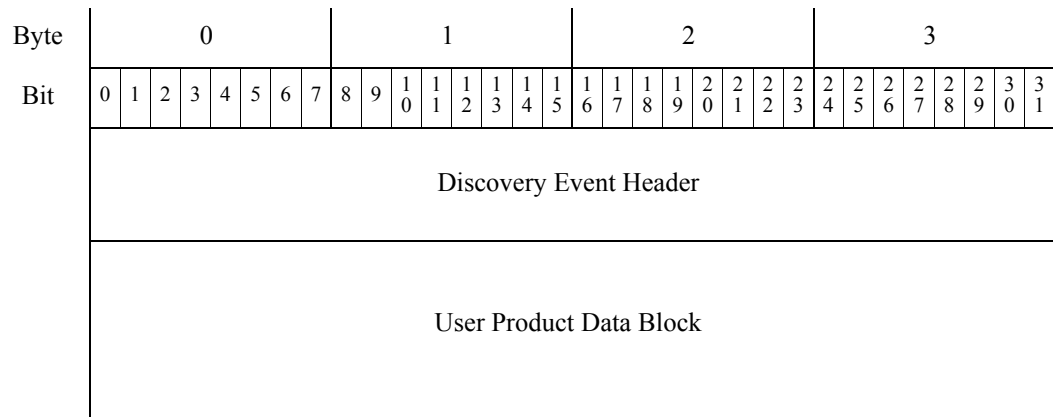

## User Protocol Messages

The following event messages have a standard discovery event header (as documented in [Discovery Event Header 5.2+, page 4-32](#)) followed by a User Protocol List data block (as documented in [User Protocol List Data Block 4.7+, page 4-104](#), block type 83 in series 1):

- Delete Protocol
- Add Protocol

Each of these events use the following format:

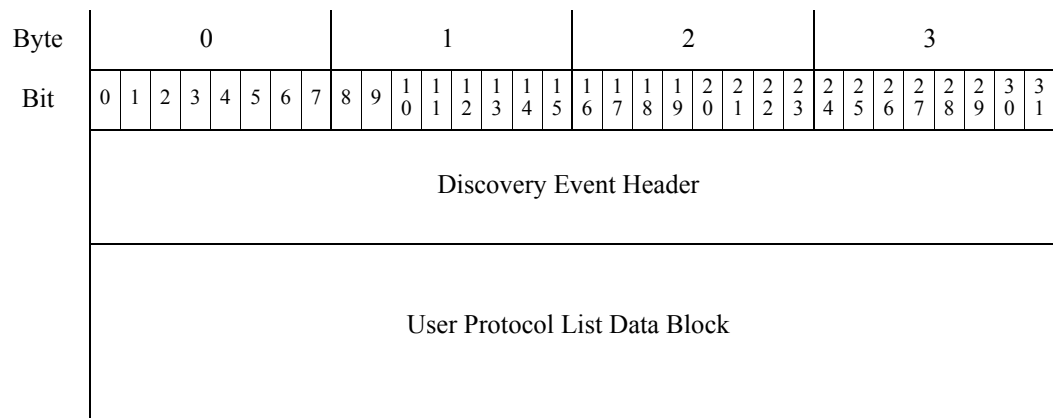

## User Client Application Messages

The following event messages have a standard discovery event header (as documented in [Discovery Event Header 5.2+, page 4-32](#)) followed by a User Client Application List data block (as documented in [User Client Application List Data Block, page 4-86](#), block type 60 in series 1):

- Delete Client Application
- Add Client Application

Each of these events use the following format:

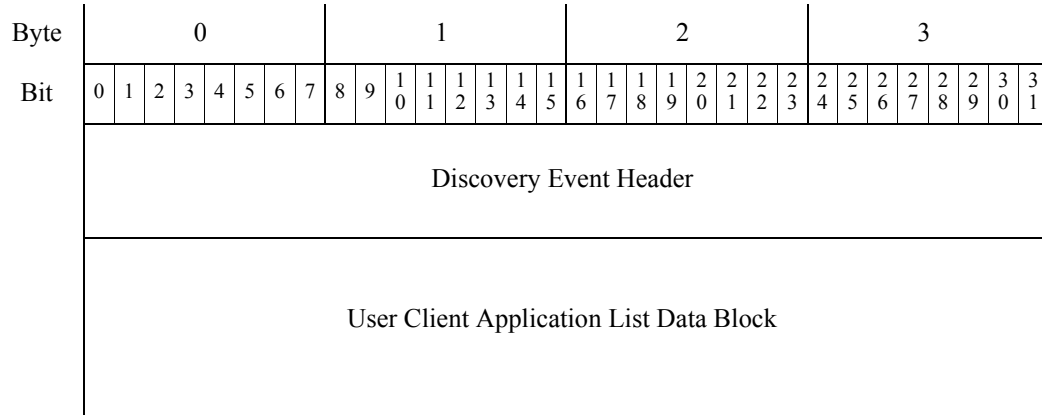

## Add Scan Result Messages

The Add Scan Result event message has a standard discovery event header (as documented in [Discovery Event Header 5.2+, page 4-32](#)) followed by a Scan Results data block (as documented in [Scan Result Data Block 5.2+, page 4-118](#)). The Scan Result data block is block type 142 in series 1.

This event uses the following format:

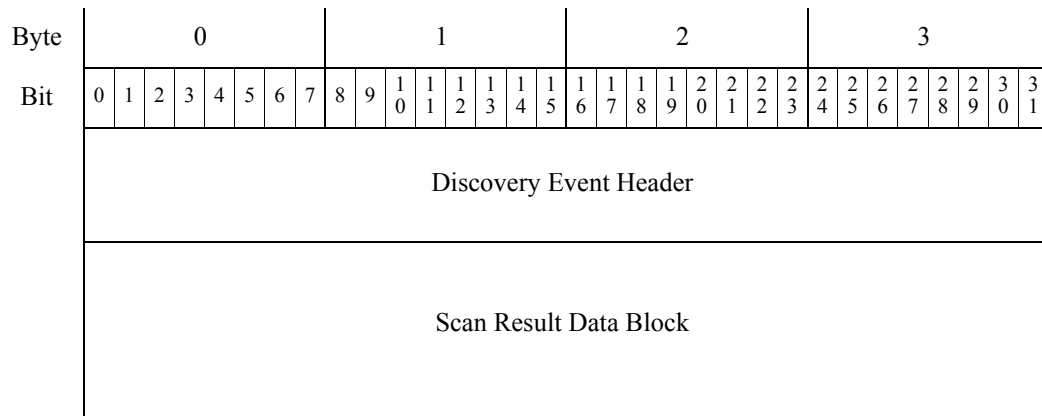



## New Operating System Messages

The New OS event message has a standard discovery event header (as documented in [Discovery Event Header 5.2+, page 4-32](#)) followed by an Operating System Fingerprint data block (as documented in [Operating System Fingerprint Data Block 5.1+, page 4-141](#)).

This event uses the following format:

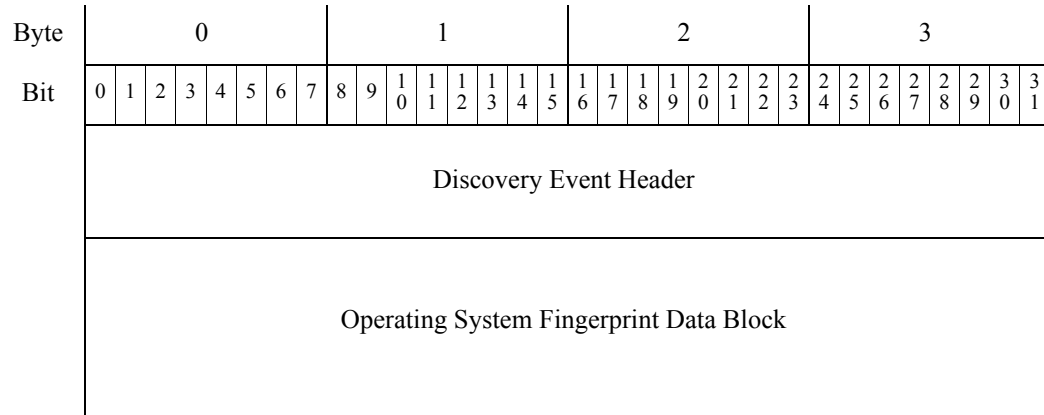

## Identity Conflict and Identity Timeout System Messages

The Identity Conflict and Identity Timeout event messages each have a standard discovery event header (as documented in [Discovery Event Header 5.2+, page 4-32](#)) followed by an Identity data block (as documented in [Identity Data Block, page 4-106](#)). The Identity data block is block type 94 in series 1. These messages are generated when there are conflicts or timeouts in a fingerprint source identity.

This event uses the following format:

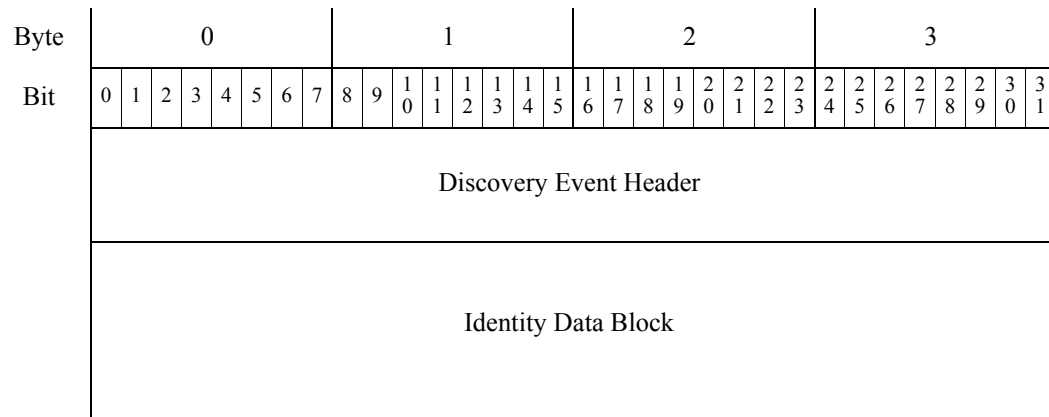

## Host IOC Set Messages

The Host IOC Set message has a standard discovery event header (as documented in [Discovery Event Header 5.2+, page 4-32](#)) followed by an integer data block (as documented in [Integer \(INT32\) Data Block, page 4-69](#)). This integer data block contains the ID number of the IOC set for the host.

This event uses the following format:

| Byte                   | 0 |   |   |   |   |   |   |   | 1 |   |    |    |    |    |    |    | 2  |    |    |    |    |    |    |    | 3  |    |    |    |    |    |    |    |
|------------------------|---|---|---|---|---|---|---|---|---|---|----|----|----|----|----|----|----|----|----|----|----|----|----|----|----|----|----|----|----|----|----|----|
| Bit                    | 0 | 1 | 2 | 3 | 4 | 5 | 6 | 7 | 8 | 9 | 10 | 11 | 12 | 13 | 14 | 15 | 16 | 17 | 18 | 19 | 20 | 21 | 22 | 23 | 24 | 25 | 26 | 27 | 28 | 29 | 30 | 31 |
| Discovery Event Header |   |   |   |   |   |   |   |   |   |   |    |    |    |    |    |    |    |    |    |    |    |    |    |    |    |    |    |    |    |    |    |    |
| Integer Data Block     |   |   |   |   |   |   |   |   |   |   |    |    |    |    |    |    |    |    |    |    |    |    |    |    |    |    |    |    |    |    |    |    |

## User Data Structures by Event Type

eStreamer builds user event messages based on the event type indicated in the discovery event header. The following sub-sections describe the high-level structure for each event type:

- [User Modification Messages, page 4-54](#)
- [User Information Update Message Block, page 4-55](#)

### User Modification Messages

When any of the following events occurs through system detection, a user modification message is sent:

- a new user is detected (a New User Identity event—event type 1004, subtype 1),
- a user is removed (a Delete User Identity event—event type 1004, subtype 3)
- a user is dropped (a User Identity Dropped: User Limit Reached event—event type 1004, subtype 4)

User Modification event messages have a standard discovery event header (as documented in [Discovery Event Header 5.2+, page 4-32](#)) and a User Information data block (as documented in [User Information Data Block, page 4-168](#)). The User Information data block is block type 120 in series 1.

| Byte                        | 0 |   |   |   |   |   |   |   | 1 |   |    |    |    |    |    |    | 2  |    |    |    |    |    |    |    | 3  |    |    |    |    |    |    |    |
|-----------------------------|---|---|---|---|---|---|---|---|---|---|----|----|----|----|----|----|----|----|----|----|----|----|----|----|----|----|----|----|----|----|----|----|
| Bit                         | 0 | 1 | 2 | 3 | 4 | 5 | 6 | 7 | 8 | 9 | 10 | 11 | 12 | 13 | 14 | 15 | 16 | 17 | 18 | 19 | 20 | 21 | 22 | 23 | 24 | 25 | 26 | 27 | 28 | 29 | 30 | 31 |
| Discovery Event Header      |   |   |   |   |   |   |   |   |   |   |    |    |    |    |    |    |    |    |    |    |    |    |    |    |    |    |    |    |    |    |    |    |
| User Information Data Block |   |   |   |   |   |   |   |   |   |   |    |    |    |    |    |    |    |    |    |    |    |    |    |    |    |    |    |    |    |    |    |    |

## User Information Update Message Block

When the login changes for a user (a User Login event—event type 1004, subtype 2) detected by the system, a user information update message is sent.

User Information Update event messages have a standard discovery event header (as documented in [Discovery Event Header 5.2+](#), page 4-32) and a User Login Information data block (as documented in [User Login Information Data Block 5.1+](#), page 4-171). The User Login Information data block is block type 121 in series 1.

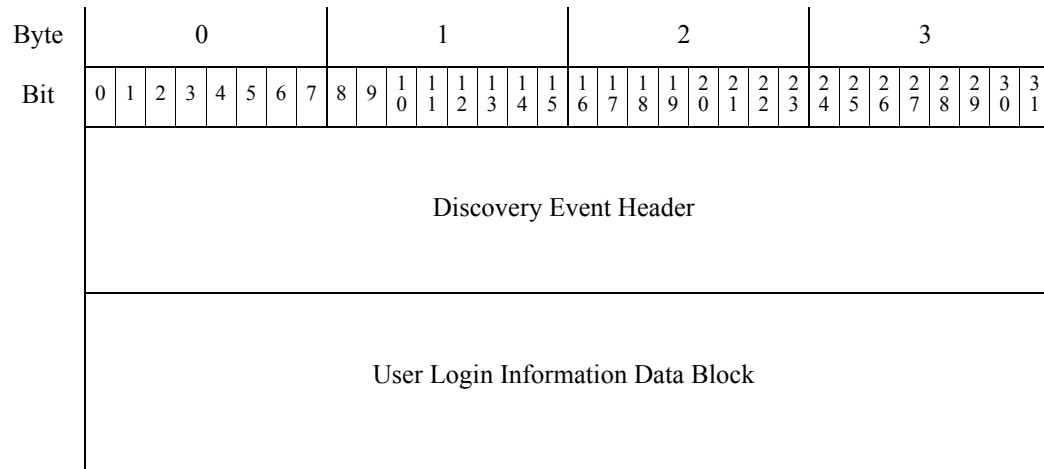

## Understanding Discovery (Series 1) Blocks

Most discovery and connection events incorporate one or more data blocks from the series 1 group of data structures. Each series 1 data block type conveys a particular type of information. The block type number appears in the data block header which precedes the data in the block. For information on block header format, see [Data Block Header](#), page 2-24.

### Series 1 Data Block Header

The series 1 data block header, like the series 2 block header, has two 32-bit integer fields that contain the block's type number and the block length.

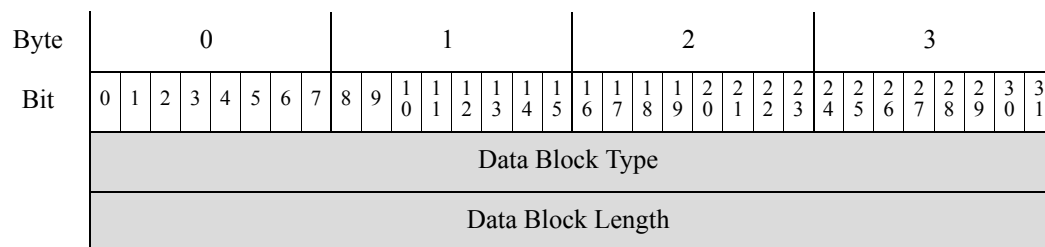

**Note**

The data block length field contains the number of bytes in the entire data block, including the eight bytes of the two data block header fields.

For some block series 1 types, the block header is followed immediately by raw data. In more complex block types, the header may be followed by standard fixed length fields or by the header of a series 1 primitive block that encapsulates another series 1 data block or list of blocks.

## Series 1 Primitive Data Blocks

Both series 1 and series 2 blocks include a set of primitives that encapsulate lists of variable-length blocks as well as variable-length strings and BLOBs within messages. These primitive blocks have the standard series 1 block header discussed above. These primitives appear only within other series 1 data blocks. Any number can be included in a given block type. For details on the structure of the primitive blocks, see the following:

- [String Data Block, page 4-63](#)
- [BLOB Data Block, page 4-64](#)
- [List Data Block, page 4-65](#)
- [Generic List Block, page 4-66](#)

## Host Discovery and Connection Data Blocks

For the list of block types in host discovery and connection events, see [Table 4-27 on page 4-56](#). The block types in user events are described in [Table 4-83 on page 4-159](#). These are all Series 1 data blocks.

Each entry in the table below contains a link to the subsection where the data block is defined. For each block type, the status (current or legacy) is indicated. A current data block is the latest version. A legacy data block is one that is used for an older version of the product, and the message format can still be requested from eStreamer.

*Table 4-27 Host Discovery and Connection Data Block Types*

| Type | Content       | Data Block Status | Description  |
|------|---------------|-------------------|--|
| 0    | String        | Current           | Contains string data. See <a href="#">String Data Block, page 4-63</a> for more information.   |
| 1    | Sub-Server    | Current           | Contains information about a sub-server detected on a server. See <a href="#">Sub-Server Data Block, page 4-66</a> for more information. |
| 4    | Protocol      | Current           | Contains protocol data. See <a href="#">Protocol Data Block, page 4-68</a> for more information.   |
| 7    | Integer Data  | Current           | Contains integer (numeric) data. See <a href="#">Integer (INT32) Data Block, page 4-69</a> for more information.                         |
| 8    | Vulnerability | Current           | Contains vulnerability data. See <a href="#">Vulnerability Reference Data Block, page 4-69</a> for more information.                     |

Table 4-27 Host Discovery and Connection Data Block Types (continued)

| Type | Content                 | Data Block Status | Description  |
|------|-------------------------|-------------------|--|
| 10   | BLOB                    | Current           | Contains a raw block of binary data and is used specifically for banners. See <a href="#">BLOB Data Block</a> , page 4-64 for more information.  |
| 11   | List                    | Current           | Contains a list of other data blocks. See <a href="#">List Data Block</a> , page 4-65 for more information.  |
| 14   | VLAN                    | Current           | Contains VLAN information. See <a href="#">VLAN Data Block</a> , page 4-71 for more information.   |
| 20   | Intrusion Impact Alert  | Current           | Contains intrusion impact alert information. Intrusion impact alert events have slightly different headers than other data blocks. See <a href="#">Intrusion Impact Alert Data 5.3+</a> , page 3-12 for more information.  |
| 31   | Generic List            | Current           | Contains generic list information, for example, to encapsulate lists of blocks, such as Client Application blocks, in the Host Profile block. See <a href="#">Generic List Block</a> , page 4-66 for more information.   |
| 35   | String Information      | Current           | Contains string information. For example, when used in the Scan Vulnerability data block, the String Information data block contains the CVE identification number data. See <a href="#">String Information Data Block</a> , page 4-73.  |
| 37   | Server Banner           | Current           | Contains server banner data. See <a href="#">Server Banner Data Block</a> , page 4-72 for more information.  |
| 38   | Attribute Address       | Legacy            | Contains the host attribute address (as documented in earlier versions of the product). The successor block is 146.  |
| 39   | Attribute List Item     | Current           | Contains a host attribute list item value. See <a href="#">Attribute List Item Data Block</a> , page 4-74 for more information.  |
| 42   | Host Client Application | Legacy            | Contains client application information for New Client Application events (as documented for earlier versions of the product).   |
| 47   | Full Host Profile       | Legacy            | Contains complete host profile information (as documented in earlier versions of the product).   |
| 48   | Attribute Value         | Current           | Contains attribute identification numbers and values for host attributes. See <a href="#">Attribute Value Data Block</a> , page 4-75 for more information.   |
| 51   | Full Sub-Server         | Current           | Contains information about a sub-server detected on a server. Referenced in Full Server information blocks and in full host profiles. Includes vulnerability information for each sub-server. See <a href="#">Full Sub-Server Data Block</a> , page 4-77 for more information. |
| 53   | Operating System        | Current           | Contains operating system information for Version 3.5+. See <a href="#">Operating System Data Block 3.5+</a> , page 4-79 for more information.   |

Table 4-27 Host Discovery and Connection Data Block Types (continued)

| Type | Content                       | Data Block Status | Description   |
|------|-------------------------------|-------------------|---|
| 54   | Policy Engine Control Message | Current           | Contains information on user policy control changes. See <a href="#">Policy Engine Control Message Data Block</a> , page 4-79 for more information.   |
| 55   | Attribute Definition          | Current           | Contains information on attribute definitions. See <a href="#">Attribute Definition Data Block for 4.7+</a> , page 4-80 for more information.   |
| 56   | Connection Statistics         | Legacy            | Contains information for connection statistics events in 4.7 - 4.9.0 (as documented in earlier versions of the product).  |
| 57   | User Protocol                 | Current           | Contains protocol information from user input. See <a href="#">User Protocol Data Block</a> , page 4-83 for more information.   |
| 59   | User Client Application       | Legacy            | Contains client application data from user input. See <a href="#">User Client Application Data Block for 5.0 - 5.1</a> , page B-58 for more information. Superseded by block 138.   |
| 60   | User Client Application List  | Current           | Contains lists of user client application data blocks. See <a href="#">User Client Application List Data Block</a> , page 4-86 for more information.  |
| 61   | IP Range Specification        | Legacy            | Contains IP address range specifications. See <a href="#">IP Range Specification Data Block for 5.0 - 5.1.1.x</a> , page B-167 for more information. Superseded by block 141.   |
| 62   | Attribute Specification       | Current           | Contains an attribute name and value. See <a href="#">Attribute Specification Data Block</a> , page 4-89 for more information.  |
| 63   | MAC Address Specification     | Current           | Contains MAC address range specifications. See <a href="#">MAC Address Specification Data Block</a> , page 4-91 for more information.   |
| 64   | IP Address Specification      | Current           | Contains lists of IP and MAC address specification blocks. See <a href="#">Address Specification Data Block</a> , page 4-92 for more information.   |
| 65   | User Product                  | Legacy            | Contains host input data imported from a third-party application, including third-party application string mappings. See <a href="#">User Product Data Block for 5.0.x</a> , page B-62 for more information. The successor block type 118 introduced for 5.0 has an identical structure as block type 65. |
| 66   | Connection Chunk              | Legacy            | Contains connection chunk information. See <a href="#">Connection Chunk Data Block for 5.0 - 5.1</a> , page B-94 for more information. The successor block type 119 introduced for 5.0 has an identical structure as block type 66.   |
| 67   | Fix List                      | Current           | Contains a fix that applies to a host. See <a href="#">Fix List Data Block</a> , page 4-95 for more information.  |

Table 4-27 Host Discovery and Connection Data Block Types (continued)

| Type | Content                        | Data Block Status | Description  |
|------|--------------------------------|-------------------|--|
| 71   | Generic Scan Results           | Legacy            | Contains results from an Nmap scan (as documented in earlier versions of the product).   |
| 72   | Scan Result                    | Legacy            | Contains results from a third-party scan (as documented in earlier versions of the product).   |
| 76   | User Server                    | Current           | Contains server information from a user input event. See <a href="#">User Server Data Block, page 4-95</a> for more information.   |
| 77   | User Server List               | Current           | Contains lists of user server blocks. See <a href="#">User Server List Data Block, page 4-97</a> for more information.   |
| 78   | User Hosts                     | Current           | Contains information about host ranges from a user host input event. See <a href="#">User Hosts Data Block 4.7+, page 4-98</a> for more information.   |
| 79   | User Vulnerability             | Legacy            | Contains information about a vulnerability for a host or hosts (as documented in earlier versions of the product). The successor block introduced for version 5.0 has block type 124.  |
| 80   | User Host Vulnerability Change | Current           | Contains lists of deactivated or activated vulnerabilities. See <a href="#">User Vulnerability Change Data Block 4.7+, page 4-99</a> for more information.   |
| 81   | User Criticality               | Current           | Contains information on criticality changes for a host or host. See <a href="#">User Criticality Change Data Block 4.7+, page 4-101</a> for more information.  |
| 82   | User Attribute Value           | Current           | Contains attribute value changes for a host or hosts. See <a href="#">User Attribute Value Data Block 4.7+, page 4-102</a> for more information.   |
| 83   | User Protocol List             | Current           | Contains lists of protocols for a host or hosts. See <a href="#">User Protocol List Data Block 4.7+, page 4-104</a> for more information.  |
| 85   | Vulnerability List             | Current           | Contains vulnerabilities that apply to a host. See <a href="#">Host Vulnerability Data Block 4.9.0+, page 4-105</a> for more information.  |
| 86   | Scan Vulnerability             | Legacy            | Contains information on vulnerabilities detected by a scan (as documented in earlier versions of the product).   |
| 87   | Operating System Fingerprint   | Legacy            | Contains lists of operating system fingerprints. See <a href="#">Operating System Fingerprint Data Block for 5.0 - 5.0.2, page B-77</a> for more information. The successor block introduced for version 5.1 has block type 130. |
| 88   | Server Information             | Legacy            | Contains server information used in server fingerprints (as documented in earlier versions of the product).  |
| 89   | Host Server                    | Legacy            | Contains server information for a host (as documented in earlier versions of the product).   |

Table 4-27 Host Discovery and Connection Data Block Types (continued)

| Type | Content                 | Data Block Status | Description   |
|------|-------------------------|-------------------|---|
| 90   | Full Host Server        | Legacy            | Contains server information for a host (as documented in earlier versions of the product).  |
| 91   | Host Profile            | Legacy            | Contains profile information for a host. See <a href="#">Host Profile Data Block for 5.2+, page 4-144</a> for more information. The successor block introduced for version 5.1 has block type 132.                              |
| 92   | Full Host Profile       | Legacy            | Contains complete host profile information (as documented in earlier versions of the product). Supersedes data block 47.  |
| 94   | Identity Data           | Current           | Contains identity data for a host. See <a href="#">Identity Data Block, page 4-106</a> for more information.  |
| 95   | Host MAC Address        | Current           | Contains MAC address information for a host. See <a href="#">Host MAC Address 4.9+, page 4-108</a> for more information.  |
| 96   | Secondary Host Update   | Current           | Contains lists of MAC address information reported by a secondary <a href="#">Secondary Host Update, page 4-109</a> .   |
| 97   | Web Application         | Legacy            | Contains lists of web application data (as documented in earlier versions of the product). The successor block introduced for version 5.0 has block type 123.   |
| 98   | Host Server             | Legacy            | Contains server information for a host (as documented in earlier versions of the product).  |
| 99   | Full Host Server        | Legacy            | Contains server information for a host (as documented in earlier versions of the product).  |
| 100  | Host Client Application | Legacy            | Contains client application information for New Client Application events (as documented in earlier versions of the product). The successor block type 122 introduced for version 5.0 has the same structure as block type 100. |
| 101  | Connection Statistics   | Legacy            | Contains information for connection statistics events in 4.9.1+ (as documented in earlier versions of the product).   |
| 102  | Scan Results            | Legacy            | Contains information about a vulnerability and is used within Add Scan Result events. See <a href="#">Scan Result Data Block 5.0 - 5.1.1.x, page B-60</a> .   |
| 103  | Host Server             | Current           | Contains server information for a host. See <a href="#">Host Server Data Block 4.10.0+, page 4-120</a> for more information.  |
| 104  | Full Host Server        | Current           | Contains server information for a host. See <a href="#">Full Host Server Data Block 4.10.0+, page 4-122</a> for more information.   |



Table 4-27 Host Discovery and Connection Data Block Types (continued)

| Type | Content                      | Data Block Status | Description   |
|------|------------------------------|-------------------|---|
| 105  | Server Information           | Legacy            | Contains server information used in server fingerprints. See <a href="#">Server Information Data Block for 4.10.x, 5.0 - 5.0.2, page 4-126</a> for more information. The successor block type 117 introduced for 5.0 has an identical structure as block type 105.  |
| 106  | Full Server Information      | Current           | Contains information about a server detected on a host. See <a href="#">Full Server Information Data Block, page 4-128</a> for more information.  |
| 108  | Generic Scan Results         | Current           | Contains results from an Nmap scan. See <a href="#">Generic Scan Results Data Block for 4.10.0+, page 4-131</a> for more information.   |
| 109  | Scan Vulnerability           | Current           | Contains information on vulnerabilities detected by a third-party scan. See <a href="#">Scan Vulnerability Data Block for 4.10.0+, page 4-133</a> .   |
| 111  | Full Host Profile            | Legacy            | Contains complete host profile information. See <a href="#">Full Host Profile Data Block 5.0 - 5.0.2, page B-131</a> for more information. Supersedes data block 92.  |
| 112  | Full Host Client Application | Current           | Contains client application information for New Client Application events and includes a list of vulnerabilities. See <a href="#">Full Host Client Application Data Block 5.0+, page 4-136</a> for more information.  |
| 115  | Connection Statistics        | Legacy            | Contains information for connection statistics events in 5.0 - 5.0.2. See <a href="#">Connection Statistics Data Block 5.0 - 5.0.2, page B-78</a> for more information. The successor block introduced for version 5.1 has block type 126.  |
| 117  | Server Information           | Current           | Contains server information used in server fingerprints. See <a href="#">Server Information Data Block for 4.10.x, 5.0 - 5.0.2, page 4-126</a> for more information.  |
| 118  | User Product                 | Legacy            | Contains host input data imported from a third-party application, including third-party application string mappings. See <a href="#">User Product Data Block for 5.0.x, page B-62</a> for more information. The predecessor block type 65, superseded in 5.0, has the same structure as this block type. The successor block introduced for version 5.1 has block type 132. |
| 119  | Connection Chunk             | Legacy            | Contains connection chunk information for versions 4.10.1 - 5.1. See <a href="#">Connection Chunk Data Block for 5.0 - 5.1, page B-94</a> for more information. The successor block is 136.   |
| 122  | Host Client Application      | Current           | Contains client application information for New Client Application events for version 5.0+. See <a href="#">Host Client Application Data Block for 5.0+, page 4-137</a> for more information. It supersedes block type 100.   |

Table 4-27 Host Discovery and Connection Data Block Types (continued)

| Type | Content                      | Data Block Status | Description  |
|------|------------------------------|-------------------|--|
| 123  | Web Application              | Current           | Contains web application data for version 5.0+. See <a href="#">Web Application Data Block for 5.0+</a> , page 4-110 for more information. It supersedes block type 97.  |
| 124  | User Vulnerability           | Current           | Contains information about a vulnerability for a host or hosts. See <a href="#">User Vulnerability Data Block 5.0+</a> , page 4-139. It supersedes block type 79.  |
| 125  | Connection Statistics        | Legacy            | Contains information for connection statistics events in 4.10.2 (as documented in earlier versions of the product). The successor block introduced for version 5.1 has block type 115.   |
| 126  | Connection Statistics        | Legacy            | Contains information for connection statistics events in 5.1. See <a href="#">Connection Statistics Data Block 5.1</a> , page B-83 for more information. It supersedes block type 115. This block type is superseded by block type 137.                  |
| 130  | Operating System Fingerprint | Current           | Contains lists of operating system fingerprints. See <a href="#">Operating System Fingerprint Data Block 5.1+</a> , page 4-141 for more information. It supersedes block type 87.  |
| 131  | Mobile Device Information    | Current           | Contains information about a detected mobile device's hardware. See <a href="#">Mobile Device Information Data Block for 5.1+</a> , page 4-143 for more information.   |
| 132  | Host Profile                 | Legacy            | Contains profile information for a host. See <a href="#">Full Host Profile Data Block 5.2.x</a> , page B-149 for more information. It supersedes block type 91. Superseded by block 139.   |
| 134  | User Product                 | Current           | Contains host input data imported from a third-party application, including third-party application string mappings. See <a href="#">User Product Data Block 5.1+</a> , page 4-152 for more information. This supersedes the predecessor block type 118. |
| 135  | Full Host Profile            | Legacy            | Contains complete host profile information. See <a href="#">Full Host Profile Data Block 5.1.1</a> , page B-140 for more information. Supersedes data block 111.   |
| 136  | Connection Chunk             | Current           | Contains connection chunk information. See <a href="#">Connection Chunk Data Block for 5.1.1+</a> , page 4-93 for more information. Supersedes block 119.  |
| 137  | Connection Statistics        | Legacy            | Contains information for connection events in 5.1.1. See <a href="#">Connection Chunk Data Block for 5.0 - 5.1</a> , page B-94 for more information. It supersedes block type 126. It is superseded by block type 144.                                   |

Table 4-27 Host Discovery and Connection Data Block Types (continued)

| Type | Content                 | Data Block Status | Description  |
|------|-------------------------|-------------------|--|
| 138  | User Client Application | Current           | Contains client application data from user input. See <a href="#">User Client Application Data Block for 5.1.1+</a> , page 4-85 for more information. It supersedes block type 59. |
| 139  | Host Profile            | Current           | Contains profile information for a host. See <a href="#">Host Profile Data Block for 5.2+</a> , page 4-144 for more information. It supersedes block type 132.                     |
| 140  | Full Host Profile       | Legacy            | Contains complete host profile information. See <a href="#">Full Host Profile Data Block 5.3+</a> , page 5-1 for more information. Supersedes data block 135.                      |
| 141  | IP Range Specification  | Current           | Contains IP address range specifications. See <a href="#">IP Address Range Data Block for 5.2+</a> , page 4-88 for more information. It supersedes block 61.                       |
| 142  | Scan Results            | Current           | Contains information about a vulnerability and is used within Add Scan Result events. See <a href="#">Scan Result Data Block 5.2+</a> , page 4-118. It supersedes block 102.       |
| 143  | Host IP                 | Current           | Contains a host's IP address and last seen information. See <a href="#">Host IP Address Data Block</a> , page 4-90 for more information.   |
| 144  | Connection Statistics   | Legacy            | Contains information for connection events in 5.2.x. See <a href="#">Connection Statistics Data Block 5.2.x</a> , page B-89 for more information. It supersedes block type 137.    |
| 146  | Attribute Address       | Current           | Contains the host attribute address for 5.2+. See <a href="#">Attribute Address Data Block 5.2+</a> , page 4-73 for more information. It supersedes block type 38.                 |
| 140  | Full Host Profile       | Current           | Contains complete host profile information. See <a href="#">Full Host Profile Data Block 5.3+</a> , page 5-1 for more information. Supersedes data block 135.                      |
| 152  | Connection Statistics   | Legacy            | Contains information for connection events in 5.3+. See <a href="#">Connection Statistics Data Block 5.3</a> , page B-102 for more information. It supersedes block type 144.      |
| 154  | Connection Statistics   | Current           | Contains information for connection events in 5.3+. See <a href="#">Connection Statistics Data Block 5.3.1+</a> , page 4-111 for more information. It supersedes block type 152.   |

## String Data Block

The String data block is used for sending string data in series 1 blocks. It commonly appears within other series 1 data blocks to describe, for example, operating system or server names.

Empty string data blocks (string data blocks containing no string data) have a block length value of 8 and are followed by zero bytes of string data. An empty string data block is returned when there is no content for the string value, as might happen, for example, in the OS vendor string field in an Operating System data block when the vendor of the operating system is unknown.

The String data block has a block type of 0 in the series 1 group of blocks.

**Note**

Strings returned in this data block are not always null-terminated (that is, they are not always terminated with a 0).

The following diagram shows the format of the String data block:

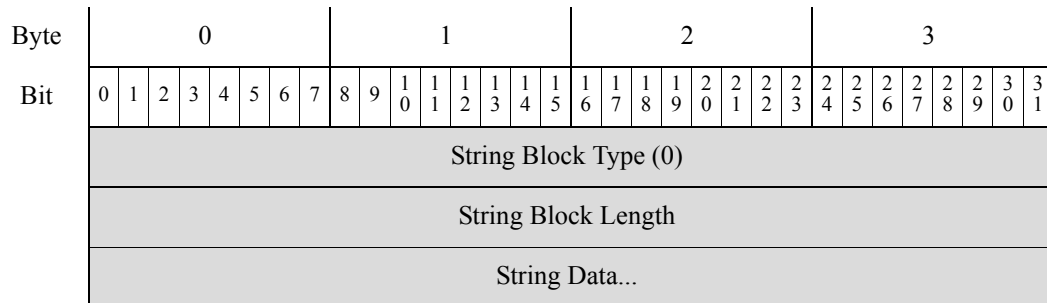

The following table describes the fields of the String data block.

**Table 4-28** String Data Block Fields

| Field               | Data Type | Description  |
|---------------------|-----------|--|
| String Block Type   | uint32    | Initiates a String data block. This value is always 0.   |
| String Block Length | uint32    | Combined length of the string data block header and string data.                                       |
| String Data         | string    | Contains the string data and may contain a terminating character (null byte) at the end of the string. |

## BLOB Data Block

The BLOB data block can be used to convey binary data. For example, it is used to hold the server banner captured by the system. The BLOB data block has a block type of 10 in the series 1 group of blocks.

The following diagram shows the format of the BLOB data block:

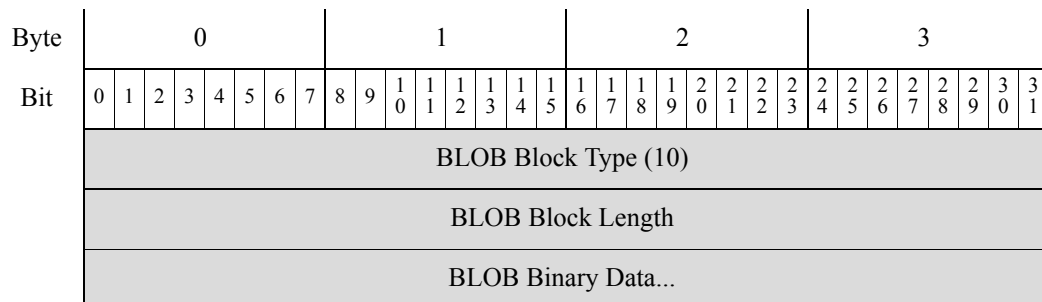

The following table describes the fields of the BLOB data block.

*Table 4-29 BLOB Data Block Fields*

| Field             | Data Type | Description   |
|-------------------|-----------|---|
| BLOB Block Type   | uint32    | Initiates a BLOB data block. This value is always 10.   |
| BLOB Block Length | uint32    | Number of bytes in the BLOB data block, including eight bytes for the BLOB block type and length fields, plus the length of the binary data that follows. |
| Binary Data       | variable  | Contains binary data, typically a server banner.  |

## List Data Block

The List data block is used to encapsulate a list of series 1 data blocks. For example, if a list of TCP servers is being transmitted, the Server data blocks containing the data are encapsulated in a List data block. The List data block has a block type of 11 in the series 1 group of blocks.

The following diagram shows the basic format of a List data block:

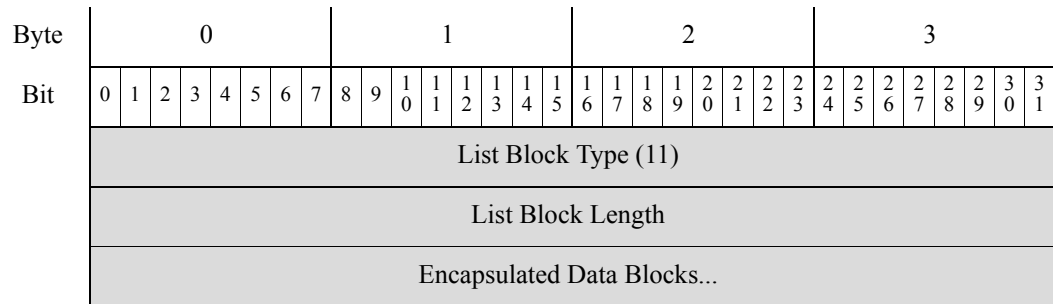

The following table describes the fields of the List data block.

*Table 4-30 List Data Block Fields*

| Field                    | Data Type | Description   |
|--------------------------|-----------|---|
| List Block Type          | uint32    | Initiates a List data block. This value is always 11.   |
| List Block Length        | uint32    | Number of bytes in the list block and encapsulated data. For example, if there were three sub-server data blocks included in the list, the value here would include the number of bytes in the sub-server blocks, plus eight bytes for the list block header. |
| Encapsulated Data Blocks | variable  | Encapsulated data blocks up to the maximum number of bytes in the list block length.  |

## Generic List Block

The Generic List data block is used to encapsulate a list of series 1 data blocks. For example, when client application information is transmitted within a Host Profile data block, a list of Client Application data blocks are encapsulated by the Generic List data block. The Generic List data block has a block type of 31 in the series 1 group of blocks.

The following diagram shows the basic structure of a Generic List data block:

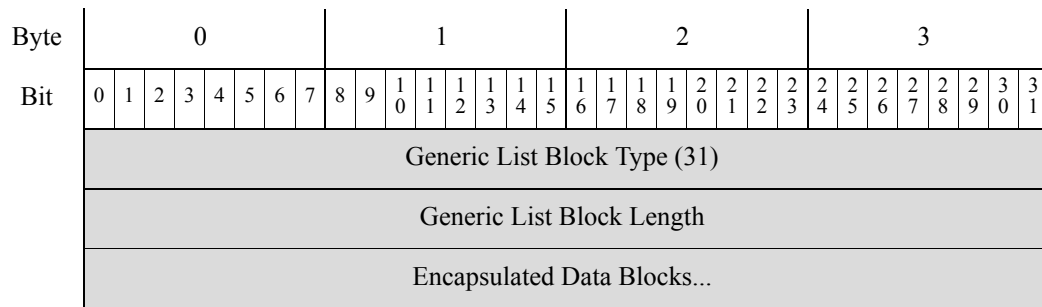

The following table describes the fields of the Generic List data block.

**Table 4-31** Generic List Data Block Fields

| Field                     | Number of Bytes | Description  |
|---------------------------|-----------------|--|
| Generic List Block Type   | uint32          | Initiates a Generic List data block. This value is always 31.  |
| Generic List Block Length | uint32          | Number of bytes in the Generic List block and encapsulated data blocks. This number includes the eight bytes of the generic list block header fields, plus the number of bytes in all of the encapsulated data blocks. |
| Encapsulated Data Blocks  | variable        | Encapsulated data blocks up to the maximum number of bytes in the list block length.   |

## Sub-Server Data Block

The Sub-Server data block conveys information about an individual sub-server, which is a server called by another server on the same host and has associated vulnerabilities. The Sub-Server data block has a block type of 1 in the series 1 group of blocks.

The following diagram shows the format of the Sub-Server data block:

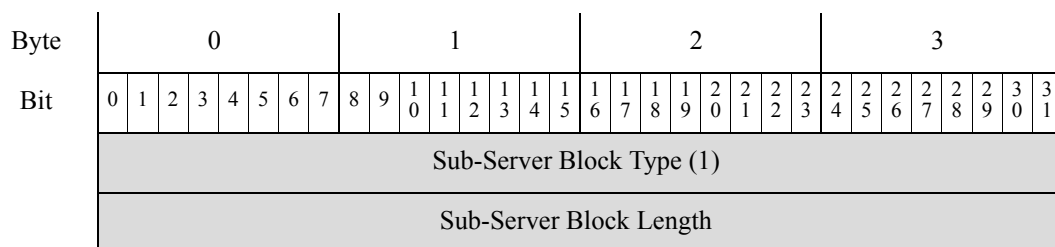

| Byte            | 0                     |   |   |   |   |   |   |   | 1 |   |    |    |    |    |    |    | 2  |    |    |    |    |    |    |    | 3  |    |    |    |    |    |    |    |
|-----------------|-----------------------|---|---|---|---|---|---|---|---|---|----|----|----|----|----|----|----|----|----|----|----|----|----|----|----|----|----|----|----|----|----|----|
|                 | 0                     | 1 | 2 | 3 | 4 | 5 | 6 | 7 | 8 | 9 | 10 | 11 | 12 | 13 | 14 | 15 | 16 | 17 | 18 | 19 | 20 | 21 | 22 | 23 | 24 | 25 | 26 | 27 | 28 | 29 | 30 | 31 |
| Sub-Server Name | String Block Type (0) |   |   |   |   |   |   |   |   |   |    |    |    |    |    |    |    |    |    |    |    |    |    |    |    |    |    |    |    |    |    |    |
|                 | String Block Length   |   |   |   |   |   |   |   |   |   |    |    |    |    |    |    |    |    |    |    |    |    |    |    |    |    |    |    |    |    |    |    |
|                 | Sub-Server Name...    |   |   |   |   |   |   |   |   |   |    |    |    |    |    |    |    |    |    |    |    |    |    |    |    |    |    |    |    |    |    |    |
| Vendor Name     | String Block Type (0) |   |   |   |   |   |   |   |   |   |    |    |    |    |    |    |    |    |    |    |    |    |    |    |    |    |    |    |    |    |    |    |
|                 | String Block Length   |   |   |   |   |   |   |   |   |   |    |    |    |    |    |    |    |    |    |    |    |    |    |    |    |    |    |    |    |    |    |    |
|                 | Vendor Name...        |   |   |   |   |   |   |   |   |   |    |    |    |    |    |    |    |    |    |    |    |    |    |    |    |    |    |    |    |    |    |    |
| Version         | String Block Type (0) |   |   |   |   |   |   |   |   |   |    |    |    |    |    |    |    |    |    |    |    |    |    |    |    |    |    |    |    |    |    |    |
|                 | String Block Length   |   |   |   |   |   |   |   |   |   |    |    |    |    |    |    |    |    |    |    |    |    |    |    |    |    |    |    |    |    |    |    |
|                 | Version...            |   |   |   |   |   |   |   |   |   |    |    |    |    |    |    |    |    |    |    |    |    |    |    |    |    |    |    |    |    |    |    |

The following table describes the fields of the Sub-Server data block.

**Table 4-32 Sub-Server Data Block Fields**

| Field                   | Data Type | Description   |
|-------------------------|-----------|---|
| Sub-Server Block Type   | uint32    | Initiates a Sub-Server data block. This value is always 1.  |
| Sub-Server Block Length | uint32    | Total number of bytes in the Sub-Server data block, including eight bytes for the Sub-Server block type and length fields, plus the number of bytes of data that follows. |
| String Block Type       | uint32    | Initiates a String data block containing the sub-server name. This value is always 0.   |
| String Block Length     | uint32    | Number of bytes in the sub-server name String data block, including the string block type and length fields, plus the number of bytes in the sub-server name.             |
| Sub-Server Name         | string    | Name of the sub-server.   |
| String Block Type       | uint32    | Initiates a String data block that contains the sub-server vendor. This value is always 0.  |
| String Block Length     | uint32    | Number of bytes in the vendor name String data block, including the string block type and length fields, plus the number of bytes in the vendor name.                     |
| Vendor Name             | string    | Sub-server vendor name.   |
| String Block Type       | uint32    | Initiates a String data block that contains the sub-server version. This value is always 0.   |
| String Block Length     | uint32    | Number of bytes in the Sub-Server version String data block, including the string block type and length fields, plus the number of bytes in the version.                  |
| Version                 | string    | Sub-server version.   |

## Protocol Data Block

The Protocol data block defines protocols. It is a very simple data block, with only the block type, block length, and the IANA protocol number identifying the protocol. The Protocol data block has a block type of 4 in the series 1 group of blocks.

The following graphic shows the format of the Protocol data block:

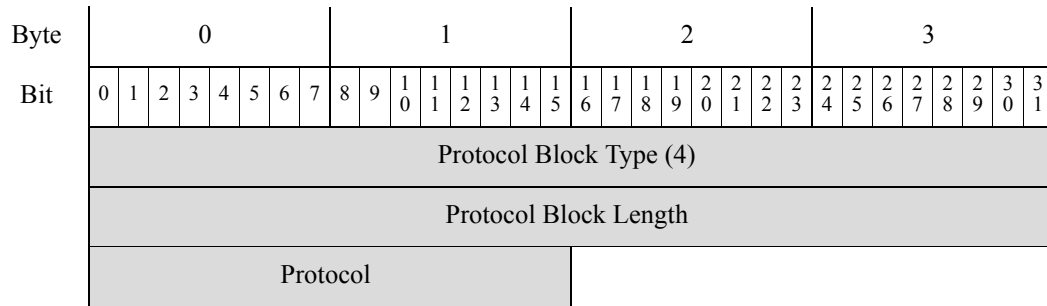

The following table describes the fields of the Protocol data block.

**Table 4-33** Protocol Data Block Fields

| Field                 | Data Type | Description   |
|-----------------------|-----------|---|
| Protocol Block Type   | uint32    | Initiates a Protocol data block. This value is always 4.  |
| Protocol Block Length | uint32    | Number of bytes in the Protocol data block. This value is always 10.  |
| Protocol              | uint16    | IANA protocol number or Ethertype. This is handled differently for Transport and Network layer protocols.<br><br>Transport layer protocols are identified by the IANA protocol number. For example: <ul style="list-style-type: none"> <li>• 6 - TCP</li> <li>• 17 - UDP</li> </ul> Network layer protocols are identified by the decimal form of the IEEE Registration Authority Ethertype. For example: <ul style="list-style-type: none"> <li>• 2048 - IP</li> </ul> |



## Integer (INT32) Data Block

The Integer (INT32) data block is used in List data blocks to convey 32-bit integer data, for example, in the Vulnerability Reference data block where it is used to transmit a list of vulnerability identification numbers.

The Integer data block has a block type of 7 in the series 1 group of blocks.

The following diagram shows the format of the integer data block:

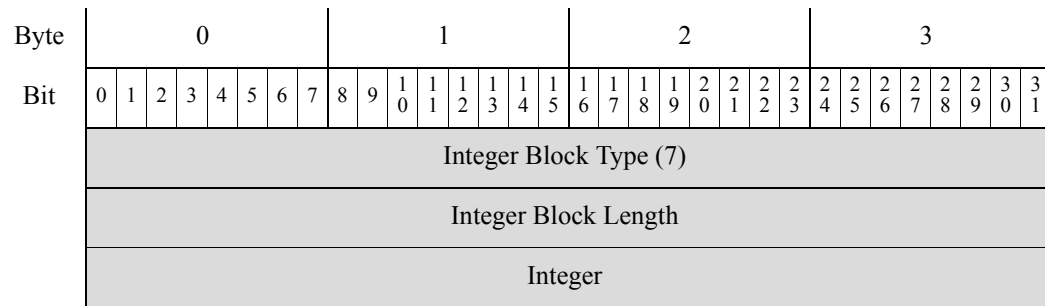

The following table describes the fields of the Integer data block:

**Table 4-34** Integer Data Block Fields

| Field                | Data Type | Description   |
|----------------------|-----------|---|
| Integer Block Type   | uint32    | Initiates an Integer data block. The value is always 7.             |
| Integer Block Length | uint32    | Number of bytes in the Integer data block. This value is always 12. |
| Integer              | uint32    | Contains the integer value.   |

## Vulnerability Reference Data Block

The Vulnerability Reference data block describes the list of vulnerabilities to which a host is subject, including the affected port, protocol, server, and list of related vulnerabilities. The Vulnerability Reference data block has a block type of 8 in the series 1 group of blocks.



**Note**

An asterisk (\*) next to a series 1 data block name in the following diagram indicates the message may contain zero or more instances of the block.

The following diagram shows the format of the Vulnerability Reference data block:

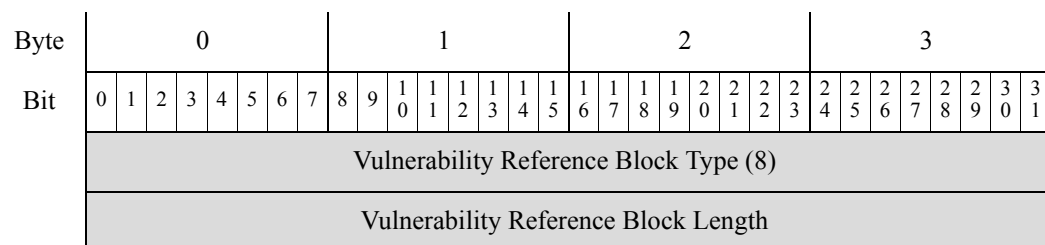

| Byte | 0  |   |   |   |   |   |   |   | 1 |   |    |    |    |    |    |    | 2                     |    |    |    |    |    |    |    | 3  |    |    |    |    |    |    |    |
|------|--|---|---|---|---|---|---|---|---|---|----|----|----|----|----|----|-----------------------|----|----|----|----|----|----|----|----|----|----|----|----|----|----|----|
| Bit  | 0  | 1 | 2 | 3 | 4 | 5 | 6 | 7 | 8 | 9 | 10 | 11 | 12 | 13 | 14 | 15 | 16                    | 17 | 18 | 19 | 20 | 21 | 22 | 23 | 24 | 25 | 26 | 27 | 28 | 29 | 30 | 31 |
|      | Port                                       |   |   |   |   |   |   |   |   |   |    |    |    |    |    |    | String Block Type (0) |    |    |    |    |    |    |    |    |    |    |    |    |    |    |    |
|      | String Block Type, continued               |   |   |   |   |   |   |   |   |   |    |    |    |    |    |    | String Block Length   |    |    |    |    |    |    |    |    |    |    |    |    |    |    |    |
|      | String Block Length, continued             |   |   |   |   |   |   |   |   |   |    |    |    |    |    |    | Protocol Name...      |    |    |    |    |    |    |    |    |    |    |    |    |    |    |    |
|      | String Block Type (0)                      |   |   |   |   |   |   |   |   |   |    |    |    |    |    |    |                       |    |    |    |    |    |    |    |    |    |    |    |    |    |    |    |
|      | String Block Length                        |   |   |   |   |   |   |   |   |   |    |    |    |    |    |    |                       |    |    |    |    |    |    |    |    |    |    |    |    |    |    |    |
|      | Sub-Server Name...                         |   |   |   |   |   |   |   |   |   |    |    |    |    |    |    |                       |    |    |    |    |    |    |    |    |    |    |    |    |    |    |    |
|      | List Block Type (11)                       |   |   |   |   |   |   |   |   |   |    |    |    |    |    |    |                       |    |    |    |    |    |    |    |    |    |    |    |    |    |    |    |
|      | List Block Length                          |   |   |   |   |   |   |   |   |   |    |    |    |    |    |    |                       |    |    |    |    |    |    |    |    |    |    |    |    |    |    |    |
|      | (Vulnerability ID) Integer Data Block(s) * |   |   |   |   |   |   |   |   |   |    |    |    |    |    |    |                       |    |    |    |    |    |    |    |    |    |    |    |    |    |    |    |

The following table describes the fields of the Vulnerability Reference data block:

**Table 4-35** Vulnerability Reference Data Block Fields

| Field                                | Data Type | Description   |
|--------------------------------------|-----------|---|
| Vulnerability Reference Block Type   | uint32    | Initiates a Vulnerability Reference data block. This value is always 8.   |
| Vulnerability Reference Block Length | uint32    | Number of bytes in the Vulnerability Reference data block, including eight bytes for the vulnerability reference block type and length fields, plus the number of bytes of vulnerability reference data that follows. |
| Port                                 | uint16    | Port used by the sub-server affected by the listed vulnerabilities.   |
| String Block Type                    | uint32    | Initiates a String data block for the protocol affected by the listed vulnerabilities. This value is set to 0.  |
| String Block Length                  | uint32    | Number of bytes in the String data block for the protocol name, including eight bytes for the string block type and length fields, plus the number of bytes in the protocol name.                                     |
| Protocol Name                        | string    | Contains the name of the protocol used by the sub-server affected by the listed vulnerabilities.  |
| String Block Type                    | uint32    | Initiates a String data block for the sub-server affected by the vulnerability.   |
| String Block Length                  | uint32    | Number of bytes in the String data block containing the sub-server name, including eight bytes for the String block type and length fields, plus the number of bytes in the sub-server name.                          |
| Sub-Server                           | string    | Contains the name of the sub-server affected by the listed vulnerabilities.   |

Table 4-35 Vulnerability Reference Data Block Fields (continued)

| Field                                  | Data Type | Description  |
|--|-----------|--|
| List Block Type                        | uint32    | Initiates a list that contains zero or more VDB vulnerability ID numbers encapsulated in Integer data blocks.  |
| List Block Length                      | uint32    | Number of bytes in the vulnerability ID list, including eight bytes for the list block type and length fields, plus the number of bytes in the encapsulated Integer data blocks.                               |
| (Vulnerability ID) Integer Data Blocks | variable  | Contains zero or more Integer data blocks containing vulnerability identification numbers. See <a href="#">Integer (INT32) Data Block, page 4-69</a> for the data fields that appear in an Integer data block. |

## VLAN Data Block

The VLAN data block contains VLAN tag information for a host. The VLAN data block has a block type of 14 in the series 1 group of blocks. The following diagram shows the format of the VLAN data block:

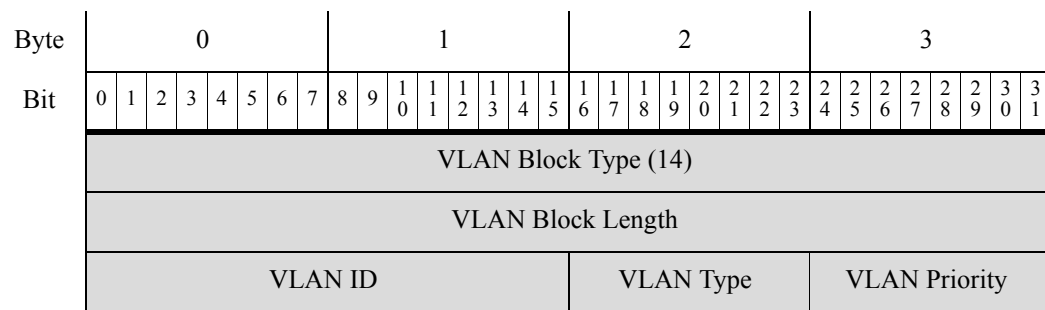

The following table describes the fields of the VLAN data block.

Table 4-36 VLAN Data Block Fields

| Field             | Data Type | Description   |
|-------------------|-----------|---|
| VLAN Block Type   | uint32    | Initiates a VLAN data block. This value is always 14.   |
| VLAN Block Length | uint32    | Number of bytes in the VLAN data block. This value is always 12.  |
| VLAN ID           | uint16    | Contains the VLAN identification number that indicates which VLAN the host is a member of.  |
| VLAN Type         | uint8     | Type of packet encapsulated in the VLAN tag. <ul style="list-style-type: none"> <li>0 - Ethernet</li> <li>1 - Token Ring</li> </ul> |
| VLAN Priority     | uint8     | Priority value included in the VLAN tag.  |

## Server Banner Data Block

The Server Banner data block provides information about the banner for a server running on a host. It contains the server port, protocol, and the banner data. The Server Banner data block has a block type of 37 in the series 1 group of blocks.

The following diagram shows the format of the Server Banner data block.

**Note**

An asterisk(\*) next to a block type field in the following diagram indicates the message may contain zero or more instances of the series 1 data block.

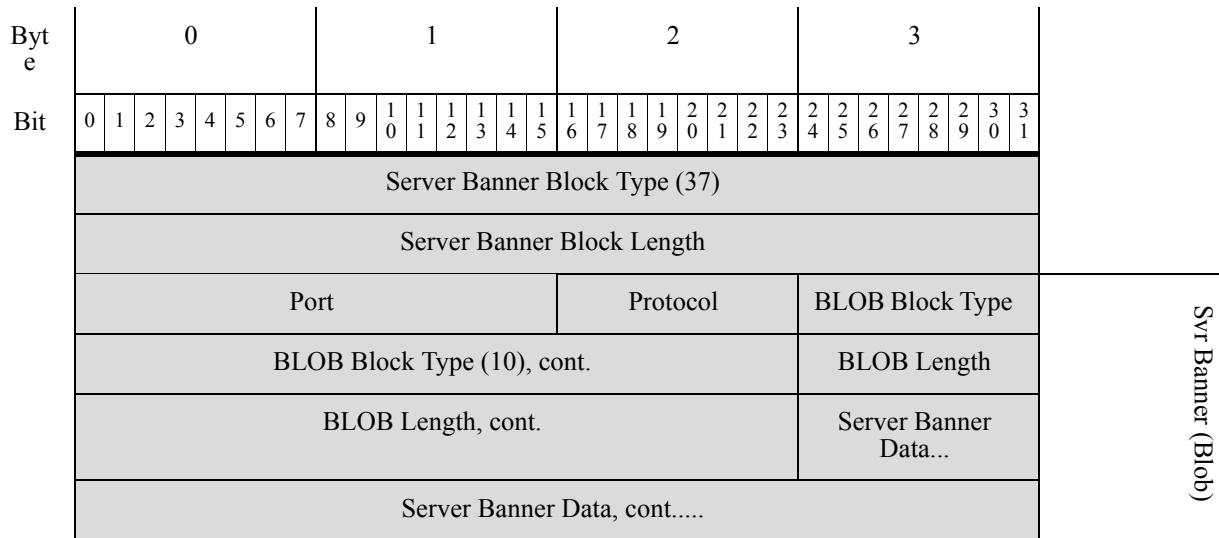

The following table describes the fields of the Server Banner data block.

**Table 4-37** Server Banner Data Block Fields

| Field                      | Data Type | Description  |
|----------------------------|-----------|--|
| Server Banner Block Type   | uint32    | Initiates a Server Banner data block. This value is always 37.   |
| Server Banner Block Length | uint32    | Total number of bytes in the Server Banner data block, including the eight bytes in the server banner block type and length fields, plus the number of bytes of data that follows. |
| Port                       | uint16    | Port number on which the server runs.  |
| Protocol                   | uint8     | Protocol number for the server.  |
| BLOB Block Type            | uint32    | Initiates a BLOB data block containing server banner data. This value is always 10.  |
| Length                     | uint32    | Total number of bytes in the BLOB data block (typically 264 bytes).  |
| Banner                     | byte[n]   | First <i>n</i> bytes of the packet involved in the server event, where <i>n</i> is equal to or less than 256.  |

## String Information Data Block

The String Information data block contains string data. For example, the String Information data block is used to convey the Common Vulnerabilities and Exposures (CVE) identification string within a Scan Vulnerability data block. The String Information data block has a block type of 35 in the series 1 group of blocks.

The following diagram shows the format of the String Information data block:

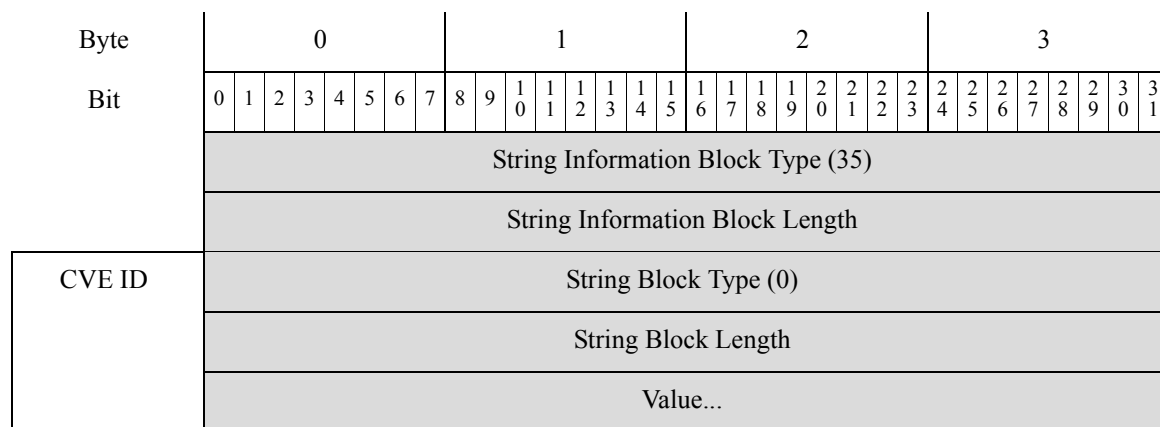

The following table describes the fields of the String Information data block.

**Table 4-38** String Information Data Block Fields

| Field                           | Data Type | Description   |
|---------------------------------|-----------|---|
| String Information Block Type   | uint32    | Initiates a String Information data block. This value is always 35.   |
| String Information Block Length | uint32    | Combined length of the String Information data block header and String Information data.  |
| String Block Type               | uint32    | Initiates a string data block for the value.  |
| String Block Length             | uint32    | Number of bytes in the string data block for the value, including eight bytes for the string block type and length, plus the number of bytes in the value.          |
| Value                           | string    | The value of the Common Vulnerabilities and Exposures (CVE) identification number for the vulnerability data block where the String Information data block is used. |

## Attribute Address Data Block 5.2+

The Attribute Address data block contains an attribute list item and is used within an Attribute Definition data block. It has a block type of 146 in the series 1 group of blocks.

The following diagram shows the basic structure of an Attribute Address data block:

|                                    |   |   |   |   |   |   |   |   |   |   |    |    |    |    |    |    |    |    |    |    |    |    |    |    |    |    |    |    |    |    |    |    |
|------------------------------------|---|---|---|---|---|---|---|---|---|---|----|----|----|----|----|----|----|----|----|----|----|----|----|----|----|----|----|----|----|----|----|----|
| Byte                               | 0 |   |   |   |   |   |   |   | 1 |   |    |    |    |    |    |    | 2  |    |    |    |    |    |    |    | 3  |    |    |    |    |    |    |    |
| Bit                                | 0 | 1 | 2 | 3 | 4 | 5 | 6 | 7 | 8 | 9 | 10 | 11 | 12 | 13 | 14 | 15 | 16 | 17 | 18 | 19 | 20 | 21 | 22 | 23 | 24 | 25 | 26 | 27 | 28 | 29 | 30 | 31 |
| Attribute Address Block Type (146) |   |   |   |   |   |   |   |   |   |   |    |    |    |    |    |    |    |    |    |    |    |    |    |    |    |    |    |    |    |    |    |    |
| Attribute Address Block Length     |   |   |   |   |   |   |   |   |   |   |    |    |    |    |    |    |    |    |    |    |    |    |    |    |    |    |    |    |    |    |    |    |
| Attribute ID                       |   |   |   |   |   |   |   |   |   |   |    |    |    |    |    |    |    |    |    |    |    |    |    |    |    |    |    |    |    |    |    |    |
| IP Address                         |   |   |   |   |   |   |   |   |   |   |    |    |    |    |    |    |    |    |    |    |    |    |    |    |    |    |    |    |    |    |    |    |
| IP Address, continued              |   |   |   |   |   |   |   |   |   |   |    |    |    |    |    |    |    |    |    |    |    |    |    |    |    |    |    |    |    |    |    |    |
| IP Address, continued              |   |   |   |   |   |   |   |   |   |   |    |    |    |    |    |    |    |    |    |    |    |    |    |    |    |    |    |    |    |    |    |    |
| IP Address, continued              |   |   |   |   |   |   |   |   |   |   |    |    |    |    |    |    |    |    |    |    |    |    |    |    |    |    |    |    |    |    |    |    |
| Bits                               |   |   |   |   |   |   |   |   |   |   |    |    |    |    |    |    |    |    |    |    |    |    |    |    |    |    |    |    |    |    |    |    |

The following table describes the fields of the Attribute Address data block.

**Table 4-39** Attribute Address Data Block 5.2+ Fields

| Field                          | Data Type | Description  |
|--------------------------------|-----------|--|
| Attribute Address Block Type   | uint32    | Initiates an Attribute Address data block. This value is always 146.   |
| Attribute Address Block Length | uint32    | Number of bytes in the Attribute Address data block, including eight bytes for the attribute address block type and length, plus the number of bytes in the attribute address data that follows. |
| Attribute ID                   | uint32    | Identification number of the affected attribute, if applicable.  |
| IP Address                     | uint8[16] | IP address of the host, if the address was automatically assigned. The address can be IPv4 or IPv6.  |
| Bits                           | uint32    | Contains the significant bits used to calculate the netmask if an IP address was automatically assigned.   |

## Attribute List Item Data Block

The Attribute List Item data block contains an attribute list item and is used within an Attribute Definition data block. It has a block type of 39 in the series 1 group of blocks.

The following diagram shows the basic structure of an Attribute List Item data block:

|           |                                     |   |   |   |   |   |   |   |   |   |    |    |    |    |    |    |    |    |    |    |    |    |    |    |    |    |    |    |    |    |    |    |
|-----------|-------------------------------------|---|---|---|---|---|---|---|---|---|----|----|----|----|----|----|----|----|----|----|----|----|----|----|----|----|----|----|----|----|----|----|
| Byte      | 0                                   |   |   |   |   |   |   |   | 1 |   |    |    |    |    |    |    | 2  |    |    |    |    |    |    |    | 3  |    |    |    |    |    |    |    |
| Bit       | 0                                   | 1 | 2 | 3 | 4 | 5 | 6 | 7 | 8 | 9 | 10 | 11 | 12 | 13 | 14 | 15 | 16 | 17 | 18 | 19 | 20 | 21 | 22 | 23 | 24 | 25 | 26 | 27 | 28 | 29 | 30 | 31 |
|           | Attribute List Item Block Type (39) |   |   |   |   |   |   |   |   |   |    |    |    |    |    |    |    |    |    |    |    |    |    |    |    |    |    |    |    |    |    |    |
|           | Attribute List Item Block Length    |   |   |   |   |   |   |   |   |   |    |    |    |    |    |    |    |    |    |    |    |    |    |    |    |    |    |    |    |    |    |    |
|           | Attribute ID                        |   |   |   |   |   |   |   |   |   |    |    |    |    |    |    |    |    |    |    |    |    |    |    |    |    |    |    |    |    |    |    |
| Attr Name | String Block Type (0)               |   |   |   |   |   |   |   |   |   |    |    |    |    |    |    |    |    |    |    |    |    |    |    |    |    |    |    |    |    |    |    |
|           | String Block Length                 |   |   |   |   |   |   |   |   |   |    |    |    |    |    |    |    |    |    |    |    |    |    |    |    |    |    |    |    |    |    |    |
|           | Name...                             |   |   |   |   |   |   |   |   |   |    |    |    |    |    |    |    |    |    |    |    |    |    |    |    |    |    |    |    |    |    |    |

The following table describes the fields of the Attribute List Item data block.

**Table 4-40** Attribute List Item Data Block Fields

| Field                            | Data Type | Description  |
|----------------------------------|-----------|--|
| Attribute List Item Block Type   | uint32    | Initiates an Attribute List Item data block. This value is always 39.  |
| Attribute List Item Block Length | uint32    | Number of bytes in the Attribute List Item data block, including eight bytes for the attribute list item block type and length, plus the number of bytes in the attribute list item data that follows. |
| Attribute ID                     | uint32    | Identification number of the affected attribute, if applicable.  |
| String Block Type                | uint32    | Initiates a String data block for the attribute list item name. This value is always 0.  |
| String Block Length              | uint32    | Number of bytes in the String data block for the attribute list item name, including eight bytes for the string block type and length, plus the number of bytes in the attribute list item name.       |
| Name                             | string    | Attribute list item name.  |

## Attribute Value Data Block

The Attribute Value data block conveys attribute identification numbers and values for host attributes. An Attribute Value data block for each attribute applied to the host in the event is included in a list in the Full Host Profile data block. The Attribute Value data block has a block type of 48 in the series 1 group of blocks.

The following diagram shows the format of the Attribute Value data block:

|      |                                 |   |   |   |   |   |   |   |   |   |    |    |    |    |    |    |    |    |    |    |    |    |    |    |    |    |    |    |    |    |    |    |
|------|---------------------------------|---|---|---|---|---|---|---|---|---|----|----|----|----|----|----|----|----|----|----|----|----|----|----|----|----|----|----|----|----|----|----|
| Byte | 0                               |   |   |   |   |   |   |   | 1 |   |    |    |    |    |    |    | 2  |    |    |    |    |    |    |    | 3  |    |    |    |    |    |    |    |
| Bit  | 0                               | 1 | 2 | 3 | 4 | 5 | 6 | 7 | 8 | 9 | 10 | 11 | 12 | 13 | 14 | 15 | 16 | 17 | 18 | 19 | 20 | 21 | 22 | 23 | 24 | 25 | 26 | 27 | 28 | 29 | 30 | 31 |
|      | Attribute Value Block Type (48) |   |   |   |   |   |   |   |   |   |    |    |    |    |    |    |    |    |    |    |    |    |    |    |    |    |    |    |    |    |    |    |
|      | Attribute Value Block Length    |   |   |   |   |   |   |   |   |   |    |    |    |    |    |    |    |    |    |    |    |    |    |    |    |    |    |    |    |    |    |    |
|      | Attribute ID                    |   |   |   |   |   |   |   |   |   |    |    |    |    |    |    |    |    |    |    |    |    |    |    |    |    |    |    |    |    |    |    |
|      | Attribute Type                  |   |   |   |   |   |   |   |   |   |    |    |    |    |    |    |    |    |    |    |    |    |    |    |    |    |    |    |    |    |    |    |
|      | Attribute Integer Value         |   |   |   |   |   |   |   |   |   |    |    |    |    |    |    |    |    |    |    |    |    |    |    |    |    |    |    |    |    |    |    |
|      | String Data Block (0)           |   |   |   |   |   |   |   |   |   |    |    |    |    |    |    |    |    |    |    |    |    |    |    |    |    |    |    |    |    |    |    |
|      | String Block Length             |   |   |   |   |   |   |   |   |   |    |    |    |    |    |    |    |    |    |    |    |    |    |    |    |    |    |    |    |    |    |    |
|      | Attribute Value String...       |   |   |   |   |   |   |   |   |   |    |    |    |    |    |    |    |    |    |    |    |    |    |    |    |    |    |    |    |    |    |    |

The following table describes the components of the Attribute Value data block.

**Table 4-41** Attribute Value Data Block Fields

| Field                        | Data Type | Description   |
|------------------------------|-----------|---|
| Attribute Value Block Type   | uint32    | Initiates an Attribute Value data block. This value is always 48.   |
| Attribute Value Block Length | uint32    | Total number of bytes in the Attribute Value data block, including eight bytes for the attribute value block type and length fields, plus the number of bytes of attribute block data that follows.   |
| Attribute ID                 | uint32    | The identification number for the attribute.  |
| Attribute Type               | uint32    | Type of affected attribute. Possible values are: <ul style="list-style-type: none"> <li>0 - attribute with text as value; this uses string data</li> <li>1 - attribute with value in range; this uses integer data</li> <li>2 - attribute with a list of possible values, this uses integer data</li> <li>3 - attribute with a URL as value; this uses string data</li> <li>4 - attribute with binary BLOB as value; this uses string data</li> </ul> |
| Attribute Integer Value      | uint32    | Integer value for the attribute, if applicable.   |
| String Block Type            | uint32    | Initiates a String data block containing the attribute name. This value is always 0.  |
| String Block Length          | uint32    | Number of bytes in the String data block, including the string block type and length fields, plus the number of bytes in the attribute name.  |
| Attribute Value              | string    | Value of the attribute.   |



## Full Sub-Server Data Block

The Full Sub-Server data block conveys information about a sub-server associated with a server detected on a host, and includes information about the sub-server such as its vendor and version and any related VDB and third-party vulnerabilities for the sub-server on the host. A sub-server is a loadable module of a server that has its own associated vulnerabilities. A Full Host Server data block includes a Full Sub-Server data block for each sub-server detected on the host. The Full Sub-Server data block has a block type of 51 in the series 1 group of blocks.



### Note

An asterisk (\*) next to a series 1 data block name in the following diagram indicates that multiple instances of the data block may occur.

The following diagram shows the format of the Full Sub-Server data block:

| Byte | 0  |   |   |   |   |   |   |   | 1 |   |    |    |    |    |    |    | 2  |    |    |    |    |    |    |    | 3  |    |    |    |    |    |    |    |
|------|--|---|---|---|---|---|---|---|---|---|----|----|----|----|----|----|----|----|----|----|----|----|----|----|----|----|----|----|----|----|----|----|
| Bit  | 0  | 1 | 2 | 3 | 4 | 5 | 6 | 7 | 8 | 9 | 10 | 11 | 12 | 13 | 14 | 15 | 16 | 17 | 18 | 19 | 20 | 21 | 22 | 23 | 24 | 25 | 26 | 27 | 28 | 29 | 30 | 31 |
|      | Full Sub-Server Block Type (51)                    |   |   |   |   |   |   |   |   |   |    |    |    |    |    |    |    |    |    |    |    |    |    |    |    |    |    |    |    |    |    |    |
|      | Full Sub-Server Block Length                       |   |   |   |   |   |   |   |   |   |    |    |    |    |    |    |    |    |    |    |    |    |    |    |    |    |    |    |    |    |    |    |
|      | String Block Type (0)                              |   |   |   |   |   |   |   |   |   |    |    |    |    |    |    |    |    |    |    |    |    |    |    |    |    |    |    |    |    |    |    |
|      | String Block Length                                |   |   |   |   |   |   |   |   |   |    |    |    |    |    |    |    |    |    |    |    |    |    |    |    |    |    |    |    |    |    |    |
|      | Sub-Server Name String...                          |   |   |   |   |   |   |   |   |   |    |    |    |    |    |    |    |    |    |    |    |    |    |    |    |    |    |    |    |    |    |    |
|      | String Block Type (0)                              |   |   |   |   |   |   |   |   |   |    |    |    |    |    |    |    |    |    |    |    |    |    |    |    |    |    |    |    |    |    |    |
|      | String Block Length                                |   |   |   |   |   |   |   |   |   |    |    |    |    |    |    |    |    |    |    |    |    |    |    |    |    |    |    |    |    |    |    |
|      | Sub-Server Vendor Name String...                   |   |   |   |   |   |   |   |   |   |    |    |    |    |    |    |    |    |    |    |    |    |    |    |    |    |    |    |    |    |    |    |
|      | String Block Type (0)                              |   |   |   |   |   |   |   |   |   |    |    |    |    |    |    |    |    |    |    |    |    |    |    |    |    |    |    |    |    |    |    |
|      | String Block Length                                |   |   |   |   |   |   |   |   |   |    |    |    |    |    |    |    |    |    |    |    |    |    |    |    |    |    |    |    |    |    |    |
|      | Sub-Server Version String...                       |   |   |   |   |   |   |   |   |   |    |    |    |    |    |    |    |    |    |    |    |    |    |    |    |    |    |    |    |    |    |    |
|      | Generic List Block Type (31)                       |   |   |   |   |   |   |   |   |   |    |    |    |    |    |    |    |    |    |    |    |    |    |    |    |    |    |    |    |    |    |    |
|      | Generic List Block Length                          |   |   |   |   |   |   |   |   |   |    |    |    |    |    |    |    |    |    |    |    |    |    |    |    |    |    |    |    |    |    |    |
|      | (VDB) Host Vulnerability Data Blocks*              |   |   |   |   |   |   |   |   |   |    |    |    |    |    |    |    |    |    |    |    |    |    |    |    |    |    |    |    |    |    |    |
|      | Generic List Block Type (31)                       |   |   |   |   |   |   |   |   |   |    |    |    |    |    |    |    |    |    |    |    |    |    |    |    |    |    |    |    |    |    |    |
|      | Generic List Block Length                          |   |   |   |   |   |   |   |   |   |    |    |    |    |    |    |    |    |    |    |    |    |    |    |    |    |    |    |    |    |    |    |
|      | (Third-Party Scan) Host Vulnerability Data Blocks* |   |   |   |   |   |   |   |   |   |    |    |    |    |    |    |    |    |    |    |    |    |    |    |    |    |    |    |    |    |    |    |

The following table describes the components of the Full Sub-Server data block.

**Table 4-42 Full Sub-Server Data Block Fields**

| Field   | Data Type | Description  |
|---|-----------|--|
| Full Sub-Server Block Type                        | uint32    | Initiates a Full Sub-Server data block. This value is always 51.   |
| Full Sub-Server Block Length                      | uint32    | Total number of bytes in the Full Sub-Server data block, including eight bytes for the Full Sub-Server block type and length fields, plus the number of bytes in the full sub-server data that follows.  |
| String Block Type                                 | uint32    | Initiates a String data block containing the sub-server name. This value is always 0.  |
| String Block Length                               | uint32    | Number of bytes in the sub-server name String data block, including eight bytes for the block type and length fields, plus the number of bytes in the sub-server name.   |
| Sub-Server Name                                   | string    | Sub-server name.   |
| String Block Type                                 | uint32    | Initiates a String data block containing the sub-server vendor's name. This value is always 0.   |
| String Block Length                               | uint32    | Number of bytes in the vendor name String data block, including eight bytes for the block type and length fields, plus the number of bytes in the sub-server vendor name.  |
| Sub-Server Vendor Name                            | string    | Name of the sub-server vendor.   |
| String Block Type                                 | uint32    | Initiates a String data block that contains the sub-server version. This value is always 0.  |
| String Block Length                               | uint32    | Number of bytes in the sub-server version String data block, including eight bytes for the block type and length fields, plus the number of bytes in the sub-server version.   |
| Sub-Server Version                                | string    | Sub-server version.  |
| Generic List Block Type                           | uint32    | Initiates a Generic List data block comprising Host Vulnerability data blocks conveying VDB Vulnerability data. This value is always 31.   |
| Generic List Block Length                         | uint32    | Number of bytes in the Generic List data block, including the list header and all encapsulated Host Vulnerability data blocks.   |
| VDB Host Vulnerability Data Blocks *              | variable  | Host Vulnerability data blocks containing information about host vulnerabilities identified by Cisco. See <a href="#">Host Vulnerability Data Block 4.9.0+, page 4-105</a> for a description of this data block.                               |
| Generic List Block Type                           | uint32    | Initiates a Generic List data block comprising Host Vulnerability data blocks conveying Third-Party Scan Vulnerability data. This value is always 31.  |
| Generic List Block Length                         | uint32    | Number of bytes in the Generic List data block, including the list header and all encapsulated Host Vulnerability data blocks.   |
| Third-Party Scan Host Vulnerability Data Blocks * | variable  | Host Vulnerability data blocks containing information about host vulnerabilities identified by a third-party vulnerability scanner. See <a href="#">Host Vulnerability Data Block 4.9.0+, page 4-105</a> for a description of this data block. |

## Operating System Data Block 3.5+

The operating system data block for Version 3.5+ has a block type of 53 in the series 1 group of blocks. The block includes a fingerprint Universally Unique Identifier (UUID). The following diagram shows the format of an operating system data block in 3.5+.

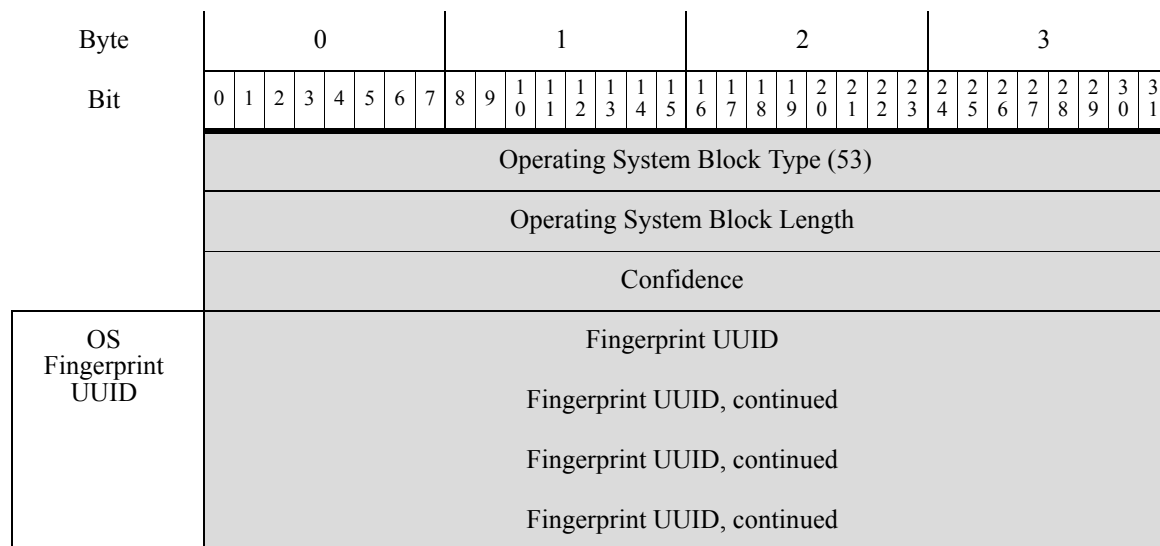

The following table describes the fields of the v3.5 operating system data block.

**Table 4-43** Operating System Data Block 3.5+ Fields

| Field                              | Data Type | Description   |
|------------------------------------|-----------|---|
| Operating System Data Block Type   | uint32    | Initiates the operating system data block. This value is always 53.   |
| Operating System Data Block Length | uint32    | Number of bytes in the Operating System data block. This value should always be 28: eight bytes for the data block type and length fields, plus four bytes for the confidence value and sixteen bytes for the fingerprint UUID value. |
| Confidence                         | uint32    | Confidence percentage value.  |
| Fingerprint UUID                   | uint8[16] | Fingerprint identification number, in octets, that acts as a unique identifier for the operating system. The fingerprint UUID maps to the operating system name, vendor, and version in the Cisco database.                           |

## Policy Engine Control Message Data Block

The Policy Engine Control Message data block conveys the control message content for policy types. The Policy Engine Control Message data block has a block type of 54 in the series 1 group of blocks.

The following diagram shows the format of the Policy Engine Control Message data block:

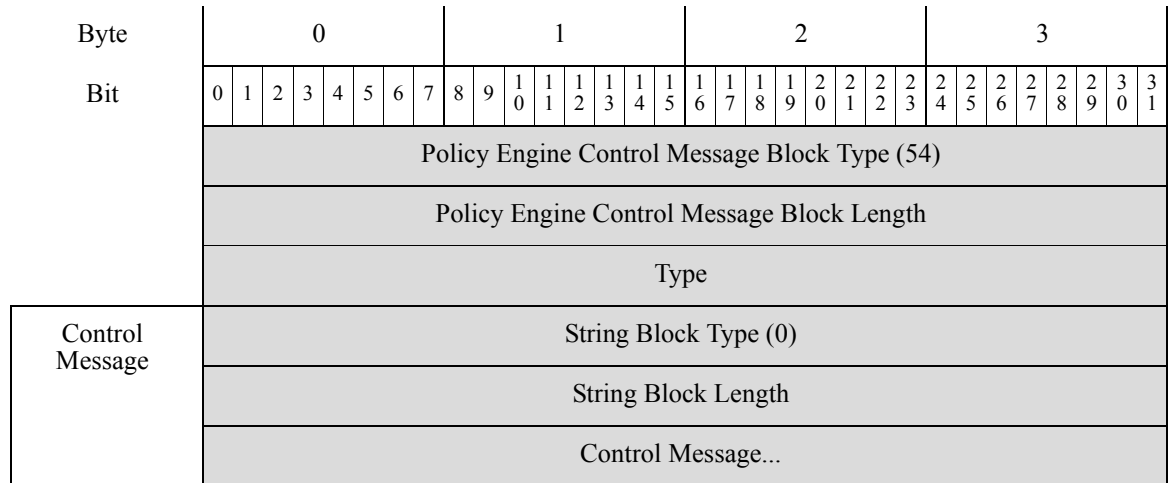

The following table describes the components of the Policy Engine Control Message data block.

**Table 4-44** Policy Engine Control Message Data Block Fields

| Field                                    | Data Type | Description   |
|--|-----------|---|
| Policy Engine Control Message Block Type | uint32    | Initiates a Policy Engine Control Message data block. This value is always 54.  |
| Policy Engine Control Message Length     | uint32    | Total number of bytes in the Policy Engine Control Message data block, including eight bytes for the policy engine control block type and length fields, plus the number of bytes of policy engine control data that follows. |
| Type                                     | uint32    | Indicates the type of policy for the event.   |
| String Block Type                        | uint32    | Initiates a String data block that contains the control message. This value is always 0.  |
| String Block Length                      | uint32    | Number of bytes in the control message String data block, including eight bytes for the block type and length fields, plus the number of bytes in the control message.  |
| Control Message                          | uint32    | The control message from the policy engine.   |

## Attribute Definition Data Block for 4.7+

The Attribute Definition data block contains the attribute definition in an attribute creation, change, or deletion event and is used within Host Attribute Add events (event type 1002, subtype 6), Host Attribute Update events (event type 1002, subtype 7), and Host Attribute Delete events (event type 1002, subtype 8). It has a block type of 55 in the series 1 group of blocks.

For more information on those events, see [Attribute Messages, page 4-50](#).

The following diagram shows the basic structure of an Attribute Definition data block:

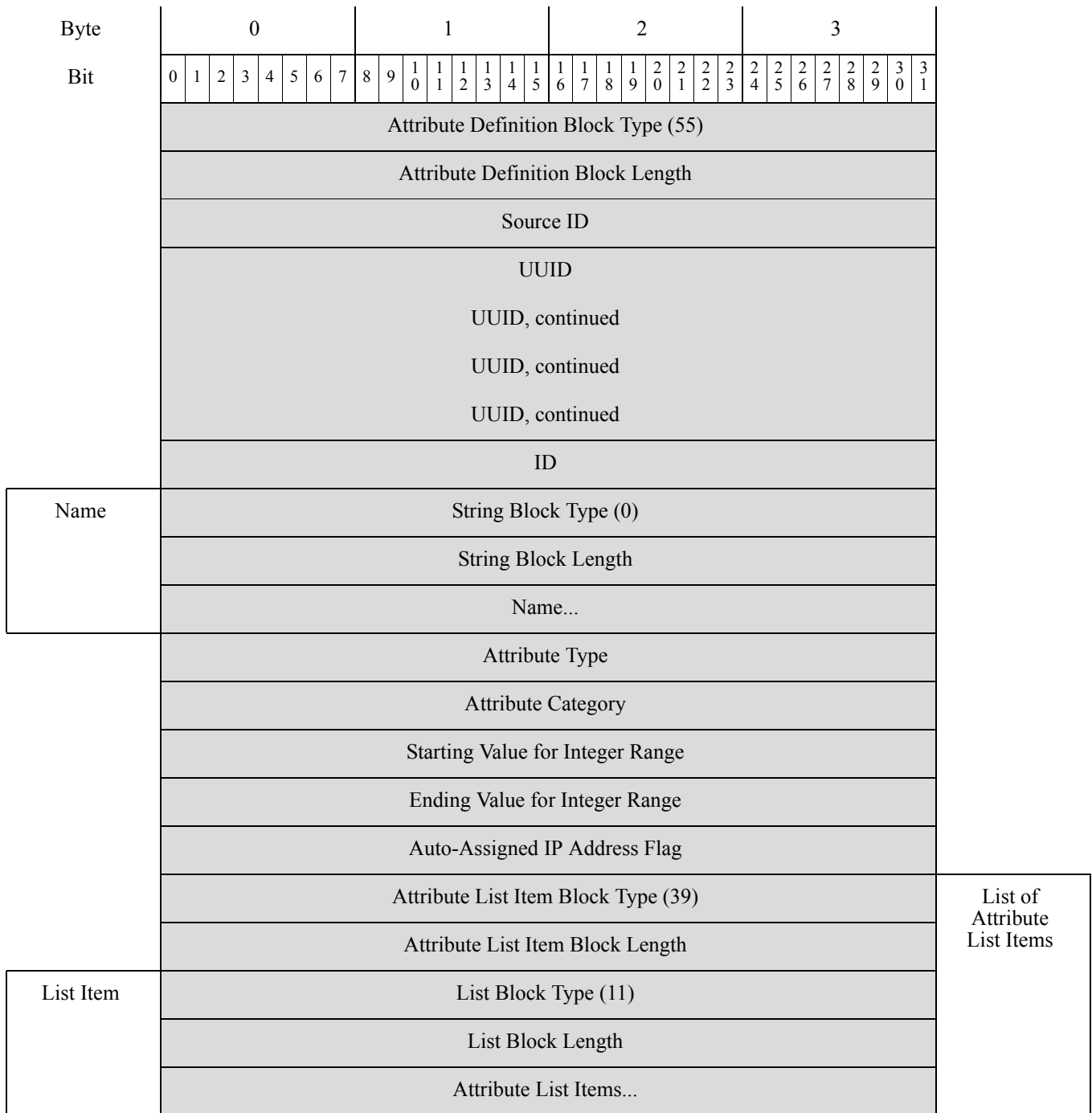

|              |                                   |   |   |   |   |   |   |   |   |   |    |    |    |    |    |    |    |    |    |    |    |    |    |    |    |    |    |    |    |    |    |    |                             |
|--------------|-----------------------------------|---|---|---|---|---|---|---|---|---|----|----|----|----|----|----|----|----|----|----|----|----|----|----|----|----|----|----|----|----|----|----|-----------------------------|
| Byte         | 0                                 |   |   |   |   |   |   |   | 1 |   |    |    |    |    |    |    | 2  |    |    |    |    |    |    |    | 3  |    |    |    |    |    |    |    |                             |
| Bit          | 0                                 | 1 | 2 | 3 | 4 | 5 | 6 | 7 | 8 | 9 | 10 | 11 | 12 | 13 | 14 | 15 | 16 | 17 | 18 | 19 | 20 | 21 | 22 | 23 | 24 | 25 | 26 | 27 | 28 | 29 | 30 | 31 |                             |
|              | Attribute Address Block Type (38) |   |   |   |   |   |   |   |   |   |    |    |    |    |    |    |    |    |    |    |    |    |    |    |    |    |    |    |    |    |    |    | List of Attribute Addresses |
|              | Attribute Address Block Length    |   |   |   |   |   |   |   |   |   |    |    |    |    |    |    |    |    |    |    |    |    |    |    |    |    |    |    |    |    |    |    |                             |
| Address List | List Block Type (11)              |   |   |   |   |   |   |   |   |   |    |    |    |    |    |    |    |    |    |    |    |    |    |    |    |    |    |    |    |    |    |    |                             |
|              | List Block Length                 |   |   |   |   |   |   |   |   |   |    |    |    |    |    |    |    |    |    |    |    |    |    |    |    |    |    |    |    |    |    |    |                             |
|              | Attribute Address List...         |   |   |   |   |   |   |   |   |   |    |    |    |    |    |    |    |    |    |    |    |    |    |    |    |    |    |    |    |    |    |    |                             |

The following table describes the fields of the Attribute Definition data block.

**Table 4-45** Attribute Definition Data Block Fields

| Field                             | Data Type | Description  |
|-----------------------------------|-----------|--|
| Attribute Definition Block Type   | uint32    | Initiates an Attribute Definition data block. This value is always 55.   |
| Attribute Definition Block Length | uint32    | Number of bytes in the Attribute Definition data block, including eight bytes for the attribute definition block type and length, plus the number of bytes in the attribute definition data that follows.  |
| Source ID                         | uint32    | Identification number that maps to the source of the attribute data. Depending on the source type, this may map to RNA, a user, a scanner, or a third-party application.   |
| UUID                              | uint8[16] | An ID number that acts as a unique identifier for the affected attribute.  |
| Attribute ID                      | uint32    | Identification number of the affected attribute, if applicable.  |
| String Block Type                 | uint32    | Initiates a String data block for the attribute definition name. This value is always 0.   |
| String Block Length               | uint32    | Number of bytes in the String data block for the attribute definition name, including eight bytes for the string block type and length, plus the number of bytes in the attribute definition name.   |
| Name                              | string    | Attribute definition name.   |
| Attribute Type                    | uint32    | Type of attribute. Possible values are: <ul style="list-style-type: none"> <li>0 - attribute with text as value; this uses string data</li> <li>1 - attribute with value in range; this uses integer data</li> <li>2 - attribute with a list of possible values; this uses integer data</li> <li>3 - attribute with a URL as value; this uses string data</li> <li>4 - attribute with binary BLOB as value; this uses string data</li> </ul> |
| Attribute Category                | uint32    | Attribute category.  |
| Starting Value for Range          | uint32    | First integer in the integer range for the defined attribute.  |

Table 4-45 Attribute Definition Data Block Fields (continued)

| Field                            | Data Type | Description   |
|----------------------------------|-----------|---|
| Ending Value for Range           | uint32    | Last integer in the integer range for the defined attribute.  |
| Auto-Assigned IP Address Flag    | uint32    | Flag indicating if an IP address is auto-assigned based on the attribute.   |
| List Block Type                  | uint32    | Initiates a List data block comprising Attribute List Item data blocks conveying attribute list items. This value is always 11.   |
| List Block Length                | uint32    | Number of bytes in the list. This number includes the eight bytes of the list block type and length fields, plus all encapsulated Attribute List Item data blocks.<br><br>This field is followed by zero or more Attribute List Item data blocks. |
| Attribute List Item Block Type   | uint32    | Initiates the first Attribute List Item data block. This data block can be followed by other Attribute List Item data blocks up to the limit defined in the list block length field.  |
| Attribute List Item Block Length | uint32    | Number of bytes in the Attribute List Item String data block, including eight bytes for the block type and header fields, plus the number of bytes in the attribute list item.  |
| Attribute List Item              | variable  | Attribute List Item data as documented in <a href="#">Attribute List Item Data Block, page 4-74</a> .   |
| List Block Type                  | uint32    | Initiates a List data block comprising Attribute Address data blocks conveying IP addresses for hosts with the attribute. This value is always 11.  |
| List Block Length                | uint32    | Number of bytes in the list. This number includes the eight bytes of the list block type and length fields, plus all encapsulated Attribute Address data blocks.<br><br>This field is followed by zero or more Attribute Address data blocks.     |
| Attribute Address Block Type     | uint32    | Initiates the first Attribute Address data block. This data block can be followed by other Attribute Address data blocks up to the limit defined in the list block length field.  |
| Attribute Address Block Length   | uint32    | Number of bytes in the Attribute Address data block, including eight bytes for the block type and header fields, plus the number of bytes in the attribute address.   |
| Attribute Address                | variable  | Attribute Address data as documented in <a href="#">Attribute Address Data Block 5.2+, page 4-73</a> .  |

## User Protocol Data Block

The User Protocol data block is used to contain information about added protocols, the type of the protocol, and lists of IP address and MAC address ranges for the hosts with the protocol. The User Protocol data block has a block type of 57 in the series 1 group of blocks.

The following diagram shows the basic structure of a User Protocol data block:

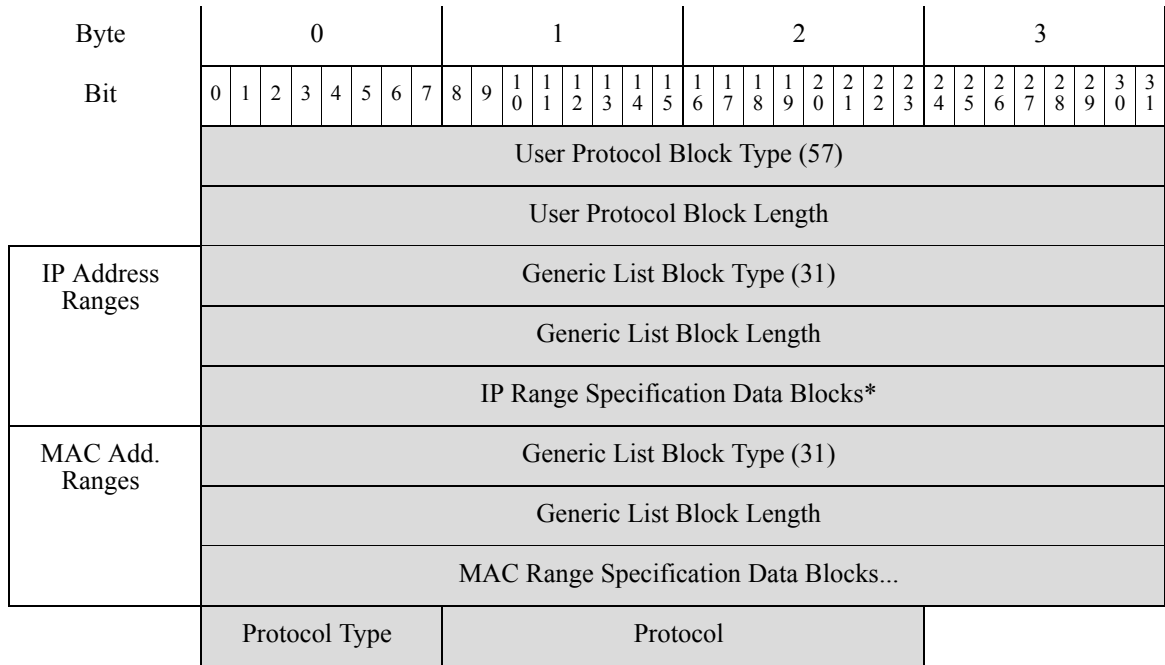

The following table describes the fields of the User Protocol data block.

Table 4-46 User Protocol Data Block Fields

| Field                                | Number of Bytes | Description   |
|--------------------------------------|-----------------|---|
| User Protocol Block Type             | uint32          | Initiates a User Protocol data block. This value is always 57.  |
| User Protocol Block Length           | uint32          | Total number of bytes in the User Protocol data block, including eight bytes for the user protocol block type and length fields, plus the number of bytes of user protocol data that follows.                       |
| Generic List Block Type              | uint32          | Initiates a Generic List data block comprising IP Range Specification data blocks conveying IP address range data. This value is always 31.   |
| Generic List Block Length            | uint32          | Number of bytes in the Generic List data block, including the list header and all encapsulated IP Range Specification data blocks.  |
| IP Range Specification Data Blocks * | variable        | IP Range Specification data blocks containing information about the IP address ranges for the user input. See <a href="#">IP Address Range Data Block for 5.2+, page 4-88</a> for a description of this data block. |
| Generic List Block Type              | uint32          | Initiates a Generic List data block comprising MAC Range Specification data blocks conveying MAC address range data. This value is always 31.   |
| Generic List Block Length            | uint32          | Number of bytes in the Generic List data block, including the list header and all encapsulated MAC Range Specification data blocks.   |



Table 4-46 User Protocol Data Block Fields (continued)

| Field                                 | Number of Bytes | Description   |
|---------------------------------------|-----------------|---|
| MAC Range Specification Data Blocks * | variable        | MAC Range Specification data blocks containing information about the MAC address ranges for the user input. See <a href="#">MAC Address Specification Data Block, page 4-91</a> for a description of this data block. |
| Protocol Type                         | uint8           | Indicates the type of the protocol. The protocol can be either 0, for a network layer protocol such as IP, or 1 for a transport layer protocol such as TCP or UDP.  |
| Protocol                              | uint16          | Indicates the protocol for the data contained in the data block.  |

## User Client Application Data Block for 5.1.1+

The User Client Application data block contains information about the source of the client application data, the identification number for the user who added the data, and the lists of IP address range data blocks. The payload ID, which was added in Version 5.3.1, specifies the application instance associated with the record. The User Client Application data block has a block type of 138 in the series 1 group of blocks. It replaces block type 59.

The following diagram shows the basic structure of a User Client Application data block:

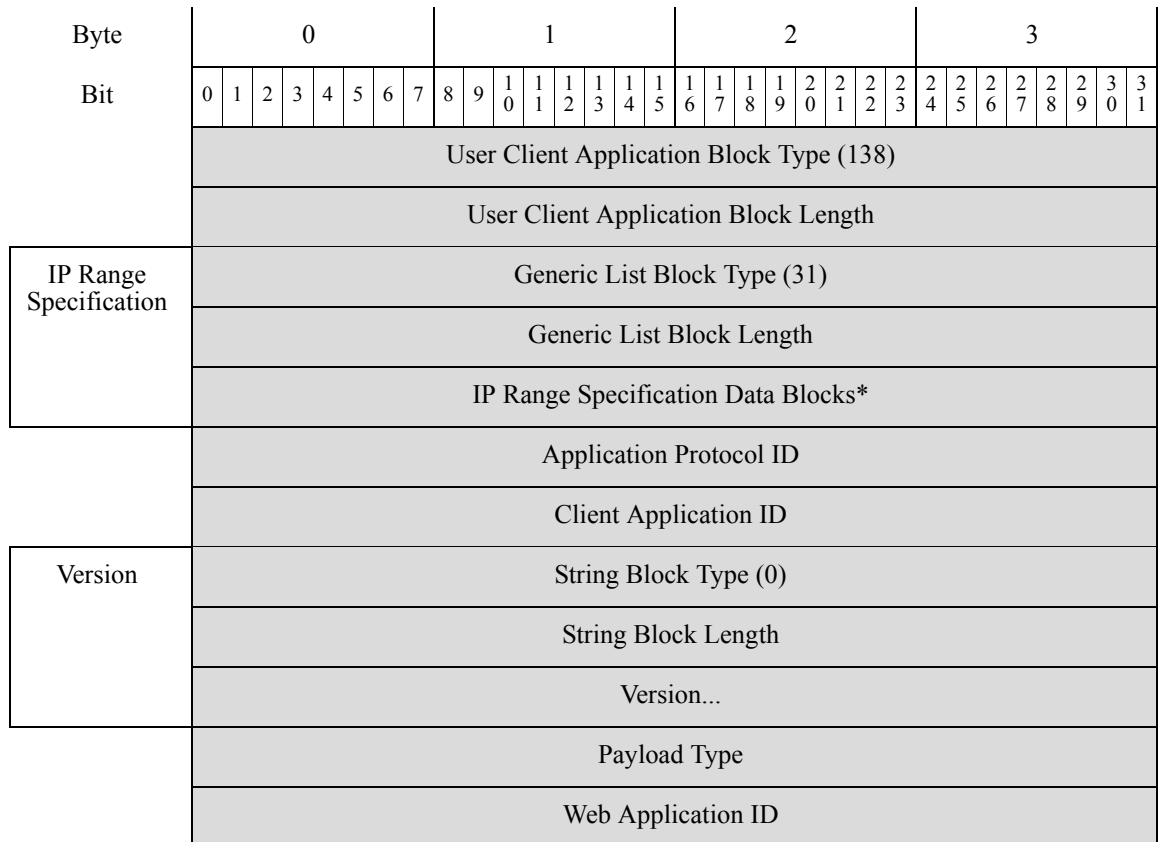

The following table describes the fields of the User Client Application data block.

**Table 4-47** User Client Application Data Block Fields

| Field                                | Number of Bytes | Description   |
|--------------------------------------|-----------------|---|
| User Client Application Block Type   | uint32          | Initiates a User Client Application data block. This value is always 138.   |
| User Client Application Block Length | uint32          | Total number of bytes in the User Client Application data block, including eight bytes for the user client application block type and length fields, plus the number of bytes of user client application data that follows. |
| Generic List Block Type              | uint32          | Initiates a Generic List data block comprising IP Range Specification data blocks conveying IP address range data. This value is always 31.   |
| Generic List Block Length            | uint32          | Number of bytes in the Generic List data block, including the list header and all encapsulated IP Range Specification data blocks.  |
| IP Range Specification Data Blocks * | variable        | IP Range Specification data blocks containing information about the IP address ranges for the user input. See <a href="#">IP Address Range Data Block for 5.2+, page 4-88</a> for a description of this data block.         |
| Application Protocol ID              | uint32          | The internal identification number for the application protocol, if applicable.   |
| Client Application ID                | uint32          | The internal identification number of the detected client application, if applicable.   |
| String Block Type                    | uint32          | Initiates a String data block that contains the client application version. This value is always 0.   |
| String Block Length                  | uint32          | Number of bytes in the client application version String data block, including the string block type and length fields, plus the number of bytes in the version.  |
| Version                              | string          | Client application version.   |
| Payload Type                         | uint32          | This field is included for backwards compatibility. It is always 0.   |
| Web Application ID                   | uint32          | The internal identification number for the web application, if applicable.  |

## User Client Application List Data Block

The User Client Application List data block contains information about the source of the client application data, the identification number for the user who added the data, and the lists of client application blocks. The User Client Application List data block has a block type of 60 in the series 1 group of blocks.

The following diagram shows the basic structure of a User Client Application List data block:

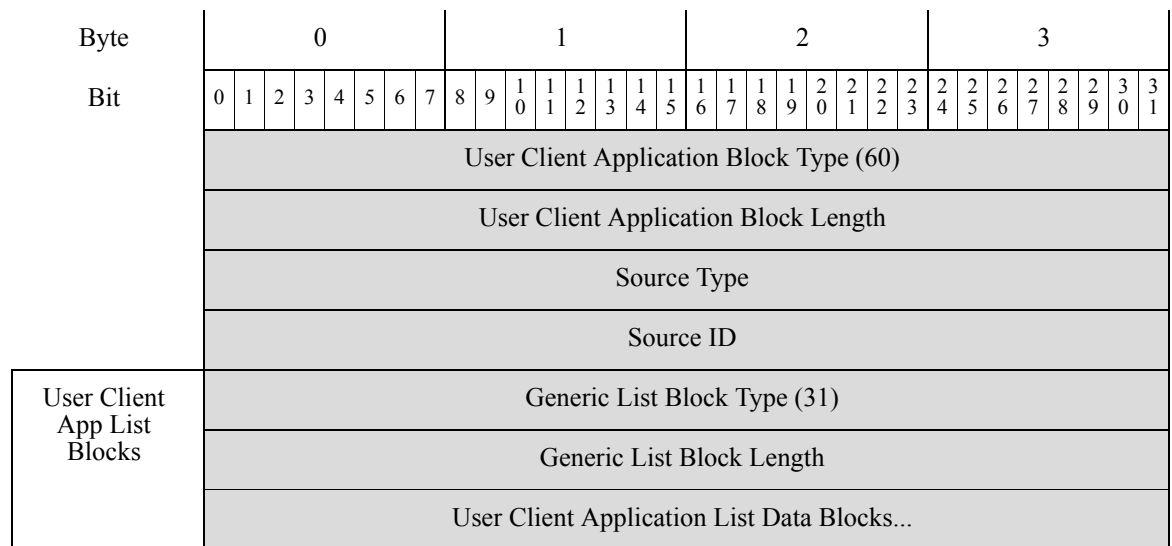

The following table describes the fields of the User Client Application List data block.

**Table 4-48** User Client Application List Data Block Fields

| Field                                     | Number of Bytes | Description  |
|---|-----------------|--|
| User Client Application List Block Type   | uint32          | Initiates a User Client Application List data block. This value is always 60.  |
| User Client Application List Block Length | uint32          | Total number of bytes in the User Client Application List data block, including eight bytes for the user client application list block type and length fields, plus the number of bytes of user client application list data that follows.   |
| Source Type                               | uint32          | Number that maps to the type of data source: <ul style="list-style-type: none"> <li>0 if the client data was detected by RNA</li> <li>1 if the client data was provided by a user</li> <li>2 if the client data was detected by a third-party scanner</li> <li>3 if the client data was provided by a command line tool such as <code>nmimport.pl</code> or the Host Input API client</li> </ul> |
| Source ID                                 | uint32          | Identification number that maps to the source that added the affected client application. Depending on the source type, this may map to RNA, a user, a scanner, or a third-party application.  |
| Generic List Block Type                   | uint32          | Initiates a Generic List data block. This value is always 31.  |

Table 4-48 User Client Application List Data Block Fields (continued)

| Field                          | Number of Bytes | Description   |
|--------------------------------|-----------------|---|
| Generic List Block Length      | uint32          | Number of bytes in the Generic List block and encapsulated data blocks. This number includes the eight bytes of the generic list block header fields, plus the number of bytes in all of the encapsulated data blocks.                                      |
| User Client Application Blocks | variable        | Encapsulated User Client Application data blocks up to the maximum number of bytes in the list block length. For more information on the User Client Application data block, see <a href="#">User Client Application Data Block for 5.1.1+</a> , page 4-85. |

## IP Address Range Data Block for 5.2+

The IP Address Range data block for 5.2+ conveys a range of IP addresses. IP Address Range data blocks are used in User Protocol, User Client Application, Address Specification, User Product, User Server, User Hosts, User Vulnerability, User Criticality, and User Attribute Value data blocks. The IP Address Range data block has a block type of 141 in the series 1 group of blocks.

The following diagram shows the format of the IP Address Range data block:

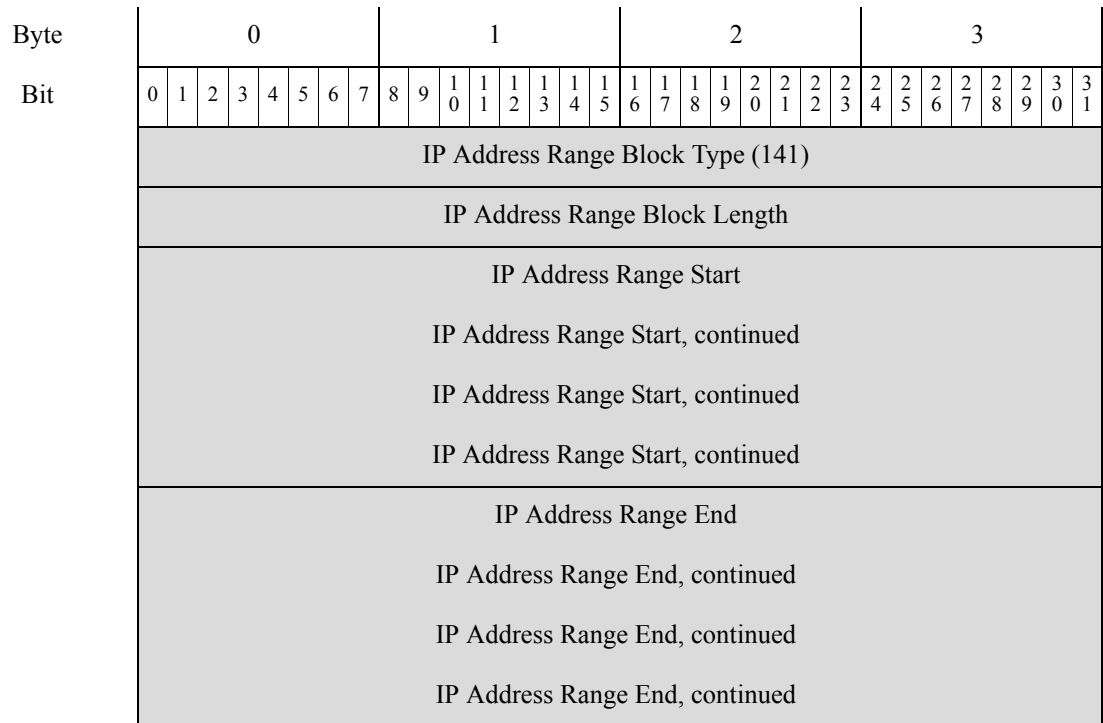

The following table describes the components of the IP Address Range Specification data block.

*Table 4-49 IP Address Range Data Block Fields*

| Field                         | Data Type | Description  |
|-------------------------------|-----------|--|
| IP Address Range Block Type   | uint32    | Initiates a IP Address Range data block. This value is always 61.  |
| IP Address Range Block Length | uint32    | Total number of bytes in the IP Address Range data block, including eight bytes for the IP Address Range block type and length fields, plus the number of bytes of IP Address Range data that follows. |
| IP Address Range Start        | uint8[16] | The starting IP address for the IP address range.  |
| IP Address Range End          | uint8[16] | The ending IP address for the IP address range.  |

## Attribute Specification Data Block

The Attribute Specification data block conveys the attribute name and value. The Attribute Specification data block has a block type of 62 in the series 1 group of blocks.

The following diagram shows the format of the Attribute Specification data block:

| Byte            | 0                                       |   |   |   |   |   |   |   | 1 |   |    |    |    |    |    |    | 2  |    |    |    |    |    |    |    | 3  |    |    |    |    |    |    |    |
|-----------------|---|---|---|---|---|---|---|---|---|---|----|----|----|----|----|----|----|----|----|----|----|----|----|----|----|----|----|----|----|----|----|----|
| Bit             | 0                                       | 1 | 2 | 3 | 4 | 5 | 6 | 7 | 8 | 9 | 10 | 11 | 12 | 13 | 14 | 15 | 16 | 17 | 18 | 19 | 20 | 21 | 22 | 23 | 24 | 25 | 26 | 27 | 28 | 29 | 30 | 31 |
|                 | Attribute Specification Block Type (62) |   |   |   |   |   |   |   |   |   |    |    |    |    |    |    |    |    |    |    |    |    |    |    |    |    |    |    |    |    |    |    |
| Attribute Name  | String Block Type (0)                   |   |   |   |   |   |   |   |   |   |    |    |    |    |    |    |    |    |    |    |    |    |    |    |    |    |    |    |    |    |    |    |
|                 | String Block Length                     |   |   |   |   |   |   |   |   |   |    |    |    |    |    |    |    |    |    |    |    |    |    |    |    |    |    |    |    |    |    |    |
|                 | Attribute Name...                       |   |   |   |   |   |   |   |   |   |    |    |    |    |    |    |    |    |    |    |    |    |    |    |    |    |    |    |    |    |    |    |
| Attribute Value | String Block Type (0)                   |   |   |   |   |   |   |   |   |   |    |    |    |    |    |    |    |    |    |    |    |    |    |    |    |    |    |    |    |    |    |    |
|                 | String Block Length                     |   |   |   |   |   |   |   |   |   |    |    |    |    |    |    |    |    |    |    |    |    |    |    |    |    |    |    |    |    |    |    |
|                 | Attribute Value...                      |   |   |   |   |   |   |   |   |   |    |    |    |    |    |    |    |    |    |    |    |    |    |    |    |    |    |    |    |    |    |    |

The following table describes the components of the Attribute Specification data block.

**Table 4-50** *Attribute Specification Data Block Fields*

| Field                              | Data Type | Description  |
|------------------------------------|-----------|--|
| Attribute Specification Block Type | uint32    | Initiates an Attribute Specification data block. This value is always 62.  |
| String Block Type                  | uint32    | Initiates a String data block that contains the attribute name. This value is always 0.  |
| String Block Length                | uint32    | Number of bytes in the attribute name String data block, including eight bytes for the block type and length fields, plus the number of bytes in the attribute name. |
| Attribute Value                    | uint32    | The value of the attribute.  |
| String Block Type                  | uint32    | Initiates a String data block that contains the attribute name. This value is always 0.  |
| String Block Length                | uint32    | Number of bytes in the attribute name String data block, including eight bytes for the block type and length fields, plus the number of bytes in the attribute name. |
| Attribute Name                     | uint32    | The name of the attribute.   |

## Host IP Address Data Block

The Host IP Address data block conveys an individual IP address. The IP address may be either an IPv4 or IPv6 address. Host IP Address data blocks are used in User Protocol, Address Specification, and User Host data blocks. The Host IP data block has a block type of 143 in the series 1 group of blocks.

The following diagram shows the format of the Host IP Address data block:

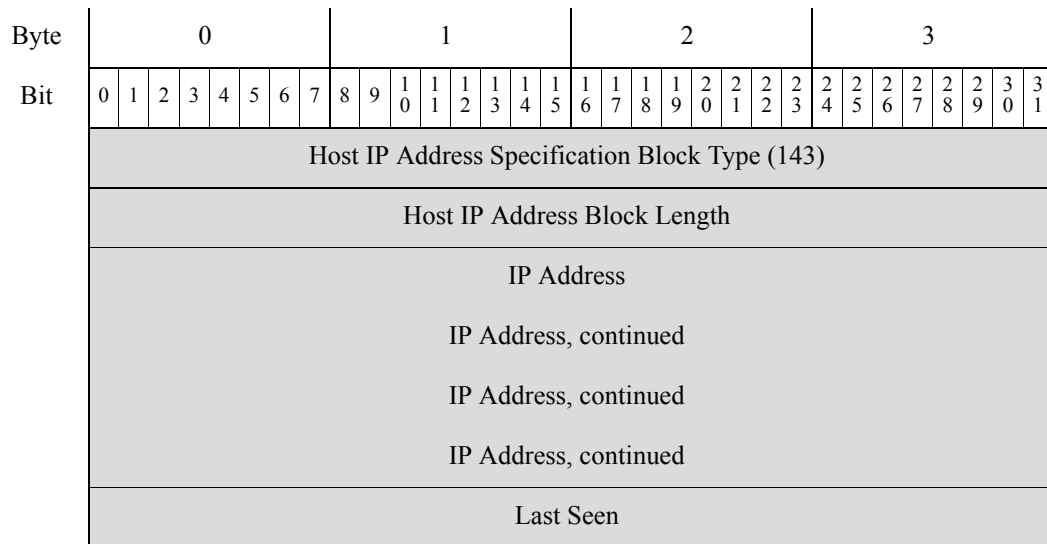

The following table describes the components of the Host IP Address data block.

*Table 4-51 Host IP Address Data Block Fields*

| Field                      | Data Type | Description   |
|----------------------------|-----------|---|
| Host IP Address Block Type | uint32    | Initiates a Host IP Address data block. This value is always 143.   |
| Host IP Block Length       | uint32    | Total number of bytes in the Host IP Address data block, including eight bytes for the Host IP block type and length fields, plus the number of bytes of Host IP Address data that follows. |
| IP Address                 | uint8[16] | The IP address. This can be IPv4 or IPv6.   |
| Last Seen                  | uint32    | UNIX timestamp that represents the last time the IP address was detected.   |

## MAC Address Specification Data Block

The MAC Address Specification data block conveys an individual MAC address. MAC Address Specification data blocks are used in User Protocol, Address Specification, and User Hosts data blocks. The MAC Address Specification data block has a block type of 63 in the series 1 group of blocks.

The following diagram shows the format of the MAC Address Specification data block:

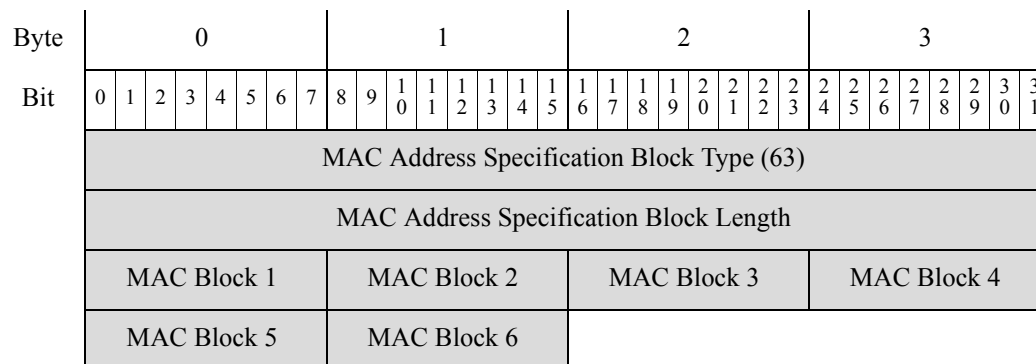

The following table describes the components of the MAC Address Specification data block.

*Table 4-52 MAC Address Specification Data Block Fields*

| Field                                  | Data Type | Description   |
|--|-----------|---|
| MAC Address Specification Block Type   | uint32    | Initiates a MAC Address Specification data block. This value is always 63.  |
| MAC Address Specification Block Length | uint32    | Total number of bytes in the MAC Address Specification data block, including eight bytes for the MAC Address Specification block type and length fields, plus the number of bytes of MAC address specification data that follows. |
| MAC Address Blocks 1 - 6               | uint8     | The blocks of the MAC address in sequential order.  |

## Address Specification Data Block

The Address Specification data block is used to contain lists of IP address range specifications and MAC address specifications. The Address Specification data block has a block type of 64 in the series 1 group of blocks.

The following diagram shows the basic structure of an Address Specification data block:

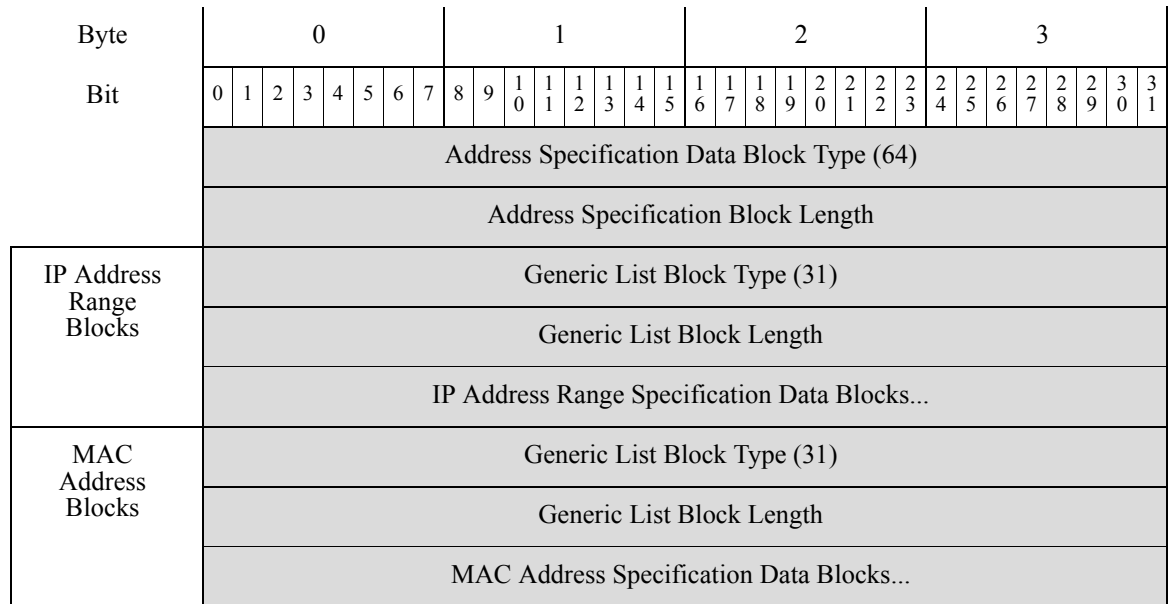

The following table describes the fields of the Address Specification data block.

**Table 4-53** Address Specification Data Block Fields

| Field                                 | Number of Bytes | Description  |
|---------------------------------------|-----------------|--|
| Address Specification Data Block Type | uint32          | Initiates an Address Specification data block. This value is always 64.  |
| Address Specification Block Length    | uint32          | Total number of bytes in the Address Specification data block, including eight bytes for the address specification block type and length fields, plus the number of bytes of address specification data that follows.  |
| Generic List Block Type               | uint32          | Initiates a Generic List data block. This value is always 31.  |
| Generic List Block Length             | uint32          | Number of bytes in the Generic List block and encapsulated data blocks. This number includes the eight bytes of the generic list block header fields, plus the number of bytes in all of the encapsulated data blocks. |

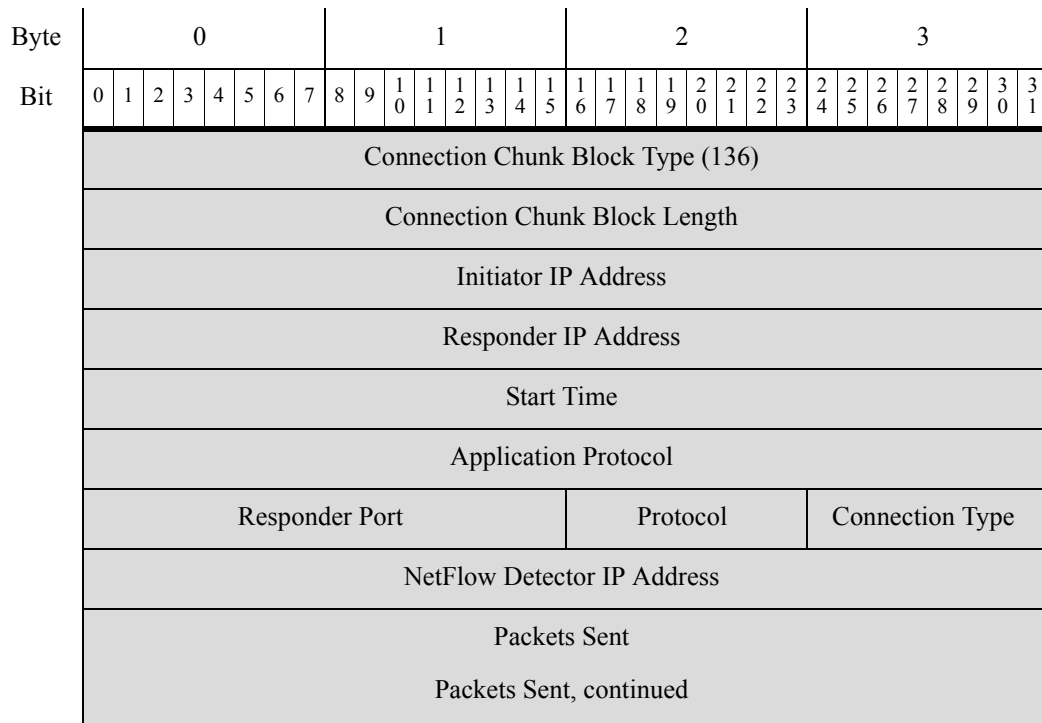

Table 4-53 Address Specification Data Block Fields (continued)

| Field                                      | Number of Bytes | Description  |
|--|-----------------|--|
| IP Address Range Specification Data Blocks | variable        | Encapsulated IP Address Range Specification data blocks up to the maximum number of bytes in the list block length. For more information, see <a href="#">IP Address Range Data Block for 5.2+</a> , page 4-88.        |
| Generic List Block Type                    | uint32          | Initiates a Generic List data block. This value is always 31.  |
| Generic List Block Length                  | uint32          | Number of bytes in the Generic List block and encapsulated data blocks. This number includes the eight bytes of the generic list block header fields, plus the number of bytes in all of the encapsulated data blocks. |
| MAC Address Specification Data Blocks      | variable        | Encapsulated MAC Address Specification data blocks up to the maximum number of bytes in the list block length. For more information, see <a href="#">MAC Address Specification Data Block</a> , page 4-91.             |

## Connection Chunk Data Block for 5.1.1+

The Connection Chunk data block conveys connection data. It stores connection log data that aggregates over a five-minute period. The Connection Chunk data block has a block type of 136 in the series 1 group of blocks. It supersedes block type 119. The following diagram shows the format of the Connection Chunk data block:



| Byte                        | 0 |   |   |   |   |   |   |   | 1 |   |    |    |    |    |    |    | 2  |    |    |    |    |    |    |    | 3  |    |    |    |    |    |    |    |
|-----------------------------|---|---|---|---|---|---|---|---|---|---|----|----|----|----|----|----|----|----|----|----|----|----|----|----|----|----|----|----|----|----|----|----|
| Bit                         | 0 | 1 | 2 | 3 | 4 | 5 | 6 | 7 | 8 | 9 | 10 | 11 | 12 | 13 | 14 | 15 | 16 | 17 | 18 | 19 | 20 | 21 | 22 | 23 | 24 | 25 | 26 | 27 | 28 | 29 | 30 | 31 |
| Packets Received            |   |   |   |   |   |   |   |   |   |   |    |    |    |    |    |    |    |    |    |    |    |    |    |    |    |    |    |    |    |    |    |    |
| Packets Received, continued |   |   |   |   |   |   |   |   |   |   |    |    |    |    |    |    |    |    |    |    |    |    |    |    |    |    |    |    |    |    |    |    |
| Bytes Sent                  |   |   |   |   |   |   |   |   |   |   |    |    |    |    |    |    |    |    |    |    |    |    |    |    |    |    |    |    |    |    |    |    |
| Bytes Sent, continued       |   |   |   |   |   |   |   |   |   |   |    |    |    |    |    |    |    |    |    |    |    |    |    |    |    |    |    |    |    |    |    |    |
| Bytes Received              |   |   |   |   |   |   |   |   |   |   |    |    |    |    |    |    |    |    |    |    |    |    |    |    |    |    |    |    |    |    |    |    |
| Bytes Received, continued   |   |   |   |   |   |   |   |   |   |   |    |    |    |    |    |    |    |    |    |    |    |    |    |    |    |    |    |    |    |    |    |    |
| Connections                 |   |   |   |   |   |   |   |   |   |   |    |    |    |    |    |    |    |    |    |    |    |    |    |    |    |    |    |    |    |    |    |    |

The following table describes the components of the Connection Chunk data block.

**Table 4-54** Connection Chunk Data Block Fields

| Field                         | Data Type | Description  |
|-------------------------------|-----------|--|
| Connection Chunk Block Type   | uint32    | Initiates a Connection Chunk data block. This value is always 136.   |
| Connection Chunk Block Length | uint32    | Total number of bytes in the Connection Chunk data block, including eight bytes for the connection chunk block type and length fields, plus the number of bytes in the connection chunk data that follows. |
| Initiator IP Address          | uint8(4)  | IP address of the initiator of this type of connection. This is used with the responder IP address to identify identical connections.  |
| Responder IP Address          | uint8(4)  | IP address of the responder to this type of connection. This is used with the initiator IP address to identify identical connections.  |
| Start Time                    | uint32    | The starting time for the connection chunk.  |
| Application Protocol          | uint32    | Identification number for the protocol used in the connection.   |
| Responder Port                | uint16    | The port used by the responder in the connection chunk.  |
| Protocol                      | uint8     | The protocol for the packet containing the user information.   |
| Connection Type               | uint8     | The type of connection.  |
| NetFlow Detector IP Address   | uint8[4]  | IP address of the NetFlow device that detected the connection, in IP address octets.   |
| Packets Sent                  | uint64    | The number of packets sent in the connection chunk.  |
| Packets Received              | uint64    | The number of packets received in the connection chunk.  |
| Bytes Sent                    | uint64    | The number of bytes sent in the connection chunk.  |
| Bytes Received                | uint64    | The number of bytes received in the connection chunk.  |
| Connections                   | uint32    | The number of connections over a five-minute period.   |

## Fix List Data Block

The Fix List data block conveys a fix that applies to a host. A Fix List data block for each fix applied to the affected host is included in a User Product data block. The Fix List data block has a block type of 67 in the series 1 group of blocks.

The following diagram shows the format of the Fix List data block:

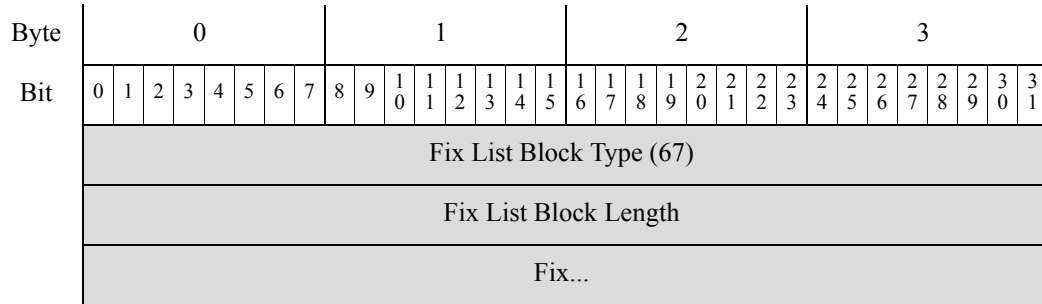

The following table describes the components of the Fix List data block.

Table 4-55 Fix List Data Block Fields

| Field                 | Data Type | Description  |
|-----------------------|-----------|--|
| Fix List Block Type   | uint32    | Initiates a Fix List data block. This value is always 67.  |
| Fix List Block Length | uint32    | Total number of bytes in the Fix List data block, including eight bytes for the Fix List block type and length fields, plus the number of bytes of fix identification data that follows. |
| Fix ID                | uint32    | The identification number for the fix.   |

## User Server Data Block

The User Server data block contains server details from a user input event. The User Server data block has a block type of 76 in the series 1 group of blocks.

The following diagram shows the basic structure of a User Server data block:

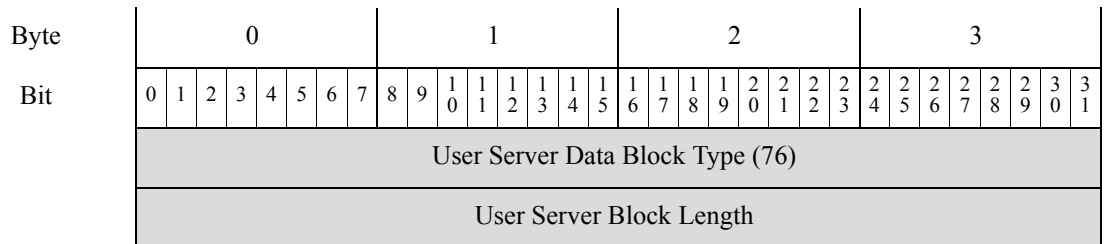

| Byte                   | 0   |   |   |   |   |   |   |   | 1 |   |    |    |    |    |    |    | 2        |    |    |    |    |    |    |    | 3  |    |    |    |    |    |    |    |
|------------------------|---|---|---|---|---|---|---|---|---|---|----|----|----|----|----|----|----------|----|----|----|----|----|----|----|----|----|----|----|----|----|----|----|
| Bit                    | 0   | 1 | 2 | 3 | 4 | 5 | 6 | 7 | 8 | 9 | 10 | 11 | 12 | 13 | 14 | 15 | 16       | 17 | 18 | 19 | 20 | 21 | 22 | 23 | 24 | 25 | 26 | 27 | 28 | 29 | 30 | 31 |
| IP Range Specification | Generic List Block Type (31)                |   |   |   |   |   |   |   |   |   |    |    |    |    |    |    |          |    |    |    |    |    |    |    |    |    |    |    |    |    |    |    |
|                        | Generic List Block Length                   |   |   |   |   |   |   |   |   |   |    |    |    |    |    |    |          |    |    |    |    |    |    |    |    |    |    |    |    |    |    |    |
|                        | IP Address Range Specification Data Blocks* |   |   |   |   |   |   |   |   |   |    |    |    |    |    |    |          |    |    |    |    |    |    |    |    |    |    |    |    |    |    |    |
|                        | Port  |   |   |   |   |   |   |   |   |   |    |    |    |    |    |    | Protocol |    |    |    |    |    |    |    |    |    |    |    |    |    |    |    |

The following table describes the fields of the User Server data block.

**Table 4-56** User Server Data Block Fields

| Field                                      | Number of Bytes | Description   |
|--|-----------------|---|
| User Server Data Block Type                | uint32          | Initiates a User Server data block. This value is always 76.  |
| User Server Block Length                   | uint32          | Total number of bytes in the User Server data block, including eight bytes for the user server block type and length fields, plus the number of bytes of user server data that follows.   |
| Generic List Block Type                    | uint32          | Initiates a Generic List data block. This value is always 31.   |
| Generic List Block Length                  | uint32          | Number of bytes in the Generic List block and encapsulated data blocks. This number includes the eight bytes of the generic list block header fields, plus the number of bytes in all of the encapsulated data blocks.  |
| IP Address Range Specification Data Blocks | variable        | Encapsulated IP Address Range Specification data blocks up to the maximum number of bytes in the list block length.   |
| Port                                       | uint16          | Port used by the server.  |
| Protocol                                   | uint16          | IANA protocol number or Ethertype. This is handled differently for Transport and Network layer protocols.<br><br>Transport layer protocols are identified by the IANA protocol number. For example: <ul style="list-style-type: none"> <li>• 6 - TCP</li> <li>• 17 - UDP</li> </ul> Network layer protocols are identified by the decimal form of the IEEE Registration Authority Ethertype. For example: <ul style="list-style-type: none"> <li>• 2048 - IP</li> </ul> |

## User Server List Data Block

The User Server List data block contains a list of server data blocks from a user input event. The User Server List data block has a block type of 77 in the series 1 group of blocks. The following diagram shows the basic structure of a User Server List data block:

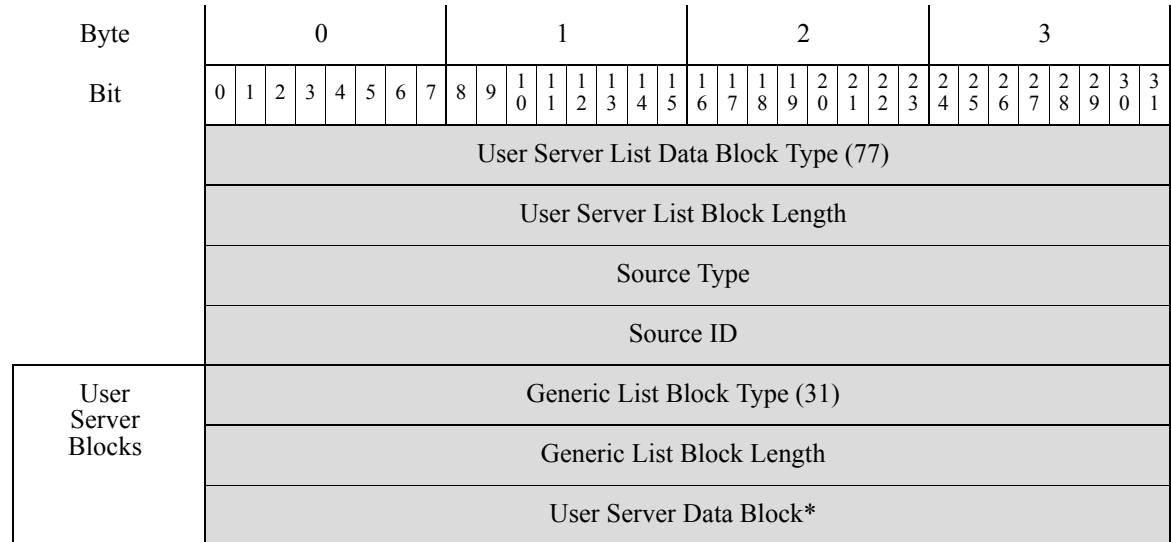

The following table describes the fields of the User Server List data block.

**Table 4-57** User Server List Data Block Fields

| Field                            | Number of Bytes | Description  |
|----------------------------------|-----------------|--|
| User Server List Data Block Type | uint32          | Initiates a User Server List data block. This value is always 77.  |
| User Server List Block Length    | uint32          | Total number of bytes in the User Server List data block, including eight bytes for the user server list block type and length fields, plus the number of bytes of user server list data that follows.   |
| Source Type                      | uint32          | Number that maps to the type of data source: <ul style="list-style-type: none"> <li>0 if the server data was detected by RNA</li> <li>1 if the server data was provided by a user</li> <li>2 if the server data was detected by a third-party scanner</li> <li>3 if the server data was provided by a command line tool such as <code>nmimport.pl</code> or the Host Input API client</li> </ul> |
| Source ID                        | uint32          | Identification number that maps to the source of the server data. Depending on the source type, this may map to RNA, a user, a scanner, or a third-party application.  |
| Generic List Block Type          | uint32          | Initiates a Generic List data block. This value is always 31.  |

Table 4-57 User Server List Data Block Fields (continued)

| Field                     | Number of Bytes | Description  |
|---------------------------|-----------------|--|
| Generic List Block Length | uint32          | Number of bytes in the Generic List block and encapsulated data blocks. This number includes the eight bytes of the generic list block header fields, plus the number of bytes in all of the encapsulated data blocks. |
| User Server Data Blocks   | variable        | Encapsulated User Server data blocks up to the maximum number of bytes in the list block length.   |

## User Hosts Data Block 4.7+

The User Hosts data block is used in [User Add and Delete Host Messages, page 4-48](#) to contain information about host ranges and user and source identity from a user host input event. The User Hosts data block has a block type of 78 in the series 1 group of blocks.

The following diagram shows the basic structure of a User Hosts data block:

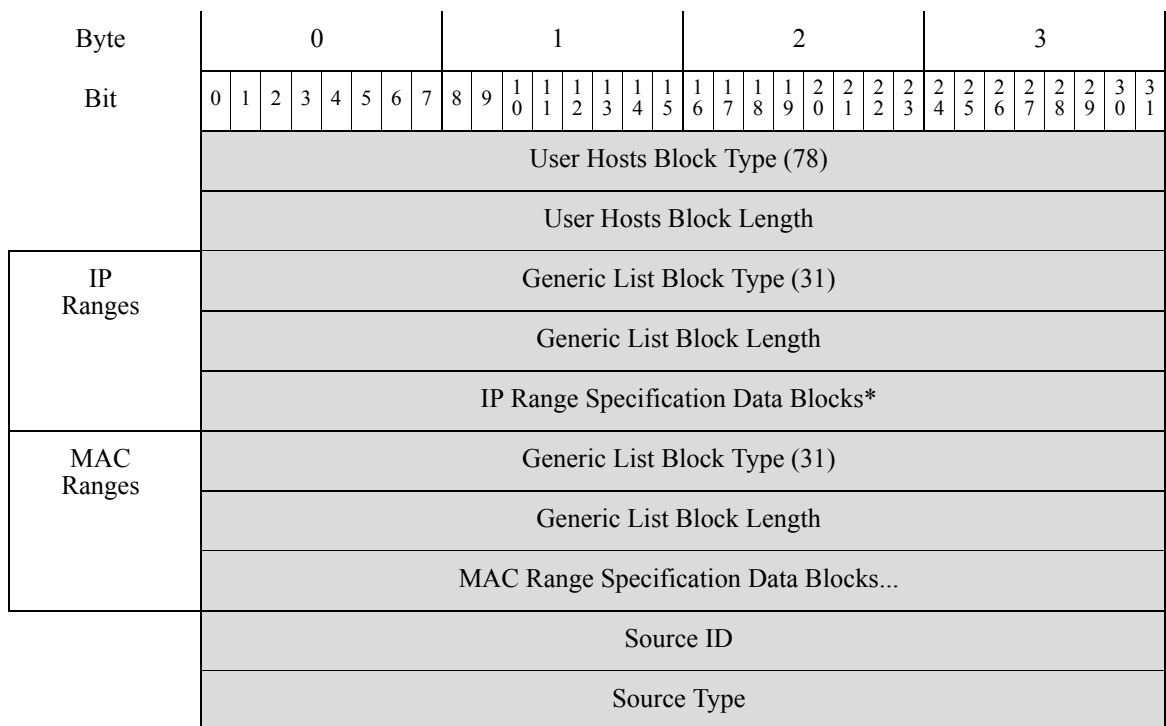

The following table describes the fields of the User Hosts data block.

**Table 4-58** *User Hosts Data Block Fields*

| Field                                 | Number of Bytes | Description  |
|---------------------------------------|-----------------|--|
| User Hosts Block Type                 | uint32          | Initiates a User Hosts data block. This value is always 78.  |
| User Hosts Block Length               | uint32          | Total number of bytes in the User Hosts data block, including eight bytes for the user hosts block type and length fields, plus the number of bytes of user hosts data that follows.   |
| Generic List Block Type               | uint32          | Initiates a Generic List data block comprising IP Range Specification data blocks conveying IP address range data. This value is always 31.  |
| Generic List Block Length             | uint32          | Number of bytes in the Generic List data block, including the list header and all encapsulated IP Range Specification data blocks.   |
| IP Range Specification Data Blocks *  | variable        | IP Range Specification data blocks containing information about the IP address ranges for the user input. See <a href="#">IP Address Range Data Block for 5.2+, page 4-88</a> for a description of this data block.  |
| Generic List Block Type               | uint32          | Initiates a Generic List data block comprising MAC Range Specification data blocks conveying MAC address range data. This value is always 31.  |
| Generic List Block Length             | uint32          | Number of bytes in the Generic List data block, including the list header and all encapsulated MAC Range Specification data blocks.  |
| MAC Range Specification Data Blocks * | variable        | MAC Range Specification data blocks containing information about the MAC address ranges for the user input. See <a href="#">MAC Address Specification Data Block, page 4-91</a> for a description of this data block.  |
| Source ID                             | uint32          | Identification number that maps to the source that added or updated the hostdata. Depending on the source type, this may map to RNA, a user, a scanner, or a third-party application.  |
| Source Type                           | uint32          | Number that maps to the type of data source: <ul style="list-style-type: none"> <li>• 0 if the host data was detected by RNA</li> <li>• 1 if the host data was provided by a user</li> <li>• 2 if the host data was detected by a third-party scanner</li> <li>• 3 if the host data was provided by a command line tool such as <code>nmimport.pl</code> or the Host Input API client</li> </ul> |

## User Vulnerability Change Data Block 4.7+

The User Vulnerability Change data block contains a list of deactivated vulnerabilities for the host, the identification number for the user who deactivated the vulnerabilities, information about the source that supplied the vulnerability changes, and the criticality value. The User Vulnerability Change data block has a block type of 80 in the series 1 group of blocks. Changes from the previous User Vulnerability Change data block include a new source type field and the use of the Generic list data block instead of the List data block to store vulnerability deactivations. This data block is used in user vulnerability change messages as documented in [User Set Vulnerabilities Messages for Version 4.6.1+, page 4-47](#).

The following diagram shows the basic structure of a User Vulnerability Change data block:

| Byte            | 0  |   |   |   |   |   |   |   | 1 |   |    |    |    |    |    |    | 2  |    |    |    |    |    |    |    | 3  |    |    |    |    |    |    |    |
|-----------------|--|---|---|---|---|---|---|---|---|---|----|----|----|----|----|----|----|----|----|----|----|----|----|----|----|----|----|----|----|----|----|----|
| Bit             | 0  | 1 | 2 | 3 | 4 | 5 | 6 | 7 | 8 | 9 | 10 | 11 | 12 | 13 | 14 | 15 | 16 | 17 | 18 | 19 | 20 | 21 | 22 | 23 | 24 | 25 | 26 | 27 | 28 | 29 | 30 | 31 |
|                 | User Vulnerability Change Data Block Type (80) |   |   |   |   |   |   |   |   |   |    |    |    |    |    |    |    |    |    |    |    |    |    |    |    |    |    |    |    |    |    |    |
|                 | User Vulnerability Change Block Length         |   |   |   |   |   |   |   |   |   |    |    |    |    |    |    |    |    |    |    |    |    |    |    |    |    |    |    |    |    |    |    |
|                 | Source ID                                      |   |   |   |   |   |   |   |   |   |    |    |    |    |    |    |    |    |    |    |    |    |    |    |    |    |    |    |    |    |    |    |
|                 | Source Type                                    |   |   |   |   |   |   |   |   |   |    |    |    |    |    |    |    |    |    |    |    |    |    |    |    |    |    |    |    |    |    |    |
| Vuln Ack Blocks | Generic List Block Type (31)                   |   |   |   |   |   |   |   |   |   |    |    |    |    |    |    |    |    |    |    |    |    |    |    |    |    |    |    |    |    |    |    |
|                 | Generic List Block Length                      |   |   |   |   |   |   |   |   |   |    |    |    |    |    |    |    |    |    |    |    |    |    |    |    |    |    |    |    |    |    |    |
|                 | User Vulnerability Data Blocks...*             |   |   |   |   |   |   |   |   |   |    |    |    |    |    |    |    |    |    |    |    |    |    |    |    |    |    |    |    |    |    |    |

The following table describes the fields of the Generic List data block.

**Table 4-59** User Vulnerability Change Data Block Fields

| Field                                     | Number of Bytes | Description  |
|---|-----------------|--|
| User Vulnerability Change Data Block Type | uint32          | Initiates a User Vulnerability Change data block. This value is always 80.   |
| User Vulnerability Change Block Length    | uint32          | Total number of bytes in the User Vulnerability Change data block, including eight bytes for the host vulnerability block type and length fields, plus the number of bytes of host vulnerability data that follows.  |
| Source ID                                 | uint32          | Identification number that maps to the source that updated or added the host vulnerability change value. Depending on the source type, this may map to RNA, a user, a scanner, or a third-party application.   |
| Source Type                               | uint32          | Number that maps to the type of data source: <ul style="list-style-type: none"> <li>0 if the host vulnerability data was detected by RNA</li> <li>1 if the host vulnerability data was provided by a user</li> <li>2 if the host vulnerability data was detected by a third-party scanner</li> <li>3 if the host vulnerability data was provided by a command line tool such as <code>nmimport.pl</code> or the Host Input API client</li> </ul> |
| Type                                      | uint32          | Type of vulnerability.   |
| Generic List Block Type                   | uint32          | Initiates a Generic List data block. This value is always 31.  |



Table 4-59 User Vulnerability Change Data Block Fields (continued)

| Field                          | Number of Bytes | Description  |
|--------------------------------|-----------------|--|
| Generic List Block Length      | uint32          | Number of bytes in the Generic List block and encapsulated data blocks. This number includes the eight bytes of the generic list block header fields, plus the number of bytes in all of the encapsulated data blocks. |
| User Vulnerability Data Blocks | variable        | Encapsulated User Vulnerability data blocks up to the maximum number of bytes in the list block length. For more information, see <a href="#">User Vulnerability Data Block 5.0+</a> , page 4-139.                     |

## User Criticality Change Data Block 4.7+

The User Criticality data block is used to contain a list of IP address range specifications for hosts where the host criticality changed, the identification number for the user who updated the criticality value, information about the source that supplied the criticality value, and the criticality value. The User Criticality data block has a block type of 81 in the series 1 group of blocks. Changes from the previous User Criticality data block include a new source type field and the use of the Generic list data block instead of the List data block to store IP addresses.

The User Criticality data block is used in user set host criticality messages as documented in [User Set Host Criticality Messages](#), page 4-49.

The following diagram shows the basic structure of a User Criticality data block:

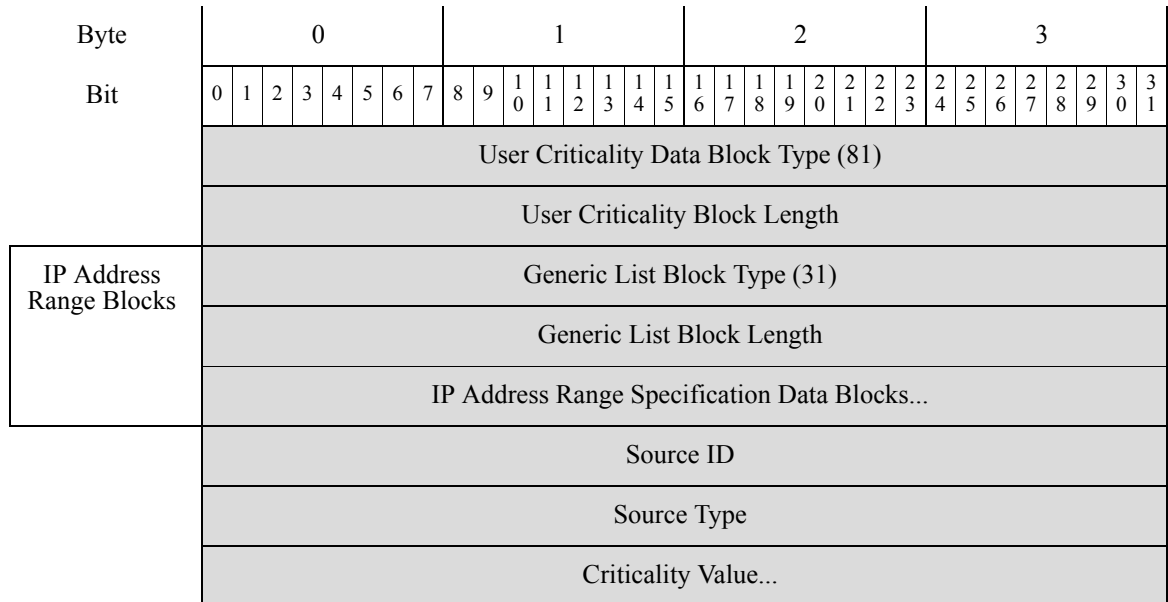

The following table describes the fields of the User Criticality data block.

**Table 4-60** *User Criticality Data Block Fields*

| Field                                      | Number of Bytes | Description  |
|--|-----------------|--|
| User Criticality Data Block Type           | uint32          | Initiates a User Criticality data block. This value is always 81.  |
| User Criticality Block Length              | uint32          | Total number of bytes in the User Criticality data block, including eight bytes for the user criticality block type and length fields, plus the number of bytes of user criticality data that follows.   |
| Generic List Block Type                    | uint32          | Initiates a Generic List data block. This value is always 31.  |
| Generic List Block Length                  | uint32          | Number of bytes in the Generic List block and encapsulated data blocks. This number includes the eight bytes of the generic list block header fields, plus the number of bytes in all of the encapsulated data blocks.   |
| IP Address Range Specification Data Blocks | variable        | Encapsulated IP Address Range Specification data blocks up to the maximum number of bytes in the list block length.  |
| Source ID                                  | uint32          | Identification number that maps to the source that updated or added the user criticality value. Depending on the source type, this may map to RNA, a user, a scanner, or a third-party application.  |
| Source Type                                | uint32          | Number that maps to the type of data source: <ul style="list-style-type: none"> <li>• 0 if the user criticality value was provided by RNA</li> <li>• 1 if the user criticality value was provided by a user</li> <li>• 2 if the user criticality value was provided by a third-party scanner</li> <li>• 3 if the user criticality value was provided by a command line tool such as <code>nmimport.pl</code> or the Host Input API client</li> </ul> |
| Criticality Value                          | uint32          | User criticality value.  |

## User Attribute Value Data Block 4.7+

The User Attribute Value data block contains a list of IP address ranges that indicate the hosts where the attribute value has changed, together with the identification number for the user who added the attribute value, information about the source that supplied the attribute value, and the BLOB data block containing the attribute value. The User Attribute Value data block has a block type of 82 in the series 1 group of blocks. Changes from the previous User Attribute Value data block include a new source type field and the use of the Generic list data block instead of the List data block to store IP addresses.

The following diagram shows the structure of a User Attribute Value data block:

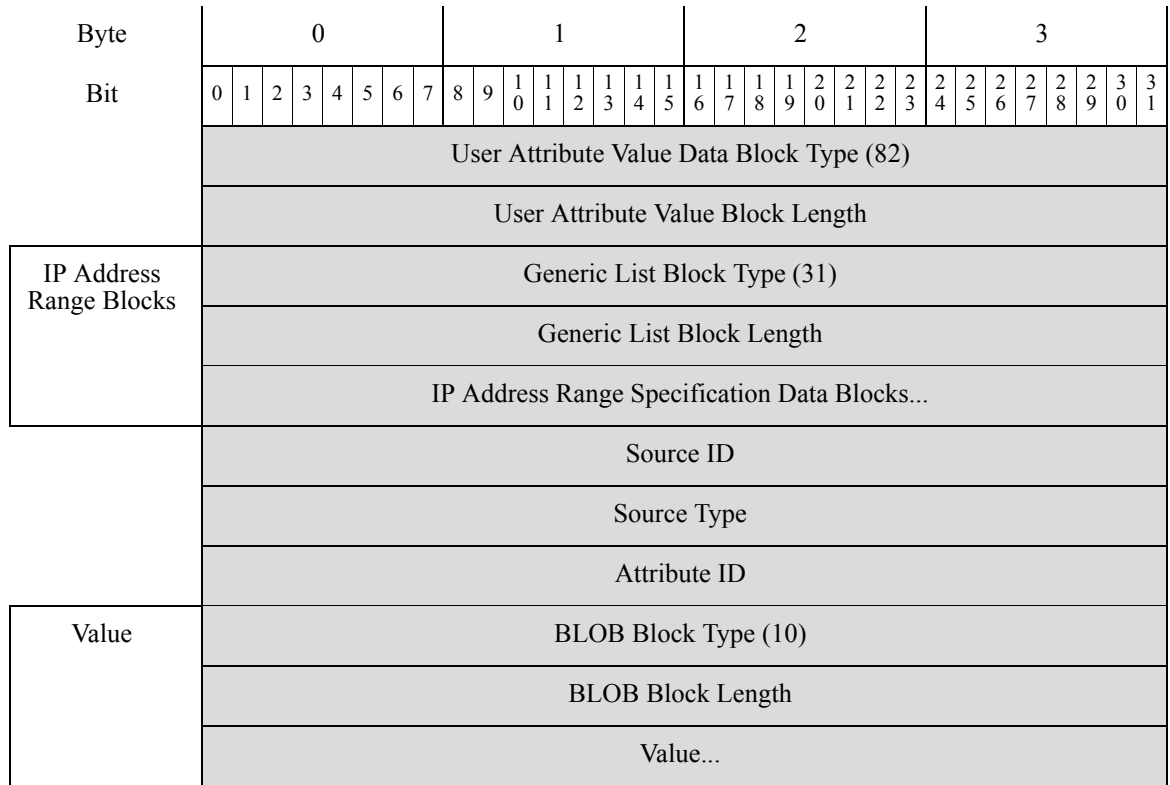

The following table describes the fields of the User Attribute Value data block.

**Table 4-61** User Attribute Value Data Block Fields

| Field                                      | Number of Bytes | Description  |
|--|-----------------|--|
| User Attribute Value Data Block Type       | uint32          | Initiates a User Attribute Value data block. This value is always 82.  |
| User Attribute Value Block Length          | uint32          | Total number of bytes in the Attribute Value data block, including eight bytes for the user attribute value block type and length fields, plus the number of bytes of user attribute value data that follows.          |
| Generic List Block Type                    | uint32          | Initiates a Generic List data block. This value is always 31.  |
| Generic List Block Length                  | uint32          | Number of bytes in the Generic List block and encapsulated data blocks. This number includes the eight bytes of the generic list block header fields, plus the number of bytes in all of the encapsulated data blocks. |
| IP Address Range Specification Data Blocks | variable        | IP Address Range Specification data blocks (each with a start IP address and end IP address) up to the maximum number of bytes in the list block length.   |

Table 4-61 User Attribute Value Data Block Fields (continued)

| Field             | Number of Bytes | Description  |
|-------------------|-----------------|--|
| Source ID         | uint32          | Identification number that maps to the source that added or updated the attribute data. Depending on the source type, this may map to RNA, a user, a scanner, or a third-party application.  |
| Source Type       | uint32          | Number that maps to the type of data source: <ul style="list-style-type: none"> <li>0 if the user attribute value was provided by RNA</li> <li>1 if the user attribute value was provided by a user</li> <li>2 if the user attribute value was provided by a third-party scanner</li> <li>3 if the user attribute value was provided by a command line tool such as <code>nmimport.pl</code> or the Host Input API client</li> </ul> |
| Attribute ID      | uint32          | Identification number of the updated attribute.  |
| BLOB Block Type   | uint32          | Initiates a BLOB data block. This value is always 10.  |
| BLOB Block Length | uint32          | Number of bytes in the BLOB data block, including eight bytes for the BLOB block type and length fields, plus the length of the binary data that follows.  |
| Value             | variable        | Contains the user attribute value, in binary format.   |

## User Protocol List Data Block 4.7+

The User Protocol List data block is used to contain information about the source of the protocol data, the identification number for the user who added the data, and the lists of user protocol data blocks. The User Protocol List data block has a block type of 83 in the series 1 group of blocks. For more information on User Protocol data blocks, see [User Protocol Data Block, page 4-83](#).

The User Protocol List data block is used in user protocol messages, as documented in [User Protocol Messages, page 4-51](#).

The following diagram shows the basic structure of a User Protocol List data block:

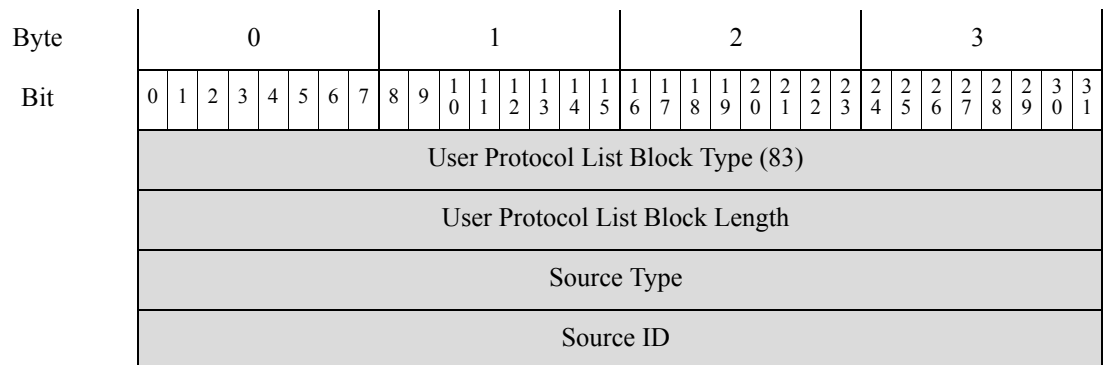

|                      |                              |   |   |   |   |   |   |   |   |   |    |    |    |    |    |    |    |    |    |    |    |    |    |    |    |    |    |    |    |    |    |    |
|----------------------|------------------------------|---|---|---|---|---|---|---|---|---|----|----|----|----|----|----|----|----|----|----|----|----|----|----|----|----|----|----|----|----|----|----|
| Byte                 | 0                            |   |   |   |   |   |   |   | 1 |   |    |    |    |    |    |    | 2  |    |    |    |    |    |    |    | 3  |    |    |    |    |    |    |    |
| Bit                  | 0                            | 1 | 2 | 3 | 4 | 5 | 6 | 7 | 8 | 9 | 10 | 11 | 12 | 13 | 14 | 15 | 16 | 17 | 18 | 19 | 20 | 21 | 22 | 23 | 24 | 25 | 26 | 27 | 28 | 29 | 30 | 31 |
| User Protocol Blocks | Generic List Block Type (31) |   |   |   |   |   |   |   |   |   |    |    |    |    |    |    |    |    |    |    |    |    |    |    |    |    |    |    |    |    |    |    |
|                      | Generic List Block Length    |   |   |   |   |   |   |   |   |   |    |    |    |    |    |    |    |    |    |    |    |    |    |    |    |    |    |    |    |    |    |    |
|                      | User Protocol Data Blocks... |   |   |   |   |   |   |   |   |   |    |    |    |    |    |    |    |    |    |    |    |    |    |    |    |    |    |    |    |    |    |    |

The following table describes the fields of the Generic List data block.

**Table 4-62** User Protocol List Data Block Fields

| Field                           | Number of Bytes | Description  |
|---------------------------------|-----------------|--|
| User Protocol List Block Type   | uint32          | Initiates a User Protocol List data block. This value is always 83.  |
| User Protocol List Block Length | uint32          | Total number of bytes in the User Protocol List data block, including eight bytes for the user protocol list block type and length fields, plus the number of bytes of user protocol list data that follows.   |
| Source Type                     | uint32          | Number that maps to the type of data source: <ul style="list-style-type: none"> <li>• 0 if the protocol data was provided by RNA</li> <li>• 1 if the protocol data was provided by a user</li> <li>• 2 if the protocol data was provided by a third-party scanner</li> <li>• 3 if the protocol data was provided by a command line tool such as <code>nmimport.pl</code> or the Host Input API client</li> </ul> |
| Source ID                       | uint32          | Identification number that maps to the source of the affected protocols. Depending on the source type, this may map to RNA, a user, a scanner, or a third-party application.   |
| Generic List Block Type         | uint32          | Initiates a Generic List data block. This value is always 31.  |
| Generic List Block Length       | uint32          | Number of bytes in the Generic List block and encapsulated data blocks. This number includes the eight bytes of the generic list block header fields, plus the number of bytes in all of the encapsulated data blocks.   |
| User Protocol Data Blocks       | variable        | Encapsulated User Protocol data blocks up to the maximum number of bytes in the list block length.   |

## Host Vulnerability Data Block 4.9.0+

The Host Vulnerability data block conveys vulnerabilities that apply to a host. Each Host Vulnerability data block describes one vulnerability for a host in an event. Host Vulnerability data blocks appear in the Full Host Profile, Full Host Server, and Full Sub-Server data blocks. The Host Vulnerability data block has a block type of 85 in the series 1 group of blocks.

The following diagram shows the format of the Host Vulnerability data block:

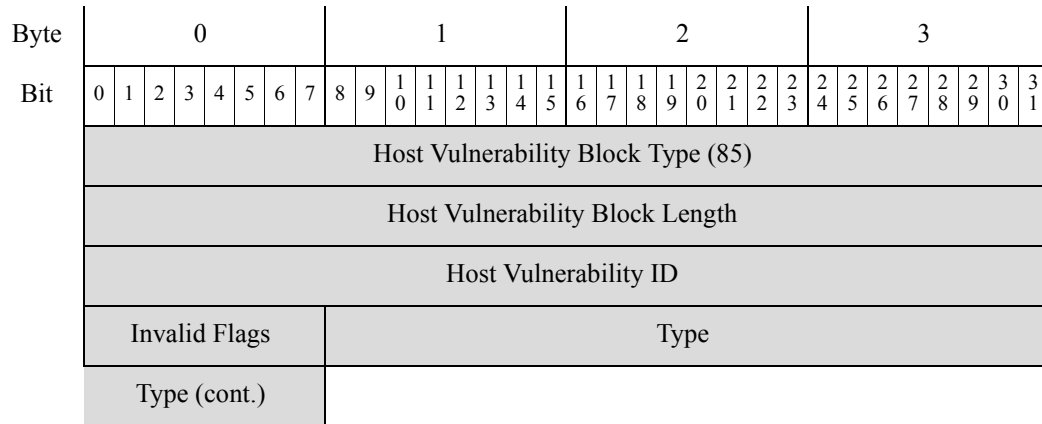

The following table describes the components of the Host Vulnerability data block.

**Table 4-63** Host Vulnerability Data Block Fields

| Field                           | Data Type | Description  |
|---------------------------------|-----------|--|
| Host Vulnerability Block Type   | uint32    | Initiates an Host Vulnerability data block. This value is always 85.   |
| Host Vulnerability Block Length | uint32    | Total number of bytes in the Host Vulnerability data block, including eight bytes for the host vulnerability block type and length fields, plus the number of bytes of host vulnerability data that follows. |
| Host Vulnerability ID           | uint32    | The identification number for the vulnerability.   |
| Invalid Flags                   | uint8     | A value indicating whether the vulnerability is valid for the host.  |
| Type                            | uint32    | The type of vulnerability.   |

## Identity Data Block

The identity data block has a block type of 94 in the series 1 group of blocks. Identity data blocks are used in identity conflict and identity timeout messages, which indicate when the identities of an operating system or server fingerprint source conflict or time out. The data block describes reported identities that have been identified as being in conflict with active source identities (user, scanner, or application). For more information, see [Identity Conflict and Identity Timeout System Messages](#), page 4-53.

The following diagram shows the format of an identity data block for 4.9+.

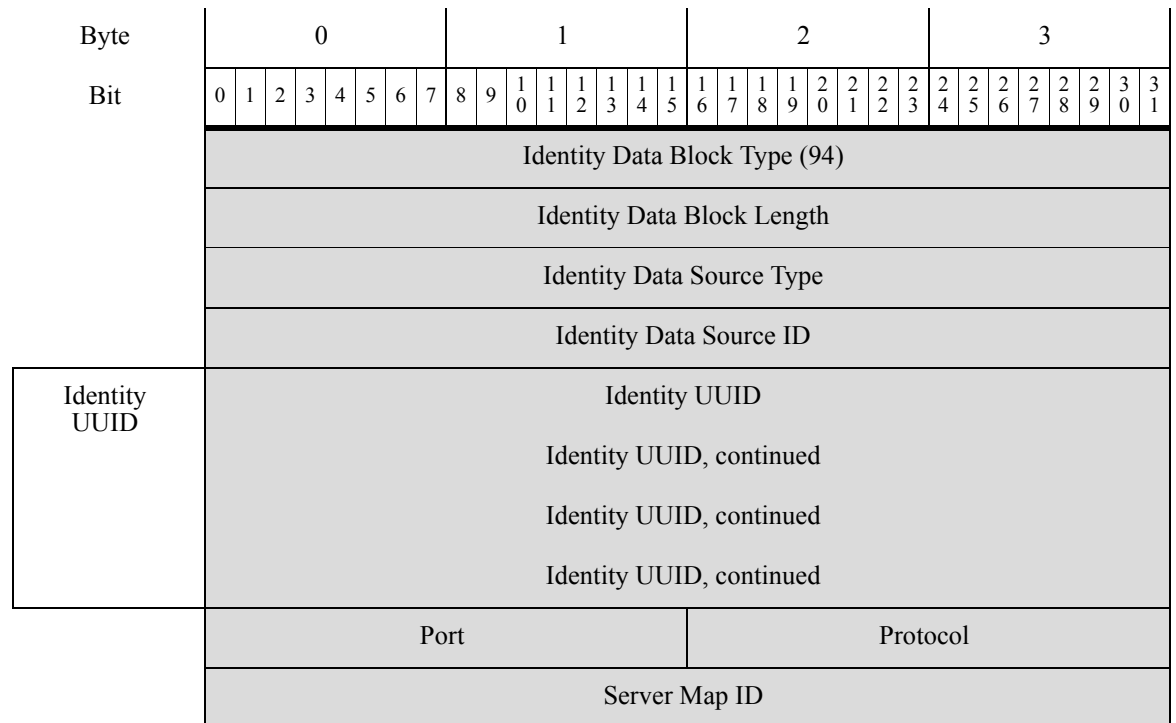

The following table describes the fields of the Cisco identity data block.

**Table 4-64 Identity Data Block Fields**

| Field                      | Data Type | Description  |
|----------------------------|-----------|--|
| Identity Data Block Type   | uint32    | Initiates the Identity data block. This value is always 94.  |
| Identity Data Block Length | uint32    | Number of bytes in the Identity data block. This value should always be 40: sixteen bytes for the data block type and length fields and the source type and ID fields, sixteen bytes for the fingerprint UUID value, two bytes for the port, two bytes for the protocol, and four bytes for the SM ID.   |
| Identity Data Source Type  | uint32    | Number that maps to the type of data source: <ul style="list-style-type: none"> <li>• 0 if the fingerprint data was provided by RNA</li> <li>• 1 if the fingerprint data was provided by a user</li> <li>• 2 if the fingerprint data was provided by a third-party scanner</li> <li>• 3 if the fingerprint data was provided by a command line tool such as <code>nmimport.pl</code> or the Host Input API client</li> </ul> |
| Identity Data Source ID    | uint32    | Identification number that maps to the source of the fingerprint data. Depending on the source type, this may map to RNA, a user, a scanner, or a third-party application.   |
| UUID                       | uint8[16] | If the identity is an operating system identity, the identification number, in octets, that acts as a unique identifier for the fingerprint.   |

Table 4-64 Identity Data Block Fields (continued)

| Field         | Data Type | Description   |
|---------------|-----------|---|
| Port          | uint16    | If the identity is a server identity, indicates the port used by the packet containing the server data.   |
| Protocol      | uint16    | <p>If the identity is a server identity, indicates the IANA number of the network protocol or Ethertype used by the packet containing the server data. This is handled differently for Transport and Network layer protocols.</p> <p>Transport layer protocols are identified by the IANA protocol number. For example:</p> <ul style="list-style-type: none"> <li>6 - TCP</li> <li>7 - UDP</li> </ul> <p>Network layer protocols are identified by the decimal form of the IEEE Registration Authority Ethertype. For example:</p> <ul style="list-style-type: none"> <li>2048 - IP</li> </ul> |
| Server Map ID | uint32    | If the identity is a server identity, indicates the server map ID, representing the combination of ID, vendor, and version for the server.  |

## Host MAC Address 4.9+

The host MAC address data block has a block type of 95 in the series 1 group of blocks. The block includes the time-to-live value for the host data, as well as the MAC address, the primary subnet of the host, and the last seen value for the host.

The following diagram shows the format of a host MAC address data block in 4.9+.

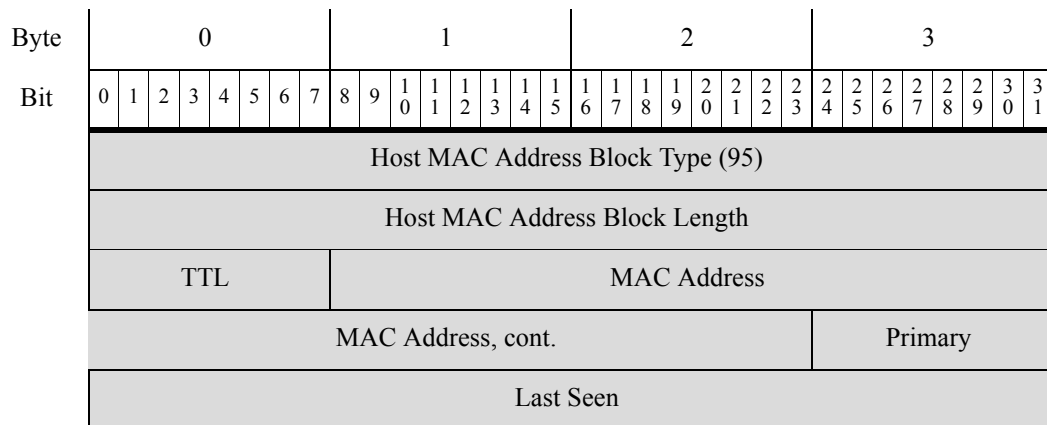



The following table describes the fields of the Host MAC Address data block.

*Table 4-65 Host MAC Address Data Block Fields*

| Field                              | Data Type | Description  |
|------------------------------------|-----------|--|
| Host MAC Address Data Block Type   | uint32    | Initiates the Host MAC Address data block. This value is always 95.  |
| Host MAC Address Data Block Length | uint32    | Number of bytes in the Host MAC Address data block. This value should always be 20: eight bytes for the data block type and length fields, one byte for the TTL value, 6 bytes for the MAC address, one byte for the primary subnet, and four bytes for the last seen value. |
| TTL                                | uint8     | Indicates the difference between the TTL value in the packet used to fingerprint the host.   |
| MAC Address                        | uint8 [6] | Indicates the MAC address of the host.   |
| Primary                            | uint8     | Indicates the primary subnet of the host.  |
| Last Seen                          | uint32    | Indicates when the host was last seen in traffic.  |

## Secondary Host Update

The Secondary Host Update data block contains information for a host sent as a secondary host update from a device monitoring a subnet other than that where the host resides. It is used within Change Secondary Update events (event type 1001, subtype 31). The Secondary Host Update data block has a block type of 96 in the series 1 group of blocks.

The following diagram shows the format of a Secondary Host Update data block:

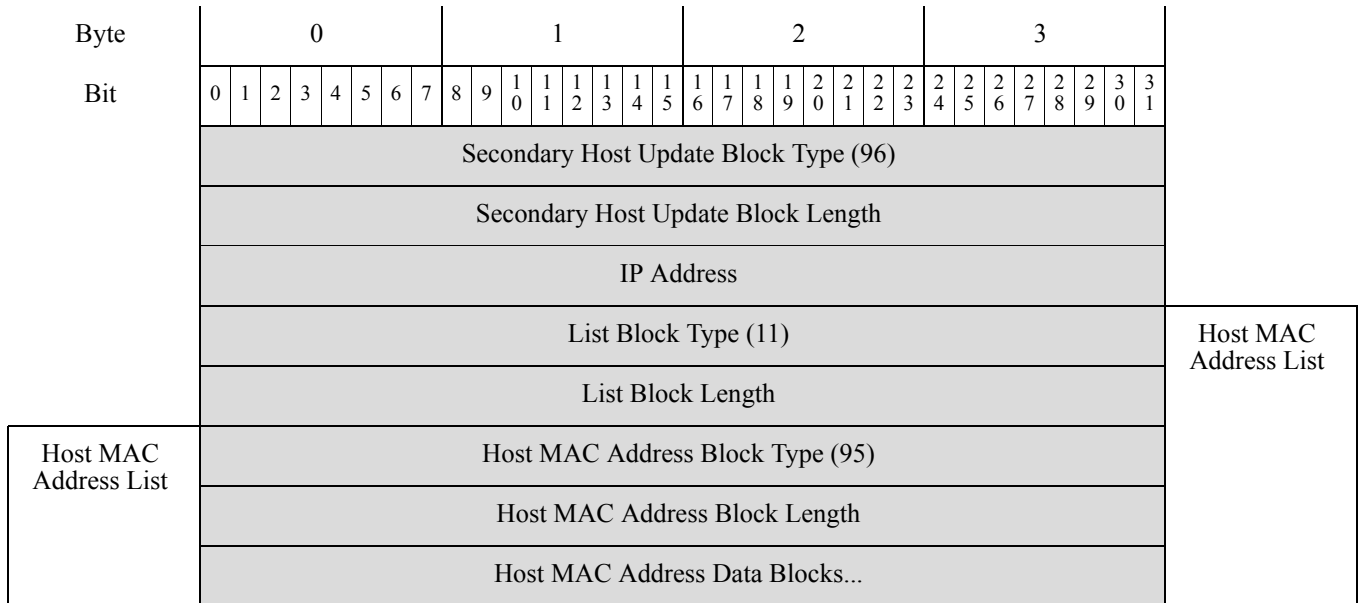

The following table describes the fields of the Secondary Host Update data block.

**Table 4-66** Secondary Host Update Data Block Fields

| Field                              | Data Type | Description  |
|------------------------------------|-----------|--|
| Secondary Host Update Block Type   | uint32    | Initiates a Secondary Host Update data block. This value is always 96.   |
| Secondary Host Update Block Length | uint32    | Number of bytes in the Secondary Host Update data block, including eight bytes for the secondary host update block type and length fields, plus the number of bytes of secondary host update data that follows.  |
| IP Address                         | uint8[4]  | IP address of the host described in the update, in IP address octets.  |
| List Block Type                    | uint32    | Initiates a List data block comprising Host MAC Address data blocks conveying host MAC address data. This value is always 11.  |
| List Block Length                  | uint32    | Number of bytes in the list. This number includes the eight bytes of the list block type and length fields, plus all encapsulated Host MAC Address data blocks.<br><br>This field is followed by zero or more Host MAC Address data blocks.                                    |
| Host MAC Address Block Type        | uint32    | Initiates a Host MAC Address data block describing the secondary host. This value is always 95.  |
| Host MAC Address Data Block Length | uint32    | Number of bytes in the Host MAC Address data block. This value should always be 20: eight bytes for the data block type and length fields, one byte for the TTL value, six bytes for the MAC address, one byte for the primary subnet, and four bytes for the last seen value. |
| Host MAC Address Data Blocks       | string    | Information related to MAC addresses of hosts in the update.   |

## Web Application Data Block for 5.0+

The Web Application data block for 5.0+ has a block type of 123 in the series 1 group of blocks. The data block describes the web application from detected HTTP client requests.

The following diagram shows the format of a Web Application data block in 5.0+.

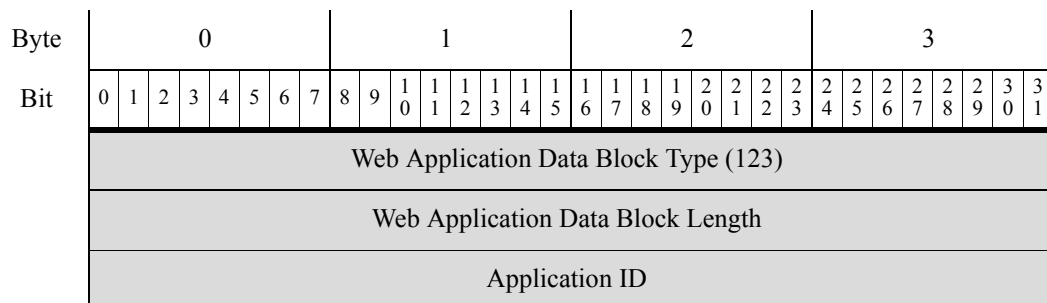

The following table describes the fields of the Web Application data block.

**Table 4-67 Web Application Data Block Fields**

| Field                             | Data Type | Description   |
|-----------------------------------|-----------|---|
| Web Application Data Block Type   | uint32    | Initiates the Web Application data block. This value is always 123.   |
| Web Application Data Block Length | uint32    | Number of bytes in the Web Application data block, including eight bytes for the Web Application data block type and length, plus the number of bytes in the application ID field that follows. |
| Application ID                    | uint32    | Application ID of the web application.  |

## Connection Statistics Data Block 5.3.1+

The connection statistics data block is used in connection data messages. The only changes to the connection data block between versions 5.3 and 5.3.1 is the addition of a security context field. The connection statistics data block for version 5.3.1+ has a block type of 154 in the series 1 group of blocks. It deprecates block type 152, [Connection Statistics Data Block 5.3, page B-102](#).

You request connection event records by setting the extended event flag—bit 30 in the Request Flags field—in the request message with an event version of 11 and an event code of 71. See [Request Flags, page 2-11](#). If you enable bit 23, an extended event header is included in the record. For more information on the Connection Statistics Data message, see [Connection Statistics Data Message, page 4-46](#).

The following diagram shows the format of a Connection Statistics data block for 5.3.1+:

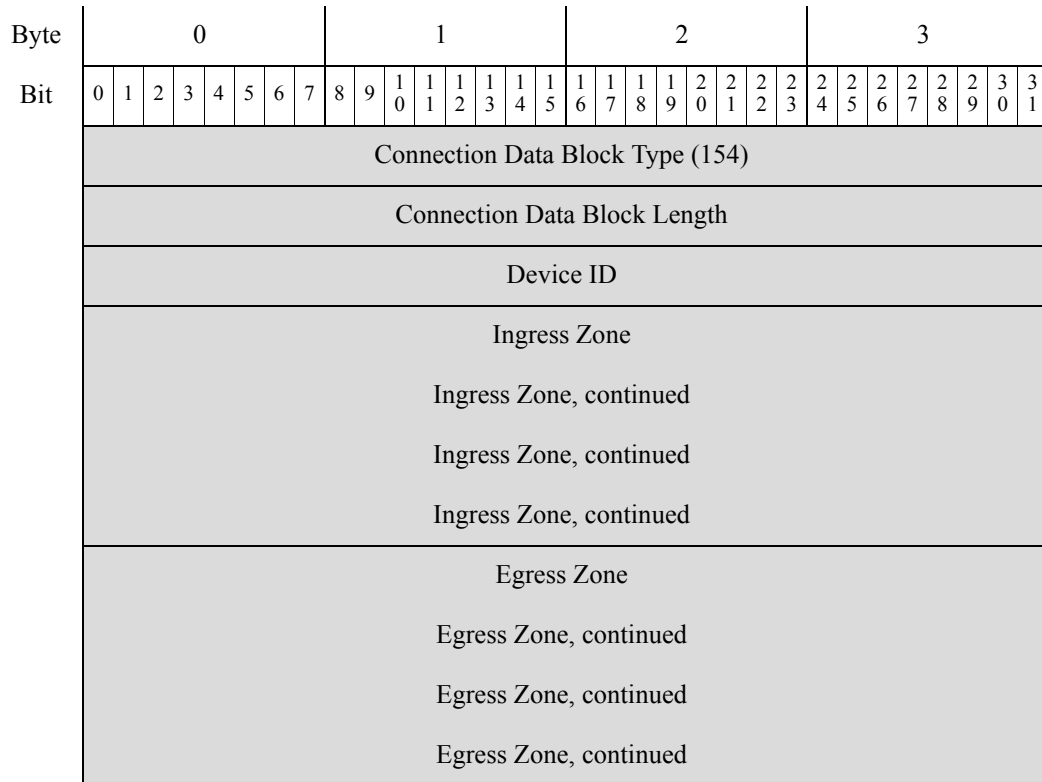

| Byte                            | 0 |   |   |   |   |   |   |   | 1 |   |    |    |    |    |    |                | 2  |    |    |    |    |    |    |                | 3  |    |    |    |    |    |    |    |
|---------------------------------|---|---|---|---|---|---|---|---|---|---|----|----|----|----|----|----------------|----|----|----|----|----|----|----|----------------|----|----|----|----|----|----|----|----|
| Bit                             | 0 | 1 | 2 | 3 | 4 | 5 | 6 | 7 | 8 | 9 | 10 | 11 | 12 | 13 | 14 | 15             | 16 | 17 | 18 | 19 | 20 | 21 | 22 | 23             | 24 | 25 | 26 | 27 | 28 | 29 | 30 | 31 |
| Ingress Interface               |   |   |   |   |   |   |   |   |   |   |    |    |    |    |    |                |    |    |    |    |    |    |    |                |    |    |    |    |    |    |    |    |
| Ingress Interface, continued    |   |   |   |   |   |   |   |   |   |   |    |    |    |    |    |                |    |    |    |    |    |    |    |                |    |    |    |    |    |    |    |    |
| Ingress Interface, continued    |   |   |   |   |   |   |   |   |   |   |    |    |    |    |    |                |    |    |    |    |    |    |    |                |    |    |    |    |    |    |    |    |
| Ingress Interface, continued    |   |   |   |   |   |   |   |   |   |   |    |    |    |    |    |                |    |    |    |    |    |    |    |                |    |    |    |    |    |    |    |    |
| Egress Interface                |   |   |   |   |   |   |   |   |   |   |    |    |    |    |    |                |    |    |    |    |    |    |    |                |    |    |    |    |    |    |    |    |
| Egress Interface, continued     |   |   |   |   |   |   |   |   |   |   |    |    |    |    |    |                |    |    |    |    |    |    |    |                |    |    |    |    |    |    |    |    |
| Egress Interface, continued     |   |   |   |   |   |   |   |   |   |   |    |    |    |    |    |                |    |    |    |    |    |    |    |                |    |    |    |    |    |    |    |    |
| Egress Interface, continued     |   |   |   |   |   |   |   |   |   |   |    |    |    |    |    |                |    |    |    |    |    |    |    |                |    |    |    |    |    |    |    |    |
| Initiator IP Address            |   |   |   |   |   |   |   |   |   |   |    |    |    |    |    |                |    |    |    |    |    |    |    |                |    |    |    |    |    |    |    |    |
| Initiator IP Address, continued |   |   |   |   |   |   |   |   |   |   |    |    |    |    |    |                |    |    |    |    |    |    |    |                |    |    |    |    |    |    |    |    |
| Initiator IP Address, continued |   |   |   |   |   |   |   |   |   |   |    |    |    |    |    |                |    |    |    |    |    |    |    |                |    |    |    |    |    |    |    |    |
| Initiator IP Address, continued |   |   |   |   |   |   |   |   |   |   |    |    |    |    |    |                |    |    |    |    |    |    |    |                |    |    |    |    |    |    |    |    |
| Responder IP Address            |   |   |   |   |   |   |   |   |   |   |    |    |    |    |    |                |    |    |    |    |    |    |    |                |    |    |    |    |    |    |    |    |
| Responder IP Address, continued |   |   |   |   |   |   |   |   |   |   |    |    |    |    |    |                |    |    |    |    |    |    |    |                |    |    |    |    |    |    |    |    |
| Responder IP Address, continued |   |   |   |   |   |   |   |   |   |   |    |    |    |    |    |                |    |    |    |    |    |    |    |                |    |    |    |    |    |    |    |    |
| Responder IP Address, continued |   |   |   |   |   |   |   |   |   |   |    |    |    |    |    |                |    |    |    |    |    |    |    |                |    |    |    |    |    |    |    |    |
| Policy Revision                 |   |   |   |   |   |   |   |   |   |   |    |    |    |    |    |                |    |    |    |    |    |    |    |                |    |    |    |    |    |    |    |    |
| Policy Revision, continued      |   |   |   |   |   |   |   |   |   |   |    |    |    |    |    |                |    |    |    |    |    |    |    |                |    |    |    |    |    |    |    |    |
| Policy Revision, continued      |   |   |   |   |   |   |   |   |   |   |    |    |    |    |    |                |    |    |    |    |    |    |    |                |    |    |    |    |    |    |    |    |
| Policy Revision, continued      |   |   |   |   |   |   |   |   |   |   |    |    |    |    |    |                |    |    |    |    |    |    |    |                |    |    |    |    |    |    |    |    |
| Rule ID                         |   |   |   |   |   |   |   |   |   |   |    |    |    |    |    |                |    |    |    |    |    |    |    |                |    |    |    |    |    |    |    |    |
| Rule Action                     |   |   |   |   |   |   |   |   |   |   |    |    |    |    |    | Rule Reason    |    |    |    |    |    |    |    |                |    |    |    |    |    |    |    |    |
| Initiator Port                  |   |   |   |   |   |   |   |   |   |   |    |    |    |    |    | Responder Port |    |    |    |    |    |    |    |                |    |    |    |    |    |    |    |    |
| TCP Flags                       |   |   |   |   |   |   |   |   |   |   |    |    |    |    |    | Protocol       |    |    |    |    |    |    |    | NetFlow Source |    |    |    |    |    |    |    |    |
| NetFlow Source, continued       |   |   |   |   |   |   |   |   |   |   |    |    |    |    |    |                |    |    |    |    |    |    |    |                |    |    |    |    |    |    |    |    |
| NetFlow Source, continued       |   |   |   |   |   |   |   |   |   |   |    |    |    |    |    |                |    |    |    |    |    |    |    |                |    |    |    |    |    |    |    |    |

| Byte         | 0  |   |   |   |   |   |   |   | 1                  |   |    |    |    |    |    |    | 2  |    |    |    |    |    |    |    | 3                    |    |    |    |    |    |    |    |
|--------------|--|---|---|---|---|---|---|---|--------------------|---|----|----|----|----|----|----|----|----|----|----|----|----|----|----|----------------------|----|----|----|----|----|----|----|
| Bit          | 0  | 1 | 2 | 3 | 4 | 5 | 6 | 7 | 8                  | 9 | 10 | 11 | 12 | 13 | 14 | 15 | 16 | 17 | 18 | 19 | 20 | 21 | 22 | 23 | 24                   | 25 | 26 | 27 | 28 | 29 | 30 | 31 |
|              | NetFlow Source, continued                |   |   |   |   |   |   |   |                    |   |    |    |    |    |    |    |    |    |    |    |    |    |    |    |                      |    |    |    |    |    |    |    |
|              | NetFlow Source, continued                |   |   |   |   |   |   |   |                    |   |    |    |    |    |    |    |    |    |    |    |    |    |    |    | Instance ID          |    |    |    |    |    |    |    |
|              | Instance ID, cont.                       |   |   |   |   |   |   |   | Connection Counter |   |    |    |    |    |    |    |    |    |    |    |    |    |    |    | First Pkt Time       |    |    |    |    |    |    |    |
|              | First Packet Timestamp, continued        |   |   |   |   |   |   |   |                    |   |    |    |    |    |    |    |    |    |    |    |    |    |    |    | Last Pkt Time        |    |    |    |    |    |    |    |
|              | Last Packet Timestamp, continued         |   |   |   |   |   |   |   |                    |   |    |    |    |    |    |    |    |    |    |    |    |    |    |    | Initiator Tx Packets |    |    |    |    |    |    |    |
|              | Initiator Transmitted Packets, continued |   |   |   |   |   |   |   |                    |   |    |    |    |    |    |    |    |    |    |    |    |    |    |    |                      |    |    |    |    |    |    |    |
|              | Initiator Transmitted Packets, continued |   |   |   |   |   |   |   |                    |   |    |    |    |    |    |    |    |    |    |    |    |    |    |    | Resp. Tx Packets     |    |    |    |    |    |    |    |
|              | Responder Transmitted Packets, continued |   |   |   |   |   |   |   |                    |   |    |    |    |    |    |    |    |    |    |    |    |    |    |    |                      |    |    |    |    |    |    |    |
|              | Responder Transmitted Packets, continued |   |   |   |   |   |   |   |                    |   |    |    |    |    |    |    |    |    |    |    |    |    |    |    | Initiator Tx Bytes   |    |    |    |    |    |    |    |
|              | Initiator Transmitted Bytes, continued   |   |   |   |   |   |   |   |                    |   |    |    |    |    |    |    |    |    |    |    |    |    |    |    |                      |    |    |    |    |    |    |    |
|              | Initiator Transmitted Bytes, continued   |   |   |   |   |   |   |   |                    |   |    |    |    |    |    |    |    |    |    |    |    |    |    |    | Resp. Tx Bytes       |    |    |    |    |    |    |    |
|              | Responder Transmitted Bytes, continued   |   |   |   |   |   |   |   |                    |   |    |    |    |    |    |    |    |    |    |    |    |    |    |    |                      |    |    |    |    |    |    |    |
|              | Responder Transmitted Bytes, continued   |   |   |   |   |   |   |   |                    |   |    |    |    |    |    |    |    |    |    |    |    |    |    |    | User ID              |    |    |    |    |    |    |    |
|              | User ID, continued                       |   |   |   |   |   |   |   |                    |   |    |    |    |    |    |    |    |    |    |    |    |    |    |    |                      |    |    |    |    |    |    |    |
|              | Application Protocol ID, continued       |   |   |   |   |   |   |   |                    |   |    |    |    |    |    |    |    |    |    |    |    |    |    |    | Application Prot. ID |    |    |    |    |    |    |    |
|              | Application Protocol ID, continued       |   |   |   |   |   |   |   |                    |   |    |    |    |    |    |    |    |    |    |    |    |    |    |    |                      |    |    |    |    |    |    |    |
|              | URL Category, continued                  |   |   |   |   |   |   |   |                    |   |    |    |    |    |    |    |    |    |    |    |    |    |    |    | URL Category         |    |    |    |    |    |    |    |
|              | URL Category, continued                  |   |   |   |   |   |   |   |                    |   |    |    |    |    |    |    |    |    |    |    |    |    |    |    |                      |    |    |    |    |    |    |    |
|              | URL Reputation, continued                |   |   |   |   |   |   |   |                    |   |    |    |    |    |    |    |    |    |    |    |    |    |    |    | URL Reputation       |    |    |    |    |    |    |    |
|              | URL Reputation, continued                |   |   |   |   |   |   |   |                    |   |    |    |    |    |    |    |    |    |    |    |    |    |    |    |                      |    |    |    |    |    |    |    |
|              | Client Application ID, continued         |   |   |   |   |   |   |   |                    |   |    |    |    |    |    |    |    |    |    |    |    |    |    |    | Client App ID        |    |    |    |    |    |    |    |
|              | Client Application ID, continued         |   |   |   |   |   |   |   |                    |   |    |    |    |    |    |    |    |    |    |    |    |    |    |    |                      |    |    |    |    |    |    |    |
| Client URL   | Web Application ID, continued            |   |   |   |   |   |   |   |                    |   |    |    |    |    |    |    |    |    |    |    |    |    |    |    | Web App ID           |    |    |    |    |    |    |    |
|              | String Block Type, continued             |   |   |   |   |   |   |   |                    |   |    |    |    |    |    |    |    |    |    |    |    |    |    |    | Str. Block Type (0)  |    |    |    |    |    |    |    |
|              | String Block Length, continued           |   |   |   |   |   |   |   |                    |   |    |    |    |    |    |    |    |    |    |    |    |    |    |    | String Block Length  |    |    |    |    |    |    |    |
| NetBIOS Name | String Block Length, continued           |   |   |   |   |   |   |   |                    |   |    |    |    |    |    |    |    |    |    |    |    |    |    |    |                      |    |    |    |    |    |    |    |
|              | String Block Type (0)                    |   |   |   |   |   |   |   |                    |   |    |    |    |    |    |    |    |    |    |    |    |    |    |    |                      |    |    |    |    |    |    |    |
|              | String Block Length                      |   |   |   |   |   |   |   |                    |   |    |    |    |    |    |    |    |    |    |    |    |    |    |    |                      |    |    |    |    |    |    |    |
|              | NetBIOS Name...                          |   |   |   |   |   |   |   |                    |   |    |    |    |    |    |    |    |    |    |    |    |    |    |    |                      |    |    |    |    |    |    |    |

| Byte                          | 0                             |   |   |   |   |   |   |                 | 1 |   |    |    |    |    |    |                   | 2  |    |    |    |    |    |    |                  | 3  |    |    |    |    |    |    |    |
|-------------------------------|-------------------------------|---|---|---|---|---|---|-----------------|---|---|----|----|----|----|----|-------------------|----|----|----|----|----|----|----|------------------|----|----|----|----|----|----|----|----|
|                               | 0                             | 1 | 2 | 3 | 4 | 5 | 6 | 7               | 8 | 9 | 10 | 11 | 12 | 13 | 14 | 15                | 16 | 17 | 18 | 19 | 20 | 21 | 22 | 23               | 24 | 25 | 26 | 27 | 28 | 29 | 30 | 31 |
| Client App Version            | String Block Type (0)         |   |   |   |   |   |   |                 |   |   |    |    |    |    |    |                   |    |    |    |    |    |    |    |                  |    |    |    |    |    |    |    |    |
|                               | String Block Length           |   |   |   |   |   |   |                 |   |   |    |    |    |    |    |                   |    |    |    |    |    |    |    |                  |    |    |    |    |    |    |    |    |
|                               | Client Application Version... |   |   |   |   |   |   |                 |   |   |    |    |    |    |    |                   |    |    |    |    |    |    |    |                  |    |    |    |    |    |    |    |    |
| Monitor Rule 1                |                               |   |   |   |   |   |   |                 |   |   |    |    |    |    |    |                   |    |    |    |    |    |    |    |                  |    |    |    |    |    |    |    |    |
| Monitor Rule 2                |                               |   |   |   |   |   |   |                 |   |   |    |    |    |    |    |                   |    |    |    |    |    |    |    |                  |    |    |    |    |    |    |    |    |
| Monitor Rule 3                |                               |   |   |   |   |   |   |                 |   |   |    |    |    |    |    |                   |    |    |    |    |    |    |    |                  |    |    |    |    |    |    |    |    |
| Monitor Rule 4                |                               |   |   |   |   |   |   |                 |   |   |    |    |    |    |    |                   |    |    |    |    |    |    |    |                  |    |    |    |    |    |    |    |    |
| Monitor Rule 5                |                               |   |   |   |   |   |   |                 |   |   |    |    |    |    |    |                   |    |    |    |    |    |    |    |                  |    |    |    |    |    |    |    |    |
| Monitor Rule 6                |                               |   |   |   |   |   |   |                 |   |   |    |    |    |    |    |                   |    |    |    |    |    |    |    |                  |    |    |    |    |    |    |    |    |
| Monitor Rule 7                |                               |   |   |   |   |   |   |                 |   |   |    |    |    |    |    |                   |    |    |    |    |    |    |    |                  |    |    |    |    |    |    |    |    |
| Monitor Rule 8                |                               |   |   |   |   |   |   |                 |   |   |    |    |    |    |    |                   |    |    |    |    |    |    |    |                  |    |    |    |    |    |    |    |    |
| Sec. Int. Src/Dst             |                               |   |   |   |   |   |   | Sec. Int. Layer |   |   |    |    |    |    |    | File Event Count  |    |    |    |    |    |    |    |                  |    |    |    |    |    |    |    |    |
| Intrusion Event Count         |                               |   |   |   |   |   |   |                 |   |   |    |    |    |    |    | Initiator Country |    |    |    |    |    |    |    |                  |    |    |    |    |    |    |    |    |
| Responder Country             |                               |   |   |   |   |   |   |                 |   |   |    |    |    |    |    | IOC Number        |    |    |    |    |    |    |    |                  |    |    |    |    |    |    |    |    |
| Source Autonomous System      |                               |   |   |   |   |   |   |                 |   |   |    |    |    |    |    |                   |    |    |    |    |    |    |    |                  |    |    |    |    |    |    |    |    |
| Destination Autonomous System |                               |   |   |   |   |   |   |                 |   |   |    |    |    |    |    |                   |    |    |    |    |    |    |    |                  |    |    |    |    |    |    |    |    |
| SNMP In                       |                               |   |   |   |   |   |   |                 |   |   |    |    |    |    |    | SNMP Out          |    |    |    |    |    |    |    |                  |    |    |    |    |    |    |    |    |
| Source TOS                    |                               |   |   |   |   |   |   | Destination TOS |   |   |    |    |    |    |    | Source Mask       |    |    |    |    |    |    |    | Destination Mask |    |    |    |    |    |    |    |    |
| Security Context              |                               |   |   |   |   |   |   |                 |   |   |    |    |    |    |    |                   |    |    |    |    |    |    |    |                  |    |    |    |    |    |    |    |    |
| Security Context, continued   |                               |   |   |   |   |   |   |                 |   |   |    |    |    |    |    |                   |    |    |    |    |    |    |    |                  |    |    |    |    |    |    |    |    |
| Security Context, continued   |                               |   |   |   |   |   |   |                 |   |   |    |    |    |    |    |                   |    |    |    |    |    |    |    |                  |    |    |    |    |    |    |    |    |
| Security Context, continued   |                               |   |   |   |   |   |   |                 |   |   |    |    |    |    |    |                   |    |    |    |    |    |    |    |                  |    |    |    |    |    |    |    |    |

The following table describes the fields of the Connection Statistics data block for 5.3.1+.

**Table 4-68** *Connection Statistics Data Block 5.3.1+ Fields*

| Field                                   | Data Type | Description  |
|---|-----------|--|
| Connection Statistics Data Block Type   | uint32    | Initiates a Connection Statistics data block for 5.3.1+. The value is always 154.  |
| Connection Statistics Data Block Length | uint32    | Number of bytes in the Connection Statistics data block, including eight bytes for the connection statistics block type and length fields, plus the number of bytes in the connection data that follows. |
| Device ID                               | uint32    | The device that detected the connection event.   |
| Ingress Zone                            | uint8[16] | Ingress security zone in the event that triggered the policy violation.  |
| Egress Zone                             | uint8[16] | Egress security zone in the event that triggered the policy violation.   |
| Ingress Interface                       | uint8[16] | Interface for the inbound traffic.   |
| Egress Interface                        | uint8[16] | Interface for the outbound traffic.  |
| Initiator IP Address                    | uint8[16] | IP address of the host that initiated the session described in the connection event, in IP address octets.   |
| Responder IP Address                    | uint8[16] | IP address of the host that responded to the initiating host, in IP address octets.  |
| Policy Revision                         | uint8[16] | Revision number of the rule associated with the triggered correlation event, if applicable.  |
| Rule ID                                 | uint32    | Internal identifier for the rule that triggered the event, if applicable.  |
| Rule Action                             | uint16    | The action selected in the user interface for that rule (allow, block, and so forth).  |
| Rule Reason                             | uint16    | The reason the rule triggered the event.   |
| Initiator Port                          | uint16    | Port used by the initiating host.  |
| Responder Port                          | uint16    | Port used by the responding host.  |
| TCP Flags                               | uint16    | Indicates any TCP flags for the connection event.  |
| Protocol                                | uint8     | The IANA-specified protocol number.  |
| NetFlow Source                          | uint8[16] | IP address of the NetFlow-enabled device that exported the data for the connection.  |
| Instance ID                             | uint16    | Numerical ID of the Snort instance on the managed device that generated the event.   |
| Connection Counter                      | uint16    | Value used to distinguish between connection events that happen during the same second.  |
| First Packet Timestamp                  | uint32    | UNIX timestamp of the date and time the first packet was exchanged in the session.   |
| Last Packet Timestamp                   | uint32    | UNIX timestamp of the date and time the last packet was exchanged in the session.  |

Table 4-68 Connection Statistics Data Block 5.3.1+ Fields (continued)

| Field                         | Data Type | Description  |
|-------------------------------|-----------|--|
| Initiator Transmitted Packets | uint64    | Number of packets transmitted by the initiating host.  |
| Responder Transmitted Packets | uint64    | Number of packets transmitted by the responding host.  |
| Initiator Transmitted Bytes   | uint64    | Number of bytes transmitted by the initiating host.  |
| Responder Transmitted Bytes   | uint64    | Number of bytes transmitted by the responding host.  |
| User ID                       | uint32    | Internal identification number for the user who last logged into the host that generated the traffic.  |
| Application Protocol ID       | uint32    | Application ID of the application protocol.  |
| URL Category                  | uint32    | The internal identification number of the URL category.  |
| URL Reputation                | uint32    | The internal identification number for the URL reputation.   |
| Client Application ID         | uint32    | The internal identification number of the detected client application, if applicable.  |
| Web Application ID            | uint32    | The internal identification number of the detected web application, if applicable.   |
| String Block Type             | uint32    | Initiates a String data block for the client application URL. This value is always 0.  |
| String Block Length           | uint32    | Number of bytes in the client application URL String data block, including eight bytes for the string block type and length fields, plus the number of bytes in the client application URL string. |
| Client Application URL        | string    | URL the client application accessed, if applicable (/files/index.html, for example).   |
| String Block Type             | uint32    | Initiates a String data block for the host NetBIOS name. This value is always 0.   |
| String Block Length           | uint32    | Number of bytes in the String data block, including eight bytes for the string block type and length fields, plus the number of bytes in the NetBIOS name string.                                  |
| NetBIOS Name                  | string    | Host NetBIOS name string.  |
| String Block Type             | uint32    | Initiates a String data block for the client application version. This value is always 0.  |
| String Block Length           | uint32    | Number of bytes in the String data block for the client application version, including eight bytes for the string block type and length, plus the number of bytes in the version.                  |
| Client Application Version    | string    | Client application version.  |



Table 4-68 Connection Statistics Data Block 5.3.1+ Fields (continued)

| Field                                    | Data Type | Description  |
|--|-----------|--|
| Monitor Rule 1                           | uint32    | The ID of the first monitor rule associated with the connection event.                 |
| Monitor Rule 2                           | uint32    | The ID of the second monitor rule associated with the connection event.                |
| Monitor Rule 3                           | uint32    | The ID of the third monitor rule associated with the connection event.                 |
| Monitor Rule 4                           | uint32    | The ID of the fourth monitor rule associated with the connection event.                |
| Monitor Rule 5                           | uint32    | The ID of the fifth monitor rule associated with the connection event.                 |
| Monitor Rule 6                           | uint32    | The ID of the sixth monitor rule associated with the connection event.                 |
| Monitor Rule 7                           | uint32    | The ID of the seventh monitor rule associated with the connection event.               |
| Monitor Rule 8                           | uint32    | The ID of the eighth monitor rule associated with the connection event.                |
| Security Intelligence Source/Destination | uint8     | Whether the source or destination IP address matched the IP blacklist.                 |
| Security Intelligence Layer              | uint8     | The IP layer that matched the IP blacklist.  |
| File Event Count                         | uint16    | Value used to distinguish between file events that happen during the same second.      |
| Intrusion Event Count                    | uint16    | Value used to distinguish between intrusion events that happen during the same second. |
| Initiator Country                        | uint16    | Code for the country of the initiating host.   |
| Responder Country                        | uint16    | Code for the country of the responding host.   |
| IOC Number                               | uint16    | ID Number of the compromise associated with this event.                                |
| Source Autonomous System                 | uint32    | Autonomous system number of the source, either origin or peer.                         |
| Destination Autonomous System            | uint32    | Autonomous system number of the destination, either origin or peer.                    |
| SNMP Input                               | uint16    | SNMP index of the input interface.   |
| SNMP Output                              | uint16    | SNMP index of the output interface.  |
| Source TOS                               | uint8     | Type of Service byte setting for the incoming interface.                               |
| Destination TOS                          | uint8     | Type of Service byte setting for the outgoing interface.                               |
| Source Mask                              | uint8     | Source address prefix mask.  |

Table 4-68 Connection Statistics Data Block 5.3.1+ Fields (continued)

| Field            | Data Type | Description  |
|------------------|-----------|--|
| Destination Mask | uint8     | Destination address prefix mask.   |
| Security Context | uint8(16) | ID number for the security context (virtual firewall) that the traffic passed through. Note that the system only populates this field for ASA FirePOWER devices in multi-context mode. |

## Scan Result Data Block 5.2+

The Scan Result data block describes a vulnerability and is used within Add Scan Result events (event type 1002, subtype 11). The Scan Result data block has a block type of 142 in the series 1 group of blocks. It supersedes block type 102. The IP address field was increased to 16 bytes for version 5.2.

The following diagram shows the format of a Scan Result data block:

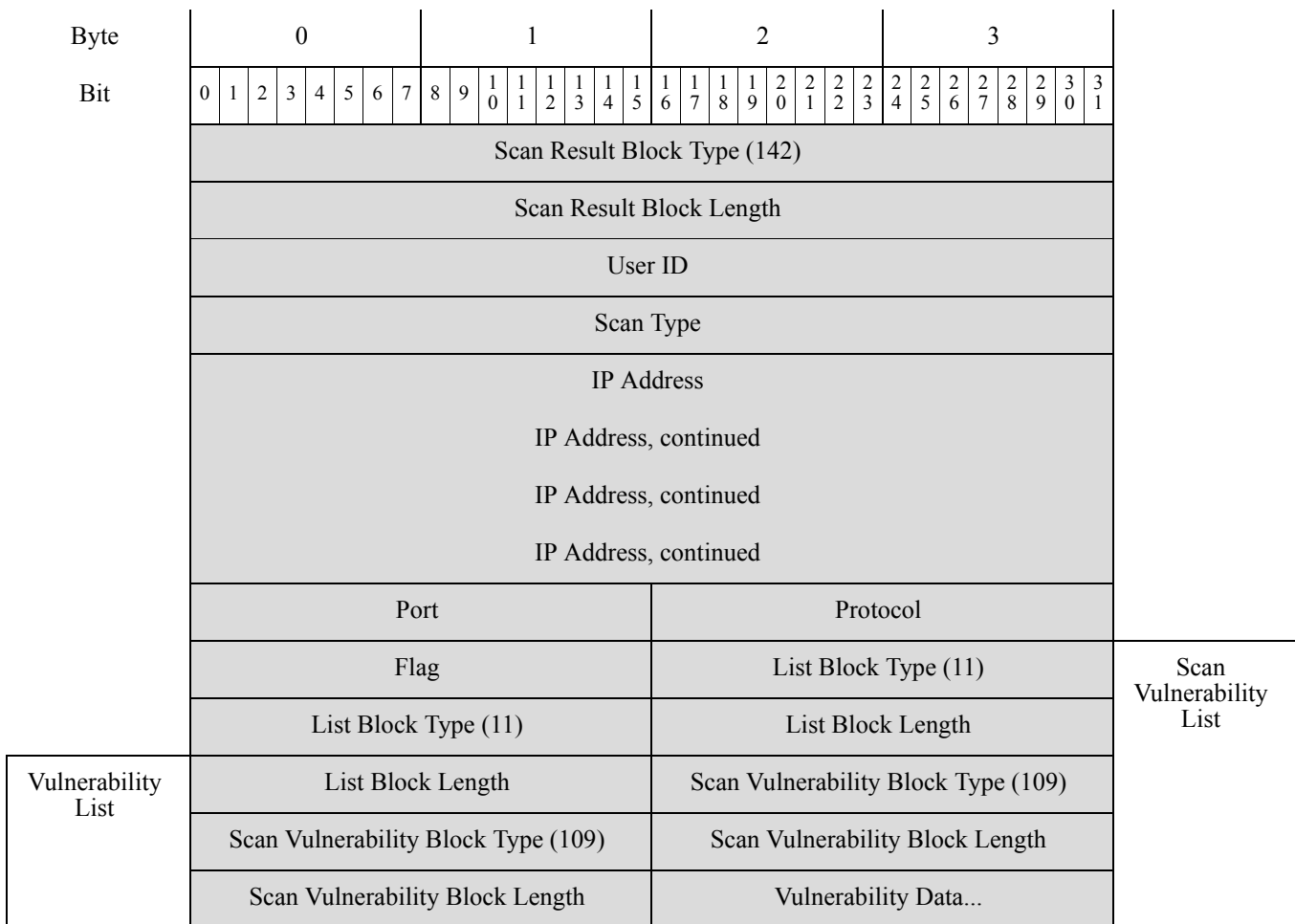

| Byte              | 0                                     |   |   |   |   |   |   |   | 1 |   |    |    |    |    |    |    | 2  |    |    |    |    |    |    |    | 3  |    |    |    |    |    |    |                           |  |
|-------------------|---------------------------------------|---|---|---|---|---|---|---|---|---|----|----|----|----|----|----|----|----|----|----|----|----|----|----|----|----|----|----|----|----|----|---------------------------|--|
| Bit               | 0                                     | 1 | 2 | 3 | 4 | 5 | 6 | 7 | 8 | 9 | 10 | 11 | 12 | 13 | 14 | 15 | 16 | 17 | 18 | 19 | 20 | 21 | 22 | 23 | 24 | 25 | 26 | 27 | 28 | 29 | 30 | 31                        |  |
|                   | List Block Type (11)                  |   |   |   |   |   |   |   |   |   |    |    |    |    |    |    |    |    |    |    |    |    |    |    |    |    |    |    |    |    |    | Generic Scan Results List |  |
|                   | List Block Length                     |   |   |   |   |   |   |   |   |   |    |    |    |    |    |    |    |    |    |    |    |    |    |    |    |    |    |    |    |    |    |                           |  |
| Scan Results List | Generic Scan Results Block Type (108) |   |   |   |   |   |   |   |   |   |    |    |    |    |    |    |    |    |    |    |    |    |    |    |    |    |    |    |    |    |    |                           |  |
|                   | Generic Scan Results Block Length     |   |   |   |   |   |   |   |   |   |    |    |    |    |    |    |    |    |    |    |    |    |    |    |    |    |    |    |    |    |    |                           |  |
|                   | Generic Scan Results...               |   |   |   |   |   |   |   |   |   |    |    |    |    |    |    |    |    |    |    |    |    |    |    |    |    |    |    |    |    |    |                           |  |
| User Product List | Generic List Block Type (31)          |   |   |   |   |   |   |   |   |   |    |    |    |    |    |    |    |    |    |    |    |    |    |    |    |    |    |    |    |    |    |                           |  |
|                   | Generic List Block Length             |   |   |   |   |   |   |   |   |   |    |    |    |    |    |    |    |    |    |    |    |    |    |    |    |    |    |    |    |    |    |                           |  |
|                   | User Product Data Blocks*             |   |   |   |   |   |   |   |   |   |    |    |    |    |    |    |    |    |    |    |    |    |    |    |    |    |    |    |    |    |    |                           |  |

The following table describes the fields of the Scan Result data block.

**Table 4-69** Scan Result Data Block Fields

| Field                    | Data Type | Description   |
|--------------------------|-----------|---|
| Scan Result Block Type   | uint32    | Initiates a Scan Result data block. This value is always 142.   |
| Scan Result Block Length | uint32    | Number of bytes in the Scan Vulnerability data block, including eight bytes for the scan vulnerability block type and length fields, plus the number of bytes of scan vulnerability data that follows.  |
| User ID                  | uint32    | Contains the user identification number for the user who imported the scan result or ran the scan that produced the scan result.  |
| Scan Type                | uint32    | Indicates how the results were added to the system.   |
| IP Address               | uint8[16] | IP address of the host affected by the vulnerabilities in the result, in IP address octets.   |
| Port                     | uint16    | Port used by the sub-server affected by the vulnerabilities in the results.   |
| Protocol                 | uint16    | IANA protocol number or Ethertype. This is handled differently for Transport and Network layer protocols.<br>Transport layer protocols are identified by the IANA protocol number. For example: <ul style="list-style-type: none"> <li>6 - TCP</li> <li>17 - UDP</li> </ul> Network layer protocols are identified by the decimal form of the IEEE Registration Authority Ethertype. For example: <ul style="list-style-type: none"> <li>2048 - IP</li> </ul> |
| Flag                     | uint16    | Reserved  |

Table 4-69 Scan Result Data Block Fields (continued)

| Field                             | Data Type | Description   |
|-----------------------------------|-----------|---|
| List Block Type                   | uint32    | Initiates a List data block comprising Scan Vulnerability data blocks conveying transport Scan Vulnerability data. This value is always 11.   |
| List Block Length                 | uint32    | Number of bytes in the list. This number includes the eight bytes of the list block type and length fields, plus all encapsulated Scan Vulnerability data blocks.<br><br>This field is followed by zero or more Scan Vulnerability data blocks. |
| Scan Vulnerability Block Type     | uint32    | Initiates a Scan Vulnerability data block describing a vulnerability detected during a scan. This value is always 109.  |
| Scan Vulnerability Block Length   | uint32    | Number of bytes in the Scan Vulnerability data block, including eight bytes for the scan vulnerability block type and length fields, plus the number of bytes in the scan vulnerability data that follows.                                      |
| Vulnerability Data                | string    | Information relating to each vulnerability.   |
| List Block Type                   | uint32    | Initiates a List data block comprising Scan Vulnerability data blocks conveying transport Scan Vulnerability data. This value is always 11.   |
| List Block Length                 | uint32    | Number of bytes in the list. This number includes the eight bytes of the list block type and length fields, plus all encapsulated Scan Vulnerability data blocks.<br><br>This field is followed by zero or more Scan Vulnerability data blocks. |
| Generic Scan Results Block Type   | uint32    | Initiates a Generic Scan Results data block describing server and operating system data detected during a scan. This value is always 108.   |
| Generic Scan Results Block Length | uint32    | Number of bytes in the Generic Scan Results data block, including eight bytes for the generic scan results block type and length fields, plus the number of bytes in the scan result data that follows.   |
| Generic Scan Results Data         | string    | Information relating to each scan result.   |
| Generic List Block Type           | uint32    | Initiates a Generic List data block comprising User Product data blocks conveying host input data from a third-party application. This value is always 31.  |
| Generic List Block Length         | uint32    | Number of bytes in the Generic List data block, including the list header and all encapsulated User Product data blocks.  |
| User Product Data Blocks *        | variable  | User Product data blocks containing host input data. See <a href="#">User Product Data Block 5.1+</a> , page 4-152 for a description of this data block.  |

## Host Server Data Block 4.10.0+

The Host Server data block conveys information about the detected servers on a host. It contains a block for each detected server, and also includes a list of web application data blocks for the web applications the server is running. Host Server data blocks are contained in messages for new and changed TCP and UDP servers. For more information, see [Server Messages](#), page 4-38. The Host Server data block has a block type of 103 in the series 1 group of blocks.



**Note** An asterisk(\*) next to a data block name in the following diagram indicates that multiple instances of the data block may occur.

The following diagram shows the format of the Host Server data block:

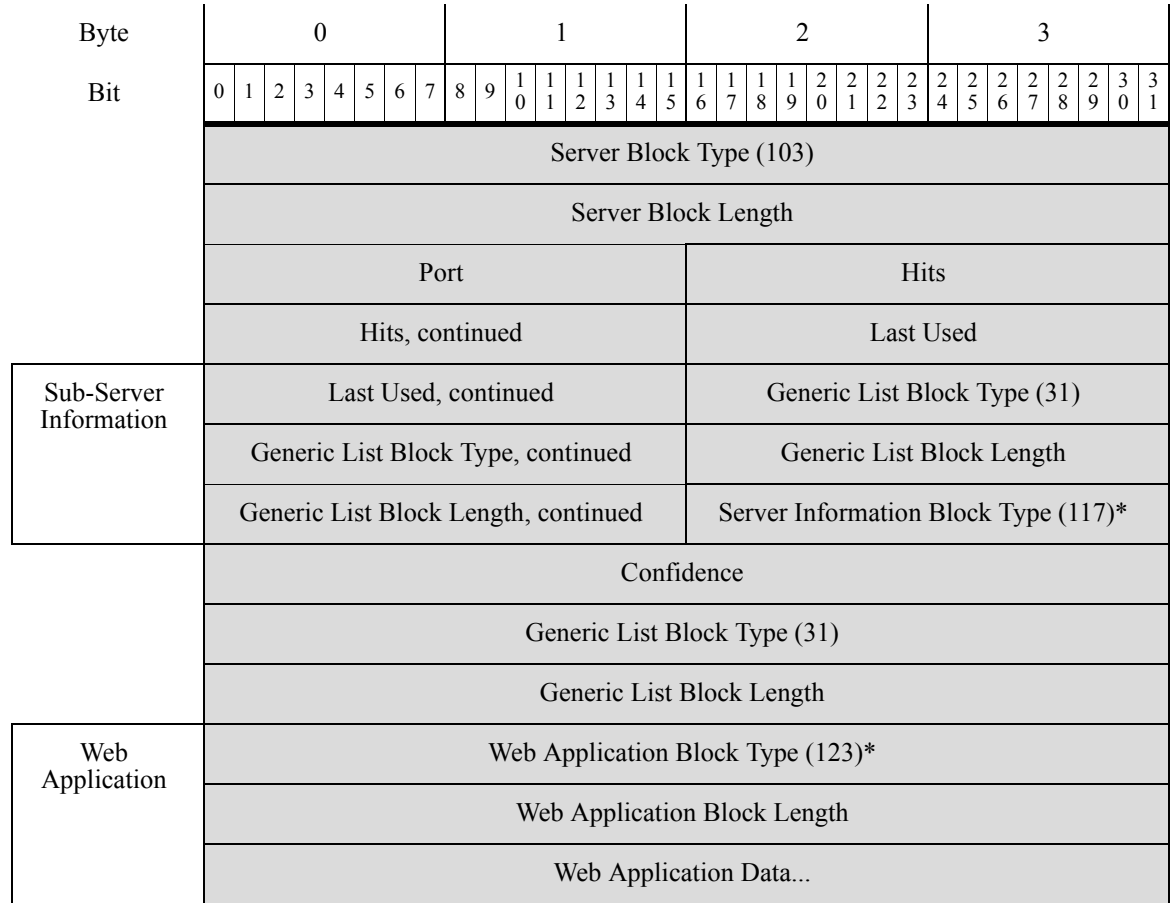

The following table describes the fields of the Host Server data block.

**Table 4-70** Host Server Data Block Fields

| Field                    | Data Type | Description  |
|--------------------------|-----------|--|
| Host Server Block Type   | uint32    | Initiates a Host Server data block. This value is always 103.  |
| Host Server Block Length | uint32    | Total number of bytes in the Host Server data block, including the eight bytes in the Host Server block type and length fields, plus the number of bytes of data that follows. |
| Port                     | uint16    | Port number where the server runs.   |
| Hits                     | uint32    | Number of hits the server has received.  |
| Last Used                | uint32    | UNIX timestamp that represents the last time the system detected the server in use.  |

Table 4-70 Host Server Data Block Fields (continued)

| Field                           | Data Type | Description   |
|---------------------------------|-----------|---|
| Generic List Block Type         | uint32    | Initiates a Generic List data block. This value is always 31.   |
| Generic List Block Length       | uint32    | Number of bytes in the Generic List block and encapsulated sub-server information data blocks. This number includes the eight bytes of the generic list block header fields, plus the number of bytes in all of the encapsulated data blocks.     |
| Server Information Data Blocks* | variable  | Server information data blocks up to the maximum number of bytes in the list block length. For details, see <a href="#">Server Information Data Block for 4.10.x, 5.0 - 5.0.2, page 4-126</a> .   |
| Confidence                      | uint32    | Confidence percentage.  |
| Generic List Block Type         | uint32    | Initiates a Generic data block. This value is always 31.  |
| Generic List Block Length       | uint32    | Number of bytes in the Generic block and encapsulated web application data blocks. This number includes the eight bytes of the generic list block header fields, plus the number of bytes in all of the encapsulated web application data blocks. |
| Web Application Data Blocks*    | variable  | Encapsulated web application data blocks up to the maximum number of bytes in the list block length. For details, see <a href="#">Web Application Data Block for 5.0+, page 4-110</a> .   |

## Full Host Server Data Block 4.10.0+

The Full Host Server data block conveys information about a server, including the server port, the frequency of use and most recent update, confidence of data accuracy, and Cisco and third-party vulnerabilities related to that server for the host. The Full Host Server data block contains a Full Sub-Server Information data block for each sub-server on the server. Each Full Host Profile data block contains a Full Host Server data block for each TCP and UDP server on the host. The Full Host Server data block has a block type of 104 in the series 1 group of blocks.



### Note

An asterisk(\*) next to a series 1 data block name in the following diagram indicates that multiple instances of the data block may occur.

The following diagram shows the format of the Full Server data block:

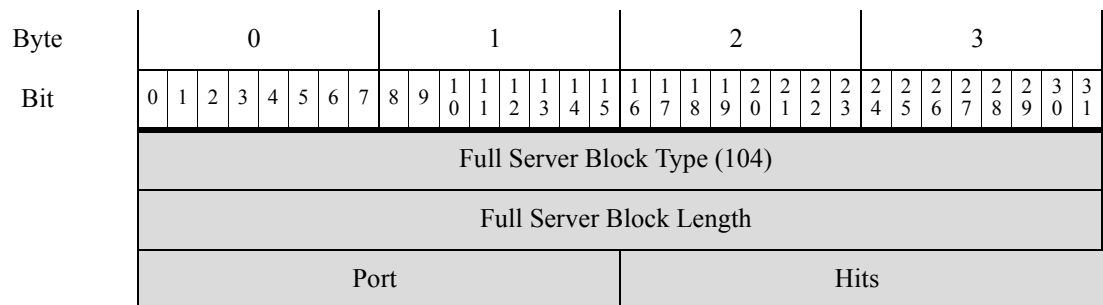

| Byte                         | 0  |   |   |   |   |   |   |   | 1 |   |    |    |    |    |    |    | 2  |    |    |    |    |    |    |    | 3  |    |    |    |    |    |    |    |
|------------------------------|--|---|---|---|---|---|---|---|---|---|----|----|----|----|----|----|--|----|----|----|----|----|----|----|----|----|----|----|----|----|----|----|
|                              | 0  | 1 | 2 | 3 | 4 | 5 | 6 | 7 | 8 | 9 | 10 | 11 | 12 | 13 | 14 | 15 | 16   | 17 | 18 | 19 | 20 | 21 | 22 | 23 | 24 | 25 | 26 | 27 | 28 | 29 | 30 | 31 |
| Sub-Servers - Cisco          | Hits, continued  |   |   |   |   |   |   |   |   |   |    |    |    |    |    |    | Generic List Block Type (31)               |    |    |    |    |    |    |    |    |    |    |    |    |    |    |    |
|                              | Generic List Block Type, continued                     |   |   |   |   |   |   |   |   |   |    |    |    |    |    |    | Generic List Block Length                  |    |    |    |    |    |    |    |    |    |    |    |    |    |    |    |
|                              | Generic List Block Length, continued                   |   |   |   |   |   |   |   |   |   |    |    |    |    |    |    | Full Server Information Data Blocks (106)* |    |    |    |    |    |    |    |    |    |    |    |    |    |    |    |
| Sub-Servers - User           | Generic List Block Type (31)                           |   |   |   |   |   |   |   |   |   |    |    |    |    |    |    |  |    |    |    |    |    |    |    |    |    |    |    |    |    |    |    |
|                              | Generic List Block Length                              |   |   |   |   |   |   |   |   |   |    |    |    |    |    |    |  |    |    |    |    |    |    |    |    |    |    |    |    |    |    |    |
|                              | Full Server Information Data Block Type (106)*         |   |   |   |   |   |   |   |   |   |    |    |    |    |    |    |  |    |    |    |    |    |    |    |    |    |    |    |    |    |    |    |
| Sub-Servers - Scanner        | Generic List Block Type (31)                           |   |   |   |   |   |   |   |   |   |    |    |    |    |    |    |  |    |    |    |    |    |    |    |    |    |    |    |    |    |    |    |
|                              | Generic List Block Length                              |   |   |   |   |   |   |   |   |   |    |    |    |    |    |    |  |    |    |    |    |    |    |    |    |    |    |    |    |    |    |    |
|                              | Full Server Information Data Blocks (106)*             |   |   |   |   |   |   |   |   |   |    |    |    |    |    |    |  |    |    |    |    |    |    |    |    |    |    |    |    |    |    |    |
| Sub-Servers - Application    | Generic List Block Type (31)                           |   |   |   |   |   |   |   |   |   |    |    |    |    |    |    |  |    |    |    |    |    |    |    |    |    |    |    |    |    |    |    |
|                              | Generic List Block Length                              |   |   |   |   |   |   |   |   |   |    |    |    |    |    |    |  |    |    |    |    |    |    |    |    |    |    |    |    |    |    |    |
|                              | Full Server Information Data Blocks (106)*             |   |   |   |   |   |   |   |   |   |    |    |    |    |    |    |  |    |    |    |    |    |    |    |    |    |    |    |    |    |    |    |
|                              | Confidence   |   |   |   |   |   |   |   |   |   |    |    |    |    |    |    |  |    |    |    |    |    |    |    |    |    |    |    |    |    |    |    |
| Server Banner                | BLOB Block Type (10)                                   |   |   |   |   |   |   |   |   |   |    |    |    |    |    |    |  |    |    |    |    |    |    |    |    |    |    |    |    |    |    |    |
|                              | BLOB Block Length                                      |   |   |   |   |   |   |   |   |   |    |    |    |    |    |    |  |    |    |    |    |    |    |    |    |    |    |    |    |    |    |    |
|                              | Server Banner Data...                                  |   |   |   |   |   |   |   |   |   |    |    |    |    |    |    |  |    |    |    |    |    |    |    |    |    |    |    |    |    |    |    |
| VDB Vulnerability            | Generic List Block Type (31)                           |   |   |   |   |   |   |   |   |   |    |    |    |    |    |    |  |    |    |    |    |    |    |    |    |    |    |    |    |    |    |    |
|                              | Generic List Block Length                              |   |   |   |   |   |   |   |   |   |    |    |    |    |    |    |  |    |    |    |    |    |    |    |    |    |    |    |    |    |    |    |
|                              | (VDB) Host Vulnerability Data Blocks (85)*             |   |   |   |   |   |   |   |   |   |    |    |    |    |    |    |  |    |    |    |    |    |    |    |    |    |    |    |    |    |    |    |
| Third Pty/VDB Vulnerability  | Generic List Block Type (31)                           |   |   |   |   |   |   |   |   |   |    |    |    |    |    |    |  |    |    |    |    |    |    |    |    |    |    |    |    |    |    |    |
|                              | Generic List Block Length                              |   |   |   |   |   |   |   |   |   |    |    |    |    |    |    |  |    |    |    |    |    |    |    |    |    |    |    |    |    |    |    |
|                              | (Third Party/VDB) Host Vulnerability Data Blocks (85)* |   |   |   |   |   |   |   |   |   |    |    |    |    |    |    |  |    |    |    |    |    |    |    |    |    |    |    |    |    |    |    |
| Third Pty Host Vulnerability | Generic List Block Type (31)                           |   |   |   |   |   |   |   |   |   |    |    |    |    |    |    |  |    |    |    |    |    |    |    |    |    |    |    |    |    |    |    |
|                              | Generic List Block Length                              |   |   |   |   |   |   |   |   |   |    |    |    |    |    |    |  |    |    |    |    |    |    |    |    |    |    |    |    |    |    |    |
|                              | (Third Party) Host Vulnerability Data Blocks (85)*     |   |   |   |   |   |   |   |   |   |    |    |    |    |    |    |  |    |    |    |    |    |    |    |    |    |    |    |    |    |    |    |

|                 |                              |   |   |   |   |   |   |   |   |   |    |    |    |    |    |    |    |    |    |    |    |    |    |    |    |    |    |    |    |    |    |    |
|-----------------|------------------------------|---|---|---|---|---|---|---|---|---|----|----|----|----|----|----|----|----|----|----|----|----|----|----|----|----|----|----|----|----|----|----|
| Byte            | 0                            |   |   |   |   |   |   |   | 1 |   |    |    |    |    |    |    | 2  |    |    |    |    |    |    |    | 3  |    |    |    |    |    |    |    |
| Bit             | 0                            | 1 | 2 | 3 | 4 | 5 | 6 | 7 | 8 | 9 | 10 | 11 | 12 | 13 | 14 | 15 | 16 | 17 | 18 | 19 | 20 | 21 | 22 | 23 | 24 | 25 | 26 | 27 | 28 | 29 | 30 | 31 |
| Web Application | Generic List Block Type (31) |   |   |   |   |   |   |   |   |   |    |    |    |    |    |    |    |    |    |    |    |    |    |    |    |    |    |    |    |    |    |    |
|                 | Generic List Block Length    |   |   |   |   |   |   |   |   |   |    |    |    |    |    |    |    |    |    |    |    |    |    |    |    |    |    |    |    |    |    |    |
|                 | Web Application Data (123)*  |   |   |   |   |   |   |   |   |   |    |    |    |    |    |    |    |    |    |    |    |    |    |    |    |    |    |    |    |    |    |    |

The following table describes the components of the Full Server data block.

Table 4-71 Full Server Data Block 4.10.0+ Fields

| Field  | Data Type | Description  |
|--|-----------|--|
| Full Server Block Type                           | uint32    | Initiates a Full Server data block. This value is always 104.  |
| Full Server Block Length                         | uint32    | Total number of bytes in the Full Server data block, including eight bytes for the full server block type and length fields, plus the number of bytes of full server data that follows.                                    |
| Port   | uint16    | Server port number.  |
| Hits   | uint32    | Number of hits the server has received.  |
| Generic List Block Type                          | uint32    | Initiates a Generic List data block comprising data blocks of detected sub-server data. This value is always 31.   |
| Generic List Block Length                        | uint32    | Number of bytes in the Generic List data block, including the list header and all encapsulated sub-server information data blocks.   |
| Sub-Server Information - Cisco Data Blocks *     | variable  | Full Server Information data blocks containing information about sub-servers for a host server detected by Cisco. See <a href="#">Full Server Information Data Block, page 4-128</a> for a description of this data block. |
| Generic List Block Type                          | uint32    | Initiates a Generic List data block comprising sub-server information data blocks conveying sub-server data added by a user. This value is always 31.  |
| Generic List Block Length                        | uint32    | Number of bytes in the Generic List data block, including the list header and all encapsulated server information data blocks.   |
| Sub-Server Information- User Added Data Blocks * | variable  | Full Server Information data blocks containing information about sub-servers on a host added by a user. See <a href="#">Full Server Information Data Block, page 4-128</a> for a description of this data block.           |
| Generic List Block Type                          | uint32    | Initiates a Generic List data block comprising sub-server information data blocks conveying sub-server data added by a scanner. This value is always 31.   |
| Generic List Block Length                        | uint32    | Number of bytes in the Generic List data block, including the list header and all encapsulated sub-server information data blocks.   |



Table 4-71 Full Server Data Block 4.10.0+ Fields (continued)

| Field  | Data Type        | Description   |
|--|------------------|---|
| Sub-Server Information- Scan Added Data Blocks *         | variable         | Full Server Information data blocks containing information about sub-servers on a host added by a scanner. See <a href="#">Full Server Information Data Block, page 4-128</a> for a description of this data block.   |
| Generic List Block Type                                  | uint32           | Initiates a Generic List data block comprising sub-server information data blocks conveying sub-server data added by an application. This value is always 31.   |
| Generic List Block Length                                | uint32           | Number of bytes in the Generic List data block, including the list header and all encapsulated sub-server information data blocks.  |
| Sub-Server Information - Application Added Data Blocks * | variable         | Full Server Information data blocks containing information about sub-servers on a host added by an application. See <a href="#">Full Server Information Data Block, page 4-128</a> for a description of this data block.  |
| Confidence   | uint32           | Percentage of confidence of Cisco in correct identification of the full server data.  |
| BLOB Block Type  | uint32           | Initiates a BLOB data block, which contains banner data. This value is always 10.   |
| BLOB Block Length  | uint32           | Total number of bytes in the BLOB data block, including eight bytes for the block type and length fields, plus the number of bytes in the banner.   |
| Server Banner Data                                       | byte[ <i>n</i> ] | First <i>n</i> bytes of the packet involved in the server event, where <i>n</i> is equal to or less than 256.   |
| Generic List Block Type                                  | uint32           | Initiates a Generic List data block comprising Host Vulnerability data blocks conveying Cisco vulnerability data. This value is always 31.  |
| Generic List Block Length                                | uint32           | Number of bytes in the Generic List data block, including the list header and all encapsulated Host Vulnerability data blocks.  |
| (VDB) Host Vulnerability Data Blocks *                   | variable         | Host Vulnerability data blocks containing information about host vulnerabilities in the vulnerability database (VDB). See <a href="#">Host Vulnerability Data Block 4.9.0+, page 4-105</a> for a description of this data block.  |
| Generic List Block Type                                  | uint32           | Initiates a Generic List data block comprising Host Vulnerability data blocks conveying third-party host vulnerability data sourced from a third-party scanner and containing vulnerability information already cataloged in the VDB. This value is always 31.                    |
| Generic List Block Length                                | uint32           | Number of bytes in the Generic List data block, including the list header and all encapsulated Host Vulnerability data blocks.  |
| (ThirdParty/VDB) Host Vulnerability Data Blocks *        | variable         | Host Vulnerability data blocks sourced from a third-party scanner and containing information about host vulnerabilities cataloged in the vulnerability database (VDB). See <a href="#">Host Vulnerability Data Block 4.9.0+, page 4-105</a> for a description of this data block. |

Table 4-71 Full Server Data Block 4.10.0+ Fields (continued)

| Field   | Data Type | Description   |
|---|-----------|---|
| Generic List Block Type                           | uint32    | Initiates a Generic List data block comprising Host Vulnerability data blocks conveying third-party host vulnerability data generated by a third-party scanner. This value is always 31.  |
| Generic List Block Length                         | uint32    | Number of bytes in the Generic List data block, including the list header and all encapsulated Host Vulnerability data blocks.  |
| Third Party Scan Host Vulnerability Data Blocks * | variable  | Host Vulnerability data blocks containing third-party vulnerability data for vulnerabilities identified by a third-party scanner but not cataloged in the VDB. See <a href="#">Host Vulnerability Data Block 4.9.0+, page 4-105</a> for a description of this data block. |
| Generic List Block Type                           | uint32    | Initiates a Generic List data block. This value is always 31.   |
| Generic List Block Length                         | uint32    | Number of bytes in the Generic List block and encapsulated Web Application data blocks. This number includes the eight bytes of the generic list block header fields, plus the number of bytes in all of the encapsulated data blocks.                                    |
| Web Application Data Blocks*                      | variable  | Encapsulated Web Application data blocks up to the maximum number of bytes in the list block length.  |

## Server Information Data Block for 4.10.x, 5.0 - 5.0.2

The Server Information data block conveys information about a server, including the server ID, server vendor and version, and source information. The Server Information data block has a block type of 105 in the series 1 group of blocks for 4.10.x and a block type of 117 in the series 1 group of blocks for 5.0 - 5.0.2. Server information data blocks are conveyed in lists within Host Server blocks and Full Host server data blocks. For more information see [Host Server Data Block 4.10.0+, page 4-120](#) and [Full Host Server Data Block 4.10.0+, page 4-122](#).

The following diagram shows the format of the Server Information data block:

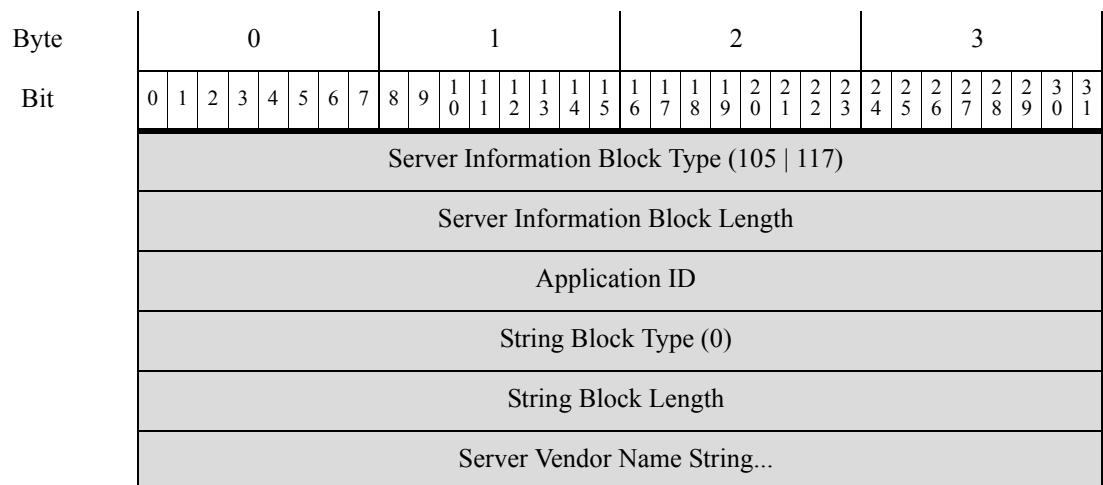

|             |                             |   |   |   |   |   |   |   |   |   |    |    |    |    |    |    |    |    |    |    |    |    |    |    |    |    |    |    |    |    |    |    |
|-------------|-----------------------------|---|---|---|---|---|---|---|---|---|----|----|----|----|----|----|----|----|----|----|----|----|----|----|----|----|----|----|----|----|----|----|
| Byte        | 0                           |   |   |   |   |   |   |   | 1 |   |    |    |    |    |    |    | 2  |    |    |    |    |    |    |    | 3  |    |    |    |    |    |    |    |
| Bit         | 0                           | 1 | 2 | 3 | 4 | 5 | 6 | 7 | 8 | 9 | 10 | 11 | 12 | 13 | 14 | 15 | 16 | 17 | 18 | 19 | 20 | 21 | 22 | 23 | 24 | 25 | 26 | 27 | 28 | 29 | 30 | 31 |
|             | String Block Type (0)       |   |   |   |   |   |   |   |   |   |    |    |    |    |    |    |    |    |    |    |    |    |    |    |    |    |    |    |    |    |    |    |
|             | String Block Length         |   |   |   |   |   |   |   |   |   |    |    |    |    |    |    |    |    |    |    |    |    |    |    |    |    |    |    |    |    |    |    |
|             | Server Version String...    |   |   |   |   |   |   |   |   |   |    |    |    |    |    |    |    |    |    |    |    |    |    |    |    |    |    |    |    |    |    |    |
|             | Last Used                   |   |   |   |   |   |   |   |   |   |    |    |    |    |    |    |    |    |    |    |    |    |    |    |    |    |    |    |    |    |    |    |
|             | Source Type                 |   |   |   |   |   |   |   |   |   |    |    |    |    |    |    |    |    |    |    |    |    |    |    |    |    |    |    |    |    |    |    |
|             | Source ID                   |   |   |   |   |   |   |   |   |   |    |    |    |    |    |    |    |    |    |    |    |    |    |    |    |    |    |    |    |    |    |    |
|             | List Block Type (11)        |   |   |   |   |   |   |   |   |   |    |    |    |    |    |    |    |    |    |    |    |    |    |    |    |    |    |    |    |    |    |    |
|             | List Block Length           |   |   |   |   |   |   |   |   |   |    |    |    |    |    |    |    |    |    |    |    |    |    |    |    |    |    |    |    |    |    |    |
| Sub-Servers | Sub-Server Block Type (1) * |   |   |   |   |   |   |   |   |   |    |    |    |    |    |    |    |    |    |    |    |    |    |    |    |    |    |    |    |    |    |    |
|             | Sub-Server Block Length     |   |   |   |   |   |   |   |   |   |    |    |    |    |    |    |    |    |    |    |    |    |    |    |    |    |    |    |    |    |    |    |
|             | Sub-Server Data...          |   |   |   |   |   |   |   |   |   |    |    |    |    |    |    |    |    |    |    |    |    |    |    |    |    |    |    |    |    |    |    |

The following table describes the components of the Server Information data block.

**Table 4-72** Server Information Data Block Fields

| Field                           | Data Type | Description  |
|---------------------------------|-----------|--|
| Server Information Block Type   | uint32    | Initiates a Server Information data block. The block type is 105 for 4.10.x and 117 for 5.0+.  |
| Server Information Block Length | uint32    | Total number of bytes in the Server Information data block, including eight bytes for the Server Information block type and length fields, four bytes for the server ID, eight bytes for the vendor name block type and length, another four for the vendor name, eight bytes for the version string block type and length, another four for the version string, and four bytes each for the last used, source type, and source ID fields. |
| Application ID                  | uint32    | The application ID for the application protocol running on the detected server.  |
| String Block Type               | uint32    | Initiates a String data block containing the server vendor's name. This value is always 0.   |
| String Block Length             | uint32    | Number of bytes in the vendor name String data block, including eight bytes for the block type and length fields, plus the number of bytes in the server vendor name.  |
| Server Vendor Name              | string    | Name of the server vendor.   |
| String Block Type               | uint32    | Initiates a String data block that contains the server version. This value is always 0.  |

Table 4-72 Server Information Data Block Fields (continued)

| Field                   | Data Type | Description  |
|-------------------------|-----------|--|
| String Block Length     | uint32    | Number of bytes in the server version String data block, including eight bytes for the block type and length fields, plus the number of bytes in the server version.   |
| Server Version          | string    | Server version.  |
| Last Time Used          | uint32    | Indicates when the server information was last used in traffic.  |
| Source Type             | uint32    | Number that maps to the type of data source: <ul style="list-style-type: none"> <li>• 0 if the server data was provided by RNA</li> <li>• 1 if the server data was provided by a user</li> <li>• 2 if the server data was provided by a third-party scanner</li> <li>• 3 if the server data was provided by a command line tool such as <code>nmimport.pl</code> or the Host Input API client</li> </ul> |
| Source ID               | uint32    | Identification number that maps to the source of the server data. Depending on the source type, this may map to RNA, a user, a scanner, or a third-party application.  |
| List Block Type         | uint32    | Initiates a list of Sub-Server data blocks. This value is always 11.   |
| List Block Length       | uint32    | Number of bytes in the List data block, including eight bytes for the list block type and length fields, plus the number of bytes in the encapsulated Sub-Server data blocks that follow.  |
| Sub-Server Block Type   | uint32    | Initiates the first Sub-Server data block. This data block can be followed by other Sub-Server data blocks up to the limit defined in the list block length field.   |
| Sub-Server Block Length | uint32    | Total number of bytes in each Sub-Server data block, including the eight bytes in the Sub-Server block type and length fields, plus the number of bytes of data that follows.  |
| Sub-Server Data         | variable  | Sub-server data as documented in <a href="#">Sub-Server Data Block, page 4-66</a> .  |

## Full Server Information Data Block

The Full Server Information data block conveys information about a server detected on a host, including the server's application protocol, vendor, and version, and the list of its associated sub-servers. For each sub-server, information is included by a Full Sub-Server data block (see [Full Sub-Server Data Block, page 4-77](#)). The Full Server Information data block has a block type of 106 in the series 1 group of blocks.



### Note

An asterisk(\*) next to a series 1 data block name in the following diagram indicates that multiple instances of the data block may occur.

The following diagram shows the format of the Full Server Information data block:

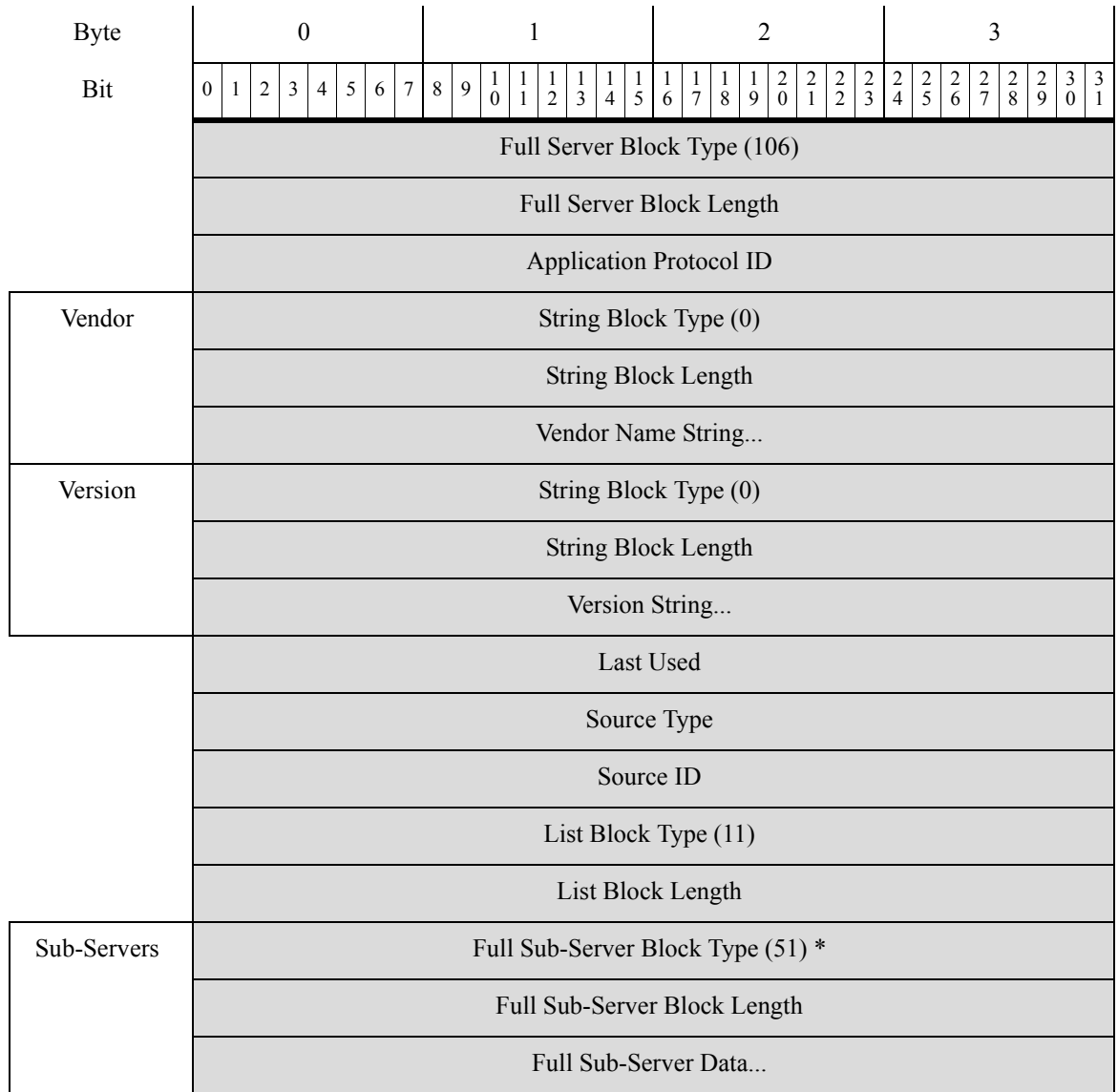

The following table describes the components of the Full Server Information data block.

**Table 4-73 Full Server Information Data Block Fields**

| Field                                | Data Type | Description   |
|--------------------------------------|-----------|---|
| Full Server Information Block Type   | uint32    | Initiates a Full Server Information data block. This value is always 106.   |
| Full Server Information Block Length | uint32    | Total number of bytes in the Full Server Information data block, including eight bytes for the full server block type and length fields, plus the number of bytes in the full server data that follows. |

Table 4-73 Full Server Information Data Block Fields (continued)

| Field                         | Data Type | Description  |
|-------------------------------|-----------|--|
| Application Protocol ID       | uint32    | The application ID of the application protocol running on the server.  |
| String Block Type             | uint32    | Initiates a String data block containing the application protocol vendor's name. This value is always 0.   |
| String Block Length           | uint32    | Number of bytes in the vendor name String data block, including eight bytes for the block type and length fields, plus the number of bytes in the vendor name.   |
| Vendor Name                   | string    | Name of the server vendor.   |
| String Block Type             | uint32    | Initiates a String data block that contains the application protocol version. This value is always 0.  |
| String Block Length           | uint32    | Number of bytes in the String data block, including eight bytes for the block type and length fields, plus the number of bytes in the version.   |
| Version                       | string    | The version of the server.   |
| Last Used                     | uint32    | UNIX timestamp that represents the last time the system detected the server in use.  |
| Source Type                   | uint32    | Number that maps to the type of data source: <ul style="list-style-type: none"> <li>0 if the server data was provided by RNA</li> <li>1 if the server data was provided by a user</li> <li>2 if the client data was provided by a third-party scanner</li> <li>3 if the server data was provided by a command line tool such as <code>nmimport.pl</code> or the Host Input API client</li> </ul> |
| Source ID                     | uint32    | Identification number that maps to the source of the server data. Depending on the source type, this may map to RNA, a user, a scanner, or a third-party application.  |
| List Block Type               | uint32    | Initiates a List data block comprising Full Server Information data blocks conveying sub-server data. This value is always 11.   |
| List Block Length             | uint32    | Number of bytes in the list. This number includes the eight bytes of the list block type and length fields, plus all encapsulated Full Sub-Server data blocks.<br><br>This field is followed by zero or more Full Sub-Server data blocks.  |
| Full Sub-Server Block Type    | uint32    | Initiates the first Full Sub-Server data block. This data block can be followed by other Full Sub-Server data blocks up to the limit defined in the list block length field.   |
| Full Sub-Server Block Length  | uint32    | Total number of bytes in each Full Sub-Server data block, including the eight bytes in the Full Sub-Server block type and length fields, plus the number of bytes of data that follows.  |
| Full Sub-Server Data Blocks * | uint32    | Full Sub-Server data blocks containing sub-servers for the server. See <a href="#">Full Sub-Server Data Block, page 4-77</a> for a description of this data block.   |

## Generic Scan Results Data Block for 4.10.0+

The Generic Scan Results data block contains scan results and is used in the [Scan Result Data Block 5.2+, page 4-118](#). The Generic Scan Results data block has a block type of 108 in the series 1 group of blocks.

The following diagram shows the basic structure of a Generic Scan Results data block:

| Byte                    | 0  |   |   |   |   |   |   |   | 1 |   |    |    |    |    |    |    | 2        |    |    |    |    |    |    |    | 3  |    |    |    |    |    |    |    |
|-------------------------|--|---|---|---|---|---|---|---|---|---|----|----|----|----|----|----|----------|----|----|----|----|----|----|----|----|----|----|----|----|----|----|----|
|                         | 0  | 1 | 2 | 3 | 4 | 5 | 6 | 7 | 8 | 9 | 10 | 11 | 12 | 13 | 14 | 15 | 16       | 17 | 18 | 19 | 20 | 21 | 22 | 23 | 24 | 25 | 26 | 27 | 28 | 29 | 30 | 31 |
|                         | Generic Scan Results Data Block Type (108)     |   |   |   |   |   |   |   |   |   |    |    |    |    |    |    |          |    |    |    |    |    |    |    |    |    |    |    |    |    |    |    |
|                         | Generic Scan Results Block Length              |   |   |   |   |   |   |   |   |   |    |    |    |    |    |    |          |    |    |    |    |    |    |    |    |    |    |    |    |    |    |    |
|                         | Port   |   |   |   |   |   |   |   |   |   |    |    |    |    |    |    | Protocol |    |    |    |    |    |    |    |    |    |    |    |    |    |    |    |
| Scan Result Sub-Servers | String Block Type (0)                          |   |   |   |   |   |   |   |   |   |    |    |    |    |    |    |          |    |    |    |    |    |    |    |    |    |    |    |    |    |    |    |
|                         | String Block Length                            |   |   |   |   |   |   |   |   |   |    |    |    |    |    |    |          |    |    |    |    |    |    |    |    |    |    |    |    |    |    |    |
|                         | Scan Result Sub-Server String...               |   |   |   |   |   |   |   |   |   |    |    |    |    |    |    |          |    |    |    |    |    |    |    |    |    |    |    |    |    |    |    |
| Scan Result Value       | String Block Type (0)                          |   |   |   |   |   |   |   |   |   |    |    |    |    |    |    |          |    |    |    |    |    |    |    |    |    |    |    |    |    |    |    |
|                         | String Block Length                            |   |   |   |   |   |   |   |   |   |    |    |    |    |    |    |          |    |    |    |    |    |    |    |    |    |    |    |    |    |    |    |
|                         | Scan Result Value...                           |   |   |   |   |   |   |   |   |   |    |    |    |    |    |    |          |    |    |    |    |    |    |    |    |    |    |    |    |    |    |    |
| Scan Result Sub-Server  | String Block Type (0)                          |   |   |   |   |   |   |   |   |   |    |    |    |    |    |    |          |    |    |    |    |    |    |    |    |    |    |    |    |    |    |    |
|                         | String Block Length                            |   |   |   |   |   |   |   |   |   |    |    |    |    |    |    |          |    |    |    |    |    |    |    |    |    |    |    |    |    |    |    |
|                         | Scan Result Sub-Server (unformatted) String... |   |   |   |   |   |   |   |   |   |    |    |    |    |    |    |          |    |    |    |    |    |    |    |    |    |    |    |    |    |    |    |
| Scan Result Value       | String Block Type (0)                          |   |   |   |   |   |   |   |   |   |    |    |    |    |    |    |          |    |    |    |    |    |    |    |    |    |    |    |    |    |    |    |
|                         | String Block Length                            |   |   |   |   |   |   |   |   |   |    |    |    |    |    |    |          |    |    |    |    |    |    |    |    |    |    |    |    |    |    |    |
|                         | Scan Result Value...                           |   |   |   |   |   |   |   |   |   |    |    |    |    |    |    |          |    |    |    |    |    |    |    |    |    |    |    |    |    |    |    |

The following table describes the fields of the Generic Scan Results data block.

**Table 4-74**      *Generic Scan Result Data Block Fields*

| Field                                | Number of Bytes | Description   |
|--------------------------------------|-----------------|---|
| Generic Scan Results Data Block Type | uint32          | Initiates a Generic Scan Results data block. This value is always 108.  |
| Generic Scan Results Block Length    | uint32          | Total number of bytes in the Generic Scan Results data block, including eight bytes for the generic scan results block type and length fields, plus the number of bytes of scan results data that follows.  |
| Port                                 | uint16          | Port used by the server affected by the vulnerabilities in the results.   |
| Protocol                             | uint16          | IANA protocol number or Ethertype. This is handled differently for Transport and Network layer protocols.<br><br>Transport layer protocols are identified by the IANA protocol number. For example: <ul style="list-style-type: none"> <li>• 6 - TCP</li> <li>• 17 - UDP</li> </ul> Network layer protocols are identified by the decimal form of the IEEE Registration Authority Ethertype. For example: <ul style="list-style-type: none"> <li>• 2048 - IP</li> </ul> |
| String Block Type                    | uint32          | Initiates a String data block that contains the sub-server. This value is always 0.   |
| String Block Length                  | uint32          | Number of bytes in the sub-server String data block, including eight bytes for the block type and length fields, plus the number of bytes in the sub-server.  |
| Scan Result Sub-Server               | string          | Sub-server.   |
| String Block Type                    | uint32          | Initiates a String data block that contains the value. This value is always 0.  |
| String Block Length                  | uint32          | Number of bytes in the value String data block, including eight bytes for the block type and length fields, plus the number of bytes in the value.  |
| Scan result value                    | string          | Scan result value.  |
| String Block Type                    | uint32          | Initiates a String data block that contains the sub-server. This value is always 0.   |
| String Block Length                  | uint32          | Number of bytes in the sub-server String data block, including eight bytes for the block type and length fields, plus the number of bytes in the sub-server.  |
| Scan Result Sub-Server               | string          | Sub-server (unformatted).   |
| String Block Type                    | uint32          | Initiates a String data block that contains the value. This value is always 0.  |



Table 4-74 Generic Scan Result Data Block Fields (continued)

| Field               | Number of Bytes | Description  |
|---------------------|-----------------|--|
| String Block Length | uint32          | Number of bytes in the value String data block, including eight bytes for the block type and length fields, plus the number of bytes in the value. |
| Scan Result Value   | string          | Scan result value (unformatted).   |

## Scan Vulnerability Data Block for 4.10.0+

The Scan Vulnerability data block describes a vulnerability and is used within Scan Result data blocks, which in turn are used in Add Scan Result events (event type 1002, subtype 11). For more information, see [Scan Result Data Block 5.2+, page 4-118](#) and [Add Scan Result Messages, page 4-52](#). The Scan Vulnerability data block has a block type of 109 in the series 1 group of blocks.

The following diagram shows the format of a Scan Vulnerability data block:

| Byte        | 0                                   |   |   |   |   |   |   |   | 1 |   |    |    |    |    |    |    | 2        |    |    |    |    |    |    |    | 3  |    |    |    |    |    |    |    |
|-------------|-------------------------------------|---|---|---|---|---|---|---|---|---|----|----|----|----|----|----|----------|----|----|----|----|----|----|----|----|----|----|----|----|----|----|----|
|             | 0                                   | 1 | 2 | 3 | 4 | 5 | 6 | 7 | 8 | 9 | 10 | 11 | 12 | 13 | 14 | 15 | 16       | 17 | 18 | 19 | 20 | 21 | 22 | 23 | 24 | 25 | 26 | 27 | 28 | 29 | 30 | 31 |
|             | Scan Vulnerability Block Type (109) |   |   |   |   |   |   |   |   |   |    |    |    |    |    |    |          |    |    |    |    |    |    |    |    |    |    |    |    |    |    |    |
|             | Scan Vulnerability Block Length     |   |   |   |   |   |   |   |   |   |    |    |    |    |    |    |          |    |    |    |    |    |    |    |    |    |    |    |    |    |    |    |
|             | Port                                |   |   |   |   |   |   |   |   |   |    |    |    |    |    |    | Protocol |    |    |    |    |    |    |    |    |    |    |    |    |    |    |    |
| ID          | String Block Type (0)               |   |   |   |   |   |   |   |   |   |    |    |    |    |    |    |          |    |    |    |    |    |    |    |    |    |    |    |    |    |    |    |
|             | String Block Length                 |   |   |   |   |   |   |   |   |   |    |    |    |    |    |    |          |    |    |    |    |    |    |    |    |    |    |    |    |    |    |    |
|             | ID                                  |   |   |   |   |   |   |   |   |   |    |    |    |    |    |    |          |    |    |    |    |    |    |    |    |    |    |    |    |    |    |    |
| Name        | String Block Type (0)               |   |   |   |   |   |   |   |   |   |    |    |    |    |    |    |          |    |    |    |    |    |    |    |    |    |    |    |    |    |    |    |
|             | String Block Length                 |   |   |   |   |   |   |   |   |   |    |    |    |    |    |    |          |    |    |    |    |    |    |    |    |    |    |    |    |    |    |    |
|             | Vulnerability Name...               |   |   |   |   |   |   |   |   |   |    |    |    |    |    |    |          |    |    |    |    |    |    |    |    |    |    |    |    |    |    |    |
| Description | String Block Type (0)               |   |   |   |   |   |   |   |   |   |    |    |    |    |    |    |          |    |    |    |    |    |    |    |    |    |    |    |    |    |    |    |
|             | String Block Length                 |   |   |   |   |   |   |   |   |   |    |    |    |    |    |    |          |    |    |    |    |    |    |    |    |    |    |    |    |    |    |    |
|             | Description...                      |   |   |   |   |   |   |   |   |   |    |    |    |    |    |    |          |    |    |    |    |    |    |    |    |    |    |    |    |    |    |    |
| Name Clean  | String Block Type (0)               |   |   |   |   |   |   |   |   |   |    |    |    |    |    |    |          |    |    |    |    |    |    |    |    |    |    |    |    |    |    |    |
|             | String Block Length                 |   |   |   |   |   |   |   |   |   |    |    |    |    |    |    |          |    |    |    |    |    |    |    |    |    |    |    |    |    |    |    |
|             | Vulnerability Name Clean...         |   |   |   |   |   |   |   |   |   |    |    |    |    |    |    |          |    |    |    |    |    |    |    |    |    |    |    |    |    |    |    |

| Byte              | 0                                    |   |   |   |   |   |   |   | 1 |   |    |    |    |    |    |    | 2  |    |    |    |    |    |    |    | 3  |    |    |    |    |    |    |    |
|-------------------|--------------------------------------|---|---|---|---|---|---|---|---|---|----|----|----|----|----|----|----|----|----|----|----|----|----|----|----|----|----|----|----|----|----|----|
| Bit               | 0                                    | 1 | 2 | 3 | 4 | 5 | 6 | 7 | 8 | 9 | 10 | 11 | 12 | 13 | 14 | 15 | 16 | 17 | 18 | 19 | 20 | 21 | 22 | 23 | 24 | 25 | 26 | 27 | 28 | 29 | 30 | 31 |
| Description Clean | String Block Type (0)                |   |   |   |   |   |   |   |   |   |    |    |    |    |    |    |    |    |    |    |    |    |    |    |    |    |    |    |    |    |    |    |
|                   | String Block Length                  |   |   |   |   |   |   |   |   |   |    |    |    |    |    |    |    |    |    |    |    |    |    |    |    |    |    |    |    |    |    |    |
|                   | Description Clean...                 |   |   |   |   |   |   |   |   |   |    |    |    |    |    |    |    |    |    |    |    |    |    |    |    |    |    |    |    |    |    |    |
| Bugtraq ID        | List Block Type (11)                 |   |   |   |   |   |   |   |   |   |    |    |    |    |    |    |    |    |    |    |    |    |    |    |    |    |    |    |    |    |    |    |
|                   | List Block Length                    |   |   |   |   |   |   |   |   |   |    |    |    |    |    |    |    |    |    |    |    |    |    |    |    |    |    |    |    |    |    |    |
|                   | Integer Data Blocks (Bugtraq IDs)... |   |   |   |   |   |   |   |   |   |    |    |    |    |    |    |    |    |    |    |    |    |    |    |    |    |    |    |    |    |    |    |
| CVE ID            | List Block Type (11)                 |   |   |   |   |   |   |   |   |   |    |    |    |    |    |    |    |    |    |    |    |    |    |    |    |    |    |    |    |    |    |    |
|                   | List Block Length                    |   |   |   |   |   |   |   |   |   |    |    |    |    |    |    |    |    |    |    |    |    |    |    |    |    |    |    |    |    |    |    |
|                   | CVE ID...                            |   |   |   |   |   |   |   |   |   |    |    |    |    |    |    |    |    |    |    |    |    |    |    |    |    |    |    |    |    |    |    |

The following table describes the fields of the Scan Vulnerability data block.

Table 4-75 Scan Vulnerability Data Block Fields

| Field                           | Data Type | Description   |
|---------------------------------|-----------|---|
| Scan Vulnerability Block Type   | uint32    | Initiates a Scan Vulnerability data block. This value is always 109.  |
| Scan Vulnerability Block Length | uint32    | Number of bytes in the Scan Vulnerability data block, including eight bytes for the scan vulnerability block type and length fields, plus the number of bytes of scan vulnerability data that follows.  |
| Port                            | uint16    | Port used by the sub-server affected by the vulnerability.  |
| Protocol                        | uint16    | IANA protocol number or Ethertype. This is handled differently for Transport and Network layer protocols.<br><br>Transport layer protocols are identified by the IANA protocol number. For example: <ul style="list-style-type: none"> <li>6 - TCP</li> <li>17 - UDP</li> </ul> Network layer protocols are identified by the decimal form of the IEEE Registration Authority Ethertype. For example: <ul style="list-style-type: none"> <li>2048 - IP</li> </ul> |
| String Block Type               | uint32    | Initiates a String data block for the ID.   |
| String Block Length             | uint32    | Number of bytes in the String data block for the ID, including eight bytes for the string block type and length, plus the number of bytes in the ID.  |

Table 4-75 Scan Vulnerability Data Block Fields (continued)

| Field               | Data Type | Description  |
|---------------------|-----------|--|
| ID                  | string    | The ID for the reported vulnerability as specified by the scan utility that detected it. For a vulnerability detected by a Qualys scan, for example, this field indicates the Qualys ID.   |
| String Block Type   | uint32    | Initiates a String data block for the vulnerability name.  |
| String Block Length | uint32    | Number of bytes in the String data block for the vulnerability name, including eight bytes for the string block type and length, plus the number of bytes in the vulnerability name.   |
| Name                | string    | Name of the vulnerability.   |
| String Block Type   | uint32    | Initiates a String data block for the vulnerability description.   |
| String Block Length | uint32    | Number of bytes in the String data block for the vulnerability description, including eight bytes for the string block type and length, plus the number of bytes in the vulnerability description.                                 |
| Description         | string    | Description of the vulnerability.  |
| String Block Type   | uint32    | Initiates a String data block for the vulnerability name.  |
| String Block Length | uint32    | Number of bytes in the String data block for the vulnerability name, including eight bytes for the string block type and length, plus the number of bytes in the vulnerability name.   |
| Name Clean          | string    | Name of the vulnerability (unformatted).   |
| String Block Type   | uint32    | Initiates a String data block for the vulnerability description.   |
| String Block Length | uint32    | Number of bytes in the String data block for the vulnerability description, including eight bytes for the string block type and length, plus the number of bytes in the vulnerability description.                                 |
| Description Clean   | string    | Description of the vulnerability (unformatted).  |
| List Block Type     | uint32    | Initiates a List data block for the list of Bugtraq identification numbers.  |
| List Block Length   | uint32    | Number of bytes in the List data block for the list of Bugtraq identification numbers, including eight bytes for the string block type and length, plus the number of bytes in the Integer data blocks containing the Bugtraq IDs. |
| Bugtraq ID          | string    | Contains zero or more Integer (INT32) data blocks that form a list of Bugtraq identification numbers. For more information on these data blocks, see <a href="#">Integer (INT32) Data Block, page 4-69</a> .                       |
| List Block Type     | uint32    | Initiates a List data block for the list of Common Vulnerability Exposure (CVE) identification numbers.  |
| List Block Length   | uint32    | Number of bytes in the List data block for the CVE identification number, including eight bytes for the string block type and length, plus the number of bytes in the CVE identification number.                                   |
| CVE ID              | string    | Contains zero or more String Information data blocks that form a list of CVE identification numbers. For more information on these data blocks, see <a href="#">String Information Data Block, page 4-73</a> .                     |

## Full Host Client Application Data Block 5.0+

The Full Host Client Application data block for version 5.0+ describes a client application, plus an appended list of associated web applications and vulnerabilities. The Full Host Client Application data block is used within the Full Host Profile data block (type 111). It has a block type of 112 in the series 1 group of blocks.

The following diagram shows the basic structure of a Full Host Client Application data block for 5.0+:

| Byte            | 0   |   |   |   |   |   |   |   | 1 |   |    |    |    |    |    |    | 2  |    |    |    |    |    |    |    | 3  |    |    |    |    |    |    |    |
|-----------------|---|---|---|---|---|---|---|---|---|---|----|----|----|----|----|----|----|----|----|----|----|----|----|----|----|----|----|----|----|----|----|----|
| Bit             | 0   | 1 | 2 | 3 | 4 | 5 | 6 | 7 | 8 | 9 | 10 | 11 | 12 | 13 | 14 | 15 | 16 | 17 | 18 | 19 | 20 | 21 | 22 | 23 | 24 | 25 | 26 | 27 | 28 | 29 | 30 | 31 |
|                 | Full Host Client Application Block Type (112) |   |   |   |   |   |   |   |   |   |    |    |    |    |    |    |    |    |    |    |    |    |    |    |    |    |    |    |    |    |    |    |
|                 | Full Host Client Application Block Length     |   |   |   |   |   |   |   |   |   |    |    |    |    |    |    |    |    |    |    |    |    |    |    |    |    |    |    |    |    |    |    |
|                 | Hits  |   |   |   |   |   |   |   |   |   |    |    |    |    |    |    |    |    |    |    |    |    |    |    |    |    |    |    |    |    |    |    |
|                 | Last Used                                     |   |   |   |   |   |   |   |   |   |    |    |    |    |    |    |    |    |    |    |    |    |    |    |    |    |    |    |    |    |    |    |
|                 | Application ID                                |   |   |   |   |   |   |   |   |   |    |    |    |    |    |    |    |    |    |    |    |    |    |    |    |    |    |    |    |    |    |    |
| Version         | String Block Type (0)                         |   |   |   |   |   |   |   |   |   |    |    |    |    |    |    |    |    |    |    |    |    |    |    |    |    |    |    |    |    |    |    |
|                 | String Block Length                           |   |   |   |   |   |   |   |   |   |    |    |    |    |    |    |    |    |    |    |    |    |    |    |    |    |    |    |    |    |    |    |
|                 | Version...                                    |   |   |   |   |   |   |   |   |   |    |    |    |    |    |    |    |    |    |    |    |    |    |    |    |    |    |    |    |    |    |    |
|                 | Generic List Block Type (31)                  |   |   |   |   |   |   |   |   |   |    |    |    |    |    |    |    |    |    |    |    |    |    |    |    |    |    |    |    |    |    |    |
|                 | Generic List Block Length                     |   |   |   |   |   |   |   |   |   |    |    |    |    |    |    |    |    |    |    |    |    |    |    |    |    |    |    |    |    |    |    |
| Web Application | Web Application Block Type (123)*             |   |   |   |   |   |   |   |   |   |    |    |    |    |    |    |    |    |    |    |    |    |    |    |    |    |    |    |    |    |    |    |
|                 | Web Application Block Length                  |   |   |   |   |   |   |   |   |   |    |    |    |    |    |    |    |    |    |    |    |    |    |    |    |    |    |    |    |    |    |    |
|                 | Web Application Data...                       |   |   |   |   |   |   |   |   |   |    |    |    |    |    |    |    |    |    |    |    |    |    |    |    |    |    |    |    |    |    |    |
|                 | Generic List Block Type (31)                  |   |   |   |   |   |   |   |   |   |    |    |    |    |    |    |    |    |    |    |    |    |    |    |    |    |    |    |    |    |    |    |
|                 | Generic List Block Length                     |   |   |   |   |   |   |   |   |   |    |    |    |    |    |    |    |    |    |    |    |    |    |    |    |    |    |    |    |    |    |    |
| Vulnerability   | Vulnerability Block Type (85)*                |   |   |   |   |   |   |   |   |   |    |    |    |    |    |    |    |    |    |    |    |    |    |    |    |    |    |    |    |    |    |    |
|                 | Vulnerability Block Length                    |   |   |   |   |   |   |   |   |   |    |    |    |    |    |    |    |    |    |    |    |    |    |    |    |    |    |    |    |    |    |    |
|                 | Vulnerability Data...                         |   |   |   |   |   |   |   |   |   |    |    |    |    |    |    |    |    |    |    |    |    |    |    |    |    |    |    |    |    |    |    |

The following table describes the fields of the Full Host Client Application data block.

*Table 4-76 Full Host Client Application Data Block 5.0+ Fields*

| Field                                     | Data Type | Description  |
|---|-----------|--|
| Full Host Client Application Block Type   | uint32    | Initiates a Full Host Client Application data block. This value is always 112.   |
| Full Host Client Application Block Length | uint32    | Number of bytes in the Full Host Client Application data block, including eight bytes for the client application block type and length, plus the number of bytes in the client application data that follows.                                      |
| Hits                                      | uint32    | Number of times the system has detected the client application in use.   |
| Last Used                                 | uint32    | UNIX timestamp that represents the last time the system detected the client in use.  |
| Application ID                            | uint32    | Application ID of the detected client application, if applicable.  |
| String Block Type                         | uint32    | Initiates a String data block for the client application version. This value is always 0.  |
| String Block Length                       | uint32    | Number of bytes in the String data block for the client application name, including eight bytes for the string block type and length, plus the number of bytes in the client application version.  |
| Version                                   | string    | Client application version.  |
| Generic List Block Type                   | uint32    | Initiates a Generic List data block. This value is always 31.  |
| Generic List Block Length                 | uint32    | Number of bytes in the Generic List block and the encapsulated Web Application data blocks. This number includes the eight bytes of the generic list block header fields, plus the number of bytes in all of the encapsulated data blocks.         |
| Web Application Data Blocks               | variable  | Encapsulated Web Application data blocks up to the maximum number of bytes in the generic list block length.   |
| Generic List Block Type                   | uint32    | Initiates a Generic List data block. This value is always 31.  |
| Generic List Block Length                 | uint32    | Number of bytes in the Generic List block and encapsulated Vulnerability data blocks. This number includes the eight bytes of the generic list block header fields, plus the number of bytes in all of the encapsulated Vulnerability data blocks. |
| Vulnerability Data Blocks                 | variable  | Encapsulated Vulnerability data blocks up to the maximum number of bytes in the generic list block length.   |

## Host Client Application Data Block for 5.0+

The Host Client Application data block for 5.0+ describes a client application and is used within New Client Application events (event type 1000, subtype 7), Client Application Timeout events (event type 1001, subtype 20), and Client Application Update events (event type 1001, subtype 32). The Host Client Application data block for 4.10.2+ has a block type of 122 in the series 1 group of blocks.

The following diagram shows the basic structure of a Host Client Application data block for 5.0+:

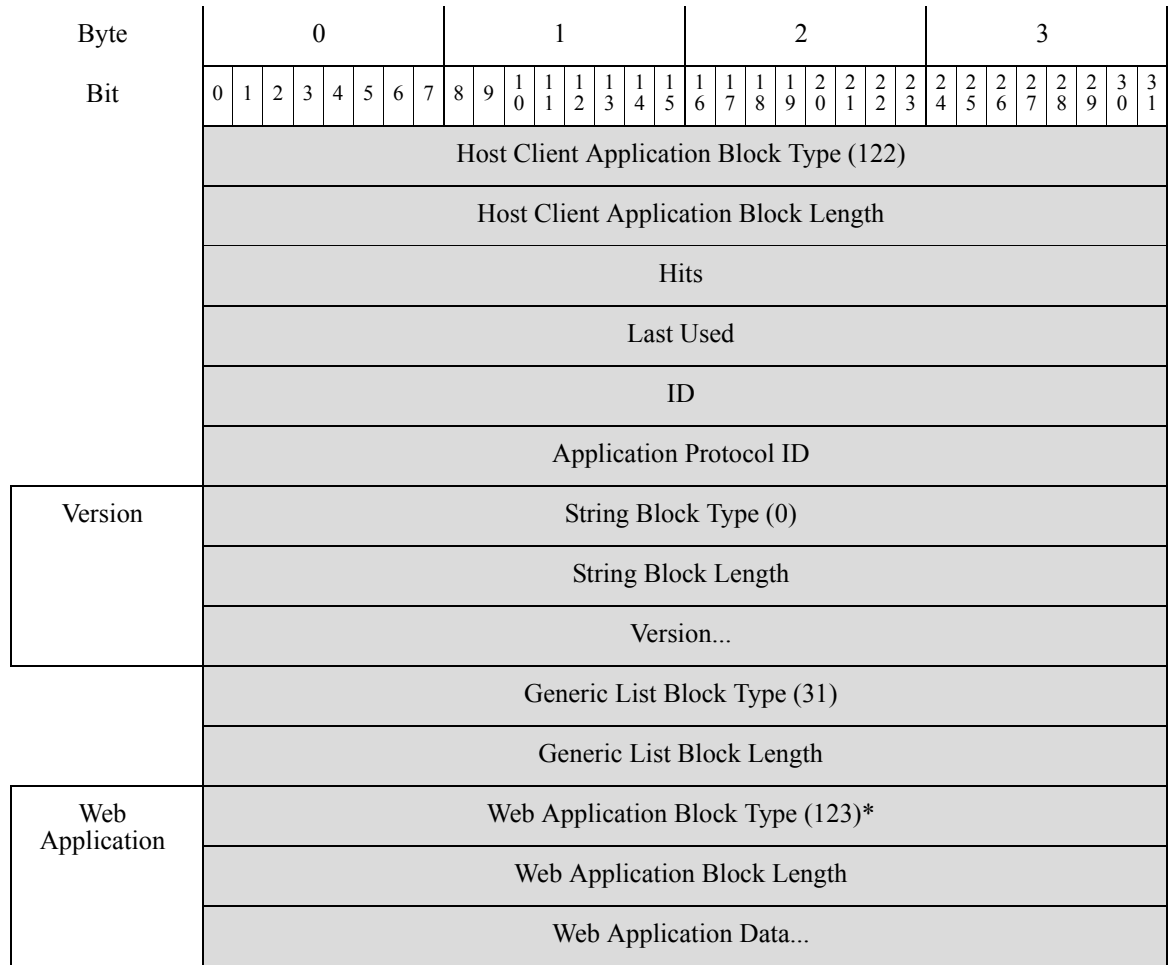

The following table describes the fields of the Host Client Application data block.

**Table 4-77** Host Client Application Data Block Fields

| Field                           | Data Type | Description   |
|---------------------------------|-----------|---|
| Client Application Block Type   | uint32    | Initiates a Host Client Application data block. This value is always 122.   |
| Client Application Block Length | uint32    | Number of bytes in the Client Application data block, including eight bytes for the client application block type and length, plus the number of bytes in the client application data that follows. |
| Hits                            | uint32    | Number of times the system has detected the client application in use.  |
| Last Used                       | uint32    | UNIX timestamp that represents the last time the system detected the client in use.   |
| ID                              | uint32    | Identification number of the detected client application, if applicable.  |

Table 4-77 Host Client Application Data Block Fields (continued)

| Field                       | Data Type | Description  |
|-----------------------------|-----------|--|
| Application Protocol ID     | uint32    | The internal identification number for the application protocol, if applicable.  |
| String Block Type           | uint32    | Initiates a String data block for the client application version. This value is always 0.  |
| String Block Length         | uint32    | Number of bytes in the String data block for the client application version, including eight bytes for the string block type and length, plus the number of bytes in the client application version.                                       |
| Version                     | string    | Client application version.  |
| Generic List Block Type     | uint32    | Initiates a Generic List data block. This value is always 31.  |
| Generic List Block Length   | uint32    | Number of bytes in the Generic List block and encapsulated Web Application data blocks. This number includes the eight bytes of the generic list block header fields, plus the number of bytes in all of the encapsulated data blocks.     |
| Web Application Data Blocks | variable  | Encapsulated Web Application data blocks up to the maximum number of bytes in the list block length. See <a href="#">Web Application Data Block for 5.0+, page 4-110</a> for information on the encapsulated data blocks (block type 123). |

## User Vulnerability Data Block 5.0+

The User Vulnerability data block describes a vulnerability and is used within User Vulnerability Change data blocks. These in turn are used in User Set Valid Vulnerabilities events and User Set Invalid Vulnerabilities events. The User Vulnerability data block for 5.0+ has a block type of 124 in the series 1 group of blocks. It supersedes block type 79. For more information on User Vulnerability Change data blocks, see [User Vulnerability Change Data Block 4.7+, page 4-99](#).

The following diagram shows the format of a User Vulnerability data block:

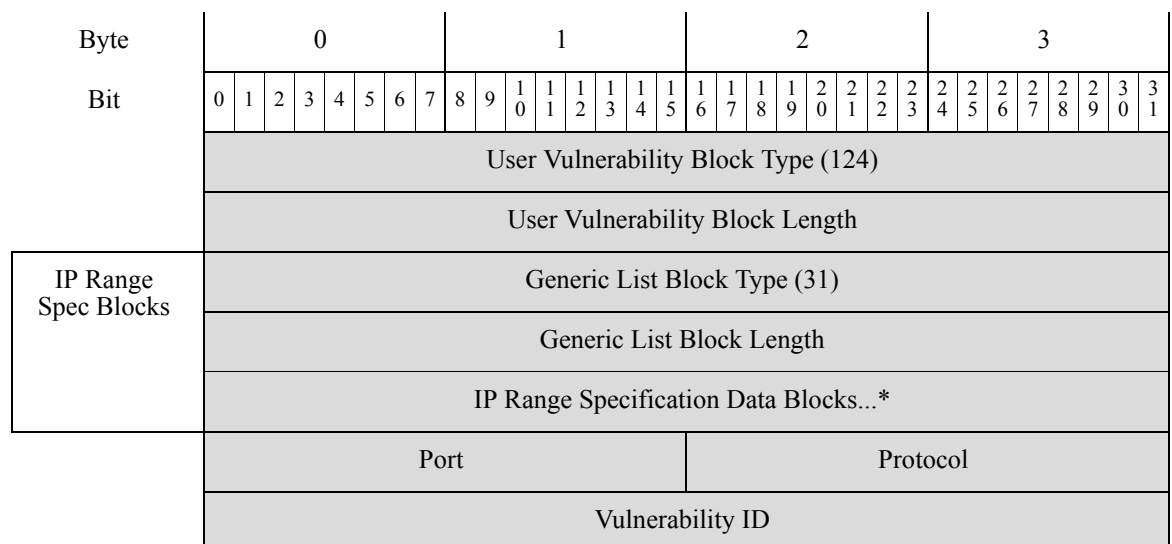

| Byte                | 0  |   |   |   |   |   |   |   | 1 |   |    |    |    |    |    |    | 2  |    |    |    |    |    |    |    | 3  |    |    |    |    |    |    |    |
|---------------------|--|---|---|---|---|---|---|---|---|---|----|----|----|----|----|----|----|----|----|----|----|----|----|----|----|----|----|----|----|----|----|----|
|                     | 0  | 1 | 2 | 3 | 4 | 5 | 6 | 7 | 8 | 9 | 10 | 11 | 12 | 13 | 14 | 15 | 16 | 17 | 18 | 19 | 20 | 21 | 22 | 23 | 24 | 25 | 26 | 27 | 28 | 29 | 30 | 31 |
| 3rd Party Vuln UUID | Third-Party Vulnerability UUID<br>UUID continued<br>UUID continued<br>UUID continued |   |   |   |   |   |   |   |   |   |    |    |    |    |    |    |    |    |    |    |    |    |    |    |    |    |    |    |    |    |    |    |
|                     | String Block Type (0)  |   |   |   |   |   |   |   |   |   |    |    |    |    |    |    |    |    |    |    |    |    |    |    |    |    |    |    |    |    |    |    |
|                     | String Block Length  |   |   |   |   |   |   |   |   |   |    |    |    |    |    |    |    |    |    |    |    |    |    |    |    |    |    |    |    |    |    |    |
|                     | Vulnerability String...  |   |   |   |   |   |   |   |   |   |    |    |    |    |    |    |    |    |    |    |    |    |    |    |    |    |    |    |    |    |    |    |
|                     | Client Application ID  |   |   |   |   |   |   |   |   |   |    |    |    |    |    |    |    |    |    |    |    |    |    |    |    |    |    |    |    |    |    |    |
|                     | Application Protocol ID  |   |   |   |   |   |   |   |   |   |    |    |    |    |    |    |    |    |    |    |    |    |    |    |    |    |    |    |    |    |    |    |
|                     | String Block Type (0)  |   |   |   |   |   |   |   |   |   |    |    |    |    |    |    |    |    |    |    |    |    |    |    |    |    |    |    |    |    |    |    |
|                     | String Block Length  |   |   |   |   |   |   |   |   |   |    |    |    |    |    |    |    |    |    |    |    |    |    |    |    |    |    |    |    |    |    |    |
|                     | Version String...  |   |   |   |   |   |   |   |   |   |    |    |    |    |    |    |    |    |    |    |    |    |    |    |    |    |    |    |    |    |    |    |

The following table describes the fields of the User Vulnerability data block.

Table 4-78 User Vulnerability Data Block Fields

| Field                                | Data Type | Description  |
|--------------------------------------|-----------|--|
| User Vulnerability Block Type        | uint32    | Initiates a User Vulnerability data block. This value is always 124.   |
| User Vulnerability Block Length      | uint32    | Number of bytes in the User Vulnerability data block, including eight bytes for the user vulnerability block type and length fields, plus the number of bytes of user vulnerability data that follows. |
| Generic List Block Type              | uint32    | Initiates a Generic List data block comprising IP Range Specification data blocks conveying IP address range data. This value is always 31.  |
| Generic List Block Length            | uint32    | Number of bytes in the Generic List data block, including the list header and all encapsulated IP Range Specification data blocks.   |
| IP Range Specification Data Blocks * | variable  | IP address ranges from user input. See <a href="#">IP Address Range Data Block for 5.2+, page 4-88</a> for a description of this data block.   |
| Port                                 | uint16    | Port used by the server affected by the vulnerability. For client application vulnerabilities, the value is 0.   |



Table 4-78 User Vulnerability Data Block Fields (continued)

| Field                          | Data Type  | Description   |
|--------------------------------|------------|---|
| Protocol                       | uint16     | IANA protocol number or Ethertype for the protocol used by the server affected by the vulnerability. This is handled differently for Transport and Network layer protocols.<br><br>Transport layer protocols are identified by the IANA protocol number. For example: <ul style="list-style-type: none"> <li>• 6 - TCP</li> <li>• 17 - UDP</li> </ul> Network layer protocols are identified by the decimal form of the IEEE Registration Authority Ethertype. For example: <ul style="list-style-type: none"> <li>• 2048 - IP</li> </ul> For client application vulnerabilities, the value is 0. |
| Vulnerability ID               | uint32     | The Cisco vulnerability ID.   |
| Third-Party Vulnerability UUID | uint8 [16] | A unique ID number for the third-party vulnerability, if one exists. Otherwise, the value is 0.   |
| String Block Type              | uint32     | Initiates a String data block for the vulnerability name. The value is always 0.  |
| String Block Length            | uint32     | The number of bytes in the String data block for the vulnerability name, including eight bytes for the string block type and length, plus the number of bytes in the vulnerability name.  |
| Vulnerability Name             | string     | The vulnerability name.   |
| Client Application ID          | uint32     | The application ID of the client application. For server vulnerabilities, the value is 0.   |
| Application Protocol ID        | uint32     | The application ID of the application protocol used by client application. For server vulnerabilities, the value is 0.  |
| String Block Type              | uint32     | Initiates a String data block for the version string. The value is always 0.  |
| String Block Length            | uint32     | The number of bytes in the String data block for the version, including eight bytes for the string block type and length, plus the number of bytes in the client application version string.  |
| Version                        | string     | The client application version. For server vulnerabilities, the value is 0.   |

## Operating System Fingerprint Data Block 5.1+

The Operating System Fingerprint data block has a block type of 130 in the series 1 group of blocks. The block includes a fingerprint Universally Unique Identifier (UUID), as well as the fingerprint type, the fingerprint source type, and the fingerprint source ID.

The following diagram shows the format of an Operating System Fingerprint data block in 5.1+.

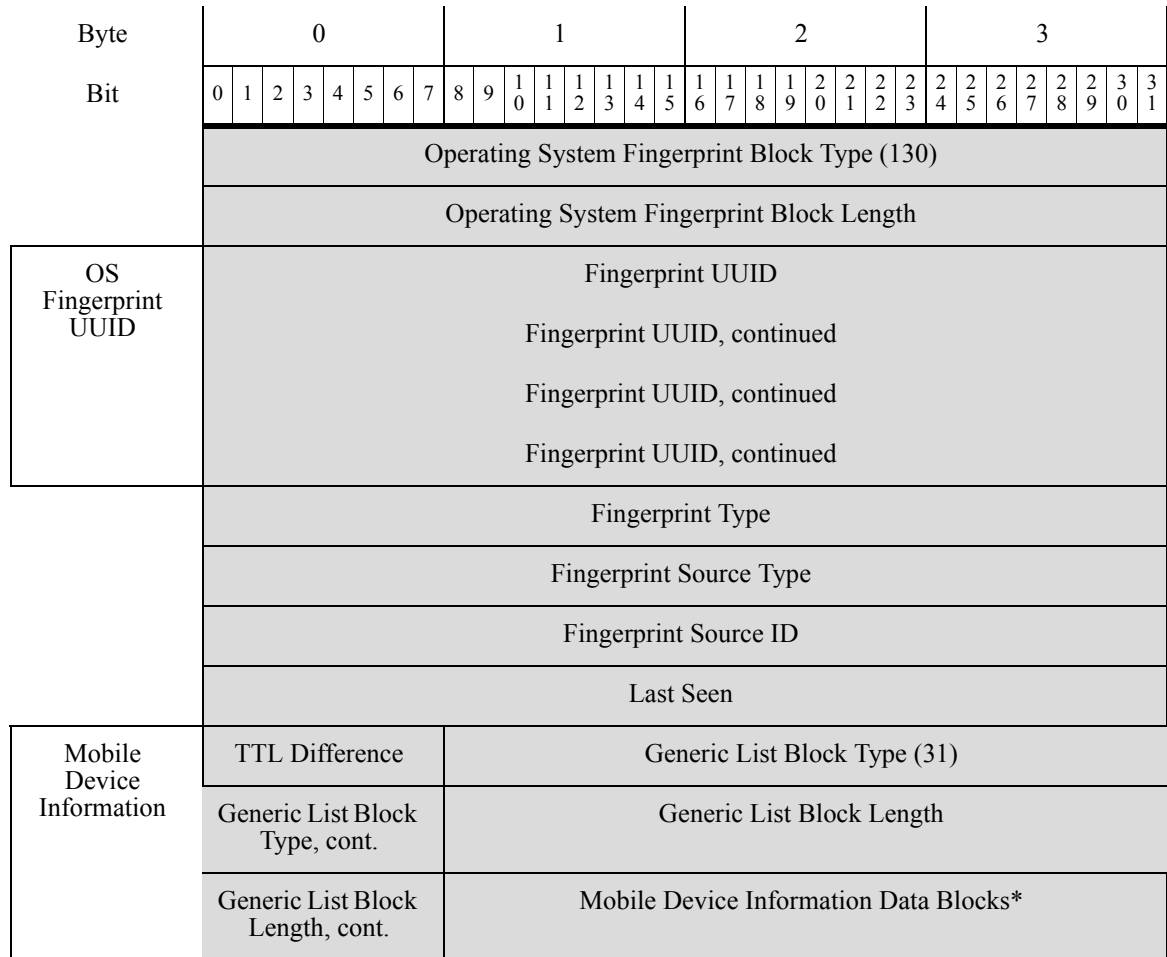

The following table describes the fields of the operating system fingerprint data block.

Table 4-79 Operating System Fingerprint Data Block Fields

| Field  | Data Type | Description  |
|--|-----------|--|
| Operating System Fingerprint Data Block Type | uint32    | Initiates the operating system data block. This value is always 130.   |
| Operating System Data Block Length           | uint32    | Number of bytes in the Operating System Fingerprint data block, including eight bytes for the Operating System Fingerprint Data Block block type and length, plus the number of bytes in the Operating System Fingerprint data that follows. |
| Fingerprint UUID                             | uint8[16] | Fingerprint identification number, in octets, that acts as a unique identifier for the operating system. The fingerprint UUID maps to the operating system name, vendor, and version in the vulnerability database (VDB).                    |
| Fingerprint Type                             | uint32    | Indicates the type of fingerprint.   |

Table 4-79 Operating System Fingerprint Data Block Fields (continued)

| Field                                 | Data Type | Description   |
|---------------------------------------|-----------|---|
| Fingerprint Source Type               | uint32    | Indicates the type (i.e., user or scanner) of the source that supplied the operating system fingerprint.  |
| Fingerprint Source ID                 | uint32    | Identification number that maps to the login name of the user that supplied the operating system fingerprint.   |
| Last Seen                             | uint32    | Indicates when the fingerprint was last seen in traffic.  |
| TTL Difference                        | uint8     | Indicates the difference between the TTL value in the fingerprint and the TTL value seen in the packet used to fingerprint the host.  |
| Generic List Block Type               | uint32    | Initiates a Generic List data block. This value is always 31.   |
| Generic List Block Length             | uint32    | Number of bytes in the Generic List block and encapsulated data blocks. This number includes the eight bytes of the generic list block header fields, plus the number of bytes in all of the encapsulated data blocks.              |
| Mobile Device Information Data Blocks | variable  | Encapsulated Mobile Device Information data blocks up to the maximum number of bytes in the list block length. See <a href="#">Mobile Device Information Data Block for 5.1+</a> , page 4-143 for a description of this data block. |

## Mobile Device Information Data Block for 5.1+

The following diagram shows the format of a Mobile Device Information data block. The data block contains the last time the host was detected, mobile device information, and whether the mobile device is jailbroken. The Mobile Device Information data block has a block type of 131 in the series 1 group of blocks.

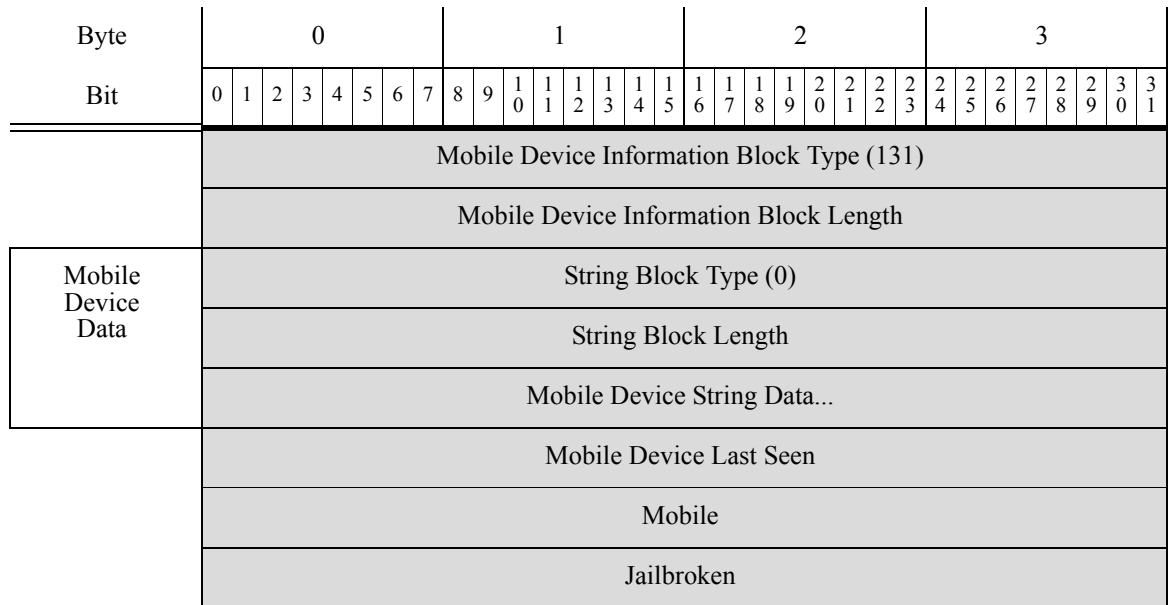

The describes the fields of the Mobile Device Information data block returned by 5.1+.

**Table 4-80** *Mobile Device Information Data Block 5.1+ Fields*

| Field                                      | Data Type | Description   |
|--|-----------|---|
| Mobile Device Information Block Type (131) | uint32    | Initiates the operating system data block. This value is always 131.  |
| Mobile Device Information Block Length     | uint32    | Number of bytes in the Mobile Device Information data block, including eight bytes for the Mobile Device Information Data Block block type and length, plus the number of bytes in the Mobile Device Information data that follows. |
| String Block Type                          | uint32    | Initiates a string data block for the mobile device string. This value is set to 0 to indicate string data.   |
| String Block Length                        | uint32    | Indicates the number of bytes in the mobile device string data block, including eight bytes for the string block type and length fields, plus the number of bytes in the mobile device string data that follows.                    |
| Mobile Device String Data                  | Variable  | Contains the mobile device hardware information of the host detected.   |
| Mobile Device Last Seen                    | uint32    | Contains the time stamp the mobile device was last seen.  |
| Mobile                                     | uint32    | True-false flag indicating whether the host is a mobile device.   |
| Jailbroken                                 | uint32    | True-false flag indicating whether the host is a mobile device that is jailbroken.  |

## Host Profile Data Block for 5.2+

The following diagram shows the format of a Host Profile data block. The data block also does not include a host criticality value, but does include a VLAN presence indicator. In addition, a data block can convey a NetBIOS name for the host. The Host Profile data block has a block type of 139 in the series 1 group of blocks. The data block now supports IPv6 addresses, and client application data blocks have been added.



### Note

An asterisk(\*) next to a block type field in the following diagram indicates the message may contain zero or more instances of the series 1 data block.

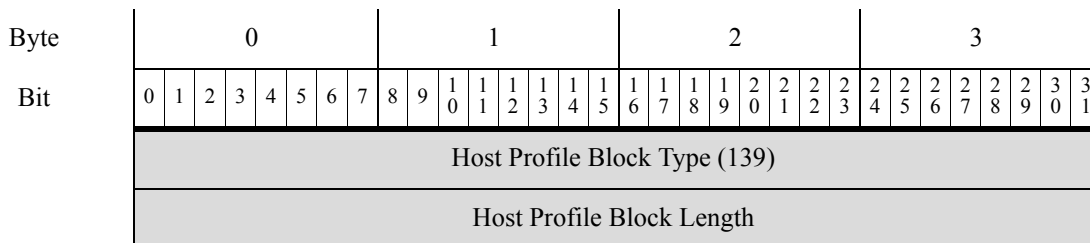

|                            |  |   |   |   |   |   |   |   |                   |   |    |    |    |    |    |    |                                 |    |    |    |    |    |    |    |    |    |    |    |    |    |    |    |
|----------------------------|--|---|---|---|---|---|---|---|-------------------|---|----|----|----|----|----|----|---------------------------------|----|----|----|----|----|----|----|----|----|----|----|----|----|----|----|
| Byte                       | 0                                      |   |   |   |   |   |   |   | 1                 |   |    |    |    |    |    |    | 2                               |    |    |    |    |    |    |    | 3  |    |    |    |    |    |    |    |
| Bit                        | 0                                      | 1 | 2 | 3 | 4 | 5 | 6 | 7 | 8                 | 9 | 10 | 11 | 12 | 13 | 14 | 15 | 16                              | 17 | 18 | 19 | 20 | 21 | 22 | 23 | 24 | 25 | 26 | 27 | 28 | 29 | 30 | 31 |
|                            | IP Address                             |   |   |   |   |   |   |   |                   |   |    |    |    |    |    |    |                                 |    |    |    |    |    |    |    |    |    |    |    |    |    |    |    |
|                            | IP Address, continued                  |   |   |   |   |   |   |   |                   |   |    |    |    |    |    |    |                                 |    |    |    |    |    |    |    |    |    |    |    |    |    |    |    |
|                            | IP Address, continued                  |   |   |   |   |   |   |   |                   |   |    |    |    |    |    |    |                                 |    |    |    |    |    |    |    |    |    |    |    |    |    |    |    |
|                            | IP Address, continued                  |   |   |   |   |   |   |   |                   |   |    |    |    |    |    |    |                                 |    |    |    |    |    |    |    |    |    |    |    |    |    |    |    |
| Server Fingerprints        | Hops                                   |   |   |   |   |   |   |   | Primary/Secondary |   |    |    |    |    |    |    | Generic List Block Type (31)    |    |    |    |    |    |    |    |    |    |    |    |    |    |    |    |
|                            | Generic List Block Type, continued     |   |   |   |   |   |   |   |                   |   |    |    |    |    |    |    | Generic List Block Length       |    |    |    |    |    |    |    |    |    |    |    |    |    |    |    |
|                            | Generic List Block Length, continued   |   |   |   |   |   |   |   |                   |   |    |    |    |    |    |    | Server Fingerprint Data Blocks* |    |    |    |    |    |    |    |    |    |    |    |    |    |    |    |
| Client Fingerprints        | Generic List Block Type (31)           |   |   |   |   |   |   |   |                   |   |    |    |    |    |    |    |                                 |    |    |    |    |    |    |    |    |    |    |    |    |    |    |    |
|                            | Generic List Block Length              |   |   |   |   |   |   |   |                   |   |    |    |    |    |    |    |                                 |    |    |    |    |    |    |    |    |    |    |    |    |    |    |    |
|                            | Client Fingerprint Data Blocks*        |   |   |   |   |   |   |   |                   |   |    |    |    |    |    |    |                                 |    |    |    |    |    |    |    |    |    |    |    |    |    |    |    |
| SMB Fingerprints           | Generic List Block Type (31)           |   |   |   |   |   |   |   |                   |   |    |    |    |    |    |    |                                 |    |    |    |    |    |    |    |    |    |    |    |    |    |    |    |
|                            | Generic List Block Length              |   |   |   |   |   |   |   |                   |   |    |    |    |    |    |    |                                 |    |    |    |    |    |    |    |    |    |    |    |    |    |    |    |
|                            | SMB Fingerprint Data Blocks*           |   |   |   |   |   |   |   |                   |   |    |    |    |    |    |    |                                 |    |    |    |    |    |    |    |    |    |    |    |    |    |    |    |
| DHCP Fingerprints          | Generic List Block Type (31)           |   |   |   |   |   |   |   |                   |   |    |    |    |    |    |    |                                 |    |    |    |    |    |    |    |    |    |    |    |    |    |    |    |
|                            | Generic List Block Length              |   |   |   |   |   |   |   |                   |   |    |    |    |    |    |    |                                 |    |    |    |    |    |    |    |    |    |    |    |    |    |    |    |
|                            | DHCP Fingerprint Data Blocks*          |   |   |   |   |   |   |   |                   |   |    |    |    |    |    |    |                                 |    |    |    |    |    |    |    |    |    |    |    |    |    |    |    |
| Mobile Device Fingerprints | Generic List Block Type (31)           |   |   |   |   |   |   |   |                   |   |    |    |    |    |    |    |                                 |    |    |    |    |    |    |    |    |    |    |    |    |    |    |    |
|                            | Generic List Block Length              |   |   |   |   |   |   |   |                   |   |    |    |    |    |    |    |                                 |    |    |    |    |    |    |    |    |    |    |    |    |    |    |    |
|                            | Mobile Device Fingerprint Data Blocks* |   |   |   |   |   |   |   |                   |   |    |    |    |    |    |    |                                 |    |    |    |    |    |    |    |    |    |    |    |    |    |    |    |
| IPv6 Sever Fingerprints    | Generic List Block Type (31)           |   |   |   |   |   |   |   |                   |   |    |    |    |    |    |    |                                 |    |    |    |    |    |    |    |    |    |    |    |    |    |    |    |
|                            | Generic List Block Length              |   |   |   |   |   |   |   |                   |   |    |    |    |    |    |    |                                 |    |    |    |    |    |    |    |    |    |    |    |    |    |    |    |
|                            | Ipv6 Server Fingerprint Data Blocks*   |   |   |   |   |   |   |   |                   |   |    |    |    |    |    |    |                                 |    |    |    |    |    |    |    |    |    |    |    |    |    |    |    |
| IPv6 Client Fingerprints   | Generic List Block Type (31)           |   |   |   |   |   |   |   |                   |   |    |    |    |    |    |    |                                 |    |    |    |    |    |    |    |    |    |    |    |    |    |    |    |
|                            | Generic List Block Length              |   |   |   |   |   |   |   |                   |   |    |    |    |    |    |    |                                 |    |    |    |    |    |    |    |    |    |    |    |    |    |    |    |
|                            | IPv6 Client Fingerprint Data Blocks*   |   |   |   |   |   |   |   |                   |   |    |    |    |    |    |    |                                 |    |    |    |    |    |    |    |    |    |    |    |    |    |    |    |

Host Discovery and Connection Data Blocks

| Byte                      | 0                                   |   |   |   |   |   |   |            | 1 |   |    |    |    |    |    |               | 2  |    |    |    |    |    |    |         | 3                           |    |    |    |    |    |    |    |
|---------------------------|-------------------------------------|---|---|---|---|---|---|------------|---|---|----|----|----|----|----|---------------|----|----|----|----|----|----|----|---------|-----------------------------|----|----|----|----|----|----|----|
|                           | 0                                   | 1 | 2 | 3 | 4 | 5 | 6 | 7          | 8 | 9 | 10 | 11 | 12 | 13 | 14 | 15            | 16 | 17 | 18 | 19 | 20 | 21 | 22 | 23      | 24                          | 25 | 26 | 27 | 28 | 29 | 30 | 31 |
| IPv6 DHCP Fingerprints    | Generic List Block Type (31)        |   |   |   |   |   |   |            |   |   |    |    |    |    |    |               |    |    |    |    |    |    |    |         |                             |    |    |    |    |    |    |    |
|                           | Generic List Block Length           |   |   |   |   |   |   |            |   |   |    |    |    |    |    |               |    |    |    |    |    |    |    |         |                             |    |    |    |    |    |    |    |
|                           | IPv6 DHCP Fingerprint Data Blocks*  |   |   |   |   |   |   |            |   |   |    |    |    |    |    |               |    |    |    |    |    |    |    |         |                             |    |    |    |    |    |    |    |
| User Agent Fingerprints   | Generic List Block Type (31)        |   |   |   |   |   |   |            |   |   |    |    |    |    |    |               |    |    |    |    |    |    |    |         |                             |    |    |    |    |    |    |    |
|                           | Generic List Block Length           |   |   |   |   |   |   |            |   |   |    |    |    |    |    |               |    |    |    |    |    |    |    |         |                             |    |    |    |    |    |    |    |
|                           | User Agent Fingerprint Data Blocks* |   |   |   |   |   |   |            |   |   |    |    |    |    |    |               |    |    |    |    |    |    |    |         |                             |    |    |    |    |    |    |    |
| TCP Server Block*         | List Block Type (11)                |   |   |   |   |   |   |            |   |   |    |    |    |    |    |               |    |    |    |    |    |    |    |         | List of TCP Servers         |    |    |    |    |    |    |    |
|                           | List Block Length                   |   |   |   |   |   |   |            |   |   |    |    |    |    |    |               |    |    |    |    |    |    |    |         |                             |    |    |    |    |    |    |    |
|                           | TCP Server Data Blocks              |   |   |   |   |   |   |            |   |   |    |    |    |    |    |               |    |    |    |    |    |    |    |         |                             |    |    |    |    |    |    |    |
| UDP Server Block*         | List Block Type (11)                |   |   |   |   |   |   |            |   |   |    |    |    |    |    |               |    |    |    |    |    |    |    |         | List of UDP Servers         |    |    |    |    |    |    |    |
|                           | List Block Length                   |   |   |   |   |   |   |            |   |   |    |    |    |    |    |               |    |    |    |    |    |    |    |         |                             |    |    |    |    |    |    |    |
|                           | UDP Server Data Blocks              |   |   |   |   |   |   |            |   |   |    |    |    |    |    |               |    |    |    |    |    |    |    |         |                             |    |    |    |    |    |    |    |
| Network Protocol Block*   | List Block Type (11)                |   |   |   |   |   |   |            |   |   |    |    |    |    |    |               |    |    |    |    |    |    |    |         | List of Network Protocols   |    |    |    |    |    |    |    |
|                           | List Block Length                   |   |   |   |   |   |   |            |   |   |    |    |    |    |    |               |    |    |    |    |    |    |    |         |                             |    |    |    |    |    |    |    |
|                           | Network Protocol Data Blocks        |   |   |   |   |   |   |            |   |   |    |    |    |    |    |               |    |    |    |    |    |    |    |         |                             |    |    |    |    |    |    |    |
| Transport Protocol Block* | List Block Type (11)                |   |   |   |   |   |   |            |   |   |    |    |    |    |    |               |    |    |    |    |    |    |    |         | List of Transport Protocols |    |    |    |    |    |    |    |
|                           | List Block Length                   |   |   |   |   |   |   |            |   |   |    |    |    |    |    |               |    |    |    |    |    |    |    |         |                             |    |    |    |    |    |    |    |
|                           | Transport Protocol Data Blocks      |   |   |   |   |   |   |            |   |   |    |    |    |    |    |               |    |    |    |    |    |    |    |         |                             |    |    |    |    |    |    |    |
| MAC Address Block*        | List Block Type (11)                |   |   |   |   |   |   |            |   |   |    |    |    |    |    |               |    |    |    |    |    |    |    |         | List of MAC Addresses       |    |    |    |    |    |    |    |
|                           | List Block Length                   |   |   |   |   |   |   |            |   |   |    |    |    |    |    |               |    |    |    |    |    |    |    |         |                             |    |    |    |    |    |    |    |
|                           | Host MAC Address Data Blocks        |   |   |   |   |   |   |            |   |   |    |    |    |    |    |               |    |    |    |    |    |    |    |         |                             |    |    |    |    |    |    |    |
| Host Last Seen            |                                     |   |   |   |   |   |   |            |   |   |    |    |    |    |    |               |    |    |    |    |    |    |    |         |                             |    |    |    |    |    |    |    |
| Host Type                 |                                     |   |   |   |   |   |   |            |   |   |    |    |    |    |    |               |    |    |    |    |    |    |    |         |                             |    |    |    |    |    |    |    |
| Mobile                    |                                     |   |   |   |   |   |   | Jailbroken |   |   |    |    |    |    |    | VLAN Presence |    |    |    |    |    |    |    | VLAN ID |                             |    |    |    |    |    |    |    |

| Byte            | 0                                   |   |   |   |   |   |   |   | 1         |   |    |    |    |    |    |    | 2                              |    |    |    |    |    |    |    | 3                            |    |    |    |    |    |    |    |                             |
|-----------------|-------------------------------------|---|---|---|---|---|---|---|-----------|---|----|----|----|----|----|----|--------------------------------|----|----|----|----|----|----|----|------------------------------|----|----|----|----|----|----|----|-----------------------------|
|                 | 0                                   | 1 | 2 | 3 | 4 | 5 | 6 | 7 | 8         | 9 | 10 | 11 | 12 | 13 | 14 | 15 | 16                             | 17 | 18 | 19 | 20 | 21 | 22 | 23 | 24                           | 25 | 26 | 27 | 28 | 29 | 30 | 31 |                             |
| Client App Data | VLAN ID, cont.                      |   |   |   |   |   |   |   | VLAN Type |   |    |    |    |    |    |    | VLAN Priority                  |    |    |    |    |    |    |    | Generic List Block Type (31) |    |    |    |    |    |    |    | List of Client Applications |
|                 | Generic List Block Type (31), cont. |   |   |   |   |   |   |   |           |   |    |    |    |    |    |    | Generic List Block Length      |    |    |    |    |    |    |    |                              |    |    |    |    |    |    |    |                             |
|                 | Generic List Block Length, cont.    |   |   |   |   |   |   |   |           |   |    |    |    |    |    |    | Client Application Data Blocks |    |    |    |    |    |    |    |                              |    |    |    |    |    |    |    |                             |
| NetBIOS Name    | String Block Type (0)               |   |   |   |   |   |   |   |           |   |    |    |    |    |    |    |                                |    |    |    |    |    |    |    |                              |    |    |    |    |    |    |    |                             |
|                 | String Block Length                 |   |   |   |   |   |   |   |           |   |    |    |    |    |    |    |                                |    |    |    |    |    |    |    |                              |    |    |    |    |    |    |    |                             |
|                 | NetBIOS String Data...              |   |   |   |   |   |   |   |           |   |    |    |    |    |    |    |                                |    |    |    |    |    |    |    |                              |    |    |    |    |    |    |    |                             |

The following table describes the fields of the host profile data block returned by 5.2+.

**Table 4-81** Host Profile Data Block 5.2+ Fields

| Field   | Data Type | Description   |
|---|-----------|---|
| Host Profile Block Type   | uint32    | Initiates the Host Profile data block for 5.2+. This value is always 139.   |
| Host Profile Block Length                                       | uint32    | Number of bytes in the Host Profile data block, including eight bytes for the host profile block type and length fields, plus the number of bytes included in the host profile data that follows.   |
| IP Address  | uint8(16) | IP Address of the host. This can be IPv4 or IPv6.   |
| Hops  | uint8     | Number of hops from the host to the device.   |
| Primary/Secondary   | uint8     | Indicates whether the host is in the primary or secondary network of the device that detected it: <ul style="list-style-type: none"> <li>0 — host is in the primary network.</li> <li>1 — host is in the secondary network.</li> </ul>                          |
| Generic List Block Type   | uint32    | Initiates a Generic List data block comprising Operating System Fingerprint data blocks conveying fingerprint data identified using a server fingerprint. This value is always 31.  |
| Generic List Block Length                                       | uint32    | Number of bytes in the Generic List data block, including the list header and all encapsulated Operating System Fingerprint data blocks.  |
| Operating System Fingerprint (Server Fingerprint) Data Blocks * | variable  | Operating System Fingerprint data blocks containing information about the operating system on a host identified using a server fingerprint. See <a href="#">Operating System Fingerprint Data Block 5.1+</a> , page 4-141 for a description of this data block. |

Table 4-81 Host Profile Data Block 5.2+ Fields (continued)

| Field   | Data Type | Description   |
|---|-----------|---|
| Generic List Block Type   | uint32    | Initiates a Generic List data block comprising Operating System Fingerprint data blocks conveying fingerprint data identified using a client fingerprint. This value is always 31.  |
| Generic List Block Length                                       | uint32    | Number of bytes in the Generic List data block, including the list header and all encapsulated Operating System Fingerprint data blocks.  |
| Operating System Fingerprint (Client Fingerprint) Data Blocks * | variable  | Operating System Fingerprint data blocks containing information about the operating system on a host identified using a client fingerprint. See <a href="#">Operating System Fingerprint Data Block 5.1+</a> , <a href="#">page 4-141</a> for a description of this data block. |
| Generic List Block Type   | uint32    | Initiates a Generic List data block comprising Operating System Fingerprint data blocks conveying fingerprint data identified using an SMB fingerprint. This value is always 31.  |
| Generic List Block Length                                       | uint32    | Number of bytes in the Generic List data block, including the list header and all encapsulated Operating System Fingerprint data blocks.  |
| Operating System Fingerprint (SMB Fingerprint) Data Blocks *    | variable  | Operating System Fingerprint data blocks containing information about the operating system on a host identified using an SMB fingerprint. See <a href="#">Operating System Fingerprint Data Block 5.1+</a> , <a href="#">page 4-141</a> for a description of this data block.   |
| Generic List Block Type   | uint32    | Initiates a Generic List data block comprising Operating System Fingerprint data blocks conveying fingerprint data identified using a DHCP fingerprint. This value is always 31.  |
| Generic List Block Length                                       | uint32    | Number of bytes in the Generic List data block, including the list header and all encapsulated Operating System Fingerprint data blocks.  |
| Operating System Fingerprint (DHCP Fingerprint) Data Blocks *   | variable  | Operating System Fingerprint data blocks containing information about the operating system on a host identified using a DHCP fingerprint. See <a href="#">Operating System Fingerprint Data Block 5.1+</a> , <a href="#">page 4-141</a> for a description of this data block.   |
| Generic List Block Type   | uint32    | Initiates a Generic List data block comprising Operating System Fingerprint data blocks conveying fingerprint data identified using a mobile device fingerprint. This value is always 31.   |
| Generic List Block Length                                       | uint32    | Number of bytes in the Generic List data block, including the list header and all encapsulated Operating System Fingerprint data blocks.  |



Table 4-81 Host Profile Data Block 5.2+ Fields (continued)

| Field  | Data Type | Description  |
|--|-----------|--|
| Operating System Fingerprint (Mobile) Data Blocks *                | variable  | Operating System Fingerprint data blocks containing information about the operating system on a host identified using a mobile device fingerprint. See <a href="#">Operating System Fingerprint Data Block 5.1+</a> , page 4-141 for a description of this data block. |
| Generic List Block Type  | uint32    | Initiates a Generic List data block comprising Operating System Fingerprint data blocks conveying fingerprint data identified using an IPv6 server fingerprint. This value is always 31.   |
| Generic List Block Length  | uint32    | Number of bytes in the Generic List data block, including the list header and all encapsulated Operating System Fingerprint data blocks.   |
| Operating System Fingerprint (IPv6 Server) Data Blocks *           | variable  | Operating System Fingerprint data blocks containing information about the operating system on a host identified using an IPv6 server fingerprint. See <a href="#">Operating System Fingerprint Data Block 5.1+</a> , page 4-141 for a description of this data block.  |
| Generic List Block Type  | uint32    | Initiates a Generic List data block comprising Operating System Fingerprint data blocks conveying fingerprint data identified using an IPv6 client fingerprint. This value is always 31.   |
| Generic List Block Length  | uint32    | Number of bytes in the Generic List data block, including the list header and all encapsulated Operating System Fingerprint data blocks.   |
| Operating System Fingerprint (IPv6 Client) Data Blocks *           | variable  | Operating System Fingerprint data blocks containing information about the operating system on a host identified using an IPv6 client fingerprint. See <a href="#">Operating System Fingerprint Data Block 5.1+</a> , page 4-141 for a description of this data block.  |
| Generic List Block Type  | uint32    | Initiates a Generic List data block comprising Operating System Fingerprint data blocks conveying fingerprint data identified using an IPv6 DHCP fingerprint. This value is always 31.   |
| Generic List Block Length  | uint32    | Number of bytes in the Generic List data block, including the list header and all encapsulated Operating System Fingerprint data blocks.   |
| Operating System Fingerprint (IPv6 DHCP Fingerprint) Data Blocks * | variable  | Operating System Fingerprint data blocks containing information about the operating system on a host identified using an IPv6 DHCP fingerprint. See <a href="#">Operating System Fingerprint Data Block 5.1+</a> , page 4-141 for a description of this data block.    |
| Generic List Block Type  | uint32    | Initiates a Generic List data block comprising Operating System Fingerprint data blocks conveying fingerprint data identified using a user agent fingerprint. This value is always 31.   |
| Generic List Block Length  | uint32    | Number of bytes in the Generic List data block, including the list header and all encapsulated Operating System Fingerprint data blocks.   |

Table 4-81 Host Profile Data Block 5.2+ Fields (continued)

| Field   | Data Type | Description   |
|---|-----------|---|
| Operating System Fingerprint (User Agent Fingerprint) Data Blocks * | variable  | Operating System Fingerprint data blocks containing information about the operating system on a host identified using a user agent fingerprint. See <a href="#">Operating System Fingerprint Data Block 5.1+</a> , page 4-141 for a description of this data block. |
| List Block Type   | uint32    | Initiates a List data block comprising Server data blocks conveying TCP server data. This value is always 11.   |
| List Block Length   | uint32    | Number of bytes in the list. This number includes the eight bytes of the list block type and length fields, plus all encapsulated Server data blocks.<br><br>This field is followed by zero or more Server data blocks.   |
| TCP Server Data Blocks  | variable  | Host server data blocks describing a TCP server. See <a href="#">Host Server Data Block 4.10.0+</a> , page 4-120 for a description of this data block.  |
| List Block Type   | uint32    | Initiates a List data block comprising Server data blocks conveying UDP server data. This value is always 11.   |
| List Block Length   | uint32    | Number of bytes in the list. This number includes the eight bytes of the list block type and length fields, plus all encapsulated Server data blocks.<br><br>This field is followed by zero or more Server data blocks.   |
| UDP Server Data Blocks  | uint32    | Host server data blocks describing a UDP server. See <a href="#">Host Server Data Block 4.10.0+</a> , page 4-120 for a description of this data block.  |
| List Block Type   | uint32    | Initiates a List data block comprising Protocol data blocks conveying network protocol data. This value is always 11.   |
| List Block Length   | uint32    | Number of bytes in the list. This number includes the eight bytes of the list block type and length fields, plus all encapsulated Protocol data blocks.<br><br>This field is followed by zero or more Protocol data blocks.   |
| Network Protocol Data Blocks  | uint32    | Protocol data blocks describing a network protocol. See <a href="#">Protocol Data Block</a> , page 4-68 for a description of this data block.   |
| List Block Type   | uint32    | Initiates a List data block comprising Protocol data blocks conveying transport protocol data. This value is always 11.   |
| List Block Length   | uint32    | Number of bytes in the list. This number includes the eight bytes of the list block type and length fields, plus all encapsulated Protocol data blocks.<br><br>This field is followed by zero or more transport protocol data blocks.                               |
| Transport Protocol Data Blocks                                      | uint32    | Protocol data blocks describing a transport protocol. See <a href="#">Protocol Data Block</a> , page 4-68 for a description of this data block.   |
| List Block Type   | uint32    | Initiates a List data block comprising MAC Address data blocks. This value is always 11.  |
| List Block Length   | uint32    | Number of bytes in the list, including the list header and all encapsulated MAC Address data blocks.  |

Table 4-81 Host Profile Data Block 5.2+ Fields (continued)

| Field                               | Data Type | Description  |
|-------------------------------------|-----------|--|
| Host MAC Address Data Blocks        | uint32    | Host MAC Address data blocks describing a host MAC address. See <a href="#">Host MAC Address 4.9+</a> , page 4-108 for a description of this data block.   |
| Host Last Seen                      | uint32    | UNIX timestamp that represents the last time the system detected host activity.  |
| Host Type                           | uint32    | Indicates the host type. The following values may appear: <ul style="list-style-type: none"> <li>• 0 - host</li> <li>• 1 - router</li> <li>• 2 - bridge</li> <li>• 3 - NAT device</li> <li>• 4 - LB (load balancer)</li> </ul> |
| Mobile                              | uint8     | True-false flag indicating whether the host is a mobile device.  |
| Jailbroken                          | uint8     | True-false flag indicating whether the host is a mobile device that is also jailbroken.  |
| VLAN Presence                       | uint8     | Indicates whether a VLAN is present: <ul style="list-style-type: none"> <li>• 0 - Yes</li> <li>• 1 - No</li> </ul>   |
| VLAN ID                             | uint16    | VLAN identification number that indicates which VLAN the host is a member of.  |
| VLAN Type                           | uint8     | Type of packet encapsulated in the VLAN tag.   |
| VLAN Priority                       | uint8     | Priority value included in the VLAN tag.   |
| String Block Type                   | uint32    | Initiates a String data block for the host client application data. This value is always 112.  |
| String Block Length                 | uint32    | Number of bytes in the String data block, including eight bytes for the string block type and length fields, plus the number of bytes in the host client application data.   |
| Host Client Application Data Blocks | variable  | List of Client Application data blocks. See <a href="#">Full Host Client Application Data Block 5.0+</a> , page 4-136 for a description of this data block.  |
| String Block Type                   | uint32    | Initiates a String data block for the host NetBIOS name. This value is always 0.   |
| String Block Length                 | uint32    | Number of bytes in the String data block, including eight bytes for the string block type and length fields, plus the number of bytes in the NetBIOS name string.  |
| NetBIOS Name                        | string    | Host NetBIOS name string.  |

## User Product Data Block 5.1+

The User Product data block conveys host input data imported from a third-party application, including third-party application string mappings. This data block is used in [Scan Result Data Block 5.2+](#), [page 4-118](#) and [User Server and Operating System Messages, page 4-51](#). The User Product data block has a block type of 65 in the series 1 group of blocks for versions up to 4.7-4.10.1, a block type of 118 for 4.10.2-5.0.x, and a block type of 134 in the series 1 group of blocks for 5.1+. Block types 65 and 118 have the same structure.

**Note**

An asterisk(\*) next to a data block name in the following diagram indicates that multiple instances of the data block may occur.

The following diagram shows the format of the User Product data block:

| Byte                  | 0                                   |   |   |   |   |   |   |   | 1 |   |    |    |    |    |    |    | 2        |    |    |    |    |    |    |    | 3  |    |    |    |    |    |    |    |
|-----------------------|-------------------------------------|---|---|---|---|---|---|---|---|---|----|----|----|----|----|----|----------|----|----|----|----|----|----|----|----|----|----|----|----|----|----|----|
| Bit                   | 0                                   | 1 | 2 | 3 | 4 | 5 | 6 | 7 | 8 | 9 | 10 | 11 | 12 | 13 | 14 | 15 | 16       | 17 | 18 | 19 | 20 | 21 | 22 | 23 | 24 | 25 | 26 | 27 | 28 | 29 | 30 | 31 |
|                       | User Product Data Block Type (134)  |   |   |   |   |   |   |   |   |   |    |    |    |    |    |    |          |    |    |    |    |    |    |    |    |    |    |    |    |    |    |    |
|                       | User Product Block Length           |   |   |   |   |   |   |   |   |   |    |    |    |    |    |    |          |    |    |    |    |    |    |    |    |    |    |    |    |    |    |    |
|                       | Source ID                           |   |   |   |   |   |   |   |   |   |    |    |    |    |    |    |          |    |    |    |    |    |    |    |    |    |    |    |    |    |    |    |
|                       | Source Type                         |   |   |   |   |   |   |   |   |   |    |    |    |    |    |    |          |    |    |    |    |    |    |    |    |    |    |    |    |    |    |    |
| IP Address Ranges     | Generic List Block Type (31)        |   |   |   |   |   |   |   |   |   |    |    |    |    |    |    |          |    |    |    |    |    |    |    |    |    |    |    |    |    |    |    |
|                       | Generic List Block Length           |   |   |   |   |   |   |   |   |   |    |    |    |    |    |    |          |    |    |    |    |    |    |    |    |    |    |    |    |    |    |    |
|                       | IP Range Specification Data Blocks* |   |   |   |   |   |   |   |   |   |    |    |    |    |    |    |          |    |    |    |    |    |    |    |    |    |    |    |    |    |    |    |
|                       | Port                                |   |   |   |   |   |   |   |   |   |    |    |    |    |    |    | Protocol |    |    |    |    |    |    |    |    |    |    |    |    |    |    |    |
|                       | Drop User Product                   |   |   |   |   |   |   |   |   |   |    |    |    |    |    |    |          |    |    |    |    |    |    |    |    |    |    |    |    |    |    |    |
| Custom Vendor String  | String Block Type (0)               |   |   |   |   |   |   |   |   |   |    |    |    |    |    |    |          |    |    |    |    |    |    |    |    |    |    |    |    |    |    |    |
|                       | String Block Length                 |   |   |   |   |   |   |   |   |   |    |    |    |    |    |    |          |    |    |    |    |    |    |    |    |    |    |    |    |    |    |    |
|                       | Custom Vendor String...             |   |   |   |   |   |   |   |   |   |    |    |    |    |    |    |          |    |    |    |    |    |    |    |    |    |    |    |    |    |    |    |
| Custom Product String | String Block Type (0)               |   |   |   |   |   |   |   |   |   |    |    |    |    |    |    |          |    |    |    |    |    |    |    |    |    |    |    |    |    |    |    |
|                       | String Block Length                 |   |   |   |   |   |   |   |   |   |    |    |    |    |    |    |          |    |    |    |    |    |    |    |    |    |    |    |    |    |    |    |
|                       | Custom Product String...            |   |   |   |   |   |   |   |   |   |    |    |    |    |    |    |          |    |    |    |    |    |    |    |    |    |    |    |    |    |    |    |

| Byte                  | 0                          |   |   |   |   |   |   |   | 1 |   |    |    |    |    |    |    | 2  |    |    |    |    |    |    |    | 3  |    |    |    |    |    |    |    |
|-----------------------|----------------------------|---|---|---|---|---|---|---|---|---|----|----|----|----|----|----|----|----|----|----|----|----|----|----|----|----|----|----|----|----|----|----|
|                       | 0                          | 1 | 2 | 3 | 4 | 5 | 6 | 7 | 8 | 9 | 10 | 11 | 12 | 13 | 14 | 15 | 16 | 17 | 18 | 19 | 20 | 21 | 22 | 23 | 24 | 25 | 26 | 27 | 28 | 29 | 30 | 31 |
| Custom Version String | String Block Type (0)      |   |   |   |   |   |   |   |   |   |    |    |    |    |    |    |    |    |    |    |    |    |    |    |    |    |    |    |    |    |    |    |
|                       | String Block Length        |   |   |   |   |   |   |   |   |   |    |    |    |    |    |    |    |    |    |    |    |    |    |    |    |    |    |    |    |    |    |    |
|                       | Custom Version String...   |   |   |   |   |   |   |   |   |   |    |    |    |    |    |    |    |    |    |    |    |    |    |    |    |    |    |    |    |    |    |    |
|                       | Software ID                |   |   |   |   |   |   |   |   |   |    |    |    |    |    |    |    |    |    |    |    |    |    |    |    |    |    |    |    |    |    |    |
|                       | Server ID                  |   |   |   |   |   |   |   |   |   |    |    |    |    |    |    |    |    |    |    |    |    |    |    |    |    |    |    |    |    |    |    |
|                       | Vendor ID                  |   |   |   |   |   |   |   |   |   |    |    |    |    |    |    |    |    |    |    |    |    |    |    |    |    |    |    |    |    |    |    |
|                       | Product ID                 |   |   |   |   |   |   |   |   |   |    |    |    |    |    |    |    |    |    |    |    |    |    |    |    |    |    |    |    |    |    |    |
| Major Version String  | String Block Type (0)      |   |   |   |   |   |   |   |   |   |    |    |    |    |    |    |    |    |    |    |    |    |    |    |    |    |    |    |    |    |    |    |
|                       | String Block Length        |   |   |   |   |   |   |   |   |   |    |    |    |    |    |    |    |    |    |    |    |    |    |    |    |    |    |    |    |    |    |    |
|                       | Major Version String...    |   |   |   |   |   |   |   |   |   |    |    |    |    |    |    |    |    |    |    |    |    |    |    |    |    |    |    |    |    |    |    |
| Minor Version String  | String Block Type (0)      |   |   |   |   |   |   |   |   |   |    |    |    |    |    |    |    |    |    |    |    |    |    |    |    |    |    |    |    |    |    |    |
|                       | String Block Length        |   |   |   |   |   |   |   |   |   |    |    |    |    |    |    |    |    |    |    |    |    |    |    |    |    |    |    |    |    |    |    |
|                       | Minor Version String...    |   |   |   |   |   |   |   |   |   |    |    |    |    |    |    |    |    |    |    |    |    |    |    |    |    |    |    |    |    |    |    |
| Revision String       | String Block Type (0)      |   |   |   |   |   |   |   |   |   |    |    |    |    |    |    |    |    |    |    |    |    |    |    |    |    |    |    |    |    |    |    |
|                       | String Block Length        |   |   |   |   |   |   |   |   |   |    |    |    |    |    |    |    |    |    |    |    |    |    |    |    |    |    |    |    |    |    |    |
|                       | Revision String...         |   |   |   |   |   |   |   |   |   |    |    |    |    |    |    |    |    |    |    |    |    |    |    |    |    |    |    |    |    |    |    |
| To Major String       | String Block Type (0)      |   |   |   |   |   |   |   |   |   |    |    |    |    |    |    |    |    |    |    |    |    |    |    |    |    |    |    |    |    |    |    |
|                       | String Block Length        |   |   |   |   |   |   |   |   |   |    |    |    |    |    |    |    |    |    |    |    |    |    |    |    |    |    |    |    |    |    |    |
|                       | To Major Version String... |   |   |   |   |   |   |   |   |   |    |    |    |    |    |    |    |    |    |    |    |    |    |    |    |    |    |    |    |    |    |    |
| To Minor String       | String Block Type (0)      |   |   |   |   |   |   |   |   |   |    |    |    |    |    |    |    |    |    |    |    |    |    |    |    |    |    |    |    |    |    |    |
|                       | String Block Length        |   |   |   |   |   |   |   |   |   |    |    |    |    |    |    |    |    |    |    |    |    |    |    |    |    |    |    |    |    |    |    |
|                       | To Minor Version String... |   |   |   |   |   |   |   |   |   |    |    |    |    |    |    |    |    |    |    |    |    |    |    |    |    |    |    |    |    |    |    |
| To Revision String    | String Block Type (0)      |   |   |   |   |   |   |   |   |   |    |    |    |    |    |    |    |    |    |    |    |    |    |    |    |    |    |    |    |    |    |    |
|                       | String Block Length        |   |   |   |   |   |   |   |   |   |    |    |    |    |    |    |    |    |    |    |    |    |    |    |    |    |    |    |    |    |    |    |
|                       | To Revision String...      |   |   |   |   |   |   |   |   |   |    |    |    |    |    |    |    |    |    |    |    |    |    |    |    |    |    |    |    |    |    |    |

| Byte             | 0                                  |   |   |   |   |   |   |   | 1          |   |    |    |    |    |    |    | 2                            |    |    |    |    |    |    |    | 3  |    |    |    |    |    |    |    |
|------------------|------------------------------------|---|---|---|---|---|---|---|------------|---|----|----|----|----|----|----|------------------------------|----|----|----|----|----|----|----|----|----|----|----|----|----|----|----|
|                  | 0                                  | 1 | 2 | 3 | 4 | 5 | 6 | 7 | 8          | 9 | 10 | 11 | 12 | 13 | 14 | 15 | 16                           | 17 | 18 | 19 | 20 | 21 | 22 | 23 | 24 | 25 | 26 | 27 | 28 | 29 | 30 | 31 |
| Build String     | String Block Type (0)              |   |   |   |   |   |   |   |            |   |    |    |    |    |    |    |                              |    |    |    |    |    |    |    |    |    |    |    |    |    |    |    |
|                  | String Block Length                |   |   |   |   |   |   |   |            |   |    |    |    |    |    |    |                              |    |    |    |    |    |    |    |    |    |    |    |    |    |    |    |
|                  | Build String...                    |   |   |   |   |   |   |   |            |   |    |    |    |    |    |    |                              |    |    |    |    |    |    |    |    |    |    |    |    |    |    |    |
| Patch String     | String Block Type (0)              |   |   |   |   |   |   |   |            |   |    |    |    |    |    |    |                              |    |    |    |    |    |    |    |    |    |    |    |    |    |    |    |
|                  | String Block Length                |   |   |   |   |   |   |   |            |   |    |    |    |    |    |    |                              |    |    |    |    |    |    |    |    |    |    |    |    |    |    |    |
|                  | Patch String...                    |   |   |   |   |   |   |   |            |   |    |    |    |    |    |    |                              |    |    |    |    |    |    |    |    |    |    |    |    |    |    |    |
| Extension String | String Block Type (0)              |   |   |   |   |   |   |   |            |   |    |    |    |    |    |    |                              |    |    |    |    |    |    |    |    |    |    |    |    |    |    |    |
|                  | String Block Length                |   |   |   |   |   |   |   |            |   |    |    |    |    |    |    |                              |    |    |    |    |    |    |    |    |    |    |    |    |    |    |    |
|                  | Extension String...                |   |   |   |   |   |   |   |            |   |    |    |    |    |    |    |                              |    |    |    |    |    |    |    |    |    |    |    |    |    |    |    |
| OS UUID          | Operating System UUID              |   |   |   |   |   |   |   |            |   |    |    |    |    |    |    |                              |    |    |    |    |    |    |    |    |    |    |    |    |    |    |    |
|                  | Operating System UUID cont.        |   |   |   |   |   |   |   |            |   |    |    |    |    |    |    |                              |    |    |    |    |    |    |    |    |    |    |    |    |    |    |    |
|                  | Operating System UUID cont.        |   |   |   |   |   |   |   |            |   |    |    |    |    |    |    |                              |    |    |    |    |    |    |    |    |    |    |    |    |    |    |    |
|                  | Operating System UUID cont.        |   |   |   |   |   |   |   |            |   |    |    |    |    |    |    |                              |    |    |    |    |    |    |    |    |    |    |    |    |    |    |    |
| Device String    | String Block Type (0)              |   |   |   |   |   |   |   |            |   |    |    |    |    |    |    |                              |    |    |    |    |    |    |    |    |    |    |    |    |    |    |    |
|                  | String Block Length                |   |   |   |   |   |   |   |            |   |    |    |    |    |    |    |                              |    |    |    |    |    |    |    |    |    |    |    |    |    |    |    |
|                  | Device String...                   |   |   |   |   |   |   |   |            |   |    |    |    |    |    |    |                              |    |    |    |    |    |    |    |    |    |    |    |    |    |    |    |
| List of Fixes    | Mobile                             |   |   |   |   |   |   |   | Jailbroken |   |    |    |    |    |    |    | Generic List Block Type (31) |    |    |    |    |    |    |    |    |    |    |    |    |    |    |    |
|                  | Generic List Block Type (31) cont. |   |   |   |   |   |   |   |            |   |    |    |    |    |    |    | Generic List Block Length    |    |    |    |    |    |    |    |    |    |    |    |    |    |    |    |
|                  | Generic List Block Length cont.    |   |   |   |   |   |   |   |            |   |    |    |    |    |    |    | Fix List Data Blocks*        |    |    |    |    |    |    |    |    |    |    |    |    |    |    |    |
|                  | Fix List Data Blocks* cont.        |   |   |   |   |   |   |   |            |   |    |    |    |    |    |    |                              |    |    |    |    |    |    |    |    |    |    |    |    |    |    |    |

The following table describes the components of the User Product data block.

**Table 4-82** *User Product Data Block Fields*

| Field                                | Data Type | Description   |
|--------------------------------------|-----------|---|
| User Product Data Block Type         | uint32    | Initiates a User Product data block. This value is 134 for 5.1+.  |
| User Product Block Length            | uint32    | Total number of bytes in the User Product data block, including eight bytes for the user product block type and length fields, plus the number of bytes in the user product data that follows.  |
| Source ID                            | uint32    | Identification number that maps to the source that imported the data. Depending on the source type, this may map to RNA, a user, a scanner, or a third-party application.   |
| Source Type                          | uint32    | Number that maps to the type of data source: <ul style="list-style-type: none"> <li>• 0 if the data was provided by RNA</li> <li>• 1 if the data was provided by a user</li> <li>• 2 if the data was provided by a third-party scanner</li> <li>• 3 if the data was provided by a command line tool such as <code>nmimport.pl</code> or the Host Input API client</li> </ul>  |
| Generic List Block Type              | uint32    | Initiates a Generic List data block comprising IP Range Specification data blocks conveying IP address range data. This value is always 31.   |
| Generic List Block Length            | uint32    | Number of bytes in the Generic List data block, including the list header and all encapsulated IP Range Specification data blocks.  |
| IP Range Specification Data Blocks * | variable  | IP Range Specification data blocks containing information about the IP address ranges for the user input. See <a href="#">IP Address Range Data Block for 5.2+, page 4-88</a> for a description of this data block.   |
| Port                                 | uint16    | Port specified by the user.   |
| Protocol                             | uint16    | IANA protocol number or Ethertype. This is handled differently for Transport and Network layer protocols.<br><br>Transport layer protocols are identified by the IANA protocol number. For example: <ul style="list-style-type: none"> <li>• 6 — TCP</li> <li>• 17 — UDP</li> </ul> Network layer protocols are identified by the decimal form of the IEEE Registration Authority Ethertype. For example: <ul style="list-style-type: none"> <li>• 2048 — IP</li> </ul> |
| Drop User Product                    | uint32    | Indicates whether the user OS definition was deleted from the host: <ul style="list-style-type: none"> <li>• 0 — No</li> <li>• 1 — Yes</li> </ul>   |
| String Block Type                    | uint32    | Initiates a String data block containing the custom vendor name specified in the user input. This value is always 0.  |

Table 4-82 User Product Data Block Fields (continued)

| Field               | Data Type | Description  |
|---------------------|-----------|--|
| String Block Length | uint32    | Number of bytes in the custom vendor String data block, including eight bytes for the block type and length fields, plus the number of bytes in the vendor name.   |
| Custom Vendor Name  | string    | The custom vendor name specified in the user input.  |
| String Block Type   | uint32    | Initiates a String data block containing the custom product name specified in the user input. This value is always 0.  |
| String Block Length | uint32    | Number of bytes in the custom product String data block, including eight bytes for the block type and length fields, plus the number of bytes in the product name.   |
| Custom Product Name | string    | The custom product name specified in the user input.   |
| String Block Type   | uint32    | Initiates a String data block containing the custom version specified in the user input. This value is always 0.   |
| String Block Length | uint32    | Number of bytes in the custom version String data block, including eight bytes for the block type and length fields, plus the number of bytes in the version.  |
| Custom Version      | string    | The custom version specified in the user input.  |
| Software ID         | uint32    | The identifier for a specific revision of a server or operating system in the database.  |
| Server ID           | uint32    | The FireSIGHT System application identifier for the application protocol on the host server specified in user input.   |
| Vendor ID           | uint32    | The identifier for the vendor of a third-party operating system specified when the third-party operating system is mapped to a FireSIGHT System OS definition.   |
| Product ID          | uint32    | The product identification string of a third-party operating system string specified when the third-party operating system string is mapped to a FireSIGHT System OS definition.   |
| String Block Type   | uint32    | Initiates a String data block containing the major version number of the FireSIGHT System operating system definition that a third-party operating system string in the user input is mapped to. This value is always 0. |
| String Block Length | uint32    | Number of bytes in the major String data block, including eight bytes for the block type and length fields, plus the number of bytes in the version.   |
| Major Version       | string    | Major version of the FireSIGHT System operating system definition that a third-party OS string is mapped to.   |
| String Block Type   | uint32    | Initiates a String data block containing the minor version number of the FireSIGHT System operating system definition that a third-party OS string is mapped to. This value is always 0.                                 |
| String Block Length | uint32    | Number of bytes in the minor String data block, including eight bytes for the block type and length fields, plus the number of bytes in the version.   |



Table 4-82 User Product Data Block Fields (continued)

| Field               | Data Type | Description   |
|---------------------|-----------|---|
| Minor Version       | string    | Minor version number of the FireSIGHT System operating system definition that a third-party OS string in the user input is mapped to.   |
| String Block Type   | uint32    | Initiates a String data block containing the revision number of the FireSIGHT System operating system definition that a third-party operating system string in the user input is mapped to. This value is always 0. |
| String Block Length | uint32    | Number of bytes in the revision String data block, including eight bytes for the block type and length fields, plus the number of bytes in the revision number.   |
| Revision            | string    | Revision number of the FireSIGHT System operating system definition that a third-party OS string in the user input is mapped to.  |
| String Block Type   | uint32    | Initiates a String data block containing the last major version of the FireSIGHT System operating system definition that a third-party operating system string is mapped to. This value is always 0.                |
| String Block Length | uint32    | Number of bytes in the To Major String data block, including eight bytes for the block type and length fields, plus the number of bytes in the version.   |
| To Major            | string    | Last version number in a range of major version numbers of the FireSIGHT System operating system definition that a third-party OS string in the user input is mapped to.  |
| String Block Type   | uint32    | Initiates a String data block containing the last minor version of the FireSIGHT System operating system definition that a third-party operating system string is mapped to. This value is always 0.                |
| String Block Length | uint32    | Number of bytes in the To Minor String data block, including eight bytes for the block type and length fields, plus the number of bytes in the version.   |
| To Minor            | string    | Last version number in a range of minor version numbers of the FireSIGHT System operating system definition that a third-party OS string in the user input is mapped to.  |
| String Block Type   | uint32    | Initiates a String data block containing the Last revision number of the FireSIGHT System operating system definition that a third-party OS string is mapped to. This value is always 0.                            |
| String Block Length | uint32    | Number of bytes in the To Revision String data block, including eight bytes for the block type and length fields, plus the number of bytes in the revision number.  |
| To Revision         | string    | Last revision number in a range of revision numbers of the FireSIGHT System operating system definitions that a third-party OS string in the user input is mapped to.   |
| String Block Type   | uint32    | Initiates a String data block containing the build number of the FireSIGHT System operating system that the third-party OS string is mapped. This value is always 0.  |
| String Block Length | uint32    | Number of bytes in the build String data block, including eight bytes for the block type and length fields, plus the number of bytes in the build number.   |

Table 4-82 User Product Data Block Fields (continued)

| Field                     | Data Type   | Description  |
|---------------------------|-------------|--|
| Build                     | string      | Build number of the FireSIGHT System operating system that the third-party OS string in the user input is mapped to.   |
| String Block Type         | uint32      | Initiates a String data block containing the patch number of the FireSIGHT System operating system that the third-party OS string is mapped to. This value is always 0.                                    |
| String Block Length       | uint32      | Number of bytes in the patch String data block, including eight bytes for the block type and length fields, plus the number of bytes in the patch number.  |
| Patch                     | string      | Patch number of the FireSIGHT System operating system that the third-party OS string in the user input is mapped to.   |
| String Block Type         | uint32      | Initiates a String data block containing the extension number of the FireSIGHT System OS that the third-party operating system string is mapped. This value is always 0.                                   |
| String Block Length       | uint32      | Number of bytes in the extension String data block, including eight bytes for the block type and length fields, plus the number of bytes in the extension number.  |
| Extension                 | string      | Extension number of the FireSIGHT System operating system that the third-party OS string in the user input is mapped to.   |
| UUID                      | uint8 [x16] | Contains the unique identification number for the operating system.  |
| String Block Type         | uint32      | Initiates a String data block containing the device hardware information in the user input. This value is always 0.  |
| String Block Length       | uint32      | Number of bytes in the build String data block, including eight bytes for the block type and length fields, plus the number of bytes in the build number.  |
| Device String             | string      | Mobile device hardware information.  |
| Mobile                    | uint8       | A true-false flag indicating whether the operating system is running on a mobile device.   |
| Jailbroken                | uint8       | A true-false flag indicating whether the mobile device operating system is jailbroken.   |
| Generic List Block Type   | uint32      | Initiates a Generic List data block comprising Fix List data blocks conveying user input data regarding what fixes have been applied to hosts in the specified IP address ranges. This value is always 31. |
| Generic List Block Length | uint32      | Number of bytes in the Generic List data block, including the list header and all encapsulated Fix List data blocks.   |
| Fix List Data Blocks *    | variable    | Fix List data blocks containing information about fixes applied to the hosts. See <a href="#">Fix List Data Block, page 4-95</a> for a description of this data block.                                     |

# User Data Blocks

User data blocks appear in user event messages. They are a subset of the series 1 data blocks. For information on the general format of series 1 data blocks, see [Understanding Discovery \(Series 1\) Blocks, page 4-55](#).



Note

The data block length field of the user data block header contains the number of bytes in the data block, including the eight bytes of the two data block header fields.

The following table lists the user data blocks that can appear in user event messages. Data blocks are listed by data block type. Current data blocks are the latest versions. Legacy blocks are supported but not produced by the current version of the FireSIGHT System.

**Table 4-83** *User Data Block Type*

| Type | Content                           | Data Block Category | Description   |
|------|-----------------------------------|---------------------|---|
| 73   | User Login Information            | Legacy              | Contains changes in login information for users detected by the system. See <a href="#">User Login Information Data Block 5.1+, page 4-171</a> for more information. The successor block type introduced for version 5.0 has the same structure as block type 73 but with different data in the fields.   |
| 74   | User Account Update Message       | Current             | Contains changes in user account information. See <a href="#">User Account Update Message Data Block, page 4-160</a> for more information.  |
| 75   | User Information for 4.7 - 4.10.x | Legacy              | Contains changes in information for users detected by the system. See <a href="#">User Information Data Block, page 4-168</a> for more information. The successor block type 120 introduced for version 5.0 has the same structure as block type 75.  |
| 120  | User Information for 5.0+         | Current             | Contains changes in information for users detected by the system. See <a href="#">User Information Data Block, page 4-168</a> for more information. Supersedes block type 75.   |
| 121  | User Login Information            | Legacy              | Contains changes in login information for users detected by the system. See <a href="#">User Login Information Data Block for 5.0 - 5.0.2, page B-68</a> for more information. Differs from block 73 in the content of the Protocol field, which stores the Version 5.0+ application ID for the application protocol ID detected in the event. The successor block introduced for version 5.1 has block type 127. |
| 127  | User Login Information            | Current             | Contains changes in login information for users detected by the system. See <a href="#">User Login Information Data Block 5.1+, page 4-171</a> for more information. It supersedes block type 121.  |
| 150  | IOC State                         | Current             | Contains information about compromises. See <a href="#">, page 3-77</a> for more information.   |

## User Account Update Message Data Block

The User Account Update Message data block conveys information about updates to a user’s account information.

The User Account Update Message data block has a block type of 74 in the series 1 group of blocks.

The following diagram shows the format of the User Account Update Message data block:

| Byte            | 0   |   |   |   |   |   |   |   | 1 |   |    |    |    |    |    |    | 2  |    |    |    |    |    |    |    | 3  |    |    |    |    |    |    |    |
|-----------------|---|---|---|---|---|---|---|---|---|---|----|----|----|----|----|----|----|----|----|----|----|----|----|----|----|----|----|----|----|----|----|----|
| Bit             | 0   | 1 | 2 | 3 | 4 | 5 | 6 | 7 | 8 | 9 | 10 | 11 | 12 | 13 | 14 | 15 | 16 | 17 | 18 | 19 | 20 | 21 | 22 | 23 | 24 | 25 | 26 | 27 | 28 | 29 | 30 | 31 |
|                 | User Account Update Message Block Type (74) |   |   |   |   |   |   |   |   |   |    |    |    |    |    |    |    |    |    |    |    |    |    |    |    |    |    |    |    |    |    |    |
|                 | User Account Update Message Block Length    |   |   |   |   |   |   |   |   |   |    |    |    |    |    |    |    |    |    |    |    |    |    |    |    |    |    |    |    |    |    |    |
| User Name       | String Block Type (0)                       |   |   |   |   |   |   |   |   |   |    |    |    |    |    |    |    |    |    |    |    |    |    |    |    |    |    |    |    |    |    |    |
|                 | String Block Length                         |   |   |   |   |   |   |   |   |   |    |    |    |    |    |    |    |    |    |    |    |    |    |    |    |    |    |    |    |    |    |    |
|                 | User Name...                                |   |   |   |   |   |   |   |   |   |    |    |    |    |    |    |    |    |    |    |    |    |    |    |    |    |    |    |    |    |    |    |
| First Name      | String Block Type (0)                       |   |   |   |   |   |   |   |   |   |    |    |    |    |    |    |    |    |    |    |    |    |    |    |    |    |    |    |    |    |    |    |
|                 | String Block Length                         |   |   |   |   |   |   |   |   |   |    |    |    |    |    |    |    |    |    |    |    |    |    |    |    |    |    |    |    |    |    |    |
|                 | First Name...                               |   |   |   |   |   |   |   |   |   |    |    |    |    |    |    |    |    |    |    |    |    |    |    |    |    |    |    |    |    |    |    |
| Middle Initials | String Block Type (0)                       |   |   |   |   |   |   |   |   |   |    |    |    |    |    |    |    |    |    |    |    |    |    |    |    |    |    |    |    |    |    |    |
|                 | String Block Length                         |   |   |   |   |   |   |   |   |   |    |    |    |    |    |    |    |    |    |    |    |    |    |    |    |    |    |    |    |    |    |    |
|                 | Middle Initials...                          |   |   |   |   |   |   |   |   |   |    |    |    |    |    |    |    |    |    |    |    |    |    |    |    |    |    |    |    |    |    |    |
| Last Name       | String Block Type (0)                       |   |   |   |   |   |   |   |   |   |    |    |    |    |    |    |    |    |    |    |    |    |    |    |    |    |    |    |    |    |    |    |
|                 | String Block Length                         |   |   |   |   |   |   |   |   |   |    |    |    |    |    |    |    |    |    |    |    |    |    |    |    |    |    |    |    |    |    |    |
|                 | Last Name...                                |   |   |   |   |   |   |   |   |   |    |    |    |    |    |    |    |    |    |    |    |    |    |    |    |    |    |    |    |    |    |    |
| Full Name       | String Block Type (0)                       |   |   |   |   |   |   |   |   |   |    |    |    |    |    |    |    |    |    |    |    |    |    |    |    |    |    |    |    |    |    |    |
|                 | String Block Length                         |   |   |   |   |   |   |   |   |   |    |    |    |    |    |    |    |    |    |    |    |    |    |    |    |    |    |    |    |    |    |    |
|                 | Full Name...                                |   |   |   |   |   |   |   |   |   |    |    |    |    |    |    |    |    |    |    |    |    |    |    |    |    |    |    |    |    |    |    |
| Title           | String Block Type (0)                       |   |   |   |   |   |   |   |   |   |    |    |    |    |    |    |    |    |    |    |    |    |    |    |    |    |    |    |    |    |    |    |
|                 | String Block Length                         |   |   |   |   |   |   |   |   |   |    |    |    |    |    |    |    |    |    |    |    |    |    |    |    |    |    |    |    |    |    |    |
|                 | Title...                                    |   |   |   |   |   |   |   |   |   |    |    |    |    |    |    |    |    |    |    |    |    |    |    |    |    |    |    |    |    |    |    |

| Byte               | 0                     |   |   |   |   |   |   |   | 1 |   |    |    |    |    |    |    | 2  |    |    |    |    |    |    |    | 3  |    |    |    |    |    |    |    |
|--------------------|-----------------------|---|---|---|---|---|---|---|---|---|----|----|----|----|----|----|----|----|----|----|----|----|----|----|----|----|----|----|----|----|----|----|
|                    | 0                     | 1 | 2 | 3 | 4 | 5 | 6 | 7 | 8 | 9 | 10 | 11 | 12 | 13 | 14 | 15 | 16 | 17 | 18 | 19 | 20 | 21 | 22 | 23 | 24 | 25 | 26 | 27 | 28 | 29 | 30 | 31 |
| Staff Identity     | String Block Type (0) |   |   |   |   |   |   |   |   |   |    |    |    |    |    |    |    |    |    |    |    |    |    |    |    |    |    |    |    |    |    |    |
|                    | String Block Length   |   |   |   |   |   |   |   |   |   |    |    |    |    |    |    |    |    |    |    |    |    |    |    |    |    |    |    |    |    |    |    |
|                    | Staff Identity...     |   |   |   |   |   |   |   |   |   |    |    |    |    |    |    |    |    |    |    |    |    |    |    |    |    |    |    |    |    |    |    |
| Address            | String Block Type (0) |   |   |   |   |   |   |   |   |   |    |    |    |    |    |    |    |    |    |    |    |    |    |    |    |    |    |    |    |    |    |    |
|                    | String Block Length   |   |   |   |   |   |   |   |   |   |    |    |    |    |    |    |    |    |    |    |    |    |    |    |    |    |    |    |    |    |    |    |
|                    | Address...            |   |   |   |   |   |   |   |   |   |    |    |    |    |    |    |    |    |    |    |    |    |    |    |    |    |    |    |    |    |    |    |
| City               | String Block Type (0) |   |   |   |   |   |   |   |   |   |    |    |    |    |    |    |    |    |    |    |    |    |    |    |    |    |    |    |    |    |    |    |
|                    | String Block Length   |   |   |   |   |   |   |   |   |   |    |    |    |    |    |    |    |    |    |    |    |    |    |    |    |    |    |    |    |    |    |    |
|                    | City...               |   |   |   |   |   |   |   |   |   |    |    |    |    |    |    |    |    |    |    |    |    |    |    |    |    |    |    |    |    |    |    |
| State              | String Block Type (0) |   |   |   |   |   |   |   |   |   |    |    |    |    |    |    |    |    |    |    |    |    |    |    |    |    |    |    |    |    |    |    |
|                    | String Block Length   |   |   |   |   |   |   |   |   |   |    |    |    |    |    |    |    |    |    |    |    |    |    |    |    |    |    |    |    |    |    |    |
|                    | State...              |   |   |   |   |   |   |   |   |   |    |    |    |    |    |    |    |    |    |    |    |    |    |    |    |    |    |    |    |    |    |    |
| Country/<br>Region | String Block Type (0) |   |   |   |   |   |   |   |   |   |    |    |    |    |    |    |    |    |    |    |    |    |    |    |    |    |    |    |    |    |    |    |
|                    | String Block Length   |   |   |   |   |   |   |   |   |   |    |    |    |    |    |    |    |    |    |    |    |    |    |    |    |    |    |    |    |    |    |    |
|                    | Country/Region...     |   |   |   |   |   |   |   |   |   |    |    |    |    |    |    |    |    |    |    |    |    |    |    |    |    |    |    |    |    |    |    |
| Postal Code        | String Block Type (0) |   |   |   |   |   |   |   |   |   |    |    |    |    |    |    |    |    |    |    |    |    |    |    |    |    |    |    |    |    |    |    |
|                    | String Block Length   |   |   |   |   |   |   |   |   |   |    |    |    |    |    |    |    |    |    |    |    |    |    |    |    |    |    |    |    |    |    |    |
|                    | Postal Code...        |   |   |   |   |   |   |   |   |   |    |    |    |    |    |    |    |    |    |    |    |    |    |    |    |    |    |    |    |    |    |    |
| Building           | String Block Type (0) |   |   |   |   |   |   |   |   |   |    |    |    |    |    |    |    |    |    |    |    |    |    |    |    |    |    |    |    |    |    |    |
|                    | String Block Length   |   |   |   |   |   |   |   |   |   |    |    |    |    |    |    |    |    |    |    |    |    |    |    |    |    |    |    |    |    |    |    |
|                    | Building...           |   |   |   |   |   |   |   |   |   |    |    |    |    |    |    |    |    |    |    |    |    |    |    |    |    |    |    |    |    |    |    |
| Location           | String Block Type (0) |   |   |   |   |   |   |   |   |   |    |    |    |    |    |    |    |    |    |    |    |    |    |    |    |    |    |    |    |    |    |    |
|                    | String Block Length   |   |   |   |   |   |   |   |   |   |    |    |    |    |    |    |    |    |    |    |    |    |    |    |    |    |    |    |    |    |    |    |
|                    | Location...           |   |   |   |   |   |   |   |   |   |    |    |    |    |    |    |    |    |    |    |    |    |    |    |    |    |    |    |    |    |    |    |

| Byte     | 0                     |   |   |   |   |   |   |   | 1 |   |    |    |    |    |    |    | 2  |    |    |    |    |    |    |    | 3  |    |    |    |    |    |    |    |
|----------|-----------------------|---|---|---|---|---|---|---|---|---|----|----|----|----|----|----|----|----|----|----|----|----|----|----|----|----|----|----|----|----|----|----|
|          | 0                     | 1 | 2 | 3 | 4 | 5 | 6 | 7 | 8 | 9 | 10 | 11 | 12 | 13 | 14 | 15 | 16 | 17 | 18 | 19 | 20 | 21 | 22 | 23 | 24 | 25 | 26 | 27 | 28 | 29 | 30 | 31 |
| Room     | String Block Type (0) |   |   |   |   |   |   |   |   |   |    |    |    |    |    |    |    |    |    |    |    |    |    |    |    |    |    |    |    |    |    |    |
|          | String Block Length   |   |   |   |   |   |   |   |   |   |    |    |    |    |    |    |    |    |    |    |    |    |    |    |    |    |    |    |    |    |    |    |
|          | Room...               |   |   |   |   |   |   |   |   |   |    |    |    |    |    |    |    |    |    |    |    |    |    |    |    |    |    |    |    |    |    |    |
| Company  | String Block Type (0) |   |   |   |   |   |   |   |   |   |    |    |    |    |    |    |    |    |    |    |    |    |    |    |    |    |    |    |    |    |    |    |
|          | String Block Length   |   |   |   |   |   |   |   |   |   |    |    |    |    |    |    |    |    |    |    |    |    |    |    |    |    |    |    |    |    |    |    |
|          | Company...            |   |   |   |   |   |   |   |   |   |    |    |    |    |    |    |    |    |    |    |    |    |    |    |    |    |    |    |    |    |    |    |
| Division | String Block Type (0) |   |   |   |   |   |   |   |   |   |    |    |    |    |    |    |    |    |    |    |    |    |    |    |    |    |    |    |    |    |    |    |
|          | String Block Length   |   |   |   |   |   |   |   |   |   |    |    |    |    |    |    |    |    |    |    |    |    |    |    |    |    |    |    |    |    |    |    |
|          | Division...           |   |   |   |   |   |   |   |   |   |    |    |    |    |    |    |    |    |    |    |    |    |    |    |    |    |    |    |    |    |    |    |
| Dept     | String Block Type (0) |   |   |   |   |   |   |   |   |   |    |    |    |    |    |    |    |    |    |    |    |    |    |    |    |    |    |    |    |    |    |    |
|          | String Block Length   |   |   |   |   |   |   |   |   |   |    |    |    |    |    |    |    |    |    |    |    |    |    |    |    |    |    |    |    |    |    |    |
|          | Department...         |   |   |   |   |   |   |   |   |   |    |    |    |    |    |    |    |    |    |    |    |    |    |    |    |    |    |    |    |    |    |    |
| Office   | String Block Type (0) |   |   |   |   |   |   |   |   |   |    |    |    |    |    |    |    |    |    |    |    |    |    |    |    |    |    |    |    |    |    |    |
|          | String Block Length   |   |   |   |   |   |   |   |   |   |    |    |    |    |    |    |    |    |    |    |    |    |    |    |    |    |    |    |    |    |    |    |
|          | Office...             |   |   |   |   |   |   |   |   |   |    |    |    |    |    |    |    |    |    |    |    |    |    |    |    |    |    |    |    |    |    |    |
| Mailstop | String Block Type (0) |   |   |   |   |   |   |   |   |   |    |    |    |    |    |    |    |    |    |    |    |    |    |    |    |    |    |    |    |    |    |    |
|          | String Block Length   |   |   |   |   |   |   |   |   |   |    |    |    |    |    |    |    |    |    |    |    |    |    |    |    |    |    |    |    |    |    |    |
|          | Mailstop...           |   |   |   |   |   |   |   |   |   |    |    |    |    |    |    |    |    |    |    |    |    |    |    |    |    |    |    |    |    |    |    |
| Email    | String Block Type (0) |   |   |   |   |   |   |   |   |   |    |    |    |    |    |    |    |    |    |    |    |    |    |    |    |    |    |    |    |    |    |    |
|          | String Block Length   |   |   |   |   |   |   |   |   |   |    |    |    |    |    |    |    |    |    |    |    |    |    |    |    |    |    |    |    |    |    |    |
|          | Email...              |   |   |   |   |   |   |   |   |   |    |    |    |    |    |    |    |    |    |    |    |    |    |    |    |    |    |    |    |    |    |    |
| Phone    | String Block Type (0) |   |   |   |   |   |   |   |   |   |    |    |    |    |    |    |    |    |    |    |    |    |    |    |    |    |    |    |    |    |    |    |
|          | String Block Length   |   |   |   |   |   |   |   |   |   |    |    |    |    |    |    |    |    |    |    |    |    |    |    |    |    |    |    |    |    |    |    |
|          | Phone...              |   |   |   |   |   |   |   |   |   |    |    |    |    |    |    |    |    |    |    |    |    |    |    |    |    |    |    |    |    |    |    |

| Byte          | 0                     |   |   |   |   |   |   |   | 1 |   |    |    |    |    |    |    | 2  |    |    |    |    |    |    |    | 3  |    |    |    |    |    |    |    |
|---------------|-----------------------|---|---|---|---|---|---|---|---|---|----|----|----|----|----|----|----|----|----|----|----|----|----|----|----|----|----|----|----|----|----|----|
|               | 0                     | 1 | 2 | 3 | 4 | 5 | 6 | 7 | 8 | 9 | 10 | 11 | 12 | 13 | 14 | 15 | 16 | 17 | 18 | 19 | 20 | 21 | 22 | 23 | 24 | 25 | 26 | 27 | 28 | 29 | 30 | 31 |
| IP Phone      | String Block Type (0) |   |   |   |   |   |   |   |   |   |    |    |    |    |    |    |    |    |    |    |    |    |    |    |    |    |    |    |    |    |    |    |
|               | String Block Length   |   |   |   |   |   |   |   |   |   |    |    |    |    |    |    |    |    |    |    |    |    |    |    |    |    |    |    |    |    |    |    |
|               | IP Phone...           |   |   |   |   |   |   |   |   |   |    |    |    |    |    |    |    |    |    |    |    |    |    |    |    |    |    |    |    |    |    |    |
| User 1        | String Block Type (0) |   |   |   |   |   |   |   |   |   |    |    |    |    |    |    |    |    |    |    |    |    |    |    |    |    |    |    |    |    |    |    |
|               | String Block Length   |   |   |   |   |   |   |   |   |   |    |    |    |    |    |    |    |    |    |    |    |    |    |    |    |    |    |    |    |    |    |    |
|               | User 1...             |   |   |   |   |   |   |   |   |   |    |    |    |    |    |    |    |    |    |    |    |    |    |    |    |    |    |    |    |    |    |    |
| User 2        | String Block Type (0) |   |   |   |   |   |   |   |   |   |    |    |    |    |    |    |    |    |    |    |    |    |    |    |    |    |    |    |    |    |    |    |
|               | String Block Length   |   |   |   |   |   |   |   |   |   |    |    |    |    |    |    |    |    |    |    |    |    |    |    |    |    |    |    |    |    |    |    |
|               | User 2...             |   |   |   |   |   |   |   |   |   |    |    |    |    |    |    |    |    |    |    |    |    |    |    |    |    |    |    |    |    |    |    |
| User 3        | String Block Type (0) |   |   |   |   |   |   |   |   |   |    |    |    |    |    |    |    |    |    |    |    |    |    |    |    |    |    |    |    |    |    |    |
|               | String Block Length   |   |   |   |   |   |   |   |   |   |    |    |    |    |    |    |    |    |    |    |    |    |    |    |    |    |    |    |    |    |    |    |
|               | User 3...             |   |   |   |   |   |   |   |   |   |    |    |    |    |    |    |    |    |    |    |    |    |    |    |    |    |    |    |    |    |    |    |
| User 4        | String Block Type (0) |   |   |   |   |   |   |   |   |   |    |    |    |    |    |    |    |    |    |    |    |    |    |    |    |    |    |    |    |    |    |    |
|               | String Block Length   |   |   |   |   |   |   |   |   |   |    |    |    |    |    |    |    |    |    |    |    |    |    |    |    |    |    |    |    |    |    |    |
|               | User 4...             |   |   |   |   |   |   |   |   |   |    |    |    |    |    |    |    |    |    |    |    |    |    |    |    |    |    |    |    |    |    |    |
| Email Alias 1 | String Block Type (0) |   |   |   |   |   |   |   |   |   |    |    |    |    |    |    |    |    |    |    |    |    |    |    |    |    |    |    |    |    |    |    |
|               | String Block Length   |   |   |   |   |   |   |   |   |   |    |    |    |    |    |    |    |    |    |    |    |    |    |    |    |    |    |    |    |    |    |    |
|               | Email Alias 1...      |   |   |   |   |   |   |   |   |   |    |    |    |    |    |    |    |    |    |    |    |    |    |    |    |    |    |    |    |    |    |    |
| Email Alias 2 | String Block Type (0) |   |   |   |   |   |   |   |   |   |    |    |    |    |    |    |    |    |    |    |    |    |    |    |    |    |    |    |    |    |    |    |
|               | String Block Length   |   |   |   |   |   |   |   |   |   |    |    |    |    |    |    |    |    |    |    |    |    |    |    |    |    |    |    |    |    |    |    |
|               | Email Alias 2...      |   |   |   |   |   |   |   |   |   |    |    |    |    |    |    |    |    |    |    |    |    |    |    |    |    |    |    |    |    |    |    |
| Email Alias 3 | String Block Type (0) |   |   |   |   |   |   |   |   |   |    |    |    |    |    |    |    |    |    |    |    |    |    |    |    |    |    |    |    |    |    |    |
|               | String Block Length   |   |   |   |   |   |   |   |   |   |    |    |    |    |    |    |    |    |    |    |    |    |    |    |    |    |    |    |    |    |    |    |
|               | Email Alias 3...      |   |   |   |   |   |   |   |   |   |    |    |    |    |    |    |    |    |    |    |    |    |    |    |    |    |    |    |    |    |    |    |

The following table describes the components of the User Account Update Message data block.

**Table 4-84** *User Account Update Message Data Block Fields*

| Field                                    | Data Type | Description   |
|--|-----------|---|
| User Account Update Message Block Type   | uint32    | Initiates a User Account Update Message data block. This value is always 74.  |
| User Account Update Message Block Length | uint32    | Total number of bytes in the User Account Update Message data block, including eight bytes for the user account update message block type and length fields, plus the number of bytes in the user account update message data that follows. |
| String Block Type                        | uint32    | Initiates a String data block containing the username for the user. This value is always 0.   |
| String Block Length                      | uint32    | Number of bytes in the username String data block, including eight bytes for the block type and length fields, plus the number of bytes in the username.  |
| Username                                 | string    | The username for the user.  |
| String Block Type                        | uint32    | Initiates a String data block containing the first name for the user. This value is always 0.   |
| String Block Length                      | uint32    | Number of bytes in the first name String data block, including eight bytes for the block type and length fields, plus the number of bytes in the first name.  |
| First Name                               | string    | The first name for the user.  |
| String Block Type                        | uint32    | Initiates a String data block containing the middle initials for the user. This value is always 0.  |
| String Block Length                      | uint32    | Number of bytes in the middle initials String data block, including eight bytes for the block type and length fields, plus the number of bytes in the middle initials.  |
| Middle Initials                          | string    | The middle initials for the user.   |
| String Block Type                        | uint32    | Initiates a String data block containing the last name for the user. This value is always 0.  |
| String Block Length                      | uint32    | Number of bytes in the last name String data block, including eight bytes for the block type and length fields, plus the number of bytes in the last name.  |
| Last Name                                | string    | The last name for the user.   |
| String Block Type                        | uint32    | Initiates a String data block containing the full name for the user. This value is always 0.  |
| String Block Length                      | uint32    | Number of bytes in the full name String data block, including eight bytes for the block type and length fields, plus the number of bytes in the full name.  |
| Full Name                                | string    | The full name for the user.   |
| String Block Type                        | uint32    | Initiates a String data block containing the title for the user. This value is always 0.  |



Table 4-84 User Account Update Message Data Block Fields (continued)

| Field               | Data Type | Description  |
|---------------------|-----------|--|
| String Block Length | uint32    | Number of bytes in the title String data block, including eight bytes for the block type and length fields, plus the number of bytes in the title.                         |
| Title               | string    | The title for the user.  |
| String Block Type   | uint32    | Initiates a String data block containing the staff identification for the user. This value is always 0.  |
| String Block Length | uint32    | Number of bytes in the staff identity String data block, including eight bytes for the block type and length fields, plus the number of bytes in the staff identity.       |
| Staff Identity      | string    | The staff identity for the user.   |
| String Block Type   | uint32    | Initiates a String data block containing the address for the user. This value is always 0.   |
| String Block Length | uint32    | Number of bytes in the address String data block, including eight bytes for the block type and length fields, plus the number of bytes in the address.                     |
| Address             | string    | The address for the user.  |
| String Block Type   | uint32    | Initiates a String data block containing the city from the user's address. This value is always 0.   |
| String Block Length | uint32    | Number of bytes in the city String data block, including eight bytes for the block type and length fields, plus the number of bytes in the city.                           |
| City                | string    | The city from the user's address.  |
| String Block Type   | uint32    | Initiates a String data block containing the state from the user's address. This value is always 0.  |
| String Block Length | uint32    | Number of bytes in the state String data block, including eight bytes for the block type and length fields, plus the number of bytes in the state.                         |
| State               | string    | The state for the user.  |
| String Block Type   | uint32    | Initiates a String data block containing the country or region from the user's address. This value is always 0.  |
| String Block Length | uint32    | Number of bytes in the country or region String data block, including eight bytes for the block type and length fields, plus the number of bytes in the country or region. |
| Country or Region   | string    | The country or region from the user's address.   |
| String Block Type   | uint32    | Initiates a String data block containing the postal code from the user's address. This value is always 0.  |
| String Block Length | uint32    | Number of bytes in the postal code String data block, including eight bytes for the block type and length fields, plus the number of bytes in the postal code.             |
| Postal Code         | string    | The postal code from the user's address.   |

Table 4-84 User Account Update Message Data Block Fields (continued)

| Field               | Data Type | Description   |
|---------------------|-----------|---|
| String Block Type   | uint32    | Initiates a String data block containing the building from the user's address. This value is always 0.  |
| String Block Length | uint32    | Number of bytes in the building String data block, including eight bytes for the block type and length fields, plus the number of bytes in the building name. |
| Building            | string    | The building from the user's address.   |
| String Block Type   | uint32    | Initiates a String data block containing the location from the user's address. This value is always 0.  |
| String Block Length | uint32    | Number of bytes in the location String data block, including eight bytes for the block type and length fields, plus the number of bytes in the location name. |
| Location            | string    | The location from the user's address.   |
| String Block Type   | uint32    | Initiates a String data block containing the room from the user's address. This value is always 0.  |
| String Block Length | uint32    | Number of bytes in the room String data block, including eight bytes for the block type and length fields, plus the number of bytes in the room.              |
| Room                | string    | The room from the user's address.   |
| String Block Type   | uint32    | Initiates a String data block containing the company from the user's address. This value is always 0.   |
| String Block Length | uint32    | Number of bytes in the company String data block, including eight bytes for the block type and length fields, plus the number of bytes in the company name.   |
| Company             | string    | The company from the user's address.  |
| String Block Type   | uint32    | Initiates a String data block containing the division from the user's address. This value is always 0.  |
| String Block Length | uint32    | Number of bytes in the division String data block, including eight bytes for the block type and length fields, plus the number of bytes in the division name. |
| Division            | string    | The division from the user's address.   |
| String Block Type   | uint32    | Initiates a String data block containing the department from the user's address. This value is always 0.  |
| String Block Length | uint32    | Number of bytes in the department String data block, including eight bytes for the block type and length fields, plus the number of bytes in the department.  |
| Department          | string    | The department from the user's address.   |
| String Block Type   | uint32    | Initiates a String data block containing the office from the user's address. This value is always 0.  |
| String Block Length | uint32    | Number of bytes in the office String data block, including eight bytes for the block type and length fields, plus the number of bytes in the office.          |
| Office              | string    | The office from the user's address.   |

Table 4-84 User Account Update Message Data Block Fields (continued)

| Field               | Data Type | Description  |
|---------------------|-----------|--|
| String Block Type   | uint32    | Initiates a String data block containing the mailstop from the user's address. This value is always 0.   |
| String Block Length | uint32    | Number of bytes in the mailstop String data block, including eight bytes for the block type and length fields, plus the number of bytes in the mailstop.                           |
| Mailstop            | string    | The mailstop from the user's address.  |
| String Block Type   | uint32    | Initiates a String data block containing the email address for the user. This value is always 0.   |
| String Block Length | uint32    | Number of bytes in the email address String data block, including eight bytes for the block type and length fields, plus the number of bytes in the email address.                 |
| Email               | string    | The email address for the user.  |
| String Block Type   | uint32    | Initiates a String data block containing the phone number for the user. This value is always 0.  |
| String Block Length | uint32    | Number of bytes in the phone number String data block, including eight bytes for the block type and length fields, plus the number of bytes in the phone number.                   |
| Phone               | string    | The phone number for the user.   |
| String Block Type   | uint32    | Initiates a String data block containing the Internet phone number for the user. This value is always 0.   |
| String Block Length | uint32    | Number of bytes in the Internet phone number String data block, including eight bytes for the block type and length fields, plus the number of bytes in the Internet phone number. |
| Internet Phone      | string    | The Internet phone number for the user.  |
| String Block Type   | uint32    | Initiates a String data block containing an alternate user name for the user. This value is always 0.  |
| String Block Length | uint32    | Number of bytes in the user String data block, including eight bytes for the block type and length fields, plus the number of bytes in the username.                               |
| User 1              | string    | An alternate user name for the user.   |
| String Block Type   | uint32    | Initiates a String data block containing an alternate user name for the user. This value is always 0.  |
| String Block Length | uint32    | Number of bytes in the user String data block, including eight bytes for the block type and length fields, plus the number of bytes in the username.                               |
| User 2              | string    | An alternate user name for the user.   |
| String Block Type   | uint32    | Initiates a String data block containing an alternate user name for the user. This value is always 0.  |
| String Block Length | uint32    | Number of bytes in the user String data block, including eight bytes for the block type and length fields, plus the number of bytes in the username.                               |
| User 3              | string    | An alternate user name for the user.   |

Table 4-84 User Account Update Message Data Block Fields (continued)

| Field               | Data Type | Description  |
|---------------------|-----------|--|
| String Block Type   | uint32    | Initiates a String data block containing an alternate user name for the user. This value is always 0.  |
| String Block Length | uint32    | Number of bytes in the user String data block, including eight bytes for the block type and length fields, plus the number of bytes in the username.           |
| User 4              | string    | An alternate user name for the user.   |
| String Block Type   | uint32    | Initiates a String data block containing an email alias for the user. This value is always 0.  |
| String Block Length | uint32    | Number of bytes in the email alias String data block, including eight bytes for the block type and length fields, plus the number of bytes in the email alias. |
| Email alias 1       | string    | An email alias for the user.   |
| String Block Type   | uint32    | Initiates a String data block containing an email alias for the user. This value is always 0.  |
| String Block Length | uint32    | Number of bytes in the email alias String data block, including eight bytes for the block type and length fields, plus the number of bytes in the email alias. |
| Email alias 2       | string    | An email alias for the user.   |
| String Block Type   | uint32    | Initiates a String data block containing an email alias for the user. This value is always 0.  |
| String Block Length | uint32    | Number of bytes in the email alias String data block, including eight bytes for the block type and length fields, plus the number of bytes in the email alias. |
| Email alias 3       | string    | An email alias for the user.   |

## User Information Data Block

The User Information data block is used in User Modification messages and conveys information for a user detected, removed, or dropped. For more information, see [User Modification Messages, page 4-54](#)

The User Information data block has a block type of 75 in the series 1 group of blocks for version 4.7 - 4.10.x and a block type of 120 in the series 1 group of blocks for 5.0+. The structures are the same for block types 75 and 120.

The following diagram shows the format of the User Information data block:

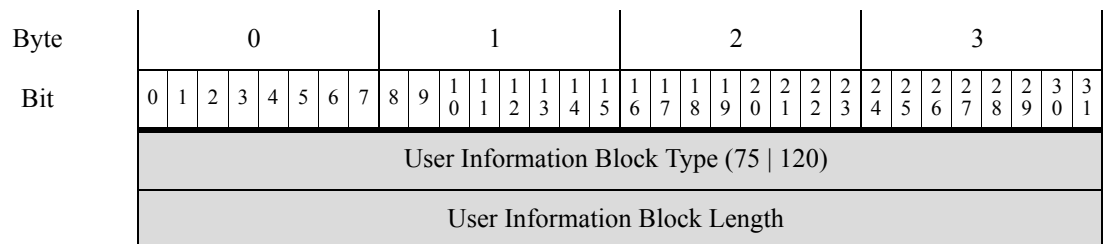

| Byte       | 0                     |   |   |   |   |   |   |   | 1 |   |    |    |    |    |    |    | 2  |    |    |    |    |    |    |    | 3  |    |    |    |    |    |    |    |
|------------|-----------------------|---|---|---|---|---|---|---|---|---|----|----|----|----|----|----|----|----|----|----|----|----|----|----|----|----|----|----|----|----|----|----|
| Bit        | 0                     | 1 | 2 | 3 | 4 | 5 | 6 | 7 | 8 | 9 | 10 | 11 | 12 | 13 | 14 | 15 | 16 | 17 | 18 | 19 | 20 | 21 | 22 | 23 | 24 | 25 | 26 | 27 | 28 | 29 | 30 | 31 |
|            | User ID               |   |   |   |   |   |   |   |   |   |    |    |    |    |    |    |    |    |    |    |    |    |    |    |    |    |    |    |    |    |    |    |
| User Name  | String Block Type (0) |   |   |   |   |   |   |   |   |   |    |    |    |    |    |    |    |    |    |    |    |    |    |    |    |    |    |    |    |    |    |    |
|            | String Block Length   |   |   |   |   |   |   |   |   |   |    |    |    |    |    |    |    |    |    |    |    |    |    |    |    |    |    |    |    |    |    |    |
|            | User Name...          |   |   |   |   |   |   |   |   |   |    |    |    |    |    |    |    |    |    |    |    |    |    |    |    |    |    |    |    |    |    |    |
|            | Protocol              |   |   |   |   |   |   |   |   |   |    |    |    |    |    |    |    |    |    |    |    |    |    |    |    |    |    |    |    |    |    |    |
| First Name | String Block Type (0) |   |   |   |   |   |   |   |   |   |    |    |    |    |    |    |    |    |    |    |    |    |    |    |    |    |    |    |    |    |    |    |
|            | String Block Length   |   |   |   |   |   |   |   |   |   |    |    |    |    |    |    |    |    |    |    |    |    |    |    |    |    |    |    |    |    |    |    |
|            | First Name...         |   |   |   |   |   |   |   |   |   |    |    |    |    |    |    |    |    |    |    |    |    |    |    |    |    |    |    |    |    |    |    |
| Last Name  | String Block Type (0) |   |   |   |   |   |   |   |   |   |    |    |    |    |    |    |    |    |    |    |    |    |    |    |    |    |    |    |    |    |    |    |
|            | String Block Length   |   |   |   |   |   |   |   |   |   |    |    |    |    |    |    |    |    |    |    |    |    |    |    |    |    |    |    |    |    |    |    |
|            | Last Name...          |   |   |   |   |   |   |   |   |   |    |    |    |    |    |    |    |    |    |    |    |    |    |    |    |    |    |    |    |    |    |    |
| Email      | String Block Type (0) |   |   |   |   |   |   |   |   |   |    |    |    |    |    |    |    |    |    |    |    |    |    |    |    |    |    |    |    |    |    |    |
|            | String Block Length   |   |   |   |   |   |   |   |   |   |    |    |    |    |    |    |    |    |    |    |    |    |    |    |    |    |    |    |    |    |    |    |
|            | Email...              |   |   |   |   |   |   |   |   |   |    |    |    |    |    |    |    |    |    |    |    |    |    |    |    |    |    |    |    |    |    |    |
| Department | String Block Type (0) |   |   |   |   |   |   |   |   |   |    |    |    |    |    |    |    |    |    |    |    |    |    |    |    |    |    |    |    |    |    |    |
|            | String Block Length   |   |   |   |   |   |   |   |   |   |    |    |    |    |    |    |    |    |    |    |    |    |    |    |    |    |    |    |    |    |    |    |
|            | Department...         |   |   |   |   |   |   |   |   |   |    |    |    |    |    |    |    |    |    |    |    |    |    |    |    |    |    |    |    |    |    |    |
| Phone      | String Block Type (0) |   |   |   |   |   |   |   |   |   |    |    |    |    |    |    |    |    |    |    |    |    |    |    |    |    |    |    |    |    |    |    |
|            | String Block Length   |   |   |   |   |   |   |   |   |   |    |    |    |    |    |    |    |    |    |    |    |    |    |    |    |    |    |    |    |    |    |    |
|            | Phone...              |   |   |   |   |   |   |   |   |   |    |    |    |    |    |    |    |    |    |    |    |    |    |    |    |    |    |    |    |    |    |    |

The following table describes the components of the User Information data block.

**Table 4-85** *User Information Data Block Fields*

| Field                         | Data Type | Description   |
|-------------------------------|-----------|---|
| User Information Block Type   | uint32    | Initiates a User Information data block. This value is 75 for version 4.7 - 4.10.x and a value of 120 for 5.0+.   |
| User Information Block Length | uint32    | Total number of bytes in the User Information data block, including eight bytes for the user information block type and length fields plus the number of bytes in the user information data that follows. |
| User ID                       | uint32    | Identification number of the user.  |
| String Block Type             | uint32    | Initiates a String data block containing the username for the user. This value is always 0.   |
| String Block Length           | uint32    | Number of bytes in the username String data block, including eight bytes for the block type and length fields plus the number of bytes in the username.   |
| Username                      | string    | The username for the user.  |
| Protocol                      | uint32    | The protocol for the packet containing the user information.  |
| String Block Type             | uint32    | Initiates a String data block containing the first name of the user. This value is always 0.  |
| String Block Length           | uint32    | Number of bytes in the first name String data block, including eight bytes for the block type and length fields plus the number of bytes in the first name.   |
| First Name                    | string    | The first name for the user.  |
| String Block Type             | uint32    | Initiates a String data block containing the last name for the user. This value is always 0.  |
| String Block Length           | uint32    | Number of bytes in the user last name String data block, including eight bytes for the block type and length fields, plus the number of bytes in the last name.   |
| Last Name                     | string    | The last name for the user.   |
| String Block Type             | uint32    | Initiates a String data block containing the email address for the user. This value is always 0.  |
| String Block Length           | uint32    | Number of bytes in the email address String data block, including eight bytes for the block type and length fields, plus the number of bytes in the email address.  |
| Email                         | string    | The email address for the user.   |
| String Block Type             | uint32    | Initiates a String data block containing the department for the user. This value is always 0.   |
| String Block Length           | uint32    | Number of bytes in the department String data block, including eight bytes for the block type and length fields, plus the number of bytes in the department.  |
| Department                    | string    | The department for the user.  |
| String Block Type             | uint32    | Initiates a String data block containing the phone number for the user. This value is always 0.   |

Table 4-85 User Information Data Block Fields (continued)

| Field               | Data Type | Description  |
|---------------------|-----------|--|
| String Block Length | uint32    | Number of bytes in the phone number String data block, including eight bytes for the block type and length fields, plus the number of bytes in the phone number. |
| Phone               | string    | The phone number for the user.   |

## User Login Information Data Block 5.1+

The User Login Information data block is used in User Information Update messages and conveys changes in login information for a detected user. For more information, see [User Information Update Message Block, page 4-55](#).

The User Login Information data block has a block type of 73 for version 4.7 - 4.10.x, a block type of 121 in the series 1 group of blocks for version 5.0 - 5.0.2, and a block type of 127 in the series 1 group of blocks for version 5.1+.

The graphic below shows the format of the User Login Information data block:

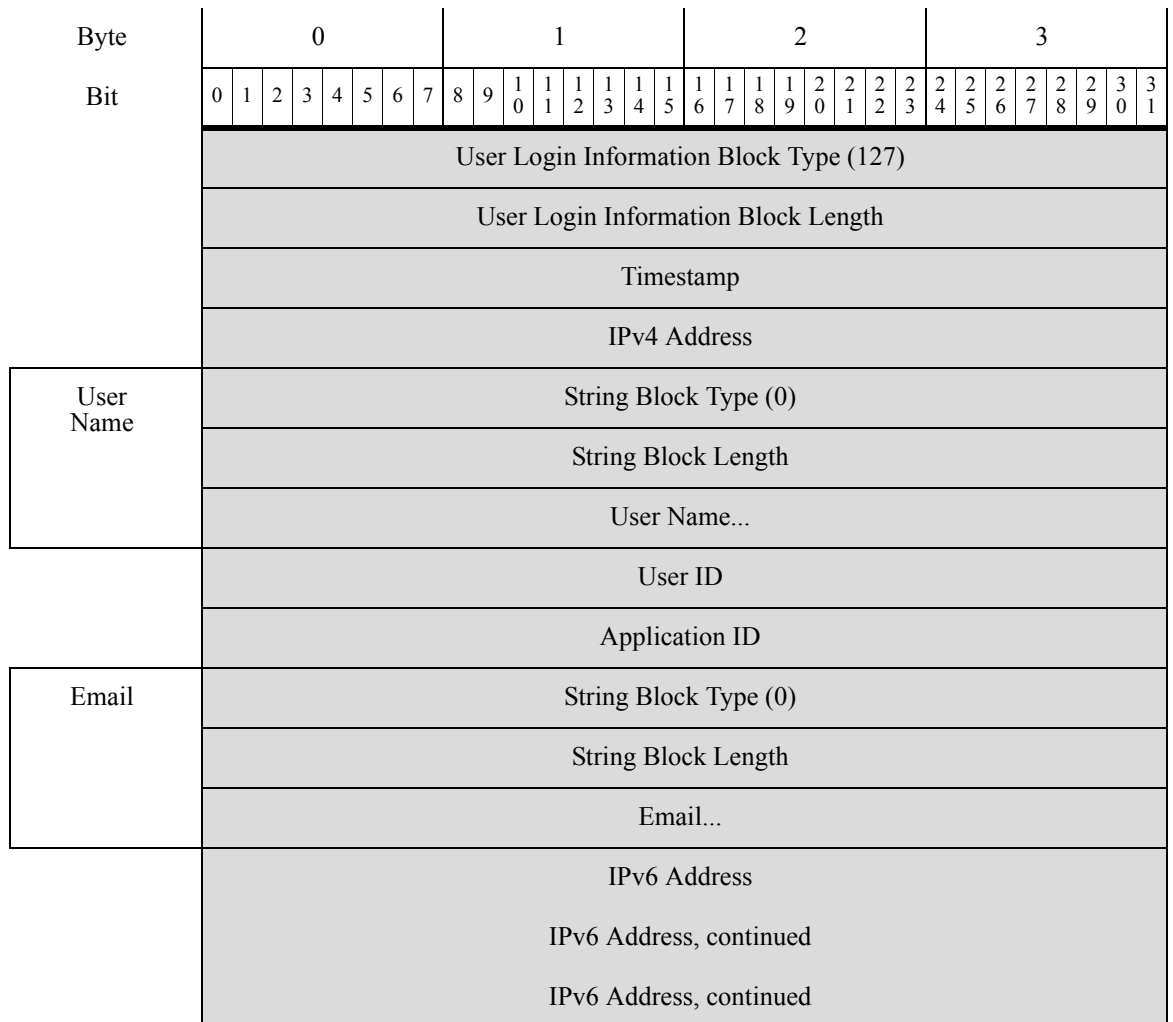

|             |                              |   |   |   |   |   |   |   |                       |   |    |    |    |    |    |    |    |    |    |    |    |    |    |    |    |    |    |    |    |    |    |    |
|-------------|------------------------------|---|---|---|---|---|---|---|-----------------------|---|----|----|----|----|----|----|----|----|----|----|----|----|----|----|----|----|----|----|----|----|----|----|
| Byte        | 0                            |   |   |   |   |   |   |   | 1                     |   |    |    |    |    |    |    | 2  |    |    |    |    |    |    |    | 3  |    |    |    |    |    |    |    |
| Bit         | 0                            | 1 | 2 | 3 | 4 | 5 | 6 | 7 | 8                     | 9 | 10 | 11 | 12 | 13 | 14 | 15 | 16 | 17 | 18 | 19 | 20 | 21 | 22 | 23 | 24 | 25 | 26 | 27 | 28 | 29 | 30 | 31 |
|             | IPv6 Address, continued      |   |   |   |   |   |   |   |                       |   |    |    |    |    |    |    |    |    |    |    |    |    |    |    |    |    |    |    |    |    |    |    |
| Reported By | Login Type                   |   |   |   |   |   |   |   | String Block Type (0) |   |    |    |    |    |    |    |    |    |    |    |    |    |    |    |    |    |    |    |    |    |    |    |
|             | String Block Type (0), cont. |   |   |   |   |   |   |   | String Block Length   |   |    |    |    |    |    |    |    |    |    |    |    |    |    |    |    |    |    |    |    |    |    |    |
|             | String Block Length          |   |   |   |   |   |   |   | Reported By...        |   |    |    |    |    |    |    |    |    |    |    |    |    |    |    |    |    |    |    |    |    |    |    |

The following table describes the components of the User Login Information data block.

**Table 4-86** User Login Information Data Block Fields

| Field                               | Data Type | Description  |
|-------------------------------------|-----------|--|
| User Login Information Block Type   | uint32    | Initiates a User Login Information data block. This value is 127 for version 5.1+.   |
| User Login Information Block Length | uint32    | Total number of bytes in the User Login Information data block, including eight bytes for the user login information block type and length fields, plus the number of bytes in the user login information data that follows. |
| Timestamp                           | uint32    | Timestamp of the event.  |
| IPv4 Address                        | uint32    | This field is reserved but no longer populated. The IPv4 address is stored in the IPv6 Address field. See <a href="#">IP Addresses, page 1-5</a> for more information.   |
| String Block Type                   | uint32    | Initiates a String data block containing the username for the user. This value is always 0.  |
| String Block Length                 | uint32    | Number of bytes in the username String data block, including eight bytes for the block type and length fields, plus the number of bytes in the username.   |
| Username                            | string    | The user name for the user.  |
| User ID                             | uint32    | Identification number of the user.   |
| Application ID                      | uint32    | The application ID for the application protocol used in the connection that the login information was derived from.  |
| String Block Type                   | uint32    | Initiates a String data block containing the email address for the user. This value is always 0.   |
| String Block Length                 | uint32    | Number of bytes in the email address String data block, including eight bytes for the block type and length fields, plus the number of bytes in the email address.   |
| Email                               | string    | The email address for the user.  |
| IPv6 Address                        | uint8[16] | IPv6 address from the host where the user was detected logging in, in IP address octets.   |



Table 4-86 User Login Information Data Block Fields (continued)

| Field               | Data Type | Description  |
|---------------------|-----------|--|
| Login Type          | uint8     | The type of user login detected.   |
| String Block Type   | uint32    | Initiates a String data block containing the Reported By value. This value is always 0.  |
| String Block Length | uint32    | Number of bytes in the Reported By String data block, including eight bytes for the block type and length fields, plus the number of bytes in the Reported By field. |
| Reported By         | string    | The name of the Active Directory server reporting a login.   |

## Discovery and Connection Event Series 2 Data Blocks

In the following table, the Data Block Status field indicates whether the block is current (the latest version) or legacy (used in an older version and can still be requested through eStreamer).

Table 4-87 Discovery and Connection Event Series 2 Block Types

| Type | Content                        | Data Block Status | Description  |
|------|--------------------------------|-------------------|--|
| 15   | Access Control Rule            | Current           | Used by access control rule metadata messages to map policy UUID and rule ID values to a descriptive string. See <a href="#">Access Control Rule Data Block</a> , page 4-173.          |
| 21   | Access Control Rule Reason     | Current           | Used by access control rule metadata messages to map access control rule reasons to a descriptive string. See <a href="#">Access Control Rule Reason Data Block 5.1+</a> , page 4-174. |
| 22   | Security Intelligence Category | Current           | Used to store Security Intelligence information. See <a href="#">Security Intelligence Category Data Block 5.1+</a> , page 4-175.  |

## Access Control Rule Data Block

The eStreamer service uses the Access Control Rule data block in access control rule metadata messages to map policy UUID and rule ID combinations to a descriptive string. The Access Control Rule data block has a block type of 15 in the series 2 group of blocks.

The following graphic shows the structure of the Access Control Rule data block.

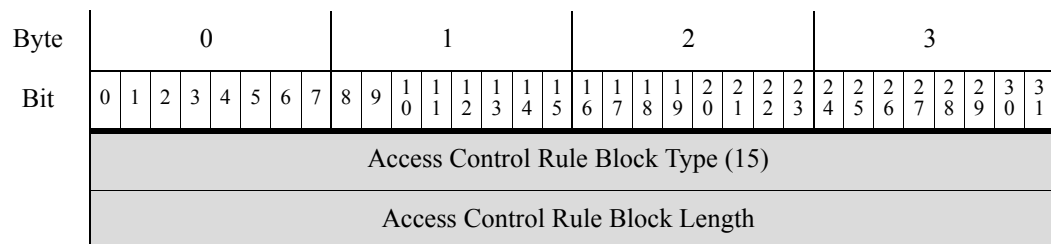

| Byte                                | 0 |   |   |   |   |   |   |   | 1 |   |    |    |    |    |    |    | 2  |    |    |    |    |    |    |    | 3  |    |    |    |    |    |    |    |
|-------------------------------------|---|---|---|---|---|---|---|---|---|---|----|----|----|----|----|----|----|----|----|----|----|----|----|----|----|----|----|----|----|----|----|----|
| Bit                                 | 0 | 1 | 2 | 3 | 4 | 5 | 6 | 7 | 8 | 9 | 10 | 11 | 12 | 13 | 14 | 15 | 16 | 17 | 18 | 19 | 20 | 21 | 22 | 23 | 24 | 25 | 26 | 27 | 28 | 29 | 30 | 31 |
| Access Control Rule UUID            |   |   |   |   |   |   |   |   |   |   |    |    |    |    |    |    |    |    |    |    |    |    |    |    |    |    |    |    |    |    |    |    |
| Access Control Rule UUID, continued |   |   |   |   |   |   |   |   |   |   |    |    |    |    |    |    |    |    |    |    |    |    |    |    |    |    |    |    |    |    |    |    |
| Access Control Rule UUID, continued |   |   |   |   |   |   |   |   |   |   |    |    |    |    |    |    |    |    |    |    |    |    |    |    |    |    |    |    |    |    |    |    |
| Access Control Rule UUID, continued |   |   |   |   |   |   |   |   |   |   |    |    |    |    |    |    |    |    |    |    |    |    |    |    |    |    |    |    |    |    |    |    |
| Access Control Rule ID              |   |   |   |   |   |   |   |   |   |   |    |    |    |    |    |    |    |    |    |    |    |    |    |    |    |    |    |    |    |    |    |    |
| String Block Type (0)               |   |   |   |   |   |   |   |   |   |   |    |    |    |    |    |    |    |    |    |    |    |    |    |    |    |    |    |    |    |    |    |    |
| String Block Length                 |   |   |   |   |   |   |   |   |   |   |    |    |    |    |    |    |    |    |    |    |    |    |    |    |    |    |    |    |    |    |    |    |
| Name...                             |   |   |   |   |   |   |   |   |   |   |    |    |    |    |    |    |    |    |    |    |    |    |    |    |    |    |    |    |    |    |    |    |

The following table describes the fields in the Access Control Rule data block.

**Table 4-88** Access Control Rule Data Block Fields

| Field                            | Data Type | Description  |
|----------------------------------|-----------|--|
| Access Control Rule Block Type   | uint32    | Initiates an Access Control Rule block. This value is always 15.   |
| Access Control Rule Block Length | uint32    | Total number of bytes in the Access Control Rule block, including eight bytes for the Access Control Rule block type and length fields, plus the number of bytes of data that follows. |
| Access Control Rule UUID         | uint8[16] | The unique identifier for the access control rule.   |
| Access Control Rule ID           | uint32    | The internal Cisco identifier for the access control rule.   |
| String Block Type                | uint32    | Initiates a String data block containing the descriptive name associated with the access control rule UUID and access control rule ID. This value is always 0.                         |
| String Block Length              | uint32    | The number of bytes included in the name String data block, including eight bytes for the block type and header fields plus the number of bytes in the Name field.                     |
| Name                             | string    | The descriptive name.  |

## Access Control Rule Reason Data Block 5.1+

The eStreamer service uses the Access Control Rule Reason data block in Access Control Rule Reason metadata messages to map Access Control reasons to a descriptive string. The Access Control Rule Reason data block has a block type of 21 in the series 2 group of blocks.

The following graphic shows the structure of the Access Control Rule Reason data block.:

|             |  |   |   |   |   |   |   |   |   |   |    |    |    |    |    |    |                       |    |    |    |    |    |    |    |    |    |    |    |    |    |    |    |
|-------------|--|---|---|---|---|---|---|---|---|---|----|----|----|----|----|----|-----------------------|----|----|----|----|----|----|----|----|----|----|----|----|----|----|----|
| Byte        | 0  |   |   |   |   |   |   |   | 1 |   |    |    |    |    |    |    | 2                     |    |    |    |    |    |    |    | 3  |    |    |    |    |    |    |    |
| Bit         | 0  | 1 | 2 | 3 | 4 | 5 | 6 | 7 | 8 | 9 | 10 | 11 | 12 | 13 | 14 | 15 | 16                    | 17 | 18 | 19 | 20 | 21 | 22 | 23 | 24 | 25 | 26 | 27 | 28 | 29 | 30 | 31 |
|             | Access Control Rule Reason Block Type (21) |   |   |   |   |   |   |   |   |   |    |    |    |    |    |    |                       |    |    |    |    |    |    |    |    |    |    |    |    |    |    |    |
|             | Access Control Rule Block Length           |   |   |   |   |   |   |   |   |   |    |    |    |    |    |    |                       |    |    |    |    |    |    |    |    |    |    |    |    |    |    |    |
| Description | Access Control Rule Reason                 |   |   |   |   |   |   |   |   |   |    |    |    |    |    |    | String Block Type (0) |    |    |    |    |    |    |    |    |    |    |    |    |    |    |    |
|             | String Block Type (0), cont.               |   |   |   |   |   |   |   |   |   |    |    |    |    |    |    | String Block Length   |    |    |    |    |    |    |    |    |    |    |    |    |    |    |    |
|             | String Block Length, cont.                 |   |   |   |   |   |   |   |   |   |    |    |    |    |    |    | Description...        |    |    |    |    |    |    |    |    |    |    |    |    |    |    |    |

The following table describes the fields in the Access Control Rule Reason data block.

**Table 4-89** Access Control Rule Reason Data Block Fields

| Field                                   | Data Type | Description  |
|---|-----------|--|
| Access Control Rule Reason Block Type   | uint32    | Initiates an Access Control Rule Reason block. This value is always 21.  |
| Access Control Rule Reason Block Length | uint32    | Total number of bytes in the Access Control Rule Reason block, including eight bytes for the Access Control Rule Reason block type and length fields, plus the number of bytes of data that follows. |
| Access Control Rule Reason              | uint16    | The reason the Access Control rule logged the connection.  |
| String Block Type                       | uint32    | Initiates a String data block containing the descriptive name associated with the access control rule reason. This value is always 0.  |
| String Block Length                     | uint32    | The number of bytes included in the name String data block, including eight bytes for the block type and header fields plus the number of bytes in the Description field.                            |
| Description                             | string    | Description of the Access Control rule reason.   |

## Security Intelligence Category Data Block 5.1+

The eStreamer service uses the Security Intelligence Category data block in access control rule metadata messages to stream Security Intelligence information. The Security Intelligence Category data block has a block type of 22 in the series 2 group of blocks.

The following graphic shows the structure of the Security Intelligence Category data block:

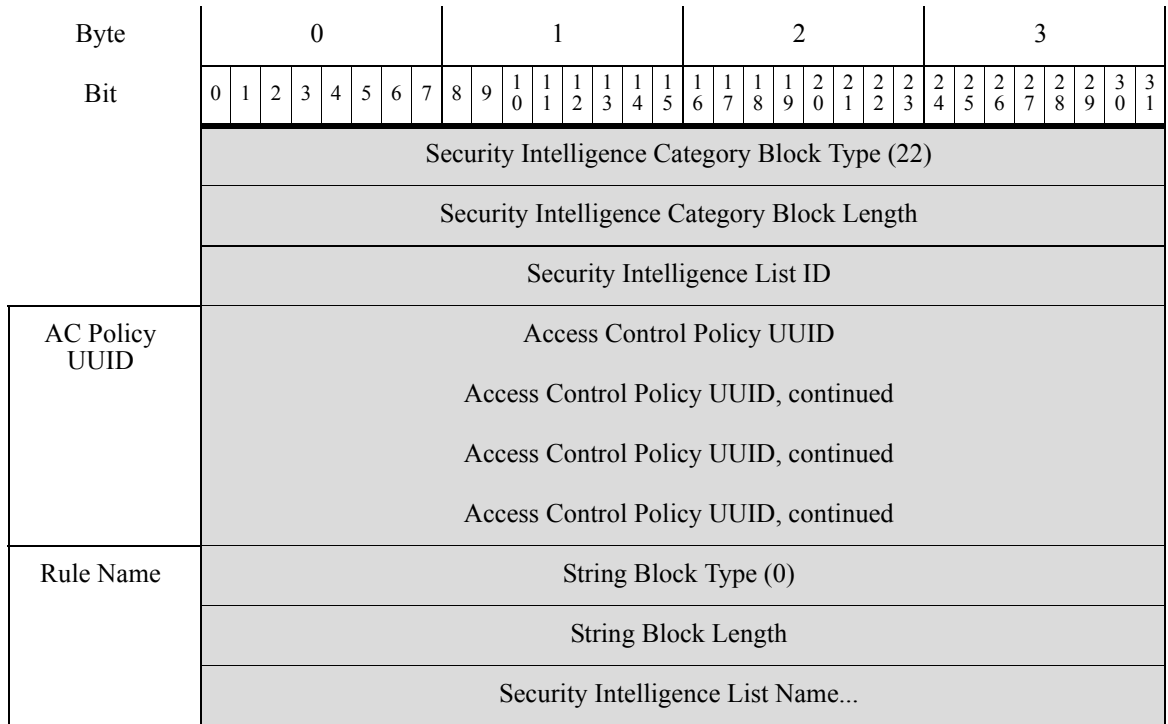

The following table describes the fields in the Security Intelligence Category data block.

**Table 4-90 Security Intelligence Category Data Block fields**

| Field                                       | Data Type | Description  |
|---|-----------|--|
| Security Intelligence Category Block Type   | uint32    | Initiates an Security Intelligence Category data block. This value is always 22.   |
| Security Intelligence Category Block Length | uint32    | Total number of bytes in the Security Intelligence Category block, including eight bytes for the Security Intelligence Category block type and length fields, plus the number of bytes of data that follows. |
| Security Intelligence List ID               | uint32    | The ID of the IP blacklist or whitelist triggered by the connection.   |
| Access Control Policy UUID                  | uint8[16] | The UUID of the access control policy configured for Security Intelligence.  |
| String Block Type                           | uint32    | Initiates a String data block containing the descriptive name associated with the access control rule reason. This value is always 0.  |
| String Block Length                         | uint32    | The number of bytes included in the name String data block, including eight bytes for the block type and header fields plus the number of bytes in the Security Intelligence List Name field.                |
| Security Intelligence List Name             | string    | The name of the Security Intelligence category IP blacklist or whitelist triggered by the connection.  |



## Understanding Host Data Structures

---

This chapter describes the format of the Full Host Profile data block that conveys a set of data describing a single host. The eStreamer server generates and sends these blocks on request for host data. For information about the client request procedure, the message structure, and the delivery method, see [Host Data and Multiple Host Data Message Format, page 2-29](#).

eStreamer uses the series 1 data block structure to package these Full Host profile blocks. For the general structure of series 1 blocks, see [Series 1 Data Block Header, page 4-55](#). The Full Host Profile data block contains a number of encapsulated blocks which are individually described in the subsections where they are defined in [Understanding Discovery & Connection Data Structures, page 4-1](#).

See the following sections for more information about current and legacy Full Host Profile data blocks:

- [Full Host Profile Data Block 5.3+, page 5-1](#) describes the current Full Host Profile data block structure.
- [Full Host Profile Data Block 5.0 - 5.0.2, page B-131](#) describes the legacy Full Host Profile data block structure for versions 5.0 - 5.0.2.

### Full Host Profile Data Block 5.3+

The Full Host Profile data block for version 5.3+ contains a full set of data describing one host. It has the format shown in the graphic below and explained in the following table. Note that, except for List data blocks, the graphic does not show the fields of the encapsulated data blocks. These encapsulated data blocks are described separately in [Understanding Discovery & Connection Data Structures, page 4-1](#). The Full Host Profile data block a block type value of 149. It supersedes the prior version, which has a block type of 140.



**Note**

---

An asterisk (\*) next to a block name in the following diagram indicates that multiple instances of the data block may occur.

---

The following diagram shows the format of the Full Host Profile data block for 5.3+:

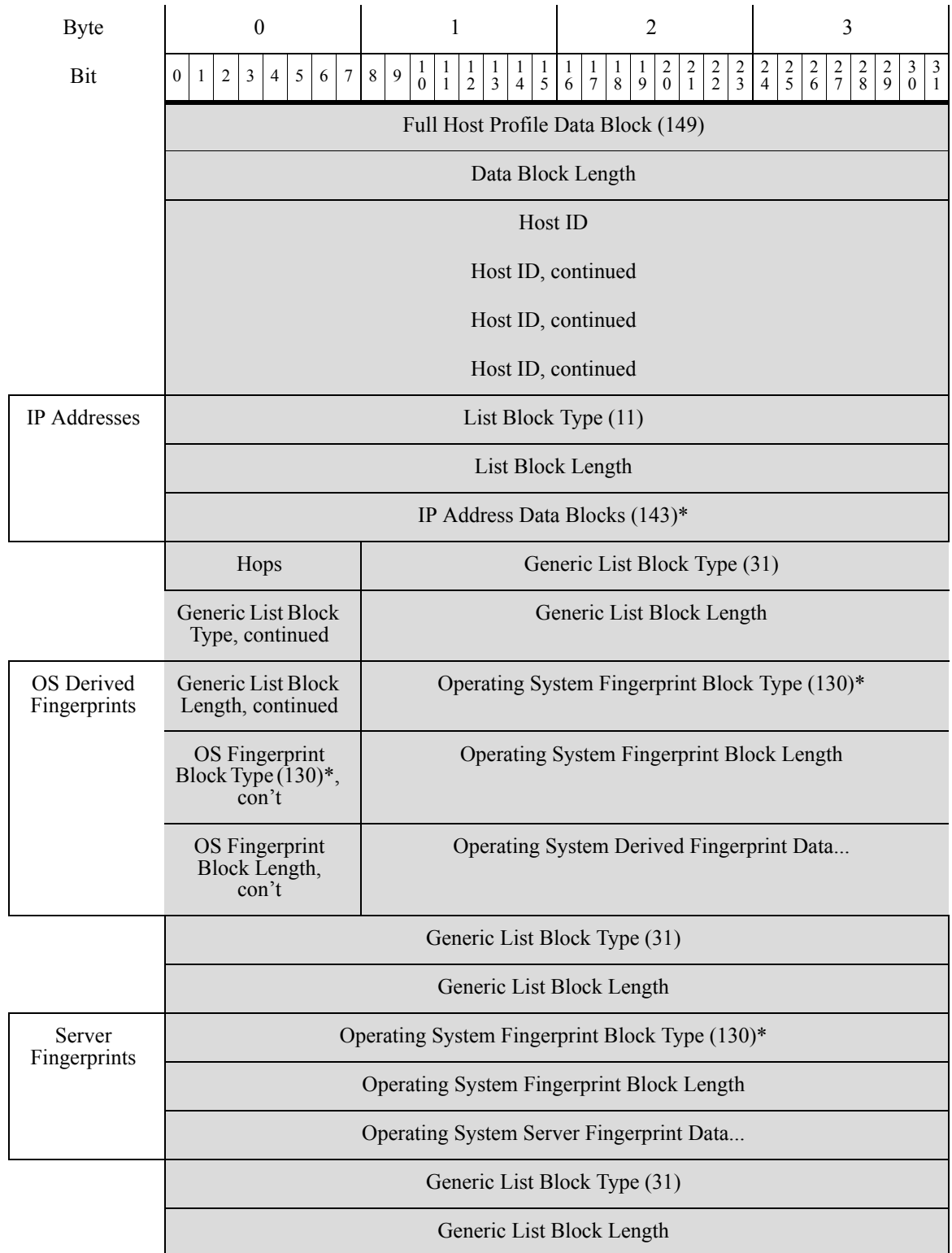

| Byte                      | 0  |   |   |   |   |   |   |   | 1 |   |    |    |    |    |    |    | 2  |    |    |    |    |    |    |    | 3  |    |    |    |    |    |    |    |
|---------------------------|--|---|---|---|---|---|---|---|---|---|----|----|----|----|----|----|----|----|----|----|----|----|----|----|----|----|----|----|----|----|----|----|
|                           | 0  | 1 | 2 | 3 | 4 | 5 | 6 | 7 | 8 | 9 | 10 | 11 | 12 | 13 | 14 | 15 | 16 | 17 | 18 | 19 | 20 | 21 | 22 | 23 | 24 | 25 | 26 | 27 | 28 | 29 | 30 | 31 |
| Client Fingerprints       | Operating System Fingerprint Block Type (130)* |   |   |   |   |   |   |   |   |   |    |    |    |    |    |    |    |    |    |    |    |    |    |    |    |    |    |    |    |    |    |    |
|                           | Operating System Fingerprint Block Length      |   |   |   |   |   |   |   |   |   |    |    |    |    |    |    |    |    |    |    |    |    |    |    |    |    |    |    |    |    |    |    |
|                           | Operating System Client Fingerprint Data...    |   |   |   |   |   |   |   |   |   |    |    |    |    |    |    |    |    |    |    |    |    |    |    |    |    |    |    |    |    |    |    |
|                           | Generic List Block Type (31)                   |   |   |   |   |   |   |   |   |   |    |    |    |    |    |    |    |    |    |    |    |    |    |    |    |    |    |    |    |    |    |    |
|                           | Generic List Block Length                      |   |   |   |   |   |   |   |   |   |    |    |    |    |    |    |    |    |    |    |    |    |    |    |    |    |    |    |    |    |    |    |
| VDB Native Fingerprints 1 | Operating System Fingerprint Block Type (130)* |   |   |   |   |   |   |   |   |   |    |    |    |    |    |    |    |    |    |    |    |    |    |    |    |    |    |    |    |    |    |    |
|                           | Operating System Fingerprint Block Length      |   |   |   |   |   |   |   |   |   |    |    |    |    |    |    |    |    |    |    |    |    |    |    |    |    |    |    |    |    |    |    |
|                           | Operating System VDB Fingerprint Data...       |   |   |   |   |   |   |   |   |   |    |    |    |    |    |    |    |    |    |    |    |    |    |    |    |    |    |    |    |    |    |    |
|                           | Generic List Block Type (31)                   |   |   |   |   |   |   |   |   |   |    |    |    |    |    |    |    |    |    |    |    |    |    |    |    |    |    |    |    |    |    |    |
|                           | Generic List Block Length                      |   |   |   |   |   |   |   |   |   |    |    |    |    |    |    |    |    |    |    |    |    |    |    |    |    |    |    |    |    |    |    |
| VDB Native Fingerprints 2 | Operating System Fingerprint Block Type (130)* |   |   |   |   |   |   |   |   |   |    |    |    |    |    |    |    |    |    |    |    |    |    |    |    |    |    |    |    |    |    |    |
|                           | Operating System Fingerprint Block Length      |   |   |   |   |   |   |   |   |   |    |    |    |    |    |    |    |    |    |    |    |    |    |    |    |    |    |    |    |    |    |    |
|                           | Operating System VDB Fingerprint Data...       |   |   |   |   |   |   |   |   |   |    |    |    |    |    |    |    |    |    |    |    |    |    |    |    |    |    |    |    |    |    |    |
|                           | Generic List Block Type (31)                   |   |   |   |   |   |   |   |   |   |    |    |    |    |    |    |    |    |    |    |    |    |    |    |    |    |    |    |    |    |    |    |
|                           | Generic List Block Length                      |   |   |   |   |   |   |   |   |   |    |    |    |    |    |    |    |    |    |    |    |    |    |    |    |    |    |    |    |    |    |    |
| User Fingerprints         | Operating System Fingerprint Block Type (130)* |   |   |   |   |   |   |   |   |   |    |    |    |    |    |    |    |    |    |    |    |    |    |    |    |    |    |    |    |    |    |    |
|                           | Operating System Fingerprint Block Length      |   |   |   |   |   |   |   |   |   |    |    |    |    |    |    |    |    |    |    |    |    |    |    |    |    |    |    |    |    |    |    |
|                           | Operating System User Fingerprint Data...      |   |   |   |   |   |   |   |   |   |    |    |    |    |    |    |    |    |    |    |    |    |    |    |    |    |    |    |    |    |    |    |
|                           | Generic List Block Type (31)                   |   |   |   |   |   |   |   |   |   |    |    |    |    |    |    |    |    |    |    |    |    |    |    |    |    |    |    |    |    |    |    |
|                           | Generic List Block Length                      |   |   |   |   |   |   |   |   |   |    |    |    |    |    |    |    |    |    |    |    |    |    |    |    |    |    |    |    |    |    |    |
| Scan Fingerprints         | Operating System Fingerprint Block Type (130)* |   |   |   |   |   |   |   |   |   |    |    |    |    |    |    |    |    |    |    |    |    |    |    |    |    |    |    |    |    |    |    |
|                           | Operating System Fingerprint Block Length      |   |   |   |   |   |   |   |   |   |    |    |    |    |    |    |    |    |    |    |    |    |    |    |    |    |    |    |    |    |    |    |
|                           | Operating System Scan Fingerprint Data...      |   |   |   |   |   |   |   |   |   |    |    |    |    |    |    |    |    |    |    |    |    |    |    |    |    |    |    |    |    |    |    |
|                           | Generic List Block Type (31)                   |   |   |   |   |   |   |   |   |   |    |    |    |    |    |    |    |    |    |    |    |    |    |    |    |    |    |    |    |    |    |    |
|                           | Generic List Block Length                      |   |   |   |   |   |   |   |   |   |    |    |    |    |    |    |    |    |    |    |    |    |    |    |    |    |    |    |    |    |    |    |

| Byte                     | 0  |   |   |   |   |   |   |   | 1 |   |    |    |    |    |    |    | 2  |    |    |    |    |    |    |    | 3  |    |    |    |    |    |    |    |
|--------------------------|--|---|---|---|---|---|---|---|---|---|----|----|----|----|----|----|----|----|----|----|----|----|----|----|----|----|----|----|----|----|----|----|
|                          | 0  | 1 | 2 | 3 | 4 | 5 | 6 | 7 | 8 | 9 | 10 | 11 | 12 | 13 | 14 | 15 | 16 | 17 | 18 | 19 | 20 | 21 | 22 | 23 | 24 | 25 | 26 | 27 | 28 | 29 | 30 | 31 |
| Application Fingerprints | Operating System Fingerprint Block Type (130)*   |   |   |   |   |   |   |   |   |   |    |    |    |    |    |    |    |    |    |    |    |    |    |    |    |    |    |    |    |    |    |    |
|                          | Operating System Fingerprint Block Length        |   |   |   |   |   |   |   |   |   |    |    |    |    |    |    |    |    |    |    |    |    |    |    |    |    |    |    |    |    |    |    |
|                          | Operating System Application Fingerprint Data... |   |   |   |   |   |   |   |   |   |    |    |    |    |    |    |    |    |    |    |    |    |    |    |    |    |    |    |    |    |    |    |
|                          | Generic List Block Type (31)                     |   |   |   |   |   |   |   |   |   |    |    |    |    |    |    |    |    |    |    |    |    |    |    |    |    |    |    |    |    |    |    |
|                          | Generic List Block Length                        |   |   |   |   |   |   |   |   |   |    |    |    |    |    |    |    |    |    |    |    |    |    |    |    |    |    |    |    |    |    |    |
| Conflict Fingerprints    | Operating System Fingerprint Block Type (130)*   |   |   |   |   |   |   |   |   |   |    |    |    |    |    |    |    |    |    |    |    |    |    |    |    |    |    |    |    |    |    |    |
|                          | Operating System Fingerprint Block Length        |   |   |   |   |   |   |   |   |   |    |    |    |    |    |    |    |    |    |    |    |    |    |    |    |    |    |    |    |    |    |    |
|                          | Operating System Conflict Fingerprint Data...    |   |   |   |   |   |   |   |   |   |    |    |    |    |    |    |    |    |    |    |    |    |    |    |    |    |    |    |    |    |    |    |
|                          | Generic List Block Type (31)                     |   |   |   |   |   |   |   |   |   |    |    |    |    |    |    |    |    |    |    |    |    |    |    |    |    |    |    |    |    |    |    |
|                          | Generic List Block Length                        |   |   |   |   |   |   |   |   |   |    |    |    |    |    |    |    |    |    |    |    |    |    |    |    |    |    |    |    |    |    |    |
| Mobile Fingerprints      | Operating System Fingerprint Block Type (130)*   |   |   |   |   |   |   |   |   |   |    |    |    |    |    |    |    |    |    |    |    |    |    |    |    |    |    |    |    |    |    |    |
|                          | Operating System Fingerprint Block Length        |   |   |   |   |   |   |   |   |   |    |    |    |    |    |    |    |    |    |    |    |    |    |    |    |    |    |    |    |    |    |    |
|                          | Operating System Mobile Fingerprint Data...      |   |   |   |   |   |   |   |   |   |    |    |    |    |    |    |    |    |    |    |    |    |    |    |    |    |    |    |    |    |    |    |
|                          | Generic List Block Type (31)                     |   |   |   |   |   |   |   |   |   |    |    |    |    |    |    |    |    |    |    |    |    |    |    |    |    |    |    |    |    |    |    |
|                          | Generic List Block Length                        |   |   |   |   |   |   |   |   |   |    |    |    |    |    |    |    |    |    |    |    |    |    |    |    |    |    |    |    |    |    |    |
| IPv6 Server Fingerprints | Operating System Fingerprint Block Type (130)*   |   |   |   |   |   |   |   |   |   |    |    |    |    |    |    |    |    |    |    |    |    |    |    |    |    |    |    |    |    |    |    |
|                          | Operating System Fingerprint Block Length        |   |   |   |   |   |   |   |   |   |    |    |    |    |    |    |    |    |    |    |    |    |    |    |    |    |    |    |    |    |    |    |
|                          | Operating System IPv6 Server Fingerprint Data... |   |   |   |   |   |   |   |   |   |    |    |    |    |    |    |    |    |    |    |    |    |    |    |    |    |    |    |    |    |    |    |
|                          | Generic List Block Type (31)                     |   |   |   |   |   |   |   |   |   |    |    |    |    |    |    |    |    |    |    |    |    |    |    |    |    |    |    |    |    |    |    |
|                          | Generic List Block Length                        |   |   |   |   |   |   |   |   |   |    |    |    |    |    |    |    |    |    |    |    |    |    |    |    |    |    |    |    |    |    |    |
| IPv6 Client Fingerprints | Operating System Fingerprint Block Type (130)*   |   |   |   |   |   |   |   |   |   |    |    |    |    |    |    |    |    |    |    |    |    |    |    |    |    |    |    |    |    |    |    |
|                          | Operating System Fingerprint Block Length        |   |   |   |   |   |   |   |   |   |    |    |    |    |    |    |    |    |    |    |    |    |    |    |    |    |    |    |    |    |    |    |
|                          | Operating System IPv6 Client Fingerprint Data... |   |   |   |   |   |   |   |   |   |    |    |    |    |    |    |    |    |    |    |    |    |    |    |    |    |    |    |    |    |    |    |
|                          | Generic List Block Type (31)                     |   |   |   |   |   |   |   |   |   |    |    |    |    |    |    |    |    |    |    |    |    |    |    |    |    |    |    |    |    |    |    |
|                          | Generic List Block Length                        |   |   |   |   |   |   |   |   |   |    |    |    |    |    |    |    |    |    |    |    |    |    |    |    |    |    |    |    |    |    |    |



| Byte                    | 0   |   |   |   |   |   |   |   | 1 |   |    |    |    |    |    |         | 2  |    |    |    |    |    |    |    | 3  |    |    |    |    |    |    |    |
|-------------------------|---|---|---|---|---|---|---|---|---|---|----|----|----|----|----|---------|----|----|----|----|----|----|----|----|----|----|----|----|----|----|----|----|
|                         | 0   | 1 | 2 | 3 | 4 | 5 | 6 | 7 | 8 | 9 | 10 | 11 | 12 | 13 | 14 | 15      | 16 | 17 | 18 | 19 | 20 | 21 | 22 | 23 | 24 | 25 | 26 | 27 | 28 | 29 | 30 | 31 |
| Ipv6 DHCP Fingerprints  | Operating System Fingerprint Block Type (130)*  |   |   |   |   |   |   |   |   |   |    |    |    |    |    |         |    |    |    |    |    |    |    |    |    |    |    |    |    |    |    |    |
|                         | Operating System Fingerprint Block Length       |   |   |   |   |   |   |   |   |   |    |    |    |    |    |         |    |    |    |    |    |    |    |    |    |    |    |    |    |    |    |    |
|                         | Operating System IPv6 DHCP Fingerprint Data...  |   |   |   |   |   |   |   |   |   |    |    |    |    |    |         |    |    |    |    |    |    |    |    |    |    |    |    |    |    |    |    |
|                         | Generic List Block Type (31)                    |   |   |   |   |   |   |   |   |   |    |    |    |    |    |         |    |    |    |    |    |    |    |    |    |    |    |    |    |    |    |    |
|                         | Generic List Block Length                       |   |   |   |   |   |   |   |   |   |    |    |    |    |    |         |    |    |    |    |    |    |    |    |    |    |    |    |    |    |    |    |
| User Agent Fingerprints | Operating System Fingerprint Block Type (130)*  |   |   |   |   |   |   |   |   |   |    |    |    |    |    |         |    |    |    |    |    |    |    |    |    |    |    |    |    |    |    |    |
|                         | Operating System Fingerprint Block Length       |   |   |   |   |   |   |   |   |   |    |    |    |    |    |         |    |    |    |    |    |    |    |    |    |    |    |    |    |    |    |    |
|                         | Operating System User Agent Fingerprint Data... |   |   |   |   |   |   |   |   |   |    |    |    |    |    |         |    |    |    |    |    |    |    |    |    |    |    |    |    |    |    |    |
| (TCP) Full Server Data  | List Block Type (11)...                         |   |   |   |   |   |   |   |   |   |    |    |    |    |    |         |    |    |    |    |    |    |    |    |    |    |    |    |    |    |    |    |
|                         | List Block Length...                            |   |   |   |   |   |   |   |   |   |    |    |    |    |    |         |    |    |    |    |    |    |    |    |    |    |    |    |    |    |    |    |
|                         | (TCP) Full Server Data Blocks (104)*            |   |   |   |   |   |   |   |   |   |    |    |    |    |    |         |    |    |    |    |    |    |    |    |    |    |    |    |    |    |    |    |
| (UDP) Full Server Data  | List Block Type (11)                            |   |   |   |   |   |   |   |   |   |    |    |    |    |    |         |    |    |    |    |    |    |    |    |    |    |    |    |    |    |    |    |
|                         | List Block Length                               |   |   |   |   |   |   |   |   |   |    |    |    |    |    |         |    |    |    |    |    |    |    |    |    |    |    |    |    |    |    |    |
|                         | (UDP) Full Server Data Blocks (104)*            |   |   |   |   |   |   |   |   |   |    |    |    |    |    |         |    |    |    |    |    |    |    |    |    |    |    |    |    |    |    |    |
| Network Protocol Data   | List Block Type (11)                            |   |   |   |   |   |   |   |   |   |    |    |    |    |    |         |    |    |    |    |    |    |    |    |    |    |    |    |    |    |    |    |
|                         | List Block Length                               |   |   |   |   |   |   |   |   |   |    |    |    |    |    |         |    |    |    |    |    |    |    |    |    |    |    |    |    |    |    |    |
|                         | (Network) Protocol Data Blocks (4)*             |   |   |   |   |   |   |   |   |   |    |    |    |    |    |         |    |    |    |    |    |    |    |    |    |    |    |    |    |    |    |    |
| Transport Protocol Data | List Block Type (11)                            |   |   |   |   |   |   |   |   |   |    |    |    |    |    |         |    |    |    |    |    |    |    |    |    |    |    |    |    |    |    |    |
|                         | List Block Length                               |   |   |   |   |   |   |   |   |   |    |    |    |    |    |         |    |    |    |    |    |    |    |    |    |    |    |    |    |    |    |    |
|                         | (Transport) Protocol Data Blocks (4)*           |   |   |   |   |   |   |   |   |   |    |    |    |    |    |         |    |    |    |    |    |    |    |    |    |    |    |    |    |    |    |    |
| MAC Address Data        | List Block Type (11)                            |   |   |   |   |   |   |   |   |   |    |    |    |    |    |         |    |    |    |    |    |    |    |    |    |    |    |    |    |    |    |    |
|                         | List Block Length                               |   |   |   |   |   |   |   |   |   |    |    |    |    |    |         |    |    |    |    |    |    |    |    |    |    |    |    |    |    |    |    |
|                         | Host MAC Address Data Blocks (95)*              |   |   |   |   |   |   |   |   |   |    |    |    |    |    |         |    |    |    |    |    |    |    |    |    |    |    |    |    |    |    |    |
| Last Seen               |   |   |   |   |   |   |   |   |   |   |    |    |    |    |    |         |    |    |    |    |    |    |    |    |    |    |    |    |    |    |    |    |
| Host Type               |   |   |   |   |   |   |   |   |   |   |    |    |    |    |    |         |    |    |    |    |    |    |    |    |    |    |    |    |    |    |    |    |
| Business Criticality    |   |   |   |   |   |   |   |   |   |   |    |    |    |    |    | VLAN ID |    |    |    |    |    |    |    |    |    |    |    |    |    |    |    |    |

| Byte                    | 0  |   |   |   |   |   |   |   | 1             |   |    |    |    |    |    |    | 2   |    |    |    |    |    |    |    | 3  |    |    |    |    |    |    |    |
|-------------------------|--|---|---|---|---|---|---|---|---------------|---|----|----|----|----|----|----|---|----|----|----|----|----|----|----|----|----|----|----|----|----|----|----|
| Bit                     | 0  | 1 | 2 | 3 | 4 | 5 | 6 | 7 | 8             | 9 | 10 | 11 | 12 | 13 | 14 | 15 | 16  | 17 | 18 | 19 | 20 | 21 | 22 | 23 | 24 | 25 | 26 | 27 | 28 | 29 | 30 | 31 |
|                         | VLAN Type  |   |   |   |   |   |   |   | VLAN Priority |   |    |    |    |    |    |    | Generic List Block Type (31)                    |    |    |    |    |    |    |    |    |    |    |    |    |    |    |    |
| Host Client Data        | Generic List Block Type, continued   |   |   |   |   |   |   |   |               |   |    |    |    |    |    |    | Generic List Block Length                       |    |    |    |    |    |    |    |    |    |    |    |    |    |    |    |
|                         | Generic List Block Length, continued   |   |   |   |   |   |   |   |               |   |    |    |    |    |    |    | Full Host Client Application Data Blocks (112)* |    |    |    |    |    |    |    |    |    |    |    |    |    |    |    |
| NetBios Name            | String Block Type (0)  |   |   |   |   |   |   |   |               |   |    |    |    |    |    |    |   |    |    |    |    |    |    |    |    |    |    |    |    |    |    |    |
| Name                    | String Block Length  |   |   |   |   |   |   |   |               |   |    |    |    |    |    |    |   |    |    |    |    |    |    |    |    |    |    |    |    |    |    |    |
|                         | NetBIOS Name String...   |   |   |   |   |   |   |   |               |   |    |    |    |    |    |    |   |    |    |    |    |    |    |    |    |    |    |    |    |    |    |    |
| Notes Data              | String Block Type (0)  |   |   |   |   |   |   |   |               |   |    |    |    |    |    |    |   |    |    |    |    |    |    |    |    |    |    |    |    |    |    |    |
|                         | String Block Length  |   |   |   |   |   |   |   |               |   |    |    |    |    |    |    |   |    |    |    |    |    |    |    |    |    |    |    |    |    |    |    |
|                         | Notes String....   |   |   |   |   |   |   |   |               |   |    |    |    |    |    |    |   |    |    |    |    |    |    |    |    |    |    |    |    |    |    |    |
| (VDB) Host Vulns        | Generic List Block Type (31)   |   |   |   |   |   |   |   |               |   |    |    |    |    |    |    |   |    |    |    |    |    |    |    |    |    |    |    |    |    |    |    |
|                         | Generic List Block Length  |   |   |   |   |   |   |   |               |   |    |    |    |    |    |    |   |    |    |    |    |    |    |    |    |    |    |    |    |    |    |    |
|                         | (VDB) Host Vulnerability Data Blocks (85)*                                     |   |   |   |   |   |   |   |               |   |    |    |    |    |    |    |   |    |    |    |    |    |    |    |    |    |    |    |    |    |    |    |
| 3rd Pty/VDB) Host Vulns | Generic List Block Type (31)   |   |   |   |   |   |   |   |               |   |    |    |    |    |    |    |   |    |    |    |    |    |    |    |    |    |    |    |    |    |    |    |
|                         | Generic List Block Length  |   |   |   |   |   |   |   |               |   |    |    |    |    |    |    |   |    |    |    |    |    |    |    |    |    |    |    |    |    |    |    |
|                         | (Third Party/VDB) Host Vulnerability Data Blocks (85)*                         |   |   |   |   |   |   |   |               |   |    |    |    |    |    |    |   |    |    |    |    |    |    |    |    |    |    |    |    |    |    |    |
| 3rd Pty Scan Host Vulns | Generic List Block Type (31)   |   |   |   |   |   |   |   |               |   |    |    |    |    |    |    |   |    |    |    |    |    |    |    |    |    |    |    |    |    |    |    |
|                         | Generic List Block Length  |   |   |   |   |   |   |   |               |   |    |    |    |    |    |    |   |    |    |    |    |    |    |    |    |    |    |    |    |    |    |    |
|                         | (Third Party Scan) Host Vulnerability Data Blocks with Original Vuln IDs (85)* |   |   |   |   |   |   |   |               |   |    |    |    |    |    |    |   |    |    |    |    |    |    |    |    |    |    |    |    |    |    |    |
| Attribute Value Data    | List Block Type (11)   |   |   |   |   |   |   |   |               |   |    |    |    |    |    |    |   |    |    |    |    |    |    |    |    |    |    |    |    |    |    |    |
|                         | List Block Length  |   |   |   |   |   |   |   |               |   |    |    |    |    |    |    |   |    |    |    |    |    |    |    |    |    |    |    |    |    |    |    |
|                         | Attribute Value Data Blocks *  |   |   |   |   |   |   |   |               |   |    |    |    |    |    |    |   |    |    |    |    |    |    |    |    |    |    |    |    |    |    |    |
|                         | Mobile   |   |   |   |   |   |   |   | Jailbroken    |   |    |    |    |    |    |    | Generic List Block Type (31)                    |    |    |    |    |    |    |    |    |    |    |    |    |    |    |    |
| IOC State               | Generic List Block Type, continued   |   |   |   |   |   |   |   |               |   |    |    |    |    |    |    | Generic List Block Length                       |    |    |    |    |    |    |    |    |    |    |    |    |    |    |    |
|                         | Generic List Block Length, continued   |   |   |   |   |   |   |   |               |   |    |    |    |    |    |    | IOC State Data Blocks (150)*                    |    |    |    |    |    |    |    |    |    |    |    |    |    |    |    |

The following table describes the components of the Full Host Profile for 5.3+ record.

**Table 5-1 Full Host Profile Record 5.3+ Fields**

| Field   | Data Type | Description  |
|---|-----------|--|
| Host ID   | uint8[16] | Unique ID number of the host. This is a UUID.  |
| List Block Type   | uint32    | Initiates a List data block comprising IP address data blocks conveying TCP service data. This value is always 11.   |
| List Block Length   | uint32    | Number of bytes in the list. This number includes the eight bytes of the list block type and length fields, plus the length of all encapsulated IP address data blocks.  |
| IP Address  | variable  | IP addresses of the host and when each IP address was last seen. See <a href="#">Host IP Address Data Block, page 4-90</a> for a description of this data block.   |
| Hops  | uint8     | Number of network hops from the host to the device.  |
| Generic List Block Type   | uint32    | Initiates a Generic List data block comprising Operating System Fingerprint data blocks conveying fingerprint data derived from the existing fingerprints for the host. This value is always 31.   |
| Generic List Block Length                                       | uint32    | Number of bytes in the Generic List data block, including the list header and all encapsulated Operating System Fingerprint data blocks.   |
| Operating System Derived Fingerprint Data Blocks *              | variable  | Operating System Fingerprint data blocks containing information about the operating system on a host derived from the existing fingerprints for the host. See <a href="#">Operating System Fingerprint Data Block 5.1+, page 4-141</a> for a description of this data block. |
| Generic List Block Type   | uint32    | Initiates a Generic List data block comprising Operating System Fingerprint data blocks conveying fingerprint data identified using a server fingerprint. This value is always 31.   |
| Generic List Block Length                                       | uint32    | Number of bytes in the Generic List data block, including the list header and all encapsulated Operating System Fingerprint data blocks.   |
| Operating System Fingerprint (Server Fingerprint) Data Blocks * | variable  | Operating System Fingerprint data blocks containing information about the operating system on a host identified using a server fingerprint. See <a href="#">Operating System Fingerprint Data Block 5.1+, page 4-141</a> for a description of this data block.               |
| Generic List Block Type   | uint32    | Initiates a Generic List data block comprising Operating System Fingerprint data blocks conveying fingerprint data identified using a client fingerprint. This value is always 31.   |
| Generic List Block Length                                       | uint32    | Number of bytes in the Generic List data block, including the list header and all encapsulated Operating System Fingerprint data blocks.   |
| Operating System Fingerprint (Client Fingerprint) Data Blocks * | variable  | Operating System Fingerprint data blocks containing information about the operating system on a host identified using a client fingerprint. See <a href="#">Operating System Fingerprint Data Block 5.1+, page 4-141</a> for a description of this data block.               |

Table 5-1 Full Host Profile Record 5.3+ Fields (continued)

| Field  | Data Type | Description  |
|--|-----------|--|
| Generic List Block Type  | uint32    | Initiates a Generic List data block comprising Operating System Fingerprint data blocks conveying fingerprint data identified using a Cisco VDB fingerprint. This value is always 31.  |
| Generic List Block Length  | uint32    | Number of bytes in the Generic List data block, including the list header and all encapsulated Operating System Fingerprint data blocks.   |
| Operating System Fingerprint (VDB) Native Fingerprint 1) Data Blocks * | variable  | Operating System Fingerprint data blocks containing information about the operating system on a host identified using the fingerprints in the Cisco vulnerability database (VDB). See <a href="#">Operating System Fingerprint Data Block 5.1+, page 4-141</a> for a description of this data block. |
| Generic List Block Type  | uint32    | Initiates a Generic List data block comprising Operating System Fingerprint data blocks conveying fingerprint data identified using a Cisco VDB fingerprint. This value is always 31.  |
| Generic List Block Length  | uint32    | Number of bytes in the Generic List data block, including the list header and all encapsulated Operating System Fingerprint data blocks.   |
| Operating System Fingerprint (VDB) Native Fingerprint 2) Data Blocks * | variable  | Operating System Fingerprint data blocks containing information about the operating system on a host identified using the fingerprints in the Cisco vulnerability database (VDB). See <a href="#">Operating System Fingerprint Data Block 5.1+, page 4-141</a> for a description of this data block. |
| Generic List Block Type  | uint32    | Initiates a Generic List data block comprising Operating System Fingerprint data blocks conveying fingerprint data added by a user. This value is always 31.   |
| Generic List Block Length  | uint32    | Number of bytes in the Generic List data block, including the list header and all encapsulated Operating System Fingerprint data blocks.   |
| Operating System Fingerprint (User Fingerprint) Data Blocks *          | variable  | Operating System Fingerprint data blocks containing information about the operating system on a host added by a user. See <a href="#">Operating System Fingerprint Data Block 5.1+, page 4-141</a> for a description of this data block.   |
| Generic List Block Type  | uint32    | Initiates a Generic List data block comprising Operating System Fingerprint data blocks conveying fingerprint data added by a vulnerability scanner. This value is always 31.  |
| Generic List Block Length  | uint32    | Number of bytes in the Generic List data block, including the list header and all encapsulated Operating System Fingerprint data blocks.   |
| Operating System Fingerprint (Scan Fingerprint) Data Blocks *          | variable  | Operating System Fingerprint data blocks containing information about the operating system on a host added by a vulnerability scanner. See <a href="#">Operating System Fingerprint Data Block 5.1+, page 4-141</a> for a description of this data block.  |
| Generic List Block Type  | uint32    | Initiates a Generic List data block comprising Operating System Fingerprint data blocks conveying fingerprint data added by an application. This value is always 31.   |

Table 5-1 Full Host Profile Record 5.3+ Fields (continued)

| Field  | Data Type | Description  |
|--|-----------|--|
| Generic List Block Length  | uint32    | Number of bytes in the Generic List data block, including the list header and all encapsulated Operating System Fingerprint data blocks.   |
| Operating System Fingerprint (Application Fingerprint) Data Blocks * | variable  | Operating System Fingerprint data blocks containing information about the operating system on a host added by an application. See <a href="#">Operating System Fingerprint Data Block 5.1+</a> , page 4-141 for a description of this data block.                          |
| Generic List Block Type  | uint32    | Initiates a Generic List data block comprising Operating System Fingerprint data blocks conveying fingerprint data selected through fingerprint conflict resolution. This value is always 31.  |
| Generic List Block Length  | uint32    | Number of bytes in the Generic List data block, including the list header and all encapsulated Operating System Fingerprint data blocks.   |
| Operating System Fingerprint (Conflict Fingerprint) Data Blocks *    | variable  | Operating System Fingerprint data blocks containing information about the operating system on a host selected through fingerprint conflict resolution. See <a href="#">Operating System Fingerprint Data Block 5.1+</a> , page 4-141 for a description of this data block. |
| Generic List Block Type  | uint32    | Initiates a Generic List data block comprising Operating System Fingerprint data blocks conveying mobile device fingerprint data. This value is always 31.   |
| Generic List Block Length  | uint32    | Number of bytes in the Generic List data block, including the list header and all encapsulated Operating System Fingerprint data blocks.   |
| Operating System Fingerprint (Mobile) Data Blocks *                  | variable  | Operating System Fingerprint data blocks containing information about the operating system on a mobile device host. See <a href="#">Operating System Fingerprint Data Block 5.1+</a> , page 4-141 for a description of this data block.                                    |
| Generic List Block Type  | uint32    | Initiates a Generic List data block comprising Operating System Fingerprint data blocks conveying fingerprint data identified using an IPv6 server fingerprint. This value is always 31.   |
| Generic List Block Length  | uint32    | Number of bytes in the Generic List data block, including the list header and all encapsulated Operating System Fingerprint data blocks.   |
| Operating System Fingerprint (IPv6 Server Fingerprint) Data Blocks * | variable  | Operating System Fingerprint data blocks containing information about the operating system on a host identified using an IPv6 server fingerprint. See <a href="#">Operating System Fingerprint Data Block 5.1+</a> , page 4-141 for a description of this data block.      |
| Generic List Block Type  | uint32    | Initiates a Generic List data block comprising Operating System Fingerprint data blocks conveying fingerprint data identified using an IPv6 client fingerprint. This value is always 31.   |
| Generic List Block Length  | uint32    | Number of bytes in the Generic List data block, including the list header and all encapsulated Operating System Fingerprint data blocks.   |

Table 5-1 Full Host Profile Record 5.3+ Fields (continued)

| Field  | Data Type | Description   |
|--|-----------|---|
| Operating System Fingerprint (IPv6 Client Fingerprint) Data Blocks * | variable  | Operating System Fingerprint data blocks containing information about the operating system on a host identified using an IPv6 client fingerprint. See <a href="#">Operating System Fingerprint Data Block 5.1+</a> , page 4-141 for a description of this data block. |
| Generic List Block Type  | uint32    | Initiates a Generic List data block comprising Operating System Fingerprint data blocks conveying fingerprint data identified using an IPv6 DHCP fingerprint. This value is always 31.  |
| Generic List Block Length  | uint32    | Number of bytes in the Generic List data block, including the list header and all encapsulated Operating System Fingerprint data blocks.  |
| Operating System Fingerprint (IPv6 DHCP) Data Blocks *               | variable  | Operating System Fingerprint data blocks containing information about the operating system on a host identified using an IPv6 DHCP fingerprint. See <a href="#">Operating System Fingerprint Data Block 5.1+</a> , page 4-141 for a description of this data block.   |
| Generic List Block Type  | uint32    | Initiates a Generic List data block comprising Operating System Fingerprint data blocks conveying fingerprint data identified using a user agent fingerprint. This value is always 31.  |
| Generic List Block Length  | uint32    | Number of bytes in the Generic List data block, including the list header and all encapsulated Operating System Fingerprint data blocks.  |
| Operating System Fingerprint (User Agent) Data Blocks *              | variable  | Operating System Fingerprint data blocks containing information about the operating system on a host identified using a user agent fingerprint. See <a href="#">Operating System Fingerprint Data Block 5.1+</a> , page 4-141 for a description of this data block.   |
| List Block Type  | uint32    | Initiates a List data block comprising Full Server data blocks conveying TCP service data. This value is always 11.   |
| List Block Length  | uint32    | Number of bytes in the list. This number includes the eight bytes of the list block type and length fields, plus the length of all encapsulated Full Server data blocks.  |
| (TCP) Full Server Data Blocks *                                      | variable  | List of Full Server data blocks conveying data about the TCP services on the host. See <a href="#">Full Host Server Data Block 4.10.0+</a> , page 4-122 for a description of this data block.   |
| List Block Type  | uint32    | Initiates a List data block comprising Full Server data blocks conveying UDP service data. This value is always 11.   |
| List Block Length  | uint32    | Number of bytes in the list. This number includes the eight bytes of the list block type and length fields, plus the length of all encapsulated Full Server data blocks.  |
| (UDP) Full Server Data Blocks *                                      | variable  | List of Full Server data blocks conveying data about the UDP sub-servers on the host. See <a href="#">Full Host Server Data Block 4.10.0+</a> , page 4-122 for a description of this data block.  |
| List Block Type  | uint32    | Initiates a List data block comprising Protocol data blocks conveying network protocol data. This value is always 11.   |

Table 5-1 Full Host Profile Record 5.3+ Fields (continued)

| Field                              | Data Type | Description   |
|------------------------------------|-----------|---|
| List Block Length                  | uint32    | Number of bytes in the list. This number includes the eight bytes of the list block type and length fields, plus the length of all encapsulated Protocol data blocks.   |
| (Network) Protocol Data Blocks *   | variable  | List of Protocol data blocks conveying data about the network protocols on the host. See <a href="#">Protocol Data Block, page 4-68</a> for a description of this data block.   |
| List Block Type                    | uint32    | Initiates a List data block comprising Protocol data blocks conveying transport protocol data. This value is always 11.   |
| List Block Length                  | uint32    | Number of bytes in the list. This number includes the eight bytes of the list block type and length fields, plus the length of all encapsulated Protocol data blocks.   |
| (Transport) Protocol Data Blocks * | variable  | List of Protocol data blocks conveying data about the transport protocols on the host. See <a href="#">Protocol Data Block, page 4-68</a> for a description of this data block.   |
| List Block Type                    | uint32    | Initiates a List data block containing Host MAC Address data blocks. This value is always 11.   |
| List Block Length                  | uint32    | Number of bytes in the list, including the list header and all encapsulated Host MAC Address data blocks.   |
| Host MAC Address Data Blocks *     | variable  | List of Host MAC Address data blocks. See <a href="#">Host MAC Address 4.9+, page 4-108</a> for a description of this data block.   |
| Last Seen                          | uint32    | UNIX timestamp that represents the last time the system detected host activity.   |
| Host Type                          | uint32    | Indicates host type. Values include: <ul style="list-style-type: none"> <li>• 0 - host</li> <li>• 1 - router</li> <li>• 2 - bridge</li> <li>• 3 - NAT (network address translation device)</li> <li>• 4 - LB (load balancer)</li> </ul> |
| Business Criticality               | uint16    | Indicates criticality of host to business.  |
| VLAN ID                            | uint16    | VLAN identification number that indicates which VLAN the host is a member of.   |
| VLAN Type                          | uint8     | Type of packet encapsulated in the VLAN tag.  |
| VLAN Priority                      | uint8     | Priority value included in the VLAN tag.  |
| Generic List Block Type            | uint32    | Initiates a Generic List data block comprising Host Vulnerability data blocks conveying Client Application data. This value is always 31.   |
| Generic List Block Length          | uint32    | Number of bytes in the Generic List data block, including the list header and all encapsulated Client Application data blocks.  |

Table 5-1 Full Host Profile Record 5.3+ Fields (continued)

| Field   | Data Type | Description  |
|---|-----------|--|
| Full Host Client Application Data Blocks *          | variable  | List of Client Application data blocks. See <a href="#">Full Host Client Application Data Block 5.0+</a> , page 4-136 for a description of this data block.  |
| String Block Type                                   | uint32    | Initiates a String data block for the host NetBIOS name. This value is always 0.   |
| String Block Length                                 | uint32    | Number of bytes in the String data block, including eight bytes for the string block type and length fields, plus the number of bytes in the NetBIOS name string.  |
| NetBIOS Name  | string    | Host NetBIOS name string.  |
| String Block Type                                   | uint32    | Initiates a String data block for host notes. This value is always 0.  |
| String Block Length                                 | uint32    | Number of bytes in the notes String data block, including eight bytes for the string block type and length fields, plus the number of bytes in the notes string.   |
| Notes   | string    | Contains the contents of the Notes host attribute for the host.  |
| Generic List Block Type                             | uint32    | Initiates a Generic List data block comprising Host Vulnerability data blocks conveying VDB vulnerability data. This value is always 31.   |
| Generic List Block Length                           | uint32    | Number of bytes in the Generic List data block, including the list header and all encapsulated data blocks.  |
| (VDB) Host Vulnerability Data Blocks *              | variable  | List of Host Vulnerability data blocks for vulnerabilities identified in the Cisco vulnerability database (VDB). See <a href="#">Host Vulnerability Data Block 4.9.0+</a> , page 4-105 for a description of this data block.   |
| Generic List Block Type                             | uint32    | Initiates a Generic List data block comprising Host Vulnerability data blocks conveying third-party scan vulnerability data. This value is always 31.  |
| Generic List Block Length                           | uint32    | Number of bytes in the Generic List data block, including the list header and all encapsulated data blocks.  |
| (Third Party/VDB) Host Vulnerability Data Blocks *  | variable  | Host Vulnerability data blocks sourced from a third party scanner and containing information about host vulnerabilities cataloged in the Cisco vulnerability database (VDB). See <a href="#">Host Vulnerability Data Block 4.9.0+</a> , page 4-105 for a description of this data block.           |
| Generic List Block Type                             | uint32    | Initiates a Generic List data block comprising Host Vulnerability data blocks conveying third party scan vulnerability data. This value is always 31.  |
| Generic List Block Length                           | uint32    | Number of bytes in the Generic List data block, including the list header and all encapsulated data blocks.  |
| (Third Party Scan) Host Vulnerability Data Blocks * | variable  | Host Vulnerability data blocks sourced from a third party scanner. Note that the host vulnerability IDs for these data blocks are the third party scanner IDs, not Cisco-detected IDs. See <a href="#">Host Vulnerability Data Block 4.9.0+</a> , page 4-105 for a description of this data block. |
| List Block Type                                     | uint32    | Initiates a List data block comprising Attribute Value data blocks conveying attribute data. This value is always 11.  |



Table 5-1 Full Host Profile Record 5.3+ Fields (continued)

| Field                         | Data Type | Description   |
|-------------------------------|-----------|---|
| List Block Length             | uint32    | Number of bytes in the List data block, including the list header and all encapsulated data blocks.   |
| Attribute Value Data Blocks * | variable  | List of Attribute Value data blocks. See <a href="#">Attribute Value Data Block, page 4-75</a> for a description of the data blocks in this list. |
| Mobile                        | uint8     | A true-false flag indicating whether the operating system is running on a mobile device.  |
| Jailbroken                    | uint8     | A true-false flag indicating whether the mobile device operating system is jailbroken.  |
| Generic List Block Type       | uint32    | Initiates a Generic List data block comprising IOC State data blocks. This value is always 31.  |
| Generic List Block Length     | uint32    | Number of bytes in the Generic List data block, including the list header and all encapsulated IOC State data blocks.                             |
| IOC State Data Blocks *       | variable  | IOC State data blocks containing information about compromises on a host. See <a href="#">page 3-77</a> for a description of this data block.     |





## Configuring eStreamer

---

After you create a client application, you can connect it to the eStreamer server, start the eStreamer service, and begin exchanging data.



**Note**

---

An *eStreamer server* is a Defense Center or managed device (version 4.9 or higher) where the eStreamer service is running.

---

Perform the following tasks to manage eStreamer and client interaction:

1. Enable eStreamer on the eStreamer server.  
See [Configuring eStreamer on the eStreamer Server, page 6-1](#) for information about allowing access to the eStreamer server, adding clients, and generating authentication credentials to establish an authenticated connection.
2. If required, manually run the eStreamer service (eStreamer). You can stop, start, and view the status of the service, and use command line options to debug client-server communication.  
See [Managing the eStreamer Service, page 6-6](#) for more information.
3. Optionally, to use the eStreamer reference client to troubleshoot a connection or data stream, set up the reference client on the computer where you plan to run your client.  
See [Configuring the eStreamer Reference Client, page 6-8](#).

## Configuring eStreamer on the eStreamer Server

**License:** Any

Before the Defense Center or managed device you want to use as an eStreamer server can begin streaming events to a client application, you must configure the eStreamer server to send events to clients, provide information about the client, and generate a set of authentication credentials to use when establishing communication. You can perform all of these tasks from the Defense Center or managed device user interface.

See the following sections for more information:

- [Configuring eStreamer Event Types, page 6-2](#)
- [Adding Authentication for eStreamer Clients, page 6-3](#)
- [Using an Alternate Management Interface with eStreamer, page 6-4](#)

## Configuring eStreamer Event Types

**License:** Any

You can control which types of events the eStreamer server is able to transmit to client applications that request them.

Available event types on a managed device or a Defense Center include:

- Intrusion events
- Intrusion event packet data
- Intrusion event extra data

Available event types on a Defense Center include:

- Discovery events (this also enables connection events)
- Correlation and white list events
- Impact flag alerts
- User activity events
- Malware events
- File events

Note that the primary and secondary in a stacked 3D9900 pair report intrusion events to the Defense Center as if they were separate managed devices. If you configure communication with an eStreamer client on the primary in a 3D9900 stack, you also must configure the client on the secondary; the client configuration is not replicated. Similarly, when you delete the client, delete it in both places. If you configure an eStreamer client for a Defense Center managing 3D9900s in a stack configuration, note that the Defense Center reports all events received from both managed devices, even if the same event is reported by both.

If you configure an eStreamer client on a Defense Center in a high availability configuration, the client configuration is not replicated from the primary Defense Center to the secondary Defense Center.

**To configure the types of events captured by eStreamer:**

**Access:** Admin

---

**Step 1** Select **System > Local > Registration**.

**Step 2** Click **eStreamer**.

The eStreamer page appears with the **eStreamer Event Configuration** menu.

**Step 3** Select the check boxes next to the types of events you want eStreamer to capture and forward to requesting clients. Note that if a check box is currently cleared, that data is not being captured. Clearing a check box does not delete data that has already been captured.

You can select any or all of the following on a Defense Center or managed device:

- **Intrusion Events** to transmit intrusion events generated by managed devices.
- **Intrusion Event Packet Data** to transmit packets associated with intrusion events.
- **Intrusion Event Extra Data** to transmit additional data associated with intrusion events, such as the URI associated with the originating IP address of a client connecting to a web server through an HTTP proxy or load balancer.

You can also select any or all of the following on a Defense Center:

- **Discovery Events** to transmit host discovery events



---

**Note** If you want connection events, then you must enable discovery events.

---

- **Correlation Events** to transmit correlation and white list events.
- **Impact Flag Alerts** to transmit impact alerts generated by the Defense Center.
- **User Activity Events** to transmit user events.
- **Intrusion Event Extra Data** to transmit additional data for intrusion events, such as the URI associated with the originating IP address of a client connecting to a web server through an HTTP proxy or load balancer.



---

**Note** Note that this controls which events the eStreamer server can transmit. Your client application must still specifically request the types of events you want it to receive. For more information, see [Request Flags, page 2-11](#).

---

**Step 4** Click **Save**.

Your settings are saved and the events you selected will be forwarded to eStreamer clients when requested.

---

## Adding Authentication for eStreamer Clients

**License:** Any

Before eStreamer can send events to a client, you must add the client to the eStreamer server's peers database. You must also copy the authentication certificate generated by the eStreamer server to the client.

**To add an eStreamer client:**

**Access:** Admin

---

**Step 1** Select **Local > Registration > eStreamer**.

The **eStreamer** page appears.

**Step 2** Click **Create Client**.

The Create Client page appears.

**Step 3** In the **Hostname** field, enter the host name or IP address of the host running the eStreamer client.



---

**Note** If you use a host name, the host input server **must** be able to resolve the host to an IP address. If you have not configured DNS resolution, you should configure it first or use an IP address.

---

**Step 4** To encrypt the certificate file, enter a password in the **Password** field.

**Step 5** Click **Save**.

The eStreamer server allows the client computer to access port 8302 on the Defense Center and creates an authentication certificate to use during client-server authentication. The eStreamer Client page re-appears, with the new client listed under **eStreamer Clients**.

- Step 6** Click the download icon () next to the certificate file.
- Step 7** Save the certificate file to the directory used by your client computer for SSL authentication. The client can now connect to the Defense Center.



**Tip** To revoke access for a client, click the delete icon () next to the host you want to remove. Note that you do not need to restart the host input service on the Defense Center; access is revoked immediately.

## Using an Alternate Management Interface with eStreamer

**License:** Any

By default, eStreamer uses the primary management interface, `eth0`, to stream data to eStreamer clients. You can configure eStreamer to use the any available management interface. This example uses `eth1`, but you can use any available management interface. eStreamer can only use one interface at a time.

### To configure eStreamer to use an alternate management interface

**Access:** Admin (escalated to Root)

- Step 1** Connect the `eth1` interface on the Defense Center to a broadcast domain that is the same domain as the eStreamer clients and not the same domain as the `eth0` interface.



**Caution** Placing the `eth0` and `eth1` interfaces in the same broadcast domain impacts performance.

- Step 2** Open an SSH connection to the Defense Center.
- Step 3** Log into the Defense Center and type `sudo su` to get root access. If necessary, type your password again when prompted.
- Step 4** Type the command `configure-network -i eth1 enable` to enable the `eth1` interface.
- Step 5** Configure the `eth1` interface using the prompts.

The following prompt appears:

```
Do you wish to configure IPv4? (y or n)
```

- Step 6** Type `y` and press Enter. If you do not type `y`, you will not be prompted to configure IPv4 or IPv6.

The following prompt appears:

```
Management IP address? [10.5.60.199]
```

- Step 7** Type the desired IP address and press Enter.

The following prompt appears:

```
Management netmask? [255.255.0.0]
```

- Step 8** Type the netmask and press Enter.

The following prompt appears:

```
Management default gateway? [10.5.1.1]
```

**Step 9** The default gateway is loaded from the `eth0` interface. You cannot set the default gateway specifically for eStreamer.

**Step 10** Press Enter to accept the default gateway from the `eth0` interface.

The following prompt appears:

```
Are these settings correct? (y or n)
```

**Step 11** Check the settings. If they are correct, type `y` and press Enter.

The following prompt appears:

```
Do you wish to configure IPv6? (y or n)
```

**Step 12** IPv6 is not supported for this feature. Type `n` and press Enter.

The Defense Center confirms that the `eth1` interface is configured:

```
Updated network configuration.
```

**Step 13** After you configure `eth1`, type the command `manage_estreamer.pl` to start the eStreamer configuration utility.

The following menu appears:

```
***** Configuration Utility *****
1  status
2  disable
3  enable
4  restart
5  send IDS events
6  don't send IDS events
7  send Packet Data
8  don't send Packet Data
9  add Client
10 delete Client
11 set EStreamer Interface
0  Exit
```

```
*****
Enter choice:
```

**Step 14** Type choice `11` and press Enter.

**Step 15** Type `eth1` and press Enter.

```
*****
Enter choice: 11
Enter Interface Name% eth1
Reloading EStreamer... at /usr/local/sf/lib/perl/5.10.1/SF/EStreamer.pm line 449.
```

```
***** Configuration Utility *****
```

If you have not configured `eth1`, you will receive the warning:

```
IPv4 or IPv6 addresses are not assigned to the interface: eth1..
```

**Step 16** Type `0` and press Enter to exit the script.

At this point, eStreamer sends information out via the `eth1` interface rather than `eth0`.



#### Caution

The script can configure eStreamer to use the `eth1` interface even if the `eth1` interface is not connected. However, eStreamer cannot stream data over the interface unless the eStreamer client is on a host that is reachable from that interface.

**To configure eStreamer to use the primary management interface**

Access: Root

- 
- Step 1** Open an SSH connection to the Defense Center.
- Step 2** Log into the Defense Center.
- Step 3** Type `sudo su` to get root access. If necessary, type your password again when prompted.
- Step 4** Type the command `manage_estreamer.pl` to start the eStreamer configuration utility.

The following menu appears:

```

***** Configuration Utility *****
1  status
2  disable
3  enable
4  restart
5  send IDS events
6  don't send IDS events
7  send Packet Data
8  don't send Packet Data
9  add Client
10 delete Client
11 set EStreamer Interface
0  Exit

*****
Enter choice:

```

- Step 5** Type 11 and press Enter.
- Step 6** Type `eth0` and press Enter.
- ```

Reloading EStreamer... at /usr/local/sf/lib/perl/5.10.1/SF/EStreamer.pm line 449.
***** Configuration Utility *****

```
- Step 7** Type 0 and press Enter to exit the script.
- Step 8** Type the command `configure-network -i eth1 disable` to disable the `eth1` interface.
- 

## Managing the eStreamer Service

License: Any

You can manage the eStreamer service from the user interface. However, you can also use the command line to start and stop the service. The following sections describe eStreamer command line options:

- [Starting and Stopping the eStreamer Service, page 6-7](#) describes how to start and stop the eStreamer service.
- [eStreamer Service Options, page 6-7](#) describes the command line options available for the eStreamer service and how to use them.



## Starting and Stopping the eStreamer Service

License: Any

You can manage the eStreamer service using the `manage_estreamer.pl` script, which allows you to start, stop, reload, and restart the service.



**Tip**

You can also add command line options to the eStreamer initialization script. See [eStreamer Service Options, page 6-7](#) for more information.

The following table describes the options in the `manage_estreamer.pl` script you can use on the Defense Center or managed device.

*Table 6-1 eStreamer Management Options*

| Option  | Description                               | Select option Number... |
|---------|-------------------------------------------|-------------------------|
| enable  | Starts the service.                       | 3                       |
| disable | Stops the service.                        | 2                       |
| restart | Restarts the service.                     | 4                       |
| status  | Indicates whether the service is running. | 1                       |

## eStreamer Service Options

License: Any

eStreamer provides many service options that allow you to troubleshoot the service. You can use the options described in the following table with the eStreamer service.

*Table 6-2 eStreamer Service Options*

| Option                     | Description                                                                                                                                                                                                                                                                                                                                                                                                                         |
|----------------------------|-------------------------------------------------------------------------------------------------------------------------------------------------------------------------------------------------------------------------------------------------------------------------------------------------------------------------------------------------------------------------------------------------------------------------------------|
| <code>--debug</code>       | Runs eStreamer with debug-level logging. Errors are saved in the syslog and (when used in conjunction with <code>--nodaemon</code> ) appear on screen.                                                                                                                                                                                                                                                                              |
| <code>--nodaemon</code>    | Runs eStreamer as a foreground process. Errors appear on-screen.                                                                                                                                                                                                                                                                                                                                                                    |
| <code>--nohostcheck</code> | Runs eStreamer with host name checking disabled. That is, if the client host name does not match the host name contained in the <code>subjectAltName:dNSName</code> entry in the client certificate, access is still allowed. The <code>nohostcheck</code> option is useful in cases where the network DNS and/or NAT configuration prevent the host name check from succeeding. Note that all other security checks are performed. |
|                            |  <p><b>Caution</b> Enabling this option can negatively affect the security of your system.</p>                                                                                                                                                                                                                                                   |

Use the above options by first stopping the eStreamer service, then running it with the options you want, and finally restarting the service. For example, you can follow the instructions provided in [Running the eStreamer Service in Debug Mode, page 6-8](#) to debug eStreamer functionality.

## Running the eStreamer Service in Debug Mode

**License:** Any

You can run the eStreamer service in debug mode to view each status message the service generates on your terminal screen. Use the following procedure to do debugging.

**To run the eStreamer service in debug mode:**

**Access:** Admin

- 
- Step 1** Log into the Defense Center or managed device using SSH.
- Step 2** Use `manage_estreamer.pl` and select option 2 to stop the eStreamer service.
- Step 3** Use `./usr/local/sf/bin/sfestreamer --nodaemon --debug` to restart the eStreamer service in debug mode.
- Status messages for the service appear on the terminal screen.
- Step 4** When you are finished debugging, restart the service in normal mode by using `manage_estreamer.pl` and selecting option 4.
- 

## Configuring the eStreamer Reference Client

The *reference client* provided with the eStreamer SDK is a set of sample client scripts and Perl modules included to illustrate how the eStreamer API can be used. You can run them to familiarize yourself with eStreamer output, or you can use them to debug problems with installations of your custom-built client.

For more information on setting up the reference client, see the following sections:

- [Setting Up the eStreamer Perl Reference Client, page 6-8](#)
- [Running the eStreamer Perl Reference Client, page 6-13](#)

## Setting Up the eStreamer Perl Reference Client

To use the eStreamer Perl reference client, you must first configure the sample scripts to fit your environment and requirements.

For more information, see the following sections:

- [Understanding the eStreamer Perl Reference Client, page 6-9](#)
- [Configuring Communications for the eStreamer Reference Client, page 6-9](#)
- [Loading General Prerequisites for the Perl Reference Client, page 6-10](#)
- [Loading Prerequisites for the Perl SNMP Reference Client, page 6-10](#)
- [Understanding the Data Requested by a Test Script, page 6-10](#)
- [Modifying the Type of Data Requested by a Test Script, page 6-11](#)
- [Creating a Certificate for the Perl Reference Client, page 6-13](#)

## Understanding the eStreamer Perl Reference Client

You can download the `eStreamerSDK.zip` package, which contains the eStreamer Perl reference client, from the [Cisco support site](#). The following files are included in the `eStreamerSDK.zip` package:

- `SF_CUSTOM_ALERT.MIB`  
This MIB file is used by the `snmp.pm` file to set up traps for SNMP.
- `SFRecords.pm`  
This Perl module contains definitions of discovery message record blocks.
- `SFStreamer.pm`  
This Perl module contains the functions called by the Perl clients.
- `SFPkcs12.pm`  
This Perl module parses the client certificate and allows the client to connect to the eStreamer server.
- `SFRNABlocks.pm`  
This Perl module contains definitions of discovery data blocks.
- `ssl_test.pl`  
You can use this Perl script to test an intrusion event request over an SSL connection.
- `OutputPlugins/csv.pm`  
This Perl module prints intrusion events to a comma-separated value (CSV) format.
- `OutputPlugins/print.pm`  
This Perl module prints events to a human-readable format.
- `OutputPlugins/snmp.pm`  
This Perl module sends events to the specified SNMP server.
- `OutputPlugins/pcap.pm`  
This Perl module stores packet captures as a pcap file.
- `OutputPlugins/syslog.pm`  
This Perl module sends events to the local syslog server.

## Configuring Communications for the eStreamer Reference Client

The reference client uses the Secure Sockets Layer (SSL) for data communication. You must install OpenSSL on the computer you plan to use as a client and configure it appropriately for your environment.

**Note**

For initial installations on Linux operating systems, you must install the `libssl-dev` component as part of this download.

**To set up SSL on your client:**

- Step 1** Download OpenSSL from <http://openssl.org/source/>.
- Step 2** Unpack the source to `/usr/local/src`.
- Step 3** Configure the source by running the `Configure` script.

**Step 4** Make and install the compiled source.

## Loading General Prerequisites for the Perl Reference Client

Before you can run the eStreamer Perl reference client, you must install the `IO::Socket::SSL` Perl module on the client computer. You can install the module manually or use `cpan` to do so.



### Note

If the `Net::SSLeay` module is not installed on the client computer, install that module as well. `Net::SSLeay` is required for communication with OpenSSL.

You also must install and configure OpenSSL to support an SSL connection to the eStreamer server. For more information, see [Configuring Communications for the eStreamer Reference Client, page 6-9](#).

## Loading Prerequisites for the Perl SNMP Reference Client

Before you can run the eStreamer SNMP module of the Perl reference client, you must install the latest `net-snmp` Perl modules available for the client operating system on the client computer.

## Downloading and Unpacking the Perl Reference Client

You can download the `EventStreamerSDK.zip` file that contains the eStreamer Perl reference client the [Cisco support site](#).

Unpack the zip file to a computer running the Linux operating system, where you plan to run the client.

## Understanding the Data Requested by a Test Script

By default, when you use the `ssl_test -o` setting in the reference client, you request data as indicated in the following table.

**Table 6-3** Default Requests Made by Output Plugins

| This syntax...                                                              | Calls plugin...            | And sends...                                                                  | To request the following data...                                                                                                                                                                                                                                                                                                                                                                                                                                                                     |
|-----------------------------------------------------------------------------|----------------------------|-------------------------------------------------------------------------------|------------------------------------------------------------------------------------------------------------------------------------------------------------------------------------------------------------------------------------------------------------------------------------------------------------------------------------------------------------------------------------------------------------------------------------------------------------------------------------------------------|
| <code>./ssl_test.pl<br/>eStreamerServerName -h<br/>HostIPAddresses</code>   | N/A                        | Host request,<br>message type 5,<br>with bit 11 set to<br>1                   | Host data (see <a href="#">Host Data and Multiple Host Data Message Format, page 2-29</a> )                                                                                                                                                                                                                                                                                                                                                                                                          |
| <code>./ssl_test.pl<br/>eStreamerServerName -o<br/>print -f TextFile</code> | OutputPlugins/pri<br>nt.pm | Event stream<br>request, message<br>type 2, with bits 2<br>and 20-24 set to 1 | Event data (see <a href="#">Event Stream Request Message Format, page 2-10</a> , <a href="#">Correlation Policy Record, page 3-18</a> , <a href="#">Correlation Rule Record, page 3-20</a> , <a href="#">Metadata for Discovery Events, page 4-6</a> , <a href="#">Host Discovery Structures by Event Type, page 4-37</a> , and <a href="#">User Data Structures by Event Type, page 4-54</a> )<br><br>eStreamer transmits type 1 intrusion events because bit 2 is set on the event stream request. |

Table 6-3 Default Requests Made by Output Plugins (continued)

| This syntax...                                                                   | Calls plugin...             | And sends...                                                                       | To request the following data...                                                                                                                                                                                                                        |
|----------------------------------------------------------------------------------|-----------------------------|------------------------------------------------------------------------------------|---------------------------------------------------------------------------------------------------------------------------------------------------------------------------------------------------------------------------------------------------------|
| <code>./ssl_test.pl<br/>eStreamerServerName -o<br/>pcap -f TargetPCAPFile</code> | OutputPlugins/<br>pcap.pm   | Event stream<br>request, message<br>type 2, with bits 0<br>and 23 set to 1         | Packet data (see <a href="#">Event Data Message Format, page 2-17</a><br>and <a href="#">Packet Record 4.8.0.2+, page 3-4</a> )<br><br>eStreamer transmits only packet data because bit 0 is set<br>on the event stream request.                        |
| <code>./ssl_test.pl<br/>eStreamerServerName -o<br/>csv -f CSVFile</code>         | OutputPlugins/<br>csv.pm    | Event stream<br>request, message<br>type 2, with bits 2<br>and 23 set to 1         | Intrusion event data (see <a href="#">Event Data Message Format, page 2-17</a><br>and <a href="#">Intrusion Event Record 5.3.1+, page 3-6</a> )<br><br>eStreamer transmits type 1 intrusion events because bit<br>2 is set on the event stream request. |
| <code>./ssl_test.pl<br/>eStreamerServerName -o<br/>snmp -f SNMPServer</code>     | OutputPlugins/<br>snmp.pm   | Event stream<br>request, message<br>type 2, with bits<br>2, 20, and 23 set<br>to 1 | Intrusion event data (see <a href="#">Event Data Message Format, page 2-17</a><br>and <a href="#">Intrusion Event Record 5.3.1+, page 3-6</a> )<br><br>eStreamer transmits type 1 intrusion events because bit<br>2 is set on the event stream request. |
| <code>./ssl_test.pl<br/>eStreamerServerName -o<br/>syslog</code>                 | OutputPlugins/<br>syslog.pm | Event stream<br>request, message<br>type 2, with bits<br>2, 20, and 23 set<br>to 1 | Intrusion event data (see <a href="#">Event Data Message Format, page 2-17</a><br>and <a href="#">Intrusion Event Record 5.3.1+, page 3-6</a> )<br><br>eStreamer transmits type 1 intrusion events because bit<br>2 is set on the event stream request. |

## Modifying the Type of Data Requested by a Test Script

The `SFStreamer.pm` Perl module defines several request flag variables that you can use in the sample scripts to request data. The following table indicates what request flag variable to call to set each request flag in an event stream request message. If you want to request different data using one of the output modules, you can edit the `$FLAG` settings in the module.

For more information on the request flags, the data they request, and the product versions corresponding to each flag, see [Request Flags, page 2-11](#).

Table 6-4 Request Flag Variables Used in Sample Scripts

| Variable                            | Sets Request Flag... | To request the following data... |
|-------------------------------------|----------------------|----------------------------------|
| <code>\$FLAG_PKTS</code>            | 0                    | Packet data                      |
| <code>\$FLAG_METADATA</code>        | 1                    | Version 1 metadata               |
| <code>\$FLAG_IDS</code>             | 2                    | Type 1 intrusion events          |
| <code>\$FLAG_RNA</code>             | 3                    | Version 1 discovery events       |
| <code>\$FLAG_POLICY_EVENTS</code>   | 4                    | Version 1 correlation events     |
| <code>\$FLAG_IMPACT_ALERTS</code>   | 5                    | Intrusion impact alerts          |
| <code>\$FLAG_IDS_IMPACT_FLAG</code> | 6                    | Type 7 intrusion events          |
| <code>\$FLAG_RNA_EVENTS_2</code>    | 7                    | Version 2 discovery events       |
| <code>\$FLAG_RNA_FLOW</code>        | 8                    | Version 1 connection data        |
| <code>\$FLAG_POLICY_EVENTS_2</code> | 9                    | Version 2 correlation events     |

**Table 6-4** Request Flag Variables Used in Sample Scripts (continued)

| Variable                       | Sets Request Flag... | To request the following data...                                                                                                             |
|--------------------------------|----------------------|----------------------------------------------------------------------------------------------------------------------------------------------|
| \$FLAG_RNA_EVENTS_3            | 10                   | Version 3 discovery events                                                                                                                   |
| \$FLAG_HOST_ONLY               | 11                   | When sent in conjunction with \$FLAG_HOST_SINGLE (for one host) or \$FLAG_HOST_MULTI (for multiple hosts), only host data with no event data |
| \$FLAG_RNA_FLOW_3              | 12                   | Version 3 connection data                                                                                                                    |
| \$FLAG_POLICY_EVENTS_3         | 13                   | Version 3 correlation events                                                                                                                 |
| \$FLAG_METADATA_2              | 14                   | Version 2 metadata                                                                                                                           |
| \$FLAG_METADATA_3              | 15                   | Version 3 metadata                                                                                                                           |
| \$FLAG_RNA_EVENTS_4            | 17                   | Version 4 discovery events                                                                                                                   |
| \$FLAG_RNA_FLOW_4              | 18                   | Version 4 connection data                                                                                                                    |
| \$FLAG_POLICY_EVENTS_4         | 19                   | Version 4 correlation events                                                                                                                 |
| \$FLAG_METADATA_4              | 20                   | Version 4 metadata                                                                                                                           |
| \$FLAG_RUA                     | 21                   | User activity events                                                                                                                         |
| \$FLAG_POLICY_EVENTS_5         | 22                   | Version 5 correlation events                                                                                                                 |
| \$FLAGS_SEND_ARCHIVE_TIMESTAMP | 23                   | Extended event headers that include the timestamp applied when the event was archived for eStreamer server to process                        |
| \$FLAG_RNA_EVENTS_5            | 24                   | Version 5 discovery events                                                                                                                   |
| \$FLAG_RNA_EVENTS_6            | 25                   | Version 6 discovery events                                                                                                                   |
| \$FLAG_RNA_FLOW_5              | 26                   | Version 5 connection data                                                                                                                    |
| \$FLAG_EXTRA_DATA              | 27                   | Intrusion event extra data record                                                                                                            |
| \$FLAG_RNA_EVENTS_7            | 28                   | Version 7 discovery events                                                                                                                   |
| \$FLAG_POLICY_EVENTS_6         | 29                   | Version 6 correlation events                                                                                                                 |
| \$FLAG_DETAIL_REQUEST          | 30                   | Extended request to eStreamer                                                                                                                |

**Caution**

In all event types, prior to version 5.x, the reference client labels detection engine ID fields as sensor ID.

## Creating a Certificate for the Perl Reference Client

**License:** Any

Before you can use the Perl reference client, you must create a certificate on the Defense Center or managed device for the computer where you want to run the client. You then download the certificate file to the client computer and use it to create a certificate (`server.crt`) and RSA key file (`server.key`).

### To create a certificate for the Perl Reference Client:

**Access:** Admin

---

**Step 1** Select **Operations > Configuration > eStreamer**.

The eStreamer page appears.

**Step 2** Click **Create Client**.

The Create Client page appears.

**Step 3** In the **Hostname** field, enter the host name or IP address of the host running the eStreamer client.



---

**Note** If you use a host name, the host input server **must** be able to resolve the host to an IP address. If you have not configured DNS resolution, you should configure it first or use an IP address.

---

**Step 4** If you want to encrypt the certificate file, enter a password in the **Password** field.

**Step 5** Click **Save**.

The eStreamer server allows the client computer to access port 8302 on the Defense Center and creates an authentication certificate to use during client-server authentication. The eStreamer Client page reappears, with the new client listed under **eStreamer Clients**.

**Step 6** Click the download icon () next to the certificate file.

**Step 7** Save the certificate file to the directory used by your client computer for SSL authentication.

The client can now connect to the Defense Center.



---

**Tip** To revoke access for a client, click the delete icon () next to the host you want to remove. Note that you do not need to restart the host input service on the Defense Center; access is revoked immediately.

---

## Running the eStreamer Perl Reference Client

The eStreamer Perl reference client scripts are designed for use on a 64-bit operating system with the Linux kernel but should work on any POSIX-based 64-bit operating system, as long as the client machine meets the prerequisites defined in [Setting Up the eStreamer Perl Reference Client, page 6-8](#).

For more information, see the following sections:

- [Testing a Client Connection over SSL Using a Host Request, page 6-14](#)
- [Capturing a PCAP Using the Reference Client, page 6-14](#)
- [Capturing CSV Records Using the Reference Client, page 6-14](#)

- [Sending Records to an SNMP Server Using the Reference Client, page 6-15](#)
- [Logging Events to the Syslog Using the Reference Client, page 6-15](#)
- [Connecting to an IPv6 Address, page 6-15](#)

## Testing a Client Connection over SSL Using a Host Request

You can use the `ssl_test.pl` script to test the connection between the eStreamer server and the eStreamer client. The `ssl_test.pl` script handles any record type and prints it to STDOUT or to an output plugin you specify. When you use the `-h` option without an output option, it streams host data for the specified hosts to your terminal.



### Note

You cannot use this script to stream packet data without directing it to an output plugin because printing raw packet data to STDOUT interferes with your terminal.

Use the following syntax to use the `ssl_test.pl` script to send host data to the standard output:

```
./ssl_test.pl eStreamerServerIPAddress -h HostIPAddresses
```

For example, to test receipt of host data for the hosts in the 10.0.0.0/8 subnet over a connection to an eStreamer server with an IP address of 10.10.0.4:

```
./ssl_test.pl 10.10.0.4 -h 10.0.0.0/8
```

## Capturing a PCAP Using the Reference Client

You can use the reference client to capture streamed packet data in a PCAP file to see the structure of the data the client receives. Note that you must use `-f` to specify a target file when you use the `-o pcap` output option.

Use the following syntax to capture streamed packet data in a PCAP file using the `ssl_test.pl` script:

```
./ssl_test.pl eStreamerServerIPAddress -o pcap -f ResultingPCAPFile
```

For example, to create a PCAP file named `test.pcap` using events streamed from an eStreamer server with an IP address of 10.10.0.4:

```
./ssl_test.pl 10.10.0.4 -o pcap -f test.pcap
```

## Capturing CSV Records Using the Reference Client

You can also use the reference client to capture streamed intrusion event data in a CSV file to see the structure of the data the client receives.

Use the following syntax to run the `streamer_csv.pl` script:

```
./ssl_test.pl eStreamerServerIPAddress -o csv -f ResultingCSVFile
```

For example, to create a CSV file named `test.csv` using events streamed from an eStreamer server with an IP address of 10.10.0.4:

```
./ssl_test.pl 10.10.0.4 -o csv -f test.csv
```



## Sending Records to an SNMP Server Using the Reference Client

You can also use the reference client to stream intrusion event data to an SNMP server. Use the `-f` option to indicate the name of the SNMP trap server that should receive events. Note that this output method requires a binary named `snmptrapd` in the path and therefore only works on UNIX-like systems.

Use the following syntax to send intrusion events to an SNMP server:

```
./ssl_test.pl eStreamerServerIPAddress -o snmp  
-f SNMPServerName
```

For example, to send events to an SNMP server at 10.10.0.3 using events streamed from an eStreamer server with an IP address of 10.10.0.4:

```
./ssl_test.pl 10.10.0.4 -o snmp -f 10.10.0.3
```

## Logging Events to the Syslog Using the Reference Client

You can also use the reference client to stream intrusion events to the local syslog server on the client.

Use the following syntax to send events to the syslog:

```
./ssl_test.pl eStreamerServerIPAddress -o syslog
```

For example, to log events streamed from an eStreamer server with an IP address of 10.10.0.4:

```
./ssl_test.pl 10.10.0.4 -o syslog
```

## Connecting to an IPv6 Address

You can use the reference client to connect to a Defense Center with an IPv6 address through the primary management interface. You must have the `Socket6` and `IO::Socket::INET6` Perl modules installed on the client machine and use the `-ipv6` option or the shortened form `-i`.

Use the following syntax to specify an IPv6 address using the `ssl_test.pl` script:

```
./ssl_test.pl -ipv6 eStreamerServerIPAddress
```

or

```
./ssl_test.pl -i eStreamerServerIPAddress
```

For example, to connect to a Defense Center with the IPv6 address `2001:470:e09c:20:7c1e:5248:1bf7:2ea0` use the following:

```
./ssl_test.pl -ipv6 2001:470:e09c:20:7c1e:5248:1bf7:2ea0
```





# Data Structure Examples

This appendix contains data structure examples for selected intrusion, correlation, and discovery events. Each example is displayed in binary format to clearly display how each bit is set.

See the following sections for more information:

- [Intrusion Event Data Structure Examples](#)
- [Discovery Data Structure Examples, page A-16](#)

## Intrusion Event Data Structure Examples

This section contains examples of data structures that may be transmitted by eStreamer for intrusion events. The following examples are provided:

- [Example of an Intrusion Event for the Defense Center 5.3 +, page A-1](#)
- [Example of an Intrusion Impact Alert, page A-6](#)
- [Example of a Packet Record, page A-7](#)
- [Example of a Classification Record, page A-8](#)
- [Example of a Priority Record, page A-10](#)
- [Example of a Rule Message Record, page A-11](#)
- [Example of a Version 5.1+ User Event, page A-13](#)

### Example of an Intrusion Event for the Defense Center 5.3 +

The following diagram shows an example event record:

| Byte | 0 |   |   |   |   |   |   |   | 1 |   |    |    |    |    |    |    | 2  |    |    |    |    |    |    |    | 3  |    |    |    |    |    |    |    |   |
|------|---|---|---|---|---|---|---|---|---|---|----|----|----|----|----|----|----|----|----|----|----|----|----|----|----|----|----|----|----|----|----|----|---|
| Bit  | 0 | 1 | 2 | 3 | 4 | 5 | 6 | 7 | 8 | 9 | 10 | 11 | 12 | 13 | 14 | 15 | 16 | 17 | 18 | 19 | 20 | 21 | 22 | 23 | 24 | 25 | 26 | 27 | 28 | 29 | 30 | 31 |   |
| 1    | 0 | 0 | 0 | 0 | 0 | 0 | 0 | 0 | 0 | 0 | 0  | 0  | 0  | 0  | 0  | 0  | 1  | 0  | 0  | 0  | 0  | 0  | 0  | 0  | 0  | 0  | 0  | 0  | 0  | 0  | 1  | 0  | 0 |
| 2    | 0 | 0 | 0 | 0 | 0 | 0 | 0 | 0 | 0 | 0 | 0  | 0  | 0  | 0  | 0  | 0  | 0  | 0  | 0  | 0  | 0  | 0  | 0  | 0  | 0  | 1  | 1  | 1  | 0  | 1  | 1  | 1  | 0 |
| 3    | 0 | 0 | 0 | 0 | 0 | 0 | 0 | 0 | 0 | 0 | 0  | 0  | 0  | 0  | 0  | 0  | 0  | 0  | 0  | 0  | 0  | 0  | 0  | 0  | 0  | 1  | 1  | 0  | 0  | 1  | 0  | 0  | 0 |

Intrusion Event Data Structure Examples

| Byte | 0 |   |   |   |   |   |   | 1 |   |   |    |    |    |    | 2  |    |    |    |    |    |    | 3  |    |    |    |    |    |    |    |    |    |    |   |   |   |   |   |   |   |   |   |   |   |   |   |
|------|---|---|---|---|---|---|---|---|---|---|----|----|----|----|----|----|----|----|----|----|----|----|----|----|----|----|----|----|----|----|----|----|---|---|---|---|---|---|---|---|---|---|---|---|---|
|      | 0 | 1 | 2 | 3 | 4 | 5 | 6 | 7 | 8 | 9 | 10 | 11 | 12 | 13 | 14 | 15 | 16 | 17 | 18 | 19 | 20 | 21 | 22 | 23 | 24 | 25 | 26 | 27 | 28 | 29 | 30 | 31 |   |   |   |   |   |   |   |   |   |   |   |   |   |
| 4    | 0 | 0 | 0 | 0 | 0 | 0 | 0 | 0 | 0 | 0 | 0  | 0  | 0  | 0  | 0  | 0  | 0  | 0  | 0  | 0  | 0  | 0  | 0  | 0  | 1  | 1  | 0  | 1  | 1  | 1  | 1  | 0  |   |   |   |   |   |   |   |   |   |   |   |   |   |
| 5    | 0 | 1 | 0 | 1 | 0 | 0 | 1 | 0 | 1 | 1 | 1  | 1  | 0  | 0  | 1  | 0  | 1  | 0  | 0  | 1  | 0  | 0  | 0  | 1  | 1  | 0  | 0  | 1  | 1  | 1  | 0  | 0  |   |   |   |   |   |   |   |   |   |   |   |   |   |
| 6    | 0 | 0 | 0 | 0 | 0 | 0 | 0 | 0 | 0 | 0 | 0  | 0  | 0  | 0  | 0  | 0  | 0  | 0  | 0  | 0  | 0  | 0  | 0  | 0  | 0  | 0  | 0  | 0  | 0  | 0  | 0  | 0  |   |   |   |   |   |   |   |   |   |   |   |   |   |
| 7    | 0 | 0 | 0 | 0 | 0 | 0 | 0 | 0 | 0 | 0 | 0  | 0  | 0  | 0  | 0  | 0  | 0  | 0  | 0  | 0  | 0  | 0  | 0  | 0  | 0  | 0  | 0  | 1  | 0  | 1  | 0  | 0  | 1 |   |   |   |   |   |   |   |   |   |   |   |   |
| 8    | 0 | 0 | 0 | 0 | 0 | 0 | 0 | 0 | 0 | 0 | 0  | 0  | 0  | 0  | 0  | 0  | 0  | 0  | 0  | 0  | 0  | 0  | 0  | 0  | 1  | 1  | 0  | 1  | 1  | 1  | 1  | 0  |   |   |   |   |   |   |   |   |   |   |   |   |   |
| 9    | 0 | 0 | 0 | 0 | 0 | 0 | 0 | 0 | 0 | 0 | 0  | 0  | 0  | 0  | 0  | 0  | 0  | 0  | 0  | 0  | 0  | 0  | 0  | 0  | 0  | 0  | 0  | 0  | 0  | 0  | 0  | 1  | 0 |   |   |   |   |   |   |   |   |   |   |   |   |
| 10   | 0 | 0 | 0 | 0 | 0 | 0 | 0 | 0 | 0 | 0 | 0  | 0  | 0  | 0  | 0  | 0  | 0  | 0  | 0  | 0  | 0  | 0  | 0  | 1  | 0  | 1  | 1  | 0  | 1  | 1  | 1  | 1  | 0 | 0 | 0 | 1 |   |   |   |   |   |   |   |   |   |
| 11   | 0 | 1 | 0 | 1 | 0 | 0 | 1 | 0 | 1 | 1 | 1  | 1  | 0  | 0  | 1  | 0  | 1  | 0  | 0  | 1  | 0  | 0  | 0  | 1  | 0  | 0  | 0  | 1  | 1  | 0  | 1  | 1  |   |   |   |   |   |   |   |   |   |   |   |   |   |
| 12   | 0 | 0 | 0 | 0 | 0 | 0 | 0 | 0 | 0 | 0 | 0  | 0  | 1  | 1  | 1  | 0  | 1  | 0  | 0  | 0  | 0  | 0  | 1  | 0  | 0  | 0  | 1  | 1  | 1  | 0  | 0  | 0  |   |   |   |   |   |   |   |   |   |   |   |   |   |
| 13   | 0 | 0 | 0 | 0 | 0 | 0 | 0 | 0 | 0 | 0 | 0  | 0  | 0  | 0  | 0  | 0  | 0  | 0  | 0  | 0  | 0  | 0  | 0  | 1  | 1  | 0  | 1  | 1  | 0  | 1  | 0  | 0  | 1 | 0 | 1 |   |   |   |   |   |   |   |   |   |   |
| 14   | 0 | 0 | 0 | 0 | 0 | 0 | 0 | 0 | 0 | 0 | 0  | 0  | 0  | 0  | 0  | 0  | 0  | 0  | 0  | 0  | 0  | 0  | 0  | 0  | 0  | 0  | 0  | 0  | 0  | 0  | 0  | 0  | 0 | 0 | 0 | 1 |   |   |   |   |   |   |   |   |   |
| 15   | 0 | 0 | 0 | 0 | 0 | 0 | 0 | 0 | 0 | 0 | 0  | 0  | 0  | 0  | 0  | 0  | 0  | 0  | 0  | 0  | 0  | 0  | 0  | 0  | 0  | 0  | 0  | 0  | 0  | 0  | 0  | 0  | 0 | 0 | 0 | 1 |   |   |   |   |   |   |   |   |   |
| 16   | 0 | 0 | 0 | 0 | 0 | 0 | 0 | 0 | 0 | 0 | 0  | 0  | 0  | 0  | 0  | 0  | 0  | 0  | 0  | 0  | 0  | 0  | 0  | 0  | 0  | 0  | 0  | 0  | 0  | 0  | 0  | 0  | 0 | 0 | 0 | 1 | 0 | 0 | 0 | 1 | 1 |   |   |   |   |
| 17   | 0 | 0 | 0 | 0 | 0 | 0 | 0 | 0 | 0 | 0 | 0  | 0  | 0  | 0  | 0  | 0  | 0  | 0  | 0  | 0  | 0  | 0  | 0  | 0  | 0  | 0  | 0  | 0  | 0  | 0  | 0  | 0  | 0 | 0 | 0 | 0 | 0 | 0 | 0 | 0 | 1 |   |   |   |   |
| 18   | 0 | 0 | 0 | 0 | 0 | 0 | 0 | 0 | 0 | 0 | 0  | 0  | 0  | 0  | 0  | 0  | 0  | 0  | 0  | 0  | 0  | 0  | 0  | 0  | 0  | 0  | 0  | 0  | 0  | 0  | 0  | 0  | 0 | 0 | 0 | 0 | 0 | 0 | 0 | 0 | 0 | 0 |   |   |   |
|      | 0 | 0 | 0 | 0 | 0 | 0 | 0 | 0 | 0 | 0 | 0  | 0  | 0  | 0  | 0  | 0  | 0  | 0  | 0  | 0  | 0  | 0  | 0  | 0  | 0  | 0  | 0  | 0  | 0  | 0  | 0  | 0  | 0 | 0 | 0 | 0 | 0 | 0 | 0 | 0 | 0 | 0 |   |   |   |
|      | 0 | 0 | 0 | 0 | 0 | 0 | 0 | 0 | 0 | 0 | 0  | 0  | 0  | 0  | 0  | 0  | 0  | 0  | 0  | 0  | 0  | 0  | 0  | 0  | 0  | 0  | 0  | 0  | 0  | 0  | 0  | 0  | 0 | 0 | 0 | 0 | 0 | 0 | 0 | 0 | 0 | 0 |   |   |   |
|      | 0 | 0 | 0 | 0 | 0 | 0 | 0 | 0 | 0 | 0 | 0  | 0  | 0  | 0  | 0  | 0  | 0  | 0  | 0  | 0  | 0  | 0  | 0  | 0  | 0  | 0  | 0  | 0  | 0  | 0  | 0  | 0  | 0 | 0 | 0 | 0 | 0 | 0 | 0 | 0 | 0 | 0 |   |   |   |
|      | 0 | 0 | 0 | 1 | 0 | 1 | 1 | 0 | 0 | 0 | 0  | 0  | 0  | 0  | 0  | 0  | 0  | 0  | 0  | 0  | 0  | 0  | 0  | 0  | 0  | 0  | 0  | 0  | 0  | 0  | 0  | 0  | 0 | 0 | 0 | 0 | 0 | 0 | 0 | 0 | 0 | 0 |   |   |   |
| 19   | 0 | 0 | 0 | 0 | 0 | 0 | 0 | 0 | 0 | 0 | 0  | 0  | 0  | 0  | 0  | 0  | 0  | 0  | 0  | 0  | 0  | 0  | 0  | 0  | 0  | 0  | 0  | 0  | 0  | 0  | 0  | 0  | 0 | 0 | 0 | 0 | 0 | 0 | 0 | 0 | 0 | 0 | 0 |   |   |
|      | 0 | 0 | 0 | 0 | 0 | 0 | 0 | 0 | 0 | 0 | 0  | 0  | 0  | 0  | 0  | 0  | 0  | 0  | 0  | 0  | 0  | 0  | 0  | 0  | 0  | 0  | 0  | 0  | 0  | 0  | 0  | 0  | 0 | 0 | 0 | 0 | 0 | 0 | 0 | 0 | 0 | 0 | 0 | 0 |   |
|      | 0 | 0 | 0 | 0 | 0 | 0 | 0 | 0 | 0 | 0 | 0  | 0  | 0  | 0  | 0  | 0  | 0  | 0  | 0  | 0  | 0  | 0  | 0  | 0  | 0  | 0  | 0  | 0  | 0  | 0  | 0  | 0  | 0 | 0 | 0 | 0 | 0 | 0 | 0 | 0 | 0 | 0 | 0 | 0 |   |
|      | 0 | 0 | 1 | 1 | 0 | 1 | 1 | 1 | 0 | 0 | 0  | 0  | 1  | 0  | 1  | 1  | 1  | 0  | 0  | 0  | 0  | 0  | 0  | 0  | 0  | 0  | 0  | 0  | 0  | 0  | 0  | 0  | 0 | 0 | 0 | 0 | 0 | 0 | 0 | 0 | 0 | 0 | 0 | 0 |   |
| 20   | 1 | 1 | 1 | 1 | 1 | 1 | 0 | 1 | 1 | 1 | 1  | 0  | 1  | 0  | 0  | 0  | 0  | 0  | 0  | 0  | 0  | 0  | 0  | 0  | 0  | 0  | 0  | 1  | 1  | 0  | 1  | 0  | 1 |   |   |   |   |   |   |   |   |   |   |   |   |
| 21   | 0 | 0 | 0 | 1 | 0 | 0 | 0 | 1 | 0 | 1 | 0  | 0  | 0  | 1  | 1  | 1  | 0  | 0  | 0  | 0  | 0  | 0  | 0  | 1  | 0  | 0  | 0  | 0  | 0  | 0  | 1  | 0  |   |   |   |   |   |   |   |   |   |   |   |   |   |
| 22   | 0 | 0 | 0 | 0 | 0 | 0 | 0 | 0 | 0 | 0 | 0  | 0  | 0  | 0  | 0  | 0  | 0  | 0  | 0  | 0  | 0  | 0  | 0  | 0  | 0  | 0  | 0  | 0  | 0  | 0  | 0  | 0  | 0 | 0 | 0 | 0 | 0 | 0 | 0 | 0 | 0 | 0 | 0 | 0 |   |
| 23   | 0 | 0 | 0 | 0 | 0 | 0 | 0 | 0 | 0 | 0 | 0  | 0  | 0  | 0  | 0  | 0  | 0  | 0  | 0  | 0  | 0  | 0  | 0  | 0  | 0  | 0  | 0  | 0  | 0  | 0  | 0  | 0  | 0 | 0 | 0 | 0 | 0 | 0 | 0 | 0 | 0 | 0 | 0 | 0 | 0 |

| Byte | 0 |   |   |   |   |   |   |   | 1 |   |    |    |    |    |    |    | 2  |    |    |    |    |    |    |    | 3  |    |    |    |    |    |    |    |   |
|------|---|---|---|---|---|---|---|---|---|---|----|----|----|----|----|----|----|----|----|----|----|----|----|----|----|----|----|----|----|----|----|----|---|
|      | 0 | 1 | 2 | 3 | 4 | 5 | 6 | 7 | 8 | 9 | 10 | 11 | 12 | 13 | 14 | 15 | 16 | 17 | 18 | 19 | 20 | 21 | 22 | 23 | 24 | 25 | 26 | 27 | 28 | 29 | 30 | 31 |   |
| 24   | 0 | 1 | 0 | 0 | 0 | 0 | 1 | 1 | 1 | 0 | 1  | 1  | 0  | 1  | 1  | 1  | 0  | 1  | 0  | 0  | 1  | 1  | 0  | 0  | 1  | 1  | 0  | 0  | 1  | 1  | 0  | 1  |   |
|      | 0 | 1 | 1 | 0 | 1 | 0 | 1 | 1 | 1 | 0 | 1  | 1  | 1  | 1  | 0  | 1  | 0  | 1  | 0  | 1  | 0  | 0  | 1  | 0  | 1  | 0  | 1  | 1  | 0  | 0  | 1  | 1  |   |
|      | 0 | 0 | 0 | 0 | 1 | 0 | 1 | 0 | 0 | 1 | 1  | 0  | 1  | 1  | 1  | 0  | 1  | 0  | 1  | 0  | 1  | 0  | 0  | 1  | 1  | 0  | 0  | 1  | 1  | 1  | 1  | 0  |   |
|      | 1 | 1 | 1 | 1 | 1 | 1 | 0 | 1 | 0 | 1 | 0  | 1  | 0  | 0  | 0  | 1  | 1  | 1  | 0  | 0  | 0  | 0  | 0  | 0  | 0  | 0  | 0  | 0  | 1  | 0  | 1  | 1  | 1 |
| 25   | 0 | 0 | 0 | 0 | 0 | 0 | 0 | 0 | 0 | 0 | 0  | 0  | 0  | 0  | 0  | 0  | 0  | 0  | 0  | 0  | 0  | 0  | 0  | 0  | 0  | 0  | 0  | 0  | 0  | 0  | 0  | 0  |   |
| 26   | 0 | 0 | 0 | 0 | 0 | 0 | 0 | 0 | 0 | 0 | 0  | 0  | 0  | 0  | 0  | 0  | 0  | 0  | 0  | 0  | 0  | 0  | 0  | 0  | 0  | 0  | 0  | 0  | 0  | 0  | 0  | 0  |   |
| 27   | 0 | 1 | 1 | 1 | 0 | 1 | 1 | 1 | 0 | 0 | 1  | 1  | 0  | 1  | 0  | 1  | 1  | 0  | 0  | 1  | 0  | 1  | 1  | 0  | 0  | 1  | 1  | 0  | 1  | 0  | 0  | 1  |   |
| 28   | 0 | 0 | 0 | 0 | 0 | 0 | 0 | 0 | 0 | 0 | 0  | 0  | 0  | 0  | 0  | 0  | 0  | 0  | 0  | 0  | 0  | 0  | 0  | 1  | 0  | 0  | 1  | 1  | 0  | 1  | 0  | 0  | 1 |
| 29   | 0 | 0 | 0 | 0 | 0 | 0 | 0 | 0 | 0 | 0 | 0  | 0  | 0  | 0  | 0  | 0  | 0  | 0  | 0  | 0  | 0  | 0  | 0  | 0  | 0  | 0  | 0  | 0  | 0  | 0  | 0  | 0  | 1 |
| 30   | 1 | 0 | 1 | 1 | 0 | 0 | 1 | 0 | 0 | 0 | 1  | 0  | 0  | 0  | 1  | 1  | 1  | 0  | 1  | 0  | 1  | 0  | 1  | 0  | 0  | 0  | 1  | 0  | 0  | 1  | 0  | 0  |   |
|      | 1 | 0 | 0 | 0 | 0 | 1 | 1 | 1 | 1 | 0 | 0  | 0  | 0  | 1  | 0  | 1  | 0  | 0  | 0  | 1  | 0  | 0  | 0  | 1  | 1  | 1  | 1  | 0  | 0  | 0  | 1  | 1  |   |
|      | 1 | 0 | 1 | 0 | 1 | 0 | 0 | 0 | 0 | 0 | 1  | 0  | 1  | 0  | 1  | 1  | 1  | 1  | 0  | 1  | 1  | 0  | 1  | 1  | 0  | 0  | 0  | 1  | 1  | 0  | 0  | 1  |   |
|      | 1 | 0 | 0 | 0 | 0 | 0 | 1 | 0 | 1 | 0 | 0  | 1  | 1  | 0  | 0  | 1  | 1  | 0  | 0  | 1  | 1  | 1  | 1  | 0  | 1  | 0  | 1  | 1  | 1  | 0  | 1  | 1  |   |
| 31   | 0 | 0 | 0 | 0 | 0 | 1 | 0 | 1 | 1 | 0 | 0  | 1  | 1  | 0  | 0  | 1  | 1  | 0  | 1  | 1  | 0  | 1  | 0  | 1  | 0  | 0  | 1  | 0  | 1  | 0  | 0  |    |   |
|      | 0 | 1 | 1 | 1 | 1 | 1 | 0 | 1 | 0 | 1 | 1  | 0  | 1  | 0  | 0  | 1  | 0  | 0  | 0  | 1  | 0  | 0  | 0  | 1  | 1  | 1  | 1  | 0  | 0  | 0  | 1  | 1  |   |
|      | 1 | 0 | 0 | 0 | 1 | 1 | 1 | 1 | 0 | 0 | 1  | 1  | 1  | 0  | 0  | 1  | 1  | 0  | 0  | 0  | 1  | 1  | 1  | 0  | 1  | 0  | 1  | 0  | 1  | 1  | 1  | 1  |   |
|      | 0 | 1 | 1 | 0 | 0 | 0 | 1 | 1 | 1 | 0 | 1  | 0  | 0  | 0  | 0  | 0  | 1  | 0  | 0  | 1  | 0  | 0  | 0  | 1  | 0  | 1  | 1  | 1  | 1  | 0  | 0  | 0  |   |
| 32   | 0 | 0 | 0 | 0 | 0 | 0 | 0 | 0 | 0 | 0 | 0  | 0  | 0  | 0  | 0  | 0  | 0  | 0  | 0  | 0  | 0  | 0  | 0  | 0  | 0  | 0  | 0  | 0  | 0  | 0  | 0  | 0  |   |
|      | 0 | 0 | 0 | 0 | 0 | 0 | 0 | 0 | 0 | 0 | 0  | 0  | 0  | 0  | 0  | 0  | 0  | 0  | 0  | 0  | 0  | 0  | 0  | 0  | 0  | 0  | 0  | 0  | 0  | 0  | 0  | 0  |   |
|      | 0 | 0 | 0 | 0 | 0 | 0 | 0 | 0 | 0 | 0 | 0  | 0  | 0  | 0  | 0  | 0  | 0  | 0  | 0  | 0  | 0  | 0  | 0  | 0  | 0  | 0  | 0  | 0  | 0  | 0  | 0  | 0  |   |
|      | 0 | 0 | 0 | 0 | 0 | 0 | 0 | 0 | 0 | 0 | 0  | 0  | 0  | 0  | 0  | 0  | 0  | 0  | 0  | 0  | 0  | 0  | 0  | 0  | 0  | 0  | 0  | 0  | 0  | 0  | 0  | 0  | 0 |
| 33   | 0 | 0 | 0 | 0 | 0 | 0 | 1 | 0 | 1 | 1 | 1  | 0  | 1  | 0  | 0  | 1  | 0  | 1  | 0  | 1  | 0  | 0  | 0  | 0  | 0  | 1  | 1  | 1  | 1  | 0  | 1  | 0  |   |
|      | 0 | 1 | 1 | 1 | 1 | 1 | 0 | 1 | 0 | 1 | 1  | 0  | 1  | 0  | 0  | 1  | 0  | 0  | 0  | 1  | 0  | 0  | 0  | 1  | 1  | 1  | 1  | 0  | 0  | 0  | 1  | 1  |   |
|      | 1 | 0 | 0 | 0 | 1 | 1 | 1 | 1 | 0 | 0 | 1  | 1  | 1  | 0  | 0  | 1  | 1  | 0  | 0  | 0  | 1  | 1  | 1  | 0  | 1  | 0  | 1  | 0  | 1  | 1  | 1  | 1  |   |
|      | 0 | 1 | 1 | 0 | 0 | 0 | 1 | 1 | 1 | 0 | 1  | 0  | 0  | 0  | 0  | 0  | 1  | 0  | 0  | 1  | 0  | 0  | 0  | 1  | 0  | 1  | 1  | 1  | 1  | 0  | 0  | 0  |   |
| 34   | 0 | 0 | 0 | 0 | 0 | 0 | 0 | 0 | 0 | 0 | 0  | 0  | 0  | 0  | 0  | 0  | 0  | 0  | 0  | 0  | 0  | 0  | 0  | 0  | 0  | 0  | 0  | 0  | 0  | 0  | 0  | 0  |   |

| Byte      | 0 |   |   |   |   |   |   |   | 1 |   |    |    |    |    |    |    | 2  |    |    |    |    |    |    |    | 3  |    |    |    |    |    |    |    |
|-----------|---|---|---|---|---|---|---|---|---|---|----|----|----|----|----|----|----|----|----|----|----|----|----|----|----|----|----|----|----|----|----|----|
| Bit       | 0 | 1 | 2 | 3 | 4 | 5 | 6 | 7 | 8 | 9 | 10 | 11 | 12 | 13 | 14 | 15 | 16 | 17 | 18 | 19 | 20 | 21 | 22 | 23 | 24 | 25 | 26 | 27 | 28 | 29 | 30 | 31 |
|           | 0 | 0 | 0 | 0 | 0 | 0 | 0 | 0 | 0 | 0 | 0  | 0  | 0  | 0  | 0  | 0  | 0  | 0  | 0  | 0  | 0  | 0  | 0  | 0  | 0  | 0  | 0  | 0  | 0  | 0  | 0  | 0  |
|           | 0 | 0 | 0 | 0 | 0 | 0 | 0 | 0 | 0 | 0 | 0  | 0  | 0  | 0  | 0  | 0  | 0  | 0  | 0  | 0  | 0  | 0  | 0  | 0  | 0  | 0  | 0  | 0  | 0  | 0  | 0  | 0  |
|           | 0 | 0 | 0 | 0 | 0 | 0 | 0 | 0 | 0 | 0 | 0  | 0  | 0  | 0  | 0  | 0  | 0  | 0  | 0  | 0  | 0  | 0  | 0  | 0  | 0  | 0  | 0  | 0  | 0  | 0  | 0  | 0  |
| <b>35</b> | 0 | 1 | 0 | 1 | 0 | 0 | 1 | 0 | 1 | 1 | 1  | 1  | 0  | 0  | 1  | 0  | 1  | 0  | 0  | 1  | 0  | 0  | 0  | 1  | 0  | 0  | 0  | 1  | 1  | 0  | 1  | 1  |
| <b>36</b> | 0 | 0 | 0 | 0 | 0 | 0 | 0 | 0 | 0 | 0 | 0  | 0  | 0  | 0  | 1  | 1  | 1  | 1  | 0  | 0  | 0  | 1  | 1  | 0  | 1  | 0  | 0  | 1  | 0  | 1  | 0  |    |
| <b>37</b> | 0 | 0 | 0 | 0 | 0 | 0 | 0 | 0 | 0 | 0 | 0  | 0  | 0  | 0  | 0  | 0  | 0  | 0  | 0  | 0  | 0  | 0  | 0  | 0  | 0  | 0  | 0  | 0  | 0  | 0  | 0  |    |
| <b>38</b> | 0 | 0 | 0 | 0 | 0 | 0 | 0 | 1 | 0 | 0 | 1  | 1  | 1  | 0  | 0  |    |    |    |    |    |    |    |    |    |    |    |    |    |    |    |    |    |

In the preceding example, the following event information appears:

| Number    | Description                                                                                                                                                              |
|-----------|--------------------------------------------------------------------------------------------------------------------------------------------------------------------------|
| <b>1</b>  | The first two bytes of this line indicate the standard header value of 1. The second two bytes indicate that the message is a data message (that is, message type four). |
| <b>2</b>  | This line indicates that the message that follows is 238 bytes long.                                                                                                     |
| <b>3</b>  | This line indicates a record type value of 400, which represents an intrusion event record.                                                                              |
| <b>4</b>  | This line indicates that the event record that follows is 222 bytes long.                                                                                                |
| <b>5</b>  | This line is the timestamp when the event was saved. In this case, it was saved on Wednesday, February 5, 2014 at 19:31:40.                                              |
| <b>6</b>  | This line is reserved for future use and is populated with zeros.                                                                                                        |
| <b>7</b>  | This line indicates that the block type is 41, which is the block type for Intrusion Event records.                                                                      |
| <b>8</b>  | This line indicates that the data block is 222 bytes long.                                                                                                               |
| <b>9</b>  | This line indicates that the event is collected from sensor number 2.                                                                                                    |
| <b>10</b> | This line indicates that the event identification number is 11761.                                                                                                       |
| <b>11</b> | This line indicates that the event occurred at second 1391628571.                                                                                                        |
| <b>12</b> | This line indicates that the event occurred at microsecond 950840.                                                                                                       |
| <b>13</b> | This line indicates that the rule ID number is 28069.                                                                                                                    |
| <b>14</b> | This line indicates that the event was detected by generator ID number 1, the rules engine.                                                                              |
| <b>15</b> | This line indicates that the rule revision number is 1.                                                                                                                  |
| <b>16</b> | This line indicates that the classification identification number is 35.                                                                                                 |
| <b>17</b> | This line indicates that the priority identification number is 1.                                                                                                        |
| <b>18</b> | This line indicates that the source IP address is 10.22.8.11. Note that this field can contain either IPv4 or IPv6 addresses.                                            |

| Number | Description                                                                                                                                                                                                                                                                                                                                                                                                                                                                                                                                                                                                                 |
|--------|-----------------------------------------------------------------------------------------------------------------------------------------------------------------------------------------------------------------------------------------------------------------------------------------------------------------------------------------------------------------------------------------------------------------------------------------------------------------------------------------------------------------------------------------------------------------------------------------------------------------------------|
| 19     | This line indicates that the destination IP address is 61.55.184.10. Note that this field can contain either IPv4 or IPv6 addresses.                                                                                                                                                                                                                                                                                                                                                                                                                                                                                        |
| 20     | The first two bytes in this line indicate that the source port number is 65268, and the second two bytes indicate that the destination port number is 53.                                                                                                                                                                                                                                                                                                                                                                                                                                                                   |
| 21     | This first byte in this line indicates that UDP (17) is the protocol used in the event. The second byte is the impact flag, which indicates that the event is red (vulnerable) since the second bit is 1; that the event caused the managed event to drop the session, that the source destination host is potentially compromised, and that there is a vulnerability mapped to the client. The third byte in this line indicates that either the source or destination host is monitored by the system and is in the network map, indicating a priority 1 event (red). The last byte indicates that the event was blocked. |
| 22     | This line contains the MPLS label, if present.                                                                                                                                                                                                                                                                                                                                                                                                                                                                                                                                                                              |
| 23     | The first two bytes in this line indicate that the VLAN ID is 2. The last two bytes are reserved and set to 0.                                                                                                                                                                                                                                                                                                                                                                                                                                                                                                              |
| 24     | This line contains the unique ID number for the intrusion policy.                                                                                                                                                                                                                                                                                                                                                                                                                                                                                                                                                           |
| 25     | This line contains the internal identification number for the user. Since there is no applicable user, it is all zeros.                                                                                                                                                                                                                                                                                                                                                                                                                                                                                                     |
| 26     | This line contains the internal identification number for the web application. Since there is no web application, it is all zeros.                                                                                                                                                                                                                                                                                                                                                                                                                                                                                          |
| 27     | This line contains the internal identification number for the client application, which is 2000000617.                                                                                                                                                                                                                                                                                                                                                                                                                                                                                                                      |
| 28     | This line contains the internal identification number for the application protocol, which is 617.                                                                                                                                                                                                                                                                                                                                                                                                                                                                                                                           |
| 29     | This line contains the unique identifier for the access control rule, which is 1.                                                                                                                                                                                                                                                                                                                                                                                                                                                                                                                                           |
| 30     | This line contains the unique identifier for the access control policy.                                                                                                                                                                                                                                                                                                                                                                                                                                                                                                                                                     |
| 31     | This line contains the unique identifier for the ingress interface.                                                                                                                                                                                                                                                                                                                                                                                                                                                                                                                                                         |
| 32     | This line contains unique identifier for the egress interface. Since this event was blocked, there is no egress interface and the field is populated with zeros.                                                                                                                                                                                                                                                                                                                                                                                                                                                            |
| 33     | This line contains the unique identifier for the ingress security zone.                                                                                                                                                                                                                                                                                                                                                                                                                                                                                                                                                     |
| 34     | This line contains the unique identifier for the egress security zone. Since this event was blocked, there is no egress interface and the field is populated with zeros.                                                                                                                                                                                                                                                                                                                                                                                                                                                    |
| 35     | This line contains the Unix timestamp of the connection event associated with the intrusion event.                                                                                                                                                                                                                                                                                                                                                                                                                                                                                                                          |
| 36     | The first two bytes in this line indicate the numerical ID of the Snort instance on the managed device that generated the connection event. The remaining two bytes indicate the value used to distinguish between connection events that happen during the same second.                                                                                                                                                                                                                                                                                                                                                    |
| 37     | The first two bytes in this line indicate the code for the country of the source host. The remaining two bytes indicate the code for the country of the destination host.                                                                                                                                                                                                                                                                                                                                                                                                                                                   |
| 38     | This line indicates the ID number of the compromise associated with this event, if any.                                                                                                                                                                                                                                                                                                                                                                                                                                                                                                                                     |

## Example of an Intrusion Impact Alert

The following diagram shows an example intrusion impact alert record:

| Byte | 0 |   |   |   |   |   |   | 1 |   |   |    |    |    |    | 2  |    |    |    |    |    |    | 3  |    |    |    |    |    |    |    |    |    |    |   |   |   |   |   |   |   |   |   |   |   |   |   |   |   |   |   |   |   |   |   |   |   |
|------|---|---|---|---|---|---|---|---|---|---|----|----|----|----|----|----|----|----|----|----|----|----|----|----|----|----|----|----|----|----|----|----|---|---|---|---|---|---|---|---|---|---|---|---|---|---|---|---|---|---|---|---|---|---|---|
|      | 0 | 1 | 2 | 3 | 4 | 5 | 6 | 7 | 8 | 9 | 10 | 11 | 12 | 13 | 14 | 15 | 16 | 17 | 18 | 19 | 20 | 21 | 22 | 23 | 24 | 25 | 26 | 27 | 28 | 29 | 30 | 31 |   |   |   |   |   |   |   |   |   |   |   |   |   |   |   |   |   |   |   |   |   |   |   |
| 1    | 0 | 0 | 0 | 0 | 0 | 0 | 0 | 0 | 0 | 0 | 0  | 0  | 0  | 0  | 0  | 1  | 0  | 0  | 0  | 0  | 0  | 0  | 0  | 0  | 0  | 0  | 0  | 0  | 0  | 0  | 0  | 0  | 1 | 0 | 0 |   |   |   |   |   |   |   |   |   |   |   |   |   |   |   |   |   |   |   |   |
| 2    | 0 | 0 | 0 | 0 | 0 | 0 | 0 | 0 | 0 | 0 | 0  | 0  | 0  | 0  | 0  | 0  | 0  | 0  | 0  | 0  | 0  | 0  | 0  | 0  | 0  | 0  | 0  | 0  | 0  | 0  | 0  | 1  | 1 | 0 | 1 | 1 | 0 |   |   |   |   |   |   |   |   |   |   |   |   |   |   |   |   |   |   |
| 3    | 0 | 0 | 0 | 0 | 0 | 0 | 0 | 0 | 0 | 0 | 0  | 0  | 0  | 0  | 0  | 0  | 0  | 0  | 0  | 0  | 0  | 0  | 0  | 0  | 0  | 0  | 0  | 0  | 0  | 0  | 0  | 0  | 0 | 0 | 1 | 0 | 0 | 1 |   |   |   |   |   |   |   |   |   |   |   |   |   |   |   |   |   |
| 4    | 0 | 0 | 0 | 0 | 0 | 0 | 0 | 0 | 0 | 0 | 0  | 0  | 0  | 0  | 0  | 0  | 0  | 0  | 0  | 0  | 0  | 0  | 0  | 0  | 0  | 0  | 0  | 0  | 0  | 0  | 0  | 1  | 1 | 0 | 0 | 1 | 0 |   |   |   |   |   |   |   |   |   |   |   |   |   |   |   |   |   |   |
| 5    | 0 | 0 | 0 | 0 | 0 | 0 | 0 | 0 | 0 | 0 | 0  | 0  | 0  | 0  | 0  | 0  | 0  | 0  | 0  | 0  | 0  | 0  | 0  | 0  | 0  | 0  | 0  | 0  | 0  | 0  | 0  | 1  | 0 | 1 | 0 | 0 | 0 |   |   |   |   |   |   |   |   |   |   |   |   |   |   |   |   |   |   |
| 6    | 0 | 0 | 0 | 0 | 0 | 0 | 0 | 0 | 0 | 0 | 0  | 0  | 0  | 0  | 0  | 0  | 0  | 0  | 0  | 0  | 0  | 0  | 0  | 0  | 0  | 0  | 0  | 0  | 0  | 0  | 1  | 1  | 0 | 0 | 1 | 0 | 0 |   |   |   |   |   |   |   |   |   |   |   |   |   |   |   |   |   |   |
| 7    | 0 | 0 | 0 | 0 | 0 | 0 | 0 | 0 | 0 | 0 | 0  | 0  | 0  | 0  | 1  | 1  | 0  | 0  | 0  | 1  | 0  | 0  | 1  | 0  | 0  | 1  | 0  | 0  | 0  | 1  | 0  | 1  | 0 | 0 | 0 | 0 |   |   |   |   |   |   |   |   |   |   |   |   |   |   |   |   |   |   |   |
| 8    | 0 | 0 | 0 | 0 | 0 | 0 | 0 | 0 | 0 | 0 | 0  | 0  | 0  | 0  | 0  | 0  | 0  | 0  | 0  | 0  | 0  | 0  | 0  | 0  | 0  | 0  | 0  | 0  | 0  | 0  | 0  | 0  | 0 | 0 | 0 | 0 | 1 | 0 |   |   |   |   |   |   |   |   |   |   |   |   |   |   |   |   |   |
| 9    | 0 | 1 | 0 | 0 | 0 | 0 | 0 | 0 | 1 | 1 | 0  | 0  | 1  | 1  | 0  | 1  | 1  | 0  | 1  | 1  | 0  | 1  | 1  | 0  | 1  | 1  | 1  | 1  | 0  | 0  | 1  | 0  | 1 | 0 | 1 | 0 | 0 |   |   |   |   |   |   |   |   |   |   |   |   |   |   |   |   |   |   |
| 10   | 0 | 0 | 0 | 0 | 0 | 0 | 0 | 0 | 0 | 0 | 0  | 0  | 0  | 0  | 0  | 0  | 0  | 0  | 0  | 0  | 0  | 0  | 0  | 0  | 0  | 0  | 0  | 0  | 0  | 0  | 0  | 0  | 0 | 0 | 0 | 0 | 0 | 1 |   |   |   |   |   |   |   |   |   |   |   |   |   |   |   |   |   |
| 11   | 1 | 0 | 1 | 0 | 1 | 1 | 0 | 0 | 0 | 0 | 0  | 1  | 0  | 0  | 0  | 0  | 0  | 0  | 0  | 0  | 0  | 0  | 0  | 0  | 0  | 0  | 0  | 0  | 1  | 0  | 0  | 0  | 1 | 0 | 1 | 1 | 0 |   |   |   |   |   |   |   |   |   |   |   |   |   |   |   |   |   |   |
| 12   | 0 | 0 | 0 | 0 | 0 | 0 | 0 | 0 | 0 | 0 | 0  | 0  | 0  | 0  | 0  | 0  | 0  | 0  | 0  | 0  | 0  | 0  | 0  | 0  | 0  | 0  | 0  | 0  | 0  | 0  | 0  | 0  | 0 | 0 | 0 | 0 | 0 | 0 |   |   |   |   |   |   |   |   |   |   |   |   |   |   |   |   |   |
| 13   | 0 | 0 | 0 | 0 | 0 | 0 | 0 | 0 | 0 | 0 | 0  | 0  | 0  | 0  | 0  | 0  | 0  | 0  | 0  | 0  | 0  | 0  | 0  | 0  | 0  | 0  | 0  | 0  | 0  | 0  | 0  | 0  | 0 | 0 | 0 | 0 | 0 | 0 |   |   |   |   |   |   |   |   |   |   |   |   |   |   |   |   |   |
| 14   | 0 | 0 | 0 | 0 | 0 | 0 | 0 | 0 | 0 | 0 | 0  | 0  | 0  | 0  | 0  | 0  | 0  | 0  | 0  | 0  | 0  | 0  | 0  | 0  | 0  | 0  | 0  | 0  | 0  | 0  | 0  | 0  | 0 | 0 | 1 | 0 | 0 | 1 | 0 |   |   |   |   |   |   |   |   |   |   |   |   |   |   |   |   |
| 15   | 0 | 1 | 0 | 1 | 0 | 1 | 1 | 0 | 0 | 1 | 1  | 1  | 0  | 1  | 0  | 1  | 0  | 1  | 1  | 0  | 1  | 1  | 0  | 0  | 0  | 1  | 1  | 0  | 1  | 1  | 1  | 1  | 0 | 0 | 1 | 1 | 0 | 0 | 0 | 1 | 0 | 1 | 1 | 0 | 0 | 0 | 1 | 0 | 1 | 1 | 0 | 0 | 0 | 1 | 0 |
|      | 0 | 1 | 1 | 0 | 1 | 1 | 0 | 0 | 0 | 1 | 1  | 0  | 0  | 1  | 0  | 1  | 0  | 1  | 1  | 0  | 0  | 0  | 0  | 1  | 0  | 1  | 1  | 0  | 0  | 0  | 1  | 0  | 1 | 1 | 0 | 0 | 0 | 1 | 0 |   |   |   |   |   |   |   |   |   |   |   |   |   |   |   |   |

In the preceding example, the following information appears:

| Number | Description                                                                                                                                                     |
|--------|-----------------------------------------------------------------------------------------------------------------------------------------------------------------|
| 1      | The first two bytes of this line indicate the standard header value of 1. The second two bytes indicate that the message is a data message (message type four). |
| 2      | This line indicates that the message that follows is 58 bytes long.                                                                                             |
| 3      | This line indicates a record type value of 9, which represents an intrusion impact alert record.                                                                |



| Number | Description                                                                                                                                                                                                                                     |
|--------|-------------------------------------------------------------------------------------------------------------------------------------------------------------------------------------------------------------------------------------------------|
| 4      | This line indicates that the data that follows is 50 bytes long.                                                                                                                                                                                |
| 5      | This line contains a value of 20, indicating that an intrusion impact alert data block follows.                                                                                                                                                 |
| 6      | This line indicates that the length of the impact alert block, including the impact alert block header, is 50 bytes.                                                                                                                            |
| 7      | This line indicates that the event identification number is 201256.                                                                                                                                                                             |
| 8      | This line indicates that the event is collected from device number 2.                                                                                                                                                                           |
| 9      | This line indicates that the event occurred at second 1087223700.                                                                                                                                                                               |
| 10     | This line indicates that 1 (red, vulnerable) is the impact level associated with the event.                                                                                                                                                     |
| 11     | This line indicates that the IP address associated with the violation event is 172.16.1.22.                                                                                                                                                     |
| 12     | This line indicates that there is no destination IP address associated with the violation (values are set to 0).                                                                                                                                |
| 13     | This line indicates that a string block follows, containing a string block length and a text string which, in this case, contains the impact name. For more information about string blocks, see <a href="#">String Data Block, page 3-48</a> . |
| 14     | This line indicates that the total length of the string block, including the string block indicator and length is 18 bytes. This includes 10 bytes for the impact description and 8 bytes for the string header.                                |
| 15     | This line indicates that the description of the impact is “Vulnerable.”                                                                                                                                                                         |

## Example of a Packet Record

The following diagram shows an example packet record:

| Byte | 0 |   |   |   |   |   |   |   | 1 |   |    |    |    |    |    |    | 2  |    |    |    |    |    |    |    | 3  |    |    |    |    |    |    |    |   |   |   |
|------|---|---|---|---|---|---|---|---|---|---|----|----|----|----|----|----|----|----|----|----|----|----|----|----|----|----|----|----|----|----|----|----|---|---|---|
| Bit  | 0 | 1 | 2 | 3 | 4 | 5 | 6 | 7 | 8 | 9 | 10 | 11 | 12 | 13 | 14 | 15 | 16 | 17 | 18 | 19 | 20 | 21 | 22 | 23 | 24 | 25 | 26 | 27 | 28 | 29 | 30 | 31 |   |   |   |
| 1    | 0 | 0 | 0 | 0 | 0 | 0 | 0 | 0 | 0 | 0 | 0  | 0  | 0  | 0  | 0  | 1  | 0  | 0  | 0  | 0  | 0  | 0  | 0  | 0  | 0  | 0  | 0  | 0  | 0  | 0  | 0  | 1  | 0 | 0 |   |
| 2    | 0 | 0 | 0 | 0 | 0 | 0 | 0 | 0 | 0 | 0 | 0  | 0  | 0  | 0  | 0  | 0  | 0  | 0  | 0  | 0  | 0  | 0  | 0  | 1  | 1  | 1  | 1  | 1  | 0  | 1  | 1  | 1  | 0 | 1 |   |
| 3    | 0 | 0 | 0 | 0 | 0 | 0 | 0 | 0 | 0 | 0 | 0  | 0  | 0  | 0  | 0  | 0  | 0  | 0  | 0  | 0  | 0  | 0  | 0  | 0  | 0  | 0  | 0  | 0  | 0  | 0  | 0  | 0  | 1 | 0 |   |
| 4    | 0 | 0 | 0 | 0 | 0 | 0 | 0 | 0 | 0 | 0 | 0  | 0  | 0  | 0  | 0  | 0  | 0  | 0  | 0  | 0  | 0  | 0  | 0  | 1  | 1  | 1  | 1  | 1  | 0  | 1  | 0  | 1  | 0 | 1 |   |
| 5    | 0 | 0 | 0 | 0 | 0 | 0 | 0 | 0 | 0 | 0 | 0  | 0  | 0  | 0  | 0  | 0  | 0  | 0  | 0  | 0  | 0  | 0  | 0  | 0  | 0  | 0  | 0  | 0  | 0  | 0  | 0  | 0  | 1 | 1 |   |
| 6    | 0 | 0 | 0 | 0 | 0 | 0 | 0 | 0 | 0 | 0 | 0  | 0  | 0  | 0  | 1  | 0  | 1  | 1  | 1  | 1  | 1  | 1  | 0  | 1  | 1  | 0  | 1  | 1  | 0  | 0  | 1  | 1  | 0 | 0 |   |
| 7    | 0 | 0 | 1 | 1 | 1 | 1 | 1 | 1 | 0 | 0 | 0  | 0  | 0  | 1  | 0  | 0  | 0  | 1  | 1  | 1  | 1  | 1  | 1  | 1  | 1  | 0  | 1  | 1  | 1  | 0  | 0  | 1  | 0 | 0 |   |
| 8    | 0 | 0 | 1 | 1 | 1 | 1 | 1 | 1 | 0 | 0 | 0  | 0  | 0  | 1  | 0  | 0  | 0  | 1  | 1  | 1  | 1  | 1  | 1  | 1  | 1  | 0  | 1  | 1  | 1  | 0  | 1  | 0  | 0 | 0 |   |
| 9    | 0 | 0 | 0 | 0 | 0 | 0 | 0 | 0 | 0 | 0 | 0  | 0  | 0  | 0  | 0  | 0  | 1  | 1  | 1  | 1  | 1  | 0  | 0  | 0  | 1  | 1  | 0  | 0  | 1  | 1  | 1  | 0  | 1 | 0 |   |
| 10   | 0 | 0 | 0 | 0 | 0 | 0 | 0 | 0 | 0 | 0 | 0  | 0  | 0  | 0  | 0  | 0  | 0  | 0  | 0  | 0  | 0  | 0  | 0  | 0  | 0  | 0  | 0  | 0  | 0  | 0  | 0  | 0  | 0 | 0 | 1 |

| Byte | 0 |   |   |   |   |   |   |   | 1 |   |    |    |    |    |    |    | 2  |    |    |    |    |    |    |    | 3  |    |    |    |    |    |    |    |
|------|---|---|---|---|---|---|---|---|---|---|----|----|----|----|----|----|----|----|----|----|----|----|----|----|----|----|----|----|----|----|----|----|
| Bit  | 0 | 1 | 2 | 3 | 4 | 5 | 6 | 7 | 8 | 9 | 10 | 11 | 12 | 13 | 14 | 15 | 16 | 17 | 18 | 19 | 20 | 21 | 22 | 23 | 24 | 25 | 26 | 27 | 28 | 29 | 30 | 31 |
| 11   | 0 | 0 | 0 | 0 | 0 | 0 | 0 | 0 | 0 | 0 | 0  | 0  | 0  | 0  | 0  | 0  | 0  | 0  | 0  | 0  | 0  | 0  | 0  | 0  | 1  | 1  | 1  | 1  | 0  | 0  | 0  | 1  |
| 12   | 0 | 0 | 1 | 1 | 0 | 0 | 0 | 0 | 0 | 1 | 1  | 1  | 1  | 0  | 0  | 0  | 0  | 1  | 1  | 0  | 0  | 0  | 0  | 0  | 0  | 1  | 1  | 0  | 0  | 0  | 0  | 0  |
|      | 0 | 0 | 1 | 1 | 0 | 0 | 0 | 0 | 0 | 1 | 1  | 0  | 0  | 0  | 0  | 0  | 1  | 1  | 1  | 0  | 1  | 0  | 0  | 0  | 1  | 0  | 0  | 0  | 0  | 1  | 0  | 0  |

In the preceding example, the following packet information appears:

| Number | Description                                                                                                                                                     |
|--------|-----------------------------------------------------------------------------------------------------------------------------------------------------------------|
| 1      | The first two bytes of this line indicate the standard header value of 1. The second two bytes indicate that the message is a data message (message type four). |
| 2      | This line indicates that the message that follows is 989 bytes long.                                                                                            |
| 3      | This line indicates a record type value of 2, which represents a packet record.                                                                                 |
| 4      | This line indicates that the packet record that follows is 981 bytes long.                                                                                      |
| 5      | This line indicates that the event is collected from device number 3.                                                                                           |
| 6      | This line indicates that the event identification number is 195430.                                                                                             |
| 7      | This line indicates that the event occurred at second 1057259378.                                                                                               |
| 8      | This line indicates that the packet was collected at second 1057259380.                                                                                         |
| 9      | This line indicates that the packet was collected at microsecond 254365.                                                                                        |
| 10     | This line indicates that the link type is 1 (Ethernet layer).                                                                                                   |
| 11     | This line indicates that the packet data that follows is 953 bytes long.                                                                                        |
| 12     | This line and the following line show the actual payload data. Note that the actual data is 953 bytes and has been truncated for the sake of this example.      |

## Example of a Classification Record

The following diagram shows an example classification record:

| Byte | 0 |   |   |   |   |   |   |   | 1 |   |    |    |    |    |    |    | 2  |    |    |    |    |    |    |    | 3  |    |    |    |    |    |    |    |
|------|---|---|---|---|---|---|---|---|---|---|----|----|----|----|----|----|----|----|----|----|----|----|----|----|----|----|----|----|----|----|----|----|
| Bit  | 0 | 1 | 2 | 3 | 4 | 5 | 6 | 7 | 8 | 9 | 10 | 11 | 12 | 13 | 14 | 15 | 16 | 17 | 18 | 19 | 20 | 21 | 22 | 23 | 24 | 25 | 26 | 27 | 28 | 29 | 30 | 31 |
| 1    | 0 | 0 | 0 | 0 | 0 | 0 | 0 | 0 | 0 | 0 | 0  | 0  | 0  | 0  | 0  | 1  | 0  | 0  | 0  | 0  | 0  | 0  | 0  | 0  | 0  | 0  | 0  | 0  | 0  | 0  | 0  | 1  |
| 2    | 0 | 0 | 0 | 0 | 0 | 0 | 0 | 0 | 0 | 0 | 0  | 0  | 0  | 0  | 0  | 0  | 0  | 0  | 0  | 0  | 0  | 0  | 0  | 0  | 0  | 0  | 1  | 0  | 1  | 1  | 1  | 0  |
| 3    | 0 | 0 | 0 | 0 | 0 | 0 | 0 | 0 | 0 | 0 | 0  | 0  | 0  | 0  | 0  | 0  | 0  | 0  | 0  | 0  | 0  | 0  | 0  | 0  | 0  | 1  | 0  | 0  | 0  | 0  | 0  | 1  |
| 4    | 0 | 0 | 0 | 0 | 0 | 0 | 0 | 0 | 0 | 0 | 0  | 0  | 0  | 0  | 0  | 0  | 0  | 0  | 0  | 0  | 0  | 0  | 0  | 0  | 0  | 1  | 0  | 1  | 0  | 1  | 0  | 0  |

| Byte | 0 |   |   |   |   |   |   |   | 1 |   |    |    |    |    |    |    | 2  |    |    |    |    |    |    |    | 3  |    |    |    |    |    |    |    |   |   |   |   |   |   |   |   |   |
|------|---|---|---|---|---|---|---|---|---|---|----|----|----|----|----|----|----|----|----|----|----|----|----|----|----|----|----|----|----|----|----|----|---|---|---|---|---|---|---|---|---|
| Bit  | 0 | 1 | 2 | 3 | 4 | 5 | 6 | 7 | 8 | 9 | 10 | 11 | 12 | 13 | 14 | 15 | 16 | 17 | 18 | 19 | 20 | 21 | 22 | 23 | 24 | 25 | 26 | 27 | 28 | 29 | 30 | 31 |   |   |   |   |   |   |   |   |   |
| 5    | 0 | 0 | 0 | 0 | 0 | 0 | 0 | 0 | 0 | 0 | 0  | 0  | 0  | 0  | 0  | 0  | 0  | 0  | 0  | 0  | 0  | 0  | 0  | 0  | 0  | 0  | 0  | 0  | 0  | 0  | 0  | 0  | 0 | 0 | 1 | 0 | 0 | 0 | 0 | 0 |   |
| 6    | 0 | 0 | 0 | 0 | 0 | 0 | 0 | 0 | 0 | 0 | 0  | 0  | 0  | 0  | 1  | 1  | 1  | 0  | 1  | 1  | 0  | 1  | 0  | 0  | 0  | 0  | 1  | 1  | 1  | 0  | 0  | 1  | 0 | 0 | 0 | 0 | 0 | 0 | 0 | 0 | 0 |
| 7    | 0 | 1 | 1 | 0 | 1 | 1 | 1 | 0 | 1 | 1 | 0  | 1  | 1  | 0  | 1  | 0  | 1  | 0  | 0  | 1  | 1  | 0  | 0  | 0  | 0  | 0  | 1  | 0  | 1  | 1  | 0  | 1  | 1 | 0 | 1 | 1 | 0 | 1 | 1 | 0 | 1 |
| 8    | 1 | 0 | 0 | 1 | 1 | 1 | 0 | 1 | 1 | 1 | 0  | 0  | 0  | 1  | 1  | 0  | 0  | 0  | 0  | 0  | 0  | 0  | 0  | 0  | 0  | 1  | 0  | 1  | 1  | 1  | 0  | 1  | 0 | 0 | 0 | 0 | 0 | 0 | 0 | 0 | 0 |
| 9    | 0 | 0 | 0 | 0 | 0 | 0 | 0 | 0 | 0 | 0 | 0  | 0  | 0  | 0  | 0  | 0  | 0  | 0  | 0  | 0  | 0  | 0  | 0  | 0  | 0  | 0  | 0  | 0  | 0  | 0  | 0  | 0  | 0 | 0 | 0 | 0 | 0 | 0 | 0 | 0 | 0 |

In the preceding example, the following event information appears:

| Number | Description                                                                                                                                                    |
|--------|----------------------------------------------------------------------------------------------------------------------------------------------------------------|
| 1      | The first two bytes of the line indicate the standard header value of 1. The second two bytes indicate that the message is a data message (message type four). |
| 2      | This line indicates that the message that follows is 92 bytes long.                                                                                            |

| Number | Description                                                                                                                                                                                                                                                                                                                     |
|--------|---------------------------------------------------------------------------------------------------------------------------------------------------------------------------------------------------------------------------------------------------------------------------------------------------------------------------------|
| 3      | This line indicates a record type value of 67, which represents a classification record.                                                                                                                                                                                                                                        |
| 4      | This line indicates that the classification record that follows is 84 bytes long.                                                                                                                                                                                                                                               |
| 5      | This line indicates that the Classification ID is 35.                                                                                                                                                                                                                                                                           |
| 6      | The first two bytes of this line indicate that the classification name that follows it is 15 bytes long. The second two bytes begin the classification name itself, which, in this case, is "trojan-activity".                                                                                                                  |
| 7      | The first byte in this line is a continuation of the classification name described in line 6. The next two bytes in this line indicate that the classification description that follows it is 29 bytes long. The remaining byte begins the classification description, which, in this case, is "A Network Trojan was Detected." |
| 8      | This line indicates the classification ID number that acts as a unique identifier for the classification.                                                                                                                                                                                                                       |
| 9      | This line indicates the classification revision ID number that acts as a unique identifier for the classification revision, which is null because there are no revisions to the classification.                                                                                                                                 |

## Example of a Priority Record

The following example shows a sample priority record:

| Byte | 0 |   |   |   |   |   |   |   | 1 |   |    |    |    |    |    |    | 2  |    |    |    |    |    |    |    | 3  |    |    |    |    |    |    |    |
|------|---|---|---|---|---|---|---|---|---|---|----|----|----|----|----|----|----|----|----|----|----|----|----|----|----|----|----|----|----|----|----|----|
| Bit  | 0 | 1 | 2 | 3 | 4 | 5 | 6 | 7 | 8 | 9 | 10 | 11 | 12 | 13 | 14 | 15 | 16 | 17 | 18 | 19 | 20 | 21 | 22 | 23 | 24 | 25 | 26 | 27 | 28 | 29 | 30 | 31 |
| 1    | 0 | 0 | 0 | 0 | 0 | 0 | 0 | 0 | 0 | 0 | 0  | 0  | 0  | 0  | 0  | 1  | 0  | 0  | 0  | 0  | 0  | 0  | 0  | 0  | 0  | 0  | 0  | 0  | 0  | 0  | 0  | 0  |
| 2    | 0 | 0 | 0 | 0 | 0 | 0 | 0 | 0 | 0 | 0 | 0  | 0  | 0  | 0  | 0  | 0  | 0  | 0  | 0  | 0  | 0  | 0  | 0  | 0  | 0  | 0  | 0  | 0  | 0  | 0  | 1  | 0  |
| 3    | 0 | 0 | 0 | 0 | 0 | 0 | 0 | 0 | 0 | 0 | 0  | 0  | 0  | 0  | 0  | 0  | 0  | 0  | 0  | 0  | 0  | 0  | 0  | 0  | 0  | 0  | 0  | 0  | 0  | 0  | 0  | 0  |
| 4    | 0 | 0 | 0 | 0 | 0 | 0 | 0 | 0 | 0 | 0 | 0  | 0  | 0  | 0  | 0  | 0  | 0  | 0  | 0  | 0  | 0  | 0  | 0  | 0  | 0  | 0  | 0  | 0  | 0  | 0  | 1  | 0  |
| 5    | 0 | 0 | 0 | 0 | 0 | 0 | 0 | 0 | 0 | 0 | 0  | 0  | 0  | 0  | 0  | 0  | 0  | 0  | 0  | 0  | 0  | 0  | 0  | 0  | 0  | 0  | 0  | 0  | 0  | 0  | 0  | 0  |
| 6    | 0 | 0 | 0 | 0 | 0 | 0 | 0 | 0 | 0 | 0 | 0  | 0  | 0  | 1  | 0  | 0  | 0  | 1  | 1  | 0  | 1  | 0  | 0  | 0  | 1  | 1  | 0  | 1  | 0  | 0  | 1  | 1  |
|      | 0 | 1 | 1 | 0 | 0 | 1 | 1 | 1 | 0 | 1 | 1  | 0  | 1  | 0  | 0  | 0  |    |    |    |    |    |    |    |    |    |    |    |    |    |    |    |    |

In the preceding example, the following event information appears:

| Number | Description                                                                                                                                                     |
|--------|-----------------------------------------------------------------------------------------------------------------------------------------------------------------|
| 1      | The first two bytes in this line indicate the standard header value of 1. The second two bytes indicate that the message is a data message (message type four). |
| 2      | This line indicates that the message that follows is 16 bytes.                                                                                                  |

| Number | Description                                                                                                                                                                                              |
|--------|----------------------------------------------------------------------------------------------------------------------------------------------------------------------------------------------------------|
| 3      | This line indicates a record type value of 4, which represents a priority record.                                                                                                                        |
| 4      | This line indicates that the priority record that follows is 8 bytes long.                                                                                                                               |
| 5      | This line indicates that the priority ID is one.                                                                                                                                                         |
| 6      | The first two bytes of this line indicate that there are four bytes included in the priority name. The second two bytes plus the two bytes on the following line show the priority name itself ("high"). |

## Example of a Rule Message Record

The following example shows a sample rule record:

| Byte | 0 |   |   |   |   |   |   |   | 1 |   |    |    |    |    |    |    | 2  |    |    |    |    |    |    |    | 3  |    |    |    |    |    |    |    |   |   |   |   |   |   |   |
|------|---|---|---|---|---|---|---|---|---|---|----|----|----|----|----|----|----|----|----|----|----|----|----|----|----|----|----|----|----|----|----|----|---|---|---|---|---|---|---|
|      | 0 | 1 | 2 | 3 | 4 | 5 | 6 | 7 | 8 | 9 | 10 | 11 | 12 | 13 | 14 | 15 | 16 | 17 | 18 | 19 | 20 | 21 | 22 | 23 | 24 | 25 | 26 | 27 | 28 | 29 | 30 | 31 |   |   |   |   |   |   |   |
| 1    | 0 | 0 | 0 | 0 | 0 | 0 | 0 | 0 | 0 | 0 | 0  | 0  | 0  | 0  | 0  | 1  | 0  | 0  | 0  | 0  | 0  | 0  | 0  | 0  | 0  | 0  | 0  | 0  | 0  | 0  | 0  | 1  | 0 | 0 |   |   |   |   |   |
| 2    | 0 | 0 | 0 | 0 | 0 | 0 | 0 | 0 | 0 | 0 | 0  | 0  | 0  | 0  | 0  | 0  | 0  | 0  | 0  | 0  | 0  | 0  | 0  | 0  | 0  | 0  | 0  | 0  | 0  | 0  | 1  | 0  | 0 | 0 | 0 | 0 | 1 |   |   |
| 3    | 0 | 0 | 0 | 0 | 0 | 0 | 0 | 0 | 0 | 0 | 0  | 0  | 0  | 0  | 0  | 0  | 0  | 0  | 0  | 0  | 0  | 0  | 0  | 0  | 0  | 0  | 0  | 0  | 0  | 0  | 1  | 0  | 0 | 0 | 0 | 1 | 0 |   |   |
| 4    | 0 | 0 | 0 | 0 | 0 | 0 | 0 | 0 | 0 | 0 | 0  | 0  | 0  | 0  | 0  | 0  | 0  | 0  | 0  | 0  | 0  | 0  | 0  | 0  | 0  | 0  | 0  | 0  | 0  | 0  | 1  | 1  | 1 | 1 | 0 | 0 | 1 |   |   |
| 5    | 0 | 0 | 0 | 0 | 0 | 0 | 0 | 0 | 0 | 0 | 0  | 0  | 0  | 0  | 0  | 0  | 0  | 0  | 0  | 0  | 0  | 0  | 0  | 0  | 0  | 0  | 0  | 0  | 0  | 0  | 0  | 0  | 0 | 0 | 0 | 0 | 0 | 1 |   |
| 6    | 0 | 0 | 0 | 0 | 0 | 0 | 0 | 0 | 0 | 0 | 0  | 0  | 0  | 0  | 0  | 0  | 1  | 1  | 0  | 1  | 1  | 0  | 1  | 1  | 0  | 1  | 1  | 0  | 1  | 0  | 0  | 1  | 0 | 1 | 0 | 1 |   |   |   |
| 7    | 0 | 0 | 0 | 0 | 0 | 0 | 0 | 0 | 0 | 0 | 0  | 0  | 0  | 0  | 0  | 0  | 0  | 0  | 0  | 0  | 0  | 0  | 0  | 0  | 0  | 0  | 0  | 0  | 0  | 0  | 0  | 0  | 0 | 0 | 0 | 0 | 0 | 1 |   |
| 8    | 0 | 0 | 0 | 0 | 0 | 0 | 0 | 0 | 0 | 0 | 0  | 0  | 0  | 0  | 0  | 0  | 1  | 1  | 0  | 1  | 1  | 0  | 1  | 1  | 0  | 1  | 1  | 0  | 1  | 0  | 0  | 1  | 0 | 1 | 0 | 1 |   |   |   |
| 9    | 0 | 0 | 0 | 0 | 0 | 0 | 0 | 0 | 1 | 0 | 0  | 0  | 1  | 1  | 1  | 1  | 0  | 1  | 1  | 0  | 1  | 1  | 0  | 0  | 0  | 1  | 1  | 0  | 1  | 1  | 1  | 1  | 1 | 1 | 1 | 1 |   |   |   |
|      | 0 | 0 | 1 | 0 | 0 | 1 | 1 | 1 | 0 | 0 | 1  | 1  | 1  | 0  | 0  | 1  | 0  | 0  | 1  | 0  | 0  | 1  | 1  | 0  | 0  | 1  | 1  | 0  | 0  | 0  | 1  | 1  | 1 | 1 | 1 | 1 |   |   |   |
|      | 0 | 0 | 0 | 1 | 0 | 0 | 0 | 1 | 1 | 1 | 1  | 0  | 0  | 0  | 1  | 1  | 1  | 0  | 1  | 1  | 0  | 0  | 0  | 0  | 0  | 0  | 0  | 0  | 0  | 0  | 1  | 0  | 0 | 1 | 0 | 0 | 1 |   |   |
|      | 1 | 0 | 0 | 0 | 0 | 1 | 0 | 0 | 1 | 0 | 0  | 0  | 1  | 1  | 1  | 1  | 0  | 1  | 1  | 0  | 1  | 0  | 0  | 1  | 1  | 1  | 1  | 0  | 0  | 0  | 1  | 1  | 1 | 0 | 0 | 0 | 1 | 1 |   |
| 10   | 0 | 1 | 1 | 0 | 1 | 1 | 0 | 1 | 1 | 1 | 0  | 1  | 0  | 0  | 1  | 0  | 1  | 0  | 1  | 1  | 0  | 1  | 1  | 0  | 0  | 0  | 1  | 1  | 0  | 1  | 1  | 1  | 1 | 1 | 1 | 1 | 1 |   |   |
|      | 0 | 0 | 1 | 0 | 1 | 0 | 1 | 0 | 1 | 0 | 1  | 0  | 1  | 0  | 1  | 0  | 0  | 1  | 0  | 0  | 1  | 1  | 0  | 0  | 0  | 0  | 0  | 0  | 0  | 0  | 1  | 1  | 1 | 1 | 1 | 1 | 1 |   |   |
|      | 0 | 0 | 0 | 1 | 0 | 0 | 0 | 1 | 1 | 1 | 1  | 0  | 0  | 0  | 1  | 1  | 1  | 0  | 1  | 1  | 0  | 0  | 0  | 0  | 0  | 0  | 0  | 0  | 0  | 0  | 0  | 1  | 0 | 0 | 1 | 0 | 0 | 1 |   |
|      | 1 | 0 | 0 | 0 | 0 | 1 | 0 | 0 | 1 | 0 | 0  | 0  | 1  | 1  | 1  | 1  | 0  | 1  | 1  | 0  | 1  | 0  | 0  | 1  | 1  | 1  | 1  | 0  | 0  | 0  | 1  | 1  | 1 | 1 | 0 | 0 | 0 | 1 | 1 |
| 11   | 0 | 1 | 1 | 0 | 1 | 1 | 0 | 1 | 1 | 1 | 0  | 1  | 0  | 0  | 1  | 0  | 0  | 1  | 0  | 0  | 0  | 0  | 0  | 1  | 0  | 1  | 0  | 1  | 0  | 0  | 0  | 0  | 0 | 0 | 0 | 0 | 0 | 0 |   |

| Byte | 0 |   |   |   |   |   |   |   | 1 |   |    |    |    |    |    |    | 2  |    |    |    |    |    |    |    | 3  |    |    |    |    |    |    |    |   |
|------|---|---|---|---|---|---|---|---|---|---|----|----|----|----|----|----|----|----|----|----|----|----|----|----|----|----|----|----|----|----|----|----|---|
| Bit  | 0 | 1 | 2 | 3 | 4 | 5 | 6 | 7 | 8 | 9 | 10 | 11 | 12 | 13 | 14 | 15 | 16 | 17 | 18 | 19 | 20 | 21 | 22 | 23 | 24 | 25 | 26 | 27 | 28 | 29 | 30 | 31 |   |
|      | 0 | 1 | 0 | 1 | 0 | 0 | 0 | 0 | 0 | 0 | 1  | 0  | 1  | 1  | 0  | 1  | 0  | 1  | 0  | 0  | 0  | 1  | 0  | 0  | 0  | 1  | 0  | 0  | 0  | 1  | 0  | 1  |   |
|      | 0 | 1 | 0 | 1 | 0 | 1 | 0 | 0 | 0 | 1 | 0  | 0  | 0  | 1  | 0  | 1  | 0  | 1  | 0  | 0  | 0  | 0  | 1  | 1  | 0  | 1  | 0  | 1  | 0  | 1  | 0  | 0  |   |
|      | 0 | 0 | 1 | 0 | 0 | 0 | 0 | 0 | 0 | 1 | 0  | 0  | 0  | 1  | 0  | 0  | 0  | 1  | 0  | 0  | 1  | 1  | 1  | 0  | 0  | 1  | 0  | 1  | 0  | 0  | 1  | 1  |   |
|      | 0 | 0 | 1 | 0 | 0 | 0 | 0 | 0 | 0 | 1 | 1  | 1  | 0  | 0  | 1  | 0  | 0  | 1  | 1  | 0  | 0  | 1  | 0  | 1  | 0  | 1  | 1  | 1  | 0  | 0  | 0  | 1  |   |
|      | 0 | 1 | 1 | 1 | 0 | 1 | 0 | 1 | 0 | 1 | 1  | 0  | 0  | 1  | 0  | 1  | 0  | 1  | 1  | 1  | 0  | 0  | 1  | 1  | 0  | 1  | 1  | 1  | 0  | 1  | 0  | 0  |   |
|      | 0 | 0 | 1 | 0 | 0 | 0 | 0 | 0 | 0 | 1 | 1  | 0  | 0  | 1  | 1  | 0  | 0  | 1  | 1  | 0  | 1  | 1  | 1  | 1  | 0  | 1  | 1  | 1  | 0  | 0  | 1  | 0  |   |
|      | 0 | 0 | 1 | 0 | 0 | 0 | 0 | 0 | 0 | 1 | 1  | 1  | 0  | 0  | 0  | 0  | 0  | 1  | 1  | 0  | 1  | 1  | 1  | 1  | 0  | 1  | 1  | 1  | 0  | 1  | 0  | 0  |   |
|      | 0 | 1 | 1 | 0 | 0 | 1 | 0 | 1 | 0 | 1 | 1  | 0  | 1  | 1  | 1  | 0  | 0  | 1  | 1  | 1  | 0  | 1  | 0  | 0  | 0  | 1  | 1  | 0  | 1  | 0  | 0  | 1  |   |
|      | 0 | 1 | 1 | 0 | 0 | 0 | 0 | 0 | 1 | 0 | 1  | 1  | 0  | 1  | 1  | 0  | 0  | 0  | 0  | 1  | 0  | 0  | 0  | 0  | 0  | 1  | 1  | 0  | 1  | 1  | 0  | 1  |   |
|      | 0 | 1 | 1 | 0 | 0 | 0 | 0 | 1 | 0 | 1 | 1  | 0  | 1  | 1  | 0  | 0  | 0  | 1  | 1  | 1  | 0  | 1  | 1  | 0  | 1  | 1  | 1  | 0  | 1  | 1  | 0  | 0  | 0 |
|      | 0 | 1 | 1 | 1 | 0 | 0 | 1 | 0 | 0 | 1 | 1  | 0  | 0  | 1  | 0  | 1  | 0  | 0  | 0  | 1  | 0  | 1  | 1  | 1  | 0  | 0  | 1  | 0  | 0  | 1  | 0  | 0  | 0 |
|      | 0 | 0 | 1 | 0 | 0 | 0 | 0 | 0 | 0 | 1 | 1  | 1  | 0  | 1  | 0  | 0  | 0  | 1  | 1  | 0  | 0  | 1  | 1  | 1  | 0  | 0  | 1  | 0  | 0  | 0  | 0  | 0  | 0 |
|      | 0 | 1 | 1 | 0 | 0 | 1 | 0 | 0 | 0 | 1 | 1  | 0  | 1  | 1  | 1  | 1  | 0  | 1  | 1  | 0  | 1  | 1  | 0  | 1  | 0  | 1  | 1  | 0  | 0  | 0  | 0  | 1  | 1 |
|      | 0 | 1 | 1 | 0 | 1 | 0 | 0 | 1 | 0 | 1 | 1  | 0  | 1  | 1  | 1  | 0  | 0  | 0  | 1  | 0  | 0  | 0  | 0  | 0  | 0  | 0  | 0  | 1  | 1  | 0  | 0  | 1  | 1 |
|      | 0 | 0 | 1 | 1 | 0 | 1 | 1 | 0 | 0 | 0 | 1  | 1  | 0  | 0  | 0  | 0  | 0  | 0  | 1  | 0  | 1  | 1  | 1  | 0  | 0  | 1  | 1  | 0  | 0  | 0  | 1  | 1  | 1 |
|      | 0 | 1 | 1 | 0 | 1 | 1 | 1 | 0 |   |   |    |    |    |    |    |    |    |    |    |    |    |    |    |    |    |    |    |    |    |    |    |    |   |

In the preceding example, the following event information appears:

| Number | Description                                                                                                                                                              |
|--------|--------------------------------------------------------------------------------------------------------------------------------------------------------------------------|
| 1      | The first two bytes of this line indicate the standard header value of 1. The second two bytes indicate that the message is a data message (that is, message type four). |
| 2      | This line indicates that the message that follows is 129 bytes.                                                                                                          |
| 3      | This line indicates a record type value of 66, which represents a rule message record.                                                                                   |
| 4      | This line indicates that the rule message record that follows is 121 bytes long.                                                                                         |
| 5      | This line indicates that the generator identification number is 1, the rules engine.                                                                                     |
| 6      | This line indicates that the rule identification number is 28069.                                                                                                        |

| Number | Description                                                                                                                                                                                                                                                                                   |
|--------|-----------------------------------------------------------------------------------------------------------------------------------------------------------------------------------------------------------------------------------------------------------------------------------------------|
| 7      | This line indicates that the rule revision number is 1.                                                                                                                                                                                                                                       |
| 8      | This line indicates that the rule identification number rendered to the FireSIGHT System is 28069.                                                                                                                                                                                            |
| 9      | The first two bytes of this line indicate that there are 71 bytes included in the rule text name. The second two bytes begin the unique identifier number for the rule.                                                                                                                       |
| 10     | The first two bytes of this line finish the unique identifier number of the rule. The next two bytes begin the unique identifier number for the revision of the rule.                                                                                                                         |
| 11     | The first two bytes of this line finish the unique identifier number for the revision of the rule. The second two bytes begin the text of the rule message itself. The full text of the transmitted rule message is: APP-DETECT DNS request for potential malware SafeGuard to domain 360.cn. |

## Example of a Version 5.1+ User Event

The following diagram shows an example user event record:

| Byte | 0 |   |   |   |   |   |   |   | 1 |   |    |    |    |    |    |    | 2  |    |    |    |    |    |    |    | 3  |    |    |    |    |    |    |    |   |   |   |   |   |   |   |   |
|------|---|---|---|---|---|---|---|---|---|---|----|----|----|----|----|----|----|----|----|----|----|----|----|----|----|----|----|----|----|----|----|----|---|---|---|---|---|---|---|---|
|      | 0 | 1 | 2 | 3 | 4 | 5 | 6 | 7 | 8 | 9 | 10 | 11 | 12 | 13 | 14 | 15 | 16 | 17 | 18 | 19 | 20 | 21 | 22 | 23 | 24 | 25 | 26 | 27 | 28 | 29 | 30 | 31 |   |   |   |   |   |   |   |   |
| 1    | 0 | 0 | 0 | 0 | 0 | 0 | 0 | 0 | 0 | 0 | 0  | 0  | 0  | 0  | 0  | 1  | 0  | 0  | 0  | 0  | 0  | 0  | 0  | 0  | 0  | 0  | 0  | 0  | 0  | 0  | 0  | 1  | 0 | 0 |   |   |   |   |   |   |
| 2    | 0 | 0 | 0 | 0 | 0 | 0 | 0 | 0 | 0 | 0 | 0  | 0  | 0  | 0  | 0  | 0  | 0  | 0  | 0  | 0  | 0  | 0  | 0  | 0  | 0  | 0  | 0  | 0  | 0  | 0  | 1  | 0  | 0 | 1 | 1 | 0 | 0 | 1 |   |   |
| 3    | 0 | 0 | 0 | 0 | 0 | 0 | 0 | 0 | 0 | 0 | 0  | 0  | 0  | 0  | 0  | 0  | 0  | 0  | 0  | 0  | 0  | 0  | 0  | 0  | 0  | 0  | 0  | 0  | 0  | 0  | 1  | 0  | 1 | 1 | 1 | 1 | 1 | 1 |   |   |
| 4    | 0 | 0 | 0 | 0 | 0 | 0 | 0 | 0 | 0 | 0 | 0  | 0  | 0  | 0  | 0  | 0  | 0  | 0  | 0  | 0  | 0  | 0  | 0  | 0  | 0  | 0  | 0  | 0  | 0  | 0  | 1  | 0  | 0 | 0 | 1 | 0 | 0 | 1 |   |   |
| 5    | 0 | 1 | 0 | 1 | 0 | 0 | 1 | 1 | 0 | 0 | 1  | 1  | 0  | 0  | 0  | 0  | 0  | 1  | 1  | 1  | 1  | 1  | 0  | 0  | 0  | 0  | 1  | 0  | 1  | 0  | 1  | 0  | 0 | 1 | 0 | 0 | 1 |   |   |   |
| 6    | 0 | 0 | 0 | 0 | 0 | 0 | 0 | 0 | 0 | 0 | 0  | 0  | 0  | 0  | 0  | 0  | 0  | 0  | 0  | 0  | 0  | 0  | 0  | 0  | 0  | 0  | 0  | 0  | 0  | 0  | 0  | 0  | 0 | 0 | 0 | 0 | 0 | 0 |   |   |
| 7    | 0 | 0 | 0 | 0 | 0 | 0 | 0 | 0 | 0 | 0 | 0  | 0  | 0  | 0  | 0  | 0  | 0  | 0  | 0  | 0  | 0  | 0  | 0  | 0  | 0  | 0  | 0  | 0  | 0  | 0  | 0  | 0  | 0 | 0 | 0 | 0 | 0 | 1 | 1 |   |
| 8    | 0 | 0 | 0 | 0 | 0 | 0 | 0 | 0 | 0 | 0 | 0  | 0  | 0  | 0  | 0  | 0  | 0  | 0  | 0  | 0  | 0  | 0  | 0  | 0  | 0  | 0  | 0  | 0  | 0  | 0  | 0  | 0  | 0 | 0 | 0 | 0 | 0 | 0 | 0 |   |
| 9    | 0 | 0 | 0 | 0 | 0 | 0 | 0 | 0 | 0 | 0 | 0  | 0  | 0  | 0  | 0  | 0  | 0  | 0  | 0  | 0  | 0  | 0  | 0  | 0  | 0  | 0  | 0  | 0  | 0  | 0  | 0  | 0  | 0 | 0 | 0 | 0 | 0 | 0 | 0 |   |
| 10   | 0 | 0 | 0 | 0 | 0 | 0 | 0 | 0 | 0 | 0 | 0  | 0  | 0  | 0  | 0  | 0  | 0  | 0  | 0  | 0  | 0  | 0  | 0  | 0  | 0  | 0  | 0  | 0  | 0  | 0  | 0  | 0  | 0 | 0 | 0 | 0 | 0 | 0 | 0 |   |
| 11   | 0 | 1 | 0 | 1 | 0 | 0 | 1 | 0 | 1 | 1 | 1  | 0  | 1  | 1  | 1  | 1  | 1  | 1  | 1  | 1  | 1  | 1  | 0  | 0  | 0  | 1  | 0  | 1  | 1  | 1  | 0  | 0  | 1 | 1 | 0 | 0 | 1 | 1 |   |   |
| 12   | 0 | 0 | 0 | 0 | 0 | 0 | 0 | 0 | 0 | 0 | 0  | 0  | 0  | 0  | 0  | 0  | 1  | 1  | 1  | 0  | 0  | 0  | 1  | 1  | 0  | 0  | 1  | 0  | 0  | 1  | 0  | 0  | 1 | 1 | 1 | 1 | 1 | 1 |   |   |
| 13   | 0 | 0 | 0 | 0 | 0 | 0 | 0 | 0 | 0 | 0 | 0  | 0  | 0  | 0  | 0  | 0  | 0  | 0  | 0  | 0  | 0  | 0  | 0  | 0  | 0  | 0  | 1  | 1  | 1  | 1  | 1  | 0  | 1 | 1 | 0 | 0 | 0 | 0 |   |   |
| 14   | 0 | 0 | 0 | 0 | 0 | 0 | 0 | 0 | 0 | 0 | 0  | 0  | 0  | 0  | 0  | 0  | 0  | 0  | 0  | 0  | 0  | 0  | 0  | 0  | 0  | 0  | 0  | 0  | 0  | 0  | 0  | 0  | 0 | 0 | 0 | 0 | 0 | 0 | 1 | 0 |

| Byte | 0 |   |   |   |   |   |   | 1 |   |   |    |    |    |    | 2  |    |    |    |    |    |    | 3  |    |    |    |    |    |    |    |    |    |    |
|------|---|---|---|---|---|---|---|---|---|---|----|----|----|----|----|----|----|----|----|----|----|----|----|----|----|----|----|----|----|----|----|----|
|      | 0 | 1 | 2 | 3 | 4 | 5 | 6 | 7 | 8 | 9 | 10 | 11 | 12 | 13 | 14 | 15 | 16 | 17 | 18 | 19 | 20 | 21 | 22 | 23 | 24 | 25 | 26 | 27 | 28 | 29 | 30 | 31 |
| 15   | 0 | 1 | 1 | 1 | 0 | 0 | 1 | 1 | 1 | 1 | 1  | 1  | 0  | 0  | 0  | 1  | 1  | 1  | 1  | 0  | 1  | 1  | 1  | 1  | 0  | 1  | 0  | 1  | 0  | 0  | 1  | 0  |
| 16   | 0 | 0 | 0 | 1 | 0 | 0 | 0 | 1 | 0 | 0 | 0  | 0  | 0  | 0  | 0  | 1  | 0  | 0  | 0  | 0  | 0  | 0  | 0  | 0  | 0  | 0  | 0  | 0  | 0  | 0  | 0  | 0  |
| 17   | 0 | 0 | 0 | 0 | 0 | 0 | 0 | 0 | 0 | 0 | 0  | 0  | 0  | 0  | 0  | 0  | 0  | 0  | 0  | 0  | 0  | 0  | 0  | 0  | 0  | 0  | 0  | 0  | 0  | 0  | 0  |    |
|      | 0 | 0 | 0 | 0 | 0 | 0 | 0 | 0 | 0 | 0 | 0  | 0  | 0  | 0  | 0  | 0  | 0  | 0  | 0  | 0  | 0  | 0  | 0  | 0  | 0  | 0  | 0  | 0  | 0  | 0  | 0  |    |
|      | 0 | 0 | 0 | 0 | 0 | 0 | 0 | 0 | 0 | 0 | 0  | 0  | 0  | 0  | 0  | 1  | 1  | 1  | 1  | 1  | 1  | 1  | 1  | 1  | 1  | 1  | 1  | 1  | 1  | 1  | 1  |    |
|      | 0 | 0 | 0 | 0 | 1 | 0 | 1 | 0 | 0 | 0 | 0  | 0  | 0  | 1  | 0  | 0  | 0  | 0  | 0  | 0  | 0  | 1  | 1  | 1  | 1  | 0  | 1  | 1  | 1  | 0  | 0  |    |
| 18   | 0 | 0 | 0 | 0 | 0 | 0 | 0 | 0 | 0 | 0 | 0  | 0  | 0  | 0  | 0  | 0  | 0  | 0  | 0  | 0  | 0  | 0  | 0  | 0  | 0  | 0  | 1  | 1  | 1  | 1  | 1  |    |
| 19   | 0 | 0 | 0 | 0 | 0 | 0 | 0 | 0 | 0 | 0 | 0  | 0  | 0  | 0  | 0  | 0  | 0  | 0  | 0  | 0  | 0  | 0  | 0  | 0  | 0  | 0  | 1  | 0  | 1  | 0  | 0  |    |
| 20   | 0 | 1 | 0 | 1 | 0 | 0 | 1 | 0 | 1 | 1 | 1  | 0  | 1  | 1  | 1  | 1  | 1  | 1  | 1  | 1  | 1  | 0  | 0  | 0  | 1  | 0  | 1  | 1  | 1  | 0  | 0  |    |
| 21   | 0 | 0 | 0 | 0 | 0 | 0 | 0 | 0 | 0 | 0 | 0  | 0  | 0  | 0  | 0  | 0  | 0  | 0  | 0  | 0  | 0  | 0  | 0  | 0  | 0  | 0  | 0  | 0  | 0  | 0  | 0  |    |
| 22   | 0 | 0 | 0 | 0 | 0 | 0 | 0 | 0 | 0 | 0 | 0  | 0  | 0  | 0  | 0  | 0  | 0  | 0  | 0  | 0  | 0  | 0  | 0  | 0  | 0  | 0  | 0  | 0  | 0  | 0  | 0  |    |
| 23   | 0 | 0 | 0 | 0 | 0 | 0 | 0 | 0 | 0 | 0 | 0  | 0  | 0  | 0  | 0  | 0  | 0  | 0  | 0  | 0  | 0  | 0  | 0  | 0  | 0  | 0  | 0  | 0  | 0  | 0  | 0  |    |
| 24   | 0 | 0 | 1 | 0 | 0 | 0 | 0 | 0 | 0 | 0 | 1  | 1  | 0  | 0  | 1  | 1  | 0  | 0  | 1  | 1  | 0  | 0  | 0  | 0  | 0  | 0  | 1  | 1  | 0  | 0  | 0  |    |
|      | 0 | 1 | 0 | 0 | 0 | 0 | 0 | 0 | 0 | 0 | 1  | 1  | 0  | 0  | 0  | 1  | 0  | 0  | 1  | 1  | 0  | 0  | 0  | 0  | 0  | 0  | 1  | 0  | 1  | 1  | 1  |    |
|      | 0 | 0 | 1 | 1 | 0 | 1 | 0 | 0 | 0 | 0 | 1  | 0  | 1  | 1  | 1  | 0  | 0  | 0  | 1  | 1  | 0  | 0  | 0  | 1  | 0  | 0  | 1  | 1  | 0  | 0  | 0  |    |
|      | 0 | 0 | 1 | 0 | 1 | 1 | 1 | 0 | 0 | 0 | 1  | 1  | 0  | 0  | 0  | 1  | 0  | 0  | 1  | 1  | 0  | 1  | 1  | 1  | 0  | 0  | 1  | 1  | 0  | 1  | 0  |    |
| 25   | 0 | 0 | 0 | 0 | 0 | 0 | 0 | 0 | 0 | 0 | 0  | 0  | 0  | 0  | 0  | 0  | 0  | 0  | 0  | 0  | 0  | 0  | 0  | 0  | 0  | 0  | 0  | 0  | 0  | 0  | 0  |    |
| 26   | 0 | 0 | 0 | 0 | 0 | 0 | 0 | 0 | 0 | 0 | 0  | 0  | 0  | 0  | 0  | 0  | 0  | 0  | 0  | 0  | 0  | 0  | 0  | 0  | 0  | 0  | 1  | 1  | 0  | 1  | 0  |    |
| 27   | 0 | 0 | 0 | 0 | 0 | 0 | 0 | 0 | 0 | 0 | 0  | 0  | 0  | 0  | 0  | 0  | 0  | 0  | 0  | 0  | 0  | 0  | 0  | 0  | 0  | 0  | 0  | 0  | 0  | 0  | 0  |    |
| 28   | 0 | 0 | 0 | 0 | 0 | 0 | 0 | 0 | 0 | 0 | 0  | 0  | 0  | 0  | 0  | 0  | 0  | 0  | 0  | 0  | 0  | 0  | 0  | 0  | 0  | 0  | 0  | 0  | 0  | 0  | 0  |    |
| 29   | 0 | 0 | 0 | 0 | 0 | 0 | 0 | 0 | 0 | 0 | 0  | 0  | 0  | 0  | 0  | 0  | 0  | 0  | 0  | 0  | 0  | 0  | 0  | 0  | 0  | 0  | 0  | 0  | 0  | 0  | 0  |    |
|      | 0 | 0 | 0 | 0 | 0 | 0 | 0 | 0 | 0 | 0 | 0  | 0  | 0  | 0  | 0  | 0  | 0  | 0  | 0  | 0  | 0  | 0  | 0  | 0  | 0  | 0  | 0  | 0  | 0  | 0  | 0  |    |
|      | 0 | 0 | 0 | 0 | 0 | 0 | 0 | 0 | 0 | 0 | 0  | 0  | 0  | 0  | 0  | 1  | 1  | 1  | 1  | 1  | 1  | 1  | 1  | 1  | 1  | 1  | 1  | 1  | 1  | 1  | 1  |    |
|      | 0 | 0 | 0 | 0 | 1 | 0 | 1 | 0 | 0 | 0 | 0  | 0  | 0  | 1  | 0  | 0  | 0  | 0  | 0  | 0  | 0  | 0  | 0  | 0  | 1  | 1  | 1  | 1  | 0  | 0  | 0  |    |
| 30   | 0 | 0 | 0 | 0 | 0 | 0 | 0 | 0 | 0 | 0 | 0  | 0  | 0  | 0  | 0  | 0  | 0  | 0  | 0  | 0  | 0  | 0  | 0  | 0  | 0  | 0  | 0  | 0  | 0  | 0  | 0  |    |



|      |   |   |   |   |   |   |   |   |   |   |    |    |    |    |    |    |    |    |    |    |    |    |    |    |    |    |    |    |    |    |    |    |  |  |  |  |  |
|------|---|---|---|---|---|---|---|---|---|---|----|----|----|----|----|----|----|----|----|----|----|----|----|----|----|----|----|----|----|----|----|----|--|--|--|--|--|
| Byte | 0 |   |   |   |   |   |   |   | 1 |   |    |    |    |    |    |    | 2  |    |    |    |    |    |    |    | 3  |    |    |    |    |    |    |    |  |  |  |  |  |
| Bit  | 0 | 1 | 2 | 3 | 4 | 5 | 6 | 7 | 8 | 9 | 10 | 11 | 12 | 13 | 14 | 15 | 16 | 17 | 18 | 19 | 20 | 21 | 22 | 23 | 24 | 25 | 26 | 27 | 28 | 29 | 30 | 31 |  |  |  |  |  |
| 31   | 0 | 0 | 0 | 0 | 0 | 0 | 0 | 0 | 0 | 0 | 0  | 0  | 0  | 0  | 0  | 0  | 0  | 0  | 0  | 0  | 0  | 0  | 0  | 0  | 0  | 0  | 0  | 0  | 0  | 0  | 0  | 0  |  |  |  |  |  |
|      | 0 | 0 | 0 | 0 | 0 | 0 | 0 | 0 |   |   |    |    |    |    |    |    |    |    |    |    |    |    |    |    |    |    |    |    |    |    |    |    |  |  |  |  |  |

In the preceding example, the following information appears:

| Number | Description                                                                                                                                                                                                             |
|--------|-------------------------------------------------------------------------------------------------------------------------------------------------------------------------------------------------------------------------|
| 1      | The first two bytes of this line indicate the standard header value of 1. The second two bytes indicate that the message is a data message (that is, message type four).                                                |
| 2      | This line indicates that the message that follows is 153 bytes long.                                                                                                                                                    |
| 3      | This line indicates a record type value of 95, which represents a user information update message block.                                                                                                                |
| 4      | This line indicates that the data that follows is 137 bytes long.                                                                                                                                                       |
| 5      | This line contains the archive timestamp. It is included since bit 23 was set. The timestamp is a Unix timestamp, stored as seconds since 1/1/1970. This time stamp is 1,391,789,354, which is Mon Feb 3 19:43:49 2014. |
| 6      | This line contains zeros and is reserved for future use.                                                                                                                                                                |
| 7      | This line indicates that the detection engine ID is 3.                                                                                                                                                                  |
| 8      | This line is for the legacy (IPv4) IP address. It contains all zeros as it is not populated and the IPv4 address is stored in the IPv6 field.                                                                           |
| 9      | This line contains the MAC address associated with the event. As there is no MAC address, it contains zeros.                                                                                                            |
| 10     | The first half of this line is the remainder of the MAC address, which is zeros. The next byte indicates the presence of an IPv6 address. The last byte in this line is reserved for future use and contains zeros.     |
| 11     | This line contains the UNIX timestamp (seconds since 01/01/1970) that the system generated the event.                                                                                                                   |
| 12     | This line contains the microsecond (one millionth of a second) increment that the system generated the event.                                                                                                           |
| 13     | This line contains the event type. This has a value of 1004, which indicates a user modification message.                                                                                                               |
| 14     | This line contains the event subtype. This has a value of 2, which indicates a user login event.                                                                                                                        |
| 15     | This line contains the serial file number. This field is for internal use and can be disregarded.                                                                                                                       |
| 16     | This line contains the event's position in the serial file. This field is for internal use and can be disregarded.                                                                                                      |
| 17     | This line contains the IPv6 address. This field is present and used if the Has IPv6 flag is set. In this case, however, it contains the IPv4 address 10.4.15.120.                                                       |
| 18     | This line initiates a User Login Information data block, indicated by block type 127.                                                                                                                                   |

| Number | Description                                                                                                                                                                                                                                                                                                                                        |
|--------|----------------------------------------------------------------------------------------------------------------------------------------------------------------------------------------------------------------------------------------------------------------------------------------------------------------------------------------------------|
| 19     | This line indicates that the block that follows is 81 bytes long.                                                                                                                                                                                                                                                                                  |
| 20     | This line indicates that the user login timestamp is 1,391,456,627, which means it was generated at Mon, 03 Oct 2014 19:43:47 GMT.                                                                                                                                                                                                                 |
| 21     | This line is for the legacy (IPv4) IP address. It contains all zeros as it is not populated and the IPv4 address is stored in the IPv6 field.                                                                                                                                                                                                      |
| 22     | This line indicates that a string block follows, containing a string block length and a text string which, in this case, contains the user name. For more information about string blocks, see <a href="#">String Data Block, page 3-48</a> .                                                                                                      |
| 23     | This line indicates that the length of the data in the string block is 16 bytes.                                                                                                                                                                                                                                                                   |
| 24     | This line indicates that the name of the user is "301@10.4.11.175."                                                                                                                                                                                                                                                                                |
| 25     | The line indicates the ID number of the user.                                                                                                                                                                                                                                                                                                      |
| 26     | This line indicates the application ID for the application protocol used in the connection that the login information was derived from.                                                                                                                                                                                                            |
| 27     | This line indicates that a string block follows, containing a string block length and a text string which, in this case, contains the email address. For more information about string blocks, see <a href="#">String Data Block, page 3-48</a> .                                                                                                  |
| 28     | This line indicates that the length of the data in the string block is 0 bytes. This is because there is no email address associated with this user.                                                                                                                                                                                               |
| 29     | This line contains IP address from the host where the user was detected logging in.                                                                                                                                                                                                                                                                |
| 30     | The first byte contains the login type. The remainder of this line indicates that a string block follows, containing a string block length and a text string which, in this case, contains the name of the Active Directory server reporting a login. For more information about string blocks, see <a href="#">String Data Block, page 3-48</a> . |
| 31     | The first byte of this line completes the initiation of the string data block. This remainder of this line indicates that the length of the data in the string block is 0 bytes. This is because there is no Active Directory server associated with this login.                                                                                   |

## Discovery Data Structure Examples

This section contains examples of data structures that can be transmitted by eStreamer for discovery events. The following examples are provided:

- [Example of a New Network Protocol Message, page A-17](#)
- [Example of a New TCP Server Message, page A-18](#)

# Example of a New Network Protocol Message

The following diagram illustrates a sample new network protocol message for 3.0+:

| Byte                      | 0                                                                           |   |   |   |   |   |   |   | 1                                                                   |   |    |    |    |    |    |    | 2                                   |    |    |    |    |    |    |    | 3  |    |    |    |    |    |    |    |                                                  |
|---------------------------|-----------------------------------------------------------------------------|---|---|---|---|---|---|---|---------------------------------------------------------------------|---|----|----|----|----|----|----|-------------------------------------|----|----|----|----|----|----|----|----|----|----|----|----|----|----|----|--------------------------------------------------|
|                           | 0                                                                           | 1 | 2 | 3 | 4 | 5 | 6 | 7 | 8                                                                   | 9 | 10 | 11 | 12 | 13 | 14 | 15 | 16                                  | 17 | 18 | 19 | 20 | 21 | 22 | 23 | 24 | 25 | 26 | 27 | 28 | 29 | 30 | 31 |                                                  |
| Header Version 1          | 0 0 0 0 0 0 0 0 0 0 0 0 0 0 0 1                                             |   |   |   |   |   |   |   |                                                                     |   |    |    |    |    |    |    | 0 0 0 0 0 0 0 0 0 0 0 0 0 0 0 1 0 0 |    |    |    |    |    |    |    |    |    |    |    |    |    |    |    | Start Standard Message Header with Event Msg (4) |
| Message Length (49B)      | 0 0 0 0 0 0 0 0 0 0 0 0 0 0 0 0 0 0 0 0 0 0 0 0 0 0 0 0 0 0 0 1 1 0 0 0 1   |   |   |   |   |   |   |   |                                                                     |   |    |    |    |    |    |    |                                     |    |    |    |    |    |    |    |    |    |    |    |    |    |    |    |                                                  |
| New NW Protocol Msg (13)  | 0 0 0 0 0 0 0 0 0 0 0 0 0 0 0 0 0 0 0 0 0 0 0 0 0 0 0 0 0 0 0 0 1 1 0 1     |   |   |   |   |   |   |   |                                                                     |   |    |    |    |    |    |    |                                     |    |    |    |    |    |    |    |    |    |    |    |    |    |    |    |                                                  |
| Msg Length (41B)          | 0 0 0 0 0 0 0 0 0 0 0 0 0 0 0 0 0 0 0 0 0 0 0 0 0 0 0 0 0 1 0 1 1 0 1 0 0 0 |   |   |   |   |   |   |   |                                                                     |   |    |    |    |    |    |    |                                     |    |    |    |    |    |    |    |    |    |    |    |    |    |    |    |                                                  |
| Detection Engine ID (2)   | 0 0 0 0 0 0 0 0 0 0 0 0 0 0 0 0 0 0 0 0 0 0 0 0 0 0 0 0 0 0 0 0 0 0 1 0     |   |   |   |   |   |   |   |                                                                     |   |    |    |    |    |    |    |                                     |    |    |    |    |    |    |    |    |    |    |    |    |    |    |    |                                                  |
| IP (192.168.1.10)         | 1 1 0 0 0 0 0 0 1 0 1 0 1 0 0 0 0 0 0 0 0 0 0 0 0 0 0 0 1 0 0 0 0 1 0 1 0   |   |   |   |   |   |   |   |                                                                     |   |    |    |    |    |    |    |                                     |    |    |    |    |    |    |    |    |    |    |    |    |    |    |    |                                                  |
| MAC Address (none)        | 0 0 0 0 0 0 0 0 0 0 0 0 0 0 0 0                                             |   |   |   |   |   |   |   |                                                                     |   |    |    |    |    |    |    | 0 0 0 0 0 0 0 0 0 0 0 0 0 0 0 0     |    |    |    |    |    |    |    |    |    |    |    |    |    |    |    | Reserved Bytes (0)                               |
| Unix Sec (1047242787)     | 0 0 1 1 1 1 1 0 0 1 1 0 1 0 1 1 1 0 1 0 1 0 0 0 0 0 1 0 0 0 1 1             |   |   |   |   |   |   |   |                                                                     |   |    |    |    |    |    |    |                                     |    |    |    |    |    |    |    |    |    |    |    |    |    |    |    |                                                  |
| Unix MSec (973208)        | 0 0 0 0 0 0 0 0 0 0 0 0 0 1 1 1 0 1 1 0 1 1 0 0 1 1 0 0 1 1 0 0 1 1 0 0 0   |   |   |   |   |   |   |   |                                                                     |   |    |    |    |    |    |    |                                     |    |    |    |    |    |    |    |    |    |    |    |    |    |    |    |                                                  |
| Reserved Bytes (0)        | 0 0 0 0 0 0 0 0                                                             |   |   |   |   |   |   |   | 0 0 0 0 0 0 0 0 0 0 0 0 0 0 0 0 0 0 0 0 0 0 0 0 1 1 1 1 1 0 1 0 0 0 |   |    |    |    |    |    |    |                                     |    |    |    |    |    |    |    |    |    |    |    |    |    |    |    | Event Type 1000—New                              |
| EventSub 4-New Trans Prot | 0 0 0 0 0 0 0 0 0 0 0 0 0 0 0 0 0 0 0 0 0 0 0 0 0 0 0 0 0 0 0 0 0 0 1 0 0   |   |   |   |   |   |   |   |                                                                     |   |    |    |    |    |    |    |                                     |    |    |    |    |    |    |    |    |    |    |    |    |    |    |    |                                                  |
| File Number               | 0 1 0 0 0 0 0 0 0 1 0 0 0 1 1 1 1 0 0 0 1 0 0 1 1 1 0 1 0 0 0 1             |   |   |   |   |   |   |   |                                                                     |   |    |    |    |    |    |    |                                     |    |    |    |    |    |    |    |    |    |    |    |    |    |    |    |                                                  |
| File Position             | 0 0 0 0 0 0 0 0 0 0 0 0 0 0 0 0 0 0 0 0 0 0 0 0 0 0 0 0 1 1 0 0 0 0 0 0     |   |   |   |   |   |   |   |                                                                     |   |    |    |    |    |    |    |                                     |    |    |    |    |    |    |    |    |    |    |    |    |    |    |    | End Standard Message Header                      |
| Protocol (6—TCP)          | 0 0 0 0 0 1 1 0                                                             |   |   |   |   |   |   |   |                                                                     |   |    |    |    |    |    |    |                                     |    |    |    |    |    |    |    |    |    |    |    |    |    |    |    |                                                  |

# Example of a New TCP Server Message

The following diagram illustrates a sample new TCP server message for 3.0:

| Byte                      | 0 |   |   |   |   |   |   |   | 1 |   |    |    |    |    |    |    | 2  |    |    |    |    |    |    |    | 3  |    |    |    |    |    |    |    |   |   |                                                  |   |   |   |                    |                             |                     |
|---------------------------|---|---|---|---|---|---|---|---|---|---|----|----|----|----|----|----|----|----|----|----|----|----|----|----|----|----|----|----|----|----|----|----|---|---|--------------------------------------------------|---|---|---|--------------------|-----------------------------|---------------------|
|                           | 0 | 1 | 2 | 3 | 4 | 5 | 6 | 7 | 8 | 9 | 10 | 11 | 12 | 13 | 14 | 15 | 16 | 17 | 18 | 19 | 20 | 21 | 22 | 23 | 24 | 25 | 26 | 27 | 28 | 29 | 30 | 31 |   |   |                                                  |   |   |   |                    |                             |                     |
| Header Version 1          | 0 | 0 | 0 | 0 | 0 | 0 | 0 | 0 | 0 | 0 | 0  | 0  | 0  | 0  | 0  | 1  | 0  | 0  | 0  | 0  | 0  | 0  | 0  | 0  | 0  | 0  | 0  | 0  | 0  | 0  | 0  | 1  | 0 | 0 | Start Standard Message Header with Event Msg (4) |   |   |   |                    |                             |                     |
| Message Length (256B)     | 0 | 0 | 0 | 0 | 0 | 0 | 0 | 0 | 0 | 0 | 0  | 0  | 0  | 0  | 0  | 0  | 0  | 0  | 0  | 0  | 0  | 0  | 0  | 0  | 0  | 0  | 0  | 0  | 0  | 0  | 0  | 0  | 0 | 0 |                                                  |   |   |   |                    |                             |                     |
| New TCP Svc Msg (11)      | 0 | 0 | 0 | 0 | 0 | 0 | 0 | 0 | 0 | 0 | 0  | 0  | 0  | 0  | 0  | 0  | 0  | 0  | 0  | 0  | 0  | 0  | 0  | 0  | 0  | 0  | 0  | 0  | 0  | 0  | 1  | 0  | 1 | 1 |                                                  |   |   |   |                    |                             |                     |
| Msg Length (248B)         | 0 | 0 | 0 | 0 | 0 | 0 | 0 | 0 | 0 | 0 | 0  | 0  | 0  | 0  | 0  | 0  | 0  | 0  | 0  | 0  | 0  | 0  | 0  | 0  | 0  | 0  | 0  | 0  | 0  | 0  | 1  | 1  | 1 | 1 |                                                  | 0 | 0 | 0 |                    |                             |                     |
| Detection Engine ID (2)   | 0 | 0 | 0 | 0 | 0 | 0 | 0 | 0 | 0 | 0 | 0  | 0  | 0  | 0  | 0  | 0  | 0  | 0  | 0  | 0  | 0  | 0  | 0  | 0  | 0  | 0  | 0  | 0  | 0  | 0  | 0  | 0  | 0 | 0 | 0                                                | 1 | 0 |   |                    |                             |                     |
| IP (192.168.1.10)         | 1 | 1 | 0 | 0 | 0 | 0 | 0 | 0 | 1 | 0 | 1  | 0  | 1  | 0  | 0  | 0  | 0  | 0  | 0  | 0  | 0  | 0  | 0  | 0  | 0  | 0  | 0  | 0  | 0  | 0  | 1  | 0  | 0 | 0 | 0                                                | 1 | 0 | 1 | 0                  |                             |                     |
| MAC Address (none)        | 0 | 0 | 0 | 0 | 0 | 0 | 0 | 0 | 0 | 0 | 0  | 0  | 0  | 0  | 0  | 0  | 0  | 0  | 0  | 0  | 0  | 0  | 0  | 0  | 0  | 0  | 0  | 0  | 0  | 0  | 0  | 0  | 0 | 0 | 0                                                | 0 | 0 | 0 | 0                  |                             |                     |
|                           | 0 | 0 | 0 | 0 | 0 | 0 | 0 | 0 | 0 | 0 | 0  | 0  | 0  | 0  | 0  | 0  | 0  | 0  | 0  | 0  | 0  | 0  | 0  | 0  | 0  | 0  | 0  | 0  | 0  | 0  | 0  | 0  | 0 | 0 | 0                                                | 0 | 0 | 0 | Reserved Bytes (0) |                             |                     |
| Unix Sec (1047242787)     | 0 | 0 | 1 | 1 | 1 | 1 | 1 | 0 | 0 | 1 | 1  | 0  | 1  | 0  | 1  | 1  | 1  | 0  | 1  | 0  | 1  | 0  | 0  | 0  | 0  | 0  | 0  | 1  | 0  | 0  | 0  | 1  | 1 |   |                                                  |   |   |   |                    |                             |                     |
| Unix MSec (973208)        | 0 | 0 | 0 | 0 | 0 | 0 | 0 | 0 | 0 | 0 | 0  | 0  | 1  | 1  | 1  | 0  | 1  | 1  | 0  | 1  | 1  | 0  | 0  | 1  | 1  | 0  | 0  | 1  | 1  | 0  | 0  | 1  | 1 | 0 | 0                                                | 0 | 0 |   |                    |                             |                     |
| Reserved Bytes (0)        | 0 | 0 | 0 | 0 | 0 | 0 | 0 | 0 | 0 | 0 | 0  | 0  | 0  | 0  | 0  | 0  | 0  | 0  | 0  | 0  | 0  | 0  | 0  | 0  | 0  | 0  | 0  | 0  | 0  | 0  | 1  | 1  | 1 | 1 | 1                                                | 0 | 1 | 0 | 0                  | 0                           | Event Type 1000—New |
| Event Subtype 2 -New Host | 0 | 0 | 0 | 0 | 0 | 0 | 0 | 0 | 0 | 0 | 0  | 0  | 0  | 0  | 0  | 0  | 0  | 0  | 0  | 0  | 0  | 0  | 0  | 0  | 0  | 0  | 0  | 0  | 0  | 0  | 0  | 0  | 0 | 0 | 0                                                | 0 | 0 | 0 | 1                  | 0                           |                     |
| File Number               | 0 | 1 | 0 | 0 | 0 | 0 | 0 | 0 | 0 | 1 | 0  | 0  | 0  | 1  | 1  | 1  | 1  | 0  | 0  | 0  | 1  | 0  | 0  | 1  | 1  | 1  | 0  | 1  | 0  | 0  | 0  | 1  | 1 | 0 | 1                                                | 0 | 0 | 0 | 1                  |                             |                     |
| File Position             | 0 | 0 | 0 | 0 | 0 | 0 | 0 | 0 | 0 | 0 | 0  | 0  | 0  | 0  | 0  | 0  | 0  | 0  | 0  | 0  | 0  | 0  | 0  | 0  | 0  | 0  | 0  | 0  | 0  | 0  | 1  | 1  | 0 | 0 | 0                                                | 0 | 0 | 0 | 0                  | End Standard Message Header |                     |
| Server Block Header (12)  | 0 | 0 | 0 | 0 | 0 | 0 | 0 | 0 | 0 | 0 | 0  | 0  | 0  | 0  | 0  | 0  | 0  | 0  | 0  | 0  | 0  | 0  | 0  | 0  | 0  | 0  | 0  | 0  | 0  | 0  | 0  | 0  | 0 | 0 | 0                                                | 1 | 1 | 0 | 0                  | Start Server Data Block     |                     |



Discovery Data Structure Examples

| Byte                                        | 0                                                                                                     |   |   |   |   |   |   |   | 1 |   |    |    |    |    |    |                                                                                                   | 2  |    |    |    |    |    |    |    | 3  |    |    |    |    |    |    |                        |  |
|---------------------------------------------|-------------------------------------------------------------------------------------------------------|---|---|---|---|---|---|---|---|---|----|----|----|----|----|---------------------------------------------------------------------------------------------------|----|----|----|----|----|----|----|----|----|----|----|----|----|----|----|------------------------|--|
|                                             | 0                                                                                                     | 1 | 2 | 3 | 4 | 5 | 6 | 7 | 8 | 9 | 10 | 11 | 12 | 13 | 14 | 15                                                                                                | 16 | 17 | 18 | 19 | 20 | 21 | 22 | 23 | 24 | 25 | 26 | 27 | 28 | 29 | 30 | 31                     |  |
| Sub-server Hdr (1)                          | 0 0 0 0 0 0 0 0 0 0 0 0 0 0 0 0 0 0 0 0 0 0 0 0 0 0 0 0 0 0 0 0 0 0 0 0 0 1                           |   |   |   |   |   |   |   |   |   |    |    |    |    |    |                                                                                                   |    |    |    |    |    |    |    |    |    |    |    |    |    |    |    | Start Sub-server Block |  |
| Sub-server Len (46B)                        | 0 0 0 0 0 0 0 0 0 0 0 0 0 0 0 0 0 0 0 0 0 0 0 0 0 0 0 0 0 0 0 0 0 0 0 0 0 0 1 0 1 1 1 0               |   |   |   |   |   |   |   |   |   |    |    |    |    |    |                                                                                                   |    |    |    |    |    |    |    |    |    |    |    |    |    |    |    |                        |  |
| String Block Header (0)                     | 0 0 0 0 0 0 0 0 0 0 0 0 0 0 0 0 0 0 0 0 0 0 0 0 0 0 0 0 0 0 0 0 0 0 0 0 0 0 0 0 0 0                   |   |   |   |   |   |   |   |   |   |    |    |    |    |    |                                                                                                   |    |    |    |    |    |    |    |    |    |    |    |    |    |    |    |                        |  |
| String Length (16B)                         | 0 0 0 0 0 0 0 0 0 0 0 0 0 0 0 0 0 0 0 0 0 0 0 0 0 0 0 0 0 0 0 0 0 0 0 0 0 0 1 0 0 0 0                 |   |   |   |   |   |   |   |   |   |    |    |    |    |    |                                                                                                   |    |    |    |    |    |    |    |    |    |    |    |    |    |    |    |                        |  |
| Sub-server Name - mod_ssl                   | 0 1 1 0 1 1 0 1 0 1 1 0 1 1 1 1 0 1 1 0 0 1 0 0 0 1 0 0 0 1 0 1 1 1 1 1 1 0 1 1 1 1 1 1 1 1 1 1 1     |   |   |   |   |   |   |   |   |   |    |    |    |    |    |                                                                                                   |    |    |    |    |    |    |    |    |    |    |    |    |    |    |    |                        |  |
| String Block Header (0)                     | 0 1 1 1 0 0 1 1 0 1 1 1 0 0 1 1 0 1 1 0 1 1 0 0 0 0 0 0 0 0 0 0 0 0 0 0 0 0 0 0 0 0 0 0 0 0 0 0 0     |   |   |   |   |   |   |   |   |   |    |    |    |    |    |                                                                                                   |    |    |    |    |    |    |    |    |    |    |    |    |    |    |    |                        |  |
| String Block Header (0)                     | 0 0 0 0 0 0 0 0 0 0 0 0 0 0 0 0 0 0 0 0 0 0 0 0 0 0 0 0 0 0 0 0 0 0 0 0 0 0 0 0 0 0 0 0 0 0 0 0 0     |   |   |   |   |   |   |   |   |   |    |    |    |    |    |                                                                                                   |    |    |    |    |    |    |    |    |    |    |    |    |    |    |    |                        |  |
| String Block Len (8B)                       | 0 0 0 0 0 0 0 0 0 0 0 0 0 0 0 0 0 0 0 0 0 0 0 0 0 0 0 0 0 0 0 0 0 0 0 0 0 0 0 0 0 0 0 1 0 0 0 0       |   |   |   |   |   |   |   |   |   |    |    |    |    |    |                                                                                                   |    |    |    |    |    |    |    |    |    |    |    |    |    |    |    | (No subtype vendor)    |  |
| String Block Header (0)                     | 0 0 0 0 0 0 0 0 0 0 0 0 0 0 0 0 0 0 0 0 0 0 0 0 0 0 0 0 0 0 0 0 0 0 0 0 0 0 0 0 0 0 0 0 0 0 0 0 0     |   |   |   |   |   |   |   |   |   |    |    |    |    |    |                                                                                                   |    |    |    |    |    |    |    |    |    |    |    |    |    |    |    |                        |  |
| String Block Length (14B)                   | 0 0 0 0 0 0 0 0 0 0 0 0 0 0 0 0 0 0 0 0 0 0 0 0 0 0 0 0 0 0 0 0 0 0 0 0 0 0 0 0 0 0 0 1 1 1 0 0       |   |   |   |   |   |   |   |   |   |    |    |    |    |    |                                                                                                   |    |    |    |    |    |    |    |    |    |    |    |    |    |    |    |                        |  |
| Sub-server Version - 2.8.9 + null character | 0 0 1 1 0 0 1 0 0 0 1 0 1 1 1 0 0 0 1 1 1 0 0 0 0 0 0 1 0 1 1 1 1 0 0 0 0 0 0 0 0 0 0 0 1 0 1 1 1 1 0 |   |   |   |   |   |   |   |   |   |    |    |    |    |    |                                                                                                   |    |    |    |    |    |    |    |    |    |    |    |    |    |    |    | End Sub-server Block   |  |
|                                             | 0 0 1 1 1 0 0 1 0 0 0 0 0 0 0 0 0 0                                                                   |   |   |   |   |   |   |   |   |   |    |    |    |    |    | 0 0 0 0 0 0 0 0 0 0 0 0 0 0 0 0 0 0 0 0 0 0 0 0 0 0 0 0 0 0 0 0 0 0 0 0 0 0 0 0 0 0 0 0 0 0 0 0 0 |    |    |    |    |    |    |    |    |    |    |    |    |    |    |    | Start Sub-server Block |  |
| Sub-server Hdr (1)                          | 0 0 0 0 0 0 0 0 0 0 0 0 0 0 0 0 1                                                                     |   |   |   |   |   |   |   |   |   |    |    |    |    |    | 0 0 0 0 0 0 0 0 0 0 0 0 0 0 0 0 0 0 0 0 0 0 0 0 0 0 0 0 0 0 0 0 0 0 0 0 0 0 0 0 0 0 0 0 0 0 0 0 0 |    |    |    |    |    |    |    |    |    |    |    |    |    |    |    | Sub-server Length      |  |
| Sub-server Length (48B)                     | 0 0 0 0 0 0 0 0 0 0 0 0 1 1 0 0 0 0                                                                   |   |   |   |   |   |   |   |   |   |    |    |    |    |    | 0 0 0 0 0 0 0 0 0 0 0 0 0 0 0 0 0 0 0 0 0 0 0 0 0 0 0 0 0 0 0 0 0 0 0 0 0 0 0 0 0 0 0 0 0 0 0 0 0 |    |    |    |    |    |    |    |    |    |    |    |    |    |    |    | String Block Header    |  |
| String Block Header (0)                     | 0 0 0 0 0 0 0 0 0 0 0 0 0 0 0 0 0 0 0 0 0 0 0 0 0 0 0 0 0 0 0 0 0 0 0 0 0 0 0 0 0 0 0 0 0 0 0 0 0     |   |   |   |   |   |   |   |   |   |    |    |    |    |    |                                                                                                   |    |    |    |    |    |    |    |    |    |    |    |    |    |    |    | String Block Size      |  |
| String Block Size (16B)                     | 0 0 0 0 0 0 0 0 0 0 0 0 0 1 0 0 0 0                                                                   |   |   |   |   |   |   |   |   |   |    |    |    |    |    | 0 1 0 0 1 1 1 1 0 1 1 1 0 0 0 0                                                                   |    |    |    |    |    |    |    |    |    |    |    |    |    |    |    |                        |  |
| Sub-server Name - OpenSSL                   | 0 1 1 0 0 1 0 1 0 1 1 0 1 1 1 0 0 1 0 1 0 0 1 1 0 1 0 1 0 1 0 0 1 1 0 1 0 0 0 0 0 0 0 0 0 0 0 0 0 0   |   |   |   |   |   |   |   |   |   |    |    |    |    |    |                                                                                                   |    |    |    |    |    |    |    |    |    |    |    |    |    |    |    |                        |  |
|                                             | 0 1 0 0 1 1 0 0 0 0 0 0 0 0 0 0 0                                                                     |   |   |   |   |   |   |   |   |   |    |    |    |    |    | 0 0 0 0 0 0 0 0 0 0 0 0 0 0 0 0 0 0 0 0 0 0 0 0 0 0 0 0 0 0 0 0 0 0 0 0 0 0 0 0 0 0 0 0 0 0 0 0 0 |    |    |    |    |    |    |    |    |    |    |    |    |    |    |    | String Block Header    |  |

| Byte                                                                                        | 0 |   |   |   |   |   |   |   | 1 |   |    |    |    |    |    |    | 2  |    |    |    |    |    |    |    | 3  |    |    |    |    |    |    |                       |                     |
|---------------------------------------------------------------------------------------------|---|---|---|---|---|---|---|---|---|---|----|----|----|----|----|----|----|----|----|----|----|----|----|----|----|----|----|----|----|----|----|-----------------------|---------------------|
| Bit                                                                                         | 0 | 1 | 2 | 3 | 4 | 5 | 6 | 7 | 8 | 9 | 10 | 11 | 12 | 13 | 14 | 15 | 16 | 17 | 18 | 19 | 20 | 21 | 22 | 23 | 24 | 25 | 26 | 27 | 28 | 29 | 30 | 31                    |                     |
| String Block Header (0)                                                                     | 0 | 0 | 0 | 0 | 0 | 0 | 0 | 0 | 0 | 0 | 0  | 0  | 0  | 0  | 0  | 0  | 0  | 0  | 0  | 0  | 0  | 0  | 0  | 0  | 0  | 0  | 0  | 0  | 0  | 0  | 0  | 0                     | String Data Length  |
| String Length (8-no vendor)                                                                 | 0 | 0 | 0 | 0 | 0 | 0 | 0 | 0 | 0 | 0 | 0  | 0  | 0  | 0  | 1  | 0  | 0  | 0  | 0  | 0  | 0  | 0  | 0  | 0  | 0  | 0  | 0  | 0  | 0  | 0  | 0  | 0                     | String Block Header |
| String Block Hdr (0)                                                                        | 0 | 0 | 0 | 0 | 0 | 0 | 0 | 0 | 0 | 0 | 0  | 0  | 0  | 0  | 0  | 0  | 0  | 0  | 0  | 0  | 0  | 0  | 0  | 0  | 0  | 0  | 0  | 0  | 0  | 0  | 0  | 0                     | String Block Length |
| String Block Len (16B)                                                                      | 0 | 0 | 0 | 0 | 0 | 0 | 0 | 0 | 0 | 0 | 0  | 0  | 0  | 1  | 0  | 0  | 0  | 0  | 1  | 1  | 0  | 0  | 0  | 0  | 0  | 0  | 1  | 0  | 1  | 1  | 1  | 0                     |                     |
| Sub-server Version - 0.9.6.d + null byte                                                    | 0 | 0 | 1 | 1 | 1 | 0 | 0 | 1 | 0 | 0 | 1  | 0  | 1  | 1  | 1  | 0  | 0  | 0  | 1  | 1  | 0  | 1  | 1  | 0  | 0  | 0  | 1  | 0  | 1  | 1  | 1  | End Sub-server Block  |                     |
|                                                                                             | 0 | 1 | 1 | 0 | 0 | 1 | 0 | 0 | 0 | 0 | 0  | 0  | 0  | 0  | 0  | 0  | 0  | 0  | 0  | 0  | 0  | 0  | 0  | 0  | 0  | 0  | 0  | 0  | 0  | 0  | 0  | Confidence %          |                     |
| Confidence % (100)                                                                          | 0 | 0 | 0 | 0 | 0 | 0 | 0 | 0 | 0 | 1 | 1  | 0  | 0  | 1  | 0  | 0  | 0  | 0  | 1  | 1  | 1  | 1  | 0  | 0  | 1  | 1  | 0  | 1  | 0  | 1  | 1  | Last used             |                     |
| Last Used (1047242787)                                                                      | 1 | 0 | 1 | 0 | 1 | 0 | 0 | 0 | 0 | 0 | 1  | 0  | 0  | 0  | 1  | 1  | 0  | 0  | 0  | 0  | 0  | 0  | 0  | 0  | 0  | 0  | 0  | 0  | 0  | 0  | 0  | Blob Data Block       |                     |
| Blob Data Block (10)                                                                        | 0 | 0 | 0 | 0 | 0 | 0 | 0 | 0 | 0 | 0 | 0  | 0  | 0  | 1  | 0  | 1  | 0  | 0  | 0  | 0  | 0  | 0  | 0  | 0  | 0  | 0  | 0  | 0  | 0  | 0  | 0  | Blob Data Length      |                     |
| Blob Data Length (22B)                                                                      | 0 | 0 | 0 | 0 | 0 | 0 | 0 | 0 | 0 | 0 | 0  | 0  | 1  | 0  | 1  | 1  | 0  | 0  | 1  | 0  | 0  | 0  | 0  | 0  | 1  | 0  | 1  | 0  | 1  | 0  | 1  |                       |                     |
| Server Banner (HTTP/1.1 414 Reque)<br>-Server banner shortened for example, typically 256B. | 0 | 1 | 0 | 1 | 0 | 1 | 0 | 0 | 0 | 1 | 0  | 1  | 0  | 0  | 0  | 0  | 0  | 0  | 1  | 0  | 1  | 1  | 1  | 0  | 0  | 1  | 1  | 0  | 0  | 0  | 1  | End Server Data Block |                     |
|                                                                                             | 0 | 0 | 1 | 0 | 1 | 1 | 1 | 0 | 0 | 0 | 1  | 1  | 0  | 0  | 0  | 1  | 0  | 0  | 1  | 0  | 0  | 0  | 0  | 0  | 0  | 1  | 1  | 0  | 1  | 0  | 0  |                       |                     |
|                                                                                             | 0 | 0 | 1 | 1 | 0 | 0 | 0 | 1 | 0 | 0 | 1  | 1  | 0  | 1  | 0  | 0  | 0  | 0  | 1  | 0  | 0  | 0  | 0  | 0  | 1  | 0  | 1  | 0  | 0  | 1  | 0  |                       |                     |
|                                                                                             | 0 | 1 | 1 | 0 | 0 | 1 | 0 | 1 | 0 | 1 | 1  | 0  | 0  | 0  | 1  | 0  | 1  | 1  | 1  | 0  | 1  | 0  | 1  | 0  | 1  | 1  | 0  | 0  | 1  | 0  | 1  |                       |                     |







## Understanding Legacy Data Structures

---

This appendix contains information about data structures supported by eStreamer in previous versions of FireSIGHT System products.

If your client uses event stream requests with bits set to request data in older version formats, you can use the information in this appendix to identify the data structures of the data messages you receive.

Note that prior to version 5.0, separate detection engines were assigned IDs. For version 5.0, devices are assigned IDs. Based on the version, data structures reflect this.



**Note**

---

This appendix describes only data structures from version 4.9 or later of the FireSIGHT System. If you require documentation for structures from earlier data structure versions, contact Cisco Customer Support.

---

See the following sections for more information:

- [Legacy Intrusion Data Structures, page B-1](#)
- [Legacy Malware Event Data Structures, page B-32](#)
- [Legacy Discovery Data Structures, page B-55](#)
- [Legacy Connection Data Structures, page B-78](#)
- [Legacy File Event Data Structures, page B-109](#)
- [Legacy Correlation Event Data Structures, page B-124](#)
- [Legacy Host Data Structures, page B-132](#)

## Legacy Intrusion Data Structures

See the following sections for more information:

- [Intrusion Event \(IPv4\) Record 5.0.x - 5.1, page B-2](#)
- [Intrusion Event \(IPv6\) Record 5.0.x - 5.1, page B-6](#)
- [Intrusion Event Record 5.2.x, page B-11](#)
- [Intrusion Event Record 5.3, page B-17](#)
- [Intrusion Event Record 5.1.1.x, page B-24](#)
- [Intrusion Impact Alert Data, page B-29](#)
- [Intrusion Impact Alert Data, page B-29](#)

## Intrusion Event (IPv4) Record 5.0.x - 5.1

The fields in the intrusion event (IPv4) record are shaded in the following graphic. The record type is 207.

You request intrusion event records by setting the intrusion event flag or the extended requests flag in the request message. See [Request Flags, page 2-11](#) and [Submitting Extended Requests, page 2-4](#).

For version 5.0.x - 5.1 intrusion events, the event ID, the managed device ID, and the event second form a unique identifier.

|      |                                                               |   |   |   |   |   |   |   |              |   |    |    |    |    |    |    |                  |    |    |    |    |    |    |    |         |    |    |    |    |    |    |    |
|------|---------------------------------------------------------------|---|---|---|---|---|---|---|--------------|---|----|----|----|----|----|----|------------------|----|----|----|----|----|----|----|---------|----|----|----|----|----|----|----|
| Byte | 0                                                             |   |   |   |   |   |   |   | 1            |   |    |    |    |    |    |    | 2                |    |    |    |    |    |    |    | 3       |    |    |    |    |    |    |    |
| Bit  | 0                                                             | 1 | 2 | 3 | 4 | 5 | 6 | 7 | 8            | 9 | 10 | 11 | 12 | 13 | 14 | 15 | 16               | 17 | 18 | 19 | 20 | 21 | 22 | 23 | 24      | 25 | 26 | 27 | 28 | 29 | 30 | 31 |
|      | Header Version (1)                                            |   |   |   |   |   |   |   |              |   |    |    |    |    |    |    | Message Type (4) |    |    |    |    |    |    |    |         |    |    |    |    |    |    |    |
|      | Message Length                                                |   |   |   |   |   |   |   |              |   |    |    |    |    |    |    |                  |    |    |    |    |    |    |    |         |    |    |    |    |    |    |    |
|      | Record Type (207)                                             |   |   |   |   |   |   |   |              |   |    |    |    |    |    |    |                  |    |    |    |    |    |    |    |         |    |    |    |    |    |    |    |
|      | Record Length                                                 |   |   |   |   |   |   |   |              |   |    |    |    |    |    |    |                  |    |    |    |    |    |    |    |         |    |    |    |    |    |    |    |
|      | eStreamer Server Timestamp (in events, only if bit 23 is set) |   |   |   |   |   |   |   |              |   |    |    |    |    |    |    |                  |    |    |    |    |    |    |    |         |    |    |    |    |    |    |    |
|      | Reserved for Future Use (in events, only if bit 23 is set)    |   |   |   |   |   |   |   |              |   |    |    |    |    |    |    |                  |    |    |    |    |    |    |    |         |    |    |    |    |    |    |    |
|      | Device ID                                                     |   |   |   |   |   |   |   |              |   |    |    |    |    |    |    |                  |    |    |    |    |    |    |    |         |    |    |    |    |    |    |    |
|      | Event ID                                                      |   |   |   |   |   |   |   |              |   |    |    |    |    |    |    |                  |    |    |    |    |    |    |    |         |    |    |    |    |    |    |    |
|      | Event Second                                                  |   |   |   |   |   |   |   |              |   |    |    |    |    |    |    |                  |    |    |    |    |    |    |    |         |    |    |    |    |    |    |    |
|      | Event Microsecond                                             |   |   |   |   |   |   |   |              |   |    |    |    |    |    |    |                  |    |    |    |    |    |    |    |         |    |    |    |    |    |    |    |
|      | Rule ID (Signature ID)                                        |   |   |   |   |   |   |   |              |   |    |    |    |    |    |    |                  |    |    |    |    |    |    |    |         |    |    |    |    |    |    |    |
|      | Generator ID                                                  |   |   |   |   |   |   |   |              |   |    |    |    |    |    |    |                  |    |    |    |    |    |    |    |         |    |    |    |    |    |    |    |
|      | Rule Revision                                                 |   |   |   |   |   |   |   |              |   |    |    |    |    |    |    |                  |    |    |    |    |    |    |    |         |    |    |    |    |    |    |    |
|      | Classification ID                                             |   |   |   |   |   |   |   |              |   |    |    |    |    |    |    |                  |    |    |    |    |    |    |    |         |    |    |    |    |    |    |    |
|      | Priority ID                                                   |   |   |   |   |   |   |   |              |   |    |    |    |    |    |    |                  |    |    |    |    |    |    |    |         |    |    |    |    |    |    |    |
|      | Source IPv4 Address                                           |   |   |   |   |   |   |   |              |   |    |    |    |    |    |    |                  |    |    |    |    |    |    |    |         |    |    |    |    |    |    |    |
|      | Destination IPv4 Address                                      |   |   |   |   |   |   |   |              |   |    |    |    |    |    |    |                  |    |    |    |    |    |    |    |         |    |    |    |    |    |    |    |
|      | Source Port                                                   |   |   |   |   |   |   |   |              |   |    |    |    |    |    |    | Destination Port |    |    |    |    |    |    |    |         |    |    |    |    |    |    |    |
|      | IP Protocol ID                                                |   |   |   |   |   |   |   | Impact Flags |   |    |    |    |    |    |    | Impact           |    |    |    |    |    |    |    | Blocked |    |    |    |    |    |    |    |
|      | MPLS Label                                                    |   |   |   |   |   |   |   |              |   |    |    |    |    |    |    |                  |    |    |    |    |    |    |    |         |    |    |    |    |    |    |    |

| By<br>te | 0                                     |   |   |   |   |   |   |   | 1 |   |    |    |    |    |    |    | 2   |    |    |    |    |    |    |    | 3  |    |    |    |    |    |    |    |
|----------|---------------------------------------|---|---|---|---|---|---|---|---|---|----|----|----|----|----|----|-----|----|----|----|----|----|----|----|----|----|----|----|----|----|----|----|
|          | 0                                     | 1 | 2 | 3 | 4 | 5 | 6 | 7 | 8 | 9 | 10 | 11 | 12 | 13 | 14 | 15 | 16  | 17 | 18 | 19 | 20 | 21 | 22 | 23 | 24 | 25 | 26 | 27 | 28 | 29 | 30 | 31 |
| Bit      | VLAN ID                               |   |   |   |   |   |   |   |   |   |    |    |    |    |    |    | Pad |    |    |    |    |    |    |    |    |    |    |    |    |    |    |    |
|          | Policy UUID                           |   |   |   |   |   |   |   |   |   |    |    |    |    |    |    |     |    |    |    |    |    |    |    |    |    |    |    |    |    |    |    |
|          | Policy UUID, continued                |   |   |   |   |   |   |   |   |   |    |    |    |    |    |    |     |    |    |    |    |    |    |    |    |    |    |    |    |    |    |    |
|          | Policy UUID, continued                |   |   |   |   |   |   |   |   |   |    |    |    |    |    |    |     |    |    |    |    |    |    |    |    |    |    |    |    |    |    |    |
|          | Policy UUID, continued                |   |   |   |   |   |   |   |   |   |    |    |    |    |    |    |     |    |    |    |    |    |    |    |    |    |    |    |    |    |    |    |
|          | User ID                               |   |   |   |   |   |   |   |   |   |    |    |    |    |    |    |     |    |    |    |    |    |    |    |    |    |    |    |    |    |    |    |
|          | Web Application ID                    |   |   |   |   |   |   |   |   |   |    |    |    |    |    |    |     |    |    |    |    |    |    |    |    |    |    |    |    |    |    |    |
|          | Client Application ID                 |   |   |   |   |   |   |   |   |   |    |    |    |    |    |    |     |    |    |    |    |    |    |    |    |    |    |    |    |    |    |    |
|          | Application Protocol ID               |   |   |   |   |   |   |   |   |   |    |    |    |    |    |    |     |    |    |    |    |    |    |    |    |    |    |    |    |    |    |    |
|          | Access Control Rule ID                |   |   |   |   |   |   |   |   |   |    |    |    |    |    |    |     |    |    |    |    |    |    |    |    |    |    |    |    |    |    |    |
|          | Access Control Policy UUID            |   |   |   |   |   |   |   |   |   |    |    |    |    |    |    |     |    |    |    |    |    |    |    |    |    |    |    |    |    |    |    |
|          | Access Control Policy UUID, continued |   |   |   |   |   |   |   |   |   |    |    |    |    |    |    |     |    |    |    |    |    |    |    |    |    |    |    |    |    |    |    |
|          | Access Control Policy UUID, continued |   |   |   |   |   |   |   |   |   |    |    |    |    |    |    |     |    |    |    |    |    |    |    |    |    |    |    |    |    |    |    |
|          | Access Control Policy UUID, continued |   |   |   |   |   |   |   |   |   |    |    |    |    |    |    |     |    |    |    |    |    |    |    |    |    |    |    |    |    |    |    |
|          | Interface Ingress UUID                |   |   |   |   |   |   |   |   |   |    |    |    |    |    |    |     |    |    |    |    |    |    |    |    |    |    |    |    |    |    |    |
|          | Interface Ingress UUID, continued     |   |   |   |   |   |   |   |   |   |    |    |    |    |    |    |     |    |    |    |    |    |    |    |    |    |    |    |    |    |    |    |
|          | Interface Ingress UUID, continued     |   |   |   |   |   |   |   |   |   |    |    |    |    |    |    |     |    |    |    |    |    |    |    |    |    |    |    |    |    |    |    |
|          | Interface Ingress UUID, continued     |   |   |   |   |   |   |   |   |   |    |    |    |    |    |    |     |    |    |    |    |    |    |    |    |    |    |    |    |    |    |    |
|          | Interface Egress UUID                 |   |   |   |   |   |   |   |   |   |    |    |    |    |    |    |     |    |    |    |    |    |    |    |    |    |    |    |    |    |    |    |
|          | Interface Egress UUID, continued      |   |   |   |   |   |   |   |   |   |    |    |    |    |    |    |     |    |    |    |    |    |    |    |    |    |    |    |    |    |    |    |
|          | Interface Egress UUID, continued      |   |   |   |   |   |   |   |   |   |    |    |    |    |    |    |     |    |    |    |    |    |    |    |    |    |    |    |    |    |    |    |
|          | Interface Egress UUID, continued      |   |   |   |   |   |   |   |   |   |    |    |    |    |    |    |     |    |    |    |    |    |    |    |    |    |    |    |    |    |    |    |
|          | Security Zone Ingress UUID            |   |   |   |   |   |   |   |   |   |    |    |    |    |    |    |     |    |    |    |    |    |    |    |    |    |    |    |    |    |    |    |
|          | Security Zone Ingress UUID, continued |   |   |   |   |   |   |   |   |   |    |    |    |    |    |    |     |    |    |    |    |    |    |    |    |    |    |    |    |    |    |    |
|          | Security Zone Ingress UUID, continued |   |   |   |   |   |   |   |   |   |    |    |    |    |    |    |     |    |    |    |    |    |    |    |    |    |    |    |    |    |    |    |

|                                       |   |   |   |   |   |   |   |   |   |   |   |   |   |   |   |   |   |   |   |   |   |   |   |   |   |   |   |   |   |   |   |   |   |   |   |   |   |   |   |   |
|---------------------------------------|---|---|---|---|---|---|---|---|---|---|---|---|---|---|---|---|---|---|---|---|---|---|---|---|---|---|---|---|---|---|---|---|---|---|---|---|---|---|---|---|
| Byte                                  | 0 |   |   |   |   |   |   |   | 1 |   |   |   |   |   |   |   | 2 |   |   |   |   |   |   |   | 3 |   |   |   |   |   |   |   |   |   |   |   |   |   |   |   |
| Bit                                   | 0 | 1 | 2 | 3 | 4 | 5 | 6 | 7 | 8 | 9 | 0 | 1 | 1 | 1 | 1 | 1 | 1 | 1 | 1 | 1 | 1 | 1 | 1 | 1 | 1 | 1 | 1 | 1 | 2 | 2 | 2 | 2 | 2 | 2 | 2 | 2 | 2 | 2 | 3 | 3 |
| Security Zone Ingress UUID, continued |   |   |   |   |   |   |   |   |   |   |   |   |   |   |   |   |   |   |   |   |   |   |   |   |   |   |   |   |   |   |   |   |   |   |   |   |   |   |   |   |
| Security Zone Egress UUID             |   |   |   |   |   |   |   |   |   |   |   |   |   |   |   |   |   |   |   |   |   |   |   |   |   |   |   |   |   |   |   |   |   |   |   |   |   |   |   |   |
| Security Zone Egress UUID, continued  |   |   |   |   |   |   |   |   |   |   |   |   |   |   |   |   |   |   |   |   |   |   |   |   |   |   |   |   |   |   |   |   |   |   |   |   |   |   |   |   |
| Security Zone Egress UUID, continued  |   |   |   |   |   |   |   |   |   |   |   |   |   |   |   |   |   |   |   |   |   |   |   |   |   |   |   |   |   |   |   |   |   |   |   |   |   |   |   |   |
| Security Zone Egress UUID, continued  |   |   |   |   |   |   |   |   |   |   |   |   |   |   |   |   |   |   |   |   |   |   |   |   |   |   |   |   |   |   |   |   |   |   |   |   |   |   |   |   |

The following table describes each intrusion event record data field.

**Table B-1** Intrusion Event (IPv4) Record Fields

| Field                    | Data Type | Description                                                                                                                                                                                                                           |
|--------------------------|-----------|---------------------------------------------------------------------------------------------------------------------------------------------------------------------------------------------------------------------------------------|
| Device ID                | uint32    | Contains the identification number of the detecting managed device. You can obtain the managed device name by requesting Version 3 or 4 metadata. See <a href="#">Managed Device Record Metadata, page 3-30</a> for more information. |
| Event ID                 | uint32    | Event identification number.                                                                                                                                                                                                          |
| Event Second             | uint32    | UNIX timestamp (seconds since 01/01/1970) of the event's detection.                                                                                                                                                                   |
| Event Microsecond        | uint32    | Microsecond (one millionth of a second) increment of the timestamp of the event's detection.                                                                                                                                          |
| Rule ID (Signature ID)   | uint32    | Rule identification number that corresponds with the event.                                                                                                                                                                           |
| Generator ID             | uint32    | Identification number of the FireSIGHT System preprocessor that generated the event.                                                                                                                                                  |
| Rule Revision            | uint32    | Rule revision number.                                                                                                                                                                                                                 |
| Classification ID        | uint32    | Identification number of the event classification message.                                                                                                                                                                            |
| Priority ID              | uint32    | Identification number of the priority associated with the event.                                                                                                                                                                      |
| Source IPv4 Address      | uint8[4]  | Source IPv4 address used in the event, in address octets.                                                                                                                                                                             |
| Destination IPv4 Address | uint8[4]  | Destination IPv4 address used in the event, in address octets.                                                                                                                                                                        |
| Source Port              | uint16    | The source port number if the event protocol type is TCP or UDP.                                                                                                                                                                      |
| Destination Port         | uint16    | The destination port number if the event protocol type is TCP or UDP.                                                                                                                                                                 |

Table B-1 Intrusion Event (IPv4) Record Fields (continued)

| Field              | Data Type | Description                                                                                                                                                                                                                                                                                                                                                                                                                                                                                                                                                                                                                                                                                                                                                                                                                                                                                                                                                                                                                                                                                                                                                                                                                                                                                                                                                                                                                                                                                                                                                                                                                                                                                                        |
|--------------------|-----------|--------------------------------------------------------------------------------------------------------------------------------------------------------------------------------------------------------------------------------------------------------------------------------------------------------------------------------------------------------------------------------------------------------------------------------------------------------------------------------------------------------------------------------------------------------------------------------------------------------------------------------------------------------------------------------------------------------------------------------------------------------------------------------------------------------------------------------------------------------------------------------------------------------------------------------------------------------------------------------------------------------------------------------------------------------------------------------------------------------------------------------------------------------------------------------------------------------------------------------------------------------------------------------------------------------------------------------------------------------------------------------------------------------------------------------------------------------------------------------------------------------------------------------------------------------------------------------------------------------------------------------------------------------------------------------------------------------------------|
| IP Protocol Number | uint8     | IANA-specified protocol number. For example: <ul style="list-style-type: none"> <li>0 - IP</li> <li>1 - ICMP</li> <li>6 - TCP</li> <li>17 - UDP</li> </ul>                                                                                                                                                                                                                                                                                                                                                                                                                                                                                                                                                                                                                                                                                                                                                                                                                                                                                                                                                                                                                                                                                                                                                                                                                                                                                                                                                                                                                                                                                                                                                         |
| Impact Flags       | bits[8]   | Impact flag value of the event. The low-order eight bits indicate the impact level. Values are: <ul style="list-style-type: none"> <li>0x01 (bit 0) - Source or destination host is in a network monitored by the system.</li> <li>0x02 (bit 1) - Source or destination host exists in the network map.</li> <li>0x04 (bit 2) - Source or destination host is running a server on the port in the event (if TCP or UDP) or uses the IP protocol.</li> <li>0x08 (bit 3) - There is a vulnerability mapped to the operating system of the source or destination host in the event.</li> <li>0x10 (bit 4) - There is a vulnerability mapped to the server detected in the event.</li> <li>0x20 (bit 5) - The event caused the managed device to drop the session (used only when the device is running in inline, switched, or routed deployment). Corresponds to blocked status in the FireSIGHT System web interface.</li> <li>0x40 (bit 6) - The rule that generated this event contains rule metadata setting the impact flag to red. The source or destination host is potentially compromised by a virus, trojan, or other piece of malicious software.</li> <li>0x80 (bit 7) - There is a vulnerability mapped to the client detected in the event.</li> </ul> <p>The following impact level values map to specific priorities on the Defense Center. An x indicates the value can be 0 or 1:</p> <ul style="list-style-type: none"> <li>gray (0, unknown): 00X00000</li> <li>red (1, vulnerable): XXXX1XXX, XXX1XXXX, X1XXXXXX, 1XXXXXXX</li> <li>orange (2, potentially vulnerable): 00X00111</li> <li>yellow (3, currently not vulnerable): 00X00011</li> <li>blue (4, unknown target): 00X00001</li> </ul> |
| Impact             | uint8     | Impact flag value of the event. Values are: <ul style="list-style-type: none"> <li>1 - Red (vulnerable)</li> <li>2 - Orange (potentially vulnerable)</li> <li>3 - Yellow (currently not vulnerable)</li> <li>4 - Blue (unknown target)</li> <li>5 - Gray (unknown impact)</li> </ul>                                                                                                                                                                                                                                                                                                                                                                                                                                                                                                                                                                                                                                                                                                                                                                                                                                                                                                                                                                                                                                                                                                                                                                                                                                                                                                                                                                                                                               |

**Table B-1** *Intrusion Event (IPv4) Record Fields (continued)*

| Field                      | Data Type | Description                                                                                                                                                                                               |
|----------------------------|-----------|-----------------------------------------------------------------------------------------------------------------------------------------------------------------------------------------------------------|
| Blocked                    | uint8     | Value indicating whether the event was blocked: <ul style="list-style-type: none"> <li>0 - not blocked</li> <li>1 - blocked</li> <li>2 - would be blocked (but not permitted by configuration)</li> </ul> |
| MPLS Label                 | uint32    | MPLS label.                                                                                                                                                                                               |
| VLAN ID                    | uint16    | Indicates the ID of the VLAN where the packet originated.                                                                                                                                                 |
| Pad                        | uint16    | Reserved for future use.                                                                                                                                                                                  |
| Policy UUID                | uint8[16] | A policy ID number that acts as a unique identifier for the intrusion policy.                                                                                                                             |
| User ID                    | uint32    | The internal identification number for the user, if applicable.                                                                                                                                           |
| Web Application ID         | uint32    | The internal identification number for the web application, if applicable.                                                                                                                                |
| Client Application ID      | uint32    | The internal identification number for the client application, if applicable.                                                                                                                             |
| Application Protocol ID    | uint32    | The internal identification number for the application protocol, if applicable.                                                                                                                           |
| Access Control Rule ID     | uint32    | A rule ID number that acts as a unique identifier for the access control rule.                                                                                                                            |
| Access Control Policy UUID | uint8[16] | A policy ID number that acts as a unique identifier for the access control policy.                                                                                                                        |
| Ingress Interface UUID     | uint8[16] | An interface ID number that acts as a unique identifier for the ingress interface.                                                                                                                        |
| Egress Interface UUID      | uint8[16] | An interface ID number that acts as a unique identifier for the egress interface.                                                                                                                         |
| Ingress Security Zone UUID | uint8[16] | A zone ID number that acts as a unique identifier for the ingress security zone.                                                                                                                          |
| Egress Security Zone UUID  | uint8[16] | A zone ID number that acts as a unique identifier for the egress security zone.                                                                                                                           |

## Intrusion Event (IPv6) Record 5.0.x - 5.1

The fields in the intrusion event (IPv6) record are shaded in the following graphic. The record type is 208.

You request intrusion event records by setting the intrusion event flag or the extended requests flag in the request message. See [Request Flags, page 2-11](#) and [Submitting Extended Requests, page 2-4](#).

For version 5.0.x - 5.1 intrusion events, the event ID, the managed device ID, and the event second form a unique identifier.

|                                                               |                    |   |   |   |   |   |   |              |   |   |    |    |    |    |    |                            |                  |    |    |    |    |    |    |         |    |    |    |    |    |    |    |    |
|---------------------------------------------------------------|--------------------|---|---|---|---|---|---|--------------|---|---|----|----|----|----|----|----------------------------|------------------|----|----|----|----|----|----|---------|----|----|----|----|----|----|----|----|
| By<br>te                                                      | 0                  |   |   |   |   |   |   |              | 1 |   |    |    |    |    |    |                            | 2                |    |    |    |    |    |    |         | 3  |    |    |    |    |    |    |    |
|                                                               | 0                  | 1 | 2 | 3 | 4 | 5 | 6 | 7            | 8 | 9 | 10 | 11 | 12 | 13 | 14 | 15                         | 16               | 17 | 18 | 19 | 20 | 21 | 22 | 23      | 24 | 25 | 26 | 27 | 28 | 29 | 30 | 31 |
| Bit                                                           | Header Version (1) |   |   |   |   |   |   |              |   |   |    |    |    |    |    |                            | Message Type (4) |    |    |    |    |    |    |         |    |    |    |    |    |    |    |    |
| Message Length                                                |                    |   |   |   |   |   |   |              |   |   |    |    |    |    |    |                            |                  |    |    |    |    |    |    |         |    |    |    |    |    |    |    |    |
| Record Type (208)                                             |                    |   |   |   |   |   |   |              |   |   |    |    |    |    |    |                            |                  |    |    |    |    |    |    |         |    |    |    |    |    |    |    |    |
| Record Length                                                 |                    |   |   |   |   |   |   |              |   |   |    |    |    |    |    |                            |                  |    |    |    |    |    |    |         |    |    |    |    |    |    |    |    |
| eStreamer Server Timestamp (in events, only if bit 23 is set) |                    |   |   |   |   |   |   |              |   |   |    |    |    |    |    |                            |                  |    |    |    |    |    |    |         |    |    |    |    |    |    |    |    |
| Reserved for Future Use (in events, only if bit 23 is set)    |                    |   |   |   |   |   |   |              |   |   |    |    |    |    |    |                            |                  |    |    |    |    |    |    |         |    |    |    |    |    |    |    |    |
| Device ID                                                     |                    |   |   |   |   |   |   |              |   |   |    |    |    |    |    |                            |                  |    |    |    |    |    |    |         |    |    |    |    |    |    |    |    |
| Event ID                                                      |                    |   |   |   |   |   |   |              |   |   |    |    |    |    |    |                            |                  |    |    |    |    |    |    |         |    |    |    |    |    |    |    |    |
| Event Second                                                  |                    |   |   |   |   |   |   |              |   |   |    |    |    |    |    |                            |                  |    |    |    |    |    |    |         |    |    |    |    |    |    |    |    |
| Event Microsecond                                             |                    |   |   |   |   |   |   |              |   |   |    |    |    |    |    |                            |                  |    |    |    |    |    |    |         |    |    |    |    |    |    |    |    |
| Rule ID (Signature ID)                                        |                    |   |   |   |   |   |   |              |   |   |    |    |    |    |    |                            |                  |    |    |    |    |    |    |         |    |    |    |    |    |    |    |    |
| Generator ID                                                  |                    |   |   |   |   |   |   |              |   |   |    |    |    |    |    |                            |                  |    |    |    |    |    |    |         |    |    |    |    |    |    |    |    |
| Rule Revision                                                 |                    |   |   |   |   |   |   |              |   |   |    |    |    |    |    |                            |                  |    |    |    |    |    |    |         |    |    |    |    |    |    |    |    |
| Classification ID                                             |                    |   |   |   |   |   |   |              |   |   |    |    |    |    |    |                            |                  |    |    |    |    |    |    |         |    |    |    |    |    |    |    |    |
| Priority ID                                                   |                    |   |   |   |   |   |   |              |   |   |    |    |    |    |    |                            |                  |    |    |    |    |    |    |         |    |    |    |    |    |    |    |    |
| Source IPv6 Address                                           |                    |   |   |   |   |   |   |              |   |   |    |    |    |    |    |                            |                  |    |    |    |    |    |    |         |    |    |    |    |    |    |    |    |
| Source IPv6 Address, continued                                |                    |   |   |   |   |   |   |              |   |   |    |    |    |    |    |                            |                  |    |    |    |    |    |    |         |    |    |    |    |    |    |    |    |
| Source IPv6 Address, continued                                |                    |   |   |   |   |   |   |              |   |   |    |    |    |    |    |                            |                  |    |    |    |    |    |    |         |    |    |    |    |    |    |    |    |
| Source IPv6 Address, continued                                |                    |   |   |   |   |   |   |              |   |   |    |    |    |    |    |                            |                  |    |    |    |    |    |    |         |    |    |    |    |    |    |    |    |
| Destination IPv6 Address                                      |                    |   |   |   |   |   |   |              |   |   |    |    |    |    |    |                            |                  |    |    |    |    |    |    |         |    |    |    |    |    |    |    |    |
| Destination IPv6 Address, continued                           |                    |   |   |   |   |   |   |              |   |   |    |    |    |    |    |                            |                  |    |    |    |    |    |    |         |    |    |    |    |    |    |    |    |
| Destination IPv6 Address, continued                           |                    |   |   |   |   |   |   |              |   |   |    |    |    |    |    |                            |                  |    |    |    |    |    |    |         |    |    |    |    |    |    |    |    |
| Destination IPv6 Address, continued                           |                    |   |   |   |   |   |   |              |   |   |    |    |    |    |    |                            |                  |    |    |    |    |    |    |         |    |    |    |    |    |    |    |    |
| Source Port/ICMP Type                                         |                    |   |   |   |   |   |   |              |   |   |    |    |    |    |    | Destination Port/ICMP Code |                  |    |    |    |    |    |    |         |    |    |    |    |    |    |    |    |
| IP Protocol ID                                                |                    |   |   |   |   |   |   | Impact Flags |   |   |    |    |    |    |    | Impact                     |                  |    |    |    |    |    |    | Blocked |    |    |    |    |    |    |    |    |

| By<br>te | 0                                     |   |   |   |   |   |   |   | 1 |   |    |    |    |    |    |    | 2   |    |    |    |    |    |    |    | 3  |    |    |    |    |    |    |    |
|----------|---------------------------------------|---|---|---|---|---|---|---|---|---|----|----|----|----|----|----|-----|----|----|----|----|----|----|----|----|----|----|----|----|----|----|----|
|          | 0                                     | 1 | 2 | 3 | 4 | 5 | 6 | 7 | 8 | 9 | 10 | 11 | 12 | 13 | 14 | 15 | 16  | 17 | 18 | 19 | 20 | 21 | 22 | 23 | 24 | 25 | 26 | 27 | 28 | 29 | 30 | 31 |
|          | MPLS Label                            |   |   |   |   |   |   |   |   |   |    |    |    |    |    |    |     |    |    |    |    |    |    |    |    |    |    |    |    |    |    |    |
|          | VLAN ID                               |   |   |   |   |   |   |   |   |   |    |    |    |    |    |    | Pad |    |    |    |    |    |    |    |    |    |    |    |    |    |    |    |
|          | Policy UUID                           |   |   |   |   |   |   |   |   |   |    |    |    |    |    |    |     |    |    |    |    |    |    |    |    |    |    |    |    |    |    |    |
|          | Policy UUID, continued                |   |   |   |   |   |   |   |   |   |    |    |    |    |    |    |     |    |    |    |    |    |    |    |    |    |    |    |    |    |    |    |
|          | Policy UUID, continued                |   |   |   |   |   |   |   |   |   |    |    |    |    |    |    |     |    |    |    |    |    |    |    |    |    |    |    |    |    |    |    |
|          | Policy UUID, continued                |   |   |   |   |   |   |   |   |   |    |    |    |    |    |    |     |    |    |    |    |    |    |    |    |    |    |    |    |    |    |    |
|          | User ID                               |   |   |   |   |   |   |   |   |   |    |    |    |    |    |    |     |    |    |    |    |    |    |    |    |    |    |    |    |    |    |    |
|          | Web Application ID                    |   |   |   |   |   |   |   |   |   |    |    |    |    |    |    |     |    |    |    |    |    |    |    |    |    |    |    |    |    |    |    |
|          | Client Application ID                 |   |   |   |   |   |   |   |   |   |    |    |    |    |    |    |     |    |    |    |    |    |    |    |    |    |    |    |    |    |    |    |
|          | Application Protocol ID               |   |   |   |   |   |   |   |   |   |    |    |    |    |    |    |     |    |    |    |    |    |    |    |    |    |    |    |    |    |    |    |
|          | Access Control Rule ID                |   |   |   |   |   |   |   |   |   |    |    |    |    |    |    |     |    |    |    |    |    |    |    |    |    |    |    |    |    |    |    |
|          | Access Control Policy UUID            |   |   |   |   |   |   |   |   |   |    |    |    |    |    |    |     |    |    |    |    |    |    |    |    |    |    |    |    |    |    |    |
|          | Access Control Policy UUID, continued |   |   |   |   |   |   |   |   |   |    |    |    |    |    |    |     |    |    |    |    |    |    |    |    |    |    |    |    |    |    |    |
|          | Access Control Policy UUID, continued |   |   |   |   |   |   |   |   |   |    |    |    |    |    |    |     |    |    |    |    |    |    |    |    |    |    |    |    |    |    |    |
|          | Access Control Policy UUID, continued |   |   |   |   |   |   |   |   |   |    |    |    |    |    |    |     |    |    |    |    |    |    |    |    |    |    |    |    |    |    |    |
|          | Interface Ingress UUID                |   |   |   |   |   |   |   |   |   |    |    |    |    |    |    |     |    |    |    |    |    |    |    |    |    |    |    |    |    |    |    |
|          | Interface Ingress UUID, continued     |   |   |   |   |   |   |   |   |   |    |    |    |    |    |    |     |    |    |    |    |    |    |    |    |    |    |    |    |    |    |    |
|          | Interface Ingress UUID, continued     |   |   |   |   |   |   |   |   |   |    |    |    |    |    |    |     |    |    |    |    |    |    |    |    |    |    |    |    |    |    |    |
|          | Interface Ingress UUID, continued     |   |   |   |   |   |   |   |   |   |    |    |    |    |    |    |     |    |    |    |    |    |    |    |    |    |    |    |    |    |    |    |
|          | Interface Egress UUID                 |   |   |   |   |   |   |   |   |   |    |    |    |    |    |    |     |    |    |    |    |    |    |    |    |    |    |    |    |    |    |    |
|          | Interface Egress UUID, continued      |   |   |   |   |   |   |   |   |   |    |    |    |    |    |    |     |    |    |    |    |    |    |    |    |    |    |    |    |    |    |    |
|          | Interface Egress UUID, continued      |   |   |   |   |   |   |   |   |   |    |    |    |    |    |    |     |    |    |    |    |    |    |    |    |    |    |    |    |    |    |    |
|          | Interface Egress UUID, continued      |   |   |   |   |   |   |   |   |   |    |    |    |    |    |    |     |    |    |    |    |    |    |    |    |    |    |    |    |    |    |    |
|          | Security Zone Ingress UUID            |   |   |   |   |   |   |   |   |   |    |    |    |    |    |    |     |    |    |    |    |    |    |    |    |    |    |    |    |    |    |    |
|          | Security Zone Ingress UUID, continued |   |   |   |   |   |   |   |   |   |    |    |    |    |    |    |     |    |    |    |    |    |    |    |    |    |    |    |    |    |    |    |



|      |                                       |   |   |   |   |   |   |   |   |   |    |    |    |    |    |    |    |    |    |    |    |    |    |    |    |    |    |    |    |    |    |    |
|------|---------------------------------------|---|---|---|---|---|---|---|---|---|----|----|----|----|----|----|----|----|----|----|----|----|----|----|----|----|----|----|----|----|----|----|
| Byte | 0                                     |   |   |   |   |   |   |   | 1 |   |    |    |    |    |    |    | 2  |    |    |    |    |    |    |    | 3  |    |    |    |    |    |    |    |
| Bit  | 0                                     | 1 | 2 | 3 | 4 | 5 | 6 | 7 | 8 | 9 | 10 | 11 | 12 | 13 | 14 | 15 | 16 | 17 | 18 | 19 | 20 | 21 | 22 | 23 | 24 | 25 | 26 | 27 | 28 | 29 | 30 | 31 |
|      | Security Zone Ingress UUID, continued |   |   |   |   |   |   |   |   |   |    |    |    |    |    |    |    |    |    |    |    |    |    |    |    |    |    |    |    |    |    |    |
|      | Security Zone Ingress UUID, continued |   |   |   |   |   |   |   |   |   |    |    |    |    |    |    |    |    |    |    |    |    |    |    |    |    |    |    |    |    |    |    |
|      | Security Zone Egress UUID             |   |   |   |   |   |   |   |   |   |    |    |    |    |    |    |    |    |    |    |    |    |    |    |    |    |    |    |    |    |    |    |
|      | Security Zone Egress UUID, continued  |   |   |   |   |   |   |   |   |   |    |    |    |    |    |    |    |    |    |    |    |    |    |    |    |    |    |    |    |    |    |    |
|      | Security Zone Egress UUID, continued  |   |   |   |   |   |   |   |   |   |    |    |    |    |    |    |    |    |    |    |    |    |    |    |    |    |    |    |    |    |    |    |
|      | Security Zone Egress UUID, continued  |   |   |   |   |   |   |   |   |   |    |    |    |    |    |    |    |    |    |    |    |    |    |    |    |    |    |    |    |    |    |    |

The following table describes each intrusion event record data field.

**Table B-2** Intrusion Event (IPv6) Record Fields

| Field                      | Data Type | Description                                                                                                                                                                                                                   |
|----------------------------|-----------|-------------------------------------------------------------------------------------------------------------------------------------------------------------------------------------------------------------------------------|
| Device ID                  | uint32    | Contains the identification number of the detecting device. You can obtain the managed device name by requesting Version 3 or 4 metadata. See <a href="#">Managed Device Record Metadata, page 3-30</a> for more information. |
| Event ID                   | uint32    | Event identification number.                                                                                                                                                                                                  |
| Event Second               | uint32    | UNIX timestamp (seconds since 01/01/1970) of the event's detection.                                                                                                                                                           |
| Event Microsecond          | uint32    | Microsecond (one millionth of a second) increment of the timestamp of the event's detection.                                                                                                                                  |
| Rule ID (Signature ID)     | uint32    | Rule identification number that corresponds with the event.                                                                                                                                                                   |
| Generator ID               | uint32    | Identification number of the FireSIGHT System preprocessor that generated the event.                                                                                                                                          |
| Rule Revision              | uint32    | Rule revision number.                                                                                                                                                                                                         |
| Classification ID          | uint32    | Identification number of the event classification message.                                                                                                                                                                    |
| Priority ID                | uint32    | Identification number of the priority associated with the event.                                                                                                                                                              |
| Source IPv6 Address        | uint8[16] | Source IPv6 address used in the event, in address octets.                                                                                                                                                                     |
| Destination IPv6 Address   | uint8[16] | Destination IPv6 address used in the event, in address octets.                                                                                                                                                                |
| Source Port/ICMP Type      | uint16    | The source port number if the event protocol type is TCP or UDP. If the protocol type is ICMP, this indicates the ICMP type.                                                                                                  |
| Destination Port/ICMP Code | uint16    | The destination port number if the event protocol type is TCP or UDP. If the protocol type is ICMP, this indicates the ICMP code.                                                                                             |

Table B-2 Intrusion Event (IPv6) Record Fields (continued)

| Field              | Data Type | Description                                                                                                                                                                                                                                                                                                                                                                                                                                                                                                                                                                                                                                                                                                                                                                                                                                                                                                                                                                                                                                                                                                                                                                                                                                                                                                                                                                                                                                                                                                                                                                                                                                                                                                               |
|--------------------|-----------|---------------------------------------------------------------------------------------------------------------------------------------------------------------------------------------------------------------------------------------------------------------------------------------------------------------------------------------------------------------------------------------------------------------------------------------------------------------------------------------------------------------------------------------------------------------------------------------------------------------------------------------------------------------------------------------------------------------------------------------------------------------------------------------------------------------------------------------------------------------------------------------------------------------------------------------------------------------------------------------------------------------------------------------------------------------------------------------------------------------------------------------------------------------------------------------------------------------------------------------------------------------------------------------------------------------------------------------------------------------------------------------------------------------------------------------------------------------------------------------------------------------------------------------------------------------------------------------------------------------------------------------------------------------------------------------------------------------------------|
| IP Protocol Number | uint8     | <p>IANA-specified protocol number. For example:</p> <ul style="list-style-type: none"> <li>0 - IP</li> <li>1 - ICMP</li> <li>6 - TCP</li> <li>17 - UDP</li> </ul>                                                                                                                                                                                                                                                                                                                                                                                                                                                                                                                                                                                                                                                                                                                                                                                                                                                                                                                                                                                                                                                                                                                                                                                                                                                                                                                                                                                                                                                                                                                                                         |
| Impact Flags       | bits[8]   | <p>Impact flag value of the event. The low-order eight bits indicate the impact level. Values are:</p> <ul style="list-style-type: none"> <li>0x01 (bit 0) - Source or destination host is in a network monitored by the system.</li> <li>0x02 (bit 1) - Source or destination host exists in the network map.</li> <li>0x04 (bit 2) - Source or destination host is running a server on the port in the event (if TCP or UDP) or uses the IP protocol.</li> <li>0x08 (bit 3) - There is a vulnerability mapped to the operating system of the source or destination host in the event.</li> <li>0x10 (bit 4) - There is a vulnerability mapped to the server detected in the event.</li> <li>0x20 (bit 5) - The event caused the managed device to drop the session (used only when the device is running in inline, switched, or routed deployment). Corresponds to blocked status in the FireSIGHT System web interface.</li> <li>0x40 (bit 6) - The rule that generated this event contains rule metadata setting the impact flag to red. The source or destination host is potentially compromised by a virus, trojan, or other piece of malicious software.</li> <li>0x80 (bit 7) - There is a vulnerability mapped to the client detected in the event.</li> </ul> <p>The following impact level values map to specific priorities on the Defense Center. An x indicates the value can be 0 or 1:</p> <ul style="list-style-type: none"> <li>gray (0, unknown): 00X00000</li> <li>red (1, vulnerable): XXXX1XXX, XXX1XXXX, X1XXXXXX, 1XXXXXXX</li> <li>orange (2, potentially vulnerable): 00X00111</li> <li>yellow (3, currently not vulnerable): 00X00011</li> <li>blue (4, unknown target): 00X00001</li> </ul> |
| Impact             | uint8     | <p>Impact flag value of the event. Values are:</p> <ul style="list-style-type: none"> <li>1 - Red (vulnerable)</li> <li>2 - Orange (potentially vulnerable)</li> <li>3 - Yellow (currently not vulnerable)</li> <li>4 - Blue (unknown target)</li> <li>5 - Gray (unknown impact)</li> </ul>                                                                                                                                                                                                                                                                                                                                                                                                                                                                                                                                                                                                                                                                                                                                                                                                                                                                                                                                                                                                                                                                                                                                                                                                                                                                                                                                                                                                                               |

**Table B-2** *Intrusion Event (IPv6) Record Fields (continued)*

| Field                      | Data Type | Description                                                                                                                                                                                                     |
|----------------------------|-----------|-----------------------------------------------------------------------------------------------------------------------------------------------------------------------------------------------------------------|
| Blocked                    | uint8     | Value indicating whether the event was blocked: <ul style="list-style-type: none"> <li>• 0 - not blocked</li> <li>• 1 - blocked</li> <li>• 2 - would be blocked (but not permitted by configuration)</li> </ul> |
| MPLS Label                 | uint32    | MPLS label. (Applies to 4.9+ events only.)                                                                                                                                                                      |
| VLAN ID                    | uint16    | Indicates the ID of the VLAN where the packet originated. (Applies to 4.9+ events only.)                                                                                                                        |
| Pad                        | uint16    | Reserved for future use.                                                                                                                                                                                        |
| Policy UUID                | uint8[16] | A policy ID number that acts as a unique identifier for the intrusion policy.                                                                                                                                   |
| User ID                    | uint32    | The internal identification number for the user, if applicable.                                                                                                                                                 |
| Web Application ID         | uint32    | The internal identification number for the web application, if applicable.                                                                                                                                      |
| Client Application ID      | uint32    | The internal identification number for the client application, if applicable.                                                                                                                                   |
| Application Protocol ID    | uint32    | The internal identification number for the application protocol, if applicable.                                                                                                                                 |
| Access Control Rule ID     | uint32    | A rule ID number that acts as a unique identifier for the access control rule.                                                                                                                                  |
| Access Control Policy UUID | uint8[16] | A policy ID number that acts as a unique identifier for the access control policy.                                                                                                                              |
| Ingress Interface UUID     | uint8[16] | An interface ID number that acts as a unique identifier for the ingress interface.                                                                                                                              |
| Egress Interface UUID      | uint8[16] | An interface ID number that acts as a unique identifier for the egress interface.                                                                                                                               |
| Ingress Security Zone UUID | uint8[16] | A zone ID number that acts as a unique identifier for the ingress security zone.                                                                                                                                |
| Egress Security Zone UUID  | uint8[16] | A zone ID number that acts as a unique identifier for the egress security zone.                                                                                                                                 |

## Intrusion Event Record 5.2.x

The fields in the intrusion event record are shaded in the following graphic. The record type is 400 and the block type is 34 in the series 2 set of data blocks.

You can request 5.2.x intrusion events from eStreamer only by extended request, for which you request event type code 12 and version code 5 in the Stream Request message (see [Submitting Extended Requests, page 2-4](#) for information about submitting extended requests).

For version 5.2.x intrusion events, the event ID, the managed device ID, and the event second form a unique identifier. The connection second, connection instance, and connection counter together form a unique identifier for the connection event associated with the intrusion event.

| Byte | 0                                                             |   |   |   |   |   |   |   | 1 |   |    |    |    |    |    |    | 2                |    |    |    |    |    |    |    | 3  |    |    |    |    |    |    |    |
|------|---------------------------------------------------------------|---|---|---|---|---|---|---|---|---|----|----|----|----|----|----|------------------|----|----|----|----|----|----|----|----|----|----|----|----|----|----|----|
| Bit  | 0                                                             | 1 | 2 | 3 | 4 | 5 | 6 | 7 | 8 | 9 | 10 | 11 | 12 | 13 | 14 | 15 | 16               | 17 | 18 | 19 | 20 | 21 | 22 | 23 | 24 | 25 | 26 | 27 | 28 | 29 | 30 | 31 |
|      | Header Version (1)                                            |   |   |   |   |   |   |   |   |   |    |    |    |    |    |    | Message Type (4) |    |    |    |    |    |    |    |    |    |    |    |    |    |    |    |
|      | Message Length                                                |   |   |   |   |   |   |   |   |   |    |    |    |    |    |    |                  |    |    |    |    |    |    |    |    |    |    |    |    |    |    |    |
|      | Record Type (400)                                             |   |   |   |   |   |   |   |   |   |    |    |    |    |    |    |                  |    |    |    |    |    |    |    |    |    |    |    |    |    |    |    |
|      | Record Length                                                 |   |   |   |   |   |   |   |   |   |    |    |    |    |    |    |                  |    |    |    |    |    |    |    |    |    |    |    |    |    |    |    |
|      | eStreamer Server Timestamp (in events, only if bit 23 is set) |   |   |   |   |   |   |   |   |   |    |    |    |    |    |    |                  |    |    |    |    |    |    |    |    |    |    |    |    |    |    |    |
|      | Reserved for Future Use (in events, only if bit 23 is set)    |   |   |   |   |   |   |   |   |   |    |    |    |    |    |    |                  |    |    |    |    |    |    |    |    |    |    |    |    |    |    |    |
|      | Block Type (34)                                               |   |   |   |   |   |   |   |   |   |    |    |    |    |    |    |                  |    |    |    |    |    |    |    |    |    |    |    |    |    |    |    |
|      | Block Length                                                  |   |   |   |   |   |   |   |   |   |    |    |    |    |    |    |                  |    |    |    |    |    |    |    |    |    |    |    |    |    |    |    |
|      | Device ID                                                     |   |   |   |   |   |   |   |   |   |    |    |    |    |    |    |                  |    |    |    |    |    |    |    |    |    |    |    |    |    |    |    |
|      | Event ID                                                      |   |   |   |   |   |   |   |   |   |    |    |    |    |    |    |                  |    |    |    |    |    |    |    |    |    |    |    |    |    |    |    |
|      | Event Second                                                  |   |   |   |   |   |   |   |   |   |    |    |    |    |    |    |                  |    |    |    |    |    |    |    |    |    |    |    |    |    |    |    |
|      | Event Microsecond                                             |   |   |   |   |   |   |   |   |   |    |    |    |    |    |    |                  |    |    |    |    |    |    |    |    |    |    |    |    |    |    |    |
|      | Rule ID (Signature ID)                                        |   |   |   |   |   |   |   |   |   |    |    |    |    |    |    |                  |    |    |    |    |    |    |    |    |    |    |    |    |    |    |    |
|      | Generator ID                                                  |   |   |   |   |   |   |   |   |   |    |    |    |    |    |    |                  |    |    |    |    |    |    |    |    |    |    |    |    |    |    |    |
|      | Rule Revision                                                 |   |   |   |   |   |   |   |   |   |    |    |    |    |    |    |                  |    |    |    |    |    |    |    |    |    |    |    |    |    |    |    |
|      | Classification ID                                             |   |   |   |   |   |   |   |   |   |    |    |    |    |    |    |                  |    |    |    |    |    |    |    |    |    |    |    |    |    |    |    |
|      | Priority ID                                                   |   |   |   |   |   |   |   |   |   |    |    |    |    |    |    |                  |    |    |    |    |    |    |    |    |    |    |    |    |    |    |    |
|      | Source IP Address                                             |   |   |   |   |   |   |   |   |   |    |    |    |    |    |    |                  |    |    |    |    |    |    |    |    |    |    |    |    |    |    |    |
|      | Source IP Address, continued                                  |   |   |   |   |   |   |   |   |   |    |    |    |    |    |    |                  |    |    |    |    |    |    |    |    |    |    |    |    |    |    |    |
|      | Source IP Address, continued                                  |   |   |   |   |   |   |   |   |   |    |    |    |    |    |    |                  |    |    |    |    |    |    |    |    |    |    |    |    |    |    |    |
|      | Source IP Address, continued                                  |   |   |   |   |   |   |   |   |   |    |    |    |    |    |    |                  |    |    |    |    |    |    |    |    |    |    |    |    |    |    |    |
|      | Destination IP Address                                        |   |   |   |   |   |   |   |   |   |    |    |    |    |    |    |                  |    |    |    |    |    |    |    |    |    |    |    |    |    |    |    |
|      | Destination IP Address, continued                             |   |   |   |   |   |   |   |   |   |    |    |    |    |    |    |                  |    |    |    |    |    |    |    |    |    |    |    |    |    |    |    |
|      | Destination IP Address, continued                             |   |   |   |   |   |   |   |   |   |    |    |    |    |    |    |                  |    |    |    |    |    |    |    |    |    |    |    |    |    |    |    |
|      | Destination IP Address, continued                             |   |   |   |   |   |   |   |   |   |    |    |    |    |    |    |                  |    |    |    |    |    |    |    |    |    |    |    |    |    |    |    |

|      |                                       |   |   |   |   |   |   |   |              |   |    |    |    |    |    |    |                               |    |    |    |    |    |    |    |         |    |    |    |    |    |    |    |
|------|---------------------------------------|---|---|---|---|---|---|---|--------------|---|----|----|----|----|----|----|-------------------------------|----|----|----|----|----|----|----|---------|----|----|----|----|----|----|----|
| Byte | 0                                     |   |   |   |   |   |   |   | 1            |   |    |    |    |    |    |    | 2                             |    |    |    |    |    |    |    | 3       |    |    |    |    |    |    |    |
| Bit  | 0                                     | 1 | 2 | 3 | 4 | 5 | 6 | 7 | 8            | 9 | 10 | 11 | 12 | 13 | 14 | 15 | 16                            | 17 | 18 | 19 | 20 | 21 | 22 | 23 | 24      | 25 | 26 | 27 | 28 | 29 | 30 | 31 |
|      | Source Port or ICMP Type              |   |   |   |   |   |   |   |              |   |    |    |    |    |    |    | Destination Port or ICMP Code |    |    |    |    |    |    |    |         |    |    |    |    |    |    |    |
|      | IP Protocol ID                        |   |   |   |   |   |   |   | Impact Flags |   |    |    |    |    |    |    | Impact                        |    |    |    |    |    |    |    | Blocked |    |    |    |    |    |    |    |
|      | MPLS Label                            |   |   |   |   |   |   |   |              |   |    |    |    |    |    |    |                               |    |    |    |    |    |    |    |         |    |    |    |    |    |    |    |
|      | VLAN ID                               |   |   |   |   |   |   |   |              |   |    |    |    |    |    |    | Pad                           |    |    |    |    |    |    |    |         |    |    |    |    |    |    |    |
|      | Policy UUID                           |   |   |   |   |   |   |   |              |   |    |    |    |    |    |    |                               |    |    |    |    |    |    |    |         |    |    |    |    |    |    |    |
|      | Policy UUID, continued                |   |   |   |   |   |   |   |              |   |    |    |    |    |    |    |                               |    |    |    |    |    |    |    |         |    |    |    |    |    |    |    |
|      | Policy UUID, continued                |   |   |   |   |   |   |   |              |   |    |    |    |    |    |    |                               |    |    |    |    |    |    |    |         |    |    |    |    |    |    |    |
|      | Policy UUID, continued                |   |   |   |   |   |   |   |              |   |    |    |    |    |    |    |                               |    |    |    |    |    |    |    |         |    |    |    |    |    |    |    |
|      | User ID                               |   |   |   |   |   |   |   |              |   |    |    |    |    |    |    |                               |    |    |    |    |    |    |    |         |    |    |    |    |    |    |    |
|      | Web Application ID                    |   |   |   |   |   |   |   |              |   |    |    |    |    |    |    |                               |    |    |    |    |    |    |    |         |    |    |    |    |    |    |    |
|      | Client Application ID                 |   |   |   |   |   |   |   |              |   |    |    |    |    |    |    |                               |    |    |    |    |    |    |    |         |    |    |    |    |    |    |    |
|      | Application Protocol ID               |   |   |   |   |   |   |   |              |   |    |    |    |    |    |    |                               |    |    |    |    |    |    |    |         |    |    |    |    |    |    |    |
|      | Access Control Rule ID                |   |   |   |   |   |   |   |              |   |    |    |    |    |    |    |                               |    |    |    |    |    |    |    |         |    |    |    |    |    |    |    |
|      | Access Control Policy UUID            |   |   |   |   |   |   |   |              |   |    |    |    |    |    |    |                               |    |    |    |    |    |    |    |         |    |    |    |    |    |    |    |
|      | Access Control Policy UUID, continued |   |   |   |   |   |   |   |              |   |    |    |    |    |    |    |                               |    |    |    |    |    |    |    |         |    |    |    |    |    |    |    |
|      | Access Control Policy UUID, continued |   |   |   |   |   |   |   |              |   |    |    |    |    |    |    |                               |    |    |    |    |    |    |    |         |    |    |    |    |    |    |    |
|      | Access Control Policy UUID, continued |   |   |   |   |   |   |   |              |   |    |    |    |    |    |    |                               |    |    |    |    |    |    |    |         |    |    |    |    |    |    |    |
|      | Interface Ingress UUID                |   |   |   |   |   |   |   |              |   |    |    |    |    |    |    |                               |    |    |    |    |    |    |    |         |    |    |    |    |    |    |    |
|      | Interface Ingress UUID, continued     |   |   |   |   |   |   |   |              |   |    |    |    |    |    |    |                               |    |    |    |    |    |    |    |         |    |    |    |    |    |    |    |
|      | Interface Ingress UUID, continued     |   |   |   |   |   |   |   |              |   |    |    |    |    |    |    |                               |    |    |    |    |    |    |    |         |    |    |    |    |    |    |    |
|      | Interface Ingress UUID, continued     |   |   |   |   |   |   |   |              |   |    |    |    |    |    |    |                               |    |    |    |    |    |    |    |         |    |    |    |    |    |    |    |
|      | Interface Egress UUID                 |   |   |   |   |   |   |   |              |   |    |    |    |    |    |    |                               |    |    |    |    |    |    |    |         |    |    |    |    |    |    |    |
|      | Interface Egress UUID, continued      |   |   |   |   |   |   |   |              |   |    |    |    |    |    |    |                               |    |    |    |    |    |    |    |         |    |    |    |    |    |    |    |
|      | Interface Egress UUID, continued      |   |   |   |   |   |   |   |              |   |    |    |    |    |    |    |                               |    |    |    |    |    |    |    |         |    |    |    |    |    |    |    |
|      | Interface Egress UUID, continued      |   |   |   |   |   |   |   |              |   |    |    |    |    |    |    |                               |    |    |    |    |    |    |    |         |    |    |    |    |    |    |    |
|      | Security Zone Ingress UUID            |   |   |   |   |   |   |   |              |   |    |    |    |    |    |    |                               |    |    |    |    |    |    |    |         |    |    |    |    |    |    |    |

|      |                                       |   |   |   |   |   |   |   |   |   |    |    |    |    |    |    |                     |    |    |    |    |    |    |    |    |    |    |    |    |    |    |    |
|------|---------------------------------------|---|---|---|---|---|---|---|---|---|----|----|----|----|----|----|---------------------|----|----|----|----|----|----|----|----|----|----|----|----|----|----|----|
| Byte | 0                                     |   |   |   |   |   |   |   | 1 |   |    |    |    |    |    |    | 2                   |    |    |    |    |    |    |    | 3  |    |    |    |    |    |    |    |
| Bit  | 0                                     | 1 | 2 | 3 | 4 | 5 | 6 | 7 | 8 | 9 | 10 | 11 | 12 | 13 | 14 | 15 | 16                  | 17 | 18 | 19 | 20 | 21 | 22 | 23 | 24 | 25 | 26 | 27 | 28 | 29 | 30 | 31 |
|      | Security Zone Ingress UUID, continued |   |   |   |   |   |   |   |   |   |    |    |    |    |    |    |                     |    |    |    |    |    |    |    |    |    |    |    |    |    |    |    |
|      | Security Zone Ingress UUID, continued |   |   |   |   |   |   |   |   |   |    |    |    |    |    |    |                     |    |    |    |    |    |    |    |    |    |    |    |    |    |    |    |
|      | Security Zone Ingress UUID, continued |   |   |   |   |   |   |   |   |   |    |    |    |    |    |    |                     |    |    |    |    |    |    |    |    |    |    |    |    |    |    |    |
|      | Security Zone Egress UUID             |   |   |   |   |   |   |   |   |   |    |    |    |    |    |    |                     |    |    |    |    |    |    |    |    |    |    |    |    |    |    |    |
|      | Security Zone Egress UUID, continued  |   |   |   |   |   |   |   |   |   |    |    |    |    |    |    |                     |    |    |    |    |    |    |    |    |    |    |    |    |    |    |    |
|      | Security Zone Egress UUID, continued  |   |   |   |   |   |   |   |   |   |    |    |    |    |    |    |                     |    |    |    |    |    |    |    |    |    |    |    |    |    |    |    |
|      | Security Zone Egress UUID, continued  |   |   |   |   |   |   |   |   |   |    |    |    |    |    |    |                     |    |    |    |    |    |    |    |    |    |    |    |    |    |    |    |
|      | Connection Timestamp                  |   |   |   |   |   |   |   |   |   |    |    |    |    |    |    |                     |    |    |    |    |    |    |    |    |    |    |    |    |    |    |    |
|      | Connection Instance ID                |   |   |   |   |   |   |   |   |   |    |    |    |    |    |    | Connection Counter  |    |    |    |    |    |    |    |    |    |    |    |    |    |    |    |
|      | Source Country                        |   |   |   |   |   |   |   |   |   |    |    |    |    |    |    | Destination Country |    |    |    |    |    |    |    |    |    |    |    |    |    |    |    |

The following table describes each intrusion event record data field.

**Table B-3** *Intrusion Event Record 5.2.x Fields*

| Field                  | Data Type | Description                                                                                                                                                                                                                           |
|------------------------|-----------|---------------------------------------------------------------------------------------------------------------------------------------------------------------------------------------------------------------------------------------|
| Block Type             | uint32    | Initiates an Intrusion Event data block. This value is always 34.                                                                                                                                                                     |
| Block Length           | uint32    | Total number of bytes in the Intrusion Event data block, including eight bytes for the Intrusion Event block type and length fields, plus the number of bytes of data that follows.                                                   |
| Device ID              | uint32    | Contains the identification number of the detecting managed device. You can obtain the managed device name by requesting Version 3 or 4 metadata. See <a href="#">Managed Device Record Metadata, page 3-30</a> for more information. |
| Event ID               | uint32    | Event identification number.                                                                                                                                                                                                          |
| Event Second           | uint32    | UNIX timestamp (seconds since 01/01/1970) of the event's detection.                                                                                                                                                                   |
| Event Microsecond      | uint32    | Microsecond (one millionth of a second) increment of the timestamp of the event's detection.                                                                                                                                          |
| Rule ID (Signature ID) | uint32    | Rule identification number that corresponds with the event.                                                                                                                                                                           |
| Generator ID           | uint32    | Identification number of the FireSIGHT System preprocessor that generated the event.                                                                                                                                                  |
| Rule Revision          | uint32    | Rule revision number.                                                                                                                                                                                                                 |
| Classification ID      | uint32    | Identification number of the event classification message.                                                                                                                                                                            |
| Priority ID            | uint32    | Identification number of the priority associated with the event.                                                                                                                                                                      |

**Table B-3** *Intrusion Event Record 5.2.x Fields (continued)*

| <b>Field</b>                  | <b>Data Type</b> | <b>Description</b>                                                                                                                                            |
|-------------------------------|------------------|---------------------------------------------------------------------------------------------------------------------------------------------------------------|
| Source IP Address             | uint8[16]        | Source IPv4 or IPv6 address used in the event.                                                                                                                |
| Destination IP Address        | uint8[16]        | Destination IPv4 or IPv6 address used in the event.                                                                                                           |
| Source Port or ICMP Type      | uint16           | The source port number if the event protocol type is TCP or UDP, or the ICMP type if the event is caused by ICMP traffic.                                     |
| Destination Port or ICMP Code | uint16           | The destination port number if the event protocol type is TCP or UDP, or the ICMP code if the event is caused by ICMP traffic.                                |
| IP Protocol Number            | uint8            | IANA-specified protocol number. For example: <ul style="list-style-type: none"><li>• 0 - IP</li><li>• 1 - ICMP</li><li>• 6 - TCP</li><li>• 17 - UDP</li></ul> |

Table B-3 Intrusion Event Record 5.2.x Fields (continued)

| Field        | Data Type | Description                                                                                                                                                                                                                                                                                                                                                                                                                                                                                                                                                                                                                                                                                                                                                                                                                                                                                                                                                                                                                                                                                                                                                                                                                                                                                                                                                                                                                                                                                                                                                                                                                                                                                                                                                       |
|--------------|-----------|-------------------------------------------------------------------------------------------------------------------------------------------------------------------------------------------------------------------------------------------------------------------------------------------------------------------------------------------------------------------------------------------------------------------------------------------------------------------------------------------------------------------------------------------------------------------------------------------------------------------------------------------------------------------------------------------------------------------------------------------------------------------------------------------------------------------------------------------------------------------------------------------------------------------------------------------------------------------------------------------------------------------------------------------------------------------------------------------------------------------------------------------------------------------------------------------------------------------------------------------------------------------------------------------------------------------------------------------------------------------------------------------------------------------------------------------------------------------------------------------------------------------------------------------------------------------------------------------------------------------------------------------------------------------------------------------------------------------------------------------------------------------|
| Impact Flags | bits[8]   | <p>Impact flag value of the event. The low-order eight bits indicate the impact level. Values are:</p> <ul style="list-style-type: none"> <li>0x01 (bit 0) - Source or destination host is in a network monitored by the system.</li> <li>0x02 (bit 1) - Source or destination host exists in the network map.</li> <li>0x04 (bit 2) - Source or destination host is running a server on the port in the event (if TCP or UDP) or uses the IP protocol.</li> <li>0x08 (bit 3) - There is a vulnerability mapped to the operating system of the source or destination host in the event.</li> <li>0x10 (bit 4) - There is a vulnerability mapped to the server detected in the event.</li> <li>0x20 (bit 5) - The event caused the managed device to drop the session (used only when the device is running in inline, switched, or routed deployment). Corresponds to blocked status in the FireSIGHT System web interface.</li> <li>0x40 (bit 6) - The rule that generated this event contains rule metadata setting the impact flag to red. The source or destination host is potentially compromised by a virus, trojan, or other piece of malicious software.</li> <li>0x80 (bit 7) - There is a vulnerability mapped to the client detected in the event. (version 5.0+ only)</li> </ul> <p>The following impact level values map to specific priorities on the Defense Center. An x indicates the value can be 0 or 1:</p> <ul style="list-style-type: none"> <li>gray (0, unknown): 00X00000</li> <li>red (1, vulnerable): XXXX1XXX, XXX1XXXX, X1XXXXXX, 1XXXXXXX (version 5.0+ only)</li> <li>orange (2, potentially vulnerable): 00X0011X</li> <li>yellow (3, currently not vulnerable): 00X0001X</li> <li>blue (4, unknown target): 00X00001</li> </ul> |
| Impact       | uint8     | <p>Impact flag value of the event. Values are:</p> <ul style="list-style-type: none"> <li>1 - Red (vulnerable)</li> <li>2 - Orange (potentially vulnerable)</li> <li>3 - Yellow (currently not vulnerable)</li> <li>4 - Blue (unknown target)</li> <li>5 - Gray (unknown impact)</li> </ul>                                                                                                                                                                                                                                                                                                                                                                                                                                                                                                                                                                                                                                                                                                                                                                                                                                                                                                                                                                                                                                                                                                                                                                                                                                                                                                                                                                                                                                                                       |
| Blocked      | uint8     | <p>Value indicating whether the event was blocked:</p> <ul style="list-style-type: none"> <li>0 - not blocked</li> <li>1 - blocked</li> <li>2 - would be blocked (but not permitted by configuration)</li> </ul>                                                                                                                                                                                                                                                                                                                                                                                                                                                                                                                                                                                                                                                                                                                                                                                                                                                                                                                                                                                                                                                                                                                                                                                                                                                                                                                                                                                                                                                                                                                                                  |



Table B-3 Intrusion Event Record 5.2.x Fields (continued)

| Field                      | Data Type | Description                                                                                            |
|----------------------------|-----------|--------------------------------------------------------------------------------------------------------|
| MPLS Label                 | uint32    | MPLS label.                                                                                            |
| VLAN ID                    | uint16    | Indicates the ID of the VLAN where the packet originated.                                              |
| Pad                        | uint16    | Reserved for future use.                                                                               |
| Policy UUID                | uint8[16] | A policy ID number that acts as a unique identifier for the intrusion policy.                          |
| User ID                    | uint32    | The internal identification number for the user, if applicable.                                        |
| Web Application ID         | uint32    | The internal identification number for the web application, if applicable.                             |
| Client Application ID      | uint32    | The internal identification number for the client application, if applicable.                          |
| Application Protocol ID    | uint32    | The internal identification number for the application protocol, if applicable.                        |
| Access Control Rule ID     | uint32    | A rule ID number that acts as a unique identifier for the access control rule.                         |
| Access Control Policy UUID | uint8[16] | A policy ID number that acts as a unique identifier for the access control policy.                     |
| Ingress Interface UUID     | uint8[16] | An interface ID number that acts as a unique identifier for the ingress interface.                     |
| Egress Interface UUID      | uint8[16] | An interface ID number that acts as a unique identifier for the egress interface.                      |
| Ingress Security Zone UUID | uint8[16] | A zone ID number that acts as a unique identifier for the ingress security zone.                       |
| Egress Security Zone UUID  | uint8[16] | A zone ID number that acts as a unique identifier for the egress security zone.                        |
| Connection Timestamp       | uint32    | UNIX timestamp (seconds since 01/01/1970) of the connection event associated with the intrusion event. |
| Connection Instance ID     | uint16    | Numerical ID of the Snort instance on the managed device that generated the connection event.          |
| Connection Counter         | uint16    | Value used to distinguish between connection events that happen during the same second.                |
| Source Country             | uint16    | Code for the country of the source host.                                                               |
| Destination Country        | uint16    | Code for the country of the destination host.                                                          |

## Intrusion Event Record 5.3

The fields in the intrusion event record are shaded in the following graphic. The record type is 400 and the block type is 41 in the series 2 set of data blocks.

You can request 5.3 intrusion events from eStreamer only by extended request, for which you request event type code 12 and version code 6 in the Stream Request message (see [Submitting Extended Requests, page 2-4](#) for information about submitting extended requests).

For version 5.3 intrusion events, the event ID, the managed device ID, and the event second form a unique identifier. The connection second, connection instance, and connection counter together form a unique identifier for the connection event associated with the intrusion event.

| Byte | 0                                                             |   |   |   |   |   |   |   | 1 |   |    |    |    |    |    |    | 2                |    |    |    |    |    |    |    | 3  |    |    |    |    |    |    |    |
|------|---------------------------------------------------------------|---|---|---|---|---|---|---|---|---|----|----|----|----|----|----|------------------|----|----|----|----|----|----|----|----|----|----|----|----|----|----|----|
| Bit  | 0                                                             | 1 | 2 | 3 | 4 | 5 | 6 | 7 | 8 | 9 | 10 | 11 | 12 | 13 | 14 | 15 | 16               | 17 | 18 | 19 | 20 | 21 | 22 | 23 | 24 | 25 | 26 | 27 | 28 | 29 | 30 | 31 |
|      | Header Version (1)                                            |   |   |   |   |   |   |   |   |   |    |    |    |    |    |    | Message Type (4) |    |    |    |    |    |    |    |    |    |    |    |    |    |    |    |
|      | Message Length                                                |   |   |   |   |   |   |   |   |   |    |    |    |    |    |    |                  |    |    |    |    |    |    |    |    |    |    |    |    |    |    |    |
|      | Record Type (400)                                             |   |   |   |   |   |   |   |   |   |    |    |    |    |    |    |                  |    |    |    |    |    |    |    |    |    |    |    |    |    |    |    |
|      | Record Length                                                 |   |   |   |   |   |   |   |   |   |    |    |    |    |    |    |                  |    |    |    |    |    |    |    |    |    |    |    |    |    |    |    |
|      | eStreamer Server Timestamp (in events, only if bit 23 is set) |   |   |   |   |   |   |   |   |   |    |    |    |    |    |    |                  |    |    |    |    |    |    |    |    |    |    |    |    |    |    |    |
|      | Reserved for Future Use (in events, only if bit 23 is set)    |   |   |   |   |   |   |   |   |   |    |    |    |    |    |    |                  |    |    |    |    |    |    |    |    |    |    |    |    |    |    |    |
|      | Block Type (41)                                               |   |   |   |   |   |   |   |   |   |    |    |    |    |    |    |                  |    |    |    |    |    |    |    |    |    |    |    |    |    |    |    |
|      | Block Length                                                  |   |   |   |   |   |   |   |   |   |    |    |    |    |    |    |                  |    |    |    |    |    |    |    |    |    |    |    |    |    |    |    |
|      | Device ID                                                     |   |   |   |   |   |   |   |   |   |    |    |    |    |    |    |                  |    |    |    |    |    |    |    |    |    |    |    |    |    |    |    |
|      | Event ID                                                      |   |   |   |   |   |   |   |   |   |    |    |    |    |    |    |                  |    |    |    |    |    |    |    |    |    |    |    |    |    |    |    |
|      | Event Second                                                  |   |   |   |   |   |   |   |   |   |    |    |    |    |    |    |                  |    |    |    |    |    |    |    |    |    |    |    |    |    |    |    |
|      | Event Microsecond                                             |   |   |   |   |   |   |   |   |   |    |    |    |    |    |    |                  |    |    |    |    |    |    |    |    |    |    |    |    |    |    |    |
|      | Rule ID (Signature ID)                                        |   |   |   |   |   |   |   |   |   |    |    |    |    |    |    |                  |    |    |    |    |    |    |    |    |    |    |    |    |    |    |    |
|      | Generator ID                                                  |   |   |   |   |   |   |   |   |   |    |    |    |    |    |    |                  |    |    |    |    |    |    |    |    |    |    |    |    |    |    |    |
|      | Rule Revision                                                 |   |   |   |   |   |   |   |   |   |    |    |    |    |    |    |                  |    |    |    |    |    |    |    |    |    |    |    |    |    |    |    |
|      | Classification ID                                             |   |   |   |   |   |   |   |   |   |    |    |    |    |    |    |                  |    |    |    |    |    |    |    |    |    |    |    |    |    |    |    |
|      | Priority ID                                                   |   |   |   |   |   |   |   |   |   |    |    |    |    |    |    |                  |    |    |    |    |    |    |    |    |    |    |    |    |    |    |    |
|      | Source IP Address                                             |   |   |   |   |   |   |   |   |   |    |    |    |    |    |    |                  |    |    |    |    |    |    |    |    |    |    |    |    |    |    |    |
|      | Source IP Address, continued                                  |   |   |   |   |   |   |   |   |   |    |    |    |    |    |    |                  |    |    |    |    |    |    |    |    |    |    |    |    |    |    |    |
|      | Source IP Address, continued                                  |   |   |   |   |   |   |   |   |   |    |    |    |    |    |    |                  |    |    |    |    |    |    |    |    |    |    |    |    |    |    |    |
|      | Source IP Address, continued                                  |   |   |   |   |   |   |   |   |   |    |    |    |    |    |    |                  |    |    |    |    |    |    |    |    |    |    |    |    |    |    |    |

|                                       |   |   |   |   |   |   |   |              |   |   |    |    |    |    |    |                               |    |    |    |    |    |    |    |         |    |    |    |    |    |    |    |    |
|---------------------------------------|---|---|---|---|---|---|---|--------------|---|---|----|----|----|----|----|-------------------------------|----|----|----|----|----|----|----|---------|----|----|----|----|----|----|----|----|
| Byte                                  | 0 |   |   |   |   |   |   |              | 1 |   |    |    |    |    |    |                               | 2  |    |    |    |    |    |    |         | 3  |    |    |    |    |    |    |    |
| Bit                                   | 0 | 1 | 2 | 3 | 4 | 5 | 6 | 7            | 8 | 9 | 10 | 11 | 12 | 13 | 14 | 15                            | 16 | 17 | 18 | 19 | 20 | 21 | 22 | 23      | 24 | 25 | 26 | 27 | 28 | 29 | 30 | 31 |
| Destination IP Address                |   |   |   |   |   |   |   |              |   |   |    |    |    |    |    |                               |    |    |    |    |    |    |    |         |    |    |    |    |    |    |    |    |
| Destination IP Address, continued     |   |   |   |   |   |   |   |              |   |   |    |    |    |    |    |                               |    |    |    |    |    |    |    |         |    |    |    |    |    |    |    |    |
| Destination IP Address, continued     |   |   |   |   |   |   |   |              |   |   |    |    |    |    |    |                               |    |    |    |    |    |    |    |         |    |    |    |    |    |    |    |    |
| Destination IP Address, continued     |   |   |   |   |   |   |   |              |   |   |    |    |    |    |    |                               |    |    |    |    |    |    |    |         |    |    |    |    |    |    |    |    |
| Source Port or ICMP Type              |   |   |   |   |   |   |   |              |   |   |    |    |    |    |    | Destination Port or ICMP Code |    |    |    |    |    |    |    |         |    |    |    |    |    |    |    |    |
| IP Protocol ID                        |   |   |   |   |   |   |   | Impact Flags |   |   |    |    |    |    |    | Impact                        |    |    |    |    |    |    |    | Blocked |    |    |    |    |    |    |    |    |
| MPLS Label                            |   |   |   |   |   |   |   |              |   |   |    |    |    |    |    |                               |    |    |    |    |    |    |    |         |    |    |    |    |    |    |    |    |
| VLAN ID                               |   |   |   |   |   |   |   |              |   |   |    |    |    |    |    | Pad                           |    |    |    |    |    |    |    |         |    |    |    |    |    |    |    |    |
| Policy UUID                           |   |   |   |   |   |   |   |              |   |   |    |    |    |    |    |                               |    |    |    |    |    |    |    |         |    |    |    |    |    |    |    |    |
| Policy UUID, continued                |   |   |   |   |   |   |   |              |   |   |    |    |    |    |    |                               |    |    |    |    |    |    |    |         |    |    |    |    |    |    |    |    |
| Policy UUID, continued                |   |   |   |   |   |   |   |              |   |   |    |    |    |    |    |                               |    |    |    |    |    |    |    |         |    |    |    |    |    |    |    |    |
| Policy UUID, continued                |   |   |   |   |   |   |   |              |   |   |    |    |    |    |    |                               |    |    |    |    |    |    |    |         |    |    |    |    |    |    |    |    |
| User ID                               |   |   |   |   |   |   |   |              |   |   |    |    |    |    |    |                               |    |    |    |    |    |    |    |         |    |    |    |    |    |    |    |    |
| Web Application ID                    |   |   |   |   |   |   |   |              |   |   |    |    |    |    |    |                               |    |    |    |    |    |    |    |         |    |    |    |    |    |    |    |    |
| Client Application ID                 |   |   |   |   |   |   |   |              |   |   |    |    |    |    |    |                               |    |    |    |    |    |    |    |         |    |    |    |    |    |    |    |    |
| Application Protocol ID               |   |   |   |   |   |   |   |              |   |   |    |    |    |    |    |                               |    |    |    |    |    |    |    |         |    |    |    |    |    |    |    |    |
| Access Control Rule ID                |   |   |   |   |   |   |   |              |   |   |    |    |    |    |    |                               |    |    |    |    |    |    |    |         |    |    |    |    |    |    |    |    |
| Access Control Policy UUID            |   |   |   |   |   |   |   |              |   |   |    |    |    |    |    |                               |    |    |    |    |    |    |    |         |    |    |    |    |    |    |    |    |
| Access Control Policy UUID, continued |   |   |   |   |   |   |   |              |   |   |    |    |    |    |    |                               |    |    |    |    |    |    |    |         |    |    |    |    |    |    |    |    |
| Access Control Policy UUID, continued |   |   |   |   |   |   |   |              |   |   |    |    |    |    |    |                               |    |    |    |    |    |    |    |         |    |    |    |    |    |    |    |    |
| Access Control Policy UUID, continued |   |   |   |   |   |   |   |              |   |   |    |    |    |    |    |                               |    |    |    |    |    |    |    |         |    |    |    |    |    |    |    |    |
| Interface Ingress UUID                |   |   |   |   |   |   |   |              |   |   |    |    |    |    |    |                               |    |    |    |    |    |    |    |         |    |    |    |    |    |    |    |    |
| Interface Ingress UUID, continued     |   |   |   |   |   |   |   |              |   |   |    |    |    |    |    |                               |    |    |    |    |    |    |    |         |    |    |    |    |    |    |    |    |
| Interface Ingress UUID, continued     |   |   |   |   |   |   |   |              |   |   |    |    |    |    |    |                               |    |    |    |    |    |    |    |         |    |    |    |    |    |    |    |    |
| Interface Ingress UUID, continued     |   |   |   |   |   |   |   |              |   |   |    |    |    |    |    |                               |    |    |    |    |    |    |    |         |    |    |    |    |    |    |    |    |
| Interface Egress UUID                 |   |   |   |   |   |   |   |              |   |   |    |    |    |    |    |                               |    |    |    |    |    |    |    |         |    |    |    |    |    |    |    |    |

| Byte                                  | 0 |   |   |   |   |   |   |   | 1 |   |    |    |    |    |    |                     | 2  |    |    |    |    |    |    |    | 3  |    |    |    |    |    |    |    |
|---------------------------------------|---|---|---|---|---|---|---|---|---|---|----|----|----|----|----|---------------------|----|----|----|----|----|----|----|----|----|----|----|----|----|----|----|----|
| Bit                                   | 0 | 1 | 2 | 3 | 4 | 5 | 6 | 7 | 8 | 9 | 10 | 11 | 12 | 13 | 14 | 15                  | 16 | 17 | 18 | 19 | 20 | 21 | 22 | 23 | 24 | 25 | 26 | 27 | 28 | 29 | 30 | 31 |
| Interface Egress UUID, continued      |   |   |   |   |   |   |   |   |   |   |    |    |    |    |    |                     |    |    |    |    |    |    |    |    |    |    |    |    |    |    |    |    |
| Interface Egress UUID, continued      |   |   |   |   |   |   |   |   |   |   |    |    |    |    |    |                     |    |    |    |    |    |    |    |    |    |    |    |    |    |    |    |    |
| Interface Egress UUID, continued      |   |   |   |   |   |   |   |   |   |   |    |    |    |    |    |                     |    |    |    |    |    |    |    |    |    |    |    |    |    |    |    |    |
| Security Zone Ingress UUID            |   |   |   |   |   |   |   |   |   |   |    |    |    |    |    |                     |    |    |    |    |    |    |    |    |    |    |    |    |    |    |    |    |
| Security Zone Ingress UUID, continued |   |   |   |   |   |   |   |   |   |   |    |    |    |    |    |                     |    |    |    |    |    |    |    |    |    |    |    |    |    |    |    |    |
| Security Zone Ingress UUID, continued |   |   |   |   |   |   |   |   |   |   |    |    |    |    |    |                     |    |    |    |    |    |    |    |    |    |    |    |    |    |    |    |    |
| Security Zone Ingress UUID, continued |   |   |   |   |   |   |   |   |   |   |    |    |    |    |    |                     |    |    |    |    |    |    |    |    |    |    |    |    |    |    |    |    |
| Security Zone Egress UUID             |   |   |   |   |   |   |   |   |   |   |    |    |    |    |    |                     |    |    |    |    |    |    |    |    |    |    |    |    |    |    |    |    |
| Security Zone Egress UUID, continued  |   |   |   |   |   |   |   |   |   |   |    |    |    |    |    |                     |    |    |    |    |    |    |    |    |    |    |    |    |    |    |    |    |
| Security Zone Egress UUID, continued  |   |   |   |   |   |   |   |   |   |   |    |    |    |    |    |                     |    |    |    |    |    |    |    |    |    |    |    |    |    |    |    |    |
| Security Zone Egress UUID, continued  |   |   |   |   |   |   |   |   |   |   |    |    |    |    |    |                     |    |    |    |    |    |    |    |    |    |    |    |    |    |    |    |    |
| Connection Timestamp                  |   |   |   |   |   |   |   |   |   |   |    |    |    |    |    |                     |    |    |    |    |    |    |    |    |    |    |    |    |    |    |    |    |
| Connection Instance ID                |   |   |   |   |   |   |   |   |   |   |    |    |    |    |    | Connection Counter  |    |    |    |    |    |    |    |    |    |    |    |    |    |    |    |    |
| Source Country                        |   |   |   |   |   |   |   |   |   |   |    |    |    |    |    | Destination Country |    |    |    |    |    |    |    |    |    |    |    |    |    |    |    |    |
| IOC Number                            |   |   |   |   |   |   |   |   |   |   |    |    |    |    |    |                     |    |    |    |    |    |    |    |    |    |    |    |    |    |    |    |    |

The following table describes each intrusion event record data field.

**Table B-4** Intrusion Event Record 5.3 Fields

| Field             | Data Type | Description                                                                                                                                                                                                                           |
|-------------------|-----------|---------------------------------------------------------------------------------------------------------------------------------------------------------------------------------------------------------------------------------------|
| Block Type        | uint32    | Initiates an Intrusion Event data block. This value is always 34.                                                                                                                                                                     |
| Block Length      | uint32    | Total number of bytes in the Intrusion Event data block, including eight bytes for the Intrusion Event block type and length fields, plus the number of bytes of data that follows.                                                   |
| Device ID         | uint32    | Contains the identification number of the detecting managed device. You can obtain the managed device name by requesting Version 3 or 4 metadata. See <a href="#">Managed Device Record Metadata, page 3-30</a> for more information. |
| Event ID          | uint32    | Event identification number.                                                                                                                                                                                                          |
| Event Second      | uint32    | UNIX timestamp (seconds since 01/01/1970) of the event's detection.                                                                                                                                                                   |
| Event Microsecond | uint32    | Microsecond (one millionth of a second) increment of the timestamp of the event's detection.                                                                                                                                          |

*Table B-4 Intrusion Event Record 5.3 Fields (continued)*

| Field                         | Data Type | Description                                                                                                                                                        |
|-------------------------------|-----------|--------------------------------------------------------------------------------------------------------------------------------------------------------------------|
| Rule ID<br>(Signature ID)     | uint32    | Rule identification number that corresponds with the event.                                                                                                        |
| Generator ID                  | uint32    | Identification number of the FireSIGHT System preprocessor that generated the event.                                                                               |
| Rule Revision                 | uint32    | Rule revision number.                                                                                                                                              |
| Classification ID             | uint32    | Identification number of the event classification message.                                                                                                         |
| Priority ID                   | uint32    | Identification number of the priority associated with the event.                                                                                                   |
| Source IP Address             | uint8[16] | Source IPv4 or IPv6 address used in the event.                                                                                                                     |
| Destination IP Address        | uint8[16] | Destination IPv4 or IPv6 address used in the event.                                                                                                                |
| Source Port or ICMP Type      | uint16    | The source port number if the event protocol type is TCP or UDP, or the ICMP type if the event is caused by ICMP traffic.                                          |
| Destination Port or ICMP Code | uint16    | The destination port number if the event protocol type is TCP or UDP, or the ICMP code if the event is caused by ICMP traffic.                                     |
| IP Protocol Number            | uint8     | IANA-specified protocol number. For example: <ul style="list-style-type: none"> <li>• 0 - IP</li> <li>• 1 - ICMP</li> <li>• 6 - TCP</li> <li>• 17 - UDP</li> </ul> |

Table B-4 Intrusion Event Record 5.3 Fields (continued)

| Field        | Data Type | Description                                                                                                                                                                                                                                                                                                                                                                                                                                                                                                                                                                                                                                                                                                                                                                                                                                                                                                                                                                                                                                                                                                                                                                                                                                                                                                                                                                                                                                                                                                                                                                                                                                                                                                                                                       |
|--------------|-----------|-------------------------------------------------------------------------------------------------------------------------------------------------------------------------------------------------------------------------------------------------------------------------------------------------------------------------------------------------------------------------------------------------------------------------------------------------------------------------------------------------------------------------------------------------------------------------------------------------------------------------------------------------------------------------------------------------------------------------------------------------------------------------------------------------------------------------------------------------------------------------------------------------------------------------------------------------------------------------------------------------------------------------------------------------------------------------------------------------------------------------------------------------------------------------------------------------------------------------------------------------------------------------------------------------------------------------------------------------------------------------------------------------------------------------------------------------------------------------------------------------------------------------------------------------------------------------------------------------------------------------------------------------------------------------------------------------------------------------------------------------------------------|
| Impact Flags | bits[8]   | <p>Impact flag value of the event. The low-order eight bits indicate the impact level. Values are:</p> <ul style="list-style-type: none"> <li>0x01 (bit 0) - Source or destination host is in a network monitored by the system.</li> <li>0x02 (bit 1) - Source or destination host exists in the network map.</li> <li>0x04 (bit 2) - Source or destination host is running a server on the port in the event (if TCP or UDP) or uses the IP protocol.</li> <li>0x08 (bit 3) - There is a vulnerability mapped to the operating system of the source or destination host in the event.</li> <li>0x10 (bit 4) - There is a vulnerability mapped to the server detected in the event.</li> <li>0x20 (bit 5) - The event caused the managed device to drop the session (used only when the device is running in inline, switched, or routed deployment). Corresponds to blocked status in the FireSIGHT System web interface.</li> <li>0x40 (bit 6) - The rule that generated this event contains rule metadata setting the impact flag to red. The source or destination host is potentially compromised by a virus, trojan, or other piece of malicious software.</li> <li>0x80 (bit 7) - There is a vulnerability mapped to the client detected in the event. (version 5.0+ only)</li> </ul> <p>The following impact level values map to specific priorities on the Defense Center. An x indicates the value can be 0 or 1:</p> <ul style="list-style-type: none"> <li>gray (0, unknown): 00X00000</li> <li>red (1, vulnerable): XXXX1XXX, XXX1XXXX, X1XXXXXX, 1XXXXXXX (version 5.0+ only)</li> <li>orange (2, potentially vulnerable): 00X0011X</li> <li>yellow (3, currently not vulnerable): 00X0001X</li> <li>blue (4, unknown target): 00X00001</li> </ul> |
| Impact       | uint8     | <p>Impact flag value of the event. Values are:</p> <ul style="list-style-type: none"> <li>1 - Red (vulnerable)</li> <li>2 - Orange (potentially vulnerable)</li> <li>3 - Yellow (currently not vulnerable)</li> <li>4 - Blue (unknown target)</li> <li>5 - Gray (unknown impact)</li> </ul>                                                                                                                                                                                                                                                                                                                                                                                                                                                                                                                                                                                                                                                                                                                                                                                                                                                                                                                                                                                                                                                                                                                                                                                                                                                                                                                                                                                                                                                                       |
| Blocked      | uint8     | <p>Value indicating whether the event was blocked:</p> <ul style="list-style-type: none"> <li>0 - not blocked</li> <li>1 - blocked</li> <li>2 - would be blocked (but not permitted by configuration)</li> </ul>                                                                                                                                                                                                                                                                                                                                                                                                                                                                                                                                                                                                                                                                                                                                                                                                                                                                                                                                                                                                                                                                                                                                                                                                                                                                                                                                                                                                                                                                                                                                                  |

Table B-4 Intrusion Event Record 5.3 Fields (continued)

| Field                      | Data Type | Description                                                                                            |
|----------------------------|-----------|--------------------------------------------------------------------------------------------------------|
| MPLS Label                 | uint32    | MPLS label.                                                                                            |
| VLAN ID                    | uint16    | Indicates the ID of the VLAN where the packet originated.                                              |
| Pad                        | uint16    | Reserved for future use.                                                                               |
| Policy UUID                | uint8[16] | A policy ID number that acts as a unique identifier for the intrusion policy.                          |
| User ID                    | uint32    | The internal identification number for the user, if applicable.                                        |
| Web Application ID         | uint32    | The internal identification number for the web application, if applicable.                             |
| Client Application ID      | uint32    | The internal identification number for the client application, if applicable.                          |
| Application Protocol ID    | uint32    | The internal identification number for the application protocol, if applicable.                        |
| Access Control Rule ID     | uint32    | A rule ID number that acts as a unique identifier for the access control rule.                         |
| Access Control Policy UUID | uint8[16] | A policy ID number that acts as a unique identifier for the access control policy.                     |
| Ingress Interface UUID     | uint8[16] | An interface ID number that acts as a unique identifier for the ingress interface.                     |
| Egress Interface UUID      | uint8[16] | An interface ID number that acts as a unique identifier for the egress interface.                      |
| Ingress Security Zone UUID | uint8[16] | A zone ID number that acts as a unique identifier for the ingress security zone.                       |
| Egress Security Zone UUID  | uint8[16] | A zone ID number that acts as a unique identifier for the egress security zone.                        |
| Connection Timestamp       | uint32    | UNIX timestamp (seconds since 01/01/1970) of the connection event associated with the intrusion event. |
| Connection Instance ID     | uint16    | Numerical ID of the Snort instance on the managed device that generated the connection event.          |
| Connection Counter         | uint16    | Value used to distinguish between connection events that happen during the same second.                |
| Source Country             | uint16    | Code for the country of the source host.                                                               |
| Destination Country        | uint16    | Code for the country of the destination host.                                                          |
| IOC Number                 | uint16    | ID Number of the compromise associated with this event.                                                |

## Intrusion Event Record 5.1.1.x

The fields in the intrusion event record are shaded in the following graphic. The record type is 400 and the block type is 25.

You can request 5.1.1.x intrusion events from eStreamer only by extended request, for which you request event type code 12 and version code 4 in the Stream Request message (see [Submitting Extended Requests, page 2-4](#) for information about submitting extended requests).

For version 5.1.1.x intrusion events, the event ID, the managed device ID, and the event second form a unique identifier. The connection second, connection instance, and connection counter together form a unique identifier for the connection event associated with the intrusion event.

|      |                                                               |   |   |   |   |   |   |   |   |   |    |    |    |    |    |    |                  |    |    |    |    |    |    |    |    |    |    |    |    |    |    |    |
|------|---------------------------------------------------------------|---|---|---|---|---|---|---|---|---|----|----|----|----|----|----|------------------|----|----|----|----|----|----|----|----|----|----|----|----|----|----|----|
| Byte | 0                                                             |   |   |   |   |   |   |   | 1 |   |    |    |    |    |    |    | 2                |    |    |    |    |    |    |    | 3  |    |    |    |    |    |    |    |
| Bit  | 0                                                             | 1 | 2 | 3 | 4 | 5 | 6 | 7 | 8 | 9 | 10 | 11 | 12 | 13 | 14 | 15 | 16               | 17 | 18 | 19 | 20 | 21 | 22 | 23 | 24 | 25 | 26 | 27 | 28 | 29 | 30 | 31 |
|      | Header Version (1)                                            |   |   |   |   |   |   |   |   |   |    |    |    |    |    |    | Message Type (4) |    |    |    |    |    |    |    |    |    |    |    |    |    |    |    |
|      | Message Length                                                |   |   |   |   |   |   |   |   |   |    |    |    |    |    |    |                  |    |    |    |    |    |    |    |    |    |    |    |    |    |    |    |
|      | Record Type (400)                                             |   |   |   |   |   |   |   |   |   |    |    |    |    |    |    |                  |    |    |    |    |    |    |    |    |    |    |    |    |    |    |    |
|      | Record Length                                                 |   |   |   |   |   |   |   |   |   |    |    |    |    |    |    |                  |    |    |    |    |    |    |    |    |    |    |    |    |    |    |    |
|      | eStreamer Server Timestamp (in events, only if bit 23 is set) |   |   |   |   |   |   |   |   |   |    |    |    |    |    |    |                  |    |    |    |    |    |    |    |    |    |    |    |    |    |    |    |
|      | Reserved for Future Use (in events, only if bit 23 is set)    |   |   |   |   |   |   |   |   |   |    |    |    |    |    |    |                  |    |    |    |    |    |    |    |    |    |    |    |    |    |    |    |
|      | Block Type (25)                                               |   |   |   |   |   |   |   |   |   |    |    |    |    |    |    |                  |    |    |    |    |    |    |    |    |    |    |    |    |    |    |    |
|      | Block Length                                                  |   |   |   |   |   |   |   |   |   |    |    |    |    |    |    |                  |    |    |    |    |    |    |    |    |    |    |    |    |    |    |    |
|      | Device ID                                                     |   |   |   |   |   |   |   |   |   |    |    |    |    |    |    |                  |    |    |    |    |    |    |    |    |    |    |    |    |    |    |    |
|      | Event ID                                                      |   |   |   |   |   |   |   |   |   |    |    |    |    |    |    |                  |    |    |    |    |    |    |    |    |    |    |    |    |    |    |    |
|      | Event Second                                                  |   |   |   |   |   |   |   |   |   |    |    |    |    |    |    |                  |    |    |    |    |    |    |    |    |    |    |    |    |    |    |    |
|      | Event Microsecond                                             |   |   |   |   |   |   |   |   |   |    |    |    |    |    |    |                  |    |    |    |    |    |    |    |    |    |    |    |    |    |    |    |
|      | Rule ID (Signature ID)                                        |   |   |   |   |   |   |   |   |   |    |    |    |    |    |    |                  |    |    |    |    |    |    |    |    |    |    |    |    |    |    |    |
|      | Generator ID                                                  |   |   |   |   |   |   |   |   |   |    |    |    |    |    |    |                  |    |    |    |    |    |    |    |    |    |    |    |    |    |    |    |
|      | Rule Revision                                                 |   |   |   |   |   |   |   |   |   |    |    |    |    |    |    |                  |    |    |    |    |    |    |    |    |    |    |    |    |    |    |    |
|      | Classification ID                                             |   |   |   |   |   |   |   |   |   |    |    |    |    |    |    |                  |    |    |    |    |    |    |    |    |    |    |    |    |    |    |    |
|      | Priority ID                                                   |   |   |   |   |   |   |   |   |   |    |    |    |    |    |    |                  |    |    |    |    |    |    |    |    |    |    |    |    |    |    |    |



|          |                                       |   |   |   |   |   |   |   |              |   |    |    |    |    |    |    |                            |    |    |    |    |    |    |    |         |    |    |    |    |    |    |    |
|----------|---------------------------------------|---|---|---|---|---|---|---|--------------|---|----|----|----|----|----|----|----------------------------|----|----|----|----|----|----|----|---------|----|----|----|----|----|----|----|
| By<br>te | 0                                     |   |   |   |   |   |   |   | 1            |   |    |    |    |    |    |    | 2                          |    |    |    |    |    |    |    | 3       |    |    |    |    |    |    |    |
|          | 0                                     | 1 | 2 | 3 | 4 | 5 | 6 | 7 | 8            | 9 | 10 | 11 | 12 | 13 | 14 | 15 | 16                         | 17 | 18 | 19 | 20 | 21 | 22 | 23 | 24      | 25 | 26 | 27 | 28 | 29 | 30 | 31 |
| Bit      | Source IP Address                     |   |   |   |   |   |   |   |              |   |    |    |    |    |    |    |                            |    |    |    |    |    |    |    |         |    |    |    |    |    |    |    |
|          | Source IP Address, continued          |   |   |   |   |   |   |   |              |   |    |    |    |    |    |    |                            |    |    |    |    |    |    |    |         |    |    |    |    |    |    |    |
|          | Source IP Address, continued          |   |   |   |   |   |   |   |              |   |    |    |    |    |    |    |                            |    |    |    |    |    |    |    |         |    |    |    |    |    |    |    |
|          | Source IP Address, continued          |   |   |   |   |   |   |   |              |   |    |    |    |    |    |    |                            |    |    |    |    |    |    |    |         |    |    |    |    |    |    |    |
|          | Destination IP Address                |   |   |   |   |   |   |   |              |   |    |    |    |    |    |    |                            |    |    |    |    |    |    |    |         |    |    |    |    |    |    |    |
|          | Destination IP Address, continued     |   |   |   |   |   |   |   |              |   |    |    |    |    |    |    |                            |    |    |    |    |    |    |    |         |    |    |    |    |    |    |    |
|          | Destination IP Address, continued     |   |   |   |   |   |   |   |              |   |    |    |    |    |    |    |                            |    |    |    |    |    |    |    |         |    |    |    |    |    |    |    |
|          | Destination IP Address, continued     |   |   |   |   |   |   |   |              |   |    |    |    |    |    |    |                            |    |    |    |    |    |    |    |         |    |    |    |    |    |    |    |
|          | Source Port/ICMP Type                 |   |   |   |   |   |   |   |              |   |    |    |    |    |    |    | Destination Port/ICMP Code |    |    |    |    |    |    |    |         |    |    |    |    |    |    |    |
|          | IP Protocol ID                        |   |   |   |   |   |   |   | Impact Flags |   |    |    |    |    |    |    | Impact                     |    |    |    |    |    |    |    | Blocked |    |    |    |    |    |    |    |
|          | MPLS Label                            |   |   |   |   |   |   |   |              |   |    |    |    |    |    |    |                            |    |    |    |    |    |    |    |         |    |    |    |    |    |    |    |
|          | VLAN ID                               |   |   |   |   |   |   |   |              |   |    |    |    |    |    |    | Pad                        |    |    |    |    |    |    |    |         |    |    |    |    |    |    |    |
|          | Policy UUID                           |   |   |   |   |   |   |   |              |   |    |    |    |    |    |    |                            |    |    |    |    |    |    |    |         |    |    |    |    |    |    |    |
|          | Policy UUID, continued                |   |   |   |   |   |   |   |              |   |    |    |    |    |    |    |                            |    |    |    |    |    |    |    |         |    |    |    |    |    |    |    |
|          | Policy UUID, continued                |   |   |   |   |   |   |   |              |   |    |    |    |    |    |    |                            |    |    |    |    |    |    |    |         |    |    |    |    |    |    |    |
|          | Policy UUID, continued                |   |   |   |   |   |   |   |              |   |    |    |    |    |    |    |                            |    |    |    |    |    |    |    |         |    |    |    |    |    |    |    |
|          | User ID                               |   |   |   |   |   |   |   |              |   |    |    |    |    |    |    |                            |    |    |    |    |    |    |    |         |    |    |    |    |    |    |    |
|          | Web Application ID                    |   |   |   |   |   |   |   |              |   |    |    |    |    |    |    |                            |    |    |    |    |    |    |    |         |    |    |    |    |    |    |    |
|          | Client Application ID                 |   |   |   |   |   |   |   |              |   |    |    |    |    |    |    |                            |    |    |    |    |    |    |    |         |    |    |    |    |    |    |    |
|          | Application Protocol ID               |   |   |   |   |   |   |   |              |   |    |    |    |    |    |    |                            |    |    |    |    |    |    |    |         |    |    |    |    |    |    |    |
|          | Access Control Rule ID                |   |   |   |   |   |   |   |              |   |    |    |    |    |    |    |                            |    |    |    |    |    |    |    |         |    |    |    |    |    |    |    |
|          | Access Control Policy UUID            |   |   |   |   |   |   |   |              |   |    |    |    |    |    |    |                            |    |    |    |    |    |    |    |         |    |    |    |    |    |    |    |
|          | Access Control Policy UUID, continued |   |   |   |   |   |   |   |              |   |    |    |    |    |    |    |                            |    |    |    |    |    |    |    |         |    |    |    |    |    |    |    |
|          | Access Control Policy UUID, continued |   |   |   |   |   |   |   |              |   |    |    |    |    |    |    |                            |    |    |    |    |    |    |    |         |    |    |    |    |    |    |    |
|          | Access Control Policy UUID, continued |   |   |   |   |   |   |   |              |   |    |    |    |    |    |    |                            |    |    |    |    |    |    |    |         |    |    |    |    |    |    |    |

|                                       |                                   |   |   |   |   |   |   |   |   |   |   |   |   |   |   |                    |   |   |   |   |   |   |   |   |   |   |   |   |   |   |   |   |   |   |   |   |   |
|---------------------------------------|-----------------------------------|---|---|---|---|---|---|---|---|---|---|---|---|---|---|--------------------|---|---|---|---|---|---|---|---|---|---|---|---|---|---|---|---|---|---|---|---|---|
| By<br>te                              | 0                                 |   |   |   |   |   |   |   | 1 |   |   |   |   |   |   |                    | 2 |   |   |   |   |   |   |   | 3 |   |   |   |   |   |   |   |   |   |   |   |   |
|                                       | 0                                 | 1 | 2 | 3 | 4 | 5 | 6 | 7 | 8 | 9 | 0 | 1 | 2 | 3 | 4 | 5                  | 6 | 7 | 8 | 9 | 0 | 1 | 2 | 3 | 4 | 5 | 6 | 7 | 8 | 9 | 0 | 1 | 2 | 3 | 4 | 5 | 6 |
| Bit                                   | Interface Ingress UUID            |   |   |   |   |   |   |   |   |   |   |   |   |   |   |                    |   |   |   |   |   |   |   |   |   |   |   |   |   |   |   |   |   |   |   |   |   |
|                                       | Interface Ingress UUID, continued |   |   |   |   |   |   |   |   |   |   |   |   |   |   |                    |   |   |   |   |   |   |   |   |   |   |   |   |   |   |   |   |   |   |   |   |   |
| Interface Ingress UUID, continued     |                                   |   |   |   |   |   |   |   |   |   |   |   |   |   |   |                    |   |   |   |   |   |   |   |   |   |   |   |   |   |   |   |   |   |   |   |   |   |
| Interface Ingress UUID, continued     |                                   |   |   |   |   |   |   |   |   |   |   |   |   |   |   |                    |   |   |   |   |   |   |   |   |   |   |   |   |   |   |   |   |   |   |   |   |   |
| Interface Egress UUID                 |                                   |   |   |   |   |   |   |   |   |   |   |   |   |   |   |                    |   |   |   |   |   |   |   |   |   |   |   |   |   |   |   |   |   |   |   |   |   |
| Interface Egress UUID, continued      |                                   |   |   |   |   |   |   |   |   |   |   |   |   |   |   |                    |   |   |   |   |   |   |   |   |   |   |   |   |   |   |   |   |   |   |   |   |   |
| Interface Egress UUID, continued      |                                   |   |   |   |   |   |   |   |   |   |   |   |   |   |   |                    |   |   |   |   |   |   |   |   |   |   |   |   |   |   |   |   |   |   |   |   |   |
| Interface Egress UUID, continued      |                                   |   |   |   |   |   |   |   |   |   |   |   |   |   |   |                    |   |   |   |   |   |   |   |   |   |   |   |   |   |   |   |   |   |   |   |   |   |
| Security Zone Ingress UUID            |                                   |   |   |   |   |   |   |   |   |   |   |   |   |   |   |                    |   |   |   |   |   |   |   |   |   |   |   |   |   |   |   |   |   |   |   |   |   |
| Security Zone Ingress UUID, continued |                                   |   |   |   |   |   |   |   |   |   |   |   |   |   |   |                    |   |   |   |   |   |   |   |   |   |   |   |   |   |   |   |   |   |   |   |   |   |
| Security Zone Ingress UUID, continued |                                   |   |   |   |   |   |   |   |   |   |   |   |   |   |   |                    |   |   |   |   |   |   |   |   |   |   |   |   |   |   |   |   |   |   |   |   |   |
| Security Zone Ingress UUID, continued |                                   |   |   |   |   |   |   |   |   |   |   |   |   |   |   |                    |   |   |   |   |   |   |   |   |   |   |   |   |   |   |   |   |   |   |   |   |   |
| Security Zone Egress UUID             |                                   |   |   |   |   |   |   |   |   |   |   |   |   |   |   |                    |   |   |   |   |   |   |   |   |   |   |   |   |   |   |   |   |   |   |   |   |   |
| Security Zone Egress UUID, continued  |                                   |   |   |   |   |   |   |   |   |   |   |   |   |   |   |                    |   |   |   |   |   |   |   |   |   |   |   |   |   |   |   |   |   |   |   |   |   |
| Security Zone Egress UUID, continued  |                                   |   |   |   |   |   |   |   |   |   |   |   |   |   |   |                    |   |   |   |   |   |   |   |   |   |   |   |   |   |   |   |   |   |   |   |   |   |
| Security Zone Egress UUID, continued  |                                   |   |   |   |   |   |   |   |   |   |   |   |   |   |   |                    |   |   |   |   |   |   |   |   |   |   |   |   |   |   |   |   |   |   |   |   |   |
| Connection Timestamp                  |                                   |   |   |   |   |   |   |   |   |   |   |   |   |   |   |                    |   |   |   |   |   |   |   |   |   |   |   |   |   |   |   |   |   |   |   |   |   |
| Connection Instance ID                |                                   |   |   |   |   |   |   |   |   |   |   |   |   |   |   | Connection Counter |   |   |   |   |   |   |   |   |   |   |   |   |   |   |   |   |   |   |   |   |   |

The following table describes each intrusion event record data field.

**Table B-5** *Intrusion Event Record 5.1.1 Fields*

| Field        | Data Type | Description                                                                                                                                                                         |
|--------------|-----------|-------------------------------------------------------------------------------------------------------------------------------------------------------------------------------------|
| Block Type   | uint32    | Initiates an Intrusion Event data block. This value is always 25.                                                                                                                   |
| Block Length | uint32    | Total number of bytes in the Intrusion Event data block, including eight bytes for the Intrusion Event block type and length fields, plus the number of bytes of data that follows. |

Table B-5 Intrusion Event Record 5.1.1 Fields (continued)

| Field                      | Data Type | Description                                                                                                                                                                                                                            |
|----------------------------|-----------|----------------------------------------------------------------------------------------------------------------------------------------------------------------------------------------------------------------------------------------|
| Device ID                  | uint32    | Contains the identification number of the detecting managed device. You can obtain the managed device name by requesting Version 3 or 4 metadata. See <a href="#">Managed Device Record Metadata</a> , page 3-30 for more information. |
| Event ID                   | uint32    | Event identification number.                                                                                                                                                                                                           |
| Event Second               | uint32    | UNIX timestamp (seconds since 01/01/1970) of the event's detection.                                                                                                                                                                    |
| Event Microsecond          | uint32    | Microsecond (one millionth of a second) increment of the timestamp of the event's detection.                                                                                                                                           |
| Rule ID (Signature ID)     | uint32    | Rule identification number that corresponds with the event.                                                                                                                                                                            |
| Generator ID               | uint32    | Identification number of the FireSIGHT System preprocessor that generated the event.                                                                                                                                                   |
| Rule Revision              | uint32    | Rule revision number.                                                                                                                                                                                                                  |
| Classification ID          | uint32    | Identification number of the event classification message.                                                                                                                                                                             |
| Priority ID                | uint32    | Identification number of the priority associated with the event.                                                                                                                                                                       |
| Source IP Address          | uint8[16] | Source IPv4 or IPv6 address used in the event.                                                                                                                                                                                         |
| Destination IP Address     | uint8[16] | Destination IPv4 or IPv6 address used in the event.                                                                                                                                                                                    |
| Source Port/ICMP Type      | uint16    | The source port number if the event protocol type is TCP or UDP, or the ICMP type if the event is caused by ICMP traffic.                                                                                                              |
| Destination Port/ICMP Code | uint16    | The destination port number if the event protocol type is TCP or UDP, or the ICMP code if the event is caused by ICMP traffic.                                                                                                         |
| IP Protocol Number         | uint8     | IANA-specified protocol number. For example: <ul style="list-style-type: none"> <li>• 0 - IP</li> <li>• 1 - ICMP</li> <li>• 6 - TCP</li> <li>• 17 - UDP</li> </ul>                                                                     |

Table B-5 Intrusion Event Record 5.1.1 Fields (continued)

| Field        | Data Type | Description                                                                                                                                                                                                                                                                                                                                                                                                                                                                                                                                                                                                                                                                                                                                                                                                                                                                                                                                                                                                                                                                                                                                                                                                                                                                                                                                                                                                                                                                                                                                                                                                                                                                                                               |
|--------------|-----------|---------------------------------------------------------------------------------------------------------------------------------------------------------------------------------------------------------------------------------------------------------------------------------------------------------------------------------------------------------------------------------------------------------------------------------------------------------------------------------------------------------------------------------------------------------------------------------------------------------------------------------------------------------------------------------------------------------------------------------------------------------------------------------------------------------------------------------------------------------------------------------------------------------------------------------------------------------------------------------------------------------------------------------------------------------------------------------------------------------------------------------------------------------------------------------------------------------------------------------------------------------------------------------------------------------------------------------------------------------------------------------------------------------------------------------------------------------------------------------------------------------------------------------------------------------------------------------------------------------------------------------------------------------------------------------------------------------------------------|
| Impact Flags | bits[8]   | <p>Impact flag value of the event. The low-order eight bits indicate the impact level. Values are:</p> <ul style="list-style-type: none"> <li>0x01 (bit 0) - Source or destination host is in a network monitored by the system.</li> <li>0x02 (bit 1) - Source or destination host exists in the network map.</li> <li>0x04 (bit 2) - Source or destination host is running a server on the port in the event (if TCP or UDP) or uses the IP protocol.</li> <li>0x08 (bit 3) - There is a vulnerability mapped to the operating system of the source or destination host in the event.</li> <li>0x10 (bit 4) - There is a vulnerability mapped to the server detected in the event.</li> <li>0x20 (bit 5) - The event caused the managed device to drop the session (used only when the device is running in inline, switched, or routed deployment). Corresponds to blocked status in the FireSIGHT System web interface.</li> <li>0x40 (bit 6) - The rule that generated this event contains rule metadata setting the impact flag to red. The source or destination host is potentially compromised by a virus, trojan, or other piece of malicious software.</li> <li>0x80 (bit 7) - There is a vulnerability mapped to the client detected in the event.</li> </ul> <p>The following impact level values map to specific priorities on the Defense Center. An x indicates the value can be 0 or 1:</p> <ul style="list-style-type: none"> <li>gray (0, unknown): 00X00000</li> <li>red (1, vulnerable): XXXX1XXX, XXX1XXXX, X1XXXXXX, 1XXXXXXX</li> <li>orange (2, potentially vulnerable): 00X00111</li> <li>yellow (3, currently not vulnerable): 00X00011</li> <li>blue (4, unknown target): 00X00001</li> </ul> |
| Impact       | uint8     | <p>Impact flag value of the event. Values are:</p> <ul style="list-style-type: none"> <li>1 - Red (vulnerable)</li> <li>2 - Orange (potentially vulnerable)</li> <li>3 - Yellow (currently not vulnerable)</li> <li>4 - Blue (unknown target)</li> <li>5 - Gray (unknown impact)</li> </ul>                                                                                                                                                                                                                                                                                                                                                                                                                                                                                                                                                                                                                                                                                                                                                                                                                                                                                                                                                                                                                                                                                                                                                                                                                                                                                                                                                                                                                               |
| Blocked      | uint8     | <p>Value indicating whether the event was blocked:</p> <ul style="list-style-type: none"> <li>0 - not blocked</li> <li>1 - blocked</li> <li>2 - would be blocked (but not permitted by configuration)</li> </ul>                                                                                                                                                                                                                                                                                                                                                                                                                                                                                                                                                                                                                                                                                                                                                                                                                                                                                                                                                                                                                                                                                                                                                                                                                                                                                                                                                                                                                                                                                                          |
| MPLS Label   | uint32    | MPLS label.                                                                                                                                                                                                                                                                                                                                                                                                                                                                                                                                                                                                                                                                                                                                                                                                                                                                                                                                                                                                                                                                                                                                                                                                                                                                                                                                                                                                                                                                                                                                                                                                                                                                                                               |

**Table B-5** *Intrusion Event Record 5.1.1 Fields (continued)*

| Field                      | Data Type | Description                                                                                            |
|----------------------------|-----------|--------------------------------------------------------------------------------------------------------|
| VLAN ID                    | uint16    | Indicates the ID of the VLAN where the packet originated.                                              |
| Pad                        | uint16    | Reserved for future use.                                                                               |
| Policy UUID                | uint8[16] | A policy ID number that acts as a unique identifier for the intrusion policy.                          |
| User ID                    | uint32    | The internal identification number for the user, if applicable.                                        |
| Web Application ID         | uint32    | The internal identification number for the web application, if applicable.                             |
| Client Application ID      | uint32    | The internal identification number for the client application, if applicable.                          |
| Application Protocol ID    | uint32    | The internal identification number for the application protocol, if applicable.                        |
| Access Control Rule ID     | uint32    | A rule ID number that acts as a unique identifier for the access control rule.                         |
| Access Control Policy UUID | uint8[16] | A policy ID number that acts as a unique identifier for the access control policy.                     |
| Ingress Interface UUID     | uint8[16] | An interface ID number that acts as a unique identifier for the ingress interface.                     |
| Egress Interface UUID      | uint8[16] | An interface ID number that acts as a unique identifier for the egress interface.                      |
| Ingress Security Zone UUID | uint8[16] | A zone ID number that acts as a unique identifier for the ingress security zone.                       |
| Egress Security Zone UUID  | uint8[16] | A zone ID number that acts as a unique identifier for the egress security zone.                        |
| Connection Timestamp       | uint32    | UNIX timestamp (seconds since 01/01/1970) of the connection event associated with the intrusion event. |
| Connection Instance ID     | uint16    | Numerical ID of the Snort instance on the managed device that generated the connection event.          |
| Connection Counter         | uint16    | Value used to distinguish between connection events that happen during the same second.                |

## Intrusion Impact Alert Data

The Intrusion Impact Alert event contains information about impact events. It is transmitted when an intrusion event is compared to the system network map data and the impact is determined. It uses the standard record header with a record type of 9, followed by an Intrusion Impact Alert data block with a data block type of 20 in the series 1 group of blocks. (The Impact Alert data block is a type of series 1 data block. For more information about series 1 data blocks, see [Understanding Discovery \(Series 1\) Blocks, page 4-55.](#))

You can request that eStreamer only transmit intrusion impact events by setting bit 5 in the Flags field of the request message. See [Event Stream Request Message Format, page 2-10](#) for more information about request messages. Version 1 of these alerts only handles IPv4. Version 2, introduced in 5.3, handles IPv6 events in addition to IPv4.

|                    |                                        |   |   |   |   |   |   |   |   |   |    |    |    |    |    |    |                  |    |    |    |    |    |    |    |    |    |    |    |    |    |    |    |
|--------------------|----------------------------------------|---|---|---|---|---|---|---|---|---|----|----|----|----|----|----|------------------|----|----|----|----|----|----|----|----|----|----|----|----|----|----|----|
| Byte               | 0                                      |   |   |   |   |   |   |   | 1 |   |    |    |    |    |    |    | 2                |    |    |    |    |    |    |    | 3  |    |    |    |    |    |    |    |
| Bit                | 0                                      | 1 | 2 | 3 | 4 | 5 | 6 | 7 | 8 | 9 | 10 | 11 | 12 | 13 | 14 | 15 | 16               | 17 | 18 | 19 | 20 | 21 | 22 | 23 | 24 | 25 | 26 | 27 | 28 | 29 | 30 | 31 |
|                    | Header Version (1)                     |   |   |   |   |   |   |   |   |   |    |    |    |    |    |    | Message Type (4) |    |    |    |    |    |    |    |    |    |    |    |    |    |    |    |
|                    | Message Length                         |   |   |   |   |   |   |   |   |   |    |    |    |    |    |    |                  |    |    |    |    |    |    |    |    |    |    |    |    |    |    |    |
|                    | Record Type (9)                        |   |   |   |   |   |   |   |   |   |    |    |    |    |    |    |                  |    |    |    |    |    |    |    |    |    |    |    |    |    |    |    |
|                    | Record Length                          |   |   |   |   |   |   |   |   |   |    |    |    |    |    |    |                  |    |    |    |    |    |    |    |    |    |    |    |    |    |    |    |
|                    | Intrusion Impact Alert Block Type (20) |   |   |   |   |   |   |   |   |   |    |    |    |    |    |    |                  |    |    |    |    |    |    |    |    |    |    |    |    |    |    |    |
|                    | Intrusion Impact Alert Block Length    |   |   |   |   |   |   |   |   |   |    |    |    |    |    |    |                  |    |    |    |    |    |    |    |    |    |    |    |    |    |    |    |
|                    | Event ID                               |   |   |   |   |   |   |   |   |   |    |    |    |    |    |    |                  |    |    |    |    |    |    |    |    |    |    |    |    |    |    |    |
|                    | Device ID                              |   |   |   |   |   |   |   |   |   |    |    |    |    |    |    |                  |    |    |    |    |    |    |    |    |    |    |    |    |    |    |    |
|                    | Event Second                           |   |   |   |   |   |   |   |   |   |    |    |    |    |    |    |                  |    |    |    |    |    |    |    |    |    |    |    |    |    |    |    |
|                    | Impact                                 |   |   |   |   |   |   |   |   |   |    |    |    |    |    |    |                  |    |    |    |    |    |    |    |    |    |    |    |    |    |    |    |
|                    | Source IP Address                      |   |   |   |   |   |   |   |   |   |    |    |    |    |    |    |                  |    |    |    |    |    |    |    |    |    |    |    |    |    |    |    |
|                    | Destination IP Address                 |   |   |   |   |   |   |   |   |   |    |    |    |    |    |    |                  |    |    |    |    |    |    |    |    |    |    |    |    |    |    |    |
| Impact Description | String Block Type (0)                  |   |   |   |   |   |   |   |   |   |    |    |    |    |    |    |                  |    |    |    |    |    |    |    |    |    |    |    |    |    |    |    |
|                    | String Block Length                    |   |   |   |   |   |   |   |   |   |    |    |    |    |    |    |                  |    |    |    |    |    |    |    |    |    |    |    |    |    |    |    |
|                    | Description...                         |   |   |   |   |   |   |   |   |   |    |    |    |    |    |    |                  |    |    |    |    |    |    |    |    |    |    |    |    |    |    |    |

The following table describes each data field in an impact event.

**Table B-6** *Impact Event Data Fields*

| Field                               | Data Type | Description                                                                                                                                                                       |
|-------------------------------------|-----------|-----------------------------------------------------------------------------------------------------------------------------------------------------------------------------------|
| Intrusion Impact Alert Block Type   | uint32    | Indicates that an intrusion impact alert data block follows. This field will always have a value of 20. See <a href="#">Intrusion Event and Metadata Record Types, page 3-1</a> . |
| Intrusion Impact Alert Block Length | uint32    | Indicates the length of the intrusion impact alert data block, including all data that follows and 8 bytes for the intrusion impact alert block type and length.                  |
| Event ID                            | uint32    | Indicates the event identification number.                                                                                                                                        |
| Device ID                           | uint32    | Indicates the managed device identification number.                                                                                                                               |
| Event Second                        | uint32    | Indicates the second (from 01/01/1970) that the event was detected.                                                                                                               |

Table B-6 Impact Event Data Fields (continued)

| Field                  | Data Type | Description                                                                                                                                                                                                                                                                                                                                                                                                                                                                                                                                                                                                                                                                                                                                                                                                                                                                                                                                                                                                                                                                                                                                                                                                                                                                                                                                                                                                                                                                                                                                                                                                                                                                                                                                                       |
|------------------------|-----------|-------------------------------------------------------------------------------------------------------------------------------------------------------------------------------------------------------------------------------------------------------------------------------------------------------------------------------------------------------------------------------------------------------------------------------------------------------------------------------------------------------------------------------------------------------------------------------------------------------------------------------------------------------------------------------------------------------------------------------------------------------------------------------------------------------------------------------------------------------------------------------------------------------------------------------------------------------------------------------------------------------------------------------------------------------------------------------------------------------------------------------------------------------------------------------------------------------------------------------------------------------------------------------------------------------------------------------------------------------------------------------------------------------------------------------------------------------------------------------------------------------------------------------------------------------------------------------------------------------------------------------------------------------------------------------------------------------------------------------------------------------------------|
| Impact                 | bits[8]   | <p>Impact flag value of the event. The low-order eight bits indicate the impact level. Values are:</p> <ul style="list-style-type: none"> <li>0x01 (bit 0) - Source or destination host is in a network monitored by the system.</li> <li>0x02 (bit 1) - Source or destination host exists in the network map.</li> <li>0x04 (bit 2) - Source or destination host is running a server on the port in the event (if TCP or UDP) or uses the IP protocol.</li> <li>0x08 (bit 3) - There is a vulnerability mapped to the operating system of the source or destination host in the event.</li> <li>0x10 (bit 4) - There is a vulnerability mapped to the server detected in the event.</li> <li>0x20 (bit 5) - The event caused the managed device to drop the session (used only when the device is running in inline, switched, or routed deployment). Corresponds to blocked status in the FireSIGHT System web interface.</li> <li>0x40 (bit 6) - The rule that generated this event contains rule metadata setting the impact flag to red. The source or destination host is potentially compromised by a virus, trojan, or other piece of malicious software.</li> <li>0x80 (bit 7) - There is a vulnerability mapped to the client detected in the event. (version 5.0+ only)</li> </ul> <p>The following impact level values map to specific priorities on the Defense Center. An x indicates the value can be 0 or 1:</p> <ul style="list-style-type: none"> <li>gray (0, unknown): 00X00000</li> <li>red (1, vulnerable): XXXX1XXX, XXX1XXXX, X1XXXXXX, 1XXXXXXX (version 5.0+ only)</li> <li>orange (2, potentially vulnerable): 00X0011X</li> <li>yellow (3, currently not vulnerable): 00X0001X</li> <li>blue (4, unknown target): 00X00001</li> </ul> |
| Source IP Address      | uint8[4]  | IP address of the host associated with the impact event, in IP address octets.                                                                                                                                                                                                                                                                                                                                                                                                                                                                                                                                                                                                                                                                                                                                                                                                                                                                                                                                                                                                                                                                                                                                                                                                                                                                                                                                                                                                                                                                                                                                                                                                                                                                                    |
| Destination IP Address | uint8[4]  | IP address of the destination IP address associated with the impact event (if applicable), in IP address octets. This value is 0 if there is no destination IP address.                                                                                                                                                                                                                                                                                                                                                                                                                                                                                                                                                                                                                                                                                                                                                                                                                                                                                                                                                                                                                                                                                                                                                                                                                                                                                                                                                                                                                                                                                                                                                                                           |
| String Block Type      | uint32    | Initiates a string data block that contains the impact name. This value is always set to 0. For more information about string blocks, see <a href="#">String Data Block, page 4-63</a> .                                                                                                                                                                                                                                                                                                                                                                                                                                                                                                                                                                                                                                                                                                                                                                                                                                                                                                                                                                                                                                                                                                                                                                                                                                                                                                                                                                                                                                                                                                                                                                          |
| String Block Length    | uint32    | Number of bytes in the event description string block. This includes the four bytes for the string block type, the four bytes for the string block length, and the number of bytes in the description.                                                                                                                                                                                                                                                                                                                                                                                                                                                                                                                                                                                                                                                                                                                                                                                                                                                                                                                                                                                                                                                                                                                                                                                                                                                                                                                                                                                                                                                                                                                                                            |
| Description            | string    | Description of the impact event.                                                                                                                                                                                                                                                                                                                                                                                                                                                                                                                                                                                                                                                                                                                                                                                                                                                                                                                                                                                                                                                                                                                                                                                                                                                                                                                                                                                                                                                                                                                                                                                                                                                                                                                                  |

# Legacy Malware Event Data Structures

See the following sections for more information:

- [Malware Event Data Block 5.1, page B-32](#)
- [Malware Event Data Block 5.1.1.x, page B-36](#)
- [Malware Event Data Block 5.2.x, page B-42](#)
- [Malware Event Data Block 5.3, page B-48](#)

## Malware Event Data Block 5.1

The eStreamer service uses the malware event data block to store information on malware events. These events contain information on malware detected or quarantined within a cloud, the detection method, and hosts and users affected by the malware. The malware event data block has a block type of 16 in the series 2 group of blocks. You request the event as part of the malware event record by setting the malware event flag—bit 30 in the request flags field—in the request message with an event version of 1 and an event code of 101.

The following graphic shows the structure of the malware event data block:

| Byte                          | 0 |   |   |   |   |   |   |   | 1 |   |    |    |    |    |    |                 | 2  |    |    |    |    |    |    |    | 3  |    |    |    |    |    |    |    |
|-------------------------------|---|---|---|---|---|---|---|---|---|---|----|----|----|----|----|-----------------|----|----|----|----|----|----|----|----|----|----|----|----|----|----|----|----|
| Bit                           | 0 | 1 | 2 | 3 | 4 | 5 | 6 | 7 | 8 | 9 | 10 | 11 | 12 | 13 | 14 | 15              | 16 | 17 | 18 | 19 | 20 | 21 | 22 | 23 | 24 | 25 | 26 | 27 | 28 | 29 | 30 | 31 |
| Malware Event Block Type (16) |   |   |   |   |   |   |   |   |   |   |    |    |    |    |    |                 |    |    |    |    |    |    |    |    |    |    |    |    |    |    |    |    |
| Malware Event Block Length    |   |   |   |   |   |   |   |   |   |   |    |    |    |    |    |                 |    |    |    |    |    |    |    |    |    |    |    |    |    |    |    |    |
| Agent UUID                    |   |   |   |   |   |   |   |   |   |   |    |    |    |    |    |                 |    |    |    |    |    |    |    |    |    |    |    |    |    |    |    |    |
| Agent UUID, continued         |   |   |   |   |   |   |   |   |   |   |    |    |    |    |    |                 |    |    |    |    |    |    |    |    |    |    |    |    |    |    |    |    |
| Agent UUID, continued         |   |   |   |   |   |   |   |   |   |   |    |    |    |    |    |                 |    |    |    |    |    |    |    |    |    |    |    |    |    |    |    |    |
| Agent UUID, continued         |   |   |   |   |   |   |   |   |   |   |    |    |    |    |    |                 |    |    |    |    |    |    |    |    |    |    |    |    |    |    |    |    |
| Cloud UUID                    |   |   |   |   |   |   |   |   |   |   |    |    |    |    |    |                 |    |    |    |    |    |    |    |    |    |    |    |    |    |    |    |    |
| Cloud UUID, continued         |   |   |   |   |   |   |   |   |   |   |    |    |    |    |    |                 |    |    |    |    |    |    |    |    |    |    |    |    |    |    |    |    |
| Cloud UUID, continued         |   |   |   |   |   |   |   |   |   |   |    |    |    |    |    |                 |    |    |    |    |    |    |    |    |    |    |    |    |    |    |    |    |
| Cloud UUID, continued         |   |   |   |   |   |   |   |   |   |   |    |    |    |    |    |                 |    |    |    |    |    |    |    |    |    |    |    |    |    |    |    |    |
| Timestamp                     |   |   |   |   |   |   |   |   |   |   |    |    |    |    |    |                 |    |    |    |    |    |    |    |    |    |    |    |    |    |    |    |    |
| Event Type ID                 |   |   |   |   |   |   |   |   |   |   |    |    |    |    |    |                 |    |    |    |    |    |    |    |    |    |    |    |    |    |    |    |    |
| Event Subtype ID              |   |   |   |   |   |   |   |   |   |   |    |    |    |    |    | Host IP Address |    |    |    |    |    |    |    |    |    |    |    |    |    |    |    |    |



| Byte                 | 0                            |   |   |   |   |   |   |   | 1                     |   |    |    |    |    |    |                | 2                     |    |    |    |    |    |    |    | 3  |    |    |    |    |    |    |    |
|----------------------|------------------------------|---|---|---|---|---|---|---|-----------------------|---|----|----|----|----|----|----------------|-----------------------|----|----|----|----|----|----|----|----|----|----|----|----|----|----|----|
|                      | 0                            | 1 | 2 | 3 | 4 | 5 | 6 | 7 | 8                     | 9 | 10 | 11 | 12 | 13 | 14 | 15             | 16                    | 17 | 18 | 19 | 20 | 21 | 22 | 23 | 24 | 25 | 26 | 27 | 28 | 29 | 30 | 31 |
| Detection Name       | Host IP Address, cont.       |   |   |   |   |   |   |   | Detector ID           |   |    |    |    |    |    |                | String Block Type (0) |    |    |    |    |    |    |    |    |    |    |    |    |    |    |    |
|                      | String Block Type (0), cont. |   |   |   |   |   |   |   |                       |   |    |    |    |    |    |                | String Block Length   |    |    |    |    |    |    |    |    |    |    |    |    |    |    |    |
|                      | String Block Length, cont.   |   |   |   |   |   |   |   |                       |   |    |    |    |    |    |                | Detection Name...     |    |    |    |    |    |    |    |    |    |    |    |    |    |    |    |
| User                 | String Block Type (0)        |   |   |   |   |   |   |   |                       |   |    |    |    |    |    |                |                       |    |    |    |    |    |    |    |    |    |    |    |    |    |    |    |
|                      | String Block Length          |   |   |   |   |   |   |   |                       |   |    |    |    |    |    |                |                       |    |    |    |    |    |    |    |    |    |    |    |    |    |    |    |
|                      | User...                      |   |   |   |   |   |   |   |                       |   |    |    |    |    |    |                |                       |    |    |    |    |    |    |    |    |    |    |    |    |    |    |    |
| File Name            | String Block Type (0)        |   |   |   |   |   |   |   |                       |   |    |    |    |    |    |                |                       |    |    |    |    |    |    |    |    |    |    |    |    |    |    |    |
|                      | String Block Length          |   |   |   |   |   |   |   |                       |   |    |    |    |    |    |                |                       |    |    |    |    |    |    |    |    |    |    |    |    |    |    |    |
|                      | File Name...                 |   |   |   |   |   |   |   |                       |   |    |    |    |    |    |                |                       |    |    |    |    |    |    |    |    |    |    |    |    |    |    |    |
| File Path            | String Block Type (0)        |   |   |   |   |   |   |   |                       |   |    |    |    |    |    |                |                       |    |    |    |    |    |    |    |    |    |    |    |    |    |    |    |
|                      | String Block Length          |   |   |   |   |   |   |   |                       |   |    |    |    |    |    |                |                       |    |    |    |    |    |    |    |    |    |    |    |    |    |    |    |
|                      | File Path...                 |   |   |   |   |   |   |   |                       |   |    |    |    |    |    |                |                       |    |    |    |    |    |    |    |    |    |    |    |    |    |    |    |
| File SHA Hash        | String Block Type (0)        |   |   |   |   |   |   |   |                       |   |    |    |    |    |    |                |                       |    |    |    |    |    |    |    |    |    |    |    |    |    |    |    |
|                      | String Block Length          |   |   |   |   |   |   |   |                       |   |    |    |    |    |    |                |                       |    |    |    |    |    |    |    |    |    |    |    |    |    |    |    |
|                      | File SHA Hash...             |   |   |   |   |   |   |   |                       |   |    |    |    |    |    |                |                       |    |    |    |    |    |    |    |    |    |    |    |    |    |    |    |
| File Size            |                              |   |   |   |   |   |   |   |                       |   |    |    |    |    |    |                |                       |    |    |    |    |    |    |    |    |    |    |    |    |    |    |    |
| File Type            |                              |   |   |   |   |   |   |   |                       |   |    |    |    |    |    | File Timestamp |                       |    |    |    |    |    |    |    |    |    |    |    |    |    |    |    |
| Parent File Name     | File Timestamp, cont.        |   |   |   |   |   |   |   | String Block Type (0) |   |    |    |    |    |    |                |                       |    |    |    |    |    |    |    |    |    |    |    |    |    |    |    |
|                      | String Block Type (0), cont. |   |   |   |   |   |   |   |                       |   |    |    |    |    |    |                | String Block Length   |    |    |    |    |    |    |    |    |    |    |    |    |    |    |    |
|                      | String Block Length, cont.   |   |   |   |   |   |   |   |                       |   |    |    |    |    |    |                | Parent File Name...   |    |    |    |    |    |    |    |    |    |    |    |    |    |    |    |
| Parent File SHA Hash | String Block Type (0)        |   |   |   |   |   |   |   |                       |   |    |    |    |    |    |                |                       |    |    |    |    |    |    |    |    |    |    |    |    |    |    |    |
|                      | String Block Length          |   |   |   |   |   |   |   |                       |   |    |    |    |    |    |                |                       |    |    |    |    |    |    |    |    |    |    |    |    |    |    |    |
|                      | Parent File SHA Hash...      |   |   |   |   |   |   |   |                       |   |    |    |    |    |    |                |                       |    |    |    |    |    |    |    |    |    |    |    |    |    |    |    |

|                   |                       |   |   |   |   |   |   |   |   |   |    |    |    |    |    |    |    |    |    |    |    |    |    |    |    |    |    |    |    |    |    |    |
|-------------------|-----------------------|---|---|---|---|---|---|---|---|---|----|----|----|----|----|----|----|----|----|----|----|----|----|----|----|----|----|----|----|----|----|----|
| Byte              | 0                     |   |   |   |   |   |   |   | 1 |   |    |    |    |    |    |    | 2  |    |    |    |    |    |    |    | 3  |    |    |    |    |    |    |    |
| Bit               | 0                     | 1 | 2 | 3 | 4 | 5 | 6 | 7 | 8 | 9 | 10 | 11 | 12 | 13 | 14 | 15 | 16 | 17 | 18 | 19 | 20 | 21 | 22 | 23 | 24 | 25 | 26 | 27 | 28 | 29 | 30 | 31 |
| Event Description | String Block Type (0) |   |   |   |   |   |   |   |   |   |    |    |    |    |    |    |    |    |    |    |    |    |    |    |    |    |    |    |    |    |    |    |
|                   | String Block Length   |   |   |   |   |   |   |   |   |   |    |    |    |    |    |    |    |    |    |    |    |    |    |    |    |    |    |    |    |    |    |    |
|                   | Event Description...  |   |   |   |   |   |   |   |   |   |    |    |    |    |    |    |    |    |    |    |    |    |    |    |    |    |    |    |    |    |    |    |

The following table describes the fields in the malware event data block.

**Table B-7 Malware Event Data Block Fields**

| Field                      | Data Type | Description                                                                                                                                                                            |
|----------------------------|-----------|----------------------------------------------------------------------------------------------------------------------------------------------------------------------------------------|
| Malware Event Block Type   | uint32    | Initiates a malware event data block. This value is always 16.                                                                                                                         |
| Malware Event Block Length | uint32    | Total number of bytes in the malware event data block, including eight bytes for the malware event block type and length fields, plus the number of bytes of data that follows.        |
| Agent UUID                 | uint8[16] | The internal unique ID of the FireAMP agent reporting the malware event.                                                                                                               |
| Cloud UUID                 | uint8[16] | The internal unique ID of the malware awareness network from which the malware event originated.                                                                                       |
| Timestamp                  | uint32    | The malware event generation timestamp.                                                                                                                                                |
| Event Type ID              | uint32    | The internal ID of the malware event type.                                                                                                                                             |
| Event Subtype ID           | uint8     | The internal ID of the action that led to malware detection.                                                                                                                           |
| Host IP Address            | uint32    | The host IP address associated with the malware event.                                                                                                                                 |
| Detector ID                | uint8     | The internal ID of the detection technology that detected the malware.                                                                                                                 |
| String Block Type          | uint32    | Initiates a String data block containing the detection name. This value is always 0.                                                                                                   |
| String Block Length        | uint32    | The number of bytes included in the Detection Name String data block, including eight bytes for the block type and header fields plus the number of bytes in the Detection Name field. |
| Detection Name             | string    | The name of the detected or quarantined malware.                                                                                                                                       |
| String Block Type          | uint32    | Initiates a String data block containing the username. This value is always 0.                                                                                                         |
| String Block Length        | uint32    | The number of bytes included in the User String data block, including eight bytes for the block type and header fields plus the number of bytes in the User field.                     |
| User                       | string    | The user of the computer where the Cisco Agent is installed and where the malware event occurred. Note that these users are not tied to user discovery.                                |

Table B-7 Malware Event Data Block Fields (continued)

| Field                | Data Type | Description                                                                                                                                                                                        |
|----------------------|-----------|----------------------------------------------------------------------------------------------------------------------------------------------------------------------------------------------------|
| String Block Type    | uint32    | Initiates a String data block containing the file name. This value is always 0.                                                                                                                    |
| String Block Length  | uint32    | The number of bytes included in the File Name String data block, including eight bytes for the block type and header fields plus the number of bytes in the File Name field.                       |
| File Name            | string    | The name of the detected or quarantined file.                                                                                                                                                      |
| String Block Type    | uint32    | Initiates a String data block containing the file path. This value is always 0.                                                                                                                    |
| String Block Length  | uint32    | The number of bytes included in the File Path String data block, including eight bytes for the block type and header fields plus the number of bytes in the File Path field.                       |
| File Path            | string    | The file path, not including the file name, of the detected or quarantined file.                                                                                                                   |
| String Block Type    | uint32    | Initiates a String data block containing the file SHA hash. This value is always 0.                                                                                                                |
| String Block Length  | uint32    | The number of bytes included in the File SHA Hash String data block, including eight bytes for the block type and header fields plus the number of bytes in the File SHA Hash field.               |
| File SHA Hash        | string    | The SHA-256 hash value of the detected or quarantined file.                                                                                                                                        |
| File Size            | uint32    | The size in bytes of the detected or quarantined file.                                                                                                                                             |
| File Type            | uint8     | The file type of the detected or quarantined file.                                                                                                                                                 |
| File Timestamp       | uint32    | The creation timestamp of the detected or quarantined file.                                                                                                                                        |
| String Block Type    | uint32    | Initiates a String data block containing the parent file name. This value is always 0.                                                                                                             |
| String Block Length  | uint32    | The number of bytes included in the Parent File Name String data block, including eight bytes for the block type and header fields plus the number of bytes in the Parent File Name field.         |
| Parent File Name     | string    | The name of the file accessing the detected or quarantined file when detection occurred.                                                                                                           |
| String Block Type    | uint32    | Initiates a String data block containing the parent file SHA hash. This value is always 0.                                                                                                         |
| String Block Length  | uint32    | The number of bytes included in the Parent File SHA Hash String data block, including eight bytes for the block type and header fields plus the number of bytes in the Parent File SHA Hash field. |
| Parent File SHA Hash | string    | The SHA-256 hash value of the parent file accessing the detected or quarantined file when detection occurred.                                                                                      |
| String Block Type    | uint32    | Initiates a String data block containing the event description. This value is always 0.                                                                                                            |

Table B-7 Malware Event Data Block Fields (continued)

| Field               | Data Type | Description                                                                                                                                                                                  |
|---------------------|-----------|----------------------------------------------------------------------------------------------------------------------------------------------------------------------------------------------|
| String Block Length | uint32    | The number of bytes included in the Event Description String data block, including eight bytes for the block type and header fields plus the number of bytes in the Event Description field. |
| Event Description   | string    | The additional event information associated with the event type.                                                                                                                             |

## Malware Event Data Block 5.1.1.x

The eStreamer service uses the malware event data block to store information on malware events. These events contain information on malware detected or quarantined within a cloud, the detection method, and hosts and users affected by the malware. The malware event data block has a block type of 24 in the series 2 group of blocks. You request the event as part of the malware event record by setting the malware event flag—bit 30 in the request flags field—in the request message with an event version of 2 and an event code of 101.

The following graphic shows the structure of the malware event data block:

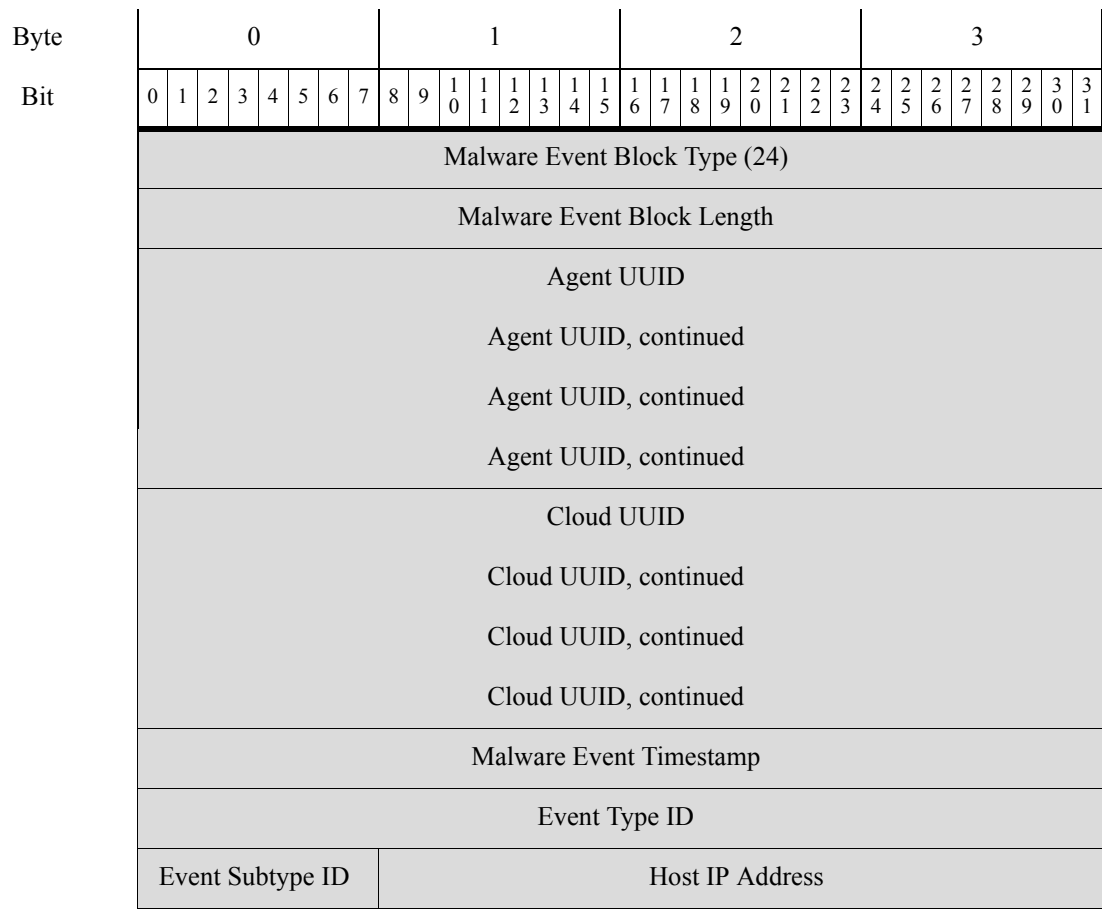

| Byte                 | 0                            |   |   |   |   |   |   |   | 1                     |   |    |    |    |    |    |                | 2                     |    |    |    |    |    |    |    | 3  |    |    |    |    |    |    |    |
|----------------------|------------------------------|---|---|---|---|---|---|---|-----------------------|---|----|----|----|----|----|----------------|-----------------------|----|----|----|----|----|----|----|----|----|----|----|----|----|----|----|
|                      | 0                            | 1 | 2 | 3 | 4 | 5 | 6 | 7 | 8                     | 9 | 10 | 11 | 12 | 13 | 14 | 15             | 16                    | 17 | 18 | 19 | 20 | 21 | 22 | 23 | 24 | 25 | 26 | 27 | 28 | 29 | 30 | 31 |
| Detection Name       | Host IP Address, cont.       |   |   |   |   |   |   |   | Detector ID           |   |    |    |    |    |    |                | String Block Type (0) |    |    |    |    |    |    |    |    |    |    |    |    |    |    |    |
|                      | String Block Type (0), cont. |   |   |   |   |   |   |   |                       |   |    |    |    |    |    |                | String Block Length   |    |    |    |    |    |    |    |    |    |    |    |    |    |    |    |
|                      | String Block Length, cont.   |   |   |   |   |   |   |   |                       |   |    |    |    |    |    |                | Detection Name...     |    |    |    |    |    |    |    |    |    |    |    |    |    |    |    |
| User                 | String Block Type (0)        |   |   |   |   |   |   |   |                       |   |    |    |    |    |    |                |                       |    |    |    |    |    |    |    |    |    |    |    |    |    |    |    |
|                      | String Block Length          |   |   |   |   |   |   |   |                       |   |    |    |    |    |    |                |                       |    |    |    |    |    |    |    |    |    |    |    |    |    |    |    |
|                      | User...                      |   |   |   |   |   |   |   |                       |   |    |    |    |    |    |                |                       |    |    |    |    |    |    |    |    |    |    |    |    |    |    |    |
| File Name            | String Block Type (0)        |   |   |   |   |   |   |   |                       |   |    |    |    |    |    |                |                       |    |    |    |    |    |    |    |    |    |    |    |    |    |    |    |
|                      | String Block Length          |   |   |   |   |   |   |   |                       |   |    |    |    |    |    |                |                       |    |    |    |    |    |    |    |    |    |    |    |    |    |    |    |
|                      | File Name...                 |   |   |   |   |   |   |   |                       |   |    |    |    |    |    |                |                       |    |    |    |    |    |    |    |    |    |    |    |    |    |    |    |
| File Path            | String Block Type (0)        |   |   |   |   |   |   |   |                       |   |    |    |    |    |    |                |                       |    |    |    |    |    |    |    |    |    |    |    |    |    |    |    |
|                      | String Block Length          |   |   |   |   |   |   |   |                       |   |    |    |    |    |    |                |                       |    |    |    |    |    |    |    |    |    |    |    |    |    |    |    |
|                      | File Path...                 |   |   |   |   |   |   |   |                       |   |    |    |    |    |    |                |                       |    |    |    |    |    |    |    |    |    |    |    |    |    |    |    |
| File SHA Hash        | String Block Type (0)        |   |   |   |   |   |   |   |                       |   |    |    |    |    |    |                |                       |    |    |    |    |    |    |    |    |    |    |    |    |    |    |    |
|                      | String Block Length          |   |   |   |   |   |   |   |                       |   |    |    |    |    |    |                |                       |    |    |    |    |    |    |    |    |    |    |    |    |    |    |    |
|                      | File SHA Hash...             |   |   |   |   |   |   |   |                       |   |    |    |    |    |    |                |                       |    |    |    |    |    |    |    |    |    |    |    |    |    |    |    |
| File Size            |                              |   |   |   |   |   |   |   |                       |   |    |    |    |    |    |                |                       |    |    |    |    |    |    |    |    |    |    |    |    |    |    |    |
| File Type            |                              |   |   |   |   |   |   |   |                       |   |    |    |    |    |    | File Timestamp |                       |    |    |    |    |    |    |    |    |    |    |    |    |    |    |    |
| Parent File Name     | File Timestamp, cont.        |   |   |   |   |   |   |   | String Block Type (0) |   |    |    |    |    |    |                |                       |    |    |    |    |    |    |    |    |    |    |    |    |    |    |    |
|                      | String Block Type (0), cont. |   |   |   |   |   |   |   |                       |   |    |    |    |    |    |                | String Block Length   |    |    |    |    |    |    |    |    |    |    |    |    |    |    |    |
|                      | String Block Length, cont.   |   |   |   |   |   |   |   |                       |   |    |    |    |    |    |                | Parent File Name...   |    |    |    |    |    |    |    |    |    |    |    |    |    |    |    |
| Parent File SHA Hash | String Block Type (0)        |   |   |   |   |   |   |   |                       |   |    |    |    |    |    |                |                       |    |    |    |    |    |    |    |    |    |    |    |    |    |    |    |
|                      | String Block Length          |   |   |   |   |   |   |   |                       |   |    |    |    |    |    |                |                       |    |    |    |    |    |    |    |    |    |    |    |    |    |    |    |
|                      | Parent File SHA Hash...      |   |   |   |   |   |   |   |                       |   |    |    |    |    |    |                |                       |    |    |    |    |    |    |    |    |    |    |    |    |    |    |    |

| Byte                  | 0                                |   |   |   |   |   |   |                                       | 1                            |   |    |    |    |    |    |    | 2                   |    |    |    |    |    |    |    | 3                   |    |    |    |    |    |    |    |
|-----------------------|----------------------------------|---|---|---|---|---|---|---------------------------------------|------------------------------|---|----|----|----|----|----|----|---------------------|----|----|----|----|----|----|----|---------------------|----|----|----|----|----|----|----|
| Bit                   | 0                                | 1 | 2 | 3 | 4 | 5 | 6 | 7                                     | 8                            | 9 | 10 | 11 | 12 | 13 | 14 | 15 | 16                  | 17 | 18 | 19 | 20 | 21 | 22 | 23 | 24                  | 25 | 26 | 27 | 28 | 29 | 30 | 31 |
| Event Description     | String Block Type (0)            |   |   |   |   |   |   |                                       |                              |   |    |    |    |    |    |    |                     |    |    |    |    |    |    |    |                     |    |    |    |    |    |    |    |
|                       | String Block Length              |   |   |   |   |   |   |                                       |                              |   |    |    |    |    |    |    |                     |    |    |    |    |    |    |    |                     |    |    |    |    |    |    |    |
|                       | Event Description...             |   |   |   |   |   |   |                                       |                              |   |    |    |    |    |    |    |                     |    |    |    |    |    |    |    |                     |    |    |    |    |    |    |    |
|                       | Device ID                        |   |   |   |   |   |   |                                       |                              |   |    |    |    |    |    |    |                     |    |    |    |    |    |    |    |                     |    |    |    |    |    |    |    |
|                       | Connection Instance              |   |   |   |   |   |   |                                       |                              |   |    |    |    |    |    |    | Connection Counter  |    |    |    |    |    |    |    |                     |    |    |    |    |    |    |    |
|                       | Connection Event Timestamp       |   |   |   |   |   |   |                                       |                              |   |    |    |    |    |    |    |                     |    |    |    |    |    |    |    |                     |    |    |    |    |    |    |    |
|                       | Direction                        |   |   |   |   |   |   |                                       | Source IP Address            |   |    |    |    |    |    |    |                     |    |    |    |    |    |    |    |                     |    |    |    |    |    |    |    |
|                       | Source IP, cont.                 |   |   |   |   |   |   |                                       | Source IP Address, continued |   |    |    |    |    |    |    |                     |    |    |    |    |    |    |    |                     |    |    |    |    |    |    |    |
|                       |                                  |   |   |   |   |   |   |                                       | Source IP Address, continued |   |    |    |    |    |    |    |                     |    |    |    |    |    |    |    |                     |    |    |    |    |    |    |    |
|                       |                                  |   |   |   |   |   |   |                                       | Source IP Address, continued |   |    |    |    |    |    |    |                     |    |    |    |    |    |    |    |                     |    |    |    |    |    |    |    |
| Destination IP, cont. |                                  |   |   |   |   |   |   | Destination IP Address                |                              |   |    |    |    |    |    |    |                     |    |    |    |    |    |    |    |                     |    |    |    |    |    |    |    |
|                       |                                  |   |   |   |   |   |   | Destination IP Address, continued     |                              |   |    |    |    |    |    |    |                     |    |    |    |    |    |    |    |                     |    |    |    |    |    |    |    |
|                       |                                  |   |   |   |   |   |   | Destination IP Address, continued     |                              |   |    |    |    |    |    |    |                     |    |    |    |    |    |    |    |                     |    |    |    |    |    |    |    |
| App. ID, cont.        |                                  |   |   |   |   |   |   | Application ID                        |                              |   |    |    |    |    |    |    |                     |    |    |    |    |    |    |    |                     |    |    |    |    |    |    |    |
|                       |                                  |   |   |   |   |   |   | User ID                               |                              |   |    |    |    |    |    |    |                     |    |    |    |    |    |    |    |                     |    |    |    |    |    |    |    |
|                       |                                  |   |   |   |   |   |   | Access Control Policy UUID            |                              |   |    |    |    |    |    |    |                     |    |    |    |    |    |    |    |                     |    |    |    |    |    |    |    |
| User ID, cont.        |                                  |   |   |   |   |   |   | Access Control Policy UUID, continued |                              |   |    |    |    |    |    |    |                     |    |    |    |    |    |    |    |                     |    |    |    |    |    |    |    |
|                       |                                  |   |   |   |   |   |   | Access Control Policy UUID, continued |                              |   |    |    |    |    |    |    |                     |    |    |    |    |    |    |    |                     |    |    |    |    |    |    |    |
|                       |                                  |   |   |   |   |   |   | Access Control Policy UUID, continued |                              |   |    |    |    |    |    |    |                     |    |    |    |    |    |    |    |                     |    |    |    |    |    |    |    |
| URI                   | AC Pol UUID, cont.               |   |   |   |   |   |   |                                       | Disposition                  |   |    |    |    |    |    |    | Retro. Disposition  |    |    |    |    |    |    |    | Str. Block Type (0) |    |    |    |    |    |    |    |
|                       | String Block Type (0), continued |   |   |   |   |   |   |                                       |                              |   |    |    |    |    |    |    | String Block Length |    |    |    |    |    |    |    |                     |    |    |    |    |    |    |    |
|                       | String Block Length, continued   |   |   |   |   |   |   |                                       |                              |   |    |    |    |    |    |    | URI...              |    |    |    |    |    |    |    |                     |    |    |    |    |    |    |    |
|                       | Source Port                      |   |   |   |   |   |   |                                       |                              |   |    |    |    |    |    |    | Destination Port    |    |    |    |    |    |    |    |                     |    |    |    |    |    |    |    |

The following table describes the fields in the malware event data block.

**Table B-8** Malware Event Data Block for 5.1.1.x Fields

| Field                      | Data Type | Description                                                                                                                                                                            |
|----------------------------|-----------|----------------------------------------------------------------------------------------------------------------------------------------------------------------------------------------|
| Malware Event Block Type   | uint32    | Initiates a malware event data block. This value is always 24.                                                                                                                         |
| Malware Event Block Length | uint32    | Total number of bytes in the malware event data block, including eight bytes for the malware event block type and length fields, plus the number of bytes of data that follows.        |
| Agent UUID                 | uint8[16] | The internal unique ID of the FireAMP agent reporting the malware event.                                                                                                               |
| Cloud UUID                 | uint8[16] | The internal unique ID of the malware awareness network from which the malware event originated.                                                                                       |
| Malware Event Timestamp    | uint32    | The malware event generation timestamp.                                                                                                                                                |
| Event Type ID              | uint32    | The internal ID of the malware event type.                                                                                                                                             |
| Event Subtype ID           | uint8     | The internal ID of the action that led to malware detection.                                                                                                                           |
| Host IP Address            | uint32    | The host IP address associated with the malware event.                                                                                                                                 |
| Detector ID                | uint8     | The internal ID of the detection technology that detected the malware.                                                                                                                 |
| String Block Type          | uint32    | Initiates a String data block containing the detection name. This value is always 0.                                                                                                   |
| String Block Length        | uint32    | The number of bytes included in the Detection Name String data block, including eight bytes for the block type and header fields plus the number of bytes in the Detection Name field. |
| Detection Name             | string    | The name of the detected or quarantined malware.                                                                                                                                       |
| String Block Type          | uint32    | Initiates a String data block containing the username. This value is always 0.                                                                                                         |
| String Block Length        | uint32    | The number of bytes included in the User String data block, including eight bytes for the block type and header fields plus the number of bytes in the User field.                     |
| User                       | string    | The user of the computer where the Cisco Agent is installed and where the malware event occurred. Note that these users are not tied to user discovery.                                |
| String Block Type          | uint32    | Initiates a String data block containing the file name. This value is always 0.                                                                                                        |
| String Block Length        | uint32    | The number of bytes included in the File Name String data block, including eight bytes for the block type and header fields plus the number of bytes in the File Name field.           |
| File Name                  | string    | The name of the detected or quarantined file.                                                                                                                                          |
| String Block Type          | uint32    | Initiates a String data block containing the file path. This value is always 0.                                                                                                        |

Table B-8 Malware Event Data Block for 5.1.1.x Fields (continued)

| Field                | Data Type | Description                                                                                                                                                                                        |
|----------------------|-----------|----------------------------------------------------------------------------------------------------------------------------------------------------------------------------------------------------|
| String Block Length  | uint32    | The number of bytes included in the File Path String data block, including eight bytes for the block type and header fields plus the number of bytes in the File Path field.                       |
| File Path            | string    | The file path, not including the file name, of the detected or quarantined file.                                                                                                                   |
| String Block Type    | uint32    | Initiates a String data block containing the file SHA hash. This value is always 0.                                                                                                                |
| String Block Length  | uint32    | The number of bytes included in the File SHA Hash String data block, including eight bytes for the block type and header fields plus the number of bytes in the File SHA Hash field.               |
| File SHA Hash        | string    | The rendered string of the SHA-256 hash value of the detected or quarantined file.                                                                                                                 |
| File Size            | uint32    | The size in bytes of the detected or quarantined file.                                                                                                                                             |
| File Type            | uint8     | The file type of the detected or quarantined file.                                                                                                                                                 |
| File Timestamp       | uint32    | UNIX timestamp (seconds since 01/01/1970) of the creation of the detected or quarantined file.                                                                                                     |
| String Block Type    | uint32    | Initiates a String data block containing the parent file name. This value is always 0.                                                                                                             |
| String Block Length  | uint32    | The number of bytes included in the Parent File Name String data block, including eight bytes for the block type and header fields plus the number of bytes in the Parent File Name field.         |
| Parent File Name     | string    | The name of the file accessing the detected or quarantined file when detection occurred.                                                                                                           |
| String Block Type    | uint32    | Initiates a String data block containing the parent file SHA hash. This value is always 0.                                                                                                         |
| String Block Length  | uint32    | The number of bytes included in the Parent File SHA Hash String data block, including eight bytes for the block type and header fields plus the number of bytes in the Parent File SHA Hash field. |
| Parent File SHA Hash | string    | The SHA-256 hash value of the parent file accessing the detected or quarantined file when detection occurred.                                                                                      |
| String Block Type    | uint32    | Initiates a String data block containing the event description. This value is always 0.                                                                                                            |
| String Block Length  | uint32    | The number of bytes included in the Event Description String data block, including eight bytes for the block type and header fields plus the number of bytes in the Event Description field.       |
| Event Description    | string    | The additional event information associated with the event type.                                                                                                                                   |
| Device ID            | uint32    | ID for the device that generated the event.                                                                                                                                                        |



Table B-8 Malware Event Data Block for 5.1.1.x Fields (continued)

| Field                      | Data Type | Description                                                                                                                                                                                                                                                                                                                                                                                                                                                                                                |
|----------------------------|-----------|------------------------------------------------------------------------------------------------------------------------------------------------------------------------------------------------------------------------------------------------------------------------------------------------------------------------------------------------------------------------------------------------------------------------------------------------------------------------------------------------------------|
| Connection Instance        | uint16    | Snort instance on the device that generated the event. Used to link the event with a connection or IDS event.                                                                                                                                                                                                                                                                                                                                                                                              |
| Connection Counter         | uint16    | Value used to distinguish between connection events that happen during the same second.                                                                                                                                                                                                                                                                                                                                                                                                                    |
| Connection Event Timestamp | uint32    | Timestamp of the connection event.                                                                                                                                                                                                                                                                                                                                                                                                                                                                         |
| Direction                  | uint8     | Indicates whether the file was uploaded or downloaded. Can have the following values: <ul style="list-style-type: none"> <li>• 1 - Download</li> <li>• 2 - Upload</li> </ul> Currently the value depends on the protocol (for example, if the connection is HTTP it is a download).                                                                                                                                                                                                                        |
| Source IP Address          | uint8[16] | IPv4 or IPv6 address for the source of the connection.                                                                                                                                                                                                                                                                                                                                                                                                                                                     |
| Destination IP Address     | uint8[16] | IPv4 or IPv6 address for the destination of the connection.                                                                                                                                                                                                                                                                                                                                                                                                                                                |
| Application ID             | uint32    | ID number that maps to the application using the file transfer.                                                                                                                                                                                                                                                                                                                                                                                                                                            |
| User ID                    | uint32    | Identification number for the user logged into the destination host, as identified by the system.                                                                                                                                                                                                                                                                                                                                                                                                          |
| Access Control Policy UUID | uint8[16] | Identification number that acts as a unique identifier for the access control policy that triggered the event.                                                                                                                                                                                                                                                                                                                                                                                             |
| Disposition                | uint8     | The malware status of the file. Possible values include: <ul style="list-style-type: none"> <li>• 1 - CLEAN - The file is clean and does not contain malware.</li> <li>• 2 - UNKNOWN - It is unknown whether the file contains malware.</li> <li>• 3 - MALWARE - The file contains malware.</li> <li>• 4 - CACHE_MISS - The software was unable to send a request to the Cisco cloud for a disposition.</li> <li>• 5 - NO_CLOUD_RESP - The Cisco cloud services did not respond to the request.</li> </ul> |
| Retrospective Disposition  | uint8     | Disposition of the file if the disposition is updated. If the disposition is not updated, this field contains the same value as the Disposition field. The possible values are the same as the Disposition field.                                                                                                                                                                                                                                                                                          |
| String Block Type          | uint32    | Initiates a String data block containing the URI. This value is always 0.                                                                                                                                                                                                                                                                                                                                                                                                                                  |
| String Block Length        | uint32    | The number of bytes included in the URI data block, including eight bytes for the block type and header fields plus the number of bytes in the URI field.                                                                                                                                                                                                                                                                                                                                                  |
| URI                        | string    | URI of the connection.                                                                                                                                                                                                                                                                                                                                                                                                                                                                                     |

Table B-8 Malware Event Data Block for 5.1.1.x Fields (continued)

| Field            | Data Type | Description                                        |
|------------------|-----------|----------------------------------------------------|
| Source Port      | uint16    | Port number for the source of the connection.      |
| Destination Port | uint16    | Port number for the destination of the connection. |

## Malware Event Data Block 5.2.x

The eStreamer service uses the malware event data block to store information on malware events. These events contain information on malware detected or quarantined within a cloud, the detection method, and hosts and users affected by the malware. The malware event data block has a block type of 33 in the series 2 group of blocks. You request the event as part of the malware event record by setting the malware event flag—bit 30 in the request flags field—in the request message with an event version of 3 and an event code of 101.

The following graphic shows the structure of the malware event data block:

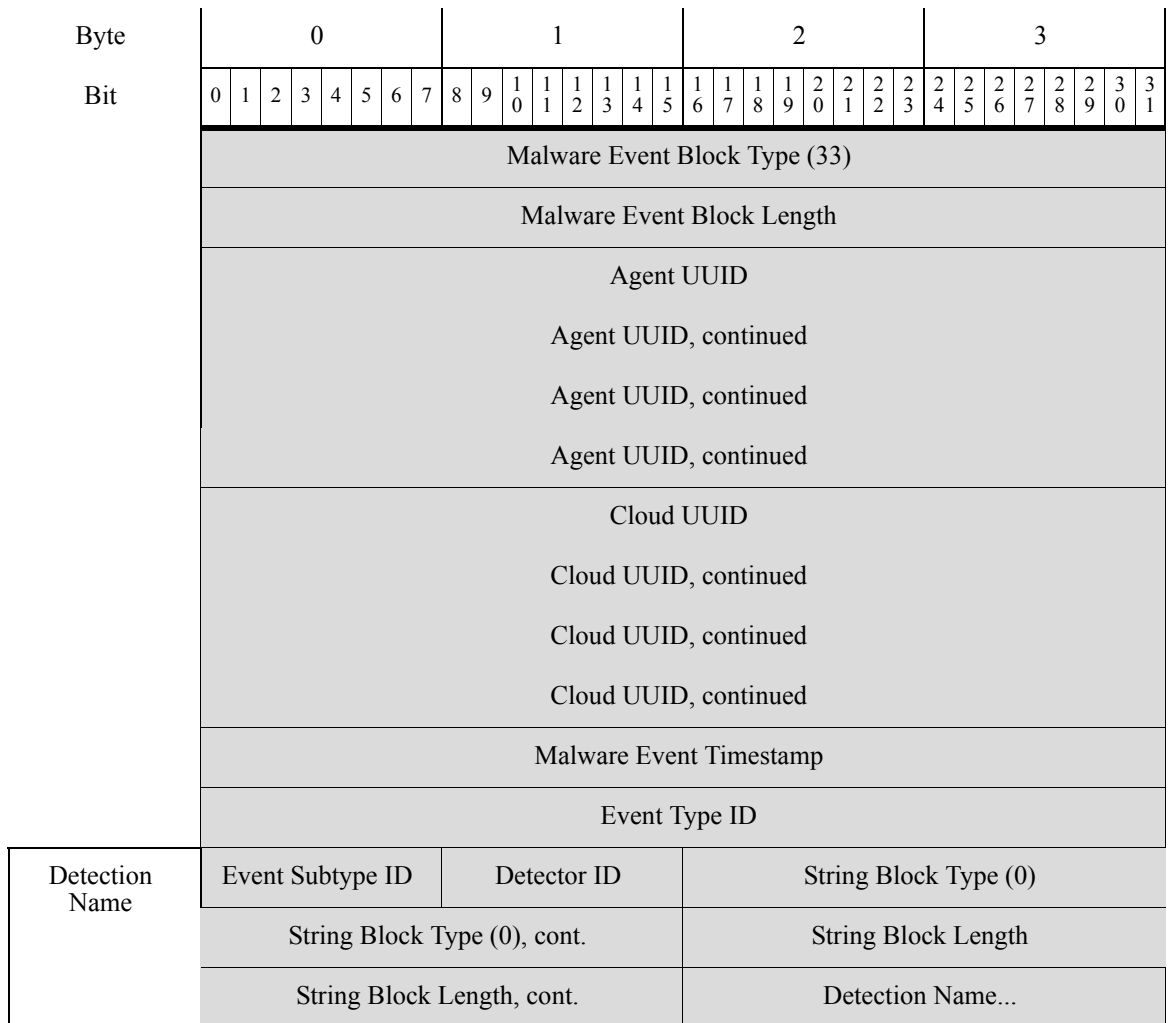

| Byte                 | 0                       |   |   |   |   |   |   |   | 1 |   |    |    |    |    |    |                    | 2  |    |    |    |    |    |    |    | 3  |    |    |    |    |    |    |    |
|----------------------|-------------------------|---|---|---|---|---|---|---|---|---|----|----|----|----|----|--------------------|----|----|----|----|----|----|----|----|----|----|----|----|----|----|----|----|
|                      | 0                       | 1 | 2 | 3 | 4 | 5 | 6 | 7 | 8 | 9 | 10 | 11 | 12 | 13 | 14 | 15                 | 16 | 17 | 18 | 19 | 20 | 21 | 22 | 23 | 24 | 25 | 26 | 27 | 28 | 29 | 30 | 31 |
| User                 | String Block Type (0)   |   |   |   |   |   |   |   |   |   |    |    |    |    |    |                    |    |    |    |    |    |    |    |    |    |    |    |    |    |    |    |    |
|                      | String Block Length     |   |   |   |   |   |   |   |   |   |    |    |    |    |    |                    |    |    |    |    |    |    |    |    |    |    |    |    |    |    |    |    |
|                      | User...                 |   |   |   |   |   |   |   |   |   |    |    |    |    |    |                    |    |    |    |    |    |    |    |    |    |    |    |    |    |    |    |    |
| File Name            | String Block Type (0)   |   |   |   |   |   |   |   |   |   |    |    |    |    |    |                    |    |    |    |    |    |    |    |    |    |    |    |    |    |    |    |    |
|                      | String Block Length     |   |   |   |   |   |   |   |   |   |    |    |    |    |    |                    |    |    |    |    |    |    |    |    |    |    |    |    |    |    |    |    |
|                      | File Name...            |   |   |   |   |   |   |   |   |   |    |    |    |    |    |                    |    |    |    |    |    |    |    |    |    |    |    |    |    |    |    |    |
| File Path            | String Block Type (0)   |   |   |   |   |   |   |   |   |   |    |    |    |    |    |                    |    |    |    |    |    |    |    |    |    |    |    |    |    |    |    |    |
|                      | String Block Length     |   |   |   |   |   |   |   |   |   |    |    |    |    |    |                    |    |    |    |    |    |    |    |    |    |    |    |    |    |    |    |    |
|                      | File Path...            |   |   |   |   |   |   |   |   |   |    |    |    |    |    |                    |    |    |    |    |    |    |    |    |    |    |    |    |    |    |    |    |
| File SHA Hash        | String Block Type (0)   |   |   |   |   |   |   |   |   |   |    |    |    |    |    |                    |    |    |    |    |    |    |    |    |    |    |    |    |    |    |    |    |
|                      | String Block Length     |   |   |   |   |   |   |   |   |   |    |    |    |    |    |                    |    |    |    |    |    |    |    |    |    |    |    |    |    |    |    |    |
|                      | File SHA Hash...        |   |   |   |   |   |   |   |   |   |    |    |    |    |    |                    |    |    |    |    |    |    |    |    |    |    |    |    |    |    |    |    |
| File Size            |                         |   |   |   |   |   |   |   |   |   |    |    |    |    |    |                    |    |    |    |    |    |    |    |    |    |    |    |    |    |    |    |    |
| File Type            |                         |   |   |   |   |   |   |   |   |   |    |    |    |    |    |                    |    |    |    |    |    |    |    |    |    |    |    |    |    |    |    |    |
| File Timestamp       |                         |   |   |   |   |   |   |   |   |   |    |    |    |    |    |                    |    |    |    |    |    |    |    |    |    |    |    |    |    |    |    |    |
| Parent File Name     | String Block Type (0)   |   |   |   |   |   |   |   |   |   |    |    |    |    |    |                    |    |    |    |    |    |    |    |    |    |    |    |    |    |    |    |    |
|                      | String Block Length     |   |   |   |   |   |   |   |   |   |    |    |    |    |    |                    |    |    |    |    |    |    |    |    |    |    |    |    |    |    |    |    |
|                      | Parent File Name...     |   |   |   |   |   |   |   |   |   |    |    |    |    |    |                    |    |    |    |    |    |    |    |    |    |    |    |    |    |    |    |    |
| Parent File SHA Hash | String Block Type (0)   |   |   |   |   |   |   |   |   |   |    |    |    |    |    |                    |    |    |    |    |    |    |    |    |    |    |    |    |    |    |    |    |
|                      | String Block Length     |   |   |   |   |   |   |   |   |   |    |    |    |    |    |                    |    |    |    |    |    |    |    |    |    |    |    |    |    |    |    |    |
|                      | Parent File SHA Hash... |   |   |   |   |   |   |   |   |   |    |    |    |    |    |                    |    |    |    |    |    |    |    |    |    |    |    |    |    |    |    |    |
| Event Description    | String Block Type (0)   |   |   |   |   |   |   |   |   |   |    |    |    |    |    |                    |    |    |    |    |    |    |    |    |    |    |    |    |    |    |    |    |
|                      | String Block Length     |   |   |   |   |   |   |   |   |   |    |    |    |    |    |                    |    |    |    |    |    |    |    |    |    |    |    |    |    |    |    |    |
|                      | Event Description...    |   |   |   |   |   |   |   |   |   |    |    |    |    |    |                    |    |    |    |    |    |    |    |    |    |    |    |    |    |    |    |    |
| Device ID            |                         |   |   |   |   |   |   |   |   |   |    |    |    |    |    |                    |    |    |    |    |    |    |    |    |    |    |    |    |    |    |    |    |
| Connection Instance  |                         |   |   |   |   |   |   |   |   |   |    |    |    |    |    | Connection Counter |    |    |    |    |    |    |    |    |    |    |    |    |    |    |    |    |

| Byte                  | 0                                |   |   |   |   |   |   |   | 1                                     |   |    |    |    |    |    |                     | 2                   |    |    |    |    |    |    |    | 3                   |    |    |    |    |    |    |    |
|-----------------------|----------------------------------|---|---|---|---|---|---|---|---------------------------------------|---|----|----|----|----|----|---------------------|---------------------|----|----|----|----|----|----|----|---------------------|----|----|----|----|----|----|----|
| Bit                   | 0                                | 1 | 2 | 3 | 4 | 5 | 6 | 7 | 8                                     | 9 | 10 | 11 | 12 | 13 | 14 | 15                  | 16                  | 17 | 18 | 19 | 20 | 21 | 22 | 23 | 24                  | 25 | 26 | 27 | 28 | 29 | 30 | 31 |
|                       | Connection Event Timestamp       |   |   |   |   |   |   |   |                                       |   |    |    |    |    |    |                     |                     |    |    |    |    |    |    |    |                     |    |    |    |    |    |    |    |
|                       | Direction                        |   |   |   |   |   |   |   | Source IP Address                     |   |    |    |    |    |    |                     |                     |    |    |    |    |    |    |    |                     |    |    |    |    |    |    |    |
|                       |                                  |   |   |   |   |   |   |   | Source IP Address, continued          |   |    |    |    |    |    |                     |                     |    |    |    |    |    |    |    |                     |    |    |    |    |    |    |    |
|                       |                                  |   |   |   |   |   |   |   | Source IP Address, continued          |   |    |    |    |    |    |                     |                     |    |    |    |    |    |    |    |                     |    |    |    |    |    |    |    |
|                       |                                  |   |   |   |   |   |   |   | Source IP Address, continued          |   |    |    |    |    |    |                     |                     |    |    |    |    |    |    |    |                     |    |    |    |    |    |    |    |
|                       | Source IP, cont.                 |   |   |   |   |   |   |   | Destination IP Address                |   |    |    |    |    |    |                     |                     |    |    |    |    |    |    |    |                     |    |    |    |    |    |    |    |
|                       |                                  |   |   |   |   |   |   |   | Destination IP Address, continued     |   |    |    |    |    |    |                     |                     |    |    |    |    |    |    |    |                     |    |    |    |    |    |    |    |
|                       |                                  |   |   |   |   |   |   |   | Destination IP Address, continued     |   |    |    |    |    |    |                     |                     |    |    |    |    |    |    |    |                     |    |    |    |    |    |    |    |
|                       |                                  |   |   |   |   |   |   |   | Destination IP Address, continued     |   |    |    |    |    |    |                     |                     |    |    |    |    |    |    |    |                     |    |    |    |    |    |    |    |
|                       | Destination IP, cont             |   |   |   |   |   |   |   | Application ID                        |   |    |    |    |    |    |                     |                     |    |    |    |    |    |    |    |                     |    |    |    |    |    |    |    |
|                       | App. ID, cont.                   |   |   |   |   |   |   |   | User ID                               |   |    |    |    |    |    |                     |                     |    |    |    |    |    |    |    |                     |    |    |    |    |    |    |    |
|                       | User ID, cont.                   |   |   |   |   |   |   |   | Access Control Policy UUID            |   |    |    |    |    |    |                     |                     |    |    |    |    |    |    |    |                     |    |    |    |    |    |    |    |
|                       |                                  |   |   |   |   |   |   |   | Access Control Policy UUID, continued |   |    |    |    |    |    |                     |                     |    |    |    |    |    |    |    |                     |    |    |    |    |    |    |    |
|                       |                                  |   |   |   |   |   |   |   | Access Control Policy UUID, continued |   |    |    |    |    |    |                     |                     |    |    |    |    |    |    |    |                     |    |    |    |    |    |    |    |
|                       |                                  |   |   |   |   |   |   |   | Access Control Policy UUID, continued |   |    |    |    |    |    |                     |                     |    |    |    |    |    |    |    |                     |    |    |    |    |    |    |    |
| URI                   | AC Pol UUID, cont.               |   |   |   |   |   |   |   | Disposition                           |   |    |    |    |    |    |                     | Retro. Disposition  |    |    |    |    |    |    |    | Str. Block Type (0) |    |    |    |    |    |    |    |
|                       | String Block Type (0), continued |   |   |   |   |   |   |   |                                       |   |    |    |    |    |    |                     | String Block Length |    |    |    |    |    |    |    |                     |    |    |    |    |    |    |    |
|                       | String Block Length, continued   |   |   |   |   |   |   |   |                                       |   |    |    |    |    |    |                     | URI...              |    |    |    |    |    |    |    |                     |    |    |    |    |    |    |    |
|                       | Source Port                      |   |   |   |   |   |   |   |                                       |   |    |    |    |    |    |                     | Destination Port    |    |    |    |    |    |    |    |                     |    |    |    |    |    |    |    |
| Source Country        |                                  |   |   |   |   |   |   |   |                                       |   |    |    |    |    |    | Destination Country |                     |    |    |    |    |    |    |    |                     |    |    |    |    |    |    |    |
| Web Application ID    |                                  |   |   |   |   |   |   |   |                                       |   |    |    |    |    |    |                     |                     |    |    |    |    |    |    |    |                     |    |    |    |    |    |    |    |
| Client Application ID |                                  |   |   |   |   |   |   |   |                                       |   |    |    |    |    |    |                     |                     |    |    |    |    |    |    |    |                     |    |    |    |    |    |    |    |
| Action                |                                  |   |   |   |   |   |   |   |                                       |   |    |    |    |    |    | Protocol            |                     |    |    |    |    |    |    |    |                     |    |    |    |    |    |    |    |

The following table describes the fields in the malware event data block.

**Table B-9 Malware Event Data Block for 5.2.x Fields**

| Field                      | Data Type | Description                                                                                                                                                                            |
|----------------------------|-----------|----------------------------------------------------------------------------------------------------------------------------------------------------------------------------------------|
| Malware Event Block Type   | uint32    | Initiates a malware event data block. This value is always 33.                                                                                                                         |
| Malware Event Block Length | uint32    | Total number of bytes in the malware event data block, including eight bytes for the malware event block type and length fields, plus the number of bytes of data that follows.        |
| Agent UUID                 | uint8[16] | The internal unique ID of the FireAMP agent reporting the malware event.                                                                                                               |
| Cloud UUID                 | uint8[16] | The internal unique ID of the malware awareness network from which the malware event originated.                                                                                       |
| Malware Event Timestamp    | uint32    | The malware event generation timestamp.                                                                                                                                                |
| Event Type ID              | uint32    | The internal ID of the malware event type.                                                                                                                                             |
| Event Subtype ID           | uint8     | The internal ID of the action that led to malware detection.                                                                                                                           |
| Detector ID                | uint8     | The internal ID of the detection technology that detected the malware.                                                                                                                 |
| String Block Type          | uint32    | Initiates a String data block containing the detection name. This value is always 0.                                                                                                   |
| String Block Length        | uint32    | The number of bytes included in the Detection Name String data block, including eight bytes for the block type and header fields plus the number of bytes in the Detection Name field. |
| Detection Name             | string    | The name of the detected or quarantined malware.                                                                                                                                       |
| String Block Type          | uint32    | Initiates a String data block containing the username. This value is always 0.                                                                                                         |
| String Block Length        | uint32    | The number of bytes included in the User String data block, including eight bytes for the block type and header fields plus the number of bytes in the User field.                     |
| User                       | string    | The user of the computer where the Cisco Agent is installed and where the malware event occurred. Note that these users are not tied to user discovery.                                |
| String Block Type          | uint32    | Initiates a String data block containing the file name. This value is always 0.                                                                                                        |
| String Block Length        | uint32    | The number of bytes included in the File Name String data block, including eight bytes for the block type and header fields plus the number of bytes in the File Name field.           |
| File Name                  | string    | The name of the detected or quarantined file.                                                                                                                                          |
| String Block Type          | uint32    | Initiates a String data block containing the file path. This value is always 0.                                                                                                        |
| String Block Length        | uint32    | The number of bytes included in the File Path String data block, including eight bytes for the block type and header fields plus the number of bytes in the File Path field.           |

Table B-9 Malware Event Data Block for 5.2.x Fields (continued)

| Field                | Data Type | Description                                                                                                                                                                                        |
|----------------------|-----------|----------------------------------------------------------------------------------------------------------------------------------------------------------------------------------------------------|
| File Path            | string    | The file path, not including the file name, of the detected or quarantined file.                                                                                                                   |
| String Block Type    | uint32    | Initiates a String data block containing the file SHA hash. This value is always 0.                                                                                                                |
| String Block Length  | uint32    | The number of bytes included in the File SHA Hash String data block, including eight bytes for the block type and header fields plus the number of bytes in the File SHA Hash field.               |
| File SHA Hash        | string    | The rendered string of the SHA-256 hash value of the detected or quarantined file.                                                                                                                 |
| File Size            | uint32    | The size in bytes of the detected or quarantined file.                                                                                                                                             |
| File Type            | uint32    | The file type of the detected or quarantined file.                                                                                                                                                 |
| File Timestamp       | uint32    | UNIX timestamp (seconds since 01/01/1970) of the creation of the detected or quarantined file.                                                                                                     |
| String Block Type    | uint32    | Initiates a String data block containing the parent file name. This value is always 0.                                                                                                             |
| String Block Length  | uint32    | The number of bytes included in the Parent File Name String data block, including eight bytes for the block type and header fields plus the number of bytes in the Parent File Name field.         |
| Parent File Name     | string    | The name of the file accessing the detected or quarantined file when detection occurred.                                                                                                           |
| String Block Type    | uint32    | Initiates a String data block containing the parent file SHA hash. This value is always 0.                                                                                                         |
| String Block Length  | uint32    | The number of bytes included in the Parent File SHA Hash String data block, including eight bytes for the block type and header fields plus the number of bytes in the Parent File SHA Hash field. |
| Parent File SHA Hash | string    | The SHA-256 hash value of the parent file accessing the detected or quarantined file when detection occurred.                                                                                      |
| String Block Type    | uint32    | Initiates a String data block containing the event description. This value is always 0.                                                                                                            |
| String Block Length  | uint32    | The number of bytes included in the Event Description String data block, including eight bytes for the block type and header fields plus the number of bytes in the Event Description field.       |
| Event Description    | string    | The additional event information associated with the event type.                                                                                                                                   |
| Device ID            | uint32    | ID for the device that generated the event.                                                                                                                                                        |
| Connection Instance  | uint16    | Snort instance on the device that generated the event. Used to link the event with a connection or IDS event.                                                                                      |
| Connection Counter   | uint16    | Value used to distinguish between connection events that happen during the same second.                                                                                                            |

Table B-9 Malware Event Data Block for 5.2.x Fields (continued)

| Field                      | Data Type | Description                                                                                                                                                                                                                                                                                                                                                                                                                                                                    |
|----------------------------|-----------|--------------------------------------------------------------------------------------------------------------------------------------------------------------------------------------------------------------------------------------------------------------------------------------------------------------------------------------------------------------------------------------------------------------------------------------------------------------------------------|
| Connection Event Timestamp | uint32    | Timestamp of the connection event.                                                                                                                                                                                                                                                                                                                                                                                                                                             |
| Direction                  | uint8     | Indicates whether the file was uploaded or downloaded. Can have the following values: <ul style="list-style-type: none"> <li>• 1 - Download</li> <li>• 2 - Upload</li> </ul> Currently the value depends on the protocol (for example, if the connection is HTTP it is a download).                                                                                                                                                                                            |
| Source IP Address          | uint8[16] | IPv4 or IPv6 address for the source of the connection.                                                                                                                                                                                                                                                                                                                                                                                                                         |
| Destination IP Address     | uint8[16] | IPv4 or IPv6 address for the destination of the connection.                                                                                                                                                                                                                                                                                                                                                                                                                    |
| Application ID             | uint32    | ID number that maps to the application using the file transfer.                                                                                                                                                                                                                                                                                                                                                                                                                |
| User ID                    | uint32    | Identification number for the user logged into the destination host, as identified by the system.                                                                                                                                                                                                                                                                                                                                                                              |
| Access Control Policy UUID | uint8[16] | Identification number that acts as a unique identifier for the access control policy that triggered the event.                                                                                                                                                                                                                                                                                                                                                                 |
| Disposition                | uint8     | The malware status of the file. Possible values include: <ul style="list-style-type: none"> <li>• 1 - CLEAN - The file is clean and does not contain malware.</li> <li>• 2 - NEUTRAL - It is unknown whether the file contains malware.</li> <li>• 3 - MALWARE - The file contains malware.</li> <li>• 4 - CACHE_MISS - The software was unable to send a request to the Cisco cloud for a disposition, or the Cisco cloud services did not respond to the request.</li> </ul> |
| Retrospective Disposition  | uint8     | Disposition of the file if the disposition is updated. If the disposition is not updated, this field contains the same value as the Disposition field. The possible values are the same as the Disposition field.                                                                                                                                                                                                                                                              |
| String Block Type          | uint32    | Initiates a String data block containing the URI. This value is always 0.                                                                                                                                                                                                                                                                                                                                                                                                      |
| String Block Length        | uint32    | The number of bytes included in the URI data block, including eight bytes for the block type and header fields plus the number of bytes in the URI field.                                                                                                                                                                                                                                                                                                                      |
| URI                        | string    | URI of the connection.                                                                                                                                                                                                                                                                                                                                                                                                                                                         |
| Source Port                | uint16    | Port number for the source of the connection.                                                                                                                                                                                                                                                                                                                                                                                                                                  |
| Destination Port           | uint16    | Port number for the destination of the connection.                                                                                                                                                                                                                                                                                                                                                                                                                             |
| Source Country             | uint16    | Code for the country of the source host.                                                                                                                                                                                                                                                                                                                                                                                                                                       |
| Destination Country        | uint16    | Code for the country of the destination host.                                                                                                                                                                                                                                                                                                                                                                                                                                  |
| Web Application ID         | uint32    | The internal identification number of the detected web application, if applicable.                                                                                                                                                                                                                                                                                                                                                                                             |

Table B-9 Malware Event Data Block for 5.2.x Fields (continued)

| Field                 | Data Type | Description                                                                                                                                                                                                                                                               |
|-----------------------|-----------|---------------------------------------------------------------------------------------------------------------------------------------------------------------------------------------------------------------------------------------------------------------------------|
| Client Application ID | uint32    | The internal identification number of the detected client application, if applicable.                                                                                                                                                                                     |
| Action                | uint8     | The action taken on the file based on the file type. Can have the following values: <ul style="list-style-type: none"> <li>• 1 - Detect</li> <li>• 2 - Block</li> <li>• 3 - Malware Cloud Lookup</li> <li>• 4 - Malware Block</li> <li>• 5 - Malware Whitelist</li> </ul> |
| Protocol              | uint8     | IANA protocol number specified by the user. For example: <ul style="list-style-type: none"> <li>• 1 - ICMP</li> <li>• 4 - IP</li> <li>• 6 - TCP</li> <li>• 17 - UDP</li> </ul> This is currently only TCP.                                                                |

## Malware Event Data Block 5.3

The eStreamer service uses the malware event data block to store information on malware events. These events contain information on malware detected or quarantined within a cloud, the detection method, and hosts and users affected by the malware. The malware event data block has a block type of 35 in the series 2 group of blocks. You request the event as part of the malware event record by setting the malware event flag—bit 30 in the request flags field—in the request message with an event version of 4 and an event code of 101.

The following graphic shows the structure of the malware event data block:

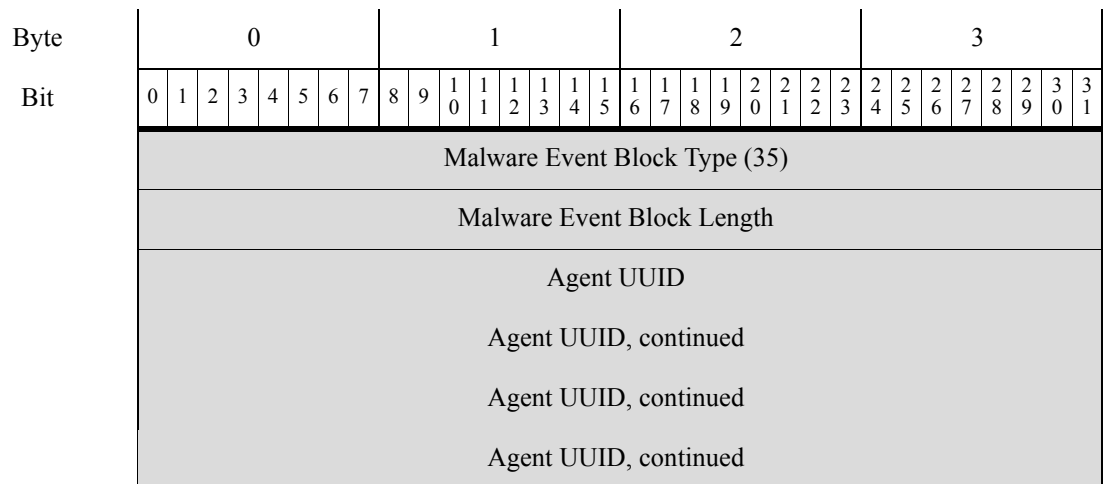



| Byte           | 0                            |   |   |   |   |   |   |   | 1                     |   |    |    |    |    |    |    | 2  |    |    |    |    |    |    |    | 3  |    |    |    |    |    |    |    |
|----------------|------------------------------|---|---|---|---|---|---|---|-----------------------|---|----|----|----|----|----|----|----|----|----|----|----|----|----|----|----|----|----|----|----|----|----|----|
| Bit            | 0                            | 1 | 2 | 3 | 4 | 5 | 6 | 7 | 8                     | 9 | 10 | 11 | 12 | 13 | 14 | 15 | 16 | 17 | 18 | 19 | 20 | 21 | 22 | 23 | 24 | 25 | 26 | 27 | 28 | 29 | 30 | 31 |
|                | Cloud UUID                   |   |   |   |   |   |   |   |                       |   |    |    |    |    |    |    |    |    |    |    |    |    |    |    |    |    |    |    |    |    |    |    |
|                | Cloud UUID, continued        |   |   |   |   |   |   |   |                       |   |    |    |    |    |    |    |    |    |    |    |    |    |    |    |    |    |    |    |    |    |    |    |
|                | Cloud UUID, continued        |   |   |   |   |   |   |   |                       |   |    |    |    |    |    |    |    |    |    |    |    |    |    |    |    |    |    |    |    |    |    |    |
|                | Cloud UUID, continued        |   |   |   |   |   |   |   |                       |   |    |    |    |    |    |    |    |    |    |    |    |    |    |    |    |    |    |    |    |    |    |    |
|                | Malware Event Timestamp      |   |   |   |   |   |   |   |                       |   |    |    |    |    |    |    |    |    |    |    |    |    |    |    |    |    |    |    |    |    |    |    |
|                | Event Type ID                |   |   |   |   |   |   |   |                       |   |    |    |    |    |    |    |    |    |    |    |    |    |    |    |    |    |    |    |    |    |    |    |
|                | Event Subtype ID             |   |   |   |   |   |   |   |                       |   |    |    |    |    |    |    |    |    |    |    |    |    |    |    |    |    |    |    |    |    |    |    |
| Detection Name | Detector ID                  |   |   |   |   |   |   |   | String Block Type (0) |   |    |    |    |    |    |    |    |    |    |    |    |    |    |    |    |    |    |    |    |    |    |    |
|                | String Block Type (0), cont. |   |   |   |   |   |   |   | String Block Length   |   |    |    |    |    |    |    |    |    |    |    |    |    |    |    |    |    |    |    |    |    |    |    |
|                | String Block Length, cont.   |   |   |   |   |   |   |   | Detection Name...     |   |    |    |    |    |    |    |    |    |    |    |    |    |    |    |    |    |    |    |    |    |    |    |
| User           | String Block Type (0)        |   |   |   |   |   |   |   |                       |   |    |    |    |    |    |    |    |    |    |    |    |    |    |    |    |    |    |    |    |    |    |    |
|                | String Block Length          |   |   |   |   |   |   |   |                       |   |    |    |    |    |    |    |    |    |    |    |    |    |    |    |    |    |    |    |    |    |    |    |
|                | User...                      |   |   |   |   |   |   |   |                       |   |    |    |    |    |    |    |    |    |    |    |    |    |    |    |    |    |    |    |    |    |    |    |
| File Name      | String Block Type (0)        |   |   |   |   |   |   |   |                       |   |    |    |    |    |    |    |    |    |    |    |    |    |    |    |    |    |    |    |    |    |    |    |
|                | String Block Length          |   |   |   |   |   |   |   |                       |   |    |    |    |    |    |    |    |    |    |    |    |    |    |    |    |    |    |    |    |    |    |    |
|                | File Name...                 |   |   |   |   |   |   |   |                       |   |    |    |    |    |    |    |    |    |    |    |    |    |    |    |    |    |    |    |    |    |    |    |
| File Path      | String Block Type (0)        |   |   |   |   |   |   |   |                       |   |    |    |    |    |    |    |    |    |    |    |    |    |    |    |    |    |    |    |    |    |    |    |
|                | String Block Length          |   |   |   |   |   |   |   |                       |   |    |    |    |    |    |    |    |    |    |    |    |    |    |    |    |    |    |    |    |    |    |    |
|                | File Path...                 |   |   |   |   |   |   |   |                       |   |    |    |    |    |    |    |    |    |    |    |    |    |    |    |    |    |    |    |    |    |    |    |
| File SHA Hash  | String Block Type (0)        |   |   |   |   |   |   |   |                       |   |    |    |    |    |    |    |    |    |    |    |    |    |    |    |    |    |    |    |    |    |    |    |
|                | String Block Length          |   |   |   |   |   |   |   |                       |   |    |    |    |    |    |    |    |    |    |    |    |    |    |    |    |    |    |    |    |    |    |    |
|                | File SHA Hash...             |   |   |   |   |   |   |   |                       |   |    |    |    |    |    |    |    |    |    |    |    |    |    |    |    |    |    |    |    |    |    |    |
|                | File Size                    |   |   |   |   |   |   |   |                       |   |    |    |    |    |    |    |    |    |    |    |    |    |    |    |    |    |    |    |    |    |    |    |
|                | File Type                    |   |   |   |   |   |   |   |                       |   |    |    |    |    |    |    |    |    |    |    |    |    |    |    |    |    |    |    |    |    |    |    |
|                | File Timestamp               |   |   |   |   |   |   |   |                       |   |    |    |    |    |    |    |    |    |    |    |    |    |    |    |    |    |    |    |    |    |    |    |

| Byte                              | 0                       |   |   |   |   |   |   |                            | 1 |   |    |    |    |    |    |                    | 2  |    |    |    |    |    |    |    | 3  |    |    |    |    |    |    |    |
|-----------------------------------|-------------------------|---|---|---|---|---|---|----------------------------|---|---|----|----|----|----|----|--------------------|----|----|----|----|----|----|----|----|----|----|----|----|----|----|----|----|
|                                   | 0                       | 1 | 2 | 3 | 4 | 5 | 6 | 7                          | 8 | 9 | 10 | 11 | 12 | 13 | 14 | 15                 | 16 | 17 | 18 | 19 | 20 | 21 | 22 | 23 | 24 | 25 | 26 | 27 | 28 | 29 | 30 | 31 |
| Parent File Name                  | String Block Type (0)   |   |   |   |   |   |   |                            |   |   |    |    |    |    |    |                    |    |    |    |    |    |    |    |    |    |    |    |    |    |    |    |    |
|                                   | String Block Length     |   |   |   |   |   |   |                            |   |   |    |    |    |    |    |                    |    |    |    |    |    |    |    |    |    |    |    |    |    |    |    |    |
|                                   | Parent File Name...     |   |   |   |   |   |   |                            |   |   |    |    |    |    |    |                    |    |    |    |    |    |    |    |    |    |    |    |    |    |    |    |    |
| Parent File SHA Hash              | String Block Type (0)   |   |   |   |   |   |   |                            |   |   |    |    |    |    |    |                    |    |    |    |    |    |    |    |    |    |    |    |    |    |    |    |    |
|                                   | String Block Length     |   |   |   |   |   |   |                            |   |   |    |    |    |    |    |                    |    |    |    |    |    |    |    |    |    |    |    |    |    |    |    |    |
|                                   | Parent File SHA Hash... |   |   |   |   |   |   |                            |   |   |    |    |    |    |    |                    |    |    |    |    |    |    |    |    |    |    |    |    |    |    |    |    |
| Event Description                 | String Block Type (0)   |   |   |   |   |   |   |                            |   |   |    |    |    |    |    |                    |    |    |    |    |    |    |    |    |    |    |    |    |    |    |    |    |
|                                   | String Block Length     |   |   |   |   |   |   |                            |   |   |    |    |    |    |    |                    |    |    |    |    |    |    |    |    |    |    |    |    |    |    |    |    |
|                                   | Event Description...    |   |   |   |   |   |   |                            |   |   |    |    |    |    |    |                    |    |    |    |    |    |    |    |    |    |    |    |    |    |    |    |    |
| Device ID                         |                         |   |   |   |   |   |   |                            |   |   |    |    |    |    |    |                    |    |    |    |    |    |    |    |    |    |    |    |    |    |    |    |    |
| Connection Instance               |                         |   |   |   |   |   |   |                            |   |   |    |    |    |    |    | Connection Counter |    |    |    |    |    |    |    |    |    |    |    |    |    |    |    |    |
| Connection Event Timestamp        |                         |   |   |   |   |   |   |                            |   |   |    |    |    |    |    |                    |    |    |    |    |    |    |    |    |    |    |    |    |    |    |    |    |
| Direction                         |                         |   |   |   |   |   |   | Source IP Address          |   |   |    |    |    |    |    |                    |    |    |    |    |    |    |    |    |    |    |    |    |    |    |    |    |
| Source IP Address, continued      |                         |   |   |   |   |   |   |                            |   |   |    |    |    |    |    |                    |    |    |    |    |    |    |    |    |    |    |    |    |    |    |    |    |
| Source IP Address, continued      |                         |   |   |   |   |   |   |                            |   |   |    |    |    |    |    |                    |    |    |    |    |    |    |    |    |    |    |    |    |    |    |    |    |
| Source IP Address, continued      |                         |   |   |   |   |   |   |                            |   |   |    |    |    |    |    |                    |    |    |    |    |    |    |    |    |    |    |    |    |    |    |    |    |
| Source IP, cont.                  |                         |   |   |   |   |   |   | Destination IP Address     |   |   |    |    |    |    |    |                    |    |    |    |    |    |    |    |    |    |    |    |    |    |    |    |    |
| Destination IP Address, continued |                         |   |   |   |   |   |   |                            |   |   |    |    |    |    |    |                    |    |    |    |    |    |    |    |    |    |    |    |    |    |    |    |    |
| Destination IP Address, continued |                         |   |   |   |   |   |   |                            |   |   |    |    |    |    |    |                    |    |    |    |    |    |    |    |    |    |    |    |    |    |    |    |    |
| Destination IP Address, continued |                         |   |   |   |   |   |   |                            |   |   |    |    |    |    |    |                    |    |    |    |    |    |    |    |    |    |    |    |    |    |    |    |    |
| Destination IP, cont              |                         |   |   |   |   |   |   | Application ID             |   |   |    |    |    |    |    |                    |    |    |    |    |    |    |    |    |    |    |    |    |    |    |    |    |
| App. ID, cont.                    |                         |   |   |   |   |   |   | User ID                    |   |   |    |    |    |    |    |                    |    |    |    |    |    |    |    |    |    |    |    |    |    |    |    |    |
| User ID, cont.                    |                         |   |   |   |   |   |   | Access Control Policy UUID |   |   |    |    |    |    |    |                    |    |    |    |    |    |    |    |    |    |    |    |    |    |    |    |    |

|      |                                       |   |   |   |   |   |   |   |             |   |    |    |    |    |    |    |                     |    |    |    |    |    |    |    |                     |    |    |    |    |    |    |    |
|------|---------------------------------------|---|---|---|---|---|---|---|-------------|---|----|----|----|----|----|----|---------------------|----|----|----|----|----|----|----|---------------------|----|----|----|----|----|----|----|
| Byte | 0                                     |   |   |   |   |   |   |   | 1           |   |    |    |    |    |    |    | 2                   |    |    |    |    |    |    |    | 3                   |    |    |    |    |    |    |    |
| Bit  | 0                                     | 1 | 2 | 3 | 4 | 5 | 6 | 7 | 8           | 9 | 10 | 11 | 12 | 13 | 14 | 15 | 16                  | 17 | 18 | 19 | 20 | 21 | 22 | 23 | 24                  | 25 | 26 | 27 | 28 | 29 | 30 | 31 |
|      | Access Control Policy UUID, continued |   |   |   |   |   |   |   |             |   |    |    |    |    |    |    |                     |    |    |    |    |    |    |    |                     |    |    |    |    |    |    |    |
|      | Access Control Policy UUID, continued |   |   |   |   |   |   |   |             |   |    |    |    |    |    |    |                     |    |    |    |    |    |    |    |                     |    |    |    |    |    |    |    |
|      | Access Control Policy UUID, continued |   |   |   |   |   |   |   |             |   |    |    |    |    |    |    |                     |    |    |    |    |    |    |    |                     |    |    |    |    |    |    |    |
| URI  | AC Pol UUID, cont.                    |   |   |   |   |   |   |   | Disposition |   |    |    |    |    |    |    | Retro. Disposition  |    |    |    |    |    |    |    | Str. Block Type (0) |    |    |    |    |    |    |    |
|      | String Block Type (0), continued      |   |   |   |   |   |   |   |             |   |    |    |    |    |    |    |                     |    |    |    |    |    |    |    | String Block Length |    |    |    |    |    |    |    |
|      | String Block Length, continued        |   |   |   |   |   |   |   |             |   |    |    |    |    |    |    |                     |    |    |    |    |    |    |    | URI...              |    |    |    |    |    |    |    |
|      | Source Port                           |   |   |   |   |   |   |   |             |   |    |    |    |    |    |    | Destination Port    |    |    |    |    |    |    |    |                     |    |    |    |    |    |    |    |
|      | Source Country                        |   |   |   |   |   |   |   |             |   |    |    |    |    |    |    | Destination Country |    |    |    |    |    |    |    |                     |    |    |    |    |    |    |    |
|      | Web Application ID                    |   |   |   |   |   |   |   |             |   |    |    |    |    |    |    |                     |    |    |    |    |    |    |    |                     |    |    |    |    |    |    |    |
|      | Client Application ID                 |   |   |   |   |   |   |   |             |   |    |    |    |    |    |    |                     |    |    |    |    |    |    |    |                     |    |    |    |    |    |    |    |
|      | Action                                |   |   |   |   |   |   |   | Protocol    |   |    |    |    |    |    |    | Threat Score        |    |    |    |    |    |    |    | IOC Number          |    |    |    |    |    |    |    |
|      | IOC Number, cont.                     |   |   |   |   |   |   |   |             |   |    |    |    |    |    |    |                     |    |    |    |    |    |    |    |                     |    |    |    |    |    |    |    |

The following table describes the fields in the malware event data block.

**Table B-10** Malware Event Data Block for 5.3 Fields

| Field                      | Data Type | Description                                                                                                                                                                     |
|----------------------------|-----------|---------------------------------------------------------------------------------------------------------------------------------------------------------------------------------|
| Malware Event Block Type   | uint32    | Initiates a malware event data block. This value is always 35.                                                                                                                  |
| Malware Event Block Length | uint32    | Total number of bytes in the malware event data block, including eight bytes for the malware event block type and length fields, plus the number of bytes of data that follows. |
| Agent UUID                 | uint8[16] | The internal unique ID of the FireAMP agent reporting the malware event.                                                                                                        |
| Cloud UUID                 | uint8[16] | The internal unique ID of the malware awareness network from which the malware event originated.                                                                                |
| Malware Event Timestamp    | uint32    | The malware event generation timestamp.                                                                                                                                         |
| Event Type ID              | uint32    | The internal ID of the malware event type.                                                                                                                                      |
| Event Subtype ID           | uint32    | The internal ID of the action that led to malware detection.                                                                                                                    |
| Detector ID                | uint8     | The internal ID of the detection technology that detected the malware.                                                                                                          |

Table B-10 Malware Event Data Block for 5.3 Fields (continued)

| Field               | Data Type | Description                                                                                                                                                                                                  |
|---------------------|-----------|--------------------------------------------------------------------------------------------------------------------------------------------------------------------------------------------------------------|
| String Block Type   | uint32    | Initiates a String data block containing the detection name. This value is always 0.                                                                                                                         |
| String Block Length | uint32    | The number of bytes included in the Detection Name String data block, including eight bytes for the block type and header fields plus the number of bytes in the Detection Name field.                       |
| Detection Name      | string    | The name of the detected or quarantined malware.                                                                                                                                                             |
| String Block Type   | uint32    | Initiates a String data block containing the username. This value is always 0.                                                                                                                               |
| String Block Length | uint32    | The number of bytes included in the User String data block, including eight bytes for the block type and header fields plus the number of bytes in the User field.                                           |
| User                | string    | The user of the computer where the Cisco Agent is installed and where the malware event occurred. Note that these users are not tied to user discovery.                                                      |
| String Block Type   | uint32    | Initiates a String data block containing the file name. This value is always 0.                                                                                                                              |
| String Block Length | uint32    | The number of bytes included in the File Name String data block, including eight bytes for the block type and header fields plus the number of bytes in the File Name field.                                 |
| File Name           | string    | The name of the detected or quarantined file.                                                                                                                                                                |
| String Block Type   | uint32    | Initiates a String data block containing the file path. This value is always 0.                                                                                                                              |
| String Block Length | uint32    | The number of bytes included in the File Path String data block, including eight bytes for the block type and header fields plus the number of bytes in the File Path field.                                 |
| File Path           | string    | The file path, not including the file name, of the detected or quarantined file.                                                                                                                             |
| String Block Type   | uint32    | Initiates a String data block containing the file SHA hash. This value is always 0.                                                                                                                          |
| String Block Length | uint32    | The number of bytes included in the File SHA Hash String data block, including eight bytes for the block type and header fields plus the number of bytes in the File SHA Hash field.                         |
| File SHA Hash       | string    | The rendered string of the SHA-256 hash value of the detected or quarantined file.                                                                                                                           |
| File Size           | uint32    | The size in bytes of the detected or quarantined file.                                                                                                                                                       |
| File Type           | uint32    | The file type of the detected or quarantined file. The meaning of this field is transmitted in the metadata with this event. See <a href="#">FireAMP File Type Metadata, page 3-35</a> for more information. |
| File Timestamp      | uint32    | UNIX timestamp (seconds since 01/01/1970) of the creation of the detected or quarantined file.                                                                                                               |

Table B-10 Malware Event Data Block for 5.3 Fields (continued)

| Field                      | Data Type | Description                                                                                                                                                                                                                                                                         |
|----------------------------|-----------|-------------------------------------------------------------------------------------------------------------------------------------------------------------------------------------------------------------------------------------------------------------------------------------|
| String Block Type          | uint32    | Initiates a String data block containing the parent file name. This value is always 0.                                                                                                                                                                                              |
| String Block Length        | uint32    | The number of bytes included in the Parent File Name String data block, including eight bytes for the block type and header fields plus the number of bytes in the Parent File Name field.                                                                                          |
| Parent File Name           | string    | The name of the file accessing the detected or quarantined file when detection occurred.                                                                                                                                                                                            |
| String Block Type          | uint32    | Initiates a String data block containing the parent file SHA hash. This value is always 0.                                                                                                                                                                                          |
| String Block Length        | uint32    | The number of bytes included in the Parent File SHA Hash String data block, including eight bytes for the block type and header fields plus the number of bytes in the Parent File SHA Hash field.                                                                                  |
| Parent File SHA Hash       | string    | The SHA-256 hash value of the parent file accessing the detected or quarantined file when detection occurred.                                                                                                                                                                       |
| String Block Type          | uint32    | Initiates a String data block containing the event description. This value is always 0.                                                                                                                                                                                             |
| String Block Length        | uint32    | The number of bytes included in the Event Description String data block, including eight bytes for the block type and header fields plus the number of bytes in the Event Description field.                                                                                        |
| Event Description          | string    | The additional event information associated with the event type.                                                                                                                                                                                                                    |
| Device ID                  | uint32    | ID for the device that generated the event.                                                                                                                                                                                                                                         |
| Connection Instance        | uint16    | Snort instance on the device that generated the event. Used to link the event with a connection or IDS event.                                                                                                                                                                       |
| Connection Counter         | uint16    | Value used to distinguish between connection events that happen during the same second.                                                                                                                                                                                             |
| Connection Event Timestamp | uint32    | Timestamp of the connection event.                                                                                                                                                                                                                                                  |
| Direction                  | uint8     | Indicates whether the file was uploaded or downloaded. Can have the following values: <ul style="list-style-type: none"> <li>• 1 - Download</li> <li>• 2 - Upload</li> </ul> Currently the value depends on the protocol (for example, if the connection is HTTP it is a download). |
| Source IP Address          | uint8[16] | IPv4 or IPv6 address for the source of the connection.                                                                                                                                                                                                                              |
| Destination IP Address     | uint8[16] | IPv4 or IPv6 address for the destination of the connection.                                                                                                                                                                                                                         |
| Application ID             | uint32    | ID number that maps to the application using the file transfer.                                                                                                                                                                                                                     |

Table B-10 Malware Event Data Block for 5.3 Fields (continued)

| Field                      | Data Type | Description                                                                                                                                                                                                                                                                                                                                                                                                                                                                                                                                                                                       |
|----------------------------|-----------|---------------------------------------------------------------------------------------------------------------------------------------------------------------------------------------------------------------------------------------------------------------------------------------------------------------------------------------------------------------------------------------------------------------------------------------------------------------------------------------------------------------------------------------------------------------------------------------------------|
| User ID                    | uint32    | Identification number for the user logged into the destination host, as identified by the system.                                                                                                                                                                                                                                                                                                                                                                                                                                                                                                 |
| Access Control Policy UUID | uint8[16] | Identification number that acts as a unique identifier for the access control policy that triggered the event.                                                                                                                                                                                                                                                                                                                                                                                                                                                                                    |
| Disposition                | uint8     | The malware status of the file. Possible values include: <ul style="list-style-type: none"> <li>• 1 - CLEAN The file is clean and does not contain malware.</li> <li>• 2 - UNKNOWN It is unknown whether the file contains malware.</li> <li>• 3 - MALWARE The file contains malware.</li> <li>• 4 - UNAVAILABLE The software was unable to send a request to the Cisco cloud for a disposition, or the Cisco cloud services did not respond to the request.</li> <li>• 5 - CUSTOM SIGNATURE The file matches a user-defined hash, and is treated in a fashion designated by the user.</li> </ul> |
| Retrospective Disposition  | uint8     | Disposition of the file if the disposition is updated. If the disposition is not updated, this field contains the same value as the Disposition field. The possible values are the same as the Disposition field.                                                                                                                                                                                                                                                                                                                                                                                 |
| String Block Type          | uint32    | Initiates a String data block containing the URI. This value is always 0.                                                                                                                                                                                                                                                                                                                                                                                                                                                                                                                         |
| String Block Length        | uint32    | The number of bytes included in the URI data block, including eight bytes for the block type and header fields plus the number of bytes in the URI field.                                                                                                                                                                                                                                                                                                                                                                                                                                         |
| URI                        | string    | URI of the connection.                                                                                                                                                                                                                                                                                                                                                                                                                                                                                                                                                                            |
| Source Port                | uint16    | Port number for the source of the connection.                                                                                                                                                                                                                                                                                                                                                                                                                                                                                                                                                     |
| Destination Port           | uint16    | Port number for the destination of the connection.                                                                                                                                                                                                                                                                                                                                                                                                                                                                                                                                                |
| Source Country             | uint16    | Code for the country of the source host.                                                                                                                                                                                                                                                                                                                                                                                                                                                                                                                                                          |
| Destination Country        | uint 16   | Code for the country of the destination host.                                                                                                                                                                                                                                                                                                                                                                                                                                                                                                                                                     |
| Web Application ID         | uint32    | The internal identification number of the detected web application, if applicable.                                                                                                                                                                                                                                                                                                                                                                                                                                                                                                                |
| Client Application ID      | uint32    | The internal identification number of the detected client application, if applicable.                                                                                                                                                                                                                                                                                                                                                                                                                                                                                                             |

Table B-10 Malware Event Data Block for 5.3 Fields (continued)

| Field        | Data Type | Description                                                                                                                                                                                                                                                               |
|--------------|-----------|---------------------------------------------------------------------------------------------------------------------------------------------------------------------------------------------------------------------------------------------------------------------------|
| Action       | uint8     | The action taken on the file based on the file type. Can have the following values: <ul style="list-style-type: none"> <li>• 1 - Detect</li> <li>• 2 - Block</li> <li>• 3 - Malware Cloud Lookup</li> <li>• 4 - Malware Block</li> <li>• 5 - Malware Whitelist</li> </ul> |
| Protocol     | uint8     | IANA protocol number specified by the user. For example: <ul style="list-style-type: none"> <li>• 1 - ICMP</li> <li>• 4 - IP</li> <li>• 6 - TCP</li> <li>• 17 - UDP</li> </ul> This is currently only TCP.                                                                |
| Threat Score | uint8     | A numeric value from 0 to 100 based on the potentially malicious behaviors observed during dynamic analysis.                                                                                                                                                              |
| IOC Number   | uint16    | ID Number of the compromise associated with this event.                                                                                                                                                                                                                   |

## Legacy Discovery Data Structures

See the following sections for more information:

- [Legacy Discovery Event Header, page B-55](#)
- [Legacy Server Data Blocks, page B-57](#)
- [Legacy Client Application Data Blocks, page B-58](#)
- [Legacy Scan Result Data Blocks, page B-60](#)
- [Legacy Host Profile Data Blocks, page B-70](#)
- [Legacy OS Fingerprint Data Blocks, page B-77](#)

## Legacy Discovery Event Header

### Discovery Event Header 5.0 - 5.1.1.x

Discovery and connection event messages contain a discovery event header. It conveys the type and subtype of the event, the time the event occurred, the device on which the event occurred, and the structure of the event data in the message. This header is followed by the actual host discovery, user, or connection event data. The structures associated with the different event type/subtype values are described in [Host Discovery Structures by Event Type, page 4-37](#).

The event type and event subtype fields of the discovery event header identify the structure of the transmitted event message. After the structure of the event data block is determined, your program can parse the message appropriately.

The shaded rows in the following diagram illustrate the format of the discovery event header.

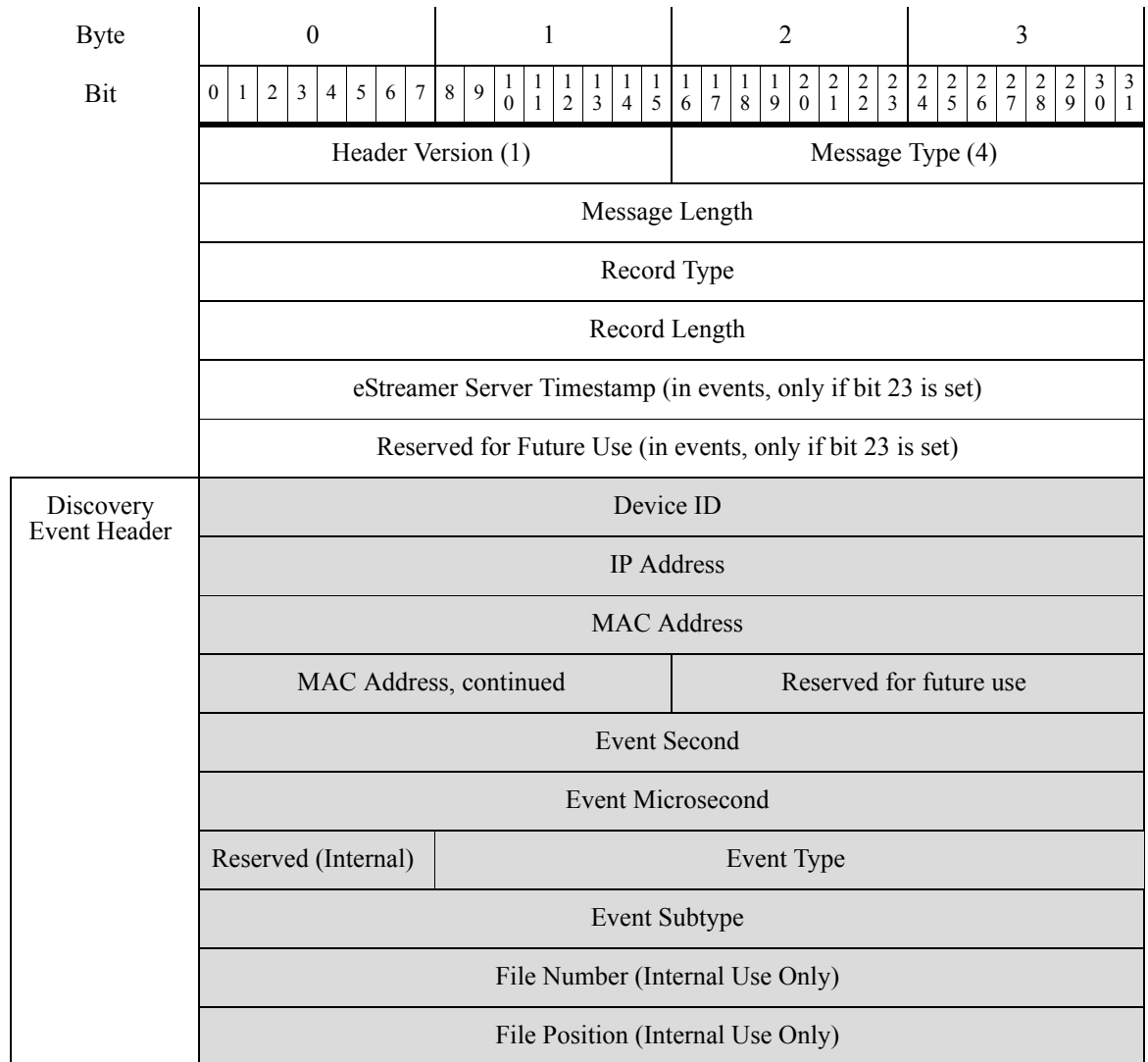

The following table describes the discovery event header.

**Table B-11** Discovery Event Header Fields

| Field      | Data Types | Description                                                                                                                                                                                                                        |
|------------|------------|------------------------------------------------------------------------------------------------------------------------------------------------------------------------------------------------------------------------------------|
| Device ID  | uint32     | ID number of the device that generated the discovery event. You can obtain the metadata for the device by requesting Version 3 and 4 metadata. See <a href="#">Managed Device Record Metadata, page 3-30</a> for more information. |
| IP Address | uint32     | IP address of the host involved in the event.                                                                                                                                                                                      |



Table B-11 Discovery Event Header Fields (continued)

| Field                   | Data Types | Description                                                                                                                                                                                                                   |
|-------------------------|------------|-------------------------------------------------------------------------------------------------------------------------------------------------------------------------------------------------------------------------------|
| MAC Address             | uint8[6]   | MAC address of the host involved in the event.                                                                                                                                                                                |
| Reserved for future use | byte[2]    | Two bytes of padding with values set to 0.                                                                                                                                                                                    |
| Event Second            | uint32     | UNIX timestamp (seconds since 01/01/1970) that the system generated the event.                                                                                                                                                |
| Event Microsecond       | uint32     | Microsecond (one millionth of a second) increment that the system generated the event.                                                                                                                                        |
| Reserved (Internal)     | byte       | Internal data from Cisco and can be disregarded.                                                                                                                                                                              |
| Event Type              | uint32     | Event type (1000 for new events, 1001 for change events, 1002 for user input events, 1050 for full host profile). See <a href="#">Host Discovery Structures by Event Type, page 4-37</a> for a list of available event types. |
| Event Subtype           | uint32     | Event subtype. See <a href="#">Host Discovery Structures by Event Type, page 4-37</a> for a list of available event subtypes.                                                                                                 |
| File Number             | byte[4]    | Serial file number. This field is for Cisco internal use and can be disregarded.                                                                                                                                              |
| File Position           | byte[4]    | Event's position in the serial file. This field is for Cisco internal use and can be disregarded.                                                                                                                             |

## Legacy Server Data Blocks

For more information, see the following section:

- [Attribute Address Data Block for 5.0 - 5.1.1.x, page B-57](#)

### Attribute Address Data Block for 5.0 - 5.1.1.x

The Attribute Address data block contains an attribute list item and is used within an Attribute Definition data block. It has a block type of 38.

The following diagram shows the basic structure of an Attribute Address data block:

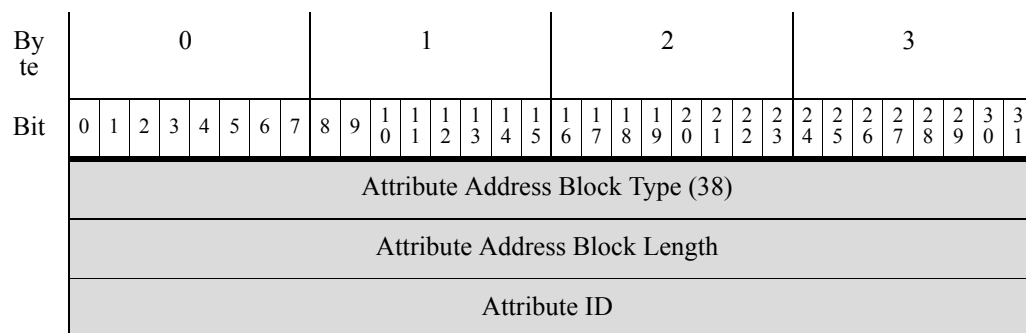

|            |
|------------|
| IP Address |
| Bits       |

The following table describes the fields of the Attribute Address data block.

**Table B-12** Attribute Address Data Block Fields

| Field                          | Data Type | Description                                                                                                                                                                                      |
|--------------------------------|-----------|--------------------------------------------------------------------------------------------------------------------------------------------------------------------------------------------------|
| Attribute Address Block Type   | uint32    | Initiates an Attribute Address data block. This value is always 38.                                                                                                                              |
| Attribute Address Block Length | uint32    | Number of bytes in the Attribute Address data block, including eight bytes for the attribute address block type and length, plus the number of bytes in the attribute address data that follows. |
| Attribute ID                   | uint32    | Identification number of the affected attribute, if applicable.                                                                                                                                  |
| IP Address                     | uint8[4]  | IP address of the host, if the address was automatically assigned, in IP address octets.                                                                                                         |
| Bits                           | uint32    | Contains the significant bits used to calculate the netmask if an IP address was automatically assigned.                                                                                         |

## Legacy Client Application Data Blocks

For more information, see the following section:

- [User Client Application Data Block for 5.0 - 5.1, page B-58](#)

### User Client Application Data Block for 5.0 - 5.1

The User Client Application data block contains information about the source of the client application data, the identification number for the user who added the data, and the lists of IP address range data blocks. The User Client Application data block has a block type of 59.

The following diagram shows the basic structure of a User Client Application data block:

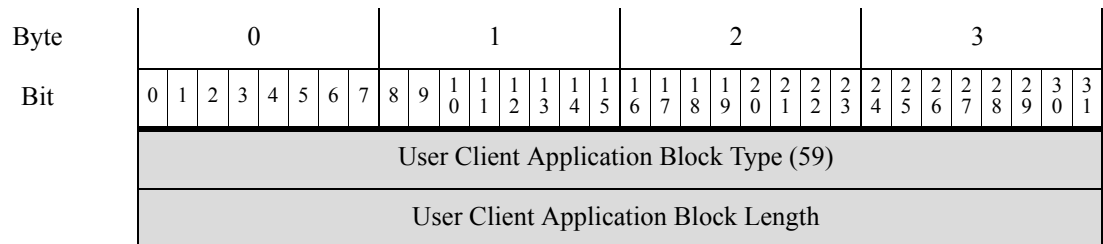

|                   |                                     |
|-------------------|-------------------------------------|
| IP Address Ranges | Generic List Block Type (31)        |
|                   | Generic List Block Length           |
|                   | IP Range Specification Data Blocks* |
|                   | Application Protocol ID             |
|                   | Client Application ID               |
| Version           | String Block Type (0)               |
|                   | String Block Length                 |
|                   | Version...                          |

The following table describes the fields of the User Client Application data block.

**Table B-13** User Client Application Data Block Fields

| Field                                | Number of Bytes | Description                                                                                                                                                                                                                 |
|--------------------------------------|-----------------|-----------------------------------------------------------------------------------------------------------------------------------------------------------------------------------------------------------------------------|
| User Client Application Block Type   | uint32          | Initiates a User Client Application data block. This value is always 59.                                                                                                                                                    |
| User Client Application Block Length | uint32          | Total number of bytes in the User Client Application data block, including eight bytes for the user client application block type and length fields, plus the number of bytes of user client application data that follows. |
| Generic List Block Type              | uint32          | Initiates a Generic List data block comprising IP Range Specification data blocks conveying IP address range data. This value is always 31.                                                                                 |
| Generic List Block Length            | uint32          | Number of bytes in the Generic List data block, including the list header and all encapsulated IP Range Specification data blocks.                                                                                          |
| IP Range Specification Data Blocks * | variable        | IP Range Specification data blocks containing information about the IP address ranges for the user input. See <a href="#">Table 4-56 User Server Data Block Fields, page 4-96</a> for a description of this data block.     |
| Application Protocol ID              | uint32          | The internal identification number for the application protocol, if applicable.                                                                                                                                             |
| Client Application ID                | uint32          | The internal identification number of the detected client application, if applicable.                                                                                                                                       |
| String Block Type                    | uint32          | Initiates a String data block that contains the client application version. This value is always 0.                                                                                                                         |
| String Block Length                  | uint32          | Number of bytes in the client application version String data block, including the string block type and length fields, plus the number of bytes in the version.                                                            |
| Version                              | string          | Client application version.                                                                                                                                                                                                 |

# Legacy Scan Result Data Blocks

For more information, see the following sections:

- [Scan Result Data Block 5.0 - 5.1.1.x](#), page B-60
- [User Product Data Block for 5.0.x](#), page B-62

## Scan Result Data Block 5.0 - 5.1.1.x

The Scan Result data block describes a vulnerability and is used within Add Scan Result events (event type 1002, subtype 11). The Scan Result data block has a block type of 102.

The following diagram shows the format of a Scan Result data block:

| Byte               | 0                                     |   |   |   |   |   |   |   | 1 |   |    |    |    |    |    |    | 2                                   |    |    |    |    |    |    |    | 3  |    |    |    |    |    |    |    |                           |
|--------------------|---------------------------------------|---|---|---|---|---|---|---|---|---|----|----|----|----|----|----|-------------------------------------|----|----|----|----|----|----|----|----|----|----|----|----|----|----|----|---------------------------|
| Bit                | 0                                     | 1 | 2 | 3 | 4 | 5 | 6 | 7 | 8 | 9 | 10 | 11 | 12 | 13 | 14 | 15 | 16                                  | 17 | 18 | 19 | 20 | 21 | 22 | 23 | 24 | 25 | 26 | 27 | 28 | 29 | 30 | 31 |                           |
|                    | Scan Result Block Type (102)          |   |   |   |   |   |   |   |   |   |    |    |    |    |    |    |                                     |    |    |    |    |    |    |    |    |    |    |    |    |    |    |    |                           |
|                    | Scan Result Block Length              |   |   |   |   |   |   |   |   |   |    |    |    |    |    |    |                                     |    |    |    |    |    |    |    |    |    |    |    |    |    |    |    |                           |
|                    | User ID                               |   |   |   |   |   |   |   |   |   |    |    |    |    |    |    |                                     |    |    |    |    |    |    |    |    |    |    |    |    |    |    |    |                           |
|                    | Scan Type                             |   |   |   |   |   |   |   |   |   |    |    |    |    |    |    |                                     |    |    |    |    |    |    |    |    |    |    |    |    |    |    |    |                           |
|                    | IP Address                            |   |   |   |   |   |   |   |   |   |    |    |    |    |    |    |                                     |    |    |    |    |    |    |    |    |    |    |    |    |    |    |    |                           |
|                    | Port                                  |   |   |   |   |   |   |   |   |   |    |    |    |    |    |    | Protocol                            |    |    |    |    |    |    |    |    |    |    |    |    |    |    |    |                           |
|                    | Flag                                  |   |   |   |   |   |   |   |   |   |    |    |    |    |    |    | List Block Type (11)                |    |    |    |    |    |    |    |    |    |    |    |    |    |    |    | Scan Vulnerability List   |
|                    | List Block Type (11)                  |   |   |   |   |   |   |   |   |   |    |    |    |    |    |    | List Block Length                   |    |    |    |    |    |    |    |    |    |    |    |    |    |    |    |                           |
| Vulnerability List | List Block Length                     |   |   |   |   |   |   |   |   |   |    |    |    |    |    |    | Scan Vulnerability Block Type (109) |    |    |    |    |    |    |    |    |    |    |    |    |    |    |    |                           |
|                    | Scan Vulnerability Block Type (109)   |   |   |   |   |   |   |   |   |   |    |    |    |    |    |    | Scan Vulnerability Block Length     |    |    |    |    |    |    |    |    |    |    |    |    |    |    |    |                           |
|                    | Scan Vulnerability Block Length       |   |   |   |   |   |   |   |   |   |    |    |    |    |    |    | Vulnerability Data...               |    |    |    |    |    |    |    |    |    |    |    |    |    |    |    |                           |
|                    | List Block Type (11)                  |   |   |   |   |   |   |   |   |   |    |    |    |    |    |    |                                     |    |    |    |    |    |    |    |    |    |    |    |    |    |    |    | Generic Scan Results List |
|                    | List Block Length                     |   |   |   |   |   |   |   |   |   |    |    |    |    |    |    |                                     |    |    |    |    |    |    |    |    |    |    |    |    |    |    |    |                           |
| Scan Results List  | Generic Scan Results Block Type (108) |   |   |   |   |   |   |   |   |   |    |    |    |    |    |    |                                     |    |    |    |    |    |    |    |    |    |    |    |    |    |    |    |                           |
|                    | Generic Scan Results Block Length     |   |   |   |   |   |   |   |   |   |    |    |    |    |    |    |                                     |    |    |    |    |    |    |    |    |    |    |    |    |    |    |    |                           |
|                    | Generic Scan Results...               |   |   |   |   |   |   |   |   |   |    |    |    |    |    |    |                                     |    |    |    |    |    |    |    |    |    |    |    |    |    |    |    |                           |

|                   |                              |   |   |   |   |   |   |   |   |   |    |    |    |    |    |    |    |    |    |    |    |    |    |    |    |    |    |    |    |    |    |    |
|-------------------|------------------------------|---|---|---|---|---|---|---|---|---|----|----|----|----|----|----|----|----|----|----|----|----|----|----|----|----|----|----|----|----|----|----|
| Byte              | 0                            |   |   |   |   |   |   |   | 1 |   |    |    |    |    |    |    | 2  |    |    |    |    |    |    |    | 3  |    |    |    |    |    |    |    |
| Bit               | 0                            | 1 | 2 | 3 | 4 | 5 | 6 | 7 | 8 | 9 | 10 | 11 | 12 | 13 | 14 | 15 | 16 | 17 | 18 | 19 | 20 | 21 | 22 | 23 | 24 | 25 | 26 | 27 | 28 | 29 | 30 | 31 |
| User Product List | Generic List Block Type (31) |   |   |   |   |   |   |   |   |   |    |    |    |    |    |    |    |    |    |    |    |    |    |    |    |    |    |    |    |    |    |    |
|                   | Generic List Block Length    |   |   |   |   |   |   |   |   |   |    |    |    |    |    |    |    |    |    |    |    |    |    |    |    |    |    |    |    |    |    |    |
|                   | User Product Data Blocks*    |   |   |   |   |   |   |   |   |   |    |    |    |    |    |    |    |    |    |    |    |    |    |    |    |    |    |    |    |    |    |    |

The following table describes the fields of the Scan Result data block.

**Table B-14 Scan Result Data Block Fields**

| Field                           | Data Type | Description                                                                                                                                                                                                                                     |
|---------------------------------|-----------|-------------------------------------------------------------------------------------------------------------------------------------------------------------------------------------------------------------------------------------------------|
| Scan Result Block Type          | uint32    | Initiates a Scan Result data block. This value is always 102.                                                                                                                                                                                   |
| Scan Result Block Length        | uint32    | Number of bytes in the Scan Vulnerability data block, including eight bytes for the scan vulnerability block type and length fields, plus the number of bytes of scan vulnerability data that follows.                                          |
| User ID                         | uint32    | Contains the user identification number for the user who imported the scan result or ran the scan that produced the scan result.                                                                                                                |
| Scan Type                       | uint32    | Indicates how the results were added to the system.                                                                                                                                                                                             |
| IP Address                      | uint32    | IP address of the host affected by the vulnerabilities in the result, in IP address octets.                                                                                                                                                     |
| Port                            | uint16    | Port used by the sub-server affected by the vulnerabilities in the results.                                                                                                                                                                     |
| Protocol                        | uint16    | IANA protocol number. For example: <ul style="list-style-type: none"> <li>• 1 - ICMP</li> <li>• 4 - IP</li> <li>• 6 - TCP</li> <li>• 17 - UDP</li> </ul>                                                                                        |
| Flag                            | uint16    | Reserved                                                                                                                                                                                                                                        |
| List Block Type                 | uint32    | Initiates a List data block comprising Scan Vulnerability data blocks conveying transport Scan Vulnerability data. This value is always 11.                                                                                                     |
| List Block Length               | uint32    | Number of bytes in the list. This number includes the eight bytes of the list block type and length fields, plus all encapsulated Scan Vulnerability data blocks.<br><br>This field is followed by zero or more Scan Vulnerability data blocks. |
| Scan Vulnerability Block Type   | uint32    | Initiates a Scan Vulnerability data block describing a vulnerability detected during a scan. This value is always 109.                                                                                                                          |
| Scan Vulnerability Block Length | uint32    | Number of bytes in the Scan Vulnerability data block, including eight bytes for the scan vulnerability block type and length fields, plus the number of bytes in the scan vulnerability data that follows.                                      |

Table B-14 Scan Result Data Block Fields (continued)

| Field                             | Data Type | Description                                                                                                                                                                                                                                     |
|-----------------------------------|-----------|-------------------------------------------------------------------------------------------------------------------------------------------------------------------------------------------------------------------------------------------------|
| Vulnerability Data                | string    | Information relating to each vulnerability.                                                                                                                                                                                                     |
| List Block Type                   | uint32    | Initiates a List data block comprising Scan Vulnerability data blocks conveying transport Scan Vulnerability data. This value is always 11.                                                                                                     |
| List Block Length                 | uint32    | Number of bytes in the list. This number includes the eight bytes of the list block type and length fields, plus all encapsulated Scan Vulnerability data blocks.<br><br>This field is followed by zero or more Scan Vulnerability data blocks. |
| Generic Scan Results Block Type   | uint32    | Initiates a Generic Scan Results data block describing server and operating system data detected during a scan. This value is always 108.                                                                                                       |
| Generic Scan Results Block Length | uint32    | Number of bytes in the Generic Scan Results data block, including eight bytes for the generic scan results block type and length fields, plus the number of bytes in the scan result data that follows.                                         |
| Generic Scan Results Data         | string    | Information relating to each scan result.                                                                                                                                                                                                       |
| Generic List Block Type           | uint32    | Initiates a Generic List data block comprising User Product data blocks conveying host input data from a third party application. This value is always 31.                                                                                      |
| Generic List Block Length         | uint32    | Number of bytes in the Generic List data block, including the list header and all encapsulated User Product data blocks.                                                                                                                        |
| User Product Data Blocks *        | variable  | User Product data blocks containing host input data. See <a href="#">User Product Data Block 5.1+</a> , page 4-152 for a description of this data block.                                                                                        |

## User Product Data Block for 5.0.x

The User Product data block conveys host input data imported from a third party application, including third party application string mappings. This data block is used in [Scan Result Data Block 5.2+](#), page 4-118. The User Product data block has a block type of 65 for 4.10.x, and a block type of 118 for 5.0 - 5.0.x. The block types have the same structure.



### Note

An asterisk(\*) next to a data block name in the following diagram indicates that multiple instances of the data block may occur.

The following diagram shows the format of the User Product data block:

| Byte                  | 0                                       |   |   |   |   |   |   |   | 1 |   |    |    |    |    |    |    | 2        |    |    |    |    |    |    |    | 3  |    |    |    |    |    |    |    |
|-----------------------|-----------------------------------------|---|---|---|---|---|---|---|---|---|----|----|----|----|----|----|----------|----|----|----|----|----|----|----|----|----|----|----|----|----|----|----|
|                       | 0                                       | 1 | 2 | 3 | 4 | 5 | 6 | 7 | 8 | 9 | 10 | 11 | 12 | 13 | 14 | 15 | 16       | 17 | 18 | 19 | 20 | 21 | 22 | 23 | 24 | 25 | 26 | 27 | 28 | 29 | 30 | 31 |
|                       | User Product Data Block Type (65   118) |   |   |   |   |   |   |   |   |   |    |    |    |    |    |    |          |    |    |    |    |    |    |    |    |    |    |    |    |    |    |    |
|                       | User Product Block Length               |   |   |   |   |   |   |   |   |   |    |    |    |    |    |    |          |    |    |    |    |    |    |    |    |    |    |    |    |    |    |    |
|                       | Source ID                               |   |   |   |   |   |   |   |   |   |    |    |    |    |    |    |          |    |    |    |    |    |    |    |    |    |    |    |    |    |    |    |
|                       | Source Type                             |   |   |   |   |   |   |   |   |   |    |    |    |    |    |    |          |    |    |    |    |    |    |    |    |    |    |    |    |    |    |    |
| IP Address Ranges     | Generic List Block Type (31)            |   |   |   |   |   |   |   |   |   |    |    |    |    |    |    |          |    |    |    |    |    |    |    |    |    |    |    |    |    |    |    |
|                       | Generic List Block Length               |   |   |   |   |   |   |   |   |   |    |    |    |    |    |    |          |    |    |    |    |    |    |    |    |    |    |    |    |    |    |    |
|                       | IP Range Specification Data Blocks*     |   |   |   |   |   |   |   |   |   |    |    |    |    |    |    |          |    |    |    |    |    |    |    |    |    |    |    |    |    |    |    |
|                       | Port                                    |   |   |   |   |   |   |   |   |   |    |    |    |    |    |    | Protocol |    |    |    |    |    |    |    |    |    |    |    |    |    |    |    |
|                       | Drop User Product                       |   |   |   |   |   |   |   |   |   |    |    |    |    |    |    |          |    |    |    |    |    |    |    |    |    |    |    |    |    |    |    |
| Custom Vendor String  | String Block Type (0)                   |   |   |   |   |   |   |   |   |   |    |    |    |    |    |    |          |    |    |    |    |    |    |    |    |    |    |    |    |    |    |    |
|                       | String Block Length                     |   |   |   |   |   |   |   |   |   |    |    |    |    |    |    |          |    |    |    |    |    |    |    |    |    |    |    |    |    |    |    |
|                       | Custom Vendor String...                 |   |   |   |   |   |   |   |   |   |    |    |    |    |    |    |          |    |    |    |    |    |    |    |    |    |    |    |    |    |    |    |
| Custom Product String | String Block Type (0)                   |   |   |   |   |   |   |   |   |   |    |    |    |    |    |    |          |    |    |    |    |    |    |    |    |    |    |    |    |    |    |    |
|                       | String Block Length                     |   |   |   |   |   |   |   |   |   |    |    |    |    |    |    |          |    |    |    |    |    |    |    |    |    |    |    |    |    |    |    |
|                       | Custom Product String...                |   |   |   |   |   |   |   |   |   |    |    |    |    |    |    |          |    |    |    |    |    |    |    |    |    |    |    |    |    |    |    |
| Custom Version String | String Block Type (0)                   |   |   |   |   |   |   |   |   |   |    |    |    |    |    |    |          |    |    |    |    |    |    |    |    |    |    |    |    |    |    |    |
|                       | String Block Length                     |   |   |   |   |   |   |   |   |   |    |    |    |    |    |    |          |    |    |    |    |    |    |    |    |    |    |    |    |    |    |    |
|                       | Custom Version String...                |   |   |   |   |   |   |   |   |   |    |    |    |    |    |    |          |    |    |    |    |    |    |    |    |    |    |    |    |    |    |    |
|                       | Software ID                             |   |   |   |   |   |   |   |   |   |    |    |    |    |    |    |          |    |    |    |    |    |    |    |    |    |    |    |    |    |    |    |
|                       | Server ID                               |   |   |   |   |   |   |   |   |   |    |    |    |    |    |    |          |    |    |    |    |    |    |    |    |    |    |    |    |    |    |    |
|                       | Vendor ID                               |   |   |   |   |   |   |   |   |   |    |    |    |    |    |    |          |    |    |    |    |    |    |    |    |    |    |    |    |    |    |    |
|                       | Product ID                              |   |   |   |   |   |   |   |   |   |    |    |    |    |    |    |          |    |    |    |    |    |    |    |    |    |    |    |    |    |    |    |
| Major Version String  | String Block Type (0)                   |   |   |   |   |   |   |   |   |   |    |    |    |    |    |    |          |    |    |    |    |    |    |    |    |    |    |    |    |    |    |    |
|                       | String Block Length                     |   |   |   |   |   |   |   |   |   |    |    |    |    |    |    |          |    |    |    |    |    |    |    |    |    |    |    |    |    |    |    |
|                       | Major Version String...                 |   |   |   |   |   |   |   |   |   |    |    |    |    |    |    |          |    |    |    |    |    |    |    |    |    |    |    |    |    |    |    |

| Byte                 | 0                          |   |   |   |   |   |   |   | 1 |   |    |    |    |    |    |    | 2  |    |    |    |    |    |    |    | 3  |    |    |    |    |    |    |    |
|----------------------|----------------------------|---|---|---|---|---|---|---|---|---|----|----|----|----|----|----|----|----|----|----|----|----|----|----|----|----|----|----|----|----|----|----|
|                      | 0                          | 1 | 2 | 3 | 4 | 5 | 6 | 7 | 8 | 9 | 10 | 11 | 12 | 13 | 14 | 15 | 16 | 17 | 18 | 19 | 20 | 21 | 22 | 23 | 24 | 25 | 26 | 27 | 28 | 29 | 30 | 31 |
| Minor Version String | String Block Type (0)      |   |   |   |   |   |   |   |   |   |    |    |    |    |    |    |    |    |    |    |    |    |    |    |    |    |    |    |    |    |    |    |
|                      | String Block Length        |   |   |   |   |   |   |   |   |   |    |    |    |    |    |    |    |    |    |    |    |    |    |    |    |    |    |    |    |    |    |    |
|                      | Minor Version String...    |   |   |   |   |   |   |   |   |   |    |    |    |    |    |    |    |    |    |    |    |    |    |    |    |    |    |    |    |    |    |    |
| Revision String      | String Block Type (0)      |   |   |   |   |   |   |   |   |   |    |    |    |    |    |    |    |    |    |    |    |    |    |    |    |    |    |    |    |    |    |    |
|                      | String Block Length        |   |   |   |   |   |   |   |   |   |    |    |    |    |    |    |    |    |    |    |    |    |    |    |    |    |    |    |    |    |    |    |
|                      | Revision String...         |   |   |   |   |   |   |   |   |   |    |    |    |    |    |    |    |    |    |    |    |    |    |    |    |    |    |    |    |    |    |    |
| To Major String      | String Block Type (0)      |   |   |   |   |   |   |   |   |   |    |    |    |    |    |    |    |    |    |    |    |    |    |    |    |    |    |    |    |    |    |    |
|                      | String Block Length        |   |   |   |   |   |   |   |   |   |    |    |    |    |    |    |    |    |    |    |    |    |    |    |    |    |    |    |    |    |    |    |
|                      | To Major Version String... |   |   |   |   |   |   |   |   |   |    |    |    |    |    |    |    |    |    |    |    |    |    |    |    |    |    |    |    |    |    |    |
| To Minor String      | String Block Type (0)      |   |   |   |   |   |   |   |   |   |    |    |    |    |    |    |    |    |    |    |    |    |    |    |    |    |    |    |    |    |    |    |
|                      | String Block Length        |   |   |   |   |   |   |   |   |   |    |    |    |    |    |    |    |    |    |    |    |    |    |    |    |    |    |    |    |    |    |    |
|                      | To Minor Version String... |   |   |   |   |   |   |   |   |   |    |    |    |    |    |    |    |    |    |    |    |    |    |    |    |    |    |    |    |    |    |    |
| To Revision String   | String Block Type (0)      |   |   |   |   |   |   |   |   |   |    |    |    |    |    |    |    |    |    |    |    |    |    |    |    |    |    |    |    |    |    |    |
|                      | String Block Length        |   |   |   |   |   |   |   |   |   |    |    |    |    |    |    |    |    |    |    |    |    |    |    |    |    |    |    |    |    |    |    |
|                      | To Revision String...      |   |   |   |   |   |   |   |   |   |    |    |    |    |    |    |    |    |    |    |    |    |    |    |    |    |    |    |    |    |    |    |
| Build String         | String Block Type (0)      |   |   |   |   |   |   |   |   |   |    |    |    |    |    |    |    |    |    |    |    |    |    |    |    |    |    |    |    |    |    |    |
|                      | String Block Length        |   |   |   |   |   |   |   |   |   |    |    |    |    |    |    |    |    |    |    |    |    |    |    |    |    |    |    |    |    |    |    |
|                      | Build String...            |   |   |   |   |   |   |   |   |   |    |    |    |    |    |    |    |    |    |    |    |    |    |    |    |    |    |    |    |    |    |    |
| Patch String         | String Block Type (0)      |   |   |   |   |   |   |   |   |   |    |    |    |    |    |    |    |    |    |    |    |    |    |    |    |    |    |    |    |    |    |    |
|                      | String Block Length        |   |   |   |   |   |   |   |   |   |    |    |    |    |    |    |    |    |    |    |    |    |    |    |    |    |    |    |    |    |    |    |
|                      | Patch String...            |   |   |   |   |   |   |   |   |   |    |    |    |    |    |    |    |    |    |    |    |    |    |    |    |    |    |    |    |    |    |    |
| Extension String     | String Block Type (0)      |   |   |   |   |   |   |   |   |   |    |    |    |    |    |    |    |    |    |    |    |    |    |    |    |    |    |    |    |    |    |    |
|                      | String Block Length        |   |   |   |   |   |   |   |   |   |    |    |    |    |    |    |    |    |    |    |    |    |    |    |    |    |    |    |    |    |    |    |
|                      | Extension String...        |   |   |   |   |   |   |   |   |   |    |    |    |    |    |    |    |    |    |    |    |    |    |    |    |    |    |    |    |    |    |    |



| Byte          | 0                                                                                                                  |   |   |   |   |   |   |   | 1 |   |    |    |    |    |    |    | 2  |    |    |    |    |    |    |    | 3  |    |    |    |    |    |    |    |
|---------------|--------------------------------------------------------------------------------------------------------------------|---|---|---|---|---|---|---|---|---|----|----|----|----|----|----|----|----|----|----|----|----|----|----|----|----|----|----|----|----|----|----|
|               | 0                                                                                                                  | 1 | 2 | 3 | 4 | 5 | 6 | 7 | 8 | 9 | 10 | 11 | 12 | 13 | 14 | 15 | 16 | 17 | 18 | 19 | 20 | 21 | 22 | 23 | 24 | 25 | 26 | 27 | 28 | 29 | 30 | 31 |
| OS UUID       | Operating System UUID<br>Operating System UUID cont.<br>Operating System UUID cont.<br>Operating System UUID cont. |   |   |   |   |   |   |   |   |   |    |    |    |    |    |    |    |    |    |    |    |    |    |    |    |    |    |    |    |    |    |    |
| List of Fixes | Generic List Block Type (31)                                                                                       |   |   |   |   |   |   |   |   |   |    |    |    |    |    |    |    |    |    |    |    |    |    |    |    |    |    |    |    |    |    |    |
|               | Generic List Block Length                                                                                          |   |   |   |   |   |   |   |   |   |    |    |    |    |    |    |    |    |    |    |    |    |    |    |    |    |    |    |    |    |    |    |
|               | Fix List Data Blocks*                                                                                              |   |   |   |   |   |   |   |   |   |    |    |    |    |    |    |    |    |    |    |    |    |    |    |    |    |    |    |    |    |    |    |

The following table describes the components of the User Product data block.

**Table B-15** User Product Data Block Fields for 4.10.x, 5.0-5.0.x

| Field                                | Data Type | Description                                                                                                                                                                                                         |
|--------------------------------------|-----------|---------------------------------------------------------------------------------------------------------------------------------------------------------------------------------------------------------------------|
| User Product Data Block Type         | uint32    | Initiates a User Product data block. This value is 65 for version 4.10.x and 118 for version 5.0 - 5.0.x.                                                                                                           |
| User Product Block Length            | uint32    | Total number of bytes in the User Product data block, including eight bytes for the user product block type and length fields, plus the number of bytes in the user product data that follows.                      |
| Source ID                            | uint32    | Identification number of the source that imported the data.                                                                                                                                                         |
| Source Type                          | uint32    | The source type of the source that supplied the data.                                                                                                                                                               |
| Generic List Block Type              | uint32    | Initiates a Generic List data block comprising IP Range Specification data blocks conveying IP address range data. This value is always 31.                                                                         |
| Generic List Block Length            | uint32    | Number of bytes in the Generic List data block, including the list header and all encapsulated IP Range Specification data blocks.                                                                                  |
| IP Range Specification Data Blocks * | variable  | IP Range Specification data blocks containing information about the IP address ranges for the user input. See <a href="#">IP Address Range Data Block for 5.2+, page 4-88</a> for a description of this data block. |
| Port                                 | uint16    | Port specified by the user.                                                                                                                                                                                         |
| Protocol                             | uint16    | IANA protocol number specified by the user. For example: <ul style="list-style-type: none"> <li>• 1 - ICMP</li> <li>• 4 - IP</li> <li>• 6 - TCP</li> <li>• 17 - UDP</li> </ul>                                      |
| Drop User Product                    | uint32    | Indicates whether the user OS definition was deleted from the host: <ul style="list-style-type: none"> <li>• 0 - No</li> <li>• 1 - Yes</li> </ul>                                                                   |

Table B-15 User Product Data Block Fields for 4.10.x, 5.0-5.0.x (continued)

| Field               | Data Type | Description                                                                                                                                                                                                      |
|---------------------|-----------|------------------------------------------------------------------------------------------------------------------------------------------------------------------------------------------------------------------|
| String Block Type   | uint32    | Initiates a String data block containing the custom vendor name specified in the user input. This value is always 0.                                                                                             |
| String Block Length | uint32    | Number of bytes in the custom vendor String data block, including eight bytes for the block type and length fields, plus the number of bytes in the vendor name.                                                 |
| Custom Vendor Name  | string    | The custom vendor name specified in the user input.                                                                                                                                                              |
| String Block Type   | uint32    | Initiates a String data block containing the custom product name specified in the user input. This value is always 0.                                                                                            |
| String Block Length | uint32    | Number of bytes in the custom product String data block, including eight bytes for the block type and length fields, plus the number of bytes in the product name.                                               |
| Custom Product Name | string    | The custom product name specified in the user input.                                                                                                                                                             |
| String Block Type   | uint32    | Initiates a String data block containing the custom version specified in the user input. This value is always 0.                                                                                                 |
| String Block Length | uint32    | Number of bytes in the custom version String data block, including eight bytes for the block type and length fields, plus the number of bytes in the version.                                                    |
| Custom Version      | string    | The custom version specified in the user input.                                                                                                                                                                  |
| Software ID         | uint32    | The identifier for a specific revision of a server or operating system in the Cisco database.                                                                                                                    |
| Server ID           | uint32    | The Cisco application identifier for the application protocol on the host server specified in user input.                                                                                                        |
| Vendor ID           | uint32    | The identifier for the vendor of a third party operating system specified when the third party operating system is mapped to a Cisco 3D operating system definition.                                             |
| Product ID          | uint32    | The product identification string of a third party operating system string specified when the third party operating system string is mapped to a Cisco 3D operating system definition.                           |
| String Block Type   | uint32    | Initiates a String data block containing the major version number of the Cisco 3D operating system definition that a third party operating system string in the user input is mapped to. This value is always 0. |
| String Block Length | uint32    | Number of bytes in the major String data block, including eight bytes for the block type and length fields, plus the number of bytes in the version.                                                             |
| Major Version       | string    | Major version of the Cisco 3D operating system definition that a third party operating system string is mapped to.                                                                                               |
| String Block Type   | uint32    | Initiates a String data block containing the minor version number of the Cisco 3D operating system definition that a third party operating system string is mapped to. This value is always 0.                   |

Table B-15 User Product Data Block Fields for 4.10.x, 5.0-5.0.x (continued)

| Field               | Data Type | Description                                                                                                                                                                                              |
|---------------------|-----------|----------------------------------------------------------------------------------------------------------------------------------------------------------------------------------------------------------|
| String Block Length | uint32    | Number of bytes in the minor String data block, including eight bytes for the block type and length fields, plus the number of bytes in the version.                                                     |
| Minor Version       | string    | Minor version number of the Cisco 3D operating system definition that a third party operating system string in the user input is mapped to.                                                              |
| String Block Type   | uint32    | Initiates a String data block containing the revision number of the Cisco operating system definition that a third party operating system string in the user input is mapped to. This value is always 0. |
| String Block Length | uint32    | Number of bytes in the revision String data block, including eight bytes for the block type and length fields, plus the number of bytes in the revision number.                                          |
| Revision            | string    | Revision number of the Cisco 3D operating system definition that a third party operating system string in the user input is mapped to.                                                                   |
| String Block Type   | uint32    | Initiates a String data block containing the last major version of the Cisco 3D operating system definition that a third party operating system string is mapped to. This value is always 0.             |
| String Block Length | uint32    | Number of bytes in the To Major String data block, including eight bytes for the block type and length fields, plus the number of bytes in the version.                                                  |
| To Major            | string    | Last version number in a range of major version numbers of the Cisco 3D operating system definition that a third party operating system string in the user input is mapped to.                           |
| String Block Type   | uint32    | Initiates a String data block containing the last minor version of the Cisco 3D operating system definition that a third party operating system string is mapped to. This value is always 0.             |
| String Block Length | uint32    | Number of bytes in the To Minor String data block, including eight bytes for the block type and length fields, plus the number of bytes in the version.                                                  |
| To Minor            | string    | Last version number in a range of minor version numbers of the Cisco 3D operating system definition that a third party operating system string in the user input is mapped to.                           |
| String Block Type   | uint32    | Initiates a String data block containing the Last revision number of the Cisco 3D operating system definition that a third party operating system string is mapped to. This value is always 0.           |
| String Block Length | uint32    | Number of bytes in the To Revision String data block, including eight bytes for the block type and length fields, plus the number of bytes in the revision number.                                       |
| To Revision         | string    | Last revision number in a range of revision numbers of the Cisco 3D operating system definitions that a third party operating system string in the user input is mapped to.                              |
| String Block Type   | uint32    | Initiates a String data block containing the build number of the Cisco 3D operating system that the third party operating system string is mapped. This value is always 0.                               |

Table B-15 User Product Data Block Fields for 4.10.x, 5.0-5.0.x (continued)

| Field                     | Data Type   | Description                                                                                                                                                                                                |
|---------------------------|-------------|------------------------------------------------------------------------------------------------------------------------------------------------------------------------------------------------------------|
| String Block Length       | uint32      | Number of bytes in the build String data block, including eight bytes for the block type and length fields, plus the number of bytes in the build number.                                                  |
| Build                     | string      | Build number of the Cisco 3D operating system that the third party operating system string in the user input is mapped to.                                                                                 |
| String Block Type         | uint32      | Initiates a String data block containing the patch number of the Cisco 3D operating system that the third party operating system string is mapped to. This value is always 0.                              |
| String Block Length       | uint32      | Number of bytes in the patch String data block, including eight bytes for the block type and length fields, plus the number of bytes in the patch number.                                                  |
| Patch                     | string      | Patch number of the Cisco 3D operating system that the third party operating system string in the user input is mapped to.                                                                                 |
| String Block Type         | uint32      | Initiates a String data block containing the extension number of the Cisco 3D operating system that the third party operating system string is mapped. This value is always 0.                             |
| String Block Length       | uint32      | Number of bytes in the extension String data block, including eight bytes for the block type and length fields, plus the number of bytes in the extension number.                                          |
| Extension                 | string      | Extension number of the Cisco 3D operating system that the third party operating system string in the user input is mapped to.                                                                             |
| UUID                      | uint8 [x16] | Contains the unique identification number for the operating system.                                                                                                                                        |
| Generic List Block Type   | uint32      | Initiates a Generic List data block comprising Fix List data blocks conveying user input data regarding what fixes have been applied to hosts in the specified IP address ranges. This value is always 31. |
| Generic List Block Length | uint32      | Number of bytes in the Generic List data block, including the list header and all encapsulated Fix List data blocks.                                                                                       |
| Fix List Data Blocks *    | variable    | Fix List data blocks containing information about fixes applied to the hosts. See <a href="#">Fix List Data Block, page 4-95</a> for a description of this data block.                                     |

## Legacy User Login Data Blocks

See the following section for more information:

- [User Login Information Data Block for 5.0 - 5.0.2, page B-68](#)

### User Login Information Data Block for 5.0 - 5.0.2

The User Login Information data block is used in User Information Update messages and conveys changes in login information for a detected user. For more information, see [User Information Update Message Block, page 4-55](#).

The User Login Information data block has a block type of 121 for version 5.0 - 5.0.2.

The graphic below shows the format of the User Login Information data block:

|           |                                         |   |   |   |   |   |   |   |   |   |    |    |    |    |    |    |    |    |    |    |    |    |    |    |    |    |    |    |    |    |    |    |
|-----------|-----------------------------------------|---|---|---|---|---|---|---|---|---|----|----|----|----|----|----|----|----|----|----|----|----|----|----|----|----|----|----|----|----|----|----|
| Byte      | 0                                       |   |   |   |   |   |   |   | 1 |   |    |    |    |    |    |    | 2  |    |    |    |    |    |    |    | 3  |    |    |    |    |    |    |    |
| Bit       | 0                                       | 1 | 2 | 3 | 4 | 5 | 6 | 7 | 8 | 9 | 10 | 11 | 12 | 13 | 14 | 15 | 16 | 17 | 18 | 19 | 20 | 21 | 22 | 23 | 24 | 25 | 26 | 27 | 28 | 29 | 30 | 31 |
|           | User Login Information Block Type (121) |   |   |   |   |   |   |   |   |   |    |    |    |    |    |    |    |    |    |    |    |    |    |    |    |    |    |    |    |    |    |    |
|           | User Login Information Block Length     |   |   |   |   |   |   |   |   |   |    |    |    |    |    |    |    |    |    |    |    |    |    |    |    |    |    |    |    |    |    |    |
|           | Timestamp                               |   |   |   |   |   |   |   |   |   |    |    |    |    |    |    |    |    |    |    |    |    |    |    |    |    |    |    |    |    |    |    |
|           | IP Address                              |   |   |   |   |   |   |   |   |   |    |    |    |    |    |    |    |    |    |    |    |    |    |    |    |    |    |    |    |    |    |    |
| User Name | String Block Type (0)                   |   |   |   |   |   |   |   |   |   |    |    |    |    |    |    |    |    |    |    |    |    |    |    |    |    |    |    |    |    |    |    |
|           | String Block Length                     |   |   |   |   |   |   |   |   |   |    |    |    |    |    |    |    |    |    |    |    |    |    |    |    |    |    |    |    |    |    |    |
|           | User Name...                            |   |   |   |   |   |   |   |   |   |    |    |    |    |    |    |    |    |    |    |    |    |    |    |    |    |    |    |    |    |    |    |
|           | User ID                                 |   |   |   |   |   |   |   |   |   |    |    |    |    |    |    |    |    |    |    |    |    |    |    |    |    |    |    |    |    |    |    |
|           | Application ID                          |   |   |   |   |   |   |   |   |   |    |    |    |    |    |    |    |    |    |    |    |    |    |    |    |    |    |    |    |    |    |    |
| Email     | String Block Type (0)                   |   |   |   |   |   |   |   |   |   |    |    |    |    |    |    |    |    |    |    |    |    |    |    |    |    |    |    |    |    |    |    |
|           | String Block Length                     |   |   |   |   |   |   |   |   |   |    |    |    |    |    |    |    |    |    |    |    |    |    |    |    |    |    |    |    |    |    |    |
|           | Email...                                |   |   |   |   |   |   |   |   |   |    |    |    |    |    |    |    |    |    |    |    |    |    |    |    |    |    |    |    |    |    |    |

The following table describes the components of the User Login Information data block.

**Table B-16** User Login Information Data Block Fields 5.0 - 5.0.2

| Field                               | Data Type | Description                                                                                                                                                                                                                  |
|-------------------------------------|-----------|------------------------------------------------------------------------------------------------------------------------------------------------------------------------------------------------------------------------------|
| User Login Information Block Type   | uint32    | Initiates a User Login Information data block. This value is 121 for version 5.0 - 5.0.2.                                                                                                                                    |
| User Login Information Block Length | uint32    | Total number of bytes in the User Login Information data block, including eight bytes for the user login information block type and length fields, plus the number of bytes in the user login information data that follows. |
| Timestamp                           | uint32    | Timestamp of the event.                                                                                                                                                                                                      |
| IP Address                          | uint8[4]  | IP address from the host where the user was detected logging in, in IP address octets.                                                                                                                                       |
| String Block Type                   | uint32    | Initiates a String data block containing the username for the user. This value is always 0.                                                                                                                                  |
| String Block Length                 | uint32    | Number of bytes in the username String data block, including eight bytes for the block type and length fields, plus the number of bytes in the username.                                                                     |

**Table B-16** User Login Information Data Block Fields 5.0 - 5.0.2 (continued)

| Field               | Data Type | Description                                                                                                                                                        |
|---------------------|-----------|--------------------------------------------------------------------------------------------------------------------------------------------------------------------|
| Username            | string    | The user name for the user.                                                                                                                                        |
| User ID             | uint32    | Identification number of the user.                                                                                                                                 |
| Application ID      | uint32    | The application ID for the application protocol used in the connection that the login information was derived from.                                                |
| String Block Type   | uint32    | Initiates a String data block containing the email address for the user. This value is always 0.                                                                   |
| String Block Length | uint32    | Number of bytes in the email address String data block, including eight bytes for the block type and length fields, plus the number of bytes in the email address. |
| Email               | string    | The email address for the user.                                                                                                                                    |

## Legacy Host Profile Data Blocks

See the following section for more information:

- [Host Profile Data Block for 5.0 - 5.0.2, page B-70](#)

### Host Profile Data Block for 5.0 - 5.0.2

The following diagram shows the format of a Host Profile data block in versions 5.0 to 5.0.2. The Host Profile data block also does not include a host criticality value, but does include a VLAN presence indicator. In addition, a Host Profile data block can convey a NetBIOS name for the host. This Host Profile data block has a block type of 91.



**Note**

An asterisk(\*) next to a block type field in the following diagram indicates the message may contain zero or more instances of the series 1 data block.

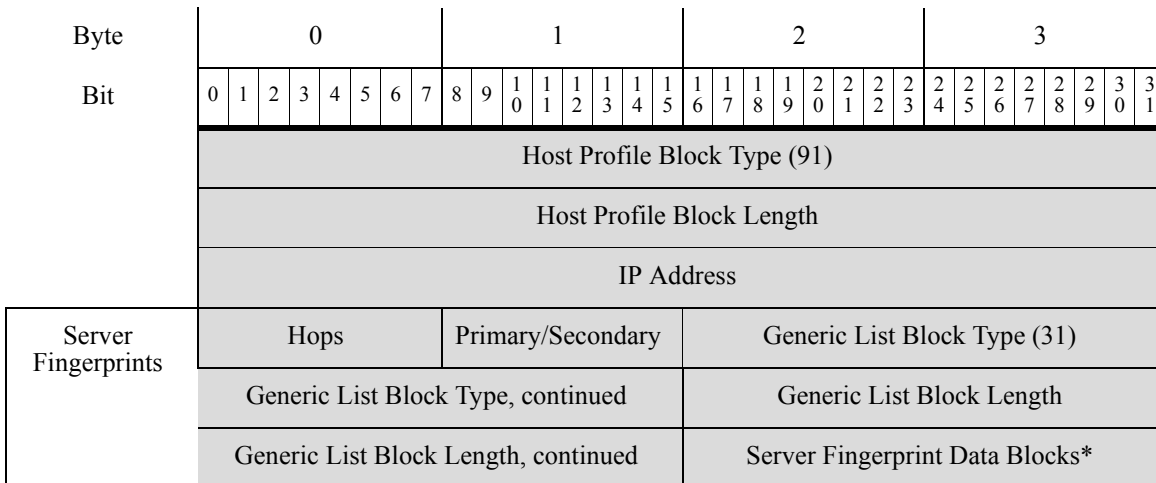

| Byte                     | 0                               |   |   |   |   |   |   |   | 1 |   |    |                           |    |    |    |    | 2  |    |    |    |    |    |    |    | 3  |    |    |    |    |    |    |    |
|--------------------------|---------------------------------|---|---|---|---|---|---|---|---|---|----|---------------------------|----|----|----|----|----|----|----|----|----|----|----|----|----|----|----|----|----|----|----|----|
|                          | 0                               | 1 | 2 | 3 | 4 | 5 | 6 | 7 | 8 | 9 | 10 | 11                        | 12 | 13 | 14 | 15 | 16 | 17 | 18 | 19 | 20 | 21 | 22 | 23 | 24 | 25 | 26 | 27 | 28 | 29 | 30 | 31 |
| Client Fingerprints      | Generic List Block Type (31)    |   |   |   |   |   |   |   |   |   |    |                           |    |    |    |    |    |    |    |    |    |    |    |    |    |    |    |    |    |    |    |    |
|                          | Generic List Block Length       |   |   |   |   |   |   |   |   |   |    |                           |    |    |    |    |    |    |    |    |    |    |    |    |    |    |    |    |    |    |    |    |
|                          | Client Fingerprint Data Blocks* |   |   |   |   |   |   |   |   |   |    |                           |    |    |    |    |    |    |    |    |    |    |    |    |    |    |    |    |    |    |    |    |
| SMB Fingerprints         | Generic List Block Type (31)    |   |   |   |   |   |   |   |   |   |    |                           |    |    |    |    |    |    |    |    |    |    |    |    |    |    |    |    |    |    |    |    |
|                          | Generic List Block Length       |   |   |   |   |   |   |   |   |   |    |                           |    |    |    |    |    |    |    |    |    |    |    |    |    |    |    |    |    |    |    |    |
|                          | SMB Fingerprint Data Blocks*    |   |   |   |   |   |   |   |   |   |    |                           |    |    |    |    |    |    |    |    |    |    |    |    |    |    |    |    |    |    |    |    |
| DHCP Fingerprints        | Generic List Block Type (31)    |   |   |   |   |   |   |   |   |   |    |                           |    |    |    |    |    |    |    |    |    |    |    |    |    |    |    |    |    |    |    |    |
|                          | Generic List Block Length       |   |   |   |   |   |   |   |   |   |    |                           |    |    |    |    |    |    |    |    |    |    |    |    |    |    |    |    |    |    |    |    |
|                          | DHCP Fingerprint Data Blocks*   |   |   |   |   |   |   |   |   |   |    |                           |    |    |    |    |    |    |    |    |    |    |    |    |    |    |    |    |    |    |    |    |
| TCP Server Block*        | List Block Type (11)            |   |   |   |   |   |   |   |   |   |    | List of TCP Servers       |    |    |    |    |    |    |    |    |    |    |    |    |    |    |    |    |    |    |    |    |
|                          | List Block Length               |   |   |   |   |   |   |   |   |   |    |                           |    |    |    |    |    |    |    |    |    |    |    |    |    |    |    |    |    |    |    |    |
|                          | Server Block Type (36)          |   |   |   |   |   |   |   |   |   |    |                           |    |    |    |    |    |    |    |    |    |    |    |    |    |    |    |    |    |    |    |    |
| TCP Server Block*        | Server Block Length             |   |   |   |   |   |   |   |   |   |    |                           |    |    |    |    |    |    |    |    |    |    |    |    |    |    |    |    |    |    |    |    |
|                          | TCP Server Data...              |   |   |   |   |   |   |   |   |   |    |                           |    |    |    |    |    |    |    |    |    |    |    |    |    |    |    |    |    |    |    |    |
|                          | List Block Type (11)            |   |   |   |   |   |   |   |   |   |    | List of UDP Servers       |    |    |    |    |    |    |    |    |    |    |    |    |    |    |    |    |    |    |    |    |
| List Block Length        |                                 |   |   |   |   |   |   |   |   |   |    |                           |    |    |    |    |    |    |    |    |    |    |    |    |    |    |    |    |    |    |    |    |
| Server Block Type (36)*  |                                 |   |   |   |   |   |   |   |   |   |    |                           |    |    |    |    |    |    |    |    |    |    |    |    |    |    |    |    |    |    |    |    |
| UDP Server Block*        | Server Block Length             |   |   |   |   |   |   |   |   |   |    |                           |    |    |    |    |    |    |    |    |    |    |    |    |    |    |    |    |    |    |    |    |
|                          | UDP Server Data...              |   |   |   |   |   |   |   |   |   |    |                           |    |    |    |    |    |    |    |    |    |    |    |    |    |    |    |    |    |    |    |    |
|                          | List Block Type (11)            |   |   |   |   |   |   |   |   |   |    | List of Network Protocols |    |    |    |    |    |    |    |    |    |    |    |    |    |    |    |    |    |    |    |    |
| List Block Length        |                                 |   |   |   |   |   |   |   |   |   |    |                           |    |    |    |    |    |    |    |    |    |    |    |    |    |    |    |    |    |    |    |    |
| Protocol Block Type (4)* |                                 |   |   |   |   |   |   |   |   |   |    |                           |    |    |    |    |    |    |    |    |    |    |    |    |    |    |    |    |    |    |    |    |
| Network Protocol Block*  | Protocol Block Length           |   |   |   |   |   |   |   |   |   |    |                           |    |    |    |    |    |    |    |    |    |    |    |    |    |    |    |    |    |    |    |    |
|                          | Network Protocol Data...        |   |   |   |   |   |   |   |   |   |    |                           |    |    |    |    |    |    |    |    |    |    |    |    |    |    |    |    |    |    |    |    |

| Byte                                 | 0                                      |   |   |   |   |   |   |                                      | 1                               |   |    |    |    |    |    |    | 2  |    |    |    |    |    |    |           | 3  |    |    |    |    |    |                             |                             |  |
|--------------------------------------|----------------------------------------|---|---|---|---|---|---|--------------------------------------|---------------------------------|---|----|----|----|----|----|----|----|----|----|----|----|----|----|-----------|----|----|----|----|----|----|-----------------------------|-----------------------------|--|
| Bit                                  | 0                                      | 1 | 2 | 3 | 4 | 5 | 6 | 7                                    | 8                               | 9 | 10 | 11 | 12 | 13 | 14 | 15 | 16 | 17 | 18 | 19 | 20 | 21 | 22 | 23        | 24 | 25 | 26 | 27 | 28 | 29 | 30                          | 31                          |  |
|                                      | List Block Type (11)                   |   |   |   |   |   |   |                                      |                                 |   |    |    |    |    |    |    |    |    |    |    |    |    |    |           |    |    |    |    |    |    |                             | List of Transport Protocols |  |
|                                      | List Block Length                      |   |   |   |   |   |   |                                      |                                 |   |    |    |    |    |    |    |    |    |    |    |    |    |    |           |    |    |    |    |    |    |                             |                             |  |
|                                      | Protocol Block Type (4)*               |   |   |   |   |   |   |                                      |                                 |   |    |    |    |    |    |    |    |    |    |    |    |    |    |           |    |    |    |    |    |    |                             |                             |  |
| Transport Protocol Block*            | Protocol Block Length                  |   |   |   |   |   |   |                                      |                                 |   |    |    |    |    |    |    |    |    |    |    |    |    |    |           |    |    |    |    |    |    |                             |                             |  |
|                                      | Transport Protocol Data...             |   |   |   |   |   |   |                                      |                                 |   |    |    |    |    |    |    |    |    |    |    |    |    |    |           |    |    |    |    |    |    |                             |                             |  |
|                                      | List Block Type (11)                   |   |   |   |   |   |   |                                      |                                 |   |    |    |    |    |    |    |    |    |    |    |    |    |    |           |    |    |    |    |    |    |                             | List of MAC Addresses       |  |
| List Block Length                    |                                        |   |   |   |   |   |   |                                      |                                 |   |    |    |    |    |    |    |    |    |    |    |    |    |    |           |    |    |    |    |    |    |                             |                             |  |
| MAC Address Block Type (95)*         |                                        |   |   |   |   |   |   |                                      |                                 |   |    |    |    |    |    |    |    |    |    |    |    |    |    |           |    |    |    |    |    |    |                             |                             |  |
| MAC Address Block*                   | MAC Address Block Length               |   |   |   |   |   |   |                                      |                                 |   |    |    |    |    |    |    |    |    |    |    |    |    |    |           |    |    |    |    |    |    |                             |                             |  |
|                                      | MAC Address Data...                    |   |   |   |   |   |   |                                      |                                 |   |    |    |    |    |    |    |    |    |    |    |    |    |    |           |    |    |    |    |    |    |                             |                             |  |
|                                      | Host Last Seen                         |   |   |   |   |   |   |                                      |                                 |   |    |    |    |    |    |    |    |    |    |    |    |    |    |           |    |    |    |    |    |    |                             |                             |  |
| Host Type                            |                                        |   |   |   |   |   |   |                                      |                                 |   |    |    |    |    |    |    |    |    |    |    |    |    |    |           |    |    |    |    |    |    |                             |                             |  |
| VLAN Presence                        |                                        |   |   |   |   |   |   | VLAN ID                              |                                 |   |    |    |    |    |    |    |    |    |    |    |    |    |    | VLAN Type |    |    |    |    |    |    |                             |                             |  |
| VLAN Priority                        |                                        |   |   |   |   |   |   | Generic List Block Type (31)         |                                 |   |    |    |    |    |    |    |    |    |    |    |    |    |    |           |    |    |    |    |    |    | List of Client Applications |                             |  |
| Generic List Block Type, continued   |                                        |   |   |   |   |   |   | Generic List Block Length            |                                 |   |    |    |    |    |    |    |    |    |    |    |    |    |    |           |    |    |    |    |    |    |                             |                             |  |
| Generic List Block Length, continued |                                        |   |   |   |   |   |   | Client Application Block Type (112)* |                                 |   |    |    |    |    |    |    |    |    |    |    |    |    |    |           |    |    |    |    |    |    |                             |                             |  |
| Client App Data                      | Client App Block Type (29)*, con't     |   |   |   |   |   |   |                                      | Client Application Block Length |   |    |    |    |    |    |    |    |    |    |    |    |    |    |           |    |    |    |    |    |    |                             |                             |  |
|                                      | Client Application Block Length, con't |   |   |   |   |   |   |                                      | Client Application Data...      |   |    |    |    |    |    |    |    |    |    |    |    |    |    |           |    |    |    |    |    |    |                             |                             |  |
|                                      | String Block Type (0)                  |   |   |   |   |   |   |                                      |                                 |   |    |    |    |    |    |    |    |    |    |    |    |    |    |           |    |    |    |    |    |    |                             |                             |  |
| NetBIOS Name                         | String Block Length                    |   |   |   |   |   |   |                                      |                                 |   |    |    |    |    |    |    |    |    |    |    |    |    |    |           |    |    |    |    |    |    |                             |                             |  |
|                                      | NetBIOS String Data...                 |   |   |   |   |   |   |                                      |                                 |   |    |    |    |    |    |    |    |    |    |    |    |    |    |           |    |    |    |    |    |    |                             |                             |  |



The following table describes the fields of the host profile data block returned by version 4.9 to version 5.0.2.

**Table B-17** *Host Profile Data Block for 5.0 - 5.0.2 Fields*

| Field                                                           | Data Type | Description                                                                                                                                                                                                                                                              |
|-----------------------------------------------------------------|-----------|--------------------------------------------------------------------------------------------------------------------------------------------------------------------------------------------------------------------------------------------------------------------------|
| Host Profile Block Type                                         | uint32    | Initiates the Host Profile data block for 4.9 to 5.0.2. This data block has a block type of 91.                                                                                                                                                                          |
| Host Profile Block Length                                       | uint32    | Number of bytes in the Host Profile data block, including eight bytes for the host profile block type and length fields, plus the number of bytes included in the host profile data that follows.                                                                        |
| IP Address                                                      | uint8[4]  | IP address of the host described in the profile, in IP address octets.                                                                                                                                                                                                   |
| Hops                                                            | uint8     | Number of hops from the host to the device.                                                                                                                                                                                                                              |
| Primary/Secondary                                               | uint8     | Indicates whether the host is in the primary or secondary network of the device that detected it: <ul style="list-style-type: none"> <li>0 - host is in the primary network.</li> <li>1 - host is in the secondary network.</li> </ul>                                   |
| Generic List Block Type                                         | uint32    | Initiates a Generic List data block comprising Operating System Fingerprint data blocks conveying fingerprint data identified using a server fingerprint. This value is always 31.                                                                                       |
| Generic List Block Length                                       | uint32    | Number of bytes in the Generic List data block, including the list header and all encapsulated Operating System Fingerprint data blocks.                                                                                                                                 |
| Operating System Fingerprint (Server Fingerprint) Data Blocks * | variable  | Operating System Fingerprint data blocks containing information about the operating system on a host identified using a server fingerprint. See <a href="#">Operating System Fingerprint Data Block for 5.0 - 5.0.2, page B-77</a> for a description of this data block. |
| Generic List Block Type                                         | uint32    | Initiates a Generic List data block comprising Operating System Fingerprint data blocks conveying fingerprint data identified using a client fingerprint. This value is always 31.                                                                                       |
| Generic List Block Length                                       | uint32    | Number of bytes in the Generic List data block, including the list header and all encapsulated Operating System Fingerprint data blocks.                                                                                                                                 |
| Operating System Fingerprint (Client Fingerprint) Data Blocks * | variable  | Operating System Fingerprint data blocks containing information about the operating system on a host identified using a client fingerprint. See <a href="#">Operating System Fingerprint Data Block for 5.0 - 5.0.2, page B-77</a> for a description of this data block. |
| Generic List Block Type                                         | uint32    | Initiates a Generic List data block comprising Operating System Fingerprint data blocks conveying fingerprint data identified using an SMB fingerprint. This value is always 31.                                                                                         |
| Generic List Block Length                                       | uint32    | Number of bytes in the Generic List data block, including the list header and all encapsulated Operating System Fingerprint data blocks.                                                                                                                                 |

Table B-17 Host Profile Data Block for 5.0 - 5.0.2 Fields (continued)

| Field                                                         | Data Type | Description                                                                                                                                                                                                                                                            |
|---------------------------------------------------------------|-----------|------------------------------------------------------------------------------------------------------------------------------------------------------------------------------------------------------------------------------------------------------------------------|
| Operating System Fingerprint (SMB Fingerprint) Data Blocks *  | variable  | Operating System Fingerprint data blocks containing information about the operating system on a host identified using an SMB fingerprint. See <a href="#">Operating System Fingerprint Data Block for 5.0 - 5.0.2, page B-77</a> for a description of this data block. |
| Generic List Block Type                                       | uint32    | Initiates a Generic List data block comprising Operating System Fingerprint data blocks conveying fingerprint data identified using a DHCP fingerprint. This value is always 31.                                                                                       |
| Generic List Block Length                                     | uint32    | Number of bytes in the Generic List data block, including the list header and all encapsulated Operating System Fingerprint data blocks.                                                                                                                               |
| Operating System Fingerprint (DHCP Fingerprint) Data Blocks * | variable  | Operating System Fingerprint data blocks containing information about the operating system on a host identified using a DHCP fingerprint. See <a href="#">Operating System Fingerprint Data Block for 5.0 - 5.0.2, page B-77</a> for a description of this data block. |
| List Block Type                                               | uint32    | Initiates a List data block comprising Server data blocks conveying TCP server data. This value is always 11.                                                                                                                                                          |
| List Block Length                                             | uint32    | Number of bytes in the list. This number includes the eight bytes of the list block type and length fields, plus all encapsulated Server data blocks.<br><br>This field is followed by zero or more Server data blocks.                                                |
| Server Block Type                                             | uint32    | Initiates a Server data block. This value is always 89.                                                                                                                                                                                                                |
| Server Block Length                                           | uint32    | Number of bytes in the Server data block, including eight bytes for the server block type and length fields, plus the number of bytes of TCP server data that follows.                                                                                                 |
| TCP Server Data                                               | variable  | Data fields describing a TCP server (as documented for earlier versions of the product).                                                                                                                                                                               |
| List Block Type                                               | uint32    | Initiates a List data block comprising Server data blocks conveying UDP server data. This value is always 11.                                                                                                                                                          |
| List Block Length                                             | uint32    | Number of bytes in the list. This number includes the eight bytes of the list block type and length fields, plus all encapsulated Server data blocks.<br><br>This field is followed by zero or more Server data blocks.                                                |
| Server Block Type                                             | uint32    | Initiates a Server data block describing a UDP server. This value is always 89.                                                                                                                                                                                        |
| Server Block Length                                           | uint32    | Number of bytes in the Server data block, including eight bytes for the server block type and length fields, plus the number of bytes of UDP server data that follows.                                                                                                 |
| UDP Server Data                                               | variable  | Data fields describing a UDP server (as documented for earlier versions of the product).                                                                                                                                                                               |

Table B-17 Host Profile Data Block for 5.0 - 5.0.2 Fields (continued)

| Field                         | Data Type | Description                                                                                                                                                                                                                           |
|-------------------------------|-----------|---------------------------------------------------------------------------------------------------------------------------------------------------------------------------------------------------------------------------------------|
| List Block Type               | uint32    | Initiates a List data block comprising Protocol data blocks conveying network protocol data. This value is always 11.                                                                                                                 |
| List Block Length             | uint32    | Number of bytes in the list. This number includes the eight bytes of the list block type and length fields, plus all encapsulated Protocol data blocks.<br><br>This field is followed by zero or more Protocol data blocks.           |
| Protocol Block Type           | uint32    | Initiates a Protocol data block describing a network protocol. This value is always 4.                                                                                                                                                |
| Protocol Block Length         | uint32    | Number of bytes in the Protocol data block, including eight bytes for the protocol block type and length fields, plus the number of bytes in the protocol data that follows.                                                          |
| Network Protocol Data         | uint16    | Data field containing a network protocol number, as documented in <a href="#">Protocol Data Block, page 4-68</a> .                                                                                                                    |
| List Block Type               | uint32    | Initiates a List data block comprising Protocol data blocks conveying transport protocol data. This value is always 11.                                                                                                               |
| List Block Length             | uint32    | Number of bytes in the list. This number includes the eight bytes of the list block type and length fields, plus all encapsulated Protocol data blocks.<br><br>This field is followed by zero or more transport protocol data blocks. |
| Protocol Block Type           | uint32    | Initiates a Protocol data block describing a transport protocol. This value is always 4.                                                                                                                                              |
| Protocol Block Length         | uint32    | Number of bytes in the protocol data block, including eight bytes for the protocol block type and length, plus the number of bytes in the protocol data that follows.                                                                 |
| Transport Protocol Data       | variable  | Data field containing a transport protocol number, as documented in <a href="#">Protocol Data Block, page 4-68</a> .                                                                                                                  |
| List Block Type               | uint32    | Initiates a List data block comprising MAC Address data blocks. This value is always 11.                                                                                                                                              |
| List Block Length             | uint32    | Number of bytes in the list, including the list header and all encapsulated MAC Address data blocks.                                                                                                                                  |
| Host MAC Address Block Type   | uint32    | Initiates a Host MAC Address data block. This value is always 95.                                                                                                                                                                     |
| Host MAC Address Block Length | uint32    | Number of bytes in the Host MAC Address data block, including eight bytes for the Host MAC address block type and length fields, plus the number of bytes in the Host MAC address data that follows.                                  |
| Host MAC Address Data         | variable  | Host MAC address data fields described in <a href="#">Host MAC Address 4.9+, page 4-108</a> .                                                                                                                                         |
| Host Last Seen                | uint32    | UNIX timestamp that represents the last time the system detected host activity.                                                                                                                                                       |

Table B-17 Host Profile Data Block for 5.0 - 5.0.2 Fields (continued)

| Field                           | Data Type | Description                                                                                                                                                                                                                    |
|---------------------------------|-----------|--------------------------------------------------------------------------------------------------------------------------------------------------------------------------------------------------------------------------------|
| Host Type                       | uint32    | Indicates the host type. The following values may appear: <ul style="list-style-type: none"> <li>• 0 - host</li> <li>• 1 - router</li> <li>• 2 - bridge</li> <li>• 3 - NAT device</li> <li>• 4 - LB (load balancer)</li> </ul> |
| VLAN Presence                   | uint8     | Indicates whether a VLAN is present: <ul style="list-style-type: none"> <li>• 0 - Yes</li> <li>• 1 - No</li> </ul>                                                                                                             |
| VLAN ID                         | uint16    | VLAN identification number that indicates which VLAN the host is a member of.                                                                                                                                                  |
| VLAN Type                       | uint8     | Type of packet encapsulated in the VLAN tag.                                                                                                                                                                                   |
| VLAN Priority                   | uint8     | Priority value included in the VLAN tag.                                                                                                                                                                                       |
| Generic List Block Type         | uint32    | Initiates a Generic List data block comprising Client Application data blocks conveying client application data. This value is always 31.                                                                                      |
| Generic List Block Length       | uint32    | Number of bytes in the Generic List data block, including the list header and all encapsulated client application data blocks.                                                                                                 |
| Client Application Block Type   | uint32    | Initiates a client application block. This value is always 5.                                                                                                                                                                  |
| Client Application Block Length | uint32    | Number of bytes in the client application block, including eight bytes for the client application block type and length fields, plus the number of bytes in the client application data that follows.                          |
| Client Application Data         | variable  | Client application data fields describing a client application, as documented in <a href="#">Host Client Application Data Block for 5.0+</a> , page 4-137.                                                                     |
| String Block Type               | uint32    | Initiates a string data block for the NetBIOS name. This value is set to 0 to indicate string data.                                                                                                                            |
| String Block Length             | uint32    | Indicates the number of bytes in the NetBIOS name data block, including eight bytes for the string block type and length, plus the number of bytes in the NetBIOS name.                                                        |
| NetBIOS String Data             | Variable  | Contains the NetBIOS name of the host described in the host profile.                                                                                                                                                           |

# Legacy OS Fingerprint Data Blocks

See the following section for more information:

- [Operating System Fingerprint Data Block for 5.0 - 5.0.2, page B-77](#)

## Operating System Fingerprint Data Block for 5.0 - 5.0.2

The Operating System Fingerprint data block has a block type of 87. The block includes a fingerprint Universally Unique Identifier (UUID), as well as the fingerprint type, the fingerprint source type, and the fingerprint source ID. The following diagram shows the format of an Operating System Fingerprint data block for version 5.0 to version 5.0.2.

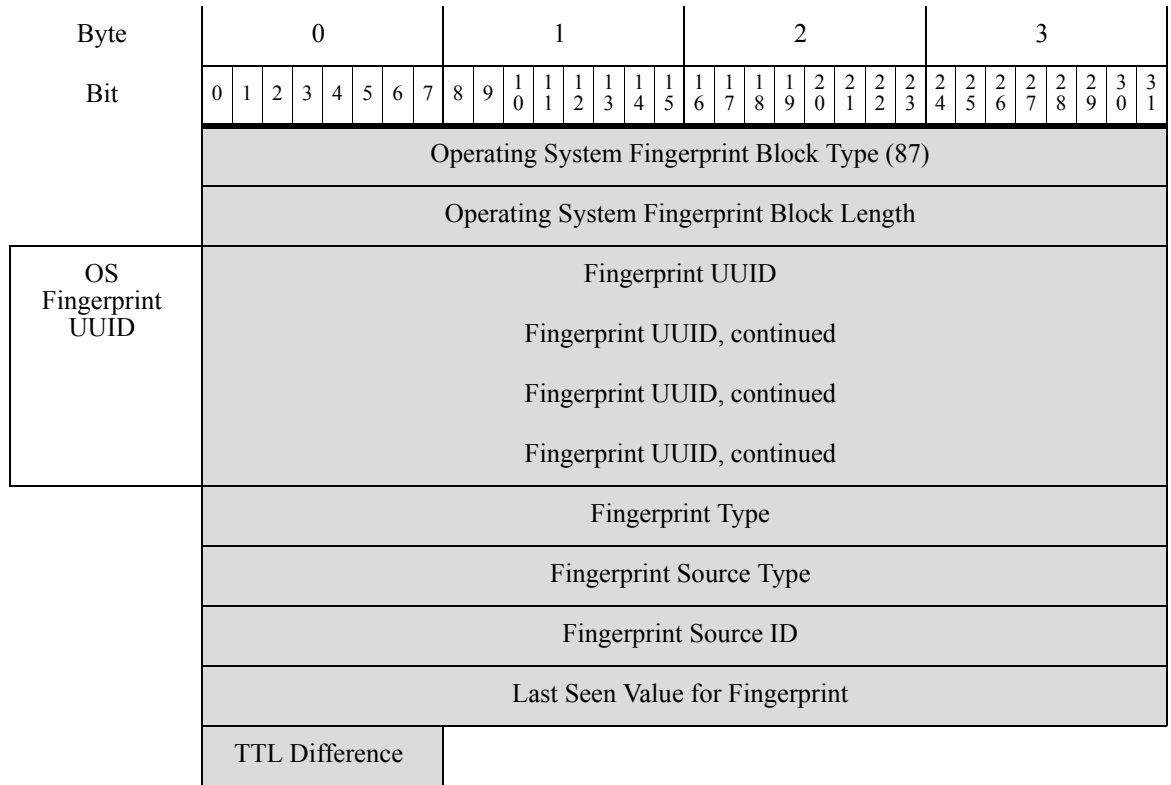

The following table describes the fields of the operating system fingerprint data block.

**Table B-18** *Operating System Fingerprint Data Block Fields*

| Field                                        | Data Type | Description                                                                                                                                                                                                                                                                                                                                                                                              |
|----------------------------------------------|-----------|----------------------------------------------------------------------------------------------------------------------------------------------------------------------------------------------------------------------------------------------------------------------------------------------------------------------------------------------------------------------------------------------------------|
| Operating System Fingerprint Data Block Type | uint32    | Initiates the operating system data block. This value is always 87.                                                                                                                                                                                                                                                                                                                                      |
| Operating System Data Block Length           | uint32    | Number of bytes in the Operating System Fingerprint data block. This value should always be 41: eight bytes for the data block type and length fields, sixteen bytes for the fingerprint UUID value, four bytes for the fingerprint type, four bytes for the fingerprint source type, four bytes for the fingerprint source ID, four bytes for the last seen value, and one byte for the TTL difference. |
| Fingerprint UUID                             | uint8[16] | Fingerprint identification number, in octets, that acts as a unique identifier for the operating system. The fingerprint UUID maps to the operating system name, vendor, and version in the vulnerability database (VDB).                                                                                                                                                                                |
| Fingerprint Type                             | uint32    | Indicates the type of fingerprint.                                                                                                                                                                                                                                                                                                                                                                       |
| Fingerprint Source Type                      | uint32    | Indicates the type (i.e., user or scanner) of the source that supplied the operating system fingerprint.                                                                                                                                                                                                                                                                                                 |
| Fingerprint Source ID                        | uint32    | Indicates the ID of the source that supplied the operating system fingerprint.                                                                                                                                                                                                                                                                                                                           |
| Last Seen                                    | uint32    | Indicates when the fingerprint was last seen in traffic.                                                                                                                                                                                                                                                                                                                                                 |
| TTL Difference                               | uint8     | Indicates the difference between the TTL value in the fingerprint and the TTL value seen in the packet used to fingerprint the host.                                                                                                                                                                                                                                                                     |

## Legacy Connection Data Structures

For more information, see the following sections:

- [Connection Statistics Data Block 5.0 - 5.0.2, page B-78](#)
- [Connection Statistics Data Block 5.1, page B-83](#)
- [Connection Statistics Data Block 5.2.x, page B-89](#)
- [Connection Chunk Data Block for 5.0 - 5.1, page B-95](#)
- [Connection Statistics Data Block 5.1.1.x, page B-96](#)
- [Connection Statistics Data Block 5.3, page B-102](#)

### Connection Statistics Data Block 5.0 - 5.0.2

The Connection Statistics data block is used in Connection Data messages. The Connection Statistics data block for version 5.0 - 5.0.2 has a block type of 115.

For more information on the Connection Statistics Data message, see [Connection Statistics Data Message, page 4-46](#).

The following diagram shows the format of a Connection Statistics data block for 5.0 - 5.0.2:

::

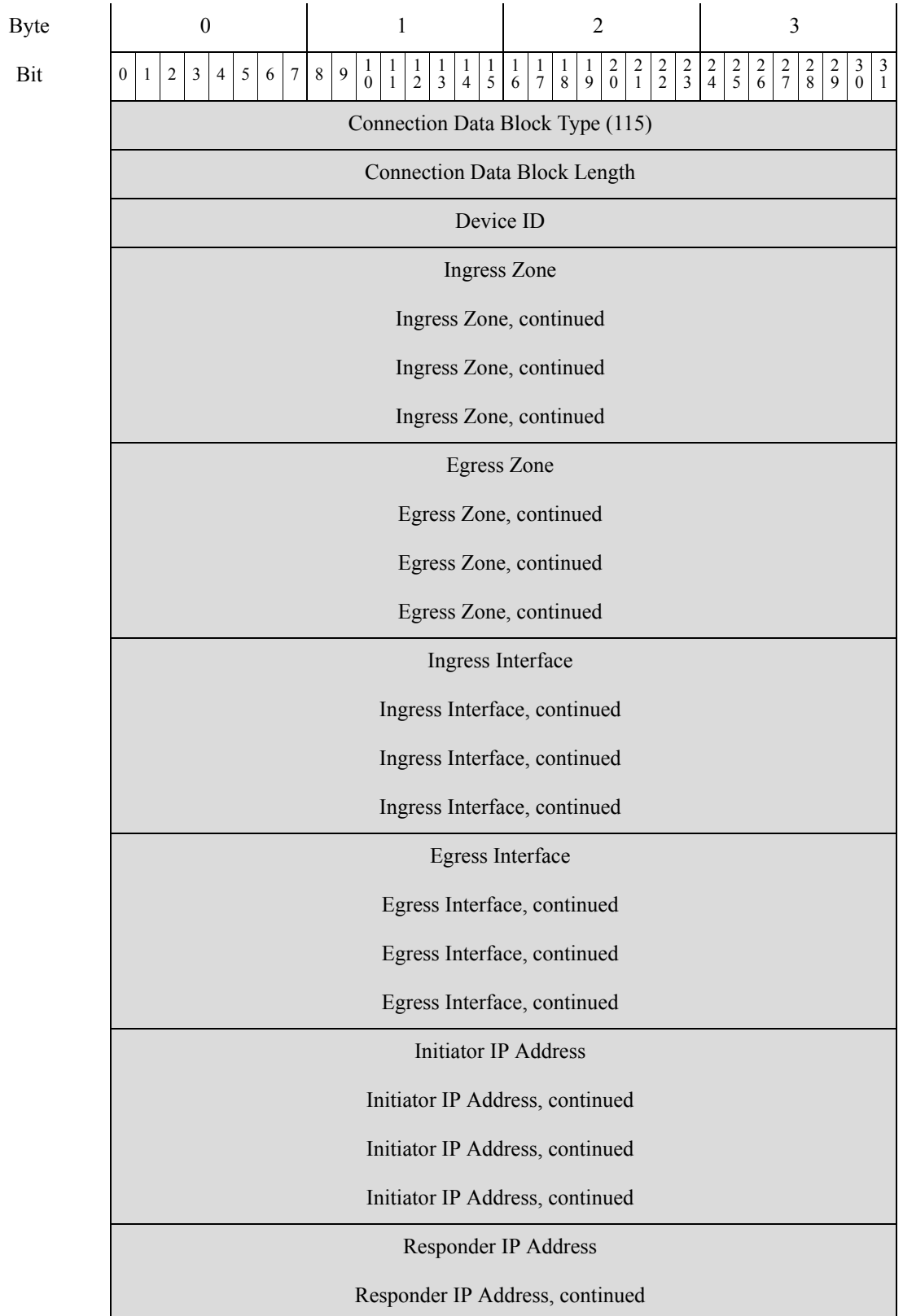

|      |                                   |   |   |   |   |   |   |   |   |   |    |    |    |    |    |    |                |    |    |    |    |    |    |    |                         |    |    |    |    |    |    |    |
|------|-----------------------------------|---|---|---|---|---|---|---|---|---|----|----|----|----|----|----|----------------|----|----|----|----|----|----|----|-------------------------|----|----|----|----|----|----|----|
| Byte | 0                                 |   |   |   |   |   |   |   | 1 |   |    |    |    |    |    |    | 2              |    |    |    |    |    |    |    | 3                       |    |    |    |    |    |    |    |
| Bit  | 0                                 | 1 | 2 | 3 | 4 | 5 | 6 | 7 | 8 | 9 | 10 | 11 | 12 | 13 | 14 | 15 | 16             | 17 | 18 | 19 | 20 | 21 | 22 | 23 | 24                      | 25 | 26 | 27 | 28 | 29 | 30 | 31 |
|      | Responder IP Address, continued   |   |   |   |   |   |   |   |   |   |    |    |    |    |    |    |                |    |    |    |    |    |    |    |                         |    |    |    |    |    |    |    |
|      | Responder IP Address, continued   |   |   |   |   |   |   |   |   |   |    |    |    |    |    |    |                |    |    |    |    |    |    |    |                         |    |    |    |    |    |    |    |
|      | Policy Revision                   |   |   |   |   |   |   |   |   |   |    |    |    |    |    |    |                |    |    |    |    |    |    |    |                         |    |    |    |    |    |    |    |
|      | Policy Revision, continued        |   |   |   |   |   |   |   |   |   |    |    |    |    |    |    |                |    |    |    |    |    |    |    |                         |    |    |    |    |    |    |    |
|      | Policy Revision, continued        |   |   |   |   |   |   |   |   |   |    |    |    |    |    |    |                |    |    |    |    |    |    |    |                         |    |    |    |    |    |    |    |
|      | Policy Revision, continued        |   |   |   |   |   |   |   |   |   |    |    |    |    |    |    |                |    |    |    |    |    |    |    |                         |    |    |    |    |    |    |    |
|      | Rule ID                           |   |   |   |   |   |   |   |   |   |    |    |    |    |    |    |                |    |    |    |    |    |    |    |                         |    |    |    |    |    |    |    |
|      | Rule Action                       |   |   |   |   |   |   |   |   |   |    |    |    |    |    |    |                |    |    |    |    |    |    |    |                         |    |    |    |    |    |    |    |
|      | Initiator Port                    |   |   |   |   |   |   |   |   |   |    |    |    |    |    |    | Responder Port |    |    |    |    |    |    |    |                         |    |    |    |    |    |    |    |
|      | TCP Flags                         |   |   |   |   |   |   |   |   |   |    |    |    |    |    |    | Protocol       |    |    |    |    |    |    |    | NetFlow Source          |    |    |    |    |    |    |    |
|      | NetFlow Source, continued         |   |   |   |   |   |   |   |   |   |    |    |    |    |    |    |                |    |    |    |    |    |    |    |                         |    |    |    |    |    |    |    |
|      | NetFlow Source, continued         |   |   |   |   |   |   |   |   |   |    |    |    |    |    |    |                |    |    |    |    |    |    |    |                         |    |    |    |    |    |    |    |
|      | NetFlow Source, continued         |   |   |   |   |   |   |   |   |   |    |    |    |    |    |    |                |    |    |    |    |    |    |    |                         |    |    |    |    |    |    |    |
|      | NetFlow Source, continued         |   |   |   |   |   |   |   |   |   |    |    |    |    |    |    |                |    |    |    |    |    |    |    | First Pkt Time          |    |    |    |    |    |    |    |
|      | First Packet Timestamp, continued |   |   |   |   |   |   |   |   |   |    |    |    |    |    |    |                |    |    |    |    |    |    |    | Last Pkt Time           |    |    |    |    |    |    |    |
|      | Last Packet Timestamp, continued  |   |   |   |   |   |   |   |   |   |    |    |    |    |    |    |                |    |    |    |    |    |    |    | Packets Sent            |    |    |    |    |    |    |    |
|      | Packets Sent, continued           |   |   |   |   |   |   |   |   |   |    |    |    |    |    |    |                |    |    |    |    |    |    |    |                         |    |    |    |    |    |    |    |
|      | Packets Sent, continued           |   |   |   |   |   |   |   |   |   |    |    |    |    |    |    |                |    |    |    |    |    |    |    | Packets Rcvd            |    |    |    |    |    |    |    |
|      | Packets Received, continued       |   |   |   |   |   |   |   |   |   |    |    |    |    |    |    |                |    |    |    |    |    |    |    |                         |    |    |    |    |    |    |    |
|      | Packets Received, continued       |   |   |   |   |   |   |   |   |   |    |    |    |    |    |    |                |    |    |    |    |    |    |    | Bytes Sent              |    |    |    |    |    |    |    |
|      | Bytes Sent, continued             |   |   |   |   |   |   |   |   |   |    |    |    |    |    |    |                |    |    |    |    |    |    |    |                         |    |    |    |    |    |    |    |
|      | Packets Received, continued       |   |   |   |   |   |   |   |   |   |    |    |    |    |    |    |                |    |    |    |    |    |    |    | Bytes Rcvd              |    |    |    |    |    |    |    |
|      | Bytes Received, continued         |   |   |   |   |   |   |   |   |   |    |    |    |    |    |    |                |    |    |    |    |    |    |    |                         |    |    |    |    |    |    |    |
|      | Bytes Received, continued         |   |   |   |   |   |   |   |   |   |    |    |    |    |    |    |                |    |    |    |    |    |    |    | User ID                 |    |    |    |    |    |    |    |
|      | User ID, continued                |   |   |   |   |   |   |   |   |   |    |    |    |    |    |    |                |    |    |    |    |    |    |    | Application Protocol ID |    |    |    |    |    |    |    |



| Byte               | 0                                  |   |   |   |   |   |   |   | 1 |   |    |    |    |    |    |    | 2                         |    |    |    |    |    |    |    | 3  |    |    |    |    |    |    |    |
|--------------------|------------------------------------|---|---|---|---|---|---|---|---|---|----|----|----|----|----|----|---------------------------|----|----|----|----|----|----|----|----|----|----|----|----|----|----|----|
| Bit                | 0                                  | 1 | 2 | 3 | 4 | 5 | 6 | 7 | 8 | 9 | 10 | 11 | 12 | 13 | 14 | 15 | 16                        | 17 | 18 | 19 | 20 | 21 | 22 | 23 | 24 | 25 | 26 | 27 | 28 | 29 | 30 | 31 |
|                    | Application Protocol ID, continued |   |   |   |   |   |   |   |   |   |    |    |    |    |    |    | URL Category              |    |    |    |    |    |    |    |    |    |    |    |    |    |    |    |
|                    | URL Category, continued            |   |   |   |   |   |   |   |   |   |    |    |    |    |    |    | URL Reputation            |    |    |    |    |    |    |    |    |    |    |    |    |    |    |    |
|                    | URL Reputation, continued          |   |   |   |   |   |   |   |   |   |    |    |    |    |    |    | Client App ID             |    |    |    |    |    |    |    |    |    |    |    |    |    |    |    |
|                    | Client Application ID, continued   |   |   |   |   |   |   |   |   |   |    |    |    |    |    |    | Web App ID                |    |    |    |    |    |    |    |    |    |    |    |    |    |    |    |
|                    | Web Application ID, continued      |   |   |   |   |   |   |   |   |   |    |    |    |    |    |    | String Block Type (0)     |    |    |    |    |    |    |    |    |    |    |    |    |    |    |    |
| Client App URL     | String Block Type, continued       |   |   |   |   |   |   |   |   |   |    |    |    |    |    |    | String Block Length       |    |    |    |    |    |    |    |    |    |    |    |    |    |    |    |
|                    | String Block Length, continued     |   |   |   |   |   |   |   |   |   |    |    |    |    |    |    | Client Application URL... |    |    |    |    |    |    |    |    |    |    |    |    |    |    |    |
| NetBIOS Name       | String Block Type (0)              |   |   |   |   |   |   |   |   |   |    |    |    |    |    |    |                           |    |    |    |    |    |    |    |    |    |    |    |    |    |    |    |
|                    | String Block Length                |   |   |   |   |   |   |   |   |   |    |    |    |    |    |    |                           |    |    |    |    |    |    |    |    |    |    |    |    |    |    |    |
|                    | NetBIOS Name....                   |   |   |   |   |   |   |   |   |   |    |    |    |    |    |    |                           |    |    |    |    |    |    |    |    |    |    |    |    |    |    |    |
| Client App Version | String Block Type (0)              |   |   |   |   |   |   |   |   |   |    |    |    |    |    |    |                           |    |    |    |    |    |    |    |    |    |    |    |    |    |    |    |
|                    | String Block Length                |   |   |   |   |   |   |   |   |   |    |    |    |    |    |    |                           |    |    |    |    |    |    |    |    |    |    |    |    |    |    |    |
|                    | Client Application Version...      |   |   |   |   |   |   |   |   |   |    |    |    |    |    |    |                           |    |    |    |    |    |    |    |    |    |    |    |    |    |    |    |

The following table describes the fields of the Connection Statistics data block for 5.0 - 5.0.2.

**Table B-19** Connection Statistics Data Block 5.0 - 5.0.2 Fields

| Field                                   | Data Type | Description                                                                                                                                                                                              |
|-----------------------------------------|-----------|----------------------------------------------------------------------------------------------------------------------------------------------------------------------------------------------------------|
| Connection Statistics Data Block Type   | uint32    | Initiates a Connection Statistics data block for 5.0 to 5.0.2. The value is always 115.                                                                                                                  |
| Connection Statistics Data Block Length | uint32    | Number of bytes in the Connection Statistics data block, including eight bytes for the connection statistics block type and length fields, plus the number of bytes in the connection data that follows. |
| Device ID                               | uint32    | The device that detected the connection event.                                                                                                                                                           |
| Ingress Zone                            | uint8[16] | Ingress security zone in the event that triggered the policy violation.                                                                                                                                  |
| Egress Zone                             | uint8[16] | Egress security zone in the event that triggered the policy violation.                                                                                                                                   |
| Ingress Interface                       | uint8[16] | Interface for the inbound traffic.                                                                                                                                                                       |
| Egress Interface                        | uint8[16] | Interface for the outbound traffic.                                                                                                                                                                      |

Table B-19 Connection Statistics Data Block 5.0 - 5.0.2 Fields (continued)

| Field                   | Data Type | Description                                                                                                                                                                                        |
|-------------------------|-----------|----------------------------------------------------------------------------------------------------------------------------------------------------------------------------------------------------|
| Initiator IP Address    | uint8[16] | IP address of the host that initiated the session described in the connection event, in IP address octets.                                                                                         |
| Responder IP Address    | uint8[16] | IP address of the host that responded to the initiating host, in IP address octets.                                                                                                                |
| Policy Revision         | uint8[16] | Revision number of the rule associated with the triggered correlation event, if applicable.                                                                                                        |
| Rule ID                 | uint32    | Internal identifier for the rule that triggered the event, if applicable.                                                                                                                          |
| Rule Action             | uint32    | The action selected in the user interface for that rule (allow, block, and so forth).                                                                                                              |
| Initiator Port          | uint16    | Port used by the initiating host.                                                                                                                                                                  |
| Responder Port          | uint16    | Port used by the responding host.                                                                                                                                                                  |
| TCP Flags               | uint16    | Indicates any TCP flags for the connection event.                                                                                                                                                  |
| Protocol                | uint8     | The IANA-specified protocol number.                                                                                                                                                                |
| NetFlow Source          | uint8[16] | IP address of the NetFlow-enabled device that exported the data for the connection                                                                                                                 |
| First Packet Timestamp  | uint32    | UNIX timestamp of the date and time the first packet was exchanged in the session.                                                                                                                 |
| Last Packet Timestamp   | uint32    | UNIX timestamp of the date and time the last packet was exchanged in the session.                                                                                                                  |
| Packets Sent            | uint64    | Number of packets transmitted by the initiating host.                                                                                                                                              |
| Packets Received        | uint64    | Number of packets transmitted by the responding host.                                                                                                                                              |
| Bytes Sent              | uint64    | Number of bytes transmitted by the initiating host.                                                                                                                                                |
| Bytes Received          | uint64    | Number of bytes transmitted by the responding host.                                                                                                                                                |
| User ID                 | uint32    | Internal identification number for the user who last logged into the host that generated the traffic.                                                                                              |
| Application Protocol ID | uint32    | Application ID of the application protocol.                                                                                                                                                        |
| URL Category            | uint32    | The internal identification number of the URL category.                                                                                                                                            |
| URL Reputation          | uint32    | The internal identification number for the URL reputation.                                                                                                                                         |
| Client Application ID   | uint32    | The internal identification number of the detected client application, if applicable.                                                                                                              |
| Web Application ID      | uint32    | The internal identification number of the detected web application, if applicable.                                                                                                                 |
| String Block Type       | uint32    | Initiates a String data block for the client application URL. This value is always 0.                                                                                                              |
| String Block Length     | uint32    | Number of bytes in the client application URL String data block, including eight bytes for the string block type and length fields, plus the number of bytes in the client application URL string. |

Table B-19 Connection Statistics Data Block 5.0 - 5.0.2 Fields (continued)

| Field                      | Data Type | Description                                                                                                                                                                       |
|----------------------------|-----------|-----------------------------------------------------------------------------------------------------------------------------------------------------------------------------------|
| Client Application URL     | string    | URL the client application accessed, if applicable (/files/index.html, for example).                                                                                              |
| String Block Type          | uint32    | Initiates a String data block for the host NetBIOS name. This value is always 0.                                                                                                  |
| String Block Length        | uint32    | Number of bytes in the String data block, including eight bytes for the string block type and length fields, plus the number of bytes in the NetBIOS name string.                 |
| NetBIOS Name               | string    | Host NetBIOS name string.                                                                                                                                                         |
| String Block Type          | uint32    | Initiates a String data block for the client application version. This value is always 0.                                                                                         |
| String Block Length        | uint32    | Number of bytes in the String data block for the client application version, including eight bytes for the string block type and length, plus the number of bytes in the version. |
| Client Application Version | string    | Client application version.                                                                                                                                                       |

## Connection Statistics Data Block 5.1

The Connection Statistics data block is used in Connection Data messages. Changes to the Connection data block between 5.0.2 and 5.1 include the addition of new fields with configuration parameters introduced in 5.1 (rule action reason, monitor rules, Security Intelligence source/destination, Security Intelligence layer). The Connection Statistics data block for version 5.1 has a block type of 126.

For more information on the Connection Statistics Data message, see [Connection Statistics Data Message, page 4-46](#).

The following diagram shows the format of a Connection Statistics data block for 5.1:

::

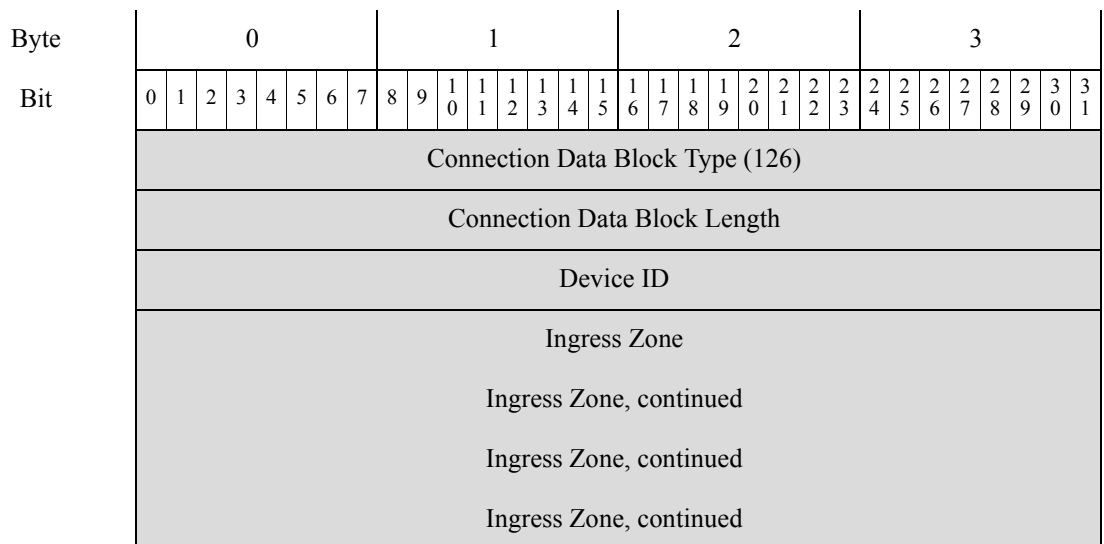

| Byte                            | 0 |   |   |   |   |   |   |   | 1 |   |    |    |    |    |    |             | 2  |    |    |    |    |    |    |    | 3  |    |    |    |    |    |    |    |
|---------------------------------|---|---|---|---|---|---|---|---|---|---|----|----|----|----|----|-------------|----|----|----|----|----|----|----|----|----|----|----|----|----|----|----|----|
| Bit                             | 0 | 1 | 2 | 3 | 4 | 5 | 6 | 7 | 8 | 9 | 10 | 11 | 12 | 13 | 14 | 15          | 16 | 17 | 18 | 19 | 20 | 21 | 22 | 23 | 24 | 25 | 26 | 27 | 28 | 29 | 30 | 31 |
| Egress Zone                     |   |   |   |   |   |   |   |   |   |   |    |    |    |    |    |             |    |    |    |    |    |    |    |    |    |    |    |    |    |    |    |    |
| Egress Zone, continued          |   |   |   |   |   |   |   |   |   |   |    |    |    |    |    |             |    |    |    |    |    |    |    |    |    |    |    |    |    |    |    |    |
| Egress Zone, continued          |   |   |   |   |   |   |   |   |   |   |    |    |    |    |    |             |    |    |    |    |    |    |    |    |    |    |    |    |    |    |    |    |
| Egress Zone, continued          |   |   |   |   |   |   |   |   |   |   |    |    |    |    |    |             |    |    |    |    |    |    |    |    |    |    |    |    |    |    |    |    |
| Ingress Interface               |   |   |   |   |   |   |   |   |   |   |    |    |    |    |    |             |    |    |    |    |    |    |    |    |    |    |    |    |    |    |    |    |
| Ingress Interface, continued    |   |   |   |   |   |   |   |   |   |   |    |    |    |    |    |             |    |    |    |    |    |    |    |    |    |    |    |    |    |    |    |    |
| Ingress Interface, continued    |   |   |   |   |   |   |   |   |   |   |    |    |    |    |    |             |    |    |    |    |    |    |    |    |    |    |    |    |    |    |    |    |
| Ingress Interface, continued    |   |   |   |   |   |   |   |   |   |   |    |    |    |    |    |             |    |    |    |    |    |    |    |    |    |    |    |    |    |    |    |    |
| Egress Interface                |   |   |   |   |   |   |   |   |   |   |    |    |    |    |    |             |    |    |    |    |    |    |    |    |    |    |    |    |    |    |    |    |
| Egress Interface, continued     |   |   |   |   |   |   |   |   |   |   |    |    |    |    |    |             |    |    |    |    |    |    |    |    |    |    |    |    |    |    |    |    |
| Egress Interface, continued     |   |   |   |   |   |   |   |   |   |   |    |    |    |    |    |             |    |    |    |    |    |    |    |    |    |    |    |    |    |    |    |    |
| Egress Interface, continued     |   |   |   |   |   |   |   |   |   |   |    |    |    |    |    |             |    |    |    |    |    |    |    |    |    |    |    |    |    |    |    |    |
| Initiator IP Address            |   |   |   |   |   |   |   |   |   |   |    |    |    |    |    |             |    |    |    |    |    |    |    |    |    |    |    |    |    |    |    |    |
| Initiator IP Address, continued |   |   |   |   |   |   |   |   |   |   |    |    |    |    |    |             |    |    |    |    |    |    |    |    |    |    |    |    |    |    |    |    |
| Initiator IP Address, continued |   |   |   |   |   |   |   |   |   |   |    |    |    |    |    |             |    |    |    |    |    |    |    |    |    |    |    |    |    |    |    |    |
| Initiator IP Address, continued |   |   |   |   |   |   |   |   |   |   |    |    |    |    |    |             |    |    |    |    |    |    |    |    |    |    |    |    |    |    |    |    |
| Responder IP Address            |   |   |   |   |   |   |   |   |   |   |    |    |    |    |    |             |    |    |    |    |    |    |    |    |    |    |    |    |    |    |    |    |
| Responder IP Address, continued |   |   |   |   |   |   |   |   |   |   |    |    |    |    |    |             |    |    |    |    |    |    |    |    |    |    |    |    |    |    |    |    |
| Responder IP Address, continued |   |   |   |   |   |   |   |   |   |   |    |    |    |    |    |             |    |    |    |    |    |    |    |    |    |    |    |    |    |    |    |    |
| Responder IP Address, continued |   |   |   |   |   |   |   |   |   |   |    |    |    |    |    |             |    |    |    |    |    |    |    |    |    |    |    |    |    |    |    |    |
| Policy Revision                 |   |   |   |   |   |   |   |   |   |   |    |    |    |    |    |             |    |    |    |    |    |    |    |    |    |    |    |    |    |    |    |    |
| Policy Revision, continued      |   |   |   |   |   |   |   |   |   |   |    |    |    |    |    |             |    |    |    |    |    |    |    |    |    |    |    |    |    |    |    |    |
| Policy Revision, continued      |   |   |   |   |   |   |   |   |   |   |    |    |    |    |    |             |    |    |    |    |    |    |    |    |    |    |    |    |    |    |    |    |
| Policy Revision, continued      |   |   |   |   |   |   |   |   |   |   |    |    |    |    |    |             |    |    |    |    |    |    |    |    |    |    |    |    |    |    |    |    |
| Rule ID                         |   |   |   |   |   |   |   |   |   |   |    |    |    |    |    |             |    |    |    |    |    |    |    |    |    |    |    |    |    |    |    |    |
| Rule Action                     |   |   |   |   |   |   |   |   |   |   |    |    |    |    |    | Rule Reason |    |    |    |    |    |    |    |    |    |    |    |    |    |    |    |    |

| Byte | 0                                        |   |   |   |   |   |   |   | 1 |   |    |    |    |    |    |    | 2                             |    |    |    |    |    |    |    | 3                             |    |    |    |    |    |    |    |
|------|------------------------------------------|---|---|---|---|---|---|---|---|---|----|----|----|----|----|----|-------------------------------|----|----|----|----|----|----|----|-------------------------------|----|----|----|----|----|----|----|
| Bit  | 0                                        | 1 | 2 | 3 | 4 | 5 | 6 | 7 | 8 | 9 | 10 | 11 | 12 | 13 | 14 | 15 | 16                            | 17 | 18 | 19 | 20 | 21 | 22 | 23 | 24                            | 25 | 26 | 27 | 28 | 29 | 30 | 31 |
|      | Initiator Port                           |   |   |   |   |   |   |   |   |   |    |    |    |    |    |    | Responder Port                |    |    |    |    |    |    |    |                               |    |    |    |    |    |    |    |
|      | TCP Flags                                |   |   |   |   |   |   |   |   |   |    |    |    |    |    |    | Protocol                      |    |    |    |    |    |    |    | NetFlow Source                |    |    |    |    |    |    |    |
|      | NetFlow Source, continued                |   |   |   |   |   |   |   |   |   |    |    |    |    |    |    |                               |    |    |    |    |    |    |    |                               |    |    |    |    |    |    |    |
|      | NetFlow Source, continued                |   |   |   |   |   |   |   |   |   |    |    |    |    |    |    |                               |    |    |    |    |    |    |    |                               |    |    |    |    |    |    |    |
|      | NetFlow Source, continued                |   |   |   |   |   |   |   |   |   |    |    |    |    |    |    |                               |    |    |    |    |    |    |    |                               |    |    |    |    |    |    |    |
|      | NetFlow Source, continued                |   |   |   |   |   |   |   |   |   |    |    |    |    |    |    |                               |    |    |    |    |    |    |    | First Pkt Time                |    |    |    |    |    |    |    |
|      | First Packet Timestamp, continued        |   |   |   |   |   |   |   |   |   |    |    |    |    |    |    | Last Pkt Time                 |    |    |    |    |    |    |    |                               |    |    |    |    |    |    |    |
|      | Last Packet Timestamp, continued         |   |   |   |   |   |   |   |   |   |    |    |    |    |    |    | Initiator Transmitted Packets |    |    |    |    |    |    |    |                               |    |    |    |    |    |    |    |
|      | Initiator Transmitted Packets, continued |   |   |   |   |   |   |   |   |   |    |    |    |    |    |    |                               |    |    |    |    |    |    |    |                               |    |    |    |    |    |    |    |
|      | Initiator Transmitted Packets, continued |   |   |   |   |   |   |   |   |   |    |    |    |    |    |    |                               |    |    |    |    |    |    |    | Responder Transmitted Packets |    |    |    |    |    |    |    |
|      | Responder Transmitted Packets, continued |   |   |   |   |   |   |   |   |   |    |    |    |    |    |    |                               |    |    |    |    |    |    |    |                               |    |    |    |    |    |    |    |
|      | Responder Transmitted Packets, continued |   |   |   |   |   |   |   |   |   |    |    |    |    |    |    |                               |    |    |    |    |    |    |    | Initiator Transmitted Bytes   |    |    |    |    |    |    |    |
|      | Initiator Transmitted Bytes, continued   |   |   |   |   |   |   |   |   |   |    |    |    |    |    |    |                               |    |    |    |    |    |    |    |                               |    |    |    |    |    |    |    |
|      | Initiator Transmitted Bytes, continued   |   |   |   |   |   |   |   |   |   |    |    |    |    |    |    |                               |    |    |    |    |    |    |    | Responder Transmitted Bytes   |    |    |    |    |    |    |    |
|      | Responder Transmitted Bytes, continued   |   |   |   |   |   |   |   |   |   |    |    |    |    |    |    |                               |    |    |    |    |    |    |    |                               |    |    |    |    |    |    |    |
|      | Responder Transmitted Bytes, continued   |   |   |   |   |   |   |   |   |   |    |    |    |    |    |    |                               |    |    |    |    |    |    |    | User ID                       |    |    |    |    |    |    |    |
|      | User ID, continued                       |   |   |   |   |   |   |   |   |   |    |    |    |    |    |    | Application Protocol ID       |    |    |    |    |    |    |    |                               |    |    |    |    |    |    |    |
|      | Application Protocol ID, continued       |   |   |   |   |   |   |   |   |   |    |    |    |    |    |    | URL Category                  |    |    |    |    |    |    |    |                               |    |    |    |    |    |    |    |
|      | URL Category, continued                  |   |   |   |   |   |   |   |   |   |    |    |    |    |    |    | URL Reputation                |    |    |    |    |    |    |    |                               |    |    |    |    |    |    |    |
|      | URL Reputation, continued                |   |   |   |   |   |   |   |   |   |    |    |    |    |    |    | Client App ID                 |    |    |    |    |    |    |    |                               |    |    |    |    |    |    |    |
|      | Client Application ID, continued         |   |   |   |   |   |   |   |   |   |    |    |    |    |    |    | Web App ID                    |    |    |    |    |    |    |    |                               |    |    |    |    |    |    |    |
|      | Web Application ID, continued            |   |   |   |   |   |   |   |   |   |    |    |    |    |    |    | String Block Type (0)         |    |    |    |    |    |    |    |                               |    |    |    |    |    |    |    |

| Byte               | 0                              |   |   |   |   |   |   |   | 1 |   |    |    |    |    |    |                     | 2  |    |    |    |    |    |    |    | 3                         |    |    |    |    |    |    |    |
|--------------------|--------------------------------|---|---|---|---|---|---|---|---|---|----|----|----|----|----|---------------------|----|----|----|----|----|----|----|----|---------------------------|----|----|----|----|----|----|----|
|                    | 0                              | 1 | 2 | 3 | 4 | 5 | 6 | 7 | 8 | 9 | 10 | 11 | 12 | 13 | 14 | 15                  | 16 | 17 | 18 | 19 | 20 | 21 | 22 | 23 | 24                        | 25 | 26 | 27 | 28 | 29 | 30 | 31 |
| Client App URL     | String Block Type, continued   |   |   |   |   |   |   |   |   |   |    |    |    |    |    |                     |    |    |    |    |    |    |    |    | String Block Length       |    |    |    |    |    |    |    |
|                    | String Block Length, continued |   |   |   |   |   |   |   |   |   |    |    |    |    |    |                     |    |    |    |    |    |    |    |    | Client Application URL... |    |    |    |    |    |    |    |
| NetBIOS Name       | String Block Type (0)          |   |   |   |   |   |   |   |   |   |    |    |    |    |    |                     |    |    |    |    |    |    |    |    |                           |    |    |    |    |    |    |    |
|                    | String Block Length            |   |   |   |   |   |   |   |   |   |    |    |    |    |    |                     |    |    |    |    |    |    |    |    |                           |    |    |    |    |    |    |    |
|                    | NetBIOS Name....               |   |   |   |   |   |   |   |   |   |    |    |    |    |    |                     |    |    |    |    |    |    |    |    |                           |    |    |    |    |    |    |    |
| Client App Version | String Block Type (0)          |   |   |   |   |   |   |   |   |   |    |    |    |    |    |                     |    |    |    |    |    |    |    |    |                           |    |    |    |    |    |    |    |
|                    | String Block Length            |   |   |   |   |   |   |   |   |   |    |    |    |    |    |                     |    |    |    |    |    |    |    |    |                           |    |    |    |    |    |    |    |
|                    | Client Application Version...  |   |   |   |   |   |   |   |   |   |    |    |    |    |    |                     |    |    |    |    |    |    |    |    |                           |    |    |    |    |    |    |    |
| Monitor Rule 1     |                                |   |   |   |   |   |   |   |   |   |    |    |    |    |    |                     |    |    |    |    |    |    |    |    |                           |    |    |    |    |    |    |    |
| Monitor Rule 2     |                                |   |   |   |   |   |   |   |   |   |    |    |    |    |    |                     |    |    |    |    |    |    |    |    |                           |    |    |    |    |    |    |    |
| Monitor Rule 3     |                                |   |   |   |   |   |   |   |   |   |    |    |    |    |    |                     |    |    |    |    |    |    |    |    |                           |    |    |    |    |    |    |    |
| Monitor Rule 4     |                                |   |   |   |   |   |   |   |   |   |    |    |    |    |    |                     |    |    |    |    |    |    |    |    |                           |    |    |    |    |    |    |    |
| Monitor Rule 5     |                                |   |   |   |   |   |   |   |   |   |    |    |    |    |    |                     |    |    |    |    |    |    |    |    |                           |    |    |    |    |    |    |    |
| Monitor Rule 6     |                                |   |   |   |   |   |   |   |   |   |    |    |    |    |    |                     |    |    |    |    |    |    |    |    |                           |    |    |    |    |    |    |    |
| Monitor Rule 7     |                                |   |   |   |   |   |   |   |   |   |    |    |    |    |    |                     |    |    |    |    |    |    |    |    |                           |    |    |    |    |    |    |    |
| Monitor Rule 8     |                                |   |   |   |   |   |   |   |   |   |    |    |    |    |    |                     |    |    |    |    |    |    |    |    |                           |    |    |    |    |    |    |    |
| Sec. Int. Src/Dst  |                                |   |   |   |   |   |   |   |   |   |    |    |    |    |    | Sec. Int. Rep Layer |    |    |    |    |    |    |    |    |                           |    |    |    |    |    |    |    |

The following table describes the fields of the Connection Statistics data block for 5.1.

Table B-20 Connection Statistics Data Block 5.1 Fields

| Field                                   | Data Type | Description                                                                                                                                                                                              |
|-----------------------------------------|-----------|----------------------------------------------------------------------------------------------------------------------------------------------------------------------------------------------------------|
| Connection Statistics Data Block Type   | uint32    | Initiates a Connection Statistics data block for 5.1. The value is always 126.                                                                                                                           |
| Connection Statistics Data Block Length | uint32    | Number of bytes in the Connection Statistics data block, including eight bytes for the connection statistics block type and length fields, plus the number of bytes in the connection data that follows. |
| Device ID                               | uint32    | The device that detected the connection event.                                                                                                                                                           |
| Ingress Zone                            | uint8[16] | Ingress security zone in the event that triggered the policy violation.                                                                                                                                  |

Table B-20 Connection Statistics Data Block 5.1 Fields (continued)

| Field                         | Data Type | Description                                                                                                |
|-------------------------------|-----------|------------------------------------------------------------------------------------------------------------|
| Egress Zone                   | uint8[16] | Egress security zone in the event that triggered the policy violation.                                     |
| Ingress Interface             | uint8[16] | Interface for the inbound traffic.                                                                         |
| Egress Interface              | uint8[16] | Interface for the outbound traffic.                                                                        |
| Initiator IP Address          | uint8[16] | IP address of the host that initiated the session described in the connection event, in IP address octets. |
| Responder IP Address          | uint8[16] | IP address of the host that responded to the initiating host, in IP address octets.                        |
| Policy Revision               | uint8[16] | Revision number of the rule associated with the triggered correlation event, if applicable.                |
| Rule ID                       | uint32    | Internal identifier for the rule that triggered the event, if applicable.                                  |
| Rule Action                   | uint16    | The action selected in the user interface for that rule (allow, block, and so forth).                      |
| Rule Reason                   | uint16    | The reason the rule triggered the event.                                                                   |
| Initiator Port                | uint16    | Port used by the initiating host.                                                                          |
| Responder Port                | uint16    | Port used by the responding host.                                                                          |
| TCP Flags                     | uint16    | Indicates any TCP flags for the connection event.                                                          |
| Protocol                      | uint8     | The IANA-specified protocol number.                                                                        |
| NetFlow Source                | uint8[16] | IP address of the NetFlow-enabled device that exported the data for the connection.                        |
| First Packet Timestamp        | uint32    | UNIX timestamp of the date and time the first packet was exchanged in the session.                         |
| Last Packet Timestamp         | uint32    | UNIX timestamp of the date and time the last packet was exchanged in the session.                          |
| Initiator Transmitted Packets | uint64    | Number of packets transmitted by the initiating host.                                                      |
| Responder Transmitted Packets | uint64    | Number of packets transmitted by the responding host.                                                      |
| Initiator Transmitted Bytes   | uint64    | Number of bytes transmitted by the initiating host.                                                        |
| Responder Transmitted Bytes   | uint64    | Number of bytes transmitted by the responding host.                                                        |
| User ID                       | uint32    | Internal identification number for the user who last logged into the host that generated the traffic.      |
| Application Protocol ID       | uint32    | Application ID of the application protocol.                                                                |
| URL Category                  | uint32    | The internal identification number of the URL category.                                                    |
| URL Reputation                | uint32    | The internal identification number for the URL reputation.                                                 |

Table B-20 Connection Statistics Data Block 5.1 Fields (continued)

| Field                      | Data Type | Description                                                                                                                                                                                        |
|----------------------------|-----------|----------------------------------------------------------------------------------------------------------------------------------------------------------------------------------------------------|
| Client Application ID      | uint32    | The internal identification number of the detected client application, if applicable.                                                                                                              |
| Web Application ID         | uint32    | The internal identification number of the detected web application, if applicable.                                                                                                                 |
| String Block Type          | uint32    | Initiates a String data block for the client application URL. This value is always 0.                                                                                                              |
| String Block Length        | uint32    | Number of bytes in the client application URL String data block, including eight bytes for the string block type and length fields, plus the number of bytes in the client application URL string. |
| Client Application URL     | string    | URL the client application accessed, if applicable (/files/index.html, for example).                                                                                                               |
| String Block Type          | uint32    | Initiates a String data block for the host NetBIOS name. This value is always 0.                                                                                                                   |
| String Block Length        | uint32    | Number of bytes in the String data block, including eight bytes for the string block type and length fields, plus the number of bytes in the NetBIOS name string.                                  |
| NetBIOS Name               | string    | Host NetBIOS name string.                                                                                                                                                                          |
| String Block Type          | uint32    | Initiates a String data block for the client application version. This value is always 0.                                                                                                          |
| String Block Length        | uint32    | Number of bytes in the String data block for the client application version, including eight bytes for the string block type and length, plus the number of bytes in the version.                  |
| Client Application Version | string    | Client application version.                                                                                                                                                                        |
| Monitor Rule 1             | uint32    | The ID of the first monitor rule associated with the connection event.                                                                                                                             |
| Monitor Rule 2             | uint32    | The ID of the second monitor rule associated with the connection event.                                                                                                                            |
| Monitor Rule 3             | uint32    | The ID of the third monitor rule associated with the connection event.                                                                                                                             |
| Monitor Rule 4             | uint32    | The ID of the fourth monitor rule associated with the connection event.                                                                                                                            |
| Monitor Rule 5             | uint32    | The ID of the fifth monitor rule associated with the connection event.                                                                                                                             |
| Monitor Rule 6             | uint32    | The ID of the sixth monitor rule associated with the connection event.                                                                                                                             |
| Monitor Rule 7             | uint32    | The ID of the seventh monitor rule associated with the connection event.                                                                                                                           |
| Monitor Rule 8             | uint32    | The ID of the eighth monitor rule associated with the connection event.                                                                                                                            |



**Table B-20** Connection Statistics Data Block 5.1 Fields (continued)

| Field                                    | Data Type | Description                                                            |
|------------------------------------------|-----------|------------------------------------------------------------------------|
| Security Intelligence Source/Destination | uint8     | Whether the source or destination IP address matched the IP blacklist. |
| Security Intelligence Layer              | uint8     | The IP layer that matched the IP blacklist.                            |

## Connection Statistics Data Block 5.2.x

The connection statistics data block is used in connection data messages. Changes to the connection data block between versions 5.1.1 and 5.2 include the addition of new fields to support geolocation. The connection statistics data block for version 5.2.x has a block type of 144 in the series 1 group of blocks. It deprecates block type 137, [Connection Statistics Data Block 5.1.1.x](#), page B-96.

For more information on the Connection Statistics Data message, see [Connection Statistics Data Message](#), page 4-46.

The following diagram shows the format of a Connection Statistics data block for 5.2.x:

::

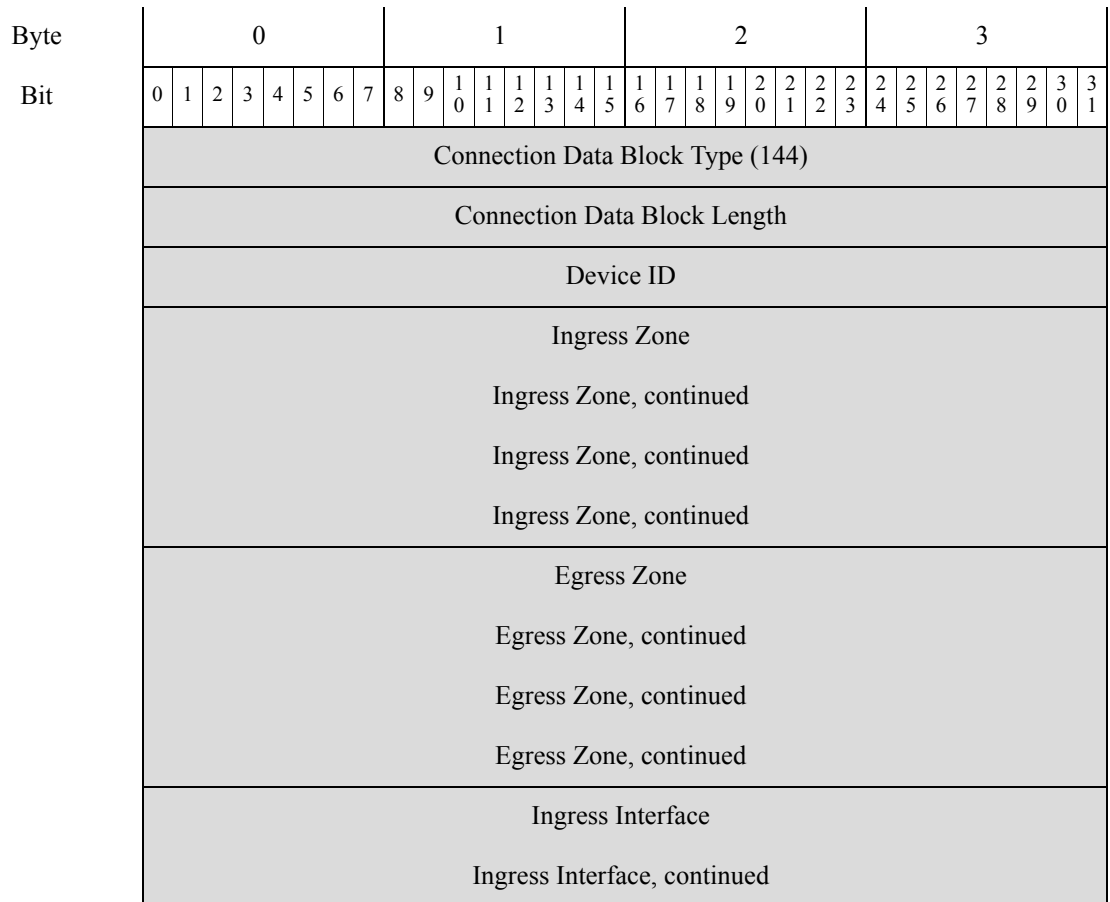

|      |                                 |   |   |   |   |   |   |   |   |   |    |    |    |    |    |    |                |    |    |    |    |    |    |    |                |    |    |    |    |    |    |    |
|------|---------------------------------|---|---|---|---|---|---|---|---|---|----|----|----|----|----|----|----------------|----|----|----|----|----|----|----|----------------|----|----|----|----|----|----|----|
| Byte | 0                               |   |   |   |   |   |   |   | 1 |   |    |    |    |    |    |    | 2              |    |    |    |    |    |    |    | 3              |    |    |    |    |    |    |    |
| Bit  | 0                               | 1 | 2 | 3 | 4 | 5 | 6 | 7 | 8 | 9 | 10 | 11 | 12 | 13 | 14 | 15 | 16             | 17 | 18 | 19 | 20 | 21 | 22 | 23 | 24             | 25 | 26 | 27 | 28 | 29 | 30 | 31 |
|      | Ingress Interface, continued    |   |   |   |   |   |   |   |   |   |    |    |    |    |    |    |                |    |    |    |    |    |    |    |                |    |    |    |    |    |    |    |
|      | Ingress Interface, continued    |   |   |   |   |   |   |   |   |   |    |    |    |    |    |    |                |    |    |    |    |    |    |    |                |    |    |    |    |    |    |    |
|      | Egress Interface                |   |   |   |   |   |   |   |   |   |    |    |    |    |    |    |                |    |    |    |    |    |    |    |                |    |    |    |    |    |    |    |
|      | Egress Interface, continued     |   |   |   |   |   |   |   |   |   |    |    |    |    |    |    |                |    |    |    |    |    |    |    |                |    |    |    |    |    |    |    |
|      | Egress Interface, continued     |   |   |   |   |   |   |   |   |   |    |    |    |    |    |    |                |    |    |    |    |    |    |    |                |    |    |    |    |    |    |    |
|      | Egress Interface, continued     |   |   |   |   |   |   |   |   |   |    |    |    |    |    |    |                |    |    |    |    |    |    |    |                |    |    |    |    |    |    |    |
|      | Initiator IP Address            |   |   |   |   |   |   |   |   |   |    |    |    |    |    |    |                |    |    |    |    |    |    |    |                |    |    |    |    |    |    |    |
|      | Initiator IP Address, continued |   |   |   |   |   |   |   |   |   |    |    |    |    |    |    |                |    |    |    |    |    |    |    |                |    |    |    |    |    |    |    |
|      | Initiator IP Address, continued |   |   |   |   |   |   |   |   |   |    |    |    |    |    |    |                |    |    |    |    |    |    |    |                |    |    |    |    |    |    |    |
|      | Initiator IP Address, continued |   |   |   |   |   |   |   |   |   |    |    |    |    |    |    |                |    |    |    |    |    |    |    |                |    |    |    |    |    |    |    |
|      | Responder IP Address            |   |   |   |   |   |   |   |   |   |    |    |    |    |    |    |                |    |    |    |    |    |    |    |                |    |    |    |    |    |    |    |
|      | Responder IP Address, continued |   |   |   |   |   |   |   |   |   |    |    |    |    |    |    |                |    |    |    |    |    |    |    |                |    |    |    |    |    |    |    |
|      | Responder IP Address, continued |   |   |   |   |   |   |   |   |   |    |    |    |    |    |    |                |    |    |    |    |    |    |    |                |    |    |    |    |    |    |    |
|      | Responder IP Address, continued |   |   |   |   |   |   |   |   |   |    |    |    |    |    |    |                |    |    |    |    |    |    |    |                |    |    |    |    |    |    |    |
|      | Policy Revision                 |   |   |   |   |   |   |   |   |   |    |    |    |    |    |    |                |    |    |    |    |    |    |    |                |    |    |    |    |    |    |    |
|      | Policy Revision, continued      |   |   |   |   |   |   |   |   |   |    |    |    |    |    |    |                |    |    |    |    |    |    |    |                |    |    |    |    |    |    |    |
|      | Policy Revision, continued      |   |   |   |   |   |   |   |   |   |    |    |    |    |    |    |                |    |    |    |    |    |    |    |                |    |    |    |    |    |    |    |
|      | Policy Revision, continued      |   |   |   |   |   |   |   |   |   |    |    |    |    |    |    |                |    |    |    |    |    |    |    |                |    |    |    |    |    |    |    |
|      | Rule ID                         |   |   |   |   |   |   |   |   |   |    |    |    |    |    |    |                |    |    |    |    |    |    |    |                |    |    |    |    |    |    |    |
|      | Rule Action                     |   |   |   |   |   |   |   |   |   |    |    |    |    |    |    | Rule Reason    |    |    |    |    |    |    |    |                |    |    |    |    |    |    |    |
|      | Initiator Port                  |   |   |   |   |   |   |   |   |   |    |    |    |    |    |    | Responder Port |    |    |    |    |    |    |    |                |    |    |    |    |    |    |    |
|      | TCP Flags                       |   |   |   |   |   |   |   |   |   |    |    |    |    |    |    | Protocol       |    |    |    |    |    |    |    | NetFlow Source |    |    |    |    |    |    |    |
|      | NetFlow Source, continued       |   |   |   |   |   |   |   |   |   |    |    |    |    |    |    |                |    |    |    |    |    |    |    |                |    |    |    |    |    |    |    |
|      | NetFlow Source, continued       |   |   |   |   |   |   |   |   |   |    |    |    |    |    |    |                |    |    |    |    |    |    |    |                |    |    |    |    |    |    |    |
|      | NetFlow Source, continued       |   |   |   |   |   |   |   |   |   |    |    |    |    |    |    |                |    |    |    |    |    |    |    |                |    |    |    |    |    |    |    |
|      | NetFlow Source, continued       |   |   |   |   |   |   |   |   |   |    |    |    |    |    |    |                |    |    |    |    |    |    |    | Instance ID    |    |    |    |    |    |    |    |

| Byte               | 0                                        |   |   |   |   |   |   |   | 1                  |   |    |    |    |    |    |    | 2                    |    |    |    |    |    |    |    | 3              |    |    |    |    |    |    |    |
|--------------------|------------------------------------------|---|---|---|---|---|---|---|--------------------|---|----|----|----|----|----|----|----------------------|----|----|----|----|----|----|----|----------------|----|----|----|----|----|----|----|
| Bit                | 0                                        | 1 | 2 | 3 | 4 | 5 | 6 | 7 | 8                  | 9 | 10 | 11 | 12 | 13 | 14 | 15 | 16                   | 17 | 18 | 19 | 20 | 21 | 22 | 23 | 24             | 25 | 26 | 27 | 28 | 29 | 30 | 31 |
|                    | Instance ID, cont.                       |   |   |   |   |   |   |   | Connection Counter |   |    |    |    |    |    |    |                      |    |    |    |    |    |    |    | First Pkt Time |    |    |    |    |    |    |    |
|                    | First Packet Timestamp, continued        |   |   |   |   |   |   |   |                    |   |    |    |    |    |    |    | Last Pkt Time        |    |    |    |    |    |    |    |                |    |    |    |    |    |    |    |
|                    | Last Packet Timestamp, continued         |   |   |   |   |   |   |   |                    |   |    |    |    |    |    |    | Initiator Tx Packets |    |    |    |    |    |    |    |                |    |    |    |    |    |    |    |
|                    | Initiator Transmitted Packets, continued |   |   |   |   |   |   |   |                    |   |    |    |    |    |    |    | Resp. Tx Packets     |    |    |    |    |    |    |    |                |    |    |    |    |    |    |    |
|                    | Initiator Transmitted Packets, continued |   |   |   |   |   |   |   |                    |   |    |    |    |    |    |    |                      |    |    |    |    |    |    |    |                |    |    |    |    |    |    |    |
|                    | Responder Transmitted Packets, continued |   |   |   |   |   |   |   |                    |   |    |    |    |    |    |    | Initiator Tx Bytes   |    |    |    |    |    |    |    |                |    |    |    |    |    |    |    |
|                    | Responder Transmitted Packets, continued |   |   |   |   |   |   |   |                    |   |    |    |    |    |    |    |                      |    |    |    |    |    |    |    |                |    |    |    |    |    |    |    |
|                    | Initiator Transmitted Bytes, continued   |   |   |   |   |   |   |   |                    |   |    |    |    |    |    |    | Resp. Tx Bytes       |    |    |    |    |    |    |    |                |    |    |    |    |    |    |    |
|                    | Initiator Transmitted Bytes, continued   |   |   |   |   |   |   |   |                    |   |    |    |    |    |    |    |                      |    |    |    |    |    |    |    |                |    |    |    |    |    |    |    |
|                    | Responder Transmitted Bytes, continued   |   |   |   |   |   |   |   |                    |   |    |    |    |    |    |    | User ID              |    |    |    |    |    |    |    |                |    |    |    |    |    |    |    |
|                    | Responder Transmitted Bytes, continued   |   |   |   |   |   |   |   |                    |   |    |    |    |    |    |    |                      |    |    |    |    |    |    |    |                |    |    |    |    |    |    |    |
|                    | User ID, continued                       |   |   |   |   |   |   |   |                    |   |    |    |    |    |    |    | Application Prot. ID |    |    |    |    |    |    |    |                |    |    |    |    |    |    |    |
|                    | Application Protocol ID, continued       |   |   |   |   |   |   |   |                    |   |    |    |    |    |    |    | URL Category         |    |    |    |    |    |    |    |                |    |    |    |    |    |    |    |
|                    | URL Category, continued                  |   |   |   |   |   |   |   |                    |   |    |    |    |    |    |    | URL Reputation       |    |    |    |    |    |    |    |                |    |    |    |    |    |    |    |
|                    | URL Reputation, continued                |   |   |   |   |   |   |   |                    |   |    |    |    |    |    |    | Client App ID        |    |    |    |    |    |    |    |                |    |    |    |    |    |    |    |
|                    | Client Application ID, continued         |   |   |   |   |   |   |   |                    |   |    |    |    |    |    |    | Web App ID           |    |    |    |    |    |    |    |                |    |    |    |    |    |    |    |
| Client URL         | Web Application ID, continued            |   |   |   |   |   |   |   |                    |   |    |    |    |    |    |    | Str. Block Type (0)  |    |    |    |    |    |    |    |                |    |    |    |    |    |    |    |
|                    | String Block Type, continued             |   |   |   |   |   |   |   |                    |   |    |    |    |    |    |    | String Block Length  |    |    |    |    |    |    |    |                |    |    |    |    |    |    |    |
|                    | String Block Length, continued           |   |   |   |   |   |   |   |                    |   |    |    |    |    |    |    | Client App. URL...   |    |    |    |    |    |    |    |                |    |    |    |    |    |    |    |
| NetBIOS Name       | String Block Type (0)                    |   |   |   |   |   |   |   |                    |   |    |    |    |    |    |    |                      |    |    |    |    |    |    |    |                |    |    |    |    |    |    |    |
|                    | String Block Length                      |   |   |   |   |   |   |   |                    |   |    |    |    |    |    |    |                      |    |    |    |    |    |    |    |                |    |    |    |    |    |    |    |
|                    | NetBIOS Name...                          |   |   |   |   |   |   |   |                    |   |    |    |    |    |    |    |                      |    |    |    |    |    |    |    |                |    |    |    |    |    |    |    |
| Client App Version | String Block Type (0)                    |   |   |   |   |   |   |   |                    |   |    |    |    |    |    |    |                      |    |    |    |    |    |    |    |                |    |    |    |    |    |    |    |
|                    | String Block Length                      |   |   |   |   |   |   |   |                    |   |    |    |    |    |    |    |                      |    |    |    |    |    |    |    |                |    |    |    |    |    |    |    |
|                    | Client Application Version...            |   |   |   |   |   |   |   |                    |   |    |    |    |    |    |    |                      |    |    |    |    |    |    |    |                |    |    |    |    |    |    |    |

|      |                       |   |   |   |   |   |   |   |                 |   |    |    |    |    |    |    |                   |    |    |    |    |    |    |    |    |    |    |    |    |    |    |    |
|------|-----------------------|---|---|---|---|---|---|---|-----------------|---|----|----|----|----|----|----|-------------------|----|----|----|----|----|----|----|----|----|----|----|----|----|----|----|
| Byte | 0                     |   |   |   |   |   |   |   | 1               |   |    |    |    |    |    |    | 2                 |    |    |    |    |    |    |    | 3  |    |    |    |    |    |    |    |
| Bit  | 0                     | 1 | 2 | 3 | 4 | 5 | 6 | 7 | 8               | 9 | 10 | 11 | 12 | 13 | 14 | 15 | 16                | 17 | 18 | 19 | 20 | 21 | 22 | 23 | 24 | 25 | 26 | 27 | 28 | 29 | 30 | 31 |
|      | Monitor Rule 1        |   |   |   |   |   |   |   |                 |   |    |    |    |    |    |    |                   |    |    |    |    |    |    |    |    |    |    |    |    |    |    |    |
|      | Monitor Rule 2        |   |   |   |   |   |   |   |                 |   |    |    |    |    |    |    |                   |    |    |    |    |    |    |    |    |    |    |    |    |    |    |    |
|      | Monitor Rule 3        |   |   |   |   |   |   |   |                 |   |    |    |    |    |    |    |                   |    |    |    |    |    |    |    |    |    |    |    |    |    |    |    |
|      | Monitor Rule 4        |   |   |   |   |   |   |   |                 |   |    |    |    |    |    |    |                   |    |    |    |    |    |    |    |    |    |    |    |    |    |    |    |
|      | Monitor Rule 5        |   |   |   |   |   |   |   |                 |   |    |    |    |    |    |    |                   |    |    |    |    |    |    |    |    |    |    |    |    |    |    |    |
|      | Monitor Rule 6        |   |   |   |   |   |   |   |                 |   |    |    |    |    |    |    |                   |    |    |    |    |    |    |    |    |    |    |    |    |    |    |    |
|      | Monitor Rule 7        |   |   |   |   |   |   |   |                 |   |    |    |    |    |    |    |                   |    |    |    |    |    |    |    |    |    |    |    |    |    |    |    |
|      | Monitor Rule 8        |   |   |   |   |   |   |   |                 |   |    |    |    |    |    |    |                   |    |    |    |    |    |    |    |    |    |    |    |    |    |    |    |
|      | Sec. Int. Src/Dst     |   |   |   |   |   |   |   | Sec. Int. Layer |   |    |    |    |    |    |    | File Event Count  |    |    |    |    |    |    |    |    |    |    |    |    |    |    |    |
|      | Intrusion Event Count |   |   |   |   |   |   |   |                 |   |    |    |    |    |    |    | Initiator Country |    |    |    |    |    |    |    |    |    |    |    |    |    |    |    |
|      | Responder Country     |   |   |   |   |   |   |   |                 |   |    |    |    |    |    |    |                   |    |    |    |    |    |    |    |    |    |    |    |    |    |    |    |

The following table describes the fields of the Connection Statistics data block for 5.2.x:

**Table B-21** Connection Statistics Data Block 5.2.x Fields

| Field                                   | Data Type | Description                                                                                                                                                                                              |
|-----------------------------------------|-----------|----------------------------------------------------------------------------------------------------------------------------------------------------------------------------------------------------------|
| Connection Statistics Data Block Type   | uint32    | Initiates a Connection Statistics data block for 5.2.x. The value is always 144.                                                                                                                         |
| Connection Statistics Data Block Length | uint32    | Number of bytes in the Connection Statistics data block, including eight bytes for the connection statistics block type and length fields, plus the number of bytes in the connection data that follows. |
| Device ID                               | uint32    | The device that detected the connection event.                                                                                                                                                           |
| Ingress Zone                            | uint8[16] | Ingress security zone in the event that triggered the policy violation.                                                                                                                                  |
| Egress Zone                             | uint8[16] | Egress security zone in the event that triggered the policy violation.                                                                                                                                   |
| Ingress Interface                       | uint8[16] | Interface for the inbound traffic.                                                                                                                                                                       |
| Egress Interface                        | uint8[16] | Interface for the outbound traffic.                                                                                                                                                                      |
| Initiator IP Address                    | uint8[16] | IP address of the host that initiated the session described in the connection event, in IP address octets.                                                                                               |
| Responder IP Address                    | uint8[16] | IP address of the host that responded to the initiating host, in IP address octets.                                                                                                                      |

Table B-21 Connection Statistics Data Block 5.2.x Fields (continued)

| Field                         | Data Type | Description                                                                                           |
|-------------------------------|-----------|-------------------------------------------------------------------------------------------------------|
| Policy Revision               | uint8[16] | Revision number of the rule associated with the triggered correlation event, if applicable.           |
| Rule ID                       | uint32    | Internal identifier for the rule that triggered the event, if applicable.                             |
| Rule Action                   | uint16    | The action selected in the user interface for that rule (allow, block, and so forth).                 |
| Rule Reason                   | uint16    | The reason the rule triggered the event.                                                              |
| Initiator Port                | uint16    | Port used by the initiating host.                                                                     |
| Responder Port                | uint16    | Port used by the responding host.                                                                     |
| TCP Flags                     | uint16    | Indicates any TCP flags for the connection event.                                                     |
| Protocol                      | uint8     | The IANA-specified protocol number.                                                                   |
| NetFlow Source                | uint8[16] | IP address of the NetFlow-enabled device that exported the data for the connection.                   |
| Instance ID                   | uint16    | Numerical ID of the Snort instance on the managed device that generated the event.                    |
| Connection Counter            | uint16    | Value used to distinguish between connection events that happen during the same second.               |
| First Packet Timestamp        | uint32    | UNIX timestamp of the date and time the first packet was exchanged in the session.                    |
| Last Packet Timestamp         | uint32    | UNIX timestamp of the date and time the last packet was exchanged in the session.                     |
| Initiator Transmitted Packets | uint64    | Number of packets transmitted by the initiating host.                                                 |
| Responder Transmitted Packets | uint64    | Number of packets transmitted by the responding host.                                                 |
| Initiator Transmitted Bytes   | uint64    | Number of bytes transmitted by the initiating host.                                                   |
| Responder Transmitted Bytes   | uint64    | Number of bytes transmitted by the responding host.                                                   |
| User ID                       | uint32    | Internal identification number for the user who last logged into the host that generated the traffic. |
| Application Protocol ID       | uint32    | Application ID of the application protocol.                                                           |
| URL Category                  | uint32    | The internal identification number of the URL category.                                               |
| URL Reputation                | uint32    | The internal identification number for the URL reputation.                                            |
| Client Application ID         | uint32    | The internal identification number of the detected client application, if applicable.                 |
| Web Application ID            | uint32    | The internal identification number of the detected web application, if applicable.                    |
| String Block Type             | uint32    | Initiates a String data block for the client application URL. This value is always 0.                 |

Table B-21 Connection Statistics Data Block 5.2.x Fields (continued)

| Field                                     | Data Type | Description                                                                                                                                                                                        |
|-------------------------------------------|-----------|----------------------------------------------------------------------------------------------------------------------------------------------------------------------------------------------------|
| String Block Length                       | uint32    | Number of bytes in the client application URL String data block, including eight bytes for the string block type and length fields, plus the number of bytes in the client application URL string. |
| Client Application URL                    | string    | URL the client application accessed, if applicable (/files/index.html, for example).                                                                                                               |
| String Block Type                         | uint32    | Initiates a String data block for the host NetBIOS name. This value is always 0.                                                                                                                   |
| String Block Length                       | uint32    | Number of bytes in the String data block, including eight bytes for the string block type and length fields, plus the number of bytes in the NetBIOS name string.                                  |
| NetBIOS Name                              | string    | Host NetBIOS name string.                                                                                                                                                                          |
| String Block Type                         | uint32    | Initiates a String data block for the client application version. This value is always 0.                                                                                                          |
| String Block Length                       | uint32    | Number of bytes in the String data block for the client application version, including eight bytes for the string block type and length, plus the number of bytes in the version.                  |
| Client Application Version                | string    | Client application version.                                                                                                                                                                        |
| Monitor Rule 1                            | uint32    | The ID of the first monitor rule associated with the connection event.                                                                                                                             |
| Monitor Rule 2                            | uint32    | The ID of the second monitor rule associated with the connection event.                                                                                                                            |
| Monitor Rule 3                            | uint32    | The ID of the third monitor rule associated with the connection event.                                                                                                                             |
| Monitor Rule 4                            | uint32    | The ID of the fourth monitor rule associated with the connection event.                                                                                                                            |
| Monitor Rule 5                            | uint32    | The ID of the fifth monitor rule associated with the connection event.                                                                                                                             |
| Monitor Rule 6                            | uint32    | The ID of the sixth monitor rule associated with the connection event.                                                                                                                             |
| Monitor Rule 7                            | uint32    | The ID of the seventh monitor rule associated with the connection event.                                                                                                                           |
| Monitor Rule 8                            | uint32    | The ID of the eighth monitor rule associated with the connection event.                                                                                                                            |
| Security Intelligence Source/ Destination | uint8     | Whether the source or destination IP address matched the IP blacklist.                                                                                                                             |
| Security Intelligence Layer               | uint8     | The IP layer that matched the IP blacklist.                                                                                                                                                        |
| File Event Count                          | uint16    | Value used to distinguish between file events that happen during the same second.                                                                                                                  |

Table B-21 Connection Statistics Data Block 5.2.x Fields (continued)

| Field                 | Data Type | Description                                                                            |
|-----------------------|-----------|----------------------------------------------------------------------------------------|
| Intrusion Event Count | uint16    | Value used to distinguish between intrusion events that happen during the same second. |
| Initiator Country     | uint16    | Code for the country of the initiating host.                                           |
| Responder Country     | uint16    | Code for the country of the responding host.                                           |

## Connection Chunk Data Block for 5.0 - 5.1

The Connection Chunk data block conveys connection data detected by a NetFlow device. The Connection Chunk data block has a block type of 66 for pre-4.10.1 versions. For versions 5.0 - 5.1, it has a block type of 119.

The following diagram shows the format of the Connection Chunk data block:

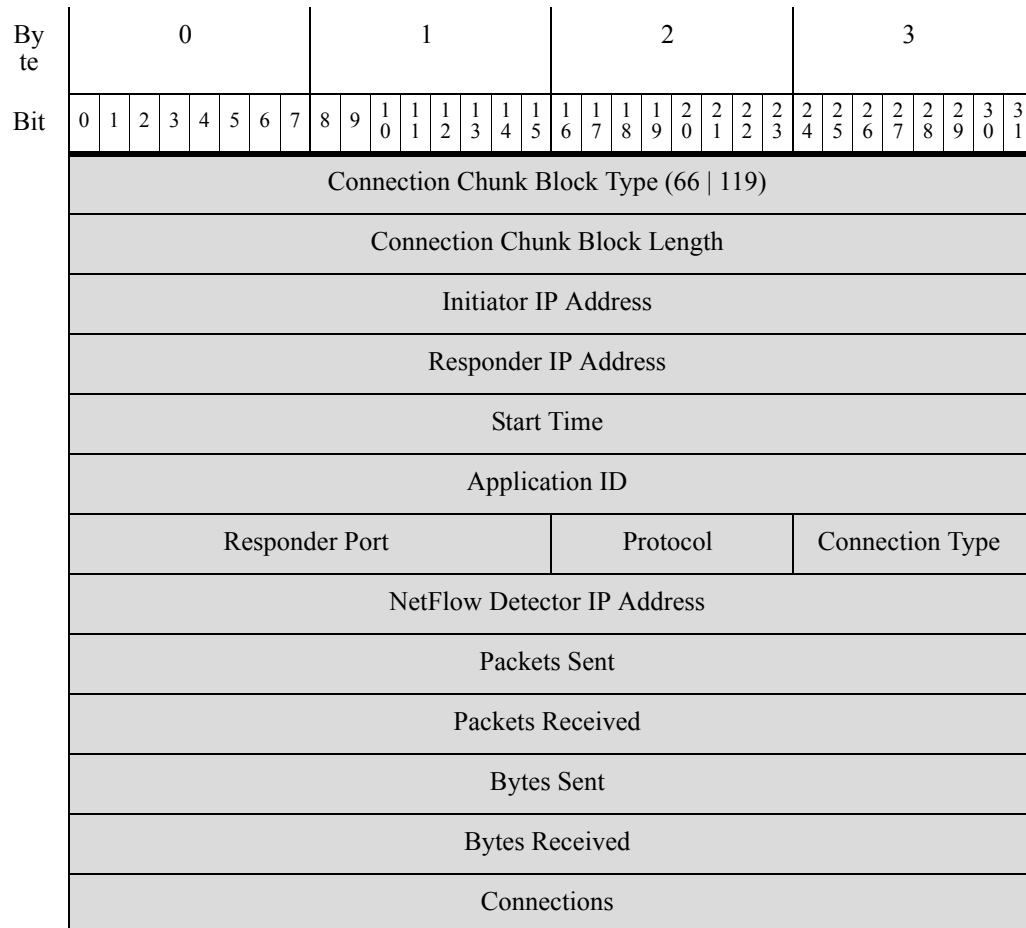

The following table describes the components of the Connection Chunk data block:

Table B-22 Connection Chunk Data Block Fields

| Field                         | Data Type | Description                                                                                                                                                                                                |
|-------------------------------|-----------|------------------------------------------------------------------------------------------------------------------------------------------------------------------------------------------------------------|
| Connection Chunk Block Type   | uint32    | Initiates a Connection Chunk data block. This value is 66 for versions before 4.10.1 and a value of 119 for version 5.0.                                                                                   |
| Connection Chunk Block Length | uint32    | Total number of bytes in the Connection Chunk data block, including eight bytes for the connection chunk block type and length fields, plus the number of bytes in the connection chunk data that follows. |
| Initiator IP Address          | uint8[4]  | IP address of the host that initiated the connection, in IP address octets.                                                                                                                                |
| Responder IP Address          | uint8[4]  | IP address of the host that responded to the initiating host, in IP address octets.                                                                                                                        |
| Start Time                    | uint32    | The starting time for the connection chunk.                                                                                                                                                                |
| Application ID                | uint32    | Application identification number for the application protocol used in the connection.                                                                                                                     |
| Responder Port                | uint16    | The port used by the responder in the connection chunk.                                                                                                                                                    |
| Protocol                      | uint8     | The protocol for the packet containing the user information.                                                                                                                                               |
| Connection Type               | uint8     | The type of connection.                                                                                                                                                                                    |
| Source Device IP Address      | uint8[4]  | IP address of the NetFlow device that detected the connection, in IP address octets.                                                                                                                       |
| Packets Sent                  | uint32    | The number of packets sent in the connection chunk.                                                                                                                                                        |
| Packets Received              | uint32    | The number of packets received in the connection chunk.                                                                                                                                                    |
| Bytes Sent                    | uint32    | The number of bytes sent in the connection chunk.                                                                                                                                                          |
| Bytes Received                | uint32    | The number of bytes received in the connection chunk.                                                                                                                                                      |
| Connections                   | uint32    | The number of connections made in the connection chunk.                                                                                                                                                    |

## Connection Statistics Data Block 5.1.1.x

The connection statistics data block is used in connection data messages. Changes to the connection data block between versions 5.1 and 5.1.1 include the addition of new fields to identify associated intrusion events. The connection statistics data block for version 5.1.1.x has a block type of 137. It deprecates block type 126, [Connection Statistics Data Block 5.1, page B-83](#).

For more information on the Connection Statistics Data message, see [Connection Statistics Data Message, page 4-46](#).

The following diagram shows the format of a Connection Statistics data block for 5.1.1:

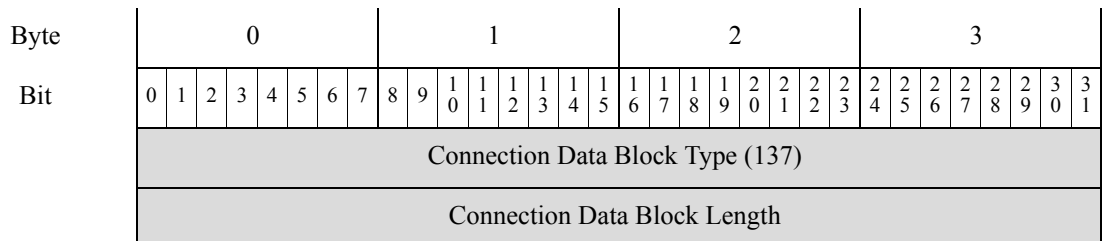



| Byte | 0                               |   |   |   |   |   |   |   | 1 |   |    |    |    |    |    |    | 2  |    |    |    |    |    |    |    | 3  |    |    |    |    |    |    |    |
|------|---------------------------------|---|---|---|---|---|---|---|---|---|----|----|----|----|----|----|----|----|----|----|----|----|----|----|----|----|----|----|----|----|----|----|
| Bit  | 0                               | 1 | 2 | 3 | 4 | 5 | 6 | 7 | 8 | 9 | 10 | 11 | 12 | 13 | 14 | 15 | 16 | 17 | 18 | 19 | 20 | 21 | 22 | 23 | 24 | 25 | 26 | 27 | 28 | 29 | 30 | 31 |
|      | Device ID                       |   |   |   |   |   |   |   |   |   |    |    |    |    |    |    |    |    |    |    |    |    |    |    |    |    |    |    |    |    |    |    |
|      | Ingress Zone                    |   |   |   |   |   |   |   |   |   |    |    |    |    |    |    |    |    |    |    |    |    |    |    |    |    |    |    |    |    |    |    |
|      | Ingress Zone, continued         |   |   |   |   |   |   |   |   |   |    |    |    |    |    |    |    |    |    |    |    |    |    |    |    |    |    |    |    |    |    |    |
|      | Ingress Zone, continued         |   |   |   |   |   |   |   |   |   |    |    |    |    |    |    |    |    |    |    |    |    |    |    |    |    |    |    |    |    |    |    |
|      | Ingress Zone, continued         |   |   |   |   |   |   |   |   |   |    |    |    |    |    |    |    |    |    |    |    |    |    |    |    |    |    |    |    |    |    |    |
|      | Egress Zone                     |   |   |   |   |   |   |   |   |   |    |    |    |    |    |    |    |    |    |    |    |    |    |    |    |    |    |    |    |    |    |    |
|      | Egress Zone, continued          |   |   |   |   |   |   |   |   |   |    |    |    |    |    |    |    |    |    |    |    |    |    |    |    |    |    |    |    |    |    |    |
|      | Egress Zone, continued          |   |   |   |   |   |   |   |   |   |    |    |    |    |    |    |    |    |    |    |    |    |    |    |    |    |    |    |    |    |    |    |
|      | Egress Zone, continued          |   |   |   |   |   |   |   |   |   |    |    |    |    |    |    |    |    |    |    |    |    |    |    |    |    |    |    |    |    |    |    |
|      | Ingress Interface               |   |   |   |   |   |   |   |   |   |    |    |    |    |    |    |    |    |    |    |    |    |    |    |    |    |    |    |    |    |    |    |
|      | Ingress Interface, continued    |   |   |   |   |   |   |   |   |   |    |    |    |    |    |    |    |    |    |    |    |    |    |    |    |    |    |    |    |    |    |    |
|      | Ingress Interface, continued    |   |   |   |   |   |   |   |   |   |    |    |    |    |    |    |    |    |    |    |    |    |    |    |    |    |    |    |    |    |    |    |
|      | Ingress Interface, continued    |   |   |   |   |   |   |   |   |   |    |    |    |    |    |    |    |    |    |    |    |    |    |    |    |    |    |    |    |    |    |    |
|      | Egress Interface                |   |   |   |   |   |   |   |   |   |    |    |    |    |    |    |    |    |    |    |    |    |    |    |    |    |    |    |    |    |    |    |
|      | Egress Interface, continued     |   |   |   |   |   |   |   |   |   |    |    |    |    |    |    |    |    |    |    |    |    |    |    |    |    |    |    |    |    |    |    |
|      | Egress Interface, continued     |   |   |   |   |   |   |   |   |   |    |    |    |    |    |    |    |    |    |    |    |    |    |    |    |    |    |    |    |    |    |    |
|      | Egress Interface, continued     |   |   |   |   |   |   |   |   |   |    |    |    |    |    |    |    |    |    |    |    |    |    |    |    |    |    |    |    |    |    |    |
|      | Initiator IP Address            |   |   |   |   |   |   |   |   |   |    |    |    |    |    |    |    |    |    |    |    |    |    |    |    |    |    |    |    |    |    |    |
|      | Initiator IP Address, continued |   |   |   |   |   |   |   |   |   |    |    |    |    |    |    |    |    |    |    |    |    |    |    |    |    |    |    |    |    |    |    |
|      | Initiator IP Address, continued |   |   |   |   |   |   |   |   |   |    |    |    |    |    |    |    |    |    |    |    |    |    |    |    |    |    |    |    |    |    |    |
|      | Initiator IP Address, continued |   |   |   |   |   |   |   |   |   |    |    |    |    |    |    |    |    |    |    |    |    |    |    |    |    |    |    |    |    |    |    |
|      | Responder IP Address            |   |   |   |   |   |   |   |   |   |    |    |    |    |    |    |    |    |    |    |    |    |    |    |    |    |    |    |    |    |    |    |
|      | Responder IP Address, continued |   |   |   |   |   |   |   |   |   |    |    |    |    |    |    |    |    |    |    |    |    |    |    |    |    |    |    |    |    |    |    |
|      | Responder IP Address, continued |   |   |   |   |   |   |   |   |   |    |    |    |    |    |    |    |    |    |    |    |    |    |    |    |    |    |    |    |    |    |    |
|      | Responder IP Address, continued |   |   |   |   |   |   |   |   |   |    |    |    |    |    |    |    |    |    |    |    |    |    |    |    |    |    |    |    |    |    |    |
|      | Policy Revision                 |   |   |   |   |   |   |   |   |   |    |    |    |    |    |    |    |    |    |    |    |    |    |    |    |    |    |    |    |    |    |    |

|      |                                          |   |   |   |   |   |   |   |                    |   |    |    |    |    |    |    |                |    |    |    |    |    |    |    |                      |    |    |    |    |    |    |    |
|------|------------------------------------------|---|---|---|---|---|---|---|--------------------|---|----|----|----|----|----|----|----------------|----|----|----|----|----|----|----|----------------------|----|----|----|----|----|----|----|
| Byte | 0                                        |   |   |   |   |   |   |   | 1                  |   |    |    |    |    |    |    | 2              |    |    |    |    |    |    |    | 3                    |    |    |    |    |    |    |    |
| Bit  | 0                                        | 1 | 2 | 3 | 4 | 5 | 6 | 7 | 8                  | 9 | 10 | 11 | 12 | 13 | 14 | 15 | 16             | 17 | 18 | 19 | 20 | 21 | 22 | 23 | 24                   | 25 | 26 | 27 | 28 | 29 | 30 | 31 |
|      | Policy Revision, continued               |   |   |   |   |   |   |   |                    |   |    |    |    |    |    |    |                |    |    |    |    |    |    |    |                      |    |    |    |    |    |    |    |
|      | Policy Revision, continued               |   |   |   |   |   |   |   |                    |   |    |    |    |    |    |    |                |    |    |    |    |    |    |    |                      |    |    |    |    |    |    |    |
|      | Policy Revision, continued               |   |   |   |   |   |   |   |                    |   |    |    |    |    |    |    |                |    |    |    |    |    |    |    |                      |    |    |    |    |    |    |    |
|      | Rule ID                                  |   |   |   |   |   |   |   |                    |   |    |    |    |    |    |    |                |    |    |    |    |    |    |    |                      |    |    |    |    |    |    |    |
|      | Rule Action                              |   |   |   |   |   |   |   |                    |   |    |    |    |    |    |    | Rule Reason    |    |    |    |    |    |    |    |                      |    |    |    |    |    |    |    |
|      | Initiator Port                           |   |   |   |   |   |   |   |                    |   |    |    |    |    |    |    | Responder Port |    |    |    |    |    |    |    |                      |    |    |    |    |    |    |    |
|      | TCP Flags                                |   |   |   |   |   |   |   |                    |   |    |    |    |    |    |    | Protocol       |    |    |    |    |    |    |    | NetFlow Source       |    |    |    |    |    |    |    |
|      | NetFlow Source, continued                |   |   |   |   |   |   |   |                    |   |    |    |    |    |    |    |                |    |    |    |    |    |    |    |                      |    |    |    |    |    |    |    |
|      | NetFlow Source, continued                |   |   |   |   |   |   |   |                    |   |    |    |    |    |    |    |                |    |    |    |    |    |    |    |                      |    |    |    |    |    |    |    |
|      | NetFlow Source, continued                |   |   |   |   |   |   |   |                    |   |    |    |    |    |    |    |                |    |    |    |    |    |    |    |                      |    |    |    |    |    |    |    |
|      | NetFlow Source, continued                |   |   |   |   |   |   |   |                    |   |    |    |    |    |    |    |                |    |    |    |    |    |    |    | Instance ID          |    |    |    |    |    |    |    |
|      | Instance ID, cont.                       |   |   |   |   |   |   |   | Connection Counter |   |    |    |    |    |    |    |                |    |    |    |    |    |    |    | First Pkt Time       |    |    |    |    |    |    |    |
|      | First Packet Timestamp, continued        |   |   |   |   |   |   |   |                    |   |    |    |    |    |    |    |                |    |    |    |    |    |    |    | Last Pkt Time        |    |    |    |    |    |    |    |
|      | Last Packet Timestamp, continued         |   |   |   |   |   |   |   |                    |   |    |    |    |    |    |    |                |    |    |    |    |    |    |    | Initiator Tx Packets |    |    |    |    |    |    |    |
|      | Initiator Transmitted Packets, continued |   |   |   |   |   |   |   |                    |   |    |    |    |    |    |    |                |    |    |    |    |    |    |    |                      |    |    |    |    |    |    |    |
|      | Initiator Transmitted Packets, continued |   |   |   |   |   |   |   |                    |   |    |    |    |    |    |    |                |    |    |    |    |    |    |    | Resp. Tx Packets     |    |    |    |    |    |    |    |
|      | Responder Transmitted Packets, continued |   |   |   |   |   |   |   |                    |   |    |    |    |    |    |    |                |    |    |    |    |    |    |    |                      |    |    |    |    |    |    |    |
|      | Responder Transmitted Packets, continued |   |   |   |   |   |   |   |                    |   |    |    |    |    |    |    |                |    |    |    |    |    |    |    | Initiator Tx Bytes   |    |    |    |    |    |    |    |
|      | Initiator Transmitted Bytes, continued   |   |   |   |   |   |   |   |                    |   |    |    |    |    |    |    |                |    |    |    |    |    |    |    |                      |    |    |    |    |    |    |    |
|      | Initiator Transmitted Bytes, continued   |   |   |   |   |   |   |   |                    |   |    |    |    |    |    |    |                |    |    |    |    |    |    |    | Resp. Tx Bytes       |    |    |    |    |    |    |    |
|      | Responder Transmitted Bytes, continued   |   |   |   |   |   |   |   |                    |   |    |    |    |    |    |    |                |    |    |    |    |    |    |    |                      |    |    |    |    |    |    |    |
|      | Responder Transmitted Bytes, continued   |   |   |   |   |   |   |   |                    |   |    |    |    |    |    |    |                |    |    |    |    |    |    |    | User ID              |    |    |    |    |    |    |    |
|      | User ID, continued                       |   |   |   |   |   |   |   |                    |   |    |    |    |    |    |    |                |    |    |    |    |    |    |    |                      |    |    |    |    |    |    |    |
|      | Application Protocol ID, continued       |   |   |   |   |   |   |   |                    |   |    |    |    |    |    |    |                |    |    |    |    |    |    |    | Application Prot. ID |    |    |    |    |    |    |    |
|      | Application Protocol ID, continued       |   |   |   |   |   |   |   |                    |   |    |    |    |    |    |    |                |    |    |    |    |    |    |    |                      |    |    |    |    |    |    |    |
|      | URL Category, continued                  |   |   |   |   |   |   |   |                    |   |    |    |    |    |    |    |                |    |    |    |    |    |    |    | URL Reputation       |    |    |    |    |    |    |    |
|      | URL Category, continued                  |   |   |   |   |   |   |   |                    |   |    |    |    |    |    |    |                |    |    |    |    |    |    |    |                      |    |    |    |    |    |    |    |

| Byte               | 0                                |   |   |   |   |   |   |   | 1               |   |    |    |    |    |    |    | 2                   |    |    |    |    |    |    |    | 3  |    |    |    |    |    |    |    |
|--------------------|----------------------------------|---|---|---|---|---|---|---|-----------------|---|----|----|----|----|----|----|---------------------|----|----|----|----|----|----|----|----|----|----|----|----|----|----|----|
| Bit                | 0                                | 1 | 2 | 3 | 4 | 5 | 6 | 7 | 8               | 9 | 10 | 11 | 12 | 13 | 14 | 15 | 16                  | 17 | 18 | 19 | 20 | 21 | 22 | 23 | 24 | 25 | 26 | 27 | 28 | 29 | 30 | 31 |
|                    | URL Reputation, continued        |   |   |   |   |   |   |   |                 |   |    |    |    |    |    |    | Client App ID       |    |    |    |    |    |    |    |    |    |    |    |    |    |    |    |
|                    | Client Application ID, continued |   |   |   |   |   |   |   |                 |   |    |    |    |    |    |    | Web App ID          |    |    |    |    |    |    |    |    |    |    |    |    |    |    |    |
| Client URL         | Web Application ID, continued    |   |   |   |   |   |   |   |                 |   |    |    |    |    |    |    | Str. Block Type (0) |    |    |    |    |    |    |    |    |    |    |    |    |    |    |    |
|                    | String Block Type, continued     |   |   |   |   |   |   |   |                 |   |    |    |    |    |    |    | String Block Length |    |    |    |    |    |    |    |    |    |    |    |    |    |    |    |
|                    | String Block Length, continued   |   |   |   |   |   |   |   |                 |   |    |    |    |    |    |    | Client App. URL...  |    |    |    |    |    |    |    |    |    |    |    |    |    |    |    |
| NetBIOS Name       | String Block Type (0)            |   |   |   |   |   |   |   |                 |   |    |    |    |    |    |    |                     |    |    |    |    |    |    |    |    |    |    |    |    |    |    |    |
|                    | String Block Length              |   |   |   |   |   |   |   |                 |   |    |    |    |    |    |    |                     |    |    |    |    |    |    |    |    |    |    |    |    |    |    |    |
|                    | NetBIOS Name...                  |   |   |   |   |   |   |   |                 |   |    |    |    |    |    |    |                     |    |    |    |    |    |    |    |    |    |    |    |    |    |    |    |
| Client App Version | String Block Type (0)            |   |   |   |   |   |   |   |                 |   |    |    |    |    |    |    |                     |    |    |    |    |    |    |    |    |    |    |    |    |    |    |    |
|                    | String Block Length              |   |   |   |   |   |   |   |                 |   |    |    |    |    |    |    |                     |    |    |    |    |    |    |    |    |    |    |    |    |    |    |    |
|                    | Client Application Version...    |   |   |   |   |   |   |   |                 |   |    |    |    |    |    |    |                     |    |    |    |    |    |    |    |    |    |    |    |    |    |    |    |
|                    | Monitor Rule 1                   |   |   |   |   |   |   |   |                 |   |    |    |    |    |    |    |                     |    |    |    |    |    |    |    |    |    |    |    |    |    |    |    |
|                    | Monitor Rule 2                   |   |   |   |   |   |   |   |                 |   |    |    |    |    |    |    |                     |    |    |    |    |    |    |    |    |    |    |    |    |    |    |    |
|                    | Monitor Rule 3                   |   |   |   |   |   |   |   |                 |   |    |    |    |    |    |    |                     |    |    |    |    |    |    |    |    |    |    |    |    |    |    |    |
|                    | Monitor Rule 4                   |   |   |   |   |   |   |   |                 |   |    |    |    |    |    |    |                     |    |    |    |    |    |    |    |    |    |    |    |    |    |    |    |
|                    | Monitor Rule 5                   |   |   |   |   |   |   |   |                 |   |    |    |    |    |    |    |                     |    |    |    |    |    |    |    |    |    |    |    |    |    |    |    |
|                    | Monitor Rule 6                   |   |   |   |   |   |   |   |                 |   |    |    |    |    |    |    |                     |    |    |    |    |    |    |    |    |    |    |    |    |    |    |    |
|                    | Monitor Rule 7                   |   |   |   |   |   |   |   |                 |   |    |    |    |    |    |    |                     |    |    |    |    |    |    |    |    |    |    |    |    |    |    |    |
|                    | Monitor Rule 8                   |   |   |   |   |   |   |   |                 |   |    |    |    |    |    |    |                     |    |    |    |    |    |    |    |    |    |    |    |    |    |    |    |
|                    | Sec. Int. Src/Dst                |   |   |   |   |   |   |   | Sec. Int. Layer |   |    |    |    |    |    |    | File Event Count    |    |    |    |    |    |    |    |    |    |    |    |    |    |    |    |
|                    | Intrusion Event Count            |   |   |   |   |   |   |   |                 |   |    |    |    |    |    |    |                     |    |    |    |    |    |    |    |    |    |    |    |    |    |    |    |

The following table describes the fields of the Connection Statistics data block for 5.1.1.x.

Table B-23 Connection Statistics Data Block 5.1.1.x Fields

| Field                                   | Data Type | Description                                                                                                                                                                                              |
|-----------------------------------------|-----------|----------------------------------------------------------------------------------------------------------------------------------------------------------------------------------------------------------|
| Connection Statistics Data Block Type   | uint32    | Initiates a Connection Statistics data block for 5.1.1.x. The value is always 137.                                                                                                                       |
| Connection Statistics Data Block Length | uint32    | Number of bytes in the Connection Statistics data block, including eight bytes for the connection statistics block type and length fields, plus the number of bytes in the connection data that follows. |
| Device ID                               | uint32    | The device that detected the connection event.                                                                                                                                                           |
| Ingress Zone                            | uint8[16] | Ingress security zone in the event that triggered the policy violation.                                                                                                                                  |
| Egress Zone                             | uint8[16] | Egress security zone in the event that triggered the policy violation.                                                                                                                                   |
| Ingress Interface                       | uint8[16] | Interface for the inbound traffic.                                                                                                                                                                       |
| Egress Interface                        | uint8[16] | Interface for the outbound traffic.                                                                                                                                                                      |
| Initiator IP Address                    | uint8[16] | IP address of the host that initiated the session described in the connection event, in IP address octets.                                                                                               |
| Responder IP Address                    | uint8[16] | IP address of the host that responded to the initiating host, in IP address octets.                                                                                                                      |
| Policy Revision                         | uint8[16] | Revision number of the rule associated with the triggered correlation event, if applicable.                                                                                                              |
| Rule ID                                 | uint32    | Internal identifier for the rule that triggered the event, if applicable.                                                                                                                                |
| Rule Action                             | uint16    | The action selected in the user interface for that rule (allow, block, and so forth).                                                                                                                    |
| Rule Reason                             | uint16    | The reason the rule triggered the event.                                                                                                                                                                 |
| Initiator Port                          | uint16    | Port used by the initiating host.                                                                                                                                                                        |
| Responder Port                          | uint16    | Port used by the responding host.                                                                                                                                                                        |
| TCP Flags                               | uint16    | Indicates any TCP flags for the connection event.                                                                                                                                                        |
| Protocol                                | uint8     | The IANA-specified protocol number.                                                                                                                                                                      |
| NetFlow Source                          | uint8[16] | IP address of the NetFlow-enabled device that exported the data for the connection.                                                                                                                      |
| Instance ID                             | uint16    | Numerical ID of the Snort instance on the managed device that generated the event.                                                                                                                       |
| Connection Counter                      | uint16    | Value used to distinguish between connection events that happen during the same second.                                                                                                                  |
| First Packet Timestamp                  | uint32    | UNIX timestamp of the date and time the first packet was exchanged in the session.                                                                                                                       |
| Last Packet Timestamp                   | uint32    | UNIX timestamp of the date and time the last packet was exchanged in the session.                                                                                                                        |

Table B-23 Connection Statistics Data Block 5.1.1.x Fields (continued)

| Field                         | Data Type | Description                                                                                                                                                                                        |
|-------------------------------|-----------|----------------------------------------------------------------------------------------------------------------------------------------------------------------------------------------------------|
| Initiator Transmitted Packets | uint64    | Number of packets transmitted by the initiating host.                                                                                                                                              |
| Responder Transmitted Packets | uint64    | Number of packets transmitted by the responding host.                                                                                                                                              |
| Initiator Transmitted Bytes   | uint64    | Number of bytes transmitted by the initiating host.                                                                                                                                                |
| Responder Transmitted Bytes   | uint64    | Number of bytes transmitted by the responding host.                                                                                                                                                |
| User ID                       | uint32    | Internal identification number for the user who last logged into the host that generated the traffic.                                                                                              |
| Application Protocol ID       | uint32    | Application ID of the application protocol.                                                                                                                                                        |
| URL Category                  | uint32    | The internal identification number of the URL category.                                                                                                                                            |
| URL Reputation                | uint32    | The internal identification number for the URL reputation.                                                                                                                                         |
| Client Application ID         | uint32    | The internal identification number of the detected client application, if applicable.                                                                                                              |
| Web Application ID            | uint32    | The internal identification number of the detected web application, if applicable.                                                                                                                 |
| String Block Type             | uint32    | Initiates a String data block for the client application URL. This value is always 0.                                                                                                              |
| String Block Length           | uint32    | Number of bytes in the client application URL String data block, including eight bytes for the string block type and length fields, plus the number of bytes in the client application URL string. |
| Client Application URL        | string    | URL the client application accessed, if applicable (/files/index.html, for example).                                                                                                               |
| String Block Type             | uint32    | Initiates a String data block for the host NetBIOS name. This value is always 0.                                                                                                                   |
| String Block Length           | uint32    | Number of bytes in the String data block, including eight bytes for the string block type and length fields, plus the number of bytes in the NetBIOS name string.                                  |
| NetBIOS Name                  | string    | Host NetBIOS name string.                                                                                                                                                                          |
| String Block Type             | uint32    | Initiates a String data block for the client application version. This value is always 0.                                                                                                          |
| String Block Length           | uint32    | Number of bytes in the String data block for the client application version, including eight bytes for the string block type and length, plus the number of bytes in the version.                  |
| Client Application Version    | string    | Client application version.                                                                                                                                                                        |

Table B-23 Connection Statistics Data Block 5.1.1.x Fields (continued)

| Field                                     | Data Type | Description                                                                            |
|-------------------------------------------|-----------|----------------------------------------------------------------------------------------|
| Monitor Rule 1                            | uint32    | The ID of the first monitor rule associated with the connection event.                 |
| Monitor Rule 2                            | uint32    | The ID of the second monitor rule associated with the connection event.                |
| Monitor Rule 3                            | uint32    | The ID of the third monitor rule associated with the connection event.                 |
| Monitor Rule 4                            | uint32    | The ID of the fourth monitor rule associated with the connection event.                |
| Monitor Rule 5                            | uint32    | The ID of the fifth monitor rule associated with the connection event.                 |
| Monitor Rule 6                            | uint32    | The ID of the sixth monitor rule associated with the connection event.                 |
| Monitor Rule 7                            | uint32    | The ID of the seventh monitor rule associated with the connection event.               |
| Monitor Rule 8                            | uint32    | The ID of the eighth monitor rule associated with the connection event.                |
| Security Intelligence Source/ Destination | uint8     | Whether the source or destination IP address matched the IP blacklist.                 |
| Security Intelligence Layer               | uint8     | The IP layer that matched the IP blacklist.                                            |
| File Event Count                          | uint16    | Value used to distinguish between file events that happen during the same second.      |
| Intrusion Event Count                     | uint16    | Value used to distinguish between intrusion events that happen during the same second. |

## Connection Statistics Data Block 5.3

The connection statistics data block is used in connection data messages. Changes to the connection data block between versions 5.2.x and 5.3 include the addition of new fields for NetFlow information. The connection statistics data block for version 5.3 has a block type of 152 in the series 1 group of blocks. It deprecates block type 144, [Connection Statistics Data Block 5.2.x, page B-89](#).

You request connection event records by setting the extended event flag—bit 30 in the Request Flags field—in the request message with an event version of 10 and an event code of 71. See [Request Flags, page 2-11](#). If you enable bit 23, an extended event header is included in the record.

For more information on the Connection Statistics Data message, see [Connection Statistics Data Message, page 4-46](#).

The following diagram shows the format of a Connection Statistics data block for 5.3+:

::

| Byte                             | 0 |   |   |   |   |   |   |   | 1 |   |    |    |    |    |    |    | 2  |    |    |    |    |    |    |    | 3  |    |    |    |    |    |    |    |
|----------------------------------|---|---|---|---|---|---|---|---|---|---|----|----|----|----|----|----|----|----|----|----|----|----|----|----|----|----|----|----|----|----|----|----|
| Bit                              | 0 | 1 | 2 | 3 | 4 | 5 | 6 | 7 | 8 | 9 | 10 | 11 | 12 | 13 | 14 | 15 | 16 | 17 | 18 | 19 | 20 | 21 | 22 | 23 | 24 | 25 | 26 | 27 | 28 | 29 | 30 | 31 |
| Connection Data Block Type (152) |   |   |   |   |   |   |   |   |   |   |    |    |    |    |    |    |    |    |    |    |    |    |    |    |    |    |    |    |    |    |    |    |
| Connection Data Block Length     |   |   |   |   |   |   |   |   |   |   |    |    |    |    |    |    |    |    |    |    |    |    |    |    |    |    |    |    |    |    |    |    |
| Device ID                        |   |   |   |   |   |   |   |   |   |   |    |    |    |    |    |    |    |    |    |    |    |    |    |    |    |    |    |    |    |    |    |    |
| Ingress Zone                     |   |   |   |   |   |   |   |   |   |   |    |    |    |    |    |    |    |    |    |    |    |    |    |    |    |    |    |    |    |    |    |    |
| Ingress Zone, continued          |   |   |   |   |   |   |   |   |   |   |    |    |    |    |    |    |    |    |    |    |    |    |    |    |    |    |    |    |    |    |    |    |
| Ingress Zone, continued          |   |   |   |   |   |   |   |   |   |   |    |    |    |    |    |    |    |    |    |    |    |    |    |    |    |    |    |    |    |    |    |    |
| Ingress Zone, continued          |   |   |   |   |   |   |   |   |   |   |    |    |    |    |    |    |    |    |    |    |    |    |    |    |    |    |    |    |    |    |    |    |
| Egress Zone                      |   |   |   |   |   |   |   |   |   |   |    |    |    |    |    |    |    |    |    |    |    |    |    |    |    |    |    |    |    |    |    |    |
| Egress Zone, continued           |   |   |   |   |   |   |   |   |   |   |    |    |    |    |    |    |    |    |    |    |    |    |    |    |    |    |    |    |    |    |    |    |
| Egress Zone, continued           |   |   |   |   |   |   |   |   |   |   |    |    |    |    |    |    |    |    |    |    |    |    |    |    |    |    |    |    |    |    |    |    |
| Egress Zone, continued           |   |   |   |   |   |   |   |   |   |   |    |    |    |    |    |    |    |    |    |    |    |    |    |    |    |    |    |    |    |    |    |    |
| Ingress Interface                |   |   |   |   |   |   |   |   |   |   |    |    |    |    |    |    |    |    |    |    |    |    |    |    |    |    |    |    |    |    |    |    |
| Ingress Interface, continued     |   |   |   |   |   |   |   |   |   |   |    |    |    |    |    |    |    |    |    |    |    |    |    |    |    |    |    |    |    |    |    |    |
| Ingress Interface, continued     |   |   |   |   |   |   |   |   |   |   |    |    |    |    |    |    |    |    |    |    |    |    |    |    |    |    |    |    |    |    |    |    |
| Ingress Interface, continued     |   |   |   |   |   |   |   |   |   |   |    |    |    |    |    |    |    |    |    |    |    |    |    |    |    |    |    |    |    |    |    |    |
| Egress Interface                 |   |   |   |   |   |   |   |   |   |   |    |    |    |    |    |    |    |    |    |    |    |    |    |    |    |    |    |    |    |    |    |    |
| Egress Interface, continued      |   |   |   |   |   |   |   |   |   |   |    |    |    |    |    |    |    |    |    |    |    |    |    |    |    |    |    |    |    |    |    |    |
| Egress Interface, continued      |   |   |   |   |   |   |   |   |   |   |    |    |    |    |    |    |    |    |    |    |    |    |    |    |    |    |    |    |    |    |    |    |
| Egress Interface, continued      |   |   |   |   |   |   |   |   |   |   |    |    |    |    |    |    |    |    |    |    |    |    |    |    |    |    |    |    |    |    |    |    |
| Initiator IP Address             |   |   |   |   |   |   |   |   |   |   |    |    |    |    |    |    |    |    |    |    |    |    |    |    |    |    |    |    |    |    |    |    |
| Initiator IP Address, continued  |   |   |   |   |   |   |   |   |   |   |    |    |    |    |    |    |    |    |    |    |    |    |    |    |    |    |    |    |    |    |    |    |
| Initiator IP Address, continued  |   |   |   |   |   |   |   |   |   |   |    |    |    |    |    |    |    |    |    |    |    |    |    |    |    |    |    |    |    |    |    |    |
| Initiator IP Address, continued  |   |   |   |   |   |   |   |   |   |   |    |    |    |    |    |    |    |    |    |    |    |    |    |    |    |    |    |    |    |    |    |    |
| Responder IP Address             |   |   |   |   |   |   |   |   |   |   |    |    |    |    |    |    |    |    |    |    |    |    |    |    |    |    |    |    |    |    |    |    |
| Responder IP Address, continued  |   |   |   |   |   |   |   |   |   |   |    |    |    |    |    |    |    |    |    |    |    |    |    |    |    |    |    |    |    |    |    |    |

|      |                                          |   |   |   |   |   |   |   |                    |   |    |    |    |    |    |    |                |    |    |    |    |    |    |    |                      |    |    |    |    |    |    |    |
|------|------------------------------------------|---|---|---|---|---|---|---|--------------------|---|----|----|----|----|----|----|----------------|----|----|----|----|----|----|----|----------------------|----|----|----|----|----|----|----|
| Byte | 0                                        |   |   |   |   |   |   |   | 1                  |   |    |    |    |    |    |    | 2              |    |    |    |    |    |    |    | 3                    |    |    |    |    |    |    |    |
| Bit  | 0                                        | 1 | 2 | 3 | 4 | 5 | 6 | 7 | 8                  | 9 | 10 | 11 | 12 | 13 | 14 | 15 | 16             | 17 | 18 | 19 | 20 | 21 | 22 | 23 | 24                   | 25 | 26 | 27 | 28 | 29 | 30 | 31 |
|      | Responder IP Address, continued          |   |   |   |   |   |   |   |                    |   |    |    |    |    |    |    |                |    |    |    |    |    |    |    |                      |    |    |    |    |    |    |    |
|      | Responder IP Address, continued          |   |   |   |   |   |   |   |                    |   |    |    |    |    |    |    |                |    |    |    |    |    |    |    |                      |    |    |    |    |    |    |    |
|      | Policy Revision                          |   |   |   |   |   |   |   |                    |   |    |    |    |    |    |    |                |    |    |    |    |    |    |    |                      |    |    |    |    |    |    |    |
|      | Policy Revision, continued               |   |   |   |   |   |   |   |                    |   |    |    |    |    |    |    |                |    |    |    |    |    |    |    |                      |    |    |    |    |    |    |    |
|      | Policy Revision, continued               |   |   |   |   |   |   |   |                    |   |    |    |    |    |    |    |                |    |    |    |    |    |    |    |                      |    |    |    |    |    |    |    |
|      | Policy Revision, continued               |   |   |   |   |   |   |   |                    |   |    |    |    |    |    |    |                |    |    |    |    |    |    |    |                      |    |    |    |    |    |    |    |
|      | Rule ID                                  |   |   |   |   |   |   |   |                    |   |    |    |    |    |    |    |                |    |    |    |    |    |    |    |                      |    |    |    |    |    |    |    |
|      | Rule Action                              |   |   |   |   |   |   |   |                    |   |    |    |    |    |    |    | Rule Reason    |    |    |    |    |    |    |    |                      |    |    |    |    |    |    |    |
|      | Initiator Port                           |   |   |   |   |   |   |   |                    |   |    |    |    |    |    |    | Responder Port |    |    |    |    |    |    |    |                      |    |    |    |    |    |    |    |
|      | TCP Flags                                |   |   |   |   |   |   |   |                    |   |    |    |    |    |    |    | Protocol       |    |    |    |    |    |    |    | NetFlow Source       |    |    |    |    |    |    |    |
|      | NetFlow Source, continued                |   |   |   |   |   |   |   |                    |   |    |    |    |    |    |    |                |    |    |    |    |    |    |    |                      |    |    |    |    |    |    |    |
|      | NetFlow Source, continued                |   |   |   |   |   |   |   |                    |   |    |    |    |    |    |    |                |    |    |    |    |    |    |    |                      |    |    |    |    |    |    |    |
|      | NetFlow Source, continued                |   |   |   |   |   |   |   |                    |   |    |    |    |    |    |    |                |    |    |    |    |    |    |    |                      |    |    |    |    |    |    |    |
|      | NetFlow Source, continued                |   |   |   |   |   |   |   |                    |   |    |    |    |    |    |    |                |    |    |    |    |    |    |    | Instance ID          |    |    |    |    |    |    |    |
|      | Instance ID, cont.                       |   |   |   |   |   |   |   | Connection Counter |   |    |    |    |    |    |    |                |    |    |    |    |    |    |    | First Pkt Time       |    |    |    |    |    |    |    |
|      | First Packet Timestamp, continued        |   |   |   |   |   |   |   |                    |   |    |    |    |    |    |    |                |    |    |    |    |    |    |    | Last Pkt Time        |    |    |    |    |    |    |    |
|      | Last Packet Timestamp, continued         |   |   |   |   |   |   |   |                    |   |    |    |    |    |    |    |                |    |    |    |    |    |    |    | Initiator Tx Packets |    |    |    |    |    |    |    |
|      | Initiator Transmitted Packets, continued |   |   |   |   |   |   |   |                    |   |    |    |    |    |    |    |                |    |    |    |    |    |    |    |                      |    |    |    |    |    |    |    |
|      | Initiator Transmitted Packets, continued |   |   |   |   |   |   |   |                    |   |    |    |    |    |    |    |                |    |    |    |    |    |    |    | Resp. Tx Packets     |    |    |    |    |    |    |    |
|      | Responder Transmitted Packets, continued |   |   |   |   |   |   |   |                    |   |    |    |    |    |    |    |                |    |    |    |    |    |    |    |                      |    |    |    |    |    |    |    |
|      | Responder Transmitted Packets, continued |   |   |   |   |   |   |   |                    |   |    |    |    |    |    |    |                |    |    |    |    |    |    |    | Initiator Tx Bytes   |    |    |    |    |    |    |    |
|      | Initiator Transmitted Bytes, continued   |   |   |   |   |   |   |   |                    |   |    |    |    |    |    |    |                |    |    |    |    |    |    |    |                      |    |    |    |    |    |    |    |
|      | Initiator Transmitted Bytes, continued   |   |   |   |   |   |   |   |                    |   |    |    |    |    |    |    |                |    |    |    |    |    |    |    | Resp. Tx Bytes       |    |    |    |    |    |    |    |
|      | Responder Transmitted Bytes, continued   |   |   |   |   |   |   |   |                    |   |    |    |    |    |    |    |                |    |    |    |    |    |    |    |                      |    |    |    |    |    |    |    |
|      | Responder Transmitted Bytes, continued   |   |   |   |   |   |   |   |                    |   |    |    |    |    |    |    |                |    |    |    |    |    |    |    | User ID              |    |    |    |    |    |    |    |



| Byte               | 0                                  |   |   |   |   |   |   |   | 1               |   |    |    |    |    |    |    | 2                    |    |    |    |    |    |    |    | 3  |    |    |    |    |    |    |    |
|--------------------|------------------------------------|---|---|---|---|---|---|---|-----------------|---|----|----|----|----|----|----|----------------------|----|----|----|----|----|----|----|----|----|----|----|----|----|----|----|
| Bit                | 0                                  | 1 | 2 | 3 | 4 | 5 | 6 | 7 | 8               | 9 | 10 | 11 | 12 | 13 | 14 | 15 | 16                   | 17 | 18 | 19 | 20 | 21 | 22 | 23 | 24 | 25 | 26 | 27 | 28 | 29 | 30 | 31 |
|                    | User ID, continued                 |   |   |   |   |   |   |   |                 |   |    |    |    |    |    |    | Application Prot. ID |    |    |    |    |    |    |    |    |    |    |    |    |    |    |    |
|                    | Application Protocol ID, continued |   |   |   |   |   |   |   |                 |   |    |    |    |    |    |    | URL Category         |    |    |    |    |    |    |    |    |    |    |    |    |    |    |    |
|                    | URL Category, continued            |   |   |   |   |   |   |   |                 |   |    |    |    |    |    |    | URL Reputation       |    |    |    |    |    |    |    |    |    |    |    |    |    |    |    |
|                    | URL Reputation, continued          |   |   |   |   |   |   |   |                 |   |    |    |    |    |    |    | Client App ID        |    |    |    |    |    |    |    |    |    |    |    |    |    |    |    |
|                    | Client Application ID, continued   |   |   |   |   |   |   |   |                 |   |    |    |    |    |    |    | Web App ID           |    |    |    |    |    |    |    |    |    |    |    |    |    |    |    |
| Client URL         | Web Application ID, continued      |   |   |   |   |   |   |   |                 |   |    |    |    |    |    |    | Str. Block Type (0)  |    |    |    |    |    |    |    |    |    |    |    |    |    |    |    |
|                    | String Block Type, continued       |   |   |   |   |   |   |   |                 |   |    |    |    |    |    |    | String Block Length  |    |    |    |    |    |    |    |    |    |    |    |    |    |    |    |
|                    | String Block Length, continued     |   |   |   |   |   |   |   |                 |   |    |    |    |    |    |    | Client App. URL...   |    |    |    |    |    |    |    |    |    |    |    |    |    |    |    |
| NetBIOS Name       | String Block Type (0)              |   |   |   |   |   |   |   |                 |   |    |    |    |    |    |    |                      |    |    |    |    |    |    |    |    |    |    |    |    |    |    |    |
|                    | String Block Length                |   |   |   |   |   |   |   |                 |   |    |    |    |    |    |    |                      |    |    |    |    |    |    |    |    |    |    |    |    |    |    |    |
|                    | NetBIOS Name...                    |   |   |   |   |   |   |   |                 |   |    |    |    |    |    |    |                      |    |    |    |    |    |    |    |    |    |    |    |    |    |    |    |
| Client App Version | String Block Type (0)              |   |   |   |   |   |   |   |                 |   |    |    |    |    |    |    |                      |    |    |    |    |    |    |    |    |    |    |    |    |    |    |    |
|                    | String Block Length                |   |   |   |   |   |   |   |                 |   |    |    |    |    |    |    |                      |    |    |    |    |    |    |    |    |    |    |    |    |    |    |    |
|                    | Client Application Version...      |   |   |   |   |   |   |   |                 |   |    |    |    |    |    |    |                      |    |    |    |    |    |    |    |    |    |    |    |    |    |    |    |
|                    | Monitor Rule 1                     |   |   |   |   |   |   |   |                 |   |    |    |    |    |    |    |                      |    |    |    |    |    |    |    |    |    |    |    |    |    |    |    |
|                    | Monitor Rule 2                     |   |   |   |   |   |   |   |                 |   |    |    |    |    |    |    |                      |    |    |    |    |    |    |    |    |    |    |    |    |    |    |    |
|                    | Monitor Rule 3                     |   |   |   |   |   |   |   |                 |   |    |    |    |    |    |    |                      |    |    |    |    |    |    |    |    |    |    |    |    |    |    |    |
|                    | Monitor Rule 4                     |   |   |   |   |   |   |   |                 |   |    |    |    |    |    |    |                      |    |    |    |    |    |    |    |    |    |    |    |    |    |    |    |
|                    | Monitor Rule 5                     |   |   |   |   |   |   |   |                 |   |    |    |    |    |    |    |                      |    |    |    |    |    |    |    |    |    |    |    |    |    |    |    |
|                    | Monitor Rule 6                     |   |   |   |   |   |   |   |                 |   |    |    |    |    |    |    |                      |    |    |    |    |    |    |    |    |    |    |    |    |    |    |    |
|                    | Monitor Rule 7                     |   |   |   |   |   |   |   |                 |   |    |    |    |    |    |    |                      |    |    |    |    |    |    |    |    |    |    |    |    |    |    |    |
|                    | Monitor Rule 8                     |   |   |   |   |   |   |   |                 |   |    |    |    |    |    |    |                      |    |    |    |    |    |    |    |    |    |    |    |    |    |    |    |
|                    | Sec. Int. Src/Dst                  |   |   |   |   |   |   |   | Sec. Int. Layer |   |    |    |    |    |    |    | File Event Count     |    |    |    |    |    |    |    |    |    |    |    |    |    |    |    |
|                    | Intrusion Event Count              |   |   |   |   |   |   |   |                 |   |    |    |    |    |    |    | Initiator Country    |    |    |    |    |    |    |    |    |    |    |    |    |    |    |    |
|                    | Responder Country                  |   |   |   |   |   |   |   |                 |   |    |    |    |    |    |    | IOC Number           |    |    |    |    |    |    |    |    |    |    |    |    |    |    |    |

|      |                               |   |   |   |   |   |   |   |                 |   |    |    |    |    |    |    |             |    |    |    |    |    |    |    |                  |    |    |    |    |    |    |    |
|------|-------------------------------|---|---|---|---|---|---|---|-----------------|---|----|----|----|----|----|----|-------------|----|----|----|----|----|----|----|------------------|----|----|----|----|----|----|----|
| Byte | 0                             |   |   |   |   |   |   |   | 1               |   |    |    |    |    |    |    | 2           |    |    |    |    |    |    |    | 3                |    |    |    |    |    |    |    |
| Bit  | 0                             | 1 | 2 | 3 | 4 | 5 | 6 | 7 | 8               | 9 | 10 | 11 | 12 | 13 | 14 | 15 | 16          | 17 | 18 | 19 | 20 | 21 | 22 | 23 | 24               | 25 | 26 | 27 | 28 | 29 | 30 | 31 |
|      | Source Autonomous System      |   |   |   |   |   |   |   |                 |   |    |    |    |    |    |    |             |    |    |    |    |    |    |    |                  |    |    |    |    |    |    |    |
|      | Destination Autonomous System |   |   |   |   |   |   |   |                 |   |    |    |    |    |    |    |             |    |    |    |    |    |    |    |                  |    |    |    |    |    |    |    |
|      | SNMP In                       |   |   |   |   |   |   |   |                 |   |    |    |    |    |    |    | SNMP Out    |    |    |    |    |    |    |    |                  |    |    |    |    |    |    |    |
|      | Source TOS                    |   |   |   |   |   |   |   | Destination TOS |   |    |    |    |    |    |    | Source Mask |    |    |    |    |    |    |    | Destination Mask |    |    |    |    |    |    |    |

The following table describes the fields of the Connection Statistics data block for 5.3.

Table B-24 Connection Statistics Data Block 5.3+ Fields

| Field                                   | Data Type | Description                                                                                                                                                                                              |
|-----------------------------------------|-----------|----------------------------------------------------------------------------------------------------------------------------------------------------------------------------------------------------------|
| Connection Statistics Data Block Type   | uint32    | Initiates a Connection Statistics data block for 5.3. The value is always 152.                                                                                                                           |
| Connection Statistics Data Block Length | uint32    | Number of bytes in the Connection Statistics data block, including eight bytes for the connection statistics block type and length fields, plus the number of bytes in the connection data that follows. |
| Device ID                               | uint32    | The device that detected the connection event.                                                                                                                                                           |
| Ingress Zone                            | uint8[16] | Ingress security zone in the event that triggered the policy violation.                                                                                                                                  |
| Egress Zone                             | uint8[16] | Egress security zone in the event that triggered the policy violation.                                                                                                                                   |
| Ingress Interface                       | uint8[16] | Interface for the inbound traffic.                                                                                                                                                                       |
| Egress Interface                        | uint8[16] | Interface for the outbound traffic.                                                                                                                                                                      |
| Initiator IP Address                    | uint8[16] | IP address of the host that initiated the session described in the connection event, in IP address octets.                                                                                               |
| Responder IP Address                    | uint8[16] | IP address of the host that responded to the initiating host, in IP address octets.                                                                                                                      |
| Policy Revision                         | uint8[16] | Revision number of the rule associated with the triggered correlation event, if applicable.                                                                                                              |
| Rule ID                                 | uint32    | Internal identifier for the rule that triggered the event, if applicable.                                                                                                                                |
| Rule Action                             | uint16    | The action selected in the user interface for that rule (allow, block, and so forth).                                                                                                                    |
| Rule Reason                             | uint16    | The reason the rule triggered the event.                                                                                                                                                                 |
| Initiator Port                          | uint16    | Port used by the initiating host.                                                                                                                                                                        |
| Responder Port                          | uint16    | Port used by the responding host.                                                                                                                                                                        |
| TCP Flags                               | uint16    | Indicates any TCP flags for the connection event.                                                                                                                                                        |
| Protocol                                | uint8     | The IANA-specified protocol number.                                                                                                                                                                      |

Table B-24 Connection Statistics Data Block 5.3+ Fields (continued)

| Field                         | Data Type | Description                                                                                                                                                                                        |
|-------------------------------|-----------|----------------------------------------------------------------------------------------------------------------------------------------------------------------------------------------------------|
| NetFlow Source                | uint8[16] | IP address of the NetFlow-enabled device that exported the data for the connection.                                                                                                                |
| Instance ID                   | uint16    | Numerical ID of the Snort instance on the managed device that generated the event.                                                                                                                 |
| Connection Counter            | uint16    | Value used to distinguish between connection events that happen during the same second.                                                                                                            |
| First Packet Timestamp        | uint32    | UNIX timestamp of the date and time the first packet was exchanged in the session.                                                                                                                 |
| Last Packet Timestamp         | uint32    | UNIX timestamp of the date and time the last packet was exchanged in the session.                                                                                                                  |
| Initiator Transmitted Packets | uint64    | Number of packets transmitted by the initiating host.                                                                                                                                              |
| Responder Transmitted Packets | uint64    | Number of packets transmitted by the responding host.                                                                                                                                              |
| Initiator Transmitted Bytes   | uint64    | Number of bytes transmitted by the initiating host.                                                                                                                                                |
| Responder Transmitted Bytes   | uint64    | Number of bytes transmitted by the responding host.                                                                                                                                                |
| User ID                       | uint32    | Internal identification number for the user who last logged into the host that generated the traffic.                                                                                              |
| Application Protocol ID       | uint32    | Application ID of the application protocol.                                                                                                                                                        |
| URL Category                  | uint32    | The internal identification number of the URL category.                                                                                                                                            |
| URL Reputation                | uint32    | The internal identification number for the URL reputation.                                                                                                                                         |
| Client Application ID         | uint32    | The internal identification number of the detected client application, if applicable.                                                                                                              |
| Web Application ID            | uint32    | The internal identification number of the detected web application, if applicable.                                                                                                                 |
| String Block Type             | uint32    | Initiates a String data block for the client application URL. This value is always 0.                                                                                                              |
| String Block Length           | uint32    | Number of bytes in the client application URL String data block, including eight bytes for the string block type and length fields, plus the number of bytes in the client application URL string. |
| Client Application URL        | string    | URL the client application accessed, if applicable (/files/index.html, for example).                                                                                                               |
| String Block Type             | uint32    | Initiates a String data block for the host NetBIOS name. This value is always 0.                                                                                                                   |
| String Block Length           | uint32    | Number of bytes in the String data block, including eight bytes for the string block type and length fields, plus the number of bytes in the NetBIOS name string.                                  |

Table B-24 Connection Statistics Data Block 5.3+ Fields (continued)

| Field                                     | Data Type | Description                                                                                                                                                                       |
|-------------------------------------------|-----------|-----------------------------------------------------------------------------------------------------------------------------------------------------------------------------------|
| NetBIOS Name                              | string    | Host NetBIOS name string.                                                                                                                                                         |
| String Block Type                         | uint32    | Initiates a String data block for the client application version. This value is always 0.                                                                                         |
| String Block Length                       | uint32    | Number of bytes in the String data block for the client application version, including eight bytes for the string block type and length, plus the number of bytes in the version. |
| Client Application Version                | string    | Client application version.                                                                                                                                                       |
| Monitor Rule 1                            | uint32    | The ID of the first monitor rule associated with the connection event.                                                                                                            |
| Monitor Rule 2                            | uint32    | The ID of the second monitor rule associated with the connection event.                                                                                                           |
| Monitor Rule 3                            | uint32    | The ID of the third monitor rule associated with the connection event.                                                                                                            |
| Monitor Rule 4                            | uint32    | The ID of the fourth monitor rule associated with the connection event.                                                                                                           |
| Monitor Rule 5                            | uint32    | The ID of the fifth monitor rule associated with the connection event.                                                                                                            |
| Monitor Rule 6                            | uint32    | The ID of the sixth monitor rule associated with the connection event.                                                                                                            |
| Monitor Rule 7                            | uint32    | The ID of the seventh monitor rule associated with the connection event.                                                                                                          |
| Monitor Rule 8                            | uint32    | The ID of the eighth monitor rule associated with the connection event.                                                                                                           |
| Security Intelligence Source/ Destination | uint8     | Whether the source or destination IP address matched the IP blacklist.                                                                                                            |
| Security Intelligence Layer               | uint8     | The IP layer that matched the IP blacklist.                                                                                                                                       |
| File Event Count                          | uint16    | Value used to distinguish between file events that happen during the same second.                                                                                                 |
| Intrusion Event Count                     | uint16    | Value used to distinguish between intrusion events that happen during the same second.                                                                                            |
| Initiator Country                         | uint16    | Code for the country of the initiating host.                                                                                                                                      |
| Responder Country                         | uint 16   | Code for the country of the responding host.                                                                                                                                      |
| IOC Number                                | uint16    | ID Number of the compromise associated with this event.                                                                                                                           |
| Source Autonomous System                  | uint32    | Autonomous system number of the source, either origin or peer.                                                                                                                    |

*Table B-24 Connection Statistics Data Block 5.3+ Fields (continued)*

| Field                         | Data Type | Description                                                         |
|-------------------------------|-----------|---------------------------------------------------------------------|
| Destination Autonomous System | uint32    | Autonomous system number of the destination, either origin or peer. |
| SNMP Input                    | uint16    | SNMP index of the input interface.                                  |
| SNMP Output                   | uint16    | SNMP index of the output interface.                                 |
| Source TOS                    | uint8     | Type of Service byte setting for the incoming interface.            |
| Destination TOS               | uint8     | Type of Service byte setting for the outgoing interface.            |
| Source Mask                   | uint8     | Source address prefix mask.                                         |
| Destination Mask              | uint8     | Destination address prefix mask.                                    |

## Legacy File Event Data Structures

See the following sections for more information:

- [File Event for 5.1.1.x, page B-109](#)
- [File Event for 5.2.x, page B-113](#)
- [File Event for 5.3, page B-117](#)
- [File Event SHA Hash for 5.1.1-5.2.x, page B-123](#)

### File Event for 5.1.1.x

The file event contains information on files that are sent over the network. This includes the connection information, whether the file is malware, and specific information to identify the file. The file event has a block type of 23 in the series 2 group of blocks.

The following graphic shows the structure of the File Event data block.:

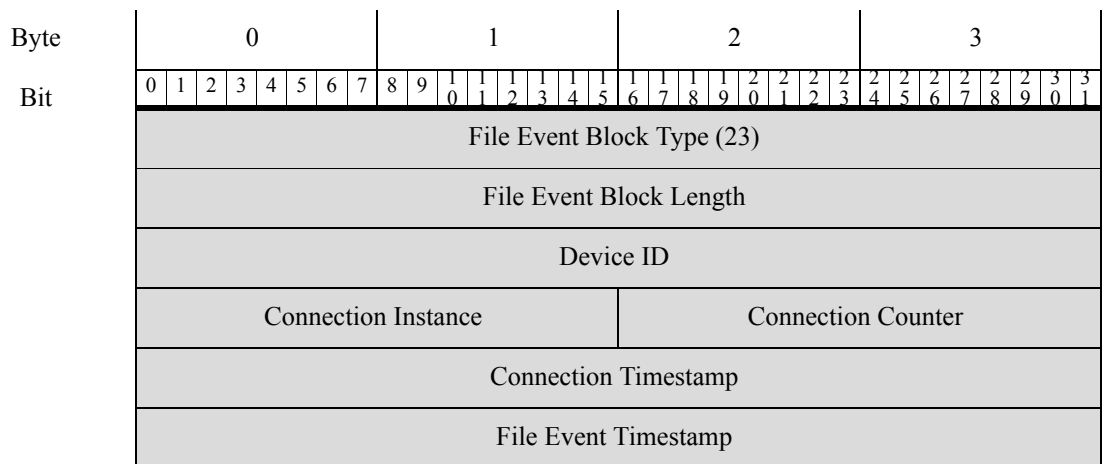

| Byte      | 0                                 |   |   |   |   |   |   |   | 1              |   |   |   |   |   |   |   | 2                     |   |   |   |   |   |   |   | 3 |   |   |   |   |   |   |   |   |   |   |   |   |   |
|-----------|-----------------------------------|---|---|---|---|---|---|---|----------------|---|---|---|---|---|---|---|-----------------------|---|---|---|---|---|---|---|---|---|---|---|---|---|---|---|---|---|---|---|---|---|
| Bit       | 0                                 | 1 | 2 | 3 | 4 | 5 | 6 | 7 | 8              | 9 | 0 | 1 | 2 | 3 | 4 | 5 | 6                     | 7 | 8 | 9 | 0 | 1 | 2 | 3 | 4 | 5 | 6 | 7 | 8 | 9 | 0 | 1 | 2 | 3 | 4 | 5 | 6 | 7 |
|           | Source IP Address                 |   |   |   |   |   |   |   |                |   |   |   |   |   |   |   |                       |   |   |   |   |   |   |   |   |   |   |   |   |   |   |   |   |   |   |   |   |   |
|           | Source IP Address, continued      |   |   |   |   |   |   |   |                |   |   |   |   |   |   |   |                       |   |   |   |   |   |   |   |   |   |   |   |   |   |   |   |   |   |   |   |   |   |
|           | Source IP Address, continued      |   |   |   |   |   |   |   |                |   |   |   |   |   |   |   |                       |   |   |   |   |   |   |   |   |   |   |   |   |   |   |   |   |   |   |   |   |   |
|           | Source IP Address, continued      |   |   |   |   |   |   |   |                |   |   |   |   |   |   |   |                       |   |   |   |   |   |   |   |   |   |   |   |   |   |   |   |   |   |   |   |   |   |
|           | Destination IP Address            |   |   |   |   |   |   |   |                |   |   |   |   |   |   |   |                       |   |   |   |   |   |   |   |   |   |   |   |   |   |   |   |   |   |   |   |   |   |
|           | Destination IP Address, continued |   |   |   |   |   |   |   |                |   |   |   |   |   |   |   |                       |   |   |   |   |   |   |   |   |   |   |   |   |   |   |   |   |   |   |   |   |   |
|           | Destination IP Address, continued |   |   |   |   |   |   |   |                |   |   |   |   |   |   |   |                       |   |   |   |   |   |   |   |   |   |   |   |   |   |   |   |   |   |   |   |   |   |
|           | Destination IP Address, continued |   |   |   |   |   |   |   |                |   |   |   |   |   |   |   |                       |   |   |   |   |   |   |   |   |   |   |   |   |   |   |   |   |   |   |   |   |   |
|           | Disposition                       |   |   |   |   |   |   |   | Action         |   |   |   |   |   |   |   | SHA Hash              |   |   |   |   |   |   |   |   |   |   |   |   |   |   |   |   |   |   |   |   |   |
|           | SHA Hash, continued               |   |   |   |   |   |   |   |                |   |   |   |   |   |   |   |                       |   |   |   |   |   |   |   |   |   |   |   |   |   |   |   |   |   |   |   |   |   |
|           | SHA Hash, continued               |   |   |   |   |   |   |   |                |   |   |   |   |   |   |   |                       |   |   |   |   |   |   |   |   |   |   |   |   |   |   |   |   |   |   |   |   |   |
|           | SHA Hash, continued               |   |   |   |   |   |   |   |                |   |   |   |   |   |   |   |                       |   |   |   |   |   |   |   |   |   |   |   |   |   |   |   |   |   |   |   |   |   |
|           | SHA Hash, continued               |   |   |   |   |   |   |   |                |   |   |   |   |   |   |   |                       |   |   |   |   |   |   |   |   |   |   |   |   |   |   |   |   |   |   |   |   |   |
|           | SHA Hash, continued               |   |   |   |   |   |   |   |                |   |   |   |   |   |   |   |                       |   |   |   |   |   |   |   |   |   |   |   |   |   |   |   |   |   |   |   |   |   |
|           | SHA Hash, continued               |   |   |   |   |   |   |   |                |   |   |   |   |   |   |   |                       |   |   |   |   |   |   |   |   |   |   |   |   |   |   |   |   |   |   |   |   |   |
|           | SHA Hash, continued               |   |   |   |   |   |   |   |                |   |   |   |   |   |   |   |                       |   |   |   |   |   |   |   |   |   |   |   |   |   |   |   |   |   |   |   |   |   |
|           | SHA Hash, continued               |   |   |   |   |   |   |   |                |   |   |   |   |   |   |   | File Type ID          |   |   |   |   |   |   |   |   |   |   |   |   |   |   |   |   |   |   |   |   |   |
| File Name | File Type ID, cont.               |   |   |   |   |   |   |   |                |   |   |   |   |   |   |   | String Block Type (0) |   |   |   |   |   |   |   |   |   |   |   |   |   |   |   |   |   |   |   |   |   |
|           | String Block Type (0), cont.      |   |   |   |   |   |   |   |                |   |   |   |   |   |   |   | String Block Length   |   |   |   |   |   |   |   |   |   |   |   |   |   |   |   |   |   |   |   |   |   |
|           | String Block Length, cont.        |   |   |   |   |   |   |   |                |   |   |   |   |   |   |   | File Name...          |   |   |   |   |   |   |   |   |   |   |   |   |   |   |   |   |   |   |   |   |   |
|           | File Size                         |   |   |   |   |   |   |   |                |   |   |   |   |   |   |   |                       |   |   |   |   |   |   |   |   |   |   |   |   |   |   |   |   |   |   |   |   |   |
|           | File Size, continued              |   |   |   |   |   |   |   |                |   |   |   |   |   |   |   |                       |   |   |   |   |   |   |   |   |   |   |   |   |   |   |   |   |   |   |   |   |   |
|           | Direction                         |   |   |   |   |   |   |   | Application ID |   |   |   |   |   |   |   |                       |   |   |   |   |   |   |   |   |   |   |   |   |   |   |   |   |   |   |   |   |   |
|           | App ID, cont.                     |   |   |   |   |   |   |   | User ID        |   |   |   |   |   |   |   |                       |   |   |   |   |   |   |   |   |   |   |   |   |   |   |   |   |   |   |   |   |   |

| Byte               | 0                            |   |   |   |   |   |   |                                       | 1                     |   |   |                  |   |   |   |   | 2 |   |   |   |   |   |   |   | 3 |   |   |   |   |   |   |   |
|--------------------|------------------------------|---|---|---|---|---|---|---------------------------------------|-----------------------|---|---|------------------|---|---|---|---|---|---|---|---|---|---|---|---|---|---|---|---|---|---|---|---|
| Bit                | 0                            | 1 | 2 | 3 | 4 | 5 | 6 | 7                                     | 8                     | 9 | 0 | 1                | 2 | 3 | 4 | 5 | 6 | 7 | 8 | 9 | 0 | 1 | 2 | 2 | 2 | 2 | 2 | 2 | 2 | 2 | 3 | 3 |
| URI                | User ID, cont.               |   |   |   |   |   |   |                                       | String Block Type (0) |   |   |                  |   |   |   |   |   |   |   |   |   |   |   |   |   |   |   |   |   |   |   |   |
|                    | String Block Type (0), cont. |   |   |   |   |   |   |                                       | String Block Length   |   |   |                  |   |   |   |   |   |   |   |   |   |   |   |   |   |   |   |   |   |   |   |   |
|                    | String Block Length, cont.   |   |   |   |   |   |   |                                       | URI...                |   |   |                  |   |   |   |   |   |   |   |   |   |   |   |   |   |   |   |   |   |   |   |   |
| Signature          | String Block Type (0)        |   |   |   |   |   |   |                                       |                       |   |   |                  |   |   |   |   |   |   |   |   |   |   |   |   |   |   |   |   |   |   |   |   |
|                    | String Block Length          |   |   |   |   |   |   |                                       |                       |   |   |                  |   |   |   |   |   |   |   |   |   |   |   |   |   |   |   |   |   |   |   |   |
|                    | Signature...                 |   |   |   |   |   |   |                                       |                       |   |   |                  |   |   |   |   |   |   |   |   |   |   |   |   |   |   |   |   |   |   |   |   |
| Source Port        |                              |   |   |   |   |   |   |                                       |                       |   |   | Destination Port |   |   |   |   |   |   |   |   |   |   |   |   |   |   |   |   |   |   |   |   |
| Protocol           |                              |   |   |   |   |   |   | Access Control Policy UUID            |                       |   |   |                  |   |   |   |   |   |   |   |   |   |   |   |   |   |   |   |   |   |   |   |   |
| AC Pol UUID, cont. |                              |   |   |   |   |   |   | Access Control Policy UUID, continued |                       |   |   |                  |   |   |   |   |   |   |   |   |   |   |   |   |   |   |   |   |   |   |   |   |
|                    |                              |   |   |   |   |   |   | Access Control Policy UUID, continued |                       |   |   |                  |   |   |   |   |   |   |   |   |   |   |   |   |   |   |   |   |   |   |   |   |
|                    |                              |   |   |   |   |   |   | Access Control Policy UUID, continued |                       |   |   |                  |   |   |   |   |   |   |   |   |   |   |   |   |   |   |   |   |   |   |   |   |

The following table describes the fields in the file event data block:

**Table B-25** File Event Data Block Fields

| Field                   | Data Type | Description                                                                                                                                                          |
|-------------------------|-----------|----------------------------------------------------------------------------------------------------------------------------------------------------------------------|
| File Event Block Type   | uint32    | Initiates whether file event data block. This value is always 23.                                                                                                    |
| File Event Block Length | uint32    | Total number of bytes in the file event block, including eight bytes for the file event block type and length fields, plus the number of bytes of data that follows. |
| Device ID               | uint32    | ID for the device that generated the event.                                                                                                                          |
| Connection Instance     | uint16    | Snort instance on the device that generated the event. Used to link the event with a connection or intrusion event.                                                  |
| Connection Counter      | uint16    | Value used to distinguish between connection events that happen during the same second.                                                                              |
| Connection Timestamp    | uint32    | UNIX timestamp (seconds since 01/01/1970) of the associated connection event.                                                                                        |
| File Event Timestamp    | uint32    | UNIX timestamp (seconds since 01/01/1970) of when the file type is identified and the file event generated.                                                          |

Table B-25 File Event Data Block Fields (continued)

| Field                  | Data Type | Description                                                                                                                                                                                                                                                                                                                                                                                                                                                                                                |
|------------------------|-----------|------------------------------------------------------------------------------------------------------------------------------------------------------------------------------------------------------------------------------------------------------------------------------------------------------------------------------------------------------------------------------------------------------------------------------------------------------------------------------------------------------------|
| Source IP Address      | uint8[16] | IPv4 or IPv6 address for the source of the connection.                                                                                                                                                                                                                                                                                                                                                                                                                                                     |
| Destination IP Address | uint8[16] | IPv4 or IPv6 address for the destination of the connection.                                                                                                                                                                                                                                                                                                                                                                                                                                                |
| Disposition            | uint8     | The malware status of the file. Possible values include: <ul style="list-style-type: none"> <li>• 1 - CLEAN - The file is clean and does not contain malware.</li> <li>• 2 - UNKNOWN - It is unknown whether the file contains malware.</li> <li>• 3 - MALWARE - The file contains malware.</li> <li>• 4 - CACHE_MISS - The software was unable to send a request to the Cisco cloud for a disposition.</li> <li>• 5 - NO_CLOUD_RESP - The Cisco cloud services did not respond to the request.</li> </ul> |
| Action                 | uint8     | The action taken on the file based on the file type. Can have the following values: <ul style="list-style-type: none"> <li>• 1 - Detect</li> <li>• 2 - Block</li> <li>• 3 - Malware Cloud Lookup</li> <li>• 4 - Malware Block</li> <li>• 5 - Malware Whitelist</li> </ul>                                                                                                                                                                                                                                  |
| SHA Hash               | uint8[32] | SHA-256 hash of the file, in binary format.                                                                                                                                                                                                                                                                                                                                                                                                                                                                |
| File Type ID           | uint32    | ID number that maps to the file type.                                                                                                                                                                                                                                                                                                                                                                                                                                                                      |
| File Name              | string    | Name of the file.                                                                                                                                                                                                                                                                                                                                                                                                                                                                                          |
| File Size              | uint64    | Size of the file in bytes.                                                                                                                                                                                                                                                                                                                                                                                                                                                                                 |
| Direction              | uint8     | Value that indicates whether the file was uploaded or downloaded. Can have the following values: <ul style="list-style-type: none"> <li>• 1 - Download</li> <li>• 2 - Upload</li> </ul> <p>Currently the value depends on the protocol (for example, if the connection is HTTP it is a download).</p>                                                                                                                                                                                                      |
| Application ID         | uint32    | ID number that maps to the application using the file transfer.                                                                                                                                                                                                                                                                                                                                                                                                                                            |
| User ID                | uint32    | ID number for the user logged into the destination host, as identified by the system.                                                                                                                                                                                                                                                                                                                                                                                                                      |
| URI                    | string    | Uniform Resource Identifier (URI) of the connection.                                                                                                                                                                                                                                                                                                                                                                                                                                                       |
| Signature              | string    | SHA-256 hash of the file, in string format.                                                                                                                                                                                                                                                                                                                                                                                                                                                                |
| Source Port            | uint16    | Port number for the source of the connection.                                                                                                                                                                                                                                                                                                                                                                                                                                                              |
| Destination Port       | uint16    | Port number for the destination of the connection.                                                                                                                                                                                                                                                                                                                                                                                                                                                         |



Table B-25 File Event Data Block Fields (continued)

| Field                      | Data Type | Description                                                                                                                                                                                                |
|----------------------------|-----------|------------------------------------------------------------------------------------------------------------------------------------------------------------------------------------------------------------|
| Protocol                   | uint8     | IANA protocol number specified by the user. For example: <ul style="list-style-type: none"> <li>• 1 - ICMP</li> <li>• 4 - IP</li> <li>• 6 - TCP</li> <li>• 17 - UDP</li> </ul> This is currently only TCP. |
| Access Control Policy UUID | uint8[16] | Unique identifier for the access control policy that triggered the event.                                                                                                                                  |

## File Event for 5.2.x

The file event contains information on files that are sent over the network. This includes the connection information, whether the file is malware, and specific information to identify the file. The file event has a block type of 32 in the series 2 group of blocks. It supersedes block type 23. New fields have been added to track source and destination country, as well as the client and web application instances.

The following graphic shows the structure of the File Event data block:

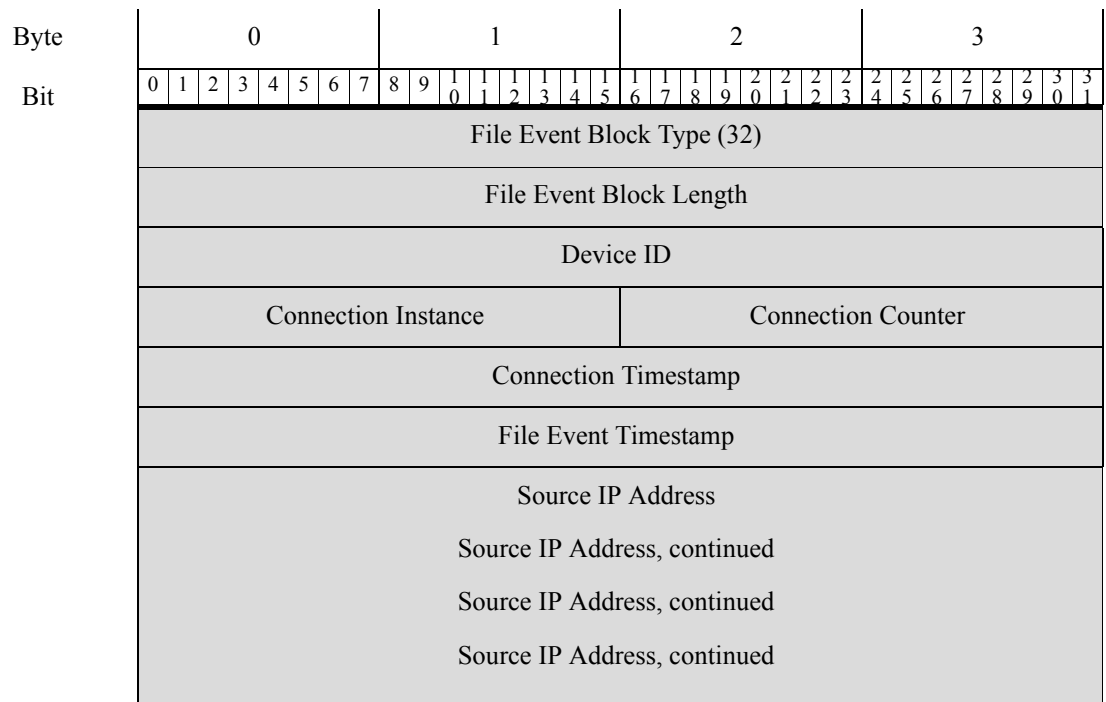

|           |                                   |   |   |   |   |   |   |   |                       |   |   |   |   |   |   |   |                       |   |   |   |   |   |   |   |   |   |   |   |   |   |   |   |   |   |   |   |   |   |
|-----------|-----------------------------------|---|---|---|---|---|---|---|-----------------------|---|---|---|---|---|---|---|-----------------------|---|---|---|---|---|---|---|---|---|---|---|---|---|---|---|---|---|---|---|---|---|
| Byte      | 0                                 |   |   |   |   |   |   |   | 1                     |   |   |   |   |   |   |   | 2                     |   |   |   |   |   |   |   | 3 |   |   |   |   |   |   |   |   |   |   |   |   |   |
| Bit       | 0                                 | 1 | 2 | 3 | 4 | 5 | 6 | 7 | 8                     | 9 | 0 | 1 | 2 | 3 | 4 | 5 | 6                     | 7 | 8 | 9 | 0 | 1 | 2 | 3 | 4 | 5 | 6 | 7 | 8 | 9 | 0 | 1 | 2 | 3 | 4 | 5 | 6 | 7 |
|           | Destination IP Address            |   |   |   |   |   |   |   |                       |   |   |   |   |   |   |   |                       |   |   |   |   |   |   |   |   |   |   |   |   |   |   |   |   |   |   |   |   |   |
|           | Destination IP Address, continued |   |   |   |   |   |   |   |                       |   |   |   |   |   |   |   |                       |   |   |   |   |   |   |   |   |   |   |   |   |   |   |   |   |   |   |   |   |   |
|           | Destination IP Address, continued |   |   |   |   |   |   |   |                       |   |   |   |   |   |   |   |                       |   |   |   |   |   |   |   |   |   |   |   |   |   |   |   |   |   |   |   |   |   |
|           | Destination IP Address, continued |   |   |   |   |   |   |   |                       |   |   |   |   |   |   |   |                       |   |   |   |   |   |   |   |   |   |   |   |   |   |   |   |   |   |   |   |   |   |
|           | Disposition                       |   |   |   |   |   |   |   | Action                |   |   |   |   |   |   |   | SHA Hash              |   |   |   |   |   |   |   |   |   |   |   |   |   |   |   |   |   |   |   |   |   |
|           | SHA Hash, continued               |   |   |   |   |   |   |   |                       |   |   |   |   |   |   |   |                       |   |   |   |   |   |   |   |   |   |   |   |   |   |   |   |   |   |   |   |   |   |
|           | SHA Hash, continued               |   |   |   |   |   |   |   |                       |   |   |   |   |   |   |   |                       |   |   |   |   |   |   |   |   |   |   |   |   |   |   |   |   |   |   |   |   |   |
|           | SHA Hash, continued               |   |   |   |   |   |   |   |                       |   |   |   |   |   |   |   |                       |   |   |   |   |   |   |   |   |   |   |   |   |   |   |   |   |   |   |   |   |   |
|           | SHA Hash, continued               |   |   |   |   |   |   |   |                       |   |   |   |   |   |   |   |                       |   |   |   |   |   |   |   |   |   |   |   |   |   |   |   |   |   |   |   |   |   |
|           | SHA Hash, continued               |   |   |   |   |   |   |   |                       |   |   |   |   |   |   |   |                       |   |   |   |   |   |   |   |   |   |   |   |   |   |   |   |   |   |   |   |   |   |
|           | SHA Hash, continued               |   |   |   |   |   |   |   |                       |   |   |   |   |   |   |   |                       |   |   |   |   |   |   |   |   |   |   |   |   |   |   |   |   |   |   |   |   |   |
|           | SHA Hash, continued               |   |   |   |   |   |   |   |                       |   |   |   |   |   |   |   |                       |   |   |   |   |   |   |   |   |   |   |   |   |   |   |   |   |   |   |   |   |   |
|           | SHA Hash, continued               |   |   |   |   |   |   |   |                       |   |   |   |   |   |   |   | File Type ID          |   |   |   |   |   |   |   |   |   |   |   |   |   |   |   |   |   |   |   |   |   |
| File Name | File Type ID, cont.               |   |   |   |   |   |   |   |                       |   |   |   |   |   |   |   | String Block Type (0) |   |   |   |   |   |   |   |   |   |   |   |   |   |   |   |   |   |   |   |   |   |
|           | String Block Type (0), cont.      |   |   |   |   |   |   |   |                       |   |   |   |   |   |   |   | String Block Length   |   |   |   |   |   |   |   |   |   |   |   |   |   |   |   |   |   |   |   |   |   |
|           | String Block Length, cont.        |   |   |   |   |   |   |   |                       |   |   |   |   |   |   |   | File Name...          |   |   |   |   |   |   |   |   |   |   |   |   |   |   |   |   |   |   |   |   |   |
|           | File Size                         |   |   |   |   |   |   |   |                       |   |   |   |   |   |   |   |                       |   |   |   |   |   |   |   |   |   |   |   |   |   |   |   |   |   |   |   |   |   |
|           | File Size, continued              |   |   |   |   |   |   |   |                       |   |   |   |   |   |   |   |                       |   |   |   |   |   |   |   |   |   |   |   |   |   |   |   |   |   |   |   |   |   |
|           | Direction                         |   |   |   |   |   |   |   | Application ID        |   |   |   |   |   |   |   |                       |   |   |   |   |   |   |   |   |   |   |   |   |   |   |   |   |   |   |   |   |   |
|           | App ID, cont.                     |   |   |   |   |   |   |   | User ID               |   |   |   |   |   |   |   |                       |   |   |   |   |   |   |   |   |   |   |   |   |   |   |   |   |   |   |   |   |   |
| URI       | User ID, cont.                    |   |   |   |   |   |   |   | String Block Type (0) |   |   |   |   |   |   |   |                       |   |   |   |   |   |   |   |   |   |   |   |   |   |   |   |   |   |   |   |   |   |
|           | String Block Type (0), cont.      |   |   |   |   |   |   |   | String Block Length   |   |   |   |   |   |   |   |                       |   |   |   |   |   |   |   |   |   |   |   |   |   |   |   |   |   |   |   |   |   |
|           | String Block Length, cont.        |   |   |   |   |   |   |   | URI...                |   |   |   |   |   |   |   |                       |   |   |   |   |   |   |   |   |   |   |   |   |   |   |   |   |   |   |   |   |   |

| Byte                  | 0                     |   |   |   |   |   |   |                            | 1 |   |   |   |   |   |   |                                       | 2 |   |   |              |   |   |   |   | 3 |   |   |   |   |   |   |   |
|-----------------------|-----------------------|---|---|---|---|---|---|----------------------------|---|---|---|---|---|---|---|---------------------------------------|---|---|---|--------------|---|---|---|---|---|---|---|---|---|---|---|---|
| Bit                   | 0                     | 1 | 2 | 3 | 4 | 5 | 6 | 7                          | 8 | 9 | 0 | 1 | 2 | 3 | 4 | 5                                     | 6 | 7 | 8 | 9            | 0 | 1 | 2 | 2 | 2 | 2 | 2 | 2 | 2 | 2 | 3 | 3 |
| Signature             | String Block Type (0) |   |   |   |   |   |   |                            |   |   |   |   |   |   |   |                                       |   |   |   |              |   |   |   |   |   |   |   |   |   |   |   |   |
|                       | String Block Length   |   |   |   |   |   |   |                            |   |   |   |   |   |   |   |                                       |   |   |   |              |   |   |   |   |   |   |   |   |   |   |   |   |
|                       | Signature...          |   |   |   |   |   |   |                            |   |   |   |   |   |   |   |                                       |   |   |   |              |   |   |   |   |   |   |   |   |   |   |   |   |
| Source Port           |                       |   |   |   |   |   |   |                            |   |   |   |   |   |   |   | Destination Port                      |   |   |   |              |   |   |   |   |   |   |   |   |   |   |   |   |
| Protocol              |                       |   |   |   |   |   |   | Access Control Policy UUID |   |   |   |   |   |   |   |                                       |   |   |   |              |   |   |   |   |   |   |   |   |   |   |   |   |
| AC Pol UUID, cont.    |                       |   |   |   |   |   |   |                            |   |   |   |   |   |   |   | Access Control Policy UUID, continued |   |   |   |              |   |   |   |   |   |   |   |   |   |   |   |   |
|                       |                       |   |   |   |   |   |   |                            |   |   |   |   |   |   |   | Access Control Policy UUID, continued |   |   |   |              |   |   |   |   |   |   |   |   |   |   |   |   |
|                       |                       |   |   |   |   |   |   |                            |   |   |   |   |   |   |   | Access Control Policy UUID, continued |   |   |   |              |   |   |   |   |   |   |   |   |   |   |   |   |
| AC Pol UUID, cont.    |                       |   |   |   |   |   |   | Source Country             |   |   |   |   |   |   |   |                                       |   |   |   | Dst. Country |   |   |   |   |   |   |   |   |   |   |   |   |
| Dst. Country, cont.   |                       |   |   |   |   |   |   | Web Application ID         |   |   |   |   |   |   |   |                                       |   |   |   |              |   |   |   |   |   |   |   |   |   |   |   |   |
| Web App. ID, cont.    |                       |   |   |   |   |   |   | Client Application ID      |   |   |   |   |   |   |   |                                       |   |   |   |              |   |   |   |   |   |   |   |   |   |   |   |   |
| Client App. ID, cont. |                       |   |   |   |   |   |   |                            |   |   |   |   |   |   |   |                                       |   |   |   |              |   |   |   |   |   |   |   |   |   |   |   |   |

The following table describes the fields in the file event data block:

**Table B-26** File Event Data Block Fields

| Field                   | Data Type | Description                                                                                                                                                          |
|-------------------------|-----------|----------------------------------------------------------------------------------------------------------------------------------------------------------------------|
| File Event Block Type   | uint32    | Initiates whether file event data block. This value is always 23.                                                                                                    |
| File Event Block Length | uint32    | Total number of bytes in the file event block, including eight bytes for the file event block type and length fields, plus the number of bytes of data that follows. |
| Device ID               | uint32    | ID for the device that generated the event.                                                                                                                          |
| Connection Instance     | uint16    | Snort instance on the device that generated the event. Used to link the event with a connection or intrusion event.                                                  |
| Connection Counter      | uint16    | Value used to distinguish between connection events that happen during the same second.                                                                              |
| Connection Timestamp    | uint32    | UNIX timestamp (seconds since 01/01/1970) of the associated connection event.                                                                                        |
| File Event Timestamp    | uint32    | UNIX timestamp (seconds since 01/01/1970) of when the file type is identified and the file event generated.                                                          |
| Source IP Address       | uint8[16] | IPv4 or IPv6 address for the source of the connection.                                                                                                               |

Table B-26 File Event Data Block Fields (continued)

| Field                  | Data Type | Description                                                                                                                                                                                                                                                                                                                                                                                                                                                                    |
|------------------------|-----------|--------------------------------------------------------------------------------------------------------------------------------------------------------------------------------------------------------------------------------------------------------------------------------------------------------------------------------------------------------------------------------------------------------------------------------------------------------------------------------|
| Destination IP Address | uint8[16] | IPv4 or IPv6 address for the destination of the connection.                                                                                                                                                                                                                                                                                                                                                                                                                    |
| Disposition            | uint8     | The malware status of the file. Possible values include: <ul style="list-style-type: none"> <li>• 1 - CLEAN - The file is clean and does not contain malware.</li> <li>• 2 - NEUTRAL - It is unknown whether the file contains malware.</li> <li>• 3 - MALWARE - The file contains malware.</li> <li>• 4 - CACHE_MISS - The software was unable to send a request to the Cisco cloud for a disposition, or the Cisco cloud services did not respond to the request.</li> </ul> |
| Action                 | uint8     | The action taken on the file based on the file type. Can have the following values: <ul style="list-style-type: none"> <li>• 1 - Detect</li> <li>• 2 - Block</li> <li>• 3 - Malware Cloud Lookup</li> <li>• 4 - Malware Block</li> <li>• 5 - Malware Whitelist</li> </ul>                                                                                                                                                                                                      |
| SHA Hash               | uint8[32] | SHA-256 hash of the file, in binary format.                                                                                                                                                                                                                                                                                                                                                                                                                                    |
| File Type ID           | uint32    | ID number that maps to the file type.                                                                                                                                                                                                                                                                                                                                                                                                                                          |
| File Name              | string    | Name of the file.                                                                                                                                                                                                                                                                                                                                                                                                                                                              |
| File Size              | uint64    | Size of the file in bytes.                                                                                                                                                                                                                                                                                                                                                                                                                                                     |
| Direction              | uint8     | Value that indicates whether the file was uploaded or downloaded. Can have the following values: <ul style="list-style-type: none"> <li>• 1 - Download</li> <li>• 2 - Upload</li> </ul> <p>Currently the value depends on the protocol (for example, if the connection is HTTP it is a download).</p>                                                                                                                                                                          |
| Application ID         | uint32    | ID number that maps to the application using the file transfer.                                                                                                                                                                                                                                                                                                                                                                                                                |
| User ID                | uint32    | ID number for the user logged into the destination host, as identified by the system.                                                                                                                                                                                                                                                                                                                                                                                          |
| URI                    | string    | Uniform Resource Identifier (URI) of the connection.                                                                                                                                                                                                                                                                                                                                                                                                                           |
| Signature              | string    | SHA-256 hash of the file, in string format.                                                                                                                                                                                                                                                                                                                                                                                                                                    |
| Source Port            | uint16    | Port number for the source of the connection.                                                                                                                                                                                                                                                                                                                                                                                                                                  |
| Destination Port       | uint16    | Port number for the destination of the connection.                                                                                                                                                                                                                                                                                                                                                                                                                             |

Table B-26 File Event Data Block Fields (continued)

| Field                      | Data Type | Description                                                                                                                                                                                                |
|----------------------------|-----------|------------------------------------------------------------------------------------------------------------------------------------------------------------------------------------------------------------|
| Protocol                   | uint8     | IANA protocol number specified by the user. For example: <ul style="list-style-type: none"> <li>• 1 - ICMP</li> <li>• 4 - IP</li> <li>• 6 - TCP</li> <li>• 17 - UDP</li> </ul> This is currently only TCP. |
| Access Control Policy UUID | uint8[16] | Unique identifier for the access control policy that triggered the event.                                                                                                                                  |
| Source Country             | uint16    | Code for the country of the source host.                                                                                                                                                                   |
| Destination Country        | uint16    | Code for the country of the destination host.                                                                                                                                                              |
| Web Application ID         | uint32    | The internal identification number for the web application, if applicable.                                                                                                                                 |
| Client Application ID      | uint32    | The internal identification number for the client application, if applicable.                                                                                                                              |

## File Event for 5.3

The file event contains information on files that are sent over the network. This includes the connection information, whether the file is malware, and specific information to identify the file. The file event has a block type of 38 in the series 2 group of blocks. It supersedes block type 32. New fields have been added to track dynamic file analysis and file storage.

You request file event records by setting the file event flag—bit 30 in the Request Flags field—in the request message with an event version of 3 and an event code of 111. See [Request Flags, page 2-11](#). If you enable bit 23, an extended event header is included in the record.

The following graphic shows the structure of the File Event data block.

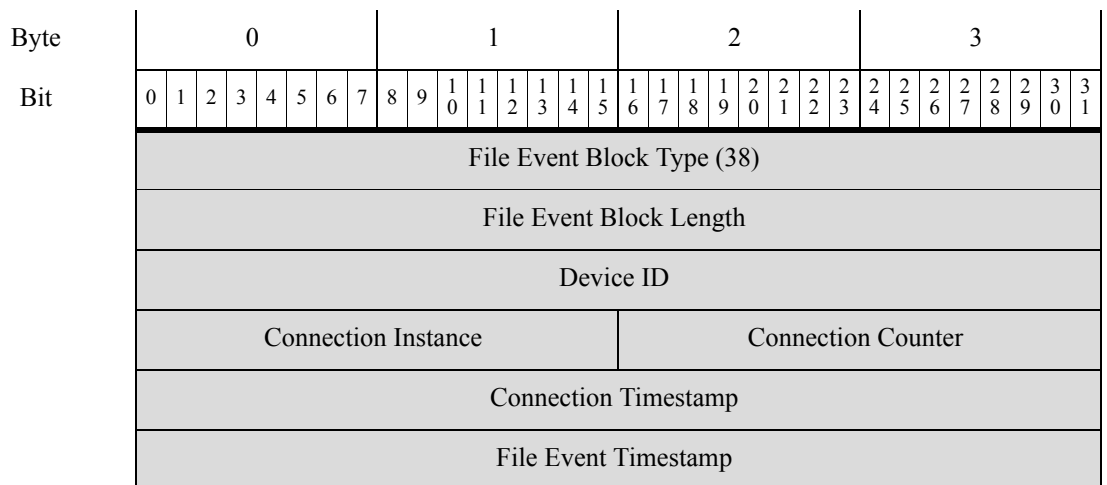

| Byte      | 0                                 |   |   |   |   |   |   |   | 1                 |   |    |    |    |    |    |    | 2                   |    |    |    |    |    |    |    | 3                     |    |    |    |    |    |    |    |
|-----------|-----------------------------------|---|---|---|---|---|---|---|-------------------|---|----|----|----|----|----|----|---------------------|----|----|----|----|----|----|----|-----------------------|----|----|----|----|----|----|----|
|           | 0                                 | 1 | 2 | 3 | 4 | 5 | 6 | 7 | 8                 | 9 | 10 | 11 | 12 | 13 | 14 | 15 | 16                  | 17 | 18 | 19 | 20 | 21 | 22 | 23 | 24                    | 25 | 26 | 27 | 28 | 29 | 30 | 31 |
|           | Source IP Address                 |   |   |   |   |   |   |   |                   |   |    |    |    |    |    |    |                     |    |    |    |    |    |    |    |                       |    |    |    |    |    |    |    |
|           | Source IP Address, continued      |   |   |   |   |   |   |   |                   |   |    |    |    |    |    |    |                     |    |    |    |    |    |    |    |                       |    |    |    |    |    |    |    |
|           | Source IP Address, continued      |   |   |   |   |   |   |   |                   |   |    |    |    |    |    |    |                     |    |    |    |    |    |    |    |                       |    |    |    |    |    |    |    |
|           | Source IP Address, continued      |   |   |   |   |   |   |   |                   |   |    |    |    |    |    |    |                     |    |    |    |    |    |    |    |                       |    |    |    |    |    |    |    |
|           | Destination IP Address            |   |   |   |   |   |   |   |                   |   |    |    |    |    |    |    |                     |    |    |    |    |    |    |    |                       |    |    |    |    |    |    |    |
|           | Destination IP Address, continued |   |   |   |   |   |   |   |                   |   |    |    |    |    |    |    |                     |    |    |    |    |    |    |    |                       |    |    |    |    |    |    |    |
|           | Destination IP Address, continued |   |   |   |   |   |   |   |                   |   |    |    |    |    |    |    |                     |    |    |    |    |    |    |    |                       |    |    |    |    |    |    |    |
|           | Destination IP Address, continued |   |   |   |   |   |   |   |                   |   |    |    |    |    |    |    |                     |    |    |    |    |    |    |    |                       |    |    |    |    |    |    |    |
|           | Disposition                       |   |   |   |   |   |   |   | SPERO Disposition |   |    |    |    |    |    |    | File Storage Status |    |    |    |    |    |    |    | File Analysis Status  |    |    |    |    |    |    |    |
|           | Archive File Status               |   |   |   |   |   |   |   | Threat Score      |   |    |    |    |    |    |    | Action              |    |    |    |    |    |    |    | SHA Hash              |    |    |    |    |    |    |    |
|           | SHA Hash, continued               |   |   |   |   |   |   |   |                   |   |    |    |    |    |    |    |                     |    |    |    |    |    |    |    |                       |    |    |    |    |    |    |    |
|           | SHA Hash, continued               |   |   |   |   |   |   |   |                   |   |    |    |    |    |    |    |                     |    |    |    |    |    |    |    |                       |    |    |    |    |    |    |    |
|           | SHA Hash, continued               |   |   |   |   |   |   |   |                   |   |    |    |    |    |    |    |                     |    |    |    |    |    |    |    |                       |    |    |    |    |    |    |    |
|           | SHA Hash, continued               |   |   |   |   |   |   |   |                   |   |    |    |    |    |    |    |                     |    |    |    |    |    |    |    |                       |    |    |    |    |    |    |    |
|           | SHA Hash, continued               |   |   |   |   |   |   |   |                   |   |    |    |    |    |    |    |                     |    |    |    |    |    |    |    |                       |    |    |    |    |    |    |    |
|           | SHA Hash, continued               |   |   |   |   |   |   |   |                   |   |    |    |    |    |    |    |                     |    |    |    |    |    |    |    |                       |    |    |    |    |    |    |    |
|           | SHA Hash, continued               |   |   |   |   |   |   |   |                   |   |    |    |    |    |    |    |                     |    |    |    |    |    |    |    |                       |    |    |    |    |    |    |    |
|           | SHA Hash, continued               |   |   |   |   |   |   |   |                   |   |    |    |    |    |    |    |                     |    |    |    |    |    |    |    | File Type ID          |    |    |    |    |    |    |    |
| File Name | File Type ID, cont.               |   |   |   |   |   |   |   |                   |   |    |    |    |    |    |    |                     |    |    |    |    |    |    |    | String Block Type (0) |    |    |    |    |    |    |    |
|           | String Block Type (0), cont.      |   |   |   |   |   |   |   |                   |   |    |    |    |    |    |    |                     |    |    |    |    |    |    |    | String Block Length   |    |    |    |    |    |    |    |
|           | String Block Length, cont.        |   |   |   |   |   |   |   |                   |   |    |    |    |    |    |    |                     |    |    |    |    |    |    |    | File Name...          |    |    |    |    |    |    |    |
|           | File Size                         |   |   |   |   |   |   |   |                   |   |    |    |    |    |    |    |                     |    |    |    |    |    |    |    |                       |    |    |    |    |    |    |    |
|           | File Size, continued              |   |   |   |   |   |   |   |                   |   |    |    |    |    |    |    |                     |    |    |    |    |    |    |    |                       |    |    |    |    |    |    |    |
|           | Direction                         |   |   |   |   |   |   |   | Application ID    |   |    |    |    |    |    |    |                     |    |    |    |    |    |    |    |                       |    |    |    |    |    |    |    |
|           | App ID, cont.                     |   |   |   |   |   |   |   | User ID           |   |    |    |    |    |    |    |                     |    |    |    |    |    |    |    |                       |    |    |    |    |    |    |    |

| Byte                  | 0                            |   |   |   |   |   |   |                                       | 1                     |   |    |    |    |    |    |                  | 2  |    |    |    |    |    |    |              | 3  |    |    |    |    |    |    |    |
|-----------------------|------------------------------|---|---|---|---|---|---|---------------------------------------|-----------------------|---|----|----|----|----|----|------------------|----|----|----|----|----|----|----|--------------|----|----|----|----|----|----|----|----|
| Bit                   | 0                            | 1 | 2 | 3 | 4 | 5 | 6 | 7                                     | 8                     | 9 | 10 | 11 | 12 | 13 | 14 | 15               | 16 | 17 | 18 | 19 | 20 | 21 | 22 | 23           | 24 | 25 | 26 | 27 | 28 | 29 | 30 | 31 |
| URI                   | User ID, cont.               |   |   |   |   |   |   |                                       | String Block Type (0) |   |    |    |    |    |    |                  |    |    |    |    |    |    |    |              |    |    |    |    |    |    |    |    |
|                       | String Block Type (0), cont. |   |   |   |   |   |   |                                       | String Block Length   |   |    |    |    |    |    |                  |    |    |    |    |    |    |    |              |    |    |    |    |    |    |    |    |
|                       | String Block Length, cont.   |   |   |   |   |   |   |                                       | URI...                |   |    |    |    |    |    |                  |    |    |    |    |    |    |    |              |    |    |    |    |    |    |    |    |
| Signature             | String Block Type (0)        |   |   |   |   |   |   |                                       |                       |   |    |    |    |    |    |                  |    |    |    |    |    |    |    |              |    |    |    |    |    |    |    |    |
|                       | String Block Length          |   |   |   |   |   |   |                                       |                       |   |    |    |    |    |    |                  |    |    |    |    |    |    |    |              |    |    |    |    |    |    |    |    |
|                       | Signature...                 |   |   |   |   |   |   |                                       |                       |   |    |    |    |    |    |                  |    |    |    |    |    |    |    |              |    |    |    |    |    |    |    |    |
| Source Port           |                              |   |   |   |   |   |   |                                       |                       |   |    |    |    |    |    | Destination Port |    |    |    |    |    |    |    |              |    |    |    |    |    |    |    |    |
| Protocol              |                              |   |   |   |   |   |   | Access Control Policy UUID            |                       |   |    |    |    |    |    |                  |    |    |    |    |    |    |    |              |    |    |    |    |    |    |    |    |
| AC Pol UUID, cont.    |                              |   |   |   |   |   |   | Access Control Policy UUID, continued |                       |   |    |    |    |    |    |                  |    |    |    |    |    |    |    |              |    |    |    |    |    |    |    |    |
|                       |                              |   |   |   |   |   |   | Access Control Policy UUID, continued |                       |   |    |    |    |    |    |                  |    |    |    |    |    |    |    |              |    |    |    |    |    |    |    |    |
|                       |                              |   |   |   |   |   |   | Access Control Policy UUID, continued |                       |   |    |    |    |    |    |                  |    |    |    |    |    |    |    |              |    |    |    |    |    |    |    |    |
| AC Pol UUID, cont.    |                              |   |   |   |   |   |   | Source Country                        |                       |   |    |    |    |    |    |                  |    |    |    |    |    |    |    | Dst. Country |    |    |    |    |    |    |    |    |
| Dst. Country, cont.   |                              |   |   |   |   |   |   | Web Application ID                    |                       |   |    |    |    |    |    |                  |    |    |    |    |    |    |    |              |    |    |    |    |    |    |    |    |
| Web App. ID, cont.    |                              |   |   |   |   |   |   | Client Application ID                 |                       |   |    |    |    |    |    |                  |    |    |    |    |    |    |    |              |    |    |    |    |    |    |    |    |
| Client App. ID, cont. |                              |   |   |   |   |   |   |                                       |                       |   |    |    |    |    |    |                  |    |    |    |    |    |    |    |              |    |    |    |    |    |    |    |    |

The following table describes the fields in the file event data block.

**Table B-27 File Event Data Block Fields**

| Field                   | Data Type | Description                                                                                                                                                          |
|-------------------------|-----------|----------------------------------------------------------------------------------------------------------------------------------------------------------------------|
| File Event Block Type   | uint32    | Initiates whether file event data block. This value is always 23.                                                                                                    |
| File Event Block Length | uint32    | Total number of bytes in the file event block, including eight bytes for the file event block type and length fields, plus the number of bytes of data that follows. |
| Device ID               | uint32    | ID for the device that generated the event.                                                                                                                          |
| Connection Instance     | uint16    | Snort instance on the device that generated the event. Used to link the event with a connection or intrusion event.                                                  |

Table B-27 File Event Data Block Fields (continued)

| Field                  | Data Type | Description                                                                                                                                                                                                                                                                                                                                                                                                                                                                                                                                                                             |
|------------------------|-----------|-----------------------------------------------------------------------------------------------------------------------------------------------------------------------------------------------------------------------------------------------------------------------------------------------------------------------------------------------------------------------------------------------------------------------------------------------------------------------------------------------------------------------------------------------------------------------------------------|
| Connection Counter     | uint16    | Value used to distinguish between connection events that happen during the same second.                                                                                                                                                                                                                                                                                                                                                                                                                                                                                                 |
| Connection Timestamp   | uint32    | UNIX timestamp (seconds since 01/01/1970) of the associated connection event.                                                                                                                                                                                                                                                                                                                                                                                                                                                                                                           |
| File Event Timestamp   | uint32    | UNIX timestamp (seconds since 01/01/1970) of when the file type is identified and the file event generated.                                                                                                                                                                                                                                                                                                                                                                                                                                                                             |
| Source IP Address      | uint8[16] | IPv4 or IPv6 address for the source of the connection.                                                                                                                                                                                                                                                                                                                                                                                                                                                                                                                                  |
| Destination IP Address | uint8[16] | IPv4 or IPv6 address for the destination of the connection.                                                                                                                                                                                                                                                                                                                                                                                                                                                                                                                             |
| Disposition            | uint8     | The malware status of the file. Possible values include: <ul style="list-style-type: none"> <li>1 - CLEAN The file is clean and does not contain malware.</li> <li>2 - UNKNOWN It is unknown whether the file contains malware.</li> <li>3 - MALWARE The file contains malware.</li> <li>4 - UNAVAILABLE The software was unable to send a request to the Cisco cloud for a disposition, or the Cisco cloud services did not respond to the request.</li> <li>5 - CUSTOM SIGNATURE The file matches a user-defined hash, and is treated in a fashion designated by the user.</li> </ul> |
| SPERO Disposition      | uint8     | Indicates whether the SPERO signature was used in file analysis. If the value is 1, 2, or 3, SPERO analysis was used. If there is any other value SPERO analysis was not used.                                                                                                                                                                                                                                                                                                                                                                                                          |
| File Storage Status    | uint8     | The storage status of the file. Possible values are: <ul style="list-style-type: none"> <li>1 - File Stored</li> <li>2 - File Stored</li> <li>3 - Unable to Store File</li> <li>4 - Unable to Store File</li> <li>5 - Unable to Store File</li> <li>6 - Unable to Store File</li> <li>7 - Unable to Store File</li> <li>8 - File Size is Too Large</li> <li>9 - File Size is Too Small</li> <li>10 - Unable to Store File</li> <li>11 - File Not Stored, Disposition Unavailable</li> </ul>                                                                                             |



Table B-27 File Event Data Block Fields (continued)

| Field                | Data Type | Description                                                                                                                                                                                                                                                                                                                                                                                                                                                                                                                                                                                                                                                                                                                                                                                                                                                                                                                           |
|----------------------|-----------|---------------------------------------------------------------------------------------------------------------------------------------------------------------------------------------------------------------------------------------------------------------------------------------------------------------------------------------------------------------------------------------------------------------------------------------------------------------------------------------------------------------------------------------------------------------------------------------------------------------------------------------------------------------------------------------------------------------------------------------------------------------------------------------------------------------------------------------------------------------------------------------------------------------------------------------|
| File Analysis Status | uint8     | Indicates whether the file was sent for dynamic analysis. Possible values are: <ul style="list-style-type: none"> <li>• 1 - Sent for Analysis</li> <li>• 2 - Sent for Analysis</li> <li>• 4 - Sent for Analysis</li> <li>• 5 - Failed to Send</li> <li>• 6 - Failed to Send</li> <li>• 7 - Failed to Send</li> <li>• 8 - Failed to Send</li> <li>• 9 - File Size is Too Small</li> <li>• 10 - File Size is Too Large</li> <li>• 11 - Sent for Analysis</li> <li>• 12 - Analysis Complete</li> <li>• 13 - Failure (Network Issue)</li> <li>• 14 - Failure (Rate Limit)</li> <li>• 15 - Failure (File Too Large)</li> <li>• 16 - Failure (File Read Error)</li> <li>• 17 - Failure (Internal Library Error)</li> <li>• 19 - File Not Sent, Disposition Unavailable</li> <li>• 20 - Failure (Cannot Run File)</li> <li>• 21 - Failure (Analysis Timeout)</li> <li>• 22 - Sent for Analysis</li> <li>• 23 - File Not Supported</li> </ul> |
| Archive File Status  | uint8     | This is always 0.                                                                                                                                                                                                                                                                                                                                                                                                                                                                                                                                                                                                                                                                                                                                                                                                                                                                                                                     |
| Threat Score         | uint8     | A numeric value from 0 to 100 based on the potentially malicious behaviors observed during dynamic analysis.                                                                                                                                                                                                                                                                                                                                                                                                                                                                                                                                                                                                                                                                                                                                                                                                                          |
| Action               | uint8     | The action taken on the file based on the file type. Can have the following values: <ul style="list-style-type: none"> <li>• 1 - Detect</li> <li>• 2 - Block</li> <li>• 3 - Malware Cloud Lookup</li> <li>• 4 - Malware Block</li> <li>• 5 - Malware Whitelist</li> </ul>                                                                                                                                                                                                                                                                                                                                                                                                                                                                                                                                                                                                                                                             |
| SHA Hash             | uint8[32] | SHA-256 hash of the file, in binary format.                                                                                                                                                                                                                                                                                                                                                                                                                                                                                                                                                                                                                                                                                                                                                                                                                                                                                           |

Table B-27 File Event Data Block Fields (continued)

| Field                      | Data Type | Description                                                                                                                                                                                                                                                                                |
|----------------------------|-----------|--------------------------------------------------------------------------------------------------------------------------------------------------------------------------------------------------------------------------------------------------------------------------------------------|
| File Type ID               | uint32    | ID number that maps to the file type. The meaning of this field is transmitted in the metadata with this event. See <a href="#">FireAMP File Type Metadata, page 3-35</a> for more information.                                                                                            |
| File Name                  | string    | Name of the file.                                                                                                                                                                                                                                                                          |
| File Size                  | uint64    | Size of the file in bytes.                                                                                                                                                                                                                                                                 |
| Direction                  | uint8     | Value that indicates whether the file was uploaded or downloaded. Can have the following values: <ul style="list-style-type: none"> <li>1 - Download</li> <li>2 - Upload</li> </ul> Currently the value depends on the protocol (for example, if the connection is HTTP it is a download). |
| Application ID             | uint32    | ID number that maps to the application using the file transfer.                                                                                                                                                                                                                            |
| User ID                    | uint32    | ID number for the user logged into the destination host, as identified by the system.                                                                                                                                                                                                      |
| URI                        | string    | Uniform Resource Identifier (URI) of the connection.                                                                                                                                                                                                                                       |
| Signature                  | string    | SHA-256 hash of the file, in string format.                                                                                                                                                                                                                                                |
| Source Port                | uint16    | Port number for the source of the connection.                                                                                                                                                                                                                                              |
| Destination Port           | uint16    | Port number for the destination of the connection.                                                                                                                                                                                                                                         |
| Protocol                   | uint8     | IANA protocol number specified by the user. For example: <ul style="list-style-type: none"> <li>1 - ICMP</li> <li>4 - IP</li> <li>6 - TCP</li> <li>17 - UDP</li> </ul> This is currently only TCP.                                                                                         |
| Access Control Policy UUID | uint8[16] | Unique identifier for the access control policy that triggered the event.                                                                                                                                                                                                                  |
| Source Country             | uint16    | Code for the country of the source host.                                                                                                                                                                                                                                                   |
| Destination Country        | uint16    | Code for the country of the destination host.                                                                                                                                                                                                                                              |
| Web Application ID         | uint32    | The internal identification number for the web application, if applicable.                                                                                                                                                                                                                 |
| Client Application ID      | uint32    | The internal identification number for the client application, if applicable.                                                                                                                                                                                                              |

## File Event SHA Hash for 5.1.1-5.2.x

The eStreamer service uses the File Event SHA Hash data block to contain metadata of the mapping of the SHA hash of a file to its filename. The block type is 26 in the series 2 list of data blocks. It can be requested if file log events have been requested in the extended requests—event code 111—and either bit 20 is set or metadata is requested with an event version of 4 and an event code of 21.

The following diagram shows the structure of a file event hash data block:

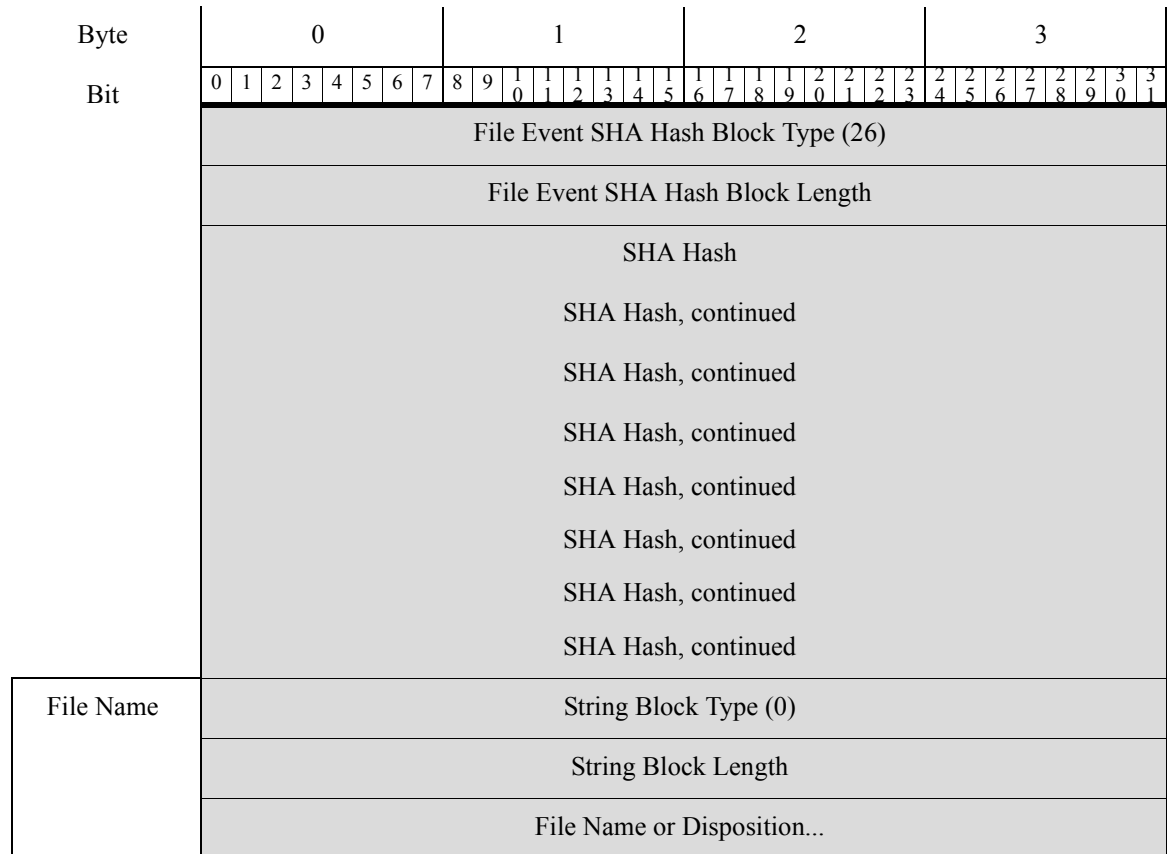

The following table describes the fields in the file event SHA hash data block.

**Table B-28** File Event SHA Hash 5.1.1-5.2.x Data Block Fields

| Field                            | Data Type | Description                                                                                                                                                                            |
|----------------------------------|-----------|----------------------------------------------------------------------------------------------------------------------------------------------------------------------------------------|
| File Event SHA Hash Block Type   | uint32    | Initiates a File Event SHA Hash block. This value is always 26.                                                                                                                        |
| File Event SHA Hash Block Length | uint32    | Total number of bytes in the File Event SHA Hash block, including eight bytes for the File Event SHA Hash block type and length fields, plus the number of bytes of data that follows. |
| SHA Hash                         | uint8[32] | The SHA-256 hash of the file in binary format.                                                                                                                                         |
| String Block Type                | uint32    | Initiates a String data block containing the descriptive name associated with the file. This value is always 0.                                                                        |

Table B-28 File Event SHA Hash 5.1.1-5.2.x Data Block Fields (continued)

| Field                    | Data Type | Description                                                                                                                                                                                                                               |
|--------------------------|-----------|-------------------------------------------------------------------------------------------------------------------------------------------------------------------------------------------------------------------------------------------|
| String Block Length      | uint32    | The number of bytes included in the name String data block, including eight bytes for the block type and header fields plus the number of bytes in the Name field.                                                                        |
| File Name or Disposition | string    | The descriptive name or disposition of the file. If the file is clean, this value is <code>clean</code> . If the file's disposition is unknown, the value is <code>Neutral</code> . If the file contains malware, the file name is given. |

## Legacy Correlation Event Data Structures

The following topic describes other legacy correlation (compliance) data structures:

- [Correlation Event for 5.0 - 5.0.2, page B-124](#)

### Correlation Event for 5.0 - 5.0.2

Correlation events (called compliance events in pre-5.0 versions) contain information about correlation policy violations. This message uses the standard eStreamer message header and specifies a record type of 112, followed by a correlation data block of type 116. Data block type 116 differs from its predecessor (block type 107) in including additional information about the associated security zone and interface.

You can request 5.0 correlation events from eStreamer only by extended request, for which you request event type code 31 and version code 7 in the Stream Request message (see [Submitting Extended Requests, page 2-4](#) for information about submitting extended requests). You can optionally enable bit 23 in the flags field of the initial event stream request message, to include the extended event header. You can also enable bit 20 in the flags field to include user metadata.

Note that the record structure includes a String block type, which is a block in series 1. For information about series 1 blocks, see [Understanding Discovery \(Series 1\) Blocks, page 4-55](#).

| Byte                                                          | 0 |   |   |   |   |   |   |   | 1 |   |    |    |    |    |    |                  | 2  |    |    |    |    |    |    |    | 3  |    |    |    |    |    |    |    |
|---------------------------------------------------------------|---|---|---|---|---|---|---|---|---|---|----|----|----|----|----|------------------|----|----|----|----|----|----|----|----|----|----|----|----|----|----|----|----|
| Bit                                                           | 0 | 1 | 2 | 3 | 4 | 5 | 6 | 7 | 8 | 9 | 10 | 11 | 12 | 13 | 14 | 15               | 16 | 17 | 18 | 19 | 20 | 21 | 22 | 23 | 24 | 25 | 26 | 27 | 28 | 29 | 30 | 31 |
| Header Version (1)                                            |   |   |   |   |   |   |   |   |   |   |    |    |    |    |    | Message Type (4) |    |    |    |    |    |    |    |    |    |    |    |    |    |    |    |    |
| Message Length                                                |   |   |   |   |   |   |   |   |   |   |    |    |    |    |    |                  |    |    |    |    |    |    |    |    |    |    |    |    |    |    |    |    |
| Record Type (112)                                             |   |   |   |   |   |   |   |   |   |   |    |    |    |    |    |                  |    |    |    |    |    |    |    |    |    |    |    |    |    |    |    |    |
| Record Length                                                 |   |   |   |   |   |   |   |   |   |   |    |    |    |    |    |                  |    |    |    |    |    |    |    |    |    |    |    |    |    |    |    |    |
| eStreamer Server Timestamp (in events, only if bit 23 is set) |   |   |   |   |   |   |   |   |   |   |    |    |    |    |    |                  |    |    |    |    |    |    |    |    |    |    |    |    |    |    |    |    |
| Reserved for Future Use (in events, only if bit 23 is set)    |   |   |   |   |   |   |   |   |   |   |    |    |    |    |    |                  |    |    |    |    |    |    |    |    |    |    |    |    |    |    |    |    |
| Correlation Block Type (116)                                  |   |   |   |   |   |   |   |   |   |   |    |    |    |    |    |                  |    |    |    |    |    |    |    |    |    |    |    |    |    |    |    |    |

|                                       |   |   |   |   |   |   |   |                |   |   |    |    |    |    |    |                  |    |    |    |    |    |    |    |                     |    |    |    |    |    |    |    |    |
|---------------------------------------|---|---|---|---|---|---|---|----------------|---|---|----|----|----|----|----|------------------|----|----|----|----|----|----|----|---------------------|----|----|----|----|----|----|----|----|
| By<br>te                              | 0 |   |   |   |   |   |   |                | 1 |   |    |    |    |    |    |                  | 2  |    |    |    |    |    |    |                     | 3  |    |    |    |    |    |    |    |
|                                       | 0 | 1 | 2 | 3 | 4 | 5 | 6 | 7              | 8 | 9 | 10 | 11 | 12 | 13 | 14 | 15               | 16 | 17 | 18 | 19 | 20 | 21 | 22 | 23                  | 24 | 25 | 26 | 27 | 28 | 29 | 30 | 31 |
| Bit                                   |   |   |   |   |   |   |   |                |   |   |    |    |    |    |    |                  |    |    |    |    |    |    |    |                     |    |    |    |    |    |    |    |    |
| Correlation Block Length              |   |   |   |   |   |   |   |                |   |   |    |    |    |    |    |                  |    |    |    |    |    |    |    |                     |    |    |    |    |    |    |    |    |
| Device ID                             |   |   |   |   |   |   |   |                |   |   |    |    |    |    |    |                  |    |    |    |    |    |    |    |                     |    |    |    |    |    |    |    |    |
| (Correlation) Event Second            |   |   |   |   |   |   |   |                |   |   |    |    |    |    |    |                  |    |    |    |    |    |    |    |                     |    |    |    |    |    |    |    |    |
| Event ID                              |   |   |   |   |   |   |   |                |   |   |    |    |    |    |    |                  |    |    |    |    |    |    |    |                     |    |    |    |    |    |    |    |    |
| Policy ID                             |   |   |   |   |   |   |   |                |   |   |    |    |    |    |    |                  |    |    |    |    |    |    |    |                     |    |    |    |    |    |    |    |    |
| Rule ID                               |   |   |   |   |   |   |   |                |   |   |    |    |    |    |    |                  |    |    |    |    |    |    |    |                     |    |    |    |    |    |    |    |    |
| Priority                              |   |   |   |   |   |   |   |                |   |   |    |    |    |    |    |                  |    |    |    |    |    |    |    |                     |    |    |    |    |    |    |    |    |
| String Block Type (0)                 |   |   |   |   |   |   |   |                |   |   |    |    |    |    |    |                  |    |    |    |    |    |    |    |                     |    |    |    |    |    |    |    |    |
| String Block Length                   |   |   |   |   |   |   |   |                |   |   |    |    |    |    |    |                  |    |    |    |    |    |    |    |                     |    |    |    |    |    |    |    |    |
| Description...                        |   |   |   |   |   |   |   |                |   |   |    |    |    |    |    |                  |    |    |    |    |    |    |    | Event Type          |    |    |    |    |    |    |    |    |
| Event Device ID                       |   |   |   |   |   |   |   |                |   |   |    |    |    |    |    |                  |    |    |    |    |    |    |    |                     |    |    |    |    |    |    |    |    |
| Signature ID                          |   |   |   |   |   |   |   |                |   |   |    |    |    |    |    |                  |    |    |    |    |    |    |    |                     |    |    |    |    |    |    |    |    |
| Signature Generator ID                |   |   |   |   |   |   |   |                |   |   |    |    |    |    |    |                  |    |    |    |    |    |    |    |                     |    |    |    |    |    |    |    |    |
| (Trigger) Event Second                |   |   |   |   |   |   |   |                |   |   |    |    |    |    |    |                  |    |    |    |    |    |    |    |                     |    |    |    |    |    |    |    |    |
| (Trigger) Event Microsecond           |   |   |   |   |   |   |   |                |   |   |    |    |    |    |    |                  |    |    |    |    |    |    |    |                     |    |    |    |    |    |    |    |    |
| Event ID                              |   |   |   |   |   |   |   |                |   |   |    |    |    |    |    |                  |    |    |    |    |    |    |    |                     |    |    |    |    |    |    |    |    |
| Event Defined Mask                    |   |   |   |   |   |   |   |                |   |   |    |    |    |    |    |                  |    |    |    |    |    |    |    |                     |    |    |    |    |    |    |    |    |
| Event Impact Flags                    |   |   |   |   |   |   |   | IP Protocol    |   |   |    |    |    |    |    | Network Protocol |    |    |    |    |    |    |    |                     |    |    |    |    |    |    |    |    |
| Source IP                             |   |   |   |   |   |   |   |                |   |   |    |    |    |    |    |                  |    |    |    |    |    |    |    |                     |    |    |    |    |    |    |    |    |
| Source Host Type                      |   |   |   |   |   |   |   | Source VLAN ID |   |   |    |    |    |    |    |                  |    |    |    |    |    |    |    | Source OS Fprt UUID |    |    |    |    |    |    |    |    |
| Source OS Fingerprint UUID, continued |   |   |   |   |   |   |   |                |   |   |    |    |    |    |    |                  |    |    |    |    |    |    |    |                     |    |    |    |    |    |    |    |    |
| Source OS Fingerprint UUID, continued |   |   |   |   |   |   |   |                |   |   |    |    |    |    |    |                  |    |    |    |    |    |    |    |                     |    |    |    |    |    |    |    |    |
| Source OS Fingerprint UUID, continued |   |   |   |   |   |   |   |                |   |   |    |    |    |    |    |                  |    |    |    |    |    |    |    |                     |    |    |    |    |    |    |    |    |
| Source OS Fingerprint UUID, continued |   |   |   |   |   |   |   |                |   |   |    |    |    |    |    |                  |    |    |    |    |    |    |    | Source Criticality  |    |    |    |    |    |    |    |    |
| Source Criticality, cont              |   |   |   |   |   |   |   | Source User ID |   |   |    |    |    |    |    |                  |    |    |    |    |    |    |    |                     |    |    |    |    |    |    |    |    |

Event Description

Source OS Fprt UUID

| By<br>te | 0                                          |   |   |   |   |   |   |   | 1                               |   |    |    |                        |    |    |    | 2                |    |    |    |    |    |    |    | 3                        |    |    |    |    |    |    |    |
|----------|--------------------------------------------|---|---|---|---|---|---|---|---------------------------------|---|----|----|------------------------|----|----|----|------------------|----|----|----|----|----|----|----|--------------------------|----|----|----|----|----|----|----|
|          | 0                                          | 1 | 2 | 3 | 4 | 5 | 6 | 7 | 8                               | 9 | 10 | 11 | 12                     | 13 | 14 | 15 | 16               | 17 | 18 | 19 | 20 | 21 | 22 | 23 | 24                       | 25 | 26 | 27 | 28 | 29 | 30 | 31 |
|          | Source User ID, cont                       |   |   |   |   |   |   |   | Source Port                     |   |    |    |                        |    |    |    | Source Server ID |    |    |    |    |    |    |    |                          |    |    |    |    |    |    |    |
|          | Source Server ID, continued                |   |   |   |   |   |   |   |                                 |   |    |    |                        |    |    |    | Destination IP   |    |    |    |    |    |    |    |                          |    |    |    |    |    |    |    |
|          | Destination IP, continued                  |   |   |   |   |   |   |   |                                 |   |    |    |                        |    |    |    | Dest. Host Type  |    |    |    |    |    |    |    |                          |    |    |    |    |    |    |    |
|          | Dest. VLAN ID                              |   |   |   |   |   |   |   | Destination OS Fingerprint UUID |   |    |    |                        |    |    |    |                  |    |    |    |    |    |    |    | Dest OS Fingerprint UUID |    |    |    |    |    |    |    |
|          | Destination OS Fingerprint UUID, continued |   |   |   |   |   |   |   |                                 |   |    |    |                        |    |    |    |                  |    |    |    |    |    |    |    |                          |    |    |    |    |    |    |    |
|          | Destination OS Fingerprint UUID, continued |   |   |   |   |   |   |   |                                 |   |    |    |                        |    |    |    |                  |    |    |    |    |    |    |    |                          |    |    |    |    |    |    |    |
|          | Destination OS Fingerprint UUID, continued |   |   |   |   |   |   |   |                                 |   |    |    |                        |    |    |    |                  |    |    |    |    |    |    |    |                          |    |    |    |    |    |    |    |
|          | Destination OS Fingerprint UUID, continued |   |   |   |   |   |   |   | Destination Criticality         |   |    |    |                        |    |    |    |                  |    |    |    |    |    |    |    |                          |    |    |    |    |    |    |    |
|          | Dest. User ID                              |   |   |   |   |   |   |   |                                 |   |    |    |                        |    |    |    |                  |    |    |    |    |    |    |    |                          |    |    |    |    |    |    |    |
|          | Destination Port                           |   |   |   |   |   |   |   | Destination Server ID           |   |    |    |                        |    |    |    |                  |    |    |    |    |    |    |    |                          |    |    |    |    |    |    |    |
|          | Destination Server ID, cont.               |   |   |   |   |   |   |   | Blocked                         |   |    |    | Ingress Interface UUID |    |    |    |                  |    |    |    |    |    |    |    |                          |    |    |    |    |    |    |    |
|          | Ingress Interface UUID, continued          |   |   |   |   |   |   |   |                                 |   |    |    |                        |    |    |    |                  |    |    |    |    |    |    |    |                          |    |    |    |    |    |    |    |
|          | Ingress Interface UUID, continued          |   |   |   |   |   |   |   |                                 |   |    |    |                        |    |    |    |                  |    |    |    |    |    |    |    |                          |    |    |    |    |    |    |    |
|          | Ingress Interface UUID, continued          |   |   |   |   |   |   |   |                                 |   |    |    |                        |    |    |    |                  |    |    |    |    |    |    |    |                          |    |    |    |    |    |    |    |
|          | Ingress Interface UUID, continued          |   |   |   |   |   |   |   | Egress Interface UUID           |   |    |    |                        |    |    |    |                  |    |    |    |    |    |    |    |                          |    |    |    |    |    |    |    |
|          | Egress Interface UUID, continued           |   |   |   |   |   |   |   |                                 |   |    |    |                        |    |    |    |                  |    |    |    |    |    |    |    |                          |    |    |    |    |    |    |    |
|          | Egress Interface UUID, continued           |   |   |   |   |   |   |   |                                 |   |    |    |                        |    |    |    |                  |    |    |    |    |    |    |    |                          |    |    |    |    |    |    |    |
|          | Egress Interface UUID, continued           |   |   |   |   |   |   |   |                                 |   |    |    |                        |    |    |    |                  |    |    |    |    |    |    |    |                          |    |    |    |    |    |    |    |
|          | Egress Interface UUID, continued           |   |   |   |   |   |   |   | Ingress Zone UUID               |   |    |    |                        |    |    |    |                  |    |    |    |    |    |    |    |                          |    |    |    |    |    |    |    |
|          | Ingress Zone UUID                          |   |   |   |   |   |   |   |                                 |   |    |    |                        |    |    |    |                  |    |    |    |    |    |    |    |                          |    |    |    |    |    |    |    |
|          | Ingress Zone UUID, continued               |   |   |   |   |   |   |   |                                 |   |    |    |                        |    |    |    |                  |    |    |    |    |    |    |    |                          |    |    |    |    |    |    |    |
|          | Ingress Zone UUID, continued               |   |   |   |   |   |   |   |                                 |   |    |    |                        |    |    |    |                  |    |    |    |    |    |    |    |                          |    |    |    |    |    |    |    |
|          | Ingress Zone UUID, continued               |   |   |   |   |   |   |   | Egress Zone UUID                |   |    |    |                        |    |    |    |                  |    |    |    |    |    |    |    |                          |    |    |    |    |    |    |    |

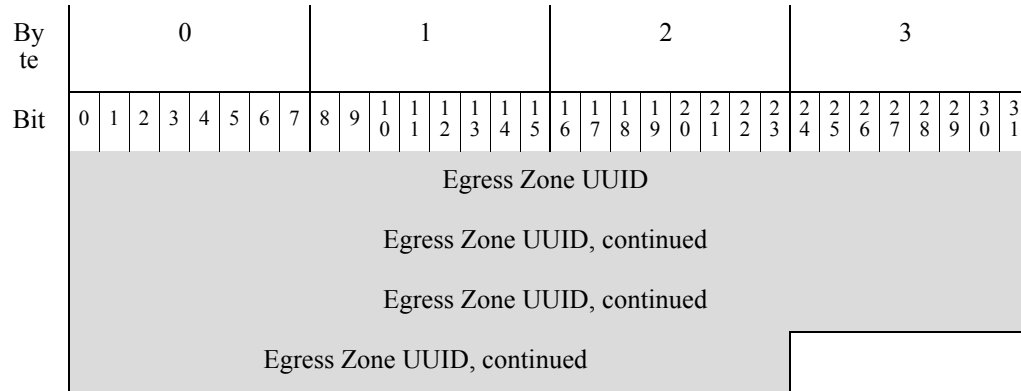

Table B-29 Correlation Event 5.0 - 5.0.2 Data Fields

| Field                      | Data Type | Description                                                                                                                                                                                                                                                                                                          |
|----------------------------|-----------|----------------------------------------------------------------------------------------------------------------------------------------------------------------------------------------------------------------------------------------------------------------------------------------------------------------------|
| Correlation Block Type     | uint32    | Indicates a correlation event data block follows. This field always has a value of 107. See <a href="#">Understanding Discovery (Series 1) Blocks, page 4-55</a> .                                                                                                                                                   |
| Correlation Block Length   | uint32    | Length of the correlation data block, which includes 8 bytes for the correlation block type and length plus the correlation data that follows.                                                                                                                                                                       |
| Device ID                  | uint32    | Internal identification number of the managed device or Defense Center that generated the correlation event. A value of zero indicates the Defense Center. You can obtain managed device names by requesting Version 3 metadata. See <a href="#">Managed Device Record Metadata, page 3-30</a> for more information. |
| (Correlation) Event Second | uint32    | UNIX timestamp indicating the time that the correlation event was generated (in seconds from 01/01/1970).                                                                                                                                                                                                            |
| Event ID                   | uint32    | Correlation event identification number.                                                                                                                                                                                                                                                                             |
| Policy ID                  | uint32    | Identification number of the correlation policy that was violated. See <a href="#">Server Record, page 4-14</a> for information about how to obtain policy identification numbers from the database.                                                                                                                 |
| Rule ID                    | uint32    | Identification number of the correlation rule that triggered to violate the policy. See <a href="#">Server Record, page 4-14</a> for information about how to obtain policy identification numbers from the database.                                                                                                |
| Priority                   | uint32    | Priority assigned to the event. This is an integer value from 0 to 5.                                                                                                                                                                                                                                                |
| String Block Type          | uint32    | Initiates a string data block that contains the correlation violation event description. This value is always set to 0. For more information about string blocks, see <a href="#">String Data Block, page 4-63</a> .                                                                                                 |
| String Block Length        | uint32    | Number of bytes in the event description string block, which includes four bytes for the string block type and four bytes for the string block length, plus the number of bytes in the description.                                                                                                                  |
| Description                | string    | Description of the correlation event.                                                                                                                                                                                                                                                                                |

Table B-29 Correlation Event 5.0 - 5.0.2 Data Fields (continued)

| Field                       | Data Type | Description                                                                                                                                                                                                                                         |
|-----------------------------|-----------|-----------------------------------------------------------------------------------------------------------------------------------------------------------------------------------------------------------------------------------------------------|
| Event Type                  | uint8     | Indicates whether the correlation event was triggered by an intrusion, host discovery, or user event: <ul style="list-style-type: none"> <li>• 1 - intrusion</li> <li>• 2 - host discovery</li> <li>• 3 - user</li> </ul>                           |
| Event Device ID             | uint32    | Identification number of the device that generated the event that triggered the correlation event. You can obtain device name by requesting Version 3 metadata. See <a href="#">Managed Device Record Metadata, page 3-30</a> for more information. |
| Signature ID                | uint32    | If the event was an intrusion event, indicates the rule identification number that corresponds with the event. Otherwise, the value is 0.                                                                                                           |
| Signature Generator ID      | uint32    | If the event was an intrusion event, indicates the ID number of the FireSIGHT System preprocessor or rules engine that generated the event.                                                                                                         |
| (Trigger) Event Second      | uint32    | UNIX timestamp indicating the time of the event that triggered the correlation policy rule (in seconds from 01/01/1970).                                                                                                                            |
| (Trigger) Event Microsecond | uint32    | Microsecond (one millionth of a second) increment that the event was detected.                                                                                                                                                                      |
| Event ID                    | uint32    | Identification number of the event generated by the device.                                                                                                                                                                                         |
| Event Defined Mask          | bits[32]  | Set bits in this field indicate which of the fields that follow in the message are valid. See <a href="#">Table B-30 on page B-131</a> for a list of each bit value.                                                                                |



Table B-29 Correlation Event 5.0 - 5.0.2 Data Fields (continued)

| Field              | Data Type | Description                                                                                                                                                                                                                                                                                                                                                                                                                                                                                                                                                                                                                                                                                                                                                                                                                                                                                                                                                                                                                                                                                                                                                                                                                                                                                                                                                                                                                                                                                                                                                                                                                                                                                                                      |
|--------------------|-----------|----------------------------------------------------------------------------------------------------------------------------------------------------------------------------------------------------------------------------------------------------------------------------------------------------------------------------------------------------------------------------------------------------------------------------------------------------------------------------------------------------------------------------------------------------------------------------------------------------------------------------------------------------------------------------------------------------------------------------------------------------------------------------------------------------------------------------------------------------------------------------------------------------------------------------------------------------------------------------------------------------------------------------------------------------------------------------------------------------------------------------------------------------------------------------------------------------------------------------------------------------------------------------------------------------------------------------------------------------------------------------------------------------------------------------------------------------------------------------------------------------------------------------------------------------------------------------------------------------------------------------------------------------------------------------------------------------------------------------------|
| Event Impact Flags | bits[8]   | <p>Impact flag value of the event. The low-order eight bits indicate the impact level. Values are:</p> <ul style="list-style-type: none"> <li>0x01 (bit 0) - Source or destination host is in a network monitored by the system.</li> <li>0x02 (bit 1) - Source or destination host exists in the network map.</li> <li>0x04 (bit 2) - Source or destination host is running a server on the port in the event (if TCP or UDP) or uses the IP protocol.</li> <li>0x08 (bit 3) - There is a vulnerability mapped to the operating system of the source or destination host in the event.</li> <li>0x10 (bit 4) - There is a vulnerability mapped to the server detected in the event.</li> <li>0x20 (bit 5) - The event caused the managed device to drop the session (used only when the device is running in inline, switched, or routed deployment). Corresponds to blocked status in the FireSIGHT System web interface.</li> <li>0x40 (bit 6) - The rule that generated this event contains rule metadata setting the impact flag to red (bit 6). The source or destination host is potentially compromised by a virus, trojan, or other piece of malicious software.</li> <li>0x80 (bit 7) - There is a vulnerability mapped to the client detected in the event.</li> </ul> <p>The following impact level values map to specific priorities on the Defense Center. An x indicates the value can be 0 or 1:</p> <ul style="list-style-type: none"> <li>gray (0, unknown): 00x00000</li> <li>red (1, vulnerable): xxx1xxx, xxx1xxxx, x1xxxxxx, 1xxxxxxx</li> <li>orange (2, potentially vulnerable): 00x00111</li> <li>yellow (3, currently not vulnerable): 00x00011</li> <li>blue (4, unknown target): 00x00001</li> </ul> |
| IP Protocol        | uint8     | Identifier of the IP protocol associated with the event, if applicable.                                                                                                                                                                                                                                                                                                                                                                                                                                                                                                                                                                                                                                                                                                                                                                                                                                                                                                                                                                                                                                                                                                                                                                                                                                                                                                                                                                                                                                                                                                                                                                                                                                                          |
| Network Protocol   | uint16    | Network protocol associated with the event, if applicable.                                                                                                                                                                                                                                                                                                                                                                                                                                                                                                                                                                                                                                                                                                                                                                                                                                                                                                                                                                                                                                                                                                                                                                                                                                                                                                                                                                                                                                                                                                                                                                                                                                                                       |
| Source IP          | uint8[4]  | IP address of the source host in the event, in IP address octets.                                                                                                                                                                                                                                                                                                                                                                                                                                                                                                                                                                                                                                                                                                                                                                                                                                                                                                                                                                                                                                                                                                                                                                                                                                                                                                                                                                                                                                                                                                                                                                                                                                                                |
| Source Host Type   | uint8     | <p>Source host's type:</p> <ul style="list-style-type: none"> <li>0 - Host</li> <li>1 - Router</li> <li>2 - Bridge</li> </ul>                                                                                                                                                                                                                                                                                                                                                                                                                                                                                                                                                                                                                                                                                                                                                                                                                                                                                                                                                                                                                                                                                                                                                                                                                                                                                                                                                                                                                                                                                                                                                                                                    |
| Source VLAN ID     | uint16    | Source host's VLAN identification number, if applicable.                                                                                                                                                                                                                                                                                                                                                                                                                                                                                                                                                                                                                                                                                                                                                                                                                                                                                                                                                                                                                                                                                                                                                                                                                                                                                                                                                                                                                                                                                                                                                                                                                                                                         |

Table B-29 Correlation Event 5.0 - 5.0.2 Data Fields (continued)

| Field                           | Data Type | Description                                                                                                                                                                                                                           |
|---------------------------------|-----------|---------------------------------------------------------------------------------------------------------------------------------------------------------------------------------------------------------------------------------------|
| Source OS Fingerprint UUID      | uint8[16] | A fingerprint ID number that acts a unique identifier for the source host's operating system.<br><br>See <a href="#">Server Record, page 4-14</a> for information about obtaining the values that map to the fingerprint IDs.         |
| Source Criticality              | uint16    | User-defined criticality value for the source host: <ul style="list-style-type: none"> <li>• 0 - None</li> <li>• 1 - Low</li> <li>• 2 - Medium</li> <li>• 3 - High</li> </ul>                                                         |
| Source User ID                  | uint32    | Identification number for the user logged into the source host, as identified by the system.                                                                                                                                          |
| Source Port                     | uint16    | Source port in the event.                                                                                                                                                                                                             |
| Source Server ID                | uint32    | Identification number for the server running on the source host.                                                                                                                                                                      |
| Destination IP Address          | uint8[4]  | IP address of the destination host associated with the policy violation (if applicable). This value will be 0 if there is no destination IP address.                                                                                  |
| Destination Host Type           | uint8     | Destination host's type: <ul style="list-style-type: none"> <li>• 0 - Host</li> <li>• 1 - Router</li> <li>• 2 - Bridge</li> </ul>                                                                                                     |
| Destination VLAN ID             | uint16    | Destination host's VLAN identification number, if applicable.                                                                                                                                                                         |
| Destination OS Fingerprint UUID | uint8[16] | A fingerprint ID number that acts as a unique identifier for the destination host's operating system.<br><br>See <a href="#">Server Record, page 4-14</a> for information about obtaining the values that map to the fingerprint IDs. |
| Destination Criticality         | uint16    | User-defined criticality value for the destination host: <ul style="list-style-type: none"> <li>• 0 - None</li> <li>• 1 - Low</li> <li>• 2 - Medium</li> <li>• 3 - High</li> </ul>                                                    |
| Destination User ID             | uint32    | Identification number for the user logged into the destination host, as identified by the system.                                                                                                                                     |
| Destination Port                | uint16    | Destination port in the event.                                                                                                                                                                                                        |
| Destination Service ID          | uint32    | Identification number for the server running on the source host.                                                                                                                                                                      |

**Table B-29** Correlation Event 5.0 - 5.0.2 Data Fields (continued)

| Field                  | Data Type | Description                                                                                                                                                                                                                                                                                                                                                                                                                                 |
|------------------------|-----------|---------------------------------------------------------------------------------------------------------------------------------------------------------------------------------------------------------------------------------------------------------------------------------------------------------------------------------------------------------------------------------------------------------------------------------------------|
| Blocked                | uint8     | Value indicating what happened to the packet that triggered the intrusion event. <ul style="list-style-type: none"> <li>0 - Intrusion event not dropped</li> <li>1 - Intrusion event was dropped (drop when deployment is inline, switched, or routed)</li> <li>2 - The packet that triggered the event would have been dropped, if the intrusion policy had been applied to a device in inline, switched, or routed deployment.</li> </ul> |
| Ingress Interface UUID | uint8[16] | An interface ID that acts as the unique identifier for the ingress interface associated with correlation event.                                                                                                                                                                                                                                                                                                                             |
| Egress Interface UUID  | uint8[16] | An interface ID that acts as the unique identifier for the egress interface associated with correlation event.                                                                                                                                                                                                                                                                                                                              |
| Ingress Zone UUID      | uint8[16] | A zone ID that acts as the unique identifier for the ingress security zone associated with correlation event.                                                                                                                                                                                                                                                                                                                               |
| Egress Zone UUID       | uint8[16] | A zone ID that acts as the unique identifier for the egress security zone associated with correlation event.                                                                                                                                                                                                                                                                                                                                |

The following table describes each Event Defined Mask value.

**Table B-30** Event Defined Values

| Description                | Mask Value |
|----------------------------|------------|
| Event Impact Flags         | 0x00000001 |
| IP Protocol                | 0x00000002 |
| Network Protocol           | 0x00000004 |
| Source IP                  | 0x00000008 |
| Source Host Type           | 0x00000010 |
| Source VLAN ID             | 0x00000020 |
| Source Fingerprint ID      | 0x00000040 |
| Source Criticality         | 0x00000080 |
| Source Port                | 0x00000100 |
| Source Server              | 0x00000200 |
| Destination IP             | 0x00000400 |
| Destination Host Type      | 0x00000800 |
| Destination VLAN ID        | 0x00001000 |
| Destination Fingerprint ID | 0x00002000 |
| Destination Criticality    | 0x00004000 |
| Destination Port           | 0x00008000 |
| Destination Server         | 0x00010000 |

Table B-30 Event Defined Values (continued)

| Description      | Mask Value |
|------------------|------------|
| Source User      | 0x00020000 |
| Destination User | 0x00040000 |

## Legacy Host Data Structures

To request these structures, you must use a Host Request Message. To request a legacy structure, the Host Request Message must use an older format. See [Host Request Message Format, page 2-24](#) for more information.

The following topics describe legacy host data structures, including both host profile and full host profile structures:

- [Full Host Profile Data Block 5.0 - 5.0.2, page B-132](#)
- [Full Host Profile Data Block 5.1.1, page B-141](#)
- [Full Host Profile Data Block 5.2.x, page B-150](#)
- [Host Profile Data Block for 5.1.x, page B-162](#)
- [IP Range Specification Data Block for 5.0 - 5.1.1.x, page B-168](#)

## Full Host Profile Data Block 5.0 - 5.0.2

The Full Host Profile data block for version 5.0 - 5.0.2 contains a full set of data describing one host. It has the format shown in the graphic below and explained in the following table. Note that, except for List data blocks, the graphic does not show the fields of the encapsulated data blocks. These encapsulated data blocks are described separately in [Understanding Discovery & Connection Data Structures, page 4-1](#). The Full Host Profile data block a block type value of 111.



**Note**

An asterisk(\*) next to a block name in the following diagram indicates that multiple instances of the data block may occur.

| Byte                               | 0 |   |   |   |   |   |   |                              | 1 |   |   |   |   |   |   |   | 2 |   |   |   |   |   |   |   | 3 |   |   |   |   |   |   |   |   |   |   |   |   |   |   |   |
|------------------------------------|---|---|---|---|---|---|---|------------------------------|---|---|---|---|---|---|---|---|---|---|---|---|---|---|---|---|---|---|---|---|---|---|---|---|---|---|---|---|---|---|---|---|
| Bit                                | 0 | 1 | 2 | 3 | 4 | 5 | 6 | 7                            | 8 | 9 | 0 | 1 | 2 | 3 | 4 | 5 | 6 | 7 | 8 | 9 | 0 | 1 | 2 | 3 | 4 | 5 | 6 | 7 | 8 | 9 | 0 | 1 | 2 | 3 | 4 | 5 | 6 | 7 | 8 | 9 |
| Full Host Profile Data Block (111) |   |   |   |   |   |   |   |                              |   |   |   |   |   |   |   |   |   |   |   |   |   |   |   |   |   |   |   |   |   |   |   |   |   |   |   |   |   |   |   |   |
| Data Block Length                  |   |   |   |   |   |   |   |                              |   |   |   |   |   |   |   |   |   |   |   |   |   |   |   |   |   |   |   |   |   |   |   |   |   |   |   |   |   |   |   |   |
| IP Address                         |   |   |   |   |   |   |   |                              |   |   |   |   |   |   |   |   |   |   |   |   |   |   |   |   |   |   |   |   |   |   |   |   |   |   |   |   |   |   |   |   |
| Hops                               |   |   |   |   |   |   |   | Generic List Block Type (31) |   |   |   |   |   |   |   |   |   |   |   |   |   |   |   |   |   |   |   |   |   |   |   |   |   |   |   |   |   |   |   |   |
| Generic List Block Type, continued |   |   |   |   |   |   |   | Generic List Block Length    |   |   |   |   |   |   |   |   |   |   |   |   |   |   |   |   |   |   |   |   |   |   |   |   |   |   |   |   |   |   |   |   |

| Byte                      | 0                                              |   |   |   |   |   |   | 1                                              |   |   |    |    |    |    | 2  |    |    |    |    |    |    | 3  |    |    |    |    |    |    |    |    |    |    |  |  |  |  |  |  |
|---------------------------|------------------------------------------------|---|---|---|---|---|---|------------------------------------------------|---|---|----|----|----|----|----|----|----|----|----|----|----|----|----|----|----|----|----|----|----|----|----|----|--|--|--|--|--|--|
|                           | 0                                              | 1 | 2 | 3 | 4 | 5 | 6 | 7                                              | 8 | 9 | 10 | 11 | 12 | 13 | 14 | 15 | 16 | 17 | 18 | 19 | 20 | 21 | 22 | 23 | 24 | 25 | 26 | 27 | 28 | 29 | 30 | 31 |  |  |  |  |  |  |
| OS Derived Fingerprints   | Generic List Block Length, continued           |   |   |   |   |   |   | Operating System Fingerprint Block Type (130)* |   |   |    |    |    |    |    |    |    |    |    |    |    |    |    |    |    |    |    |    |    |    |    |    |  |  |  |  |  |  |
|                           | OS Fingerprint Block Type (130)*, con't        |   |   |   |   |   |   | Operating System Fingerprint Block Length      |   |   |    |    |    |    |    |    |    |    |    |    |    |    |    |    |    |    |    |    |    |    |    |    |  |  |  |  |  |  |
|                           | OS Fingerprint Block Length, con't             |   |   |   |   |   |   | Operating System Derived Fingerprint Data...   |   |   |    |    |    |    |    |    |    |    |    |    |    |    |    |    |    |    |    |    |    |    |    |    |  |  |  |  |  |  |
|                           | Generic List Block Type (31)                   |   |   |   |   |   |   |                                                |   |   |    |    |    |    |    |    |    |    |    |    |    |    |    |    |    |    |    |    |    |    |    |    |  |  |  |  |  |  |
|                           | Generic List Block Length                      |   |   |   |   |   |   |                                                |   |   |    |    |    |    |    |    |    |    |    |    |    |    |    |    |    |    |    |    |    |    |    |    |  |  |  |  |  |  |
| Server Fingerprints       | Operating System Fingerprint Block Type (130)* |   |   |   |   |   |   |                                                |   |   |    |    |    |    |    |    |    |    |    |    |    |    |    |    |    |    |    |    |    |    |    |    |  |  |  |  |  |  |
|                           | Operating System Fingerprint Block Length      |   |   |   |   |   |   |                                                |   |   |    |    |    |    |    |    |    |    |    |    |    |    |    |    |    |    |    |    |    |    |    |    |  |  |  |  |  |  |
|                           | Operating System Server Fingerprint Data...    |   |   |   |   |   |   |                                                |   |   |    |    |    |    |    |    |    |    |    |    |    |    |    |    |    |    |    |    |    |    |    |    |  |  |  |  |  |  |
|                           | Generic List Block Type (31)                   |   |   |   |   |   |   |                                                |   |   |    |    |    |    |    |    |    |    |    |    |    |    |    |    |    |    |    |    |    |    |    |    |  |  |  |  |  |  |
|                           | Generic List Block Length                      |   |   |   |   |   |   |                                                |   |   |    |    |    |    |    |    |    |    |    |    |    |    |    |    |    |    |    |    |    |    |    |    |  |  |  |  |  |  |
| Client Fingerprints       | Operating System Fingerprint Block Type (130)* |   |   |   |   |   |   |                                                |   |   |    |    |    |    |    |    |    |    |    |    |    |    |    |    |    |    |    |    |    |    |    |    |  |  |  |  |  |  |
|                           | Operating System Fingerprint Block Length      |   |   |   |   |   |   |                                                |   |   |    |    |    |    |    |    |    |    |    |    |    |    |    |    |    |    |    |    |    |    |    |    |  |  |  |  |  |  |
|                           | Operating System Client Fingerprint Data...    |   |   |   |   |   |   |                                                |   |   |    |    |    |    |    |    |    |    |    |    |    |    |    |    |    |    |    |    |    |    |    |    |  |  |  |  |  |  |
|                           | Generic List Block Type (31)                   |   |   |   |   |   |   |                                                |   |   |    |    |    |    |    |    |    |    |    |    |    |    |    |    |    |    |    |    |    |    |    |    |  |  |  |  |  |  |
|                           | Generic List Block Length                      |   |   |   |   |   |   |                                                |   |   |    |    |    |    |    |    |    |    |    |    |    |    |    |    |    |    |    |    |    |    |    |    |  |  |  |  |  |  |
| VDB Native Fingerprints 1 | Operating System Fingerprint Block Type (130)* |   |   |   |   |   |   |                                                |   |   |    |    |    |    |    |    |    |    |    |    |    |    |    |    |    |    |    |    |    |    |    |    |  |  |  |  |  |  |
|                           | Operating System Fingerprint Block Length      |   |   |   |   |   |   |                                                |   |   |    |    |    |    |    |    |    |    |    |    |    |    |    |    |    |    |    |    |    |    |    |    |  |  |  |  |  |  |
|                           | Operating System VDB Fingerprint Data...       |   |   |   |   |   |   |                                                |   |   |    |    |    |    |    |    |    |    |    |    |    |    |    |    |    |    |    |    |    |    |    |    |  |  |  |  |  |  |
|                           | Generic List Block Type (31)                   |   |   |   |   |   |   |                                                |   |   |    |    |    |    |    |    |    |    |    |    |    |    |    |    |    |    |    |    |    |    |    |    |  |  |  |  |  |  |
|                           | Generic List Block Length                      |   |   |   |   |   |   |                                                |   |   |    |    |    |    |    |    |    |    |    |    |    |    |    |    |    |    |    |    |    |    |    |    |  |  |  |  |  |  |
| VDB Native Fingerprints 2 | Operating System Fingerprint Block Type (130)* |   |   |   |   |   |   |                                                |   |   |    |    |    |    |    |    |    |    |    |    |    |    |    |    |    |    |    |    |    |    |    |    |  |  |  |  |  |  |
|                           | Operating System Fingerprint Block Length      |   |   |   |   |   |   |                                                |   |   |    |    |    |    |    |    |    |    |    |    |    |    |    |    |    |    |    |    |    |    |    |    |  |  |  |  |  |  |
|                           | Operating System VDB Fingerprint Data...       |   |   |   |   |   |   |                                                |   |   |    |    |    |    |    |    |    |    |    |    |    |    |    |    |    |    |    |    |    |    |    |    |  |  |  |  |  |  |
|                           | Generic List Block Type (31)                   |   |   |   |   |   |   |                                                |   |   |    |    |    |    |    |    |    |    |    |    |    |    |    |    |    |    |    |    |    |    |    |    |  |  |  |  |  |  |

| Byte                     | 0                                                |   |   |   |   |   |   |   | 1 |   |    |    |    |    |    |    | 2  |    |    |    |    |    |    |    | 3  |    |    |    |    |    |    |    |
|--------------------------|--------------------------------------------------|---|---|---|---|---|---|---|---|---|----|----|----|----|----|----|----|----|----|----|----|----|----|----|----|----|----|----|----|----|----|----|
| Bit                      | 0                                                | 1 | 2 | 3 | 4 | 5 | 6 | 7 | 8 | 9 | 10 | 11 | 12 | 13 | 14 | 15 | 16 | 17 | 18 | 19 | 20 | 21 | 22 | 23 | 24 | 25 | 26 | 27 | 28 | 29 | 30 | 31 |
|                          | Generic List Block Length                        |   |   |   |   |   |   |   |   |   |    |    |    |    |    |    |    |    |    |    |    |    |    |    |    |    |    |    |    |    |    |    |
| User Fingerprints        | Operating System Fingerprint Block Type (130)*   |   |   |   |   |   |   |   |   |   |    |    |    |    |    |    |    |    |    |    |    |    |    |    |    |    |    |    |    |    |    |    |
|                          | Operating System Fingerprint Block Length        |   |   |   |   |   |   |   |   |   |    |    |    |    |    |    |    |    |    |    |    |    |    |    |    |    |    |    |    |    |    |    |
|                          | Operating System User Fingerprint Data...        |   |   |   |   |   |   |   |   |   |    |    |    |    |    |    |    |    |    |    |    |    |    |    |    |    |    |    |    |    |    |    |
|                          | Generic List Block Type (31)                     |   |   |   |   |   |   |   |   |   |    |    |    |    |    |    |    |    |    |    |    |    |    |    |    |    |    |    |    |    |    |    |
|                          | Generic List Block Length                        |   |   |   |   |   |   |   |   |   |    |    |    |    |    |    |    |    |    |    |    |    |    |    |    |    |    |    |    |    |    |    |
| Scan Fingerprints        | Operating System Fingerprint Block Type (130)*   |   |   |   |   |   |   |   |   |   |    |    |    |    |    |    |    |    |    |    |    |    |    |    |    |    |    |    |    |    |    |    |
|                          | Operating System Fingerprint Block Length        |   |   |   |   |   |   |   |   |   |    |    |    |    |    |    |    |    |    |    |    |    |    |    |    |    |    |    |    |    |    |    |
|                          | Operating System Scan Fingerprint Data...        |   |   |   |   |   |   |   |   |   |    |    |    |    |    |    |    |    |    |    |    |    |    |    |    |    |    |    |    |    |    |    |
|                          | Generic List Block Type (31)                     |   |   |   |   |   |   |   |   |   |    |    |    |    |    |    |    |    |    |    |    |    |    |    |    |    |    |    |    |    |    |    |
|                          | Generic List Block Length                        |   |   |   |   |   |   |   |   |   |    |    |    |    |    |    |    |    |    |    |    |    |    |    |    |    |    |    |    |    |    |    |
| Application Fingerprints | Operating System Fingerprint Block Type (130)*   |   |   |   |   |   |   |   |   |   |    |    |    |    |    |    |    |    |    |    |    |    |    |    |    |    |    |    |    |    |    |    |
|                          | Operating System Fingerprint Block Length        |   |   |   |   |   |   |   |   |   |    |    |    |    |    |    |    |    |    |    |    |    |    |    |    |    |    |    |    |    |    |    |
|                          | Operating System Application Fingerprint Data... |   |   |   |   |   |   |   |   |   |    |    |    |    |    |    |    |    |    |    |    |    |    |    |    |    |    |    |    |    |    |    |
|                          | Generic List Block Type (31)                     |   |   |   |   |   |   |   |   |   |    |    |    |    |    |    |    |    |    |    |    |    |    |    |    |    |    |    |    |    |    |    |
|                          | Generic List Block Length                        |   |   |   |   |   |   |   |   |   |    |    |    |    |    |    |    |    |    |    |    |    |    |    |    |    |    |    |    |    |    |    |
| Conflict Fingerprints    | Operating System Fingerprint Block Type (130)*   |   |   |   |   |   |   |   |   |   |    |    |    |    |    |    |    |    |    |    |    |    |    |    |    |    |    |    |    |    |    |    |
|                          | Operating System Fingerprint Block Length        |   |   |   |   |   |   |   |   |   |    |    |    |    |    |    |    |    |    |    |    |    |    |    |    |    |    |    |    |    |    |    |
|                          | Operating System Conflict Fingerprint Data...    |   |   |   |   |   |   |   |   |   |    |    |    |    |    |    |    |    |    |    |    |    |    |    |    |    |    |    |    |    |    |    |
| (TCP) Full Server Data   | List Block Type (11)...                          |   |   |   |   |   |   |   |   |   |    |    |    |    |    |    |    |    |    |    |    |    |    |    |    |    |    |    |    |    |    |    |
|                          | List Block Length...                             |   |   |   |   |   |   |   |   |   |    |    |    |    |    |    |    |    |    |    |    |    |    |    |    |    |    |    |    |    |    |    |
|                          | (TCP) Full Server Data Blocks (104)*             |   |   |   |   |   |   |   |   |   |    |    |    |    |    |    |    |    |    |    |    |    |    |    |    |    |    |    |    |    |    |    |
| (UDP) Full Server Data   | List Block Type (11)                             |   |   |   |   |   |   |   |   |   |    |    |    |    |    |    |    |    |    |    |    |    |    |    |    |    |    |    |    |    |    |    |
|                          | List Block Length                                |   |   |   |   |   |   |   |   |   |    |    |    |    |    |    |    |    |    |    |    |    |    |    |    |    |    |    |    |    |    |    |
|                          | (UDP) Full Server Data Blocks (104)*             |   |   |   |   |   |   |   |   |   |    |    |    |    |    |    |    |    |    |    |    |    |    |    |    |    |    |    |    |    |    |    |

| Byte                    | 0                                          |   |   |   |   |   |   |   | 1             |   |    |    |    |    |    |    | 2                                               |    |    |    |    |    |    |    | 3  |    |    |    |    |    |    |    |
|-------------------------|--------------------------------------------|---|---|---|---|---|---|---|---------------|---|----|----|----|----|----|----|-------------------------------------------------|----|----|----|----|----|----|----|----|----|----|----|----|----|----|----|
|                         | 0                                          | 1 | 2 | 3 | 4 | 5 | 6 | 7 | 8             | 9 | 10 | 11 | 12 | 13 | 14 | 15 | 16                                              | 17 | 18 | 19 | 20 | 21 | 22 | 23 | 24 | 25 | 26 | 27 | 28 | 29 | 30 | 31 |
| Network Protocol Data   | List Block Type (11)                       |   |   |   |   |   |   |   |               |   |    |    |    |    |    |    |                                                 |    |    |    |    |    |    |    |    |    |    |    |    |    |    |    |
|                         | List Block Length                          |   |   |   |   |   |   |   |               |   |    |    |    |    |    |    |                                                 |    |    |    |    |    |    |    |    |    |    |    |    |    |    |    |
|                         | (Network) Protocol Data Blocks (4)*        |   |   |   |   |   |   |   |               |   |    |    |    |    |    |    |                                                 |    |    |    |    |    |    |    |    |    |    |    |    |    |    |    |
| Transport Protocol Data | List Block Type (11)                       |   |   |   |   |   |   |   |               |   |    |    |    |    |    |    |                                                 |    |    |    |    |    |    |    |    |    |    |    |    |    |    |    |
|                         | List Block Length                          |   |   |   |   |   |   |   |               |   |    |    |    |    |    |    |                                                 |    |    |    |    |    |    |    |    |    |    |    |    |    |    |    |
|                         | (Transport) Protocol Data Blocks (4)*      |   |   |   |   |   |   |   |               |   |    |    |    |    |    |    |                                                 |    |    |    |    |    |    |    |    |    |    |    |    |    |    |    |
| MAC Address Data        | List Block Type (11)                       |   |   |   |   |   |   |   |               |   |    |    |    |    |    |    |                                                 |    |    |    |    |    |    |    |    |    |    |    |    |    |    |    |
|                         | List Block Length                          |   |   |   |   |   |   |   |               |   |    |    |    |    |    |    |                                                 |    |    |    |    |    |    |    |    |    |    |    |    |    |    |    |
|                         | Host MAC Address Data Blocks (95)*         |   |   |   |   |   |   |   |               |   |    |    |    |    |    |    |                                                 |    |    |    |    |    |    |    |    |    |    |    |    |    |    |    |
|                         | Last Seen                                  |   |   |   |   |   |   |   |               |   |    |    |    |    |    |    |                                                 |    |    |    |    |    |    |    |    |    |    |    |    |    |    |    |
|                         | Host Type                                  |   |   |   |   |   |   |   |               |   |    |    |    |    |    |    |                                                 |    |    |    |    |    |    |    |    |    |    |    |    |    |    |    |
|                         | Business Criticality                       |   |   |   |   |   |   |   |               |   |    |    |    |    |    |    | VLAN ID                                         |    |    |    |    |    |    |    |    |    |    |    |    |    |    |    |
|                         | VLAN Type                                  |   |   |   |   |   |   |   | VLAN Priority |   |    |    |    |    |    |    | Generic List Block Type (31)                    |    |    |    |    |    |    |    |    |    |    |    |    |    |    |    |
| Host Client Data        | Generic List Block Type, continued         |   |   |   |   |   |   |   |               |   |    |    |    |    |    |    | Generic List Block Length                       |    |    |    |    |    |    |    |    |    |    |    |    |    |    |    |
|                         | Generic List Block Length, continued       |   |   |   |   |   |   |   |               |   |    |    |    |    |    |    | Full Host Client Application Data Blocks (112)* |    |    |    |    |    |    |    |    |    |    |    |    |    |    |    |
| NetBIOS Name            | String Block Type (0)                      |   |   |   |   |   |   |   |               |   |    |    |    |    |    |    |                                                 |    |    |    |    |    |    |    |    |    |    |    |    |    |    |    |
|                         | String Block Length                        |   |   |   |   |   |   |   |               |   |    |    |    |    |    |    |                                                 |    |    |    |    |    |    |    |    |    |    |    |    |    |    |    |
|                         | NetBIOS Name String...                     |   |   |   |   |   |   |   |               |   |    |    |    |    |    |    |                                                 |    |    |    |    |    |    |    |    |    |    |    |    |    |    |    |
| Notes Data              | String Block Type (0)                      |   |   |   |   |   |   |   |               |   |    |    |    |    |    |    |                                                 |    |    |    |    |    |    |    |    |    |    |    |    |    |    |    |
|                         | String Block Length                        |   |   |   |   |   |   |   |               |   |    |    |    |    |    |    |                                                 |    |    |    |    |    |    |    |    |    |    |    |    |    |    |    |
|                         | Notes String....                           |   |   |   |   |   |   |   |               |   |    |    |    |    |    |    |                                                 |    |    |    |    |    |    |    |    |    |    |    |    |    |    |    |
| (VDB) Host Vulns        | Generic List Block Type (31)               |   |   |   |   |   |   |   |               |   |    |    |    |    |    |    |                                                 |    |    |    |    |    |    |    |    |    |    |    |    |    |    |    |
|                         | Generic List Block Length                  |   |   |   |   |   |   |   |               |   |    |    |    |    |    |    |                                                 |    |    |    |    |    |    |    |    |    |    |    |    |    |    |    |
|                         | (VDB) Host Vulnerability Data Blocks (85)* |   |   |   |   |   |   |   |               |   |    |    |    |    |    |    |                                                 |    |    |    |    |    |    |    |    |    |    |    |    |    |    |    |

| Byte                       | 0                                                                              |   |   |   |   |   |   |   | 1 |   |    |    |    |    |    |    | 2  |    |    |    |    |    |    |    | 3  |    |    |    |    |    |    |    |
|----------------------------|--------------------------------------------------------------------------------|---|---|---|---|---|---|---|---|---|----|----|----|----|----|----|----|----|----|----|----|----|----|----|----|----|----|----|----|----|----|----|
|                            | 0                                                                              | 1 | 2 | 3 | 4 | 5 | 6 | 7 | 8 | 9 | 10 | 11 | 12 | 13 | 14 | 15 | 16 | 17 | 18 | 19 | 20 | 21 | 22 | 23 | 24 | 25 | 26 | 27 | 28 | 29 | 30 | 31 |
| 3rd Pty/VDB)<br>Host Vulns | Generic List Block Type (31)                                                   |   |   |   |   |   |   |   |   |   |    |    |    |    |    |    |    |    |    |    |    |    |    |    |    |    |    |    |    |    |    |    |
|                            | Generic List Block Length                                                      |   |   |   |   |   |   |   |   |   |    |    |    |    |    |    |    |    |    |    |    |    |    |    |    |    |    |    |    |    |    |    |
|                            | (Third Party/VDB) Host Vulnerability Data Blocks (85)*                         |   |   |   |   |   |   |   |   |   |    |    |    |    |    |    |    |    |    |    |    |    |    |    |    |    |    |    |    |    |    |    |
| 3rd Pty Scan<br>Host Vulns | Generic List Block Type (31)                                                   |   |   |   |   |   |   |   |   |   |    |    |    |    |    |    |    |    |    |    |    |    |    |    |    |    |    |    |    |    |    |    |
|                            | Generic List Block Length                                                      |   |   |   |   |   |   |   |   |   |    |    |    |    |    |    |    |    |    |    |    |    |    |    |    |    |    |    |    |    |    |    |
|                            | (Third Party Scan) Host Vulnerability Data Blocks with Original Vuln IDs (85)* |   |   |   |   |   |   |   |   |   |    |    |    |    |    |    |    |    |    |    |    |    |    |    |    |    |    |    |    |    |    |    |
| Attribute<br>Value Data    | List Block Type (11)                                                           |   |   |   |   |   |   |   |   |   |    |    |    |    |    |    |    |    |    |    |    |    |    |    |    |    |    |    |    |    |    |    |
|                            | List Block Length                                                              |   |   |   |   |   |   |   |   |   |    |    |    |    |    |    |    |    |    |    |    |    |    |    |    |    |    |    |    |    |    |    |
|                            | Attribute Value Data Blocks *                                                  |   |   |   |   |   |   |   |   |   |    |    |    |    |    |    |    |    |    |    |    |    |    |    |    |    |    |    |    |    |    |    |

The following table describes the components of the Full Host Profile for 5.0 - 5.0.2 record.

**Table B-31 Full Host Profile Record 5.0 - 5.0.2 Fields**

| Field                                              | Data Type | Description                                                                                                                                                                                                                                                                   |
|----------------------------------------------------|-----------|-------------------------------------------------------------------------------------------------------------------------------------------------------------------------------------------------------------------------------------------------------------------------------|
| IP Address                                         | uint8[4]  | IP address of the host, in IP address octets.                                                                                                                                                                                                                                 |
| Hops                                               | uint8     | Number of network hops from the host to the device.                                                                                                                                                                                                                           |
| Generic List Block Type                            | uint32    | Initiates a Generic List data block comprising Operating System Fingerprint data blocks conveying fingerprint data derived from the existing fingerprints for the host. This value is always 31.                                                                              |
| Generic List Block Length                          | uint32    | Number of bytes in the Generic List data block, including the list header and all encapsulated Operating System Fingerprint data blocks.                                                                                                                                      |
| Operating System Derived Fingerprint Data Blocks * | variable  | Operating System Fingerprint data blocks containing information about the operating system on a host derived from the existing fingerprints for the host. See <a href="#">Operating System Fingerprint Data Block 5.1+</a> , page 4-141 for a description of this data block. |
| Generic List Block Type                            | uint32    | Initiates a Generic List data block comprising Operating System Fingerprint data blocks conveying fingerprint data identified using a server fingerprint. This value is always 31.                                                                                            |
| Generic List Block Length                          | uint32    | Number of bytes in the Generic List data block, including the list header and all encapsulated Operating System Fingerprint data blocks.                                                                                                                                      |



Table B-31 Full Host Profile Record 5.0 - 5.0.2 Fields (continued)

| Field                                                                  | Data Type | Description                                                                                                                                                                                                                                                                                           |
|------------------------------------------------------------------------|-----------|-------------------------------------------------------------------------------------------------------------------------------------------------------------------------------------------------------------------------------------------------------------------------------------------------------|
| Operating System Fingerprint (Server Fingerprint) Data Blocks *        | variable  | Operating System Fingerprint data blocks containing information about the operating system on a host identified using a server fingerprint. See <a href="#">Operating System Fingerprint Data Block 5.1+</a> , page 4-141 for a description of this data block.                                       |
| Generic List Block Type                                                | uint32    | Initiates a Generic List data block comprising Operating System Fingerprint data blocks conveying fingerprint data identified using a client fingerprint. This value is always 31.                                                                                                                    |
| Generic List Block Length                                              | uint32    | Number of bytes in the Generic List data block, including the list header and all encapsulated Operating System Fingerprint data blocks.                                                                                                                                                              |
| Operating System Fingerprint (Client Fingerprint) Data Blocks *        | variable  | Operating System Fingerprint data blocks containing information about the operating system on a host identified using a client fingerprint. See <a href="#">Operating System Fingerprint Data Block 5.1+</a> , page 4-141 for a description of this data block.                                       |
| Generic List Block Type                                                | uint32    | Initiates a Generic List data block comprising Operating System Fingerprint data blocks conveying fingerprint data identified using a Cisco VDB fingerprint. This value is always 31.                                                                                                                 |
| Generic List Block Length                                              | uint32    | Number of bytes in the Generic List data block, including the list header and all encapsulated Operating System Fingerprint data blocks.                                                                                                                                                              |
| Operating System Fingerprint (VDB) Native Fingerprint 1) Data Blocks * | variable  | Operating System Fingerprint data blocks containing information about the operating system on a host identified using the fingerprints in the Cisco vulnerability database (VDB). See <a href="#">Operating System Fingerprint Data Block 5.1+</a> , page 4-141 for a description of this data block. |
| Generic List Block Type                                                | uint32    | Initiates a Generic List data block comprising Operating System Fingerprint data blocks conveying fingerprint data identified using a Cisco VDB fingerprint. This value is always 31.                                                                                                                 |
| Generic List Block Length                                              | uint32    | Number of bytes in the Generic List data block, including the list header and all encapsulated Operating System Fingerprint data blocks.                                                                                                                                                              |
| Operating System Fingerprint (VDB) Native Fingerprint 2) Data Blocks * | variable  | Operating System Fingerprint data blocks containing information about the operating system on a host identified using the fingerprints in the Cisco vulnerability database (VDB). See <a href="#">Operating System Fingerprint Data Block 5.1+</a> , page 4-141 for a description of this data block. |
| Generic List Block Type                                                | uint32    | Initiates a Generic List data block comprising Operating System Fingerprint data blocks conveying fingerprint data added by a user. This value is always 31.                                                                                                                                          |

Table B-31 Full Host Profile Record 5.0 - 5.0.2 Fields (continued)

| Field                                                                | Data Type | Description                                                                                                                                                                                                                                                                |
|----------------------------------------------------------------------|-----------|----------------------------------------------------------------------------------------------------------------------------------------------------------------------------------------------------------------------------------------------------------------------------|
| Generic List Block Length                                            | uint32    | Number of bytes in the Generic List data block, including the list header and all encapsulated Operating System Fingerprint data blocks.                                                                                                                                   |
| Operating System Fingerprint (User Fingerprint) Data Blocks *        | variable  | Operating System Fingerprint data blocks containing information about the operating system on a host added by a user. See <a href="#">Operating System Fingerprint Data Block 5.1+</a> , page 4-141 for a description of this data block.                                  |
| Generic List Block Type                                              | uint32    | Initiates a Generic List data block comprising Operating System Fingerprint data blocks conveying fingerprint data added by a vulnerability scanner. This value is always 31.                                                                                              |
| Generic List Block Length                                            | uint32    | Number of bytes in the Generic List data block, including the list header and all encapsulated Operating System Fingerprint data blocks.                                                                                                                                   |
| Operating System Fingerprint (Scan Fingerprint) Data Blocks *        | variable  | Operating System Fingerprint data blocks containing information about the operating system on a host added by a vulnerability scanner. See <a href="#">Operating System Fingerprint Data Block 5.1+</a> , page 4-141 for a description of this data block.                 |
| Generic List Block Type                                              | uint32    | Initiates a Generic List data block comprising Operating System Fingerprint data blocks conveying fingerprint data added by an application. This value is always 31.                                                                                                       |
| Generic List Block Length                                            | uint32    | Number of bytes in the Generic List data block, including the list header and all encapsulated Operating System Fingerprint data blocks.                                                                                                                                   |
| Operating System Fingerprint (Application Fingerprint) Data Blocks * | variable  | Operating System Fingerprint data blocks containing information about the operating system on a host added by an application. See <a href="#">Operating System Fingerprint Data Block 5.1+</a> , page 4-141 for a description of this data block.                          |
| Generic List Block Type                                              | uint32    | Initiates a Generic List data block comprising Operating System Fingerprint data blocks conveying fingerprint data selected through fingerprint conflict resolution. This value is always 31.                                                                              |
| Generic List Block Length                                            | uint32    | Number of bytes in the Generic List data block, including the list header and all encapsulated Operating System Fingerprint data blocks.                                                                                                                                   |
| Operating System Fingerprint (Conflict Fingerprint) Data Blocks *    | variable  | Operating System Fingerprint data blocks containing information about the operating system on a host selected through fingerprint conflict resolution. See <a href="#">Operating System Fingerprint Data Block 5.1+</a> , page 4-141 for a description of this data block. |
| List Block Type                                                      | uint32    | Initiates a List data block comprising Full Server data blocks conveying TCP service data. This value is always 11.                                                                                                                                                        |

Table B-31 Full Host Profile Record 5.0 - 5.0.2 Fields (continued)

| Field                              | Data Type | Description                                                                                                                                                                                      |
|------------------------------------|-----------|--------------------------------------------------------------------------------------------------------------------------------------------------------------------------------------------------|
| List Block Length                  | uint32    | Number of bytes in the list. This number includes the eight bytes of the list block type and length fields, plus the length of all encapsulated Full Server data blocks.                         |
| (TCP) Full Server Data Blocks *    | variable  | List of Full Server data blocks conveying data about the TCP services on the host. See <a href="#">Full Host Server Data Block 4.10.0+</a> , page 4-122 for a description of this data block.    |
| List Block Type                    | uint32    | Initiates a List data block comprising Full Server data blocks conveying UDP service data. This value is always 11.                                                                              |
| List Block Length                  | uint32    | Number of bytes in the list. This number includes the eight bytes of the list block type and length fields, plus the length of all encapsulated Full Server data blocks.                         |
| (UDP) Full Server Data Blocks *    | variable  | List of Full Server data blocks conveying data about the UDP sub-servers on the host. See <a href="#">Full Host Server Data Block 4.10.0+</a> , page 4-122 for a description of this data block. |
| List Block Type                    | uint32    | Initiates a List data block comprising Protocol data blocks conveying network protocol data. This value is always 11.                                                                            |
| List Block Length                  | uint32    | Number of bytes in the list. This number includes the eight bytes of the list block type and length fields, plus the length of all encapsulated Protocol data blocks.                            |
| (Network) Protocol Data Blocks *   | variable  | List of Protocol data blocks conveying data about the network protocols on the host. See <a href="#">Protocol Data Block</a> , page 4-68 for a description of this data block.                   |
| List Block Type                    | uint32    | Initiates a List data block comprising Protocol data blocks conveying transport protocol data. This value is always 11.                                                                          |
| List Block Length                  | uint32    | Number of bytes in the list. This number includes the eight bytes of the list block type and length fields, plus the length of all encapsulated Protocol data blocks.                            |
| (Transport) Protocol Data Blocks * | variable  | List of Protocol data blocks conveying data about the transport protocols on the host. See <a href="#">Protocol Data Block</a> , page 4-68 for a description of this data block.                 |
| List Block Type                    | uint32    | Initiates a List data block containing Host MAC Address data blocks. This value is always 11.                                                                                                    |
| List Block Length                  | uint32    | Number of bytes in the list, including the list header and all encapsulated Host MAC Address data blocks.                                                                                        |
| Host MAC Address Data Blocks *     | variable  | List of Host MAC Address data blocks. See <a href="#">Host MAC Address 4.9+</a> , page 4-108 for a description of this data block.                                                               |
| Last Seen                          | uint32    | UNIX timestamp that represents the last time the system detected host activity.                                                                                                                  |

Table B-31 Full Host Profile Record 5.0 - 5.0.2 Fields (continued)

| Field                                      | Data Type | Description                                                                                                                                                                                                                             |
|--------------------------------------------|-----------|-----------------------------------------------------------------------------------------------------------------------------------------------------------------------------------------------------------------------------------------|
| Host Type                                  | uint32    | Indicates host type. Values include: <ul style="list-style-type: none"> <li>• 0 - host</li> <li>• 1 - router</li> <li>• 2 - bridge</li> <li>• 3 - NAT (network address translation device)</li> <li>• 4 - LB (load balancer)</li> </ul> |
| Business Criticality                       | uint16    | Indicates criticality of host to business.                                                                                                                                                                                              |
| VLAN ID                                    | uint16    | VLAN identification number that indicates which VLAN the host is a member of.                                                                                                                                                           |
| VLAN Type                                  | uint8     | Type of packet encapsulated in the VLAN tag.                                                                                                                                                                                            |
| VLAN Priority                              | uint8     | Priority value included in the VLAN tag.                                                                                                                                                                                                |
| Generic List Block Type                    | uint32    | Initiates a Generic List data block comprising Host Vulnerability data blocks conveying Client Application data. This value is always 31.                                                                                               |
| Generic List Block Length                  | uint32    | Number of bytes in the Generic List data block, including the list header and all encapsulated Client Application data blocks.                                                                                                          |
| Full Host Client Application Data Blocks * | variable  | List of Client Application data blocks. See <a href="#">Full Host Client Application Data Block 5.0+</a> , page 4-136 for a description of this data block.                                                                             |
| String Block Type                          | uint32    | Initiates a String data block for the host NetBIOS name. This value is always 0.                                                                                                                                                        |
| String Block Length                        | uint32    | Number of bytes in the String data block, including eight bytes for the string block type and length fields, plus the number of bytes in the NetBIOS name string.                                                                       |
| NetBIOS Name                               | string    | Host NetBIOS name string.                                                                                                                                                                                                               |
| String Block Type                          | uint32    | Initiates a String data block for host notes. This value is always 0.                                                                                                                                                                   |
| String Block Length                        | uint32    | Number of bytes in the notes String data block, including eight bytes for the string block type and length fields, plus the number of bytes in the notes string.                                                                        |
| Notes                                      | string    | Contains the contents of the Notes host attribute for the host.                                                                                                                                                                         |
| Generic List Block Type                    | uint32    | Initiates a Generic List data block comprising Host Vulnerability data blocks conveying VDB vulnerability data. This value is always 31.                                                                                                |
| Generic List Block Length                  | uint32    | Number of bytes in the Generic List data block, including the list header and all encapsulated data blocks.                                                                                                                             |
| (VDB) Host Vulnerability Data Blocks *     | variable  | List of Host Vulnerability data blocks for vulnerabilities identified in the Cisco vulnerability database (VDB). See <a href="#">Host Vulnerability Data Block 4.9.0+</a> , page 4-105 for a description of this data block.            |
| Generic List Block Type                    | uint32    | Initiates a Generic List data block comprising Host Vulnerability data blocks conveying third-party scan vulnerability data. This value is always 31.                                                                                   |

Table B-31 Full Host Profile Record 5.0 - 5.0.2 Fields (continued)

| Field                                               | Data Type | Description                                                                                                                                                                                                                                                                                       |
|-----------------------------------------------------|-----------|---------------------------------------------------------------------------------------------------------------------------------------------------------------------------------------------------------------------------------------------------------------------------------------------------|
| Generic List Block Length                           | uint32    | Number of bytes in the Generic List data block, including the list header and all encapsulated data blocks.                                                                                                                                                                                       |
| (Third Party/VDB) Host Vulnerability Data Blocks *  | variable  | Host Vulnerability data blocks sourced from a third party scanner and containing information about host vulnerabilities cataloged in the Cisco vulnerability database (VDB). See <a href="#">Host Vulnerability Data Block 4.9.0+, page 4-105</a> for a description of this data block.           |
| Generic List Block Type                             | uint32    | Initiates a Generic List data block comprising Host Vulnerability data blocks conveying third party scan vulnerability data. This value is always 31.                                                                                                                                             |
| Generic List Block Length                           | uint32    | Number of bytes in the Generic List data block, including the list header and all encapsulated data blocks.                                                                                                                                                                                       |
| (Third Party Scan) Host Vulnerability Data Blocks * | variable  | Host Vulnerability data blocks sourced from a third party scanner. Note that the host vulnerability IDs for these data blocks are the third party scanner IDs, not Cisco-detected IDs. See <a href="#">Host Vulnerability Data Block 4.9.0+, page 4-105</a> for a description of this data block. |
| List Block Type                                     | uint32    | Initiates a List data block comprising Attribute Value data blocks conveying attribute data. This value is always 11.                                                                                                                                                                             |
| List Block Length                                   | uint32    | Number of bytes in the List data block, including the list header and all encapsulated data blocks.                                                                                                                                                                                               |
| Attribute Value Data Blocks *                       | variable  | List of Attribute Value data blocks. See <a href="#">Attribute Value Data Block, page 4-75</a> for a description of the data blocks in this list.                                                                                                                                                 |

## Full Host Profile Data Block 5.1.1

The Full Host Profile data block for version 5.1.1 contains a full set of data describing one host. It has the format shown in the graphic below and explained in the following table. Note that, except for List data blocks, the graphic does not show the fields of the encapsulated data blocks. These encapsulated data blocks are described separately in [Understanding Discovery & Connection Data Structures, page 4-1](#). The Full Host Profile data block a block type value of 135. It deprecates data block 111.



Note

An asterisk(\*) next to a block name in the following diagram indicates that multiple instances of the data block may occur.

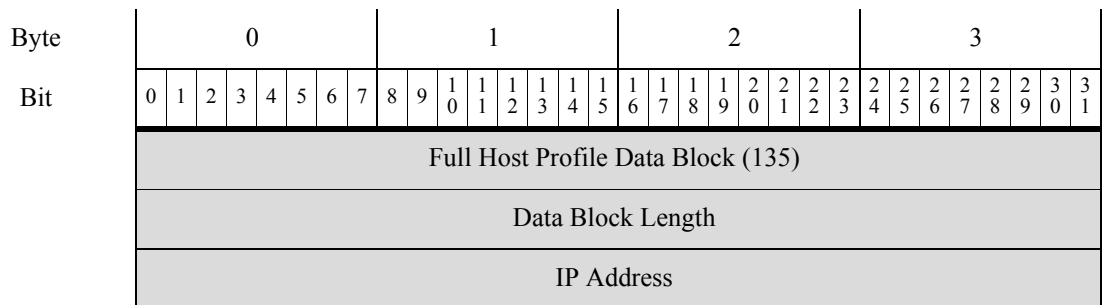

| Byte                      | 0                                              |   |   |   |   |   |   |   | 1                                              |   |    |    |    |    |    |    | 2  |    |    |    |    |    |    |    | 3  |    |    |    |    |    |    |    |  |  |  |  |  |  |  |
|---------------------------|------------------------------------------------|---|---|---|---|---|---|---|------------------------------------------------|---|----|----|----|----|----|----|----|----|----|----|----|----|----|----|----|----|----|----|----|----|----|----|--|--|--|--|--|--|--|
| Bit                       | 0                                              | 1 | 2 | 3 | 4 | 5 | 6 | 7 | 8                                              | 9 | 10 | 11 | 12 | 13 | 14 | 15 | 16 | 17 | 18 | 19 | 20 | 21 | 22 | 23 | 24 | 25 | 26 | 27 | 28 | 29 | 30 | 31 |  |  |  |  |  |  |  |
|                           | Hops                                           |   |   |   |   |   |   |   | Generic List Block Type (31)                   |   |    |    |    |    |    |    |    |    |    |    |    |    |    |    |    |    |    |    |    |    |    |    |  |  |  |  |  |  |  |
|                           | Generic List Block Type, continued             |   |   |   |   |   |   |   | Generic List Block Length                      |   |    |    |    |    |    |    |    |    |    |    |    |    |    |    |    |    |    |    |    |    |    |    |  |  |  |  |  |  |  |
| OS Derived Fingerprints   | Generic List Block Length, continued           |   |   |   |   |   |   |   | Operating System Fingerprint Block Type (130)* |   |    |    |    |    |    |    |    |    |    |    |    |    |    |    |    |    |    |    |    |    |    |    |  |  |  |  |  |  |  |
|                           | OS Fingerprint Block Type (130)*, con't        |   |   |   |   |   |   |   | Operating System Fingerprint Block Length      |   |    |    |    |    |    |    |    |    |    |    |    |    |    |    |    |    |    |    |    |    |    |    |  |  |  |  |  |  |  |
|                           | OS Fingerprint Block Length, con't             |   |   |   |   |   |   |   | Operating System Derived Fingerprint Data...   |   |    |    |    |    |    |    |    |    |    |    |    |    |    |    |    |    |    |    |    |    |    |    |  |  |  |  |  |  |  |
|                           | Generic List Block Type (31)                   |   |   |   |   |   |   |   |                                                |   |    |    |    |    |    |    |    |    |    |    |    |    |    |    |    |    |    |    |    |    |    |    |  |  |  |  |  |  |  |
|                           | Generic List Block Length                      |   |   |   |   |   |   |   |                                                |   |    |    |    |    |    |    |    |    |    |    |    |    |    |    |    |    |    |    |    |    |    |    |  |  |  |  |  |  |  |
| Server Fingerprints       | Operating System Fingerprint Block Type (130)* |   |   |   |   |   |   |   |                                                |   |    |    |    |    |    |    |    |    |    |    |    |    |    |    |    |    |    |    |    |    |    |    |  |  |  |  |  |  |  |
|                           | Operating System Fingerprint Block Length      |   |   |   |   |   |   |   |                                                |   |    |    |    |    |    |    |    |    |    |    |    |    |    |    |    |    |    |    |    |    |    |    |  |  |  |  |  |  |  |
|                           | Operating System Server Fingerprint Data...    |   |   |   |   |   |   |   |                                                |   |    |    |    |    |    |    |    |    |    |    |    |    |    |    |    |    |    |    |    |    |    |    |  |  |  |  |  |  |  |
|                           | Generic List Block Type (31)                   |   |   |   |   |   |   |   |                                                |   |    |    |    |    |    |    |    |    |    |    |    |    |    |    |    |    |    |    |    |    |    |    |  |  |  |  |  |  |  |
|                           | Generic List Block Length                      |   |   |   |   |   |   |   |                                                |   |    |    |    |    |    |    |    |    |    |    |    |    |    |    |    |    |    |    |    |    |    |    |  |  |  |  |  |  |  |
| Client Fingerprints       | Operating System Fingerprint Block Type (130)* |   |   |   |   |   |   |   |                                                |   |    |    |    |    |    |    |    |    |    |    |    |    |    |    |    |    |    |    |    |    |    |    |  |  |  |  |  |  |  |
|                           | Operating System Fingerprint Block Length      |   |   |   |   |   |   |   |                                                |   |    |    |    |    |    |    |    |    |    |    |    |    |    |    |    |    |    |    |    |    |    |    |  |  |  |  |  |  |  |
|                           | Operating System Client Fingerprint Data...    |   |   |   |   |   |   |   |                                                |   |    |    |    |    |    |    |    |    |    |    |    |    |    |    |    |    |    |    |    |    |    |    |  |  |  |  |  |  |  |
|                           | Generic List Block Type (31)                   |   |   |   |   |   |   |   |                                                |   |    |    |    |    |    |    |    |    |    |    |    |    |    |    |    |    |    |    |    |    |    |    |  |  |  |  |  |  |  |
|                           | Generic List Block Length                      |   |   |   |   |   |   |   |                                                |   |    |    |    |    |    |    |    |    |    |    |    |    |    |    |    |    |    |    |    |    |    |    |  |  |  |  |  |  |  |
| VDB Native Fingerprints 1 | Operating System Fingerprint Block Type (130)* |   |   |   |   |   |   |   |                                                |   |    |    |    |    |    |    |    |    |    |    |    |    |    |    |    |    |    |    |    |    |    |    |  |  |  |  |  |  |  |
|                           | Operating System Fingerprint Block Length      |   |   |   |   |   |   |   |                                                |   |    |    |    |    |    |    |    |    |    |    |    |    |    |    |    |    |    |    |    |    |    |    |  |  |  |  |  |  |  |
|                           | Operating System VDB Fingerprint Data...       |   |   |   |   |   |   |   |                                                |   |    |    |    |    |    |    |    |    |    |    |    |    |    |    |    |    |    |    |    |    |    |    |  |  |  |  |  |  |  |
|                           | Generic List Block Type (31)                   |   |   |   |   |   |   |   |                                                |   |    |    |    |    |    |    |    |    |    |    |    |    |    |    |    |    |    |    |    |    |    |    |  |  |  |  |  |  |  |
|                           | Generic List Block Length                      |   |   |   |   |   |   |   |                                                |   |    |    |    |    |    |    |    |    |    |    |    |    |    |    |    |    |    |    |    |    |    |    |  |  |  |  |  |  |  |

| Byte                      | 0                                                |   |   |   |   |   |   |   | 1 |   |    |    |    |    |    |    | 2  |    |    |    |    |    |    |    | 3  |    |    |    |    |    |    |    |
|---------------------------|--------------------------------------------------|---|---|---|---|---|---|---|---|---|----|----|----|----|----|----|----|----|----|----|----|----|----|----|----|----|----|----|----|----|----|----|
|                           | 0                                                | 1 | 2 | 3 | 4 | 5 | 6 | 7 | 8 | 9 | 10 | 11 | 12 | 13 | 14 | 15 | 16 | 17 | 18 | 19 | 20 | 21 | 22 | 23 | 24 | 25 | 26 | 27 | 28 | 29 | 30 | 31 |
| VDB Native Fingerprints 2 | Operating System Fingerprint Block Type (130)*   |   |   |   |   |   |   |   |   |   |    |    |    |    |    |    |    |    |    |    |    |    |    |    |    |    |    |    |    |    |    |    |
|                           | Operating System Fingerprint Block Length        |   |   |   |   |   |   |   |   |   |    |    |    |    |    |    |    |    |    |    |    |    |    |    |    |    |    |    |    |    |    |    |
|                           | Operating System VDB Fingerprint Data...         |   |   |   |   |   |   |   |   |   |    |    |    |    |    |    |    |    |    |    |    |    |    |    |    |    |    |    |    |    |    |    |
|                           | Generic List Block Type (31)                     |   |   |   |   |   |   |   |   |   |    |    |    |    |    |    |    |    |    |    |    |    |    |    |    |    |    |    |    |    |    |    |
|                           | Generic List Block Length                        |   |   |   |   |   |   |   |   |   |    |    |    |    |    |    |    |    |    |    |    |    |    |    |    |    |    |    |    |    |    |    |
| User Fingerprints         | Operating System Fingerprint Block Type (130)*   |   |   |   |   |   |   |   |   |   |    |    |    |    |    |    |    |    |    |    |    |    |    |    |    |    |    |    |    |    |    |    |
|                           | Operating System Fingerprint Block Length        |   |   |   |   |   |   |   |   |   |    |    |    |    |    |    |    |    |    |    |    |    |    |    |    |    |    |    |    |    |    |    |
|                           | Operating System User Fingerprint Data...        |   |   |   |   |   |   |   |   |   |    |    |    |    |    |    |    |    |    |    |    |    |    |    |    |    |    |    |    |    |    |    |
|                           | Generic List Block Type (31)                     |   |   |   |   |   |   |   |   |   |    |    |    |    |    |    |    |    |    |    |    |    |    |    |    |    |    |    |    |    |    |    |
|                           | Generic List Block Length                        |   |   |   |   |   |   |   |   |   |    |    |    |    |    |    |    |    |    |    |    |    |    |    |    |    |    |    |    |    |    |    |
| Scan Fingerprints         | Operating System Fingerprint Block Type (130)*   |   |   |   |   |   |   |   |   |   |    |    |    |    |    |    |    |    |    |    |    |    |    |    |    |    |    |    |    |    |    |    |
|                           | Operating System Fingerprint Block Length        |   |   |   |   |   |   |   |   |   |    |    |    |    |    |    |    |    |    |    |    |    |    |    |    |    |    |    |    |    |    |    |
|                           | Operating System Scan Fingerprint Data...        |   |   |   |   |   |   |   |   |   |    |    |    |    |    |    |    |    |    |    |    |    |    |    |    |    |    |    |    |    |    |    |
|                           | Generic List Block Type (31)                     |   |   |   |   |   |   |   |   |   |    |    |    |    |    |    |    |    |    |    |    |    |    |    |    |    |    |    |    |    |    |    |
|                           | Generic List Block Length                        |   |   |   |   |   |   |   |   |   |    |    |    |    |    |    |    |    |    |    |    |    |    |    |    |    |    |    |    |    |    |    |
| Application Fingerprints  | Operating System Fingerprint Block Type (130)*   |   |   |   |   |   |   |   |   |   |    |    |    |    |    |    |    |    |    |    |    |    |    |    |    |    |    |    |    |    |    |    |
|                           | Operating System Fingerprint Block Length        |   |   |   |   |   |   |   |   |   |    |    |    |    |    |    |    |    |    |    |    |    |    |    |    |    |    |    |    |    |    |    |
|                           | Operating System Application Fingerprint Data... |   |   |   |   |   |   |   |   |   |    |    |    |    |    |    |    |    |    |    |    |    |    |    |    |    |    |    |    |    |    |    |
|                           | Generic List Block Type (31)                     |   |   |   |   |   |   |   |   |   |    |    |    |    |    |    |    |    |    |    |    |    |    |    |    |    |    |    |    |    |    |    |
|                           | Generic List Block Length                        |   |   |   |   |   |   |   |   |   |    |    |    |    |    |    |    |    |    |    |    |    |    |    |    |    |    |    |    |    |    |    |
| Conflict Fingerprints     | Operating System Fingerprint Block Type (130)*   |   |   |   |   |   |   |   |   |   |    |    |    |    |    |    |    |    |    |    |    |    |    |    |    |    |    |    |    |    |    |    |
|                           | Operating System Fingerprint Block Length        |   |   |   |   |   |   |   |   |   |    |    |    |    |    |    |    |    |    |    |    |    |    |    |    |    |    |    |    |    |    |    |
|                           | Operating System Conflict Fingerprint Data...    |   |   |   |   |   |   |   |   |   |    |    |    |    |    |    |    |    |    |    |    |    |    |    |    |    |    |    |    |    |    |    |
| (TCP) Full Server Data    | List Block Type (11)...                          |   |   |   |   |   |   |   |   |   |    |    |    |    |    |    |    |    |    |    |    |    |    |    |    |    |    |    |    |    |    |    |
|                           | List Block Length...                             |   |   |   |   |   |   |   |   |   |    |    |    |    |    |    |    |    |    |    |    |    |    |    |    |    |    |    |    |    |    |    |
|                           | (TCP) Full Server Data Blocks (104)*             |   |   |   |   |   |   |   |   |   |    |    |    |    |    |    |    |    |    |    |    |    |    |    |    |    |    |    |    |    |    |    |

| Byte                    | 0                                     |   |   |   |   |   |   |               | 1 |   |    |    |    |    |    |                              | 2                                               |    |    |    |    |    |    |    | 3  |    |    |    |    |    |    |    |
|-------------------------|---------------------------------------|---|---|---|---|---|---|---------------|---|---|----|----|----|----|----|------------------------------|-------------------------------------------------|----|----|----|----|----|----|----|----|----|----|----|----|----|----|----|
|                         | 0                                     | 1 | 2 | 3 | 4 | 5 | 6 | 7             | 8 | 9 | 10 | 11 | 12 | 13 | 14 | 15                           | 16                                              | 17 | 18 | 19 | 20 | 21 | 22 | 23 | 24 | 25 | 26 | 27 | 28 | 29 | 30 | 31 |
| (UDP) Full Server Data  | List Block Type (11)                  |   |   |   |   |   |   |               |   |   |    |    |    |    |    |                              |                                                 |    |    |    |    |    |    |    |    |    |    |    |    |    |    |    |
|                         | List Block Length                     |   |   |   |   |   |   |               |   |   |    |    |    |    |    |                              |                                                 |    |    |    |    |    |    |    |    |    |    |    |    |    |    |    |
|                         | (UDP) Full Server Data Blocks (104)*  |   |   |   |   |   |   |               |   |   |    |    |    |    |    |                              |                                                 |    |    |    |    |    |    |    |    |    |    |    |    |    |    |    |
| Network Protocol Data   | List Block Type (11)                  |   |   |   |   |   |   |               |   |   |    |    |    |    |    |                              |                                                 |    |    |    |    |    |    |    |    |    |    |    |    |    |    |    |
|                         | List Block Length                     |   |   |   |   |   |   |               |   |   |    |    |    |    |    |                              |                                                 |    |    |    |    |    |    |    |    |    |    |    |    |    |    |    |
|                         | (Network) Protocol Data Blocks (4)*   |   |   |   |   |   |   |               |   |   |    |    |    |    |    |                              |                                                 |    |    |    |    |    |    |    |    |    |    |    |    |    |    |    |
| Transport Protocol Data | List Block Type (11)                  |   |   |   |   |   |   |               |   |   |    |    |    |    |    |                              |                                                 |    |    |    |    |    |    |    |    |    |    |    |    |    |    |    |
|                         | List Block Length                     |   |   |   |   |   |   |               |   |   |    |    |    |    |    |                              |                                                 |    |    |    |    |    |    |    |    |    |    |    |    |    |    |    |
|                         | (Transport) Protocol Data Blocks (4)* |   |   |   |   |   |   |               |   |   |    |    |    |    |    |                              |                                                 |    |    |    |    |    |    |    |    |    |    |    |    |    |    |    |
| MAC Address Data        | List Block Type (11)                  |   |   |   |   |   |   |               |   |   |    |    |    |    |    |                              |                                                 |    |    |    |    |    |    |    |    |    |    |    |    |    |    |    |
|                         | List Block Length                     |   |   |   |   |   |   |               |   |   |    |    |    |    |    |                              |                                                 |    |    |    |    |    |    |    |    |    |    |    |    |    |    |    |
|                         | Host MAC Address Data Blocks (95)*    |   |   |   |   |   |   |               |   |   |    |    |    |    |    |                              |                                                 |    |    |    |    |    |    |    |    |    |    |    |    |    |    |    |
| Last Seen               |                                       |   |   |   |   |   |   |               |   |   |    |    |    |    |    |                              |                                                 |    |    |    |    |    |    |    |    |    |    |    |    |    |    |    |
| Host Type               |                                       |   |   |   |   |   |   |               |   |   |    |    |    |    |    |                              |                                                 |    |    |    |    |    |    |    |    |    |    |    |    |    |    |    |
| Business Criticality    |                                       |   |   |   |   |   |   |               |   |   |    |    |    |    |    | VLAN ID                      |                                                 |    |    |    |    |    |    |    |    |    |    |    |    |    |    |    |
| VLAN Type               |                                       |   |   |   |   |   |   | VLAN Priority |   |   |    |    |    |    |    | Generic List Block Type (31) |                                                 |    |    |    |    |    |    |    |    |    |    |    |    |    |    |    |
| Host Client Data        | Generic List Block Type, continued    |   |   |   |   |   |   |               |   |   |    |    |    |    |    |                              | Generic List Block Length                       |    |    |    |    |    |    |    |    |    |    |    |    |    |    |    |
|                         | Generic List Block Length, continued  |   |   |   |   |   |   |               |   |   |    |    |    |    |    |                              | Full Host Client Application Data Blocks (112)* |    |    |    |    |    |    |    |    |    |    |    |    |    |    |    |
| NetBIOS Name            | String Block Type (0)                 |   |   |   |   |   |   |               |   |   |    |    |    |    |    |                              |                                                 |    |    |    |    |    |    |    |    |    |    |    |    |    |    |    |
|                         | String Block Length                   |   |   |   |   |   |   |               |   |   |    |    |    |    |    |                              |                                                 |    |    |    |    |    |    |    |    |    |    |    |    |    |    |    |
|                         | NetBIOS Name String...                |   |   |   |   |   |   |               |   |   |    |    |    |    |    |                              |                                                 |    |    |    |    |    |    |    |    |    |    |    |    |    |    |    |
| Notes Data              | String Block Type (0)                 |   |   |   |   |   |   |               |   |   |    |    |    |    |    |                              |                                                 |    |    |    |    |    |    |    |    |    |    |    |    |    |    |    |
|                         | String Block Length                   |   |   |   |   |   |   |               |   |   |    |    |    |    |    |                              |                                                 |    |    |    |    |    |    |    |    |    |    |    |    |    |    |    |
|                         | Notes String....                      |   |   |   |   |   |   |               |   |   |    |    |    |    |    |                              |                                                 |    |    |    |    |    |    |    |    |    |    |    |    |    |    |    |



| Byte                    | 0                                                                              |   |   |   |   |   |   |            | 1 |   |    |    |    |    |    |               | 2  |    |    |    |    |    |    |    | 3  |    |    |    |    |    |    |    |
|-------------------------|--------------------------------------------------------------------------------|---|---|---|---|---|---|------------|---|---|----|----|----|----|----|---------------|----|----|----|----|----|----|----|----|----|----|----|----|----|----|----|----|
|                         | 0                                                                              | 1 | 2 | 3 | 4 | 5 | 6 | 7          | 8 | 9 | 10 | 11 | 12 | 13 | 14 | 15            | 16 | 17 | 18 | 19 | 20 | 21 | 22 | 23 | 24 | 25 | 26 | 27 | 28 | 29 | 30 | 31 |
| (VDB) Host Vulns        | Generic List Block Type (31)                                                   |   |   |   |   |   |   |            |   |   |    |    |    |    |    |               |    |    |    |    |    |    |    |    |    |    |    |    |    |    |    |    |
|                         | Generic List Block Length                                                      |   |   |   |   |   |   |            |   |   |    |    |    |    |    |               |    |    |    |    |    |    |    |    |    |    |    |    |    |    |    |    |
|                         | (VDB) Host Vulnerability Data Blocks (85)*                                     |   |   |   |   |   |   |            |   |   |    |    |    |    |    |               |    |    |    |    |    |    |    |    |    |    |    |    |    |    |    |    |
| 3rd Pty/VDB) Host Vulns | Generic List Block Type (31)                                                   |   |   |   |   |   |   |            |   |   |    |    |    |    |    |               |    |    |    |    |    |    |    |    |    |    |    |    |    |    |    |    |
|                         | Generic List Block Length                                                      |   |   |   |   |   |   |            |   |   |    |    |    |    |    |               |    |    |    |    |    |    |    |    |    |    |    |    |    |    |    |    |
|                         | (Third Party/VDB) Host Vulnerability Data Blocks (85)*                         |   |   |   |   |   |   |            |   |   |    |    |    |    |    |               |    |    |    |    |    |    |    |    |    |    |    |    |    |    |    |    |
| 3rd Pty Scan Host Vulns | Generic List Block Type (31)                                                   |   |   |   |   |   |   |            |   |   |    |    |    |    |    |               |    |    |    |    |    |    |    |    |    |    |    |    |    |    |    |    |
|                         | Generic List Block Length                                                      |   |   |   |   |   |   |            |   |   |    |    |    |    |    |               |    |    |    |    |    |    |    |    |    |    |    |    |    |    |    |    |
|                         | (Third Party Scan) Host Vulnerability Data Blocks with Original Vuln IDs (85)* |   |   |   |   |   |   |            |   |   |    |    |    |    |    |               |    |    |    |    |    |    |    |    |    |    |    |    |    |    |    |    |
| Attribute Value Data    | List Block Type (11)                                                           |   |   |   |   |   |   |            |   |   |    |    |    |    |    |               |    |    |    |    |    |    |    |    |    |    |    |    |    |    |    |    |
|                         | List Block Length                                                              |   |   |   |   |   |   |            |   |   |    |    |    |    |    |               |    |    |    |    |    |    |    |    |    |    |    |    |    |    |    |    |
|                         | Attribute Value Data Blocks *                                                  |   |   |   |   |   |   |            |   |   |    |    |    |    |    |               |    |    |    |    |    |    |    |    |    |    |    |    |    |    |    |    |
| Mobile                  |                                                                                |   |   |   |   |   |   | Jailbroken |   |   |    |    |    |    |    | VLAN Presence |    |    |    |    |    |    |    |    |    |    |    |    |    |    |    |    |

The following table describes the components of the Full Host Profile for 5.1.1 record.

**Table B-32 Full Host Profile Record 5.1.1 Fields**

| Field                                              | Data Type | Description                                                                                                                                                                                                                                                                   |
|----------------------------------------------------|-----------|-------------------------------------------------------------------------------------------------------------------------------------------------------------------------------------------------------------------------------------------------------------------------------|
| IP Address                                         | uint8[4]  | IP address of the host, in IP address octets.                                                                                                                                                                                                                                 |
| Hops                                               | uint8     | Number of network hops from the host to the device.                                                                                                                                                                                                                           |
| Generic List Block Type                            | uint32    | Initiates a Generic List data block comprising Operating System Fingerprint data blocks conveying fingerprint data derived from the existing fingerprints for the host. This value is always 31.                                                                              |
| Generic List Block Length                          | uint32    | Number of bytes in the Generic List data block, including the list header and all encapsulated Operating System Fingerprint data blocks.                                                                                                                                      |
| Operating System Derived Fingerprint Data Blocks * | variable  | Operating System Fingerprint data blocks containing information about the operating system on a host derived from the existing fingerprints for the host. See <a href="#">Operating System Fingerprint Data Block 5.1+</a> , page 4-141 for a description of this data block. |
| Generic List Block Type                            | uint32    | Initiates a Generic List data block comprising Operating System Fingerprint data blocks conveying fingerprint data identified using a server fingerprint. This value is always 31.                                                                                            |
| Generic List Block Length                          | uint32    | Number of bytes in the Generic List data block, including the list header and all encapsulated Operating System Fingerprint data blocks.                                                                                                                                      |

Table B-32 Full Host Profile Record 5.1.1 Fields (continued)

| Field                                                                  | Data Type | Description                                                                                                                                                                                                                                                                                           |
|------------------------------------------------------------------------|-----------|-------------------------------------------------------------------------------------------------------------------------------------------------------------------------------------------------------------------------------------------------------------------------------------------------------|
| Operating System Fingerprint (Server Fingerprint) Data Blocks *        | variable  | Operating System Fingerprint data blocks containing information about the operating system on a host identified using a server fingerprint. See <a href="#">Operating System Fingerprint Data Block 5.1+</a> , page 4-141 for a description of this data block.                                       |
| Generic List Block Type                                                | uint32    | Initiates a Generic List data block comprising Operating System Fingerprint data blocks conveying fingerprint data identified using a client fingerprint. This value is always 31.                                                                                                                    |
| Generic List Block Length                                              | uint32    | Number of bytes in the Generic List data block, including the list header and all encapsulated Operating System Fingerprint data blocks.                                                                                                                                                              |
| Operating System Fingerprint (Client Fingerprint) Data Blocks *        | variable  | Operating System Fingerprint data blocks containing information about the operating system on a host identified using a client fingerprint. See <a href="#">Operating System Fingerprint Data Block 5.1+</a> , page 4-141 for a description of this data block.                                       |
| Generic List Block Type                                                | uint32    | Initiates a Generic List data block comprising Operating System Fingerprint data blocks conveying fingerprint data identified using a Cisco VDB fingerprint. This value is always 31.                                                                                                                 |
| Generic List Block Length                                              | uint32    | Number of bytes in the Generic List data block, including the list header and all encapsulated Operating System Fingerprint data blocks.                                                                                                                                                              |
| Operating System Fingerprint (VDB) Native Fingerprint 1) Data Blocks * | variable  | Operating System Fingerprint data blocks containing information about the operating system on a host identified using the fingerprints in the Cisco vulnerability database (VDB). See <a href="#">Operating System Fingerprint Data Block 5.1+</a> , page 4-141 for a description of this data block. |
| Generic List Block Type                                                | uint32    | Initiates a Generic List data block comprising Operating System Fingerprint data blocks conveying fingerprint data identified using a Cisco VDB fingerprint. This value is always 31.                                                                                                                 |
| Generic List Block Length                                              | uint32    | Number of bytes in the Generic List data block, including the list header and all encapsulated Operating System Fingerprint data blocks.                                                                                                                                                              |
| Operating System Fingerprint (VDB) Native Fingerprint 2) Data Blocks * | variable  | Operating System Fingerprint data blocks containing information about the operating system on a host identified using the fingerprints in the Cisco vulnerability database (VDB). See <a href="#">Operating System Fingerprint Data Block 5.1+</a> , page 4-141 for a description of this data block. |
| Generic List Block Type                                                | uint32    | Initiates a Generic List data block comprising Operating System Fingerprint data blocks conveying fingerprint data added by a user. This value is always 31.                                                                                                                                          |
| Generic List Block Length                                              | uint32    | Number of bytes in the Generic List data block, including the list header and all encapsulated Operating System Fingerprint data blocks.                                                                                                                                                              |

Table B-32 Full Host Profile Record 5.1.1 Fields (continued)

| Field                                                                | Data Type | Description                                                                                                                                                                                                                                                                |
|----------------------------------------------------------------------|-----------|----------------------------------------------------------------------------------------------------------------------------------------------------------------------------------------------------------------------------------------------------------------------------|
| Operating System Fingerprint (User Fingerprint) Data Blocks *        | variable  | Operating System Fingerprint data blocks containing information about the operating system on a host added by a user. See <a href="#">Operating System Fingerprint Data Block 5.1+</a> , page 4-141 for a description of this data block.                                  |
| Generic List Block Type                                              | uint32    | Initiates a Generic List data block comprising Operating System Fingerprint data blocks conveying fingerprint data added by a vulnerability scanner. This value is always 31.                                                                                              |
| Generic List Block Length                                            | uint32    | Number of bytes in the Generic List data block, including the list header and all encapsulated Operating System Fingerprint data blocks.                                                                                                                                   |
| Operating System Fingerprint (Scan Fingerprint) Data Blocks *        | variable  | Operating System Fingerprint data blocks containing information about the operating system on a host added by a vulnerability scanner. See <a href="#">Operating System Fingerprint Data Block 5.1+</a> , page 4-141 for a description of this data block.                 |
| Generic List Block Type                                              | uint32    | Initiates a Generic List data block comprising Operating System Fingerprint data blocks conveying fingerprint data added by an application. This value is always 31.                                                                                                       |
| Generic List Block Length                                            | uint32    | Number of bytes in the Generic List data block, including the list header and all encapsulated Operating System Fingerprint data blocks.                                                                                                                                   |
| Operating System Fingerprint (Application Fingerprint) Data Blocks * | variable  | Operating System Fingerprint data blocks containing information about the operating system on a host added by an application. See <a href="#">Operating System Fingerprint Data Block 5.1+</a> , page 4-141 for a description of this data block.                          |
| Generic List Block Type                                              | uint32    | Initiates a Generic List data block comprising Operating System Fingerprint data blocks conveying fingerprint data selected through fingerprint conflict resolution. This value is always 31.                                                                              |
| Generic List Block Length                                            | uint32    | Number of bytes in the Generic List data block, including the list header and all encapsulated Operating System Fingerprint data blocks.                                                                                                                                   |
| Operating System Fingerprint (Conflict Fingerprint) Data Blocks *    | variable  | Operating System Fingerprint data blocks containing information about the operating system on a host selected through fingerprint conflict resolution. See <a href="#">Operating System Fingerprint Data Block 5.1+</a> , page 4-141 for a description of this data block. |
| List Block Type                                                      | uint32    | Initiates a List data block comprising Full Server data blocks conveying TCP service data. This value is always 11.                                                                                                                                                        |
| List Block Length                                                    | uint32    | Number of bytes in the list. This number includes the eight bytes of the list block type and length fields, plus the length of all encapsulated Full Server data blocks.                                                                                                   |
| (TCP) Full Server Data Blocks *                                      | variable  | List of Full Server data blocks conveying data about the TCP services on the host. See <a href="#">Full Host Server Data Block 4.10.0+</a> , page 4-122 for a description of this data block.                                                                              |

Table B-32 Full Host Profile Record 5.1.1 Fields (continued)

| Field                              | Data Type | Description                                                                                                                                                                                                                             |
|------------------------------------|-----------|-----------------------------------------------------------------------------------------------------------------------------------------------------------------------------------------------------------------------------------------|
| List Block Type                    | uint32    | Initiates a List data block comprising Full Server data blocks conveying UDP service data. This value is always 11.                                                                                                                     |
| List Block Length                  | uint32    | Number of bytes in the list. This number includes the eight bytes of the list block type and length fields, plus the length of all encapsulated Full Server data blocks.                                                                |
| (UDP) Full Server Data Blocks *    | variable  | List of Full Server data blocks conveying data about the UDP sub-servers on the host. See <a href="#">Full Host Server Data Block 4.10.0+</a> , <a href="#">page 4-122</a> for a description of this data block.                        |
| List Block Type                    | uint32    | Initiates a List data block comprising Protocol data blocks conveying network protocol data. This value is always 11.                                                                                                                   |
| List Block Length                  | uint32    | Number of bytes in the list. This number includes the eight bytes of the list block type and length fields, plus the length of all encapsulated Protocol data blocks.                                                                   |
| (Network) Protocol Data Blocks *   | variable  | List of Protocol data blocks conveying data about the network protocols on the host. See <a href="#">Protocol Data Block, page 4-68</a> for a description of this data block.                                                           |
| List Block Type                    | uint32    | Initiates a List data block comprising Protocol data blocks conveying transport protocol data. This value is always 11.                                                                                                                 |
| List Block Length                  | uint32    | Number of bytes in the list. This number includes the eight bytes of the list block type and length fields, plus the length of all encapsulated Protocol data blocks.                                                                   |
| (Transport) Protocol Data Blocks * | variable  | List of Protocol data blocks conveying data about the transport protocols on the host. See <a href="#">Protocol Data Block, page 4-68</a> for a description of this data block.                                                         |
| List Block Type                    | uint32    | Initiates a List data block containing Host MAC Address data blocks. This value is always 11.                                                                                                                                           |
| List Block Length                  | uint32    | Number of bytes in the list, including the list header and all encapsulated Host MAC Address data blocks.                                                                                                                               |
| Host MAC Address Data Blocks *     | variable  | List of Host MAC Address data blocks. See <a href="#">Host MAC Address 4.9+</a> , <a href="#">page 4-108</a> for a description of this data block.                                                                                      |
| Last Seen                          | uint32    | UNIX timestamp that represents the last time the system detected host activity.                                                                                                                                                         |
| Host Type                          | uint32    | Indicates host type. Values include: <ul style="list-style-type: none"> <li>• 0 - host</li> <li>• 1 - router</li> <li>• 2 - bridge</li> <li>• 3 - NAT (network address translation device)</li> <li>• 4 - LB (load balancer)</li> </ul> |
| Business Criticality               | uint16    | Indicates criticality of host to business.                                                                                                                                                                                              |

Table B-32 Full Host Profile Record 5.1.1 Fields (continued)

| Field                                              | Data Type | Description                                                                                                                                                                                                                                                                              |
|----------------------------------------------------|-----------|------------------------------------------------------------------------------------------------------------------------------------------------------------------------------------------------------------------------------------------------------------------------------------------|
| VLAN ID                                            | uint16    | VLAN identification number that indicates which VLAN the host is a member of.                                                                                                                                                                                                            |
| VLAN Type                                          | uint8     | Type of packet encapsulated in the VLAN tag.                                                                                                                                                                                                                                             |
| VLAN Priority                                      | uint8     | Priority value included in the VLAN tag.                                                                                                                                                                                                                                                 |
| Generic List Block Type                            | uint32    | Initiates a Generic List data block comprising Host Vulnerability data blocks conveying Client Application data. This value is always 31.                                                                                                                                                |
| Generic List Block Length                          | uint32    | Number of bytes in the Generic List data block, including the list header and all encapsulated Client Application data blocks.                                                                                                                                                           |
| Full Host Client Application Data Blocks *         | variable  | List of Client Application data blocks. See <a href="#">Full Host Client Application Data Block 5.0+</a> , page 4-136 for a description of this data block.                                                                                                                              |
| String Block Type                                  | uint32    | Initiates a String data block for the host NetBIOS name. This value is always 0.                                                                                                                                                                                                         |
| String Block Length                                | uint32    | Number of bytes in the String data block, including eight bytes for the string block type and length fields, plus the number of bytes in the NetBIOS name string.                                                                                                                        |
| NetBIOS Name                                       | string    | Host NetBIOS name string.                                                                                                                                                                                                                                                                |
| String Block Type                                  | uint32    | Initiates a String data block for host notes. This value is always 0.                                                                                                                                                                                                                    |
| String Block Length                                | uint32    | Number of bytes in the notes String data block, including eight bytes for the string block type and length fields, plus the number of bytes in the notes string.                                                                                                                         |
| Notes                                              | string    | Contains the contents of the Notes host attribute for the host.                                                                                                                                                                                                                          |
| Generic List Block Type                            | uint32    | Initiates a Generic List data block comprising Host Vulnerability data blocks conveying VDB vulnerability data. This value is always 31.                                                                                                                                                 |
| Generic List Block Length                          | uint32    | Number of bytes in the Generic List data block, including the list header and all encapsulated data blocks.                                                                                                                                                                              |
| (VDB) Host Vulnerability Data Blocks *             | variable  | List of Host Vulnerability data blocks for vulnerabilities identified in the Cisco vulnerability database (VDB). See <a href="#">Host Vulnerability Data Block 4.9.0+</a> , page 4-105 for a description of this data block.                                                             |
| Generic List Block Type                            | uint32    | Initiates a Generic List data block comprising Host Vulnerability data blocks conveying third-party scan vulnerability data. This value is always 31.                                                                                                                                    |
| Generic List Block Length                          | uint32    | Number of bytes in the Generic List data block, including the list header and all encapsulated data blocks.                                                                                                                                                                              |
| (Third Party/VDB) Host Vulnerability Data Blocks * | variable  | Host Vulnerability data blocks sourced from a third party scanner and containing information about host vulnerabilities cataloged in the Cisco vulnerability database (VDB). See <a href="#">Host Vulnerability Data Block 4.9.0+</a> , page 4-105 for a description of this data block. |
| Generic List Block Type                            | uint32    | Initiates a Generic List data block comprising Host Vulnerability data blocks conveying third party scan vulnerability data. This value is always 31.                                                                                                                                    |

Table B-32 Full Host Profile Record 5.1.1 Fields (continued)

| Field                                               | Data Type | Description                                                                                                                                                                                                                                                                                        |
|-----------------------------------------------------|-----------|----------------------------------------------------------------------------------------------------------------------------------------------------------------------------------------------------------------------------------------------------------------------------------------------------|
| Generic List Block Length                           | uint32    | Number of bytes in the Generic List data block, including the list header and all encapsulated data blocks.                                                                                                                                                                                        |
| (Third Party Scan) Host Vulnerability Data Blocks * | variable  | Host Vulnerability data blocks sourced from a third party scanner. Note that the host vulnerability IDs for these data blocks are the third party scanner IDs, not Cisco-detected IDs. See <a href="#">Host Vulnerability Data Block 4.9.0+</a> , page 4-105 for a description of this data block. |
| List Block Type                                     | uint32    | Initiates a List data block comprising Attribute Value data blocks conveying attribute data. This value is always 11.                                                                                                                                                                              |
| List Block Length                                   | uint32    | Number of bytes in the List data block, including the list header and all encapsulated data blocks.                                                                                                                                                                                                |
| Attribute Value Data Blocks *                       | variable  | List of Attribute Value data blocks. See <a href="#">Attribute Value Data Block</a> , page 4-75 for a description of the data blocks in this list.                                                                                                                                                 |
| Mobile                                              | uint8     | A true-false flag indicating whether the operating system is running on a mobile device.                                                                                                                                                                                                           |
| Jailbroken                                          | uint8     | A true-false flag indicating whether the mobile device operating system is jailbroken.                                                                                                                                                                                                             |
| VLAN Presence                                       | uint8     | Indicates whether a VLAN is present: <ul style="list-style-type: none"> <li>• 0 - Yes</li> <li>• 1 - No</li> </ul>                                                                                                                                                                                 |

## Full Host Profile Data Block 5.2.x

The Full Host Profile data block for version 5.2.x contains a full set of data describing one host. It has the format shown in the graphic below and explained in the following table. Note that, except for List data blocks, the graphic does not show the fields of the encapsulated data blocks. These encapsulated data blocks are described separately in [Understanding Discovery & Connection Data Structures](#), page 4-1. The Full Host Profile data block a block type value of 140. It supersedes the prior version, which has a block type of 135.



**Note**

An asterisk (\*) next to a block name in the following diagram indicates that multiple instances of the data block may occur.

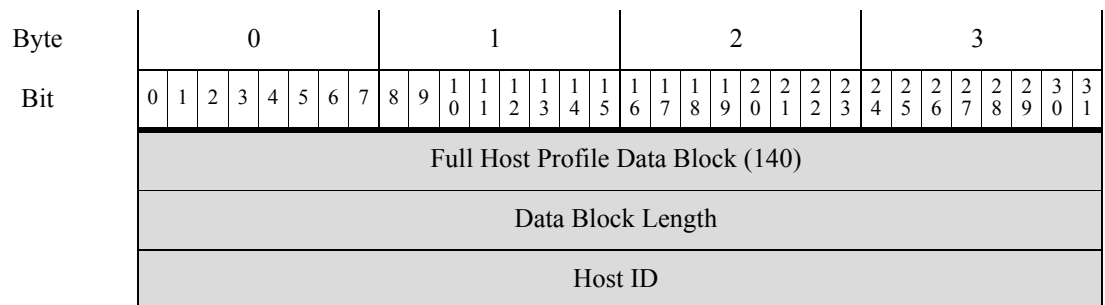

| Byte                    | 0                                              |   |   |   |   |   |   |   | 1                                              |   |    |    |    |    |    |    | 2  |    |    |    |    |    |    |    | 3  |    |    |    |    |    |    |    |
|-------------------------|------------------------------------------------|---|---|---|---|---|---|---|------------------------------------------------|---|----|----|----|----|----|----|----|----|----|----|----|----|----|----|----|----|----|----|----|----|----|----|
| Bit                     | 0                                              | 1 | 2 | 3 | 4 | 5 | 6 | 7 | 8                                              | 9 | 10 | 11 | 12 | 13 | 14 | 15 | 16 | 17 | 18 | 19 | 20 | 21 | 22 | 23 | 24 | 25 | 26 | 27 | 28 | 29 | 30 | 31 |
|                         | Host ID, continued                             |   |   |   |   |   |   |   |                                                |   |    |    |    |    |    |    |    |    |    |    |    |    |    |    |    |    |    |    |    |    |    |    |
|                         | Host ID, continued                             |   |   |   |   |   |   |   |                                                |   |    |    |    |    |    |    |    |    |    |    |    |    |    |    |    |    |    |    |    |    |    |    |
|                         | Host ID, continued                             |   |   |   |   |   |   |   |                                                |   |    |    |    |    |    |    |    |    |    |    |    |    |    |    |    |    |    |    |    |    |    |    |
| IP Addresses            | List Block Type (11)                           |   |   |   |   |   |   |   |                                                |   |    |    |    |    |    |    |    |    |    |    |    |    |    |    |    |    |    |    |    |    |    |    |
|                         | List Block Length                              |   |   |   |   |   |   |   |                                                |   |    |    |    |    |    |    |    |    |    |    |    |    |    |    |    |    |    |    |    |    |    |    |
|                         | IP Address Data Blocks (143)*                  |   |   |   |   |   |   |   |                                                |   |    |    |    |    |    |    |    |    |    |    |    |    |    |    |    |    |    |    |    |    |    |    |
|                         | Hops                                           |   |   |   |   |   |   |   | Generic List Block Type (31)                   |   |    |    |    |    |    |    |    |    |    |    |    |    |    |    |    |    |    |    |    |    |    |    |
|                         | Generic List Block Type, continued             |   |   |   |   |   |   |   | Generic List Block Length                      |   |    |    |    |    |    |    |    |    |    |    |    |    |    |    |    |    |    |    |    |    |    |    |
| OS Derived Fingerprints | Generic List Block Length, continued           |   |   |   |   |   |   |   | Operating System Fingerprint Block Type (130)* |   |    |    |    |    |    |    |    |    |    |    |    |    |    |    |    |    |    |    |    |    |    |    |
|                         | OS Fingerprint Block Type (130)*, con't        |   |   |   |   |   |   |   | Operating System Fingerprint Block Length      |   |    |    |    |    |    |    |    |    |    |    |    |    |    |    |    |    |    |    |    |    |    |    |
|                         | OS Fingerprint Block Length, con't             |   |   |   |   |   |   |   | Operating System Derived Fingerprint Data...   |   |    |    |    |    |    |    |    |    |    |    |    |    |    |    |    |    |    |    |    |    |    |    |
|                         | Generic List Block Type (31)                   |   |   |   |   |   |   |   |                                                |   |    |    |    |    |    |    |    |    |    |    |    |    |    |    |    |    |    |    |    |    |    |    |
|                         | Generic List Block Length                      |   |   |   |   |   |   |   |                                                |   |    |    |    |    |    |    |    |    |    |    |    |    |    |    |    |    |    |    |    |    |    |    |
| Server Fingerprints     | Operating System Fingerprint Block Type (130)* |   |   |   |   |   |   |   |                                                |   |    |    |    |    |    |    |    |    |    |    |    |    |    |    |    |    |    |    |    |    |    |    |
|                         | Operating System Fingerprint Block Length      |   |   |   |   |   |   |   |                                                |   |    |    |    |    |    |    |    |    |    |    |    |    |    |    |    |    |    |    |    |    |    |    |
|                         | Operating System Server Fingerprint Data...    |   |   |   |   |   |   |   |                                                |   |    |    |    |    |    |    |    |    |    |    |    |    |    |    |    |    |    |    |    |    |    |    |
|                         | Generic List Block Type (31)                   |   |   |   |   |   |   |   |                                                |   |    |    |    |    |    |    |    |    |    |    |    |    |    |    |    |    |    |    |    |    |    |    |
|                         | Generic List Block Length                      |   |   |   |   |   |   |   |                                                |   |    |    |    |    |    |    |    |    |    |    |    |    |    |    |    |    |    |    |    |    |    |    |
| Client Fingerprints     | Operating System Fingerprint Block Type (130)* |   |   |   |   |   |   |   |                                                |   |    |    |    |    |    |    |    |    |    |    |    |    |    |    |    |    |    |    |    |    |    |    |
|                         | Operating System Fingerprint Block Length      |   |   |   |   |   |   |   |                                                |   |    |    |    |    |    |    |    |    |    |    |    |    |    |    |    |    |    |    |    |    |    |    |
|                         | Operating System Client Fingerprint Data...    |   |   |   |   |   |   |   |                                                |   |    |    |    |    |    |    |    |    |    |    |    |    |    |    |    |    |    |    |    |    |    |    |
|                         | Generic List Block Type (31)                   |   |   |   |   |   |   |   |                                                |   |    |    |    |    |    |    |    |    |    |    |    |    |    |    |    |    |    |    |    |    |    |    |
|                         | Generic List Block Length                      |   |   |   |   |   |   |   |                                                |   |    |    |    |    |    |    |    |    |    |    |    |    |    |    |    |    |    |    |    |    |    |    |

| Byte                      | 0                                                |   |   |   |   |   |   |   | 1 |   |    |    |    |    |    |    | 2  |    |    |    |    |    |    |    | 3  |    |    |    |    |    |    |    |
|---------------------------|--------------------------------------------------|---|---|---|---|---|---|---|---|---|----|----|----|----|----|----|----|----|----|----|----|----|----|----|----|----|----|----|----|----|----|----|
|                           | 0                                                | 1 | 2 | 3 | 4 | 5 | 6 | 7 | 8 | 9 | 10 | 11 | 12 | 13 | 14 | 15 | 16 | 17 | 18 | 19 | 20 | 21 | 22 | 23 | 24 | 25 | 26 | 27 | 28 | 29 | 30 | 31 |
| VDB Native Fingerprints 1 | Operating System Fingerprint Block Type (130)*   |   |   |   |   |   |   |   |   |   |    |    |    |    |    |    |    |    |    |    |    |    |    |    |    |    |    |    |    |    |    |    |
|                           | Operating System Fingerprint Block Length        |   |   |   |   |   |   |   |   |   |    |    |    |    |    |    |    |    |    |    |    |    |    |    |    |    |    |    |    |    |    |    |
|                           | Operating System VDB Fingerprint Data...         |   |   |   |   |   |   |   |   |   |    |    |    |    |    |    |    |    |    |    |    |    |    |    |    |    |    |    |    |    |    |    |
|                           | Generic List Block Type (31)                     |   |   |   |   |   |   |   |   |   |    |    |    |    |    |    |    |    |    |    |    |    |    |    |    |    |    |    |    |    |    |    |
|                           | Generic List Block Length                        |   |   |   |   |   |   |   |   |   |    |    |    |    |    |    |    |    |    |    |    |    |    |    |    |    |    |    |    |    |    |    |
| VDB Native Fingerprints 2 | Operating System Fingerprint Block Type (130)*   |   |   |   |   |   |   |   |   |   |    |    |    |    |    |    |    |    |    |    |    |    |    |    |    |    |    |    |    |    |    |    |
|                           | Operating System Fingerprint Block Length        |   |   |   |   |   |   |   |   |   |    |    |    |    |    |    |    |    |    |    |    |    |    |    |    |    |    |    |    |    |    |    |
|                           | Operating System VDB Fingerprint Data...         |   |   |   |   |   |   |   |   |   |    |    |    |    |    |    |    |    |    |    |    |    |    |    |    |    |    |    |    |    |    |    |
|                           | Generic List Block Type (31)                     |   |   |   |   |   |   |   |   |   |    |    |    |    |    |    |    |    |    |    |    |    |    |    |    |    |    |    |    |    |    |    |
|                           | Generic List Block Length                        |   |   |   |   |   |   |   |   |   |    |    |    |    |    |    |    |    |    |    |    |    |    |    |    |    |    |    |    |    |    |    |
| User Fingerprints         | Operating System Fingerprint Block Type (130)*   |   |   |   |   |   |   |   |   |   |    |    |    |    |    |    |    |    |    |    |    |    |    |    |    |    |    |    |    |    |    |    |
|                           | Operating System Fingerprint Block Length        |   |   |   |   |   |   |   |   |   |    |    |    |    |    |    |    |    |    |    |    |    |    |    |    |    |    |    |    |    |    |    |
|                           | Operating System User Fingerprint Data...        |   |   |   |   |   |   |   |   |   |    |    |    |    |    |    |    |    |    |    |    |    |    |    |    |    |    |    |    |    |    |    |
|                           | Generic List Block Type (31)                     |   |   |   |   |   |   |   |   |   |    |    |    |    |    |    |    |    |    |    |    |    |    |    |    |    |    |    |    |    |    |    |
|                           | Generic List Block Length                        |   |   |   |   |   |   |   |   |   |    |    |    |    |    |    |    |    |    |    |    |    |    |    |    |    |    |    |    |    |    |    |
| Scan Fingerprints         | Operating System Fingerprint Block Type (130)*   |   |   |   |   |   |   |   |   |   |    |    |    |    |    |    |    |    |    |    |    |    |    |    |    |    |    |    |    |    |    |    |
|                           | Operating System Fingerprint Block Length        |   |   |   |   |   |   |   |   |   |    |    |    |    |    |    |    |    |    |    |    |    |    |    |    |    |    |    |    |    |    |    |
|                           | Operating System Scan Fingerprint Data...        |   |   |   |   |   |   |   |   |   |    |    |    |    |    |    |    |    |    |    |    |    |    |    |    |    |    |    |    |    |    |    |
|                           | Generic List Block Type (31)                     |   |   |   |   |   |   |   |   |   |    |    |    |    |    |    |    |    |    |    |    |    |    |    |    |    |    |    |    |    |    |    |
|                           | Generic List Block Length                        |   |   |   |   |   |   |   |   |   |    |    |    |    |    |    |    |    |    |    |    |    |    |    |    |    |    |    |    |    |    |    |
| Application Fingerprints  | Operating System Fingerprint Block Type (130)*   |   |   |   |   |   |   |   |   |   |    |    |    |    |    |    |    |    |    |    |    |    |    |    |    |    |    |    |    |    |    |    |
|                           | Operating System Fingerprint Block Length        |   |   |   |   |   |   |   |   |   |    |    |    |    |    |    |    |    |    |    |    |    |    |    |    |    |    |    |    |    |    |    |
|                           | Operating System Application Fingerprint Data... |   |   |   |   |   |   |   |   |   |    |    |    |    |    |    |    |    |    |    |    |    |    |    |    |    |    |    |    |    |    |    |
|                           | Generic List Block Type (31)                     |   |   |   |   |   |   |   |   |   |    |    |    |    |    |    |    |    |    |    |    |    |    |    |    |    |    |    |    |    |    |    |
|                           | Generic List Block Length                        |   |   |   |   |   |   |   |   |   |    |    |    |    |    |    |    |    |    |    |    |    |    |    |    |    |    |    |    |    |    |    |



| Byte                     | 0                                                |   |   |   |   |   |   |   | 1 |   |    |    |    |    |    |    | 2  |    |    |    |    |    |    |    | 3  |    |    |    |    |    |    |    |
|--------------------------|--------------------------------------------------|---|---|---|---|---|---|---|---|---|----|----|----|----|----|----|----|----|----|----|----|----|----|----|----|----|----|----|----|----|----|----|
|                          | 0                                                | 1 | 2 | 3 | 4 | 5 | 6 | 7 | 8 | 9 | 10 | 11 | 12 | 13 | 14 | 15 | 16 | 17 | 18 | 19 | 20 | 21 | 22 | 23 | 24 | 25 | 26 | 27 | 28 | 29 | 30 | 31 |
| Conflict Fingerprints    | Operating System Fingerprint Block Type (130)*   |   |   |   |   |   |   |   |   |   |    |    |    |    |    |    |    |    |    |    |    |    |    |    |    |    |    |    |    |    |    |    |
|                          | Operating System Fingerprint Block Length        |   |   |   |   |   |   |   |   |   |    |    |    |    |    |    |    |    |    |    |    |    |    |    |    |    |    |    |    |    |    |    |
|                          | Operating System Conflict Fingerprint Data...    |   |   |   |   |   |   |   |   |   |    |    |    |    |    |    |    |    |    |    |    |    |    |    |    |    |    |    |    |    |    |    |
|                          | Generic List Block Type (31)                     |   |   |   |   |   |   |   |   |   |    |    |    |    |    |    |    |    |    |    |    |    |    |    |    |    |    |    |    |    |    |    |
|                          | Generic List Block Length                        |   |   |   |   |   |   |   |   |   |    |    |    |    |    |    |    |    |    |    |    |    |    |    |    |    |    |    |    |    |    |    |
| Mobile Fingerprints      | Operating System Fingerprint Block Type (130)*   |   |   |   |   |   |   |   |   |   |    |    |    |    |    |    |    |    |    |    |    |    |    |    |    |    |    |    |    |    |    |    |
|                          | Operating System Fingerprint Block Length        |   |   |   |   |   |   |   |   |   |    |    |    |    |    |    |    |    |    |    |    |    |    |    |    |    |    |    |    |    |    |    |
|                          | Operating System Mobile Fingerprint Data...      |   |   |   |   |   |   |   |   |   |    |    |    |    |    |    |    |    |    |    |    |    |    |    |    |    |    |    |    |    |    |    |
|                          | Generic List Block Type (31)                     |   |   |   |   |   |   |   |   |   |    |    |    |    |    |    |    |    |    |    |    |    |    |    |    |    |    |    |    |    |    |    |
|                          | Generic List Block Length                        |   |   |   |   |   |   |   |   |   |    |    |    |    |    |    |    |    |    |    |    |    |    |    |    |    |    |    |    |    |    |    |
| IPv6 Server Fingerprints | Operating System Fingerprint Block Type (130)*   |   |   |   |   |   |   |   |   |   |    |    |    |    |    |    |    |    |    |    |    |    |    |    |    |    |    |    |    |    |    |    |
|                          | Operating System Fingerprint Block Length        |   |   |   |   |   |   |   |   |   |    |    |    |    |    |    |    |    |    |    |    |    |    |    |    |    |    |    |    |    |    |    |
|                          | Operating System IPv6 Server Fingerprint Data... |   |   |   |   |   |   |   |   |   |    |    |    |    |    |    |    |    |    |    |    |    |    |    |    |    |    |    |    |    |    |    |
|                          | Generic List Block Type (31)                     |   |   |   |   |   |   |   |   |   |    |    |    |    |    |    |    |    |    |    |    |    |    |    |    |    |    |    |    |    |    |    |
|                          | Generic List Block Length                        |   |   |   |   |   |   |   |   |   |    |    |    |    |    |    |    |    |    |    |    |    |    |    |    |    |    |    |    |    |    |    |
| Ipv6 Client Fingerprints | Operating System Fingerprint Block Type (130)*   |   |   |   |   |   |   |   |   |   |    |    |    |    |    |    |    |    |    |    |    |    |    |    |    |    |    |    |    |    |    |    |
|                          | Operating System Fingerprint Block Length        |   |   |   |   |   |   |   |   |   |    |    |    |    |    |    |    |    |    |    |    |    |    |    |    |    |    |    |    |    |    |    |
|                          | Operating System Ipv6 Client Fingerprint Data... |   |   |   |   |   |   |   |   |   |    |    |    |    |    |    |    |    |    |    |    |    |    |    |    |    |    |    |    |    |    |    |
|                          | Generic List Block Type (31)                     |   |   |   |   |   |   |   |   |   |    |    |    |    |    |    |    |    |    |    |    |    |    |    |    |    |    |    |    |    |    |    |
|                          | Generic List Block Length                        |   |   |   |   |   |   |   |   |   |    |    |    |    |    |    |    |    |    |    |    |    |    |    |    |    |    |    |    |    |    |    |
| Ipv6 DHCP Fingerprints   | Operating System Fingerprint Block Type (130)*   |   |   |   |   |   |   |   |   |   |    |    |    |    |    |    |    |    |    |    |    |    |    |    |    |    |    |    |    |    |    |    |
|                          | Operating System Fingerprint Block Length        |   |   |   |   |   |   |   |   |   |    |    |    |    |    |    |    |    |    |    |    |    |    |    |    |    |    |    |    |    |    |    |
|                          | Operating System IPv6 DHCP Fingerprint Data...   |   |   |   |   |   |   |   |   |   |    |    |    |    |    |    |    |    |    |    |    |    |    |    |    |    |    |    |    |    |    |    |
|                          | Generic List Block Type (31)                     |   |   |   |   |   |   |   |   |   |    |    |    |    |    |    |    |    |    |    |    |    |    |    |    |    |    |    |    |    |    |    |
|                          | Generic List Block Length                        |   |   |   |   |   |   |   |   |   |    |    |    |    |    |    |    |    |    |    |    |    |    |    |    |    |    |    |    |    |    |    |

| Byte                    | 0                                               |   |   |   |   |   |   |   | 1             |   |    |    |    |    |    |    | 2                                               |    |    |    |    |    |    |    | 3  |    |    |    |    |    |    |    |
|-------------------------|-------------------------------------------------|---|---|---|---|---|---|---|---------------|---|----|----|----|----|----|----|-------------------------------------------------|----|----|----|----|----|----|----|----|----|----|----|----|----|----|----|
|                         | 0                                               | 1 | 2 | 3 | 4 | 5 | 6 | 7 | 8             | 9 | 10 | 11 | 12 | 13 | 14 | 15 | 16                                              | 17 | 18 | 19 | 20 | 21 | 22 | 23 | 24 | 25 | 26 | 27 | 28 | 29 | 30 | 31 |
| User Agent Fingerprints | Operating System Fingerprint Block Type (130)*  |   |   |   |   |   |   |   |               |   |    |    |    |    |    |    |                                                 |    |    |    |    |    |    |    |    |    |    |    |    |    |    |    |
|                         | Operating System Fingerprint Block Length       |   |   |   |   |   |   |   |               |   |    |    |    |    |    |    |                                                 |    |    |    |    |    |    |    |    |    |    |    |    |    |    |    |
|                         | Operating System User Agent Fingerprint Data... |   |   |   |   |   |   |   |               |   |    |    |    |    |    |    |                                                 |    |    |    |    |    |    |    |    |    |    |    |    |    |    |    |
| (TCP) Full Server Data  | List Block Type (11)...                         |   |   |   |   |   |   |   |               |   |    |    |    |    |    |    |                                                 |    |    |    |    |    |    |    |    |    |    |    |    |    |    |    |
|                         | List Block Length...                            |   |   |   |   |   |   |   |               |   |    |    |    |    |    |    |                                                 |    |    |    |    |    |    |    |    |    |    |    |    |    |    |    |
|                         | (TCP) Full Server Data Blocks (104)*            |   |   |   |   |   |   |   |               |   |    |    |    |    |    |    |                                                 |    |    |    |    |    |    |    |    |    |    |    |    |    |    |    |
| (UDP) Full Server Data  | List Block Type (11)                            |   |   |   |   |   |   |   |               |   |    |    |    |    |    |    |                                                 |    |    |    |    |    |    |    |    |    |    |    |    |    |    |    |
|                         | List Block Length                               |   |   |   |   |   |   |   |               |   |    |    |    |    |    |    |                                                 |    |    |    |    |    |    |    |    |    |    |    |    |    |    |    |
|                         | (UDP) Full Server Data Blocks (104)*            |   |   |   |   |   |   |   |               |   |    |    |    |    |    |    |                                                 |    |    |    |    |    |    |    |    |    |    |    |    |    |    |    |
| Network Protocol Data   | List Block Type (11)                            |   |   |   |   |   |   |   |               |   |    |    |    |    |    |    |                                                 |    |    |    |    |    |    |    |    |    |    |    |    |    |    |    |
|                         | List Block Length                               |   |   |   |   |   |   |   |               |   |    |    |    |    |    |    |                                                 |    |    |    |    |    |    |    |    |    |    |    |    |    |    |    |
|                         | (Network) Protocol Data Blocks (4)*             |   |   |   |   |   |   |   |               |   |    |    |    |    |    |    |                                                 |    |    |    |    |    |    |    |    |    |    |    |    |    |    |    |
| Transport Protocol Data | List Block Type (11)                            |   |   |   |   |   |   |   |               |   |    |    |    |    |    |    |                                                 |    |    |    |    |    |    |    |    |    |    |    |    |    |    |    |
|                         | List Block Length                               |   |   |   |   |   |   |   |               |   |    |    |    |    |    |    |                                                 |    |    |    |    |    |    |    |    |    |    |    |    |    |    |    |
|                         | (Transport) Protocol Data Blocks (4)*           |   |   |   |   |   |   |   |               |   |    |    |    |    |    |    |                                                 |    |    |    |    |    |    |    |    |    |    |    |    |    |    |    |
| MAC Address Data        | List Block Type (11)                            |   |   |   |   |   |   |   |               |   |    |    |    |    |    |    |                                                 |    |    |    |    |    |    |    |    |    |    |    |    |    |    |    |
|                         | List Block Length                               |   |   |   |   |   |   |   |               |   |    |    |    |    |    |    |                                                 |    |    |    |    |    |    |    |    |    |    |    |    |    |    |    |
|                         | Host MAC Address Data Blocks (95)*              |   |   |   |   |   |   |   |               |   |    |    |    |    |    |    |                                                 |    |    |    |    |    |    |    |    |    |    |    |    |    |    |    |
|                         | Last Seen                                       |   |   |   |   |   |   |   |               |   |    |    |    |    |    |    |                                                 |    |    |    |    |    |    |    |    |    |    |    |    |    |    |    |
|                         | Host Type                                       |   |   |   |   |   |   |   |               |   |    |    |    |    |    |    |                                                 |    |    |    |    |    |    |    |    |    |    |    |    |    |    |    |
|                         | Business Criticality                            |   |   |   |   |   |   |   |               |   |    |    |    |    |    |    | VLAN ID                                         |    |    |    |    |    |    |    |    |    |    |    |    |    |    |    |
|                         | VLAN Type                                       |   |   |   |   |   |   |   | VLAN Priority |   |    |    |    |    |    |    | Generic List Block Type (31)                    |    |    |    |    |    |    |    |    |    |    |    |    |    |    |    |
|                         | Generic List Block Type, continued              |   |   |   |   |   |   |   |               |   |    |    |    |    |    |    | Generic List Block Length                       |    |    |    |    |    |    |    |    |    |    |    |    |    |    |    |
| Host Client Data        | Generic List Block Length, continued            |   |   |   |   |   |   |   |               |   |    |    |    |    |    |    | Full Host Client Application Data Blocks (112)* |    |    |    |    |    |    |    |    |    |    |    |    |    |    |    |

| Byte                    | 0                                                                              |   |   |   |   |   |   |   | 1 |   |    |    |    |    |    |            | 2  |    |    |    |    |    |    |    | 3  |    |    |    |    |    |    |    |
|-------------------------|--------------------------------------------------------------------------------|---|---|---|---|---|---|---|---|---|----|----|----|----|----|------------|----|----|----|----|----|----|----|----|----|----|----|----|----|----|----|----|
|                         | 0                                                                              | 1 | 2 | 3 | 4 | 5 | 6 | 7 | 8 | 9 | 10 | 11 | 12 | 13 | 14 | 15         | 16 | 17 | 18 | 19 | 20 | 21 | 22 | 23 | 24 | 25 | 26 | 27 | 28 | 29 | 30 | 31 |
| NetBios Name            | String Block Type (0)                                                          |   |   |   |   |   |   |   |   |   |    |    |    |    |    |            |    |    |    |    |    |    |    |    |    |    |    |    |    |    |    |    |
| Name                    | String Block Length                                                            |   |   |   |   |   |   |   |   |   |    |    |    |    |    |            |    |    |    |    |    |    |    |    |    |    |    |    |    |    |    |    |
|                         | NetBIOS Name String...                                                         |   |   |   |   |   |   |   |   |   |    |    |    |    |    |            |    |    |    |    |    |    |    |    |    |    |    |    |    |    |    |    |
| Notes Data              | String Block Type (0)                                                          |   |   |   |   |   |   |   |   |   |    |    |    |    |    |            |    |    |    |    |    |    |    |    |    |    |    |    |    |    |    |    |
|                         | String Block Length                                                            |   |   |   |   |   |   |   |   |   |    |    |    |    |    |            |    |    |    |    |    |    |    |    |    |    |    |    |    |    |    |    |
|                         | Notes String....                                                               |   |   |   |   |   |   |   |   |   |    |    |    |    |    |            |    |    |    |    |    |    |    |    |    |    |    |    |    |    |    |    |
| (VDB) Host Vulns        | Generic List Block Type (31)                                                   |   |   |   |   |   |   |   |   |   |    |    |    |    |    |            |    |    |    |    |    |    |    |    |    |    |    |    |    |    |    |    |
|                         | Generic List Block Length                                                      |   |   |   |   |   |   |   |   |   |    |    |    |    |    |            |    |    |    |    |    |    |    |    |    |    |    |    |    |    |    |    |
|                         | (VDB) Host Vulnerability Data Blocks (85)*                                     |   |   |   |   |   |   |   |   |   |    |    |    |    |    |            |    |    |    |    |    |    |    |    |    |    |    |    |    |    |    |    |
| 3rd Pty/VDB) Host Vulns | Generic List Block Type (31)                                                   |   |   |   |   |   |   |   |   |   |    |    |    |    |    |            |    |    |    |    |    |    |    |    |    |    |    |    |    |    |    |    |
|                         | Generic List Block Length                                                      |   |   |   |   |   |   |   |   |   |    |    |    |    |    |            |    |    |    |    |    |    |    |    |    |    |    |    |    |    |    |    |
|                         | (Third Party/VDB) Host Vulnerability Data Blocks (85)*                         |   |   |   |   |   |   |   |   |   |    |    |    |    |    |            |    |    |    |    |    |    |    |    |    |    |    |    |    |    |    |    |
| 3rd Pty Scan Host Vulns | Generic List Block Type (31)                                                   |   |   |   |   |   |   |   |   |   |    |    |    |    |    |            |    |    |    |    |    |    |    |    |    |    |    |    |    |    |    |    |
|                         | Generic List Block Length                                                      |   |   |   |   |   |   |   |   |   |    |    |    |    |    |            |    |    |    |    |    |    |    |    |    |    |    |    |    |    |    |    |
|                         | (Third Party Scan) Host Vulnerability Data Blocks with Original Vuln IDs (85)* |   |   |   |   |   |   |   |   |   |    |    |    |    |    |            |    |    |    |    |    |    |    |    |    |    |    |    |    |    |    |    |
| Attribute Value Data    | List Block Type (11)                                                           |   |   |   |   |   |   |   |   |   |    |    |    |    |    |            |    |    |    |    |    |    |    |    |    |    |    |    |    |    |    |    |
|                         | List Block Length                                                              |   |   |   |   |   |   |   |   |   |    |    |    |    |    |            |    |    |    |    |    |    |    |    |    |    |    |    |    |    |    |    |
|                         | Attribute Value Data Blocks *                                                  |   |   |   |   |   |   |   |   |   |    |    |    |    |    |            |    |    |    |    |    |    |    |    |    |    |    |    |    |    |    |    |
| Mobile                  |                                                                                |   |   |   |   |   |   |   |   |   |    |    |    |    |    | Jailbroken |    |    |    |    |    |    |    |    |    |    |    |    |    |    |    |    |

The following table describes the components of the Full Host Profile for 5.2.x record.

**Table B-33 Full Host Profile Record 5.2.x Fields**

| Field             | Data Type | Description                                                                                                                                                             |
|-------------------|-----------|-------------------------------------------------------------------------------------------------------------------------------------------------------------------------|
| Host ID           | uint8[16] | Unique ID number of the host. This is a UUID.                                                                                                                           |
| List Block Type   | uint32    | Initiates a List data block comprising IP address data blocks conveying TCP service data. This value is always 11.                                                      |
| List Block Length | uint32    | Number of bytes in the list. This number includes the eight bytes of the list block type and length fields, plus the length of all encapsulated IP address data blocks. |

Table B-33 Full Host Profile Record 5.2.x Fields (continued)

| Field                                                           | Data Type | Description                                                                                                                                                                                                                                                                  |
|-----------------------------------------------------------------|-----------|------------------------------------------------------------------------------------------------------------------------------------------------------------------------------------------------------------------------------------------------------------------------------|
| IP Address                                                      | variable  | IP addresses of the host and when each IP address was last seen. See <a href="#">Host IP Address Data Block, page 4-90</a> for a description of this data block.                                                                                                             |
| Hops                                                            | uint8     | Number of network hops from the host to the device.                                                                                                                                                                                                                          |
| Generic List Block Type                                         | uint32    | Initiates a Generic List data block comprising Operating System Fingerprint data blocks conveying fingerprint data derived from the existing fingerprints for the host. This value is always 31.                                                                             |
| Generic List Block Length                                       | uint32    | Number of bytes in the Generic List data block, including the list header and all encapsulated Operating System Fingerprint data blocks.                                                                                                                                     |
| Operating System Derived Fingerprint Data Blocks *              | variable  | Operating System Fingerprint data blocks containing information about the operating system on a host derived from the existing fingerprints for the host. See <a href="#">Operating System Fingerprint Data Block 5.1+, page 4-141</a> for a description of this data block. |
| Generic List Block Type                                         | uint32    | Initiates a Generic List data block comprising Operating System Fingerprint data blocks conveying fingerprint data identified using a server fingerprint. This value is always 31.                                                                                           |
| Generic List Block Length                                       | uint32    | Number of bytes in the Generic List data block, including the list header and all encapsulated Operating System Fingerprint data blocks.                                                                                                                                     |
| Operating System Fingerprint (Server Fingerprint) Data Blocks * | variable  | Operating System Fingerprint data blocks containing information about the operating system on a host identified using a server fingerprint. See <a href="#">Operating System Fingerprint Data Block 5.1+, page 4-141</a> for a description of this data block.               |
| Generic List Block Type                                         | uint32    | Initiates a Generic List data block comprising Operating System Fingerprint data blocks conveying fingerprint data identified using a client fingerprint. This value is always 31.                                                                                           |
| Generic List Block Length                                       | uint32    | Number of bytes in the Generic List data block, including the list header and all encapsulated Operating System Fingerprint data blocks.                                                                                                                                     |
| Operating System Fingerprint (Client Fingerprint) Data Blocks * | variable  | Operating System Fingerprint data blocks containing information about the operating system on a host identified using a client fingerprint. See <a href="#">Operating System Fingerprint Data Block 5.1+, page 4-141</a> for a description of this data block.               |
| Generic List Block Type                                         | uint32    | Initiates a Generic List data block comprising Operating System Fingerprint data blocks conveying fingerprint data identified using a Cisco VDB fingerprint. This value is always 31.                                                                                        |
| Generic List Block Length                                       | uint32    | Number of bytes in the Generic List data block, including the list header and all encapsulated Operating System Fingerprint data blocks.                                                                                                                                     |

Table B-33 Full Host Profile Record 5.2.x Fields (continued)

| Field                                                                  | Data Type | Description                                                                                                                                                                                                                                                                                           |
|------------------------------------------------------------------------|-----------|-------------------------------------------------------------------------------------------------------------------------------------------------------------------------------------------------------------------------------------------------------------------------------------------------------|
| Operating System Fingerprint (VDB) Native Fingerprint 1) Data Blocks * | variable  | Operating System Fingerprint data blocks containing information about the operating system on a host identified using the fingerprints in the Cisco vulnerability database (VDB). See <a href="#">Operating System Fingerprint Data Block 5.1+</a> , page 4-141 for a description of this data block. |
| Generic List Block Type                                                | uint32    | Initiates a Generic List data block comprising Operating System Fingerprint data blocks conveying fingerprint data identified using a Cisco VDB fingerprint. This value is always 31.                                                                                                                 |
| Generic List Block Length                                              | uint32    | Number of bytes in the Generic List data block, including the list header and all encapsulated Operating System Fingerprint data blocks.                                                                                                                                                              |
| Operating System Fingerprint (VDB) Native Fingerprint 2) Data Blocks * | variable  | Operating System Fingerprint data blocks containing information about the operating system on a host identified using the fingerprints in the Cisco vulnerability database (VDB). See <a href="#">Operating System Fingerprint Data Block 5.1+</a> , page 4-141 for a description of this data block. |
| Generic List Block Type                                                | uint32    | Initiates a Generic List data block comprising Operating System Fingerprint data blocks conveying fingerprint data added by a user. This value is always 31.                                                                                                                                          |
| Generic List Block Length                                              | uint32    | Number of bytes in the Generic List data block, including the list header and all encapsulated Operating System Fingerprint data blocks.                                                                                                                                                              |
| Operating System Fingerprint (User Fingerprint) Data Blocks *          | variable  | Operating System Fingerprint data blocks containing information about the operating system on a host added by a user. See <a href="#">Operating System Fingerprint Data Block 5.1+</a> , page 4-141 for a description of this data block.                                                             |
| Generic List Block Type                                                | uint32    | Initiates a Generic List data block comprising Operating System Fingerprint data blocks conveying fingerprint data added by a vulnerability scanner. This value is always 31.                                                                                                                         |
| Generic List Block Length                                              | uint32    | Number of bytes in the Generic List data block, including the list header and all encapsulated Operating System Fingerprint data blocks.                                                                                                                                                              |
| Operating System Fingerprint (Scan Fingerprint) Data Blocks *          | variable  | Operating System Fingerprint data blocks containing information about the operating system on a host added by a vulnerability scanner. See <a href="#">Operating System Fingerprint Data Block 5.1+</a> , page 4-141 for a description of this data block.                                            |
| Generic List Block Type                                                | uint32    | Initiates a Generic List data block comprising Operating System Fingerprint data blocks conveying fingerprint data added by an application. This value is always 31.                                                                                                                                  |
| Generic List Block Length                                              | uint32    | Number of bytes in the Generic List data block, including the list header and all encapsulated Operating System Fingerprint data blocks.                                                                                                                                                              |

Table B-33 Full Host Profile Record 5.2.x Fields (continued)

| Field                                                                | Data Type | Description                                                                                                                                                                                                                                                                |
|----------------------------------------------------------------------|-----------|----------------------------------------------------------------------------------------------------------------------------------------------------------------------------------------------------------------------------------------------------------------------------|
| Operating System Fingerprint (Application Fingerprint) Data Blocks * | variable  | Operating System Fingerprint data blocks containing information about the operating system on a host added by an application. See <a href="#">Operating System Fingerprint Data Block 5.1+</a> , page 4-141 for a description of this data block.                          |
| Generic List Block Type                                              | uint32    | Initiates a Generic List data block comprising Operating System Fingerprint data blocks conveying fingerprint data selected through fingerprint conflict resolution. This value is always 31.                                                                              |
| Generic List Block Length                                            | uint32    | Number of bytes in the Generic List data block, including the list header and all encapsulated Operating System Fingerprint data blocks.                                                                                                                                   |
| Operating System Fingerprint (Conflict Fingerprint) Data Blocks *    | variable  | Operating System Fingerprint data blocks containing information about the operating system on a host selected through fingerprint conflict resolution. See <a href="#">Operating System Fingerprint Data Block 5.1+</a> , page 4-141 for a description of this data block. |
| Generic List Block Type                                              | uint32    | Initiates a Generic List data block comprising Operating System Fingerprint data blocks conveying mobile device fingerprint data. This value is always 31.                                                                                                                 |
| Generic List Block Length                                            | uint32    | Number of bytes in the Generic List data block, including the list header and all encapsulated Operating System Fingerprint data blocks.                                                                                                                                   |
| Operating System Fingerprint (Mobile) Data Blocks *                  | variable  | Operating System Fingerprint data blocks containing information about the operating system on a mobile device host. See <a href="#">Operating System Fingerprint Data Block 5.1+</a> , page 4-141 for a description of this data block.                                    |
| Generic List Block Type                                              | uint32    | Initiates a Generic List data block comprising Operating System Fingerprint data blocks conveying fingerprint data identified using an IPv6 server fingerprint. This value is always 31.                                                                                   |
| Generic List Block Length                                            | uint32    | Number of bytes in the Generic List data block, including the list header and all encapsulated Operating System Fingerprint data blocks.                                                                                                                                   |
| Operating System Fingerprint (IPv6 Server Fingerprint) Data Blocks * | variable  | Operating System Fingerprint data blocks containing information about the operating system on a host identified using an IPv6 server fingerprint. See <a href="#">Operating System Fingerprint Data Block 5.1+</a> , page 4-141 for a description of this data block.      |
| Generic List Block Type                                              | uint32    | Initiates a Generic List data block comprising Operating System Fingerprint data blocks conveying fingerprint data identified using an IPv6 client fingerprint. This value is always 31.                                                                                   |
| Generic List Block Length                                            | uint32    | Number of bytes in the Generic List data block, including the list header and all encapsulated Operating System Fingerprint data blocks.                                                                                                                                   |

Table B-33 Full Host Profile Record 5.2.x Fields (continued)

| Field                                                                | Data Type | Description                                                                                                                                                                                                                                                           |
|----------------------------------------------------------------------|-----------|-----------------------------------------------------------------------------------------------------------------------------------------------------------------------------------------------------------------------------------------------------------------------|
| Operating System Fingerprint (IPv6 Client Fingerprint) Data Blocks * | variable  | Operating System Fingerprint data blocks containing information about the operating system on a host identified using an IPv6 client fingerprint. See <a href="#">Operating System Fingerprint Data Block 5.1+</a> , page 4-141 for a description of this data block. |
| Generic List Block Type                                              | uint32    | Initiates a Generic List data block comprising Operating System Fingerprint data blocks conveying fingerprint data identified using an IPv6 DHCP fingerprint. This value is always 31.                                                                                |
| Generic List Block Length                                            | uint32    | Number of bytes in the Generic List data block, including the list header and all encapsulated Operating System Fingerprint data blocks.                                                                                                                              |
| Operating System Fingerprint (IPv6 DHCP) Data Blocks *               | variable  | Operating System Fingerprint data blocks containing information about the operating system on a host identified using an IPv6 DHCP fingerprint. See <a href="#">Operating System Fingerprint Data Block 5.1+</a> , page 4-141 for a description of this data block.   |
| Generic List Block Type                                              | uint32    | Initiates a Generic List data block comprising Operating System Fingerprint data blocks conveying fingerprint data identified using a user agent fingerprint. This value is always 31.                                                                                |
| Generic List Block Length                                            | uint32    | Number of bytes in the Generic List data block, including the list header and all encapsulated Operating System Fingerprint data blocks.                                                                                                                              |
| Operating System Fingerprint (User Agent) Data Blocks *              | variable  | Operating System Fingerprint data blocks containing information about the operating system on a host identified using a user agent fingerprint. See <a href="#">Operating System Fingerprint Data Block 5.1+</a> , page 4-141 for a description of this data block.   |
| List Block Type                                                      | uint32    | Initiates a List data block comprising Full Server data blocks conveying TCP service data. This value is always 11.                                                                                                                                                   |
| List Block Length                                                    | uint32    | Number of bytes in the list. This number includes the eight bytes of the list block type and length fields, plus the length of all encapsulated Full Server data blocks.                                                                                              |
| (TCP) Full Server Data Blocks *                                      | variable  | List of Full Server data blocks conveying data about the TCP services on the host. See <a href="#">Full Host Server Data Block 4.10.0+</a> , page 4-122 for a description of this data block.                                                                         |
| List Block Type                                                      | uint32    | Initiates a List data block comprising Full Server data blocks conveying UDP service data. This value is always 11.                                                                                                                                                   |
| List Block Length                                                    | uint32    | Number of bytes in the list. This number includes the eight bytes of the list block type and length fields, plus the length of all encapsulated Full Server data blocks.                                                                                              |
| (UDP) Full Server Data Blocks *                                      | variable  | List of Full Server data blocks conveying data about the UDP sub-servers on the host. See <a href="#">Full Host Server Data Block 4.10.0+</a> , page 4-122 for a description of this data block.                                                                      |
| List Block Type                                                      | uint32    | Initiates a List data block comprising Protocol data blocks conveying network protocol data. This value is always 11.                                                                                                                                                 |

Table B-33 Full Host Profile Record 5.2.x Fields (continued)

| Field                              | Data Type | Description                                                                                                                                                                                                                             |
|------------------------------------|-----------|-----------------------------------------------------------------------------------------------------------------------------------------------------------------------------------------------------------------------------------------|
| List Block Length                  | uint32    | Number of bytes in the list. This number includes the eight bytes of the list block type and length fields, plus the length of all encapsulated Protocol data blocks.                                                                   |
| (Network) Protocol Data Blocks *   | variable  | List of Protocol data blocks conveying data about the network protocols on the host. See <a href="#">Protocol Data Block, page 4-68</a> for a description of this data block.                                                           |
| List Block Type                    | uint32    | Initiates a List data block comprising Protocol data blocks conveying transport protocol data. This value is always 11.                                                                                                                 |
| List Block Length                  | uint32    | Number of bytes in the list. This number includes the eight bytes of the list block type and length fields, plus the length of all encapsulated Protocol data blocks.                                                                   |
| (Transport) Protocol Data Blocks * | variable  | List of Protocol data blocks conveying data about the transport protocols on the host. See <a href="#">Protocol Data Block, page 4-68</a> for a description of this data block.                                                         |
| List Block Type                    | uint32    | Initiates a List data block containing Host MAC Address data blocks. This value is always 11.                                                                                                                                           |
| List Block Length                  | uint32    | Number of bytes in the list, including the list header and all encapsulated Host MAC Address data blocks.                                                                                                                               |
| Host MAC Address Data Blocks *     | variable  | List of Host MAC Address data blocks. See <a href="#">Host MAC Address 4.9+, page 4-108</a> for a description of this data block.                                                                                                       |
| Last Seen                          | uint32    | UNIX timestamp that represents the last time the system detected host activity.                                                                                                                                                         |
| Host Type                          | uint32    | Indicates host type. Values include: <ul style="list-style-type: none"> <li>• 0 - host</li> <li>• 1 - router</li> <li>• 2 - bridge</li> <li>• 3 - NAT (network address translation device)</li> <li>• 4 - LB (load balancer)</li> </ul> |
| Business Criticality               | uint16    | Indicates criticality of host to business.                                                                                                                                                                                              |
| VLAN ID                            | uint16    | VLAN identification number that indicates which VLAN the host is a member of.                                                                                                                                                           |
| VLAN Type                          | uint8     | Type of packet encapsulated in the VLAN tag.                                                                                                                                                                                            |
| VLAN Priority                      | uint8     | Priority value included in the VLAN tag.                                                                                                                                                                                                |
| Generic List Block Type            | uint32    | Initiates a Generic List data block comprising Host Vulnerability data blocks conveying Client Application data. This value is always 31.                                                                                               |
| Generic List Block Length          | uint32    | Number of bytes in the Generic List data block, including the list header and all encapsulated Client Application data blocks.                                                                                                          |



Table B-33 Full Host Profile Record 5.2.x Fields (continued)

| Field                                               | Data Type | Description                                                                                                                                                                                                                                                                                        |
|-----------------------------------------------------|-----------|----------------------------------------------------------------------------------------------------------------------------------------------------------------------------------------------------------------------------------------------------------------------------------------------------|
| Full Host Client Application Data Blocks *          | variable  | List of Client Application data blocks. See <a href="#">Full Host Client Application Data Block 5.0+</a> , page 4-136 for a description of this data block.                                                                                                                                        |
| String Block Type                                   | uint32    | Initiates a String data block for the host NetBIOS name. This value is always 0.                                                                                                                                                                                                                   |
| String Block Length                                 | uint32    | Number of bytes in the String data block, including eight bytes for the string block type and length fields, plus the number of bytes in the NetBIOS name string.                                                                                                                                  |
| NetBIOS Name                                        | string    | Host NetBIOS name string.                                                                                                                                                                                                                                                                          |
| String Block Type                                   | uint32    | Initiates a String data block for host notes. This value is always 0.                                                                                                                                                                                                                              |
| String Block Length                                 | uint32    | Number of bytes in the notes String data block, including eight bytes for the string block type and length fields, plus the number of bytes in the notes string.                                                                                                                                   |
| Notes                                               | string    | Contains the contents of the Notes host attribute for the host.                                                                                                                                                                                                                                    |
| Generic List Block Type                             | uint32    | Initiates a Generic List data block comprising Host Vulnerability data blocks conveying VDB vulnerability data. This value is always 31.                                                                                                                                                           |
| Generic List Block Length                           | uint32    | Number of bytes in the Generic List data block, including the list header and all encapsulated data blocks.                                                                                                                                                                                        |
| (VDB) Host Vulnerability Data Blocks *              | variable  | List of Host Vulnerability data blocks for vulnerabilities identified in the Cisco vulnerability database (VDB). See <a href="#">Host Vulnerability Data Block 4.9.0+</a> , page 4-105 for a description of this data block.                                                                       |
| Generic List Block Type                             | uint32    | Initiates a Generic List data block comprising Host Vulnerability data blocks conveying third-party scan vulnerability data. This value is always 31.                                                                                                                                              |
| Generic List Block Length                           | uint32    | Number of bytes in the Generic List data block, including the list header and all encapsulated data blocks.                                                                                                                                                                                        |
| (Third Party/VDB) Host Vulnerability Data Blocks *  | variable  | Host Vulnerability data blocks sourced from a third party scanner and containing information about host vulnerabilities cataloged in the Cisco vulnerability database (VDB). See <a href="#">Host Vulnerability Data Block 4.9.0+</a> , page 4-105 for a description of this data block.           |
| Generic List Block Type                             | uint32    | Initiates a Generic List data block comprising Host Vulnerability data blocks conveying third party scan vulnerability data. This value is always 31.                                                                                                                                              |
| Generic List Block Length                           | uint32    | Number of bytes in the Generic List data block, including the list header and all encapsulated data blocks.                                                                                                                                                                                        |
| (Third Party Scan) Host Vulnerability Data Blocks * | variable  | Host Vulnerability data blocks sourced from a third party scanner. Note that the host vulnerability IDs for these data blocks are the third party scanner IDs, not Cisco-detected IDs. See <a href="#">Host Vulnerability Data Block 4.9.0+</a> , page 4-105 for a description of this data block. |
| List Block Type                                     | uint32    | Initiates a List data block comprising Attribute Value data blocks conveying attribute data. This value is always 11.                                                                                                                                                                              |

Table B-33 Full Host Profile Record 5.2.x Fields (continued)

| Field                         | Data Type | Description                                                                                                                                       |
|-------------------------------|-----------|---------------------------------------------------------------------------------------------------------------------------------------------------|
| List Block Length             | uint32    | Number of bytes in the List data block, including the list header and all encapsulated data blocks.                                               |
| Attribute Value Data Blocks * | variable  | List of Attribute Value data blocks. See <a href="#">Attribute Value Data Block, page 4-75</a> for a description of the data blocks in this list. |
| Mobile                        | uint8     | A true-false flag indicating whether the operating system is running on a mobile device.                                                          |
| Jailbroken                    | uint8     | A true-false flag indicating whether the mobile device operating system is jailbroken.                                                            |

## Host Profile Data Block for 5.1.x

The following diagram shows the format of a Host Profile data block. The data block also does not include a host criticality value, but does include a VLAN presence indicator. In addition, a data block can convey a NetBIOS name for the host. The Host Profile data block has a block type of 132.



**Note**

An asterisk(\*) next to a block type field in the following diagram indicates the message may contain zero or more instances of the series 1 data block.

| Byte                | 0                                    |   |   |   |   |   |   |   | 1                 |   |    |    |    |    |    |    | 2                               |    |    |    |    |    |    |    | 3  |    |    |    |    |    |    |    |
|---------------------|--------------------------------------|---|---|---|---|---|---|---|-------------------|---|----|----|----|----|----|----|---------------------------------|----|----|----|----|----|----|----|----|----|----|----|----|----|----|----|
|                     | 0                                    | 1 | 2 | 3 | 4 | 5 | 6 | 7 | 8                 | 9 | 10 | 11 | 12 | 13 | 14 | 15 | 16                              | 17 | 18 | 19 | 20 | 21 | 22 | 23 | 24 | 25 | 26 | 27 | 28 | 29 | 30 | 31 |
| Bit                 | Host Profile Block Type (132)        |   |   |   |   |   |   |   |                   |   |    |    |    |    |    |    |                                 |    |    |    |    |    |    |    |    |    |    |    |    |    |    |    |
|                     | Host Profile Block Length            |   |   |   |   |   |   |   |                   |   |    |    |    |    |    |    |                                 |    |    |    |    |    |    |    |    |    |    |    |    |    |    |    |
|                     | IP Address                           |   |   |   |   |   |   |   |                   |   |    |    |    |    |    |    |                                 |    |    |    |    |    |    |    |    |    |    |    |    |    |    |    |
| Server Fingerprints | Hops                                 |   |   |   |   |   |   |   | Primary/Secondary |   |    |    |    |    |    |    | Generic List Block Type (31)    |    |    |    |    |    |    |    |    |    |    |    |    |    |    |    |
|                     | Generic List Block Type, continued   |   |   |   |   |   |   |   |                   |   |    |    |    |    |    |    | Generic List Block Length       |    |    |    |    |    |    |    |    |    |    |    |    |    |    |    |
|                     | Generic List Block Length, continued |   |   |   |   |   |   |   |                   |   |    |    |    |    |    |    | Server Fingerprint Data Blocks* |    |    |    |    |    |    |    |    |    |    |    |    |    |    |    |
| Client Fingerprints | Generic List Block Type (31)         |   |   |   |   |   |   |   |                   |   |    |    |    |    |    |    |                                 |    |    |    |    |    |    |    |    |    |    |    |    |    |    |    |
|                     | Generic List Block Length            |   |   |   |   |   |   |   |                   |   |    |    |    |    |    |    |                                 |    |    |    |    |    |    |    |    |    |    |    |    |    |    |    |
|                     | Client Fingerprint Data Blocks*      |   |   |   |   |   |   |   |                   |   |    |    |    |    |    |    |                                 |    |    |    |    |    |    |    |    |    |    |    |    |    |    |    |
| SMB Fingerprints    | Generic List Block Type (31)         |   |   |   |   |   |   |   |                   |   |    |    |    |    |    |    |                                 |    |    |    |    |    |    |    |    |    |    |    |    |    |    |    |
|                     | Generic List Block Length            |   |   |   |   |   |   |   |                   |   |    |    |    |    |    |    |                                 |    |    |    |    |    |    |    |    |    |    |    |    |    |    |    |
|                     | SMB Fingerprint Data Blocks*         |   |   |   |   |   |   |   |                   |   |    |    |    |    |    |    |                                 |    |    |    |    |    |    |    |    |    |    |    |    |    |    |    |

| Byte                       | 0                                      |   |   |   |   |   |   |            | 1 |   |    |    |    |    |    |               | 2  |    |    |    |    |    |    |         | 3  |    |    |    |    |    |    |    |                             |
|----------------------------|----------------------------------------|---|---|---|---|---|---|------------|---|---|----|----|----|----|----|---------------|----|----|----|----|----|----|----|---------|----|----|----|----|----|----|----|----|-----------------------------|
|                            | 0                                      | 1 | 2 | 3 | 4 | 5 | 6 | 7          | 8 | 9 | 10 | 11 | 12 | 13 | 14 | 15            | 16 | 17 | 18 | 19 | 20 | 21 | 22 | 23      | 24 | 25 | 26 | 27 | 28 | 29 | 30 | 31 |                             |
| DHCP Fingerprints          | Generic List Block Type (31)           |   |   |   |   |   |   |            |   |   |    |    |    |    |    |               |    |    |    |    |    |    |    |         |    |    |    |    |    |    |    |    |                             |
|                            | Generic List Block Length              |   |   |   |   |   |   |            |   |   |    |    |    |    |    |               |    |    |    |    |    |    |    |         |    |    |    |    |    |    |    |    |                             |
|                            | DHCP Fingerprint Data Blocks*          |   |   |   |   |   |   |            |   |   |    |    |    |    |    |               |    |    |    |    |    |    |    |         |    |    |    |    |    |    |    |    |                             |
| Mobile Device Fingerprints | Generic List Block Type (31)           |   |   |   |   |   |   |            |   |   |    |    |    |    |    |               |    |    |    |    |    |    |    |         |    |    |    |    |    |    |    |    |                             |
|                            | Generic List Block Length              |   |   |   |   |   |   |            |   |   |    |    |    |    |    |               |    |    |    |    |    |    |    |         |    |    |    |    |    |    |    |    |                             |
|                            | Mobile Device Fingerprint Data Blocks* |   |   |   |   |   |   |            |   |   |    |    |    |    |    |               |    |    |    |    |    |    |    |         |    |    |    |    |    |    |    |    |                             |
| TCP Server Block*          | List Block Type (11)                   |   |   |   |   |   |   |            |   |   |    |    |    |    |    |               |    |    |    |    |    |    |    |         |    |    |    |    |    |    |    |    | List of TCP Servers         |
|                            | List Block Length                      |   |   |   |   |   |   |            |   |   |    |    |    |    |    |               |    |    |    |    |    |    |    |         |    |    |    |    |    |    |    |    |                             |
|                            | TCP Server Data Blocks                 |   |   |   |   |   |   |            |   |   |    |    |    |    |    |               |    |    |    |    |    |    |    |         |    |    |    |    |    |    |    |    |                             |
| UDP Server Block*          | List Block Type (11)                   |   |   |   |   |   |   |            |   |   |    |    |    |    |    |               |    |    |    |    |    |    |    |         |    |    |    |    |    |    |    |    | List of UDP Servers         |
|                            | List Block Length                      |   |   |   |   |   |   |            |   |   |    |    |    |    |    |               |    |    |    |    |    |    |    |         |    |    |    |    |    |    |    |    |                             |
|                            | UDP Server Data Blocks                 |   |   |   |   |   |   |            |   |   |    |    |    |    |    |               |    |    |    |    |    |    |    |         |    |    |    |    |    |    |    |    |                             |
| Network Protocol Block*    | List Block Type (11)                   |   |   |   |   |   |   |            |   |   |    |    |    |    |    |               |    |    |    |    |    |    |    |         |    |    |    |    |    |    |    |    | List of Network Protocols   |
|                            | List Block Length                      |   |   |   |   |   |   |            |   |   |    |    |    |    |    |               |    |    |    |    |    |    |    |         |    |    |    |    |    |    |    |    |                             |
|                            | Network Protocol Data Blocks           |   |   |   |   |   |   |            |   |   |    |    |    |    |    |               |    |    |    |    |    |    |    |         |    |    |    |    |    |    |    |    |                             |
| Transport Protocol Block*  | List Block Type (11)                   |   |   |   |   |   |   |            |   |   |    |    |    |    |    |               |    |    |    |    |    |    |    |         |    |    |    |    |    |    |    |    | List of Transport Protocols |
|                            | List Block Length                      |   |   |   |   |   |   |            |   |   |    |    |    |    |    |               |    |    |    |    |    |    |    |         |    |    |    |    |    |    |    |    |                             |
|                            | Transport Protocol Data Blocks         |   |   |   |   |   |   |            |   |   |    |    |    |    |    |               |    |    |    |    |    |    |    |         |    |    |    |    |    |    |    |    |                             |
| MAC Address Block*         | List Block Type (11)                   |   |   |   |   |   |   |            |   |   |    |    |    |    |    |               |    |    |    |    |    |    |    |         |    |    |    |    |    |    |    |    | List of MAC Addresses       |
|                            | List Block Length                      |   |   |   |   |   |   |            |   |   |    |    |    |    |    |               |    |    |    |    |    |    |    |         |    |    |    |    |    |    |    |    |                             |
|                            | Host MAC Address Data Blocks           |   |   |   |   |   |   |            |   |   |    |    |    |    |    |               |    |    |    |    |    |    |    |         |    |    |    |    |    |    |    |    |                             |
| Host Last Seen             |                                        |   |   |   |   |   |   |            |   |   |    |    |    |    |    |               |    |    |    |    |    |    |    |         |    |    |    |    |    |    |    |    |                             |
| Host Type                  |                                        |   |   |   |   |   |   |            |   |   |    |    |    |    |    |               |    |    |    |    |    |    |    |         |    |    |    |    |    |    |    |    |                             |
| Mobile                     |                                        |   |   |   |   |   |   | Jailbroken |   |   |    |    |    |    |    | VLAN Presence |    |    |    |    |    |    |    | VLAN ID |    |    |    |    |    |    |    |    |                             |

| Byte            | 0                                   |   |   |   |   |   |   |   | 1         |   |    |    |    |    |    |    | 2                              |    |    |    |    |    |    |    | 3                            |    |    |    |    |    |    |    |                             |
|-----------------|-------------------------------------|---|---|---|---|---|---|---|-----------|---|----|----|----|----|----|----|--------------------------------|----|----|----|----|----|----|----|------------------------------|----|----|----|----|----|----|----|-----------------------------|
|                 | 0                                   | 1 | 2 | 3 | 4 | 5 | 6 | 7 | 8         | 9 | 10 | 11 | 12 | 13 | 14 | 15 | 16                             | 17 | 18 | 19 | 20 | 21 | 22 | 23 | 24                           | 25 | 26 | 27 | 28 | 29 | 30 | 31 |                             |
| Client App Data | VLAN ID, cont.                      |   |   |   |   |   |   |   | VLAN Type |   |    |    |    |    |    |    | VLAN Priority                  |    |    |    |    |    |    |    | Generic List Block Type (31) |    |    |    |    |    |    |    | List of Client Applications |
|                 | Generic List Block Type (31), cont. |   |   |   |   |   |   |   |           |   |    |    |    |    |    |    | Generic List Block Length      |    |    |    |    |    |    |    |                              |    |    |    |    |    |    |    |                             |
|                 | Generic List Block Length, cont.    |   |   |   |   |   |   |   |           |   |    |    |    |    |    |    | Client Application Data Blocks |    |    |    |    |    |    |    |                              |    |    |    |    |    |    |    |                             |
| NetBIOS Name    | String Block Type (0)               |   |   |   |   |   |   |   |           |   |    |    |    |    |    |    |                                |    |    |    |    |    |    |    |                              |    |    |    |    |    |    |    |                             |
|                 | String Block Length                 |   |   |   |   |   |   |   |           |   |    |    |    |    |    |    |                                |    |    |    |    |    |    |    |                              |    |    |    |    |    |    |    |                             |
|                 | NetBIOS String Data...              |   |   |   |   |   |   |   |           |   |    |    |    |    |    |    |                                |    |    |    |    |    |    |    |                              |    |    |    |    |    |    |    |                             |

The following table describes the fields of the host profile data block returned by version 5.1.x

**Table B-34** Host Profile Data Block 5.1.x Fields

| Field                                                           | Data Type | Description                                                                                                                                                                                                                                                     |
|-----------------------------------------------------------------|-----------|-----------------------------------------------------------------------------------------------------------------------------------------------------------------------------------------------------------------------------------------------------------------|
| Host Profile Block Type                                         | uint32    | Initiates the Host Profile data block for 5.1.x. This value is always 132.                                                                                                                                                                                      |
| Host Profile Block Length                                       | uint32    | Number of bytes in the Host Profile data block, including eight bytes for the host profile block type and length fields, plus the number of bytes included in the host profile data that follows.                                                               |
| IP Address                                                      | uint8[4]  | IP address of the host described in the profile, in IP address octets.                                                                                                                                                                                          |
| Hops                                                            | uint8     | Number of hops from the host to the device.                                                                                                                                                                                                                     |
| Primary/Secondary                                               | uint8     | Indicates whether the host is in the primary or secondary network of the device that detected it: <ul style="list-style-type: none"> <li>0 - host is in the primary network.</li> <li>1 - host is in the secondary network.</li> </ul>                          |
| Generic List Block Type                                         | uint32    | Initiates a Generic List data block comprising Operating System Fingerprint data blocks conveying fingerprint data identified using a server fingerprint. This value is always 31.                                                                              |
| Generic List Block Length                                       | uint32    | Number of bytes in the Generic List data block, including the list header and all encapsulated Operating System Fingerprint data blocks.                                                                                                                        |
| Operating System Fingerprint (Server Fingerprint) Data Blocks * | variable  | Operating System Fingerprint data blocks containing information about the operating system on a host identified using a server fingerprint. See <a href="#">Operating System Fingerprint Data Block 5.1+</a> , page 4-141 for a description of this data block. |

Table B-34 Host Profile Data Block 5.1.x Fields (continued)

| Field                                                           | Data Type | Description                                                                                                                                                                                                                                                                     |
|-----------------------------------------------------------------|-----------|---------------------------------------------------------------------------------------------------------------------------------------------------------------------------------------------------------------------------------------------------------------------------------|
| Generic List Block Type                                         | uint32    | Initiates a Generic List data block comprising Operating System Fingerprint data blocks conveying fingerprint data identified using a client fingerprint. This value is always 31.                                                                                              |
| Generic List Block Length                                       | uint32    | Number of bytes in the Generic List data block, including the list header and all encapsulated Operating System Fingerprint data blocks.                                                                                                                                        |
| Operating System Fingerprint (Client Fingerprint) Data Blocks * | variable  | Operating System Fingerprint data blocks containing information about the operating system on a host identified using a client fingerprint. See <a href="#">Operating System Fingerprint Data Block 5.1+</a> , <a href="#">page 4-141</a> for a description of this data block. |
| Generic List Block Type                                         | uint32    | Initiates a Generic List data block comprising Operating System Fingerprint data blocks conveying fingerprint data identified using an SMB fingerprint. This value is always 31.                                                                                                |
| Generic List Block Length                                       | uint32    | Number of bytes in the Generic List data block, including the list header and all encapsulated Operating System Fingerprint data blocks.                                                                                                                                        |
| Operating System Fingerprint (SMB Fingerprint) Data Blocks *    | variable  | Operating System Fingerprint data blocks containing information about the operating system on a host identified using an SMB fingerprint. See <a href="#">Operating System Fingerprint Data Block 5.1+</a> , <a href="#">page 4-141</a> for a description of this data block.   |
| Generic List Block Type                                         | uint32    | Initiates a Generic List data block comprising Operating System Fingerprint data blocks conveying fingerprint data identified using a DHCP fingerprint. This value is always 31.                                                                                                |
| Generic List Block Length                                       | uint32    | Number of bytes in the Generic List data block, including the list header and all encapsulated Operating System Fingerprint data blocks.                                                                                                                                        |
| Operating System Fingerprint (DHCP Fingerprint) Data Blocks *   | variable  | Operating System Fingerprint data blocks containing information about the operating system on a host identified using a DHCP fingerprint. See <a href="#">Operating System Fingerprint Data Block 5.1+</a> , <a href="#">page 4-141</a> for a description of this data block.   |
| Generic List Block Type                                         | uint32    | Initiates a Generic List data block comprising Operating System Fingerprint data blocks conveying fingerprint data identified using a DHCP fingerprint. This value is always 31.                                                                                                |
| Generic List Block Length                                       | uint32    | Number of bytes in the Generic List data block, including the list header and all encapsulated Operating System Fingerprint data blocks.                                                                                                                                        |

Table B-34 Host Profile Data Block 5.1.x Fields (continued)

| Field                                                                  | Data Type | Description                                                                                                                                                                                                                                                            |
|------------------------------------------------------------------------|-----------|------------------------------------------------------------------------------------------------------------------------------------------------------------------------------------------------------------------------------------------------------------------------|
| Operating System Fingerprint (Mobile Device Fingerprint) Data Blocks * | variable  | Operating System Fingerprint data blocks containing information about the operating system on a host identified using a mobile device fingerprint. See <a href="#">Operating System Fingerprint Data Block 5.1+</a> , page 4-141 for a description of this data block. |
| List Block Type                                                        | uint32    | Initiates a List data block comprising Server data blocks conveying TCP server data. This value is always 11.                                                                                                                                                          |
| List Block Length                                                      | uint32    | Number of bytes in the list. This number includes the eight bytes of the list block type and length fields, plus all encapsulated Server data blocks.<br><br>This field is followed by zero or more Server data blocks.                                                |
| TCP Server Data Blocks                                                 | variable  | Host server data blocks describing a TCP server (as documented for earlier versions of the product).                                                                                                                                                                   |
| List Block Type                                                        | uint32    | Initiates a List data block comprising Server data blocks conveying UDP server data. This value is always 11.                                                                                                                                                          |
| List Block Length                                                      | uint32    | Number of bytes in the list. This number includes the eight bytes of the list block type and length fields, plus all encapsulated Server data blocks.<br><br>This field is followed by zero or more Server data blocks.                                                |
| UDP Server Data Blocks                                                 | uint32    | Host server data blocks describing a UDP server (as documented for earlier versions of the product).                                                                                                                                                                   |
| List Block Type                                                        | uint32    | Initiates a List data block comprising Protocol data blocks conveying network protocol data. This value is always 11.                                                                                                                                                  |
| List Block Length                                                      | uint32    | Number of bytes in the list. This number includes the eight bytes of the list block type and length fields, plus all encapsulated Protocol data blocks.<br><br>This field is followed by zero or more Protocol data blocks.                                            |
| Network Protocol Data Blocks                                           | uint32    | Protocol data blocks describing a network protocol. See <a href="#">Protocol Data Block</a> , page 4-68 for a description of this data block.                                                                                                                          |
| List Block Type                                                        | uint32    | Initiates a List data block comprising Protocol data blocks conveying transport protocol data. This value is always 11.                                                                                                                                                |
| List Block Length                                                      | uint32    | Number of bytes in the list. This number includes the eight bytes of the list block type and length fields, plus all encapsulated Protocol data blocks.<br><br>This field is followed by zero or more transport protocol data blocks.                                  |
| Transport Protocol Data Blocks                                         | uint32    | Protocol data blocks describing a transport protocol. See <a href="#">Protocol Data Block</a> , page 4-68 for a description of this data block.                                                                                                                        |
| List Block Type                                                        | uint32    | Initiates a List data block comprising MAC Address data blocks. This value is always 11.                                                                                                                                                                               |
| List Block Length                                                      | uint32    | Number of bytes in the list, including the list header and all encapsulated MAC Address data blocks.                                                                                                                                                                   |

Table B-34 Host Profile Data Block 5.1.x Fields (continued)

| Field                          | Data Type | Description                                                                                                                                                                                                                    |
|--------------------------------|-----------|--------------------------------------------------------------------------------------------------------------------------------------------------------------------------------------------------------------------------------|
| Host MAC Address Data Blocks   | uint32    | Host MAC Address data blocks describing a host MAC address. See <a href="#">Host MAC Address 4.9+, page 4-108</a> for a description of this data block.                                                                        |
| Host Last Seen                 | uint32    | UNIX timestamp that represents the last time the system detected host activity.                                                                                                                                                |
| Host Type                      | uint32    | Indicates the host type. The following values may appear: <ul style="list-style-type: none"> <li>• 0 - host</li> <li>• 1 - router</li> <li>• 2 - bridge</li> <li>• 3 - NAT device</li> <li>• 4 - LB (load balancer)</li> </ul> |
| Mobile                         | uint8     | True-false flag indicating whether the host is a mobile device.                                                                                                                                                                |
| Jailbroken                     | uint8     | True-false flag indicating whether the host is a mobile device that is also jailbroken.                                                                                                                                        |
| VLAN Presence                  | uint8     | Indicates whether a VLAN is present: <ul style="list-style-type: none"> <li>• 0 - Yes</li> <li>• 1 - No</li> </ul>                                                                                                             |
| VLAN ID                        | uint16    | VLAN identification number that indicates which VLAN the host is a member of.                                                                                                                                                  |
| VLAN Type                      | uint8     | Type of packet encapsulated in the VLAN tag.                                                                                                                                                                                   |
| VLAN Priority                  | uint8     | Priority value included in the VLAN tag.                                                                                                                                                                                       |
| Generic List Block Type        | uint32    | Initiates a Generic List data block comprising Client Application data blocks conveying client application data. This value is always 31.                                                                                      |
| Generic List Block Length      | uint32    | Number of bytes in the Generic List data block, including the list header and all encapsulated client application data blocks.                                                                                                 |
| Client Application Data Blocks | uint32    | Client application data blocks describing a client application. See <a href="#">Full Host Client Application Data Block 5.0+, page 4-136</a> for a description of this data block.                                             |
| String Block Type              | uint32    | Initiates a string data block for the NetBIOS name. This value is set to 0 to indicate string data.                                                                                                                            |
| String Block Length            | uint32    | Indicates the number of bytes in the NetBIOS name data block, including eight bytes for the string block type and length, plus the number of bytes in the NetBIOS name.                                                        |
| NetBIOS String Data            | Variable  | Contains the NetBIOS name of the host described in the host profile.                                                                                                                                                           |

## IP Range Specification Data Block for 5.0 - 5.1.1.x

The IP Range Specification data block conveys a range of IP addresses. IP Range Specification data blocks are used in User Protocol, User Client Application, Address Specification, User Product, User Server, User Hosts, User Vulnerability, User Criticality, and User Attribute Value data blocks. The IP Range Specification data block has a block type of 61.

The following diagram shows the format of the IP Range Specification data block:

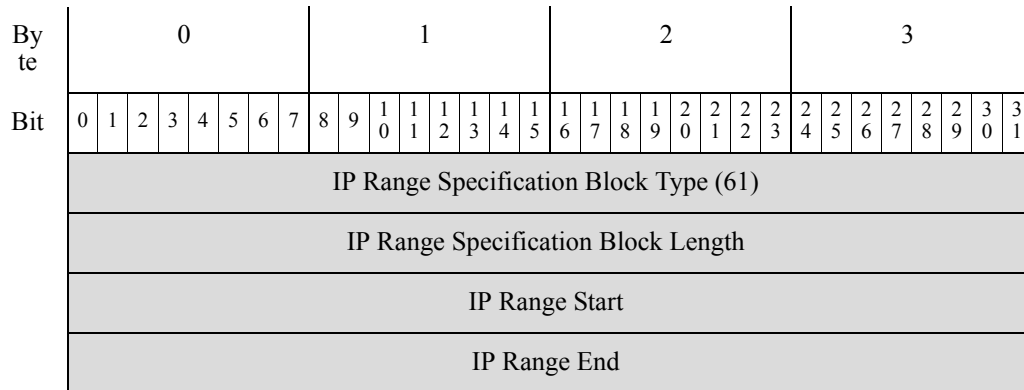

The following table describes the components of the IP Range Specification data block.

**Table B-35** IP Range Specification Data Block Fields

| Field                               | Data Type | Description                                                                                                                                                                                                              |
|-------------------------------------|-----------|--------------------------------------------------------------------------------------------------------------------------------------------------------------------------------------------------------------------------|
| IP Range Specification Block Type   | uint32    | Initiates a IP Range Specification data block. This value is always 61.                                                                                                                                                  |
| IP Range Specification Block Length | uint32    | Total number of bytes in the IP Range Specification data block, including eight bytes for the IP Range Specification block type and length fields, plus the number of bytes of IP range specification data that follows. |
| IP Range Specification Start        | uint32    | The starting IP address for the IP address range.                                                                                                                                                                        |
| IP Range Specification End          | uint32    | The ending IP address for the IP address range.                                                                                                                                                                          |





## INDEX

---

### A

Access Control Policy Name record [3-27](#)  
Access Control Rule Action record [4-21](#)  
Access Control Rule data block [4-173](#)  
Access Control Rule ID record [3-28](#)  
Access Control Rule Reason data block 5.1+ [4-174](#)  
Access Control Rule Reason record [4-24](#)  
Add Client Application message [4-52](#)  
Add Host Attribute message [4-50](#)  
Additional MAC Detected for Host message [4-43](#)  
Add Protocol message [4-51](#)  
Address Specification data block [4-92](#)  
Add Scan Result message [4-52](#)  
Attribute Address data block [4-73](#)  
Attribute Definition data block  
    4.7+ [4-80](#)  
Attribute List Item data block [4-74](#)  
Attribute record [4-13](#)  
Attribute Specification data block [4-89](#)  
Attribute Value data block [4-75](#)

---

### B

BLOB data block  
    series 1 [4-64](#)  
    series 2 [3-48](#)

---

### C

Change NetBIOS Name message [4-45](#)  
Classification record  
    4.6.1+ [3-17](#)

Client Application messages [4-40](#)  
Client Application record [4-8](#)  
Connection Chunk data block [4-93, B-94](#)  
Connection Chunk message [4-47](#)  
Connection Event message format [2-20](#)  
Connection Statistics data block  
    5.0+ [B-78](#)  
    5.1.1+ [4-111, B-89, B-102](#)  
    5.1+ [4-111, B-83, B-89, B-96, B-102](#)  
Connection Statistics Data message [4-46](#)  
Correlation Event message format [2-20](#)  
Correlation Event record  
    5.0+ [3-36](#)  
    5.0 - 5.0.2 [B-123](#)  
Correlation Policy record [3-18](#)  
Correlation record header format [2-21](#)  
Correlation Rule record [3-20](#)  
Criticality record data structure [4-11](#)

---

### D

Data Block header format [2-24](#)  
Delete Client Application message [4-52](#)  
Delete Host Attribute message [4-50](#)  
Delete Protocol message [4-51](#)  
Discovery Event header 4.8.0.2+ [4-32, B-55](#)  
Discovery Event message format [2-19](#)  
Discovery Event message header [2-19](#)

---

### E

Error message format [2-8](#)  
eStreamer message header format [2-7](#)

Event Data message format [2-17](#)  
 Event Extra Data message format [2-22](#)  
 Event Stream Request message format [2-10](#)  
 example  
   Classification record [A-8](#)  
   Correlation Event record 4.10 [A-13](#)  
   Error message format [2-9](#)  
   Intrusion Event record 3.2+ [A-1](#)  
   Intrusion Impact Alert record [A-6](#)  
   New Network Protocol message [A-16](#)  
   New TCP Server message [A-18](#)  
   Null message format [2-8](#)  
   Packet record [A-7](#)  
   Priority record [A-10](#)  
   Rule Message record [A-11](#)  
   Streaming Information message format [2-34](#)  
   Streaming Service Request message [2-35](#)

---

## F

File Event for 5.1.1+ [3-52](#)  
 File Event SHA Hash for 5.1.1+ [3-72](#), [B-116](#)  
 Fingerprint record [4-7](#)  
 FireAMP Cloud Name record [3-31](#)  
 FireAMP Event data block 5.1 [B-32](#)  
 FireAMP Event data block 5.1+ [3-64](#), [B-36](#), [B-42](#), [B-48](#)  
 FireAMP Event Type record [4-31](#)  
 Fix List data block [4-95](#)  
 Full Host Client Application data block  
   5.0+ [4-136](#)  
 Full Host Client Application data block 5.0+ [4-136](#)  
 Full Host Profile data block  
   5.0+ [5-1](#)  
   5.0 - 5.0.2 [B-131](#)  
   5.1+ [5-1](#), [B-140](#), [B-149](#)  
 Full Host Server data block 4.10.0+ [4-122](#)  
 Full Server Information data block [4-128](#)  
 Full Sub-Server data block [4-77](#)

---

## G

Generic List data block  
   series 1 [4-66](#)  
   series 2 [3-50](#)  
 Generic Scan Results data block  
   4.10.0+ [4-131](#)

---

## H

Hops Change message [4-43](#)  
 Host Attribute messages [4-50](#)  
 Host Attribute Value messages [4-50](#)  
 Host Client Application data block  
   5.0+ [4-137](#)  
 Host Data message format [2-27](#)  
 Host Deleted: Host Limit Reached message [4-42](#)  
 Host Dropped: Host Limit Reached message [4-42](#)  
 Host Identified as a Bridge/Router message [4-44](#)  
 Host IP Address Changed message [4-40](#)  
 Host IP Address Reused message [4-42](#)  
 Host Last Seen message [4-37](#)  
 Host MAC Address data block 4.9+ [4-108](#)  
 Host Profile data block 4.9+ [4-144](#), [B-161](#)  
 Host Request message format [2-24](#)  
 Host Server data block  
   4.10.0+ [4-120](#)  
 Host Timeout message [4-42](#)  
 Host Vulnerability data block  
   4.9.0+ [4-105](#)

---

## I

Identity Conflict message [4-53](#)  
 Identity data block [4-106](#)  
 Identity Timeout message [4-53](#)  
 Integer (INT32) data block [4-69](#)  
 Interface Name record [3-26](#)  
 Intrusion Event Extra Data Metadata record [3-23](#)

Intrusion Event Extra Data record [3-21](#)  
 Intrusion Event message format [2-18](#)  
 Intrusion Event record  
     5.0.x - 5.1 (IPv6) [B-6](#)  
     5.0+ (IPv4) [3-6, B-2, B-11, B-17, B-24](#)  
 Intrusion Event Record 5.1.1+ [3-6, B-11, B-17, B-29](#)  
 Intrusion Impact Alert record [3-12, B-29](#)  
 Intrusion Policy Name record [4-20](#)  
 IP Address Change message [4-40](#)  
 IP Range Specification data block [4-88, B-167](#)

---

## L

List data block  
     series 1 [4-65](#)  
     series 2 [3-49](#)

---

## M

MAC Address messages [4-43](#)  
 MAC Address Specification data block [4-90, 4-91](#)  
 MAC Information Change message [4-43](#)  
 Malware Event Data Block 5.1.1+ [3-64](#)  
 Malware Event Record 5.1.1+ [3-30](#)  
 Message bundle format [2-35](#)  
 Metadata message format [2-18](#)  
 Mobile Device Information data block 5.1+ [4-143](#)  
 Multiple Host Data message format [2-27](#)

---

## N

Network Protocol record [4-12](#)  
 New Host message [4-37](#)  
 New IP to IP Traffic message [4-40](#)  
 New Network Protocol message [4-39](#)  
 New TCP Server message [4-38](#)  
 New UDP Server message [4-38](#)  
 Null message format [2-7](#)

---

## O

Operating System data block 3.5+ [4-79](#)  
 Operating System Fingerprint data block  
     4.9.x-5.0.2 [B-77](#)  
     5.1+ [4-141](#)  
 Operating System Fingerprint data block 5.1+ [4-141](#)  
 OS Confidence Update message [4-41](#)  
 OS Information Update message [4-41](#)

---

## P

Packet record data structure  
     4.8.0.2+ [3-4](#)  
 Policy Control message [4-46](#)  
 Policy Engine Control Message data block [4-79](#)  
 Priority record [3-5](#)  
 Protocol data block [4-68](#)

---

## R

Request Flags format [2-11](#)  
 Rule Message record data structure 4.6.1+ [3-16](#)

---

## S

Scan Result data block  
     4.10.0+ [4-118, B-60](#)  
 Scan Type record [4-13](#)  
 Scan Vulnerability data block  
     4.10.0+ [4-133](#)  
 Secondary Host Update data block [4-109](#)  
 Security Intelligence Category data block 5.1+ [4-175](#)  
 Security Intelligence Category record [4-29](#)  
 Security Zone Name record [3-25](#)  
 Sensor record [3-30](#)  
 Server Information data block  
     4.10.x,5.0 - 5.0.2 [4-126](#)

Server messages [4-38](#)  
 Server record [4-14](#)  
 Service Banner data block [4-72](#)  
 Source Application record [4-16](#)  
 Source Detector record [4-16](#)  
 Source Type record [4-15](#)  
 Streaming Event Type [2-32](#)  
 Streaming Information message format [2-29](#)  
 Streaming Request message format [2-30](#)  
 Streaming Service Request [2-30](#)  
 Streaming Service Request data structure [2-30](#)  
 String data block  
     series 1 [4-63](#)  
     series 2 [3-48](#)  
 String Information data block [4-73](#)  
 Sub-Server data block [4-66](#)

---

## T

TCP Port Closed message [4-43](#)  
 TCP Port Timeout message [4-43](#)  
 TCP Server Confidence Update message [4-38](#)  
 TCP Server Information Update message [4-38](#)  
 Third Party Scanner Vulnerability record [4-17](#)

---

## U

UDP Port Closed message [4-43](#)  
 UDP Port Timeout message [4-43](#)  
 UDP Server Confidence Update message [4-38](#)  
 UDP Server Information Update message [4-38](#)  
 Update Banner message [4-45](#)  
 Update Host Attribute message [4-50](#)  
 URL Category record [4-22](#)  
 URL Reputation record [4-23](#)  
 User Account Update message data block [4-160](#)  
 User Add Hosts message [4-48](#)  
 User Attribute Value data block 4.7+ [4-102](#)

User Client Application data block [4-85, B-58](#)  
 User Client Application List data block [4-86](#)  
 User Criticality Change data block 4.7+ [4-101](#)  
 User data block [4-159](#)  
 User Delete Address message [4-48](#)  
 User Delete Server message [4-49](#)  
 User Hosts data block 4.7+ [4-98](#)  
 User Information data block [4-168](#)  
 User Information Update message [4-54](#)  
 User Login Information data block  
     5.0-5.0.2 [B-68](#)  
     5.1+ [4-171](#)  
 User Modification message [4-54](#)  
 User Product data block  
     4.10.x,5.0-5.0.2 [B-62](#)  
     5.1+ [4-152](#)  
 User Protocol data block [4-83](#)  
 User Protocol List data block 4.7+ [4-104](#)  
 User record [3-15, 4-18](#)  
 User Server data block [4-95](#)  
 User Server List data block [4-97](#)  
 User Set Host Criticality message [4-49](#)  
 User Set Invalid Vulnerabilities message 4.6.1+ [4-47](#)  
 User Set Valid Vulnerabilities message 4.6.1+ [4-47](#)  
 User Vulnerability Change data block 4.7+ [4-99](#)  
 User Vulnerability data block  
     5.0+ [4-139](#)  
 User Vulnerability Qualification message 4.6.1+ [4-47](#)  
 UUID String Mapping data block [3-51, 3-52, 3-53, 3-54, 3-55, 3-56](#)

---

## V

VLAN data block [4-71](#)  
 VLAN Tag Information Update message [4-44](#)  
 Vulnerability record [4-9](#)  
 Vulnerability Reference data block [4-69](#)

---

**W**

Web Application data block

5.0+ [4-110](#)

Web Application record [4-19](#)

