



# **Cisco 5100 Enterprise Network Compute System Hardware Installation Guide**

**First Published:** 2017-09-25

## **Americas Headquarters**

Cisco Systems, Inc.  
170 West Tasman Drive  
San Jose, CA 95134-1706  
USA  
<http://www.cisco.com>  
Tel: 408 526-4000  
800 553-NETS (6387)  
Fax: 408 527-0883

THE SPECIFICATIONS AND INFORMATION REGARDING THE PRODUCTS IN THIS MANUAL ARE SUBJECT TO CHANGE WITHOUT NOTICE. ALL STATEMENTS, INFORMATION, AND RECOMMENDATIONS IN THIS MANUAL ARE BELIEVED TO BE ACCURATE BUT ARE PRESENTED WITHOUT WARRANTY OF ANY KIND, EXPRESS OR IMPLIED. USERS MUST TAKE FULL RESPONSIBILITY FOR THEIR APPLICATION OF ANY PRODUCTS.

THE SOFTWARE LICENSE AND LIMITED WARRANTY FOR THE ACCOMPANYING PRODUCT ARE SET FORTH IN THE INFORMATION PACKET THAT SHIPPED WITH THE PRODUCT AND ARE INCORPORATED HEREIN BY THIS REFERENCE. IF YOU ARE UNABLE TO LOCATE THE SOFTWARE LICENSE OR LIMITED WARRANTY, CONTACT YOUR CISCO REPRESENTATIVE FOR A COPY.

The following information is for FCC compliance of Class A devices: This equipment has been tested and found to comply with the limits for a Class A digital device, pursuant to part 15 of the FCC rules. These limits are designed to provide reasonable protection against harmful interference when the equipment is operated in a commercial environment. This equipment generates, uses, and can radiate radio-frequency energy and, if not installed and used in accordance with the instruction manual, may cause harmful interference to radio communications. Operation of this equipment in a residential area is likely to cause harmful interference, in which case users will be required to correct the interference at their own expense.

The following information is for FCC compliance of Class B devices: This equipment has been tested and found to comply with the limits for a Class B digital device, pursuant to part 15 of the FCC rules. These limits are designed to provide reasonable protection against harmful interference in a residential installation. This equipment generates, uses and can radiate radio frequency energy and, if not installed and used in accordance with the instructions, may cause harmful interference to radio communications. However, there is no guarantee that interference will not occur in a particular installation. If the equipment causes interference to radio or television reception, which can be determined by turning the equipment off and on, users are encouraged to try to correct the interference by using one or more of the following measures:

- Reorient or relocate the receiving antenna.
- Increase the separation between the equipment and receiver.
- Connect the equipment into an outlet on a circuit different from that to which the receiver is connected.
- Consult the dealer or an experienced radio/TV technician for help.

Modifications to this product not authorized by Cisco could void the FCC approval and negate your authority to operate the product.

The Cisco implementation of TCP header compression is an adaptation of a program developed by the University of California, Berkeley (UCB) as part of UCB's public domain version of the UNIX operating system. All rights reserved. Copyright © 1981, Regents of the University of California.

NOTWITHSTANDING ANY OTHER WARRANTY HEREIN, ALL DOCUMENT FILES AND SOFTWARE OF THESE SUPPLIERS ARE PROVIDED "AS IS" WITH ALL FAULTS. CISCO AND THE ABOVE-NAMED SUPPLIERS DISCLAIM ALL WARRANTIES, EXPRESSED OR IMPLIED, INCLUDING, WITHOUT LIMITATION, THOSE OF MERCHANTABILITY, FITNESS FOR A PARTICULAR PURPOSE AND NON-INFRINGEMENT OR ARISING FROM A COURSE OF DEALING, USAGE, OR TRADE PRACTICE.

IN NO EVENT SHALL CISCO OR ITS SUPPLIERS BE LIABLE FOR ANY INDIRECT, SPECIAL, CONSEQUENTIAL, OR INCIDENTAL DAMAGES, INCLUDING, WITHOUT LIMITATION, LOST PROFITS OR LOSS OR DAMAGE TO DATA ARISING OUT OF THE USE OR INABILITY TO USE THIS MANUAL, EVEN IF CISCO OR ITS SUPPLIERS HAVE BEEN ADVISED OF THE POSSIBILITY OF SUCH DAMAGES.

Any Internet Protocol (IP) addresses and phone numbers used in this document are not intended to be actual addresses and phone numbers. Any examples, command display output, network topology diagrams, and other figures included in the document are shown for illustrative purposes only. Any use of actual IP addresses or phone numbers in illustrative content is unintentional and coincidental.

All printed copies and duplicate soft copies of this document are considered uncontrolled. See the current online version for the latest version.

Cisco has more than 200 offices worldwide. Addresses and phone numbers are listed on the Cisco website at [www.cisco.com/go/offices](http://www.cisco.com/go/offices).

Cisco and the Cisco logo are trademarks or registered trademarks of Cisco and/or its affiliates in the U.S. and other countries. To view a list of Cisco trademarks, go to this URL: <https://www.cisco.com/c/en/us/about/legal/trademarks.html>. Third-party trademarks mentioned are the property of their respective owners. The use of the word partner does not imply a partnership relationship between Cisco and any other company. (1721R)

© 2017 Cisco Systems, Inc. All rights reserved.



## CONTENTS

---

### PREFACE

#### **Preface** v

Audience v

Related Documentation v

Obtaining Documentation and Submitting a Service Request v

---

### CHAPTER 1

#### **Overview of the Cisco 5100 Enterprise Network Compute System** 1

Cisco 5100 Series Enterprise Network Compute System Chassis 1

Chassis - Front Panel 1

Chassis - Bezel Side 2

Chassis - Internal 2

Hardware Features - Standard 2

Hardware Features 6

Models 7

SFP Modules 7

---

### CHAPTER 2

#### **Preparing for Installation** 9

Safety Recommendations and Warnings 9

Safety with Electricity 10

Site Requirements 11

Mounting Requirements 12

Power Guidelines and Requirements 13

Network Cabling Specification 13

Required Tools and Equipment 13

---

### CHAPTER 3

#### **Installing the Device** 15

Unpacking the Device 15

Installing the Cisco 5100 ENCS	15
Rack-Mounting the Chassis	15
Wall-Mounting the Chassis	17
Grounding the Chassis	18
Powering On the Server	19
Initial Server Setup	19

---

<b>CHAPTER 4</b>	<b>Installing and Upgrading Field Replaceable Units</b>	<b>21</b>
	Removing and Replacing the Chassis Cover	21
	Installing a DIMM	22
	Removing a DIMM	24
	Upgrading the M.2 Storage Module	25



## Preface

---

This preface describes the audience, and provides information about how to obtain related documentation.

- [Audience, on page v](#)
- [Related Documentation, on page v](#)
- [Obtaining Documentation and Submitting a Service Request, on page v](#)

## Audience

This guide is intended for Cisco equipment providers and service persons who are technically knowledgeable and familiar with Cisco hardware devices. This guide identifies certain procedures that should be performed only by trained and qualified personnel.

## Related Documentation

- Cisco Enterprise Network Function Virtualization Infrastructure Software (NFVIS) Configuration Guide
- API Reference for Cisco Enterprise Network Function Virtualization Infrastructure Software

## Obtaining Documentation and Submitting a Service Request

For information on obtaining documentation, using the Cisco Bug Search Tool (BST), submitting a service request, and gathering additional information, see [What's New in Cisco Product Documentation](#).

To receive new and revised Cisco technical content directly to your desktop, you can subscribe to the [What's New in Cisco Product Documentation RSS feed](#). RSS feeds are a free service.





# CHAPTER 1

## Overview of the Cisco 5100 Enterprise Network Compute System

The Cisco 5100 Enterprise Network Compute System (ENCS) combines routing, switching, storage, processing, and a host of other computing and networking activities into a compact one Rack Unit (RU) box. This high-performance unit achieves this goal by providing the infrastructure to deploy virtualized network functions while at the same time acting as a server that addresses processing, workload, and storage challenges.

- [Cisco 5100 Series Enterprise Network Compute System Chassis, on page 1](#)
- [Hardware Features - Standard, on page 2](#)
- [Hardware Features, on page 6](#)
- [Models, on page 7](#)
- [SFP Modules, on page 7](#)

## Cisco 5100 Series Enterprise Network Compute System Chassis

### Chassis - Front Panel

Figure 1: Front Panel of the Cisco 5100 ENCS

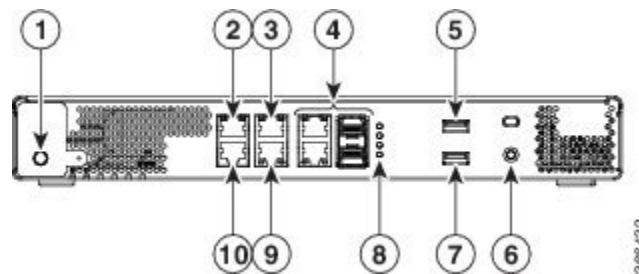

1.	Power on/standby switch	2	Ethernet management port
3	Front panel Gigabit Ethernet ports GE0-2	4	Front panel Gigabit Ethernet combo ports GE0-0 and GE0-1
5	USB	6	Ground

7	USB	8	LEDs for front panel Gigabit Ethernet ports
9	Front panel Gigabit Ethernet ports GE0-3	10	Serial console port

## Chassis - Bezel Side

Figure 2: Bezel View of the Cisco 5100 ENCS



## Chassis - Internal

Figure 3: Internal View of the Cisco 5100 ENCS

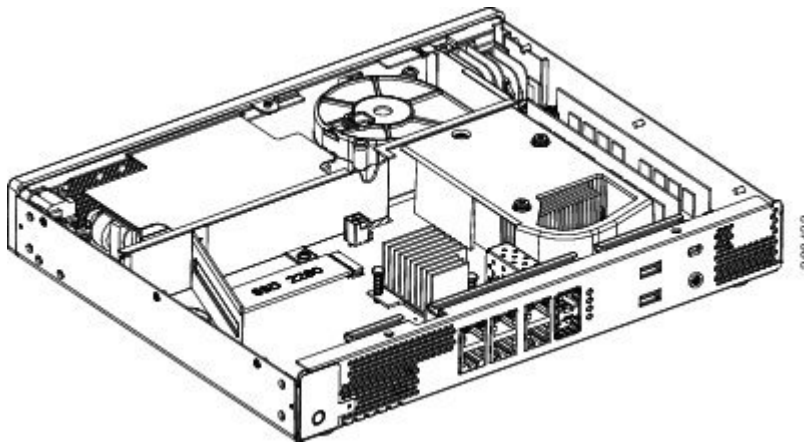

## Hardware Features - Standard

- **USB 3.0 port:** You can use this port to connect a mouse, keyboard, or any other USB device. Using a USB hub, you can connect more than one USB device to this port. Because this port is backward compatible, you can also use an older version of USB devices on this port.
- **Ethernet management port for CPU:** Use this port to connect to the CPU in your device.
- **Front panel Gigabit Ethernet ports:** There are a set of two dual ports GE0-0 and GE0-1. For those RJ45 ports, there is a corresponding fiber optic port. At a given time, the user can use either the RJ45 connection or the corresponding fiber optic port. There are a set of two copper ports GE0-2 and GE0-3. Those two ports support copper RJ45 only.



### Warning

For connections outside the building where the equipment is installed, the following ports must be connected through an approved network termination unit with integral circuit protection: Gigabit Ethernet (GE). Statement 1044.



- **Serial console port:** This serial port provides a connection to initially configure the main system's CPU, including the NFVIS software that runs there, using a traditional serial terminal. The terminal should be configured for 9600 8-N-1.



**Note** The speed and duplex configurations are dependent on the peer configuration. If the peer is set at a certain speed and duplex, NFVIS port is set to match that speed. Not all ports on ENCS 5000 series hardware devices support Automatic medium-dependent interface crossover (auto-MDIX) feature. Based on the port connected to the ENCS device, the cable type used to connect to the peer and the speed or duplex settings on the peer, you can try straight through and cross over cable.

**LEDs for Gigabit Ethernet Ports**

The front panel Gigabit Ethernet ports (numbered 4 in Figure 1) are a set of two dual ports: for every RJ45 port, there is a corresponding fiber optic port. There are four LEDs for the front panel Gigabit Ethernet ports (numbered 8 in Figure 1). The first two LEDs are for the first set of ports and the last two LEDs are for the second set of ports. If both RJ45 and fiber optic ports are enabled when the system boots, the fiber optic port is used and the RJ45 port is disabled.

*Figure 4: LEDs for Gigabit Ethernet Ports*

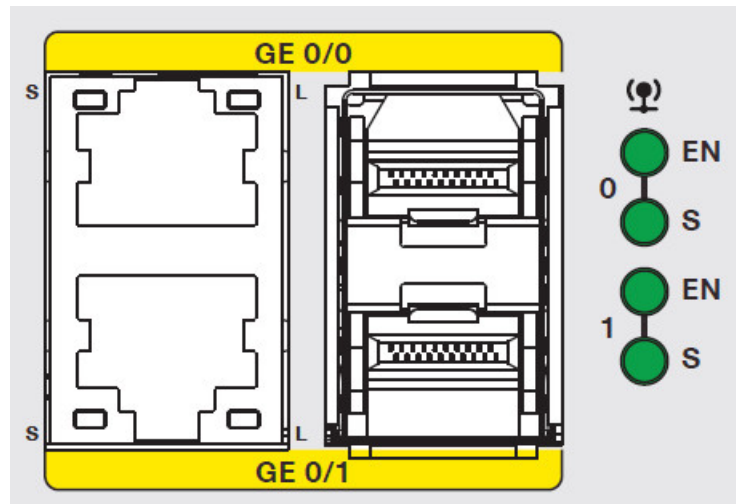

The LEDs labeled **EN** indicates whether the corresponding ports are enabled.

The frequency of the blinks of the LEDs labeled **S** shows the speed of the corresponding ports. This table maps the blink frequency of a LED to the speed of the corresponding port.

Blink Frequency	Speed
No blink	No link
1 blink	10Mbps
2 blinks	100Mbps
3 blinks	1000Mbps

## Bezel Side LED Status

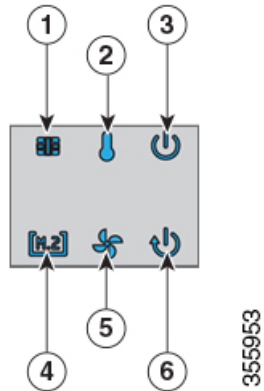

No.	LED Label	Color	Behavior
1	Modem	Blue	Modem up, SIM installed and active.
		Blinking blue	LTE data activity.
		Amber	Modem up, SIM installed but not active.
		Off	Modem not up or modem up with no SIM.
2	SSD	Blue	SSD present.
		Amber	SSD present with failure.
		Off	SSD not present.
3	Temperature	Blue	Temperature in acceptable range.
		Amber	One or more temperature are not in acceptable range.
		Off	Device power off
4	Fan	Blue	Fan speed is correct.
		Amber	Incorrect fan speed, exceeding the tolerance $\pm 500$ RPM.
		Off	FAN is not being monitored.

No.	LED Label	Color	Behavior
5	Power	Blue	power sequence ok
		Blinking amber	Powering up or power fault.
		Off	Device power off
6	AMD	Blue	AMD power up.
		Amber	AMD power down.
		Off	Device power off

**Rear (I/O) Side LED Status**

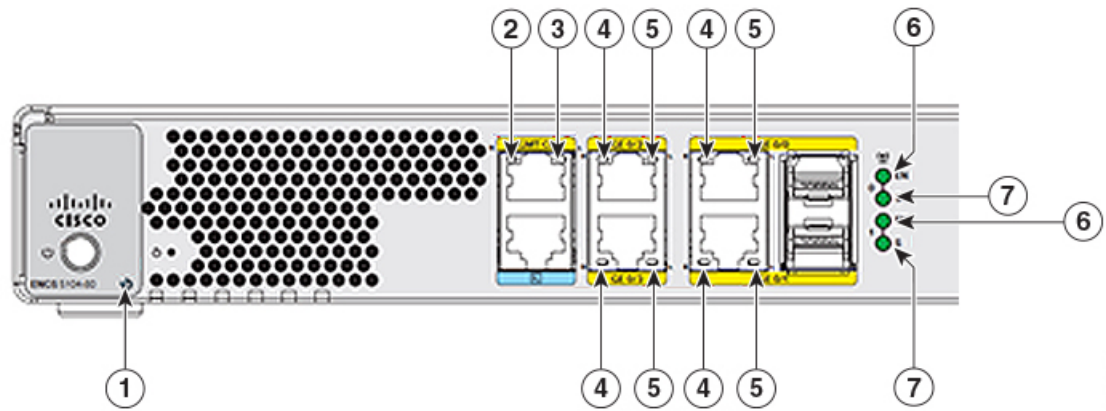

355952

**Table 1: Rear (I/O) Side LED Status**

No.	LED Label	Color	Behavior
1	System Boot LED	Green	AMD power up.
		Amber	AMD power down.
2	AMD Management port Speed LED	Green	Link
		Blinking green	Green Blinking: blink frequency indicates port speed: 1 blink – 10Mbps link speed 2 blinks – 100Mbps link speed 3 blinks – 1000Mbps link speed

No.	LED Label	Color	Behavior
3	AMD Management port Link LED	Green	Ethernet cable present and link established with other side.
4	WAN port GE Speed LED	Blinking green	Green Blinking: blink frequency indicates port speed: 1 blink – 10Mbps link speed 2 blinks – 100Mbps link speed 3 blinks – 1000Mbps link speed
5	WAN port GE Link LED	Green	Ethernet cable present and link established with other side.
6	WAN port SFP Enable LED	Green	Indicates SFP module detected and recognized.
		Amber	Indicates SFP is not recognized or in a fault state.
7	WAN port SFP Speed LED	Blinking green	Blink frequency indicates port speed: 3 blinks – 1000Mbps link speed

## Hardware Features

The following are the units of Cisco 5100 ENCS:

- **M.2 storage module:** This is a high capacity storage component on the motherboard. The OS is installable in this module. The storage capacity of this module is upgradeable. The different storage capacities that are currently available for this module are 64GB, 200GB, and 400GB. Other storage capacities might be made available in the future.
- **DDR4 DIMM Slots:** There are two DDR4 dual in-line memory module (DIMM) slots on the motherboard. Each slot can hold 8 GB or 16 GB memory module. The memory module in each of the slots can be upgraded to a maximum of 16 GB. As a result, you can have a maximum capacity of 32 GB.

# Models

The Cisco 5100 ENCS is available in these models:

Product ID	Description
ENCS5104-64/K9	This device has 64 GB storage capacity.
ENCS5104-200/K9	This device has 200 GB storage capacity.
ENCS5104-400/K9	This device has 400 GB storage capacity.



**Note** With the exception of M.2 drive and memory, other hardware features are common across all models.



**Note** In the Cisco 5100 Enterprise Network Compute System, when the hardware units (for example, BIOS) are implemented separately, the compliance labels for each of them are different leading to label mismatch. To avoid the confusion, you must use the compliance label as the primary for the 74 TAN.

# SFP Modules

This section provides information on Cisco Small Form-Factor Pluggable (SFP) Modules in Cisco ENCS 5100. The switch Gigabit Ethernet SFP and SFP+ modules provide copper or optical connections to other devices. These modules are hot-swappable and provide the uplink interfaces. The SFP modules have fiber-optic LC connectors or RJ-45 copper connectors.

Use only supported SFP modules on the switch. Each module has an internal serial EEPROM that is encoded with security information.



**Note** If non-supported SFP is plugged into the system, you need to reboot the system after removing the non-supported SFP for other SFPs to work normally.



**Warning** Class 1 laser product. Statement 1008



**Caution** Pluggable optical modules comply with IEC 60825-1 Ed. 3 and 21 CFR 1040.10 and 1040.11 with or without exception for conformance with IEC 60825-1 Ed. 3 as described in Laser Notice No. 56, dated May 8, 2019. Statement 1255

**Caution**

Invisible laser radiation may be emitted from the end of the unterminated fiber cable or connector. Do not view directly with optical instruments. Viewing the laser output with certain optical instruments (for example, eye loupes, magnifiers, and microscopes) within a distance of 100 mm may pose an eye hazard. Statement 1056

Fiber type and Core diameter ( $\mu\text{m}$ )	Wavelength (nm)	Max. Power (mW)	Beam divergence (rad)
SM 11	1200 - 1400	39 - 50	0.1 - 0.11
MM 62.5	1200 - 1400	150	0.18 NA
MM 50	1200 - 1400	135	0.17 NA
SM 11	1400 - 1600	112 - 145	0.11 - 0.13

3-49377

The Cisco ENCS 5100 supports the following SFP modules:

Part Number	Description
GLC-LH-SMD	Cisco 1000BASE-LX/LH SFP module for MMF <sup>1</sup> and SMF, 1300-nm wavelength, commercial operating temperature range.
GLC-SX-MMD	Cisco 1000BASE-SX SFP module for MMF, 850-nm wavelength, extended operating temperature range.
SFP-GE-S	Cisco 1000BASE-SX SFP module for MMF, 850-nm wavelength, extended operating temperature range.

<sup>1</sup> A mode-conditioning patch cord, as specified by the IEEE standard, is required. Using an ordinary patch cord with MMF, 1000BASE-LX/LH SFP transceivers, and a short link distance can cause transceiver saturation, resulting in an elevated bit error rate (BER). When using the LX/LH SFP transceiver with 62.5-micron diameter MMF, you must also install a mode-conditioning patch cord between the SFP transceiver and the MMF cable on both the sending and receiving ends of the link. The mode-conditioning patch cord is required for link distances greater than 984 feet (300 m).



## CHAPTER 2

# Preparing for Installation

- [Safety Recommendations and Warnings, on page 9](#)
- [Safety with Electricity, on page 10](#)
- [Site Requirements, on page 11](#)
- [Mounting Requirements, on page 12](#)
- [Power Guidelines and Requirements, on page 13](#)
- [Network Cabling Specification, on page 13](#)
- [Required Tools and Equipment, on page 13](#)

## Safety Recommendations and Warnings

Review the safety warnings listed in Regulatory Compliance and Safety Information for the Cisco 5100 Enterprise Network Compute System before installing, configuring, or maintaining the device.

Please read the following safety guidelines before you install this product:



---

**Warning**

This warning symbol means danger. You are in a situation that could cause bodily injury. Before you work on any equipment, be aware of the hazards involved with electrical circuitry and be familiar with standard practices for preventing accidents. Use the statement number provided at the end of each warning to locate its translation in the translated safety warnings that accompanied this device. Statement 1071

---



---

**Warning**

Read the installation instructions before you connect the system to its power source. Statement 1004

---



---

**Warning**

Ultimate disposal of this product should be handled according to all national laws and regulations. Statement 1040

---



---

**Warning**

Installation of the equipment must comply with local and national electrical codes. Statement 1074

---

Always follow these electrostatic discharge (ESD) prevention procedures when removing and replacing modules:

- Ensure that the chassis is electrically connected to ground.
- Wear an ESD-preventive wrist strap, ensuring that it makes good skin contact. Connect the clip to an unpainted surface of the chassis frame to channel unwanted ESD voltages safely to ground. To guard against ESD damage and shocks, the wrist strap and cord must operate effectively.
- If no wrist strap is available, ground yourself by touching a metal part of the chassis.



---

**Note** For the safety of your equipment, periodically check the resistance value of the anti-static strap. It should be between 1 and 10 megohms (Mohm).

---

## Safety with Electricity

Follow these general guidelines when working on equipment that is powered by electricity:

- Locate the emergency power-off switch in the room in which you are working. If an electrical accident occurs, you can quickly turn off the power.
- Disconnect all power before doing the following:
  - Installing or removing a chassis.
  - Working near power supplies.
- Look carefully for possible hazards in your work area, such as moist floors, ungrounded power extension cables, frayed power cords, and missing safety grounds.
- Do not work alone if hazardous conditions exist.
- Never assume that power is disconnected from a circuit. Always check.
- Never open the enclosure of the internal power supply.
- If an electrical accident occurs, proceed as follows:
  - Turn off power to the device.
  - Call for help.
  - Determine if the person needs rescue breathing or external cardiac compressions; then take appropriate action.

Follow these guidelines when working with any equipment that is disconnected from a power source but is still connected to telephone wiring or other network cabling:

- Never install telephone wiring during a lightning storm.
- Never install telephone jacks in wet locations unless the jack is specifically designed for it.



- Never touch uninsulated telephone wires or terminals unless the telephone line is disconnected at the network interface.
- Use caution when installing or modifying telephone lines.
- Remove power cables from all installed power supplies before opening the chassis.

Always follow these electrostatic discharge (ESD) prevention procedures when removing and replacing modules:

- Ensure that the router chassis is electrically connected to ground.
- Wear an ESD-preventive wrist strap, ensuring that it makes good skin contact. Connect the clip to an unpainted surface of the chassis frame to channel unwanted ESD voltages safely to ground. To guard against ESD damage and shocks, the wrist strap and cord must operate effectively.
- If no wrist strap is available, ground yourself by touching a metal part of the chassis.



---

**Caution**

For the safety of your equipment, periodically check the resistance value of the anti-static strap. It should be between 1 and 10 megohms (Mohm).

---

## Site Requirements

Follow the general precautions listed below when installing or working with your device:

- Do not block cooling vents.
- Route system cables, and the power supply cable and plug so that they cannot be stepped on or tripped over. Be sure that nothing else rests on your system component cables or power cable.
- If you turn off your system, wait at least 30 seconds before turning it on again to avoid system component damage.



---

**Warning**

This product relies on the building's installation for short-circuit (overcurrent) protection. Ensure that the protective device is rated not greater than: 20A Statement 1005

---



---

**Warning**

To prevent the system from overheating, do not operate it in an area that exceeds the maximum recommended ambient temperature of: 40 degrees C. Statement 1047

---

Temperature, humidity, altitude, and vibration can affect the performance and reliability of the chassis. After installation, ensure that the site maintains the environmental characteristics shown in this table:

Environmental Characteristic	Minimum	Maximum
Steady State Operating	0 degree C	40 degree C (40 degrees C at 10,000 feet)
Storage	-20 degrees C	+70 degrees C
Humidity operating (noncondensing)	10%	90%
Humidity nonoperating (noncondensing)	5%	95%
Altitude operating: over allowable temperature range (0 to 40 degrees C)	-500 feet	10,000 feet
Altitude, nonoperating: over allowable temperature range	-1000 feet	50,000 feet
Thermal shock non-operating with change over time of 3 minute	-25 degrees C	+70 degrees C
Thermal Shock - Operating at 2.5 degree C per minute	0 degrees C	+40 degrees C

## Mounting Requirements

The height, width, depth and weight of the chassis are displayed in this table:

Characteristic	Measurement
Height	1.73 inches (4.39 cm) — 1RU rack-mount
Width	12.70 inches (32.258 cm)
Depth	10.0 inches (25.4 cm)
Weight	6.6 lbs. (2.99 kg)

To place the system in a proper location, it is necessary to know the dimensions of the device's chassis.

The Cisco 5100 ENCS can be placed on a desktop or installed in a rack. The mounting ears for the device are designed for #12-24 UNC screws.

The location of your device and the layout of your equipment rack or wiring room are extremely important considerations for proper operation. Equipment placed too close together, inadequate ventilation, and inaccessible panels can cause malfunctions and shutdowns, and can make maintenance difficult. Plan for access to both front and rear panels of the device.

This information can help you plan the rack configuration for your equipment:

- Allow clearance around the rack for maintenance.
- Allow at least one rack unit of vertical space between devices.

- Enclosed racks must have adequate ventilation. Ensure that the rack is not congested, because each device generates heat. An enclosed rack should have louvered sides and a fan to provide cooling air. Heat generated by equipment near the bottom of the rack can be drawn upward into the intake ports of the equipment above it.
- When mounting a chassis in an open rack, ensure that the rack frame does not block the intake or exhaust ports. If the chassis is installed on slides, check the position of the chassis when it is seated in the rack.

## Power Guidelines and Requirements

Check the power at your site to ensure that you are receiving "clean" power (free of spikes and noise). Install a power conditioner if necessary.

The AC power supply supports either 110V or 220V operation. All units include a 6-foot (1.8-meter) electrical power cord.

## Network Cabling Specification

- Ethernet cables for RJ45 ports
- Serial or console cables used to connect devices like routers
- Shielded USB cables with properly terminated shields for the USB port

## Required Tools and Equipment

You will need the following equipment to install the device and its equipment:

- ESD-preventive cord and wrist strap
- Phillips screwdrivers: small, 3/16-in. (4 to 5 mm), and medium, 1/4-in. (6 to 7 mm)
- Screws that fit your rack
- Wire crimper for chassis grounding - to be used along with the ground lug kit
- One 14 AWG cable for the ground lug kit

In addition, depending on the type of modules you plan to use, you might need the following equipment to connect a port to an external network

- Cables for connection to the WAN and LAN ports (dependent on the configuration)



---

**Note** If you order the required cables when you purchase the device, the cables ship along with the product.

---





## CHAPTER 3

# Installing the Device

---

- [Unpacking the Device, on page 15](#)
- [Installing the Cisco 5100 ENCS, on page 15](#)
- [Grounding the Chassis, on page 18](#)
- [Powering On the Server, on page 19](#)
- [Initial Server Setup, on page 19](#)

## Unpacking the Device

The device, accessory kit, publications, and any optional units may be shipped in more than one container. When you unpack the containers, check the packing list to ensure that you have received all the items on the list.

Only unpack the product when you are ready to install it. This will help prevent accidental damage.

## Installing the Cisco 5100 ENCS

If not already installed, the DIMMs and the M.2 storage module must be installed before rack-mounting or wall-mounting the chassis.



---

**Warning**

Only trained and qualified personnel should be allowed to install, replace, or service this equipment. Statement 1030

---

## Rack-Mounting the Chassis

The Cisco 5100 ENCS can be installed in 19-inch (48.26-cm) racks. Use the standard brackets shipped with the chassis for mounting the chassis in a 19-inch EIA rack.



---

**Warning**

To prevent airflow restriction, allow clearance around the ventilation openings to be at least: 1-inch (25.4-mm) Statement 1076

---

You can mount the device in the following ways:

- Front mounting—Brackets attached at the front of the chassis with the front panel facing forward
- Back mounting—Brackets attached at the back of the chassis with the back panel facing forward

### Attaching Brackets to the Chassis

Attach one mounting bracket to each side of the device as shown in following figures. You need two screws to attach each bracket to the device. Total four screws are required to attach both brackets to the device. Use the screws provided with the mounting kit to attach the screws to the device.

**Figure 5: Bracket Installation for Front Mounting**

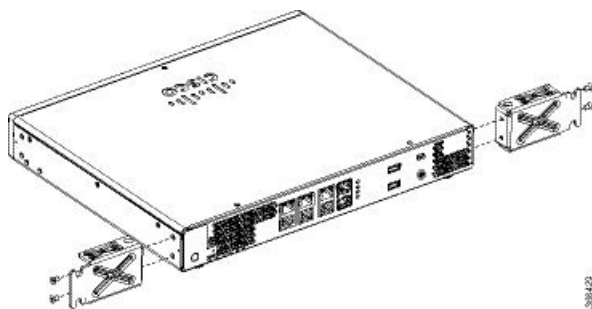

**Figure 6: Bracket Installation for Back Mounting**

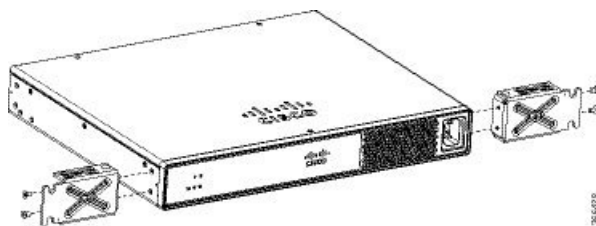

### Mounting the device in a Rack

After you attach the brackets to the device, install the chassis on the rack as shown in following figures. You need two screws to attach each bracket to the rack. Total four screws are required to attach the device to the rack. The screws for attaching the device to the rack are not provided with the kit.

Figure 7: Mounting the Chassis on the Rack - Front and Back

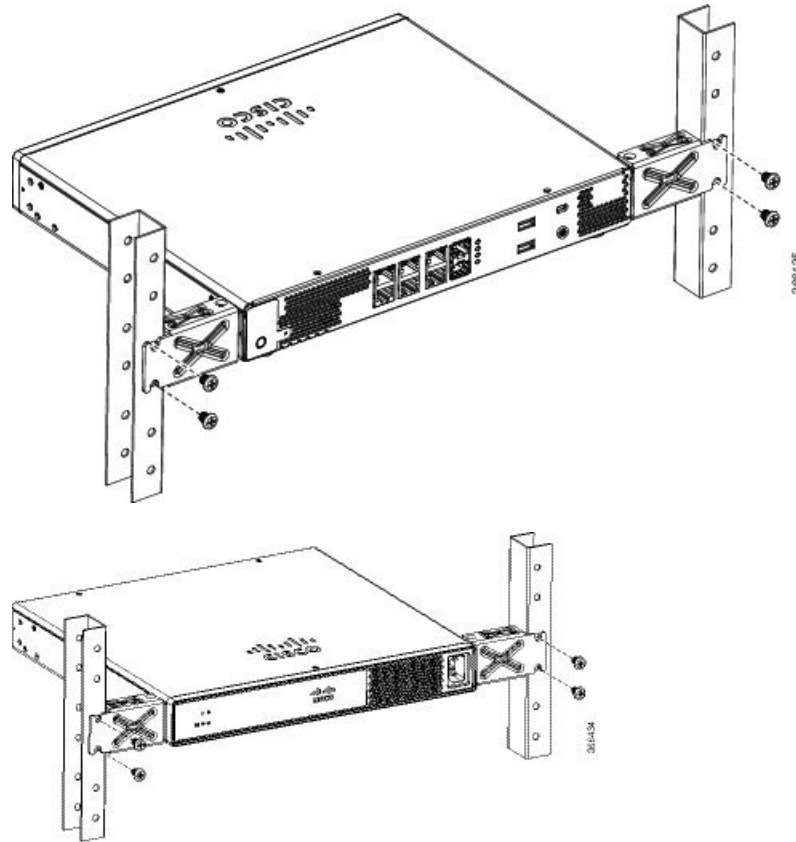

**Tip** The screw slots in the brackets are spaced to line up with every *second* pair of screw holes in the rack. When the correct screw holes are used, the small threaded holes in the brackets line up with unused screw holes in the rack. If the small holes do not line up with the rack holes, you must raise or lower the brackets to the next rack hole.

## Wall-Mounting the Chassis

These are the steps to wall mount the chassis:

- Step 1** Attach the brackets to the device using the screws provided with the mounting kit. Two screws should be used to attach each bracket to the chassis as shown in the following figure.

Figure 8: Wall Mounting the Server

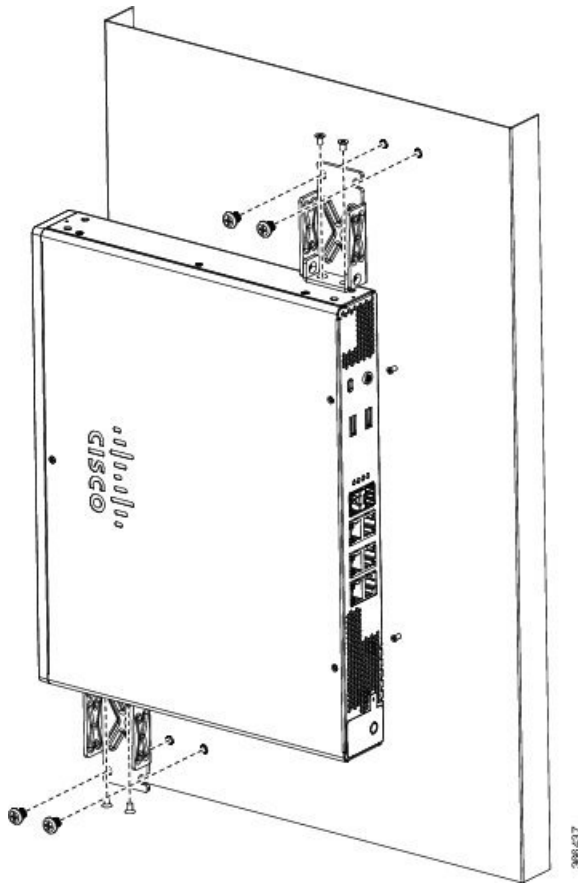

**Step 2** Fix the chassis to the wall using the brackets that you attached to the device.

The screws for attaching the device to the wall are not provided with the kit. Depending on the type of wall (wood, brick, stone etc), use appropriate screws to fix the device to the wall.

**Note** Route the cables so that they do not put a strain on the connectors or mounting hardware. You can only mount chassis with ports going out in left or right direction. Do not mount the chassis with ports facing upward or downward direction.

## Grounding the Chassis



### Warning

This equipment must be grounded. Never defeat the ground conductor or operate the equipment in the absence of a suitably installed ground conductor. Contact the appropriate electrical inspection authority or an electrician if you are uncertain that suitable grounding is available. Statement 1024

These are the steps to install the ground connection for the device:



**Before you begin**

- Connect the chassis to the earth ground; the ground wire must be installed in accordance with local electrical safety standards.
- For grounding, use size 14 AWG copper wire and the ground lug provided in the accessory kit.

- 
- Step 1** Strip one end of the ground wire to the length required for the ground lug.
- Step 2** Crimp the ground wire to the ground lug using a crimp tool of the appropriate size.
- Step 3** Attach the ground lug to the chassis as shown in the figure. Use the screws provided along with the ground lug to attach the lug to the device.

*Figure 9: Chassis Ground Connection on the Device*



## Powering On the Server

- 
- Step 1** Attach the power cord to the power supply unit in the server and then attach the other end of the power cord to the grounded power outlet.
- Step 2** Wait for approximately three minutes.
- Step 3** Verify the power status of the system by looking at the system power status LED. The power status LED blinks in amber color during initial boot up and in solid amber when the system reaches the standby power mode.
- 

## Initial Server Setup

**Local Connection Procedure**

1. Ensure that the device is powered on.
2. Connect serial console port on the front panel of the device.
3. When you see the prompt, you can press F2 to get into the setup (BIOS) to change some settings.
4. After you have performed the required configuration, save the setup and continue to boot.

**Remote Connection Procedure**

1. Plug in your terminal server to the Serial port (Refer to Front panel of Chassis).
2. Telnet into the console and perform the necessary configuration using corresponding commands.





## CHAPTER 4

# Installing and Upgrading Field Replaceable Units

- [Removing and Replacing the Chassis Cover, on page 21](#)
- [Installing a DIMM, on page 22](#)
- [Removing a DIMM, on page 24](#)
- [Upgrading the M.2 Storage Module, on page 25](#)

## Removing and Replacing the Chassis Cover



**Warning** Only trained and qualified personnel should be allowed to install, replace, or service this equipment. Statement 1030

These are the steps to remove the chassis cover:

- Step 1** Confirm that the chassis is turned off and disconnected from the power supply or power supplies.
- Step 2** Place the chassis on a flat surface.
- Step 3** Remove the screws at top of the chassis cover.
- Step 4** Remove the screws at the sides of the device as shown in the following figure.

*Figure 10: Removing the Chassis Cover*

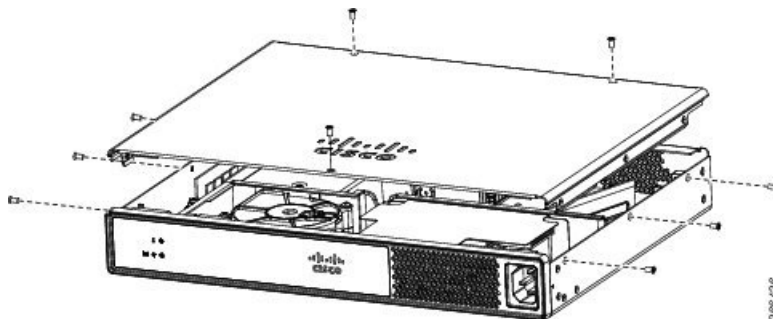

- Step 5** Lift the chassis cover after you have removed all the screws.

**Note** To replace the chassis cover, place the cover evenly on the top of the device and use the screws to secure it to the device.

## Installing a DIMM

There are two DDR4 DIMM slots. DIMMs have a polarization notch on the connecting edge to prevent incorrect insertion.

**Figure 11: DIMM Showing Polarization Notch**

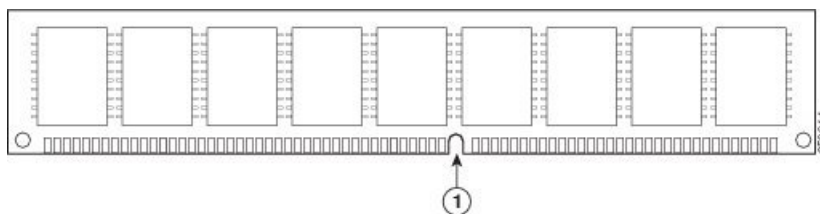

These are the steps to install a DIMM:

- Step 1** Remove the chassis cover.
- Step 2** Locate the DIMM module on the device.

Figure 12: DIMM Module

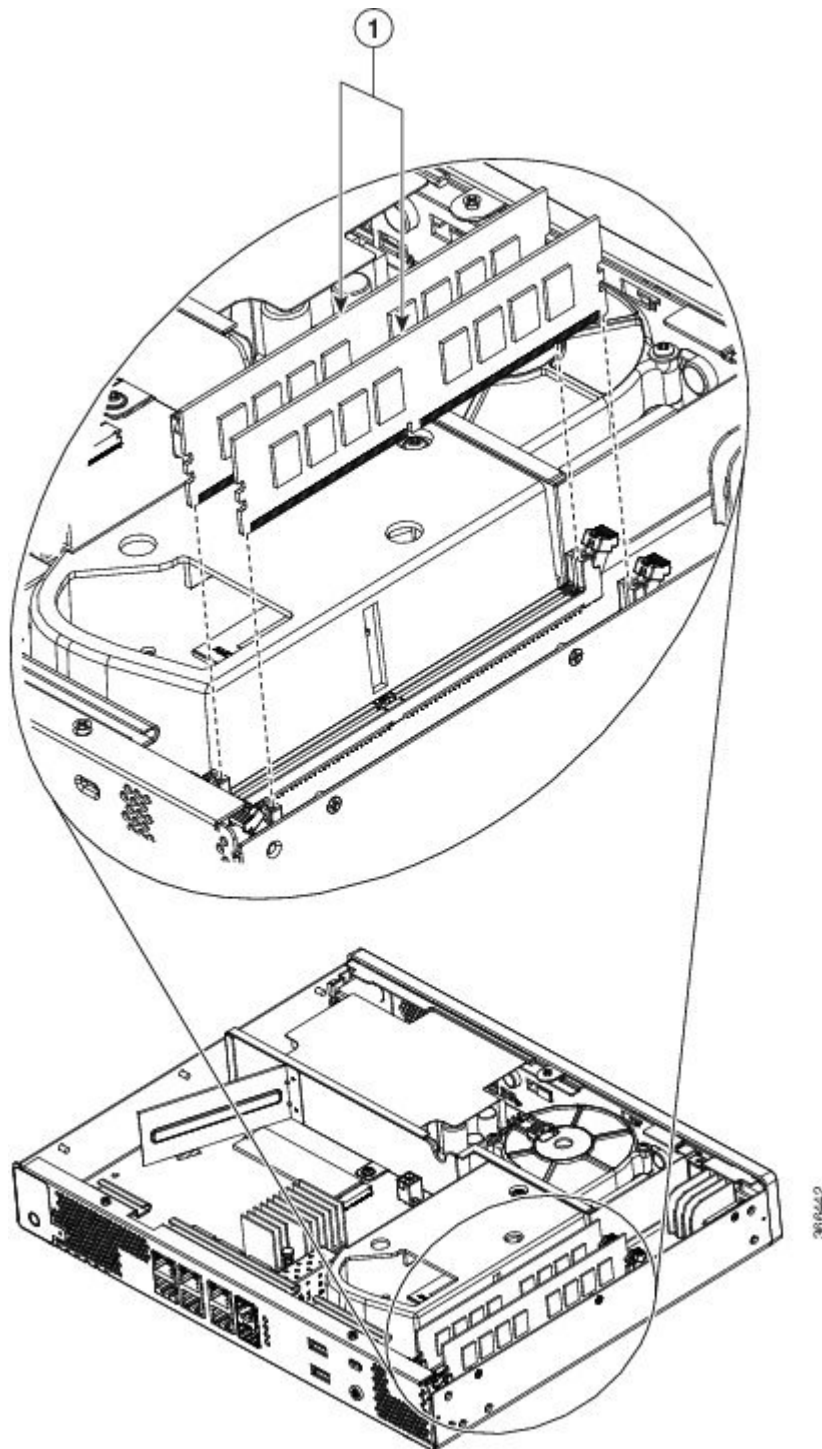

- Step 3** Make sure that both latches on the DIMM connector are in the open position.
- Step 4** Orient the DIMM so that the polarization notch lines up with the polarization key on the connector.
- Step 5** Insert the DIMM into the connector.

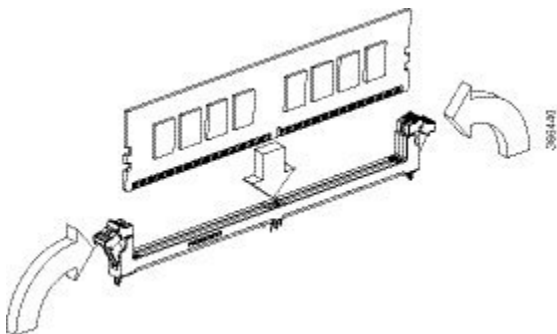
*Figure 13: Inserting a DIMM*

**Step 6** Replace the chassis cover.

## Removing a DIMM

These are the steps to remove a DIMM:

**Step 1** Remove the chassis cover.

**Step 2** Locate the DIMM module on the device. Refer to the [Chassis - Internal, on page 2](#) section to identify and locate the DIMM module.

**Step 3** Pull the latches away from the DIMM at both ends to lift the DIMM slightly. Pull the DIMM out of the socket.

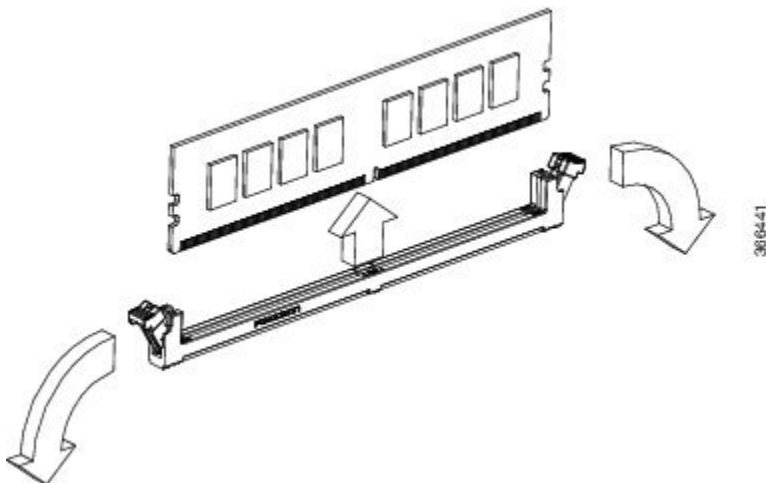
*Figure 14: Removing a DIMM*

**Step 4** Place the DIMM in an antistatic bag to protect it from ESD damage.

**Step 5** Replace the chassis cover.

# Upgrading the M.2 Storage Module

The M.2 storage module is a hardware that is 22mm wide and 80mm long. This hardware comes with different storage capacities.

These are the steps to upgrade the M.2 storage module:

- 
- Step 1** Remove the chassis cover.
  - Step 2** Locate the M.2 storage module. Refer to [Chassis - Internal, on page 2](#) to identify and locate the module.
  - Step 3** Unscrew the screw that secures the old M.2 storage module and then remove the old M.2 storage module.
  - Step 4** Plug in the new M.2 storage module in the same location and secure it with the screw.

*Figure 15: Upgrading the M.2 Storage Module*

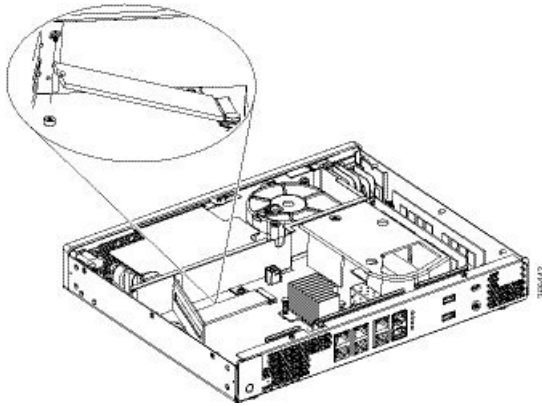

- Step 5** Replace the chassis cover.
-

