



Chassis Overview

This chapter provides an overview of the Cisco NCS 4016 chassis and components.

- [About the Cisco NCS 4016 Chassis, on page 1](#)
- [Chassis Components, on page 4](#)
- [Chassis Cable Management, on page 9](#)
- [Safety Guidelines, on page 9](#)

About the Cisco NCS 4016 Chassis

The Cisco NCS 4016 chassis contains an upper card cage and a lower card cage, each with 11 cards (22 total). The following cards are supported:

- 2 slots for route processor cards (RPs)
- 16 slots for line cards (LCs)
- 4 slots for fabric cards (FCs)

The Cisco NCS 4016 chassis is rack mountable. It is compatible with the following standard rail spacing:

- ANSI 19-inch or 23-inch
- ETSI



Note For the ANSI 19-inch rack, the minimum front opening must be 17.72 inches (450 mm) to allow for chassis insertion. The installation kit includes different brackets for each type of rack.

The Cisco NCS 4016 chassis contains its own power and cooling systems. Power systems are available using AC or DC power. Two fan trays are located in the top and bottom slots of the chassis.



Note The installation of a Cisco NCS 4016 chassis may require space, power, and cooling modifications to a facility. Therefore, you should plan the site well in advance of the scheduled delivery of the chassis system.

This figure shows the front view of the Cisco NCS 4016 chassis.

Figure 1: Front View of the Cisco NCS 4016 Chassis

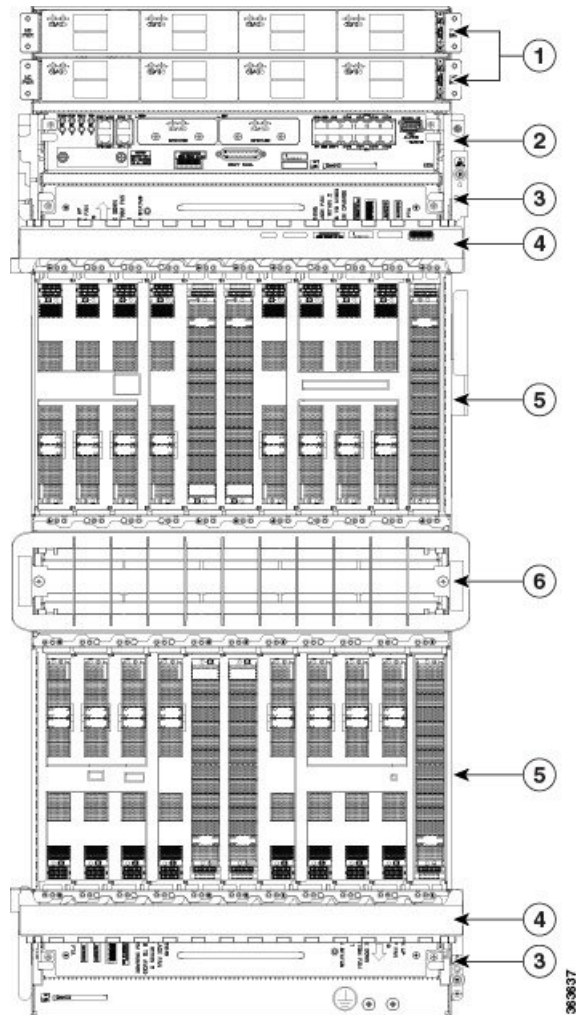

1	Power trays (2)	4	Fiber management areas (2)
2	External connection unit (ECU/ECU2) <ul style="list-style-type: none"> • Craft panel is attached on top of the ECU/ECU2 (not shown, see Figure 2: Partial Chassis View with Craft Panel, on page 3) • Air outlet is on back 	5	Card cages (2) each containing: <ul style="list-style-type: none"> • 8 LC slots • 2 FC slots (in center) • 1 RP slot (at side)
3	Fan trays (2)	6	Air inlet

This figure shows the partial chassis view with craft panel.

Figure 2: Partial Chassis View with Craft Panel

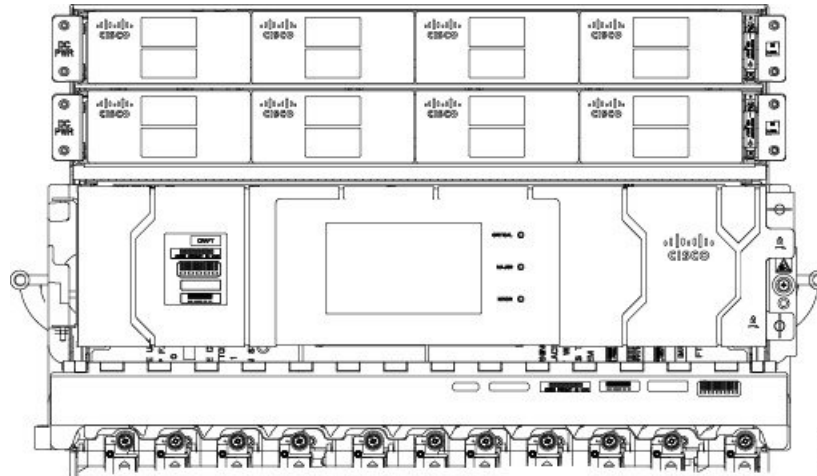

The following figures show partial rear views of the Cisco NCS 4016 chassis.



Note There are two air outlets on the rear of the chassis. One is at the top behind the ECU/ECU2 and one is below the bottom fan tray.

Figure 3: Rear View of the Cisco NCS 4016 AC Chassis

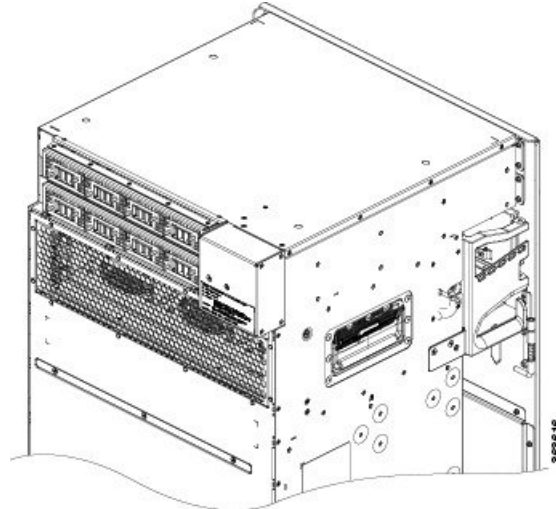

Figure 4: Rear View of the Cisco NCS 4016 DC Chassis

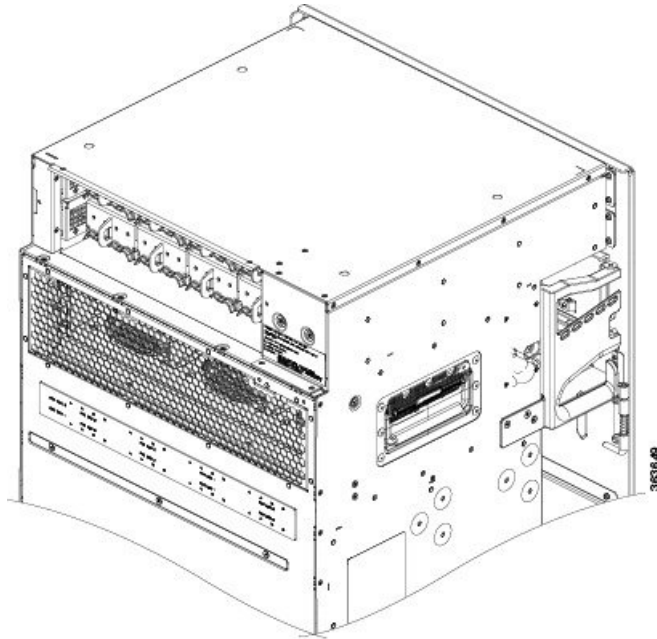
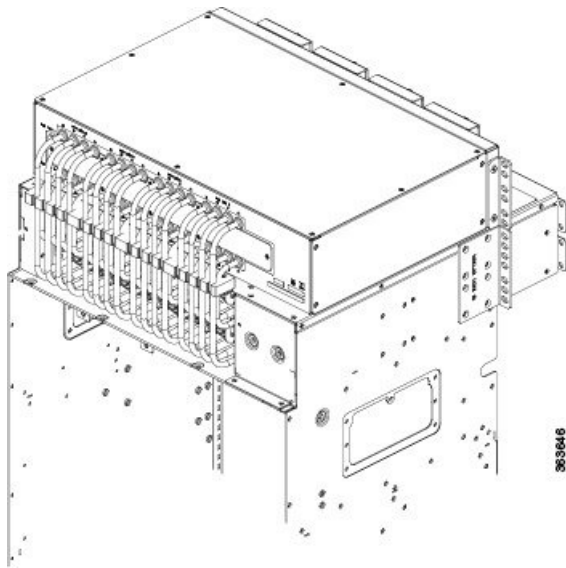

Figure 5: Rear View of the Cisco NCS 4016 DC Chassis with DC Power Front Connection Adapter



Chassis Components

This table lists the main components of the Cisco NCS 4016 chassis.

Table 1: Main Components of the Cisco NCS 4016 Chassis

Component	Description
route processor cards (RPs)	Two RP cards (RP0/RP1) are inserted into the front of the chassis. These cards provide the intelligence of the system by functioning as the system controller and providing route processing and chassis management. The RP cards also monitor system alarms and control the system fans. The LEDs on the front panel indicate active alarm conditions.
fabric cards (FCs)	Four FCs are inserted into the front of the chassis. The FCs provide the switch fabric for the routing system and performs the cross-connect function of the routing system, connecting every LC to each other. The switch fabric receives ingress user data from one LC slot and performs the switching necessary to route the data to the appropriate egress LC slot.
line cards (LCs)	As many as sixteen LCs can be inserted into the front of the chassis. These cards provide the physical interfaces and optical connections for the user data.
external connection unit (ECU/ECU2)	The ECU/ECU2 provides all shelf electrical I/O connectivity to the active and standby route-processor cards. The ECU/ECU2 is located behind the craft panel. ECU2 has four timing expansion (TE) ports on front panel. Two are primary ports and the other two are meant for redundancy and fail over. These TE ports are used for connecting NCS 4000 chassis in the multi chassis configuration.
craft panel	The craft panel can install, configure, monitor, and troubleshoot the Cisco NCS 4016 chassis applications at the node and at the network level. The craft panel is located on top of the ECU/ECU2.
fan trays	Two fan trays are inserted into the front of the chassis at the top and bottom. The top fan tray (behind the craft panel) cools the top card rack and the bottom fan tray covers the bottom card rack. Each fan tray contains six axial fans. The fans pull cooling air through the chassis from the front to rear.
air filter	Two independent air filters are located in the middle of the chassis behind the plastic inlet grill. One is dedicated to the top card rack and the other to the bottom card rack. We recommend that you change the air filter every three months. The filter is sold in packs of 5 (Cisco PID NCS4K-FTF=).
power trays	Two power trays provide redundant power to the chassis. Both AC and DC power trays are available. Each power tray holds up to four AC or DC power modules. A power tray is a field serviceable unit (FSU). A mixture of AC and DC power is not supported in the chassis. Note You must power off the chassis before replacing a power tray.
fiber management trays	Two fiber management trays are located on the front of the chassis. One is above the top card rack and the other is below the bottom card rack.

Chassis Slot Numbers

This section identifies the location and slot numbers for the cards and power modules that plug into the chassis.

Figure 6: Cisco NCS 4016 Chassis Slot Numbers

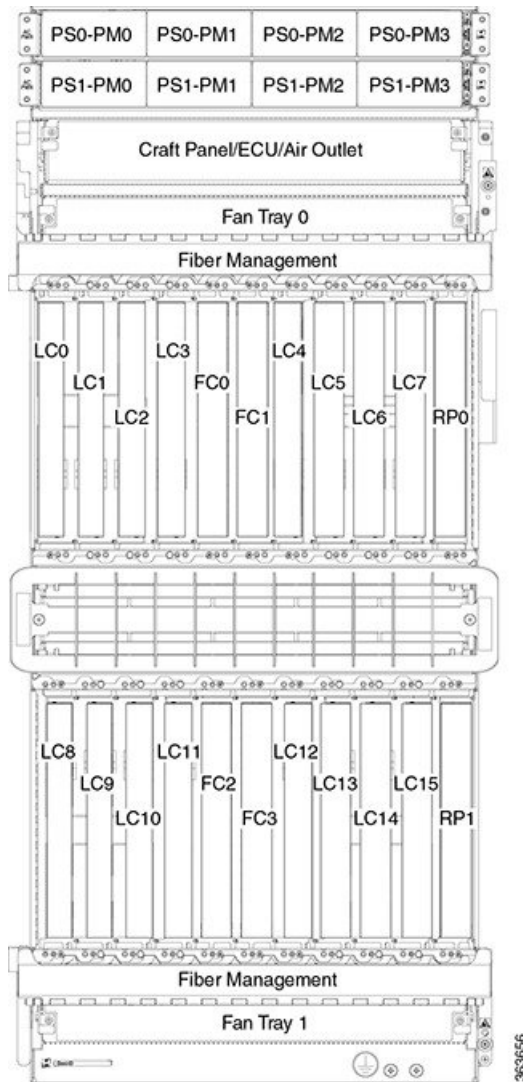

Note Cards in the top and bottom card cages are not inserted in the same direction. If you consider , the above figure, as a reference, cards in the bottom card cage are inserted upside down.

The chassis has the following card slots:

- Sixteen LC slots:
 - Eight in the top card cage (LC0 to LC7)
 - Eight in the bottom card cage (LC8 to LC15)
- Two RP slots:
 - One in the top card cage (RP0)
 - One in the bottom card cage (RP1)

- Four FC slots:
 - Two in the top card cage (FC0, FC1)
 - Two in the bottom card cage (FC2, FC3)
- Two fan trays for redundancy at the top and the bottom of the chassis
- One external connection unit (ECU/ECU2) located above the top fan tray behind the craft panel
- Two fiber management areas at the top and the bottom of the chassis
- One air inlet and two air outlets
- Eight power modules for redundancy
- The upper four AC or DC power trays (0-3) are contained within power shelf 0 (PS0) and the lower four AC or DC power trays (4-7) are contained within power shelf 1 (PS1).

The cards have electrical plugs at the back that plug into electrical connectors on the shelf backplane. When the ejectors are fully closed, the card plugs into the assembly backplane.

The chassis has eight power modules for redundancy:

- The upper four power modules are contained within power tray 0 (PS0). They are named as follows: PS0-PM0, PS0-PM1, PS0-PM2, and PS0-PM3.
- The lower four power modules are contained within power tray 1 (PS1). They are named as follows: PS1-PM0, PS1-PM1, PS1-PM2, and PS1-PM3.

Card Slot Requirements

This figure shows card installation for the Cisco NCS 4016 chassis.

Figure 7: Installing Cards in the Cisco NCS 4016 Chassis

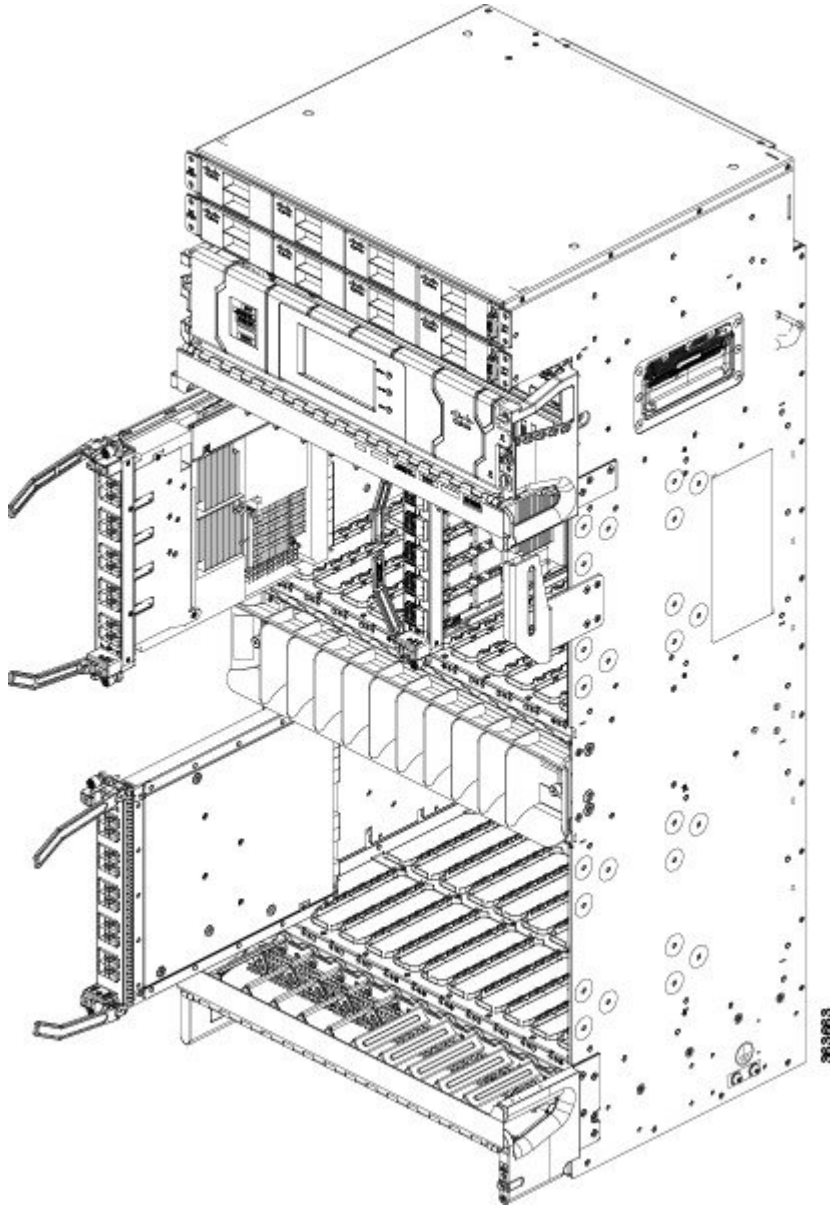

The Cisco NCS 4016 chassis has 22 card slots numbered sequentially from left to right. Slots FC0 through FC3 are dedicated to fabric cards. Slots RP0 and RP1 are reserved for route processor cards.

Shelf assembly slots have symbols indicating the type of cards that you can install in them. Each Cisco NCS 4016 card has a corresponding symbol. The symbol on the card must match the symbol on the slot.

Table 2: Slot and Card Symbols

Symbol Color/Shape	Definition
Orange/Circle	Slots LC0 through LC15. Only install line cards with a circle symbol on the faceplate.

Symbol Color/Shape	Definition
Pink/Triangle	Slots LC0 through LC15. Only install line cards with circle or a triangle symbol on the faceplate.
Blue/Hexagon	Slots LC0 through LC15. Only install line cards with a blue hexagon symbol on the faceplate.
Purple/Square	Slots RP0 and RP1. Only install route processor cards with a square symbol on the faceplate.
Lilac/Cross	Slots FC0 through FC3. Only install fabric cards with a cross symbol on the faceplate.

Chassis Cable Management

The Cisco NCS 4016 chassis has cable management features for the front side only. The horizontal cable management brackets are located above and below the card cages.

Safety Guidelines

Before you perform any Cisco NCS 4009 chassis installation procedures, review the safety guidelines in this section to avoid injuring yourself or damaging the equipment.



Note Review the safety warnings listed in Regulatory Compliance and Safety Information for the Cisco Network Convergence System 4000 Series before installing, configuring, or troubleshooting any installed card.



Note Power off the system before removing or installing a power tray.

The following guidelines are for your safety and to protect equipment. The guidelines do not include all hazards. Be alert.

- Never attempt to lift an object that might be too heavy for you to lift by yourself.
- Keep the work area clear and dust-free during and after installation. Do not allow dirt or debris to enter into any laser-based components.
- Keep tools and chassis components away from walk areas.
- Do not wear loose clothing, jewelry, and other items that could get caught in the chassis while working with the chassis and its components.
- Use Cisco equipment in accordance with its specifications and product-usage instructions.
- Do not work alone if potentially hazardous conditions exist.
- Make sure that your installation follows national and local electrical codes: in the United States, National Fire Protection Association (NFPA) 70, United States National Electrical Code; in Canada, Canadian

Electrical Code, part I, CSA C22.1; in other countries, International Electrotechnical Commission (IEC) 60364, part 1 through part 7.

- Connect only a DC power source that follows the safety extra-low voltage (SELV) requirements in UL/CSA/IEC/EN 60950-1 and AS/NZS 60590 to the DC input power system.
- Make sure that you have a readily accessible two-poled disconnect device incorporated in the fixed configuration wiring of a DC input power system.
- Make sure that you provide short-circuit (overcurrent) protection as part of the building installation.

Safety Labels

Cisco NCS 4000 Series chassis is classified as Hazard Level 1M as per IEC 60825-1, since it includes optical pluggable devices Laser Class 1 or 1M.

The Class 1M Laser Product label is shown in the following figure.

Figure 8: Class 1M Laser Product Label



This section explains the significance of the safety labels attached to the NCS 4016 chassis. You must understand all warning labels before working on the chassis.

Figure 9: Class 1M Laser Product Label



Safety Precaution for Module Installation and Removal

Ensure to observe the following safety precautions when you are working with the chassis modules.



Warning Invisible laser radiation may be emitted from disconnected fibers or connectors. Do not stare into beams or view directly with optical instruments.

Figure 10: Class 1M Laser Product Label



Preventing Electrostatic Discharge

Electrostatic discharge (ESD) damage, which can occur when electronic cards or components are improperly handled, results in complete or intermittent failures. We recommend use of an ESD-preventive wrist strap whenever you handle network equipment or one of its components.

Following are guidelines for preventing ESD damage:

- Always use an ESD-preventive wrist or ankle strap, and ensure that it makes good skin contact. Connect the equipment end of the connection cord to an ESD jack ([Figure 11: ESD Jacks—Top of Chassis, on page 12](#) and [Figure 12: ESD Jacks—Bottom of Chassis, on page 12](#)) or a bare metal surface on the chassis (ensure the chassis is grounded).
- Handle a card by its ejector levers, when applicable, or its metal carrier only; avoid touching the board or connector pins.
- Place a removed card board side up on an antistatic surface or in a static-shielding bag. If you plan to return the component to the factory, immediately place it in a static-shielding bag.
- Avoid contact between a card and clothing. The wrist strap protects the board from only ESD voltage on the body; ESD voltage on clothing can still cause damage.

Figure 11: ESD Jacks—Top of Chassis

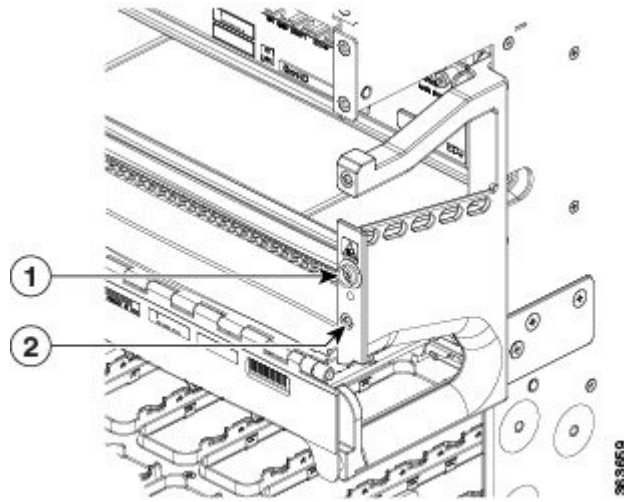

1	Top ETSI connection point	2	Top ANSI jacket point
---	---------------------------	---	-----------------------

Figure 12: ESD Jacks—Bottom of Chassis

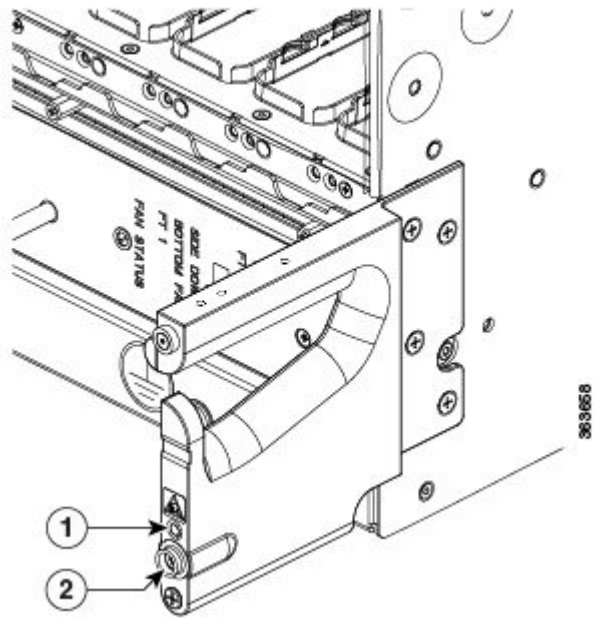

1	Bottom ANSI jacket point	2	Bottom ETSI connection point
---	--------------------------	---	------------------------------

Network Equipment-Building System (NEBS) Statements

NEBS describes the environment of a typical United States Regional Bell Operating Company (RBOC) central office. NEBS is the most common set of safety, spatial, and environmental design standards applied to telecommunications equipment in the United States. It is not a legal or regulatory requirement, but rather an industry requirement.

The following NEBS statements apply to the Cisco NCS 4016:



Note This equipment may be ESD sensitive. Always use an ESD ankle or wrist strap before handling equipment. Connect the equipment end of the ESD strap to an unfinished surface of the equipment chassis or to the ESD jack on the equipment if provided.



Warning **Statement 7003**—Shielded Cable Shielded Cable Requirements for Intrabuilding Lightning Surge

The intrabuilding port(s) of the equipment or subassembly must use shielded intrabuilding cabling/wiring that is grounded at both ends.

The following port(s) are considered intrabuilding ports on this equipment:
ETH0, ETH1, ETH2, 1588, EMS, CRAFT



Warning **Statement 7005**—Intrabuilding Lightning Surge and AC Power Fault

The intrabuilding port(s) of the equipment or subassembly must not be metallically connected to interfaces that connect to the outside plant (OSP) or its wiring. These interfaces are designed for use as intrabuilding interfaces only (Type 2 or Type 4 ports as described in GR-1089-CORE) and require isolation from the exposed OSP cabling. The addition of primary protectors is not sufficient protection to connect these interfaces metallically to OSP wiring.

This statement applies to the intrabuilding ports listed below:
ETH0, ETH1, ETH2, 1588, EMS, CRAFT



Note **Statement 7012**—Equipment Interfacing with AC Power Ports

Connect this equipment to AC mains that are provided with a surge protective device (SPD) at the service equipment that complies with NFPA 70, the National Electrical Code (NEC).



Note This equipment is suitable for installations using the CBN.



Note When you use thread-forming screws to bond equipment to its mounting metalwork, remove any paint and nonconductive coatings and clean the joining surfaces. Apply an antioxidant compound before joining the surfaces between the equipment and mounting metalwork.



Note **Statement 7016**—Battery Return Conductor

The battery return conductor of this equipment shall be treated as (DC-I).



Note This equipment is designed to boot up in less than 30 minutes, depending on its neighboring devices be fully up and running.



Note This equipment is suitable for installation in network telecommunications facilities.



Note This equipment is suitable for installation in locations where the NEC applies.
