



Removing and Replacing Chassis Components

This chapter provides instructions on how to remove and replace components from the Cisco NCS 4009 chassis.

- [Removing a Line Card, on page 1](#)
- [Replacing or Reinserting a Line Card, on page 3](#)
- [Removing an RP Card, on page 4](#)
- [Removing a Fabric Card, on page 6](#)
- [Removing an Auxiliary Fan Tray , on page 9](#)
- [Removing the Power Components, on page 10](#)
- [Removing the Air Filter, on page 16](#)
- [Replacing the Air Filter, on page 19](#)
- [Replacing the Front Door, on page 20](#)
- [Removing the Fan Tray, on page 26](#)
- [Replacing the Fan Tray, on page 27](#)
- [Removing and Replacing the Craft Panel, on page 29](#)
- [Replacing the Craft Panel, on page 31](#)
- [Routing the BITS Cables, on page 31](#)
- [Removing the External Connection Unit, on page 32](#)
- [Replacing the External Connection Unit, on page 33](#)

Removing a Line Card

This section describes how to remove a line card from the Cisco NCS 4009 chassis.



Warning **Class 1 Laser Product.** Statement 113



Warning **Because invisible radiation may be emitted from the aperture of the port when no fiber cable is connected, avoid exposure to radiation and do not stare into open apertures.** Statement 125



Warning For diverging beams, viewing the laser output with certain optical instruments within a distance of 100 mm may pose an eye hazard. For collimated beams, viewing the laser output with certain optical instruments designed for use at a distance may pose an eye hazard. Statement 282

Prerequisites

Before performing this task, open the front door, if installed.



Caution The system can indicate a hardware failure if you do not follow proper procedures. Remove or install only one LC at a time. Allow at least 30 seconds for the system to complete its tasks before removing or installing another LC.

This procedure is traffic-impacting.

Required Tools and Equipment

- ESD-preventive wrist strap
- Number-2 Phillips screwdriver or number-2 common (flat-head) screwdriver

Steps

The following steps describe how to remove a line card.

Figure 1: Removing a Line Card

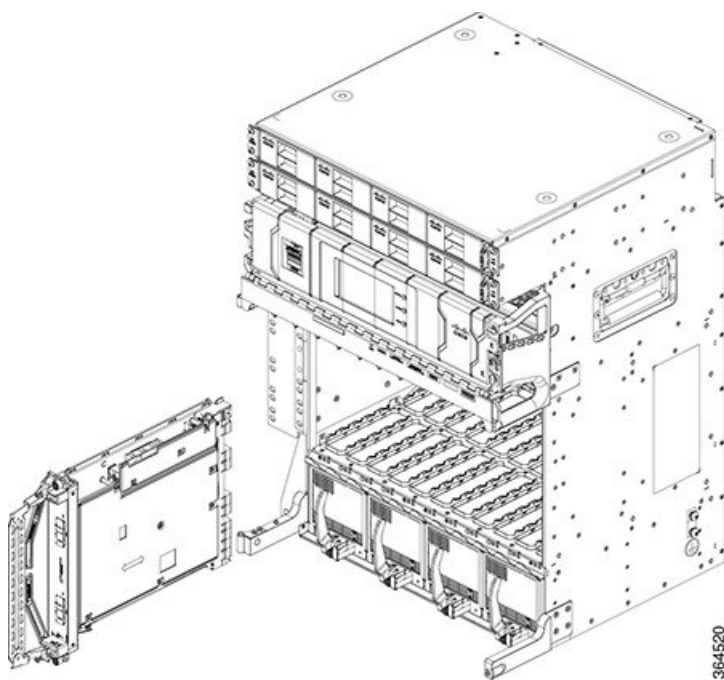

Procedure

-
- Step 1** Attach the ESD-preventive wrist strap to your wrist and connect its leash to the ESD jack located on the front or rear side of the chassis. You can also connect the ESD-preventive wrist strap leash to any bare metal surface on the chassis.
- Step 2** Identify the card to be removed.
- Note** To verify which card needs attention, the Attention LED can be lit using the hw-module attention-led location CLI command.
- Step 3** In the **Node View** of CTC, click the **Inventory** tab and set the **Admin State** of the line card to **OOS** (Out Of Service).
This will shut down the Line Card.
- Step 4** Press the OIR buttons to unlock the ejector levers, wait for 30 seconds.
- Step 5** Use the number-2 Phillips screwdriver or number-2 common (flat-head) screwdriver to loosen the two captive screws holding the card in place.
- Caution** When adjusting the ejector levers, avoid hitting the top and bottom fiber management features and doors.
- Step 6** Grasp the two card ejector levers and simultaneously pivot both ejector levers 70 degrees away from the front edge of the card carrier to unseat the card from the backplane connector.
- Step 7** Touching only the metal card carrier, slide the card from the slot and place it directly into an antistatic sack or other ESD-preventive container.
- Warning** **Because invisible laser radiation may be emitted from the aperture of the port when no cable is connected, avoid exposure to laser radiation and do not stare into open apertures.** Statement 70
-

Replacing or Reinserting a Line Card

This section describes how to replace or reinsert a line card on the Cisco NCS 4009 chassis.



Warning **Class 1 Laser Product.** Statement 113



Warning **Because invisible radiation may be emitted from the aperture of the port when no fiber cable is connected, avoid exposure to radiation and do not stare into open apertures.** Statement 125



Warning For diverging beams, viewing the laser output with certain optical instruments within a distance of 100 mm may pose an eye hazard. For collimated beams, viewing the laser output with certain optical instruments designed for use at a distance may pose an eye hazard. Statement 282

Prerequisites

Before performing this task, open the front door, if installed.



Caution Remove or install only one LC at a time. Allow at least 30 seconds for the chassis to complete its tasks before removing or installing another LC. The chassis may indicate a hardware failure if you do not follow proper procedures.

This procedure is traffic-impacting.

Required Tools and Equipment

- ESD-preventive wrist strap
- Number-2 Phillips screwdriver or number-2 common (flat-head) screwdriver
- LC

Steps

To replace/reinstall the line card:

Procedure

-
- Step 1** Perform the procedure [Removing a Line Card, on page 1](#) to remove the line card that needs to be replaced/reinserted.
- Step 2** Perform the procedure [Installing a Line Card](#) to install a new card or reinsert the same card that was removed in step1.
- Step 3** In the **Node View** of CTC, click the **Inventory** tab.
- Step 4** if **Admin State** of the line card is **OOS** (Out of Service) in CTC, then set the **Admin State** of the line card to **IS** (In Service).

Traffic will resume after the card is in service.

Removing an RP Card

This section describes how to remove a route processor card from the Cisco NCS 4009 chassis.

Prerequisites

Before performing this task, open the front door, if installed. The RP cards are hot-swappable.

Perform this task when you are certain that the other RP card in the chassis is operational and, if not already the active RP, is ready to assume control (this happens automatically). Failure to follow these guidelines can result in interruptions in data communications and network connectivity.



Warning Class 1 Laser Product. Statement 113



Warning Because invisible radiation may be emitted from the aperture of the port when no fiber cable is connected, avoid exposure to radiation and do not stare into open apertures. Statement 125

Required Tools and Equipment

- ESD-preventive wrist strap
- Number-2 Phillips screwdriver or number-2 common (flat-head) screwdriver

Steps

Figure 2: Removing an RP Card

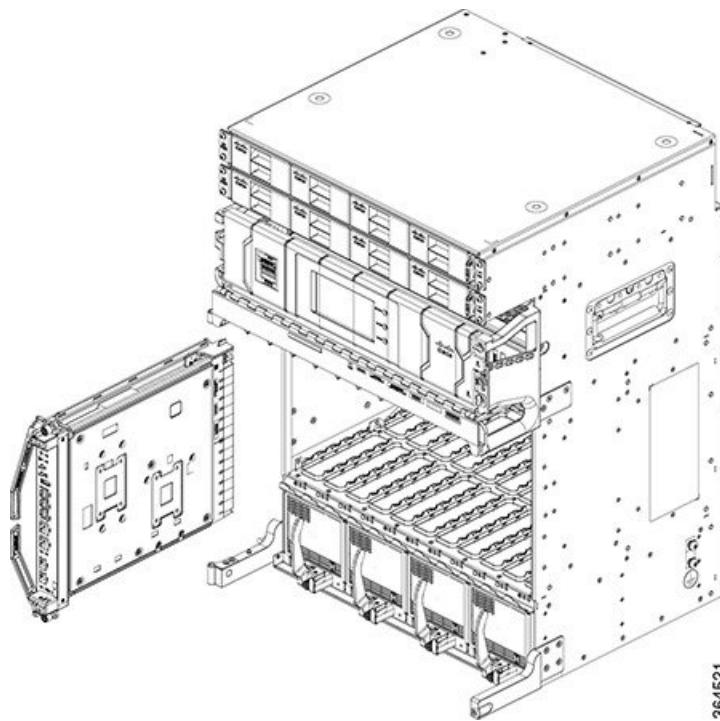

1	Direction and location of removal	3	Captive screw (also one on top)
2	Ejector levers	4	OIR buttons

Procedure

Step 1 Attach the ESD-preventive wrist strap to your wrist and connect its leash to one of the two ESD jacks located on the front or rear side of the chassis. You can also connect the ESD-preventive wrist strap leash to any bare metal surface on the chassis.

Step 2 Identify the card to be removed from the card cage. Reload the RP card to move the active processes to other RPs using the **hw-module location <slot-number> reload** command.

```
sysadmin-vm:0_RP0# hw-module location 0/RP0 reload
```

Note When the RP is up or booting, you can remove the RP card using the OIR button. Pressing the OIR button to unlock the ejector lever when the RP is Active may impact the traffic.

Step 3 Remove any cables connected to the front panel of the card.

Step 4 Press the OIR buttons to unlock the ejectors. Wait for 30 seconds.

Step 5 Use the number-2 Phillips screwdriver or number-2 common (flat-head) screwdriver to turn the two captive screws on the front panel of the card counterclockwise to loosen the card from the slot.

Caution To prevent ESD damage, handle an RP card by its ejector levers or the LC carrier edges only. Do not touch any of the electrical components, pins, or circuitry.

Step 6 Simultaneously pivot the ejector levers away from the faceplate to release the RP card from the backplane connectors.

Step 7 Grasp the two card ejector levers and simultaneously pivot both ejector levers 90 degrees away from the front edge of the card carrier to unseat the card from the backplane connector.

Step 8 Grasp the ejector levers with both hands and gently pull the RP card halfway from the slot.

Step 9 Move one hand under the RP card to guide it. Avoid touching the RP card printed circuit board, components, or any connector pins.

Step 10 Touching only the metal card carrier, slide the card from the slot and place it directly into an antistatic sack or other ESD-preventive container. If you plan to return a defective card to the factory, repackage it in the shipping container that you received with the replacement card.

For replacement, wait for 30 seconds after removing the card from the chassis and then reinsert the new card. For the installation procedure, see [Installing an RP Card](#).

Removing a Fabric Card

This section describes how to remove a fabric card from the Cisco NCS 4009 chassis.

Prerequisites

- Open the front door.
- Remove the air filter. See [Removing the Air Filter, on page 16](#)
- Identify the fabric card to be removed and shut down the plane using the command, **controller fabric plane X shutdown**. X denotes the fabric plane and can be in the range 0 to 3.

```
sysadmin-vm:0_RP0(config)# controller fabric plane 0 shutdown  
sysadmin-vm:0_RP0(config)# commit
```

- For the NCS4009-FC2F-S fabric card, remove the AFT. See [Removing an Auxiliary Fan Tray](#), on page 9

Required Tools and Equipment

- ESD-preventive wrist strap
- Number-2 Phillips screwdriver or number-2 common (flat-head) screwdriver

Figure 3: Removing a Fabric Card - NCS4009-FC2-S

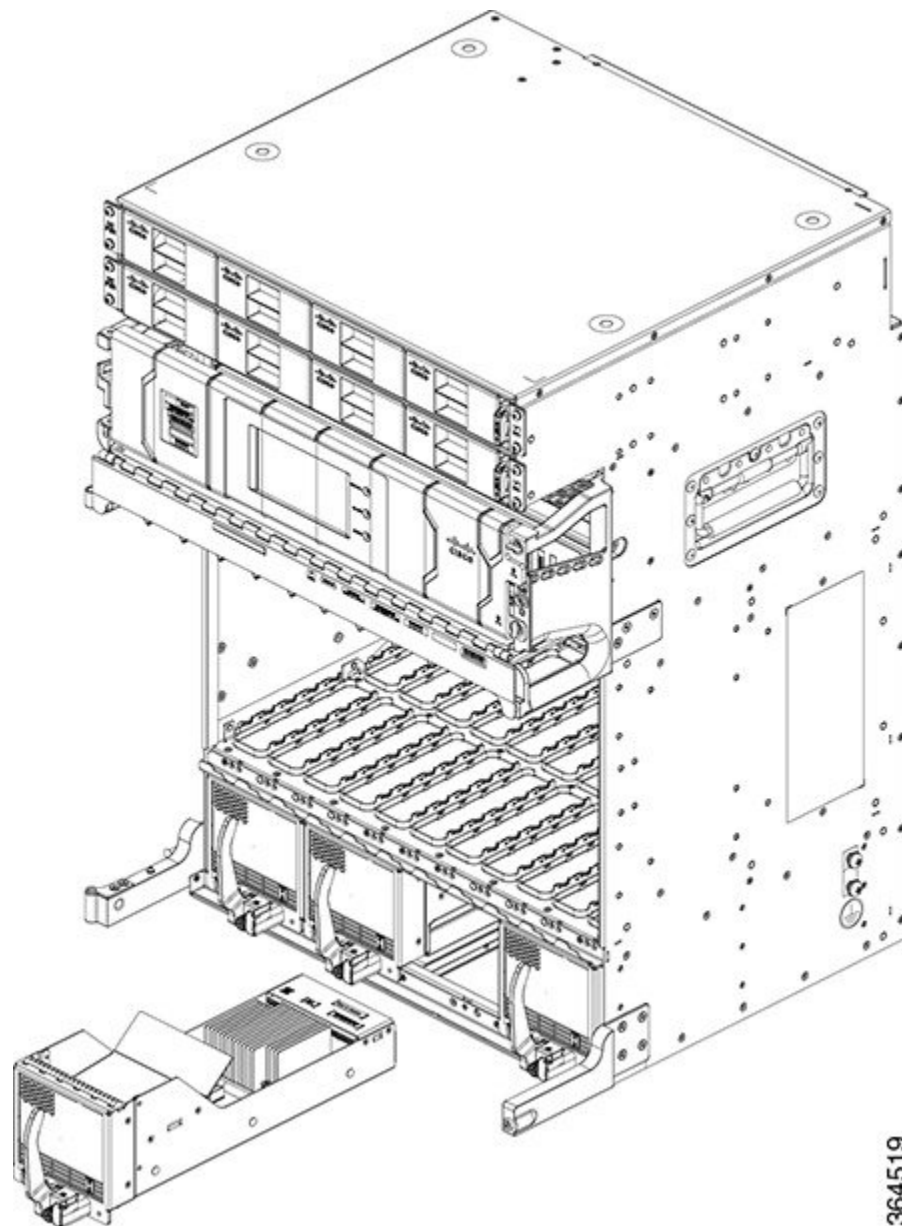
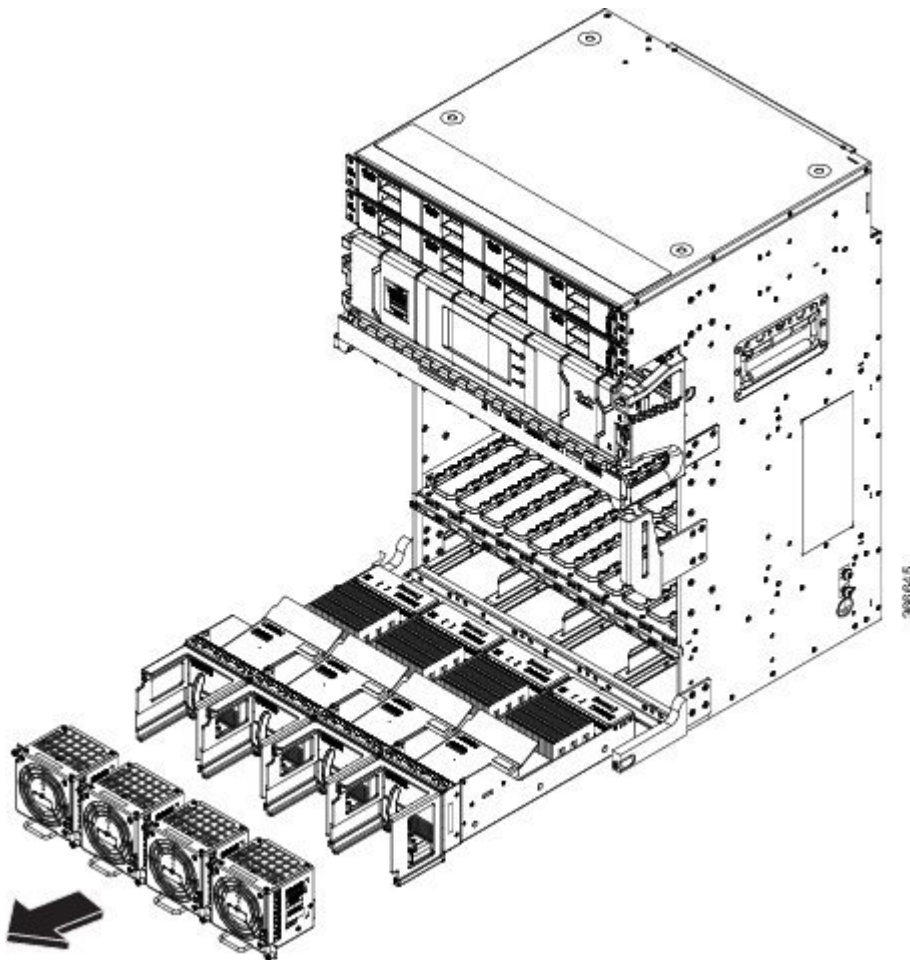

Figure 4: Removing a Fabric Card - NCS4009-FC2F-S



Steps

The following steps describe how to remove a fabric card.

See [here](#) for a graphical representation of the removal of the NCS4009-FC2F-S fabric card and the AFT.

Procedure

-
- Step 1** Attach the ESD-preventive wrist strap to your wrist and connect its leash to the ESD jack located on the front side of the chassis. You can also connect the ESD-preventive wrist strap leash to any bare-metal surface on the chassis.
 - Step 2** Use the number-2 Phillips screwdriver or number-2 common (flat-head) screwdriver to turn the captive screw on the front panel of the card counterclockwise to loosen it from the slot.
 - Step 3** Press the OIR button to unlock the ejector. Wait for 30 seconds.
 - Step 4** Grasp the card ejector lever and pivot the ejector lever 70 degrees away from the front edge of the card carrier to disengage the card from the backplane connector.

Step 5 Touching only the metal card carrier, slide the card from the slot and place it directly into an antistatic bag or other ESD-preventive container. If you plan to return the defective card to the factory, repackage it in its original shipping container.

For replacement, wait for 30 seconds after removing the card from the chassis and then reinsert the new card. For the installation procedure, see [Installing a Fabric Card](#).

Removing an Auxiliary Fan Tray

This section describes how to remove the AFT (Cisco PID NCS4009-FAN-FC).



Warning The maximum time limit for OIR of the AFT is five minutes.

Prerequisites

Before performing this task, remove the air filter.

Required Tools and Equipment

- ESD wrist-strap
- 6-inch, Philips number-2 screwdriver

Steps

The following steps describe how to remove an auxiliary fan tray.

Procedure

Step 1 Loosen the two captive screws on the AFT.

Step 2 Pull the sliding handle out (which is at the base of the AFT).

Step 3 Gently pull the AFT out of the fabric card frame, using the sliding handle.

Warning **The fans might still be turning when you remove the fan assembly from the chassis. Keep fingers, screwdrivers, and other objects away from the openings in the fan assembly's housing.** Statement 263



Note During the removal and replacement of an AFT, the other three AFTs and the primary fan tray run at maximum speed. The AFTs return to the normal speed in one minute, the PFT returns to the normal speed in five minutes.

What to do next

For the replacement procedure of the AFT, follow steps 9 to 11 of [Installing a Fabric Card](#)

Removing the Power Components

This section describes how to remove power components from the Cisco NCS 4009 chassis.



Note Although there are differences between AC and DC power trays and power modules, they are removed using the same procedures.

While it is possible to remove power components from the Cisco NCS 4009 chassis separately, some parts (such as the power tray) require that other parts be removed first.

We recommend that you remove the power components in the order outlined in this section.

Removing AC Input Power Cords

This section describes how to remove AC input power cords from a power tray.

Prerequisites

Power off the AC power modules in the tray you want to disconnect.



Note Before removal, make sure that the input power cables are not energized.

Required Tools and Equipment

- ESD-preventive wrist strap
- 6-inch, number-1 Phillips screwdriver

Steps

To remove the AC input power cords, go to the rear of the chassis and perform the following steps:

Procedure

-
- Step 1** Attach the ESD-preventive wrist strap to your wrist and connect its leash to one of the two ESD jacks on the rear of the chassis. You can also connect the ESD-preventive wrist strap leash to any bare metal surface on the chassis.
- Step 2** Verify that the AC input source breaker is in the off position.
- Step 3** Use the screwdriver to loosen the screws that clamp the cords in place.
- Step 4** Remove the cords from the cord clamps.
-

Removing DC Input Power Cables

This section describes how to remove DC input power cables from a power tray terminal block.

Prerequisites

Power off the DC power modules in the tray you want to disconnect.



Note Before removal, make sure that the input power cables are not energized.

Required Tools and Equipment

- ESD-preventive wrist strap
- 6-inch, number-1 Phillips screwdriver
- 3/8-inch ratchet wrench with 7/16-pt. socket
- Voltmeter

Steps

To disconnect DC input power cables, go to the rear of the chassis or the front if the DC rear to front converter box is used and perform the following steps:

Procedure

-
- Step 1** Attach the ESD-preventive wrist strap to your wrist and connect its leash to one of the two ESD jacks on the rear of the chassis. You can also connect the ESD-preventive wrist strap leash to any bare metal surface on the chassis.
- Step 2** Using the voltmeter, verify that there is no voltage on the cables that are about to be removed.
- Step 3** Use the screwdriver to remove the screw that secures the terminal block cover into the mounting standoff.
- Step 4** Slide the terminal block cover downward.
- Step 5** Remove the terminal block cover.
- Step 6** Disconnect the DC power cables from their terminals in the following order and note the color of each cable:
- a) Negative (PWR) cables first.
 - b) Positive (RTN) cables last.
- Step 7** Replace the terminal block cover.
-

Removing the Chassis Ground Cable

This section describes how to remove the chassis ground cable on the Cisco NCS 4009 chassis.

Prerequisites

Before performing this task, completely power off the entire system. Remove all AC or DC input power connections.



Caution Do not remove the chassis ground cable unless the chassis is powered off and to be replaced.

Required Tools and Equipment

- 3/8-inch drive socket wrench
- 10-mm 6-pt. socket

Steps

Procedure

To remove the ground cable from the chassis, remove the two M6 bolts that attach the ground cable to the NEBS grounding point.

Removing a Power Module Slot Cover

This section describes how to remove a power module slot cover from a power module slot in an AC or DC power tray.

Steps

To remove a power module slot cover from the front of a power tray, perform the following steps:

Procedure

-
- Step 1** Gently pinch the tabs on the top of the power module slot cover to partially detach the slot cover from the slot.
- Step 2** Slide the power module slot cover out by removing the tabs on the bottom of the power module slot cover from the two holes on the bottom of the slot.
-

Removing an AC or DC Power Tray

This section describes how to remove a power tray from the Cisco NCS 4009 chassis.

Prerequisites

- Power off the power shelf that houses the power tray you are about to remove.
- Ensure the power tray you are about to remove is empty. It is not necessary to turn off the switch on the power tray to remove individual power modules. Power modules support OIR, so they can be removed and replaced with the power on and the system operating.

**Caution**

The I/O switch on each power shelf disables the output of the power modules in that shelf only. The inputs to the power modules remain hot, as well as the system's internal bus bar (due to the other power shelf).

**Warning**

In case of power tray replacement, first remove the rear power connections before extracting the power tray. In DC, if the power connections are not removed, the connected power cables will prevent the power tray from being extracted. The power lugs could also be shorted with the metal part of the chassis causing physical damage to the equipment or personnel.

Required Tools and Equipment

- 6-inch, number-1 Phillips screwdriver

Steps

To remove an AC or DC power tray, perform the following steps:

Procedure

-
- Step 1** Use the screwdriver to loosen the two screws that attach each power tray to the chassis.

Figure 5: Removing a Power Tray from the Chassis

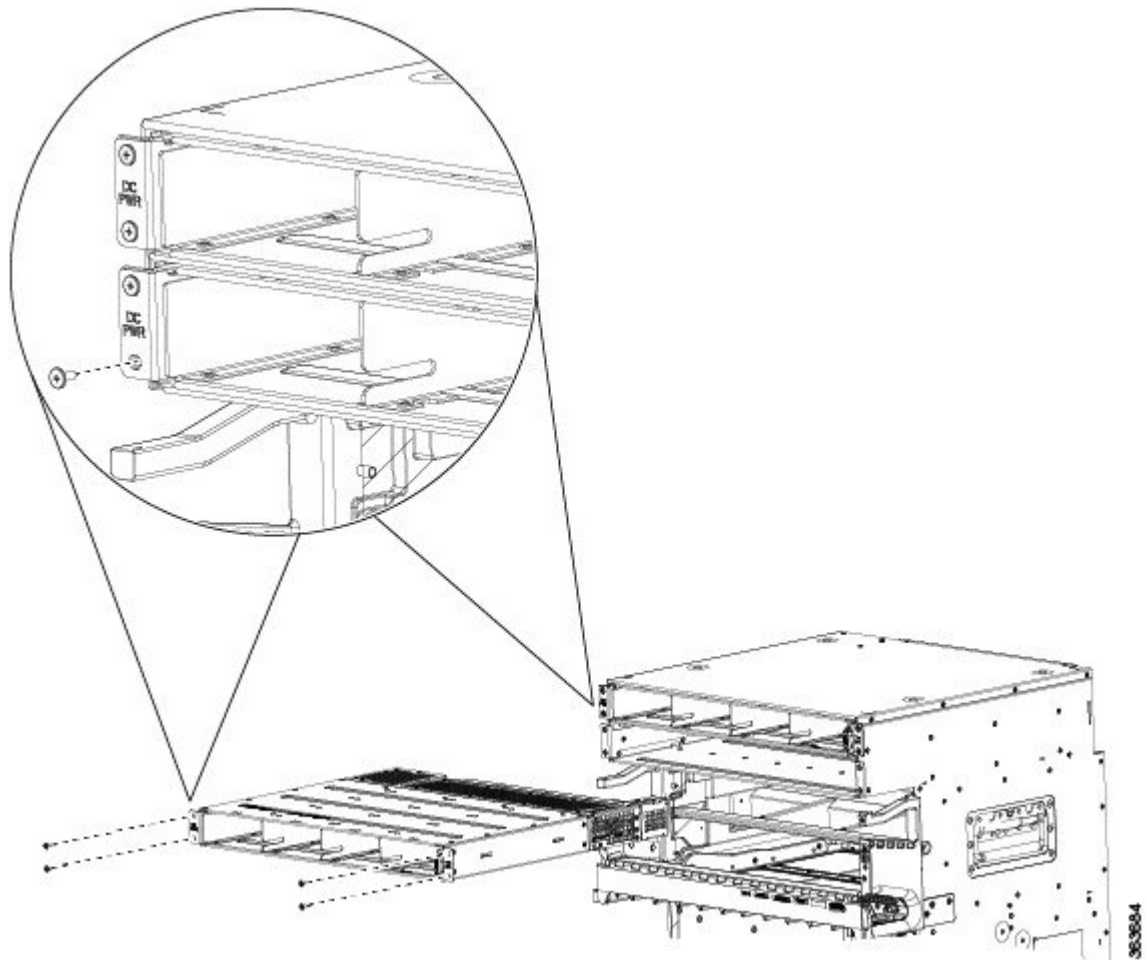

Step 2 Slide the power tray all the way out of the chassis, fully supporting it during removal. You can use the vertical slot dividers to grip the unit.

Caution Because of the weight of the power tray, and the height at which the power tray is installed in the chassis, you should be especially careful while removing and carrying the power tray. To prevent injury, avoid sudden twists or lateral moves.

Removing an AC or DC Power Module

This section describes how to remove a power module from a power tray.



Note It is not necessary to turn off the switch on the power tray to remove individual power modules. Power modules support OIR, so they can be removed and replaced with the power on and the system operating.

Steps

To remove a power module from the front of a power tray, perform the following steps:

Procedure

- Step 1** Release the snap hook on the power module.
- Step 2** Slide the power module out of its bay in the power tray while supporting it with your other hand. Use the handle available on the front plate of the power module.

Figure 6: Removing a Power Module from a Power Tray

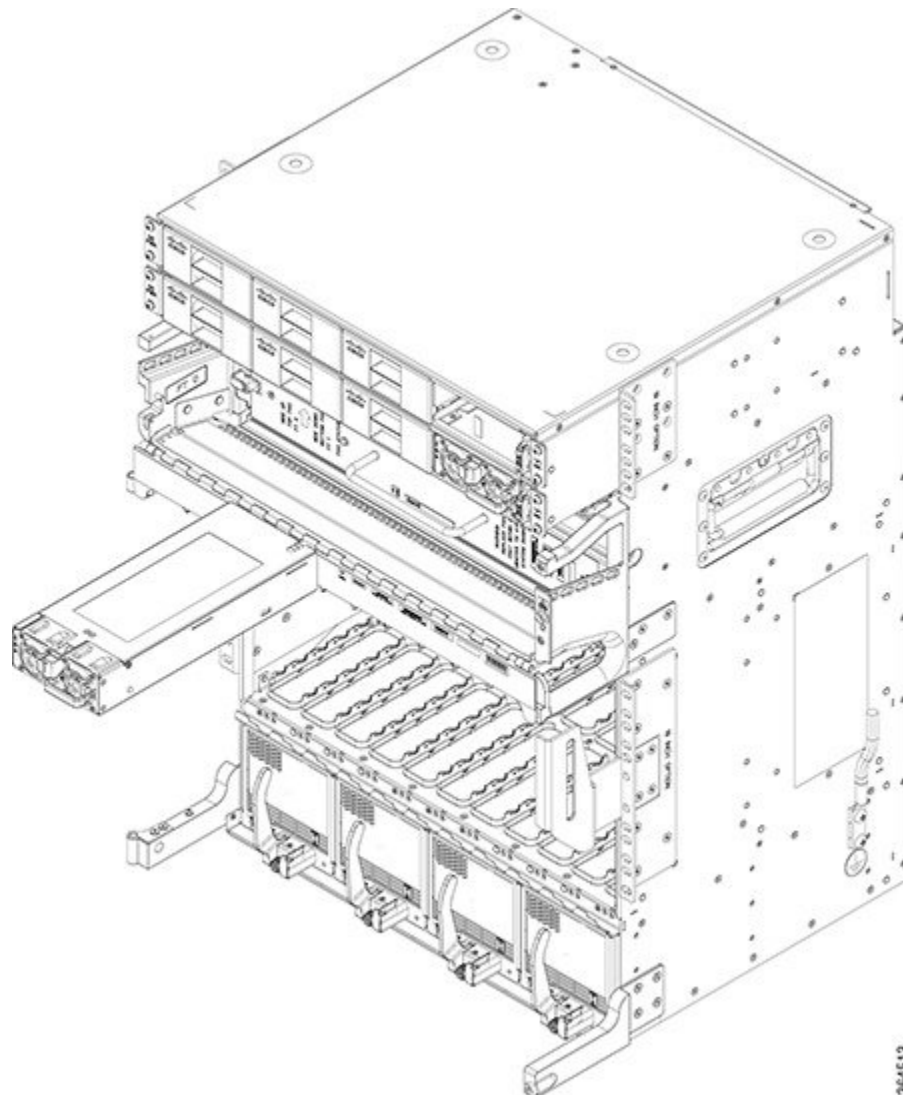

Replacing a Power Module

The following section describes how to replace a power module in a NCS 4009 chassis.

Following are the limitations when a Delta power module (DC power) is replaced with an ACBEL power module (DC power).

- Release 6.1.12 and 6.1.22 software do not support ACBEL PEM, so the FPD upgrade fails and show status is displayed as UPGD FAIL. However the power module will function normally.
- Release 6.1.32 and 6.1.42 software packages come with PSU FPD image version 3.01. Post upgrade, the ACBEL PEM FPD version is shown as 3.01, but it continues to function with its original image, that is, version 4.02.

Follow these steps to replace AC or DC power modules into the chassis:

Procedure

-
- Step 1** Using two hands to support the power module, slide it into the power tray.
- Step 2** Secure the power module into the power tray using the snap hook.
-

Removing the Air Filter

This section describes removing the air filter. The air filter is located in the bottom of the chassis behind the plastic grill.



-
- Note** The Cisco NCS 4009 chassis can have two types of air filters, depending on the fabric cards it houses.
- If the installed fabric card is, NCS4009-FC2-S, the air filter is NCS4009-FTF.
 - If the installed fabric card is, NCS4009-FC2F-S, the air filter is NCS4009-FTF-2.
-

The air filter prevents dust from the air in the room, to be drawn into the chassis by the fan tray. If it is damaged, dirty, or clogged with dust, they must be replaced with a new air filter. Failure to replace a compromised air filter can result in insufficient air circulation through the chassis and temperature-related environmental alarms.



-
- Caution** Never operate the Cisco NCS 4009 chassis without an air filter. Operating a Cisco NCS 4009 chassis without a filter for an extended time can result in damage to the chassis hardware.
-



Note First inspection of the air filter must be performed six months after the system installation. Air filters must be inspected every three months after the initial six month inspection and replaced if found to be dirty. Inspection of the air filter must be performed as specified in your local site practices. Spare filters must be kept in stock. The filter is sold in packs of 5.

Prerequisites

Before performing this task, open the front door, if installed.

Required Tools and Equipment

- ESD-preventive wrist strap
- Number-2 Phillips screwdriver
- Air filter (Cisco PID NCS4009-FTF or Cisco PID NCS4009-FTF-2)

Steps

To remove the air filter:

Procedure

-
- Step 1** For Cisco PID NCS4009-FTF, pull the spring-loaded plungers which are located on either side of the lower edge of the air filter. For Cisco PID NCS4009-FTF-2 , loosen the captive screws on the air filter.
- Step 2** Pull out the air filter.

Figure 7: Pulling Out the Air Filter (NCS4009-FTF) for NCS4009-FC2-S

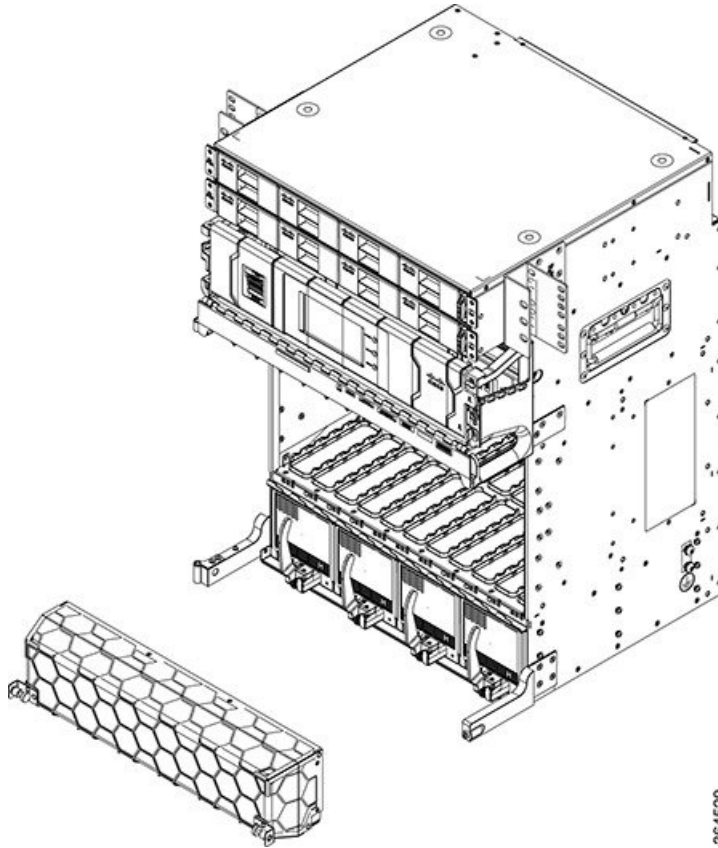
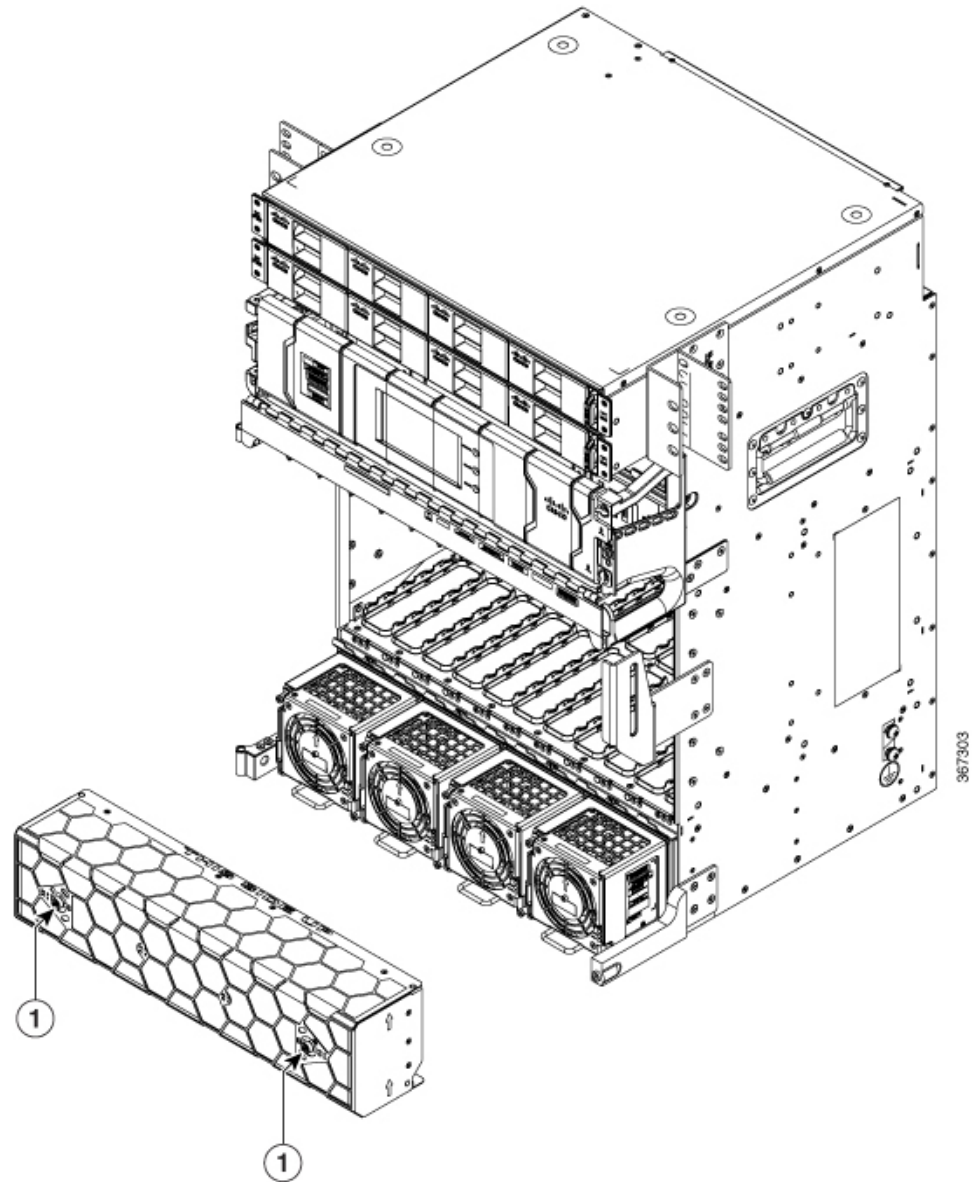

Figure 8: Pulling out the air filter (NCS4009-FTF-2) for NCS4009-FC2F-S



1	Captive screws
---	----------------

Replacing the Air Filter

To replace the air filter:



Note Verify air flow direction when installing the new air filter. An air flow direction arrow is indicated on the air filter frame and should be installed pointing up.

Procedure

-
- Step 1** Place the air filter in its position.
- Step 2** For Cisco PID NCS4009-FTF, release the two spring-loaded plungers which are on either side of the lower edge of the air filter. For Cisco PID NCS4009-FTF-2, tighten the two captive screws using 6 pound/force (lbf) inch (0.7 Nm torque).
-

Replacing the Front Door

This section describes removing and replacing the front door. The Cisco NCS 4009 chassis is shipped with the front door installed. Steps on how to install a key lock are also included.

Required Tools and Equipment

- ESD-preventive wrist strap
- Number 2 Phillips screwdriver, medium and small slot-head screwdrivers
- Front door

Steps

To remove the front door:

Procedure

-
- Step 1** Turn the knob to unlock the door.

Figure 9: Knob to Unlock Door

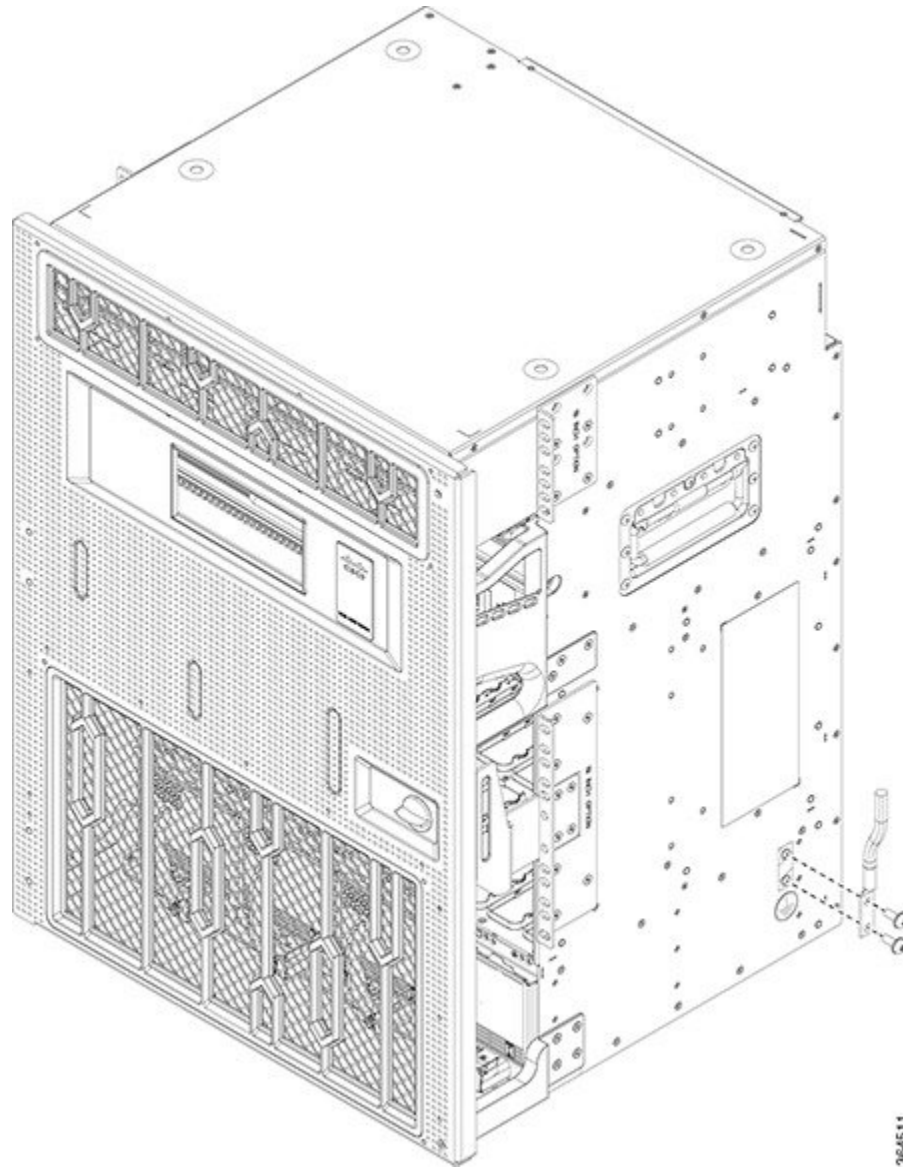

- Step 2** Open the door.
- Step 3** Loosen the screw to disconnect the ground cable

Figure 10: Disconnecting the Ground Cable

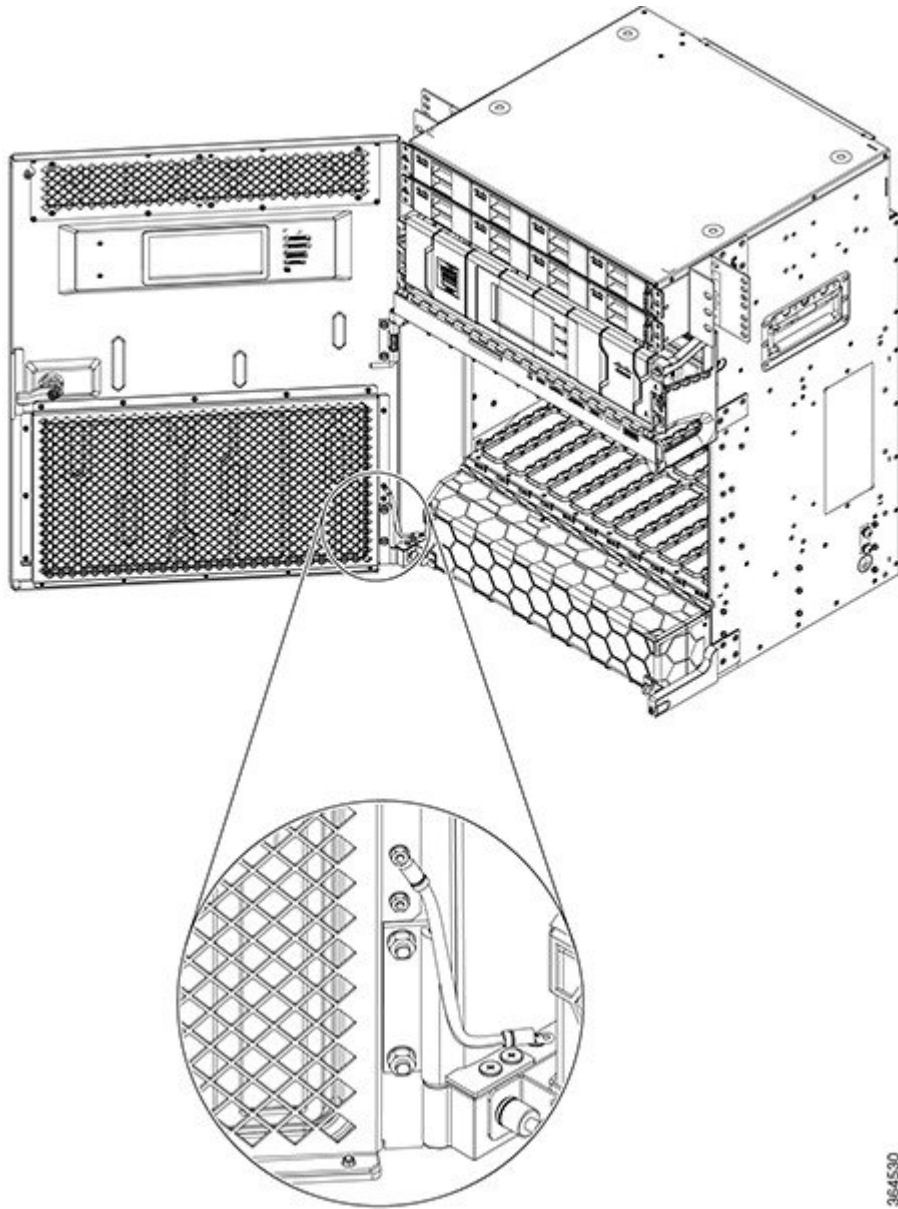

364530

Step 4 Move down the pin to release the door from the chassis hinge.

Figure 11: Pin to Release Door from Hinge

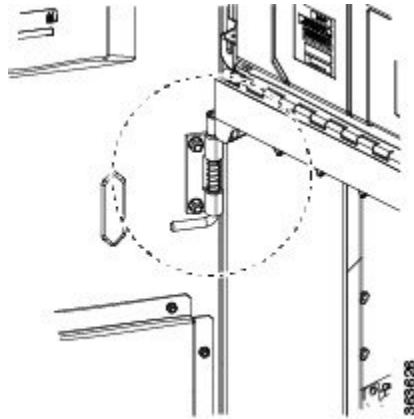

Step 5 Move up the door to release the bottom hinge pin .

Figure 12: Releasing the Bottom Hinge Pin

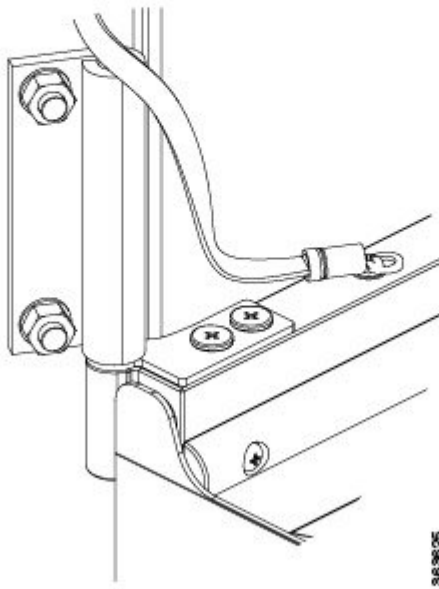

- Step 6** To replace the front door:
- Remove the screw and washer from the chassis fixing point.

Figure 13: Installing the Door Ground Strap Retrofit Kit

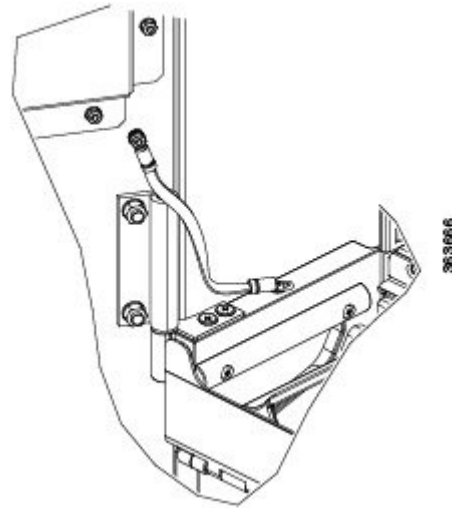

- b) Feed the screw through the ground cable ring lug, through the washer, and then into the machined block.
- c) Using a Philips screwdriver, insert and tighten the screws.

Figure 14: Shelf Assembly with Door Ground Strap Retrofit Kit Installed (ANSI)

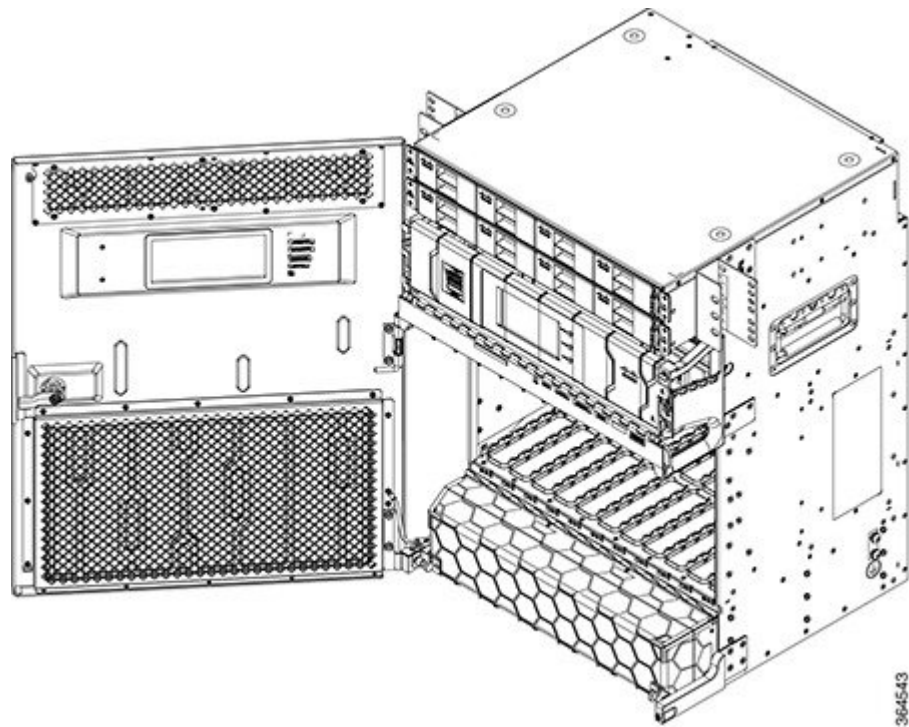

- d) Swing the door closed and turn the knob to lock.

Step 7

To install the optional key lock:

- a) Open the door.
- b) Disassemble the keyless block.

On the rear of the door, loosen the screw and remove the retention feature (latch), lock washer and M22 nut and then, on the front of the door, pull out the keyless block.

Figure 15: Disassembling the keyless block

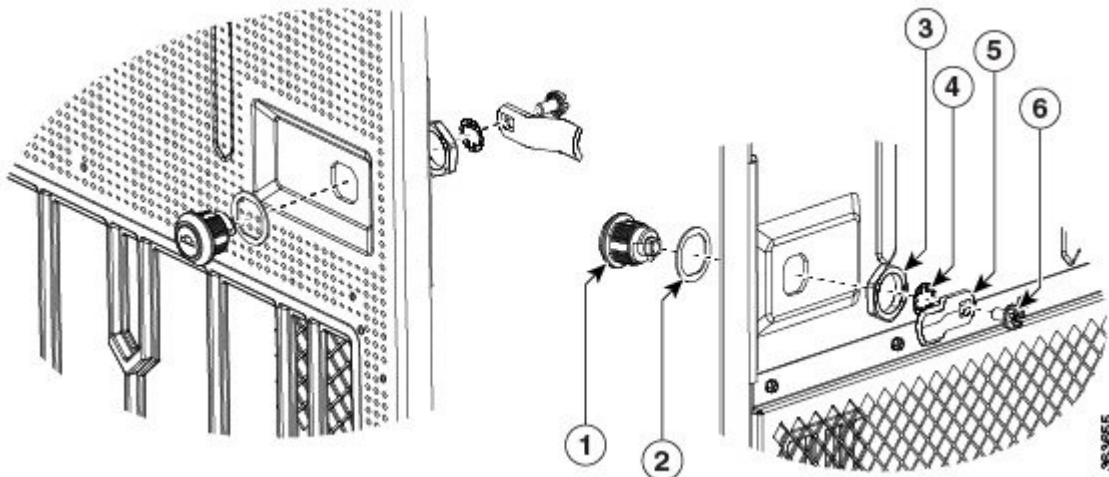

1- Keyless block	2- Washer
3- M22 nut	4- Lock washer
5- Retention feature	6- Screw

c) Assemble the key block.

On the front of the door, insert the key block and the front washer and then, on the rear side of the door, lock the retention M22 nut, insert the lock washer and retention feature (latch), and tighten the screw.

Removing the Fan Tray



Warning When servicing the system you must remove the fan tray and replace it in under a minute.



Caution For Online Insertion and Removal (OIR) of the fan tray, the maximum time limit is 67 seconds. Violating this limit, results in shutting down of the line cards.



Note When all the four AFTs (NCS4009-FAN-FC) are present along with the fan tray (NCS4K-FTA) in the chassis, the OIR for the fan tray is five minutes.

This section describes how to remove the fan tray shipped with the Cisco NCS 4009 chassis.



Note To replace the fan tray, it is not necessary to move any of the cable management facilities.

Prerequisites

Before performing this task, open the front door, if installed.

Required Tools and Equipment

- ESD-preventive wrist strap
- 6-inch, number-1 Phillips screwdriver
- Fan tray (Cisco PID NCS4K-FTA=)

Steps



Caution Do not force a fan tray into place. Doing so can damage the connectors on the fan tray and/or the connectors on the backplane.

To remove the fan tray:

Procedure

- Step 1** Loosen the two captive screws that hold the fan tray in place.
- Step 2** Rotate the ejectors down or up, depending upon which fan tray you are removing (top or bottom).
- Step 3** Slide the fan tray out of the slot.

Warning **The fans might still be turning when you remove the fan assembly from the chassis. Keep fingers, screwdrivers, and other objects away from the openings in the fan assembly's housing.** Statement 263



Note When the primary fan tray is removed, all the AFTs in the chassis run at maximum speed.

Replacing the Fan Tray

To replace the fan tray:

Procedure

Step 1 Orient the fan tray as specified on front label.

Figure 16: Fan Tray, Arrow Facing Up

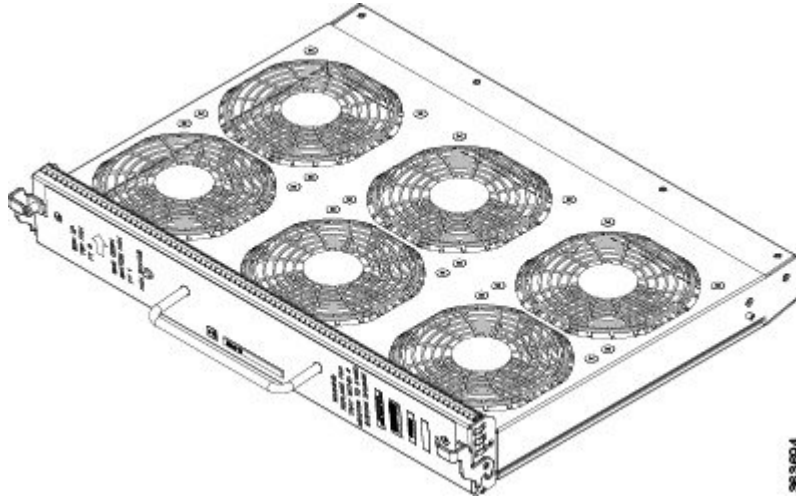

Step 2 Move the ejectors up or down into the stop or block position.

Step 3 Slide the fan tray into the chassis slot. Tilt the fan tray up when the fan tray is at an inch distance before it slides completely.

Figure 17: Fan Tray Inserted into Chassis

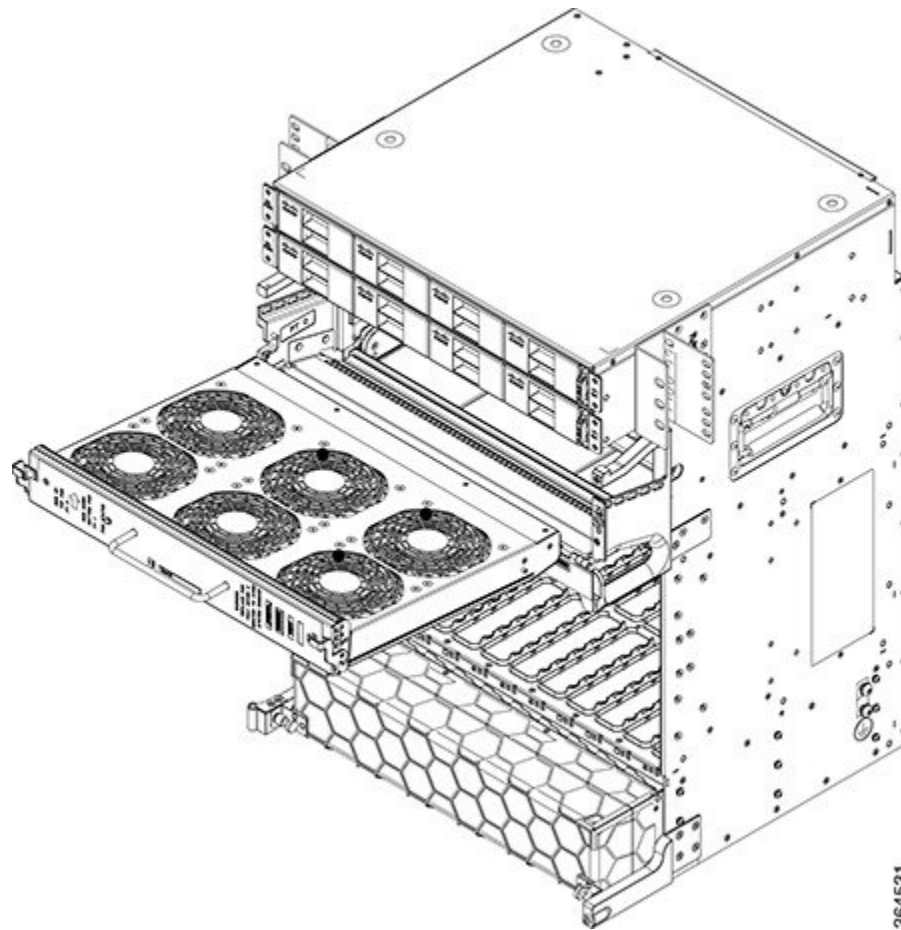

- Step 4** Check the ejector engagement to be sure it is correct. Complete the ejectors rotation to fully insert the fan tray.
- Step 5** Tighten the two captive screws to lock the fan tray in place.

Removing and Replacing the Craft Panel

This section describes how to remove and replace the craft panel. The Cisco NCS 4009 chassis is shipped with the craft panel installed. Normally, it is not necessary to remove the craft panel. However, it can be removed. The craft panel is a field replaceable unit.

Prerequisites

Before performing this task, open the front door, if installed.

Required Tools and Equipment

- ESD-preventive wrist strap
- 6-inch, number-1 Phillips screwdriver

Steps

To remove the craft panel:

Procedure

Step 1 Loosen the two wing-head screws on the right side.

Figure 18: Craft Panel Showing Wing-Head Screws

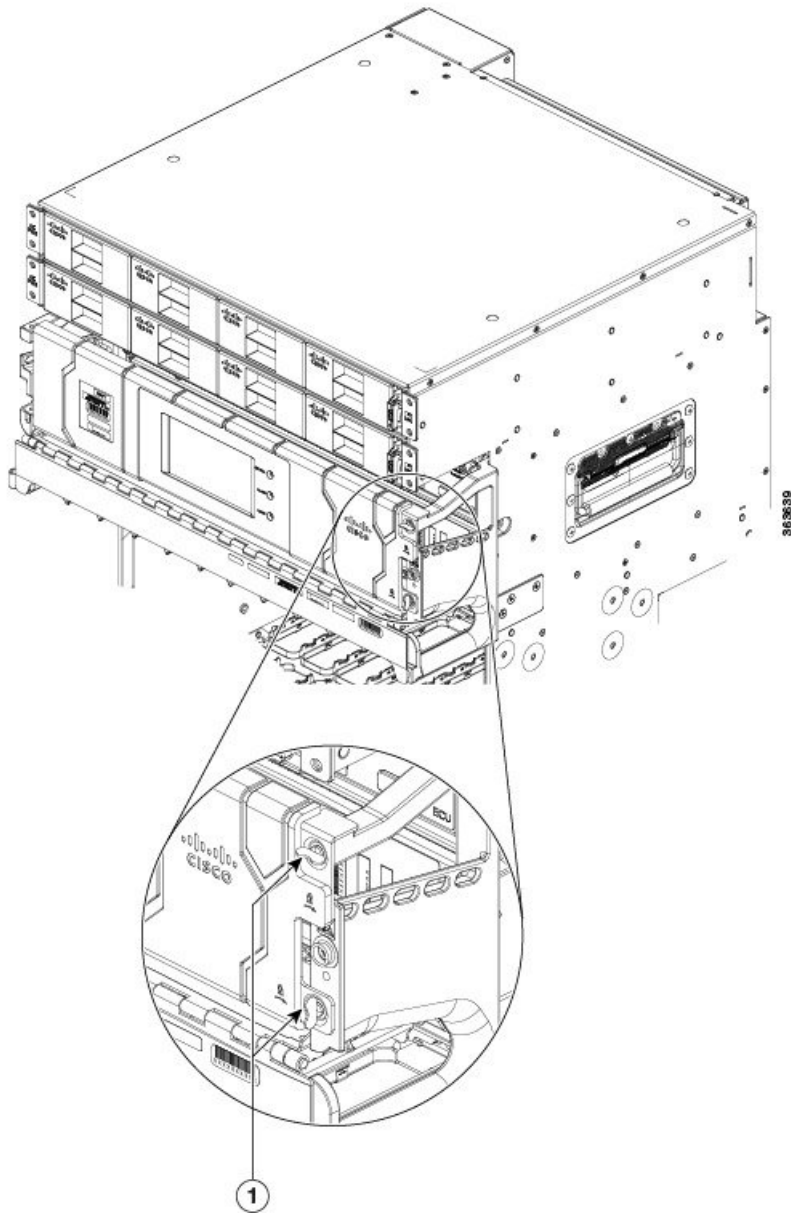

1	Wing head screws
---	------------------

Step 2 Open the craft panel and rotate it .

Figure 19: Opening the Craft Panel

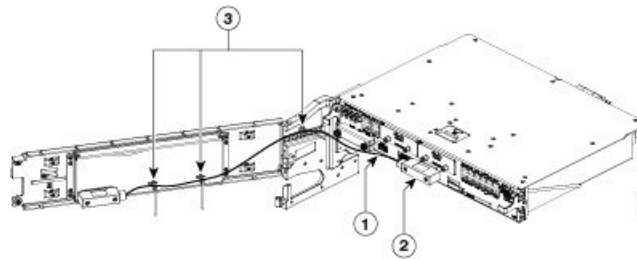

1	Craft cable
2	Connector
3	Three cable ties to hold the LCD cables

Step 3 Disconnect the craft cable from the ECU faceplate.

Step 4 Loosen the two connector screws and remove the connector.

Step 5 Remove the craft panel. Lift up the panel to disengage the hinge pins on the left side from the chassis.

Replacing the Craft Panel

To replace the craft panel:

Procedure

Step 1 Engage the hinge pins on the left side of the chassis.

Step 2 Connect the craft cable to the ECU faceplate.

Step 3 Tighten the two connector screws to a torque value of 4.4lbs.

Step 4 Close the craft panel and rotate it.

Step 5 Tighten the two wing-head screws on the right side.

Routing the BITS Cables

Route the BITS cables according to the following image.

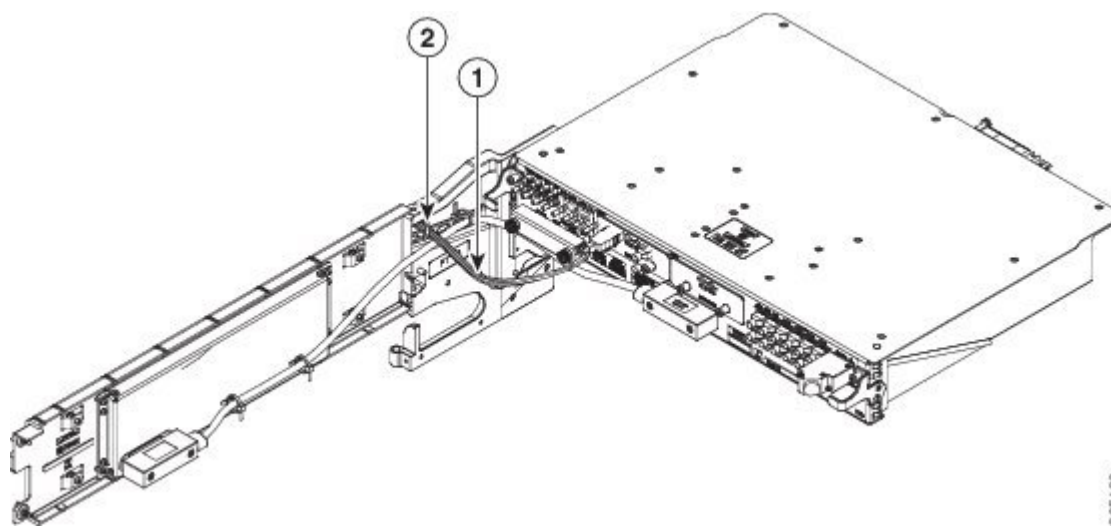

1	Routing of BITS cables
2	Cable tie to hold the BITS cables

Removing the External Connection Unit

This section describes how to remove the external connection unit (ECU). The ECU provides all shelf electrical I/O connectivity to the active and standby route-processor line cards. The Cisco NCS 4009 chassis is shipped with the ECU installed.

Prerequisites

- Open the front door, if installed.
- Make sure that the craft panel has been removed. See the [Removing and Replacing the Craft Panel](#), on page 29.

Required Tools and Equipment

- ESD-preventive wrist strap
- 6-inch, number-1 Phillips screwdriver
- ECU (Cisco PID NCS4K-ECU=)

Steps

To remove the ECU:

Procedure

-
- Step 1** Disconnect all cables from the ECU faceplate.
 - Step 2** Loosen the two captive screws.

Figure 20: ECU

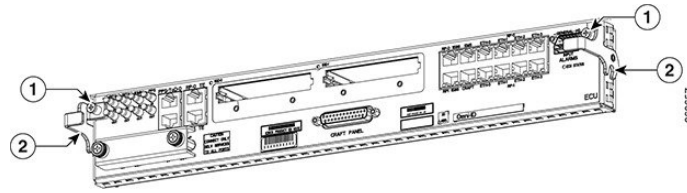

1	Captive screw	2	Ejector
---	---------------	---	---------

- Step 3** Rotate the ejectors to point down.
- Step 4** Grasp the upper and lower portions of the ECU with fingers to pull out the ECU from the chassis.

Replacing the External Connection Unit

To replace the ECU:

Procedure

- Step 1** Rotate the ejectors to point down.
- Step 2** Push the ECU into the chassis.
- Step 3** Rotate the ejectors to point up.
- Step 4** Tighten the two captive screws.
- Step 5** Connect all cables to the ECU faceplate.

Replacing an SSD

The ECU houses two 2.5-in. solid-state drives (SSDs).

Prerequisites

- Open the front door, if installed.
- Make sure that the ECU is installed. See the [Routing the BITS Cables](#), on page 31.

Required Tools and Equipment

- ESD-preventive wrist strap
- 6-inch, number-1 Phillips screwdriver
- SSDs (Cisco PID NCS4K-SSD-100G or NCS4K-SSD-200G=)

Steps

To remove an SSD:

Procedure

Step 1 Loosen the two captive screws.

Figure 21: Captive Screws on the SSD

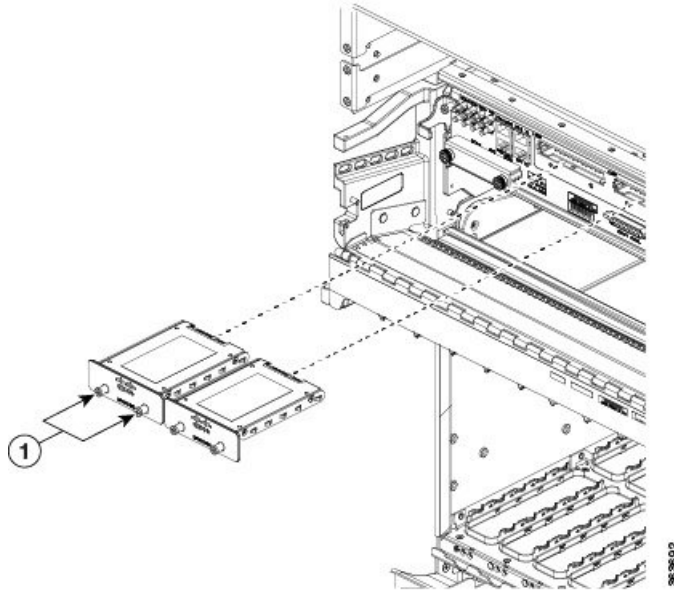

1	Captive screws
---	----------------

Step 2 Slide out the SSD from the ECU slot.

What to do next

To replace a SSD, slide the SSD into the ECU slot and tighten the two captive screws to secure the SSD into place.