



Unpacking the Router

This section includes instructions about how to unpack the Cisco 1240 Connected Grid Router and describes the items that ship with the router.

These topics are discussed:

- [Unpacking the Router, page 1](#)
- [Router Package Contents, page 1](#)

Unpacking the Router

Tip: When you unpack the router, do not remove the foam blocks attached to antennas and antenna connectors. The foam protects the antennas and connectors during installation.

To unpack the router:

1. Open the shipping container and carefully remove the contents.
2. Return all packing material to the shipping container, and save it.
3. Ensure that all items listed in the [Router Package Contents, page 1](#) are included in the shipment. If any item is damaged or missing, notify your authorized Cisco sales representative.

Router Package Contents

Your router kit contains the items listed in [Table 1 on page 2](#).

Note: Some items are optional and might not be included with the router if they were not ordered with the router.

Table 1 Cisco 1240 Connected Grid Router Package Contents

Qty.	Item	Description
1	Cisco CGR 1240	<p>Router enclosure, with the following components installed:</p> <ul style="list-style-type: none"> ■ Connected Grid Modules, page 115 (1 to 4, depending on configuration ordered) ■ GPS Antenna, page 123 ■ WiFi Antenna, page 123 ■ Connected Grid Module Antennas, page 124 (1 to 7, depending on configuration ordered) ■ 2-GB SD Flash Memory Module, page 133 ■ AC Power Supply, page 26 (Power cable part number CGR-PWRCORD-NA or CGR-PWRCORD-EU must be ordered separately). ■ Battery Backup Units, page 141 (0 to 3, depending on configuration ordered)
1	Console cable	RJ-45-to-DB-9
1	Grounding kit	<p>Grounding lug and two screws.</p> <p>See Grounding Hardware, page 70.</p>
1	Cable glands kit	<p>Includes:</p> <ul style="list-style-type: none"> ■ One cable gland (more can be ordered, see table 10) ■ One tube of anti-seize compound
1	Mounting bracket kit	<p>Includes:</p> <ul style="list-style-type: none"> ■ Mounting bracket ■ Mounting bracket security panel ■ Required hardware <p>For details, see Mounting Bracket Kit, page 47.</p>
Optional Items (Ordered Separately)		
1	Pole mount kit	<p>Includes:</p> <ul style="list-style-type: none"> ■ Mounting plate ■ Two clamp brackets ■ Required hardware <p>See Pole Mount Kit, page 46.</p>
1	Band strap kit	<p>Two steel straps.</p> <p>See Band Strap Kit, page 48.</p>
1	Strap tool kit	<p>BAND-IT strap tool.</p> <p>See Strap Tool Kit, page 49.</p>
1	Antenna plug	CGR-ANT-PLUG



Installation Safety and Site Preparation

This section contains safety and site preparation information.

Note: Read this entire section before installing the router.

These topics are discussed:

- [Safety Recommendations, page 3](#)
- [Safety with Electricity, page 3](#)
- [Preventing Electrostatic Discharge Damage, page 4](#)
- [Safety Warnings, page 4](#)
- [Site Requirements, page 5](#)
- [Power Guidelines and Requirements, page 6](#)
- [Preparing for Network Connections, page 6](#)
- [Required Tools and Equipment for Installation and Maintenance, page 7](#)

Safety Recommendations

To ensure general safety, follow these guidelines:

- Keep the chassis area clear and dust-free during and after installation.
- Keep tools and chassis components away from walk areas.
- Do not wear loose clothing that could get caught in the chassis. Fasten your tie or scarf and roll up your sleeves.
- Wear safety glasses when working under conditions that might be hazardous to your eyes.
- Do not perform any action that creates a hazard to people or makes the equipment unsafe.

Safety with Electricity

Follow these guidelines when working on equipment powered by electricity:

- Read all warnings in [Safety Warnings, page 4](#).
- Locate the emergency power-off switch for your installation location. If an electrical accident occurs, you can quickly turn off the power.
- Disconnect all power before doing the following:
 - Installing or removing a chassis
 - Working near power supplies

-
- Look carefully for possible hazards in your work area, such as moist floors, ungrounded power extension cables, frayed power cords, and missing safety grounds.
 - Do not work alone if hazardous conditions exist.
 - Never assume that power is disconnected from a circuit. Always check.
 - Never open the enclosure of the router internal power supply.
 - If an electrical accident occurs, proceed as follows:
 - Use caution; do not become a victim yourself.
 - Turn off power to the device.
 - If possible, send another person to get medical aid. Otherwise, assess the victim's condition and then call for help.
 - Determine if the person needs rescue breathing or external cardiac compressions; then take appropriate action.

Preventing Electrostatic Discharge Damage

Electrostatic discharge (ESD) can damage equipment and impair electrical circuitry. It can occur if electronic printed circuit cards are improperly handled and can cause complete or intermittent failures. Always follow ESD prevention procedures when removing and replacing modules:

- Ensure that the router chassis is electrically connected to earth ground.
- Wear an ESD-preventive wrist strap, ensuring that it makes good skin contact. Connect the clip to an unpainted surface of the chassis frame to channel unwanted ESD voltages safely to ground. To guard against ESD damage and shocks, the wrist strap and cord must operate effectively.
- If no wrist strap is available, ground yourself by touching a metal part of the chassis.

Caution: For the safety of your equipment, periodically check the resistance value of the antistatic strap. It should be between 1 and 10 megohms (Mohm).

Safety Warnings

This section contains important safety warnings for the installation and use of the router.

Translated versions of all safety warnings are available in the safety warnings document that shipped with your router, and which is available on Cisco.com.

Warning: IMPORTANT SAFETY INSTRUCTIONS

This warning symbol means danger. You are in a situation that could cause bodily injury. Before you work on any equipment, be aware of the hazards involved with electrical circuitry and be familiar with standard practices for preventing accidents. Use the statement number provided at the end of each warning to locate its translation in the translated safety warnings that accompanied this device. Statement 1071

Warning: In order to comply with FCC radio frequency (RF) exposure limits, antennas for this product should be located a minimum of 7.9 in. (20 cm) or more from the body of all persons. Statement 332

Warning: Do not operate the unit near unshielded blasting caps or in an explosive environment unless the device has been modified to be especially qualified for such use. Statement 364

Warning: This equipment must be externally grounded using a customer-supplied ground wire before power is applied. Contact the appropriate electrical inspection authority or an electrician if you are uncertain that suitable grounding is available. Statement 366

Warning: Do not work on the system or connect or disconnect cables during periods of lightning activity.
Statement 1001

Warning: Read the installation instructions before connecting the system to the power source. Statement 1004

Warning: This product relies on the building's installation for short-circuit (overcurrent) protection. Ensure that the protective device is rated not greater than 20 A. Statement 1005

Warning: This unit is intended for installation in restricted access areas. A restricted access area can be accessed only through the use of a special tool, lock and key, or other means of security. Statement 1017

Warning: Only trained and qualified personnel should be allowed to install, replace, or service this equipment.
Statement 1030

Warning: Ultimate disposal of this product should be handled according to all national laws and regulations.
Statement 1040

Warning: Installation of the equipment must comply with local and national electric codes. Statement 1074

Site Requirements

This section describes the requirements your site must meet for safe installation and operation of your router. Ensure that the site is properly prepared before beginning installation. If you are experiencing shutdowns or unusually high errors with your existing equipment, this section can also help you isolate the cause of failures and prevent future problems.

Pole-Top Installation Requirements

These installation steps (see [Installing the Router, page 85](#)) require that the router mounting and installation locations, usually at the top of a power or other utility pole, have the following connections available for basic router installation:

- AC power connection
- Fast Ethernet connection, as described in [Ethernet Connections, page 6](#)

Environmental Requirements

The location of your router is an important consideration for proper operation. Equipment placed too close together, inadequate ventilation, and inaccessible panels can cause malfunctions and shutdowns, and can make maintenance difficult. Plan for access to both power supply side and cable side panels of the router.

If you are currently experiencing shutdowns or an unusually high number of errors with your existing equipment, these precautions and recommendations may help you isolate the cause of failure and prevent future problems.

- Always follow ESD-prevention procedures described in [Preventing Electrostatic Discharge Damage, page 4](#) to avoid damage to equipment. Damage from static discharge can cause immediate or intermittent equipment failure.
- Ensure that the chassis door closes securely and that all empty module slots and have filler panels installed.
- When other equipment is installed on or connected to the router, try operating the router by itself, if possible. Power off other equipment (such as USB devices and installed third-party modules) to allow the router under test a maximum of cooling air and clean power.

FCC Safety Compliance Statements

The FCC, with its action in ET Docket 9608, has adopted a safety standard for human exposure to RF electromagnetic energy emitted by FCC-certified equipment. When used with approved Cisco antennas, Cisco products meet the uncontrolled environmental limits found in OET-65 and ANSI C95.1, 1991. Proper operation of this radio device according to the instructions in this publication results in user exposure substantially below the FCC recommended limits.

1. Two or more modular transmitters with FCC ID: N7NMC8705, only one (1) of which may transmit simultaneously with other transmitters types.
2. Two or more modular transmitters with FCC ID: SK9ITR9002, only one (1) of which may transmit simultaneously with all other transmitters types.
3. Based on the FCC limits and operational parameters of the CGR1240, the CGR can safely be operated without any minimum distance restrictions under normal operational parameters. The FCC limits and analysis utilizes the worst case -i.e. 100% RF transmit duty cycle. Therefore based on normal operational parameters the actual duty cycle calculations the RF exposure is much lower and negligible.

Power Guidelines and Requirements

- Check the power at your site to ensure that you are receiving power that is free of spikes and noise.
- Install a power conditioner if necessary.
- Confirm that the AC input power supply has a 110 VAC nominal, 1.0 A rms or 220 VAC nominal 0.5 A rms output sourcing capability.

Preparing for Network Connections

When setting up your router, consider distance limitations and potential electromagnetic interference (EMI) as defined by the applicable local and international regulations.

Network connection considerations are provided for several types of network interfaces and are described in the following sections:

- [Ethernet Connections, page 6](#)
- [Serial Connections, page 7](#)

Ethernet Connections

The IEEE has established Ethernet as standard IEEE 802.3. The router supports the following Ethernet implementations:

- 1000BASE-X—1000 Mb/s full-duplex transmission over a fiber optics cable. Supports the Ethernet maximum length of 328 feet (100 meters).
- 1000BASE-T—1000 Mb/s full-duplex transmission over a Category 5 or better shielded twisted-pair (STP) cable (IEEE 802.3ab). Supports the Ethernet maximum length of 328 feet (100 meters).
- 100BASE-TX—100 Mb/s full-duplex transmission over a Category 5 or better shielded twisted-pair (STP) cable (IEEE 802.3u). Supports the Ethernet maximum length of 328 feet (100 meters).

For more information about Ethernet connections and cables, see:

- For cable and connector pinouts, see [Connector and Cable Specifications, page 195](#).
- For cabling guidelines, see [Installing the Router, page 85](#).

Serial Connections

RS232 and RS485 serial connections are provided by router serial ports, as described in [Router Hardware Description, page 9](#).

Exterior 10/100BASE-T Fast Ethernet Port

The router exterior Ethernet connector is compliant with Open DeviceNet Vendor Association (ODVA) standards. Cables used with this port must also comply with the ODVA standards. ODVA-compliant cables and connectors meet IP 67 ratings.

Required Tools and Equipment for Installation and Maintenance

These sections list tools and materials that you must supply to perform the following procedures:

- [Mounting the Router, page 45](#)
- [Installing the Router, page 85](#)
- [Opening and Closing the Router Chassis, page 75](#)
- [Installing Battery Backup Units \(BBUs\), page 141](#)
- [Installing External Non-Cisco Modules, page 173](#)

See the Cisco Connected Grid modules installation and configuration guides for the tools and equipment you must supply to install modules, at: www.cisco.com/go/cg-modules



Router Hardware Description

This section describes the major hardware features of the Cisco 1240 Connected Grid Router (CGR 1240 or router), including the chassis, internal and external connectors and ports, and hardware specifications.

These topics are discussed:

- [Router Overview, page 9](#)
- [Hardware Features Detailed Description, page 22](#)

Router Overview

- [Router Applications Overview, page 9](#)
- [Router Hardware Overview, page 10](#)
- [Hardware Compliance, page 21](#)

Router Applications Overview

The CGR 1240 is a ruggedized communication platform, designed for use in Field Area Network (FAN) power distribution grids that require outdoor, pole-mounted routers. The FAN is a distribution system in which power generation and transmission are linked to the power consumers.

The router provides an end-to-end communication network that enables increased power grid efficiency and reliability, reduced energy consumption, and reduced greenhouse gas emissions. The router can be leveraged across applications including:

- Advanced Metering Infrastructure (AMI)
- Distribution Automation (DA)
- Integration of Distributed Energy Resources (DER)
- Remote Workforce Automation
- Public Lighting

The router provides reliable and secure real-time communication between the FAN systems and the numerous devices that exist on the FAN, including meters, sensors, protection relays, Intelligent Electronic Devices (IEDs), plug-in electric vehicle (PEV) charging stations, and distributed solar farms. Network data is forwarded and processed over secure communication links between devices within the distribution grid for local decision processing.

Additionally, this data is sent to Supervisory Control and Data Acquisition (SCADA) and other management systems. The router supports physical connection to legacy Data Acquisition devices (over the serial port); the data from these devices can also be sent to central SCADA systems using protocol translation over the IP network.

Router Hardware Overview

Table 2 on page 10 describes the hardware features of the router.

Table 2 CGR 1240 Hardware Features

Hardware Feature	Description
4 -Connected Grid Module Slots, page 29	The slots are for ruggedized Connected Grid modules that provide connectivity to the NAN endpoints and to the WAN, for connectivity to the utility control center.
4 x Fast Ethernet Ports, page 32 2 x Gigabit Ethernet Ports, page 32	Ethernet connections to the backhaul network and other IP network devices.
2 - Integrated Serial Ports, page 36	RS232/RS485 serial ports for optional connections to legacy devices, such as RTUs.
Chassis Enclosure, page 22	An RJ-45 console port provides local access to the router for management and administration tasks.
SD Flash Memory Module, page 25	An external, default 2-GB SD card stores the router system software and configurations.
Automatic Battery Backup	Up to 12 hours of battery backup power in the event of an AC power failure.
USB Ports, page 39	Two Type A USB ports for connecting to USB storage or other devices, and providing power to any connected device.
GPS Module, page 41	An integrated GPS provides accurate time and location information to the system.
WiFi Short-Range Access Point, page 43	An integrated wireless access point supports short range wireless access to the router, enabling local management over a WiFi connection to the router from outside the substation or utility box.
Mounting Features	Support for pole mounting on utility poles of varying diameter and materials.
4 x Connected Grid Module Slots, page 29	Ruggedized Connected Grid modules provide connectivity to the NAN endpoints and to the WAN, for connectivity to the utility control center.

The CGR 1240 hardware assembly is shown in [Figure 1 on page 11](#).

Figure 1 Cisco 1240 Connected Grid Router with Integrated Antennas Installed

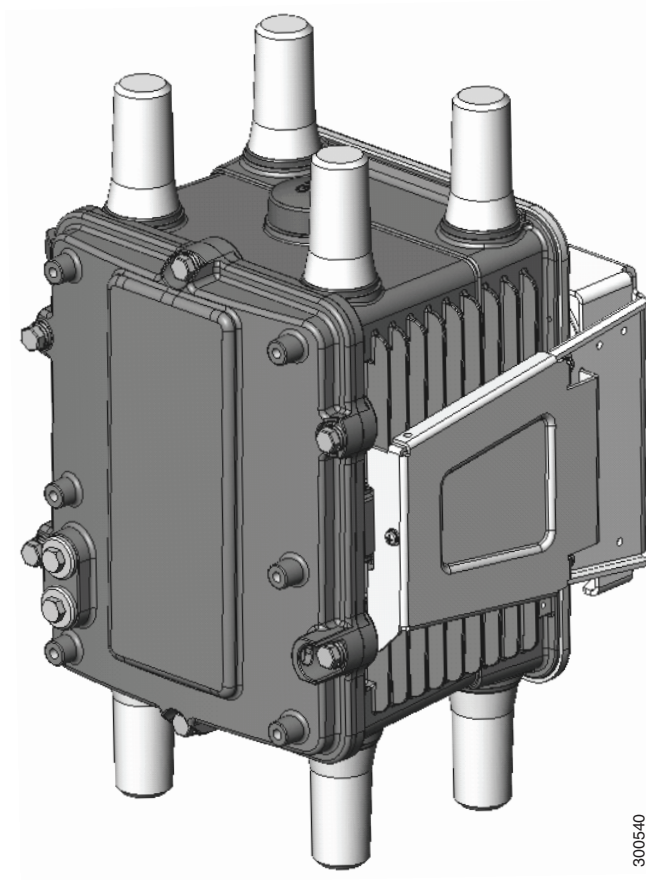

This section contains:

- [Exterior Hardware Overview, page 11](#)
- [Interior Hardware Overview, page 17](#)
- [CGR1240 Filler Panels, page 20](#)

Exterior Hardware Overview

This section illustrates the router exterior hardware features and includes a brief description of each feature. Detailed descriptions of each feature are in the [Hardware Features Detailed Description, page 22](#).

Figure 2 Router Front Exterior

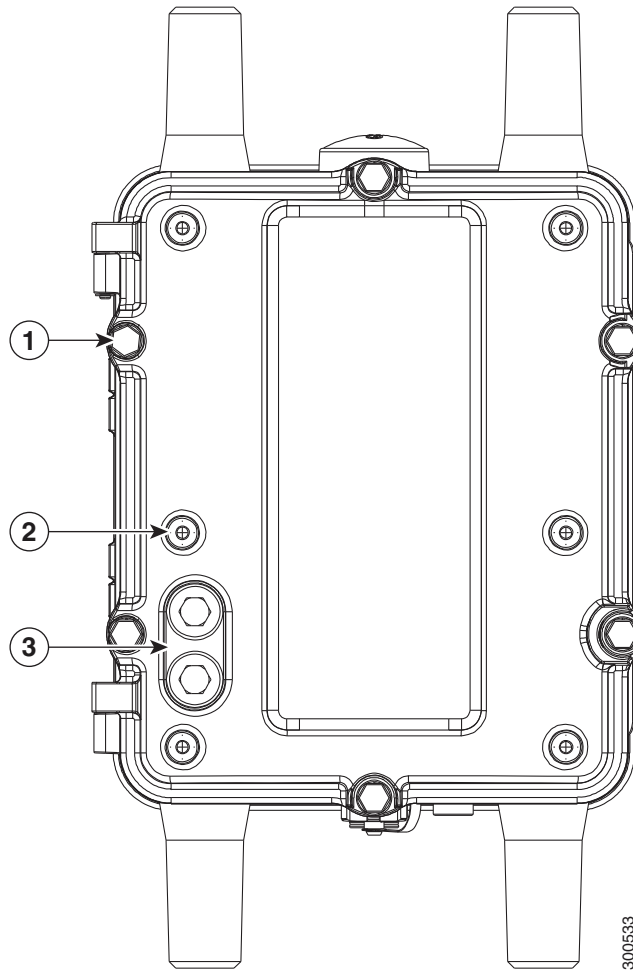

Table 3 Router Front Exterior Features

Item	Description	Detailed Information
1	M8 captive bolts (8)	Loosen these bolts to access the router interior. See Opening and Closing the Router Chassis, page 75 .
2	Module mounting bosses (6)	Mount a supported non-Cisco module (optional) to the front exterior of the router using these mounting bosses. See Installing External Non-Cisco Modules, page 173 .
3	Module cable ports (2)	Thread cables through these ports, to ports and connectors inside the router, when installing a module on the router exterior. See Installing External Non-Cisco Modules, page 173 .

Figure 3 Router Front with Mounting Bracket and Door Lock Post

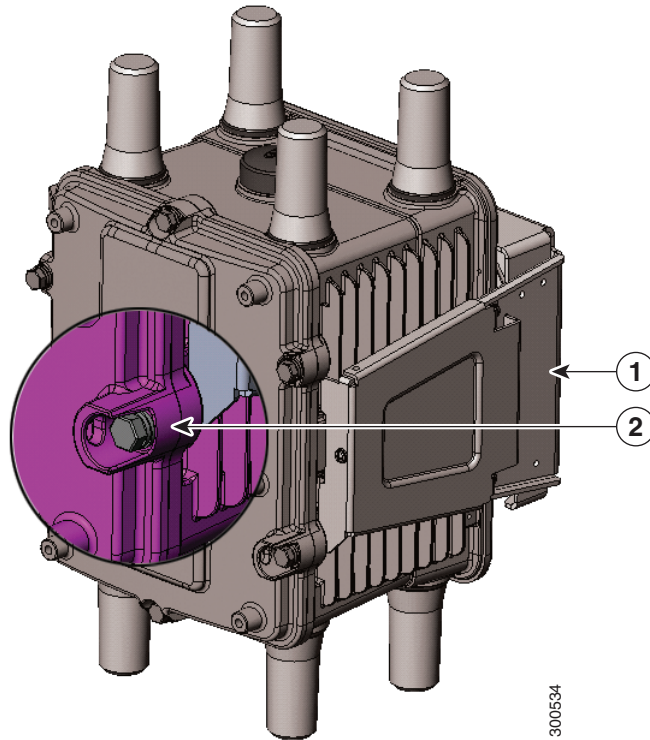

Table 4 Router Bracket and Lock Features

Item	Description	Detailed Information
1	Mounting bracket	Use the mounting bracket with the Cisco pole mount kit to install the router on a pole. For router mounting options and procedures, see Mounting the Router, page 45 .
2	Door lock post	Use the door lock post to install a lock on the router door to prevent unauthorized access to the router interior. See Opening and Closing the Router Chassis, page 75 .

Figure 4 Router Right Side Exterior

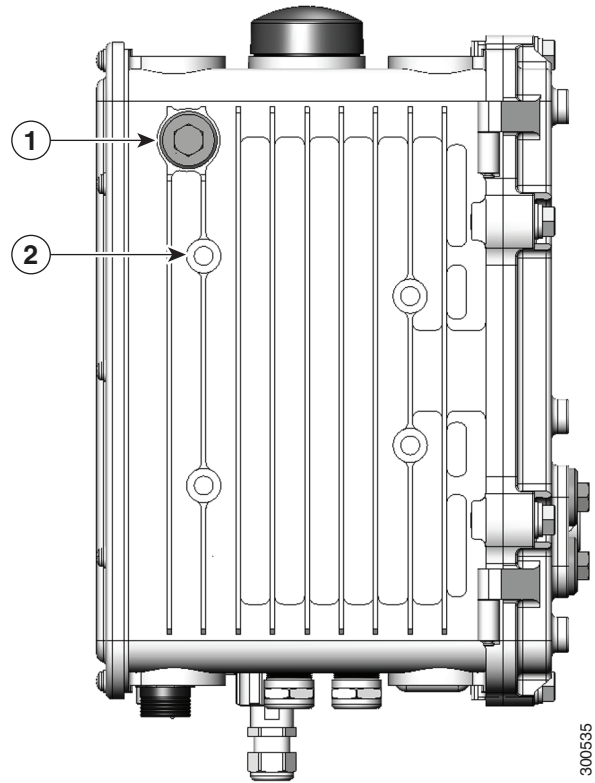

Table 5 Router Right Side Exterior Features

Item	Description	Detailed Information
1	Console port access	Remove the plug shown here to access the console port. This port is described in Console Port, page 24 . See Installing the Router, page 85 .
2	Mounting bracket posts (4)	Attach supported brackets to the router using these mounting posts. See Mounting the Router, page 45 .

Figure 5 Router Left Side Exterior

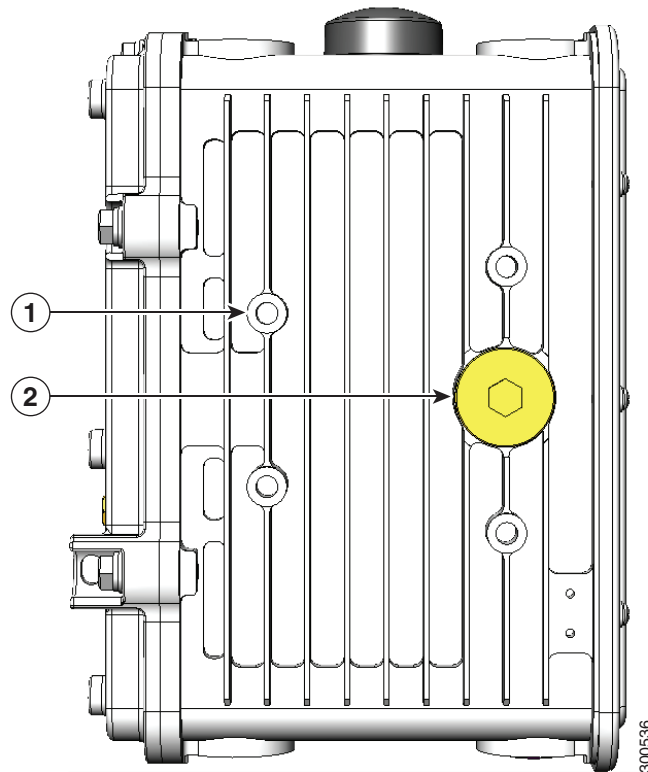

Table 6 Router Left Side Exterior Features

Item	Description	Detailed Information
1	Mounting bracket posts (4)	Attach supported brackets to the router using these mounting posts. See Mounting the Router, page 45 .
2	SD flash memory module port	Remove the plug shown here for access to the router SD module as described in SD Flash Memory Module, page 25 . For detailed information about using an SD flash memory module with the router, see Using the SD Flash Memory Module, page 133 . Note: When a mounting bracket is installed on the router, the bracket blocks access to the SD card port. To access the port after the bracket is installed, you must remove 3 of the bolts that attach the bracket to the router, and rotate the bracket away from the port. See Mounting the Router, page 45 .

Figure 6 Router Top Exterior

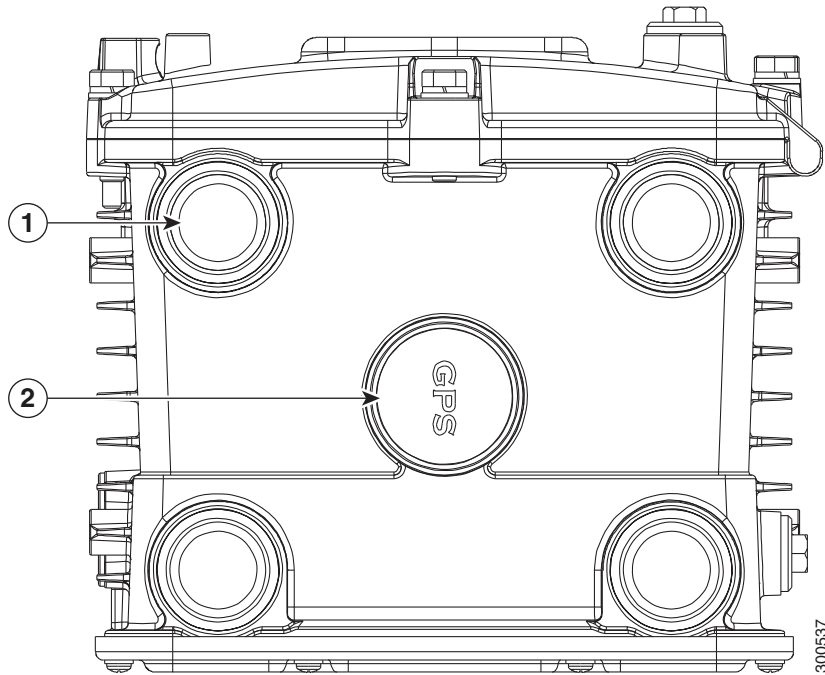

Table 7 Router Top Exterior Features

Item	Description	Detailed Information
1	Antenna connectors (4)	Install supported integrated or external antennas in these ports. For information on the router antennas, including how to find installation instructions, see Antennas, page 121 .
2	GPS antenna	The GPS antenna connects the router GPS (as described in GPS Module, page 41) to the GPS source. See GPS Antenna, page 123 for specifications and supported frequencies.

Figure 7 Router Base Exterior

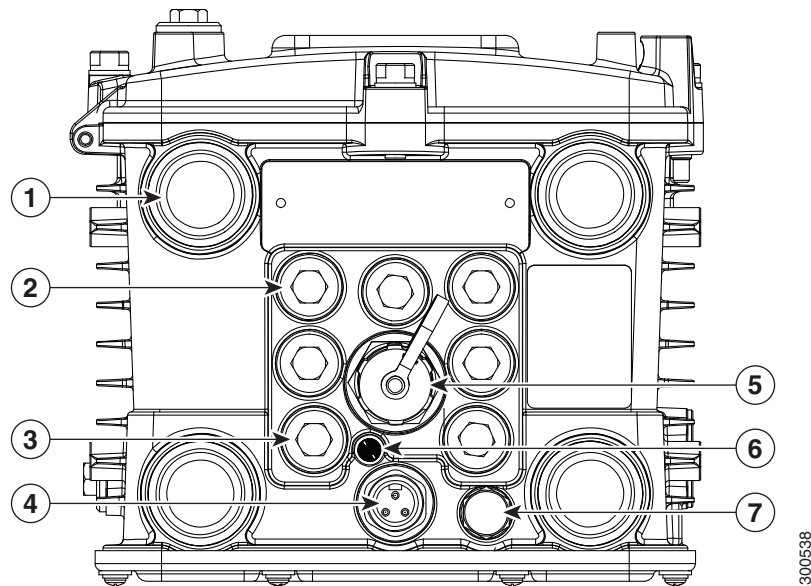

Table 8 Router Base Exterior Features

Item	Description	Detailed Information
1	Antenna connectors (4)	Install supported integrated or external antennas in these ports. For information on the router antennas, including how to find installation instructions, see Antennas, page 121 .
2	Cable ports (7)	Use a cable glands to thread network cables through these ports when installing the router. Unused ports are sealed with standard, environmental-proof plugs (3). See Chassis Cable Ports, page 22 for supported cable glands and plugs.
4	AC power connector	Connect the router AC power connector to a power source to power on the router. See AC Power Supply, page 26 .
5	10/100BASE-T Fast Ethernet (FE) port	Use this connector to connect the router to a 10/100BASE-T Ethernet network without requiring access to the router interior. This port is connected to the router ETH 2/5 port inside the router chassis. See Connecting the Ethernet Ports, page 104 .
6	System (SYS) LED	View the System LED to determine the overall operating and power status of the router. For detailed information about all the route LEDs, see Router LED Locations and States, page 181 .
7	Protective vent	The chassis vent relieves pressure buildup inside the router chassis. See Protective Vent, page 26 .

Interior Hardware Overview

This section illustrates the router front panel hardware features and includes a brief description of each feature. See [Hardware Features Detailed Description, page 22](#).

Figure 8 Interior Front Panel Hardware Features

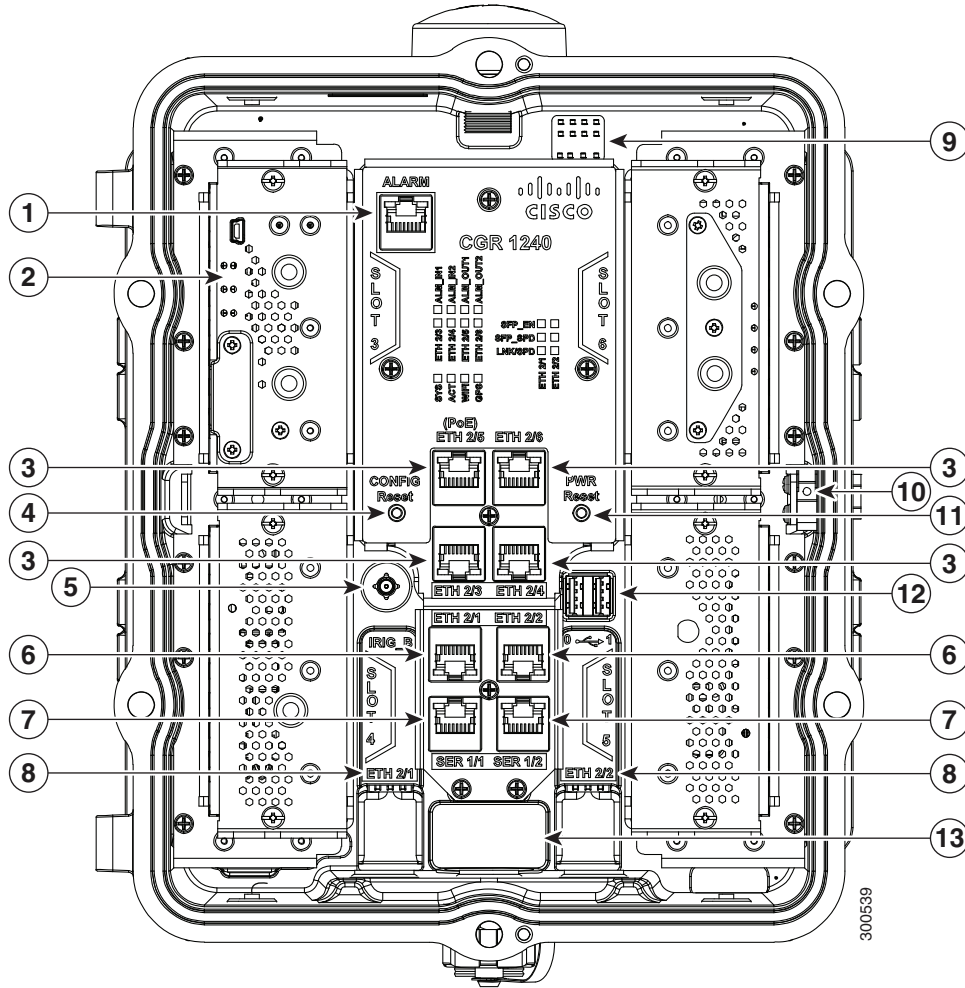

Note: In Table 9 on page 18, items indicated with Footnote 1 are currently not supported, and will be supported in a future software release.

Table 9 Interior (Front Panel) Features

Item	Label	Description
1	ALARM	Connect this alarm port to an alarm system to monitor system errors and events. See Alarm Port , page 27.
2	SLOT 3, SLOT4, SLOT 5, SLOT 6	Install Cisco Connected Grid modules in these four module slots. See Module Slots , page 29 and Module Installation Locations , page 117.
3	ETH 2/3, ETH 2/4, ETH 2/5, ETH 2/6	Make 10/100 Mbps Ethernet network connections using these four Fast Ethernet ports. See Fast Ethernet Ports , page 32.
4	CONFIG Reset	Press the CONFIG Reset button to reset the router to the default software configuration. See Reset Buttons , page 30.
5	IRIG_B (Not supported with IOS)	Connect the IRIG-B timing port (time source: router—see the GPS Module , page 41) to any device that requires precise time. See IRIG-B Timing Port , page 38.

Table 9 Interior (Front Panel) Features (continued)

Item	Label	Description
6	ETH 2/1, ETH 2/2	<p>Make 100/1000 Mbps Ethernet network connections using these two Gigabit Ethernet ports.</p> <p>See Gigabit Ethernet Ports, page 32.</p> <p>These physical ports share the ETH 2/1 and ETH 2/2 interfaces with the SFP ports, as described in the Combo Ports, page 35.</p>
7	SER 1/1, SER 1/2	<p>Connect the router to legacy devices, such as RTUs, using these two serial ports.</p> <p>See Serial Ports, page 36.</p>
8	ETH 2/1, ETH 2/2	<p>Install supported small form factor pluggable (SFP) modules in these two SFP ports.</p> <p>For supported SFPs, see Small Form-Factor Pluggable (SFP) Ports, page 33.</p> <p>These physical ports share the ETH 2/1 and ETH 2/2 interfaces with the 100/1000 Mbps ports, as described in Combo Ports, page 35.</p>
9	-	<p>The LEDs indicate alarm port status and connection status for Ethernet, WiFi, and GPS connections. The LED label is located in the center of the chassis (see Figure 8 on page 18).</p> <p>See Router LED Locations and States, page 181.</p>
10	-	<p>The door alarm switch triggers the router to generate a syslog event and send an SNMP alarm when the door is opened.</p> <p>See Opening and Closing the Router Chassis, page 75.</p>
11	PWR RESET	<p>Press the PWR RESET button to power cycle the router.</p> <p>See Reset Buttons, page 30.</p>
12	1  2	<p>Connect these USB ports to supported, external USB devices.</p> <p>See USB Ports, page 39.</p>
13	-	<p>Use the external Fast Ethernet connector to connect the router to an Ethernet network without requiring access to the router interior. This port is connected to one of the router internal FE ports.</p> <p>See Installing the Router, page 85.</p>

CGR1240 Filler Panels

When there is an empty slot in the chassis, it is important that it is covered by a blank plate, known as a Filler Panel. There are two types of Filler Panels on the CGR1240 represented by [Figure 9](#).

Figure 9 Filler Panels

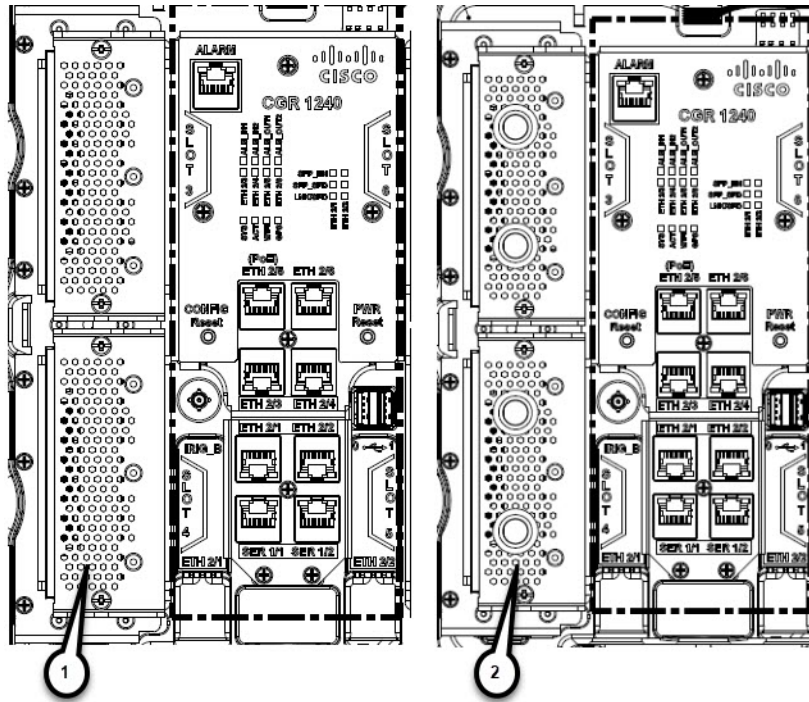

The original filler panel (1) is being phased out by the newer type (2) that has access holes for cables or wires. Graphics displayed in this guide show the original type.

Depending on your Product ID and slot, there will be a number of different hole populations possible. Refer to [Table 10](#)

Table 10 Filler Panel Hole Population

Chassis Product ID (PID)	Slot 3 Hole Population		Slot 4 Hole Population		Slot 5 Hole Population		Slot 6 Hole Population	
	Top Hole	Bottom Hole	Top Hole	Bottom Hole	Top Hole	Bottom Hole	Top Hole	Bottom Hole
CGR1240/K9=	To Antenna Position #4	To Antenna Position #3	To Antenna Position #5	Not Populated	To Antenna Position #8	Not Populated	To Antenna Position #1	To Antenna Position #2
CGR1240/K9-0CONN=	To Antenna Position #4	To Antenna Position #3	To Antenna Position #5	Not Populated	Not Populated	Not Populated	Not Populated	Not Populated
CGR1240/K9-1CONN=	To Antenna Position #4	To Antenna Position #3	To Antenna Position #5	Not Populated	Not Populated	Not Populated	Not Populated	Not Populated
CGR1240/K9-2CONN=	To Antenna Position #4	To Antenna Position #3	To Antenna Position #5	Not Populated	Not Populated	Not Populated	Not Populated	Not Populated

Refer to [Antenna Installation Location](#) within this guide for exact details.

Hardware Compliance

For a complete list of regulatory and compliance standards supported by the Cisco CGR 1240 Router, see the *Regulatory Compliance and Safety Information for the Cisco 1000 Series Routers* at:
<http://www.cisco.com/en/US/docs/routers/connectedgrid/cgr1000/rcsi/cgr1000.rsci.html>

Hardware Features Detailed Description

This section provides detailed information about all of the router hardware features, including descriptions, illustrations, specifications, and links to related information. This section is divided into two topics:

- [Router Hardware Exterior Features, page 22](#)
- [Router Hardware Interior Features, page 27](#)

Router Hardware Exterior Features

This section includes detailed information about the exterior hardware features and contains the following topics:

- [Chassis Enclosure, page 22](#)
- [Chassis Cable Ports, page 22](#)
- [Console Port, page 24](#)
- [SD Flash Memory Module, page 25](#)
- [10/100BASE-T Fast Ethernet Connector, page 26](#)
- [Protective Vent, page 26](#)
- [AC Power Supply, page 26](#)

Chassis Enclosure

The Cisco CGR 1240 Router industrial enclosure (see [Figure 1 on page 11](#)) meets Type 4X and IP67 standards and is designed for deployment in extreme weather. The enclosure can be painted to comply with aesthetic requirements.

Caution: Painting or otherwise modifying the router enclosure can affect the chassis operating temperature limitations.

UV testing has not been performed on the unit. The chassis has TGIC (triglycidyl isocyanurate) powder coating, so UV will not harm the device. The antennas are a polycarbonate blend and are UV stabilized. The exact life of the device is unknown. However, the device is designed for approximately 10-15 years of life, and there are devices in the field for 10 years already.

Specifications

Specification	Description
Dimensions	12 x 8 x 7.5 inches (30.5 x 20.3 x 19 cm)
Environmental	Type 4x compliant IP67 compliant
Operating temperature	-40 to +158° F (-40 to +70° C)

Additional Information

For router regulatory compliance information, see the *Regulatory Compliance and Safety Information for the Cisco 1000 Series Routers* on Cisco.com, at: www.cisco.com/go/cgr1000-docs

Chassis Cable Ports

The router chassis has the following cable ports for router network and power cables:

- **Door**—Two cable ports on the front door, shown in [Figure 2 on page 12](#), provide support for third party radio cabling. The router supports installation of a compatible radio, as described in [Installing External Non-Cisco Modules, page 173](#).
- **Chassis**—Seven cable ports on the router base, shown in [Figure 7 on page 17](#), provide support for router network cabling, as described in [Installing the Router, page 85](#).

Cable Glands

A cable gland (also known as a cable connector) is required to install cables in the chassis cable ports. Use a compatible cable gland to attach and secure the end of a cable to the router. The cable gland provides cable strain relief and seals the cable entry into the router chassis to prevent damage to the router interior.

Note: Cable Glands are ordered separately.

Figure 10 Cable Gland

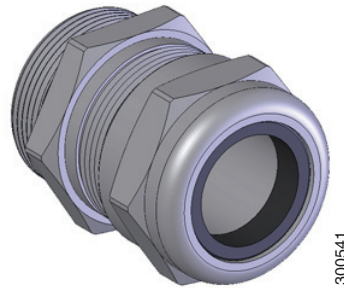

Table 11 Supported Cisco Cable Glands

Cisco Product ID	Description
CGR-IP67GLAND	Contains 1 gland and 1 tube of anti-seize compound

Specifications

Specification	Description
Size	PG 13 Cable diameters: 0.20–0.35 inches (5.08–8.89 mm)
Environmental	Liquid Tight Type 4x & IP67

Cable Port Seals

Unused router ports are sealed with a liquid-tight cover (PG13) to protect the router interior from environmental elements.

Caution: Do not install the router unless all unused chassis cable ports are sealed. Leaving chassis ports unsealed can damage the router.

Figure 11 Cable Port Seal

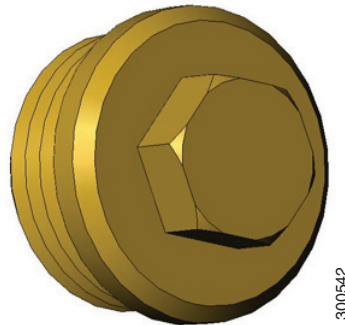

Console Port

The router features a single, asynchronous console port (see [Figure 4 on page 14](#) and [Figure 12 on page 25](#)) for connecting a console or PC directly to the router. To configure the router locally, using the command-line interface (CLI), you must establish a connection to the router with a terminal session.

Caution: This port does not support cable glands; the router interior is exposed to environmental elements while the port is in use. This port should be exposed only during active terminal sessions with the router and should never be left unattended when exposed.

Note: The router also supports wireless console connections with an integrated WiFi short-range access point. For more information see, [WiFi Short-Range Access Point, page 43](#).

Console Port Default Settings

The console port does not support hardware flow control. The default settings for the port are: 9600 baud, 8 data bits, no parity, and 1 stop bit.

Connecting to the Console Port

Your router kit includes a console cable with an RJ-45 connector on one end (for connecting to the router console port) and a DB-9 connector on the other end (for connecting to a PC or terminal).

Detailed information about connecting and using the console port is in [Installing the Router, page 85](#).

Figure 12 Console Port Detail

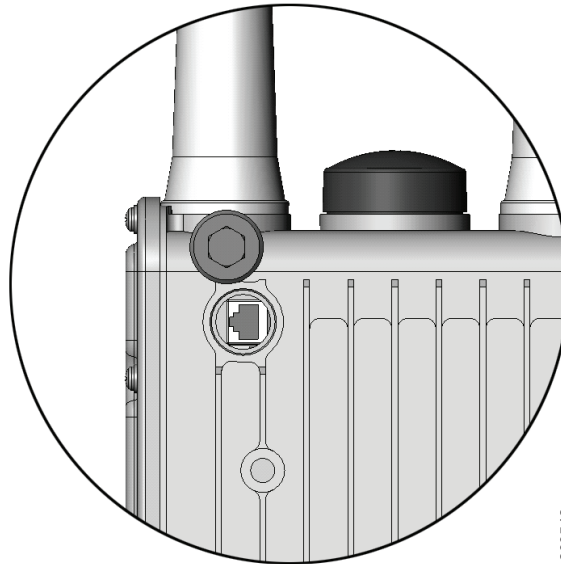

300543

Specifications

Specification	Description
Connector type	RJ-45
Transceiver	RS-232
Cable type	EIA RJ-45
Pinout	See Connector and Cable Specifications, page 195 .

SD Flash Memory Module

The router is shipped with one 2-GB Cisco Secure Digital (SD) flash memory module (see [Figure 5 on page 15](#) and [Figure 13 on page 26](#)), which stores router software and configurations. For detailed information on using the SD flash memory module with the router, see [Using the SD Flash Memory Module, page 133](#).

Figure 13 SD Flash Memory Slot Detail

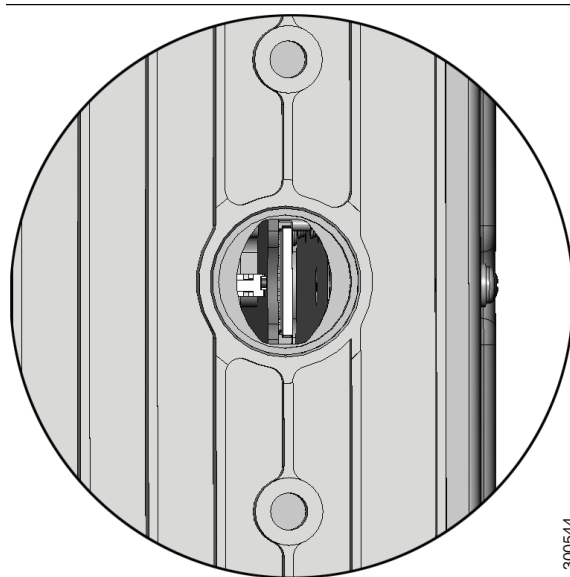

Caution: You must use only the Cisco SD card designed to support the router. Using an unsupported SD card can impact the router performance, especially in extreme environmental conditions.

10/100BASE-T Fast Ethernet Connector

The router has an external Fast Ethernet (FE) connector (see [Figure 7 on page 17](#)) that enables you to connect the router to an Ethernet hub or switch without opening the chassis.

The external connector is connected to the one of the fast Ethernet ports inside the router chassis. The internal port used depends on the router hardware configuration. If you are connecting the external Ethernet connector to an internal Ethernet port for the first time, Cisco recommends you connect it to the ETH 2/5 port. For more information, see [Fast Ethernet Ports, page 32](#).

Specifications

Specification	Description
Connector type	RJ-45, ODVA-compliant Copper Ethernet
Cable type for connection to internal FE port	Category 5 shielded, RJ-45 to RJ-45
Cable type for connection to Ethernet	Category 5 or higher shielded, Ethernet

Protective Vent

The protective vent on the router base (see [Figure 7 on page 17](#)) relieves pressure buildup inside the router chassis that can be caused by changing temperatures in the router installation environment. This prevents pressure from building up and damaging enclosure seals, exposing sensitive components to water. The vent also protects the router interior from dust, dirt, water, and other environmental elements.

AC Power Supply

The router has two power sources: an AC power supply and the battery backup units.

The AC power supply connector on the router base (see [Figure 7 on page 17](#)) is the connection to AC power. If AC power is no longer being supplied to the router, the battery backup units will continue to supply power to the router until AC power is restored. For details about how the battery backup units operate, see [Installing Battery Backup Units \(BBUs\), page 141](#).

Note: The AC power cable part number CGR-PWRCORD-NA or CGR-PWRCORD-EU must be ordered separately.

Specifications

Specification	Description
Input voltage	100-240 Vrms AC
Output	60W
Cooling	Convection, conduction
Operating temperature range	-40 to 158° F (-40 to 70° C), external ambient

Router Hardware Interior Features

This section includes detailed information about the interior hardware features illustrated in [Router Hardware Overview, page 10](#), and contains the following topics:

- [Alarm Port, page 27](#)
- [Module Slots, page 29](#)
- [Reset Buttons, page 30](#)
- [Fast Ethernet and Gigabit Ethernet Ports, page 31](#)
- [Small Form-Factor Pluggable \(SFP\) Ports, page 33](#)
- [Combo Ports, page 35](#)
- [Serial Ports, page 36](#)
- [IRIG-B Timing Port, page 38](#)
- [USB Ports, page 39](#)
- [Memory, page 41](#)
- [GPS Module, page 41](#)
- [WiFi Short-Range Access Point, page 43](#)

Alarm Port

Attach the alarm port inputs (see [Figure 14 on page 28](#)) to an alarm system to monitor external events that occur in the router's physical installation environment (for example, indicating that the router door has been opened). Attach the alarm port outputs to an alarm indicator such as a siren or light that is enabled by a relay dry contact open or closed circuit. The port supports two alarm inputs and two alarm outputs.

The alarm-trigger setting determines when an alarm is sent to the attached alarm system.

Figure 14 Router Alarm Port

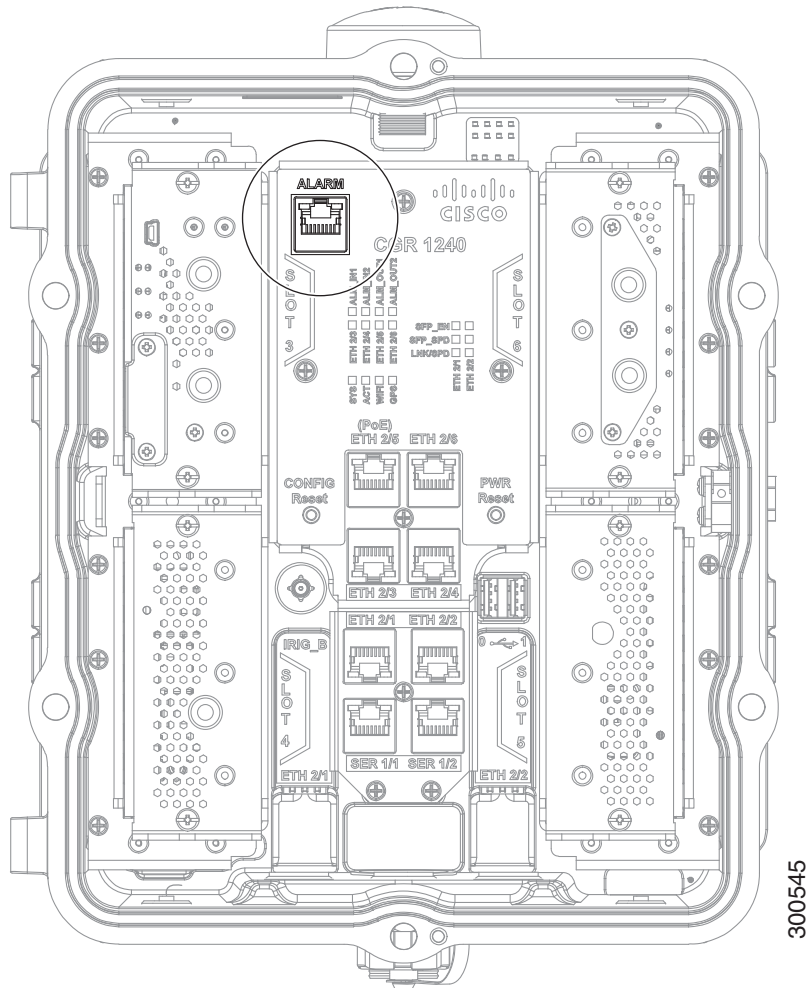

Input Alarm Trigger Settings

- **Open**—The **open** setting indicates that the normal (non-alarm state) router operating condition has an electrical current passing through the alarm circuits (DRY contact closed). If this electrical current is no longer detected (DRY contact open), an alarm is generated.
- **Closed**—The **closed** setting indicates that the normal (non-alarm state) router operating condition is that no electrical current is passing through the alarm circuits (DRY contact open). If an electrical current is detected (DRY contact closed), an alarm is generated.

Output Alarm Trigger Settings

- **Normally Open (NO)**—This setting depends on the pinout of the cable that is connected to the alarm port. See [Connector and Cable Specifications, page 195](#).
- **Normally Closed (NC)**—This setting depends on the pinout of the cable that is connected to the alarm port. See [Connector and Cable Specifications, page 195](#).

If interfaces fail or other non-fatal errors occur, the alarm port does not respond. Continue to use SNMP to manage these types of errors.

Note: Due to the RJ-50 pin spacing, the alarm port does not support AC signaling.

Specifications

Specification	Description
Connector type	RJ-50
Alarm input	8 volts @ 1 mA
Alarm output	30 volts @ 1 A

Module Slots

The router has four module slots to support installation of up to four compatible Cisco Connected Grid modules, for additional router WAN and NAN interfaces. Modules should be installed in the slots according to the module slot numbers shown in [Figure 15 on page 30](#) and [Module Installation Locations, page 117](#). For more information about installing modules, see the corresponding installation and configuration guide for each module at: www.cisco.com/go/cg-modules

Module Numbering

The system software uses a module numbering scheme to identify router components, including the modules. Some system software commands refer to module numbers. The numbers refer to the following router hardware components:

- The router supervisor engine (located on the CPU motherboard) is referred to as module 1.
- The router's integrated Ethernet switch module, which has four Fast Ethernet ports and two Gigabit Ethernet ports, is referred to as module 2.
- Modules are installed in the router module slots numbered 3–6 (see [Figure 15 on page 30](#) for module slot numbering). For information on the module (3G, WPAN, WiMAX) to slot allocation, see [Module Installation Locations, page 117](#).

Figure 15 Router Module Slot Numbering

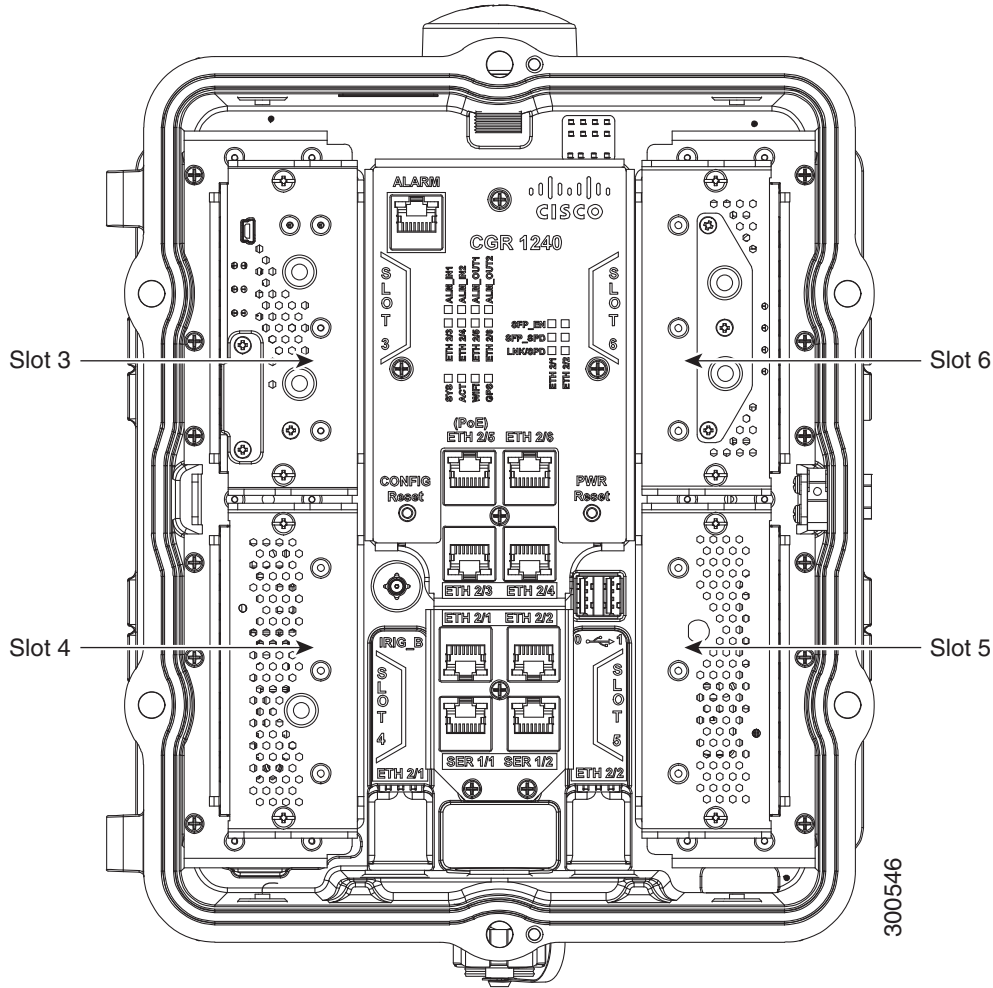

Reset Buttons

Use these reset buttons (see [Figure 16 on page 31](#)) as follows:

Caution: When you use the CONFIG Reset button to restore the router to the factory default software configuration, the current software configuration is permanently deleted from the router.

Note: The CONFIG Reset button operates differently whether the device is running IOS or CGOS. Both modes are described here, see the Software Configuration Guide for more details.

- **CONFIG Reset– IOS** – Press the CONFIG Reset button for at least 10 seconds to erase the startup-config, and power cycle the router. Power cycling the router turns the router off, then immediately back on. The router will temporarily stop operating on the network during the power cycle, then resume operating when the power cycle process is complete. If the CONFIG Reset button is pressed for more than 5 seconds (but less than 10 seconds), the router will only be power-cycled.
 - If the CONFIG Reset button is pressed for more than 5 seconds (but less than 10 seconds), and the config file express-setup-config exists on the flash: partition, the router configuration will be rolled back to that express-setup-config and reloaded.
 - If the CONFIG Reset button is pressed for more than 5 seconds (but less than 10 seconds), and the config file express-setup-config file does NOT exist on the flash: partition, the router will simply be power-cycled.

- **CONFIG Reset– CGOS**– Press the CONFIG Reset button for at least 5 seconds to return the router software configuration to the factory default, and power cycle the router. Power cycling the router turns the router off, then immediately back on. The router will temporarily stop operating on the network during the power cycle, then resume operating when the power cycle process is complete.
- **PWR RESET**–Press the PWR RESET button for at least 5 seconds to power cycle the router. Power cycling the router turns the router off, then immediately back on. The router will temporarily stop operating on the network during the power cycle, then resume operating when power cycle process is complete.

Figure 16 Router Reset Buttons

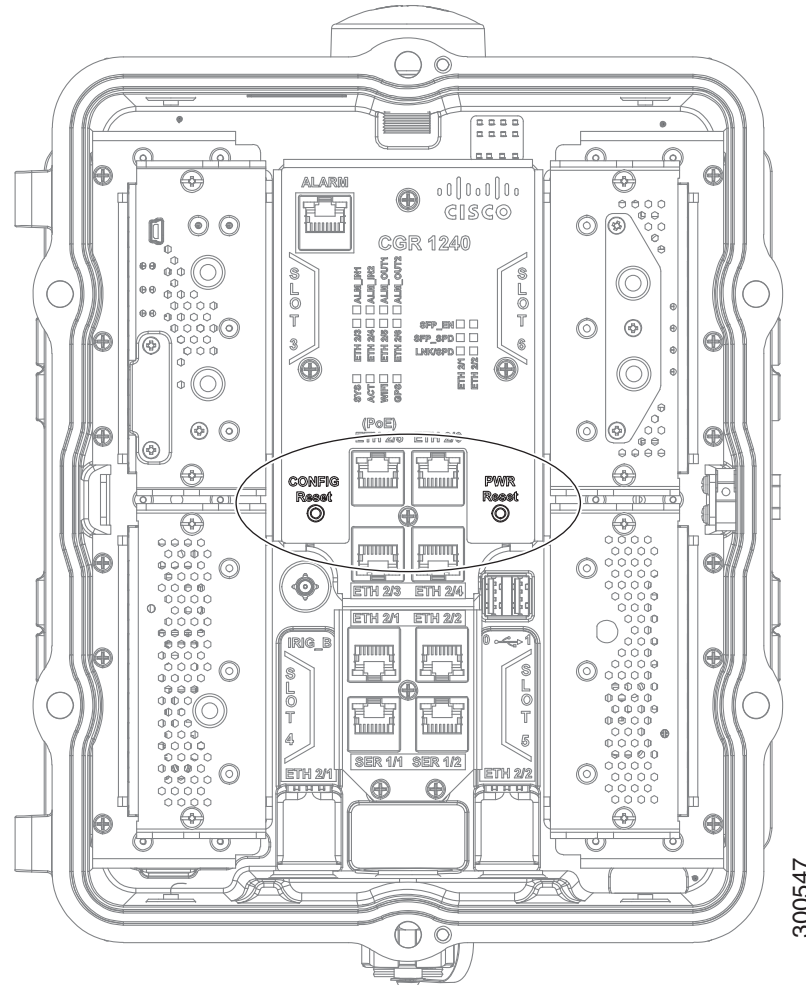

Fast Ethernet and Gigabit Ethernet Ports

The CGR 1240 router has two types of Ethernet port: fast Ethernet and Gigabit Ethernet port. These are described in the following sections:

- [Fast Ethernet Ports, page 32](#)
- [Gigabit Ethernet Ports, page 32](#)
- [Fast Ethernet and Gigabit Ethernet Port Specifications, page 33](#)

Fast Ethernet Ports

The router features four fast Ethernet (FE) ports that can be connected to LAN devices such as Intelligent Electronic Devices (IEDs), sensors, meters, protective relays, and reclosers. [Table 12 on page 32](#) describes how the Fast Ethernet ports are labeled on the router and referred to in software. The ports are shown in [Figure 17 on page 32](#).

Figure 17 Cisco CGR 1240 Router Fast Ethernet and Gigabit Ethernet Ports

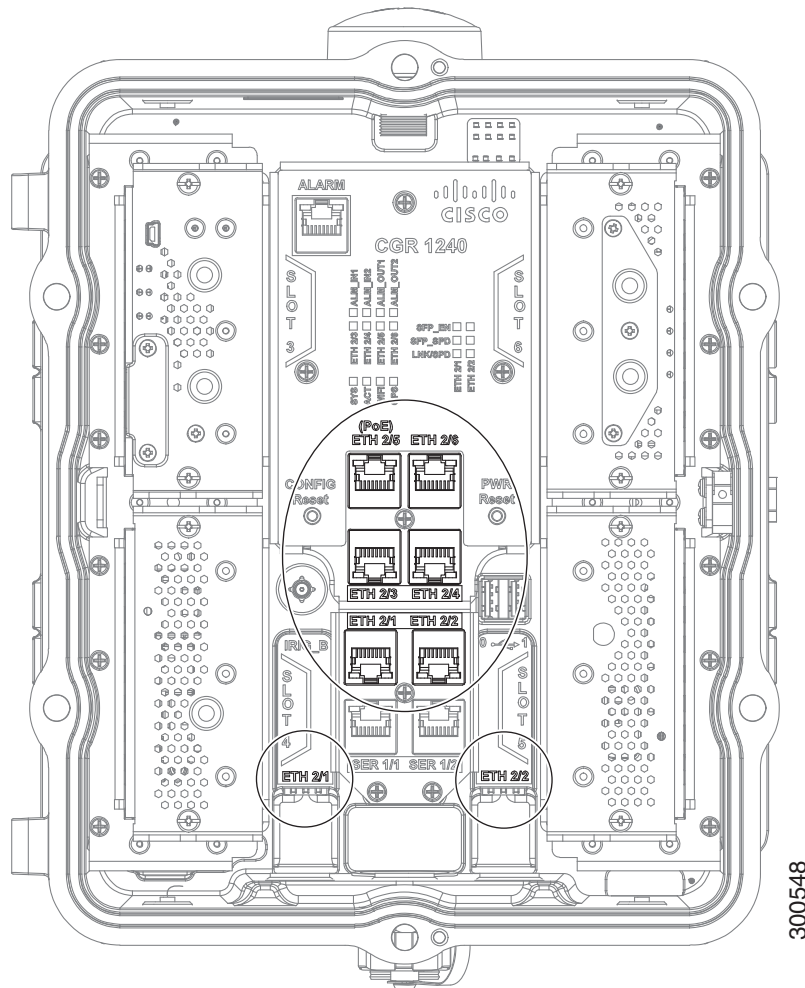

Table 12 CGR 1240 Fast Ethernet Port Naming

CGR 1240 Router Label	CG-OS Software Port Name	Cisco IOS Software Port Name
ETH 2/3	FE 2/3	FE 2/3
ETH 2/4	FE 2/4	FE 2/4
ETH 2/5 (PoE ¹)	FE 2/5	FE 2/5
ETH 2/6	FE 2/6	FE 2/6

¹ PoE = Power over Ethernet (provides up to 15.4 W per port).

Gigabit Ethernet Ports

The router features two Gigabit Ethernet (GE) ports that can be used to enable WAN connectivity to a primary substation or a control center. The ports are shown in [Figure 19 on page 36](#).

Table 13 on page 33 describes how the GE ports are labeled on the router and referred to in software.

Table 13 CGR 1240 Gigabit Ethernet Port Naming

CGR 1240 Router Label	Cisco CG-OS Software Port Name	Cisco IOS Software Port Name
ETH 2/1	GE 2/1	GE 2/1
ETH 2/2	GE 2/2	GE 2/2

Note: Interfaces ETH 2/1 and ETH 2/2 are also used by the small form-factor pluggable (SFP) ports (see [Small Form-Factor Pluggable \(SFP\) Ports, page 33](#)). For more information about how these ports are used together, see [Combo Ports, page 35](#).

The GE ports automatically detect the type of any connected cable (fiber or copper) and then switch to the corresponding mode (fiber or copper). When both cables types are connected to the router, the first cable that establishes a link is enabled.

Fast Ethernet and Gigabit Ethernet Port Specifications

Table 14 Fast Ethernet and Gigabit Ethernet Port Specification Overview

Specification	Description
Ethernet Standard	IEEE 802.3.
Connector type	RJ-45
Interface speed	10BASE-T, 100BASE-TX, 1000-BASE-TX
Pinouts	See Connector and Cable Specifications, page 195 .

Table 15 Fast Ethernet and Gigabit Ethernet Port Specification Detail

Speed	Descriptions	Cable Type	Distance
1000BASE-TX	1000 Mbps full-duplex transmission	Category 5 or better	328 feet (100 meters)
100BASE-TX	100 Mbps full-duplex transmission	Category 5 or better shielded twisted-pair (STP) cable	328 feet (100 meters)
10BASE-T	10 Mbps full-duplex transmission	Category 5 or better shielded twisted-pair (STP) cable	328 feet (100 meters)

Small Form-Factor Pluggable (SFP) Ports

The router features two fiber optical SFP ports that support optional Cisco rugged SFP modules for Gigabit Ethernet WAN connectivity to a primary substation or control center.

Note: The SFPs do not come with a Cable Gland kit, Those must be ordered separately.

The ports are labeled as follows (see [Figure 18 on page 34](#)):

- ETH 2/1
- ETH 2/2

Note: Interfaces ETH 2/1 and ETH 2/2 are also used by the Gigabit Ethernet ports (see [Gigabit Ethernet Ports, page 32](#)). For more information about how these ports are used together, see [Combo Ports, page 35](#).

- Hot Swapping SFP Modules, page 34
- Supported SFPs, page 34
- Specifications, page 35

Figure 18 Router SFP Ports

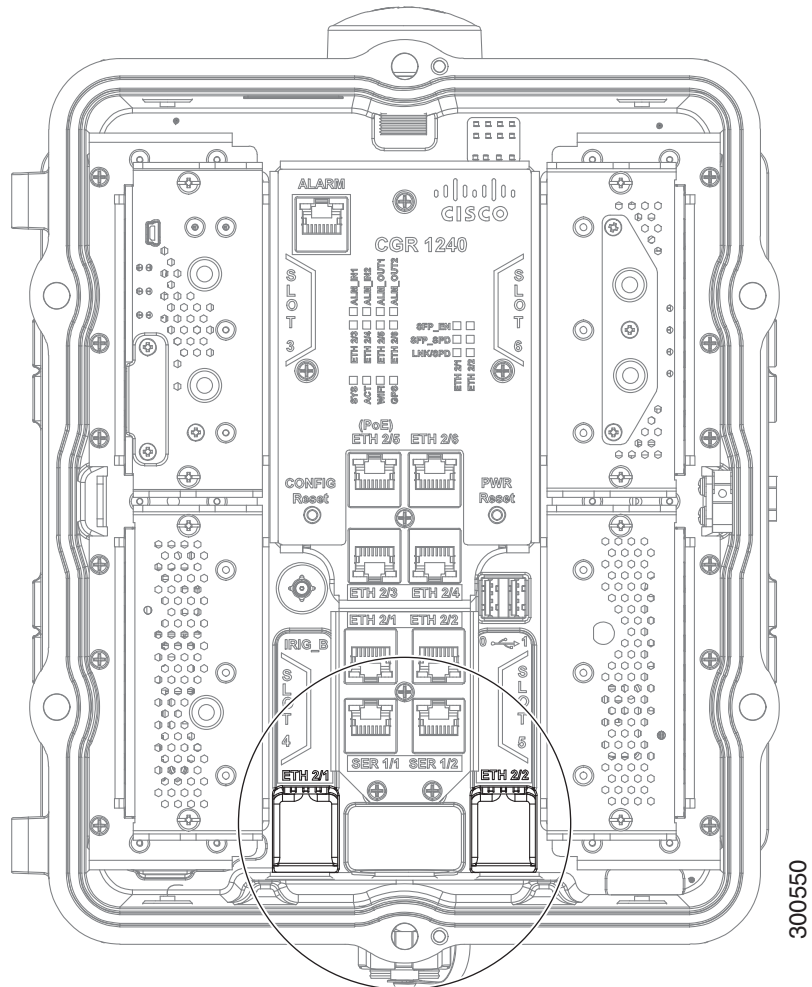

Hot Swapping SFP Modules

The SFP modules can be installed or removed while the router is on and operating normally.

Supported SFPs

Table 16 on page 35 lists the supported SFP modules.

Note: See the *Cisco 1000 Series Connected Grid Routers Release Notes* for the most recent information about supported hardware and software.

Table 16 Supported SFP Modules

Cisco Product ID	Description
GLC-BX-D	1000BASE-BX10-D downstream bidirectional single fiber; with DOM
GLC-BX-U	1000BASE-BX10-U upstream bidirectional single fiber; with DOM
GLC-SX-MM-RGD	1000BASE-SX short wavelength; rugged
GLC-LX-SM-RGD	1000BASE-LX/LH long wavelength; rugged
GLC-ZX-SM-RGD	1000BASE-ZX extended distance; rugged
GLC-FE-100FX-RGD	100BASE-FX SFP; rugged
GLC-FE-100LX-RGD	100BASE-LX10 SFP; rugged

Specifications

Specification	Description
Connector type	LC
Optical Interface	100Base-FX, LX; 1000Base-SX, LX, ZX
Coding Scheme	SFP modules: <ul style="list-style-type: none">■ 1000 Mbps 8B/10B coding■ 100 Mbps 4B/5B coding
Pinouts	See Connector and Cable Specifications, page 195 .

Combo Ports

The combo ports are two Gigabit Ethernet ports and two SFP ports on the router that are labeled identically. [Figure 19 on page 36](#) shows the ports.

The GE and SFP ports share the same physical ports or connections and are labeled identically on the router (ETH 2/1, ETH 2/2) and in the software (GE 2/1, GE 2/2). [Table 17 on page 36](#) describes the port naming on the router and in software.

The Gigabit Ethernet ports support copper GE connections and the SFP modules support fiber optic GE connections. Only one connection on each interface (ETH 2/1 and ETH 2/2) can be in use at any time.

These ports automatically detect the type of any connected cable (fiber or copper) and then switch to the corresponding mode (fiber or copper).

Note: If connections are made to both interfaces of the same name (ETH 2/1 or ETH 2/2), only the first connection that establishes a link is enabled.

Figure 19 GE Ports and SFP Ports Share Interfaces ETH 2/1 and ETH 2/2

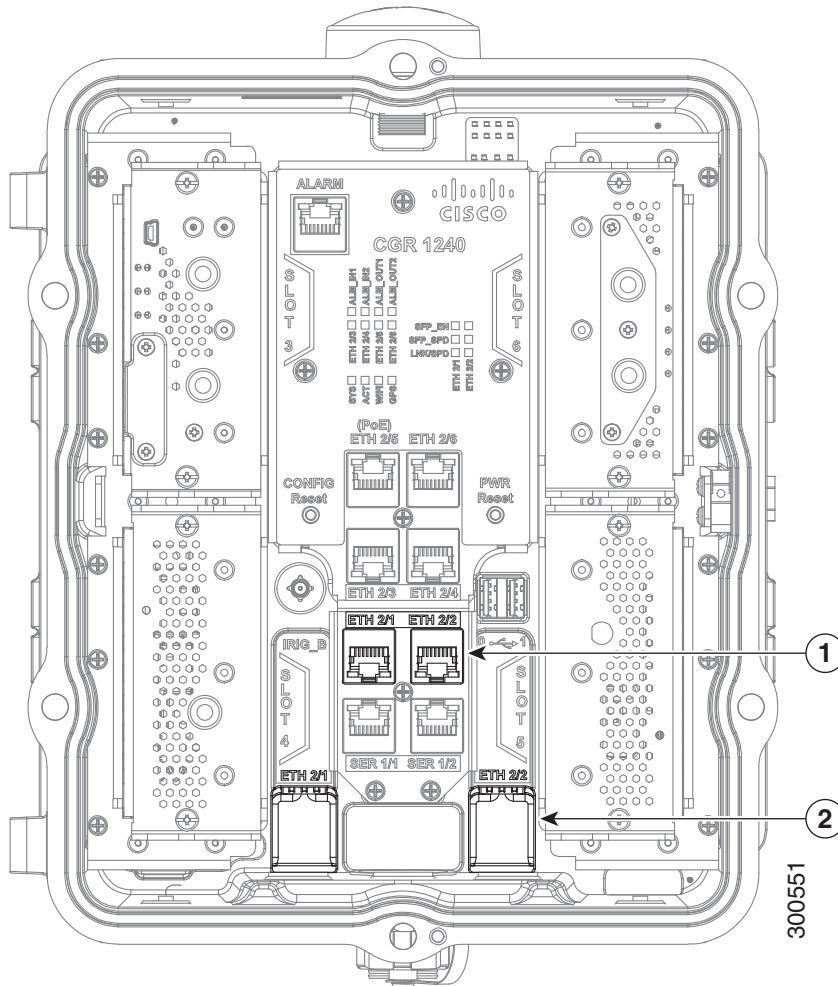

Items	Description	Gigabit Ethernet Connection Type
1	Gigabit Ethernet ports	Copper
2	SFP module ports	Fiber optic

Table 17 Cisco CGR 1240 Gigabit Ethernet and SFP Port Naming

CGR 1240 Router Label	Cisco CG-OS Software Port Name	Cisco IOS Software Port Name
ETH 2/1	GE 2/1	GE 2/1
ETH 2/2	GE 2/2	GE 2/2

Serial Ports

The router has two serial ports for connection to legacy devices, such as remote terminal units (RTUs). These ports support the following modes (selected with system software commands):

- RS232
- RS485

Note: When running IOS, these two serial ports are referred to as Async 1/1 and Async 1/2.

The ports are labeled as follows (Figure 20 on page 37):

- SER 1/1
- SER 1/2

Figure 20 Router Serial Ports

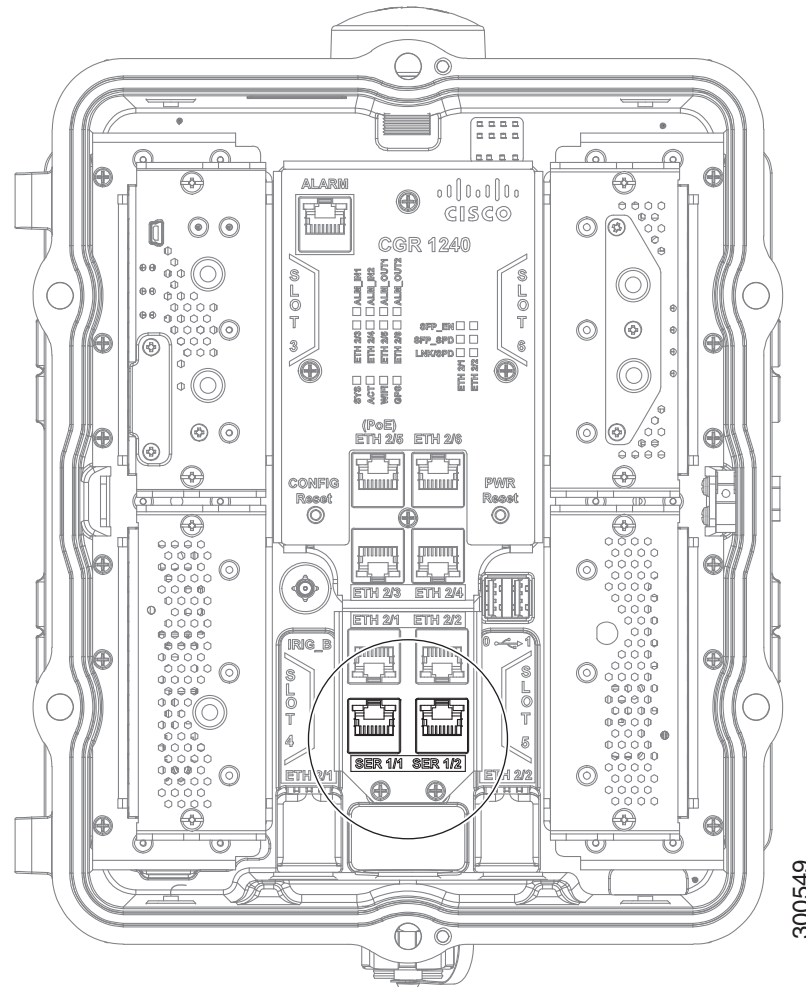

300549

Before you connect a device to a serial port, you need to know the following:

- Type of device, data terminal equipment (DTE), or data communications equipment (DCE), you are connecting to the synchronous serial interface
- Signaling standard required by the device
- Serial ports can be configured as DTE or DCE, depending on the serial cable used

Serial Port Cables

You can order a Cisco RJ-45 shielded serial-transition cable that has the appropriate connector for the standard you specify. The documentation for the device should indicate the standard used for that device. The router end of the shielded serial transition cable has a DB-25 connector, which connects to the DB-25 port on a serial grid router WAN interface card. The other end of the serial transition cable is available with a connector appropriate for the standard you specify. The synchronous serial port can be configured as DTE or DCE, depending on the attached cable.

Specifications

Table 18 Serial Signal Transmission Speeds and Distances

Rate (bps)	Distance for EIA/TIA-232	
	Feet	Meters
2400	200	60
4800	100	30
9600	50	15
19200	25	7.6
38400	12	3.7
56000	8.6	2.6
1544000 (T1)	–	–

Specification	RS232	RS485
Connector type	RJ-45	RJ-45
Cable	See Serial Port Cables, page 37	See Serial Port Cables, page 37
Signaling	Single-ended	Differential
Max. drivers	1	32
Max. receivers	1	256
Operating mode	Full duplex	Half duplex Full duplex
Network topology	Point-to-point	Multipoint Note: Multipoint is not enabled by software.
Max. distance (standard)	15 m	1200 m
Max speed (at 12 m/1200 m)	20 Kbps/1 Kbps	35 Mbms/100 Kbps
Pinouts	See Connector and Cable Specifications, page 195 .	

IRIG-B Timing Port

The router features a single IRIG-B timing port (see [Figure 21 on page 39](#)), which provides serial formatted time codes to an optional connected device. IRIG-B output provides standard time codes so timing devices can correlate time information with network devices. The router-integrated GPS provides the time information that is provided by this interface.

Note: The IRIG-B timing port supports timing output only.

Note: There is no IOS support for the IRIG-B Timing Port.

Figure 21 Router IRIG-B Timing Port

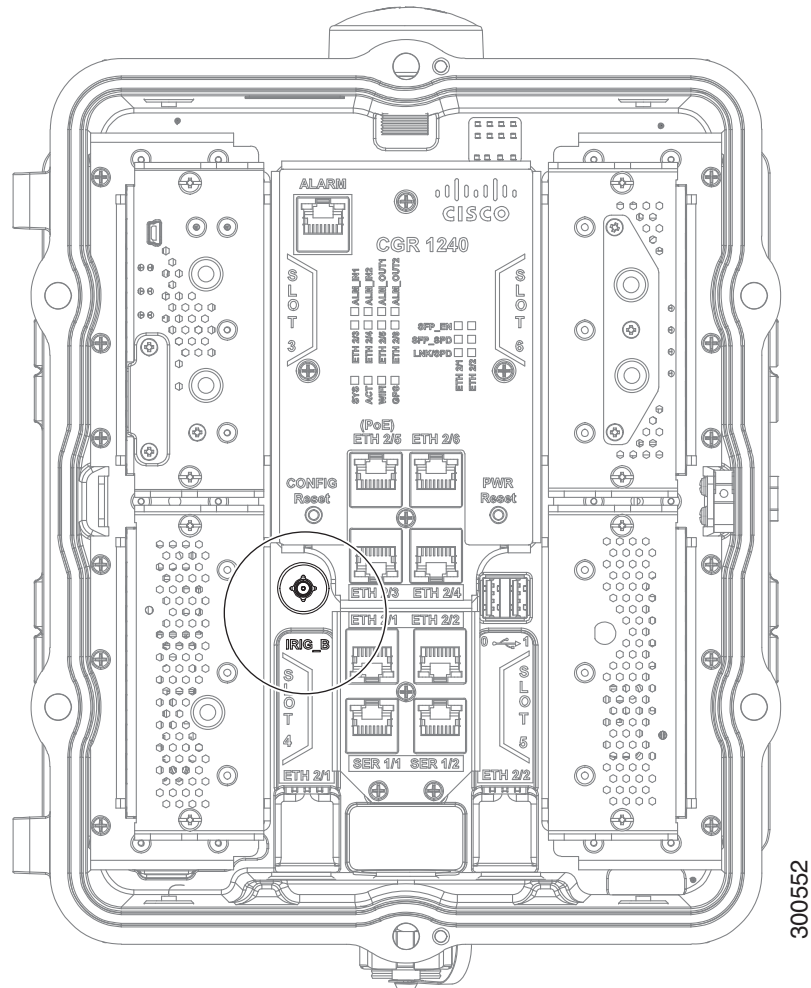

300552

Table 19 Supported IRIG Serial Time Code Formats

Format	Modulations	Carrier Frequency	Code Expression	Interface
B000	DC Level Shift (DCLS) pulse-width coded	None	BCD time of year, CF and SBS	RS232/RS485
B120	Amplitude Modulation (AM)	1kHz sine wave	BCD time of year, CF and SBS	50 Ohms BNC

Specifications

Specification	Description
Connector type	SMB coaxial RF
Supported Code Formats	IRIG-B000 and B120

USB Ports

The router features two standard USB 2.0 ports for connecting and powering optional USB peripheral devices. These ports also support USB devices that are powered by an external source, such as an AC adapter or batteries.

These ports are labeled as follows (see [Figure 22 on page 40](#)):



The USB ports operate at the following speeds:

- 1 Mbps
- 12 Mbps
- 480 Mbps

Note: Supported by the Guest Operating System on the IOx bundle.

Figure 22 Router USB Ports

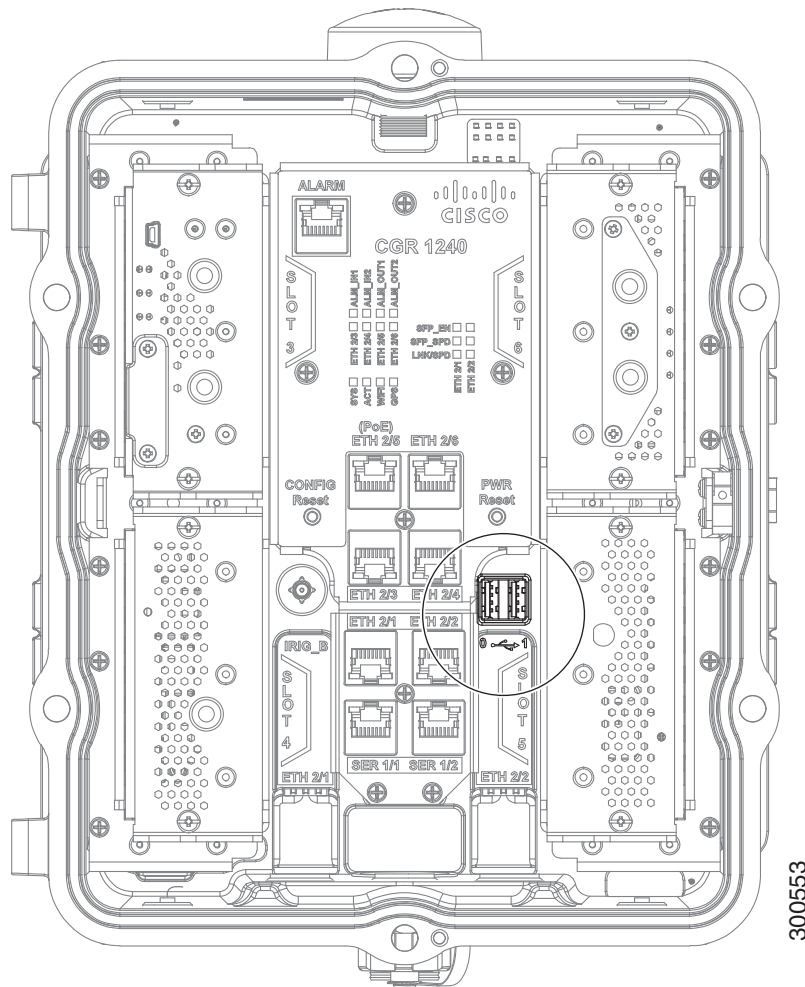

300553

Connection Considerations

- Depending on the USB devices you connect to these ports, you might require a USB extension cable to connected devices to these ports.

- To prevent USB devices from being stolen or accidentally removed, secure any connected USB device with a locking mechanism.

Specifications

Specification	Description
USB Port Type	Type A
USB Device Types Supported	USB 1.1, USB 2.0
Power Output	2.5W (+5V +/-5% @ 500mA) per port

Memory

SD Flash Memory

The router supports a single SD Flash Memory module (SD card), which can be accessed from the router exterior. See [SD Flash Memory Module, page 25](#) and [Using the SD Flash Memory Module, page 133](#).

SDRAM

The router features 1 GB of double data rate (DDR) SDRAM.

Boot Flash

The router features 16 MB of boot flash memory, consisting of two 8 MB Serial Peripheral Interface (SPI) flash devices.

DC Power for External Devices

The router features a 4-pin Micro-Fit 3.0 power connector to support a compatible external device, such as an optional non-Cisco wireless module installed on the router exterior.

More Information

- For detailed instructions on how to install a non-Cisco module and connect to this DC power connector, see [Installing External Non-Cisco Modules, page 173](#).
- Pinouts for the Molex Micro-Fit 3.0 connector are in [Connector and Cable Specifications, page 195](#).

Specifications

Specification	Description
Voltage	12 VDC +/-5%
Maximum Power	12 W (continuous)
DC Power Connector	Molex Micro-Fit 3.0 (4-pin receptacle)

GPS Module

The router has an internal Global Positioning System (GPS) module, which receives precise time and location information from the GPS network, and provides this information to the system software. If the router is running IOS, GPS can also be a source clock for the IOS NTP server.

This section has information on:

- [GPS LED, page 42](#)

- [GPS Specifications, page 42](#)
- [Using the CLI to Display GPS Current Time and Location for a Cisco Router, page 42](#)

GPS LED

You can view the GPS LED to determine the GPS state and whether or not it is successfully connected to a GPS satellite. For information on the GPS LED, see [Router LED Locations and States, page 181](#).

GPS Specifications

[Table 20 on page 42](#) shows the GPS specifications for the Cisco Connected Grid 1000 Series Routers.

Table 20 GPS Specifications for Cisco Connected Grid 1000 Series Routers

Specification	Description
Channels	12
Tracking sensitivity	-160 dBm
Acquisition sensitivity	-148 dBm
Fast TTFF (Cold start)	38 seconds
Error correction	Space Based Augmentation Systems (SBAS)

Using the CLI to Display GPS Current Time and Location for a Cisco Router

- [Displaying GPS Current Time and Location for a Cisco CG-OS Router, page 42](#)
- [Displaying GPS Current Time and Location for a Cisco IOS Router, page 42](#)

Displaying GPS Current Time and Location for a Cisco CG-OS Router

Use the commands in this section to see the GPS current time and location.

Use the **show gps time** command to display the current GPS time:

```
CGR1240# show gps time
8:46:9.923 UTC Fri Oct 10 2013
```

Use the **show gps location** command to display the GPS latitude and longitude:

```
CGR1240# show gps location
Latitude: 37.4090637
Longitude -121.9523598
```

Displaying GPS Current Time and Location for a Cisco IOS Router

Use the commands in this section to see the GPS current time and location.

Use the **show platform gps time** command to display the current GPS time:

```
CGR1240# show platform gps time
0:55:26.588 UTC Tue May 14 2013
```

Use the **show platform gps location** command to display the GPS latitude and longitude:

```
CGR1000# show platform gps location
Latitude: 37.4184227
Longitude -121.9190216
```

WiFi Short-Range Access Point

The router features an integrated, short-range WiFi access point to support a wireless console connection to the router. Generally, the router is installed on a pole above the ground, which makes a wired console connection impractical during router operation.

The WiFi connection is available only when the system software is operating. If the system software is not operating, you cannot use the WiFi connection to connect to or administer the router.

When running IOS, Wi-Fi can be used as an access point for up to 5 devices, but also as a layer-3 interface.

WiFi Hardware

The CGR 1240 router is equipped with an 802.11b/g/n 2.4GHz radio that works as the access point to provide WiFi connectivity to the router. The WiFi hardware is a Broadcom BCM4325 chipset based radio with an external WiFi antenna.

WiFi Default Settings

The default WiFi interface identity settings for the Cisco CG-OS and Cisco IOS operating systems are detailed in [Table 21 on page 43](#).

Note: The CGR 1240 WiFi interface is assigned to module 2 and cannot be changed.

Table 21 Default WiFi Interface Identity Settings

Cisco Operating System	Interface Identity
Cisco CG-OS	wifi 2/1
Cisco IOS	dot11Radio 2/1

For more information on the WiFi configuration and setting it, see the *Cisco 1000 Series Connected Grid Routers WiFi Software Configuration Guide* on Cisco.com, at: www.cisco.com/go/cgr1000-docs.

Related Commands

- [Displaying WiFi Configuration Information for a Cisco CG-OS Router, page 43](#)
- [Displaying WiFi Configuration Information for a Cisco IOS Router, page 43](#)

Displaying WiFi Configuration Information for a Cisco CG-OS Router

Note: For a CGR 1240 router using the Cisco CG-OS operating system, the WiFi interface is identified as ‘wimax 2/1’.

To display WiFi configuration information, enter any or all of the following commands in privileged EXEC or user EXEC mode:

- **show interface wifi slot/port [associations | brief | description | statistics]**—Displays the status of the interface as up or down, the five second input and output rate and the number of input and output packets. Additionally, the Cisco CG-OS router displays hardware details such as radio type (802.11N, 2.4 GHz radio), MAC address and MTU setting.
- **show controller wifi slot/port**—Displays serial number, software version, and configured frequency and power settings

For detailed information about these commands, see “Configuring the WiFi Interface” in the *Cisco 1000 Series Connected Grid Routers WiFi Software Configuration Guide*, at www.cisco.com/go/cgr1000-docs.

Displaying WiFi Configuration Information for a Cisco IOS Router

Note: For a CGR 1240 router using the Cisco IOS operating system, the WiFi interface is identified as ‘Dot11Radio 2/1’.

To display WiFi configuration information, enter any or all of the following commands in privileged EXEC or user EXEC mode:

- **show interface dot11Radio 2/1**—Displays the status of the interface as up or down, the five second input and output rate and the number of input and output packets. Also displays hardware details such as radio type (802.11N, 2.4 GHz radio), MAC address and MTU setting.
- **show controller dot11Radio 2/1**—Displays the serial number, software version, and configured frequency and power settings.

For detailed information on how to use these commands, see the *Cisco 1000 Series Connected Grid Routers WiFi Software Configuration Guide* on Cisco.com, at: www.cisco.com/go/cgr1000-docs.

Real-Time Clock (RTC)

The router features an integrated real-time clock (RTC) with battery backup that supplies the system software with accurate date and time information.

Temperature Sensor

The router hardware features an internal temperature sensor used by the router software to monitor the system operating temperature. The router can be configured to generate alerts when the temperature falls outside of a user-defined temperature range. The router can also be configured to store historical temperature data.

For more information about monitoring and storing router temperature data, see the router configuration guide on Cisco.com at: www.cisco.com/go/cgr1000-docs



Mounting the Router

This section describes the safety information, equipment, and procedures required to mount the Cisco 1240 Connected Grid Router (CGR 1240 or router) on a vertical pole or streetlight.

These topics are discussed:

- [Mounting Kits Overview, page 45](#)
- [General Safety Information for Mounting, page 46](#)
- [Contents of the Mounting Kits, page 46](#)
- [Materials and Tools You Supply, page 50](#)
- [Mounting Instructions, page 50](#)
- [Simple Mounting Bracket for Pole Mounting of CGR1240, page 59](#)
- [Grounding Instructions, page 70](#)
- [Bracket Dimensions, page 72](#)

Mounting Kits Overview

You will need some or all of the kits described in this section to install the router on a pole. Your installation environment and requirements determine the kits you need.

For a detailed description of each kit, see [Contents of the Mounting Kits, page 46](#).

Cisco Product ID (PID)	Name	Description
-	Mounting Bracket Kit, page 47	Use this kit if your installation requires a Cisco mounting bracket to mount the router. This kit is included within the router accessory kit, and is used with the pole kit and includes the hardware required to attach the mounting bracket to the mounting plate.
CGR-PMK1000	Pole Mount Kit, page 46	This kit is required for all pole or streetlight installations and includes a mounting plate and the hardware required to attach the mounting plate to a pole.
CGR-PMK-BAND	Band Strap Kit, page 48	This kit includes two steel straps for mounting the router on poles larger than 4.5 inches (11.4 cm) in diameter. This kit is used together with the Pole Mount Kit, page 46 . A BAND-IT Tool is required to install the steel straps on a pole.
AIR-BAND-INST-TL=	Strap Tool Kit, page 49	This kit includes a BAND-IT tool that is required when using steel straps to install the router on poles larger than 4.5 inches (11.4 cm) in diameter.

General Safety Information for Mounting

Read the safety warnings in this section and in [Installation Safety and Site Preparation, page 3](#).

One person is required to properly and safely mount the router.

Caution: All mounting methods at any location are subject to the acceptance of local jurisdiction.

Caution: The mounting surface, attaching screws, and optional wall anchors must be able to support a 50 pound (22.7 kg) static weight.

Caution: Personnel mounting the router must understand grounding methods.

Warning: Do not locate the antenna near overhead power lines or other electric light or power circuits, or where it can come into contact with such circuits. When installing the antenna, take extreme care not to come into contact with such circuits, as they may cause serious injury or death. For proper installation and grounding of the antenna, please refer to national and local codes (for example, U.S.:NFPA 70, National Electrical Code, Article 810, Canada: Canadian Electrical Code, Section 54). Statement 1052

Contents of the Mounting Kits

This section describes the contents of the mounting kits available for the router and when you should use each kit.

Pole Mount Kit

Use the Cisco pole mount kit to install the mounting plate on any pole or streetlight. The kit supports poles that meet the following criteria:

- **Size**—2 to 16 inch diameter poles
- **Material**—Metal, wood, or fiberglass poles

Figure 23 Pole Mount Kit Contents

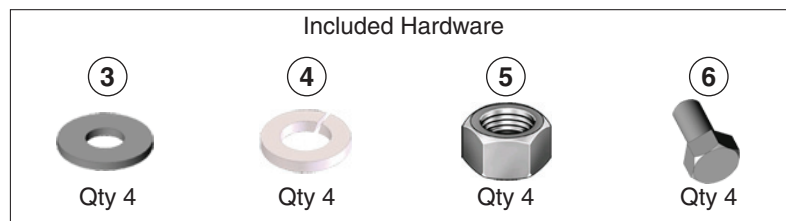
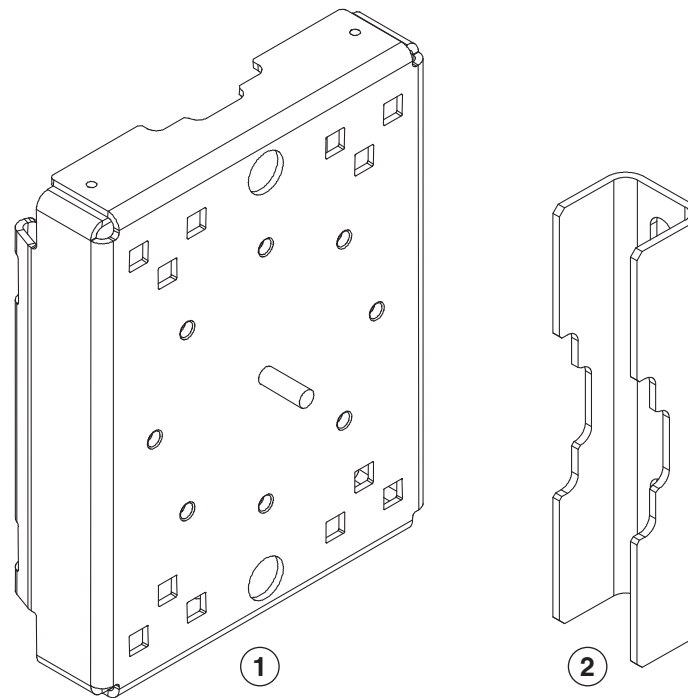

Item	Name	Qty.	Description
1	Mounting plate	1	Install mounting plate on pole. Mounting bracket attaches to mounting plate.
2	Clamp brackets	2	Use the clamp brackets to install the mounting plate on a pole.
Included Hardware			
3	Washer (3/8 inch)	4	Use the included hardware to attach the mounting plate to the pole, as described in Install the Mounting Plate onto a Pole, page 50 .
4	Split lock washer (3/8 inch)	4	
5	Nut (3/8-16)	4	
6	Carriage bolt (3/8-16 x 7 inches)	4	

Mounting Bracket Kit

Use the mounting bracket kit if you require a Cisco mounting bracket. The mounting bracket attaches to the mounting plate, and then the router is installed on the mounting bracket.

Note: You can optionally use any compatible mounting bracket with the Cisco pole mount kit. Check with your authorized Cisco reseller for compatible mounting brackets. See [Pole Mount Kit, page 46](#)

Figure 24 Mounting Bracket Kit Contents—Required Parts

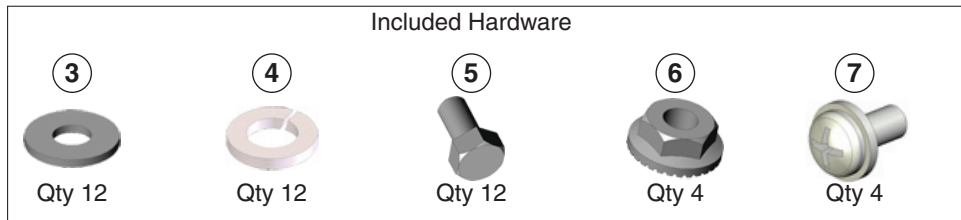
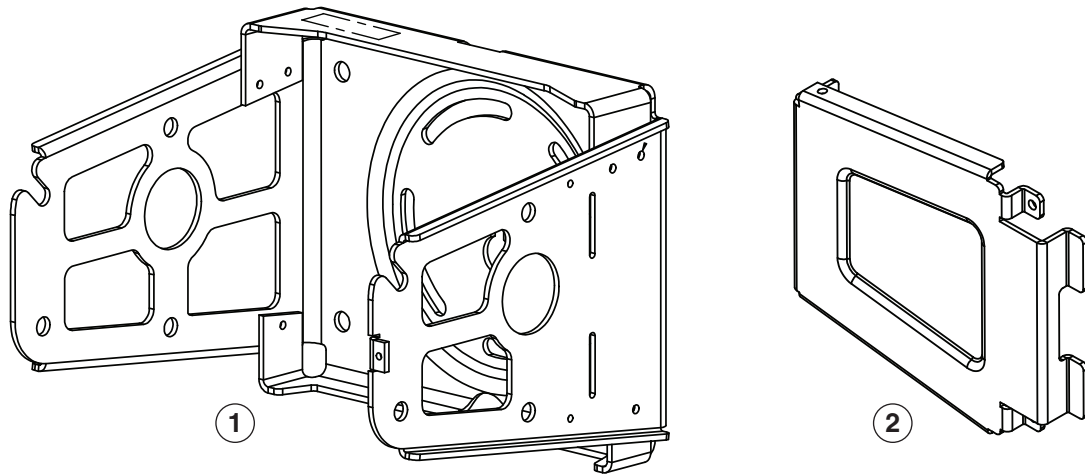

Item	Name	Qty.	Description
1	Mounting bracket	1	Mounts router to mounting plate, which is installed on pole.
2	Mounting bracket security panel (optional)	1	Optional bracket feature, which prevents the unauthorized users from removing the router from the mounting bracket.
Included Hardware			
3	Washer (M8)	12	Use this hardware to attach the mounting bracket to the mounting plate, and the router to the mounting bracket. Assemble the washer, split lock washer, and bolt as described in Assemble Bracket Hardware , page 55.
4	Split lock washer (M8)	12	
5	Bolt (M8 x 1.25)	12	
6	Serrated nut (M8 x 1.25)	1	
7	Security panel screws (8-32)	3	Use these screws to attach the security panel to the mounting bracket.

Band Strap Kit

Use the straps in the Band Strap Kit when you mount the router on a pole larger than 4.5 inches (11.4 cm) in diameter. This installation also requires the pole mount kit and strap tool kit. See [Pole Mount Kit](#), page 46 and [Strap Tool Kit](#), page 49.

Figure 25 Band Strap Kit Contents



Item	Description
1	Steel straps (2)

Strap Tool Kit

Use the tool in the Strap Tool Kit to attach the steel straps included in the band strap kit. Steel straps are required to install the mounting plate on poles larger than 4.5 inches (11.4 cm) in diameter. See [Band Strap Kit, page 48](#).

Note: The tool in the Strap Tool Kit is manufactured and supported by BAND-IT. For more information about the tool, see www.band-it-idex.com.

Figure 26 Strap Tool Kit Contents



Item	Description
1	Strap tool
2	Strap tool documentation (not shown)

Materials and Tools You Supply

You must supply some or all of these items to mount the router on a pole. The items you supply depends on the installation procedure that you use.

Item	Required for These Procedures
13-mm box-end wrench or socket set	Install the Mounting Plate—Poles Up to 4.5 Inches in Diameter, page 51 Install the Mounting Plate—Through-Pole Mounting (Optional), page 54 Attach the Mounting Bracket to the Mounting Plate, page 55
Bolt, standard washer, fender washer, and nut, 5/8 inch (2 sets)—Bolt length depends on the size of the pole used in the installation.	Install the Mounting Plate—Through-Pole Mounting (Optional), page 54
Drill and drill bit	Install the Mounting Plate—Through-Pole Mounting (Optional), page 54
Phillips screwdriver, or other screwdriver for cross-recessed screws	Ground the Router, page 71
Crimping tool or pliers	Ground the Router, page 71

Mounting Instructions

This section includes all the procedures required to mount the router on any supported pole type.

This section covers the following procedures:

- [Router Orientation, page 50](#)
- [Install the Mounting Plate onto a Pole, page 50](#)
- [Attach the Mounting Bracket to the Mounting Plate, page 55](#)
- [Install the Router onto the Mounting Bracket, page 58](#)
- [Mounting the Router onto a Wall, page 67](#)

Router Orientation

When mounting the router on a pole, ensure that:

- The router is oriented with the chassis cabling openings pointing down so the router cables can be correctly connected through the openings and so the router door opens correctly, as shown in [Figure 35 on page 58](#).
- The router is mounted with the hinged access cover facing out.

Install the Mounting Plate onto a Pole

This section describes three different procedures for installing the mounting plate on a pole. Follow the instructions for the pole type used in your installation.

The instructions in these section refer to the mounting plate features shown in [Figure 27 on page 51](#).

- [Install the Mounting Plate—Poles Up to 4.5 Inches in Diameter, page 51](#)
- [Install the Mounting Plate—Poles Larger than 4.5 Inches in Diameter, page 53](#)
- [Install the Mounting Plate—Through-Pole Mounting \(Optional\), page 54](#)

Figure 27 Mounting Plate Details

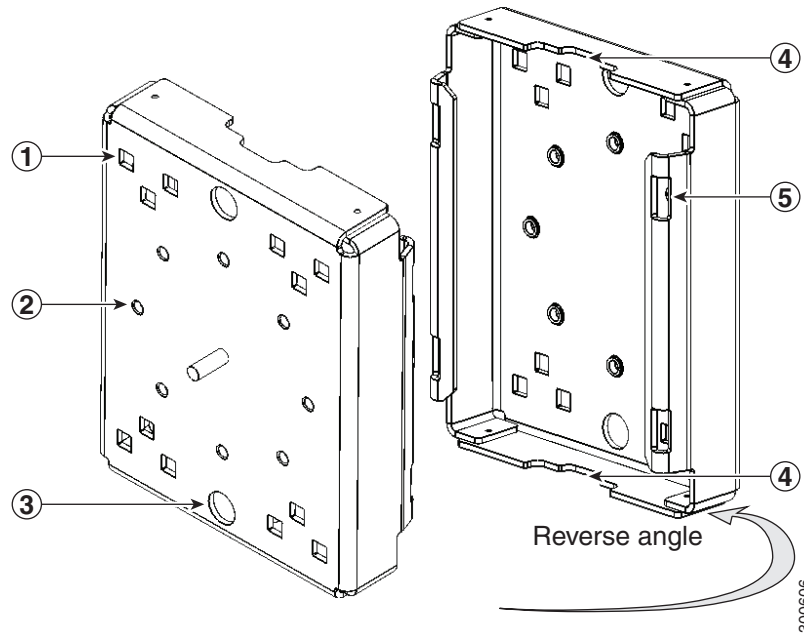

Item	Description	Qty.
1	Carriage bolt holes	4
2	Bracket mount holes	8
3	Clearance holes, 3/4 in.	2
4	Pole clamp notches	2
5	Steel band strap slots	4

Install the Mounting Plate—Poles Up to 4.5 Inches in Diameter

Required Materials

- Mounting plate, carriage bolts, and clamp brackets included in [Pole Mount Kit, page 46](#).
- 13-mm box-end socket wrench

To install the mounting plate on a vertical pole up to 4.5 inches (11.4 cm) in diameter (refer to [Figure 28 on page 52](#) and [Figure 29 on page 53](#)):

1. Select a mounting location on the pole and place the top and bottom pole clamp bracket (1) notches against the pole.
2. Place one of the clamp brackets on the opposite side of the pole, aligning the clamp bracket holes with the top two carriage bolt holes on the mounting plate.

3. Insert a carriage bolt (5) through each of the top two carriage bolt holes on the mounting plate and through the holes in the clamp brackets.
4. Position the each bolt in the clamp so that the bolt is next to the pole, as shown in [Figure 28 on page 52](#).
5. To place the bracket hardware on each carriage bolt (see [Figure 28 on page 52](#)):
 - a. Place the washer (2) and then the split lock washer (3) on the back of each carriage bolt (5).
 - b. Thread the hex nut (4) on each carriage bolt. Place the split-lock washer between the washer and the nut.

Figure 28 Carriage Bolt Hardware Assembly Details

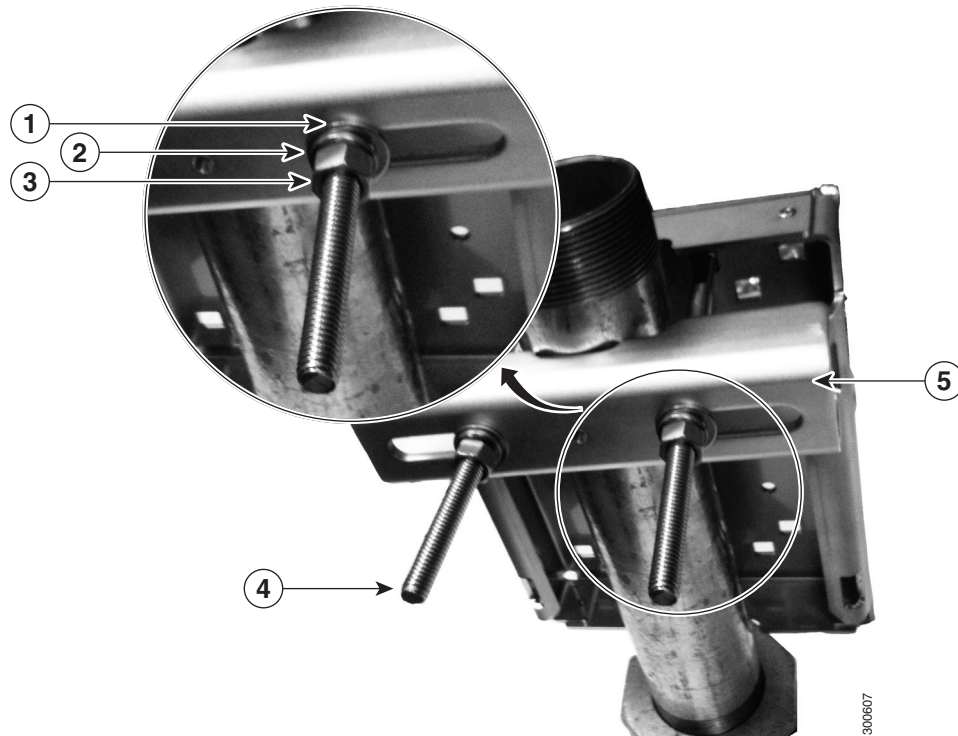

6. Hand tighten the hex nuts (do not overtighten).
7. Repeat Step 3 through Step 6, installing the two bottom carriage bolts and the second clamp bracket at the bottom of the mounting plate.
8. Position the mounting plate and clamp brackets on the pole as needed before further tightening the carriage bolts.
9. Use a socket wrench to evenly tighten all four carriage bolts to finish installing the mounting plate on the pole.

Figure 29 Mounting Plate Installed on Pole with Clamp Brackets

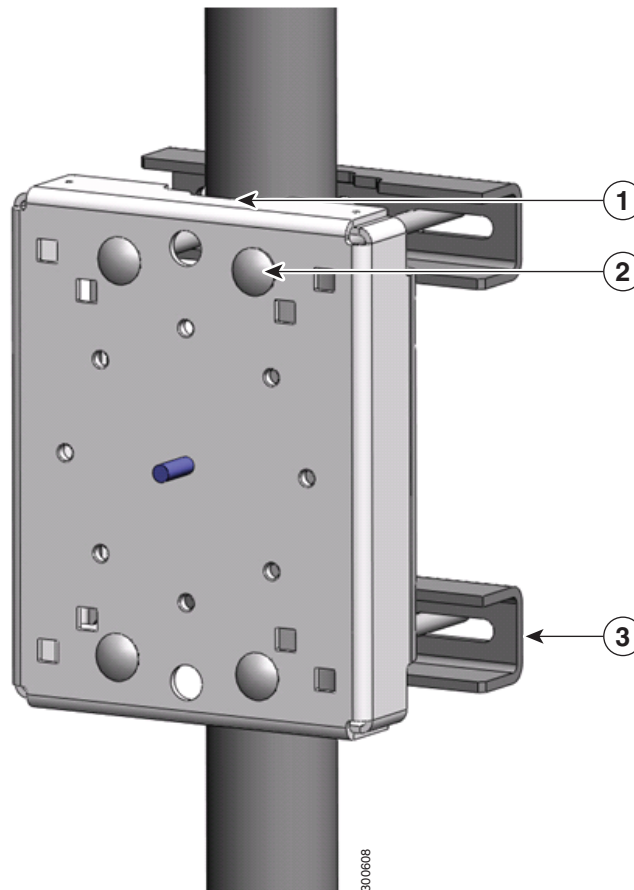

Item	Description
1	Pole clamp notch
2	Carriage bolts (4)
3	Pole clamps (2)

Install the Mounting Plate—Poles Larger than 4.5 Inches in Diameter

Required Materials

- Mounting plate and steel straps included in [Pole Mount Kit, page 46](#).
- BAND-IT tool included in [Strap Tool Kit, page 49](#)
- Torque wrench

To install the mounting plate on a vertical pole that is larger than 4.5 inches (11.4 cm) in diameter (refer to [Figure 30 on page 54](#)):

1. Assemble the straps and the mounting plate by threading the two steel straps through the band strap slots on the mounting plate.
2. Select a mounting location on the pole.

3. Position the mounting plate on the pole as needed and tighten the straps around the pole.
4. Use the BAND-IT strap tool to tighten the metal bands around the pole, following the instructions in the box with the tool. Ensure the metal bands are as tight as possible (approximately 7 ft-lbs).

Note: When the metal bands are tightened to the full tension, the mounting plate cannot be adjusted unless the metal bands are disassembled or cut.

Figure 30 Mounting Plate Installed on Pole with Steel Straps

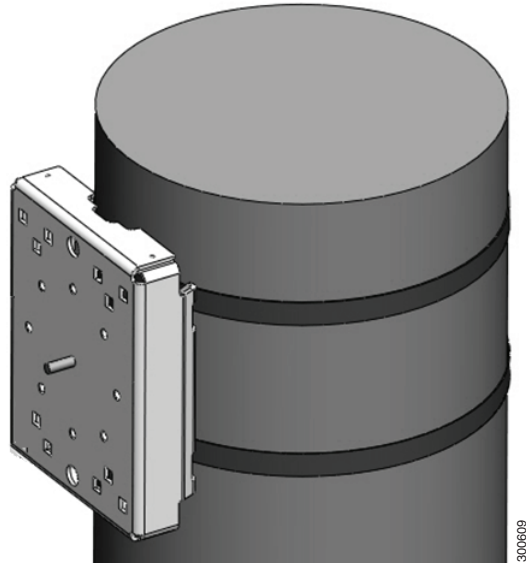

Install the Mounting Plate—Through-Pole Mounting (Optional)

If the pole used in your installation is made of wood, you can optionally install the mounting plate using the procedure described in this section. This is an alternate mounting method to the following two mounting methods, which can also be used when mounting the router on a wood pole:

- [Install the Mounting Plate—Poles Up to 4.5 Inches in Diameter, page 51](#)
- [Install the Mounting Plate—Poles Larger than 4.5 Inches in Diameter, page 53](#)

Required Materials

- Mounting plate included in [Pole Mount Kit, page 46](#).
- Hardware that you supply: 5/8-in. carriage bolt (length depends on the pole size in your installation), standard washer, fender washer, nut (2 sets)
- Tools that you supply: Drill, drill bit (for 5/8-in. through bolts), and 13-mm box-end socket wrench

To mount the router on a wood pole:

1. Place the mounting plate on the selected mounting location on the pole.
2. Mark the drilling locations on the pole through the clearance holes and remove the mounting plate.
3. Drill holes completely through the pole at the points you marked in Step 2.
4. Position the mounting plate over the drilled holes. Align the clearance holes on the mounting plate with the drilled holes.

5. Place a standard washer against one of the clearance holes on the mounting plate, then feed the bolt through the washer, clearance hole, and drilled hole. Push the bolt all the way through the pole. See [Figure 27 on page 51](#).
6. Follow these steps on the opposite side of the pole:
 - a. Place a fender washer on the end of the bolt, and then a nut.
 - b. Hand tighten the nut.
7. Repeat Step 5 and Step 6 for the second bolt.
8. Use a socket wrench to evenly tighten both bolts to finish installing the mounting plate on the wooden pole.

Figure 31 Mounting Plate Installed on Wooden Pole with Through Bolts

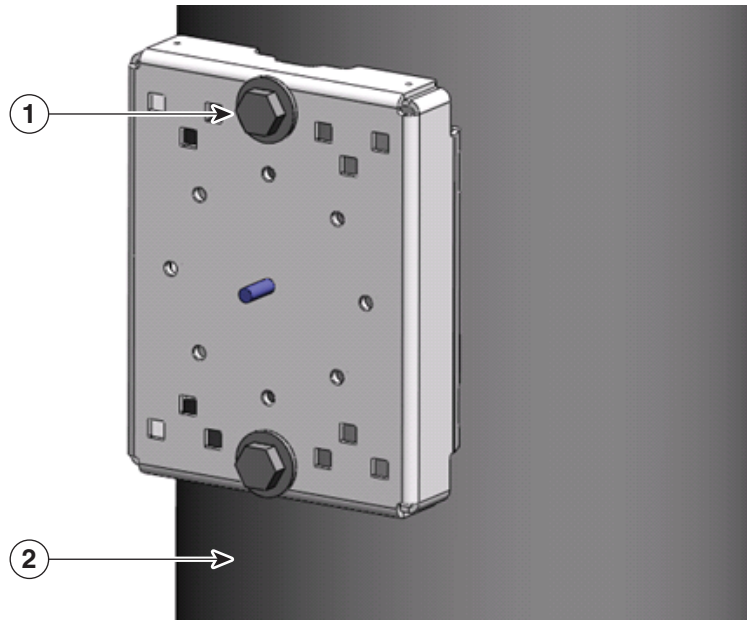

Item	Description
1	Wood pole
2	5/8-in. through bolts (2)

Attach the Mounting Bracket to the Mounting Plate

This section describes how to attach the mounting bracket to the mounting plate.

Assemble Bracket Hardware

Several of the procedures in this section require you to assemble the bracket hardware before installing the bracket. A bracket hardware set consists of one bolt, one washer, one split lock washer, and one nut.

To assemble the bracket hardware:

1. Slide the split lock washer (2) on the bolt (1).
2. Slide the regular washer (3) on the bolt (1).

Place the split-lock washer between the regular washer and the bolt as shown in [Figure 32 on page 56](#).

Figure 32 Assemble Bracket Hardware Sets

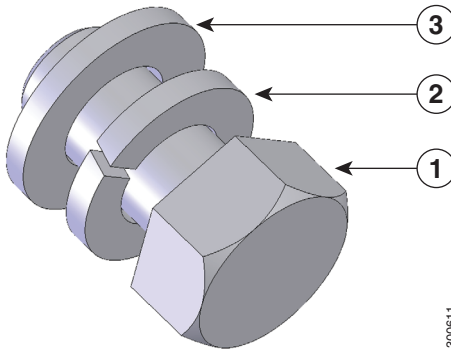

The instructions for the procedures in this section refer to the mounting plate features shown in [Figure 33 on page 56](#).

Figure 33 Mounting Bracket Details

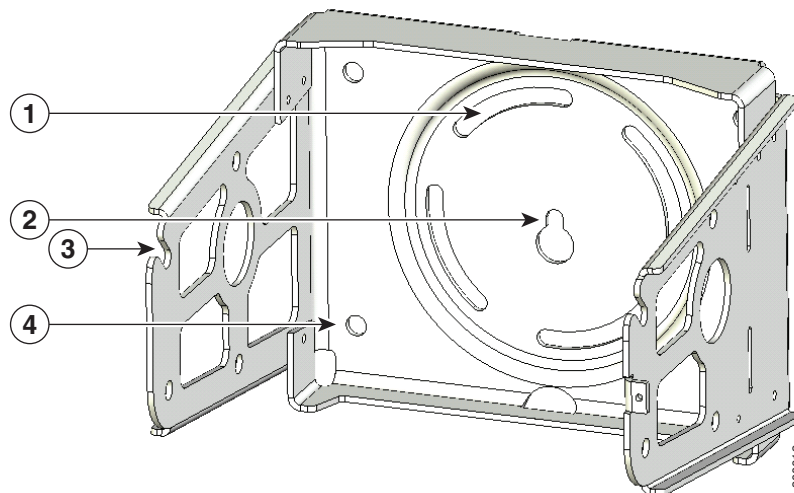

Item	Description
1	Pivot grooves (4)
2	Quick hang notch
3	Quick hang slots (2)
4	Optional wall-mount holes (4)

Note: The mounting plate must be installed as described in [Install the Mounting Plate onto a Pole, page 50](#).

To attach the mounting bracket to the mounting plate (refer to [Figure 34 on page 57](#)):

Required Materials

- Mounting bracket and hardware included in the [Mounting Bracket Kit, page 47](#)
- 13-mm box-end socket wrench

1. Assemble four sets of bracket hardware (washer, split lock washer, and bolt) as shown in [Assemble Bracket Hardware, page 55](#).

2. Place the mounting bracket against the mounting plate by inserting the bracket quick hang notch over the mounting plate quick hang stud (4).
3. Thread the serrated nut onto the quick mount stud (4) and hand tighten (do not overtighten).
4. Align the pivot grooves (2) on the bracket with four of the bracket mount holes (1) on the mounting plate. Follow these guidelines:
 - Each of the four pivot grooves on the bracket must be attached to at least one bracket mount hole on the mounting plate.
 - The final desired orientation of the mounting plate and router determine which bracket mount holes are used.
 - Mount the router as described in [Router Orientation, page 50](#).
5. Insert one bolt assembly (3) through one of the pivot grooves (2) on the bracket and then through the corresponding bracket mount hole on the mounting plate.
6. Repeat Step 5 for the remaining bolt assemblies.
7. Position the mounting bracket onto the mounting plate as needed before further tightening the bolts.
8. Use a socket wrench to evenly tighten all four bolts and the serrated nut to finish installing the bracket on the plate. Use a torque of 6-7 foot-pounds when tightening the bolts and nut.

Figure 34 Mounting Bracket Attached to Mounting Plate

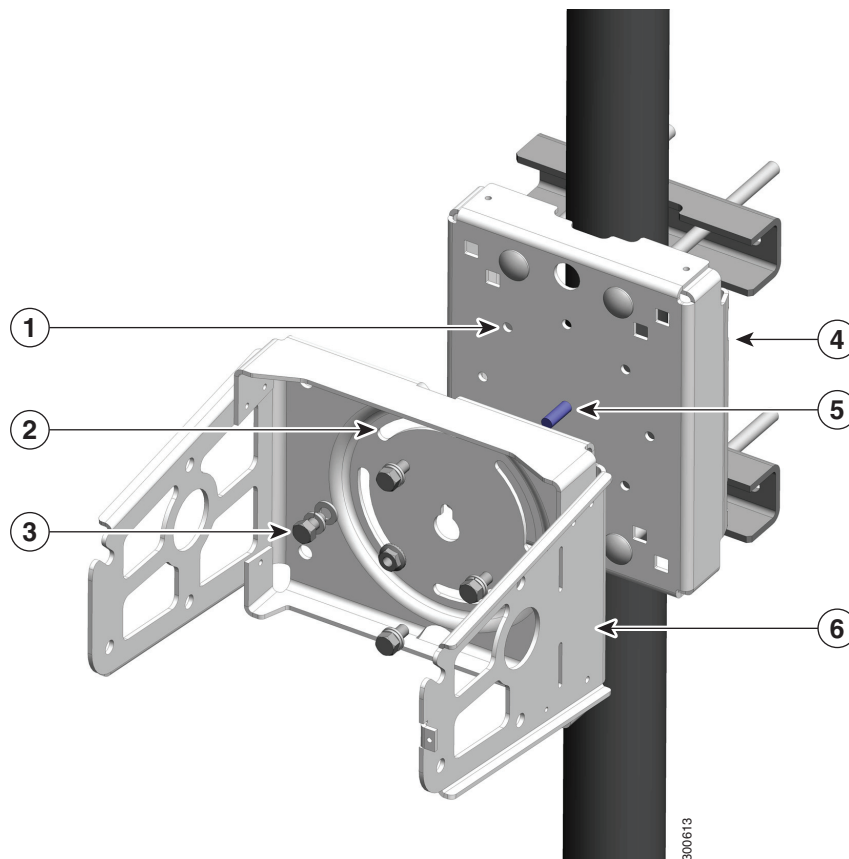

Install the Router onto the Mounting Bracket

This section describes how to attach the router to the mounting bracket. The mounting bracket is installed on the mounting plate (included in the Cisco pole mount kit), which is installed on a supported pole type. See [Pole Mount Kit, page 46](#).

The instructions for the procedures in this section refer to the mounting bracket kit contents shown in [Figure 24 on page 48](#) and the bracket features described in [Figure 33 on page 56](#).

Note: Refer to [Install the Optional Security Panel, page 64](#) for how to install the optional security panel on the bracket.

Figure 35 Router Installed in Mounting Bracket

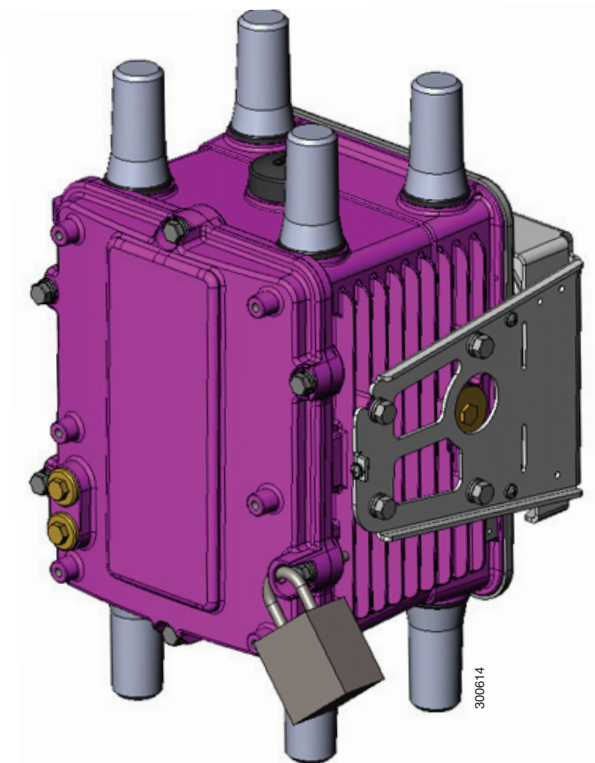

Required Materials

- Mounting bracket and hardware included in [Mounting Bracket Kit, page 47](#).
- Socket wrench that you supply.

To mount the router on the bracket (refer to [Figure 36 on page 59](#) and [Figure 37 on page 59](#)):

1. Assemble eight sets of bracket hardware (washer, split lock washer, and bolt) as shown in [Assemble Bracket Hardware, page 55](#).
2. Attach one set of hinge bolt hardware to the mounting bracket connector shown in [Figure 37 on page 59](#) (1).

Do not tighten the hardware until Step 6. There must be enough space between the washer and the router to slide the router onto the bracket.

3. Repeat Step 2 on the other side of the router.
4. Slide the router onto the bracket by inserting the hinge bolts you attached in Step 2 into the bracket quick hang slots (2).

Figure 36 Attach One Hinge Bolt to Each Side of the Router

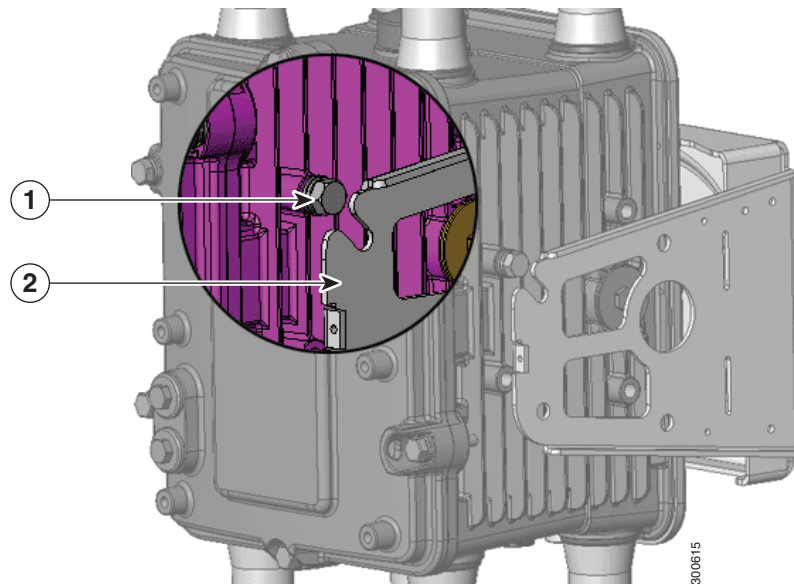

5. Attach the six remaining sets of hardware to each side of the bracket and router (3 sets on each side), as shown in [Figure 37 on page 59](#).
6. Use a socket wrench to evenly tighten all four bolts, using 6-7 foot-pounds of torque.

Figure 37 Attach Remaining Bolts to Bracket and Router

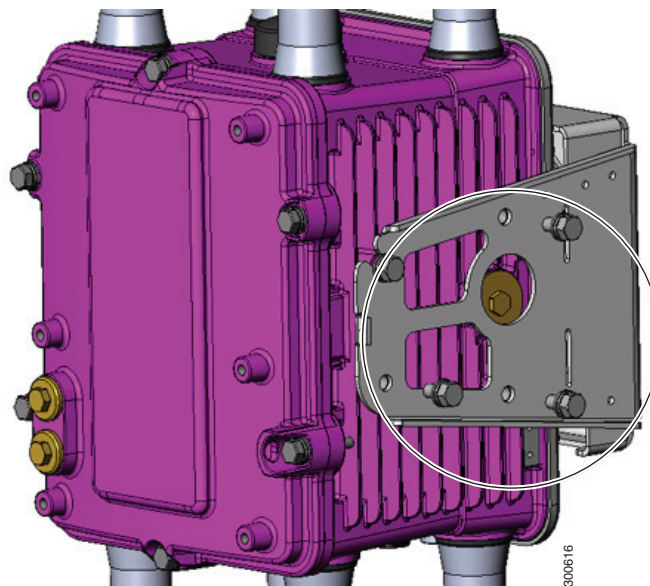

Simple Mounting Bracket for Pole Mounting of CGR1240

Required Materials

- Simple Mounting Bracket and hardware that is included in the kit (see [Figure 38](#)) which includes:

-
- (2) Adapters
 - (1) Bracket
 - (8) 1/4" Bolt

1. Attach the two (2) adapters to the bracket using 1/4 inch bolts as shown in [Figure 38 Constructing the Mounting Bracket \(CISCO-CGR-PM-BRKT\)](#), page 61. Be sure to attach the adapters to the brackets as illustrated.

Figure 38 Constructing the Mounting Bracket (CISCO-CGR-PM-BRKT)

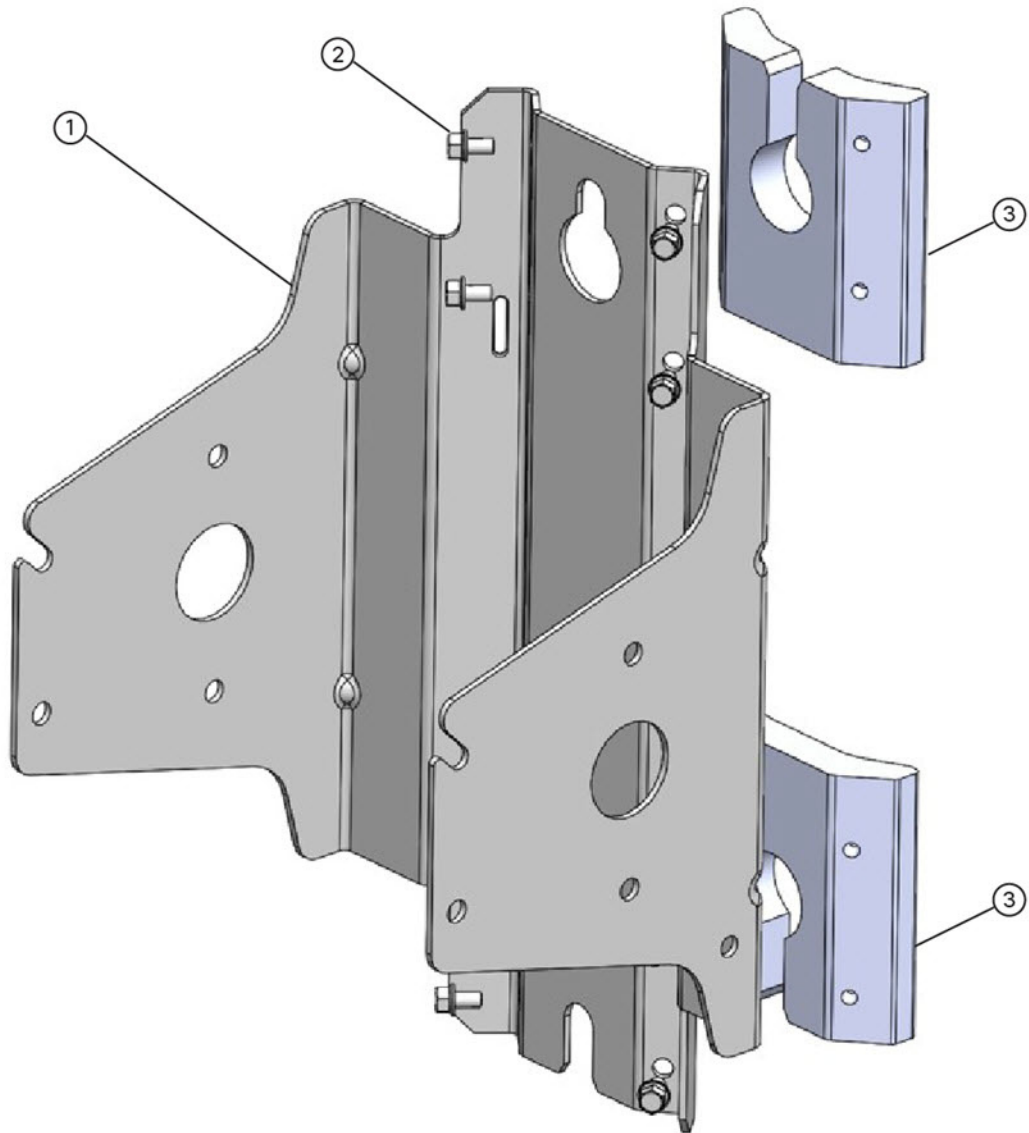

Item Number	Description
1	Mounting Bracket (CISCO-CGR-PM-BRKT)
2	1 1/4" Bolt (quantity of 8)
3	Adapter (quantity) of two

2. Attach the Mounting Bracket to a pole (wooden or metal) by following the pole-specific instructions below:

- To attach the bracket to a Wooden Pole, you will need to attach the bracket using two (2) 5/8 inch bolts specified for wooden poles. In addition, you can also use Band-it strips on the wooden poles, if desired.

-
- To attach the bracket to a Metal Pole, use Band-it Straps as shown in [Figure 39 Attach the CGR1240 Custom, Simple Mounting Bracket to Wooden or Metal Pole](#), page 63.

Figure 39 Attach the CGR1240 Custom, Simple Mounting Bracket to Wooden or Metal Pole

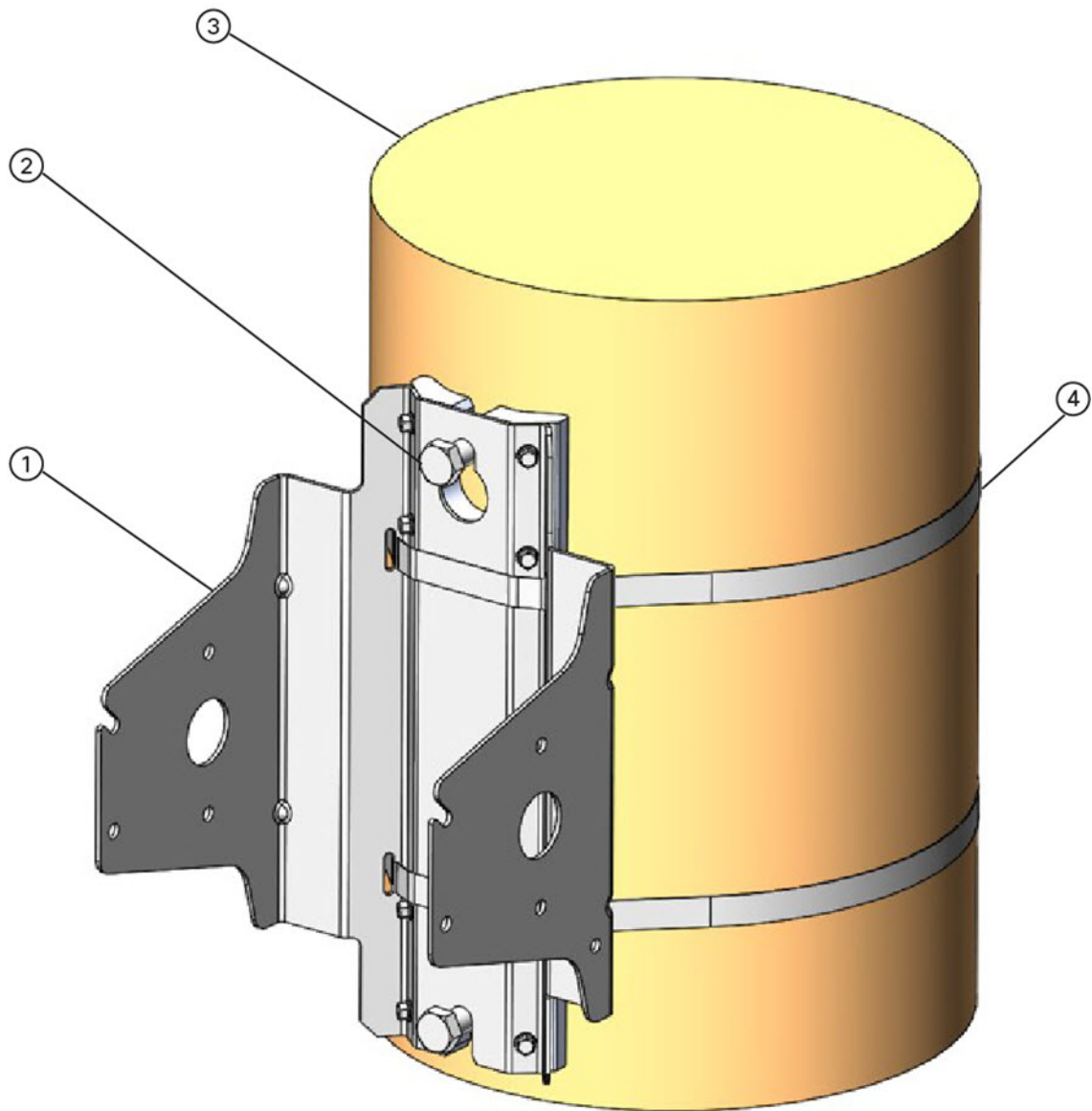

Item Number	Description
1	Bracket Assembly
2	5/8" Bolts for wooden poles (Quantity of 2)
3	Pole (metal or wooden)
4	Band-it straps for metal or wooden pole

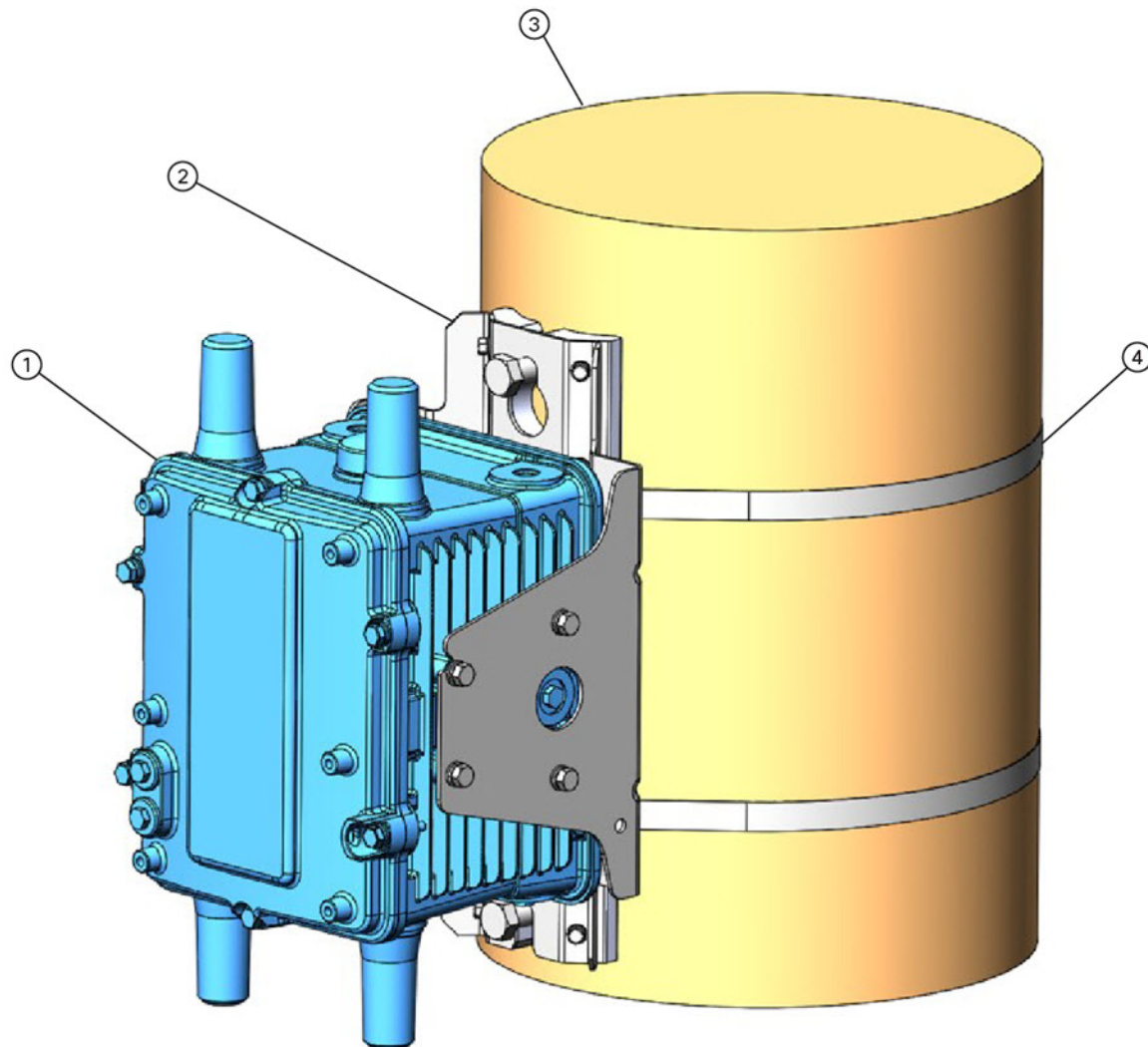

Item Number	Description
1	CGR 1240
2	Bracket Assembly with 5/8" Bolts for wooden poles (Quantity of 2 Bolts)
3	Pole (metal or wooden)
4	Band-it straps for metal or wooden pole

Install the Optional Security Panel

The Cisco includes an optional security panel. See [Mounting Bracket Kit, page 47](#). The security panel prevents unauthorized users from removing the router from the mounting bracket, and also prevents unauthorized access to the SD Card Slot (see [SD Card Slot Access for Bracket-Mounted Routers, page 69](#)).

Required Materials

- Security panel and the hardware (three 8-32 PNH screws) included in the mounting bracket kit.
- Phillips screwdriver

Figure 40 Security Panel Details

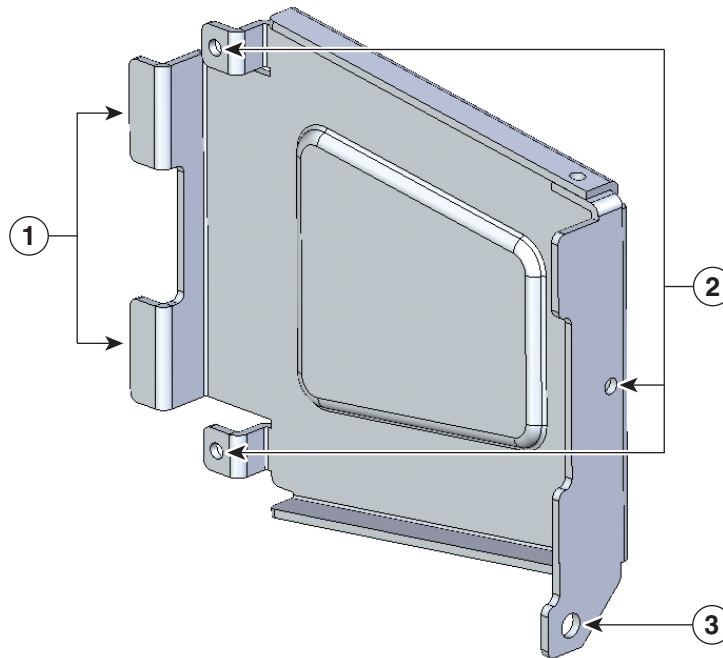

Item	Description
------	-------------

- | | |
|---|---|
| 1 | Insert the security panel tabs into the corresponding notches on the mounting bracket. |
| 2 | Secure the security panel to the bracket at these locations, using the screws included in the Mounting Bracket Kit, page 47 . |
| 3 | Insert the captive screw located in the router door lock block through this hole when closing the router door. |

To install and secure the security panel to the bracket and router:

1. Loosen the captive bolt that is located inside router door lock post. For lock post location, see [Figure 59 on page 82](#).
2. Install the security panel on the bracket by inserting the security panel tabs into the corresponding slots on the bracket as shown in [Figure 41 on page 66](#).

Note: For clarity, the router is not shown here. During this procedure, the router is mounted in the bracket.

Figure 41 Assemble Bracket and Security Panel

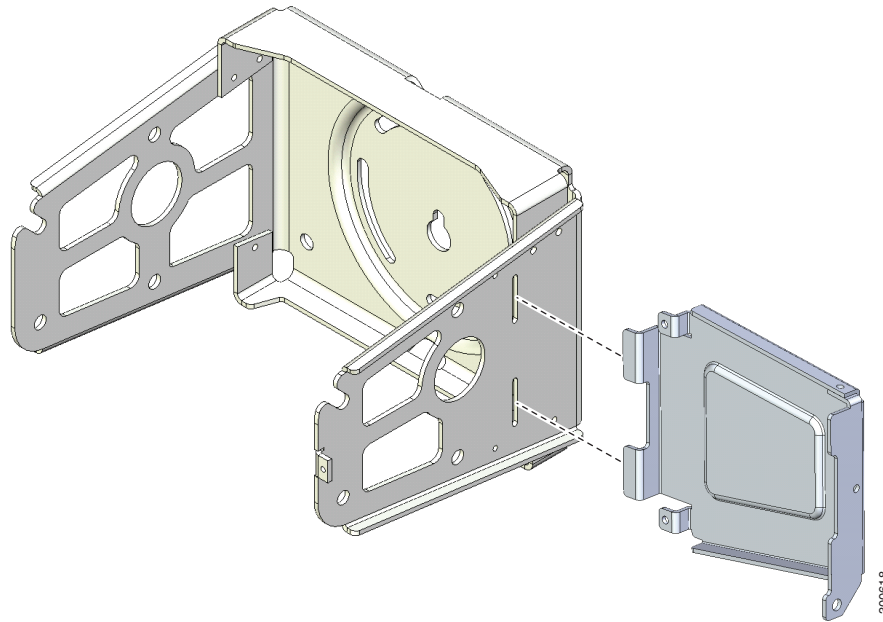

3. Swing the panel shut over the bracket, aligning the three screw holes on the panel with the corresponding holes on the bracket.
4. Insert the three security panel screws (included in the mounting bracket kit) and tighten using the Phillips screw driver (see [Figure 42 on page 66](#)).

The router door captive bolt inside the door lock post is aligned over the bracket hole as shown in [Figure 43 on page 67](#).

Note: For clarity, the router is not shown here. During this procedure, the router is mounted in the bracket.

Figure 42 Security Panel Attached to Bracket with Included Screws

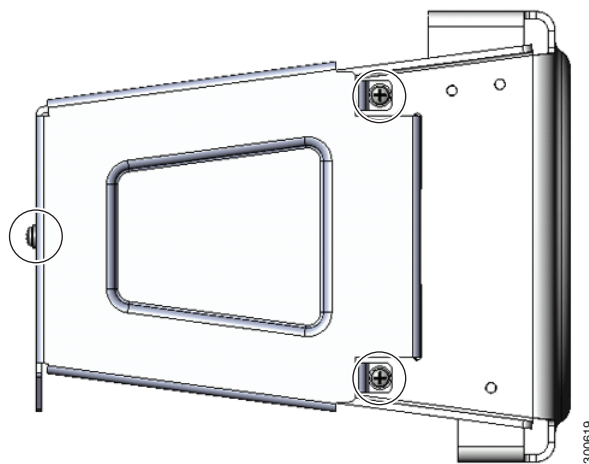

5. Tighten the captive bolt (using 6-7 ft-lbs of torque) located inside the router door lock post (**2** in [Figure 43 on page 67](#)), ensuring the bolt extends into the security bracket (**3** in [Figure 43 on page 67](#)).

Figure 43 Router Door Closed with Security Panel Installed

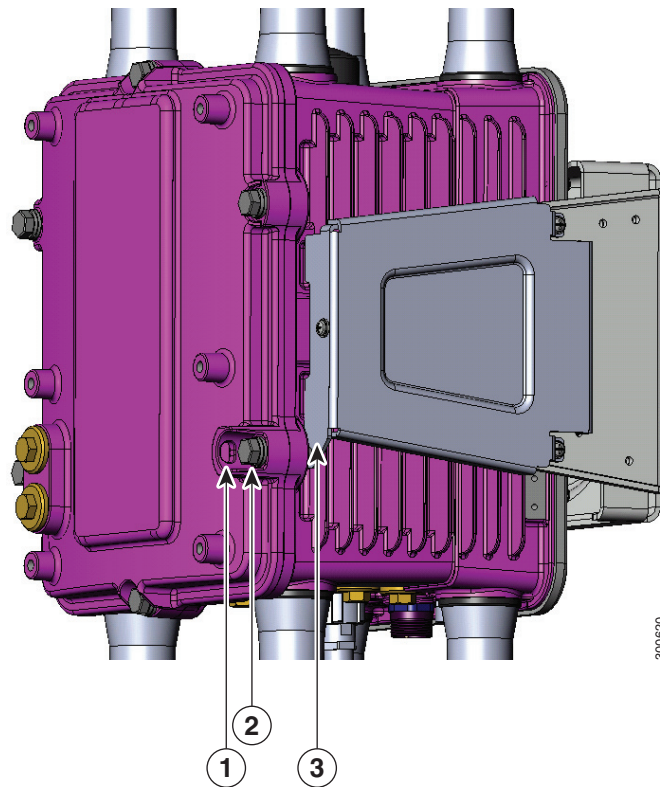

6. Insert a lock that you provide through the router door lock post (Item 1 in [Figure 43 on page 67](#)).

The SD card can be accessed only by users who have access to the router door lock. The router can be removed from the mounting bracket only by users who have access to the router door lock.

Mounting the Router onto a Wall

The mounting bracket has wall-mount holes that you can use to mount the router directly onto a wall.

To mount the router on a wall, you must provide the hardware and anchors that can be used with the wall material in the installation environment.

Caution: The wall material and hardware that you use to mount the router must be able to support the weight of the router with two modules installed: **approximately 23.0 pounds (10.4 Kg)**. The bolts must support a minimum of 150 in-lbs of pull out moment (FoS not included).

Router Orientation When Mounting

When mounting the router onto a wall, ensure that the router is oriented with the chassis cabling openings pointing downward so the router cable hangs down.

Caution: Never mount the router with the bottom (facing up) or to the side.

Wall-Mount Location

Identify an area on a wall that meets the safety, space, and environmental requirements described in [Site Requirements, page 5](#).

Wall-Mount Height

Mount the router at a height where you can view the top of the module-side panel, and at which the cables can be managed without adding stress to the router ports.

Wall-Mount Hardware Distance

Mount any reinforcement hardware that you provide to the wall the correct distance apart so that when the bolts are installed through the mounting bracket wall mount holes (Item 1, [Figure 44 on page 68](#)), they align with the holes in the wall.

Figure 44 Distance for Wall-Mounting Hardware

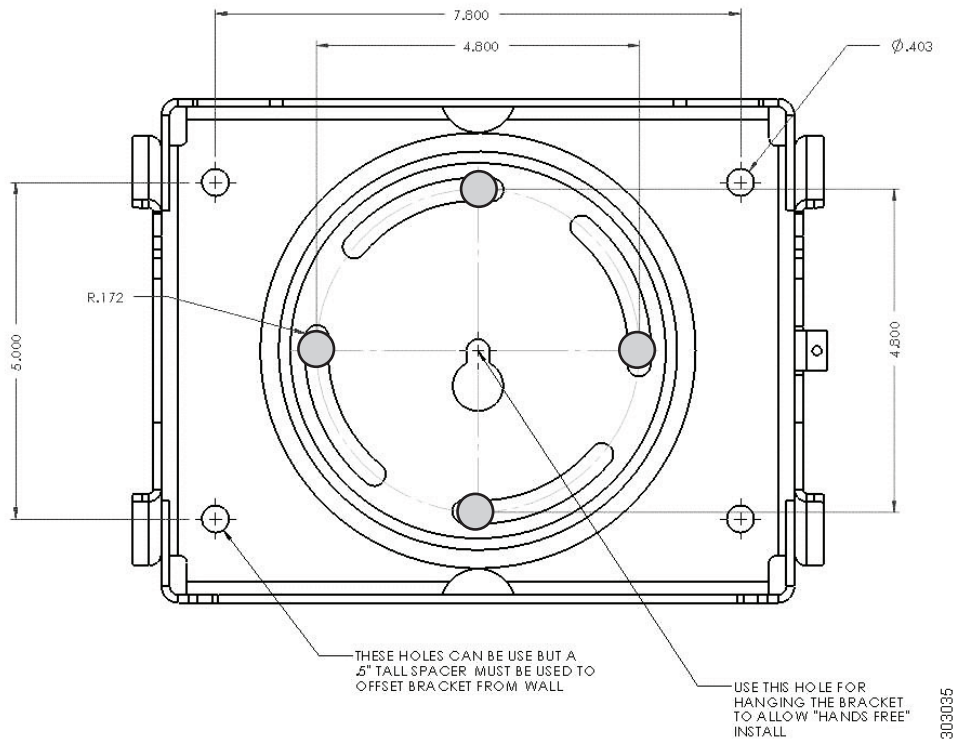

Required Materials

- Mounting bracket. For bracket dimensions, see [Figure 44 on page 68](#) and [Figure 45 on page 69](#).
 - Socket wrench that you supply
 - 5/16th-in. or M8 bolts or equivalent (5) (customer supplied)
 - Bolt reinforcement hardware (for example, wall shoe anchor bolts) (5) (customer supplied)
1. Place the mounting bracket onto the location on the wall. Mark the locations of the four mounting holes and the one center hole.
 2. **(If Required)** Install the bolt reinforcement hardware onto the wall at the five hole locations.
 3. Install the bolt into the center hole location. Do not fully thread in; leave bolt extended about 1/4".
 4. Align the center hole of the mounting bracket over the previously installed bolt so that the bracket rests on the bolt.

Figure 45 Securing the Wall-mount Bracket to the Wall

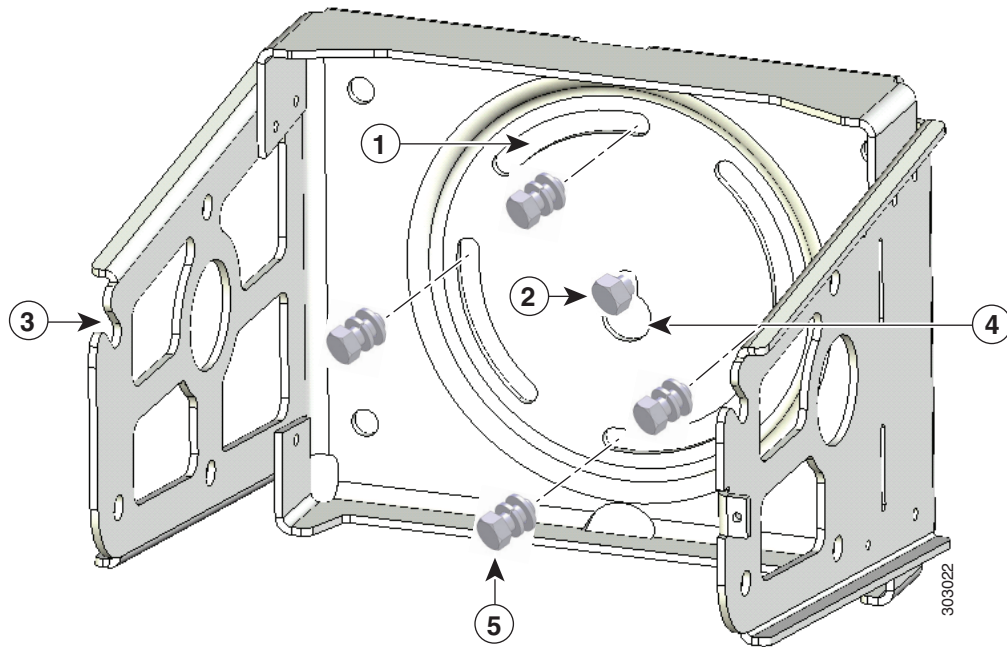

Item	Description
1	Bracket: bolt holes (4)
2	Customer-supplied hardware: 5/16th-in. or M8 bolts or equivalent (1)
3	Mounting bracket (1)
4	Center mounting hole (1)
5	Customer-supplied hardware: 5/16th-in. or M8 bolts or equivalent (4) (same as #2 above)

5. Install the four mounting bolts through the bracket and into the wall.

Secure properly by hand-tightening in a star pattern order, beginning with the first bolt, tighten using the wrench. Torque based on hardware and wall material. Torque center bolt last.

6. Install the router onto the mounting bracket. See [Install the Router onto the Mounting Bracket, page 58](#).
7. Install the optional security panel.

SD Card Slot Access for Bracket-Mounted Routers

When the Cisco mounting bracket is attached the router according to the instructions in this section, the bracket blocks access to the SD card port slot the router exterior.

Note: You must open or remove the mounting bracket security panel to see or access the SD card port.

To access the SD card slot (1) without removing the router from the bracket or any mounting installation that uses the bracket (refer to [Figure 46 on page 70](#)):

1. On one side of the router, remove the three bolts shown in [Figure 37 on page 59](#).
2. Loosen but do not remove the fourth bolt that is inserted in the quick hang slot.

3. Repeat Step 1 through Step 2 on the other side of the router.
4. Tilt the bracket on the quick mount slot, as shown in [Figure 46 on page 70](#).

Caution: When you finish using the SD card slot, reinstall and tighten all eight bolts with 6-7 foot-pounds of torque. The router must be securely attached to the mounting bracket with four bolts on each side.

Figure 46 Tilt Mounting Bracket for SD Card Slot Access

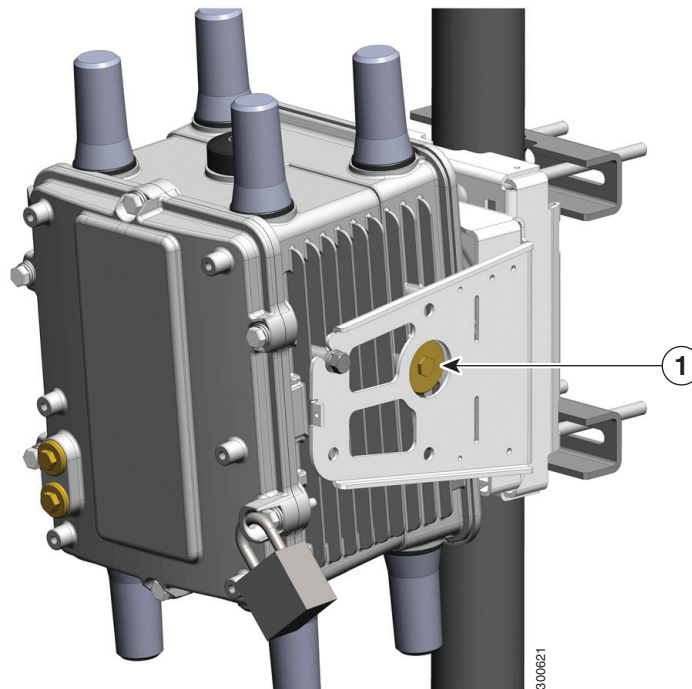

Grounding Instructions

In all installations, after the router is mounted, you must properly ground the unit according to the instructions in this section before connecting network and power cables as described in the [Installing the Router, page 85](#).

Warning: This equipment must be externally grounded using a customer-supplied ground wire before power is applied. Contact the appropriate electrical inspection authority or an electrician if you are uncertain that suitable grounding is available. Statement 366

Warning: Installation of the equipment must comply with local and national electrical codes. Statement 1074

Grounding Hardware

The router is shipped with a grounding kit, shown in [Figure 47 on page 71](#).

Figure 47 Router Grounding Kit Contents



Item	Description	Qty.
1	Grounding lug	1
2	Screws	2

Materials You Supply

You must provide the tools listed in [Materials and Tools You Supply, page 50](#).

Ground the Router

Note: You can perform these steps when the mounting bracket security panel is installed.

To ground the router:

1. Use the appropriate crimping tool or pliers to crimp the 6-gauge ground wire (included in the grounding kit) to the grounding lug.
2. Connect the grounding lug to the router chassis ground connection point shown in [Figure 48 on page 72](#) using the supplied grounding screws.

Note: Tighten the grounding screws to 20-24 in-lbs of torque. Do not overtighten!

3. If necessary, strip the other end of the ground wire and connect it to a reliable earth ground, such as a grounding rod or an appropriate grounding point on a pole that is grounded.

Figure 48 Grounding Lug Connectors (Chassis Ground Connection Point)

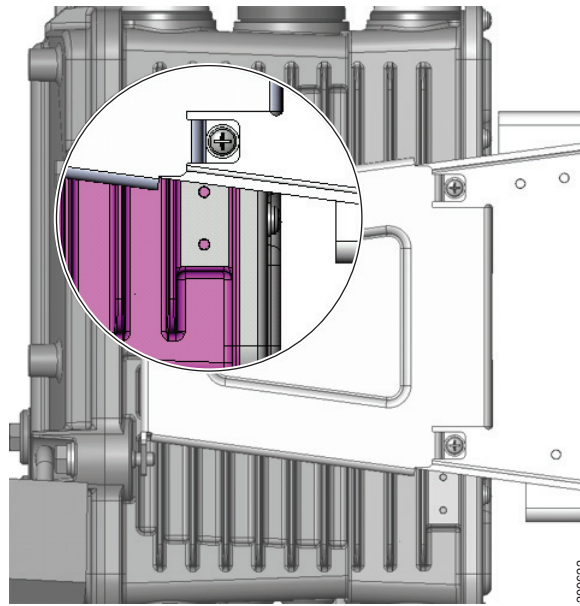

Bracket Dimensions

This section contains specifications for the Cisco mounting brackets used with the router, and includes:

- Mounting Bracket Dimensions, [Figure 49 on page 73](#)
- Mounting Bracket Security Panel Dimensions, [Figure 50 on page 73](#)
- Pole Plate Dimensions, [Figure 51 on page 74](#)
- Pole Mount Plate Clamp Dimensions, [Figure 52 on page 74](#)

Figure 49 Mounting Bracket Dimensions

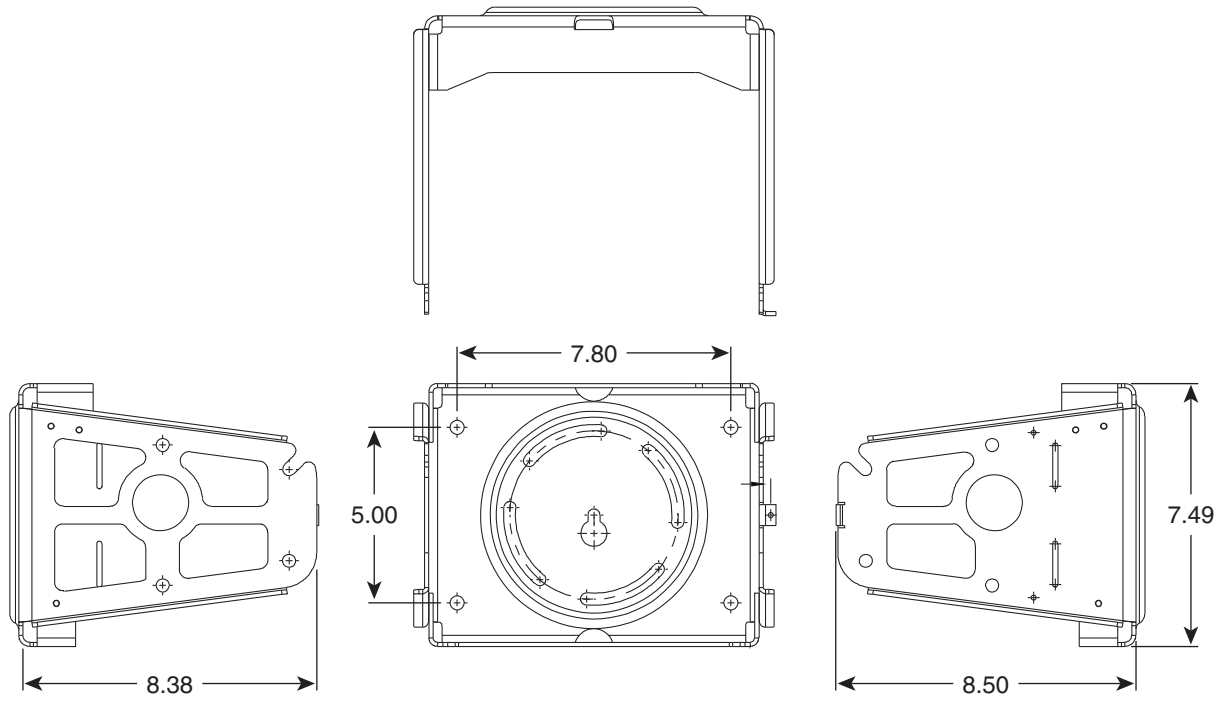

300624

Figure 50 Mounting Bracket Security Panel Dimensions

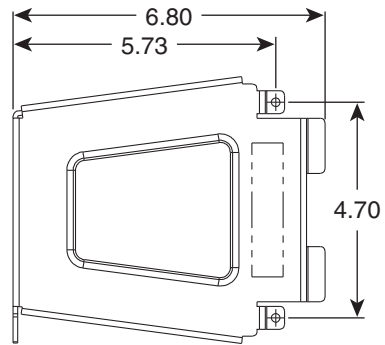

300625

Figure 51 Pole Mount Plate Dimensions

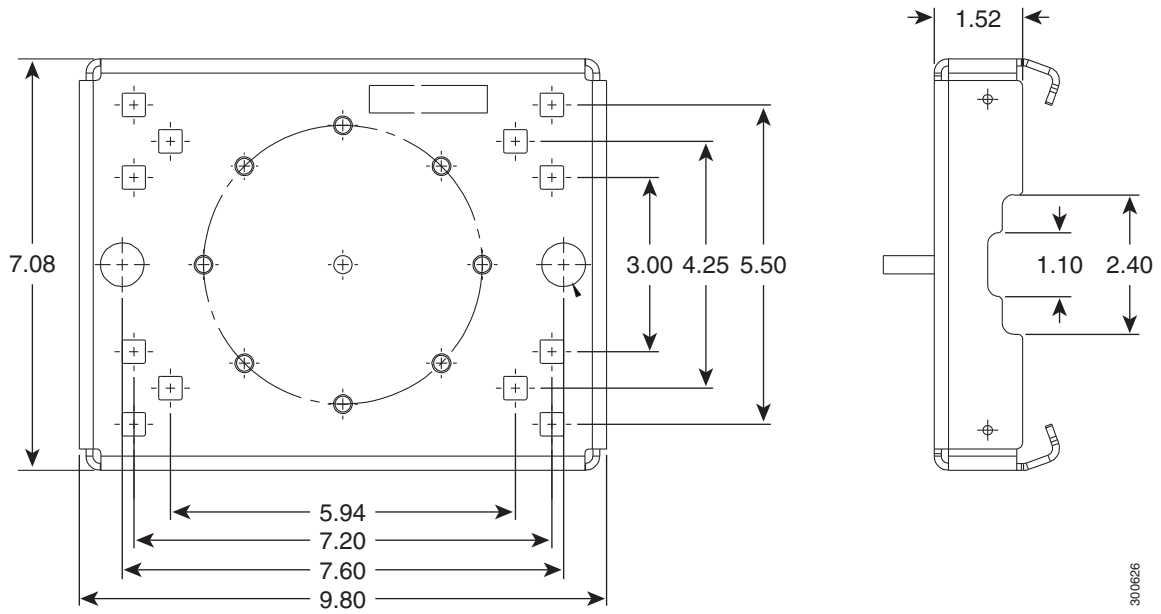
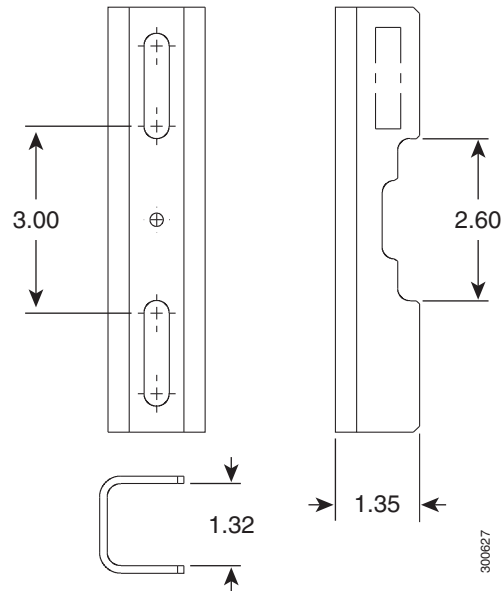

Figure 52 Pole Mount Plate Clamp Dimensions





Opening and Closing the Router Chassis

This section describes how to open the Cisco 1240 Connected Grid Router (CGR 1240 or router) door so that you can access the interior of the chassis.

These topics are discussed:

- [Opening the Router Door, page 75](#)
- [Door Features, page 80](#)

Opening the Router Door

To access the router interior, you must open the router front door. Many of the router hardware installation tasks require you to open the router door and access the router interior. These tasks include:

- Installing Cisco Connected Grid modules
- Installing some module antenna models
- Connecting and cabling the router ports
- Installing battery backup units
- Installing a non-Cisco module on the router
- Using the power and reset buttons
- Viewing the LEDs on the router interior

Preparing to Open the Door

The router door can be opened while the router is powered on and connected to the network. Take any safety precautions described in [Safety Information, page 75](#).

Tools You Supply

You must provide a 1/2-inch (13-mm) socket wrench to open and close the router chassis door.

Safety Information

Read the safety warnings in [Installation Safety and Site Preparation, page 3](#).

Captive Bolts

The router door features six captive, M8 bolts, shown in [Figure 53 on page 76](#).

Figure 53 Router Door, Showing Captive Bolts

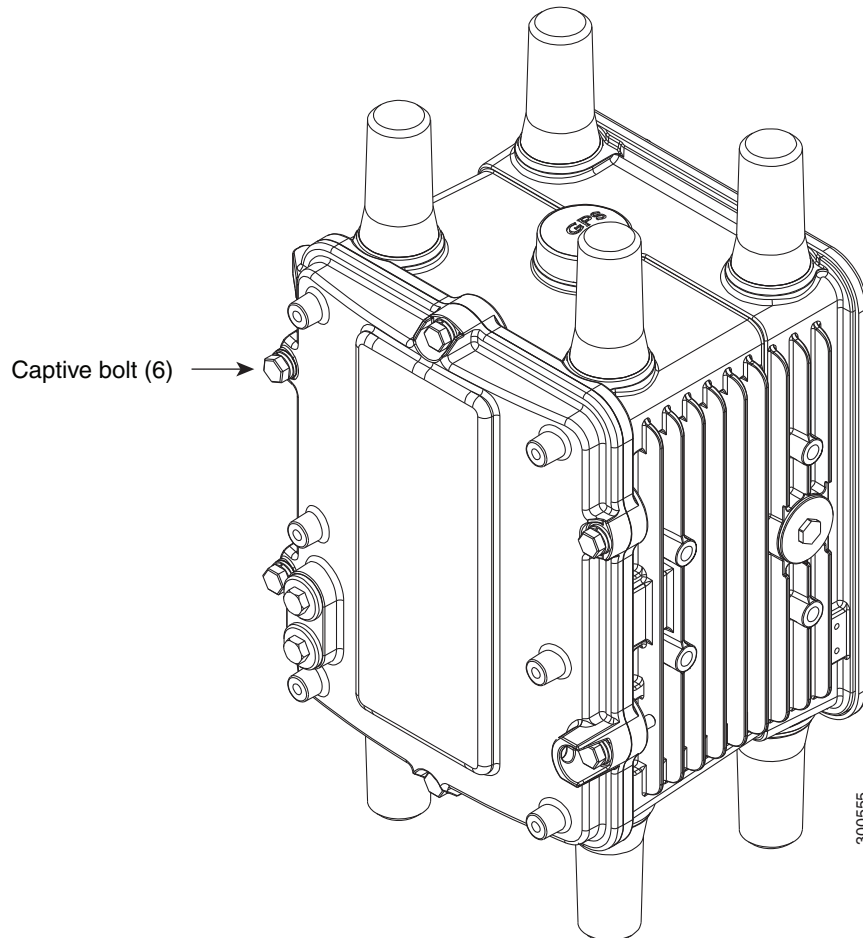

Order of Loosening and Tightening Door Bolts

Cisco recommends that you loosen and tighten the door bolts in the order shown in the following sections.

The chassis door features an environmental seal that protects the chassis against environmental elements when the door is closed. This seal creates pressure, which can cause the door to open suddenly when the last bolt is loosened.

- When opening the door, alternate loosening bolts on each side of the chassis, in the order shown in [Figure 54 on page 77](#), to evenly release the door pressure.
- When closing the door, do not tighten the bolts on the hinge-side of the door first. Tightening the bolts on the hinge-side first can place too much pressure on the door hinges. Tighten the bolts in the order shown in [Figure 55 on page 78](#).

Figure 54 Recommended Order of Loosening Bolts

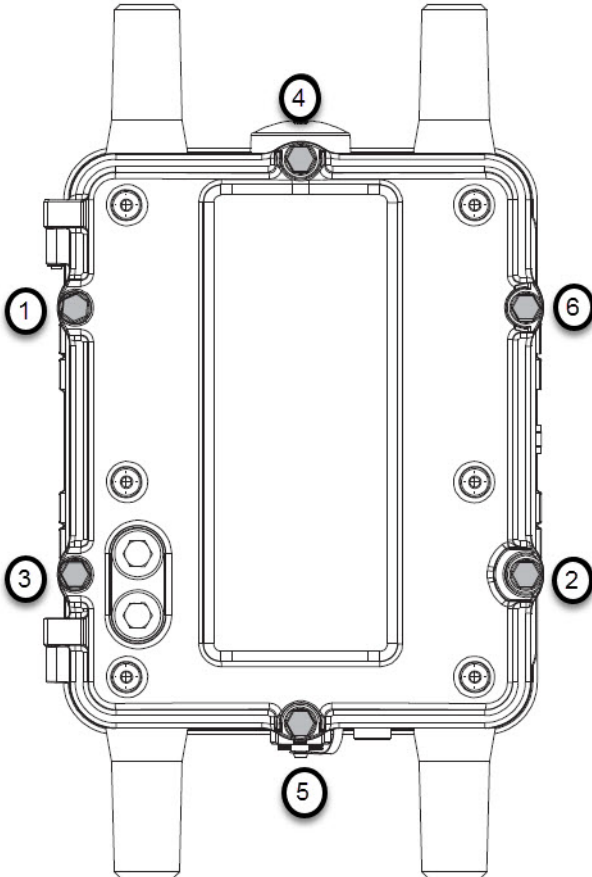
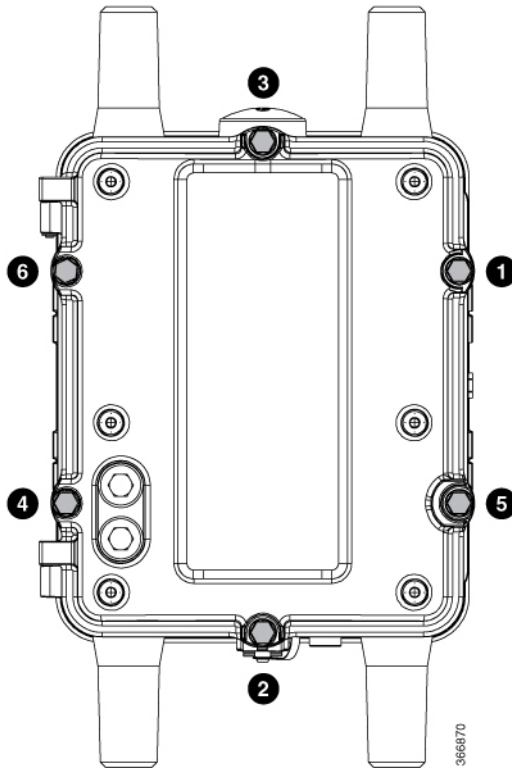

Figure 55 Recommended Order of Tightening Bolts



Opening the Door

1. To open the door, use the socket wrench to loosen all six captive bolts in the order shown in [Figure 54 on page 77](#).

Note: The bolts should not be removed from the door, simply loosened until they wiggle. [Figure 56 on page 79](#) is a detailed view of a captive bolt.

2. After all six bolts are loose, swing the door open on the left-side hinges, as shown in [Figure 57 on page 80](#).

Caution: The door gasket creates a seal when the door is closed, so the door might open suddenly when the last bolt is loosened.

Closing the Door

1. Verify that the door seal is clean and that all cables are tucked back into the chassis.
2. To close the door, use the socket wrench to evenly tighten to 3-4 ft-lbs all six bolts in the order shown in [Figure 55 on page 78](#).
3. Evenly tighten the bolts again, in the order shown in [Figure 55 on page 78](#), this time using 6-7 ft-lbs of torque.
4. Replace any locking mechanism, such as a padlock, on the door lock post.

Figure 56 Captive Bolt Detail

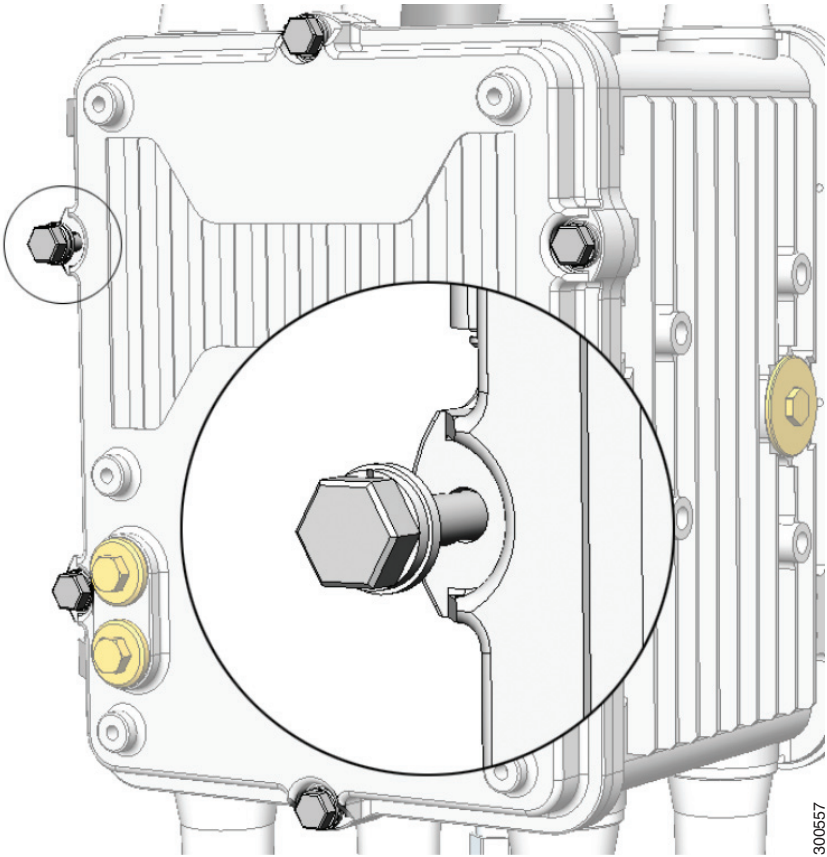
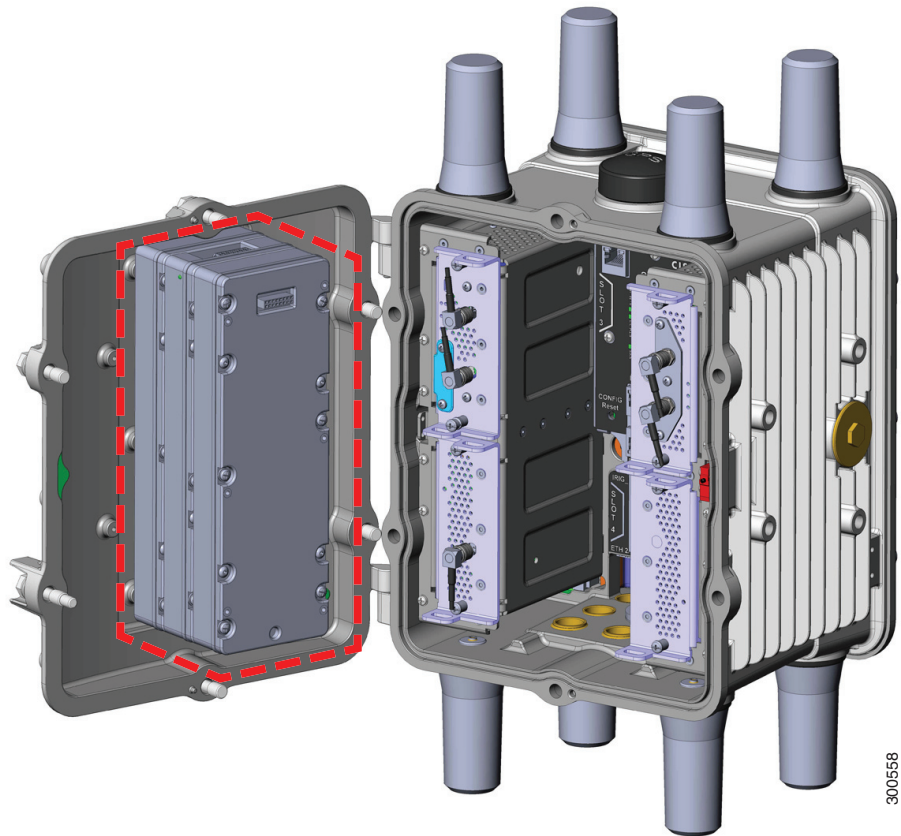

Figure 57 Router Door Open



Door Features

This section describes these door features:

- [Door Sensor, page 80](#)
- [Support for Exterior Door Lock, page 81](#)

Door Sensor

The chassis hardware features a pressure-sensitive alarm switch, shown in [Figure 58 on page 81](#), which detects when the router door opens or closes and alerts the operator to a potential security breach.

When the switch detects that the door has been opened or closed, it sends an event message to the router. The event message is stored in the router log file.

These are examples of the door state event messages:

```
Sep 24 08:04 Router %$ VDC-1 %$ %FCPLMGR-2-FCPLMGR_DOOR_ALARM: door/lid has been closed
Sep 24 08:04 Router %$ VDC-1 %$ %FCPLMGR-2-FCPLMGR_DOOR_ALARM: door/lid has been open
```

Figure 58 Door Open Detection Switch Detail

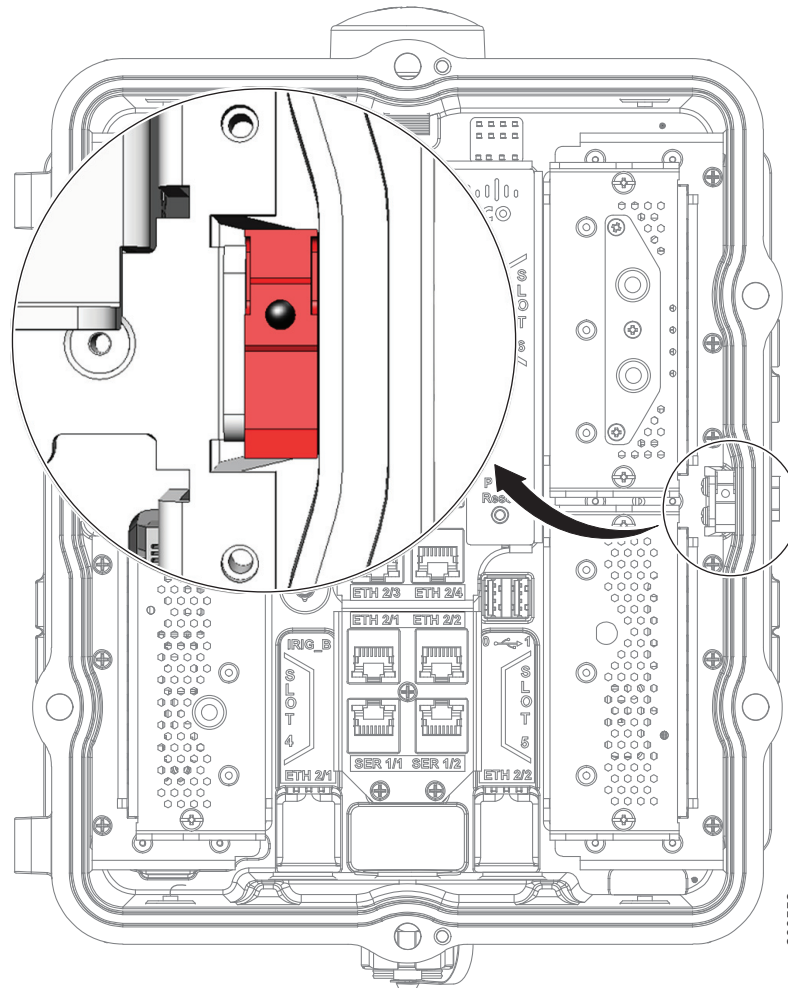

Support for Exterior Door Lock

The router door has a single lock post, shown in [Figure 59 on page 82](#), which supports an external lock to prevent unauthorized access to the router interior:

- You must provide the lock
- The lock post supports a lock with a shank diameter of up to 5/16 inches (such as Master Lock part number 176).

[Figure 60 on page 83](#) shows an external lock applied to the lock post on the router door.

Figure 59 Door Lock Post Detail

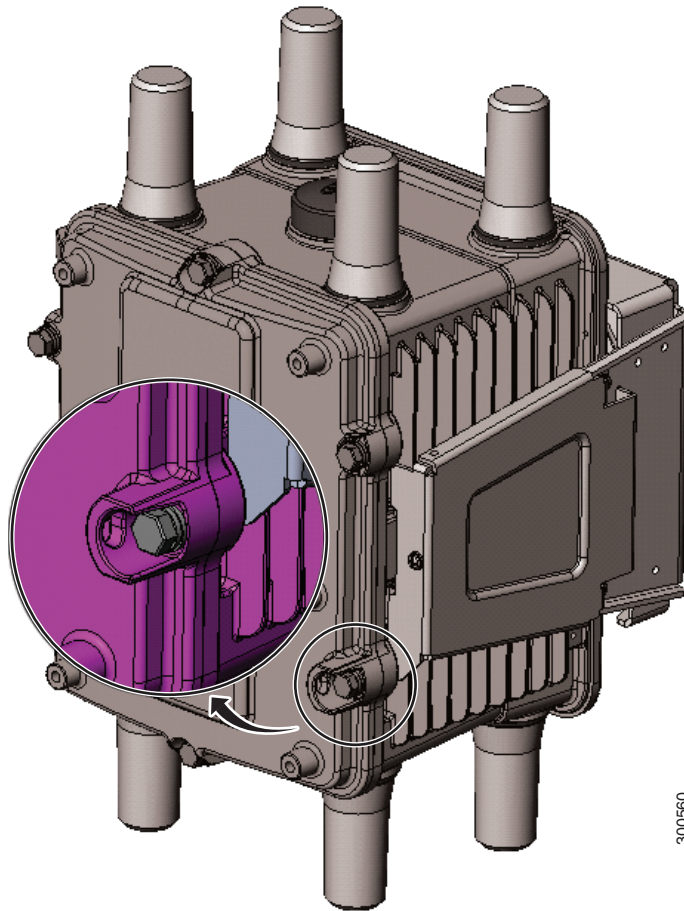

300560

Figure 60 External Lock Applied to the Door Lock Post

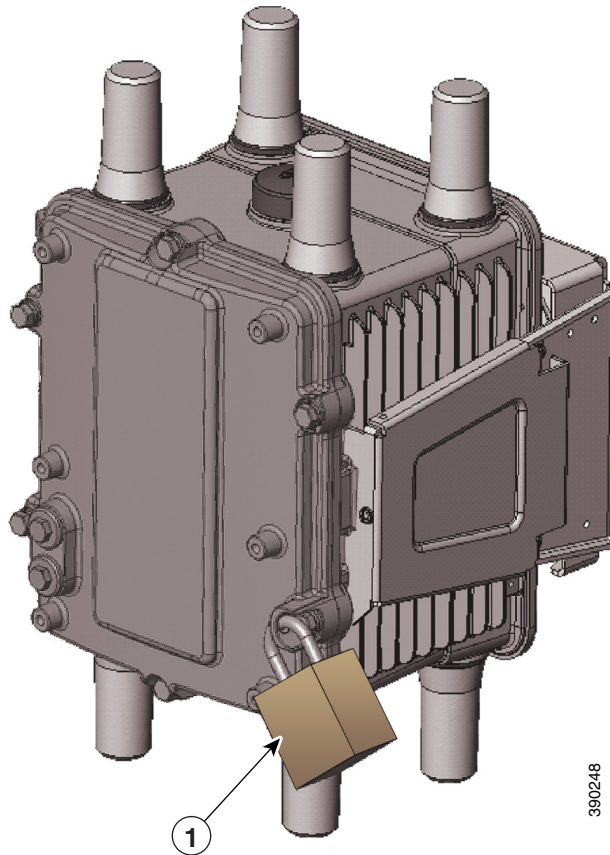

- 1 External lock

Note: The lock post supports a lock with a shank diameter of up to 5/16 inches (such as Master Lock part number 176).

Mounting Bracket Security Panel

The router door secures an optional security panel that you can install to prevent unauthorized users from removing the router from the mounting bracket, and to prevent unauthorized access to the SD card slot.

The security panel is shipped with the Mounting Bracket Kit.

For security panel details and installation instructions, see [Mounting the Router, page 45. on page 45](#)



Installing the Router

This section presents installation instructions for the Cisco 1240 Connected Grid Router (CGR 1240 or router). The procedures you follow depend on your network environment and requirements.

These topics are discussed:

- [Before Installing, page 85](#)
- [Related Information, page 86](#)
- [Basic Hardware Installation, page 86](#)
- [Additional Router Connections, page 95](#)
- [Installing Modules and Antennas, page 105](#)

Before Installing

Read the safety warnings in this section and [Installation Safety and Site Preparation, page 3](#) before beginning the installation procedures.

Prepare the Installation Site

These procedures assume that the installation site is prepared according to the information in [Installation Safety and Site Preparation, page 3](#).

Preventing Electrostatic Discharge Damage

Many of these components are sensitive to electrostatic discharge (ESD) damage, which can occur when electronic cards or components are handled improperly, results in complete or intermittent failures.

To prevent ESD damage, follow these guidelines:

- Always use an ESD wrist or ankle strap and ensure that it makes good skin contact.
- Connect the equipment end of the strap to an unfinished chassis surface.
- Place any removed memory card on an antistatic surface or in a static shielding bag. If the card will be returned to the factory, immediately place it in a static shielding bag.
- Avoid contact between the card and clothing. The wrist strap protects the card from ESD voltages on the body only; ESD voltages on clothing can still cause damage.
- Do not remove the wrist strap until the installation is complete.

Cabling Guidelines

Follow these guidelines for using cables with the router:

- Position cables so that they do not place strain on the router connectors.
- Organize cables into bundles when necessary to avoid intertwining.
- Inspect cables to ensure adequate routing and bend radius.
- Install cable ties that comply with your site requirements.

Related Information

This section describes installation procedures. For detailed, technical information about the router hardware, including connector and cable descriptions, specifications, and pinouts, see:

- [Router Hardware Description, page 9](#) describes all aspects of the router hardware, including internal and external features and connectors.
- [Connector and Cable Specifications, page 195](#) lists pinouts for the router connectors and cables.

Basic Hardware Installation

This section describes basis router installation steps. This is the minimum configuration required for the router to power up and begin operating on the backhaul network.

The steps in this section require that AC power and Ethernet network connections are available at the installation location, as described in [Power Guidelines and Requirements, page 6](#) and [Preparing for Network Connections, page 6](#).

The tasks in this section include:

- [Connect to the Ethernet Backhaul Network, page 86](#)
- [Connecting to AC Power, page 87](#)

Connect to the Ethernet Backhaul Network

The available Ethernet connection must meet the requirements described in [Installation Safety and Site Preparation, page 3](#).

Note: The external connector described in this section is connected to one of the Ethernet ports inside the router chassis. The internal port used depends on the router hardware configuration. If you are connecting the external Ethernet connector to an internal Ethernet port for the first time, Cisco recommends you connect it to the ETH 2/5 port.

1. Remove the cover from the external Ethernet connector.
2. Connect the local Ethernet cable to the router exterior Ethernet connector on the base of the router ([Figure 61 on page 87](#)).
3. Tighten the cable coupling ring (shown in [Figure 62 on page 87](#)) over the exterior router Ethernet connector to ensure an adequate seal over the connector.

Figure 61 External Ethernet Connector

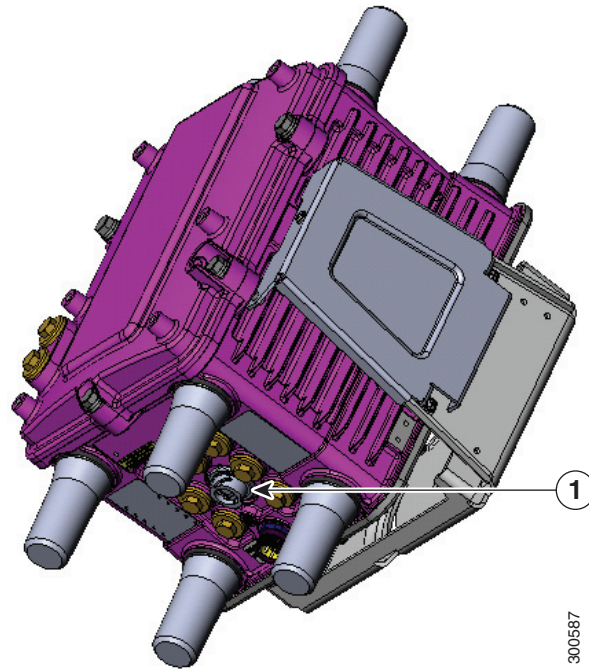

Item	Description
1	External Ethernet connector

Figure 62 Ethernet Cable with Coupling Ring



Connecting to AC Power

When connecting the router to AC power, you must ensure that the following conditions are met:

- AC power can be readily and conveniently removed from the router. The power should not be removed by disconnecting the AC power connector on the unit. It should be removed by disabling AC power at the power circuit.

Warning: The plug-socket combination must be accessible at all times, because it serves as the main disconnecting device. Statement 1019

Caution: Before connecting or disconnecting the power cord, remove AC power from the power cord using a suitable service disconnect.

- Protect AC power plugs and AC receptacles from water and other outdoor elements. You can use a UL-listed waterproofing enclosure suitable for covering the AC receptacle and AC power plug that supplies power to the unit, as described in Article 406 of the National Electric Code (NEC).
- When you install the unit outdoors, or in a wet or damp location, the AC branch circuit that powers the unit should have ground fault protection (GFCI), as required by Article 210 of the NEC.
- If the power cord goes through a metal cover, a bushing should be installed to prevent fraying of the cord. When using a strain relief bushing, you should follow these recommendations:
 - Use properly sized parts
 - Use bushings that are safety certified
 - Use parts that are suitable for outdoor installation
- Ensure that the user-supplied AC power plug is certified for outdoor use and has a minimum IP67 rating.

The topics in this section include:

- [AC Power Cable, page 88](#)
- [Connect to AC Power, page 89](#)

AC Power Cable

The router supports the Cisco AC power cable that is shipped with the unit. One end of the cable has the router AC power connector; the other end is unfinished and you must provide and attach an AC power plug, or terminate the cable at your installation site. The AC power plug or termination method you use depends on the power source, such as a junction box, at your site.

If you attach an AC power plug:

- Use a plug that complies with local and national electrical codes.
- Verify the connection between the cable and plug is weatherproof.

You might have to cut the cable if a specific cable length is needed for your installation.

Caution: Ensure that the power source is OFF before connecting or disconnecting the power cord wires from the power source.

Caution: To attach the appropriate connector to the AC power cable, follow the manual or other instructions provided by the electrical equipment vendor, ensuring that you comply with the electrical codes for your installation location.

Figure 63 Router AC Power Cable (Router Connector End)

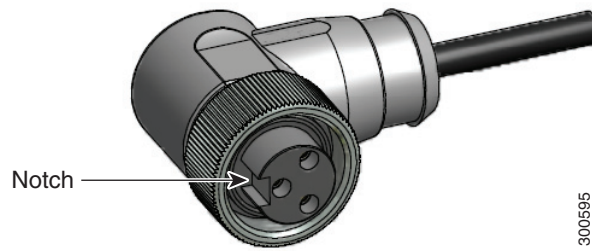

Connect to AC Power

To connect the router AC connector ([Figure 64 on page 90](#)) to an AC power source:

Caution: When connecting the router AC power connector, always connect the router end of the cable first. When removing the AC power connector, always disconnect the router end of the cable last.

1. Verify that the unit is grounded as described in [Mounting the Router, page 45](#).
2. Verify that the SD flash memory module is installed correctly as described in [Using the SD Flash Memory Module, page 133](#).
3. Turn off power to the AC power source at the designated circuits.
4. Align the notch in the AC power cable connector ([Figure 65 on page 90](#)) with the key in the router AC power connector, then push the cable connector into the router connector. When the cable connector is fully seated, rotate the cable connector ring clockwise until hand-tight.
5. Confirm the router antennas are connected to the router before you apply power to the router.
6. Connect the other end of the AC power cable to the power source, using the instructions that came with the connecting device.
7. Turn on AC power at the designated circuits.

The router powers on and boots the software image.

Figure 64 Router AC Connector

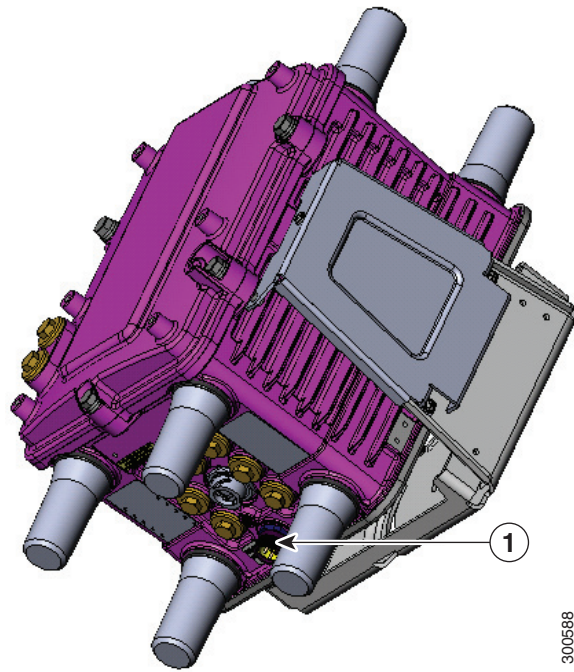

Item	Description
1	AC power connector

Figure 65 AC Connector Notch

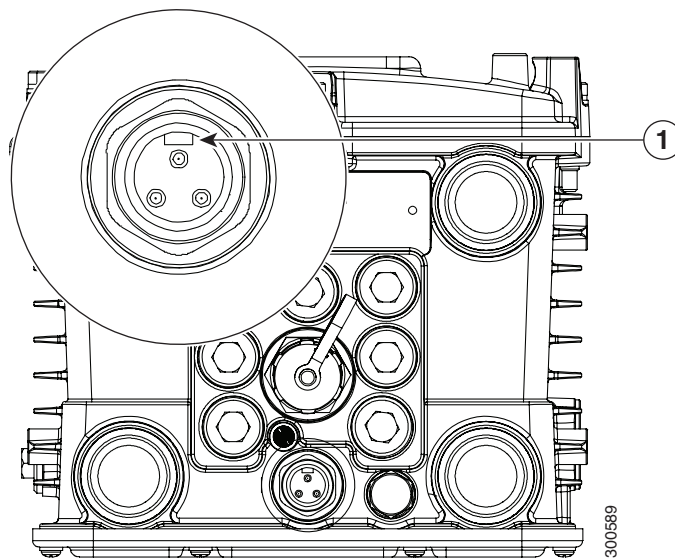

Item	Description
1	AC connector notch

Power and Reset Buttons

There are two reset buttons inside the router chassis. See [Figure 16 on page 31](#) for button locations. These buttons are used to reset the router power and software configuration. They are not used to power the router on and off; the router powers on immediately when it is connected to an AC power source.

Caution: When you use the CONFIG Reset button to restore the router to the factory default software configuration, the current software configuration is permanently deleted from the router.

- **CONFIG Reset**—Press the CONFIG Reset button for at least 5 seconds to return the router software configuration to the factory default, and power cycle the router. Power cycling the router turns the router off, then immediately back on. The router will temporarily stop operating on the network during the power cycle, then resume operating when the power cycle process is complete.
- **PWR RESET**—Press the PWR RESET button for at least 5 seconds to power cycle the router. Power cycling the router turns the router off, then immediately back on. The router will temporarily stop operating on the network during the power cycle, then resume operating when power cycle process is complete.

The topics in this section include:

- [Accessing the Buttons, page 91](#)
- [Related Information, page 91](#)

Accessing the Buttons

You must provide a non-metallic pin or other thin metal tool no larger than 3/16 inches in diameter to access and press these buttons.

Related Information

For detailed instructions for opening chassis door, see .

Verify the Router Basic Installation

After you connect the router to the network and power on the router, verify the router is correctly installed by performing the verification tasks described in this section. The tasks include:

- [Checking the System \(SYS\) LED, page 92](#)
- [Using the show interface Command, page 92](#)

Checking the System (SYS) LED

To verify that the router has been successfully installed, check the System (SYS) LED on the router base (Figure 66 on page 92). As the router starts up, the SYS LED will show these states:

Sequence	State	Description
1	Yellow	System is starting up or power cycling, and loading system software.
2	Green blinking	The system is starting up or power cycling, and loading system software, including BIOS and operating system
3	Green solid	Normal system operating status.
Alternate states	Amber	System receiving power but there is an error condition.
	Off	System not receiving power.

Figure 66 System (SYS) LED

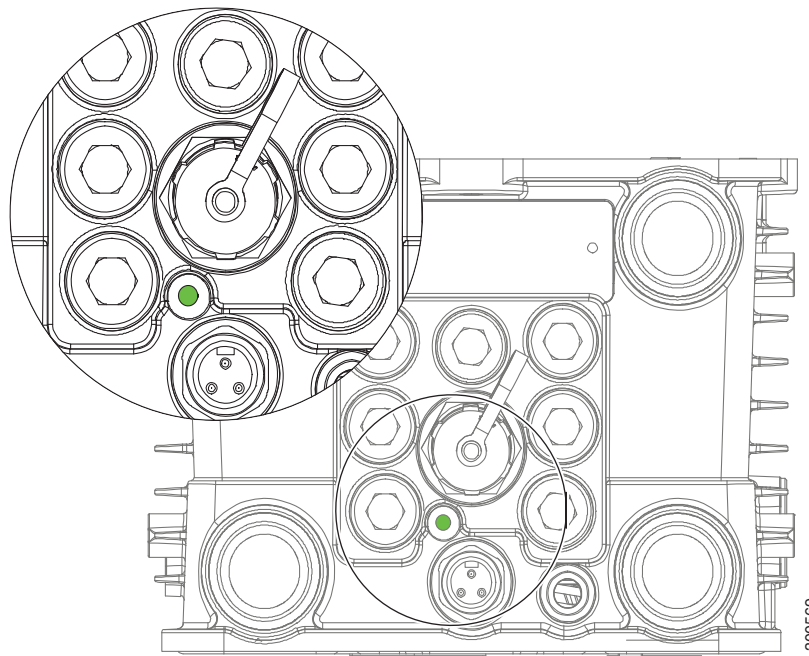

Using the show interface Command

To verify that the router has been successfully installed and connected to the network, use the **show interface** command to confirm that the router Ethernet interface is up. Two examples are provided:

- [Example: show interface Command Output for Cisco CG-OS, page 92](#)
- [Example: show interface Command Output for Cisco IOS, page 93](#)

Example: show interface Command Output for Cisco CG-OS

The output from the show interface command shows that the router Ethernet interface is up in the first line of the command output.

```
CGR1240> show interface
```

```
Ethernet0 is up, line protocol is up
```

```

Hardware is Cisco, address is 0019.076c.1a78 (bia 0019.076c.1a78)
Internet address is 192.0.2.111/23
MTU 1500 bytes, BW 10000 Kbit, DLY 1000 usec, rely 255/255, load 1/255
Encapsulation ARPA, loopback not set, keepalive set (10 sec)
ARP type: ARPA, ARP Timeout 04:00:00
Last input 00:00:00, output 00:00:00, output hang never
Last clearing of "show interface" counters never
Queueing strategy: fifo
Output queue 0/40, 0 drops; input queue 5/75, 32 drops
5 minute input rate 10000 bits/sec, 27 packets/sec
5 minute output rate 10000 bits/sec, 26 packets/sec
 16076431 packets input, 1280716531 bytes, 27 no buffer
  Received 1809290 broadcasts, 0 runts, 0 giants
  1105 input errors, 0 CRC, 0 frame, 0 overrun, 1105 ignored, 0 abort
  0 input packets with dribble condition detected
 16196175 packets output, 1011044938 bytes, 0 underruns
  19 output errors, 184 collisions, 3 interface resets
  0 babbles, 0 late collision, 1474 deferred
  19 lost carrier, 0 no carrier
  0 output buffer failures, 0 output buffers swapped out
Serial0 is administratively down, line protocol is down
Hardware is HD64570
MTU 1500 bytes, BW 1544 Kbit, DLY 20000 usec, rely 255/255, load 1/255
Encapsulation HDLC, loopback not set, keepalive set (10 sec)
Last input never, output never, output hang never
Last clearing of "show interface" counters never
Input queue: 0/75/0 (size/max/drops); Total output drops: 0
Queueing strategy: weighted fair
Output queue: 0/64/0 (size/threshold/drops)
  Conversations 0/0 (active/max active)
  Reserved Conversations 0/0 (allocated/max allocated)
5 minute input rate 0 bits/sec, 0 packets/sec
5 minute output rate 0 bits/sec, 0 packets/sec
  0 packets input, 0 bytes, 0 no buffer
  Received 0 broadcasts, 0 runts, 0 giants
  0 input errors, 0 CRC, 0 frame, 0 overrun, 0 ignored, 0 abort
  0 packets output, 0 bytes, 0 underruns
  0 output errors, 0 collisions, 1 interface resets
  0 output buffer failures, 0 output buffers swapped out
  0 carrier transitions
DCD=down DSR=down DTR=down RTS=down CTS=down

```

For more information about using the **show interface** command, see the router configuration guide on Cisco.com, at: www.cisco.com/go/cgr1000-docs.

Example: show interface Command Output for Cisco IOS

The output from the show interface command shows that the router Ethernet interface is up in the first line of the command output.

```

GigabitEthernet0/1 is up, line protocol is up
Hardware is iGbE, address is 0022.bdec.f0f9 (bia 0022.bdec.f0f9)
Internet address is 192.168.1.254/24
MTU 1500 bytes, BW 1000000 Kbit/sec, DLY 10 usec,
  reliability 255/255, txload 1/255, rxload 1/255
Encapsulation ARPA, loopback not set
Keepalive set (10 sec)
Auto Duplex, Auto Speed, media type is internal
output flow-control is unsupported, input flow-control is unsupported
ARP type: ARPA, ARP Timeout 04:00:00
Last input 00:06:39, output 00:00:06, output hang never
Last clearing of "show interface" counters never
Input queue: 0/75/0/0 (size/max/drops/flushes); Total output drops: 0

```

```
Queueing strategy: fifo
Output queue: 0/40 (size/max)
5 minute input rate 0 bits/sec, 0 packets/sec
5 minute output rate 0 bits/sec, 0 packets/sec
  8579 packets input, 612922 bytes, 0 no buffer
  Received 994 broadcasts (0 IP multicasts)
  0 runts, 0 giants, 0 throttles
  0 input errors, 0 CRC, 0 frame, 0 overrun, 0 ignored
  0 watchdog, 497 multicast, 0 pause input
  58519 packets output, 6541254 bytes, 0 underruns
  0 output errors, 0 collisions, 0 interface resets
  0 unknown protocol drops
  0 babbles, 0 late collision, 0 deferred
  1 lost carrier, 0 no carrier, 0 pause output
  0 output buffer failures, 0 output buffers swapped out
Dot11Radio2/1 is administratively down, line protocol is down
Hardware is 802.11N 2.4GHz Radio, address is 5cda.d4ad.092a (bia 5cda.d4ad.092a)
MTU 1500 bytes, BW 72000 Kbit/sec, DLY 0 usec,
  reliability 0/255, txload 1/255, rxload 1/255
Encapsulation ARPA, loopback not set
Keepalive set (10 sec)
ARP type: ARPA, ARP Timeout 04:00:00
Last input never, output never, output hang never
Last clearing of "show interface" counters never
Input queue: 0/75/0/0 (size/max/drops/flushes); Total output drops: 0
Queueing strategy: fifo
Output queue: 0/30 (size/max)
5 minute input rate 0 bits/sec, 0 packets/sec
5 minute output rate 0 bits/sec, 0 packets/sec
  0 packets input, 0 bytes, 0 no buffer
  Received 0 broadcasts (0 IP multicasts)
  0 runts, 0 giants, 0 throttles
  0 input errors, 0 CRC, 0 frame, 0 overrun, 0 ignored
  0 input packets with dribble condition detected
  0 packets output, 0 bytes, 0 underruns
  0 output errors, 0 collisions, 0 interface resets
  0 unknown protocol drops
  0 babbles, 0 late collision, 0 deferred
  0 lost carrier, 0 no carrier
  0 output buffer failures, 0 output buffers swapped out
FastEthernet2/3 is down, line protocol is down
Hardware is Fast Ethernet, address is 0022.bdec.f0f3 (bia 0022.bdec.f0f3)
MTU 1500 bytes, BW 100000 Kbit/sec, DLY 100 usec,
  reliability 255/255, txload 1/255, rxload 1/255
Encapsulation ARPA, loopback not set
Keepalive set (10 sec)
Auto-duplex, Auto-speed
ARP type: ARPA, ARP Timeout 04:00:00
Last input never, output never, output hang never
Last clearing of "show interface" counters never
Input queue: 0/75/0/0 (size/max/drops/flushes); Total output drops: 0
Queueing strategy: fifo
Output queue: 0/40 (size/max)
5 minute input rate 0 bits/sec, 0 packets/sec
5 minute output rate 0 bits/sec, 0 packets/sec
  0 packets input, 0 bytes, 0 no buffer
  Received 0 broadcasts (0 multicasts)
  0 runts, 0 giants, 0 throttles
  0 input errors, 0 CRC, 0 frame, 0 overrun, 0 ignored
  0 watchdog, 0 multicast, 0 pause input
  0 input packets with dribble condition detected
  0 packets output, 0 bytes, 0 underruns
  0 output errors, 0 collisions, 2 interface resets
  0 unknown protocol drops
  0 babbles, 0 late collision, 0 deferred
```

```
0 lost carrier, 0 no carrier, 0 pause output
0 output buffer failures, 0 output buffers swapped out
```

For more information about using the **show interface** command, see the router configuration guide on Cisco.com, at: www.cisco.com/go/cgr1000-docs.

Additional Router Connections

This section provides information about making other, additional router cable connections. Follow the procedures in this section based on your network configuration and requirements. This section contains these procedures:

- [External Connections and Chassis Cable Ports, page 95](#)
- [Using Cable Glands, page 96](#)
- [Connecting the Console Port, page 100](#)
- [Connecting the Serial Port, page 101](#)
- [Connecting the USB Ports, page 102](#)
- [Connecting the SFP Ports, page 103](#)
- [Connecting the Ethernet Ports, page 104](#)
- [Connecting the Alarm Port, page 104](#)
- [Connecting the IRIG-B Port, page 105](#)

External Connections and Chassis Cable Ports

When connecting the router internal ports to external cables or exterior devices, you must thread the router cables through the chassis cable ports designated for this purpose. Some chassis ports are reserved for specific cables and remaining ports can be used based on your network configuration and cabling requirements.

There are nine cable ports on the chassis base and two ports on the chassis door ([Figure 67 on page 96](#)). Some ports are reserved for a specific cables types, as indicated [Figure 67 on page 96](#).

Caution: When you make router cable connections through these ports, you must use cable glands as described in [Using Cable Glands, page 96](#), to protect the router interior from environmental elements, including moisture, heat, cold, and dust. Failure to use cable glands with the chassis cable ports can result in damage to the router.

Note: We recommend that you cover the ports mentioned in this section with a PG 13.5 plug when they are not in use. Ensure that you torque the PG 13.5 plug to 6 to 7 foot-pounds.

Figure 67 Chassis Cable Ports—For Cabling to External Connectors or Devices

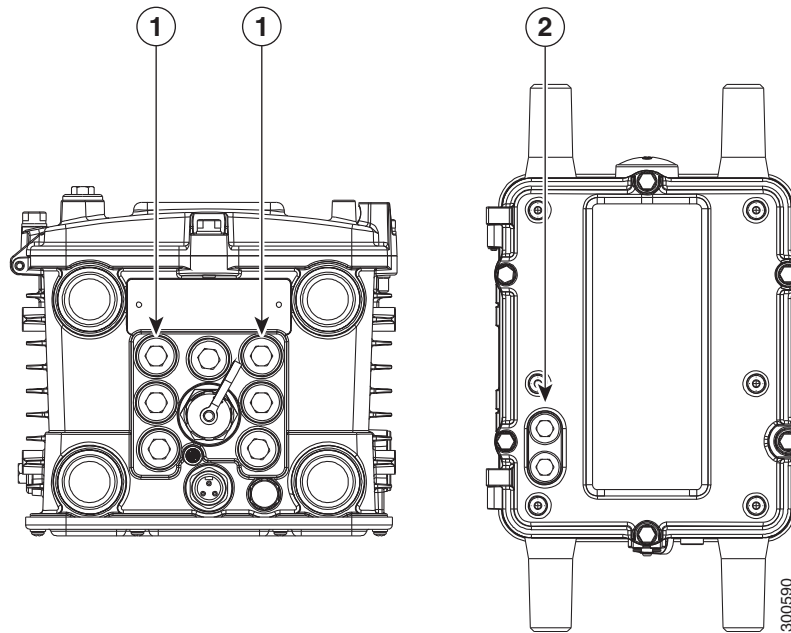

Item Description

- 1 These two ports on the router base are reserved for SFP module cables. One of these ports is shown with the PG 13.5 port plug that must be used when the port is not in use. Ensure that you torque the PG 13.5 plug to 6 to 7 foot-pounds.
- 2 These two ports on the router door are reserved for non-Cisco module cables.

Using Cable Glands

This section describes how to use cable glands with router cables that are threaded through the chassis cable ports described in [External Connections and Chassis Cable Ports, page 95](#).

Caution: The cable glands must be used for all cables that are threaded through the router chassis cable ports to prevent exposing the router interior to environmental elements.

Ordering Cisco Cable Glands

You can order a cable gland kit from Cisco using the model number CGR-IP67GLAND. Each kit contains one cable gland. See [Router Hardware Description, page 9](#).

Tools You Supply

You must supply:

- 13-mm box-end wrench or socket set to remove port seals from the router
- 15/16-inch (24 mm) open-end wrench

Cable Glands Description

Figure 68 Cable Glands, Assembled



Figure 69 Cable Gland Components

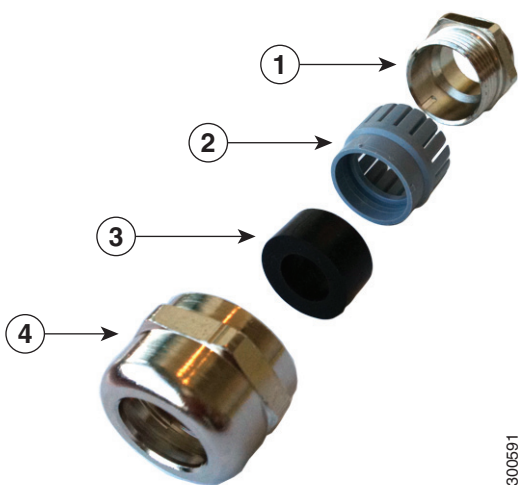

Item	Name	Description
1	Adapter	Connects directly to the chassis cable port on the router.
2	Grommet	Secures the split gasket over the cable.
3	Split gasket	Fits over the cable and creates an liquid-tight seal inside the glands.
4	Cap	Fits over gasket-and-cable assembly and connects it to the chassis cable port.

Cable Requirements

Cables used with the cable glands should meet the following criteria:

- Outdoor-rated
- UV-stabilized
- Diameter of 0.20-0.35 inches (5.08-8.89 mm)

Caution: Cables must be a minimum of 0.20 in. in diameter to create an adequate seal within the cable glands. Using smaller cables could result in an inadequate seal and therefore expose the router interior to environmental elements.

Cable Glands Installation Steps

Follow these steps for every cable that you will connect through the chassis cable ports on the router. Step 4 and Step 5 can be done ahead of time and the prepared cable gland assembly can be transported to the router installation site.

The cable glands components referred to in this section are shown in [Figure 69 on page 97](#).

Note : [Figure 71 on page 100](#) shows an Ethernet cable but the steps are the same for all cable types.

1. Verify the cable you are using meets the requirements described in [Cable Requirements, page 97](#).
2. Remove the port plug from the port on the router. Use the 13-mm wrench if needed.

The router is shipped with ports plugs in unused ports. [Figure 67 on page 96](#) illustrates a port plug.
3. Use your hands to attach the cable glands adapter (item 1 in [Figure 69 on page 97](#)) into the chassis cable port on the router ([Figure 70 on page 99](#)).
4. Thread the following cable glands components over the cable in this order ([Figure 71 on page 100](#)):
 - Cap
 - Split gasket
 - Grommet
5. Slide the split gasket along the cable and into the grommet, pressing firmly to ensure the gasket is completely seated in the grommet.
6. Thread the connector-end of the cable through the router port and insert it into the corresponding router connector.
7. Align and press the grommet-gasket assembly into the adapter.
8. Slide the cap along the cable, over the grommet, and then onto the adapter.
9. Hand-tighten the cap, and then use the open-end wrench to tighten it until the split gasket seals around the cable (6 to 7 foot-pounds of torque). There should be 5-10 pounds of cable pull support.

Figure 70 Attach Adapter to Chassis Cable Port on Router Base

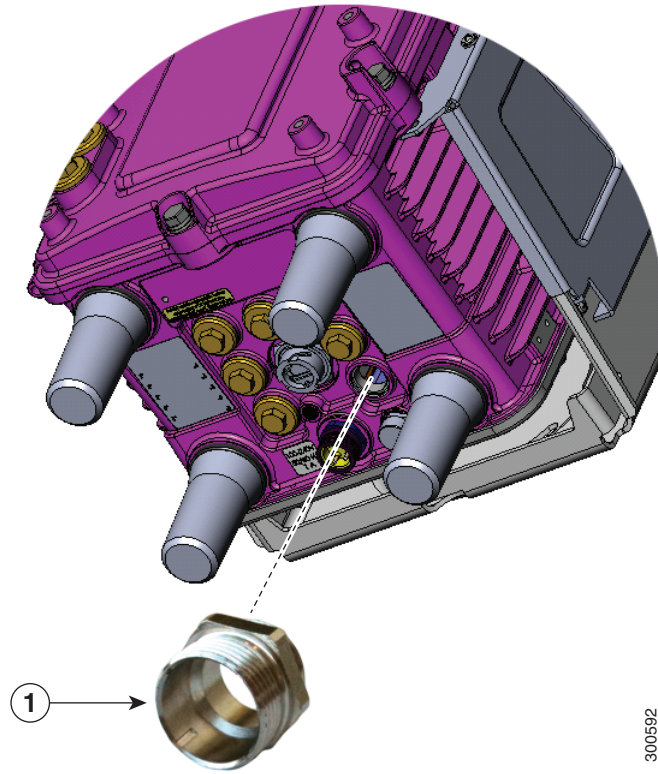

300592

Item	Description
1	Attach cable glands adapter to any compatible cable port on the router.

Figure 71 Cable Glands Components Threaded on Cable

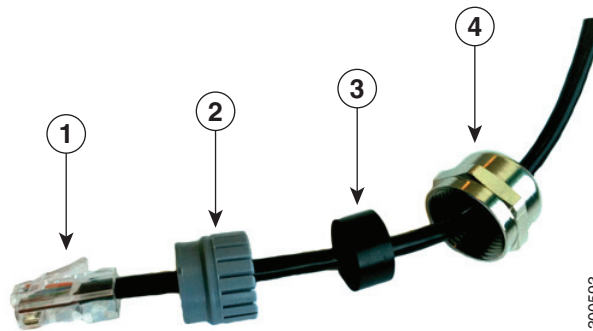

Item	Description
1	Cable connector (to router)
2	Grommet
3	Split gasket
4	Cap

Connecting the Console Port

See [Figure 72 on page 101](#) for the console port location.

About

To configure the router through the Cisco IOS command-line interface (CLI), you must establish a connection between the router console port and either a terminal or a PC. The console port is located on the router exterior and is labeled **CON**.

Use this port to connect a PC terminal, enabling you to log directly into the router system software to perform configuration or other commands.

Caution: The console port does not support cable glands. When a cable is connected to this port, the router interior is exposed to environmental elements, which can damage the port and the router interior. This port should be exposed only during terminal sessions, when a cable is connected to the port. This port should never be left unattended when in use. When not in use, cover the console port with a PG 13.5 plug. Ensure that you torque the PG 13.5 plug to 6-7 ft-lbs.

Figure 72 Console Port Location

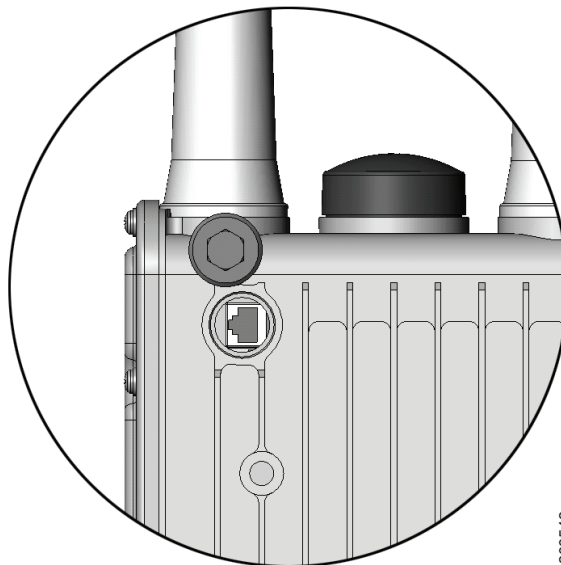

Connecting

This section describes how to connect a PC terminal to the console port.

Your router kit includes a console cable with an RJ-45 connector on one end, and a DB-9 connector on the other end.

- When a terminal is connected to the console port, you can connect directly to the router and configure it. You can connect a PC terminal to this port while the router is operating normally.
- To connect a PC terminal to the router, you must provide one of the following adapters, depending on the device port: RJ-45-to-DB-25 female DTE adapter, RJ-45-to-DB-9 female DTE adapter (labeled TERMINAL), or USB-to-DB-9 adapter.
- To remove the RJ-45 cable from the console port, compress the retention latch on the RJ-45 connector while removing the cable from the port. Use any small, flat, non-metallic tool to press the latch while pulling the cable from the port.

To connect a PC or PC terminal to the console port:

1. Connect the RJ-45 connector on the console cable to the console port on the router.
2. If your device requires a DB-9 adapter, connect the adapter you provide to the DB-9 connector on the cable.
3. Connect the adapter-end or DB-9 connector-end of the console cable to your terminal or PC.

Related Information

- For information about starting a terminal session over the console port with Microsoft Windows, Mac OS X, or Linux, see [Starting a Router Terminal Session, page 191](#).
- For more information about this port, see [Router Hardware Description, page 9](#).

Connecting the Serial Port

See [Figure 20 on page 37](#) for the router serial port locations.

Before you connect a device to the router serial port, you need to know the following:

- Type of device, data terminal equipment (DTE) or data communications equipment (DCE), you are connecting to the synchronous serial interface
- Type of connector, male or female, required to connect to the device
- Signaling standard required by the device

Connecting

- You must provide or purchase separately the correct serial cable. The cable does not ship with the router. Contact your Cisco reseller to purchase the correct cable from Cisco.
- The router RS232 interface operates as a DCE; any connection to this interface must be as a DTE.
- If you use a DB-9 connector for the serial ports, you must provide an adapter.
- You can connect a device to this port while the router is operating normally.
- The serial ports are labeled **SER 1/1** and **SER 1/2**.
- When connecting the serial ports to devices, you must use cable glands and thread cables through the chassis cable ports on the router. See [External Connections and Chassis Cable Ports, page 95](#).

Related Information

For more information about this port, including supported standards and signaling, see [Router Hardware Description, page 9](#).

Connecting the USB Ports

See [Figure 22 on page 40](#) for USB port locations.

Note: Currently not supported. This hardware feature will be supported in a future software release.

About

You can connect up to two optional USB devices to the router USB ports, which will provide power to the USB devices. You can also connect USB devices that are powered by an external source, such as an AC adapter or batteries.

Connecting

- You can connect devices to these ports while the router is operating normally.
- The USB ports are labeled **1** and **2** (with a USB icon).
- Depending on the USB devices you connect to these ports, you might require a USB extension cable to connect devices to these ports.
- To prevent connected USB devices from being stolen or accidentally removed, secure any connected USB device with a locking mechanism designed for this purpose.
- When connecting to external USB devices, you must use cable glands and thread USB cables through the chassis cable ports on the router. See [External Connections and Chassis Cable Ports, page 95](#).

Related Information

For information about these ports, including supported USB standards and power output, see [Router Hardware Description, page 9](#).

Connecting the SFP Ports

See [Figure 18 on page 34](#) for the SFP port locations.

Small Form-Factor Pluggable (SFP) modules are transceiver devices that plug into the router SFP connectors. The transceiver connects the electrical circuitry of the module with the optical network.

The SFP module used on each port must match the wavelength specifications on the other end of the cable, and the cable must not exceed the stipulated cable length for reliable communications.

Use only Cisco SFP transceiver modules with the router. Each SFP transceiver module supports the Cisco Quality Identification (ID) feature which allows a Cisco switch or router to identify and validate that the transceiver module is certified and tested by Cisco.

Warning: Class 1 laser product. Statement 1008

Caution: Do not remove the dust plugs from the fiber-optic SFP module port or the rubber caps from the fiber-optic cable until you are ready to connect the cable. The plugs and caps protect the SFP module ports and cables from contamination and ambient light.

Caution: We recommend that you not install or remove the SFP module while the fiber-optic cable is attached to it because of the potential damage to the cables, to the cable connector, or to the optical interfaces in the SFP module. Disconnect the cable before you remove or install an SFP module.

Materials and Tools You Supply

You must provide these tools and materials to install the SFP transceiver module:

- Wrist strap or other personal grounding device to prevent ESD occurrences.
- Antistatic mat or antistatic foam to set the transceiver on.
- Fiber-optic end-face cleaning tools and inspection equipment. For complete information on inspecting and cleaning fiber-optic connections, see the white-paper document at this URL:

http://www.cisco.com/en/US/tech/tk482/tk876/technologies_white_paper09186a0080254eba.shtml

Connecting

You can connect SFP modules to these ports while the router is operating normally. The SFP ports are labeled **ETH 1/2** and **ETH 2/2**.

When installing or removing SFP modules, observe these guidelines:

- Removing and installing an SFP module can shorten its useful life. Do not remove and insert any module more often than is absolutely necessary.
- To prevent ESD damage, follow your normal board and component handling procedures when connecting cables to the switch and other devices.

This section describes how to install SFP modules. SFP modules are inserted into the SFP ports shown in [Figure 22 on page 40](#).

1. Attach an ESD-preventive wrist strap to your wrist and to a bare metal surface.
2. For fiber-optic SFP modules, remove the dust plugs and store them in a clean location for reuse.
3. Position the SFP transceiver module in front of the socket opening, and insert the SFP into the socket until you feel the connector latch into place.
4. Remove the dust plugs from the network interface cable LC connectors.

-
5. Inspect and clean the LC connector's fiber-optic end-faces.
 6. Thread the SFP cable through the chassis cable ports that are reserved for the SFP cables ([Figure 67 on page 96](#)).

Note: You must use cable glands with the chassis cable ports on the router. See [External Connections and Chassis Cable Ports, page 95](#).

7. Attach the network interface cable connector to the SFP transceiver module.

Related Information

- For supported SFP modules, see [Router Hardware Description, page 9](#).
- For detailed information on connecting the SFP module cable to the network, see Cisco.com for the documentation for your SFP module.

Connecting the Ethernet Ports

See [n on page 31](#) for Ethernet port locations.

The router features four Fast Ethernet (FE) ports and two Gigabit Ethernet (GE) ports for connecting the router to an Ethernet network through a hub or switch.

Connecting

- One or two Ethernet cables are typically provided with the router. Additional cables and transceivers can be ordered from Cisco. For ordering information, contact customer service.
- When connecting cables to the Ethernet ports, you must use cable glands and thread cables through the chassis cable ports on the router. See [External Connections and Chassis Cable Ports, page 95](#).
- The GE ports (ETH 2/1 and ETH 2/2) have identical labels to the SFP ports because the SFP ports share physical ports with the GE ports. For detailed information about how to use these ports, see [Hot Swapping SFP Modules, page 34](#).

Warning: Do not work on the system or connect or disconnect cables during periods of lightning activity. Statement 1001

Related Information

[Router Hardware Description, page 9](#) includes detailed information about these ports, including:

- Specifications
- Standards
- Link to pinout information

Connecting the Alarm Port

See [Figure 14 on page 28](#) for the alarm port location.

Attach the alarm port to an alarm system to monitor software events and errors. The alarm port supports two alarm inputs and two alarm outputs.

The alarm-trigger setting determines when an alarm is sent to the attached alarm system.

Connecting

- You can connect this port while the router is operating normally.
- If you use an alarm system on your network, connect the alarm port to an alarm system, using an alarm cable that you provide.
- When connecting this port to an external alarm system, you must use cable glands and thread cables through the chassis cable ports on the router. See [External Connections and Chassis Cable Ports, page 95](#).

Related Information

[Router Hardware Description, page 9](#) includes detailed information about this port, including:

- Specifications
- Location on the router
- Link to pinout information

Connecting the IRIG-B Port

See [Figure 21 on page 39](#) for the IRIG-B port location.

Note: Currently not supported. This hardware feature will be supported in a future software release.

The IRIG-B port provides precise time data. The source of the time is the GPS to which the router is connected. This port provides time output only.

Connecting

- You can connect this port while the router is operating normally.
- You must provide the device and the cable for this connection.
- When connecting this port to an external device, you must use cable glands and thread cables through the chassis cable ports on the router. See [External Connections and Chassis Cable Ports, page 95](#).

Related Information

[Router Hardware Description, page 9](#) includes detailed information about this port, including:

- Supported serial time code formats
- Location on the router

Installing Modules and Antennas

The router supports up to four Cisco Connected Grid modules. Each module requires one or two antennas, which are installed on or near the router. See [Connected Grid Modules, page 115](#) and [Antennas, page 121](#).





Powering Off the Router

This section presents instructions to completely power off the Cisco 1240 Connected Grid Router (CGR 1240 or router) and disable installed battery backup units (BBUs). The router must be completely powered off to perform certain tasks, including:

- Transporting the router to a new location
- Repairing or upgrading the router hardware
- Mounting the router

Perform the following tasks in this order:

1. [Verify Console or Terminal Access to the Router, page 107](#)
2. [Disable the Router BBU at the CLI, page 108](#)
3. [Disconnect Router AC Power, page 108](#)
4. [Disable the Router BBU at the CLI, page 108](#)
5. [Check SYS LED, page 109](#)

Verify Console or Terminal Access to the Router

Note: If the router does not have any installed BBUs, skip this section, and go to [Disconnect Router AC Power, page 108](#).

Note: The router can only be disabled by console or terminal access on routers using the Cisco CG-OS operating system. The BBU cannot be disabled by console or terminal access on routers using the Cisco IOS operating system.

Note: If you do not have console or terminal access to the router, you can disable the BBU by disconnecting the BBU harness cable. For more information, see [Disable the BBU by Disconnecting the BBU Harness Cable, page 108](#).

To disable the router BBU, you must have access to the router system software command-line interface (CLI). Start a console or terminal session with the router to access the system software CLI. You can connect to the router with a direct connection (using a cable) to the router console port, or over the router WiFi connection.

For more information about starting a console or terminal session with the router, see the following sections:

- [Starting a Router Terminal Session, page 191](#)
- [WiFi Default Settings, page 43](#)

For more information about disabling the router BBU at the CLI, go to [Disable the Router BBU at the CLI, page 108](#).

Using Connected Grid NMS

Depending on how your Connected Grid Network Management System (CG-NMS) software is configured, you may be able to disable the BBU over the network using CG-NMS. Check with the network administrator.

Disable the Router BBU at the CLI

Note: The router can only be disabled by console or terminal access on routers using the Cisco CG-OS operating system. The BBU cannot be disabled by console or terminal access on routers using the Cisco IOS operating system.

To completely power down a router with an installed BBU, use the **backup-battery inhibit discharge** EXEC command to disable the BBU.

Caution: Entering the **backup-battery inhibit discharge** command disables the BBU immediately. You are not prompted to confirm the command. If you enter this command when the router is operating on the network and powered by the BBU, the router will immediately power down and will no longer operate on the network.

This example shows how to disable the BBU with the system software CLI:

```
CGR1240# configure terminal
CGR1240# backup-battery inhibit discharge
```

- This command is active only when the BBU is discharging. If you enter this command when the router is receiving AC power, the CLI displays an error message.
- Use the **backup-battery un-inhibit discharge** EXEC command to reset the BBU to default behavior, which is to automatically begin discharging when the router is not receiving AC power.

Disconnect Router AC Power

To disconnect the router from AC power:

1. Disable power at the circuit or power supply to which the router AC power cable is connected.
2. Disconnect the router AC power cable from the AC power connector on base of the router enclosure.
3. Perform one of the following steps:
 - a. If the router has one or more BBUs installed, immediately disable the BBU as described in [Disable the Router BBU at the CLI, page 108](#) or [Disable the BBU by Disconnecting the BBU Harness Cable, page 108](#).
 - b. If the router does not have any installed BBUs, skip to [Check SYS LED, page 109](#).

For more information about the router power supply, see:

- [AC Power Supply, page 26](#)

Disable the BBU by Disconnecting the BBU Harness Cable

Disabling the BBU by disconnecting the BBU harness cable can be used when console or terminal access is not available and you cannot disable the BBU at the CLI.

Note: For routers using Cisco IOS, you must disable the BBU by using the IOS CLI and then disconnecting the BBU harness cable. You can only disable BBU by terminal or console access on routers using Cisco CG-OS.

To disable the BBU by disconnecting the BBU harness cable:

1. Confirm that the router AC power is disconnected.
2. Disconnect the BBU harness cable.

Check SYS LED

To confirm that the router is powered off, verify that the SYS LED is off. The SYS LED is on the bottom exterior of the router enclosure, as shown in [Figure 73 on page 109](#).

Figure 73 Router SYS LED

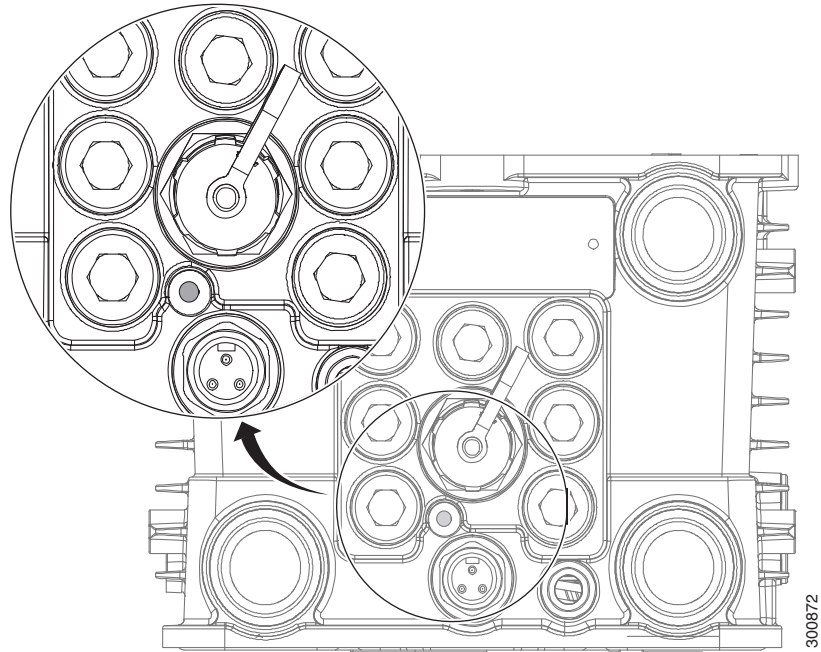





Unmounting the Router

This section describes the safety information, equipment, and procedures required to remove the Cisco 1240 Connected Grid Router (CGR 1240 or router) from a vertical pole.

These topics are discussed:

- [Materials and Tools You Supply, page 111](#)
- [Unmounting Instructions, page 111](#)
- [Transporting the Router, page 113](#)

Materials and Tools You Supply

- 1/2-inch (13-mm) socket wrench
- #2 Phillips-head screwdriver

Unmounting Instructions

To unmount the router on any supported pole type:

1. Power off the router by following instructions in [Powering Off the Router, page 107](#):
 - Disable AC power (see [Disconnect Router AC Power, page 108](#)).
 - Disable BBUs (see [Disable the Router BBU at the CLI, page 108](#) or [Disable the BBU by Disconnecting the BBU Harness Cable, page 108](#)).
2. Remove/disconnect any external cables (for example, the external Ethernet connector at base of unit).
3. Open the router door using the socket wrench and by following instructions in [Opening the Door, page 78](#).
4. Disconnect the internal cables, taking care to remove cable from cable glands.
5. Close the router door by following instructions in the [Closing the Door, page 78](#).

Note: Closing the door before transporting the router can prevent personal injury and damage to the unit.
6. Remove the ground wire located at the side of the router.
7. Remove the security panel from the unit (if one is installed, this is an optional part of the mounting bracket). For more information, see [Install the Optional Security Panel, page 64](#).

Figure 74 Location Security Panel Installed

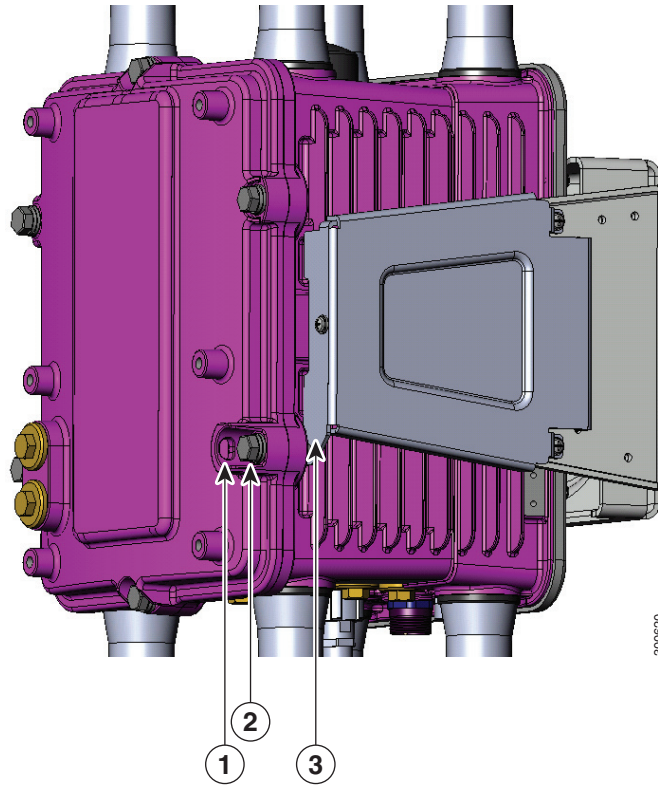

Item	Description
1	Router door
2	Captive bolt
3	Security panel

8. Remove 3 of the 4 bolts that attach the mounting bracket to the router. Do not remove the hinge bolt, which is the fourth bolt. Remove the equivalent bolts on the opposite side of the router.

Figure 75 Removing Bolts from Security Bracket

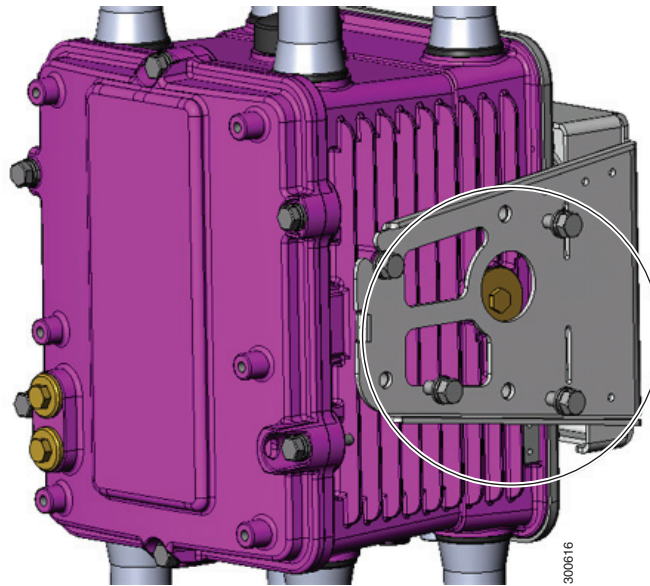

9. Loosen hinge bolts two complete turns (do not loosen so that the bolts are removed from chassis).
10. Remove the router from the bracket.

Transporting the Router

To transport the router:

1. Disconnect lightning arrestors that might be installed on the router.
2. Verify that all open chassis ports are sealed with the cable port seal plugs shipped with the router.





Connected Grid Modules

This section discusses how the Cisco 1240 Connected Grid Router (CGR 1240 or router) supports up to four Cisco Connected Grid modules that enable Neighborhood Area Network (NAN) connections from the router to field devices such as meters and Intelligent Electronic Devices (IEDs), and from the router to the central utility station or data management center.

These topics are discussed:

- [Installing or Replacing Modules, page 115](#)
- [Installing Modules in the Router, page 115](#)
- [Module Documentation, page 119](#)

Installing or Replacing Modules

The router supports up to four modules. Depending on the configuration, your router could arrive in the shipping container with all required modules already installed. However, you might need to install a module when you:

- Add modules to your current installation.
- Replace a faulty module.

Installing Modules in the Router

Installation Steps for Specific Modules

This section provides general instructions for installing modules in the router. For information specific to a particular module, refer to the module installation and configuration guides on Cisco.com, at: www.cisco.com/go/cg-modules.

Preparing to Install Modules

Before installing modules in the router, ensure that the following guidelines have been met:

Note: The Connected Grid modules support online insertion and removal (OIR).

- Verify that there is adequate airflow around the router. See [Installation Safety and Site Preparation, page 3](#).
- The ambient installation environment temperature must not exceed 140°F (60°C). When modules are installed in a closed assembly (such as inside the router), the temperature around it might be higher than normal room temperature.
- The installation environment humidity must not exceed 95% (non-condensing).
- The installation site altitude must be no higher than 10,000 feet.

-
- After replacing or installing a module in the router, you must update the label (on the router exterior) that lists the module types contained in the router. The label must list the FCC ID number and the IC Certification number for each module installed in the router.

Installation Warning Statements

This section includes the installation warning statements. Translations of these warning statements appear in the *Regulatory Compliance and Safety Information for Cisco Connected Grid Router 1000 Series Routers* documents on Cisco.com, at: www.cisco.com/go/cgr1000-docs.

Warning: Only trained and qualified personnel should be allowed to install, replace, or service this equipment. Statement 1030

Warning: To prevent the system from overheating, do not operate it in an area that exceeds the maximum recommended ambient temperature of 158° F (70° C). Statement 1047

Warning: To prevent airflow restriction, allow clearance around the ventilation openings to be at least: 1.75 in. (4.4 cm) Statement 1076

Installing and Removing Modules

The Connected Grid modules support OIR, and a module can be installed or removed while the router is online or offline. Online refers to power-on status; offline refers to power-off status.

This section provides general module installation steps and refers to additional documentation for detailed information:

- [Referenced Installation Documents, page 116](#)
- [Tools and Materials You Supply, page 116](#)
- [Module Installation Locations, page 117](#)
- [Installing a Module in an Offline Router, page 117](#)
- [Installing a Module in an Online Router, page 118](#)
- [Removing a Module from an Offline Router, page 119](#)
- [Removing a Module from an Online Router, page 119](#)

Referenced Installation Documents

The following documents are referenced in these installation procedures:

- [Connected Grid Antenna Installation Guide](#)—Located on Cisco.com at www.cisco.com/go/cg-modules
- [Connected Grid Modules Installation and Configuration Guides](#)—Located on Cisco.com at www.cisco.com/go/cg-modules
- [Cisco Connected Grid Device Manager Installation and User Guide](#) on Cisco.com at www.cisco.com/go/cgr1000-docs

Tools and Materials You Supply

You must provide the following tools to install and remove modules:

- #1 Phillips screwdriver

Module Installation Locations

To ensure support for all module types and allow convenient cabling, Cisco recommends the following installation location guidelines:

- Connected Grid modules and module slot compatibility are listed in [Table 22 on page 117](#) and illustrated in [Figure 76 on page 118](#).
- Module antenna installation locations are illustrated in [Antenna Installation Location, page 128](#).

Table 22 Connected Grid Module Locations in the CGR 1240 Router

Connected Grid Module Type	Cisco CG-OS Installation Slot	Cisco IOS Installation Slot
3G Cellular	Slot 3	Slot 3
4G LTE	Slots 3 or 6	Slots 3 or 6
WPAN/CG-Mesh	Slot 4	Slot 4
WPAN/RFLAN	Slot 4	N/A
WiMAX	Slot 6	Slot 6
Compute	Slot 5 (Slot 6 must remain empty to dissipate heat)	Slot 5 (Slot 6 must remain empty to dissipate heat)

Installing a Module in an Offline Router

Note: This is a general installation procedure for installing modules in the chassis of an offline router. For hardware installation and software configuration steps that are specific to your module, see the installation and configuration guide for the module, at: www.cisco.com/go/cg-modules.

To install a module in an available slot of an offline router:

1. Disconnect the router from AC power and disable any installed battery backup units by following the steps in [Powering Off the Router, page 107](#).
2. Open the chassis door by following the steps in [Opening and Closing the Router Chassis, page 75](#).
3. Use the screwdriver to remove the faceplate that covers the empty module slot.
4. Align the module edge with the slot edge guide and insert the module in the router module slot until fully seated in the PCI connector ([Figure 76 on page 118](#)).
5. Use the screwdriver to tighten the captive module mounting screws (two per module) into the connectors on the router front panel. Torque to 10 to 12 inch-pounds.

6. Attach any required cables to the module. This step is specific to the module type.

Note: Refer to the installation and configuration guide for the module, at www.cisco.com/go/cg-modules.

Note: Cut the excess tie material away holding the cables in place.

7. Close the router door, following the steps in [Opening and Closing the Router Chassis, page 75](#).
8. Connect the router to AC power and to the network, following the steps in [Installing the Router, page 85](#).
9. Re-enable the BBU using the commands in [Related Commands, page 160](#).

Figure 76 Insert Modules into Router

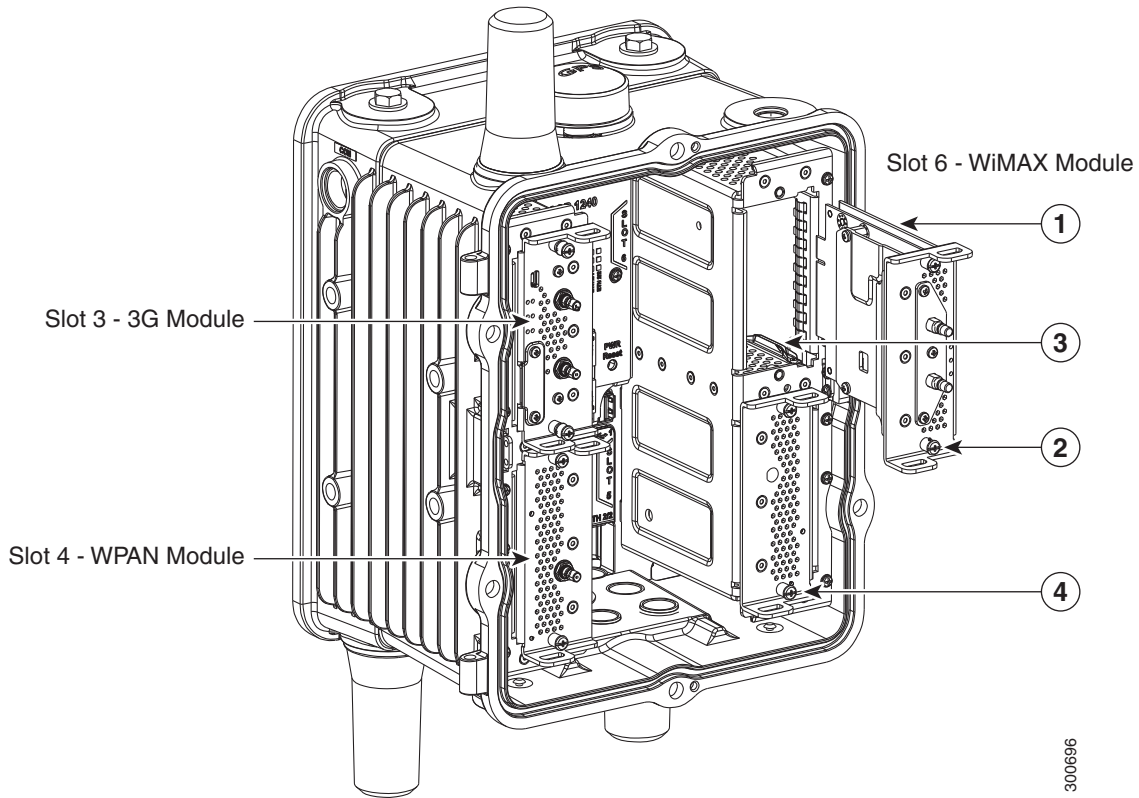

Item	Description	Quantity
1	Module guide edge	Slide module guide edge along the module guide (inside the slot) when inserting module.
2	Captive screws	Two captive screws hold each module (and module slot cover) in place in the module slot.
3	Slot module guide	Slide module guide edge along the module guide (inside the slot) when inserting module.
4	Module slot cover	Module slots WITHOUT modules installed should be covered with a module slot cover.

Installing a Module in an Online Router

The Cisco Connected Grid Device Manager (Device Manager) is used to install a module in an online router. Device Manager is a Windows-based application that field technicians can use to manage the Cisco 1000 Series Connected Grid Routers (CGR 1000) over WiFi or Ethernet.

Note: The Device Manager can only be used on routers using the Cisco CG-OS operating system. It will not work on routers using the Cisco IOS operating system.

For routers using the Cisco IOS operating system, modules must be installed when the router is offline.

Note: For instructions on how to install a module in an online router, see the “Manage Modules” and “Add a Module” sections in the “Using the Device Manager” chapter of the *Cisco Connected Grid Device Manager Installation and User Guide* on Cisco.com.

Note: This is a general installation procedure for installing modules in the chassis of an online router. For hardware installation and software configuration steps that are specific to your module, see the installation and configuration guide for the module, at: www.cisco.com/go/cg-modules.

Removing a Module from an Offline Router

To remove a module from an offline router:

1. Disconnect the router from AC power and disable any installed battery backup units by following the steps in [Powering Off the Router, page 107](#).
2. Open the chassis door by following the steps in [Opening and Closing the Router Chassis, page 75](#).
3. Remove any antenna cables that are connected to module. Ensure that you are using a ??? tool to remove the MCX connector from the ports. This step is specific to the module type.

Note: Refer to the installation and configuration guide for the module, at www.cisco.com/go/cg-modules.

4. Move the 10.5 in cable connected to port 5 away from the BBU cable before removing the MCX connector.
5. Use the screwdriver to loosen the module captive screws (two per module) from the connectors on the router front panel.
6. Use your hands to gently pull the module from the router.
7. Close the router door by following the steps in [Opening and Closing the Router Chassis, page 75](#).
8. Connect the router to AC power and to the network by following the steps in [Installing the Router, page 85](#).
9. Re-enable the BBU using the commands in [Related Commands, page 160](#).

Removing a Module from an Online Router

The Cisco Connected Grid Device Manager (Device Manager) is used to remove a module from an online router. Device Manager is a Windows-based application that field technicians can use to manage the Cisco 1000 Series Connected Grid Routers (CGR 1000) over WiFi or Ethernet.

Note: For instructions on how to remove a module from an online router, see the “Manage Modules” and “Remove a Module” sections in the “Using the Device Manager” chapter of the *Cisco Connected Grid Device Manager Installation and User Guide* on Cisco.com.

Module Documentation

For instructions on how to install, replace, and configure the modules, see these installation and configuration guides on Cisco.com, at: www.cisco.com/go/cg-modules.

Table 23 Connected Grid Modules for CGR 1000 Series Routers Documentation

Connected Grid Module	Related Documentation
Cisco Connected Grid Modules for CGR 1000 Series – Cellular 3G CDMA (Cisco IOS)	Connected Grid 3G CDMA Module for CGR 1000 Series Installation and Configuration Guide (Cisco IOS)
Cisco Connected Grid Modules for CGR 1000 Series – Cellular 3G GSM (Cisco IOS)	Cisco Connected Grid 3G GSM Module for CGR 1000 Series Installation and Configuration Guide (Cisco IOS)
Cisco Connected Grid Modules for CGR 1000 Series – Cellular 3G CDMA/GSM	Cisco Connected Grid Cellular 3G Module for CGR 1000 Series Installation and Configuration Guide
Cisco Connected Grid Modules for CGR 1000 Series – Cellular 4G LTE (Cisco IOS)	Cisco Connected Grid 4G LTE Module Installation and Configuration Guide

Table 23 Connected Grid Modules for CGR 1000 Series Routers Documentation (continued)

Connected Grid Module	Related Documentation
Cisco Connected Grid Modules for CGR 1000 Series - WiMAX	Cisco Connected Grid WiMAX Module for CGR 1000 Series Installation and Configuration Guide
Cisco Connected Grid Modules for CGR 1000 Series -WiFi	Cisco Connected Grid Routers WiFi Software Configuration Guide
Cisco Connected Grid Modules for CGR 1000 Series - WPAN/CG-Mesh	Cisco Connected Grid WPAN Module for CGR1000 Series Installation and CG-Mesh Configuration Guide (Cisco IOS)
Cisco Connected Grid Modules for CGR 1000 Series - WPAN/RFLAN	Cisco Connected Grid Cellular WPAN Module for CGR 1000 Series Installation and RFLAN Configuration Guide



Antennas

This section contains information about supported antennas for the Cisco 1240 Connected Grid Router. Router antennas provide connectivity to the GPS satellite constellation and provide connectivity to a WiFi access unit, as well as to the Cisco Connected Grid modules installed in the router.

Note: For the purposes of this document antennas that mount directly to the chassis are referred to as integrated antennas. External antennas are any antennas that are connected to the router antenna port N-connector (see [Figure 77 on page 122](#)) with an external cable. Ensure that you torque the integrated antennas to 6–7 ft-lbs (72–84 lbs-in).

These topics are discussed:

- [Installing or Replacing Antennas, page 121](#)
- [Antenna Overview, page 122](#)
- [Antenna Port States and Numbering, page 125](#)
- [Safety Information, page 129](#)
- [Antenna Technical Specifications, page 129](#)

Installing or Replacing Antennas

Depending on the configuration you specified, the router could arrive in the shipping container with all required antennas already installed and connected to the corresponding Cisco Connected Grid modules, also installed in the router.

However, you might need to install an antenna when:

- You purchase a module separately from the router. The antenna is included with the module, and must be installed on the router to complete the module installation.
- You purchase an antenna separately to replace a faulty or damaged antenna.

For procedures and safety information required to install or replace antennas, see the Connected Grid antennas documentation, at: www.cisco.com/go/cg-modules.

Lightning Arrestor

Every external antenna that is installed on the router requires a lightning arrestor. [Figure 77 on page 122](#) shows an antenna port, N-connector, and lightning arrestor assembly. You can order lightning arrestors from Cisco using product ID (PID) CGR-LA-NM-NF.

Figure 77 Antenna Port, N-connector, and Lightning Arrestor Assembly

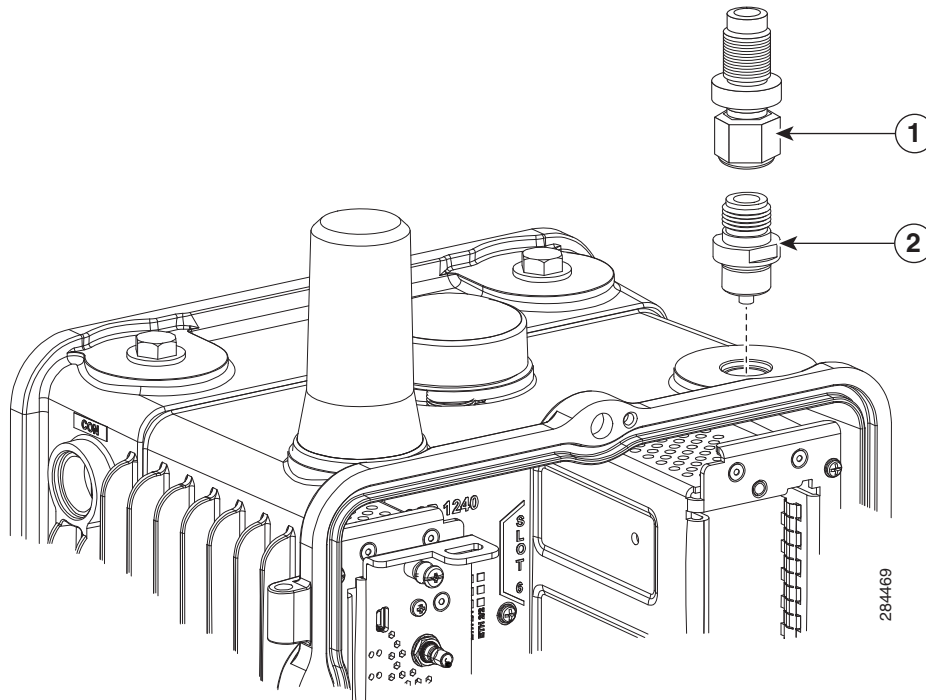

- 1 Lightning arrestor 2 N-connector

External antennas are any antennas that are connected to the router antenna port N-connector.

For information about the lightning arrestor and how to install it, see the Connected Grid antennas and accessories documentation, at: www.cisco.com/go/cg-modules

Cisco Connected Grid Modules

- For instructions on how to install or replace modules in the router, see the Connected Grid module documentation at: www.cisco.com/go/cg-modules

Antenna Overview

This section describes the type of antennas to use with the router.

Default Antennas

The router ships with two pre-installed antennas:

- [GPS Antenna, page 123](#)
- [WiFi Antenna, page 123](#)

Module Antennas

Depending on configuration selected by the customer, the router may ship with additional antennas pre-installed. The router supports up to seven module antennas. See [Connected Grid Module Antennas, page 124](#).

GPS Antenna

The router ships with one outdoor GPS antenna pre-installed and connected internally to the on-board GPS module on the CGR 1240 motherboard. The GPS is used to identify the router location after the router is installed and is in use.

The pre-installed GPS antenna is not a field-replaceable component.

- For detailed technical information about the GPS antenna, see [GPS Antenna Specification, page 130](#).
- For information about the GPS status LED, located inside the router chassis, see [Router LED Locations and States, page 181](#).
- For more information about the GPS module, see [GPS Module, page 41](#).

Figure 78 GPS Antenna—Cisco CGR 1240 Router

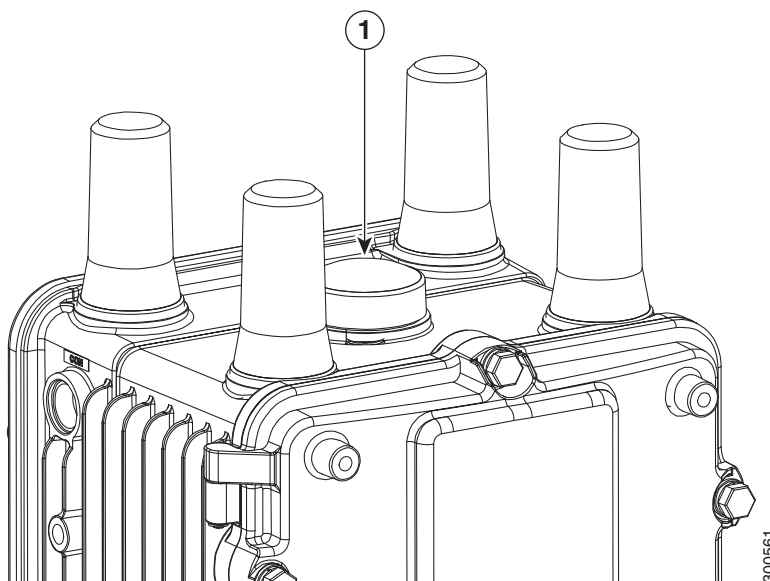

Item	Description
1	GPS antenna

WiFi Antenna

The router ships with a WiFi antenna already installed and connected to the router internal short-range access point. The router WiFi link enables users to connect to the router from anywhere within WiFi range. For example, a technician can check the status of the router from the ground (instead of having to physically open the router on its poletop installation) by remotely connecting to the router over the WiFi link.

For detailed technical information about the WiFi antenna, see [WiFi Antenna Specification, page 130](#).

For more information about WiFi functionality:

- See [Router LED Locations and States, page 181](#) to learn about the WiFi status LED.
- See [WiFi Short-Range Access Point, page 43](#) to learn about the WiFi connection to the router.

Figure 79 WiFi Antenna—Cisco CGR 1240 Router

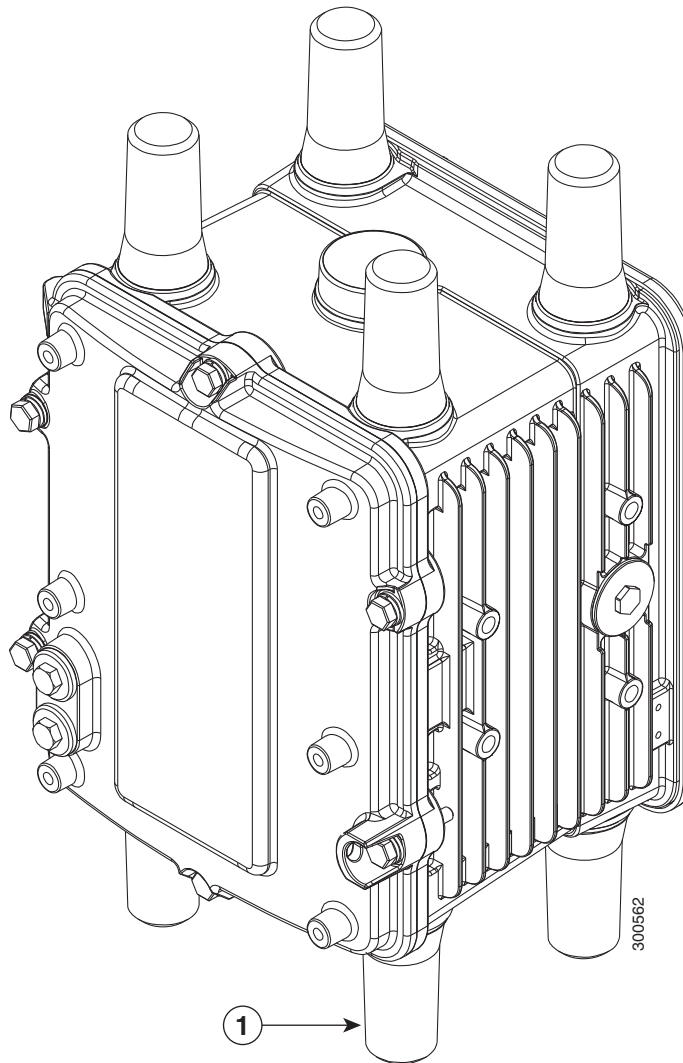

Item	Description
1	WiFi antenna location

Connected Grid Module Antennas

In addition to the two pre-installed antennas (GPS and WiFi), the router supports up to seven additional antennas, which provide connectivity to the modules installed in the router. The additional antennas are mounted on the exterior of the router and connected through chassis antenna ports to the module installed inside the router. For information on the location of the additional antenna ports, see [Antenna Port Numbering, page 127](#).

The router supports up to four modules. Each module requires one antenna or two antennas (one main antenna and one auxiliary antenna). Auxiliary antennas (also known as diversity antennas) improve the quality and reliability of the wireless connection. Because they are placed in different locations on the router, main and auxiliary antennas detect different amounts of desired signal as well as different amounts of interference. The router uses the a digital signal processing called Maximal Ratio Combining (MRC) method to weight, adjust and combine the signals from the two antennas in order to maximize the desired signal level and minimize undesired interference level thereby optimizing the signal to interference plus noise ratio (SINR).

The total number of antennas installed on the router depends on:

- Number of modules installed in the router
- Module types that are installed in the router
- For detailed information about these antennas, see the Connected Grid antennas documentation, at: www.cisco.com/go/cg-modules

Antenna Port States and Numbering

This section describes the antenna ports, and includes the following topics:

- [Antenna Port States, page 125](#)
- [Antenna Port Numbering, page 127](#)

Antenna Port States

- [Antenna Port with Integrated Antenna Installed, page 125](#)
- [Antenna Port in Unused State, page 125](#)
- [Antenna Port in Ready for External Antenna State, page 126](#)
- [Antenna Port in External Antenna Connected State, page 127](#)

Antenna Port with Integrated Antenna Installed

Note: An integrated antenna is an antenna that mounts directly to the chassis. The antenna is mounted in an antenna port. Ensure that you torque the integrated antennas to 6–7 ft-lbs (72–84 lbs-in).

The router ships with two antenna ports containing the following integrated antenna:

- GPS antenna—see [Figure 78 on page 123](#)
- WiFi antenna—see [Figure 79 on page 124](#)

Antenna Port in Unused State

Waterproof port plugs cover unused antenna ports.

Figure 80 Unused Antenna Port with Port Plug Installed

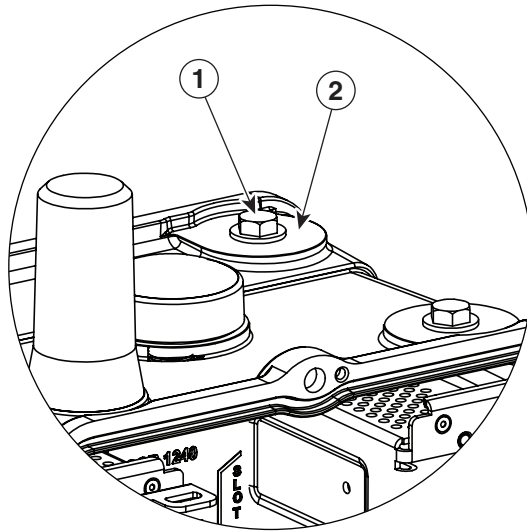

1 Port plug

2 Antenna port

Antenna Port in Ready for External Antenna State

A female N-connector can be installed in any unused antenna port to prepare it for connection to an external antenna. The N-connector protects the router interior from environmental elements including water, heat, cold, and dust. The N-connector must have a watertight dust cap attached to ensure that it is watertight.

Caution: Do not remove N-connectors from antenna ports on the rear side of the unit. This will cause the cable connected to it to drop inside of the device.

Note: Ensure that you torque the female N-connector to 6-7 ft-lbs. Ensure that you torque the integrated antennas to 6-7 ft-lbs (72-84 lbs-in).

Note: When installing an antenna plug, be sure to torque the plug to 6-7 ft-lbs. Ensure that you torque the integrated antennas to 6-7 ft-lbs (72-84 lbs-in).

Note: A dust cap is *not* required when the lightning arrestor, coaxial cable and external antenna are connected to the N-connector.

Figure 81 Antenna in Ready for External Antenna State with N-Connector Installed

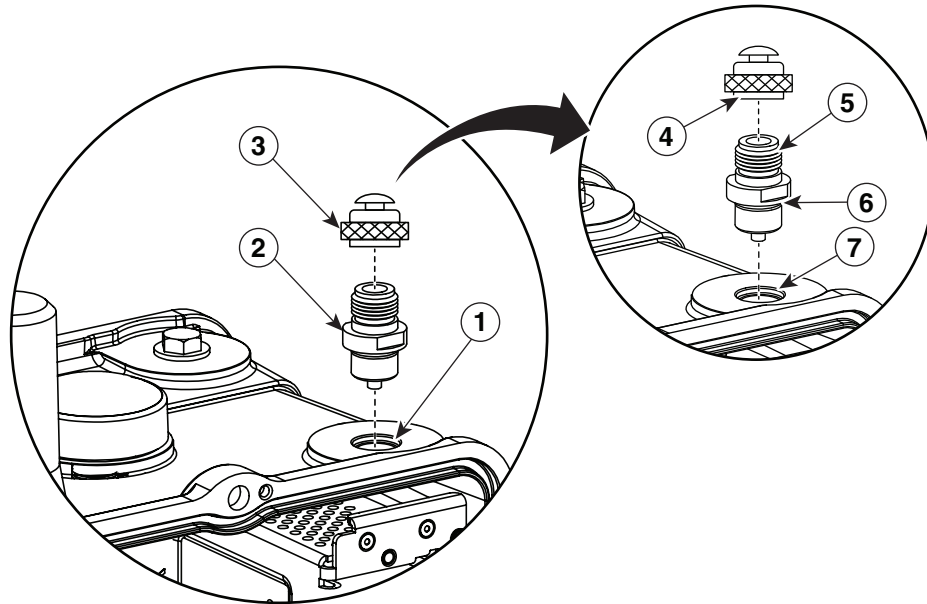

- | | | | |
|---|------------------------|---|------------------------|
| 1 | Antenna port | 5 | 5/8-24 UNEF-2A threads |
| 2 | N-connector | 6 | 5/8-24 UNEF-2A threads |
| 3 | Water-tight dust cap | 7 | 5/8-24 UNEF-2B threads |
| 4 | 5/8-24 UNEF-2B threads | | |

392064

Antenna Port in External Antenna Connected State

An antenna port with an external antenna connected has the following items installed:

- N-connector
- Lightning arrester
- External antenna cable
- External antenna

For information about the lightning arrester, see the [Lightning Arrester for the Cisco 1240 Connected Grid Router](#) guide on Cisco.com

For detailed instructions for installing antennas and lightning arrestors, see the [Connected Grid Antennas Installation Guide](#) on Cisco.com.

Antenna Port Numbering

This section illustrates the antenna port locations on the router. The antenna port numbers should be referenced by installers, support technicians, and other end users when installing, replacing, or troubleshooting the antennas.

Antenna Installation Location

Caution: Supported antennas can be installed in any of the router antenna ports, however Cisco recommends that antennas be installed in the locations recommended in the antenna installation guide. Installing antennas in the recommend locations optimizes ease of installation, antenna performance. and antenna cable management.

The recommended location for each antenna depends on several factors, including:

- The type and number of modules installed in the router
- The type and number of antennas required to support the installed modules

The procedures in the antenna installation guide refer to the port numbers illustrated in this section.

Figure 82 Top of Router—Antenna Port Numbering

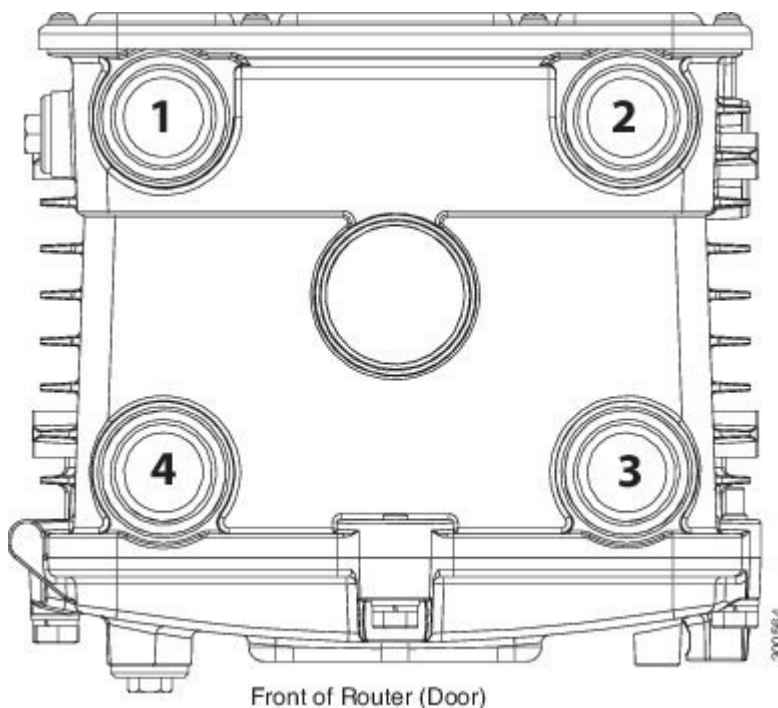
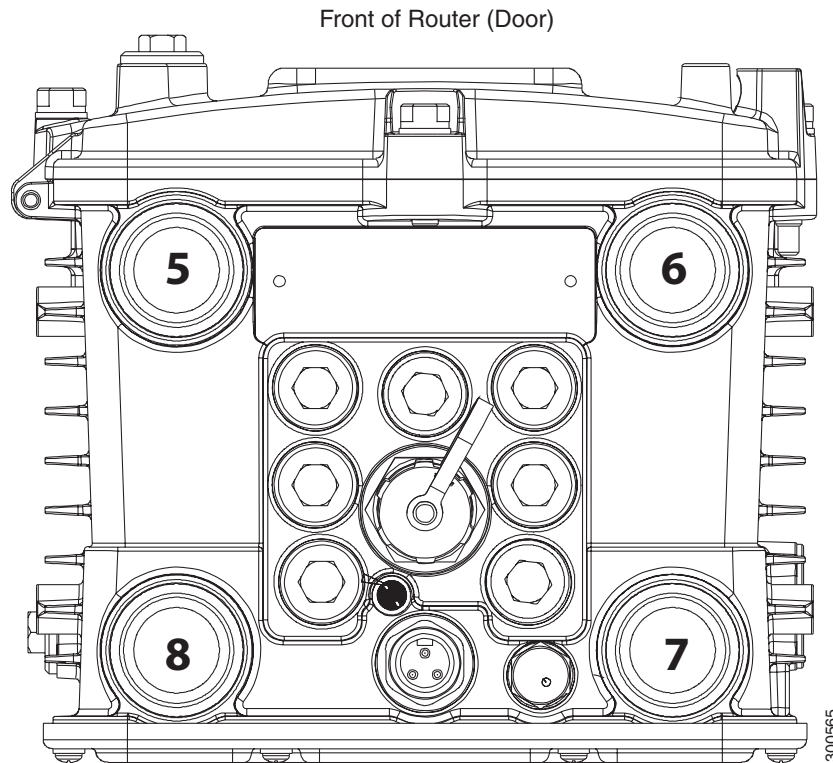

Figure 83 Bottom of Router—Antenna Port Numbering



Antenna Port	Antenna Type
1	4GLTE/WIMAX auxiliary antenna
2	4GLTE/WIMAX main antenna
3	3G/4G main antenna
4	3G/4G auxiliary antenna
5	900 MHz antenna
6	Integrated WiFi antenna (router ships with this antenna installed)
7	-
8	-

Safety Information

Read the information in the antenna installation guide before installing or replacing antennas.

Antenna Technical Specifications

This section lists the technical information for the GPS and WiFi antennas:

- [GPS Antenna Specification, page 130](#)
- [WiFi Antenna Specification, page 130](#)

For more information about Cisco Connected Grid antennas see the [Connected Grid Antennas Installation Guide](#).

GPS Antenna Specification

Table 24 GPS Antenna Specification

Specification	GPS Antenna
Type	Active GPS, chassis mounted
Frequency	1575.42 MHz
Height	22.1 mm
Base diameter	50 mm
Maximum gain (dBi)	5
Polarization	RHCP
Coaxial cable length	10 in. (25.4 cm)
Coaxial cable type	50 Ohms, double-shielded, LMR-100A
Connector	MCX
Environment	Outdoor
Temperature range, operational	-40 to 185° F (-40 to 85° C)
Temperature range, storage	-40 to 185° F (-40 to 85° C)

WiFi Antenna Specification

Table 25 WiFi Antenna Specification

Specification	WiFi Antenna
Type	Monopole
Environment	Outdoor
Height	3.2 in. (8.13 cm)
Width (maximum, at base)	1.75 in. (4.45 cm)
Operating frequency range	806-960 MHz 1710-2170 MHz 2300-2700MHz
Characteristic impedance	50 ohm
VSWR	Nominal (Maximum) 806-960 MHz (2.5:1) 1710-2170 MHz (2.3:1) 2300-2700 MHz (2.2:1)
Peak gain	Nominal (Maximum) 806-960 MHz (2.5 dBi +/- 1.0 dB) 1710-2170 MHz (1.0 dBi +/- 1.0 dB) 2300-2500 MHz (1.0 dBi +/- 1.0 dB) 2500-2700 MHz (2.5 dBi +/- 1.2 dB)

Table 25 WiFi Antenna Specification (continued)

Specification	WiFi Antenna
Polarization	Linear Vertical
Coaxial cable length	8 inches (20.3 cm), LMR-100A
Connector	MCX
Temperature range, operational	-40 to 185° F (-40 to 85° C)
Temperature range, storage	-40 to 185° F (-40 to 85° C)
Maximum input power	10 W (avg.)
Compliance	RoHS





Using the SD Flash Memory Module

This section describes the Secure Digital (SD) flash memory module (or SD card) used with the Cisco 1240 Connected Grid Router (CGR 1240 or router), and includes instructions for installing and removing the SD card.

These topics are discussed:

- [SD Flash Memory Module, page 133](#)
- [Accessing the SD Card, page 134](#)
- [SD Card Status, page 135](#)
- [Securing the SD Card with a Password, page 136](#)
- [Related Commands, page 137](#)

SD Flash Memory Module

The router features an SD card connector, which supports a single Cisco SD flash memory module (SD card). The SD card stores router data and software, including:

- Router operating software
- Running configurations
- Network management software configuration
- Network registration data
- Router firmware

The topics in this section include:

- [SD Card File System, page 133](#)
- [Supported SD Cards, page 133](#)

SD Card File System

The SD card uses a Linux-based EXT2/3 file system. The router configuration is stored in a binary file in an invisible partition on the card.

Supported SD Cards

[Table 26 on page 133](#) lists the SD cards that can be used with the router.

Table 26 Supported SD Flash Modules

Size
2-GB flash memory module

Accessing the SD Card

The SD card and SD card LED are accessed from the router exterior, through the router SD card port, shown in [Figure 84 on page 134](#).

Caution: Do not remove the SD card from the router; removing the SD card causes the router to stop operating.

The topics in this section include:

- [Accessing the SD Card on a Router with a Mounting Bracket, page 134](#)

Accessing the SD Card on a Router with a Mounting Bracket

When the Cisco mounting bracket is attached to the router, the bracket blocks access to the SD card port slot on the router exterior. To access the SD card slot without removing the router from the bracket or any mounting installation that uses the bracket, refer to the instructions in [Mounting the Router, page 45](#).

Figure 84 SD Card Port Location on Router Exterior

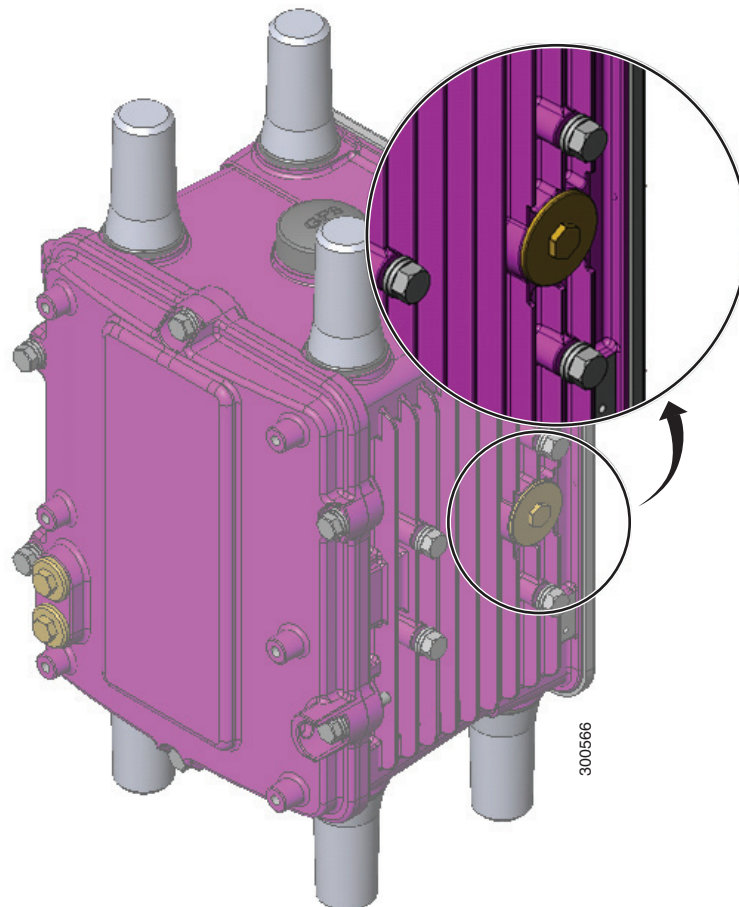
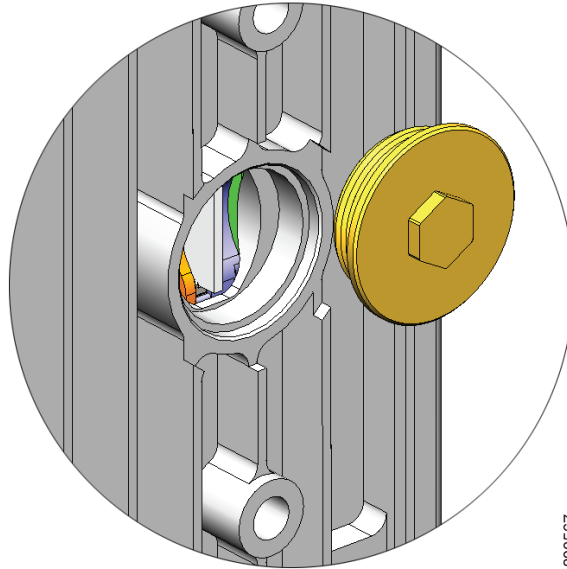

Figure 85 SD Card Slot with SD Card Inserted



SD Card Status

- [SD Card LED, page 135](#)

SD Card LED

The SD card LED is located directly next to the SD card slot, and is visible when the SD card slot seal is removed. This section describes the LED states and descriptions.

Figure 86 SD Card LED Location

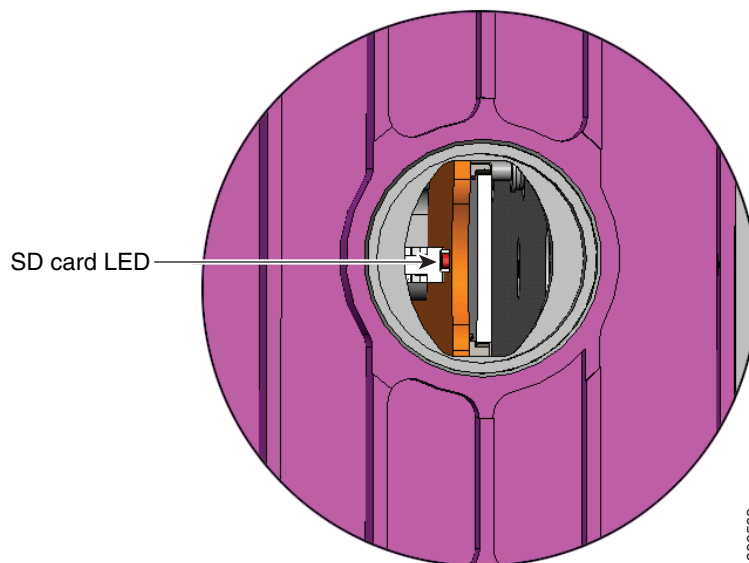

Table 27 SD Flash Memory Module LED States

Description	Color and State	Description
SD card status	Green solid	SD flash card is installed and operating normally. Note: If the SD Card is removed, the SD flash memory module LED remains green solid until the router reboots.
	Green blinking	A data transfer between the router and the SD card is in progress.
	Amber solid	<ul style="list-style-type: none">■ An error occurred when the router accessed the SD flash card.■ The router could not find a system software image.
	Amber blinking	An unsupported SD card is installed in the slot.

Securing the SD Card with a Password

Note: The CLI cited in this section work for both the CG-OS and Cisco IOS operating systems.

The SD card contents can be secured with a password. Once a password is set, the password must be supplied before data can be accessed on the SD card.

The SD card password must be set during system initialization, and you will be notified that the system must be rebooted for the new password to take effect. The password can be set at the CLI or through the CG-NMS.

To set and remove SD card passwords and display their status, see:

- [Setting and Removing an SD Card Password, page 136](#)
- [Displaying the SD Card Password Status, page 136](#)

Setting and Removing an SD Card Password

To set a password for the SD-card, use the **sd-card password password** command in global configuration mode to set the password. Use the **no sd-card password** command in global configuration mode to remove the password.

Displaying the SD Card Password Status

The SD Card password status can be:

- Unlocked
- Locked
- Password set/reset, reboot pending

To determine the status of the SD card password, you can use the **show sd-card password status** command in user EXEC mode.

```
cgr1240# show sd-card password status
```

```
SD-card lock status: [Locked, reboot required to apply.]
```

The command output indicates that the SD card is password secured but the router must be rebooted for the password to apply.

The status of an SD card fully secured by a password the status is [Locked], and an SD card unsecured by a password has [Unlocked] status.

Related Commands

Note: The commands in this section work on routers running the Cisco CG-OS or Cisco IOS operating systems.

- [copy running-config startup-config, page 137](#)
- [sd-card password, page 137](#)
- [no sd-card password, page 137](#)
- [show sd-card password status, page 137](#)

copy running-config startup-config

To save the router current software configuration to the SD card, use the **copy running-config startup-config** command in user EXEC mode:

```
cgr1240# copy running-config startup-config
[#####] 100%
Copy complete, now saving to disk (please wait)...
```

sd-card password

To set a password for the SD card, use the **sd-card password password** command in global configuration mode.

```
cgr1240(config)# sd-card password password
```

no sd-card password

To remove the SD card password, use the **no sd-card password** command in global configuration mode.

```
cgr1240(config)# no sd-card password
```

show sd-card password status

To determine the status of the SD card password, use the **show sd-card password status** command in user EXEC mode.

```
cgr1240# show sd-card password status
```

Field Replacement of the SD Card

The SD card can contain either the IOS operating system or the CGIOS operating system. There are different procedures for replacing each version.

SD Card Replacement with the IOS Operating System

1. If your router is using a battery backup system, you will need to disable it before powering down the device.

```
CGR1000# battery charge-discharge disable
```

2. Unplug the power cord from the router.
3. Once the router has powered off, remove the old SD card from the SD card slot.

-
4. Insert the new SD card into the SD card slot.
 5. Connect the power cord to the router.
 6. If there is no change in the binary version of the OS, the router will autoboot correctly.
 - a. Once the router completely boots up and is running, skip to step 13.
 7. If there is a difference in the binary version of the OS, the router will stop at the rommon-1 prompt
 8. From the rommon-1 prompt, confirm the availability of hypervisor and the IOS image using the following commands:

```
rommon-1> dir
flash: cgr1000-universalk9-mz.SPA.156-3.M2
bootstrap: bootstrap:cgr1000-hv.srp.SPA.2.0.12
```

9. Set the hypervisor boot string using the following command:

```
rommon-1> set BOOT_HV=bootstrap:cgr1000-hv.srp.SPA.2.0.12
```

10. Set the IOS boot string using the following command:

```
rommon-1> set BOOT=flash:cgr1000-universalk9-mz.SPA.156-3.M2
```

11. Reload the router:

```
rommon-1> reboot
```

12. Once the router has reloaded and comes back up, it is ready to use.
13. If your router is using a battery backup system, you will need to re-enable it.

```
CGR1000# battery charge-discharge enable
```

SD Card Replacement with the CGOS Operating System

The procedure for replacing the SD card running CGOS is more complex because the CGOS stores all the configuration and encrypted private keys and certificates in different SD card partitions. IOS stores all of these in the NVRAM of the CGR1000 router mainboard.

Prior to replacing the SD card, make sure that the running configuration on the SD card is backed up to a tftp server. For example:

```
CGR1000# copy running-config tftp://192.168.0.1/original-config
```

After backing up the running configuration, replace the SD card using the following steps:

1. If your router is using a battery backup system, you will need to disable it before powering down the device.

```
CGR1000# backup-battery inhibit discharge
```

2. Unplug the power cord from the router.
3. Once the router has powered off, remove the old SD card from the SD card slot.
4. Insert the new SD card into the SD card slot.
5. Connect the power cord to the router.
6. If there is no change in the binary version of the CG-OS kickstart and system images, the router will autoboot correctly. Once the router completely boots up, go to step 11.

7. If there is a difference in the binary version of the CG-OS kickstart and system images, the router will stop at the **loader>** prompt.

8. From the prompt, confirm the availability of kickstart and the system images using the following commands:

```
loader> dir
bootflash:
  cgr1000-uk9-kickstart.5.2.1.CG4.5.SPA.bin
  cgr1000-uk9.5.2.1.CG4.5.SPA.bin
```

9. Boot the kickstart image:

```
loader> boot bootflash:cgr1000-uk9-kickstart.5.2.1.CG4.5.SPA.bin
```

10. Once the kickstart image has finished booting, load the system image:

```
CGR1000 (boot) # load bootflash:cgr1000-uk9.5.2.1.CG4.5.SPA.bin
```

11. When the system image finishes loading, the **System Admin Account Setup** dialog will be shown.

12. Enter a password for the **admin** account when the prompt **Enter the password for admin:** is shown.

13. Skip the **Basic configuration** dialog by entering **no**.

14. Log into the router using **admin** and password that you entered in the step 12.

15. Configure the IP address for an Ethernet interface (e.g. Ethernet 2/1) and use **tftp** to copy the configuration file you obtained from the original SD card to the bootflash. For example:

```
cgr1000# copy tftp://192.168.0.1/original-config bootflash:original-config
```

16. Restore the original configuration.

```
cgr1000# copy bootflash:original-config running-config
```

17. Set the CG-GOS boot kickstart and system variables:

```
cgr1000 (config) # boot kickstart bootflash:/cgr1000-uk9-kickstart.5.2.1.CG4.5.SPA.bin
cgr1000 (config) # boot system bootflash:/cgr1000-uk9.5.2.1.CG4.5.SPA.bin
```

18. Save the running-config to the startup-config, and reload the router:

```
cgr1000# copy running-config startup-config
cgr1000# reload
```

19. Once the router has reloaded and comes back up, it is ready to use.

20. If the router has any certificate trustpoint in the original configuration, its certificate and CA certificate must be re-acquired for the trust-point via SCEP or manual certificate import.

21. If your router is using a battery backup system, you will need to re-enable it:

```
CGR1000# backup-battery un-inhibit discharge
```





Installing Battery Backup Units (BBUs)

The Cisco 1240 Connected Grid Router (CGR 1240 or router) supports up to three battery backup units (BBUs), which provide power to the router if the router AC power supply fails or is not available. This section describes the BBU features and installation procedures.

These topics are discussed:

- [Battery Backup Units, page 141](#)
- [BBU Lifecycle Handling and Storage Guidelines, page 144](#)
- [Preparing to Install the BBU, page 146](#)
- [Installing a BBU in the Router, page 150](#)
- [Disabling and Enabling the BBU in the Router, page 155](#)
- [Battery Backup Unit LED, page 159](#)
- [Related Commands, page 160](#)
- [BBU Technical Specifications, page 170](#)

Battery Backup Units

This section contains information about:

- [Battery Backup Operations, page 141](#)
- [BBU Status, page 142](#)
- [BBU Firmware Upgrade, page 143](#)
- [BBU Capacity, page 144](#)

Battery Backup Operations

The battery backup unit (BBU) provides the router with an emergency power source if the AC power source is unavailable.

The router supports up to three BBU units installed at one time. The units are mounted on the router door interior ([Figure 87 on page 142](#)).

The total amount of time that the installed BBUs can supply power to the router depends on the configuration of the FAR and how many BBUs are installed in the router.

The BBU can be installed in the router while the router is powered on and operating normally.

The BBU internal components include battery cells, a primary protection circuit, a fuel gauge, and a charger. For detailed, illustrated descriptions of the BBU, see [BBU Components, page 147](#).

Figure 87 Battery Backup Units Mounted on Router Door

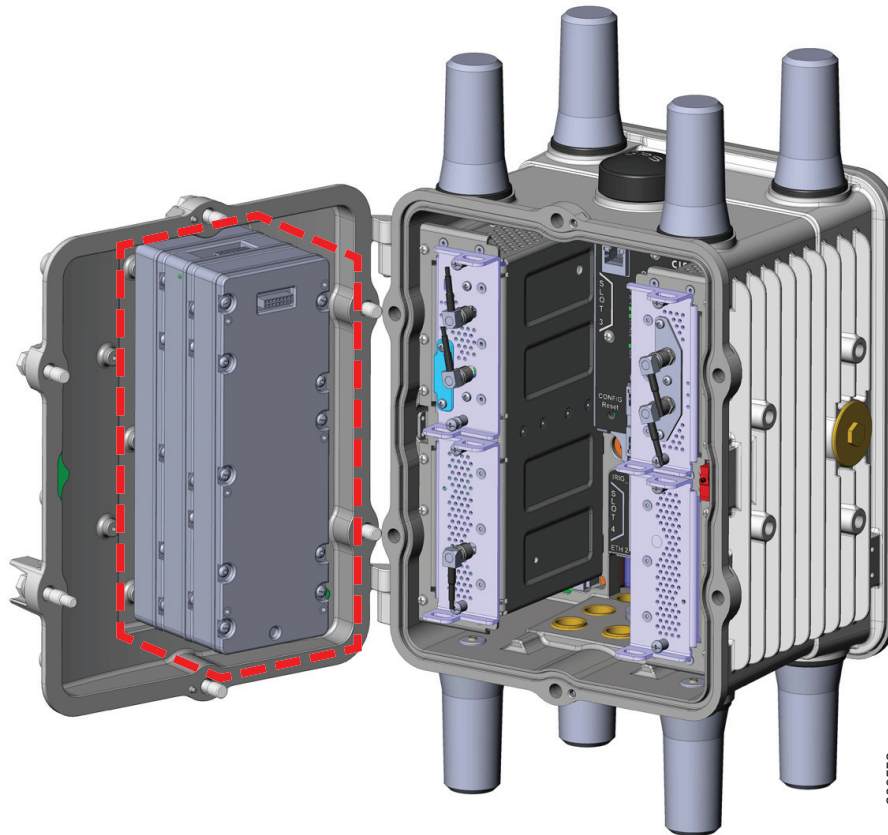

Item	Cisco Product ID (PID)	Description
1	CGR-BATT-4AH	Battery backup units. The router supports up to three BBUs. Figure 87 shows the router with three BBUs, highlighted in red.

BBU Status

The BBU is automatically enabled and begins supplying power to the router when the router detects that power is not being received from the AC power supply. The BBU continues to supply power to the router until at least one of the following conditions is met:

- All BBUs are completely discharged
- AC power to the router is enabled
- The BBU is disabled with software commands (see [Related Commands, page 160](#))

Note: For information on technical details about the router power path selection and the conditions that trigger the BBU to begin operating, see [BBU Technical Specifications, page 170](#).

Battery Backup Mode

This section describes the impact on the router configuration and operating capabilities when the router switches from AC power to BBU power.

These topics are discussed:

- [Router Configuration, page 143](#)
- [Ethernet Switch and Connected Grid Module Operation, page 143](#)
- [Router Interface Operation, page 143](#)

Router Configuration

The router software configuration is not impacted when the router switches from AC power to BBU power.

Ethernet Switch and Connected Grid Module Operation

By default, the Ethernet switch module (referred to as module 2 in the system software) and any modules installed in slots 3, 4, 5, and 6 continue to operate normally when the router switches from AC power to BBU power.

On routers using the Cisco CG-OS operating system, you can use the **poweroff module *number* backup-battery** command to configure the modules (including the Ethernet switch) to shut down when the router switches to BBU power. See [poweroff module *number* backup-battery, page 163](#).

You can configure the router to automatically power off specific modules when the router switches to BBU power.

Note: You can only use the **poweroff module *number* backup-battery** command to configure modules to shut down when the router switches to BBU power, on routers using the Cisco CG-OS operating system. This CLI action cannot be performed on routers using the Cisco IOS operating system.

Router Interface Operation

To conserve power, the router will power off some interfaces when AC power is not available and the router is being powered by the BBU. The following interfaces and router components switch to power-off mode when the BBU is supplying power to the router:

- Both SFP interfaces
- Both external USB ports
- Both serial (S232/485) ports
- IRIG-B port

When these interfaces are in power-off mode, you cannot configure them with the system software; however, you can display information about each interface using the following **show** commands:

- **show running config**
- **show hardware**
- **show interface**

BBU Firmware Upgrade

Note: You can only use the **backup-battery firmware upgrade** command, to upgrade the BBU firmware and to show information about the BBU firmware upgrade, on routers using the Cisco CG-OS operating system. This command cannot be used on routers using the Cisco IOS operating system.

To upgrade the BBU firmware and to show information about the BBU firmware upgrade, issue the following command:

```
CGR1240# backup-battery firmware upgrade
```

The firmware upgrade is executed in background and a syslog message is displayed when the BBU firmware upgrade has completed. During the firmware upgrade, you can issue the **show environment power** command to view the state of the BBU firmware upgrade.

BBU Capacity

The router supports up to three BBUs at one time. You should install as many BBUs as needed, up to three, to meet your emergency power requirements.

If all installed batteries fully discharge while providing backup power to the router, the router will send a dying gasp message and then shut down.

BBU Lifecycle Handling and Storage Guidelines

This section contains information about the BBU status and condition during the BBU lifecycle and how to approach and manage it. These topics are discussed:

- [BBU Storage Related Definitions, page 144](#)
- [BBU Shipping and Receiving Guidelines, page 144](#)
- [BBU Storage and Handling Guidelines, page 145](#)
- [Recharging a BBU, page 145](#)
- [Replacing a BBU, page 145](#)
- [BBU Disposal Guidelines, page 146](#)

BBU Storage Related Definitions

- [Shelf Life, page 144](#)
- [State of Charge, page 144](#)

Shelf Life

Shelf life is the length of time before a BBU needs to be recharged in order to avoid BBU over-discharge.

State of Charge

State of charge (SOC) is the amount of charge on a battery and it is expressed as a percentage value. For example, an SOC of 100% represents a battery that is fully charged, and an SOC of 0% represents a battery that is fully discharged or has no charge.

BBU Shipping and Receiving Guidelines

The BBU shipping and receiving guidelines define the BBU SOC status and how it can be managed at this stage of the BBU life cycle:

- Cisco ships BBUs with a minimum of 60% SOC from the Cisco contract manufacturer (CM).
- Each BBU should have a minimum SOC of 50% upon receipt from the Cisco CM.
 - A minimum SOC of 50% allows for approximately 10 weeks between shipment from Cisco's CM and a customer checking the SOC.

-
- SOC decreases approximately 1% per week.
 - BBU SOC status can be checked using the command line interface (CLI) or CG-NMS.
 - BBUs with less than 50% SOC should be recharged by the system integrator or customer to >50% SOC.

BBU Storage and Handling Guidelines

The BBU storage and handling guidelines define the BBU shelf life status and how it can be managed at this stage of the BBU lifecycle:

- The shelf life of a BBU installed in a router with discharge disabled and BBU disabled, or for a spare BBU, is a minimum of 365 days.
- Prior to connection to an AC source, the BBU shelf life is a minimum of 21 days.
- When long term storage at a customer site is anticipated, Cisco requires that the BBUs be recharged prior to expiration of shelf life.
- When AC power is disconnected and the Cisco Connected Grid router is removed from service:
 - The CGR switches to DC power supplied by the BBU(s) and remains powered for approximately 8 hours.
 - After 8 hours the BBU(s) reaches low voltage disconnect, and the remaining shelf life is a minimum of 21 days.
 - The BBU should be placed in "BBU disable mode" when the CGR is removed from service in order to extend BBU shelf life up to 365 + 21 days
 - The remaining shelf life depends on the elapsed time between removal of AC power and the BBU placed in "BBU disable mode" .
 - Disabling a BBU at 0% SOC means a minimum remaining shelf life of 21 days, and disabling a BBU 100% SOC means a maximum remaining shelf life of 386 days.

Recharging a BBU

To recharge a BBU:

1. Enable the BBU.
2. Connect the CGR to an AC power source.
3. Allow at least 8 hours of charge time per BBU, i.e. for CGRs with 3 BBUs each, allow 24 hours charge time per CGR.
4. When the charge time is finished, disable the BBU.

Replacing a BBU

Note: When you replace a BBU in the CGR 1240, we highly recommend:

- Replacing all the BBUs.
- Verifying all the replacement BBUs are the same version.

When a CGR 1240 operates with different BBU versions, it may result in misbehavior in the BBU functionality. This condition is seen in CGR 1240s installed with either Cisco IOS or Cisco CG-OS software.

To replace a BBU:

1. Remove AC power from the CGR.
2. Disconnect the BBU Harness from the BBU.
3. Replace all BBUs of the CGR at the same time.

Note: Do not mix used BBUs with new BBUs.

BBU Disposal Guidelines

Instructions for disposal of BBUs

- For CGRs under warranty, follow the standard Cisco RMA procedures.
- If Cisco identifies a BBU or set of BBUs as a non-functional item that can be discarded without being returned for failure analysis, BBUs removed for replacement must be disposed of in accordance with local guidelines.
- US and Canadian customers should utilize www.call2recycle.org to properly recycle the lithium ion BBUs.
- For local recycling outside of the US and Canada, customers should contact the following Cisco email for guidance specific to customer's country/region: environment@cisco.com
- For further local take-back and recycling information, customers can refer to: www.cisco-returns.com

Preparing to Install the BBU

Tools You Supply

You must provide a #1 Phillips screwdriver to install the BBU.

Safety Information for Installation

Safety Warnings

Read the safety warnings in [Installation Safety and Site Preparation, page 3](#).

Warning: There is the danger of explosion if the battery is replaced incorrectly. Replace the battery only with the same or equivalent type recommended by the manufacturer. Dispose of used batteries according to the manufacturer's instructions. Statement 1015

Warning: Only trained and qualified personnel should be allowed to install, replace, or service this equipment. Statement 1030

Note: When you replace a BBU in the CGR 1240, we highly recommend:

- Replacing all the BBUs.
- Verifying all the replacement BBUs are the same version.

When a CGR 1240 operates with different BBU versions, it may result in misbehavior in the BBU functionality. This condition is seen in CGR 1240s installed with either Cisco IOS or Cisco CG-OS software.

Preventing Electrostatic Discharge Damage

The BBUs are sensitive to electrostatic discharge (ESD) damage which can occur when electronic cards or components are handled improperly, and can result in complete or intermittent failures.

To prevent ESD damage, follow these guidelines:

- Always use an ESD wrist or ankle strap and ensure that it makes good skin contact.
- Connect the equipment end of the strap to an unfinished chassis surface.
- Place the BBU on an antistatic surface or in a static shielding bag. If the BBU will be returned to the factory, immediately place it in a static shielding bag.
- Avoid contact between the battery and clothing. The wrist strap protects the battery from ESD voltages on the body only; ESD voltages on clothing can still cause damage.
- Do not remove the wrist strap until the installation is complete.

BBU Components

This section illustrates and describes the BBU components you should be familiar with when installing the BBU.

Note: For technical specifications of the components described in this section, see [BBU Technical Specifications, page 170](#).

- [Battery-to-Battery Connectors, page 148](#)
- [Battery-to-Router Connector, page 149](#)
- [Locating Pin and Notch, page 150](#)

Battery-to-Battery Connectors

Figure 88 Front of Battery Backup Unit

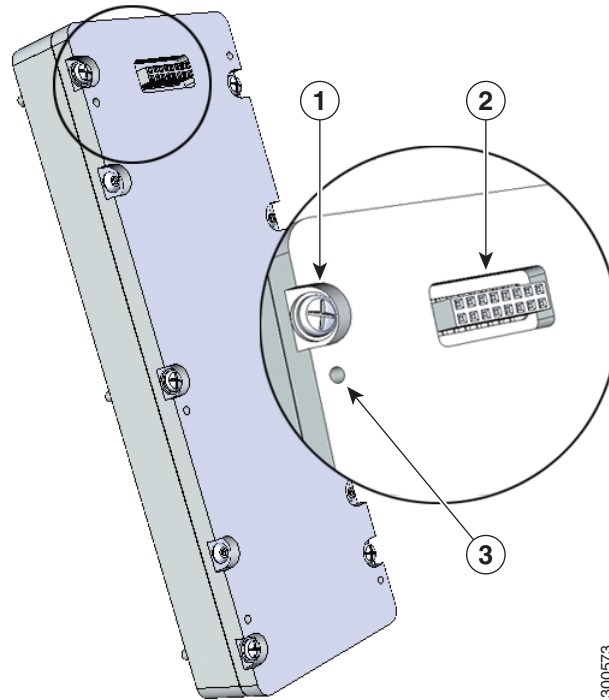

300573

Item Description

- 1 Captive screws (6) for installing the BBU directly to the router door or to another BBU already installed on the router door.
- 2 Battery-to-battery connector, female. The BBU features two battery-to-battery connectors: one male and one female, which are used to connect batteries together when two or more batteries are installed in one router.
- 3 Threaded insert used to attach an additional BBU (6)

Figure 89 Rear of Battery Backup Unit

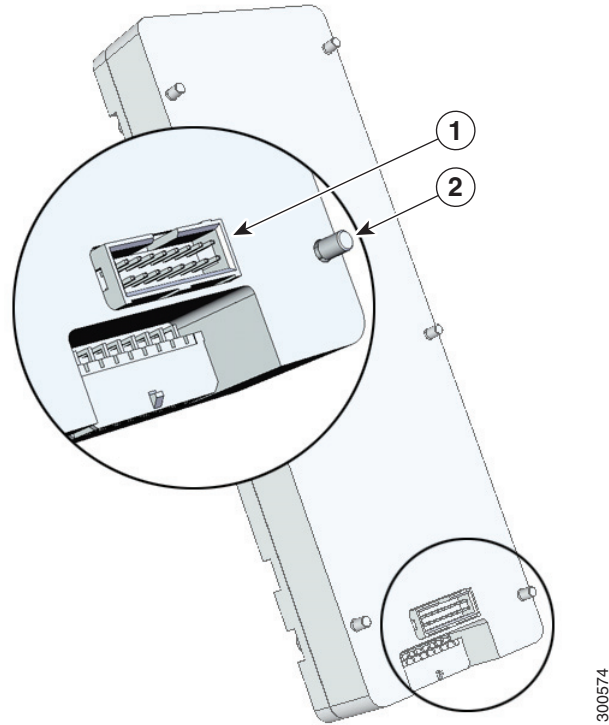

Item	Description
1	Battery-to-battery connector, male. The BBU features two battery-to-battery connectors: one male and one female, which are used to connect batteries together when two or more batteries are installed in one router.
2	Captive screws (6)

Battery-to-Router Connector

The first BBU installed features a single battery-to-router connector at the base, which connects to the BBU cable inside the router (shown in [Figure 92 on page 152](#)).

Figure 90 Battery-to-Router Connector

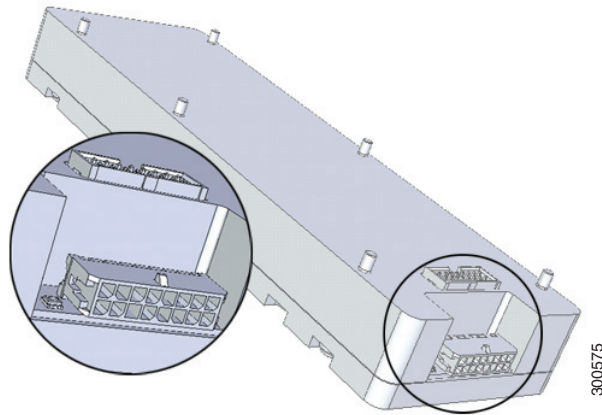

Locating Pin and Notch

When you connect a second or third battery to a battery already installed in the router, use the locating pin and notch to ensure correct battery position and align the battery connectors.

Figure 91 on page 150 illustrates the pin and notch location on the BBU.

Figure 91 Locating Pin and Notch

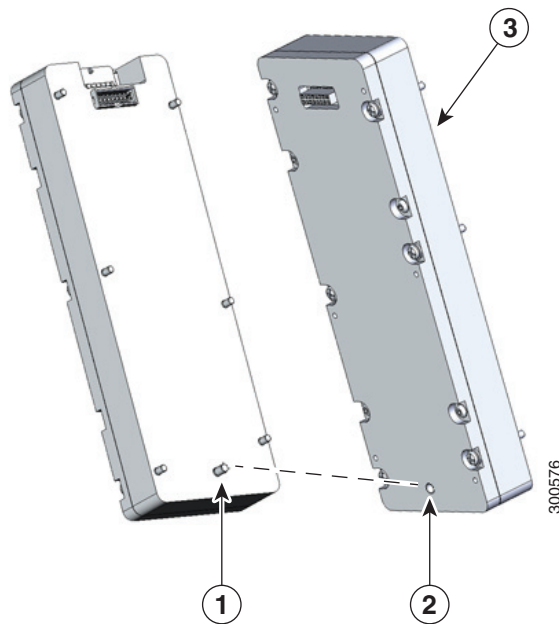

Item	Description	Item	Description
1	Locating notch (back of BBU)	2	Locating pin (front of BBU)
3	Side that attaches to router door		

Installing a BBU in the Router

This section describes how to install a BBU in the router. A new BBU will be about 50% charged when you receive it.

Caution: When you install a BBU in the router, if there is no AC power being supplied to the router, the BBU will immediately begin to power the router when it is connected to the BBU harness cable.

To prevent the BBU charging the router prior to installation in the field, the BBU is disabled during shipment. To ensure the BBU can be charged and power the router when required, enable the BBU right after installation.

Note: When you replace a BBU in the CGR 1240, we highly recommend:

- Replacing all the BBUs.
- Verifying all the replacement BBUs are the same version.

When a CGR 1240 operates with different BBU versions, it may result in misbehavior in the BBU functionality. This condition is seen in CGR 1240s installed with either Cisco IOS or Cisco CG-OS software.

These topics are discussed:

- [Online Insertion and Removal, page 151](#)
- [Installation Illustrations, page 151](#)
- [Installation Procedures, page 151](#)
- [Installing BBU 0, page 153](#)
- [Installing BBU 1 or BBU 2, page 154](#)

Online Insertion and Removal

BBU Online Insertion and Removal (OIR) is not supported by the Cisco CG-OS or Cisco IOS operating systems.

For routers using the Cisco CG-OS operating system, the workaround is to execute the **battery disable** command at the CLI and then perform the insertion or removal. There is no workaround for Cisco IOS.

Installation Illustrations

The procedures in this section refer to the following illustrations:

- BBU components illustrated in [BBU Components, page 147](#)
- Router installation features shown in [Figure 92 on page 152](#)
- BBU installation assembly shown in [Figure 93 on page 153](#)

Installation Procedures

This section includes steps for the following procedures:

- [Installing BBU 0, page 153](#) (Installing a single BBU)
- [Installing BBU 1 or BBU 2, page 154](#) (Installing additional BBUs)

Figure 92 Router Features for BBU Installation

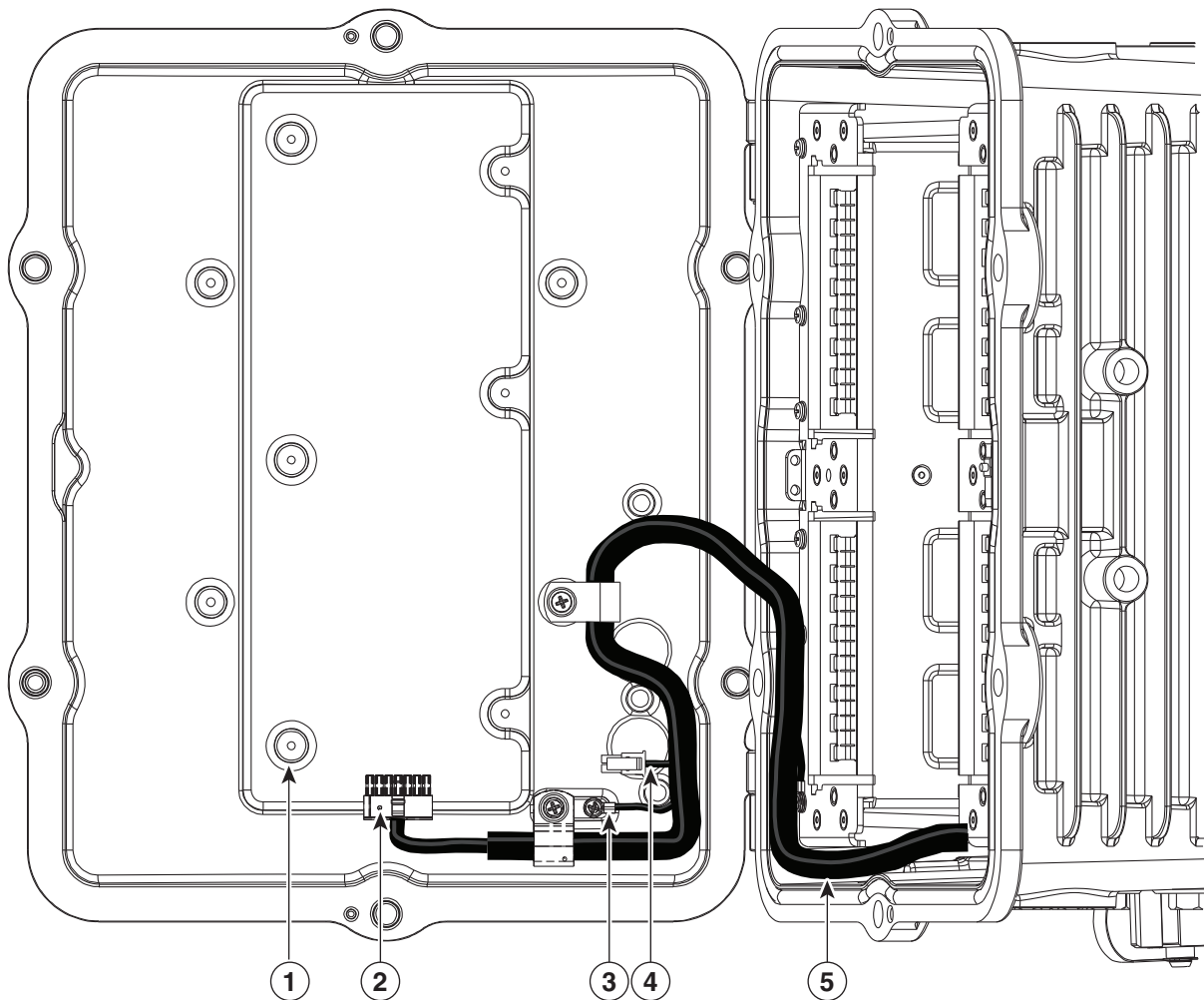

300577

Item	Description
1	Mounting bosses, for installing first BBU to router (6).
2	BBU cable connector. The BBU is connected to the router cable harness with this connector.
3	Ground lug (door to chassis).
4	Non-Cisco module power connector (12 V). If you install a non-Cisco module on the router exterior, you can optionally use this connector to provide power to the module. See Installing External Non-Cisco Modules , page 173.
5	BBU cable harness. The cable harness connects the BBU(s) to the router and is the physical connection over which BBU power is supplied to the router when AC power is not available. The router is shipped with this cable even if the router is not shipped with a BBU installed.

Figure 93 BBU Installation Assembly

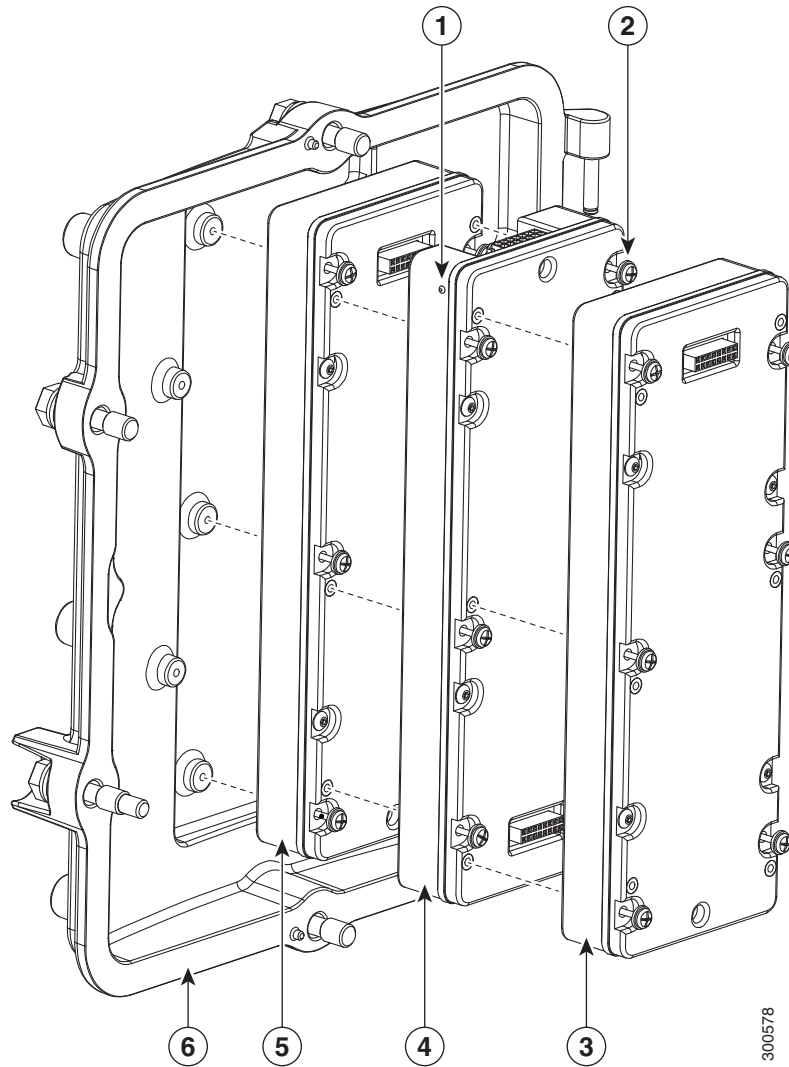

Item	Description
1	BBU LED.
2	Captive screws (6 per BBU). Use 7-9 in-lbs torque when tightening.
3	BBU 2
4	BBU 1
5	BBU 0
6	Router door

Installing BBU 0

Note: When you replace a BBU in the CGR 1240, we highly recommend:

- Replacing all the BBUs.
- Verifying all the replacement BBUs are the same version.

When a CGR 1240 operates with different BBU versions, it may result in misbehavior in the BBU functionality. This condition is seen in CGR 1240s installed with either Cisco IOS or Cisco CG-OS software.

Note: If you are installing a second or third BBU, follow the steps in [Installing BBU 1 or BBU 2, page 154](#).

To install BBU 0 (the first BBU) in the router:

1. Power down the router completely.

For more information:

<http://www.cisco.com/en/US/docs/routers/connectedgrid/cgr1000/hardware/cgr1240/power.off.html>

2. Open the chassis.

For more information:

<http://www.cisco.com/en/US/docs/routers/connectedgrid/cgr1000/hardware/cgr1240/chassis.html>

3. Remove the BBU cable (from BBU 0, if present).

4. Install the new BBU.

5. Connect the BBU cable to the newly installed BBU.

6. Close the router chassis.

For more information:

<http://www.cisco.com/en/US/docs/routers/connectedgrid/cgr1000/hardware/cgr1240/chassis.html>

7. Reconnect the router to AC power.

For more information:

<http://www.cisco.com/en/US/docs/routers/connectedgrid/cgr1000/hardware/cgr1240/cabling.html#wp1054345>

Installing BBU 1 or BBU 2

Note: When you replace a BBU in the CGR 1240, we highly recommend:

- Replacing all the BBUs.
- Verifying all the replacement BBUs are the same version.

When a CGR 1240 operates with different BBU versions, it may result in misbehavior in the BBU functionality. This condition is seen in CGR 1240s installed with either Cisco IOS or Cisco CG-OS software.

To install BBU 1 or BBU 2 (a second or third BBU) in the router:

1. Open the chassis door by following the steps in [Opening and Closing the Router Chassis, page 75](#).
2. Align the BBU so that the locating pin and the female battery-to-battery connector are facing out and the locating notch is at the top of the router.
3. Slide the locating notch on the new BBU over the locating pin on the installed battery, and verify that the BBU male connector on the new BBU is aligned with the female connector on the installed BBU.
4. Press firmly against the new BBU to seat the connectors and connect the new BBU to the installed BBU.
5. Use your hand to loosely and evenly tighten the six captive screws on the new BBU into the corresponding six threaded connectors on the installed BBU.
6. Use the #1 Phillips screwdriver to tighten the screws to the installed BBU using 7-9 in-lbs of torque

-
7. Verify that the BBU has been successfully installed and is operating normally by viewing the status of the BBU LED. See [Battery Backup Unit LED, page 159](#). The LED displays the following sequence:
 - a. Red fast blinking—BBU is powered on and is initializing.
 - b. Red and green alternate blinking— BBU is synchronizing with the router and the other BBUs.
 - c. The final BBU LED state is one of the following:
 - Blinking amber—BBU detects that there is no AC power supplied to the router and begins discharging (supplying power to the router).
 - Blinking green—The BBU was not fully charged when installed and is charging to full capacity. The router is powered by the AC power supply.
 - Solid green—The BBU is fully charged. The router is powered by the AC power supply.
 8. Close the chassis door by following the steps in [Opening and Closing the Router Chassis, page 75](#).

Disabling and Enabling the BBU in the Router

The BBU automatically begins to supply power to the router when it detects that power is not being received from the AC power supply. You may wish to disable and enable the BBU for the following reasons:

- To inhibit the BBU discharge during storage, shipping or transportation in order to preserve battery life.
- To replace the battery in an installed and operating router.

The BBU can be disabled and enabled by using a hardware approach or by using software command line interface (CLI) commands.

- [Disabling the BBU, page 155](#)
- [Enabling the BBU, page 157](#)

Disabling the BBU

- [Disabling the BBU via Hardware, page 155](#)
- [Disabling the BBU via the CLI, page 156](#)

Note: The default setting is the BBU becomes enabled when it is connected to the router BBU cable.

Disabling the BBU via Hardware

To disable the BBU via hardware, use the following method:

Disable the BBU via BBU Cable Connector on the Router Cable Harness

1. Open the chassis door by following the steps in [Opening the Router Door, page 75](#).
2. Locate the BBU cable connector attached to the base of BBU 1. Find the latch on the underside of the connector. Press the tab of the latch and pull it to disconnect the connector from BBU 1.
3. Tuck the BBU connector into the chassis door to prevent any interference with the closure of the door.
4. Close the chassis door by following the steps in [Closing the Door, page 78](#).

Disabling the BBU via the CLI

Different BBU functionality can be disabled via the CLI:

- Disable the BBU discharge—for example, to inhibit the BBU discharge during storage, shipping or transport in order to preserve battery life.
- Disable the BBU operation—for example, to replace the battery in an installed and operating router.

The CLI operations are detailed in the following sections:

- [Disabling the BBU Discharge in a Cisco CG-OS Router, page 156](#)
- [Disabling the BBU Discharge in a Cisco IOS Router, page 156](#)
- [Disabling the BBU Operation in a Cisco CG-OS Router, page 156](#)
- [Disabling the BBU Operation in a Cisco IOS Router, page 157](#)

Disabling the BBU Discharge in a Cisco CG-OS Router

Note: Disable the BBU discharge—for example, during storage, shipping or transportation, in order to preserve battery life.

Note: When the BBU discharge is disabled by the **backup-battery inhibit discharge command**, the BBU does not charge, even if it is connected to AC power. The BBU discharge must be enabled by the **backup-battery un-inhibit discharge command**, and the BBU connected to AC power, for the BBU to charge.

To disable the BBU discharge in a Cisco CG-OS router:

1. Connect the router to an AC power source.
2. Enter the **backup-battery inhibit discharge** EXEC command:

```
CGR1240# backup-battery inhibit discharge
```

See [backup-battery inhibit discharge, page 163](#).

Disabling the BBU Discharge in a Cisco IOS Router

Note: Disable the BBU discharge—for example, during storage, shipping or transportation, in order to preserve battery life.

Note: When the BBU discharge is disabled by the **backup charge-discharge disable command**, the BBU does not charge, even if it is connected to AC power. The BBU discharge must be enabled by the **backup charge-discharge enable command**, and the BBU connected to AC power, for the BBU to charge.

To disable the BBU discharge in a Cisco IOS router:

1. Connect the router to an AC power source.
2. Enter the **backup charge-discharge disable** EXEC command:

```
CGR1240# battery charge-discharge disable
```

See [battery charge-discharge, page 164](#).

Disabling the BBU Operation in a Cisco CG-OS Router

Note: Disable the BBU operation—for example, when a battery is due for replacement in an installed and operational router.

To disable the BBU operation in a Cisco CG-OS router:

1. Connect the router to an AC power source.
2. Enter the **backup-battery disable** EXEC command:

```
CGR1240# backup-battery disable
```

See [backup-battery disable, page 162](#).

Disabling the BBU Operation in a Cisco IOS Router

Note: You cannot disable BBU operation using the CLI on routers using the Cisco IOS operating system. You can only disable BBU operation using the CLI on routers using the Cisco CG-OS operating system.

Enabling the BBU

- [Enabling the BBU via Hardware, page 157](#)
- [Enabling the BBU via the CLI, page 157](#)

Note: The default setting is the BBU becomes enabled when it is connected to the router BBU cable.

Enabling the BBU via Hardware

To enable the BBU (depending on the method used):

- [Enable the BBU via BBU Cable Connector on the Router Cable Harness, page 157](#)

Enable the BBU via BBU Cable Connector on the Router Cable Harness

1. Open the chassis door by following the steps in [Opening the Router Door, page 75](#).
2. Locate the BBU cable connector in the chassis door. Find the socket on the base of BBU 1. With the latch of the connector facing the chassis door, press the connector into the socket.
3. Tuck the router cable harness into the chassis door to prevent any interference with the closure of the door.
4. Close the chassis door by following the steps in [Closing the Door, page 78](#).

Enabling the BBU via the CLI

The default setting is the BBU becomes enabled when it is connected to the router BBU cable. If the BBU is disabled for any reason, you may need to enable it once more.

Different BBU functionality can be enabled via the CLI:

- Enable the BBU discharge—for example, used to reenable the BBU discharge after storage, shipping or transport in order to resume battery discharge.
- Enable the BBU operation—for example, used to enable a replacement battery in an installed and peritoneal router.

The CLI operations are detailed in the following sections:

- [Enabling the BBU Discharge in a Cisco CG-OS Router, page 158](#)
- [Enabling the BBU Discharge in a Cisco IOS Router, page 158](#)
- [Enabling the BBU Operation in a Cisco CG-OS Router, page 158](#)

-
- [Enabling the BBU Operation in a Cisco IOS Router, page 158](#)

Enabling the BBU Discharge in a Cisco CG-OS Router

Note: Enable the BBU discharge—for example, if it is in a disabled state after storage, shipping or transportation.

Note: When the BBU discharge is disabled by the **backup-battery inhibit discharge command**, the BBU does not charge, even if it is connected to AC power. The BBU discharge must be enabled by the **backup-battery un-inhibit discharge command**, and the BBU connected to AC power, for the BBU to charge.

To enable the BBU discharge in a Cisco CG-OS router:

1. Connect the router to an AC power source.
2. Enter the **backup-battery un-inhibit discharge EXEC** command:

```
CGR1240# backup-battery un-inhibit discharge
```

See [backup-battery inhibit discharge, page 163](#).

Enabling the BBU Discharge in a Cisco IOS Router

Note: Enable the BBU discharge—for example, if a BBU is in a disabled state after storage, shipping or transportation.

Note: When the BBU discharge is disabled by the **backup charge-discharge disable command**, the BBU does not charge, even if it is connected to AC power. The BBU discharge must be enabled by the **backup charge-discharge enable command**, and the BBU connected to AC power, for the BBU to charge.

To enable the BBU discharge in a Cisco IOS router:

1. Connect the router to an AC power source.
2. Enter the **backup charge-discharge enable EXEC** command:

```
CGR1240# battery charge-discharge enable
```

See [battery charge-discharge, page 164](#).

Enabling the BBU Operation in a Cisco CG-OS Router

Note: Enable the BBU operation—for example, after a replacement BBU is placed in an installed and operational router.

To enable the BBU operation in a Cisco CG-OS router:

1. Connect the router to an AC power source.
2. Enter the **backup-battery enable EXEC** command:

```
CGR1240# backup-battery enable
```

See [backup-battery enable, page 162](#).

Enabling the BBU Operation in a Cisco IOS Router

Note: You cannot enable the BBU operation using the CLI on routers using the Cisco IOS operating system. You can only enable the BBU operation using the CLI on routers using the Cisco CG-OS operating system.

Working with the BBU in Transportation Mode

There are some discrepancies between the CLI commands and the NMS that could cause a BBU failure.

Two commands, `do no battery transportation-mode` and `do battery charge-discharge enable`, do not work from the NMS. The NMS reports the device configuration push was successful, and the re-registration was successful, however the settings remain unchanged on the router.

Ensure that when you are using a BBU that you make sure the configuration is correct using the CLI. For example:

```
CGR1240#[no] battery transportation-mode
```

When the router has the transportation-mode set, inhibit discharge is enabled when AC is ON and inhibit discharge is disabled when AC is OFF. So, effectively the battery can be charged, but does not discharge.

The transportation mode status is shown in the show platform battery output:

```
CGR1240#show platform battery
Battery level 2% (0:08), Charging (Transportation mode)
```

```
CGR1240#show platform battery unit
Battery pack state: Operational (Transportation mode)
```

Battery unit	0	1	2
Status	Charging	Empty	Empty
Charge and Discharge	enabled	enabled	enabled
Charge level	7 %	0 %	0 %
Capacity Remaining (mAh)	313	0	0
Full Charge Capacity (mAh)	5739	5739	5739
Voltage	10506	10222	10171
Current	845	0	0
Temperature	30	31	29
Firmware version	1224	1224	1224

The transportation mode overrides the charge bit to enable it. Therefore, if the battery charge-discharge bit was previously disabled, it enables charge and the charge-discharge disable cli becomes redundant.

Transportation mode setting is persistent on system reload.

Battery Backup Unit LED

The BBU features a single LED that indicates the status of the BBU when it is installed in the router.

Figure 94 Battery Backup Unit LED Location

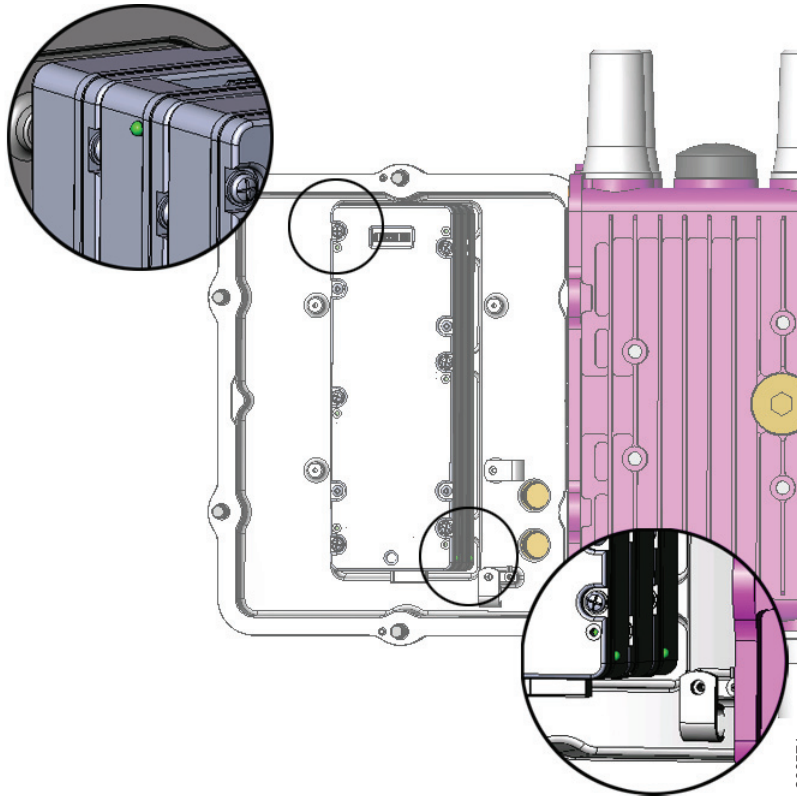

LED	Color and State	Description
BBU	Green solid	Idle state
	Green blinking	Charging
	Amber blinking	Discharging (providing power to the system)
	Amber slow blinking	Disabled with the system software
	Red/green blinking	Initializing
	Red fast blinking	Resetting
	Red blinking	Bootloader mode
	Red slow blinking	Test mode
	Red solid	BBU failure
	Off	Disabled (disconnected from router or completely discharged)

Related Commands

- [CG-OS Battery BBU Commands, page 161](#)
- [Cisco IOS BBU Commands, page 164](#)

CG-OS Battery BBU Commands

This section describes the battery backup commands for routers using the Cisco CG-OS operating system, including:

- [backup-battery firmware upgrade, page 161](#)
- [show environment power, page 161](#)
- [backup-battery enable, page 162](#)
- [backup-battery disable, page 162](#)
- [backup-battery reset, page 162](#)
- [backup-battery hard-reset, page 162](#)
- [backup-battery inhibit discharge, page 163](#)
- [poweroff module number backup-battery, page 163](#)

backup-battery firmware upgrade

Note: The **backup-battery firmware upgrade** command only works on routers using the Cisco CG-OS operating system.

To upgrade the BBU firmware, use the **backup-battery firmware upgrade** EXEC command in user EXEC mode:

```
CGR1240# backup-battery firmware upgrade
```

When this command is issued, the firmware upgrade is executed in the background and a syslog message is displayed when the upgrade is complete.

To view the status of the BBU firmware download during the upgrade process, use the **show environment power** EXEC command in user EXEC mode. See [show environment power, page 161](#).

show environment power

Note: The **show environment power** command only displays both the power statistical data and the battery backup status on routers using the Cisco CG-OS operating system. The command only displays the power statistical data on routers using the Cisco IOS operating system.

To display the power statistical data and battery backup status, use the **show environment power** command in user EXEC mode:

```
CGR1240# show environment power
```

A sample output from this command is:

```
Power Supply Summary:
-----
AC Voltage: 116.00Volts
AC Current: 0.31Amps
DC Voltage: 11.98Volts
DC Current: 0.95Amps
Hotspot 1 temperature: 38.25C
Hotspot 2 temperature: 50.25C

Backup Battery Status:
-----
BBU State :
```

Backup Battery Not Present

The power supply summary section provides power data for the router and the backup battery status section provides status information on the BBU's presence.

backup-battery enable

Note: The **backup-battery enable** command only works on routers using the Cisco CG-OS operating system.

To enable the BBU operation via the CLI, use the **backup-battery enable** command in user EXEC mode:

```
CGR1240# backup-battery enable
```

The default setting is the BBU becomes enabled when it is connected to the router BBU cable. The BBU automatically waits to detect that power is not being received from the AC power supply, and then begins to supply power to the router.

You can use the **backup-battery enable** command after a battery has been disabled and replaced in an installed and operational router, to reenable the replacement battery. When the BBU is enabled, the BBU LED appears on, and reflects the BBU operating state (idle, charging, discharging etc.).

Once the BBU is connected, the only way to disable is to use the **backup-battery disable** command. To enable the BBU again, issue the **backup-battery enable** command.

backup-battery disable

Note: The **backup-battery disable** command only works on routers using the Cisco CG-OS operating system.

To disable the BBU operation via the CLI, use the **backup-battery disable** command in user EXEC mode:

```
CGR1240# backup-battery disable
```

The default setting is the BBU becomes enabled when it is connected to the router BBU cable. The BBU automatically waits to detect that power is not being received from the AC power supply, and then begins to supply power to the router.

You can use the **backup-battery disable** command to disable a battery that is in an installed and operational router, and needs to be replaced. When the BBU is disabled, the BBU LED appears off.

Once the BBU is connected, the only way to disable is to use the **backup-battery disable** command. To enable the BBU again, issue the **backup-battery enable** command.

backup-battery reset

Note: The **backup-battery reset** command only works on routers using the Cisco CG-OS operating system.

To reset the BBU power (power off the BBU, then power it back on), use the **backup-battery reset** command in user EXEC mode:

```
CGR1240# backup-battery reset
```

This command is functional only when AC power is supplying power to the router. If you enter this command when the router is powered by the BBU, an error message is displayed.

This command resets all BBUs installed in the router.

backup-battery hard-reset

Note: The **backup-battery hard-reset** command only works on routers using the Cisco CG-OS operating system.

To reset the BBU power (power off the BBU, then power it back on) while you cannot communicate with the BBU through the UART interface, use the **backup-battery hard-reset** command in user EXEC mode:

CGR1240# **backup-battery hard-reset**

This command resets all BBUs installed in the router.

backup-battery inhibit discharge

Note: The **backup-battery inhibit discharge** command only works on routers using the Cisco CG-OS operating system.

Note: When the BBU discharge is disabled by the **backup-battery inhibit discharge** command, the BBU does not charge, even if it is connected to AC power. The BBU discharge must be enabled by the **backup-battery un-inhibit discharge** command, and the BBU connected to AC power, for the BBU to charge.

To disable the BBU automatic discharge feature, use the **backup-battery inhibit discharge** command in user EXEC mode. Use this command to disable the BBU automatic discharge when you disconnect the router from AC power, and want to prevent the BBU from automatically discharging; for example when you are shipping the router, or transporting it between locations. When the BBU discharge is disabled, the BBU LED displays the amber slow blinking state. Use the **backup-battery un-inhibit discharge** command to enable the BBU automatic discharge after disabling it.

The **backup-battery inhibit discharge** command has two effects:

- With AC power on, the BBU does not charge.
- With AC power off, the BBU does not power the router (the BBU does not discharge).

This command is functional only when the BBU is supplying power to the router. If you enter this command when the router is powered by AC power, an error message is displayed.

Caution: Entering the **backup-battery inhibit discharge** command disables the BBU discharge immediately. You are not prompted to confirm the command. If you enter this command when the router is operating on the network and powered by the BBU, the router will immediately power down and will no longer operate on the network.

To disable the BBU discharge feature:

1. Connect the router to an AC power source.
2. Enter the **backup-battery inhibit discharge** EXEC command:

```
CGR1240# backup-battery inhibit discharge
```

To reset the BBU to the default behavior (automatically begin discharging when the router is not receiving AC power) use the **backup-battery un-inhibit discharge** command:

1. Connect the router to an AC power source.
2. Enter the **backup-battery un-inhibit discharge** EXEC command:

```
CGR1240# backup-battery un-inhibit discharge
```

The **backup-battery un-inhibit discharge** command has two effects:

- With AC power on, the BBU charges.
- With AC power off, the BBU powers the router (the BBU discharges).

poweroff module number backup-battery

Note: The **poweroff module number backup-battery** command only works on routers using the Cisco CG-OS operating system.

To configure the router to power off specific modules (including the integrated Ethernet switch) when the router switches to BBU power, use the **poweroff module *number* backup-battery** command in global configuration mode.

By default, all modules continue to operate normally when the router is powered by the BBU. Enter this command for each module that you want to automatically shut down.

Syntax	Description
poweroff module <i>number</i> backup-battery	Configures the router to power down the indicated module when the router switches to BBU power. <i>number</i> —The number of module that is powered down: <ul style="list-style-type: none">■ 2: Ethernet switch module (all ports)■ 3-6: Module inserted in the slot with corresponding number. Slot numbering is described and illustrated in Router Hardware Description, page 9.

To configure the router to shut down the Ethernet switch (all Ethernet ports) when the router is powered by the BBU, enter this command:

```
CGR1240 (config)# poweroff module 2 backup-battery
```

To configure the router to shut down the module installed in Slot 6 when the router is powered by the BBU, enter this command:

```
CGR1240 (config)# poweroff module 6 backup-battery
```

Use the **no** form of the command to reset a module to the default behavior: continue to operate normally when the router switches to BBU power. For example:

```
CGR1240 (config)# no poweroff module 2 backup-battery
```

For detailed information on configuring the router, including configuration modes and saving configurations, see the router software configuration guides on Cisco.com, at: www.cisco.com/go/cgr1000-docs

Cisco IOS BBU Commands

- [battery charge-discharge, page 164](#)
- [show platform battery, page 165](#)
- [show environment power, page 170](#)

battery charge-discharge

Note: The **battery charge-discharge** command only works on routers using the Cisco IOS operating system.

Note: When the BBU discharge is disabled by the **battery charge-discharge disable command**, the BBU does not charge, even if it is connected to AC power. The BBU discharge must be enabled by the **battery charge-discharge enable command**, and the **BBU connected to AC power, for the BBU to charge**.

To change the enabled status of the BBU automatic discharge feature, use the **battery charge-discharge** command in user EXEC mode. The command syntax is:

```
battery charge-discharge {enable | disable}
```

The default behavior of the BBU is to automatically begin discharging when the router is not receiving AC power.

Use the **battery charge-discharge disable** command to disable the BBU automatic discharge when you disconnect the router from AC power, and want to prevent the BBU from automatically discharging; for example when you are shipping the router, or transporting it between locations. When the BBU discharge is disabled, the BBU LED displays the amber slow blinking state. Use the **battery charge-discharge enable** command to enable the BBU automatic discharge after disabling it.

The **battery charge-discharge disable** command has two effects:

- With AC power on, the BBU does not charge.
- With AC power off, the BBU does not power the router (the BBU does not discharge).

This command is functional only when the BBU is supplying power to the router. If you enter this command when the router is powered by AC power, an error message is displayed.

Caution: Entering the **battery charge-discharge disable** command disables the BBU discharge immediately. You are not prompted to confirm the command. If you enter this command when the router is operating on the network and powered by the BBU, the router will immediately power down and will no longer operate on the network.

To reset the BBU to the default behavior (automatically begin discharging when the router is not receiving AC power), use the **battery charge-discharge enable** command.

The **battery charge-discharge enable** command has two effects:

- With AC power on, the BBU charges.
- With AC power off, the BBU powers the router (the BBU discharges).

To disable the BBU discharge feature:

1. Connect the router to an AC power source.
2. Enter the **battery charge-discharge disable** EXEC command:

```
CGR1240# battery charge-discharge disable
```

To enable the BBU discharge feature:

1. Connect the router to an AC power source.
2. Enter the **battery charge-discharge enable** EXEC command:

```
CGR1240# battery charge-discharge enable
```

show platform battery

Note: The **show platform battery** command only works on routers using the Cisco IOS operating system.

To display battery data information, use the **show platform battery** command in user EXEC mode. The command syntax is:

```
show platform battery [brief | cable | details | short | sprom | unit]
```

Syntax Description

brief	(Optional) Displays summary information about the battery charge level in percentage and hours:minutes format, as well as the battery charge state: <ul style="list-style-type: none">■ Idle, if > 85%■ Charging, if voltage > 10.5 V and charge value < 85%.■ Discharging, if battery is main source of power.■ Empty, if battery is drained out of charge.
cable	(Optional) Displays details about the battery cable status: <ul style="list-style-type: none">■ present = 0, in the command output means that a battery cable is not present.■ present = 1, in the command output means that a battery cable is present.
details	(Optional) Displays troubleshooting information about the battery by presenting a range of summary information about the battery characteristics.
short	(Optional) Displays backup battery information in short format (formatted for a management device).
sprom	(Optional) Displays troubleshooting information based on the EEPROM details of the battery unit.
unit	(Optional) Displays a range of battery charge, capacity, and parameter information including: <ul style="list-style-type: none">■ battery charge state and charge value/level in percent.■ capacity (remaining and full charge).■ voltage and current levels.■ firmware version details.

The following are examples of the command, with sample output:

```
CGR1240# show platform battery
```

```
Battery is not present  
Battery pack state: Not available
```

The command output indicates a battery is not present.

```
CGR1240# show platform battery brief
```

```
Battery level 92% (12:27), Idle
```

The command output indicates that the battery is charged to a 92% level, has q2 hours and 27 minutes battery life available, and is in an idle state.

```
CGR1240# show platform battery cable
```

```
Status register 0x16  
Present ..... 1  
Ready state .. 1  
Ready bit .... 1  
Interrupt .... 0  
Reset ..... 0  
Power register 0x3F13  
AC ..... 1
```

The command output indicates that a battery cable is connected up (Present.....1). The output represents a well-connected functional cable.

```
CGR1240# show platform battery details
```

```
Battery pack state: Operational
```

```
Battery pack state: Operational
```

Battery unit	0	1	2
BatteryStatus	0x80	0xA0	0x80
UnitStatus	0x5830	0x4801	0x2802
BootloaderStatus	0xB	0xB	0xB
InterruptStatus	0x0	0x0	0x0
ChargeStatus	0xC010	0xC010	0xC010
ControlOverride	0x0	0x0	0x0
AbsoluteStateOfCharge ...	89 %	97 %	90 %
RelativeStateOfCharge ...	89 %	97 %	90 %
RemainingCapacity .. (mAh)	5124	5601	5221
FullChargeCapacity . (mAh)	5739	5739	5739
AverageTimeToEmpty . (min)	65535	65535	65535
AverageTimeToFull .. (min)	65535	65535	65535
RunTimeToEmpty	65535	65535	65535
AtRateTimeToFull ... (min)	65535	65535	65535
AtRateTimeToEmpty .. (min)	65535	65535	65535
AtRateOK	1	1	1
Voltage	11669 (mV)	11913	11721
Current	0 (mA)	0	0
AverageCurrent	0 (mA)	0	0
ChargingCurrent	0 (mA)	0	0
ChargingVoltage	11669 (mV)	11913	11721
CycleCount	1	6	6
ChargeAlarmWarning	128	160	128
HeaterAndStatusControl ...	0	0	0
HeaterTemperature ... ('C)	30	31	30
AmbientTemperature .. ('C)	29	30	29
Temperature	30 ('C)	31	30
Firmware version	5213	5213	5213

```
UART delay stats rx=2772us, tx=23us
```

```
Total charge .....
```

```
Low level .....
```

```
Average time to empty (hh:mm) 12:28
```

```
Last time to empty readings ( 751 751 746 751 742 minutes )
```

```
Needs firmware upgrade .....
```

```
Firmware upgd failures .....
```

```
Power-off module when running on battery:
```

```
Module 3 .....
```

```
Module 4 .....
```

```
Module 5 .....
```

```
Module 6 .....
```

The command output has a range of battery status information including charge capacity, voltage and current levels, temperature, time data, and firmware information.

```
router# show platform battery short
```

```
AC power supply .....
```

```
Battery present .....
```

```
Battery ready .....
```

```
Number of battery units . 3
```

```
Time to empty .....
```

Unit#	Charge	Time to empty	State	Firmware	Charge and discharge
0	86 %	4:35	Idle	1224	enabled
1	82 %	4:26	Idle	1224	enabled
2	60 %	3:13	Idle	1224	enabled

The command output displays backup battery summary information in short format (formatted for a management device).

```
router# show platform battery sprom
```

```
Battery unit 0
SPROM:
Common block:
FRU Major Type : 0xAB05
FRU Minor Type : 0x0
OEM String     : Cisco Systems, Inc.
Product Number : CGR-BATT-4AH
Serial Number  : NVT17244415
Part Number    : 74-10147-02
Part Revision  : 01
Mfg Deviation  :
H/W Version    : 6.0
Mfg Bits       : 0
Engineer Use   : 0
snmp OID       : 1.9.12.3.1.9.91.12
Power Consump  : 0
CLEI Code      :
VID            : V00
Battery specific block:
Vendor name    : NVT
Vendor product number : 1132-20D802-1CB
Vendor revision number : AAAA
Vendor sequence number : 7
Date code     : 06192013R6
Build version : R6
Output power max : 40
Input power max : 20
BBU chemistry  : Li-ion
Cells in series : 3
Firmware version : 3
Firmware revision : 5213
Min discharge temp : 0
Max discharge temp : 253
Min charging temp : 333
Max charging temp : 273
Output current max : 323
Output voltage max : 400
```

```
Battery unit 1
SPROM:
Common block:
FRU Major Type : 0xAB05
FRU Minor Type : 0x0
OEM String     : Cisco Systems, Inc.
Product Number : CGR-BATT-4AH
Serial Number  : ATL16240813
Part Number    : 74-10147-01
Part Revision  : A0
Mfg Deviation  :
H/W Version    : 0.0
Mfg Bits       : 0
Engineer Use   : 0
snmp OID       : 1.9.12.3.1.9.91.12
Power Consump  : 0
```

```
CLEI Code      :  
VID            : V01  
Battery specific block:  
Vendor name    : ATL  
Vendor product number :  
Vendor revision number : 0000  
Vendor sequence number : 71  
Date code     : 06162012R4A  
Build version  : R4A  
Output power max : 40  
Input power max : 20  
BBU chemistry  : Li-ion  
Cells in series : 3  
Firmware version : 3  
Firmware revision : 2082  
Min discharge temp : 1  
Max discharge temp : 253  
Min charging temp : 333  
Max charging temp : 273  
Output current max : 323  
Output voltage max : 400
```

```
Battery unit 2  
SPROM:  
Common block:  
FRU Major Type : 0xAB05  
FRU Minor Type : 0x0  
OEM String     : Cisco Systems, Inc.  
Product Number : CGR-BATT-4AH  
Serial Number  : ATL16240723  
Part Number    : 74-10147-01  
Part Revision  : A0  
Mfg Deviation  :  
H/W Version    : 0.0  
Mfg Bits       : 0  
Engineer Use   : 0  
snmpOID        : 1.9.12.3.1.9.91.12  
Power Consump  : 0  
CLEI Code      :  
VID            : V01  
Battery specific block:  
Vendor name    : ATL  
Vendor product number :  
Vendor revision number : 0000  
Vendor sequence number : 25  
Date code     : 06162012R4A  
Build version  : R4A  
Output power max : 40  
Input power max : 20  
BBU chemistry  : Li-ion  
Cells in series : 3  
Firmware version : 3  
Firmware revision : 2082  
Min discharge temp : 1  
Max discharge temp : 253  
Min charging temp : 333  
Max charging temp : 273  
Output current max : 323  
Output voltage max : 400
```

The command output shows the EEPROM summary information for battery backup units 0, 1, and 2 that is used to troubleshoot the battery.

```
CGR1240# show platform battery unit
```

```
Battery pack state: Operational
```

Battery unit	0	1	2
Status	Idle	Full	Idle
Charge level	89 %	97 %	90 %
Capacity Remaining (mAh)	5124	5596	5221
Full Charge Capacity (mAh)	5739	5739	5739
Voltage	11673	11913	11721
Current	0	0	0
Temperature	30	31	30
Firmware version	5213	5213	5213

The command output displays a range of charge, capacity, and parameter information for battery backup units 0, 1, and 2. The firmware version is version 5219.

show environment power

Note: The **show environment power** command only displays the power statistical data on routers using the Cisco IOS operating system. The command displays both the power statistical data and the battery backup status on routers using the Cisco CG-OS operating system.

To display the power statistical data, use the **show environment power** command in user EXEC mode:

```
CGR1240# show environment power
```

A sample output from this command is:

```
AC voltage ..... [V] 116.000
AC current ..... [A] 0.609
DC voltage ..... [V] 11.937
DC current ..... [A] 1.468
Hotspot#1 temperature ['C] 33
Hotspot#2 temperature ['C] 50
```

The command output has power supply summary information that provides power data for the router.

BBU Technical Specifications

This section describes the specifications and standards supported by the BBU.

Note: For BBU connector and cable specifications, see [Connector and Cable Specifications, page 195](#).

- [Router Power Path Selection, page 170](#)
- [Discharge Conditions, page 171](#)
- [Charge Conditions, page 171](#)
- [Operating and Storage Temperatures, page 172](#)
- [Battery Life, page 172](#)

Router Power Path Selection

During normal operation, the router is powered by the integrated AC power supply. The BBU enters discharge mode and begins providing power to the router when the AC power is interrupted outside a range of 85V to 250V for more than 20 ms. The BBU charges or discharges only; it does not support both simultaneously.

Discharge Conditions

Table 28 Battery Backup Unit–Discharging Specifications

Discharge Conditions	Description
Power load	10 W
Duration	4 hours
Entry to discharge ¹	<ul style="list-style-type: none"> ■ BBU cable harness is installed ■ AC power (range of 85V to 250V) not detected for more than 20 ms ■ Remaining BBU capacity >5% ■ External ambient temperature is within -40 to 122° F (-40 to 50° C)
Exit discharge ²	<ul style="list-style-type: none"> ■ AC power restored in the range of 85V to 250V for more than 20 ms. ■ Remaining BBU capacity <5% ■ External ambient temperature is outside ranging -40 to 122° F (-40 to 50° C)
¹ All conditions met.	
² Any condition met and system is detected.	

Charge Conditions

Table 29 Battery Backup Unit–Charge Specifications

Charge Conditions	Description
Power draw	No more than 20 W when charging
State of charge	No more than 90%
Entry to charging limit ¹	<ul style="list-style-type: none"> ■ BBU cable harness is installed ■ Charge is enabled ■ State of Charge (SOC) <85% ■ AC power detected in the range of 85V to 250V for more than 20 ms. ■ External ambient temperature is within -4 to 104° F (-20 to 40° C)
Exit charging ²	<ul style="list-style-type: none"> ■ BBU cable harness not installed ■ Charge is disabled ■ AC power (range of 85V to 250V) not detected for more than 20 ms. ■ External ambient temperature is outside ranging -4 to 104° F (-20 to 40° C)
¹ All conditions met.	
² Any condition met and system is detected.	

Operating and Storage Temperatures

Table 30 Battery Backup Unit—Operating and Storage Temperatures

BBU State	Local BBU Internal Temperature	External Ambient Temperature
Charging	+32 to 122° F (0 to 50° C)	-4 to 104° F (-20 to 40° C)
Discharging	-4 to 140° F (-20 to 60° C)	-40 to 122° F (-40 to 50° C)
Operation (Idle)	-4 to 185° F (-20 to 85° C)	-40 to 158° F (-40 to 70° C)
Storage and shipping	+14 to 113° F (-10 to 45° C) for 3 months maximum	Short-term: +14 to 113° F (-10 to 45° C) for 3 months maximum Long-term: +27 to 77° F (-3 to 25° C) - 65% Relative Humidity - 40 to 90% SOC

Battery Life

Table 31 Battery Backup Unit – Battery Life

Product ID	Battery Life	Charge-Discharge Cycles
CGR-BATT-4AH	5 years	500



Installing External Non-Cisco Modules

This section explains how the Cisco 1240 Connected Grid Router (CGR 1240 or router) provides support for a compatible, external non-Cisco wireless modules, installed on the router exterior and connected to the router integrated switch module. Wireless connections send data from the router to field devices, such as meters, sensors, and Intelligent Electronic Devices (IEDs), and from the router to the utility or data management center.

These topics are discussed:

- [External Non-Cisco Module Support, page 173](#)
- [Before Installing, page 174](#)
- [Install an External Non-Cisco Module, page 175](#)
- [Related Information, page 180](#)

External Non-Cisco Module Support

This section describes the support for, and requirements for, installing a non-Cisco module on the router.

Caveats

- Cisco does not provide technical support for issues related to non-Cisco products. You must contact the module supplier or your reseller to obtain technical support for the non-Cisco module.
- Installing a module that does not meet the requirements described in this section can negatively affect router performance.
- The router system software does not communicate with or interact with non-Cisco modules.
- A non-Cisco module that is installed on the router does not interact with the router chassis. Connecting a non-Cisco module to the router does not certify the module. Before installing the module, verify that it is certified for use in your environment.

External Non-Cisco Module Requirements

Non-Cisco modules installed on the router exterior must meet the following requirements:

- Compliance with Type 4X and IP67 standards.
- Support the router mounting boss dimensions (see [Figure 96 on page 177](#)).

Cable Requirements

Cables used for installing an external, non-Cisco module should meet the following criteria:

- Outdoor-rated
- UV-stabilized

-
- Diameter of 0.20–0.35 inches (5.08–8.89 mm)

Caution: Cables must be a minimum of 0.20 in. in diameter to create an adequate seal within the cable glands. Using smaller cables could result in an inadequate seal and expose the router interior to environmental elements.

- **Power cable**—The cable that you provide to connect the module to the router 12V power connector must be wired so that Pin 3 (cable presence) and Pin 4 (ground) are connected to each other. If they are not connected, the module will not detect power from the router. Refer to [External Non-Cisco Module Support, page 173](#).

Online Installation and Removal

An external non-Cisco module can be installed or removed while the router is installed (usually on a pole top) and operating normally.

The module must be powered off until it is connected to a power source as part of the installation process described in this section. Power sources can include:

- Router Power over Ethernet (PoE) Ethernet port (see [Router Hardware Description, page 9](#))
- Router 12V power connector, illustrated and described in [Figure 98 on page 180](#)
- External-to-the-router power source

Power

The router interior features a 4-pin, Micro-Fit 3.0 connector, which provides 12 volts of power to an externally-connected module. See [Figure 98 on page 180](#) for an illustration of the power connector.

Before Installing

Read this section and [Installation Safety and Site Preparation, page 3](#) before following any installation procedures.

Prepare the Installation Site

The installation site must be prepared according to [Installation Safety and Site Preparation, page 3](#).

Preventing Electrostatic Discharge Damage

Many of the components discussed in this chapter are sensitive to electrostatic discharge (ESD) damage, which can occur when electronic cards or components are handled improperly, results in complete or intermittent failures.

To prevent ESD damage, follow these guidelines:

- Always use an ESD wrist or ankle strap and ensure that it makes good skin contact.
- Connect the equipment end of the strap to an unfinished chassis surface.
- Place the removed memory card on an antistatic surface or in a static shielding bag. If the card will be returned to the factory, immediately place it in a static shielding bag.
- Avoid contact between the card and clothing. The wrist strap protects the card from ESD voltages on the body only; ESD voltages on clothing can still cause damage.
- Do not remove the wrist strap until the installation is complete.

Cabling Guidelines

Follow these guidelines for using cables with the router:

- Position cables so that they do not place strain on the router connectors.
- Organize cables into bundles when necessary to avoid intertwining.
- Inspect cables to ensure adequate routing and bend radius.
- Install cable ties that comply with your site requirements.

Install an External Non-Cisco Module

This section provides information for connecting an external, non-Cisco module to the router. Some steps might require referring to the module documentation. This section includes these installation topics:

- [Tools and Materials You Supply, page 175](#)
- [Open and Close the Router Door, page 175](#)
- [Connect the Module to the Chassis, page 175](#)
- [Cabling Instructions, page 177](#)
- [Connect to the Network, page 178](#)
- [Connect to Power, page 179](#)

Tools and Materials You Supply

- **Wrench**—You must supply a 13-mm box-end wrench or socket set to remove port plugs from the cable ports and a 15/16-inch open-end wrench to install the cable glands on the cable ports.
- **Hardware**—You must provide any hardware as required in [Connect the Module to the Chassis, page 175](#).
- **Power Connector Adapter**—Depending on your module power cable, you might need to provide an adapter to connect the module to the router 4-pin Micro-Fit 3.0 power connector.

Caution: The housing for any power connector adapter that you supply must comply with the UL 94 V-1 flammability standard.

Open and Close the Router Door

You might be required to open the router door to install the module (see [Opening and Closing the Router Chassis, page 75](#)).

Connect the Module to the Chassis

The router front door has these features for installing a module on the router exterior:

- Six mounting bosses for attaching a module to the router (see **1** in [Figure 95 on page 176](#))
- Two cable ports to thread power and Ethernet cables to the router interior (see **2** in [Figure 95 on page 176](#))

To attach the module to the mounting bosses, you must:

- Provide the hardware required to attach the module to the mounting bosses
- Follow the mounting instructions that support the module

Figure 95 Mounting Bosses and Cable Ports

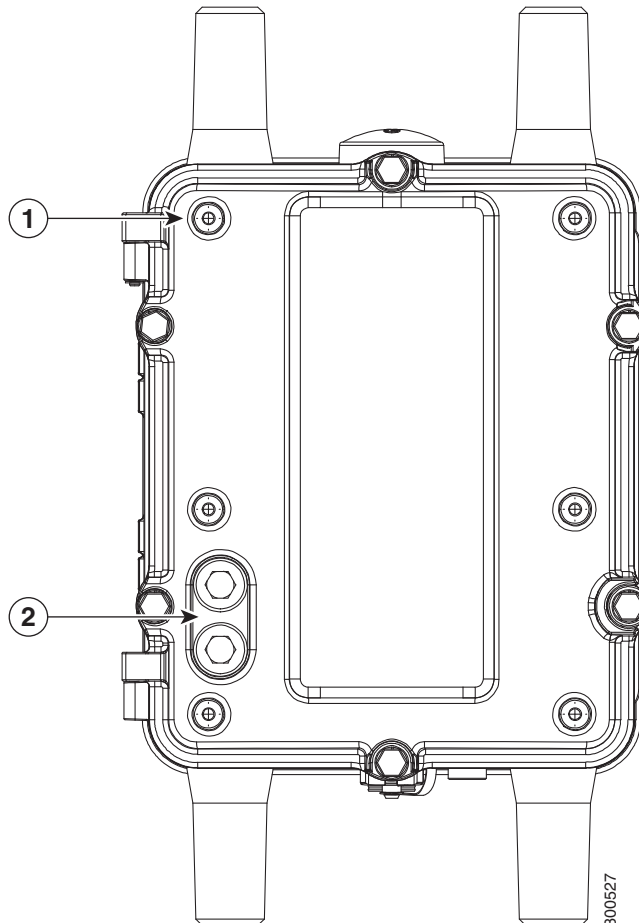

Item	Description	Qty.
1	Mounting bosses (M8 x 1.25), for attaching non-Cisco module to the router.	6
2	Cable ports, for threading module cables to ports on the router interior.	2

Installation Options

The layout of the six mounting bosses on the router front door supports two installation options:

- [External Cabling, page 177](#)
- [Internal Cabling, page 178](#)

The installation option you choose depends on the dimensions of the module you are attaching, and the cable location on the module.

[Figure 96 on page 177](#) shows all six mounting bosses on the router, and the corresponding dimensions.

Figure 96 Dimensions for Mounting External Non-Cisco Modules

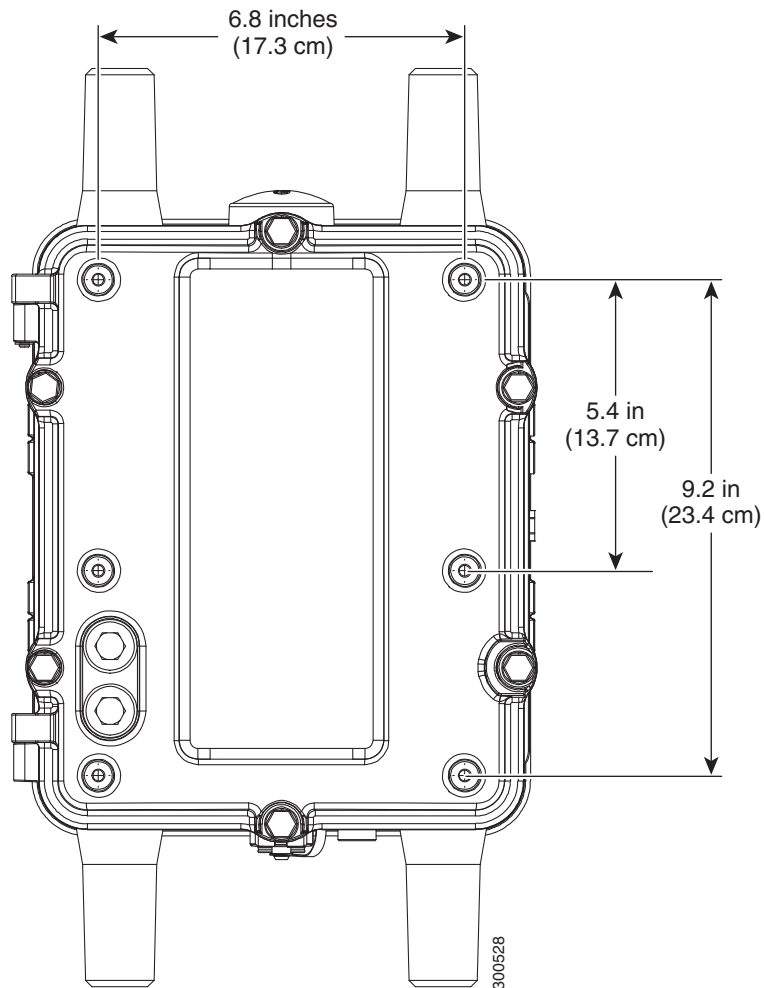

Cabling Instructions

This section describes the two cabling procedures. Use the procedure that applies to your installation configuration:

- [External Cabling, page 177](#)
- [Internal Cabling, page 178](#)

External Cabling

Depending on the dimensions of the module, you might have to connect the module to the router in a way that the cables are exposed outside the router and the module.

With this configuration:

- Cables are exposed externally
- Use cable glands to thread cables through the cable ports
- Follow the cabling instructions in this section

Cisco Cable Glands

When you install the module in a configuration that uses external cabling from the module through the cable ports on the router door, you must provide cable glands for each cable port.

Cable glands:

- Create seal to protect the router interior from environmental elements
- Can be ordered from Cisco: CGR-IP67GLAND (one cable gland per kit)
- See [Cable Glands Description, page 97](#)

Caution: The cable glands must be used for all cables that are threaded through the router chassis cable ports to prevent exposing the router interior to environmental elements.

Outdoor Cable Requirements

Verify that the cables you use to connect the module to the router meet the cable requirements described in [Cable Requirements, page 97](#).

Connecting the Cable Glands

To connect the cable glands to a router cable port:

1. Use the 13-mm wrench to remove the port plugs from the cable ports on the router door.
2. Follow the steps in [Cable Glands Installation Steps, page 98](#) to:
 - Thread the Ethernet and power cables through the cable glands
 - Connect the cable glands to the cable ports on the router door

Internal Cabling

Depending on the module dimensions and the location of the module cables, you may be able to install the module directly over the cable ports and thread the module cables through the cable ports.

With this configuration:

- Cables are not exposed externally.
- Install an O-ring in each cable port to create an environment-proof seal.
- Follow the cabling instructions in this section.

Cisco O-Ring

When you install the module in a configuration that uses internal cabling from the module, through the cable ports on the router door, insert a rubber O-ring into each port to create an environmental-proof seal.

Caution: The O-ring must be used to prevent exposing the router interior to environmental elements.

Connect to the Network

1. Verify that the module Ethernet cable is threaded through the router cable port, and that the cable port has cable glands or an O-ring installed.
2. Connect the module Ethernet cable to any of the Ethernet ports on the router interior. See location 1 in [Figure 97 on page 179](#) for router Ethernet port locations.

For detailed information about making router Ethernet connections, see [Connect to the Ethernet Backhaul Network, page 86](#).

3. After connecting the module network cable to the Ethernet port, use the wire ties on the router door (see location 1 in [Figure 98 on page 180](#)) to fix the cable to the door.

Figure 97 Router Ethernet Ports

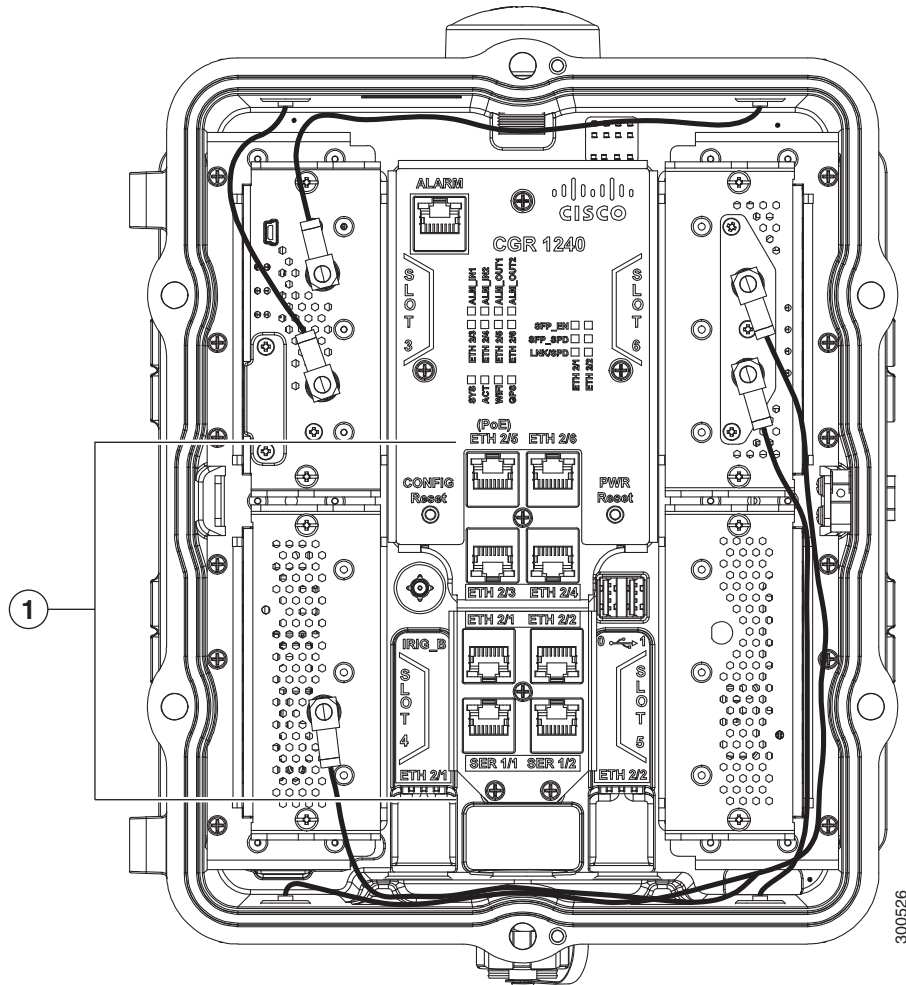

Connect to Power

Note About Power over Ethernet (PoE)

If the module is connected to a PoE port on the router, you do not have to follow the steps in this section because the module is powered over Ethernet cable that you connected by following the steps in [Connect to the Network, page 178](#).

Note About Module Power Connector

Depending on your module power cable, you might need to provide an adapter to connect the module to a 4-pin Micro-Fit 3.0 power connector (see [Non-Cisco Module Power Connector, page 198](#)).

To connect the module to power:

1. Verify that the module power cable is threaded through the router cable port, and that the cable port has cable glands or an O-ring installed.
2. Connect the power cable to the Micro-Fit 3.0 power connector. See in 2 in [Figure 98 on page 180](#) for connector location.

Figure 98 Cable Harness and Power Connector

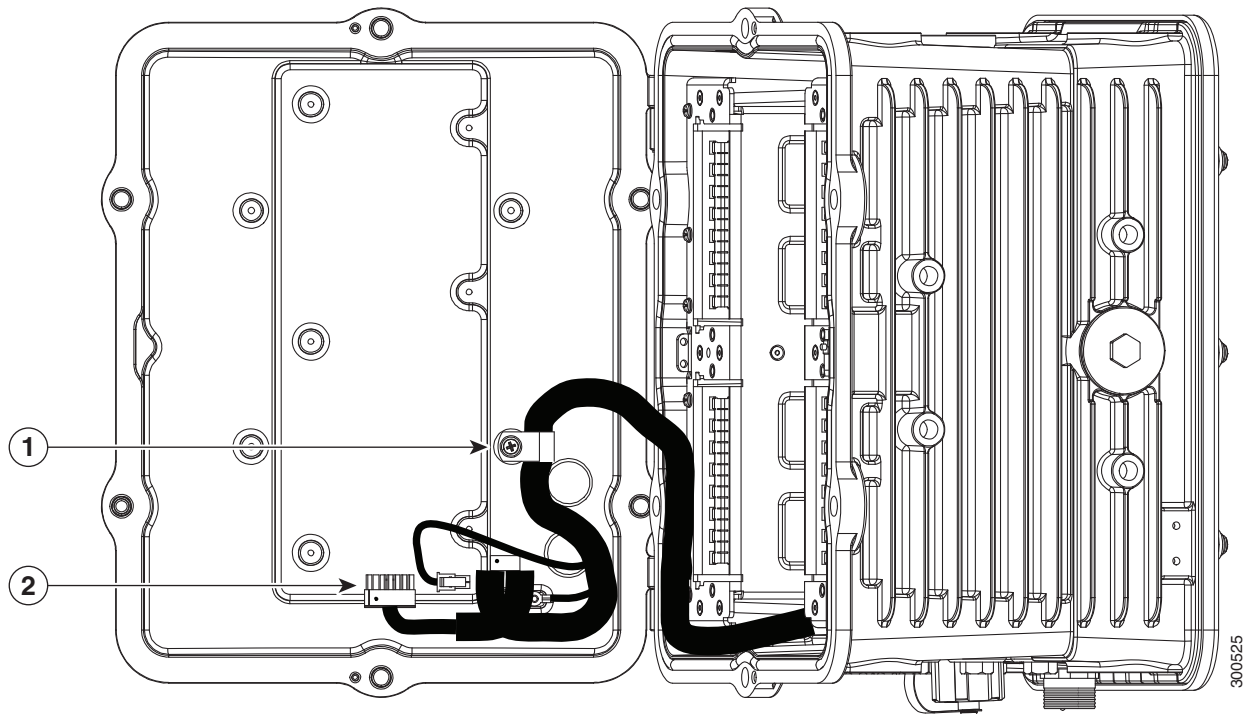

Related Information

This chapter describes installation procedures. For detailed, technical information about the router hardware, including connector and cable descriptions, specifications, and pinouts, see:

- [Router Hardware Description, page 9](#) describes all features of the router hardware, including the ports and cable glands.
- [Connector and Cable Specifications, page 195](#) includes the pinouts for the 12V power connector used to provide power to non-Cisco modules.



Router LED Locations and States

This section describes the Cisco 1240 Connected Grid Router (CGR 1240 or router) LEDs and how to determine the overall state of the system and verify the status of specific connections, ports, and system components.

In addition to viewing the LEDs on the router hardware, you can use the router command line interface as described in [Related Commands, page 186](#) to check the system status LED state from remote locations.

These topics are discussed:

- [LED Locations and State Descriptions, page 181](#)
- [Related Commands, page 186](#)

LED Locations and State Descriptions

SYS LED—System Status

View the system status LED to determine the overall operating and power status of the router.

A second, identical system status LED is located inside the router. See the [Alarm and Network Connection LEDs, page 182](#) for the location of the interior SYS LED.

Figure 99 System Status LED (SYS) – Router Bottom Exterior

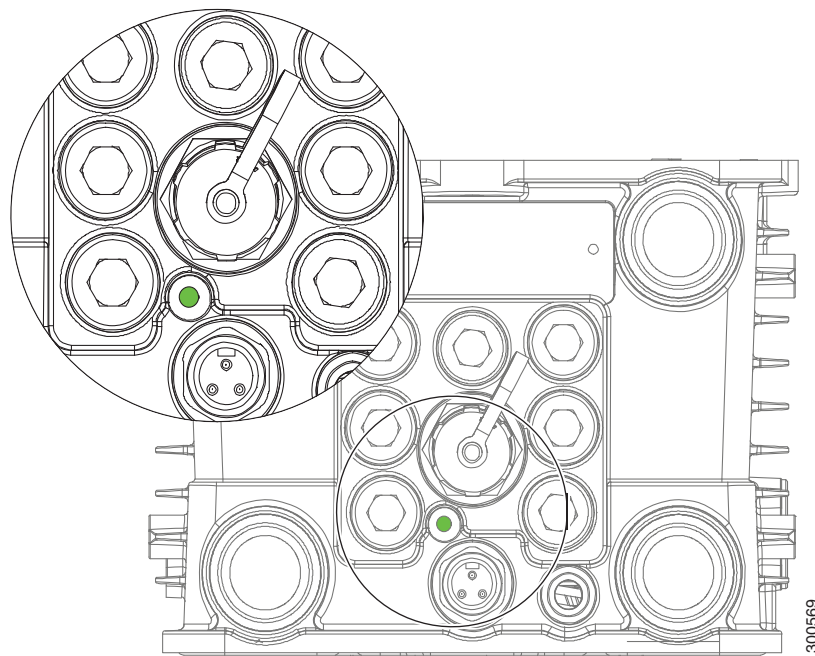

Table 32 SYS LED Status

Label Description	Color and State	Description
SYS System status	Green	Normal system operating status
	Green blinking	The system is starting up or power cycling, and loading system software, including BIOS and operating system
	Amber	System receiving power but there is an error condition
	Amber blinking	Interface is down and admin is up. To avoid, shutdown unused interfaces.
	Off	System not receiving power

Alarm and Network Connection LEDs

The router LEDs that indicate network activity and connection status, and the LEDs that indicate alarm states, are located inside the router. To see these LEDs, you must open the router chassis according to the instructions in [Opening and Closing the Router Chassis, page 75](#).

Figure 100 Network and Alarm LEDs – Router Front Interior

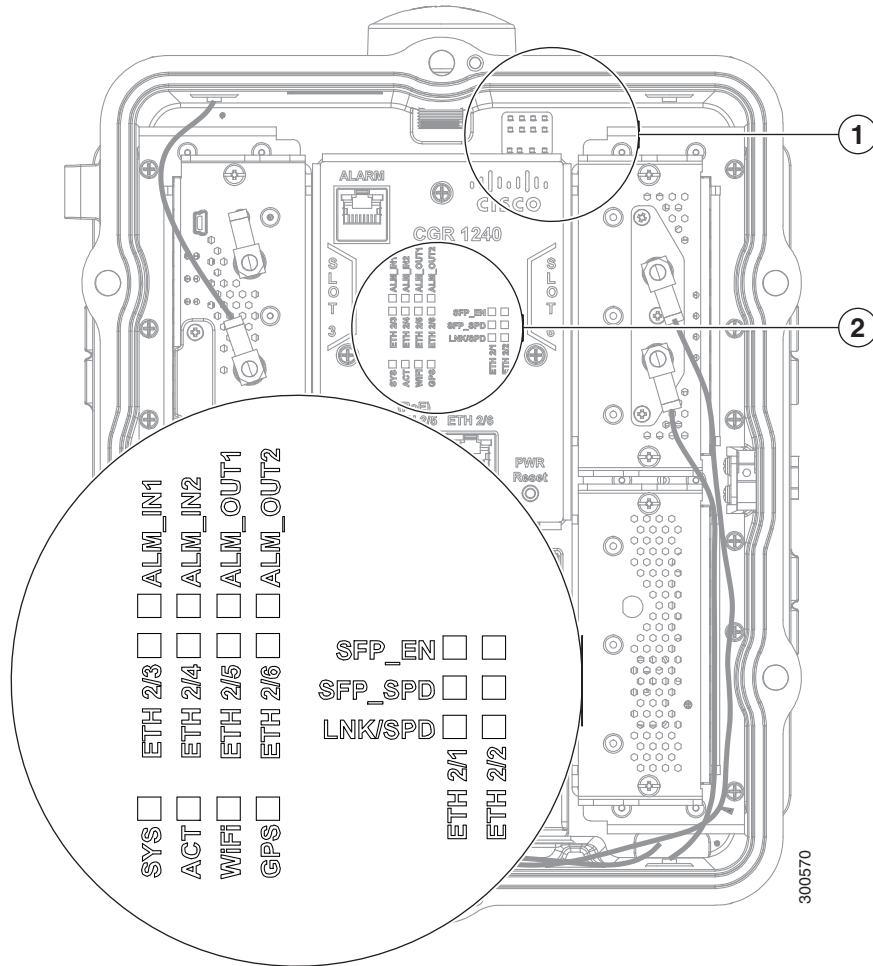

ALM LEDs—Alarm Status

Table 33 Alarm LEDs

LED Label	Color and State	Description
ALM_IN1 ALM_IN2	Off	No alarm condition is present on the port
ALM_OUT1 ALM_OUT2	Red solid	Alarm condition present on the port

ETH LEDs—Fast Ethernet Interface Status

Table 34 Fast Ethernet LEDs

LED Label	Color and State	Description
ETH 2/3	Off	No link established
ETH 2/4	Green solid	Ethernet link established
	Amber, 2 blinks/pause	100 MB/s link speed
ETH 2/5	Amber, 1 blink/pause	10 MB/s link speed
ETH 2/6		

SFP LEDs—Combo Port and SFP Port Status

The ETH 2/1 and ETH 2/2 interfaces are shared. Each interface (ETH 2/1 and ETH 2/2) supports either a fiber optic GE connection (using an SFP module) or a copper GE connection, but not both (see [Combo Ports, page 35](#)).

Table 35 Combo Port LEDs—SFP Module and Gigabit Ethernet Ports

LED Label	LED Label	Color and State	Description
ETH 2/1 ETH 2/2	SFP_EN —This LED is active only for fiber optic (SFP module) connections on the ETH 2/1 and ETH 2/2 ports.		
		Off	No SFP installed in the port
		Green solid	Supported SFP installed in the SFP port
		Green blinking	SFP module can be removed or replaced
		Amber solid	Unsupported SFP installed in the SFP port
	SFP_SPD —This LED is active only for fiber optic (SFP module) connections on the ETH 2/1 and ETH 2/2 ports.		
		Green, 3 blink/pause	1000 MB/s link speed
		Green, 2 blinks/pause	100 MB/s link speed
		Off	No SFP link established on the optical GE port
	LNK/SPD —This LED is active only for copper GE connections on the ETH 2/1 and ETH 2/2 ports.		
		Amber, 3 blinks/pause	1000 MB/s link speed
		Amber, 2 blinks/pause	100 MB/s link speed
		Amber, 1 blink/pause	10 MB/s link speed
		Green solid	Ethernet cable connected and link established
		Off	No link established

SYS and ACT LEDs—System Status

Table 36 System LED

LED Label	Color and State	Description
SYS	Note: This LED has the same functionality as the SYS LED on the router exterior, described in SYS LED—System Status, page 181 .	
	Green	Normal system operating status
	Green blinking	The system is starting up or power cycling, and loading system software, including BIOS and operating system
	Amber	System receiving power but there is an error condition
	Off	System not receiving power
ACT	Off	No system data packet activity
	Green	System data packet activity between the system and any data port
	Green blinking	System data packet activity between the system and any data port

WiFi LED—WiFi Link State

Table 37 WiFi LEDs

LED Label	Color and State	Description
WiFi	Green	WiFi link established
	Green blinking	WiFi link established and data transfer in progress
	Yellow	No WiFi link

GPS LED—GPS Link State

Table 38 GPS LED

LED Label	Color and State	Description
GPS	Green	Locked but not receiving data
	Green blinking	Locked and receiving data
	Yellow blinking	Acquiring satellite
	Yellow solid	No GPS link

Battery Backup Unit LED

The router supports up to three battery backup units (BBUs). When two or more BBUs are installed, they are connected to each other in a head-to-tail configuration in the router and the BBU LED are in the locations shown in [Figure 101 on page 185](#).

To see the LED for each BBU, open the router chassis as described in [Opening and Closing the Router Chassis, page 75](#).

Figure 101 Battery Backup LED Location

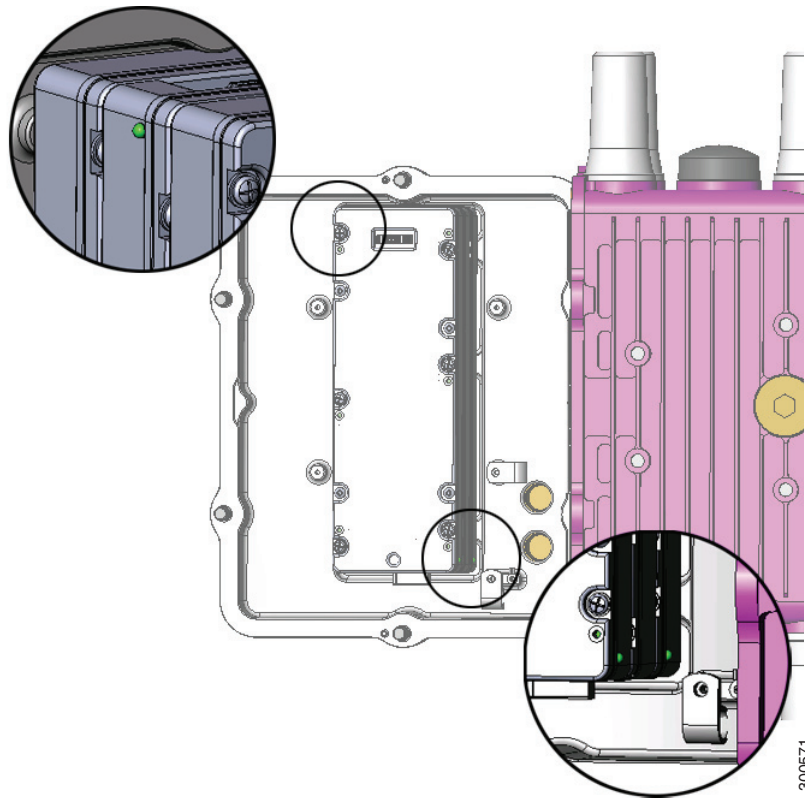

LED	Color and State	Description
BBU (no label)	Green solid	Idle state
	Green blinking	Charging
	Amber blinking	Discharging (providing power to the system)
	Amber slow blinking	Disabled with the system software
	Alternate Red/green blinking	Initializing
	Red blinking	Bootloader mode
	Red slow blinking	Test mode
	Red solid	BBU failure
	Off	Disconnected from router or completely discharged

SD Flash Memory Module LED – SD Card Status

To see the SD card and the SD LED, you must remove the exterior plug that covers the router SD card port, as shown in [Figure 102 on page 186](#).

Figure 102 SD Card (SD0)– Router Right Side Exterior

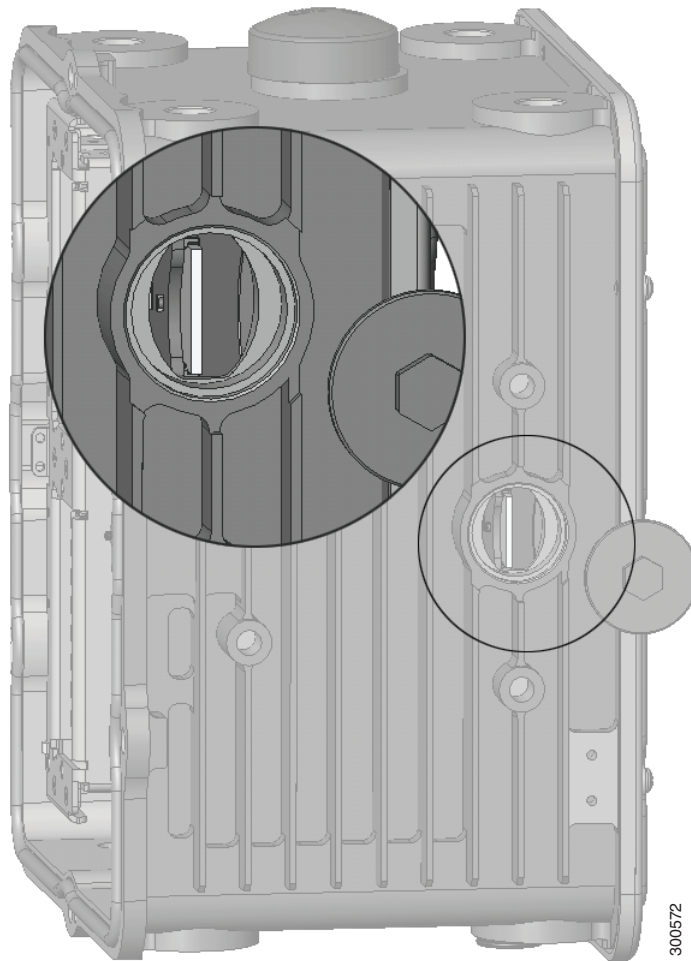

Label	Color and State	Description
SD0	Green	SD flash card installed and operating normally Note: If the SD Card is removed, the SD flash memory module LED remains green until the router is rebooted.
	Green blinking	SD flash card data transfer in process
	Amber	<ul style="list-style-type: none"> ■ Error when system accesses the SD flash card ■ Router cannot locate a system software image
	Amber blinking	Unsupported SD card installed in the slot

Related Commands

Commands related to displaying LED status information for the different operating systems (Cisco CG-OS and Cisco IOS) used on the CGR 1240 router are presented in this section.

An example of the usefulness of the command is that during normal operation, the router can be installed at the top of an outdoor pole or other inaccessible location, and you may not be able to view the SYS LED on the router hardware. In this case, you can view the status of the LED from a remote location using the router CLI.

The range of commands presented includes:

- [Displaying Router SYS LED Status Command, page 187](#)
- [Displaying Interface Status Command, page 188](#)

Displaying Router SYS LED Status Command

A show command can be used to display the SYS LED status in text format. There are two SYS LEDs on the CGR router: the first SYS LED is located on the router exterior (see [Figure 99 on page 181](#)) and the second is inside the router chassis (see [Figure 100 on page 182](#)). [Table 32 on page 182](#) describes the SYS LED status.

The operating system show commands are:

- [Cisco CG-OS show led Command, page 187](#)
- [Cisco IOS show platform led Command, page 187](#)

Cisco CG-OS show led Command

On a CGR 1240 router using the Cisco CG-OS operating system, use the **show led** command in any command mode to view the status of the router SYS LED.

This example shows the **show led** command output:

```
CGR1240> show led
System LED: green, solid

Summary of LED status provider:
Client      | State
-----
cellular 3/1 | Blinking

--- end of list ---
CGR-1040>
```

Cisco IOS show platform led Command

On a CGR 1240 router using the Cisco IOS operating system, use the **show platform led** command in global configuration mode to view the status of the router SYS LED.

```
CGR-1240# show platform led

LED STATUS:
=====

FE PORTS : FE2/3 FE2/4 FE2/5 FE2/6
LINK/ENABLE LED : OFF OFF OFF OFF
SPEED LED : unknown unknown unknown unknown

GE PORTS : GE2/1 GE2/2
LINK/ENABLE LED : GREEN GREEN
SPEED LED : 1Gbps 1Gbps

SFP PORTS : SFP1 SFP2
LINK/ENABLE LED : OFF OFF
SPEED LED : unknown unknown
=====
```

System LED: amber, blinking
Activity LED: blinking

Displaying Interface Status Command

The Cisco CG-OS and Cisco IOS operating systems use the show interface command to display status information about the router interfaces in privileged EXEC mode.

Sample output is presented in these sections:

- [Cisco CG-OS show interface Command, page 188](#)
- [Cisco IOS show interface Command, page 189](#)

Cisco CG-OS show interface Command

This example shows **show interface** command output for a CGR 1240 router running a Cisco CG-OS operating system:

```
CGR1240> show interface

Ethernet0 is up, line protocol is up
  Hardware is Lance, address is 0019.076c.1a78 (bia 0019.076c.1a78)
  Internet address is 172.28.231.193/23
  MTU 1500 bytes, BW 10000 Kbit, DLY 1000 usec, rely 255/255, load 1/255
  Encapsulation ARPA, loopback not set, keepalive set (10 sec)
  ARP type: ARPA, ARP Timeout 04:00:00
  Last input 00:00:00, output 00:00:00, output hang never
  Last clearing of "show interface" counters never
  Queueing strategy: fifo
  Output queue 0/40, 0 drops; input queue 5/75, 32 drops
  5 minute input rate 10000 bits/sec, 27 packets/sec
  5 minute output rate 10000 bits/sec, 26 packets/sec
    16076431 packets input, 1280716531 bytes, 27 no buffer
  Received 1809290 broadcasts, 0 runts, 0 giants
    1105 input errors, 0 CRC, 0 frame, 0 overrun, 1105 ignored, 0 abort
    0 input packets with dribble condition detected
    16196175 packets output, 1011044938 bytes, 0 underruns
    19 output errors, 184 collisions, 3 interface resets
    0 babbles, 0 late collision, 1474 deferred
    19 lost carrier, 0 no carrier
    0 output buffer failures, 0 output buffers swapped out
Serial0 is administratively down, line protocol is down
  Hardware is HD64570
  MTU 1500 bytes, BW 1544 Kbit, DLY 20000 usec, rely 255/255, load 1/255
  Encapsulation HDLC, loopback not set, keepalive set (10 sec)
  Last input never, output never, output hang never
  Last clearing of "show interface" counters never
  Input queue: 0/75/0 (size/max/drops); Total output drops: 0
  Queueing strategy: weighted fair
  Output queue: 0/64/0 (size/threshold/drops)
    Conversations 0/0 (active/max active)
    Reserved Conversations 0/0 (allocated/max allocated)
  5 minute input rate 0 bits/sec, 0 packets/sec
  5 minute output rate 0 bits/sec, 0 packets/sec
    0 packets input, 0 bytes, 0 no buffer
  Received 0 broadcasts, 0 runts, 0 giants
    0 input errors, 0 CRC, 0 frame, 0 overrun, 0 ignored, 0 abort
    0 packets output, 0 bytes, 0 underruns
    0 output errors, 0 collisions, 1 interface resets
    0 output buffer failures, 0 output buffers swapped out
    0 carrier transitions
  DCD=down DSR=down DTR=down RTS=down CTS=down
```

Cisco IOS show interface Command

This example shows **show interface** command output for a CGR 1240 router running a Cisco IOS operating system:

```
CGR1240> show interface

GigabitEthernet0/1 is up, line protocol is up
  Hardware is iGbE, address is 0022.bdec.f0f9 (bia 0022.bdec.f0f9)
  Internet address is 192.168.1.254/24
  MTU 1500 bytes, BW 1000000 Kbit/sec, DLY 10 usec,
    reliability 255/255, txload 1/255, rxload 1/255
  Encapsulation ARPA, loopback not set
  Keepalive set (10 sec)
  Auto Duplex, Auto Speed, media type is internal
  output flow-control is unsupported, input flow-control is unsupported
  ARP type: ARPA, ARP Timeout 04:00:00
  Last input 00:06:39, output 00:00:06, output hang never
  Last clearing of "show interface" counters never
  Input queue: 0/75/0/0 (size/max/drops/flushes); Total output drops: 0
  Queueing strategy: fifo
  Output queue: 0/40 (size/max)
  5 minute input rate 0 bits/sec, 0 packets/sec
  5 minute output rate 0 bits/sec, 0 packets/sec
    8579 packets input, 612922 bytes, 0 no buffer
    Received 994 broadcasts (0 IP multicasts)
    0 runts, 0 giants, 0 throttles
    0 input errors, 0 CRC, 0 frame, 0 overrun, 0 ignored
    0 watchdog, 497 multicast, 0 pause input
    58519 packets output, 6541254 bytes, 0 underruns
    0 output errors, 0 collisions, 0 interface resets
    0 unknown protocol drops
    0 babbles, 0 late collision, 0 deferred
    1 lost carrier, 0 no carrier, 0 pause output
    0 output buffer failures, 0 output buffers swapped out
Dot11Radio2/1 is administratively down, line protocol is down
  Hardware is 802.11N 2.4GHz Radio, address is 5cda.d4ad.092a (bia 5cda.d4ad.092a)
  MTU 1500 bytes, BW 72000 Kbit/sec, DLY 0 usec,
    reliability 0/255, txload 1/255, rxload 1/255
  Encapsulation ARPA, loopback not set
  Keepalive set (10 sec)
  ARP type: ARPA, ARP Timeout 04:00:00
  Last input never, output never, output hang never
  Last clearing of "show interface" counters never
  Input queue: 0/75/0/0 (size/max/drops/flushes); Total output drops: 0
  Queueing strategy: fifo
  Output queue: 0/30 (size/max)
  5 minute input rate 0 bits/sec, 0 packets/sec
  5 minute output rate 0 bits/sec, 0 packets/sec
    0 packets input, 0 bytes, 0 no buffer
    Received 0 broadcasts (0 IP multicasts)
    0 runts, 0 giants, 0 throttles
    0 input errors, 0 CRC, 0 frame, 0 overrun, 0 ignored
    0 input packets with dribble condition detected
    0 packets output, 0 bytes, 0 underruns
    0 output errors, 0 collisions, 0 interface resets
    0 unknown protocol drops
    0 babbles, 0 late collision, 0 deferred
    0 lost carrier, 0 no carrier
    0 output buffer failures, 0 output buffers swapped out
FastEthernet2/3 is down, line protocol is down
  Hardware is Fast Ethernet, address is 0022.bdec.f0f3 (bia 0022.bdec.f0f3)
  MTU 1500 bytes, BW 100000 Kbit/sec, DLY 100 usec,
    reliability 255/255, txload 1/255, rxload 1/255
```

```
Encapsulation ARPA, loopback not set
Keepalive set (10 sec)
Auto-duplex, Auto-speed
ARP type: ARPA, ARP Timeout 04:00:00
Last input never, output never, output hang never
Last clearing of "show interface" counters never
Input queue: 0/75/0/0 (size/max/drops/flushes); Total output drops: 0
Queueing strategy: fifo
Output queue: 0/40 (size/max)
5 minute input rate 0 bits/sec, 0 packets/sec
5 minute output rate 0 bits/sec, 0 packets/sec
  0 packets input, 0 bytes, 0 no buffer
  Received 0 broadcasts (0 multicasts)
  0 runts, 0 giants, 0 throttles
  0 input errors, 0 CRC, 0 frame, 0 overrun, 0 ignored
  0 watchdog, 0 multicast, 0 pause input
  0 input packets with dribble condition detected
  0 packets output, 0 bytes, 0 underruns
  0 output errors, 0 collisions, 2 interface resets
  0 unknown protocol drops
  0 babbles, 0 late collision, 0 deferred
  0 lost carrier, 0 no carrier, 0 pause output
  0 output buffer failures, 0 output buffers swapped out
FastEthernet2/4 is administratively down, line protocol is down
Hardware is Fast Ethernet, address is 0022.bdec.f0f4 (bia 0022.bdec.f0f4)
MTU 1500 bytes, BW 100000 Kbit/sec, DLY 100 usec,
  reliability 255/255, txload 1/255, rxload 1/255
Encapsulation ARPA, loopback not set
Keepalive set (10 sec)
Auto-duplex, Auto-speed
ARP type: ARPA, ARP Timeout 04:00:00
Last input never, output never, output hang never
Last clearing of "show interface" counters never
Input queue: 0/75/0/0 (size/max/drops/flushes); Total output drops: 0
Queueing strategy: fifo
Output queue: 0/40 (size/max)
5 minute input rate 0 bits/sec, 0 packets/sec
5 minute output rate 0 bits/sec, 0 packets/sec
  0 packets input, 0 bytes, 0 no buffer
  Received 0 broadcasts (0 multicasts)
  0 runts, 0 giants, 0 throttles
  0 input errors, 0 CRC, 0 frame, 0 overrun, 0 ignored
  0 watchdog, 0 multicast, 0 pause input
  0 input packets with dribble condition detected
  0 packets output, 0 bytes, 0 underruns
  0 output errors, 0 collisions, 0 interface resets
  0 unknown protocol drops
  0 babbles, 0 late collision, 0 deferred
  47966 lost carrier, 0 no carrier, 0 pause output
  0 output buffer failures, 0 output buffers swapped out
```



Starting a Router Terminal Session

This section describes how to start a terminal session with the Cisco 1240 Connected Grid Router (CGR 1240 or router) using the console port. Start a terminal session with the router when you are at the router installation location and want to administer the router with a direct connection using the command-line interface (CLI) software.

These topics are discussed:

- [About the Console Port, page 191](#)
- [Connecting to the Console Port with Microsoft Windows, page 192](#)
- [Connecting to the Console Port with Mac OS X, page 192](#)
- [Connecting to the Console Port with Linux, page 192](#)

Before You Begin

Before you start a terminal session with the router, you must connect a PC or PC terminal to the router console port by following the instructions in [Connecting the Console Port, page 100](#).

About the Console Port

Caution: The console port does not support cable glands. When a cable is connected to this port, the router interior is exposed to environmental elements, which can damage the port and the router interior. This port should be exposed only during terminal sessions, when a cable is connected to the port. This port should never be left unattended when in use.

The console port is an asynchronous serial port that allows you to connect to the device for initial configuration through a standard RS-232 port with an RJ-45 connector. Any device connected to this port must be capable of asynchronous transmission.

Console Port Settings

Configure the following parameters for the console port:

Parameter	Console Port Setting	Description
Baud	9600	Specifies the transmission speed for the connection.
Data bits	8	Specifies the number of bits in an 8-bit byte that is used for data.
Parity	None	Specifies the odd or even parity for error detection.
Stop bits	1	Specifies the stop bits for an asynchronous line.

Using the Ctrl-C Command

The router console port is located on the router exterior and is accessible by removing the seal over the console port (see [Console Port, page 24](#)).

On many Cisco routers, you can enter **Ctrl-C** to interrupt the router startup process and then delete or change the admin password, or view or delete the router configuration.

To prevent unauthorized access to the router configurations and passwords, the Ctrl-C command is disabled on the Cisco CGR 1240 Router while it is booting up and loading the system software.

Connecting to the Console Port with Microsoft Windows

To connect to the router console port using Microsoft Windows:

1. Start a terminal emulator application, such as Windows HyperTerminal (included with some versions of Windows OS) or PuTTY.
2. Configure the terminal emulation software with the parameters described in [About the Console Port, page 191](#).
3. Connect to the router.

Connecting to the Console Port with Mac OS X

To connect a Mac OS X system USB port to the console using the built-in OS X Terminal utility:

1. Use the Finder to go to **Applications > Utilities > Terminal**.
2. Connect the OS X USB port to the router.
3. Enter the following commands to find the OS X USB port number:

```
macbook:user$ cd /dev
macbook:user$ ls -ltr /dev/*usb*
crw-rw-rw- 1 root  wheel      9,  66 Apr  1 16:46 tty.usbmodem1a21
DT-macbook:dev user$
```

4. Connect to the USB port with the following command followed by the router USB port speed:

```
macbook:user$ screen /dev/tty.usbmodem1a21 9600
```

To Disconnect the OS X USB Console from the Terminal Window

Enter **Ctrl+A** followed by **Ctrl+**

Connecting to the Console Port with Linux

To connect a Linux system USB port to the console using the built-in Linux Terminal utility:

1. Open the Linux Terminal window.
2. Connect the Linux USB port to the router.
3. Enter the following commands to find the Linux USB port number:

```
root@usb-suse# cd /dev
root@usb-suse /dev# ls -ltr *ACM*
crw-r--r-- 1 root  root      188,   0 Jan 14 18:02 ttyACM0
root@usb-suse /dev#
```

4. Connect to the USB port with the following command followed by the router USB port speed:

```
root@usb-suse /dev# screen /dev/ttyACM0 9600
```

To Disconnect the Linux USB Console from the Terminal Window

Enter **Ctrl+A** followed by **:**, and then type **quit**.





Connector and Cable Specifications

This section includes specifications for the Cisco 1240 Connected Grid Router (CGR 1240 or router) connectors, adapters, and compatible cables.

These topics are discussed:

- [Connector Specifications, page 195](#)
- [Cable and Adapter Specifications, page 200](#)

Connector Specifications

- [Alarm Ports, page 195](#)
- [Console Port, page 196](#)
- [Serial Port, page 197](#)
- [AC Power Supply Connector, page 198](#)
- [Non-Cisco Module Power Connector, page 198](#)

Alarm Ports

For detailed information about the alarm ports, see [Router Hardware Description, page 9](#).

Table 39 Alarm Port Specification

Pin	Signal Description
1	Alarm1_IN
2	Alarm_IN Common
3	Alarm2_IN
4	Alarm1_OUT NC
5	Alarm1_OUT Common
6	Alarm1_OUT NO
7	Alarm2_OUT NC
8	Alarm2_OUT Common
9	Alarm2_OUT NO
10	NC

NOTE: It is recommended that the cable plugged into the alarm port tie all three common signals together. For example, in [Table 39 on page 195](#), tie RJ-50 pins 2, 5, and 8 to each other.

Console Port

For detailed information about the console port, see [Router Hardware Description, page 9](#).

Table 40 Console/Auxiliary Port Specification

Pin	Signal Name	Signal Description
1	RTS	Output
2	DTR	Output
3	TXD	Output
4	GND	-
5	GND	-
6	RXD	Input
7	DSR/DCD	Input
8	CTS	Input

Copper Interface–Combination Port (SFP and GE Ethernet)

For detailed information about the combination ports, see [Router Hardware Description, page 9](#).

Table 41 Combination Port Specification –Copper Interface

Pin	1000Base-T	100Base-TX/10Base-T
1	TX A+	TX DATA+
2	TX A-	TX DATA-
3	RX B+	RX DATA+
4	TX C+	N/C
5	TX C-	N/C
6	RX B-	RX DATA-
7	RX D+	N/C
8	RX D-	N/C

SFP Interface–Combination Port (SFP and GE Ethernet)

For detailed information about the combination ports, see [Router Hardware Description, page 9](#).

Table 42 SFP Port Specification

Pin	Signal Name	Input/Output	Signal Description
1	VeeT	-	GND
2	TxFault	Output	Optical output failure
3	TxDisable	Input	Optical output disable
4	MOD-DEF(2)	Bidir	Bidirectional. Connects to I2C data
5	MOD-DEF(1)	Input	Connects to I2C Clock
6	MOD-DEF(0)	Output	Grounded in SFP, indicates SFP is present
7	Rate Select ¹	-	-
8	LOS	Output	Loss of Receive optical signal indicator

Table 42 SFP Port Specification (continued)

Pin	Signal Name	Input/Output	Signal Description
9	VeeR	-	GND
10	VeeR	-	GND
11	VeeR	-	GND
12	RD-	Output	Differential electrical output to PHY
13	RD+	Output	Differential electrical output to PHY
14	VeeR	-	Gnd
15	VccR	-	3.3V
16	VccT	-	3.3V
17	VeeT	-	GND
18	TD+	Input	Differential input from PHY
19	TD-	Input	Differential input from PHY
20	VeeT	-	GND

¹ Rate Select is an optional SFP input that controls receiver bandwidth when used with Fiber Channel applications. This pin is not connected.

Serial Port

For detailed information about the combination ports, see [Router Hardware Description, page 9](#).

Table 43 Serial Port Specification

RS-232 ¹			RS-485 Full Duplex		RS-485 Half Duplex	
Pin	Signal Description (Abbreviation)	DCE	Signal	Dir	Signal	Dir
1	DCE ready, ring indicator (DSR/RI)	Output	TX+	-	TX/RX+	-
2	Received line signal detector (DCD)	Output	TX-	-	TX/RX-	-
3	DTE ready (DTR)	Input	Not used	-	Not used	-
4	Signal ground (COM)	-	COM	-	COM	-
5	Received data (RxD)	Output	Not used	Output	Not used	Bidirectional
6	Transmitted data (TxD)	Input	RX+	Input	Not used	-
7	Clear to send (CTS)	Output	Not used	Output	Not used	Bidirectional
8	Request to send (RTS)	Input	RX-	Input	Not used	-

¹ The RS232 pinouts use the EIA-561 standard.

AC Power Supply Connector

For detailed information about the hardware described in this section, see [Router Hardware Description, page 9](#).

Table 44 AC Power Supply Connector Specification

Pin	Signal Name	Signal Description
1	L	AC line
2	N	AC neutral
3	Chassis	Chassis ground

Non-Cisco Module Power Connector

This section provides the following information for the power connector for installing external, non-Cisco modules on the router:

- Power wiring specifications in the [Table 45 on page 198](#).

Note: The cable that you provide to connect the module to the 12V power connector must be wired so that Pin 3 (cable presence) and Pin 4 (ground) are connected to each other. If they are not connected, the module will not detect power from the router.

- Power connector parts, and compatible parts in [Table 46 on page 199](#).

For more information about non-Cisco modules, see [Installing External Non-Cisco Modules, page 173](#).

Table 45 Non-Cisco Module Power Connector Specifications

Pin	Signal Name	Signal Description
1	12V	12V power from router
2	GND	System ground
3	CBL_PRSENT_L	Cable presence detect
4	GND	System ground

Table 46 Molex Part Specifications and Mating Connector Requirements

Part	Molex Part Number	Description
Included Module Power Connector Parts		
Micro-Fit 3.0™ Receptacle Housing	43025-0400	Power connector housing installed on the router power harness for connection to an external, non-Cisco module. <ul style="list-style-type: none">■ 0.118 inch (3 mm) pitch■ Dual row■ 4 circuits,■ Halogen free
Micro-Fit 3.0™ Crimp Terminal	43030-0003	Contacts installed on the router power harness for connection to an external, non-Cisco module. <ul style="list-style-type: none">■ Female■ Select gold (Au) plated phosphor bronze contact■ 20-24 AWG■ Reel
Cisco-Recommended Mating Parts		
Pitch Micro-Fit 3.0™ Plug Housing	43020-0401	Cisco recommends this or comparable part as mating connector. Halogen free is a not a requirement for the mating connector. <ul style="list-style-type: none">■ 0.118 inch (3 mm) pitch■ Dual row■ Without panel mount ears■ Halogen free■ 4 circuits
Micro-Fit 3.0™ Crimp Terminal	43031-0003	Cisco recommends this or a comparable part as the crimp terminal. <ul style="list-style-type: none">■ Male■ Select gold (Au) plated tin/brass alloy contact■ 20-24 AWG■ Reel

Cable and Adapter Specifications

SFP Cable

For detailed information about the SFP ports, see [Router Hardware Description, page 9](#).

Table 47 SFP Port Cabling Specification

SFP Module	Wavelength (nm)	Cable Type	Core size/ Cladding Size (micron)	Modal Bandwidth (MHz/km)	Cable Distance
1000BASE-SX	850	MMF	62.5/125	160	722 feet (220 m)
			62.5/125	200	902 feet (275 m)
			50/125	400	1640 feet (500 m)
			50/125	500	1804 feet (550 m) 3281 ft (1000 m)
1000BASE-LX/LH	1310	MMF ¹	62.5/125	500	1804 feet (550 m)
			50/125	400	1804 feet (550 m)
			50/125	500	1804 feet (550 m)
		SMF	G.6522	–	32,808 feet (10,000 km)
1000BASE-EX	1310	SMF	–	–	131,234 feet (40,000 km)
1000BASE-ZX	1550	SMF	G.652 ²	–	43.4 to 62 miles (70 to 100 km) ²
1000BASE-BX-U	1310	SMF	–	–	32,808 ft (10,000 m)
1000BASE-BX-D	1490	SMF	–	–	32,808 ft (10,000 m)

¹ A mode-conditioning patch cord is required. Using an ordinary patch cord with MMF or 1000BASE-LX/LH SFP modules and a short link distance can cause transceiver saturation and an elevated bit error rate (BER). When using the LX/LH SFP module with 62.5-micron diameter MMF, you must also install a mode-conditioning patch cord between the SFP module and the MMF cable on both the sending and receiving ends of the link. The mode-conditioning patch cord is required for link distances greater than 984 feet (300 m).

² 1000BASE-ZX SFP modules can send data up to 62 miles (100 km) by using dispersion-shifted SMF or low-attenuation SMF; the distance depends on the fiber quality, the number of splices, and the connectors.