



# Configuring SONET

---

This module describes how to configure Synchronous Optical Network (SONET). SONET defines optical signals and a synchronous frame structure for multiplexed digital traffic. SONET equipment is generally used in North America.

The transport network using SONET provides much more powerful networking capabilities than existing asynchronous systems.

- [Overview of SONET, on page 1](#)
- [Restrictions for SONET, on page 2](#)
- [SONET Switching , on page 3](#)
- [SONET Hierarchy, on page 4](#)
- [STS-1 and STS-3 Frames, on page 5](#)
- [SONET Line and Section Configuration Parameters, on page 6](#)
- [BERT, on page 7](#)
- [BERT Error Injection, on page 9](#)
- [Concatenated SONET Frames, on page 12](#)
- [SONET Path Level Configuration Parameters, on page 13](#)
- [Channelized SONET Frames, on page 13](#)
- [SONET T1 Configuration Parameters, on page 13](#)
- [SONET T3 Configuration Parameters, on page 14](#)
- [SONET VT Configuration Parameters, on page 14](#)
- [Automatic Protection Switching , on page 15](#)
- [How to Configure SONET, on page 20](#)
- [Configuring Port Rate and Verifying Pluggables, on page 61](#)
- [Loopback Remote on T1 and T3 Interfaces, on page 63](#)
- [Associated Commands, on page 65](#)

## Overview of SONET

SONET is a set of standards that define the rates and formats for optical networks specified in GR-253-CORE. SONET is based on a structure that has a basic frame format and speed. The frame format used by SONET is the Synchronous Transport Signal (STS), with STS-1 as the base-level signal at 51.84 Mbps. An STS-1 frame can be carried in an OC-1 signal.

SONET has a hierarchy of signaling speeds.

## Restrictions for SONET

- With Synchronous Transport Signal (STS) Circuit Emulation over Packet (CEP) or STS concatenated CEP mode, if you receive a B3 error, then the Remote Error Indication (REI) won't be generated. Request for Comments (RFC) reference—RFC 4842.
- Prior to Cisco IOS XE Cupertino 17.9.1 release, in V-15 or VC1x mode without or with CEM (SAToP/CEP/CESoP), overhead TX\_V5 default value is 1.
- From Cisco IOS XE Cupertino 17.9.1 release onwards, when CEM (SAToP (framed or Unframed) and CESoP) is configured for VT-15 or VC1x mode, overhead TX\_V5 default value is 2. If CEM isn't configured or VT CEP is configured, then the default value for V5 Overhead is 1. V5 byte value can be modified according to need using configuration `vt <> vt <> overhead v5 <>`.
- Rate combinations are one port of OC-48 or four ports of OC-12 or OC-3.
- Only 16 BERT Patterns can be configured at a time.
- VT1.5 VT can't be configured if VT1.5 T1/DS1 is configured with the same KLM value.
- PMON fields aren't supported for VT1.5 VT and DS3 or T3.
- PMON Far-end parameters aren't supported.

### Restrictions on Bandwidth

- Total available bandwidth is 10G.

The following configuration is blocked and an error message is displayed after the maximum bandwidth is utilized:

```
rate OC3| OC12| OC48| OC192
```

The bandwidth of adjacent ports shouldn't exceed OC-48.

The following table shows the bandwidth used by different rates:

**Table 1: Bandwidth Used by Different Rates**

| Rate  | Bandwidth   |
|-------|-------------|
| OC-3  | 155.52 Mbps |
| OC-12 | 622.08 Mbps |
| OC-48 | 2.4 Gbps    |

### Restrictions for Clock Source Configuration

- Only four ports can be configured in SONET line for clock source configuration per chassis.
- You should configure the clock source line and network-clock sync together to receive the clock from a remote port that is connected to the SONET port.

### Restrictions for BER Threshold

- The BER threshold value 10e-9 is not supported for the following line, path, and VT BER CLIs on the following interface modules:
  - Line BER CLIs **threshold b2-tca**, **threshold sd-ber** and **threshold sf-ber**.
  - PATH BER CLIs **threshold b3-ber\_sd**, **threshold b3-ber\_sf**, and **threshold b3-tca**.
  - VT BER CLIs **threshold bip2-sd**, **threshold bip2-sf**, and **threshold bip2-tca**.
  - **Not Supported Interface Modules for the Above BER CLIs**

## SONET Switching

SONET Switching is achieved on optical interface modules by circuit emulation. Circuit Emulation (CEM) is a way to carry TDM circuits over packet switched network. CEM embeds TDM bits into packets, encapsulates them into an appropriate header and then sends that through Packet Switched Network (PSN). The receiver side of CEM restores the TDM bit stream from packets.

### Modes of CEM:

- **Structure Agnostic TDM over Packet (SAToP)** (RFC 4553) – Structure-Agnostic TDM over Packet (SAToP) mode is used to encapsulate T1 or T3 unstructured (unchannelized) services over packet switched networks. In SAToP mode, the bytes are sent out as they arrive on the TDM line. Bytes do not have to be aligned with any framing.

In this mode, the interface is considered as a continuous framed bit stream. The packetization of the stream is done according to IETF RFC 4553. All signaling is carried transparently as a part of a bit stream.

- **Circuit Emulation Service over Packet (CEP)** (RFC 4842) - CEP mode is used to encapsulate SONET payload envelopes (SPEs) like VT1.5 or VT2 or STS-1 or STS-Nc over packet switched networks. In this mode, the bytes from the corresponding SPE are sent out as they arrive on the TDM line. The interface is considered as a continuous framed bit stream. The packetization of the stream is done according to IETF RFC 4842.

**Table 2: Modes of CEM**

| Mode    | CEM   | Ports                      |
|---------|-------|----------------------------|
| STS-48C | CEP   | OC-48, OC-192              |
| STS-12C | CEP   | OC-12, OC-48, OC-192       |
| STS-3C  | CEP   | OC-3, OC-12, OC-48, OC-192 |
| STS-1   | CEP   | OC-3, OC-12, OC-48, OC-192 |
| DS3     | SAToP | OC-3, OC-12, OC-48, OC-192 |
| DS3-T1  | SAToP | OC-3, OC-12, OC-48, OC-192 |
| VT 1.5  | CEP   | OC-3, OC-12, OC-48, OC-192 |
| VT DS1  | SAToP | OC-3, OC-12, OC-48, OC-192 |

# SONET Hierarchy

Figure 1: A SONET Link

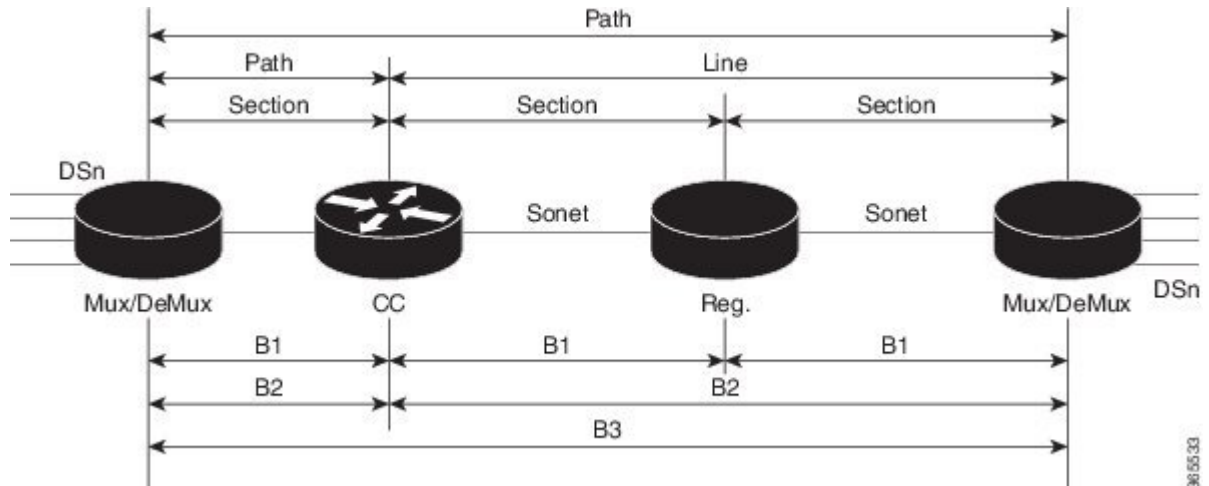

Each level of the SONET hierarchy terminates its corresponding fields in the SONET payload, as follows:

## Section

A section is a single fiber run that can be terminated by a network element (Line or Path) or an optical regenerator.

The main function of the section layer is to properly format the SONET frames, and to convert the electrical signals to optical signals. Section Terminating Equipment (STE) can originate, access, modify, or terminate the section header overhead.

## Line

Line-Terminating Equipment (LTE) originates or terminates one or more sections of a line signal. The LTE does the synchronization and multiplexing of information on SONET frames. Multiple lower-level SONET signals can be mixed together to form higher-level SONET signals. An Add/Drop Multiplexer (ADM) is an example of LTE.

## Path

Path-Terminating Equipment (PTE) interfaces non-SONET equipment to the SONET network. At this layer, the payload is mapped and demapped into the SONET frame. For example, an STS PTE can assemble 25 1.544 Mbps DS1 signals and insert path overhead to form an STS-1 signal.

This layer is concerned with end-to-end transport of data.

# STS-1 and STS-3 Frames

A standard STS-1 frame is nine rows by 90 bytes. The first three bytes of each row represent the Section and Line overhead. These overhead bits comprise framing bits and pointers to different parts of the SONET frame.

Figure 2: STS-1 Frame Structure

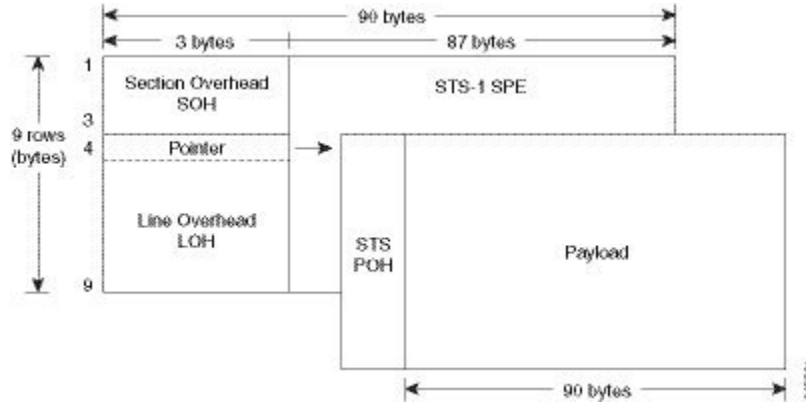

There is one column of bytes in the payload that represents the STS path overhead. This column frequently "floats" throughout the frame. Its location in the frame is determined by a pointer in the Section and Line overhead.

The combination of the Section and Line overhead comprises the transport overhead, and the remainder is the SPE.

Figure 3: STS-1 SONET Overhead

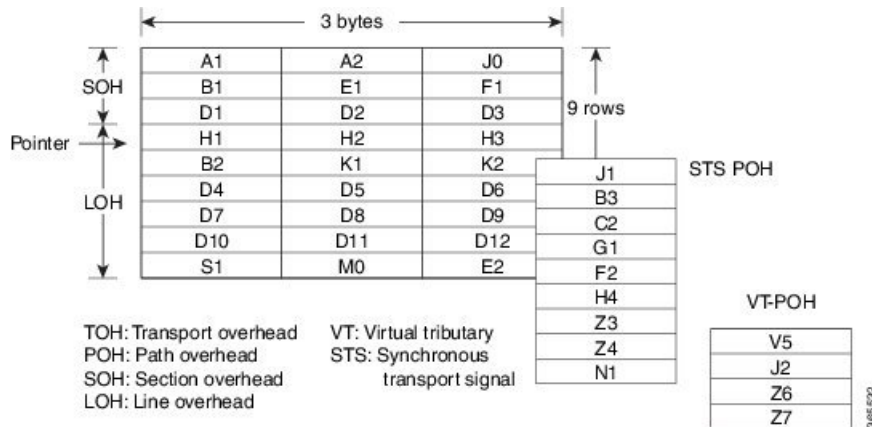

For STS-1, a single SONET frame is transmitted in 125 microseconds, or 8000 frames per second.  $8000 \text{ fps} * 810 \text{ B/frame} = 51.84 \text{ Mbs}$ , of which the payload is roughly 49.5 Mbs, enough to encapsulate 28 DS-1s, a full DS-3, or 21 CEPT-1s.

An STS-3 frame is nine rows by 270 bytes. The first nine columns contain the transport overhead section, and the rest is SPE. For both STS-3 and STS-3c, the transport overhead (Line and Section) is the same.

For an STS-3 frame, the SPE contains three separate payloads and three separate path overhead fields. In essence, it is the SPE of three separate STS-1s packed together, one after another.

For more information on Section Overhead, Line Overhead, and Path Overhead, refer the following:

- <http://www.cisco.com/c/en/us/support/docs/optical/synchronous-digital-hierarchy-sdh/5462-sdh-overview.html>
- <http://www.cisco.com/c/en/us/support/docs/optical/synchronous-optical-network-sonet/13567-sonet-tech-tips.html>
- <http://www.cisco.com/c/en/us/tech/optical/synchronous-optical-network-sonet/tsd-technology-support-troubleshooting-technotes-list.html>

## SONET Line and Section Configuration Parameters

The following parameters affect SONET configuration at the line and section levels:

- **Overhead** — Sets the SONET overhead bytes in the frame header to a specific standards requirement, or to ensure interoperability with equipment from another vendors.
  - **J0** — Sets the J0 or C1 byte value in the SONET section overhead.



---

**Note** 1 byte, 16 bytes, and 64 bytes are the supported values for J0.

---

- **S1S0** — Sets the SS bits value of the H1 byte in the SONET line overhead.
- **Loopback** — Sets a loopback to test the SONET port.
- **AIS-Shut** — Configures the SONET port to send the Alarm Indication Signal (AIS) at shutdown.
- **Shut** — Disables an interface.
- **Alarm Reporting** — Enables reporting for all or selected alarms.
  - **lias** — Enables line alarm indication signal.
  - **lrldi** — Enables line remote defect indication signal.
  - **pais** — Enables path alarm indication signal.
  - **plop** — Enables loss of pointer failure signal for a path.
  - **pplm** — Enables path payload mismatch indication.
  - **prdi** — Enables path remote defect indication signal.
  - **sd-ber** — Sets Signal Degrade BER threshold.
- **Clock** — Specifies the clock source, where:
  - **line** — The link uses the recovered clock from the line.
  - **internal** — The link uses the internal clock source. This is the default setting.

# BERT

Bit-Error Rate Testing (BERT) is used for analyzing quality and for problem resolution of digital transmission equipment. BERT tests the quality of an interface by directly comparing a pseudorandom or repetitive test pattern with an identical locally generated test pattern.

The BERT operation is data-intensive. Regular data cannot flow on the path while the test is in progress. The path is reported to be in alarm state when BERT is in progress and restored to a normal state after BERT has been terminated.

BERT is supported in the following two directions:

- Line - Supports BERT in TDM direction.
- System - Supports BERT in PSN direction.

## BERT Restrictions

- BERT is not supported on the following modes:
  - T3—Framing M-13, non-channelized
  - E3—Framing G832, channelized
- When the BERT is initiated with pattern 0s and 1s from the local end and the loopback local is applied from the far end, then the BERT syncing does not happen. Since the BERT process is asserted as LOS alarms for all 0s and AIS alarms for all 1s BERT patterns. Whereas the BERT syncing behaves properly when the BERT is initiated from both the local and the far end.

For all 1s on T3 or E3, the BERT behaviour is not asserted as AIS and the BERT syncing happens as usual.

- In the unframed mode, BERT sync is not stable and may generate alarms until Cisco IOS XE Fuji 16.9.4.



---

**Note** Framing type should be similar in all routers end to end.

---

- System BERT is not supported for any pattern in framed SATOP for releases earlier to Cisco IOS XE 17.13.1.
- System BERT is not configurable, without cem-group configuration.
- The default BERT pattern supported is PRBS. The QRSS pattern is supported only on T1 or E1 level and the STS-1E path level for pattern 2^20-O151.

### BERT Restrictions for Cisco IOS XE Bengaluru 17.4.1 release

- When the BERT is initiated from the local end and the loopback local is applied from the far end, then BERT syncing does not happen. Since the BERT process is asserted as LOS alarms for all 0s and AIS alarms for all 1s BERT patterns. Whereas the BERT syncing behaves properly when the BERT is initiated from both the local and the far end.

## BERT Patterns on 1-Port OC-48 or 4-Port OC-12/OC-3 CEM Interface Module

Table 3: Feature History

| Feature Name                            | Release Information           | Description  |
|---|-------------------------------|--|
| Support for all 0s and 1s BERT Patterns | Cisco IOS XE Bengaluru 17.4.1 | Support for all 0s and 1s BERT patterns for SONET and SDH. |

The BERT patterns on the 1-Port OC-48 or 4-Port OC-12/OC-3 interface module are:

Table 4: BERT Pattern Descriptions

| Keyword                            | Description  |
|------------------------------------|--|
| <b>All 1s</b><br><a href="#">1</a> | Pseudo-random binary test pattern consisting of all 1's that is used to test alternating line volt and repeaters.  |
| <b>All 0s</b>                      | Pseudo-random binary test pattern consisting of all 0's that is used for test line coding.   |
| <b>2^15-1 O.151</b>                | Pseudo-random O.151 test pattern consisting of a maximum of 14 consecutive zeros and 15 consecutive ones. The length of this pattern is 32,768 bits.     |
| <b>2^20-O.151</b>                  | Pseudo-random O.151 test pattern consisting of a maximum of 19 consecutive zeros and 20 consecutive ones. The length of this pattern is 1,048,575 bits.  |
| <b>2^20-O.153</b>                  | Pseudo-random O.153 test pattern consisting of a maximum of 19 consecutive zeros and 20 consecutive ones. The length of this pattern is 1,048,575 bits.  |
| <b>2^23-1 O.151</b>                | Pseudo-random O.151 test pattern consisting of a maximum of 22 consecutive zeros and 23 consecutive ones. The length of this pattern is 8,388,607 bits.  |
| <b>2^9</b><br><a href="#">2</a>    | Pseudo-random binary test pattern consisting of a maximum of eight consecutive zeros and nine consecutive ones. The length of this pattern is 511 bits.  |
| <b>2^11</b><br><a href="#">3</a>   | Pseudo-random binary test pattern consisting of a maximum of ten consecutive zeros and eleven consecutive ones. The length of this pattern is 2048 bits. |

<sup>1</sup> All 1s are supported only on SONET CT3, SDH AU-3 - CT3/CE3 - T1/E1, and SDH AU-3 - VC3. Starting with Cisco IOS XE Bengaluru 17.4.1, All 1s are supported on all modes.

<sup>2</sup> Starting with Cisco IOS XE Bengaluru 17.4.1, 2^9 mode is supported.

2^9 is not supported on the following modes:

- SONET—Unframed, STS-3c, STS-12c, and STS-48c.



- SDH AU-4—VC4, TUG-3-VC3, TUG-3-E3, TUG-3-T3, and TUG-3 - VC1x.
  - SDH AU-3—VC3, VC4-4c, VC4-16c, and VC1x.
- <sup>3</sup> Starting with Cisco IOS XE Bengaluru 17.4.1, 2^11 mode is supported.
- 2^11 is not supported on the following modes:
- SONET—Unframed, STS-3c, STS-12c, and STS-48c.
  - SDH AU-4—VC4 and TUG-3-VC3.
  - SDH AU-3—VC3, VC4-4c, and VC4-16c.



**Note** If All 1's BERT pattern is tested on the system side, then ensure that you need to start all 1's pattern from both sides of the end points.

Configuring BERT on one side and loopback on other side of the end points is not supported. The router treats all 1's pattern as AIS alarm and BERT will not come in sync with the other side configuration of the end point.

## BERT Error Injection

*Table 5: Feature History*

| Feature Name         | Release Information           | Description  |
|----------------------|-------------------------------|--|
| BERT Error Injection | Cisco IOS XE Bengaluru 17.4.1 | BERT Error injection enables you to inject errors into the BERT stream on SONET and SDH controllers. You can introduce BERT errors in a range of 1 to 255. |

This feature enables you to inject a fixed number of BERT errors when a BERT pattern is running and check the same number of BERT errors to be received at the remote end. Starting with Cisco IOS XE Bengaluru 17.4.1 release, you can configure BERT error injection using the **bert errors count of errors** command and before configuring the errors, you must use the **bert pattern** command.

BERT Error Injection is supported on T1 and T3 for SONET and SDH controllers.

BERT Error Injection is supported in the following modes:

*Table 6: Supported Modes for BERT Error Injection*

| Controller | Mode  |
|------------|---|
| SONET      | <ul style="list-style-type: none"> <li>• STS-1 T3</li> <li>• STS-1 CT3</li> <li>• VT-15 – T1</li> <li>• VT-15 – VT</li> </ul> |

| Controller | Mode  |
|------------|---|
| SDH        | <ul style="list-style-type: none"> <li>• AU-3 - CE3</li> <li>• AU3 - CT3</li> <li>• AU3 - E3</li> <li>• AU3 - T3</li> <li>• AU3 - VC1X</li> <li>• AU4 - VC3</li> <li>• AU4 -Tug-3 E3</li> <li>• AU4 -Tug-3 VC1x</li> <li>• AU4 -Tug-3 T3</li> </ul> |

## Prerequisites of BERT Error Injection

- Ensure that you have set up BERT engine before injecting BERT Errors.

## Restrictions of BERT Error Injection

- The BERT Error Injection once configured cannot be removed.
- BERT Error Injection is not supported on the SONET unframed mode.
- A maximum of 16 BERT engines are supported per LOTR card.
- You can configure a maximum of 255 BERT Error counts on the IM.
- BERT Error Injection is **not** supported on the following modes:
  - SONET: Unframed, STS-3C, STS-12C, STS-48C
  - SDH: VC4-4C, VC4-16C, AU3-V3, AU4-VC4

## Configuring BERT Error Injection for SONET

### Configuring BERT Error Injection - STS-1 T3 Mode

Ensure that you configure the STS-1 and T3 mode followed by BERT Pattern on the SONET STS-1 T3 interface.

To configure BERT Error Injection for the STS-1 mode on the T3 interface, enter the following commands:

```

config terminal
Enter configuration commands, one per line. End with CNTL/Z.
PE1(config)#controller sonet 0/4/0
PE1(config-controller)#sts-1 1
PE1(config-ctrlr-sts1)#t3 bert errors 255
Router#(config-ctrlr-sts1)#end

```

### Configuring BERT Error Injection - STS-1 CT3 Mode

Ensure that you configure the STS-1 and CT3 mode followed by BERT Pattern on the SONET STS-1 CT3 interface

To configure BERT Error Injection for the STS-1 CT3 mode, enter the following commands:

```

Router#(config)#controller sonet 0/4/0
Router#(config-controller)#sts-1 1
Router#(config-ctrlr-sts1)#t1 1 bert errors 255
Router#(config-ctrlr-sts1)#end

```

### Configuring BERT Error Injection - VT-15 – T1 Mode

Ensure that you configure the STS-1 VT-15 and T1 modes followed by BERT Pattern on the SONET VT-15 T1 interface.

To configure BERT Error Injection for the STS-1 VT-15 and T1 modes, enter the following commands:

```

Enter configuration commands, one per line. End with CNTL/Z.
Router# (config)#controller sonet 0/4/0
Router# (config-controller)#sts-1 1
Router# (config-ctrlr-sts1)#vtg 1 t1 1 bert errors 255
Router# (config-ctrlr-sts1)#end

```

### Configuring BERT Error Injection - VT-15 – VT Mode

: Ensure that you configure the STS-1 VT-15 and VT modes followed by BERT Pattern on the SONET VT-15 VT modes.

To configure BERT Error Injection for the STS-1 VT-15 and VT modes, enter the following commands

```

config terminal
Enter configuration commands, one per line. End with CNTL/Z.
Router#(config)#controller sonet 0/4/0
Router#(config-controller)#sts-1 1
Router#(config-ctrlr-sts1)#vtg 1 vt 1 bert errors 255
Router#(config-ctrlr-sts1)#end

```

## Verifying BERT Error Injection for SONET

### Verifying BERT Error Injection – STS-1 T3 Mode

To verify BERT Error Injection for the STS-1 mode on the T3 interface, use the **show-controller SONET | sec BERT** command;

```

Router# show controller sonet 0/4/0 | sec BERT
BERT test result (running)
Test Pattern : All 0's, Status : Sync, Sync Detected : 1
DSX3 BERT direction : Line
Interval : 60 minute(s), Time Remain : 00:59:00
Bit Errors (since BERT started): 255 bits,
Bits Received (since BERT started): 2697 Mbits
Bit Errors (since last sync): 255 bits

```

```
Bits Received (since last sync): 2697 Mbits
Direction      : Line
```

### Verifying BERT Error Injection – STS-1 CT3 Mode

To verify BERT Error Injection for the STS-1 mode and CT3 mode, use the **show-controller SONET | sec BERT** command:

```
Router#
show controller sonet 0/4/0 | sec BERT
BERT test result (running)
Test Pattern : All 0's, Status : Sync, Sync Detected : 1
Interval : 60 minute(s), Time Remain : 00:59:01
Bit Errors (since BERT started): 255 bits,
Bits Received (since BERT started): 89 Mbits
Bit Errors (since last sync): 255 bits
Bits Received (since last sync): 89 Mbits
Direction : Line
```

### Verifying BERT Error Injection – STS-1 VT-15 and T1 Modes

To verify BERT Error Injection for the STS-1 VT-15 and T1 modes, use the **show-controller SONET | sec BERT** command:

```
Router#
show controller sonet 0/4/0 | sec BERT
BERT running on timeslots 1,2,3,4,5,6,7,8,9,10,11,12,13,14,15,16,17,18,19,20,21,22,23,24,
BERT test result (running)
Test Pattern : All 0's, Status : Sync, Sync Detected : 1
Interval : 60 minute(s), Time Remain : 00:58:59
Bit Errors (since BERT started): 255 bits,
Bits Received (since BERT started): 92 Mbits
Bit Errors (since last sync): 255 bits
Bits Received (since last sync): 92 Mbits
Direction : Line
```

### Verifying BERT Error Injection – STS-1 VT-15 and VT Modes

To verify BERT Error Injection for the STS-1 VT-15 and VT modes, use the **show-controller SONET | sec BERT** command:

```
Router#
show controller sonet 0/4/0 | sec BERT
BERT test result (running)
Test Pattern : All 0's, Status : Sync, Sync Detected : 1
Interval : 60 minute(s), Time Remain : 00:59:00
Bit Errors (since BERT started): 255 bits,
Bits Received (since BERT started): 94 Mbits
Bit Errors (since last sync): 255 bits
Bits Received (since last sync): 94 Mbits
Direction : Line
```

## Concatenated SONET Frames

Twenty-eight VTs make up one STS-1. Three STS-1s made up an STS-3 and so on. Any one byte within the STS frame has a direct relationship to a base VT that helps to make up the STS.

A lower-case "c" in the STS rate stands for "concatenated", and indicates that the interface hardware is not channelized. Examples of concatenated interfaces are STS-3c and STS-12c.

The STS-1s may be concatenated into sets of 3 or 12 or 24 or 48 or 192 to form STS-3c, STS-12c, and so on. The STS-1s may be combined only at specific STS-n boundaries within an OC port.

## SONET Path Level Configuration Parameters

The following parameters affect SONET configuration at the path level:

- **BERT** — Starts the BERT test.
- **Clock** — Specifies the clock source for a path.
- **Exit** — Exits from SONET path configuration mode.
- **Loopback** — Sets the entire path in the loopback mode.
- **Mode** — Specifies the path operation mode.
- **No** — Negates a command or sets its defaults.
- **Overhead** — Configures SONET path overhead flags.
- **Shutdown** — Disables the SONET path.
- **Threshold** — Sets the path BER threshold values.
- **vtg** — Sets the VT-15 configuration.

## Channelized SONET Frames

A channelized SONET interface is a composite of lower-speed STS streams. However, a channelized SONET interface maintains the streams as independent frames with unique payload pointers. The frames are simply multiplexed before transmission to increase the carrying capacity of the physical fiber. This process is similar to multiplexing 24 digital signal level 0 channels into a DS1 or multiplexing 28 DS1 streams into a DS3.

## SONET T1 Configuration Parameters

The following parameters affect SONET T1 configuration:

- **BERT** — Starts the BERT test.
- **Clock** — Specifies the clock source for T1 interface.
- **Description** — Specifies the description of the controller.
- **Framing** — Specifies the type of a framing on T1 interface.
- **Loopback** — Sets the T1 interface in the loopback mode.
- **Shutdown** — Disables the T1 interface.

## SONET T3 Configuration Parameters

The following parameters affect SONET T3 configuration:

- **Clock** — Specifies the clock source for T3 link.
- **Description** — Specifies the description of the controller.
- **Framing** — Specifies the type of a framing on T3 interface.
- **Loopback** — Sets the T3 link in the loopback mode.
- **Shutdown** — Disables the T3 interface.

## SONET VT Configuration Parameters

The following parameters affect SONET VT configuration:

- **BERT** — Starts the BERT test.
  - **CEM Group** — Specifies the time slots for CEM group mapping.
- **Clock** — Specifies the clock source for VT.
- **Description** — Specifies the description of the controller.
- **Loopback** — Sets the VT in the loopback mode.
- **Overhead** — Configures VT line path overhead flags.
- **Shutdown** — Disables the VT interface.
- **Threshold** — Configures the VT threshold values.

# Automatic Protection Switching

Table 7: Feature History

| Feature Name                                       | Release Information           | Feature Description  |
|--|-------------------------------|--|
| IMA3G 1+1 OC3/12 Single Card APS Support           | Cisco IOS XE Amsterdam 17.3.1 | Automatic protection switching (APS) is a protection mechanism for SONET networks that enables SONET connections to switch to another SONET circuit when a circuit failure occurs. This protection schemes allows a pair of SONET lines or paths to be configured for line or path redundancy. In the event of a fiber cut, the active line or path switches automatically to the standby line or path. In the 1+1 architecture, there is one working interface (circuit) and one protection interface, and the same payload from the transmitting end is sent to both the receiving ends. The receiving end decides which interface to use. |
| CEM and IP IW Feature Parity for Interface Modules | Cisco IOS XE Bengaluru 17.4.1 | Support for APS and non-APS on SDH and SONET for iMSG IPv6 interworking on Interface Module.   |

Automatic protection switching (APS) is a protection mechanism for SONET networks that enables SONET connections to switch to another SONET circuit when a circuit failure occurs. A protection interface serves as the backup interface for the working interface. When the working interface fails, the protection interface quickly assumes its traffic load.

The SONET protection schemes partially comply with Telcordia—GR-253-CORE standard. It allows Optical Interface Module to work seamlessly as SONET Add or Drop Multiplexers (ADM). The implementation of the above protection schemes allows a pair of SONET lines or paths to be configured for line or path redundancy. In the event of a fiber cut, the active line or path switches automatically to the standby line or path in up to 60 milliseconds (2/5/10 millisecond for holdover and 50 millisecond switchovers).

Optical Interface Module supports the following SONET protection switching schemes:

- Linear Bidirectional 1+1 APS
- Linear Unidirectional 1+1 APS
- UPSR Path Protection at STS Level
- UPSR Path Protection at VT Level

## 1+1 APS

In the 1+1 architecture, there is one working interface (circuit) and one protection interface, and the same payload from the transmitting end is sent to both the receiving ends. The receiving end decides which interface to use. The line overhead (LOH) bytes (K1 and K2) in the SONET frame indicate both status and action.

The protection interfaces need to be configured with an IP address of the chassis that has the working interface, using APS commands. The APS Protect Group Protocol, which runs on top of UDP, provides communication between the process controlling the working interface and the process controlling the protection interface. Using this protocol, interfaces can be switched because of a chassis failure, degradation or loss of channel signal, or manual intervention. In bidirectional mode, the receive and transmit channels are switched as a pair.

Two SONET connections are required to support APS.

The following option is available for linear bidirectional 1+1 APS:

- Revertive option — For any failure on working line, the software switches to protection line and when the working line recovers, it waits based on the revertive timer and reverts back to working line as active link.
- Non-revertive option — When the signal fails, the software switches to the protection line and does not automatically revert back to the working line. This is the default option.

The following features are supported on 1+1 APS:

- SONET PW (SAToP or CEP)
- SONET local connect

## Benefits of APS

The following lists the benefits of APS:

- APS performs switchovers with minimal loss of data and time-consuming reroutes are avoided.
- There is no visibility that a failure has occurred beyond the network element in which it is residing; other nodes are not affected by the failure.
- Implementation of APS guards a network against complex restarts and resynchronizations since failures are isolated to a local device.
- With APS, the effect of a failure is greatly minimized and a fast switchover guarantees minimal effect on the network.

## APS 1+1 for SONET Layer 1 traffic

SONET linear APS 1+1 provides protection against both fiber cuts and front card or back card failures. APS 1+1 requires a redundant protection line for every working line. The traffic is simultaneously carried by the working and the protection lines. Hence, the receiver that terminates the APS 1+1 should select the traffic from one of the lines and continue to forward the traffic. APS 1+1 provides protection in unidirectional and bi-directional modes:

- **Uni-directional Protection:** The receiving end can switch from working to protection line without any coordination at the transmit end since both lines transmit the same information.
- **Bi-directional Protection:** The receiving end switches from working to protection line by coordinating at the transmit end.



### Scenario for Bidirectional APS 1+1

In the above figure, two are connected to provide APS 1+1 bi-directional protection. The highlighted one is the working line and the other is the protection line. The traffic is transmitted on both working and protection lines and received only on one line.

In a scenario where you encounter a fiber cut,

1. There is a cable cut in the working line. So, the receives a Loss of Signal (LOS) on working line.
2. starts generating K2 byte and sends it to the over the protection line.
3. receives the K2 byte and reacts on the receiving K2 byte.
4. starts sending K1 byte to the on the protection line.
5. starts sending K2 byte to on the protection line.
6. receives the K1/K2 byte and starts receiving the data from protection line. The protection line now acts as the active line.
7. sends K2 byte over the new active line to . receives this signal and starts accepting the data from this new active line.

### Scenario for Unidirectional APS 1+1

In the above figure, two are connected to provide APS 1+1 unidirectional protection. The figure shows a working line and a protection line. The traffic is transmitted on both working and protection line and received only on one line.

In a scenario where you encounter a fiber cut,

1. receives a LOS on RX working line.
2. detects LOS and starts receiving the data from the protection line. The protection line now becomes the active line.
3. receives the K2 byte and knows about switching event on device 2.

### Restrictions for APS

- APS group number of 255 and UPSR group ID of 1 can't be configured on the same router.
- For the releases earlier to Cisco IOS XE Cupertino 17.9.1, when there's a Line Remote Defect Indicator (LRDI) or Line Alarm Indication Signal (LAIS) alarm detected on the protect port, then the received K2 byte stays zero.  
For the releases later than Cisco IOS XE Cupertino 17.9.1, when there's an LRDI alarm on the protect channel, the received K2 reflects the LRDI alarm. Whereas for the LAIS alarm on the protect channel, due to all 1s in the SONET or SDH frame rx K1 or K2 becomes invalid, and the router displays the last received best value.
- The **aps exercise** command is not supported with interface modules.
- The APS switch commands are autocleared on reload and controller-shut operations.
- When APS is configured as the revertive mode, then **aps revert** must be enabled from both the ends.

- During *Wait-to-Restore (working)*, when you configure **no aps revert**, then it takes into effect only after the current wait to restore operation completes.
- On the RSP3 module, it takes a long time (for example, more than half an hour) to copy scale configuration (8064 VT CEP) from boot flash to the running configuration. As a workaround, you can copy the individual configuration one after the other from the CLI.
- You can perform a force switchover to overcome the following limitations:
  - An interface module OIR, either through physical or software causes the APS switchover time to be higher (500-600ms).
  - Shut or no shut of the port may lead to higher APS switchover time.
  - Removal of the active working or protect interface may lead to higher APS switchover time.

## UPSR Path Protection

**Table 8: Feature History**

| Feature Name                                       | Release Information           | Feature Description                        |
|--|-------------------------------|--|
| CEM and IP IW Feature Parity for Interface Modules | Cisco IOS XE Bengaluru 17.4.1 | Support for UPSR IPv6 on Interface Module. |

A Unidirectional Path Switching Ring (UPSR) is a unidirectional network with two rings, one ring used as the working ring and the other as the protection ring. The same signal flows through both rings, one clockwise and the other counterclockwise. It is called UPSR because monitoring is done at the path layer. A node receives two copies of the electrical signals at the path layer, compares them, and chooses the one with the better quality. If part of a ring between two ADMs fails, the other ring still can guarantee the continuation of data flow. UPSR, like the one-plus-one scheme, has fast failure recovery.

Once a signal fail condition or a signal degrade condition is detected, the hardware initiates an interrupt to software that switches from the working path to the protection path. Nonrevertive options are valid for UPSR path protection.



**Note** 1X OC-192 and 8X OC-48 interface modules only supports the nonrevertive option. The nonrevertive option is the default mode.



**Note** When an active link of UPSR and APS is configured on the same interface module and the interface module reloads, the convergence number for UPSR circuits to switch to backup is high ranging 100–200 ms. When each circuit is configured separately, the convergence time is always under 50 ms.

The maximum scale supported on UPSR at system level is 1000 circuits.

The UPSR path protection supports the following feature:

- SONET local connect and cross connect are supported at VT-15 CEP, STS-1c, STS-3c, STS-12c, and STS-48c levels. UPSR is also supported on TDM endpoints that are mapped to a pseudowire. T1 SAToP,

T3 SAToP, and CT3 are supported on an UPSR ring only with local connect mode. Cross connect of T1, T3, and CT3 circuits to UPSR are not supported until Cisco IOS XE Fuji 16.8.x.

Starting with Cisco IOS XE Fuji 16.9.x, the cross connect of T1, T3, and CT3 circuits to UPSR is supported. For xconnect with the CT3 mode, the CEM protection group interface only supports the VT-15 mode. For cross-connect configuration, see *Configuring UPSR*.

### Restrictions for iMSG UPSR Path Protection

- UPSR Dual Ring Interconnect (DRI) is not supported.
- UPSR Dual Node Interconnect (DNI) is not supported.
- T1 or E1 and T3 or E3 configurations are not supported, and only the OCx-related configuration is supported.
- HDLC UPSR supports 510 PPP or HDLC pseudowire per group for an interface module and 1020 PPP or HDLC pseudowire for a router.
- APS group number of 255 and UPSR group ID of 1 cannot be configured on the same router.

### Configuring iMSG UPSR

To configure protection group for iMSG UPSR, enter the following commands:

```
enable
configure terminal
protection-group 401 type STS48c
controller protection-group 401
type STS48c
channel-group 0
end
```

### Configuring UPSR

#### Protection Group Configuration

```
enable
configure terminal
protection-group 401 type STS48c
controller protection-group 401
type STS48c
cem-group 19001 cep
end
```

#### Cross-connect Configuration with the CT3 mode

For cross connect with the CT3 mode, the CEM protection group interface supports only the VT-15 mode.

```
protection-group 2 type vt1.5
controller protection-group 2
type vt1.5
cem-group 16002 unframed

controller sonet 0/4/0
sts-1 1
mode vt-15
vtg 1 t1 2 protection-group 2 working
```

```

controller sonet 0/5/0
sts-1 1
mode vt-15
vtg 1 t1 2 protection-group 2 protect

```

### Configuring UPSR Work and Protection Path Configuration

#### UPSR Work Path Configuration:

```

enable
configure terminal
controller MediaType 0/3/6
mode sonet
controller sonet 0/3/6
rate oc48
sts-1 1 - 48 mode sts-48c
protection-group 401 working
end

```

#### UPSR Protect Path Configuration:

```

enable
configure terminal
controller MediaType 0/12/6
mode sonet
controller sonet 0/12/6
rate oc48
sts-1 1 - 48 mode sts-48c
protection-group 401 protect
end

```

### Verifying UPSR Configuration

Use the **show protection-group** command to verify UPSR configuration:

```

show protection-group
PGN   Type      Working I/f          Protect I/f          Active Status
-----
401   STS48C   SONET0/3/6.1-48     SONET0/12/6.1-48     W           A
-----
Status legend:D=Deleted FO=Force SF=SignalFailure SD=SignalDegrade
               FL=Fail M=Manual L=Lockout C=Clear A=Auto
(W)=working, (P)=protect

```

## How to Configure SONET

This section describes how to configure SONET.

Each SFP port (0-7) can be configured as OC-3, OC-12, OC-48, or Gigabit Ethernet. SFP+ port (8) can be configured as OC-192 or 10 Gigabit Ethernet.

## Prerequisites for Configuring SONET

You must select the MediaType controller to configure and enter the controller configuration mode.

You must configure the controller as a SONET port.

## Configuring MediaType Controller

To configure MediaType Controller, use the following commands:

```
enable
configure terminal
controller MediaType 0/0/16
mode sonet
end
```

## Configuring SONET Ports

To configure SONET ports, use the following commands:

```
enable
configure terminal
controller MediaType 0/0/16
mode sonet
controller sonet 0/0/16
rate OC12
end
```

The above example shows how to configure SONET ports in OC-12 mode.

## Managing and Monitoring SONET Line

This section describes how to manage and monitor SONET.

### Configuring Line and Section Overhead

To configure line and section overhead, use the following commands:

```
enable
configure terminal
controller MediaType 0/0/16
mode sonet
controller sonet 0/0/16
overhead s1s0 2
overhead j0 tx length 1-byte
end
```



---

**Note** To restore the system to its default condition, use the **no** form of the command.

---

### Configuring Line Loopback

To configure loopback, use the following commands:

```
enable
configure terminal
controller sonet 0/0/16
loopback local
end
```



---

**Note** To restore the system to its default condition, use the **no** form of the command.

---

## Configuring AIS Shut

To configure AIS-Shut, use the following commands:

```
enable
configure terminal
controller sonet 0/0/16
ais-shut
end
```



---

**Note** The **no ais-shut** command will not send AIS.

---

## Configuring Shut

To configure Shut, use the following commands:

```
enable
configure terminal
controller sonet 0/0/16
shutdown
end
```



---

**Note** Use the **no shutdown** command to disable the interface.

---

## Configuring Alarm Reporting

To configure alarm reporting, use the following commands:

```
enable
configure terminal
controller sonet 0/0/16
alarm-report b2-tcs
end
```



---

**Note** To restore the system to its default condition, use the **no** form of the command.

---

## Configuring Clock

To configure clock, use the following commands:

```
enable
configure terminal
controller MediaType 0/0/16
mode sonet
controller sonet 0/0/16
```

```
clock source line
end
```



---

**Note** The default mode is internal.

---



---

**Note** To restore the system to its default condition, use the **no** form of the command.

---

### Configuring Network-Clock SONET

To configure network-clock SONET, use the following commands:

```
enable
configure terminal
network-clock input-source 1 controller sonet 0/0/16
end
```

## Configuring STS-1 Modes

To configure STS-1 modes, use the following commands:

```
enable
configure terminal
controller sonet 0/0/16
sts-1 1
mode vt-15
end
```



---

**Note** There is no default mode. The following modes are supported:

- mode vt-15
  - mode ct3
  - mode t3
  - mode unframed
- 



---

**Note** To restore the system to its default condition, use the **no** form of the command.

---

### Configuring DS1/T1 CT3 mode of STS-1

To configure DS1/T1 CT3 mode of STS-1, you can configure the T1 link using the following steps:

```
enable
configure terminal
controller sonet 0/0/16
sts-1 1
mode ct3
t1 1 clock source internal
```

```
t1 1 framing unframed
end
```



---

**Note** To restore the system to its default condition, use the **no** form of the command.

---

### Configuring STS-Nc - Contiguous Concatenation

To configure STS-Nc - contiguous concatenation, use the following commands:

```
enable
configure terminal
controller sonet 0/0/16
sts-1 1-3 mode sts-3c
end
```



---

**Note** To restore the system to its default condition, use the **no** form of the command.

---



---

**Note** To configure STS-3c or STS-12c, use the numbers as multiples for 3 or 12, respectively.

---

### Configuring APS for SAToP

This section describes the configuration of APS for SAToP.

#### Configuring Bi-directional ACR (SONET Framing)

To configure bi-directional ACR (SONET Framing), use the following commands:

```
enable
configure terminal
controller sonet 0/0/16
clock source internal
aps group acr 1
aps working 1
exit
controller sonet 0/0/17
aps group acr 1
aps protect 1 10.7.7.7
end
```



---

**Note** To restore the system to its default condition, use the **no** form of the command.

---

#### Configuring Unidirectional APS

To configure unidirectional ACR (SONET Framing), use the following commands:

```
enable
configure terminal
controller sonet 0/0/16
clock source internal
```



```

aps group acr 1
aps working 1
aps unidirectional
exit
controller sonet 0/0/17
aps group acr 1
aps protect 1 10.7.7.7
aps revert 3
aps adm
end

```



---

**Note** To restore the system to its default condition, use the **no** form of the command.

---



---

**Note** Ensure that you use same interface modules for both work and protect links.

---

### Verifying ACR Configurations

This section includes show commands for ACR: The following example shows the ACR groups that have been configured or deleted:

```

Router# show acr group

ACR Group Working I/f Protect I/f Currently Active Status
-----
1 SONET 0/0/16 SONET 0/0/16 SONET 0/0/16

```

The following example shows the configured working and protect CEM interfaces under the ACR controller:

```

Router# show acr group 1 detail cem
ACR Group      Working I/f      Protect I/f      Currently Active      Status
-----
CE1            CEM 0/0/16      CEM 0/0/17      CEM 0/0/16

CEM CKT Details
Cktid  State on Working  State on Protect
1      Enable Success    Enable Success

```

The following example shows the configuration under the ACR controller:

```

Router#show running-config | sec ACR
controller SONET-ACR 1
framing sonet
!
sts-1 1
  mode vt-15
  vtg 1 vt 1 cem-group 1 cep
!
sts-1 2
!
sts-1 3
interface CEM-ACR1
no ip address
cem 1
!

```

The following example shows the loopback IP address for the router:

```
Router# show ip interface brief | i Loopback

Loopback0 172.16.0.1 YES NVRAM up up
```

The following example shows the CEM-ACR circuit status:

```
Router# show cem circuit

CEM Int. ID Ctrlr Admin Circuit AC
-----
CEM-ACR1 1 UP UP Active UP
CEM-ACR1 2 UP UP Active UP
CEM-ACR1 3 UP UP Active UP
CEM-ACR1 4 UP UP Active UP
CEM-ACR1 5 UP UP Active UP
CEM-ACR1 6 UP UP Active UP
CEM-ACR1 7 UP UP Active UP
CEM-ACR1 8 UP UP Active UP
```

The following example shows the CEM-ACR circuit details for CEM group 0 under the CEM-ACR interface:

```
Router# #show cem circuit interface cem-acr 1 1

CEM-ACR1, ID: 0, Line: UP, Admin: UP, Ckt: ACTIVE
Path Mode : VT15, STS: 1, VTG: 1, T1: 1, CEM Mode: T1-SAToP
Controller state: up, T1/E1 state: up
Idle Pattern: 0xFF, Idle CAS: 0x8
Dejitter: 6 (In use: 0)
Payload Size: 192
Framing: Unframed
CEM Defects Set
None

Signalling: No CAS
RTP: Configured, RTP-HDR Compression: Disabled

Ingress Pkts:      8186065          Dropped:          0
Egress Pkts:      8186065          Dropped:          0

CEM Counter Details
Input Errors:      0                Output Errors:     0
Pkts Missing:     0                Pkts Reordered:   0
Misorder Drops:   0                JitterBuf Underrun: 0
Error Sec:        0                Severly Errored Sec: 0
Unavailable Sec:  0                Failure Counts:    0
Pkts Malformed:  0                JitterBuf Overrun: 0
Generated Lbits:  0                Received Lbits:    0
Generated Rbits:  0                Received Rbits:    0
```

The following example shows the MPLS L2 transport vc details for the specified vc. In this case it is the vc with vc-id = 1001:

```
Router# sh mpls l2 vc 1 det
Local interface: CE1 up, line protocol up, SATOP T1 1 up
  Destination address: 10.2.2.2, VC ID: 1, VC status: up
  Output interface: Te 0/0/16, imposed label stack {100}
  Preferred path: not configured
  Default path: active
  Next hop: 192.168.1.2
Create time: 02:48:15, last status change time: 02:47:26
Last label FSM state change time: 02:47:26
Signaling protocol: LDP, peer 10.2.2.2:0 up
Targeted Hello: 10.1.1.1(LDP Id) -> 10.2.2.2, LDP is UP
```

```

Graceful restart: not configured and not enabled
Non stop routing: configured and enabled
Status TLV support (local/remote) : enabled/supported
  LDP route watch                  : enabled
  Label/status state machine       : established, LruRru
  Last local dataplane status rcvd: No fault
  Last BFD dataplane status rcvd: Not sent
  Last BFD peer monitor status rcvd: No fault
  Last local AC circuit status rcvd: No fault
  Last local AC circuit status sent: No fault
  Last local PW i/f circ status rcvd: No fault
  Last local LDP TLV status sent: No status
  Last remote LDP TLV status rcvd: No fault
  Last remote LDP ADJ status rcvd: No fault
MPLS VC labels: local 16, remote 100
Group ID: local 38, remote 36
MTU: local 0, remote 0
Remote interface description:
Sequencing: receive disabled, send disabled
Control Word: On (configured: autosense)
SSO Descriptor: 10.2.2.2/1, local label: 16
Dataplane:
  SSM segment/switch IDs: 274581/4096 (used), PWID: 1
VC statistics:
  transit packet totals: receive 0, send 0
  transit byte totals: receive 0, send 0
  transit packet drops: receive 0, seq error 0, send 0

```

The following example shows the currently configured APS groups on the router:

```

Router# show aps

SONET 0/0/16 APS Group 25: protect channel 0 (Inactive) (HA)
Working channel 1 at 10.1.1.1 (Enabled) (HA)
bidirectional, non-revertive
PGP timers (extended for HA): hello time=1; hold time=10
hello fail revert time=120
Received K1K2: 0x00 0x05
No Request (Null)
Transmitted K1K2: 0x00 0x00
No Request (Null)
Remote APS configuration: (null)
SONET 0/0/2 APS Group 25: working channel 1 (Active) (HA)
Protect at 10.1.1.1
PGP timers (from protect): hello time=1; hold time=10
Remote APS configuration: (null)

```

### Configuring VT 1.5-T1 Loopback

To configure VT 1.5-T1 loopback, use the following commands:

```

enable
configure terminal
controller sonet 0/0/16
rate oc3
no ais shut
alarm- report all
framing sonet
clock source internal
sts-1 1
clock source internal
mode vt-15

```

```
vtg 1 t1 1 loopback local
end
```

### Configuring VT 1.5-T1 BERT

To configure VT 1.5-T1 BERT, use the following commands:

```
enable
configure terminal
controller sonet 0/0/16
rate oc3
no ais shut
alarm- report all
framing sonet
clock source internal
sts-1 1
clock source internal
mode vt-15
vtg 1 t1 1 bert pattern 2^11 interval 10
end
```

### Configuring Path Overhead

This section describes the configuration of path overhead.

#### C2 Flag

To configure the C2 flag, use the following commands:

```
enable
configure terminal
controller sonet 0/0/16
sts-1 1
overhead c2 10
end
```

#### J1 Flag

To configure the J1 flag, use the following commands:

```
enable
configure terminal
controller sonet 0/0/16
sts-1 1
overhead j1 expected length
end
```

### Configuring Path Threshold

To configure path threshold, use the following commands:

```
enable
configure terminal
controller sonet 0/0/16
sts-1 1
threshold b3-tca 3
end
```

## Verification of SONET Configuration

The following sample output shows the verification of SONET configuration:

```
Router#show controllers sonet 0/0/16
SONET 0/0/16 is up.                               =====> this is the controller/port
```



```
SONET Line Tables
  INTERVAL      CV    ES    SES    UAS    CVFE    ESFE    SESFE    UASFE
  12:15-12:30   0    0    0    50    0    0    0    0 (FE Invalid)=====> The Far
  End PMON dataset is flagged Invalid due to a Near End alarm.
  12:00-12:15   0    0    0    0    0    0    0    0
  11:45-12:00   48   1    0    0    53   1    0    0 (NE, FE Invalid)
Total of Data in Current and Previous Intervals
48   1    0    50   53   1    0    0 (NE, FE Invalid)
```

High Order Path:

```
PATH 1:
Clock Source is internal          =====> path level clock

  AIS = 0          RDI = 0          REI = 0          BIP(B3) = 0          =====> path
  layer alarms counter
  LOP = 0          PSE = 0          NSE = 0          NEWPTR = 0
  LOM = 0          PLM = 0          UNEQ = 0
```

```
Active Defects: None
Detected Alarms: None
Asserted/Active Alarms: None          =====> present alarms
  on the path.
Alarm reporting enabled for: PAIS PRDI PUNEQ PLOP PPLM LOM B3-TCA
```

```
TCA threshold: B3 = 10e-6
Rx: C2 = 00          =====> rx and tx C2 byte..
Tx: C2 = 02
PATH TRACE BUFFER : UNSTABLE
```

```
  00 00 00 00 00 00 00 00 00 00 00 00 00 00 00 00 ..... =====> path trace of the
path
  00 00 00 00 00 00 00 00 00 00 00 00 00 00 00 00 .....
  00 00 00 00 00 00 00 00 00 00 00 00 00 00 00 00 .....
  00 00 00 00 00 00 00 00 00 00 00 00 00 00 00 00 .....
```

```
SONET Path Tables
  INTERVAL      CV    ES    SES    UAS    CVFE    ESFE    SESFE    UASFE
  12:15-12:30   0    0    0    0    0    0    0    389 (FE Invalid)
  12:00-12:15   0    0    0    0    0    0    0    0
  11:45-12:00   0    1    1    0    0    0    0    900 (NE, FE Invalid)
Total of Data in Current and Previous Intervals
0    1    1    0    0    0    1289 (NE, FE Invalid)
```

```
PATH 2:
Clock Source is internal

  AIS = 0          RDI = 0          REI = 0          BIP(B3) = 0
  LOP = 0          PSE = 0          NSE = 0          NEWPTR = 0
  LOM = 0          PLM = 0          UNEQ = 0
```

```
Active Defects: None
Detected Alarms: None
Asserted/Active Alarms: PLOP
Alarm reporting enabled for: PAIS PRDI PUNEQ PLOP PPLM LOM B3-TCA
```

```
TCA threshold: B3 = 10e-6
Rx: C2 = 00
Tx: C2 = 04
52 6F 75 74 65 72 20 30 2F 32 2F 30 2E 32 00 00 Router 0/2/0.2..
  00 00 00 00 00 00 00 00 00 00 00 00 00 00 00 00 .....
  00 00 00 00 00 00 00 00 00 00 00 00 00 00 00 00 .....
```

00 00 00 00 00 00 00 00 00 00 00 00 00 00 00 00 .....

Expected J1 Length : 64  
 Expected J1 Trace

```

52 6F 75 74 65 72 20 30 2F 32 2F 30 2E 32 00 00 Router 0/2/0.2..
00 00 00 00 00 00 00 00 00 00 00 00 00 00 00 00 .....
00 00 00 00 00 00 00 00 00 00 00 00 00 00 00 00 .....
00 00 00 00 00 00 00 00 00 00 00 00 00 00 00 00 .....
    
```

PATH TRACE BUFFER : UNSTABLE

Rx J1 Length : 0  
 Rx J1 Trace

SONET Path Tables

| INTERVAL  | CV | ES | SES  | UAS | CVFE | ESFE | SESFE | UASFE |                  |
|---|----|----|------|-----|------|------|-------|-------|------------------|
| 12:15-12:30                                     | 0  | 0  | 0    | 389 | 0    | 0    | 0     | 0     | (FE Invalid)     |
| 12:00-12:15                                     | 0  | 0  | 0    | 0   | 0    | 0    | 0     | 0     |                  |
| 11:45-12:00                                     | 0  | 0  | 0    | 900 | 0    | 0    | 0     | 0     | (NE, FE Invalid) |
| Total of Data in Current and Previous Intervals |    |    |      |     |      |      |       |       |                  |
| 0   | 0  | 0  | 1289 | 0   | 0    | 0    | 0     | 0     | (NE, FE Invalid) |

PATH 3:  
 Clock Source is internal

```

AIS = 0          RDI = 0          REI = 0          BIP(B3) = 0
LOP = 1          PSE = 0          NSE = 0          NEWPTR = 0
LOM = 0          PLM = 0          UNEQ = 1
    
```

Active Defects: None  
 Detected Alarms: PLOP LOM  
 Asserted/Active Alarms: PLOP  
 Alarm reporting enabled for: PAIS PRDI PUNEQ PLOP PPLM LOM B3-TCA

TCA threshold: B3 = 10e-6  
 Rx: C2 = 00  
 Tx: C2 = 02

Tx J1 Length : 64  
 Tx J1 Trace

```

52 6F 75 74 65 72 20 30 2F 32 2F 30 2E 33 00 00 Router 0/2/0.3..
00 00 00 00 00 00 00 00 00 00 00 00 00 00 00 00 .....
00 00 00 00 00 00 00 00 00 00 00 00 00 00 00 00 .....
00 00 00 00 00 00 00 00 00 00 00 00 00 00 00 00 .....
    
```

Expected J1 Length : 64  
 Expected J1 Trace

```

52 6F 75 74 65 72 20 30 2F 32 2F 30 2E 33 00 00 Router 0/2/0.3..
00 00 00 00 00 00 00 00 00 00 00 00 00 00 00 00 .....
00 00 00 00 00 00 00 00 00 00 00 00 00 00 00 00 .....
00 00 00 00 00 00 00 00 00 00 00 00 00 00 00 00 .....
    
```

PATH TRACE BUFFER : UNSTABLE

Rx J1 Length : 0  
 Rx J1 Trace

SONET Path Tables

| INTERVAL | CV | ES | SES | UAS | CVFE | ESFE | SESFE | UASFE |  |
|----------|----|----|-----|-----|------|------|-------|-------|--|
|----------|----|----|-----|-----|------|------|-------|-------|--|

```

12:15-12:30      0      0      0      389      0      0      0      0      0 (FE Invalid)
12:00-12:15      0      0      0      0      0      0      0      0      0
11:45-12:00      0      0      0      894      0      0      0      0      0 (NE, FE Invalid)
Total of Data in Current and Previous Intervals
0      0      0      1283      0      0      0      0      0 (NE, FE Invalid)

OC3.STS1 0/0/16 is up.      =====> present status of the path
Hardware is

Applique type is VT1.5      =====> mode of the path

STS-1 1, VTG 1, T1 1 (VT1.5 1/1/1) is down      =====> status of the SPE (t1)
VT Receiver has no alarm.
Receiver is getting AIS.      =====> alarm of the SPE (t1)
Framing is unframed, Clock Source is Internal      =====> framing of the T1, clock of the
t1
Data in current interval (230 seconds elapsed):
Near End
  0 Line Code Violations, 0 Path Code Violations
  0 Slip Secs, 0 Fr Loss Secs, 0 Line Err Secs, 0 Degraded Mins
  0 Errored Secs, 0 Bursty Err Secs, 0 Severely Err Secs, 0 Unavailable Secs
  0 Path Failures, 0 SEF/AIS Secs
Far End
  0 Line Code Violations, 0 Path Code Violations
  0 Slip Secs, 0 Fr Loss Secs, 0 Line Err Secs, 0 Degraded Mins
  0 Errored Secs, 0 Bursty Err Secs, 0 Severely Err Secs, 0 Unavailable Secs
  0 Path Failures
Data in Interval 1:
Near End
  0 Line Code Violations, 0 Path Code Violations
  0 Slip Secs, 0 Fr Loss Secs, 14 Line Err Secs, 0 Degraded Mins
  0 Errored Secs, 0 Bursty Err Secs, 0 Severely Err Secs, 15 Unavailable Secs
  1 Path Failures, 0 SEF/AIS Secs
Far End Data
  0 Line Code Violations, 0 Path Code Violations
  0 Slip Secs, 4 Fr Loss Secs, 2 Line Err Secs, 0 Degraded Mins
  4 Errored Secs, 0 Bursty Err Secs, 4 Severely Err Secs, 0 Unavailable Secs
  0 Path Failures
Total Data (last 1 15 minute intervals):
Near End
  0 Line Code Violations, 0 Path Code Violations,
  0 Slip Secs, 0 Fr Loss Secs, 14 Line Err Secs, 0 Degraded Mins,
  0 Errored Secs, 0 Bursty Err Secs, 0 Severely Err Secs, 15 Unavailable Secs
  1 Path Failures, 0 SEF/AIS Secs
Far End
  0 Line Code Violations, 0 Path Code Violations,
  0 Slip Secs, 4 Fr Loss Secs, 2 Line Err Secs, 0 Degraded Mins,
  4 Errored Secs, 0 Bursty Err Secs, 4 Severely Err Secs, 0 Unavailable Secs
  0 Path Failures

STS-1 1, VTG 1, T1 2 (VT1.5 1/1/2) is down
VT Receiver has no alarm.
Receiver is getting AIS.

```

The following table shows each field and its description.



Table 9: Field Description

| Field   | Description   |
|---|---|
| SONET 0/0/16 is up  | Shows that the SONET controller is operating. The controller's state can be up, down, or administratively down. |
| Port configured rate: OC3   | Shows the rate configured on the port.  |
| SECTION: LOS = 0 LOF = 0 BIP = 0  | Shows the section level alarm counters.   |
| SONET Section Tables:<br>INTERVAL CV ES SES SEFS<br>05:50-05:58 0 0 0 0   | Shows the PMON for the port.  |
| LINE:<br>AIS = 0 RDI = 0 REI = 0 BIP(B2) = 0  | Shows the line level alarm counters.  |
| Asserted/Active Alarms: None  | Shows the active alarms on the port.  |
| BER thresholds: SF = 10e-3 SD = 10e-6   | Shows BER thresholds.   |
| K1 = 00, K2 = 00  | Shows the K1 and K2 values.   |
| PATH 1:<br>Clock Source is internal   | Shows the path level clock.   |
| AIS = 0 RDI = 0 REI = 0 BIP(B3) = 0 LOP = 0 PSE = 0 NSE = 0 NEWPTR = 0 LOM = 0 PLM = 0 UNEQ = 0                               | Shows the path layer alarm counters.  |
| Active Defects: None<br>Detected Alarms: None<br>Asserted/Active Alarms: None<br>Alarm reporting enabled for: PLOP LOM B3-TCA | Shows the alarms on the path.   |
| TCA threshold: B3 = 10e-6<br>Rx: C2 = 00 =====> rx and tx C2 byte..<br>Tx: C2 = 02<br>PATH TRACE BUFFER : UNSTABLE            | shows the Rx and Tx C2 bytes.   |
| 00 00 00 00 00 00 00 00 00 00 00 00 00 00 00 00<br>.....  | Shows the path trace.   |
| OC3.STS1 0/3/3.1 is up.   | Shows the status of the path.   |
| Applique type is VT1.5  | Shows the mode of the path.   |
| STS-1 1, VTG 1, T1 1 (VT1.5 1/1/1) is down  | Shows the status of SPE (T1).   |

| Field   | Description                                  |
|---|--|
| Receiver is getting AIS.                      | Shows the alarm of SPE (T1).                 |
| Framing is unframed, Clock Source is Internal | Shows the framing of T1 and clock of the T1. |

## Configuring CEM Group for Framed SAToP

To configure a CEM group for Framed SAToP:

```
enable
configure terminal
controller mediatype 0/4/16
mode sonet
controller sonet 0/4/16
rate oc12
sts-1 1
mode vt-15
vtg 1 t1 1 cem-group 0 framed
end
```

## Configuring VT-15 mode of STS-1 for Framed SAToP

To configure VT-15 mode of STS-1 for framed SAToP:

```
enable
configure terminal
controller mediatype 0/0/16
mode sonet
controller sonet 0/0/16
rate oc3
sts-1 1
mode vt-15
vtg 1 t1 1 cem-group 0 framed
end
```

## Configuring DS1/T1 CT3 mode of STS-1 for Framed SAToP

To configure DS1/T1 CT3 mode of STS-1 for framed SAToP:

```
enable
configure terminal
controller mediatype 0/0/16
mode sonet
controller sonet 0/0/16
rate oc3
sts-1 2
mode ct3
t3 framing c-bit
t1 1 cem-group 1 framed
end
```

## Configuring CEM APS for Framed SAToP

To configure unidirectional ACR (SONET Framing) for framed SAToP:

```

enable
configure terminal
controller sonet 0/4/16
rate OC3
clock source internal
aps group acr 1
aps working 1
exit
controller sonet 0/4/17
rate OC3
aps group acr 1
aps unidirectional
aps protect 1 10.7.7.7
aps revert 3
aps adm
controller sonet-acr 1
sts-1 1
mode vt-15
vtg 1 t1 1 cem-group 0 framed
end

```

To configure bi-directional ACR (SONET Framing) for Framed SAToP:

```

enable
configure terminal
controller sonet 0/4/16
rate OC3
clock source internal
aps group acr 1
aps working 1
exit
controller sonet 0/4/17
rate OC3
aps group acr 1
aps protect 1 10.7.7.7
controller sonet-acr 1
sts-1 1
mode vt-15
vtg 1 t1 1 cem-group 0 framed
end

```

## Verifying SONET Configuration for Framed SAToP

To verify SONET configuration for Framed SAToP:

```

Router# show running configuration | sec 0/0/16
platform enable controller mediatype 0/0/16 oc3
controller mediatype 0/0/16
mode sonet
controller sonet 0/0/16
rate oc3
no ais-shut
alarm-report all
clock source internal
!
sts-1 1
clock source internal
mode vt-15
vtg 1 t1 1 cem-group 0 framed
!
sts-1 2
clock source internal
mode ct3

```

```

t3 framing c-bit
t3 clock source internal
t1 1 cem-group 1 framed
!
sts-1 3
clock source internal
mode ct3-e1
t3 framing c-bit
t3 clock source internal
e1 1 cem-group 2 framed
interface cem 0/0/16
no ip address
cem 0
!
cem 1
!
cem 2

#Router

```

## Provisioning APS 1+1



**Note** Ensure to follow the steps only in the order provided.

Perform the following generic steps to provision APS 1+1.

- Step 1** Provision a physical controller with mode and rate.
- Step 2** Put controllers into the APS group and define as working or protect.
- Step 3** Setup STS1s on the sonet-acr controller. Cem-group placement is done on the logical port.
- Step 4** Setup ACR or DCR clocking on the physical controllers.
- Step 5** Provision clock recovered configuration under the recovered-clock section.
- Step 6** Apply xconnect under the cem-acr interface.

## Deprovisioning APS 1+1



**Note** Ensure to follow the steps only in the order provided.

Perform the following generic steps to deprovision APS 1+1.

- Step 1** Remove all xconnect under the cem-acr interface.
- Step 2** Remove clock source for all ACR or DCR services under the physical controllers.
- Step 3** Remove the clock recovered lines under the recovered-clock ACR section.
- Step 4** Remove all provisioning under the sonet-acr controller. This step includes cem-group information and mode settings.

- Step 5** Shut down the physical controller setup for Protect, remove APS provisioning, and apply no shut controller.
- Step 6** Shut down the physical controller setup for Working, remove APS provisioning and apply no shut controller.
- Step 7** Remove the *acr XX type* line in the configuration.
- Step 8** Remove the mode SONET from each physical controller media type to restore the controller to its default setup.
- Step 9** Remove ACR completely from the SONET or SDH interfaces. Ensure that you remove ACR from the virtual SONET and SDH controllers.

### SONET Controller

```
config terminal
no controller sonet-acr <group-id>
end
```

The following example shows how to remove ACR completely from the SONET controller:

```
config terminal
no controller sonet-acr 100
end
```

### SDH Controller

```
config terminal
no controller sdh-acr <group-id>
end
```

The following example shows how to remove ACR completely from the SDH controller:

```
config terminal
no controller sdh-acr 100
end
```

---

## Performance Monitoring Use Cases or Deployment Scenarios for SONET

You can view the statistics or error count generated on the TDM lines.

To view the statistics or error count generated, use the **show controller sonet** command:

```
Router# show controller sonet 0/2/0
SONET 0/2/0 is up.
  Hardware is

  Port configured rate: OC3
  Applique type is Channelized Sonet
  Clock Source is Internal
Medium info:
  Type: Sonet, Line Coding: NRZ,
  Alarm Throttling: OFF
SECTION:
  LOS = 0          LOF = 0          BIP(B1) = 0

SONET Section Tables
INTERVAL      CV      ES      SES      SEFS
12:00-12:07   0       0       0       0
11:45-12:00  15      1       0       0 (Invalid)
Total of Data in Current and Previous Intervals
              15      1       0       0 (Invalid)

LINE:
```

```

AIS = 0          RDI = 0          REI = 0          BIP(B2) = 0
Active Defects: None
Detected Alarms: None
Asserted/Active Alarms: None
Alarm reporting enabled for: SLOS SLOF LAIS SF SD LRDI B1-TCA B2-TCA
BER thresholds: SF = 10e-3 SD = 10e-6
TCA thresholds: B1 = 10e-6 B2 = 10e-6
Rx: S1S0 = 00
    K1 = 00,    K2 = 00
    J0 = 00

```

```

RX S1 = 00

```

```

Tx: S1S0 = 00
    K1 = 00,    K2 = 00
    J0 = 04

```

```

Tx J0 Length : 64
Tx J0 Trace :

```

```

52 6F 75 74 65 72 20 20 20 20 20 20 20 20 20 20 20 20 20 20  Router
20 20 20 20 20 20 20 20 20 20 20 20 20 20 20 20 20 20 20 20
20 20 20 20 20 20 20 20 20 20 20 20 20 20 20 20 20 20 20 20
20 20 20 20 20 20 20 20 20 20 20 20 20 20 20 20 20 20 00 00      ..

```

```

Expected J0 Length : 64
Expected J0 Trace :

```

```

52 6F 75 74 65 72 20 20 20 20 20 20 20 20 20 20 20 20 20 20  Router
20 20 20 20 20 20 20 20 20 20 20 20 20 20 20 20 20 20 20 20
20 20 20 20 20 20 20 20 20 20 20 20 20 20 20 20 20 20 20 20
20 20 20 20 20 20 20 20 20 20 20 20 20 20 20 20 20 20 00 00      ..

```

```

Rx J0 Length : 64
Rx J0 Trace :

```

```

01 01 01 01 01 01 01 01 01 01 01 01 01 01 01 01 01 01 01 01  .....
01 01 01 01 01 01 01 01 01 01 01 01 01 01 01 01 01 01 01 01  .....
01 01 01 01 01 01 01 01 01 01 01 01 01 01 01 01 01 01 01 01  .....
01 01 01 01 01 01 01 01 01 01 01 01 01 01 01 01 01 01 00  .....

```

#### SONET Line Tables

| INTERVAL  | CV | ES | SES | UAS | CVFE | ESFE | SESFE | UASFE |                    |
|---|----|----|-----|-----|------|------|-------|-------|--------------------|
| 12:15-12:30                                     | 0  | 0  | 0   | 50  | 0    | 0    | 0     | 0     | 0 (FE Invalid)     |
| 12:00-12:15                                     | 0  | 0  | 0   | 0   | 0    | 0    | 0     | 0     | 0                  |
| 11:45-12:00                                     | 48 | 1  | 0   | 0   | 53   | 1    | 0     | 0     | 0 (NE, FE Invalid) |
| Total of Data in Current and Previous Intervals |    |    |     |     |      |      |       |       |                    |
|   | 48 | 1  | 0   | 50  | 53   | 1    | 0     | 0     | 0 (NE, FE Invalid) |

High Order Path:

```

PATH 1:
Clock Source is internal

```

```

AIS = 0          RDI = 0          REI = 41350871   BIP(B3) = 9
LOP = 0          PSE = 0          NSE = 0         NEWPTR = 0
LOM = 0          PLM = 0          UNEQ = 1

```

```

Active Defects: None
Detected Alarms: None
Asserted/Active Alarms: None
Alarm reporting enabled for: PAIS PRDI PUNEQ PLOP PPLM LOM B3-TCA

```

TCA threshold: B3 = 10e-6  
 Rx: C2 = 04  
 Tx: C2 = 04

Tx J1 Length : 64  
 Tx J1 Trace

```

52 6F 75 74 65 72 20 30 2F 32 2F 30 2E 31 00 00 Router 0/2/0.1..
00 00 00 00 00 00 00 00 00 00 00 00 00 00 00 00 .....
00 00 00 00 00 00 00 00 00 00 00 00 00 00 00 00 .....
00 00 00 00 00 00 00 00 00 00 00 00 00 00 00 00 .....
    
```

Expected J1 Length : 64  
 Expected J1 Trace

```

52 6F 75 74 65 72 20 30 2F 32 2F 30 2E 31 00 00 Router 0/2/0.1..
00 00 00 00 00 00 00 00 00 00 00 00 00 00 00 00 .....
00 00 00 00 00 00 00 00 00 00 00 00 00 00 00 00 .....
00 00 00 00 00 00 00 00 00 00 00 00 00 00 00 00 .....
    
```

PATH TRACE BUFFER : UNSTABLE

Rx J1 Length : 64  
 Rx J1 Trace

```

BB 43 45 5F 31 5F 31 20 30 2F 34 2F 33 2E 31 00 .CE_1_1 0/4/3.1.
00 00 00 00 00 00 00 00 00 00 00 00 00 00 00 00 .....
00 00 00 00 00 00 00 00 00 00 00 00 00 00 00 00 .....
00 00 00 00 00 00 00 00 00 00 00 00 00 00 00 00 .....
    
```

SONET Path Tables

| INTERVAL  | CV | ES | SES | UAS | CVFE | ESFE | SESFE | UASFE                 |
|---|----|----|-----|-----|------|------|-------|-----------------------|
| 12:15-12:30                                     | 0  | 0  | 0   | 0   | 0    | 0    | 0     | 389 (FE Invalid)      |
| 12:00-12:15                                     | 0  | 0  | 0   | 0   | 0    | 0    | 0     | 0                     |
| 11:45-12:00                                     | 0  | 1  | 1   | 0   | 0    | 0    | 0     | 900 (NE, FE Invalid)  |
| Total of Data in Current and Previous Intervals |    |    |     |     |      |      |       |                       |
|   | 0  | 1  | 1   | 0   | 0    | 0    | 0     | 1289 (NE, FE Invalid) |

PATH 2:  
 Clock Source is internal

```

AIS = 0          RDI = 0          REI = 0          BIP(B3) = 0
LOP = 1          PSE = 0          NSE = 0          NEWPTR = 0
LOM = 0          PLM = 0          UNEQ = 1
    
```

Active Defects: None  
 Detected Alarms: PLOP  
 Asserted/Active Alarms: PLOP  
 Alarm reporting enabled for: PAIS PRDI PUNEQ PLOP PPLM LOM B3-TCA

TCA threshold: B3 = 10e-6  
 Rx: C2 = 00  
 Tx: C2 = 04

Tx J1 Length : 64  
 Tx J1 Trace

```

52 6F 75 74 65 72 20 30 2F 32 2F 30 2E 32 00 00 Router 0/2/0.2..
00 00 00 00 00 00 00 00 00 00 00 00 00 00 00 00 .....
00 00 00 00 00 00 00 00 00 00 00 00 00 00 00 00 .....
00 00 00 00 00 00 00 00 00 00 00 00 00 00 00 00 .....
    
```

Expected J1 Length : 64  
 Expected J1 Trace

```

52 6F 75 74 65 72 20 30 2F 32 2F 30 2E 32 00 00 Router 0/2/0.2..
00 00 00 00 00 00 00 00 00 00 00 00 00 00 00 00 .....
00 00 00 00 00 00 00 00 00 00 00 00 00 00 00 00 .....
00 00 00 00 00 00 00 00 00 00 00 00 00 00 00 00 .....

```

PATH TRACE BUFFER : UNSTABLE

Rx J1 Length : 0  
Rx J1 Trace

SONET Path Tables

| INTERVAL  | CV | ES | SES | UAS  | CVFE | ESFE | SESFE | UASFE |                  |
|---|----|----|-----|------|------|------|-------|-------|------------------|
| 12:15-12:30                                     | 0  | 0  | 0   | 389  | 0    | 0    | 0     | 0     | (FE Invalid)     |
| 12:00-12:15                                     | 0  | 0  | 0   | 0    | 0    | 0    | 0     | 0     |                  |
| 11:45-12:00                                     | 0  | 0  | 0   | 900  | 0    | 0    | 0     | 0     | (NE, FE Invalid) |
| Total of Data in Current and Previous Intervals |    |    |     |      |      |      |       |       |                  |
|   | 0  | 0  | 0   | 1289 | 0    | 0    | 0     | 0     | (NE, FE Invalid) |

PATH 3:  
Clock Source is internal

|         |         |          |             |
|---------|---------|----------|-------------|
| AIS = 0 | RDI = 0 | REI = 0  | BIP(B3) = 0 |
| LOP = 1 | PSE = 0 | NSE = 0  | NEWPTR = 0  |
| LOM = 0 | PLM = 0 | UNEQ = 1 |             |

Active Defects: None  
Detected Alarms: PLOP LOM  
Asserted/Active Alarms: PLOP  
Alarm reporting enabled for: PAIS PRDI PUNEQ PLOP PPLM LOM B3-TCA

TCA threshold: B3 = 10e-6  
Rx: C2 = 00  
Tx: C2 = 02

Tx J1 Length : 64  
Tx J1 Trace

```

52 6F 75 74 65 72 20 30 2F 32 2F 30 2E 33 00 00 Router 0/2/0.3..
00 00 00 00 00 00 00 00 00 00 00 00 00 00 00 00 .....
00 00 00 00 00 00 00 00 00 00 00 00 00 00 00 00 .....
00 00 00 00 00 00 00 00 00 00 00 00 00 00 00 00 .....

```

Expected J1 Length : 64  
Expected J1 Trace

```

52 6F 75 74 65 72 20 30 2F 32 2F 30 2E 33 00 00 Router 0/2/0.3..
00 00 00 00 00 00 00 00 00 00 00 00 00 00 00 00 .....
00 00 00 00 00 00 00 00 00 00 00 00 00 00 00 00 .....
00 00 00 00 00 00 00 00 00 00 00 00 00 00 00 00 .....

```

PATH TRACE BUFFER : UNSTABLE

Rx J1 Length : 0  
Rx J1 Trace

SONET Path Tables

| INTERVAL  | CV | ES | SES | UAS | CVFE | ESFE | SESFE | UASFE |                  |
|---|----|----|-----|-----|------|------|-------|-------|------------------|
| 12:15-12:30                                     | 0  | 0  | 0   | 389 | 0    | 0    | 0     | 0     | (FE Invalid)     |
| 12:00-12:15                                     | 0  | 0  | 0   | 0   | 0    | 0    | 0     | 0     |                  |
| 11:45-12:00                                     | 0  | 0  | 0   | 900 | 0    | 0    | 0     | 0     | (NE, FE Invalid) |
| Total of Data in Current and Previous Intervals |    |    |     |     |      |      |       |       |                  |



```
0 0 0 1289 0 0 0 0 (NE, FE Invalid)
```

SONET 0/2/0.1 T3 is down.

```
Applique type is T3
Receiver is getting AIS.
MDL transmission is disabled
```

```
FEAC code received: No code is being received
Framing is C-BIT Parity, Cablelength is 224
BER thresholds: SF = 10e-3 SD = 10e-6
Clock Source is internal
Equipment customer loopback
Data in current interval (390 seconds elapsed):
```

```
Near End
 0 Line Code Violations, 0 P-bit Coding Violations
 0 C-bit Coding Violations, 0 P-bit Err Secs
 0 P-bit Severely Err Secs, 0 Severely Err Framing Secs
389 Unavailable Secs, 0 Line Errored Secs
 0 C-bit Errored Secs, 0 C-bit Severely Errored Secs
 0 Severely Errored Line Secs, 0 Path Failures
 0 AIS Defect Secs, 0 LOS Defect Secs
Far End
 0 Errored Secs, 0 Severely Errored Secs
 0 C-bit Unavailable Secs, 0 Path Failures
 0 Code Violations, 0 Service Affecting Secs
```

Data in Interval 1:

```
Near End
 0 Line Code Violations, 0 P-bit Coding Violations
 0 C-bit Coding Violations, 0 P-bit Err Secs
 0 P-bit Severely Err Secs, 0 Severely Err Framing Secs
910 Unavailable Secs, 0 Line Errored Secs
 0 C-bit Errored Secs, 0 C-bit Severely Errored Secs
 0 Severely Errored Line Secs, 1 Path Failures
 0 AIS Defect Secs, 0 LOS Defect Secs
Far End
 0 Errored Secs, 0 Severely Errored Secs
 0 C-bit Unavailable Secs, 0 Path Failures
 0 Code Violations, 0 Service Affecting Secs
```

Total Data (last 1 15 minute intervals):

```
Near End
 0 Line Code Violations, 0 P-bit Coding Violations,
 0 C-bit Coding Violations, 0 P-bit Err Secs,
 0 P-bit Severely Err Secs, 0 Severely Err Framing Secs,
910 Unavailable Secs, 0 Line Errored Secs,
 0 C-bit Errored Secs, 0 C-bit Severely Errored Secs
 0 Severely Errored Line Secs, 1 path failures
 0 AIS Defect Secs, 0 LOS Defect Secs
Far End
 0 Errored Secs, 0 Severely Errored Secs
 0 C-bit Unavailable Secs, 0 Path Failures
 0 Code Violations, 0 Service Affecting Secs
```

T1 1 is up

timeslots:

FDL per AT&T 54016 spec.

No alarms detected.

Framing is ESF, Clock Source is Internal

Data in current interval (250 seconds elapsed):

```
Near End
 0 Line Code Violations, 0 Path Code Violations
 0 Slip Secs, 0 Fr Loss Secs, 0 Line Err Secs, 0 Degraded Mins
```

```

    0 Errored Secs, 0 Bursty Err Secs, 0 Severely Err Secs
    0 Unavailable Secs, 0 Stuffed Secs
    0 Path Failures, 0 SEF/AIS Secs
  Far End
    0 Line Code Violations, 0 Path Code Violations
    0 Slip Secs, 0 Fr Loss Secs, 0 Line Err Secs, 0 Degraded Mins
    0 Errored Secs, 0 Bursty Err Secs, 0 Severely Err Secs
    0 Unavailable Secs 0 Path Failures
Data in Interval 1:
  Near End
    0 Line Code Violations, 0 Path Code Violations
    0 Slip Secs, 2 Fr Loss Secs, 0 Line Err Secs, 0 Degraded Mins
    2 Errored Secs, 0 Bursty Err Secs, 2 Severely Err Secs
    0 Unavailable Secs, 0 Stuffed Secs
    1 Path Failures, 2 SEF/AIS Secs
  Far End
    0 Line Code Violations, 0 Path Code Violations
    0 Slip Secs, 2 Fr Loss Secs, 0 Line Err Secs, 0 Degraded Mins
    3 Errored Secs, 0 Bursty Err Secs, 3 Severely Err Secs
    0 Unavailable Secs 0 Path Failures
Total Data (last 1 15 minute intervals):
  Near End
    0 Line Code Violations,0 Path Code Violations,
    0 Slip Secs, 2 Fr Loss Secs, 0 Line Err Secs, 0 Degraded Mins,
    2 Errored Secs, 0 Bursty Err Secs, 2 Severely Err Secs
    0 Unavailable Secs, 0 Stuffed Secs
    1 Path Failures, 2 SEF/AIS Secs
  Far End
    0 Line Code Violations,0 Path Code Violations
    0 Slip Secs, 2 Fr Loss Secs, 0 Line Err Secs, 0 Degraded Mins,
    3 Errored Secs, 0 Bursty Err Secs, 3 Severely Err Secs
    0 Unavailable Secs, 0 Path Failures

SONET 0/2/0.2 T3 is down.
Hardware is

Applique type is Channelized T3 to T1
Receiver is getting AIS.
MDL transmission is disabled

FEAC code received: No code is being received
Framing is C-BIT Parity, Cablelength is 224
BER thresholds: SF = 10e-3 SD = 10e-6
Clock Source is internal
Equipment customer loopback
Data in current interval (400 seconds elapsed):
  Near End
    0 Line Code Violations, 0 P-bit Coding Violations
    0 C-bit Coding Violations, 0 P-bit Err Secs
    0 P-bit Severely Err Secs, 0 Severely Err Framing Secs
    399 Unavailable Secs, 0 Line Errored Secs
    0 C-bit Errored Secs, 0 C-bit Severely Errored Secs
    0 Severely Errored Line Secs, 0 Path Failures
    0 AIS Defect Secs, 0 LOS Defect Secs
  Far End
    0 Errored Secs, 0 Severely Errored Secs
    0 C-bit Unavailable Secs, 0 Path Failures
    0 Code Violations, 0 Service Affecting Secs
Data in Interval 1:
  Near End
    0 Line Code Violations, 0 P-bit Coding Violations
    0 C-bit Coding Violations, 0 P-bit Err Secs
    0 P-bit Severely Err Secs, 0 Severely Err Framing Secs
    910 Unavailable Secs, 0 Line Errored Secs

```

```

    0 C-bit Errored Secs, 0 C-bit Severely Errored Secs
    0 Severely Errored Line Secs, 1 Path Failures
    0 AIS Defect Secs, 0 LOS Defect Secs
Far End
    0 Errored Secs, 0 Severely Errored Secs
    0 C-bit Unavailable Secs, 0 Path Failures
    0 Code Violations, 0 Service Affecting Secs
Total Data (last 1 15 minute intervals):
Near End
    0 Line Code Violations, 0 P-bit Coding Violations,
    0 C-bit Coding Violations, 0 P-bit Err Secs,
    0 P-bit Severely Err Secs, 0 Severely Err Framing Secs,
    910 Unavailable Secs, 0 Line Errored Secs,
    0 C-bit Errored Secs, 0 C-bit Severely Errored Secs
    0 Severely Errored Line Secs, 1 path failures
    0 AIS Defect Secs, 0 LOS Defect Secs
Far End
    0 Errored Secs, 0 Severely Errored Secs
    0 C-bit Unavailable Secs, 0 Path Failures
    0 Code Violations, 0 Service Affecting Secs
T1 1 is up
timeslots:
FDL per AT&T 54016 spec.
No alarms detected.
Framing is ESF, Clock Source is Internal
Data in current interval (250 seconds elapsed):
Near End
    0 Line Code Violations, 0 Path Code Violations
    0 Slip Secs, 0 Fr Loss Secs, 0 Line Err Secs, 0 Degraded Mins
    0 Errored Secs, 0 Bursty Err Secs, 0 Severely Err Secs
    0 Unavailable Secs, 0 Stuffed Secs
    0 Path Failures, 0 SEF/AIS Secs
Far End
    0 Line Code Violations, 0 Path Code Violations
    0 Slip Secs, 0 Fr Loss Secs, 0 Line Err Secs, 0 Degraded Mins
    0 Errored Secs, 0 Bursty Err Secs, 0 Severely Err Secs
    0 Unavailable Secs 0 Path Failures
Data in Interval 1:
Near End
    0 Line Code Violations, 0 Path Code Violations
    0 Slip Secs, 2 Fr Loss Secs, 0 Line Err Secs, 0 Degraded Mins
    2 Errored Secs, 0 Bursty Err Secs, 2 Severely Err Secs
    0 Unavailable Secs, 0 Stuffed Secs
    1 Path Failures, 2 SEF/AIS Secs
Far End
    0 Line Code Violations, 0 Path Code Violations
    0 Slip Secs, 2 Fr Loss Secs, 0 Line Err Secs, 0 Degraded Mins
    3 Errored Secs, 0 Bursty Err Secs, 3 Severely Err Secs
    0 Unavailable Secs 0 Path Failures
Total Data (last 1 15 minute intervals):
Near End
    0 Line Code Violations,0 Path Code Violations,
    0 Slip Secs, 2 Fr Loss Secs, 0 Line Err Secs, 0 Degraded Mins,
    2 Errored Secs, 0 Bursty Err Secs, 2 Severely Err Secs
    0 Unavailable Secs, 0 Stuffed Secs
    1 Path Failures, 2 SEF/AIS Secs
Far End
    0 Line Code Violations,0 Path Code Violations
    0 Slip Secs, 2 Fr Loss Secs, 0 Line Err Secs, 0 Degraded Mins,
    3 Errored Secs, 0 Bursty Err Secs, 3 Severely Err Secs
    0 Unavailable Secs, 0 Path Failures
STS-1 2, T1 1 (CT3 2-1) is down
timeslots:
FDL per ANSI T1.403 and AT&T 54016 spec.

```

```

Receiver is getting AIS.
Framing is ESF, Clock Source is Internal
Data in current interval (390 seconds elapsed):
Near End
  0 Line Code Violations, 0 Path Code Violations
  0 Slip Secs, 0 Fr Loss Secs, 0 Line Err Secs, 0 Degraded Mins
  0 Errored Secs, 0 Bursty Err Secs, 0 Severely Err Secs
  389 Unavailable Secs, 0 Stuffed Secs
Far End
  0 Line Code Violations, 0 Path Code Violations
  0 Slip Secs, 0 Fr Loss Secs, 0 Line Err Secs, 0 Degraded Mins
  0 Errored Secs, 0 Bursty Err Secs, 0 Severely Err Secs
  0 Unavailable Secs
Data in Interval 1:
Near End
  0 Line Code Violations, 0 Path Code Violations
  0 Slip Secs, 0 Fr Loss Secs, 0 Line Err Secs, 0 Degraded Mins
  0 Errored Secs, 0 Bursty Err Secs, 0 Severely Err Secs
  900 Unavailable Secs, 0 Stuffed Secs
Far End
  0 Line Code Violations, 0 Path Code Violations
  0 Slip Secs, 0 Fr Loss Secs, 0 Line Err Secs, 0 Degraded Mins
  0 Errored Secs, 0 Bursty Err Secs, 0 Severely Err Secs
  0 Unavailable Secs
Total Data (last 1 15 minute intervals):
Near End
  0 Line Code Violations,0 Path Code Violations,
  0 Slip Secs, 0 Fr Loss Secs, 0 Line Err Secs, 0 Degraded Mins,
  0 Errored Secs, 0 Bursty Err Secs, 0 Severely Err Secs
  900 Unavailable Secs, 0 Stuffed Secs
Far End
  0 Line Code Violations,0 Path Code Violations
  0 Slip Secs, 0 Fr Loss Secs, 0 Line Err Secs, 0 Degraded Mins,
  0 Errored Secs, 0 Bursty Err Secs, 0 Severely Err Secs
  0 Unavailable Secs

```

To view the performance monitoring details on SONET, use the **show controller sonet tabular** command:

```

Router#show controllers sonet 0/7/19 tabular

SONET 0/7/19 is up.
  Hardware is A900-IMA3G-IMSG NCS4200-3GMS

Port configured rate: OC3
Applique type is Channelized Sonet
Clock Source is Internal
Medium info:
  Type: Sonet, Line Coding: NRZ,
  Alarm Throttling: OFF
SECTION:
  LOS = 0           LOF = 0           BIP(B1) = 0

SONET Section Tables
INTERVAL   CV-S   ES-S   SES-S   SEFS-S
11:33-11:47   0     0     0     0 (NE, FE Invalid)

LINE:
  AIS = 0           RDI = 0           REI = 0           BIP(B2) = 0
Active Defects: None
Detected Alarms: None
Asserted/Active Alarms: None
Alarm reporting enabled for: SLOS SLOF LAIS SF SD LRDI B1-TCA B2-TCA
BER thresholds:  SF = 10e-3  SD = 10e-6
TCA thresholds:  B1 = 10e-6  B2 = 10e-6

```



```

00 00 00 00 00 00 00 00 00 00 00 00 00 00 00 00 .....
00 00 00 00 00 00 00 00 00 00 00 00 00 00 00 00 .....

Expected J1 Length : 64
Expected J1 Trace

50 45 32 20 30 2F 37 2F 31 39 2E 31 00 00 00 00 PE2 0/7/19.1....
00 00 00 00 00 00 00 00 00 00 00 00 00 00 00 00 .....
00 00 00 00 00 00 00 00 00 00 00 00 00 00 00 00 .....
00 00 00 00 00 00 00 00 00 00 00 00 00 00 00 00 .....

Rx J1 Length : 64
Rx J1 Trace

50 45 32 20 30 2F 39 2F 37 2E 31 00 00 00 00 00 PE2 0/9/7.1....
00 00 00 00 00 00 00 00 00 00 00 00 00 00 00 00 .....
00 00 00 00 00 00 00 00 00 00 00 00 00 00 00 00 .....
00 00 00 00 00 00 00 00 00 00 00 00 00 00 00 00 .....

SONET Path Tables
INTERVAL      CV-P  ES-P  SES-P  UAS-P  CV-PFE  ES-PFE  SES-PFE  UAS-PFE
11:33-11:47    0     0     0     0     0       0       0       0       0 (NE, FE Invalid)

PATH 2:
Clock Source is internal

AIS = 0          RDI = 0          REI = 0          BIP(B3) = 0
LOM = 0         PLM = 0         UNEQ = 0         LOP = 0

Active Defects: None
Detected Alarms: None
Asserted/Active Alarms: None
Alarm reporting enabled for: PAIS PRDI PUNEQ PLOP PPLM LOM B3-SF B3-SD B3-TCA

BER threshold: SF = 10e-3 SD = 10e-6
TCA threshold: B3 = 10e-6
Rx: C2 = 00
Tx: C2 = 00

Tx J1 Length : 64
Tx J1 Trace

50 45 32 20 30 2F 37 2F 31 39 2E 32 00 00 00 00 PE2 0/7/19.2....
00 00 00 00 00 00 00 00 00 00 00 00 00 00 00 00 .....
00 00 00 00 00 00 00 00 00 00 00 00 00 00 00 00 .....
00 00 00 00 00 00 00 00 00 00 00 00 00 00 00 00 .....

Expected J1 Length : 64
Expected J1 Trace

50 45 32 20 30 2F 37 2F 31 39 2E 32 00 00 00 00 PE2 0/7/19.2....
00 00 00 00 00 00 00 00 00 00 00 00 00 00 00 00 .....
00 00 00 00 00 00 00 00 00 00 00 00 00 00 00 00 .....
00 00 00 00 00 00 00 00 00 00 00 00 00 00 00 00 .....

Rx J1 Length : 0
Rx J1 Trace

SONET Path Tables
INTERVAL      CV-P  ES-P  SES-P  UAS-P  CV-PFE  ES-PFE  SES-PFE  UAS-PFE
11:47-11:47    0     0     0     0     0       0       0       0       0 (NE, FE Invalid)

PATH 3:

```

Clock Source is internal

AIS = 0            RDI = 0            REI = 0            BIP(B3) = 0  
 LOM = 0           PLM = 0            UNEQ = 0          LOP = 0

Active Defects: None  
 Detected Alarms: None  
 Asserted/Active Alarms: None  
 Alarm reporting enabled for: PAIS PRDI PUNEQ PLOP PPLM LOM B3-SF B3-SD B3-TCA

BER threshold: SF = 10e-3 SD = 10e-6  
 TCA threshold: B3 = 10e-6  
 Rx: C2 = 00  
 Tx: C2 = 00

Tx J1 Length : 64  
 Tx J1 Trace

```

50 45 32 20 30 2F 37 2F 31 39 2E 33 00 00 00 00      PE2 0/7/19.3....
00 00 00 00 00 00 00 00 00 00 00 00 00 00 00 00      .....
00 00 00 00 00 00 00 00 00 00 00 00 00 00 00 00      .....
00 00 00 00 00 00 00 00 00 00 00 00 00 00 00 00      .....
    
```

Expected J1 Length : 64  
 Expected J1 Trace

```

50 45 32 20 30 2F 37 2F 31 39 2E 33 00 00 00 00      PE2 0/7/19.3....
00 00 00 00 00 00 00 00 00 00 00 00 00 00 00 00      .....
00 00 00 00 00 00 00 00 00 00 00 00 00 00 00 00      .....
00 00 00 00 00 00 00 00 00 00 00 00 00 00 00 00      .....
    
```

Rx J1 Length : 0  
 Rx J1 Trace

SONET Path Tables

| INTERVAL    | CV-P | ES-P | SES-P | UAS-P | CV-PFE | ES-PFE | SES-PFE | UAS-PFE            |
|-------------|------|------|-------|-------|--------|--------|---------|--------------------|
| 11:47-11:47 | 0    | 0    | 0     | 0     | 0      | 0      | 0       | 0 (NE, FE Invalid) |

SONET 0/7/19.1 T3 is up.  
 Hardware is NCS4200-3GMS

Applique type is T3  
 No alarms detected.  
 MDL transmission is disabled

FEAC code received: No code is being received  
 Framing is C-BIT Parity, Cablelength is 224  
 BER thresholds: SF = 10e-3 SD = 10e-6  
 Clock Source is internal

Equipment customer loopback

Near End Data

| INTERVAL    | CV-L | ES-L | SES-L | LOSS-L      | CVP-P | CVCP-P | ESP-P | ESCP-P | SESP-P | SESCP-P | SAS-P |
|-------------|------|------|-------|-------------|-------|--------|-------|--------|--------|---------|-------|
| 11:33-11:47 | 0    | 0    | 0     | 0           | 0     | 0      | 0     | 0      | 0      | 0       | 0     |
|             | 0    | 0    | 0     | 0 (Invalid) |       |        |       |        |        |         |       |

Far End Data

| INTERVAL    | CVCP-PFE | ESCP-PFE | SESCP-PFE | UASCP-PFE | FCCP-PFE | SASCP-PFE   |
|-------------|----------|----------|-----------|-----------|----------|-------------|
| 11:33-11:47 | 0        | 0        | 0         | 0         | 0        | 0 (Invalid) |

Table 10: Feature History

| Feature Name                                | Release Information           | Description   |
|---|-------------------------------|---|
| GR-820-CORE specific Performance Monitoring | Cisco IOS XE Bengaluru 17.5.1 | The <b>show controller tabular</b> enables you to view the performance monitoring details in tabular form as per GR-820-Core standards. |

To view the performance monitoring details on T3 interface, use the **show controller t3 tabular** command:

```
Router#show controllers t3 0/7/12 tabular
T3 0/7/12 is down.
Hardware is
Applique type is Subrate T3
Receiver has loss of signal.
MDL transmission is disabled

FEAC code received: No code is being received
Framing is C-BIT Parity, Line Code is B3ZS, Cablelength Short less than 225ft
BER thresholds: SF = 10e-3 SD = 10e-6
Clock Source is internal
Equipment customer loopback
Near End Data
INTERVAL      CV-L  ES-L  SES-L  LOSS-L  CVP-P  CVCP-P  ESP-P  ESCP-P  SESP-P  SESP-P  SAS-P
AISS-P  FC-P  UASP-P  UASCP-P
11:33-11:46      0   779   779   779      0     0     0     0     0     0     0
              0   0   779   779 (Invalid)
Far End Data
INTERVAL      CVCP-PFE  ESCP-PFE  SESP-PFE  UASCP-PFE  FCCP-PFE  SASCP-PFE
11:33-11:46      0           0           0           0           0           0 (Invalid)
```

To view the performance monitoring details on T1 interface, use the **show controller t1 tabular** command:

```
Router#show controllers t1 0/7/0 tabular
T1 0/7/0 is down
Applique type is
Receiver has loss of signal.
alarm-trigger is not set
Soaking time: 3, Clearance time: 10
Framing is ESF, Line Code is B8ZS, Clock Source is Line.
BER thresholds: SF = 10e-3 SD = 10e-6
Near End Data
INTERVAL      CV-L  ES-L  CV-P  ES-P  SES-P  CSS-P  SAS-P  UAS-P  FC-P
10:48-10:57      0   530      0     0     0     0     0     530     1 (Invalid)
Far End Data
INTERVAL      ES-LFE  ES-PFE  SES-PFE  SEFS-PFE  CSS-PFE  UAS-PFE  FC-PFE
10:48-10:57      0           0           0           0           0           0 (Invalid)
```

Starting with Cisco IOS XE 17.11.1, you can view the previous day performance monitoring details using the following **show controller** commands for the T1 or E1, T3 or E3, and SONET controllers.

- show controllers sonet
- show controllers sonet tabular
- show controllers sonet remote performance
- show controllers sonet remote performance tabular

```
router#show controllers sonet 0/3/0
SONET 0/3/0 is down.
```



Hardware is  
 Port configured rate: OC3  
 Applique type is Channelized Sonet  
 Clock Source is Internal  
 Medium info:  
 Type: Sonet, Line Coding: NRZ,  
 Alarm Throttling: OFF  
 SECTION:  
 LOS = 1                      LOF = 0                                      BIP(B1) = 0

SONET Section Tables

| INTERVAL  | CV | ES    | SES   | SEFS  |                  |
|---|----|-------|-------|-------|------------------|
| 06:14-06:24                                     | 0  | 611   | 611   | 611   |                  |
| 05:59-06:14                                     | 0  | 901   | 901   | 901   |                  |
| .....   |    |       |       |       |                  |
| 06:29-06:44                                     | 0  | 901   | 901   | 901   |                  |
| 06:14-06:29                                     | 0  | 901   | 901   | 901   | (NE, FE Invalid) |
| Total of Data in Current and Previous Intervals |    |       |       |       |                  |
|   | 0  | 87107 | 87107 | 87107 | (NE, FE Invalid) |
| Total (Previous Day)                            |    |       |       |       |                  |
| 05:29-05:29                                     | 0  | 86494 | 86494 | 86494 | (NE, FE Invalid) |

LINE:  
 AIS = 0                      RDI = 0                      REI = 0                      BIP(B2) = 0  
 Active Defects: None  
 Detected Alarms: SLOS SLOF LAIS  
 Asserted/Active Alarms: SLOS

SONET Line Tables

| INTERVAL  | CV | ES | SES | UAS   | CVFE | ESFE | SESFE | UASFE |                  |
|---|----|----|-----|-------|------|------|-------|-------|------------------|
| 06:14-06:24                                     | 0  | 0  | 0   | 611   | 0    | 0    | 0     | 0     |                  |
| 05:59-06:14                                     | 0  | 0  | 0   | 901   | 0    | 0    | 0     | 0     |                  |
| 05:44-05:59                                     | 0  | 0  | 0   | 901   | 0    | 0    | 0     | 0     |                  |
| 05:29-05:44                                     | 0  | 0  | 0   | 901   | 0    | 0    | 0     | 0     |                  |
| .....   |    |    |     |       |      |      |       |       |                  |
| 06:14-06:29                                     | 0  | 0  | 0   | 901   | 0    | 0    | 0     | 0     | (NE, FE Invalid) |
| Total of Data in Current and Previous Intervals |    |    |     |       |      |      |       |       |                  |
|   | 0  | 0  | 0   | 87107 | 0    | 0    | 0     | 0     | (NE, FE Invalid) |
| Total (Previous Day)                            |    |    |     |       |      |      |       |       |                  |
| 05:29-05:29                                     | 0  | 0  | 0   | 86494 | 0    | 0    | 0     | 0     | (NE, FE Invalid) |

PATH 1:  
 Clock Source is internal

AIS = 0                      RDI = 0                      REI = 0                      BIP(B3) = 8  
 LOM = 0                      PLM = 0                      UNEQ = 0                      LOP = 0  
 .....

SONET Path Tables

| INTERVAL  | CV | ES | SES | UAS   | CVFE | ESFE | SESFE | UASFE |                  |
|---|----|----|-----|-------|------|------|-------|-------|------------------|
| 06:14-06:24                                     | 0  | 0  | 0   | 609   | 0    | 0    | 0     | 0     |                  |
| 05:59-06:14                                     | 0  | 0  | 0   | 901   | 0    | 0    | 0     | 0     |                  |
| 05:44-05:59                                     | 0  | 0  | 0   | 900   | 0    | 0    | 0     | 0     |                  |
| 05:29-05:44                                     | 0  | 0  | 0   | 901   | 0    | 0    | 0     | 0     |                  |
| .....   |    |    |     |       |      |      |       |       |                  |
| 06:29-06:44                                     | 0  | 0  | 0   | 900   | 0    | 0    | 0     | 0     |                  |
| 06:14-06:29                                     | 0  | 0  | 0   | 900   | 0    | 0    | 0     | 0     | (NE, FE Invalid) |
| Total of Data in Current and Previous Intervals |    |    |     |       |      |      |       |       |                  |
|   | 0  | 0  | 0   | 87045 | 0    | 0    | 0     | 0     | (NE, FE Invalid) |
| Total (Previous Day)                            |    |    |     |       |      |      |       |       |                  |
| 05:29-05:29                                     | 0  | 0  | 0   | 86435 | 0    | 0    | 0     | 0     | (NE, FE Invalid) |

```

PATH 2:
Clock Source is internal
.....

SONET 0/3/0.1 PATH is down.
Hardware is

Applique type is VT1.5

STS-1 1, VTG 1, VT 1 (SONET 0/3/0.1/1/1 VT) is down
VT Receiver has LP_AIS.
cep is configured: FALSE cem_id (0)
fwd_alarm_ais :0 fwd_alarm_rai :0, Clock Source is Internal
BIP2-tca:6, BIP2-sf:3, BIP2-sd:6
Tx V5:2
Rx V5:0
Tx J2 Length=64
TX J2 Trace Buffer:
00 00 00 00 00 00 00 00 00 00 00 00 00 00 00 00 .....
00 00 00 00 00 00 00 00 00 00 00 00 00 00 00 00 .....
00 00 00 00 00 00 00 00 00 00 00 00 00 00 00 00 .....
00 00 00 00 00 00 00 00 00 00 00 00 00 00 00 00 .....

Expected J2 Length=64
Expected J2 Trace Buffer:
00 00 00 00 00 00 00 00 00 00 00 00 00 00 00 00 .....
00 00 00 00 00 00 00 00 00 00 00 00 00 00 00 00 .....
00 00 00 00 00 00 00 00 00 00 00 00 00 00 00 00 .....
00 00 00 00 00 00 00 00 00 00 00 00 00 00 00 00 .....

Rx J2 Length=16
RX J2 Trace Buffer:
CRC-7: 0x60 ERROR

C9 79 F7 0F 5F D8 5D D2 D2 7C F6 0E 53 B2 0E 00 .y.._]...S...

Data in current interval (610 seconds elapsed)
Near End
0 CodeViolations, 0 ErrorSecs, 0 Severly Err Secs, 609 Unavailable Secs
Far End
0 CodeViolations, 0 ErrorSecs, 0 Severly Err Secs, 0 Unavailable Secs
Data in Interval 1:
Near End
0 CodeViolations, 0 ErrorSecs, 0 Severly Err Secs, 901 Unavailable Secs
Far End
0 CodeViolations, 0 ErrorSecs, 0 Severly Err Secs, 0 Unavailable Secs
.....
Data in Interval 96:
Near End
0 CodeViolations, 0 ErrorSecs, 0 Severly Err Secs, 900 Unavailable Secs
Far End
0 CodeViolations, 0 ErrorSecs, 0 Severly Err Secs, 0 Unavailable Secs
Total Data (last 96 fifteen minute intervals):
Near End
0 CodeViolations, 0 ErrorSecs, 0 Severly Err Secs, 86436 Unavailable Secs
Far End
0 CodeViolations, 0 ErrorSecs, 0 Severly Err Secs, 0 Unavailable Secs
Total (Previous Day):
Near End
0 CodeViolations, 0 ErrorSecs, 0 Severly Err Secs, 86435 Unavailable Secs
Far End
0 CodeViolations, 0 ErrorSecs, 0 Severly Err Secs, 0 Unavailable Secs

```

```

STS-1 1, VTG 1, T1 1 (SONET 0/3/0.1/1/1 T1) is down
timeslots: 1-4
FDL per AT&T 54016 spec.
Receiver is getting AIS.
Framing is ESF, Clock Source is Internal
Data in current interval (610 seconds elapsed):
  Near End
    0 Line Code Violations, 0 Path Code Violations
    0 Slip Secs, 0 Fr Loss Secs, 0 Line Err Secs, 0 Degraded Mins
    0 Errored Secs, 0 Bursty Err Secs, 0 Severely Err Secs
    609 Unavail Secs, 0 Stuffed Secs
  Far End
    0 Line Code Violations, 0 Path Code Violations
    0 Slip Secs, 0 Fr Loss Secs, 0 Line Err Secs, 0 Degraded Mins
    0 Errored Secs, 0 Bursty Err Secs, 0 Severely Err Secs
    0 Unavail Secs
Data in Interval 1:
  Near End
    0 Line Code Violations, 0 Path Code Violations
.....
  Far End
    0 Line Code Violations, 0 Path Code Violations
    0 Slip Secs, 0 Fr Loss Secs, 0 Line Err Secs, 0 Degraded Mins
    0 Errored Secs, 0 Bursty Err Secs, 0 Severely Err Secs
    0 Unavail Secs
Data in Interval 96:
  Near End
    0 Line Code Violations, 0 Path Code Violations
    0 Slip Secs, 0 Fr Loss Secs, 0 Line Err Secs, 0 Degraded Mins
    0 Errored Secs, 0 Bursty Err Secs, 0 Severely Err Secs
    900 Unavail Secs, 0 Stuffed Secs
  Far End
    0 Line Code Violations, 0 Path Code Violations
    0 Slip Secs, 0 Fr Loss Secs, 0 Line Err Secs, 0 Degraded Mins
    0 Errored Secs, 0 Bursty Err Secs, 0 Severely Err Secs
    0 Unavail Secs
Total Data (last 24 hours)
  Near End
    0 Line Code Violations,0 Path Code Violations,
    0 Slip Secs, 0 Fr Loss Secs, 0 Line Err Secs, 0 Degraded Mins,
    0 Errored Secs, 0 Bursty Err Secs, 0 Severely Err Secs
    86436 Unavail Secs, 0 Stuffed Secs
  Far End
    0 Line Code Violations,0 Path Code Violations
    0 Slip Secs, 0 Fr Loss Secs, 0 Line Err Secs, 0 Degraded Mins,
    0 Errored Secs, 0 Bursty Err Secs, 0 Severely Err Secs
    0 Unavailable Secs
Total (Previous Day)
  Near End
    0 Line Code Violations,0 Path Code Violations,
    0 Slip Secs, 0 Fr Loss Secs, 0 Line Err Secs, 0 Degraded Mins,
    0 Errored Secs, 0 Bursty Err Secs, 0 Severely Err Secs
    86435 Unavail Secs, 0 Stuffed Secs
  Far End
    0 Line Code Violations,0 Path Code Violations
    0 Slip Secs, 0 Fr Loss Secs, 0 Line Err Secs, 0 Degraded Mins,
    0 Errored Secs, 0 Bursty Err Secs, 0 Severely Err Secs
    0 Unavailable Secs

STS-1 1, VTG 1, VT 2 (SONET 0/3/0.1/1/2 VT) is down
VT Receiver has LP_AIS.

```

router#show controllers sonet 0/3/0 tabular

Section/Line/Path same as previous.

SONET 0/3/0.1 PATH is down.  
Hardware is

Applique type is VT1.5

STS-1 1, VTG 1, VT 1 (SONET 0/3/0.1/1/1 VT) is down  
VT Receiver has LP\_AIS.  
cep is configured: FALSE cem\_id (0)  
fwd\_alarm\_ais :0 fwd\_alarm\_rai :0, Clock Source is Internal  
BIP2-tca:6, BIP2-sf:3, BIP2-sd:6

Tx V5:2  
Rx V5:0  
Tx J2 Length=64  
TX J2 Trace Buffer:  
00 00 00 00 00 00 00 00 00 00 00 00 00 00 00 00 .....  
00 00 00 00 00 00 00 00 00 00 00 00 00 00 00 00 .....  
00 00 00 00 00 00 00 00 00 00 00 00 00 00 00 00 .....  
00 00 00 00 00 00 00 00 00 00 00 00 00 00 00 00 .....

Expected J2 Length=64  
Expected J2 Trace Buffer:  
00 00 00 00 00 00 00 00 00 00 00 00 00 00 00 00 .....  
00 00 00 00 00 00 00 00 00 00 00 00 00 00 00 00 .....  
00 00 00 00 00 00 00 00 00 00 00 00 00 00 00 00 .....  
00 00 00 00 00 00 00 00 00 00 00 00 00 00 00 00 .....

Rx J2 Length=16  
RX J2 Trace Buffer:  
CRC-7: 0x60 ERROR

C9 79 F7 0F 5F D8 5D D2 D2 7C F6 0E 53 B2 0E 00 .y...\_]...|..S...

| INTERVAL              | CV-V | ES-V | SES-V | UAS-V | CV-VFE | ES-VFE | SES-VFE | UAS-VFE |                  |
|-----------------------|------|------|-------|-------|--------|--------|---------|---------|------------------|
| 06:14-06:24           | 0    | 0    | 0     | 619   | 0      | 0      | 0       | 0       |                  |
| 05:59-06:14           | 0    | 0    | 0     | 901   | 0      | 0      | 0       | 0       |                  |
| 05:44-05:59           | 0    | 0    | 0     | 900   | 0      | 0      | 0       | 0       |                  |
| 05:29-05:44           | 0    | 0    | 0     | 901   | 0      | 0      | 0       | 0       |                  |
| 05:14-05:29           | 0    | 0    | 0     | 900   | 0      | 0      | 0       | 0       |                  |
| 04:59-05:14           | 0    | 0    | 0     | 900   | 0      | 0      | 0       | 0       |                  |
| .....                 |      |      |       |       |        |        |         |         |                  |
| 06:44-06:59           | 0    | 0    | 0     | 901   | 0      | 0      | 0       | 0       |                  |
| 06:29-06:44           | 0    | 0    | 0     | 900   | 0      | 0      | 0       | 0       |                  |
| 06:14-06:29           | 0    | 0    | 0     | 900   | 0      | 0      | 0       | 0       | (NE, FE Invalid) |
| Total                 | 0    | 0    | 0     | 86436 | 0      | 0      | 0       | 0       | (NE, FE Invalid) |
| Total (Previous Day): |      |      |       |       |        |        |         |         |                  |
| 05:29-05:29           | 0    | 0    | 0     | 86435 | 0      | 0      | 0       | 0       | (NE, FE Invalid) |

STS-1 1, VTG 1, T1 1 (SONET 0/3/0.1/1/1 T1) is down  
timeslots: 1-4  
FDL per AT&T 54016 spec.  
Receiver is getting AIS.  
Framing is ESF, Clock Source is Internal

Near End Data

| INTERVAL    | CV-L | ES-L | CV-P | ES-P | SES-P | CSS-P | SAS-P | UAS-P | FC-P        |
|-------------|------|------|------|------|-------|-------|-------|-------|-------------|
| 06:14-06:24 | 0    | 0    | 0    | 0    | 0     | 0     | 0     | 619   | 0           |
| 05:59-06:14 | 0    | 0    | 0    | 0    | 0     | 0     | 0     | 901   | 0           |
| .....       |      |      |      |      |       |       |       |       |             |
| 06:44-06:59 | 0    | 0    | 0    | 0    | 0     | 0     | 0     | 901   | 0           |
| 06:29-06:44 | 0    | 0    | 0    | 0    | 0     | 0     | 0     | 900   | 0           |
| 06:14-06:29 | 0    | 0    | 0    | 0    | 0     | 0     | 0     | 900   | 0 (Invalid) |
| Total       | 0    | 0    | 0    | 0    | 0     | 0     | 0     | 86436 | 0 (Invalid) |

```

Total (Previous Day):
05:29-05:29      0      0      0      0      0      0      0      86435      0 (Invalid)
Far End Data
INTERVAL      ES-LFE  ES-PFE  SES-PFE  SEFS-PFE  CSS-PFE  UAS-PFE  FC-PFE
06:14-06:24      0      0      0      0      0      0      0
05:59-06:14      0      0      0      0      0      0      0
.....
06:29-06:44      0      0      0      0      0      0      0
06:14-06:29      0      0      0      0      0      0      0 (Invalid)
Total          0      0      0      0      0      0      0 (Invalid)
Total (Previous Day):
05:29-05:29      0      0      0      0      0      0      0 (Invalid)
    
```

```

STS-1 1, VTG 1, VT 2 (SONET 0/3/0.1/1/2 VT) is down
VT Receiver has LP_AIS.
cep is configured: FALSE cem_id (0)
fwd_alarm_ais :0 fwd_alarm_rai :0, Clock Source is Internal
    
```

router#show controllers sonet 0/3/0 remote performance

Section/Line/Path same as previous.

```

SONET 0/3/0.1 PATH is down.
Hardware is
    
```

```

STS-1 1, VTG 1, VT 1 (VT1.5 1/1/1) - Remote Performance Data
Far end MIB Data:
Data in current interval (630 seconds elapsed)
0 CodeViolations , 0 ErrorSecs,0 Severly Err Secs, 0 Unavail Secs
FarEnd VT Interval data:
Total Data (last 96 15 minute intervals):
0 CodeViolations, 0 ErrorSec, 0 Severly Err Secs, 0 Unavail Secs

Total (Previous Day):
0 CodeViolations, 0 ErrorSec, 0 Severly Err Secs, 0 Unavail Secs
    
```

```

STS-1 1, VTG 1, T1 1 (SONET 0/3/0.1/1/1 T1) - Remote Performance Data
Data in current interval (630 seconds elapsed):
0 Line Code Violations, 0 Path Code Violations
0 Slip Secs, 0 Fr Loss Secs, 0 Line Err Secs, 0 Degraded Mins
0 Errored Secs, 0 Bursty Err Secs, 0 Severly Err Secs
0 Unavail Secs
Data in Interval 1:
.....
Data in Interval 96:
0 Line Code Violations, 0 Path Code Violations
0 Slip Secs, 0 Fr Loss Secs, 0 Line Err Secs, 0 Degraded Mins
0 Errored Secs, 0 Bursty Err Secs, 0 Severly Err Secs
0 Unavail Secs
Total Data (last 24 hours)
0 Path Code Violations
0 Slip Secs, 0 Fr Loss Secs, 0 Line Err Secs, 0 Degraded Mins,
0 Errored Secs, 0 Bursty Err Secs, 0 Severly Err Secs
0 Unavail Secs
Total (Previous Day)
0 Path Code Violations
0 Slip Secs, 0 Fr Loss Secs, 0 Line Err Secs, 0 Degraded Mins,
0 Errored Secs, 0 Bursty Err Secs, 0 Severly Err Secs
0 Unavail Secs
    
```

```

STS-1 1, VTG 1, VT 2 (VT1.5 1/1/2) - Remote Performance Data
Far end MIB Data:
    
```

```

Data in current interval (630 seconds elapsed)
0 CodeViolations , 0 ErrorSecs,0 Severly Err Secs, 0 Unavail Secs
FarEnd VT Interval data:
Total Data (last 96 15 minute intervals):
0 CodeViolations, 0 ErrorSec, 0 Severly Err Secs, 0 Unavail Secs

Total (Previous Day):
0 CodeViolations, 0 ErrorSec, 0 Severly Err Secs, 0 Unavail Secs

```

```
router#show controllers sonet 0/3/0 remote performance tabular
```

```
Section/Line/Path same as previous.
```

```
SONET 0/3/0.1 PATH is down.
Hardware is
```

```
STS-1 1, VTG 1, VT 1 (VT1.5 1/1/1) - Remote Performance Data
```

```
Far end MIB Data:
```

```
INTERVAL      CV      ES      SES      UAS
06:14-06:24   0       0       0       0
```

```
FarEnd VT Interval data:
```

```
INTERVAL      CV      ES      SES      UAS
05:59-06:14   0       0       0       0
```

```
05:44-05:59   0       0       0       0
```

```
05:29-05:44   0       0       0       0
```

```
05:14-05:29   0       0       0       0
```

```
.....
06:29-06:44   0       0       0       0
```

```
06:14-06:29   0       0       0       0
```

```
Total
```

```
CV      ES      SES      UAS      0      0      0      0
```

```
Total (Previous Day)
```

```
CV      ES      SES      UAS      0      0      0      0
```

```
STS-1 1, VTG 1, T1 1 (SONET 0/3/0.1/1/1 T1) - Remote Performance Data
```

```
INTERVAL      LCV      PCV      CSS      SELS      LES      DM      ES      BES      SES      UAS
```

```
06:14-06:24   0       0       0       0       0       0       0       0       0       0
```

```
05:59-06:14   0       0       0       0       0       0       0       0       0       0
```

```
05:44-05:59   0       0       0       0       0       0       0       0       0       0
```

```
.....
06:44-06:59   0       0       0       0       0       0       0       0       0       0
```

```
06:29-06:44   0       0       0       0       0       0       0       0       0       0
```

```
06:14-06:29   0       0       0       0       0       0       0       0       0       0
```

```
Total          0       0       0       0       0       0       0       0       0       0 (NE, FE Invalid)
```

```
Total (Previous Day)
```

```
05:29-05:29   0       0       0       0       0       0       0       0       0       0 (NE, FE Invalid)
```

```
STS-1 1, VTG 1, VT 2 (VT1.5 1/1/2) - Remote Performance Data
```

```
Far end MIB Data:
```

```
INTERVAL      CV      ES      SES      UAS
```

```
06:14-06:24   0       0       0       0 (Invalid)
```

```
FarEnd VT Interval data:
```

```
INTERVAL      CV      ES      SES      UAS
```

```
05:59-06:14   0       0       0       0 (Invalid)
```

## Monitoring Protection Switching Count for Protected SONET Interface

Table 11: Table 1. Feature History

| Feature Name   | Release Information  | Feature Description   |
|--|----------------------|---|
| Protection Switching Count for Protected SONET Interface | Cisco IOS XE 17.15.1 | In SONET with redundancy, an Automatic protection switching (APS) occurs between working and standby protection links due to reasons like a circuit failure. Whenever the switching happens, the switching count is tracked using a Protection Switching Count (PSC) parameter.<br><br>Depending on the PSC count, you can debug the network to identify the reason for extensive switching and work on the corrective actions. |

In addition to alarms, the PSC parameter records the number of times that a SONET traffic is switched between working and protection SONET circuits automatically. APS enables SONET connections to switch to another SONET circuit due to circuit failure reasons. A protection interface serves as the backup interface for the working interface. When the working interface fails, the protection interface quickly assumes its traffic load. For more information on APS, see [Automatic Protection Switching , on page 15](#)

The switching count can be monitored and tracked with respect to performance monitoring at a time interval of every 15 minutes and 24 hours. The higher the PSC value cautions you to check on the SONET network, analyze the failures, and work on correction actions to restore the network. Thus, the PSC count provides a better monitoring package to the administrator.

You can track the PSC parameter under the **SONET Section Tables** in the **show controller sonet** and **show controller sonet tabular** commands.

### Supported Interface Module for PSC Monitoring

PSC monitoring is supported on these interface modules:

### Viewing the PSC Parameter

The sample **show controller sonet** displays a PSC value under **SONET Section Tables**. The PSC value of 2 denotes that switching happened twice for every 15 minutes and the total switching count that occurred on the SONET interface is 4.

```
Router#show controller sonet 0/3/1
SONET 0/3/1 is up.(Configured for Locally Looped)
  Currently in Locally Looped
  Alarm-profile: telcordia
  Sec-admin-state: maintenance, Soak-time: NA,
  soak-Time-left: NA, AINS-state: OOS-MA,LPBK & MT
  Hardware is

Port configured rate: OC3
Applique type is Channelized Sonet
Clock Source is Internal
Medium info:
  Type: Sonet, Line Coding: NRZ,
  Alarm Throttling: OFF
SECTION:
  LOS = 1          LOF = 0          BIP(B1) = 0
```

## SONET Section Tables

| INTERVAL  | CV | ES  | SES | SEFS | PSC         |
|---|----|-----|-----|------|-------------|
| 20:46-20:53                                     | 0  | 170 | 170 | 170  | 2 (Invalid) |
| 20:31-20:46                                     | 0  | 559 | 559 | 559  | 2 (Invalid) |
| Total of Data in Current and Previous Intervals |    |     |     |      |             |
|   | 0  | 729 | 729 | 729  | 4 (Invalid) |

## LINE:

AIS = 0                    RDI = 0                    REI = 12                    BIP(B2) = 36  
 Active Defects: None  
 Detected Alarms: None  
 Asserted/Active Alarms: None  
 Alarm reporting enabled for: SLOS SLOF LAIS SF SD LRDI B1-TCA B2-TCA  
 BER thresholds: SF = 10e-3 SD = 10e-6  
 TCA thresholds: B1 = 10e-6 B2 = 10e-6  
 Rx: SISO = NA  
     K1 = 00,    K2 = 00  
     J0 = 00  
  
     RX S1 = 00  
  
 Tx: SISO = NA  
     K1 = 00,    K2 = 00  
     J0 = 04

Tx J0 Length : 64

Tx J0 Trace :

```

52 6F 75 74 65 72 20 20 20 20 20 20 20 20 20 20 20 20 20 20 Router
20 20 20 20 20 20 20 20 20 20 20 20 20 20 20 20 20 20 20 20
20 20 20 20 20 20 20 20 20 20 20 20 20 20 20 20 20 20 20 20
20 20 20 20 20 20 20 20 20 20 20 20 20 20 20 20 00 00 ..

```

Expected J0 Length : 64

Expected J0 Trace :

```

52 6F 75 74 65 72 20 20 20 20 20 20 20 20 20 20 20 20 20 20 Router
20 20 20 20 20 20 20 20 20 20 20 20 20 20 20 20 20 20 20 20
20 20 20 20 20 20 20 20 20 20 20 20 20 20 20 20 20 20 20 20
20 20 20 20 20 20 20 20 20 20 20 20 20 20 20 20 00 00 ..

```

Rx J0 Length : 64

Rx J0 Trace :

```

52 6F 75 74 65 72 20 20 20 20 20 20 20 20 20 20 20 20 20 20 Router
20 20 20 20 20 20 20 20 20 20 20 20 20 20 20 20 20 20 20 20
20 20 20 20 20 20 20 20 20 20 20 20 20 20 20 20 20 20 20 20
20 20 20 20 20 20 20 20 20 20 20 20 20 20 20 20 0D 00 ..

```

## SONET Line Tables

| INTERVAL    | CV | ES | SES | UAS | CVFE | ESFE | SESFE | UASFE |                  |
|-------------|----|----|-----|-----|------|------|-------|-------|------------------|
| 02:35-02:47 | 0  | 5  | 5   | 0   | 0    | 0    | 0     | 0     | (NE, FE Invalid) |

## PATH 1:

Clock Source is internal

AIS = 0                    RDI = 0                    REI = 0                    BIP(B3) = 0  
 LOM = 0                    PLM = 0                    UNEQ = 0                    LOP = 0

Active Defects: None

Detected Alarms: None

Asserted/Active Alarms: None

Alarm reporting enabled for: PAIS PRDI PUNEQ PLOP PPLM LOM B3-SF B3-SD B3-TCA



BER threshold: SF = 10e-3 SD = 10e-6  
 TCA threshold: B3 = 10e-6  
 Rx: C2 = 00  
 Tx: C2 = 00

Tx J1 Length : 64  
 Tx J1 Trace

```

52 6F 75 74 65 72 20 30 2F 33 2F 31 2E 31 00 00 Router 0/3/1.1..
00 00 00 00 00 00 00 00 00 00 00 00 00 00 00 00 .....
00 00 00 00 00 00 00 00 00 00 00 00 00 00 00 00 .....
00 00 00 00 00 00 00 00 00 00 00 00 00 00 00 00 .....
    
```

Expected J1 Length : 64  
 Expected J1 Trace

```

52 6F 75 74 65 72 20 30 2F 33 2F 31 2E 31 00 00 Router 0/3/1.1..
00 00 00 00 00 00 00 00 00 00 00 00 00 00 00 00 .....
00 00 00 00 00 00 00 00 00 00 00 00 00 00 00 00 .....
00 00 00 00 00 00 00 00 00 00 00 00 00 00 00 00 .....
    
```

Rx J1 Length : 0  
 Rx J1 Trace

PATH 2:  
 Clock Source is internal

```

AIS = 0          RDI = 0          REI = 0          BIP(B3) = 0
LOM = 0          PLM = 0          UNEQ = 0         LOP = 0
    
```

Active Defects: None  
 Detected Alarms: None  
 Asserted/Active Alarms: None  
 Alarm reporting enabled for: PAIS PRDI PUNEQ PLOP PPLM LOM B3-SF B3-SD B3-TCA

BER threshold: SF = 10e-3 SD = 10e-6  
 TCA threshold: B3 = 10e-6  
 Rx: C2 = 00  
 Tx: C2 = 00

Tx J1 Length : 64  
 Tx J1 Trace

```

52 6F 75 74 65 72 20 30 2F 33 2F 31 2E 32 00 00 Router 0/3/1.2..
00 00 00 00 00 00 00 00 00 00 00 00 00 00 00 00 .....
00 00 00 00 00 00 00 00 00 00 00 00 00 00 00 00 .....
00 00 00 00 00 00 00 00 00 00 00 00 00 00 00 00 .....
    
```

Expected J1 Length : 64  
 Expected J1 Trace

```

52 6F 75 74 65 72 20 30 2F 33 2F 31 2E 32 00 00 Router 0/3/1.2..
00 00 00 00 00 00 00 00 00 00 00 00 00 00 00 00 .....
00 00 00 00 00 00 00 00 00 00 00 00 00 00 00 00 .....
00 00 00 00 00 00 00 00 00 00 00 00 00 00 00 00 .....
    
```

Rx J1 Length : 0  
 Rx J1 Trace

PATH 3:  
 Clock Source is internal

```

AIS = 0          RDI = 0          REI = 0          BIP(B3) = 0
LOM = 0          PLM = 0          UNEQ = 0         LOP = 0

Active Defects: None
Detected Alarms: None
Asserted/Active Alarms: None
Alarm reporting enabled for: PAIS PRDI PUNEQ PLOP PPLM LOM B3-SF B3-SD B3-TCA

BER threshold: SF = 10e-3 SD = 10e-6
TCA threshold: B3 = 10e-6
Rx: C2 = 00
Tx: C2 = 00

Tx J1 Length : 64
Tx J1 Trace

 52 6F 75 74 65 72 20 30 2F 33 2F 31 2E 33 00 00      Router 0/3/1.3..
00 00 00 00 00 00 00 00 00 00 00 00 00 00 00 00      .....
00 00 00 00 00 00 00 00 00 00 00 00 00 00 00 00      .....
00 00 00 00 00 00 00 00 00 00 00 00 00 00 00 00      .....

Expected J1 Length : 64
Expected J1 Trace

 52 6F 75 74 65 72 20 30 2F 33 2F 31 2E 33 00 00      Router 0/3/1.3..
00 00 00 00 00 00 00 00 00 00 00 00 00 00 00 00      .....
00 00 00 00 00 00 00 00 00 00 00 00 00 00 00 00      .....
00 00 00 00 00 00 00 00 00 00 00 00 00 00 00 00      .....

Rx J1 Length : 0
Rx J1 Trace

```

The sample **show controller sonet tabular** displays a PSC value under **SONET Section Tables**. The PSC value of 1 denotes that switching happened one time in every 15 minutes and the total switching count that occurred on the SONET interface is 2.

```

Router#show controller sonet 0/3/1 tabular
SONET 0/3/1 is up.(Configured for Locally Looped)
  Currently in Locally Looped
  Hardware is

Port configured rate: OC3
Applique type is Channelized Sonet
Clock Source is Internal
Medium info:
  Type: Sonet, Line Coding: NRZ,
  Alarm Throttling: OFF
SECTION:
  LOS = 1          LOP = 0          BIP(B1) = 0

```

#### SONET Section Tables

| INTERVAL    | CV-S | ES-S | SES-S | SEFS-S | PSC         |
|-------------|------|------|-------|--------|-------------|
| 12:15-12:29 | 0    | 0    | 0     | 0      | 0           |
| 12:00-12:15 | 0    | 0    | 0     | 0      | 0           |
| 11:45-12:00 | 0    | 0    | 0     | 0      | 0           |
| 11:30-11:45 | 0    | 404  | 404   | 404    | 1           |
| 11:15-11:30 | 0    | 619  | 619   | 619    | 1           |
| 11:00-11:15 | 0    | 0    | 0     | 0      | 0           |
| 10:45-11:00 | 0    | 711  | 711   | 711    | 0           |
| 10:30-10:45 | 0    | 656  | 656   | 656    | 0 (Invalid) |

Total of Data in Current and Previous Intervals

```

                                0    2390    2390    2390    2    (Invalid)

LINE:
  AIS = 0          RDI = 0          REI = 12          BIP(B2) = 36
Active Defects: None
Detected Alarms: None
Asserted/Active Alarms: None
Alarm reporting enabled for: SLOS SLOF LAIS SF SD LRDI B1-TCA B2-TCA
BER thresholds: SF = 10e-3 SD = 10e-6
TCA thresholds: B1 = 10e-6 B2 = 10e-6
Rx: S1S0 = NA
    K1 = 00,    K2 = 00
    J0 = 00

    RX S1 = 00

Tx: S1S0 = NA
    K1 = 00,    K2 = 00
    J0 = 04

Tx J0 Length : 64
Tx J0 Trace :

  52 6F 75 74 65 72 20 20 20 20 20 20 20 20 20 20 20 20 20 20 Router
  20 20 20 20 20 20 20 20 20 20 20 20 20 20 20 20 20 20 20 20
  20 20 20 20 20 20 20 20 20 20 20 20 20 20 20 20 20 20 20 20
  20 20 20 20 20 20 20 20 20 20 20 20 20 20 20 20 00 00 ..

Expected J0 Length : 64
Expected J0 Trace :

  52 6F 75 74 65 72 20 20 20 20 20 20 20 20 20 20 20 20 20 20 Router
  20 20 20 20 20 20 20 20 20 20 20 20 20 20 20 20 20 20 20 20
  20 20 20 20 20 20 20 20 20 20 20 20 20 20 20 20 20 20 20 20
  20 20 20 20 20 20 20 20 20 20 20 20 20 20 20 20 00 00 ..

Rx J0 Length : 64
Rx J0 Trace :

  52 6F 75 74 65 72 20 20 20 20 20 20 20 20 20 20 20 20 20 20 Router
  20 20 20 20 20 20 20 20 20 20 20 20 20 20 20 20 20 20 20 20
  20 20 20 20 20 20 20 20 20 20 20 20 20 20 20 20 20 20 20 20
  20 20 20 20 20 20 20 20 20 20 20 20 20 20 20 20 0D 00 ..

SONET Line Tables
INTERVAL    CV-L  ES-L  SES-L  UAS-L  CV-LFE  ES-LFE  SES-LFE  UAS-LFE
02:35-02:48    0    5    5    0    0    0    0    0    0 (NE, FE Invalid)

PATH 1:
Clock Source is internal

  AIS = 0          RDI = 0          REI = 0          BIP(B3) = 0
  LOM = 0          PLM = 0          UNEQ = 0         LOP = 0

Active Defects: None
Detected Alarms: None
Asserted/Active Alarms: None
Alarm reporting enabled for: PAIS PRDI PUNEQ PLOP PPLM LOM B3-SF B3-SD B3-TCA

BER threshold: SF = 10e-3 SD = 10e-6
TCA threshold: B3 = 10e-6
Rx: C2 = 00

```

Tx: C2 = 00

Tx J1 Length : 64

Tx J1 Trace

```

52 6F 75 74 65 72 20 30 2F 33 2F 31 2E 31 00 00 Router 0/3/1.1..
00 00 00 00 00 00 00 00 00 00 00 00 00 00 00 00 .....
00 00 00 00 00 00 00 00 00 00 00 00 00 00 00 00 .....
00 00 00 00 00 00 00 00 00 00 00 00 00 00 00 00 .....

```

Expected J1 Length : 64

Expected J1 Trace

```

52 6F 75 74 65 72 20 30 2F 33 2F 31 2E 31 00 00 Router 0/3/1.1..
00 00 00 00 00 00 00 00 00 00 00 00 00 00 00 00 .....
00 00 00 00 00 00 00 00 00 00 00 00 00 00 00 00 .....
00 00 00 00 00 00 00 00 00 00 00 00 00 00 00 00 .....

```

Rx J1 Length : 0

Rx J1 Trace

PATH 2:

Clock Source is internal

```

AIS = 0          RDI = 0          REI = 0          BIP(B3) = 0
LOM = 0          PLM = 0          UNEQ = 0         LOP = 0

```

Active Defects: None

Detected Alarms: None

Asserted/Active Alarms: None

Alarm reporting enabled for: PAIS PRDI PUNEQ PLOP PPLM LOM B3-SF B3-SD B3-TCA

BER threshold: SF = 10e-3 SD = 10e-6

TCA threshold: B3 = 10e-6

Rx: C2 = 00

Tx: C2 = 00

Tx J1 Length : 64

Tx J1 Trace

```

52 6F 75 74 65 72 20 30 2F 33 2F 31 2E 32 00 00 Router 0/3/1.2..
00 00 00 00 00 00 00 00 00 00 00 00 00 00 00 00 .....
00 00 00 00 00 00 00 00 00 00 00 00 00 00 00 00 .....
00 00 00 00 00 00 00 00 00 00 00 00 00 00 00 00 .....

```

Expected J1 Length : 64

Expected J1 Trace

```

52 6F 75 74 65 72 20 30 2F 33 2F 31 2E 32 00 00 Router 0/3/1.2..
00 00 00 00 00 00 00 00 00 00 00 00 00 00 00 00 .....
00 00 00 00 00 00 00 00 00 00 00 00 00 00 00 00 .....
00 00 00 00 00 00 00 00 00 00 00 00 00 00 00 00 .....

```

Rx J1 Length : 0

Rx J1 Trace

PATH 3:

Clock Source is internal

```

AIS = 0          RDI = 0          REI = 0          BIP(B3) = 0
LOM = 0          PLM = 0          UNEQ = 0         LOP = 0

```

```

Active Defects: None
Detected Alarms: None
Asserted/Active Alarms: None
Alarm reporting enabled for: PAIS PRDI PUNEQ PLOP PPLM LOM B3-SF B3-SD B3-TCA

BER threshold: SF = 10e-3 SD = 10e-6
TCA threshold: B3 = 10e-6
Rx: C2 = 00
Tx: C2 = 00

Tx J1 Length : 64
Tx J1 Trace

    52 6F 75 74 65 72 20 30 2F 33 2F 31 2E 33 00 00      Router 0/3/1.3..
    00 00 00 00 00 00 00 00 00 00 00 00 00 00 00 00      .....
    00 00 00 00 00 00 00 00 00 00 00 00 00 00 00 00      .....
    00 00 00 00 00 00 00 00 00 00 00 00 00 00 00 00      .....

Expected J1 Length : 64
Expected J1 Trace

    52 6F 75 74 65 72 20 30 2F 33 2F 31 2E 33 00 00      Router 0/3/1.3..
    00 00 00 00 00 00 00 00 00 00 00 00 00 00 00 00      .....
    00 00 00 00 00 00 00 00 00 00 00 00 00 00 00 00      .....
    00 00 00 00 00 00 00 00 00 00 00 00 00 00 00 00      .....

Rx J1 Length : 0
Rx J1 Trace

```

## Configuring Port Rate and Verifying Pluggables

A comprehensive range of pluggable optical modules is available. For more information, see *Cisco ASR 920 Series - Supported Optics*.

### Configuring Port Rate for SONET

To configure port rate for SONET, use the following commands:

```

enable
configure terminal
controller mediatype 0/0/16
mode sonet
exit
controller sonet 0/0/16
rate oc3

```

### Verifying the Pluggables

Before you configure the pluggables, use the following commands to verify the supported pluggables:

**show hw-module subslot <slot/bay> transceiver <port> status:**

```

The Transceiver in slot 0 subslot 7 port 4 is enabled.
Module temperature                = +46.636 C
Transceiver Tx supply voltage     = 3291.5 mVolts
Transceiver Tx bias current       = 17264 uAmps

```

```

Transceiver Tx power           = -2.9 dBm
Transceiver Rx optical power   = -7.4 dBm

```



**Note** The `show hw-module subslot <slot/bay> transceiver <port> status` displays as **Enabled** if the pluggables are supported and the command displays as **Disabled** if the pluggables are not supported.

**show hw-module subslot <slot/bay> transceiver <port> idprom:**

```

show hw-module subslot 0/7 transceiver 6 idprom detail
IDPROM for transceiver SPA-1T8S-10CS_7/6:
  Description                               = SFP or SFP+ optics (type 3)
  Transceiver Type:                         = ONS SE Z1 (406)
  Product Identifier (PID)                   = ONS-SE-Z1
  Vendor Revision                            = A
  Serial Number (SN)                        = FNS19251NPM
  Vendor Name                                = CISCO-FINISAR
  Vendor OUI (IEEE company ID)              = 00.90.65 (36965)
  CLEI code                                  = WMOTCZPAAA
  Cisco part number                          = 10-1971-04
  Device State                               = Enabled.
  Date code (yy/mm/dd)                      = 15/06/19
  Connector type                             = LC.
  Encoding                                   = 8B10B
                                           NRZ
                                           Manchester
  Nominal bitrate                            = OC48/STM16 (2500 Mbits/s)
  Minimum bit rate as % of nominal bit rate = not specified
  Maximum bit rate as % of nominal bit rate = not specified
  The transceiver type is 406
  Link reach for 9u fiber (km)               = IR-1 (15km) (15)
                                           = SR(2km) (0)
                                           IR-1 (15km) (0)
                                           IR-2 (40km) (0)
                                           LR-1 (40km) (0)
                                           LR-2 (80km) (0)
                                           LR-3 (80km) (0)
                                           DX (40KM) (0)
                                           HX (40km) (0)
                                           ZX (80km) (0)
                                           VX (100km) (0)
                                           1xFC, 2xFC-SM(10km) (0)
                                           ESCON-SM(20km) (0)
  Link reach for 50u fiber (m)              = SR(2km) (0)
                                           IR-1 (15km) (0)
                                           IR-2 (40km) (0)
                                           LR-1 (40km) (0)
                                           LR-2 (80km) (0)
                                           LR-3 (80km) (0)
                                           DX (40KM) (0)
                                           HX (40km) (0)
                                           ZX (80km) (0)
                                           VX (100km) (0)
                                           1xFC, 2xFC-SM(10km) (0)
                                           ESCON-SM(20km) (0)
  Nominal laser wavelength                   = 1310 nm.
  DWDM wavelength fraction                  = 1310.0 nm.
  Supported options                          = Tx disable
                                           Tx fault signal
                                           Loss of signal (standard implementation)
  Supported enhanced options                 = Alarms for monitored parameters
                                           Software Rx LOS monitoring

```

```

Diagnostic monitoring = Digital diagnostics supported
                    = Diagnostics are externally calibrated
                    = Rx power measured is "Average power"

Transceiver temperature operating range = -40 C to 85 C (industrial)
Minimum operating temperature = -40 C
Maximum operating temperature = 85 C
High temperature alarm threshold = +90.000 C
High temperature warning threshold = +85.000 C
Low temperature warning threshold = -40.000 C
Low temperature alarm threshold = -45.000 C
High voltage alarm threshold = 3630.0 mVolts
High voltage warning threshold = 3470.0 mVolts
Low voltage warning threshold = 3140.0 mVolts
Low voltage alarm threshold = 2971.2 mVolts
High laser bias current alarm threshold = 85.000 mAmps
High laser bias current warning threshold = 65.000 mAmps
Low laser bias current warning threshold = 4.000 mAmps
Low laser bias current alarm threshold = 2.000 mAmps
High transmit power alarm threshold = 4.0 dBm
High transmit power warning threshold = 2.0 dBm
Low transmit power warning threshold = -7.0 dBm
Low transmit power alarm threshold = -9.0 dBm
High receive power alarm threshold = 1.0 dBm
Low receive power alarm threshold = -26.0 dBm
High receive power warning threshold = -1.0 dBm
Low receive power warning threshold = -24.9 dBm
External Calibration: bias current slope = 1.000
External Calibration: bias current offset = 0

```

#### show hw-module subslot <slot/bay> transceiver <port> idprom brief:

```

sh hw-module subslot 0/7 transceiver 6 idprom brief
IDPROM for transceiver SPA-1T8S-10CS_7/6:
  Description = SFP or SFP+ optics (type 3)
  Transceiver Type: = ONS SE Z1 (406)
  Product Identifier (PID) = ONS-SE-Z1
  Vendor Revision = A
  Serial Number (SN) = FNS19251NQ0
  Vendor Name = CISCO-FINISAR
  Vendor OUI (IEEE company ID) = 00.90.65 (36965)
  CLEI code = WMOTCZPAAA
  Cisco part number = 10-1971-04
  Device State = Enabled.
  Date code (yy/mm/dd) = 15/06/19
  Connector type = LC.
  Encoding = 8B10B
              NRZ
              Manchester
  Nominal bitrate = OC48/STM16 (2500 Mbits/s)
  Minimum bit rate as % of nominal bit rate = not specified
  Maximum bit rate as % of nominal bit rate = not specified

```

## Loopback Remote on T1 and T3 Interfaces

The remote loopback configuration attempts to put the far-end T1 or T3 into a loopback.

The remote loopback setting loops back the far-end at line or payload, using IBOC (inband bit-orientated CDE) or the ESF loopback codes to communicate the request to the far-end.

## Restrictions for Loopback Remote

- E1 and E3 loopback remote are not supported until Cisco IOS XE Fuji 16.9.4 release. Starting from Cisco IOS XE Fuji 16.9.5 release, E1 and E3 loopback remote are supported.
- IBOC loopcode configuration is not supported when CESoP or SATOP (framed or unframed) is configured.
- ESF loopcode configuration is not supported when SAToP is configured.

## Configuring Loopback Remote in Sonet

To set T1 loopback remote iboc fac1/fac2/csu for OCX sonet, perform the following tasks in global configuration mode:

```
enable
configure terminal
controller sonet 0/0/1
mode ct3
t1 1 loopback remote iboc {fac1 | fac2 | csu}
mode vt-15
vtg 1 t1 1 loopback remote iboc {fac1 | fac2 | csu}
```

To set T1 loopback remote iboc esf line csu/esf payload for OCX sonet, perform the following tasks in global configuration mode:

```
enable
configure terminal
controller sonet 0/0/1
mode ct3
t1 1 loopback remote iboc esf {line csu | payload}
mode vt-15
vtg 1 t1 1 loopback remote esf {line csu | payload}
```

To set T3 loopback remote line/payload for OCX in sonet, perform the following tasks in global configuration mode:

```
enable
configure terminal
controller sonet 0/0/1
mode t3
t3 loopback remote {line | payload}
```



---

**Note** loopback remote esf line niu is not supported.

---

## Verifying the Loopback Remote Configuration

Use the following command to check the T1 loopback remote configuration:

```
router# show run | sec 0/0/1
controller SONET 0/0/1
rate OC3
no ais-shut
alarm-report all
```



```

clock source internal
!
sts-1 1
!
sts-1 2
  clock source internal
  mode ct3
  t3 framing c-bit
  t3 clock source internal
  t1 1 Loopback remote iboc fac1
  t1 1 framing SF

```

Use the following command to verify the T1 loopback remote configuration:

```

Router(config-ctrlr-sts1)# show controller sonet 0/0/1 | b STS-1 2, T1 1
STS-1 2, T1 1 (CT3 2-1) is up
  timeslots:
    Configured for NIU FAC1 Line Loopback with IBOC
    Currently in Inband Remotely Line Looped
  Receiver has no alarms.
  Framing is SF, Clock Source is Internal

```

Use the following command to check T3 loopback remote configuration:

```

Router# show run | sec 0/0/1
controller SONET 0/0/1
rate OC3
no ais-shut
alarm-report all
clock source internal
!
sts-1 1
!
sts-1 2
!
sts-1 3
  clock source internal
  mode t3
  t3 framing c-bit
  t3 loop remote line
  t3 clock source internal

```

Use the following command to verify T3 loopback remote configuration:

```

Router(config-ctrlr-sts1)# do show controller sonet 0/0/1 | b Path 3
OC3.STS1 0/0/1 Path 3 is up. (Configured for Remotely Looped)
  Currently in Remotely Line Looped
  Hardware is

  Applique type is T3
  Receiver has no alarms.
  MDL transmission is disabled

```

## Associated Commands

The following table shows the Associated Commands for SONET configuration:

| Commands  | Links   |
|---|---|
| <b>ais-shut</b>                                     | <a href="http://www.cisco.com/c/en/us/td/docs/ios-xml/ios/interface/command/ir-cr-book/ir-a1.html#wp7654966010">http://www.cisco.com/c/en/us/td/docs/ios-xml/ios/interface/command/ir-cr-book/ir-a1.html#wp7654966010</a> |
| <b>alarm-report</b>                                 | <a href="http://www.cisco.com/c/en/us/td/docs/ios-xml/ios/interface/command/ir-cr-book/ir-a1.html#wp2800999060">http://www.cisco.com/c/en/us/td/docs/ios-xml/ios/interface/command/ir-cr-book/ir-a1.html#wp2800999060</a> |
| <b>aps adm</b>                                      | <a href="http://www.cisco.com/c/en/us/td/docs/ios-xml/ios/interface/command/ir-cr-book/ir-a1.html#wp8015117230">http://www.cisco.com/c/en/us/td/docs/ios-xml/ios/interface/command/ir-cr-book/ir-a1.html#wp8015117230</a> |
| <b>aps group</b>                                    | <a href="http://www.cisco.com/c/en/us/td/docs/ios-xml/ios/interface/command/ir-cr-book/ir-a1.html#wp1674734739">http://www.cisco.com/c/en/us/td/docs/ios-xml/ios/interface/command/ir-cr-book/ir-a1.html#wp1674734739</a> |
| <b>aps protect</b>                                  | <a href="http://www.cisco.com/c/en/us/td/docs/ios-xml/ios/interface/command/ir-cr-book/ir-a1.html#wp2073867702">http://www.cisco.com/c/en/us/td/docs/ios-xml/ios/interface/command/ir-cr-book/ir-a1.html#wp2073867702</a> |
| <b>aps revert</b>                                   | <a href="http://www.cisco.com/c/en/us/td/docs/ios-xml/ios/interface/command/ir-cr-book/ir-a1.html#wp4063780600">http://www.cisco.com/c/en/us/td/docs/ios-xml/ios/interface/command/ir-cr-book/ir-a1.html#wp4063780600</a> |
| <b>aps unidirectional</b>                           | <a href="http://www.cisco.com/c/en/us/td/docs/ios-xml/ios/interface/command/ir-cr-book/ir-a1.html#wp5340799170">http://www.cisco.com/c/en/us/td/docs/ios-xml/ios/interface/command/ir-cr-book/ir-a1.html#wp5340799170</a> |
| <b>aps working</b>                                  | <a href="http://www.cisco.com/c/en/us/td/docs/ios-xml/ios/interface/command/ir-cr-book/ir-a1.html#wp8949584630">http://www.cisco.com/c/en/us/td/docs/ios-xml/ios/interface/command/ir-cr-book/ir-a1.html#wp8949584630</a> |
| <b>cem-group</b> <i>cem-group-number</i> <b>cep</b> | <a href="http://www.cisco.com/c/en/us/td/docs/ios-xml/ios/interface/command/ir-cr-book/ir-c1.html#wp2440628600">http://www.cisco.com/c/en/us/td/docs/ios-xml/ios/interface/command/ir-cr-book/ir-c1.html#wp2440628600</a> |
| <b>controller mediatype</b>                         | <a href="http://www.cisco.com/c/en/us/td/docs/ios-xml/ios/interface/command/ir-cr-book/ir-c2.html#wp1201337639">http://www.cisco.com/c/en/us/td/docs/ios-xml/ios/interface/command/ir-cr-book/ir-c2.html#wp1201337639</a> |
| <b>controller protection-group</b>                  | <a href="http://www.cisco.com/c/en/us/td/docs/ios-xml/ios/mcl/allreleasemcl/all-book/all-03.html">http://www.cisco.com/c/en/us/td/docs/ios-xml/ios/mcl/allreleasemcl/all-book/all-03.html</a>                             |
| <b>controller sonet</b>                             | <a href="http://www.cisco.com/c/en/us/td/docs/ios-xml/ios/interface/command/ir-cr-book/ir-c2.html#wp2020468554">http://www.cisco.com/c/en/us/td/docs/ios-xml/ios/interface/command/ir-cr-book/ir-c2.html#wp2020468554</a> |
| <b>clock source</b>                                 | <a href="http://www.cisco.com/c/en/us/td/docs/ios-xml/ios/interface/command/ir-cr-book/ir-c2.html#wp3604380959">http://www.cisco.com/c/en/us/td/docs/ios-xml/ios/interface/command/ir-cr-book/ir-c2.html#wp3604380959</a> |
| <b>loopback</b>                                     | <a href="http://www.cisco.com/c/en/us/td/docs/ios-xml/ios/interface/command/ir-cr-book/ir-l2.html#wp2735045490">http://www.cisco.com/c/en/us/td/docs/ios-xml/ios/interface/command/ir-cr-book/ir-l2.html#wp2735045490</a> |

| Commands                                    | Links   |
|---|---|
| <b>mode sonet</b>                           | <a href="http://www.cisco.com/c/en/us/td/docs/ios-xml/ios/interface/command/ir-cr-book/ir-l2.html#wp2327088950">http://www.cisco.com/c/en/us/td/docs/ios-xml/ios/interface/command/ir-cr-book/ir-l2.html#wp2327088950</a> |
| <b>mode sts-nc</b>                          | <a href="http://www.cisco.com/c/en/us/td/docs/ios-xml/ios/interface/command/ir-cr-book/ir-l2.html#wp1791424945">http://www.cisco.com/c/en/us/td/docs/ios-xml/ios/interface/command/ir-cr-book/ir-l2.html#wp1791424945</a> |
| <b>mode vt-15</b>                           | <a href="http://www.cisco.com/c/en/us/td/docs/ios-xml/ios/interface/command/ir-cr-book/ir-l2.html#wp1137973905">http://www.cisco.com/c/en/us/td/docs/ios-xml/ios/interface/command/ir-cr-book/ir-l2.html#wp1137973905</a> |
| <b>overhead c2</b>                          | <a href="http://www.cisco.com/c/en/us/td/docs/ios-xml/ios/interface/command/ir-cr-book/ir-o1.html#wp1973678817">http://www.cisco.com/c/en/us/td/docs/ios-xml/ios/interface/command/ir-cr-book/ir-o1.html#wp1973678817</a> |
| <b>overhead j0</b>                          | <a href="http://www.cisco.com/c/en/us/td/docs/ios-xml/ios/interface/command/ir-cr-book/ir-o1.html#wp4338698890">http://www.cisco.com/c/en/us/td/docs/ios-xml/ios/interface/command/ir-cr-book/ir-o1.html#wp4338698890</a> |
| <b>overhead j1</b>                          | <a href="http://www.cisco.com/c/en/us/td/docs/ios-xml/ios/interface/command/ir-cr-book/ir-o1.html#wp1987243836">http://www.cisco.com/c/en/us/td/docs/ios-xml/ios/interface/command/ir-cr-book/ir-o1.html#wp1987243836</a> |
| <b>overhead s1s0</b>                        | <a href="http://www.cisco.com/c/en/us/td/docs/ios-xml/ios/interface/command/ir-cr-book/ir-o1.html#wp2779929239">http://www.cisco.com/c/en/us/td/docs/ios-xml/ios/interface/command/ir-cr-book/ir-o1.html#wp2779929239</a> |
| <b>protection-group</b>                     | <a href="http://www.cisco.com/c/en/us/td/docs/ios-xml/ios/mcl/allreleasemcl/all-book/all-10.html">http://www.cisco.com/c/en/us/td/docs/ios-xml/ios/mcl/allreleasemcl/all-book/all-10.html</a>                             |
| <b>protection-group [working   protect]</b> | <a href="http://www.cisco.com/c/en/us/td/docs/ios-xml/ios/mcl/allreleasemcl/all-book/all-10.html">http://www.cisco.com/c/en/us/td/docs/ios-xml/ios/mcl/allreleasemcl/all-book/all-10.html</a>                             |
| <b>rate [OC3   OC12   OC48   OC192]</b>     | <a href="http://www.cisco.com/c/en/us/td/docs/ios-xml/ios/interface/command/ir-cr-book/ir-o1.html#wp4442889730">http://www.cisco.com/c/en/us/td/docs/ios-xml/ios/interface/command/ir-cr-book/ir-o1.html#wp4442889730</a> |
| <b>shutdown</b>                             | <a href="http://www.cisco.com/c/en/us/td/docs/ios-xml/ios/interface/command/ir-cr-book/ir-s6.html#wp3364503641">http://www.cisco.com/c/en/us/td/docs/ios-xml/ios/interface/command/ir-cr-book/ir-s6.html#wp3364503641</a> |
| <b>show controllers sonet</b>               | <a href="http://www.cisco.com/c/en/us/td/docs/ios-xml/ios/interface/command/ir-cr-book/ir-s3.html#wp1341372847">http://www.cisco.com/c/en/us/td/docs/ios-xml/ios/interface/command/ir-cr-book/ir-s3.html#wp1341372847</a> |
| <b>show hw-module subslot transceiver</b>   | <a href="http://www.cisco.com/c/en/us/td/docs/ios-xml/ios/interface/command/ir-cr-book/ir-s4.html#wp6553420000">http://www.cisco.com/c/en/us/td/docs/ios-xml/ios/interface/command/ir-cr-book/ir-s4.html#wp6553420000</a> |
| <b>show protection-group</b>                | <a href="http://www.cisco.com/c/en/us/td/docs/ios-xml/ios/mcl/allreleasemcl/all-book/all-14.html">http://www.cisco.com/c/en/us/td/docs/ios-xml/ios/mcl/allreleasemcl/all-book/all-14.html</a>                             |
| <b>sts-1</b>                                | <a href="http://www.cisco.com/c/en/us/td/docs/ios-xml/ios/interface/command/ir-cr-book/ir-s6.html#wp2423232697">http://www.cisco.com/c/en/us/td/docs/ios-xml/ios/interface/command/ir-cr-book/ir-s6.html#wp2423232697</a> |

| Commands   | Links   |
|--|---|
| <b>t1</b> <i>t1-line-number framing</i>                      | <a href="http://www.cisco.com/c/en/us/td/docs/ios-xml/ios/interface/command/ir-cr-book/ir-t1.html#wp2623191253">http://www.cisco.com/c/en/us/td/docs/ios-xml/ios/interface/command/ir-cr-book/ir-t1.html#wp2623191253</a> |
| <b>t1</b> <i>t1-line-number clock source</i>                 | <a href="http://www.cisco.com/c/en/us/td/docs/ios-xml/ios/interface/command/ir-cr-book/ir-t1.html#wp3480850667">http://www.cisco.com/c/en/us/td/docs/ios-xml/ios/interface/command/ir-cr-book/ir-t1.html#wp3480850667</a> |
| <b>threshold</b>   | <a href="http://www.cisco.com/c/en/us/td/docs/ios-xml/ios/interface/command/ir-cr-book/ir-t1.html#wp2311589330">http://www.cisco.com/c/en/us/td/docs/ios-xml/ios/interface/command/ir-cr-book/ir-t1.html#wp2311589330</a> |
| <b>type sts48c</b>   | <a href="http://www.cisco.com/c/en/us/td/docs/ios-xml/ios/mcl/allreleasemcl/all-book/all-15.html">http://www.cisco.com/c/en/us/td/docs/ios-xml/ios/mcl/allreleasemcl/all-book/all-15.html</a>                             |
| <b>vtg</b> <i>vtg-line-number t1 t1-line-number loopback</i> | <a href="http://www.cisco.com/c/en/us/td/docs/ios-xml/ios/interface/command/ir-cr-book/ir-t2.html#wp3494199143">http://www.cisco.com/c/en/us/td/docs/ios-xml/ios/interface/command/ir-cr-book/ir-t2.html#wp3494199143</a> |