



Cisco Routed Optical Networking Solution Guide, Release 1.0

First Published: 2021-07-05

Last Modified: 2021-11-30

Americas Headquarters

Cisco Systems, Inc.
170 West Tasman Drive
San Jose, CA 95134-1706
USA
<http://www.cisco.com>
Tel: 408 526-4000
800 553-NETS (6387)
Fax: 408 527-0883

THE SPECIFICATIONS AND INFORMATION REGARDING THE PRODUCTS IN THIS MANUAL ARE SUBJECT TO CHANGE WITHOUT NOTICE. ALL STATEMENTS, INFORMATION, AND RECOMMENDATIONS IN THIS MANUAL ARE BELIEVED TO BE ACCURATE BUT ARE PRESENTED WITHOUT WARRANTY OF ANY KIND, EXPRESS OR IMPLIED. USERS MUST TAKE FULL RESPONSIBILITY FOR THEIR APPLICATION OF ANY PRODUCTS.

THE SOFTWARE LICENSE AND LIMITED WARRANTY FOR THE ACCOMPANYING PRODUCT ARE SET FORTH IN THE INFORMATION PACKET THAT SHIPPED WITH THE PRODUCT AND ARE INCORPORATED HEREIN BY THIS REFERENCE. IF YOU ARE UNABLE TO LOCATE THE SOFTWARE LICENSE OR LIMITED WARRANTY, CONTACT YOUR CISCO REPRESENTATIVE FOR A COPY.

The Cisco implementation of TCP header compression is an adaptation of a program developed by the University of California, Berkeley (UCB) as part of UCB's public domain version of the UNIX operating system. All rights reserved. Copyright © 1981, Regents of the University of California.

NOTWITHSTANDING ANY OTHER WARRANTY HEREIN, ALL DOCUMENT FILES AND SOFTWARE OF THESE SUPPLIERS ARE PROVIDED "AS IS" WITH ALL FAULTS. CISCO AND THE ABOVE-NAMED SUPPLIERS DISCLAIM ALL WARRANTIES, EXPRESSED OR IMPLIED, INCLUDING, WITHOUT LIMITATION, THOSE OF MERCHANTABILITY, FITNESS FOR A PARTICULAR PURPOSE AND NON-INFRINGEMENT OR ARISING FROM A COURSE OF DEALING, USAGE, OR TRADE PRACTICE.

IN NO EVENT SHALL CISCO OR ITS SUPPLIERS BE LIABLE FOR ANY INDIRECT, SPECIAL, CONSEQUENTIAL, OR INCIDENTAL DAMAGES, INCLUDING, WITHOUT LIMITATION, LOST PROFITS OR LOSS OR DAMAGE TO DATA ARISING OUT OF THE USE OR INABILITY TO USE THIS MANUAL, EVEN IF CISCO OR ITS SUPPLIERS HAVE BEEN ADVISED OF THE POSSIBILITY OF SUCH DAMAGES.

Any Internet Protocol (IP) addresses and phone numbers used in this document are not intended to be actual addresses and phone numbers. Any examples, command display output, network topology diagrams, and other figures included in the document are shown for illustrative purposes only. Any use of actual IP addresses or phone numbers in illustrative content is unintentional and coincidental.

All printed copies and duplicate soft copies of this document are considered uncontrolled. See the current online version for the latest version.

Cisco has more than 200 offices worldwide. Addresses and phone numbers are listed on the Cisco website at www.cisco.com/go/offices.

Cisco and the Cisco logo are trademarks or registered trademarks of Cisco and/or its affiliates in the U.S. and other countries. To view a list of Cisco trademarks, go to this URL: <https://www.cisco.com/c/en/us/about/legal/trademarks.html>. Third-party trademarks mentioned are the property of their respective owners. The use of the word partner does not imply a partnership relationship between Cisco and any other company. (1721R)

© 2021 Cisco Systems, Inc. All rights reserved.



CONTENTS

CHAPTER 1	Introduction to Traditional Networks	1
	Business Challenge	1
	Traditional Multilayer Network Architectures	1
	Network Building Blocks	2
	Challenges with Current IP and Optical Networks	4

CHAPTER 2	Routed Optical Networking	5
	Routed Optical Networking Overview	5
	Routed Optical Networking Strategy	6
	Technology Overview	7
	Benefits of Routed Optical Networking	8
	Routed Optical Networking Deployment Models	9

CHAPTER 3	Routed Optical Networking Solution Components	11
	Hardware Components	11
	Cisco 8000 Series Routers	12
	Cisco Network Convergence System 5500 Series	13
	400G ZR/ZR+ Transceivers	14
	Device Supported Software	15
	Cisco Network Convergence System 2000 Series	15
	Network Planning Components	18
	Cisco WAN Automation Engine	18
	Cisco Optical Network Planner	19
	Automation Components	19
	Cisco Crosswork Hierarchical Controller	21
	Cisco Crosswork Network Controller	21

- Cisco Optical Network Controller 24
- Cisco Network Services Orchestrator 24
 - Cisco NSO Routed Optical Networking Core Function Pack 24
- Cisco Evolved Programmable Network Manager 26
- Routed Optical Networking Components Software Versions 27
- IOS-XR Software Components 27
 - Network Configuration (NETCONF) Protocol 27
 - Yet Another Next Generation Data Modeling Language 27
 - Model Driven Telemetry 28

CHAPTER 4 **Deployment Topologies 29**

- Metro/Regional Topology 29
- Mesh Topology 32
- Long Haul Topology 36

CHAPTER 5 **Automation Workflows 41**

- Sequence for Installation of Routed Optical Networking Components 41
- Communication Sequence 42
- Service Provisioning Examples 44
- Crosswork Hierarchical Controller Provisioning Workflow 49
- Troubleshoot Provisioning Issues 49

APPENDIX A **Sample End-to-end Configuration 55**



CHAPTER 1

Introduction to Traditional Networks

This chapter provides insight into the business challenge, components of a network, and the current challenges faced by IP and optical networks.

- [Business Challenge, on page 1](#)
- [Traditional Multilayer Network Architectures, on page 1](#)
- [Network Building Blocks, on page 2](#)
- [Challenges with Current IP and Optical Networks, on page 4](#)

Business Challenge

Today's networks, such as optical and packet networks, consist of multiple layers which are stitched together from many domains and vendors. Provisioning services in such complex environments requires intricate coordination between different management systems and organizations. It is challenging to operate these networks and the total cost of ownership (TCO) is rising. Service providers must simplify and reimagine the architecture to curtail the rising operational costs and fast-track the delivery of new services.

Solution

The Routed Optical Networking solution aims to simplify networks by removing the complexities inherent to the infrastructure. This simplification allows service providers to leverage their assets more effectively by:

- unifying the IP and optical layers of the network using a single control plane
- using high-speed coherent pluggable modules that offer reach and performance at appropriate cost points and power profiles
- simplifying the network life-cycle management by leveraging automation in all phases of the lifecycle

Changing the paradigm, the Cisco Routed Optical Networking solution improves operational efficiency and reduces network TCO. The transformed network also increases service agility.

Traditional Multilayer Network Architectures

Traditional network infrastructure consists of an IP layer and an optical transport layer. The optical layer consists of a Dense Wavelength Division Multiplexing (DWDM) layer, and optionally an Optical Transport Network (OTN) switching layer. Each layer has its own independent control and management planes.

A distributed control plane communicates network information between network elements to enable end-to-end communication between network clients. Distributing routing information is the responsibility of the IP control plane. Resource and connection management between optical endpoints is the responsibility of the optical control plane.

The following table lists network layers and their corresponding control planes:

Layer	Control Plane
Packet layer/IP layer	BGP, IGP, Segment routing
Optical Transport Network layer	ASON/GMPLS
Dense Wavelength Division Multiplexing layer	WSO/SSO

Figure 1: Traditional Network Architecture

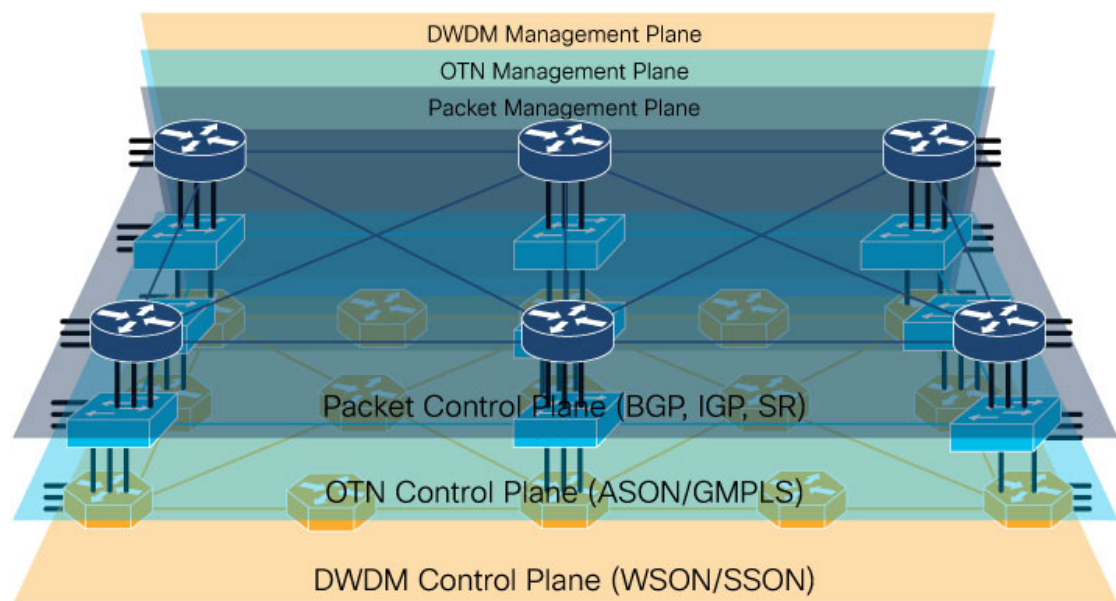

Each layer operates independently with separate redundancy and life cycles. Logically different teams are necessary to establish and maintain each layer.

Network Building Blocks

Traditional hierarchical networks consists of an IP layer and an optical transport layer.

IP Layer

The IP layer is responsible for creating and maintaining the routing table and forwarding packets according to the routing table. The IP layer of traditional networks consists of interconnected routers.

Routers are the building blocks of packet networks and are responsible for efficiently forwarding IP or MPLS packets. Routers are used to create any to any fabrics used to carry virtually all networking traffic today, including the global Internet. Routers are also responsible for providing different functions based on their role in the network. Two examples are core and Provider Edge routers. Core routers use a simplified set of

implemented features and supply high capacity interconnect between different regions in a network. Provider Edge (PE) routers support high scale overlay VPN services.

Optical Layer

The following diagram shows a typical DWDM network:

Figure 2: Typical DWDM Network

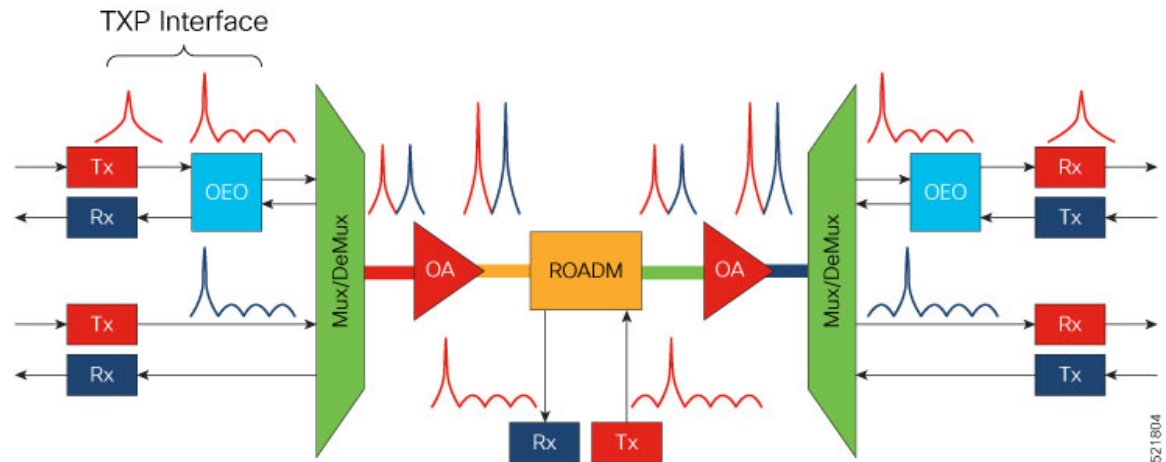

This table lists the abbreviations in the preceding image and their expansions:

TXP	Transponder
OEO	Optical-electrical-optical
Mux	Multiplexer
DeMux	Demultiplexer
OA	Optical amplifier
ROADM	Reconfigurable optical add/drop multiplexer

The building blocks of a typical DWDM network are:

- **Optical Transmitters and Receivers:** Transmitters provide source signals. They convert digital electrical signals into a light stream of a specific wavelength. Optical receivers detect pulses of light on optical fibers and convert optical signals to electrical signals.
- **Transponders:** Transponders take signals on gray wavelengths and send them in colored wavelengths. Colored wavelengths are wavelengths in the WDM standard. Gray wavelengths are wavelengths not in the WDM standard. A bidirectional transponder also receives a WDM standard bit-stream and converts the signals back to the wavelength used by the client device.
- **Muxponders:** Muxponders are similar to transponders. Muxponders take multiple gray wavelength signals and send them in a single colored-wavelength using Time Division Multiplexing (TDM).
- **Multiplexers/Demultiplexers:** Multiplexers take multiple wavelengths on separate fibers and combine them into a single fiber. The output of a multiplexer is a composite signal. Demultiplexers take composite

signals that compatible multiplexers generate and separate the individual wavelengths into individual fibers.

- **Optical Amplifiers:** Optical amplifiers amplify an optical signal. Optical amplifiers increase the total power of the optical signal to enable the signal transmission across longer distances. Without amplifiers, the signal attenuation over longer distances makes it impossible to coherently receive signals. We use different types of optical amplifiers in optical networks. For example: preamplifiers, booster amplifiers, inline amplifiers, and optical line amplifiers.
- **Optical add/drop multiplexers (OADMs):** OADMs are devices capable of adding one or more DWDM channels into or dropping them from a fiber.
- **Reconfigurable optical add/drop multiplexers (ROADMs):** ROADMs are programmable versions of OADMs. With ROADMs, you can change the wavelengths that are added or dropped. ROADMs make optical networks flexible and easily modifiable.

Challenges with Current IP and Optical Networks

Current hierarchical service provider networks have up to three different layers, IP, OTN, and DWDM, each with separate control planes. These networks have a layered and siloed architecture relying on dedicated hardware to exchange traffic between layers. The siloed architecture also often results in separate opaque redundancy mechanisms at each layer, increasing complexity and reducing overall network efficiency. The large number of devices used to interconnect the layers increases power utilization and drives up the overall carbon footprint of the network.

The layered and siloed architecture warrants manual service-stitching across network domains. The necessity for manual intervention hinders end-to-end automation and results in higher time to resolution and loss of efficiency.

Traffic runs over too many elements. The need for separate management of these elements by different departments and the lack of automated management increases the complexity and cost of the network.

Current service provider networks have immense complexities and face challenges in:

- Network planning
- Provisioning
- Path and network optimization
- Network monitoring
- Fault correction

These complexities and overlapping redundancies present bottlenecks to scaling the service provider networks efficiently.



CHAPTER 2

Routed Optical Networking

This chapter provides an overview of Routed Optical Networking, its benefits, and supported deployment models.

- [Routed Optical Networking Overview, on page 5](#)
- [Routed Optical Networking Strategy, on page 6](#)
- [Technology Overview, on page 7](#)
- [Benefits of Routed Optical Networking, on page 8](#)
- [Routed Optical Networking Deployment Models, on page 9](#)

Routed Optical Networking Overview

Routed Optical Networking simplifies complex multilayer networks by collapsing network layers and minimizing the functional overlap. Routed Optical Networking also improves the overall network efficiency by optimizing each layer of the network. The architecture also integrates open data models and standard APIs, enriching powerful automation making Routed Optical Networking easier to operate than legacy networks.

Routed Optical Networking is able to provide improvements and simplification because it:

- Leverages state of the art optical and routing technologies to converge services over an IP infrastructure connected by a simplified DWDM layer
- Simplifies end-to-end network architecture
- Utilizes a modern software stack that spans across network management and control planes
- Improves the capacity and cost efficiency of networks
- Has a smaller carbon footprint
- Offers unified capacity planning, unified EMS, unified path optimization, orchestration, and assurance
- Provides an automation ecosystem with open, programmable, and modular components
- Total Cost of Ownership savings across CapEx and OpEx

Routed Optical Networking utilizes high-density routers, high-capacity ZR or ZR+ pluggable digital coherent optics, simplified DWDM line systems, and end-to-end multi-layer automation to create next generation networks.

Routed Optical Networking Strategy

Routed Optical Networking architecture unifies the WDM, OTN, and packet transport layers into a single, easy-to-control layer.

Figure 3: Routed Optical Networking Strategy

A Converged SDN Transport architecture simplifies the network by converging services on a unified, automated infrastructure for maximum scalability and agility to support emerging services for the 5G era and beyond. See [Converged SDN Transport](#).

Routed Optical Networking as part of Cisco's Converged SDN Transport architecture brings network simplification to the physical network infrastructure, just as EVPN and Segment Routing simplify the service and traffic engineering network layers. Routed Optical Networking collapses complex technologies and network layers into a more cost efficient and easy to manage network infrastructure.

Routed Optical Networking achieves this architecture by leveraging high-density routers, high-capacity digital coherent pluggable optical modules, simplified optical elements, and advanced automation capabilities. Components of Routed Optical Network are also fully compliant ROADM-based networks and can interoperate seamlessly with a mix of traditional transponders and Routed Optical Networking DCO pluggables.

The converged architecture enables:

- Unified planning and design
- Seamless multi-layer provisioning
- Unified multi-layer management
- End-to-end multi-layer and multi-domain network visibility

The following table compares the legacy multilayered architecture and the Routed Optical Networking architecture.

Layered Architecture	Routed Optical Networking Architecture
Trades off port density and capacity on router line cards for coherent optical transmission	Higher port density and capacity on the router line cards using digital coherent pluggable optical modules
Proprietary components; noninteroperable	Standards-based approach; interoperable across vendors
Siloed approach; separate control and management planes	Common control and management planes for converged optical and IP layer
Manual service stitching necessary across network domains	Enables end-to-end closed-loop automation and manageability
Independent capacity planning on IP and optical layers, where additional capacity is dimensioned on each layer separately leading to CapEx inefficiencies.	Unified capacity planning on a converged network optimizing CapEx investments

Technology Overview

The following diagram displays the current multilayer architecture.

Figure 4: Multilayer Architecture

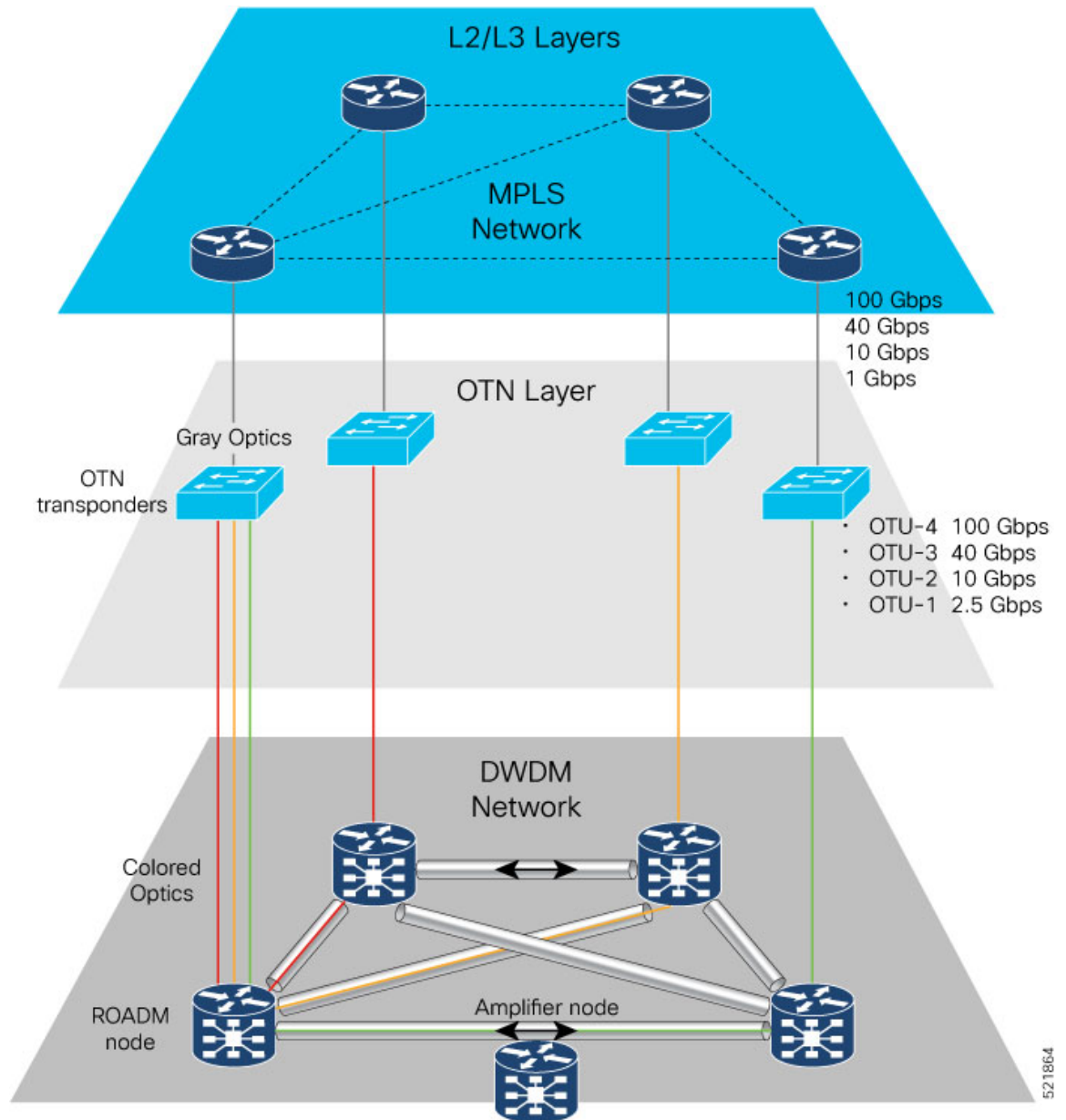

Routed Optical Networking is a transformative architecture that disrupts the existing multilayer network architecture. It converges all network services into a single layer.

The routers are connected over either dark fiber or a DWDM network with standardized pluggable digital coherent optics, such as ZR and ZR+ transceivers. These transceivers reduce cabling, power consumption, and physical footprint requirements versus using traditional external transponders.

The routers are connected with standardized pluggable coherent optics, such as ZR/ZR+ transceivers. These transceivers reduce cabling, power consumption, and footprint requirements.

With a single service layer based on IP, flexible management tools can leverage telemetry and model-driven programmability to streamline lifecycle operations. This simplified architecture integrates open data models and standard APIs, enabling a provider to focus on automation initiatives for a simpler topology.

The following diagram displays the Routed Optical Networking architecture.

Figure 5: Routed Optical Networking Architecture

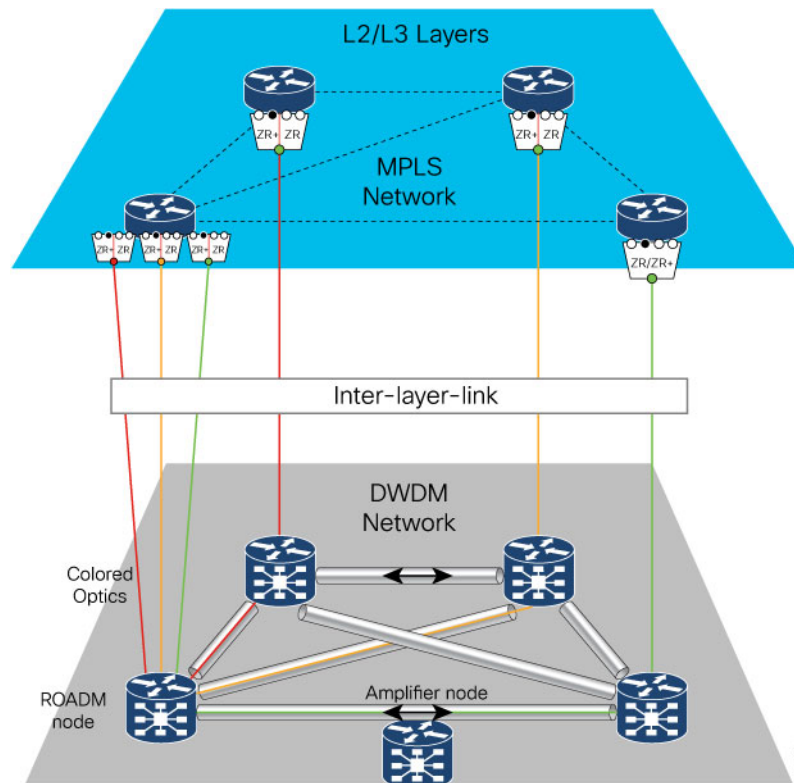

Benefits of Routed Optical Networking

The benefits of Routed Optical Networking are:

- Cost Savings:** Routed Optical Networking provides a decreased network total cost of ownership. Routed Optical networks make the most efficient use of high capacity routers and DWDM optical infrastructure. Utilizing the routers high capacity switching allows denser interconnection and the ability to move all traffic protection to the IP layer of the network. Routed Optical Networking saves costs by converging service layers, moving to a simplified DWDM optical system, and using industry standard ZR/ZR+ pluggable digital coherent optics. Elimination of multiple layers reduces power usage and hardware footprint. End-to-end multi-layer automation enables better utilization of network capacity.
- Simplification:** Using Converged SDN Transport technologies such as Segment Routing and EVPN along with the Routed Optical Networking simplifies networks from the base infrastructure layer to the services layer. Using Circuit-Style Segment Routing and Private Line Emulation, Routed Optical Networking allows providers to converge services while maintaining or exceeding current private line

service SLAs. This convergence leads to simplified planning, design, activation, management, and troubleshooting.

- **Automation:** Automation improves resiliency, failure detection, and ease of repair. Enhanced multi-layer visibility and root cause analysis allows network operators to quickly discover and remediate faults. Troubleshooting is enhanced with rich network telemetry at each layer.
- **Optimize Capacity:** Routed Optical Networking takes advantage of the IP layer's ability to statistical multiplex network traffic at the packet level. Statistical multiplexing is the most efficient way to carry network traffic with the ability to adapt to instantaneous traffic demands and avoid idle link capacity. Routed Optical Networking networks utilize fiber capacity to its fullest by intelligently utilizing capacity at the IP layer instead of wasting DWDM resources with unnecessary bypass circuits.

Routed Optical Networking Deployment Models

There is no one-size-fits-all solution for deploying a new architecture. The approach depends on the structure of the network and the goals of its owner. Thus, it is critical to have a flexible control platform that supports a phased deployment and a smooth evolution. The models are:

- **Routed Optical Networking Deployment:** When a new IP and optical network is deployed, the hardware, together with its control architecture – including Crosswork Hierarchical Controller, Crosswork Network Controller, and Cisco Optical Network Controller, is installed from scratch. In fact, it may be useful to install Crosswork Hierarchical Controller ahead of time, in preparation for the Routed Optical Networking deployment, over existing parts of the network, to help plan out the Routed Optical Networking network based on accurate data about the existing services, network, and fiber assets. See [Automation Components, on page 19](#). Cisco Networks managed using Cisco EPNM can utilize EPNM to manage Routed Optical Networking
- **Third-party Optical Network Routed Optical Networking Deployment:** When routers with ZR/ZR+ optics are deployed over networks that use third-party optical devices, Crosswork Hierarchical Controller is integrated with Crosswork Network Controller and the existing DWDM optical controllers. Crosswork Hierarchical Controller creates IP links between the routers by configuring the optical path through the optical controllers and terminates those paths on the DWDM transceivers in the routers.



CHAPTER 3

Routed Optical Networking Solution Components

This chapter describes the Routed Optical Networking solution components.

- [Hardware Components, on page 11](#)
- [Network Planning Components, on page 18](#)
- [Automation Components, on page 19](#)
- [IOS-XR Software Components, on page 27](#)

Hardware Components

The hardware components that enable Routed Optical Networking are:

- High Density Routers
 - [Cisco 8000 Series Routers](#)
 - [Cisco 8200 Series Routers, on page 12](#)
 - [Cisco 8800 Series Routers, on page 13](#)
 - [Cisco 8800 Series Line Cards, on page 13](#)
 - [Cisco Network Convergence System 5500 Series](#)
 - [Cisco NCS-57B1 Series Fixed Port Routers, on page 13](#)
 - [Cisco NCS 5500 Modular Chassis, on page 14](#)
 - [NCS 5700 Series Line Cards, on page 14](#)
- High Capacity Pluggable Optical Modules
 - [400G ZR/ZR+ Transceivers](#)
- Optical Line Systems
 - [Cisco Network Convergence System 2000 Series, on page 15](#)
 - [Cisco NCS 2006 Shelf, on page 15](#)
 - [Control Cards, on page 16](#)

- [ROADM Cards, on page 16](#)
- [Amplifier Cards, on page 16](#)
 - [EDFA Cards, on page 17](#)
 - [EDRA Cards, on page 17](#)
 - [Raman Amplifier Cards, on page 17](#)
- [Passive Multiplexer and Demultiplexer Module, on page 18](#)
- [Passive Patch Panel Modules, on page 18](#)
 - [MPO-16 to 16-LC Fan-Out Module, on page 18](#)

Cisco 8000 Series Routers

The Cisco 8000 series routers utilize Cisco's Silicon One ASIC to deliver full routing functionality at higher capacities and a lower environmental footprint than any other routing silicon available. The Silicon One architecture supports large forwarding tables, deep buffers, flexible packet operations, and enhanced programmability.

The 8000 series are highly scalable, deep-buffered, 100G/400G/800G optimized routers. They are also available with additional on-chip High Bandwidth Memory (HBM) to support additional resource scale. The Cisco 8000 series routers support both ZR and ZR+ modules.

Cisco 8200 Series Routers

The Cisco 8200 Series uses a single Cisco Silicon One ASIC to deliver full routing functionality. The Cisco 8200 Series is designed for relatively high-buffer and high-scale use cases. These fixed port, high-density routers provide 10.8 Tbps of network bandwidth with dramatically lower power consumption than contemporary 10 Tbps systems.

This table details the specifications of the routers.

Router	Capacity	Form factor	400G QSFP-DD Ports	100G QSFP28 Ports
Cisco 8201	10.8 Tbps	1 RU	24	12
Cisco 8202	10.8 Tbps	2 RU	12	60
Cisco 8201-32FH	12.8 Tbps	1 RU	32	–
Cisco 8202-32FH-M	12.8 Tbps	2 RU	32	–
Cisco 8201-24H8FH	5.6 Tbps	1 RU	8	24

Cisco 8800 Series Routers

The Cisco 8800 Series delivers density and efficiency with the extensive scale, buffering, and all feature capabilities that are common to Cisco 8000 Series routers. The 8800 series routers provide up to approximately 260 Tbps through 648 400 GbE ports. The 8800 series includes four chassis to meet a broad set of network and facility requirements.

This table details the specifications of the routers.

Router	Capacity	Form factor	400G QSFP-DD Ports
Cisco 8804	Up to 57.6 Tbps	4-slot/10 RU	Up to 144
Cisco 8808	Up to 115.2 Tbps	8-slot/16 RU	Up to 288
Cisco 8812	Up to 172.8 Tbps	12-slot/21 RU	Up to 432
Cisco 8818	Up to 259.2 Tbps	18-slot/33 RU	Up to 648

Cisco 8800 Series Line Cards

The Cisco 8800 Series modular platform supports 400 GbE line cards.

This table details the specifications of the line cards.

Line Cards	Bandwidth	400G QSFP-DD Ports
8800-LC-36FH	14.4 Tbps	36
88-LC0-36FH-M	14.4 Tbps	36
88-LC0-36FH	14.4 Tbps	36

For information on ZR/ZR+ port support, see [400G ZR/ZR+ Transceivers, on page 14](#).

For more information about Cisco 8000 Series Routers, see the [Cisco 8000 Series Routers Data Sheet](#).

Cisco Network Convergence System 5500 Series

The Network Convergence System (NCS) 5500 platform offers high port density, high-performance forwarding, low jitter, and low power consumption.

Cisco NCS-57B1 Series Fixed Port Routers

The NCS-57B1-6D24-SYS and NCS-57B1-5DSE-SYS combine 4.8 Terabits of 400GE/100GE optimized forwarding capacity, QSFP-DD optics, deep packet buffering, full line-rate MACsec, Class C 1588 Precision Time Protocol (PTP), and Synchronous Ethernet (SyncE) in a power-efficient, 1-rack-unit package.

This table details the specifications of the routers.

Router	Capacity	Form factor	400G QSFP-DD Ports	100G QSFP-DD Ports
NCS-57B1-6D24-SYS	Up to 4.8 Tbps	1 RU	6	24
NCS-57B1-5DSE-SYS	Up to 4.4 Tbps	1 RU	5	24

For more information about Cisco NCS-57B1 Series Fixed Port Routers, see the [Cisco Network Convergence System 5700 Series: NCS-57B1 Fixed Chassis Data Sheet](#).

Cisco NCS 5500 Modular Chassis

The Cisco NCS 5500 modular chassis series is available in three system sizes: NCS 5504, NCS 5508, NCS 5516. All NCS systems are highly reliable and resilient platforms. They support a wide range of line card options. NCS 5500 modular router line cards and fabric modules directly attach to each other with connecting pins. In contrast, most traditional modular platform designs require a midplane.

This table details the specifications of the routers.

Platform	Capacity	Form factor	400G QSFP-DD Ports	100G QSFP28 Ports
NCS 5504	Up to 14.4 Tbps	4-Slot / 7 RU	Up to 96	Up to 144
NCS 5508	Up to 76.8 Tbps	8-Slot / 13 RU	Up to 192	Up to 288
NCS 5516	Up to 153.6 Tbps	16-Slot / 21 RU	Up to 384	Up to 576

For more information about Cisco Network Convergence System 5500 Series Modular Chassis, see the [Cisco Network Convergence System 5500 Series Modular Chassis Data Sheet](#).

NCS 5700 Series Line Cards

NCS 5700 series line cards are 400G line cards for the NCS 5500 Series modular chassis. NCS 5700 series line cards consists of two versions of 400GE optimized line cards: the base version and the scale version. The two 400GE optimized line cards in the NCS5700 series are NC57-24DD and NC57-18DD-SE.

For information on ZR/ZR+ port support, see [400G ZR/ZR+ Transceivers, on page 14](#).

For more information about Cisco Network Convergence System 5700 Series 400GE, see the [Cisco Network Convergence System 5700 Series: 400GE and 100GE Line Cards Data Sheet](#).

400G ZR/ZR+ Transceivers

The QDD-400G-ZR-S and QDD-400G-ZRP-S optical modules offload wavelength-division multiplexing (WDM) functionality to the router. The QDD-400G-ZR-S and QDD-400G-ZRP-S optical modules are DWDM C-band (196.1 to 191.3 THz with 100-MHz spacing) tunable optical modules. These optical modules enable high-bandwidth 400G links and support 400G Ethernet rate.

This table lists some specifications of the ZR/ZR+ pluggable modules.

Parameter	QDD-400G-ZR-S	QDD-400G-ZRP-S
Client Speed	400G, 4x100G	400G, 4x100G, 3x100G, 2x100G, 1x100G
Trunk Speed	400G	400G, 300G, 200G, 100G
FEC	cFEC	oFEC, cFEC
Modulation	16-QAM	16-QAM, 8QAM, QPSK
Frequency	C-Band, 196.1 To 191.3 THz	C-Band, 196.1 To 191.3 THz

The ZR/ZR+ pluggable optical modules are based on the QSFP-DD form factor. This form factor is a universal standard and ensures interoperability with other vendors.

For more information on Cisco 400G Digital Coherent Optics QSFP-DD Optical Modules, see the [Cisco 400G Digital Coherent Optics QSFP-DD Optical Modules Data Sheet](#).

Device Supported Software

This table shows the IOS XR Software necessary on the routers.

Product	400G ZR	400G ZR+
Cisco 8000 Series	7.3.2	7.3.2
Cisco NCS 5500 Series	7.3.2	7.3.2
Cisco ASR 9000 Series	7.3.2	7.3.2
Cisco NCS 540 Series	7.4.1	7.4.1

This table shows the required IOS XR Software version on the routers to support specific breakout modes.

The following table shows the required IOS XR Software version on the routers to support specific breakout modes on Bright ZR+ pluggable optical modules.

Cisco Network Convergence System 2000 Series

The Cisco Network Convergence System 2000 Series delivers agility, programmability, and massive scale across ultra-long haul, metro, and enterprise optical networks. Using the Cisco NCS 2000 Series, you can deploy a simple, yet intelligent dense wavelength-division multiplexing (DWDM) network that scales with operational ease. The NCS 2000 devices are managed by Shelf Virtualization Orchestrator (SVO).

Cisco NCS 2006 Shelf

The NCS 2006 shelf has eight horizontal cardslots. The Cisco NCS 2006 chassis is 6 RU and has six slots for service cards and two slots for controller cards. It supports multishelf management up of to 50 shelves.

For more information on Cisco Network Convergence System 2000 Series, see the [Cisco Network Convergence System 2000 Series Data Sheet](#).

Shelf Virtualization Orchestrator

Cisco NCS 2000 Shelf Virtualization Orchestrator (SVO) introduces programmability of optical network elements and automation with NETCONF interface and YANG models. SVO enables end-to-end, software-defined automated networks that maximize revenue to customers and ease the network turn-up, operation, and maintenance.

SVO is available with a server on a blade encasing a high-speed processor with virtualized instances of multiple reconfigurable optical add/drop multiplexer (ROADM), optical line amplifier (OLA), and dynamic gain equalizer (DGE) sites of the network. An SVO line card along with the application software provides functionality-based licenses for alarm correlation, performance monitoring, connection verification, and optical time domain reflectometry (OTDR).

The Cisco NCS 2000 SVO helps to maintain and improve customers' profitability with the orchestration of network elements and their functionalities. SVO allows the network elements to do only forwarding functions. SVO maintains the configuration and monitoring of the same at the node level with a centralized controller.

For more information on Cisco NCS 2000 Shelf Virtualization Orchestrator, see the [Cisco NCS 2000 Shelf Virtualization Orchestrator Data Sheet](#).

Control Cards

Cisco NCS 2000 Series Transport Node Controller 2 with Optical Time Domain Reflectometry (TNCS-2O) Card performs system initialization, provisioning, alarm reporting, maintenance, diagnostics, IP addressing, Data-Communications-Channel (DCC) termination, monitoring of system input voltage, system fault detection, and multishelf management connections. Optical Time Domain Reflectometry (OTDR) is used to provide information about the basic characteristics of the Optical fiber among Optical nodes, such as insertion loss, concentrate-point of reflection, fiber-to-fiber connection losses and reflectance.

For more information on Cisco Transport Node Controller and Transport Shelf Controller Cards, see the [Cisco Transport Node Controller and Transport Shelf Controller Cards Data Sheet](#).

ROADM Cards

The 20-SMRFS card is tunable over 96 channels in the C-band, at 50-GHz spacing on the ITU-T grid. The card provides the flex spectrum capability, which gives the flexibility to allocate channel bandwidth and increase the network scalability. With flex capability, the channel bandwidth is not fixed, but can be defined arbitrarily, with a specified granularity and within a given range. The card makes the network flexible as it allows you to reconfigure the optical channels on the run.

The 20-SMRFS card is a single-slot card that integrates two cross-connect blocks (multiplexer and demultiplexer), a variable-gain EDFA preamplifier, and a variable-gain EDFA booster amplifier. The card supports up to 20 directions for each ROADM node. The EDFA preamplifier in this card has gain ranges of 0–17 and 12–24 dB with controlled tilt and extended gain ranges of 20 dB and 35 dB with uncontrolled tilt.

For more information on Cisco NCS 2000 Flex Spectrum Single Module ROADM Line Cards, see the [Cisco NCS 2000 Flex Spectrum Single Module ROADM Line Cards Data Sheet](#).

Amplifier Cards

The Cisco NCS 2000 offers enhanced optical amplifier cards operating in the C-band region of the optical spectrum to extend the reach and capacity of a metro, regional, or long-haul network. The optical amplifier

cards are part of the Cisco NCS 2000 intelligent DWDM architecture that is engineered to reduce DWDM complexity and speed the deployment of next-generation networking solutions.

EDFA Cards

The OPT-EDFA-17 and OPT-EDFA-35 cards are C-band DWDM EDFA amplifiers and preamplifiers. The cards are true variable gain amplifiers, offering an optimal equalization of the transmitted optical channels over a wide gain range. They support 96 channels at 50-GHz channel spacing in the C-band (that is, 1528.77 to 1566.72-nm wavelength range). The OPT-EDFA-17 card delivers 20-dBm output power. The OPT-EDFA-35 card delivers +23-dBm output power. These cards do not contain midstage access loss for a Dispersion Compensation Unit (DCU). The cards provide a noise-figure optimized version of the EDFA amplifiers to cope with new modulation formats like PM-DQPSK, which do not need dispersion compensation.

For more information on Enhanced C-Band 96-Channel EDFA Amplifiers for the Cisco ONS 15454 Multiservice Transport Platform (MSTP), see the [Enhanced C-Band 96-Channel EDFA Amplifiers for the Cisco ONS 15454 MSTP Data Sheet](#).

EDRA Cards

The double-slot EDRA-2-26 card combines standard erbium-doped fiber amplifiers and a Raman amplifier to enable amplification on long unregenerated spans. These plug-in modules support an ultra-low noise figure that is critical for long-distance, high-bit-rate transmission. Supporting 96 channels in the C-band (wavelengths from 1528.77 to 1566.72 nm), they provide the reach and optical performance required to meet the most demanding distance requirements of service provider and enterprise DWDM networks. EDRA-2-26 includes an erbium-doped preamplifier, EDFA1, with a nominal gain of 14 dB and an erbium-doped booster amplifier, EDFA2. It supports a maximum span of 26 dB on standard single-mode fiber.

For more information on Cisco Network Convergence System 2000 Series Erbium Doped Raman Amplifiers, see the [Cisco Network Convergence System 2000 Series Erbium-Doped Raman Amplifiers Data Sheet](#).

Raman Amplifier Cards

The Cisco® ONS 15454 Multiservice Transport Platform (MSTP) High-Power Counter-Propagating Raman Amplifiers operate in the C-band region of the optical spectrum to extend the reach and capacity of regional, long-haul, and ultra-long-haul optical.

Raman amplifiers use the intrinsic properties of silica fiber in such a way that the transmission fibers themselves become a medium for amplification. This approach allows the attenuation of data signals transmitted over the fiber to be mitigated within the fiber itself. An amplifier using this principle is commonly known as a distributed Raman amplifier or simply, a Raman amplifier. The high-power counterpropagating unit injects counterpropagating optical power to generate a Raman effect in the span fiber and thus amplifies the signals propagating in the same fiber.

The single-slot RAMAN-CTP card supports counter Raman amplification on long unregenerated spans. The cards manage up to 96 ITU-T 50 GHz spaced channels over the C-band of the optical spectrum (wavelengths from 1528.77 to 1566.72 nm).

For more information on High-Power Counter-Propagating and Co-Propagating Raman units for the Cisco ONS 15454 Multiservice Transport Platform, see [High Power Counter-Propagating and Co-Propagating Raman units for the Cisco ONS 15454 Multiservice Transport Platform \(MSTP\)](#).

Passive Multiplexer and Demultiplexer Module

NCS1K-MD-64-C is an optical passive optical multiplexer and demultiplexer module. The new optical module is based on Athermal Wave Guide (AWG) providing 64 channels at 75-GHz space covering the extended C-band of optical spectrum. The passive module allows you to transmit 400G ZR and 400G ZR+ wavelengths.

NCS1K-MD-64-C is a bidirectional unit that has the MUX and the DEMUX functions implemented as two different sections. The NCS1K-MD-64-C module supports bidirectional connection toward the Router/DCI that is equipped with QDD-400G-ZR-S and QDD-400G-ZRP-S.

For more information on Cisco NCS 1000 Mux/Demux 64-Channel Patch Panel module, see [Cisco NCS 1000 Mux/Demux 64-Channel Patch Panel Data Sheet](#)

Passive Patch Panel Modules

The passive optical modules are used to build the optical network system.

MPO-16 to 16-LC Fan-Out Module

The MPO-16 to 16-LC fan-out module is a double slot module with one MPO-16 connector (COM) and eight LC duplex connectors (Port-i-TX/RX). It contains 16 photodiodes to monitor the power of the channel input ports. The MPO-16 to 16-LC fan-out module provides fan-out of the MPO-16 connector to or from the LC connections and interconnects the optical modules having LC connectors (TXP) with modules having MPO-16 connectors (SMR20 FS).

For more information on Cisco Network Convergence System 2000 Series Passive Patch Panel Modules, see the [Cisco Network Convergence System 2000 Series Passive Patch Panel Modules Data Sheet](#).

Network Planning Components

Use the following components to plan the network:

- [Cisco WAN Automation Engine, on page 18](#)
- [Cisco Optical Network Planner, on page 19](#)

Cisco WAN Automation Engine

The Cisco WAN Automation Engine (WAE) platform is an open, programmable framework that interconnects software modules, communicates with the network, and provides APIs to interface with external applications.

Cisco WAE provides the tools to create and maintain a model of the current network through the continual monitoring and analysis of the network and the traffic demands that are placed on it. At a given time, this network model contains all relevant information about a network, including topology, configuration, and traffic information. You can use this information as a basis for analyzing the impact on the network due to changes in traffic demands, paths, node and link failures, network optimizations, or other changes.

Cisco WAE is used for IP and optical network planning of multi-vendor networks.

For more information, see [Cisco WAN Automation Engine Data Sheet](#)

Cisco Optical Network Planner

Cisco Optical Network Planner (Cisco ONP) is a tool that models and tests Optical Transport Networks and Dense Wavelength Division Multiplexing optical networks using a graphical environment. The primary purpose of Cisco ONP is to design and validate networks of the NCS 2000 series and NCS 1010. Using the Cisco ONP tool, you create multiple instances of a network, modify different parameters at each instance, and compare the instances. Cisco ONP performs the following:

- Generates a rack view of all the sites in the network
- Shows the differences between the instances
- Provides a complete Bill of Materials (BOM) for the network

Cisco ONP models the optical network, generates the BOM, and provides detailed information about the network. This information includes connection reports, optical reports, and traffic matrix.



Note Cisco ONP must be used to perform the final optical network feasibility analysis and generate production network designs.

For more information, see [Cisco Optical Network Planner \(CONP\) Data Sheet](#)

Automation Components

Automation of the Routed Optical Networking solution follows the IETF ACTN SDN controller framework. Cisco Optical Network Controller is the Cisco optical domain PNC, Crosswork Network Controller (Crosswork Network Controller) is the multivendor IP-domain PNC. Crosswork Hierarchical Controller unifies IP and optical information from Cisco Optical Network Controller and Crosswork Network Controller, providing multi-layer and multi-domain visualization, Routed Optical Networking service assurance, and Routed Optical Networking service management in the MDSC role.

Figure 6: IETF ACTN – Open Automation Reference Framework

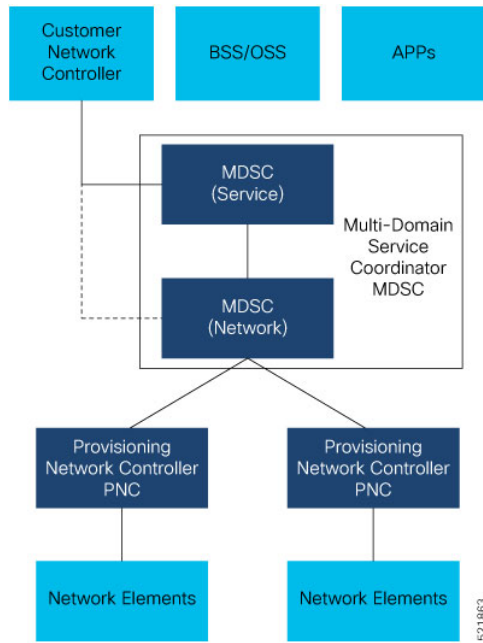

The automation stack consists of the following components:

- Crosswork Hierarchical Controller manages Routed Optical Networking deployments by leveraging advanced multi-layer and multi-vendor capabilities to provision and assure both IP and optical networks.
- Cisco Optical Network Controller helps in configuring Cisco optical network elements, monitors the topology (physical or virtual) of networks, performs optical path computation, and collects information about the topology.
- Crosswork Network Controller simplifies and automates intent-based network service provisioning, monitoring, and path optimization in a IP multi-vendor network environment with a common GUI and API.
- EPNM is the unified EMS that performs deep inventory. It is an element management system for device lifecycle management for converged IP and optical networks. EPNM also collects fault and alarm information, and performs node-level performance measurement statistics collection.

Routed Optical Networking Automation Solution Architecture

The following diagram provides a high-level illustration of how the solution's components work together.

Figure 7: Routed Optical Networking Automation Architecture

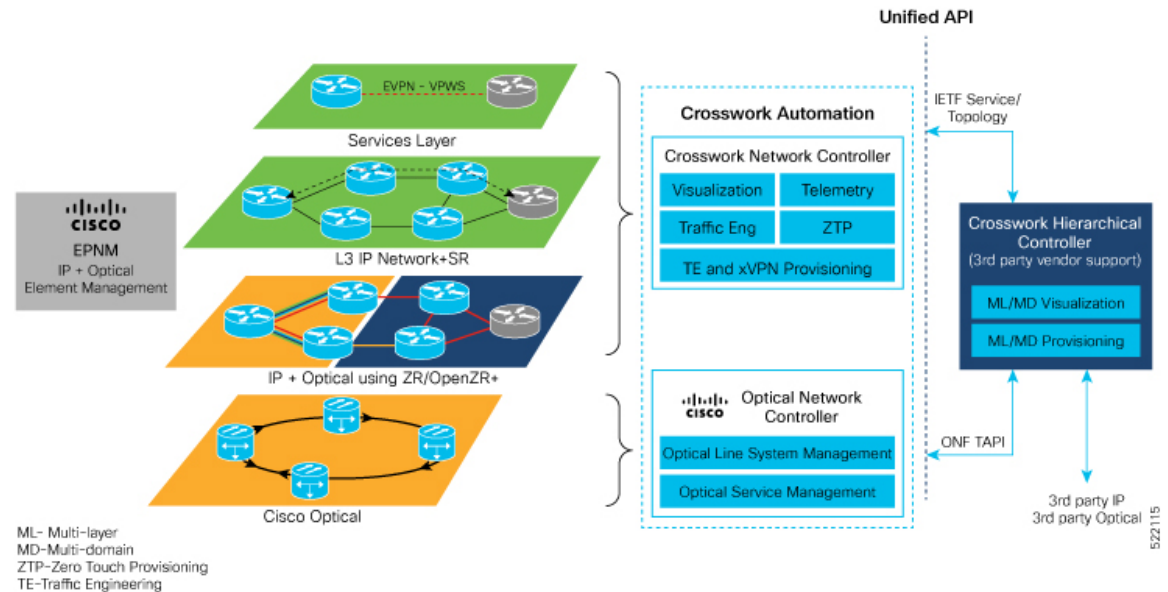

Cisco Crosswork Hierarchical Controller

Cisco Crosswork Hierarchical Controller provides an API and single pane of glass UI for Routed Optical Networking infrastructure and services. It manages your existing optical and packet domains with the same unified approach. Routed Optical Networking with Crosswork Hierarchical Controller dramatically simplifies the operation of multi-layer networks which before now were commonly managed by independent NMS/EMS products.

Key Capabilities

Cisco Crosswork Network Controller

Cisco Crosswork Network Controller (Crosswork Network Controller) is a network automation solution for deploying and operating IP and Routed Optical Networking converged transport networks. Crosswork Network Controller delivers increased service agility, cost efficiency, and optimization for faster time-to-customer value and lower operating costs. The solution combines intent-based network automation to deliver critical capabilities for service orchestration and fulfillment, network optimization, service path computation, device deployment and management, and anomaly detection and automatic remediation. Using telemetry gathering and automated responses, Cisco Crosswork Network Controller delivers network optimization capabilities that are nearly impossible to replicate even with a highly skilled and dedicated staff operating the network.

The integrated solution combines core capabilities from multiple innovative, industry-leading products including Cisco Network Services Orchestrator (NSO), Cisco Segment Routing Path Computation Element (SR-PCE), and the Cisco Crosswork suite of applications. Its unified user interface allows real-time visualization of the network topology and services, as well as service and transport provisioning, through a single pane of glass.

The Crosswork Network Controller features are:

- **Active Topology:** Active Topology's logical and geographical maps provide real-time visibility into the physical and logical network topology, service inventory, and SR-TE policies and RSVP-TE tunnels, all in a single pane of glass. They enable operators to see, at-a-glance, the status and health of the devices, services, and policies.
- **Common UI and API:** All Crosswork Network Controller functionality is provided within a single, common GUI. This common UI brings together the features of all components of Crosswork Network Controller, including common inventory, network topology and service visualization, service and transport provisioning, and system administration and management functions.

All Crosswork Network Controller functionality is provided within a single, common GUI. This common UI brings together the features of all components of Crosswork Network Controller, including common inventory, network topology and service visualization, service and transport provisioning, and system administration and management functions.

- **Platform Infrastructure and Shared Services:** The Platform Infrastructure provides a resilient and scalable platform on which all Cisco Crosswork applications can be deployed. It is a microservices-based platform that brings together streaming telemetry and model-driven application programming interfaces (APIs) to redefine service provider network operations. It retrieves real-time information from the network, analyzes the data, and uses APIs to apply network changes. It employs a cluster architecture to be extensible, scalable, and highly available.

The essential components of Crosswork Network Controller are:

- **Cisco Crosswork Optimization Engine:** Cisco Crosswork Optimization Engine provides real-time network optimization allowing operators to effectively maximize network capacity utilization and increase service velocity. Crosswork Optimization Engine enables closed loop tracking of the network state, reacting quickly to changes in network conditions to support a self-healing network. See [Cisco Crosswork Optimization Engine Data Sheet](#)
- **Cisco Crosswork Data Gateway:** Cisco Crosswork Data Gateway (Crosswork Data Gateway) is a secure, common collection platform for gathering network data from multivendor devices. It is an on-premise application that is deployed close to network devices. Crosswork Data Gateway supports multiple data collection protocols including MDT, SNMP, CLI, standards-based gNMI (dial-in), and syslog. Crosswork Data Gateway can collect any type of data as long as the data can be delivered over one of the supported protocols. See [Cisco Crosswork Data Gateway Data Sheet](#)
- **Cisco Segment Routing Path Computation Element:** Cisco Segment Routing Path Computation Element (SR-PCE) is an IOS-XR multidomain stateful Path Computation Engine (PCE) supporting both segment routing (SR) and Resource Reservation Protocol (RSVP). Cisco SR-PCE builds on the native PCE abilities within IOS-XR devices, and provides the ability to collect topology and segment routing IDs through BGP-LS, calculates paths that adhere to service SLAs, and programs them into the source router as an ordered list of segments. A Path Computation Client (PCC) reports and delegates control of headend tunnels that are sourced from the PCC to a PCE peer. The PCC and PCE establish a Path Computation Element Communication Protocol (PCEP) connection that SR-PCE uses to push updates to the network and reoptimize paths where necessary.
- **Cisco Network Services Orchestrator (NSO) Function Packs:** Cisco Crosswork Network Controller is packaged with the following Cisco NSO function packs:
 - SR-TE core function pack (CFP)
 - Sample function packs for IETF-compliant L2VPN and L3VPN provisioning
 - Sample IETF-compliant RSVP-TE function pack

The optional components of Crosswork Network Controller are:

- **Cisco Crosswork Health Insights:** Cisco Crosswork Health Insights is a network health application that performs real-time Key Performance Indicator (KPI) monitoring, alerting, and troubleshooting. Cisco Crosswork Health Insights enables programmable monitoring and analytics. It provides a platform for dynamically addressing changes to the network infrastructure. See [Cisco Crosswork Change Automation and Health Insights Data Sheet](#)
- **Cisco Crosswork Zero-Touch Provisioning:** The Cisco Crosswork Zero-Touch Provisioning (ZTP) application is an integrated solution for onboarding and provisioning new IOS-XR devices automatically. ZTP results in faster deployment of new hardware at lower operating costs. Operators can quickly and easily bring up devices using a Cisco-certified software image and a day-zero software configuration. Once provisioned in this way, the new device is onboarded to the Crosswork device inventory where it can be monitored and managed like other devices. See [Cisco Crosswork Zero-Touch Provisioning Data Sheet](#)
- **Cisco Service Health:** Service Health substantially reduces the time required to detect and troubleshoot service quality issues. It monitors the health status of provisioned L2/L3 VPN services and enables operators to pinpoint why and where a service is degraded. It can also provide service-specific monitoring, troubleshooting, assurance, and proactive causality through a heuristic model that visualizes the:
 - Health status of subservices (device, tunnel) to a map when a single service is selected.
 - Service logical dependency tree and help the operator in troubleshooting in case of degradation by locating where the problem resides, an indication of possible symptoms, and impacting metrics in case of degradation.
 - Historical view of service health status up to 60 days
- **Crosswork EMS Services:** Element Management System (EMS) services are bundled with the Crosswork Network Controller Advantage pack. The EMS functions include inventory, fault, and Software Image Management (SWIM).
 - Inventory service integrates deep inventory collection with Cisco Crosswork's Device Lifecycle Management (DLM). It enriches the existing device onboarding workflow to gather more insights about the device. Built-in device packages enable deep inventory collection when the user manually attaches a device to the Crosswork Data Gateway. The collection is persisted in the database and monitored using the Inventory APIs.
 - Fault service is associated with alarm management. It provides API support for subscription, request, retrieval, and auto-clearing of alarms for Topology Visualization services. Monitored using the Fault APIs, the fault service improves the existing topology views by showing the alarm status for devices and links.
 - SWIM is integrated with Crosswork Change Automation and managed with SWIM APIs. It allows operators to view, import, and delete software images, as well as push software images to the devices in the network. SWIM improves compliance, accelerates upgrades, and improves the network engineer experience.

As it uses standards-based protocols, Cisco Crosswork Network Controller is multivendor capable for:

- Network service orchestration
- Telemetry data collection
- Topology and transport discovery

- Transport path computation

For more information on Cisco Crosswork Network Controller, see the [Cisco Crosswork Network Controller Data Sheet](#).

Cisco Optical Network Controller

Cisco Optical Network Controller (Optical Network Controller) is an SDN Domain Controller for optical networks. Optical Network Controller collects optical data and uses it to provide network information in an abstracted format to higher layer controllers. This abstraction enables centralized control of optical networks.

Cisco Optical Network Controller serves as a domain controller for optical products and provides data to Hierarchical Controllers. Optical Network Controller supports a standardized TAPI model, which enables it to abstract the device level details from a hierarchical controller. As a Provisioning Network Controller, Optical Network Controller helps in configuring the network elements, monitors the topology (physical or virtual) of networks, and collects information about the topology. Cisco Optical Network Controller improves hardware capability by supporting addition of optical applications to the controller. It centralizes some of the control loop functions that are critical for maintaining and programming the optical components in the hardware.

For more information on Cisco Optical Network Controller, see the [Cisco Optical Network Controller Data Sheet](#).

Cisco Network Services Orchestrator

Cisco Network Services Orchestrator (NSO) is an orchestration platform that takes advantage of pluggable function packs to translate networkwide service intent into device-specific configuration. Cisco NSO provides flexible service orchestration and lifecycle management across physical network elements and cloud-based virtual network functions (VNFs), fulfilling the role of the Network Orchestrator within the ETSI architecture. It provides complete support for physical and virtual network elements, with a consistent operational model across both. It can orchestrate across multivendor environments and support multiple technology stacks, enabling extension of end-to-end automation to virtually any use case or device.

Cisco NSO has a rich set of APIs designed to allow developers to implement service applications. It provides the infrastructure for defining and executing the YANG data models necessary to realize customer services. NSO is also responsible for providing the overall lifecycle management at the network service level.

For more information on Cisco Network Services Orchestrator, see [Cisco Network Services Orchestrator Data Sheet](#)

Cisco NSO Routed Optical Networking Core Function Pack

The NSO Routed Optical Networking CFP uses NSO to automate the management of the devices in the Routed Optical Networking network and perform end-to-end service provisioning seamlessly across the IP layer and optical layers. The NSO Routed Optical Networking CFP uses the same NSO instance as Crosswork Network Controller.

Figure 8: Routed Optical Networking ML Function Pack

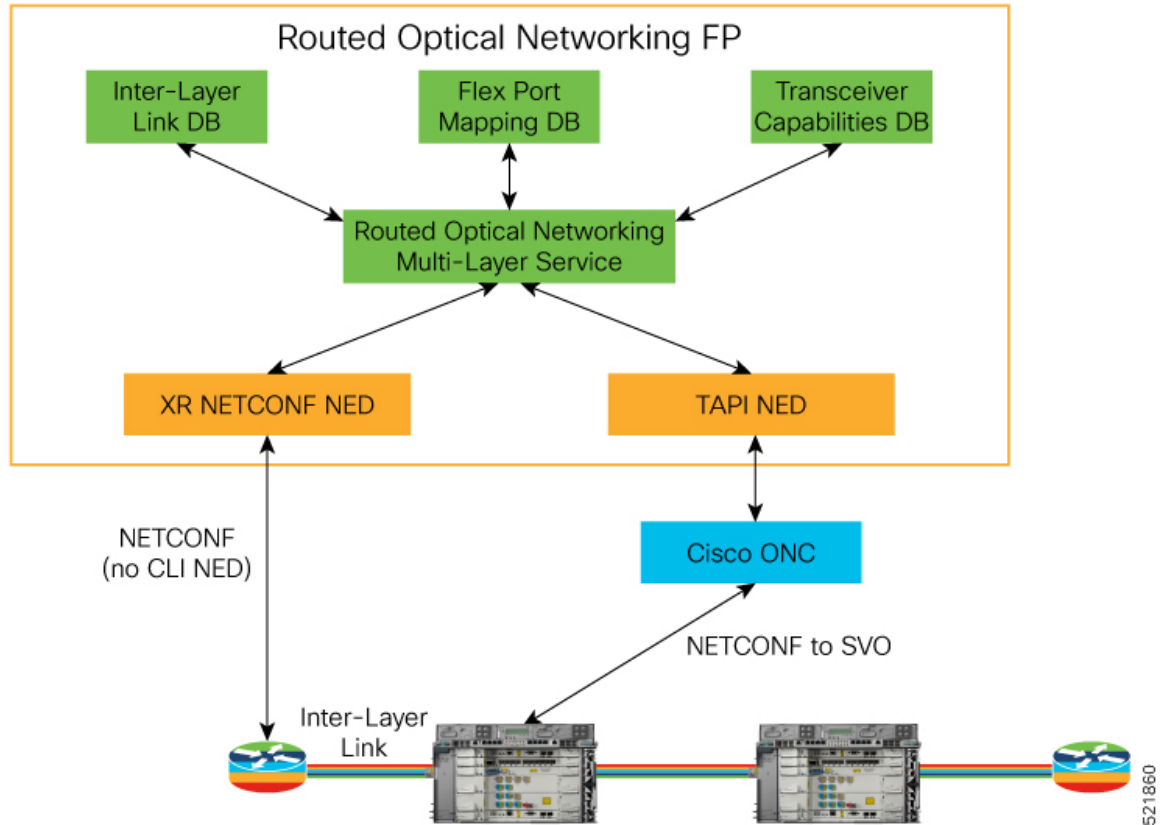

This table describes the functions of different components of the Routed Optical Networking ML Function Pack.

Component	Function
Inter-layer link DB	Stores the IP to optical physical connections between the router and the optical line system
Flex-port mapping DB	Maintains chassis and line card PID database for ports that must be pre-provisioned before the ZR configuration. NCS57-18DD-SE and ASR 9000 multi-rate line cards must be preprovisioned
Transceiver capabilities DB	Map optics PID to capabilities. ZR = 400G, 4x100G, ZR+ = 100G, 2x100G, 3x100G, 4x100G, or 400G
Routed Optical Networking ML service	Performs IP and ZR router provisioning and optical provisioning
XR NETCONF NED	Used to provision router elements. Native YANG models used
TAPI NED	NETCONF-based NED to communicate with Optical Network Controller via TAPI



Note The inter-layer link services are user-defined. Flex-port mapping and transceiver capabilities are installed as part of the function pack, but can be modified by the user.

The Routed Optical Networking ML service connects two DWDM optical ports with a fixed bandwidth of either 100, 200, 300, or 400G between the routers. This service is characterized by a single DWDM wavelength.

The Routed Optical Networking ML service helps to:

- Provision line card modes to support 400G optics
- Create the optical circuit via the Optical Network Controller
- Configure the optical parameters on the ZR or ZR+ optics
- Assign IP address to Ethernet interfaces or bundle interfaces
- Bundle discrete Ethernet interfaces

Routed Optical Networking CFP communicates with Cisco Optical Network Controller by using the standardized Transport Application Program Interface (TAPI) models through the TAPI NED. After the Cisco Optical Network Controller provisions the optical network, it sends notifications to NSO. NSO then provisions the router service to configure the ZR pluggable routers.

Cisco Evolved Programmable Network Manager

The Cisco Evolved Programmable Network Manager (EPNM) is an all-in-one management solution for today's converging packet and optical networks.

Cisco EPN Manager supports the Cisco Routed Optical Network architecture and delivers Cisco Optical and IP full device management and Cisco optical circuit network assurance. The Cisco EPN Manager discovers and represents the physical and logical configuration of managed devices.

Cisco EPN Manager provides full software image management and configuration management for the Cisco optical and IP devices.

A graphical chassis view with status indications gives network operators a live-live view of the device. EPNM differentiates itself from other network management systems with the ability to discover optical circuit from the network and maintain up-to-date representation of the optical circuit and the infrastructure dependency.

EPNM helps reduce the time to know about network or optical circuit-affecting conditions by correlating raw events and associating alarm conditions with affected managed network elements, network connectivity, and circuit. Contextual dashboards and 360-degree views (device and port levels) display the most relevant information for fast and efficient problem identification and remediation. To help reduce the time to restore and repair, EPNM guides the troubleshooting process using alarm correlation, identification of affected components or optical circuit, and connectivity. EPNM collects fault and alarm information, and performs node-level performance measurement statistics collection.

For more information on Cisco Evolved Programmable Network Manager, see the [Cisco Evolved Programmable Network Manager Data Sheet](#).

Routed Optical Networking Components Software Versions

IOS-XR Software Components

Cisco IOS XR is a modern and flexible network operating system. XR improves operational efficiencies with management API integration to provide near real-time, actionable telemetry data. Two features of IOS XR that enable Routed Optical Networking are:

- **YANG-modeled management layer APIs:** To automate device provisioning and management. These models include native IOS XR YANG models and OpenConfig models.
- **Streaming telemetry capabilities:** For cadence-based or event-driven monitoring of data that is derived from YANG-modeled paths in the manageability layer over gRPC, TCP, or UDP.

Data models provide an alternate centralized way to configure devices instead of using the CLI or SNMP and to collect operational data from Cisco devices. Because the data models are standards-based, the same procedures are able to configure or collect data from non-Cisco devices as well. This ability makes them ideal for customers that support multiple vendors. You can use a centralized management platform to configure or collect data from multiple Cisco devices. The data model architecture allows for automating these procedures.

Network Configuration (NETCONF) Protocol

NETCONF is a standard-based and XML-encoded protocol. NETCONF provides the transport to communicate YANG formatted configuration or operational data requests from an application, which runs on a centralized management platform, to the Cisco device that you wish to configure or request operational data from. It provides transaction-based services, such as aborting the entire configuration request when a portion of that configuration request fails.

NETCONF uses a simple Remote Procedure Call based mechanism to facilitate communication between clients (centralized management platform script or application) and servers (Cisco switch or router). It uses SSH as the transport layer across network devices.

Yet Another Next Generation Data Modeling Language

YANG is a standards-based data modeling language. You can use YANG to create device configuration requests or requests for operational (**show** commands) data. It has a structured format similar to a computer program that is human-readable. Several applications that can run on a centralized management platform to create these configuration and operational data requests are available.

There are two types of YANG models:

- Standard (common) YANG data model that applies to all vendors. (For example, a request to disable or shut down an Ethernet interface is identical for both Cisco and non-Cisco devices.)
- Device (native, vendor-specific) data models that facilitate configuring or collecting operational data concerning proprietary vendor features.

This table lists Cisco native models, their Open Config equivalents used in the Routed Optical Networking solution and their functions.

Native Model	Open Config	Function
Cisco-IOS-XR-platform-oper	openconfig-platform	Retrieve line card information for flex-port mapping
Cisco-IOS-XR-optics-port-mode-cfg	No equivalent	Configure flex port modes
Cisco-IOS-XR-controller-optics-oper	openconfig-platform openconfig-platform-transceiver	Retrieve optics PID information
Cisco-IOS-XR-controller-optics-cfg	openconfig-terminal-device openconfig-platform-transceiver	Configure ZR optical parameters
Cisco-IOS-XR-um-if-bundle-cfg	openconfig-if-aggregate	Bundle configuration
Cisco-IOS-XR-um-interface-cfg	openconfig-interfaces	IPv4/IPv6 interface configuration
Controller-otu-oper	No equivalent	Coherent DSP operation data

Model Driven Telemetry

Telemetry is an automated communications process that you use to collect measurements and other data at remote or inaccessible points and transmit to receiving equipment for monitoring. Model-driven telemetry (MDT) provides a mechanism to stream YANG-modeled data to a data collector. Model-driven telemetry allows network devices to continuously stream real-time configuration and operating state information to subscribers.

Applications can subscribe to specific data items they need, by using standards-based YANG data models over NETCONF, RESTCONF, or gRPC Network Management Interface (gNMI) protocols. You can also create subscriptions by using CLIs if they are configured subscriptions. Devices publish structured data at a defined cadence, or on-change, based on the subscription criteria and data type. See [Troubleshoot Provisioning Issues, on page 49](#) for information on telemetry sensor paths and corresponding data fields.

MDT leverages structured data models that the networking device supports. MDT provides critical data that is defined in those data models. Telemetry helps you to manage your multivendor network using a common network management system, a process, and applications. The data that is collected from the network are standards-based and are uniform across vendor implementations.



CHAPTER 4

Deployment Topologies

This chapter describes examples of deployment topologies that utilize the Routed Optical Networking architecture.

Routed Optical Networking supports the following deployment topologies.

- Metro/Regional—This topology is used for shorter reach metro use cases and longer regional use cases.
- Long Haul—This topology is used for distances greater than 400 km. The QDD-400G-ZR-S optic has a maximum reach of 120 km. Longer distances require the use of QDD-400G-ZRP-S optics.

The Routed Optical Networking solution architecture or network design is the same for in network (core, aggregation, or DCI). The only differentiating factor is the hardware that is used for any deployment. The following topologies are examples of specific hardware deployments.

- [Metro/Regional Topology, on page 29](#)
- [Mesh Topology, on page 32](#)
- [Long Haul Topology, on page 36](#)

Metro/Regional Topology

Figure 9: 400G-ZR P2P Short Haul Applications with Cisco NCS 2006



This diagram displays the wiring diagram for the metro/regional topology:

Figure 10: Wiring Diagram for a Metro/Regional Topology

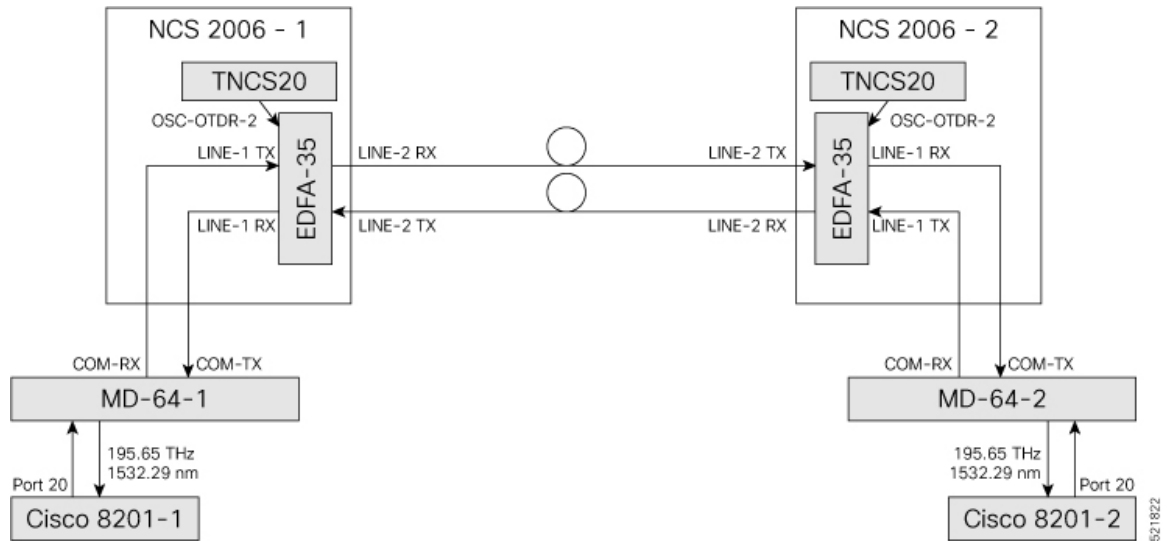

In this sample topology, we assume that Cisco 8201-1 is the source router and Cisco 8201-2 is the destination router.

Topology Components

To build this topology, you need the following hardware:

- Cisco 8200 Series Routers
- NCS1K-MD-64-C Modules
- Cisco NCS 2006
- TNCS-20 Cards
- OPT-EDFA-35 Cards
- QDD-400G-ZR-S transceiver
- LC/LC cables

For more information, see [Hardware Components, on page 11](#).

Port Connections

To build this topology, connect the cables in the following sequence:

1. On the Cisco 8201-1 and Cisco 8201-2 routers:
 - a. Align the QDD-400G-ZR-S transceiver module in front of the transceiver socket opening in Port 20. Then, carefully slide the transceiver into the socket until the transceiver comes in contact with the socket electrical connector.
 - b. Holding the pull-tab, seat the transceiver in the module's transceiver socket fully until it clicks.
 - c. Attach an LC/LC fiber immediately to the QDD-400G-ZR-S transceiver module.

- d. Connect the other end of the LC/LC fiber to the corresponding bulkhead adapter on the front panel of the NCS1K-MD-64-C (MD-64-1) module. In this sample topology, we use channel ID 7, which corresponds to a frequency of 195.65 THz (a wavelength of 1532.29 nm).
2. Connect an LC/LC fiber from the COM-RX port of the MD-64-1 module to the LINE-1-TX port of the EDFA 35 amplifier in NCS 2006-1.
3. Connect an LC/LC fiber from the COM-TX port of the MD-64-1 module to the LINE-1-RX port of the EDFA 35 amplifier in NCS 2006-1.
4. Connect an LC/LC fiber from the OSC-OTDR-2 port on the TNCS-2O card to the OSC port on the EDFA 35 card (NCS 2001-1).
5. Connect an LC/LC fiber from the LINE-2-RX port of the EDFA-35 card (NCS 2006 -1) to the outside plant fiber that is connected to the LINE-2-TX port of EDFA-35 card (NCS 2006 -2).
6. Connect an LC/LC fiber from the LINE-2-TX port of the EDFA-35 card (NCS 2006 -1) to the outside plant fiber that is connected to the LINE-2-RX port of EDFA-35 card (NCS 2006 -2).
7. Connect an LC/LC fiber from the OSC-OTDR-2 port on the TNCS-2O card to the OSC port on the EDFA 35 card (NCS 2006-2).
8. Connect an LC/LC fiber from the LINE-1-RX port of the EDFA-35 (NCS 2006 -2) to the COM-TX port of the MD-64-2 module.
9. Connect an LC/LC fiber from the LINE-1-TX port of the EDFA-35 (NCS 2006 -2) to the COM-RX port of the MD-64-2 module.

Next Steps

After you complete building the topology, perform the following steps:

- [Import the Cisco ONP Configuration File into SVO.](#)
- [Manage Expected Input Power](#)

Mesh Topology

Figure 11: Optical Bypass with Colorless Add/Drop and 4-Degree ROADM Node

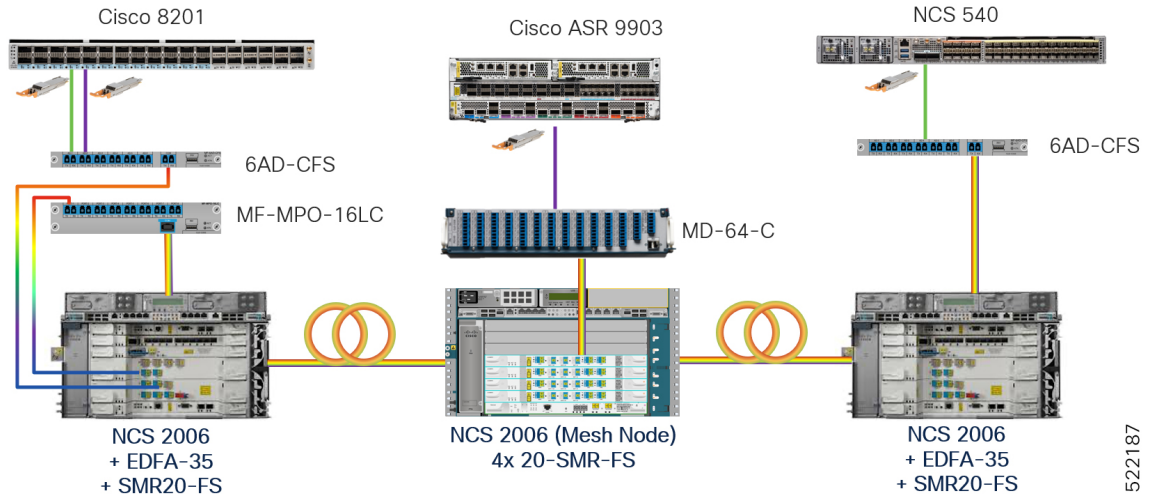

522187

This figure displays the NCS 2006 mesh node in detail with mesh panels:

Figure 12: 4-Degree Mesh Node Configuration

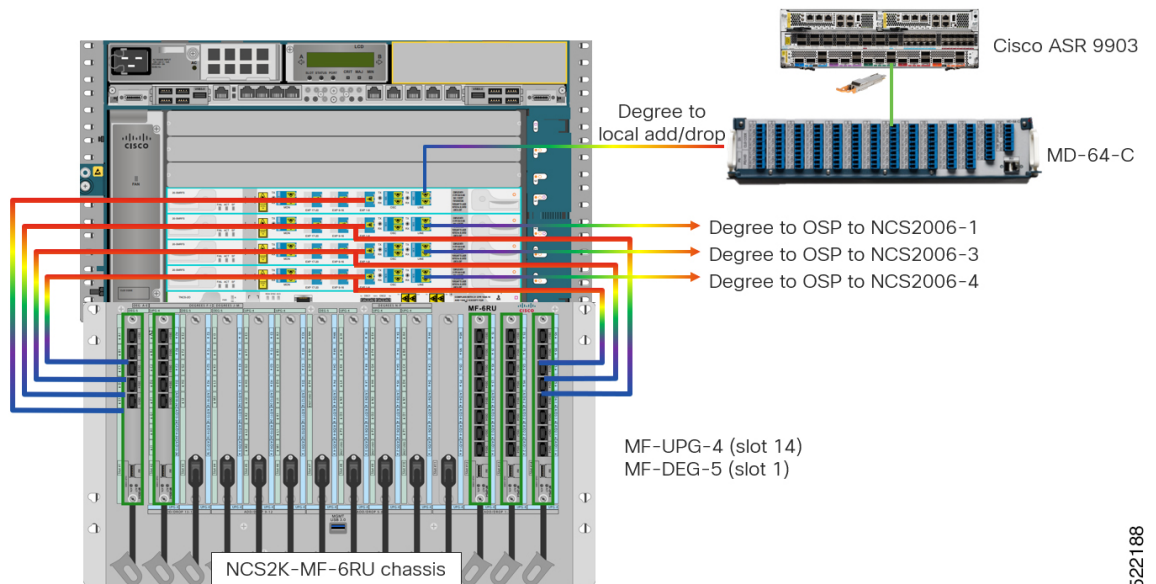

522188

This diagram displays the wiring diagram for the mesh topology:

Figure 13: Wiring Diagram for a Mesh Topology

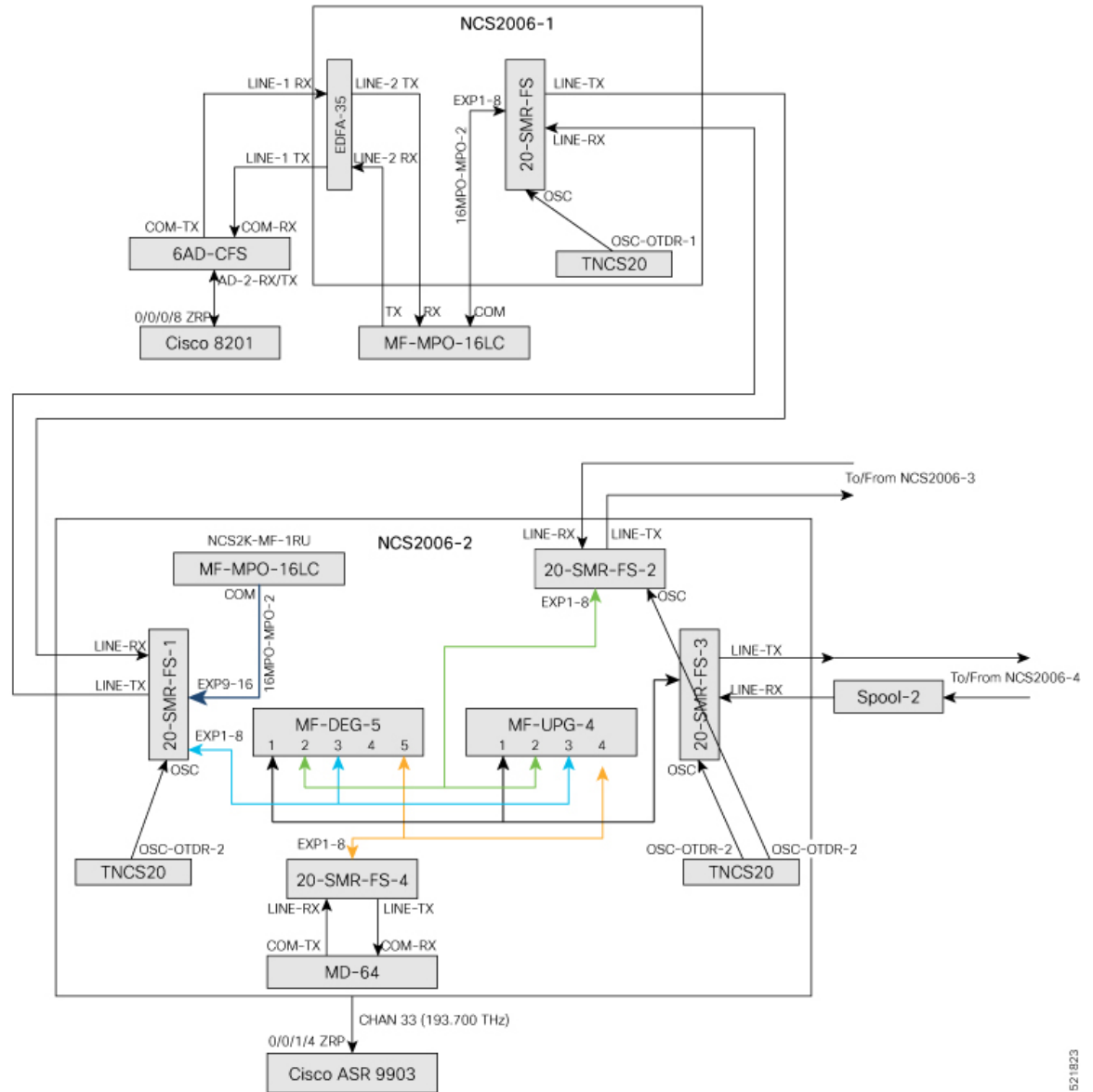

In this sample topology, we assume that Cisco 8201 is the source router and Cisco ASR 9903 is the destination router. This example uses a four-degree node. Nodes with lesser or more degrees are also supported. NCS2006-2 is a four-degree mesh node that drops a colored wavelength on the Cisco ASR 9903 router. In this example, the MD-64 unit is used as a fixed channel muxponder but other options can also be connected to the 20-SMR-FS card. The other degrees are connected to NCS 2000 nodes in the network.

Topology Components

To build this topology, you need the following hardware:

- Cisco 8200 Series routers
- Cisco ASR 9903 routers

- NCS1K-MD-64-C modules
- 6-AD-CFS units
- MF-DEG-5 units
- MF-UPG-4 units
- MF-MPO-16LC units
- Cisco NCS 2006 shelves
- TNCS-2O Cards
- OPT-EDFA-35 Cards
- 20-SMR-FS cards
- QDD-400G-ZR-S transceivers
- LC/LC cables
- 16MPO-MPO-2 cables
- ONS-MPO16-2x8-2 cables

For more information, see [Hardware Components, on page 11](#).

Port Connections

To build this topology, connect the cables in the following sequence:

1. On the Cisco 8201 router:
 - a. Align the QDD-400G-ZR-S transceiver module in front of the transceiver socket opening in Port 4. Then, carefully slide the transceiver into the socket until the transceiver comes in contact with the socket electrical connector.
 - b. Holding the pull-tab, seat the transceiver in the module's transceiver socket fully until it clicks.
 - c. Attach an LC/LC fiber immediately to the QDD-400G-ZR-S transceiver module.
 - d. Connect the other end of the LC/LC fiber to the corresponding bulkhead adapter on the front panel of the 6AD-CFS module (AD-2 RX/TX port). In this sample topology, we use channel ID 33, which corresponds to a frequency of 193.700 THz.
2. Connect an LC/LC fiber from the COM-RX port of the 6AD-CFS module to the LINE-1-TX port of the EDFA 35 amplifier in NCS 2006-1.
3. Connect an LC/LC fiber from the COM-TX port of the 6AD-CFS module to the LINE-1-RX port of the EDFA 35 amplifier in NCS 2006-1.
4. Connect an LC/LC fiber from the LINE-2-RX port of the EDFA-35 card (NCS 2006 -1) to the TX port of the MF-MPO-16LC unit.
5. Connect an LC/LC fiber from the LINE-2-TX port of the EDFA-35 card (NCS 2006 -1) to the RX port of the MF-MPO-16LC unit.
6. Connect an 16MPO-MPO-2 fiber from the EXP1-8 port of the 20-SMR-FS card (NCS 2006 -1) to the COM port of the MF-MPO-16LC unit.

7. Connect an LC/LC fiber from the OSC-OTDR-2 port on the TNCS-2O card to the OSC port on the 20-SMR-FS card (NCS 2006 -1).
8. Connect an LC/LC fiber from the LINE-TX port of the 20-SMR-FS card (NCS 2006 -1) to the LINE-RX port of the 20-SMR-FS-1 card (NCS 2006 -2).
9. Connect an LC/LC fiber from the LINE-RX port of the 20-SMR-FS card (NCS 2006 -1) to the LINE-TX port of the 20-SMR-FS-1 card (NCS 2006 -2).
10. Connect an LC/LC fiber from the OSC-OTDR-2 port on the TNCS-2O card to the OSC port on the 20-SMR-FS-1 card (NCS 2006-2).
11. Connect an 16MPO-MPO-2 fiber from the EXP9-16 port of the 20-SMR-FS-1 card (NCS 2006 -2) to the COM port of the MF-MPO-16LC unit.
12. Connect one end of the ONS-MPO16-2x8-2 cable to the EXP1-8 port of the 20-SMR-FS-1 card (NCS 2006 -2). Connect the other two ends to port 3 of the MF-DEG-5 unit and MF-UPG-4 unit respectively.
13. Connect one end of the ONS-MPO16-2x8-2 cable to the EXP1-8 port of the 20-SMR-FS-2 card (NCS 2006 -2). Connect the other two ends to port 2 of the MF-DEG-5 unit and MF-UPG-4 unit respectively.
14. Connect one end of the ONS-MPO16-2x8-2 cable to the EXP1-8 port of the 20-SMR-FS-3 card (NCS 2006 -2). Connect the other two ends to port 1 of the MF-DEG-5 unit and MF-UPG-4 unit respectively.
15. Connect one end of the ONS-MPO16-2x8-2 cable to the EXP1-8 port of the 20-SMR-FS-4 card (NCS 2006 -2). Connect the other end to port 5 of the MF-DEG-5 unit only.
16. Connect an LC/LC fiber from the OSC-OTDR-2 port on the TNCS-2O card to the OSC port on the 20-SMR-FS-2 card (NCS 2006-2).
17. Connect an LC/LC fiber from the OSC-OTDR-2 port on the TNCS-2O card to the OSC port on the 20-SMR-FS-3 card (NCS 2006-2).
18. Connect LC/LC fibers from the LINE-TX and LINE-RX ports of 20-SMR-FS-2 card (NCS 2006-2) to the ports of NCS2006-3.
19. Connect LC/LC fibers from the LINE-TX and LINE-RX ports of 20-SMR-FS-3 card (NCS 2006-2) to the ports of NCS2006-4.
20. Connect an LC/LC fiber from the LINE-RX port on the 20-SMR-FS-4 card (NCS 2006-2) to the COM-TX port of the MD-64 unit.
21. Connect an LC/LC fiber from the LINE-TX port on the 20-SMR-FS-4 card (NCS 2006-2) to the COM-RX port of the MD-64 unit.
22. Connect one end of the LC/LC fiber to the corresponding bulkhead adapter on the front panel of the NCS1K-MD-64-C (MD-64-1) module. Connect the other end of the fiber to the QDD-400G-ZR-S transceiver module installed in port 4 of the ASR 9903 router.

Next Steps

After you complete building the topology, perform the following steps:

- [Import the Cisco ONP Configuration File into SVO.](#)
- [Manage Expected Input Power](#)

Long Haul Topology

This diagram displays the architecture that is used for long-haul networks. This topology uses several regular amplifier nodes (ILA) along with DGE nodes. The ILA nodes span from 80 to 120 km. The DGE nodes allow gain equalization in long haul networks over 1200 km.

This topology uses terminal, OLA, and DGE nodes.

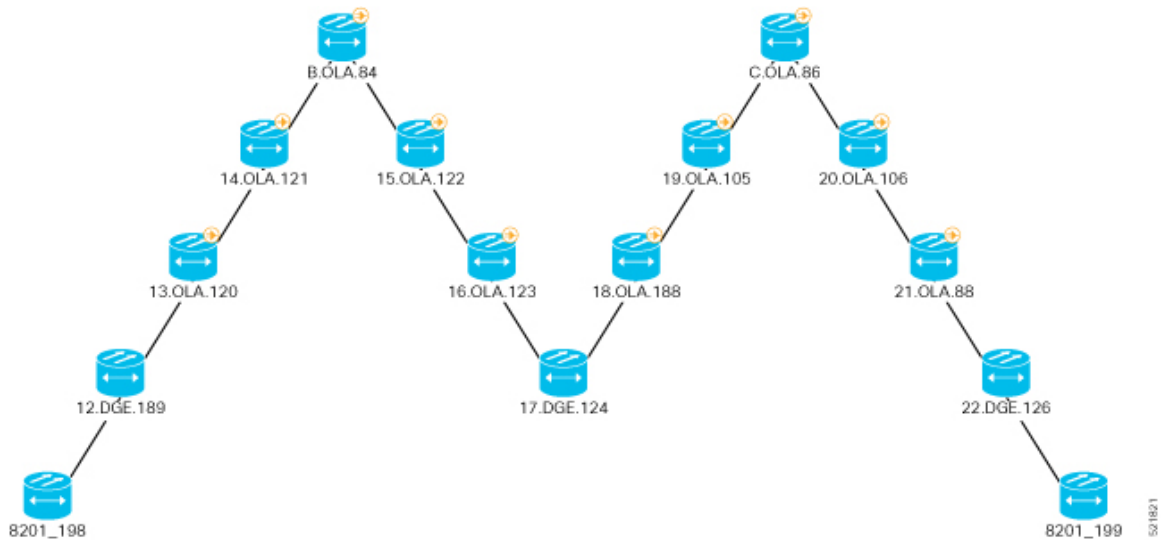
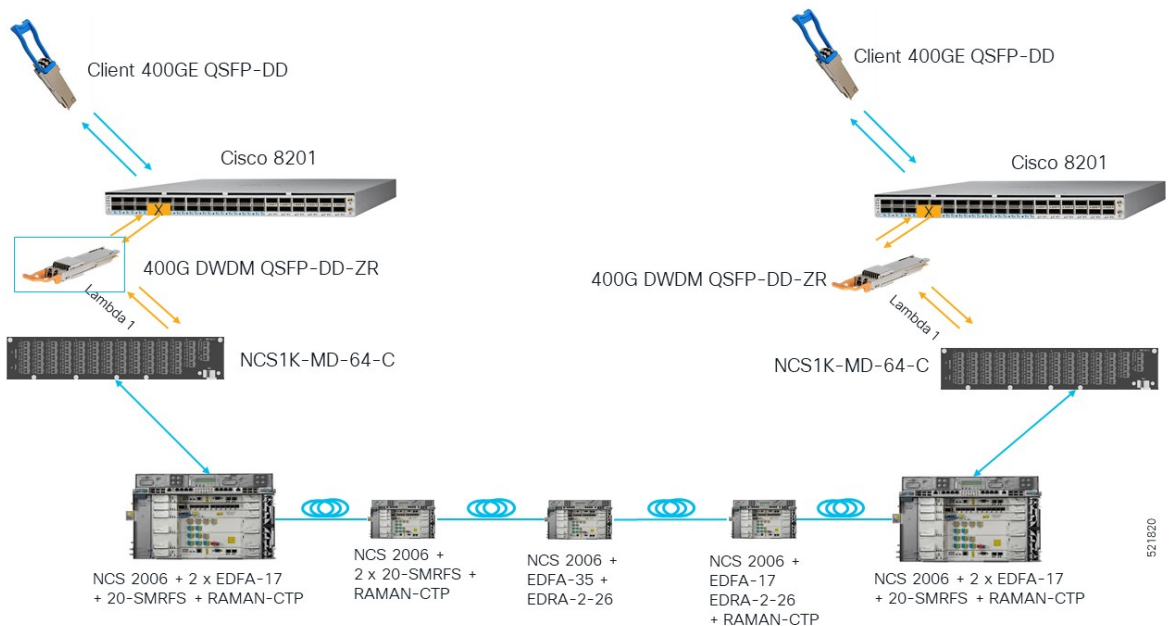
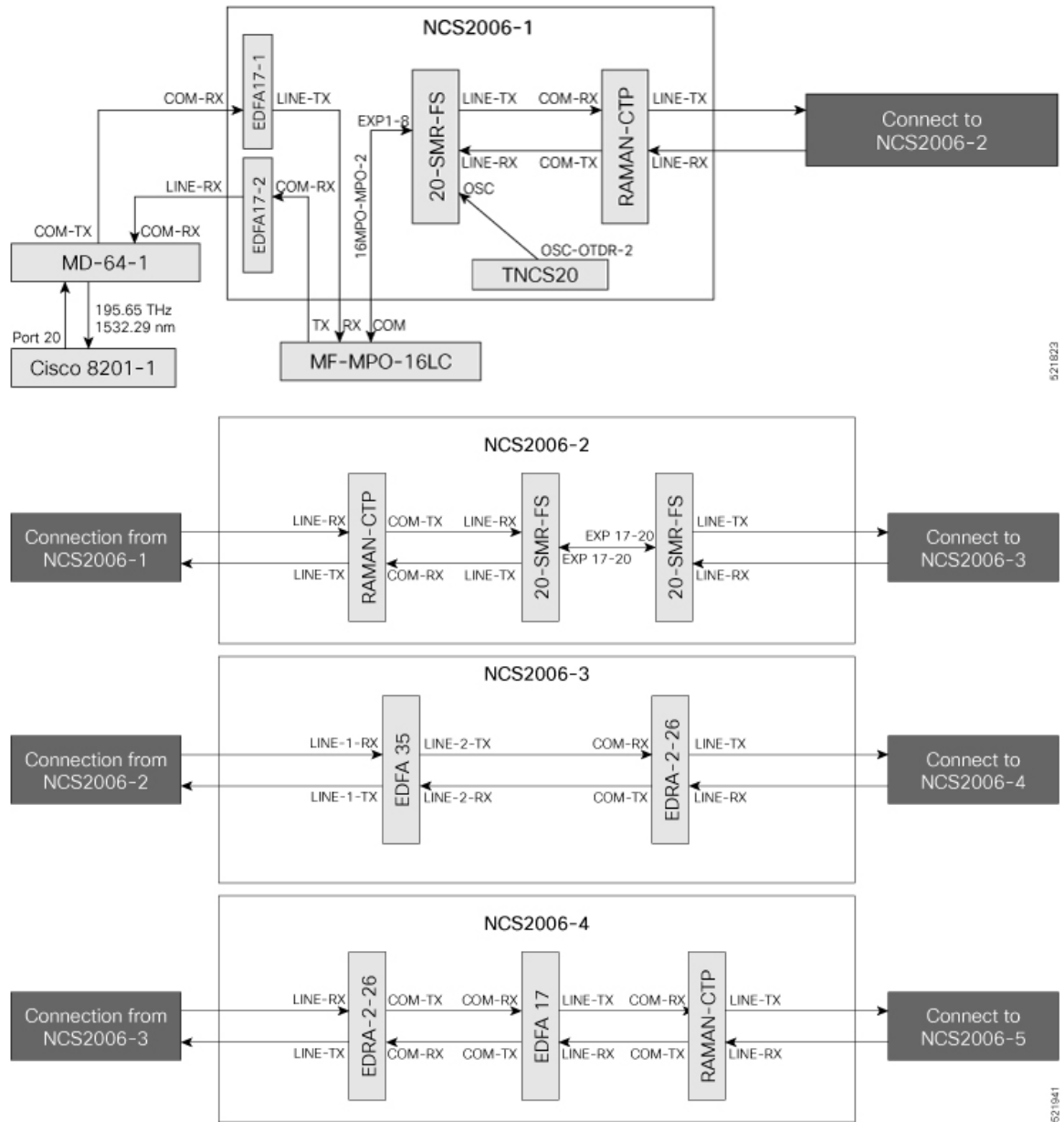

Figure 14: 400G-ZR P2P Long Haul Applications with Cisco NCS 2006



This diagram displays the wiring diagram for the long haul topology:

Figure 15: Wiring Diagram for a Long Haul Topology



521923

521941

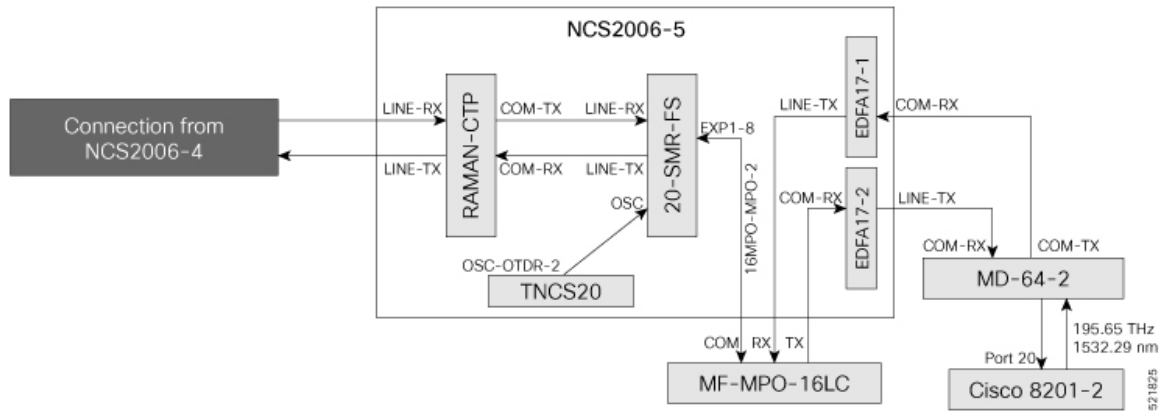

In this sample topology, Cisco 8201-1 is the source router, and Cisco 8201-2 is the destination router.

Topology Components

To build this topology, you need the following hardware:

- Cisco 8200 Series Routers
- NCS1K-MD-64-C Modules
- Cisco NCS 2006
- TNCS-20 Cards
- OPT-EDFA-17 Cards
- EDRA-2-26 cards
- RAMAN-CTP Cards
- SMR20 FS Cards
- MF-MPO-16LC passive modules (seated in an NCS2K-MF-1RU mechanical frame)
- QDD-400G-ZR-S transceiver
- LC/LC cables
- 16MPO-MPO-2 cables

For more information, see [Hardware Components, on page 11](#).

Port Connections

To build this topology, connect the cables in the following sequence:

1. On the Cisco 8201-1 and Cisco 8201-2 routers:
 - a. Align the QDD-400G-ZR-S transceiver module in front of the transceiver socket opening in Port 20. Then, carefully slide the transceiver into the socket until the transceiver comes in contact with the socket electrical connector.
 - b. Holding the pull-tab, seat the transceiver in the module's transceiver socket fully until it clicks.
 - c. Attach an LC/LC fiber immediately to the QDD-400G-ZR-S transceiver module.

20. Connect an LC/LC fiber from the LINE-RX port of the EDRA-2-26 card (NCS 2006-3) to the LINE-TX port of the EDRA-2-26 card (NCS 2006 -4).
21. Connect an LC/LC fiber from the COM-TX port of the EDRA-2-26 card (NCS 2006-4) to the COM-RX port of the EDFA-17 card (NCS 2006 -4).
22. Connect an LC/LC fiber from the COM-RX port of the EDRA-2-26 card (NCS 2006-4) to the COM-TX port of the EDFA-17 card (NCS 2006 -4).
23. Connect an LC/LC fiber from the COM-RX port of the EDRA-2-26 card (NCS 2006-4) to the COM-TX port of the EDFA-17 card (NCS 2006 -4).
24. Connect an LC/LC fiber from the LINE-TX port of the EDFA-17 card (NCS 2006-4) to the COM-RX port of RAMAN-CTP card (NCS 2006-4).
25. Connect an LC/LC fiber from the LINE-RX port of the EDFA-17 card (NCS 2006-4) to the COM-TX port of RAMAN-CTP card (NCS 2006-4).
26. Connect an LC/LC fiber from the LINE-TX port of the RAMAN-CTP card (NCS 2006-4) to the LINE-RX port of RAMAN-CTP card (NCS 2006-5).
27. Connect an LC/LC fiber from the LINE-RX port of the RAMAN-CTP card (NCS 2006-4) to the LINE-TX port of RAMAN-CTP card (NCS 2006-5).
28. Connect an LC/LC fiber from the COM-TX port of the RAMAN-CTP card (NCS 2006-5) to the LINE-RX port of the 20-SMR-FS card (NCS 2006-5).
29. Connect an LC/LC fiber from the COM-RX port of the RAMAN-CTP card (NCS 2006-5) to the LINE-TX port of the SMR20 card (NCS 2006-5).
30. Connect an LC/LC fiber from the OSC-OTDR-2 port of the TNCS-2O card (NCS 2006 -5) to the OSC-TX port of the 20-SMR-FS card (NCS 2006 -5).
31. Connect a 16MPO-MPO-2 cable from the EXP1-8 port of the 20-SMR-FS card (NCS 2006-5) to the COM port of the MF-MPO-16LC module.
32. Connect an LC/LC fiber from the LINE-TX port of the EDFA-17-1 card (NCS 2006-5) to the RX port of the MF-MPO-16LC module.
33. Connect an LC/LC fiber from the COM-RX port of the EDFA-17-2 card (NCS 2006-5) to the TX port of the MF-MPO-16LC module.
34. Connect an LC/LC fiber from the COM-RX port of the EDFA17-1 card (NCS 2006-5) to the COM-TX port of the MD-64-2 module.
35. Connect an LC/LC fiber from the LINE-TX port of the EDFA-17-2 card (NCS 2006-5) to the COM-RX port of the MD-64-2 module.

Next Steps

After you complete building the topology, perform the following steps:

- [Import the Cisco ONP Configuration File into SVO.](#)
- [Manage Expected Input Power](#)



CHAPTER 5

Automation Workflows

This chapter describes the installation and communication sequence of the Routed Optical Networking components. The chapter also includes some Routed Optical Networking ML service provisioning examples.

- [Sequence for Installation of Routed Optical Networking Components, on page 41](#)
- [Communication Sequence, on page 42](#)
- [Service Provisioning Examples, on page 44](#)
- [Crosswork Hierarchical Controller Provisioning Workflow, on page 49](#)
- [Troubleshoot Provisioning Issues, on page 49](#)

Sequence for Installation of Routed Optical Networking Components

We recommend this installation sequence:



Note Cisco Crosswork Network Controller (Crosswork Optimization Engine, CAT) and Cisco Optical Network Controller are the minimum required components for the Routed Optical Networking solution.

- Install Cisco Optical Network Planner. Cisco Optical Network Planner is used to determine the optical layer feasibility and components used to support the network. A BoM is generated for hardware to be utilized in the planned deployment. For more information, see [Cisco Optical Network Planner Installation Guide](#).
- Install the router and optical hardware as specified in the network design. Complete the physical wiring between all the components. For more information see, [Deployment Topologies, on page 29](#).
- Install SVO to manage the NCS 2000 optical components. Create SVO instances to manage NCS 2000 devices. For more information, see [Cisco NCS 2000 Series SVO Configuration Guide, Release 12.2](#).
- Install the Crosswork Infrastructure 4.0, Crosswork Data Gateway, and supporting Crosswork Network Controller 3.0 applications (Crosswork Optimization Engine, CAT, Hi). For more information, see [Cisco Crosswork Infrastructure 4.1 and Applications Installation Guide](#).
- Install Cisco Optical Network Controller 1.1. For more information, see [Cisco Optical Network Controller 1.1 Configuration Guide](#).

- Install EPNM 5.1.3. EMS to manage the physical router and the optical network nodes. For more information, see *Installation Guide for Cisco Evolved Programmable Network Manager 5.1*.
- Install Cisco NSO 5.5.2.9, Routed Optical Networking Multi-layer Function Pack 1.0, and Crosswork DLM function pack. Optionally, install the Cisco Transport SDN Function pack for SR-TE and xVPN service management. For more information, see the [Cisco Network Services Orchestrator Installation Guide](#), [Cisco NSO Routed Optical Networking Core Function Pack Installation Guide](#), [Cisco NSO Transport-SDN Function Pack Bundle User Guide 3.0](#), [Cisco NSO Transport-SDN Function Pack Bundle User Guide 4.0](#), [Cisco Network Services Orchestrator DLM Service Pack Installation Guide 4.1.0](#).
- Add SVO devices to Cisco Optical Network Controller for the optical service management. For more information, see [Cisco Optical Network Controller 1.1 Configuration Guide](#).
- Install SR-PCE in the network for SR-TE or RSVP-TE discovery and visualization.
- Add NSO, SR-PCE, and Cisco routers to the Crosswork cluster. For more information, see [Add Cisco NSO Providers](#), [Add Cisco SR-PCE Providers](#), [Adding Devices to Inventory](#).

Add the Cisco Optical Network Controller instance as a device in NSO to support end-to-end multi-layer provisioning. For more information, see the *Cisco NSO Routed Optical Networking Core Function Pack User Guide*.

Communication Sequence

This diagram displays the communication sequence between the Routed Optical Networking components:

Figure 16: Routed Optical Networking Communication Flow

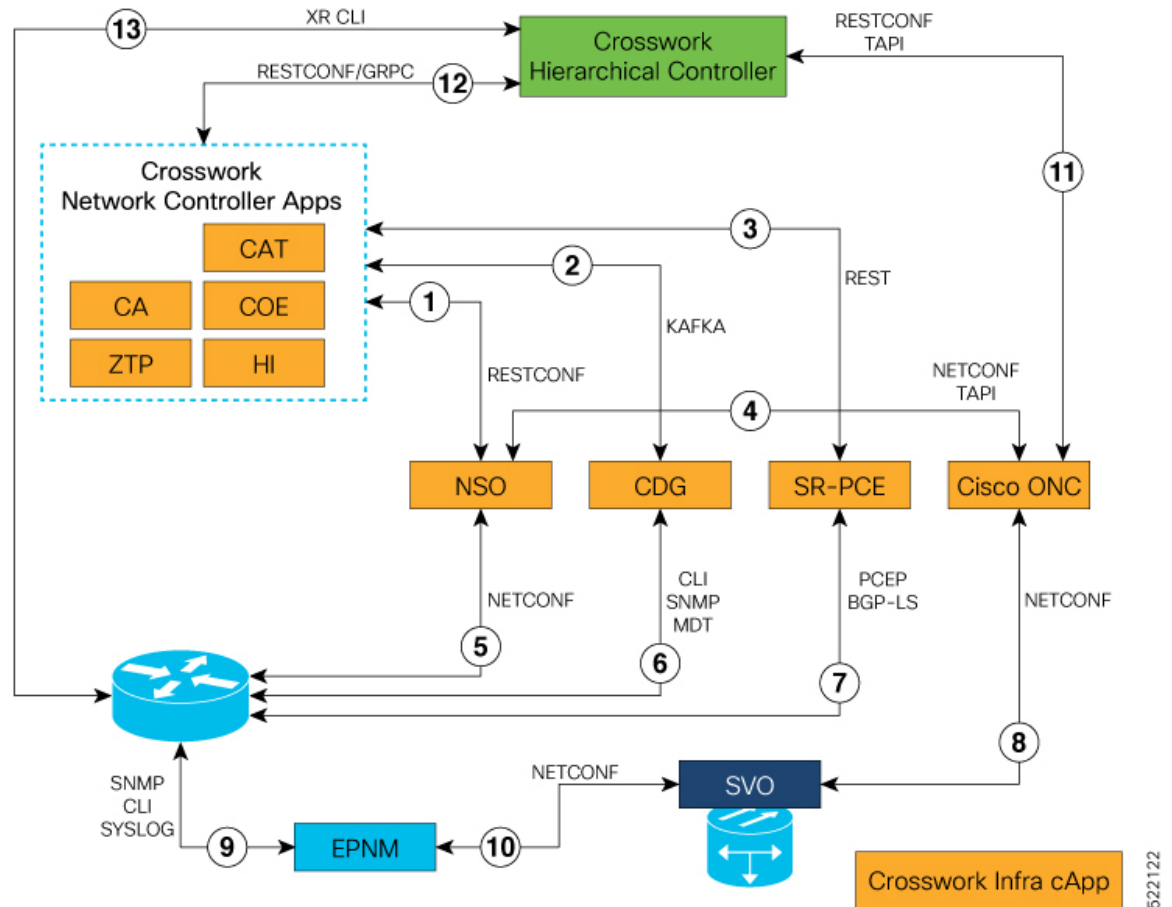

1. Crosswork Network Controller discovers services. Crosswork Network Controller populates NSO with device information via RESTCONF and handles NSO provisioning requests. EMS collects fault and alarm data from devices.
2. Crosswork Data Gateway sends device status to Crosswork Network Controller using Kafka. Crosswork Network Controller manages the Crosswork Data Gateway instance.
3. SR-PCE sends SR-TE/RSVP-TE and topology information to Crosswork Network Controller via REST APIs.
4. NSO discovers information from Cisco Optical Network Controller and provisions to Cisco Optical Network Controller via NETCONF TAPI.
5. NSO manages XR router configuration using NETCONF.
6. Crosswork Data Gateway collects network information from XR routers using CLI, SNMP, and MDT.
7. SR-PCE acts as a network PCE and collects IGP topology information from the network using PCEP and BGP-LS.
8. Cisco Optical Network Controller manages the SVO and NCS 1010 network nodes via NETCONF and gNMI. Cisco Optical Network Controller communicates with Cisco Optical Site Manager for NCS 1010

9. EPNM performs router inventory, SWIM, fault, and performance data collection using SNMP, CLI, and SYSLOG.
10. EPNM performs optical inventory, SWIM, fault, and performance data collection via NETCONF.
11. Crosswork Hierarchical Controller discovers optical equipment, topology, and services and provisions optical services via TAPI. Crosswork Hierarchical Controller receives PM data using ONC RPC.
12. Crosswork Hierarchical Controller discovers IGP nodes and topology and provisions services using Crosswork Network Controller NB API. Crosswork Hierarchical Controller receives PM data using GRPC.
13. Crosswork Hierarchical Controller collects the inventory data for ZR/ZR+ optics discovery using XR adapter directly from routers. This is also used to verify successful provisioning.



Note Routed Optical Networking components are not required in all the deployments.

Service Provisioning Examples

In this section, two service provisioning examples have been provided. These examples use the Cisco NSO Routed Optical Networking Core Function Pack for service provisioning. The examples are:

In this section, a service provisioning example has been provided. This example uses the Cisco NSO Routed Optical Networking Core Function Pack for service provisioning.

- Cisco routers with ZR or ZR+ transceivers and NCS 2000 optical devices.
- Cisco routers with ZR or ZR+ transceivers only. This example does not involve optical provisioning.

Provision End-to-end Service (Cisco Routers with ZR/ZR+ Optics and NCS 2000 Devices)

These diagrams display a network that contains Cisco routers with ZR or ZR+ optics and NCS 2000 devices.

Figure 17: Cisco Routers (with ZR/ZR+ Optics) and NCS 2000 Devices

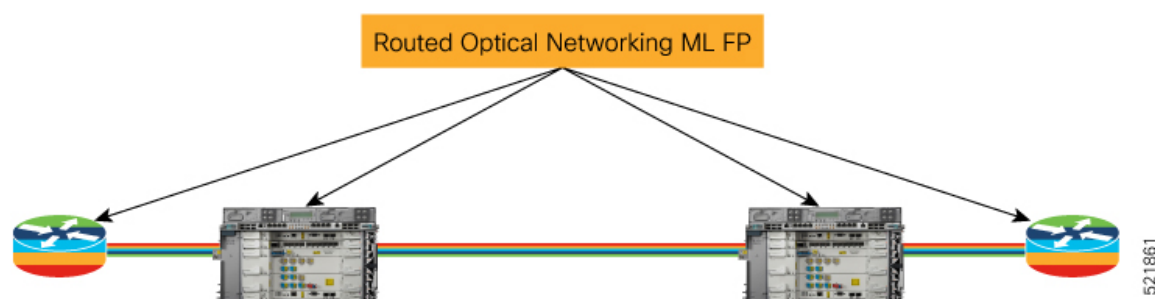

521861

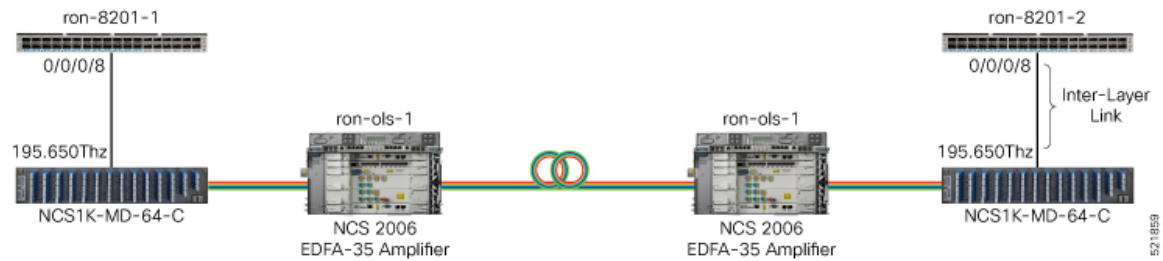

1. Define the inter-layer links.

```

ron inter-layer-link ron-8201-1 0/0/0/8
  site "Los Angeles"
  ols-domain network-element ron-ols-1
  ols-domain optical-add-drop 1/2007/1/18,17
  ols-domain optical-controller onc-cw-100
!
ron inter-layer-link ron-8201-2 0/0/0/8
  site Phoenix
  ols-domain network-element ron-ols-2
  ols-domain optical-add-drop 1/2007/1/18,17
  ols-domain optical-controller onc-cw-100
!

```



Note The add drop port on ron-ols-1 in R/S/L/P format is 1/2007/1/17,18. Two ports are configured for both RX and TX but a single port can also be given.

In the function pack, the network-element and optical-add-drop is converted into the TAPI inventory format.

```
ron-ols-1 and 1/2007/1/18,17 = /ne=ron-ols-1/r=1/sh=2007/sl=1/s_sl=0/p=18,17
```

2. Create Routed Optical Networking ML service with following parameters:

Input	Value
End-points	ron-8201-1, ron-8201-2
Model	Transponder (1x400G mode)
Bandwidth	400G
Frequency	Supplied by Cisco Optical Network Controller. This value may be user defined too.
TX Power	Supplied by Cisco Optical Network Controller. This value may be user defined too.
IP Addressing	10.2.1.10/31 and 10.2.1.11/31 on FourHundredGigE 0/0/0/8

```

ron ron-ml ron-8201-1_ron-8201-2
  mode transponder
  bandwidth 400
  ols-domain service-state UNLOCKED
  end-point ron-8201-1
  terminal-device-optical line-port 0/0/0/8

```

```

ols-domain end-point-state UNLOCKED
terminal-device-packet interface 0
  ip-address v4 10.2.1.10/31
!
!
end-point ron-8201-2
terminal-device-optical line-port 0/0/0/8
ols-domain end-point-state UNLOCKED
terminal-device-packet interface 0
  ip-address v4 10.2.1.11/31
!
!
!

```

NSO Routed Optical Networking ML Service

This diagram displays the NSO Routed Optical Networking ML service workflow for an end-to-end service (Cisco routers with ZR/ZR+ optics and NCS 2000 devices).

Figure 18: NSO Routed Optical Networking ML Service Sequence

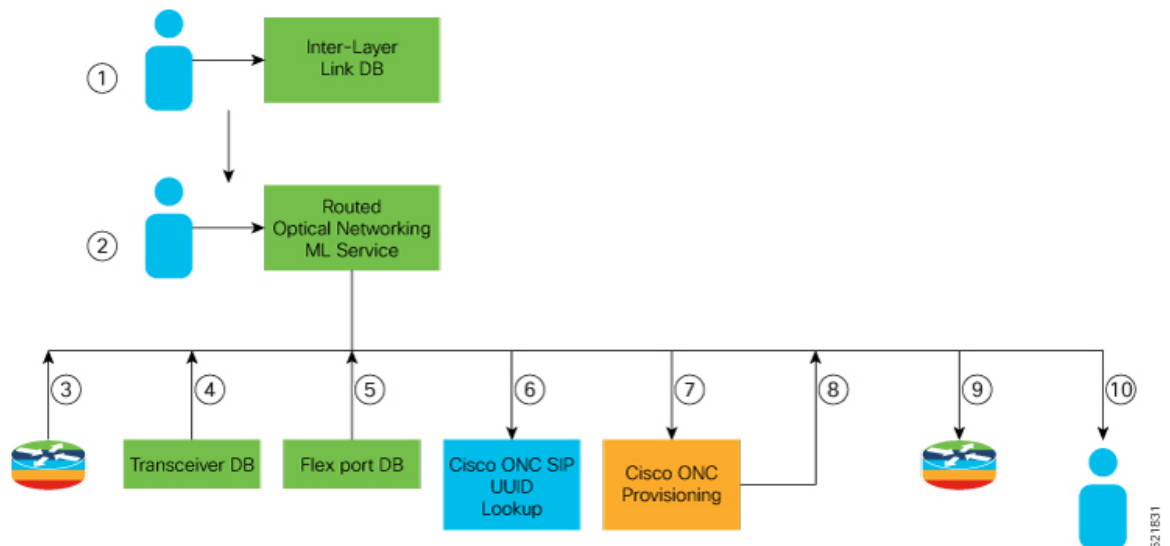

The workflow of the Routed Optical Networking ML service is as follows:

1. User populates the inter-Layer link DB for each router end-point.
2. User initiates the Routed Optical Networking ML provisioning request.
3. The Routed Optical Networking ML service retrieves the transceiver and line card PIDs for each router end-point using Cisco YANG models.
4. The Routed Optical Networking ML service compares the received transceiver PIDs and determines if the transceivers can support the service.
5. The Routed Optical Networking ML service compares the received line card PIDs, and determines if the line cards need to be configured.
6. If there is no explicit SIP UUID, the Routed Optical Networking ML service performs a lookup for the SIP via the Optical Network Controller TAPI using the INVENTORY_ID.

7. The Routed Optical Networking ML service sends a TAPI connectivity-service request to Optical Network Controller for optical provisioning using SIPs and ZR/ZR+ application IDs.
8. Cisco Optical Network Controller returns the state after the provisioning is complete. Cisco Optical Network Controller optionally returns the wavelength and TX power if these parameters are not user-defined.
9. The Routed Optical Networking ML service provisions the router optics ports. It optionally performs bundle and IP configuration using the Cisco YANG models.
10. The Routed Optical Networking ML service stores the service information as NSO operational data and also returns the service state to user.

Provision End-to-end Service (Cisco Routers with ZR/ZR+ Optics Only)

These diagrams display a network that contains Cisco routers with ZR or ZR+ optics and a non-Cisco optical line system.

Figure 19: Cisco Routers (with ZR/ZR+ Optics)

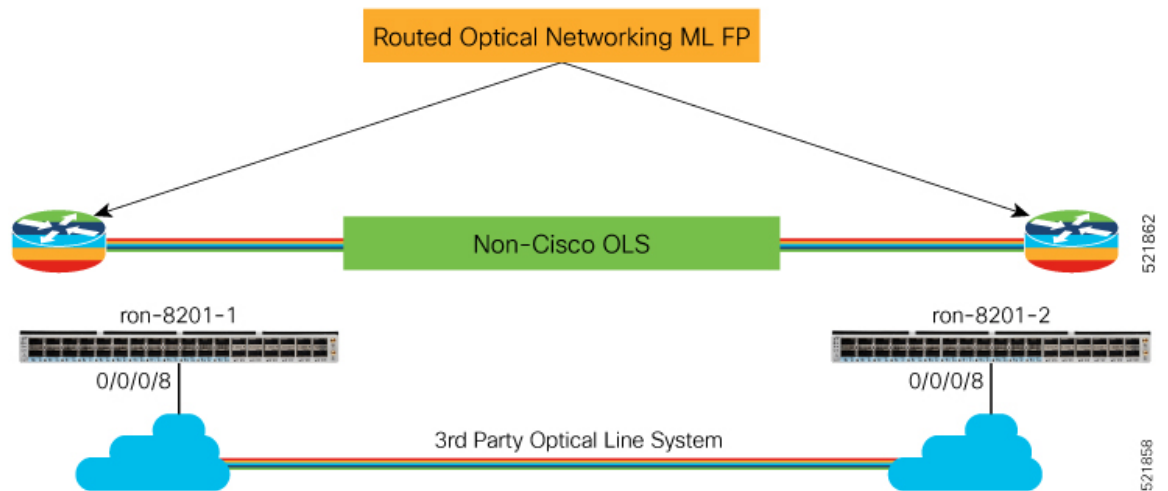

1. Create Routed Optical Networking ML Service with the following parameters:

Input	Value
End-points	ron-8201-1, ron-8201-2
Model	Transponder (1x400G mode)
Bandwidth	400G
Frequency	1952000
TX Power	-12dB on both endpoints
IP Addressing	10.2.1.10/31 and 10.2.1.11/31 on FourHundredGigE 0/0/0/8

```
ron ron-ml ron-8201-1_ron-8201-2
mode transponder
bandwidth 400
```

```

circuit-id "Router Only"
frequency 1952000
end-point ron-8201-1
  terminal-device-optical line-port 0/0/0/8
  terminal-device-optical transmit-power -120
  terminal-device-packet interface 0
  ip-address v4 10.2.1.10/31
  !
!
end-point ron-8201-2
  terminal-device-optical line-port 0/0/0/8
  terminal-device-optical transmit-power -120
  terminal-device-packet interface 0
  ip-address v4 10.2.1.11/31
  !
!
!

```

NSO Routed Optical Networking ML Service

This diagram displays the NSO Routed Optical Networking ML service workflow for an end-to-end service (only Cisco routers with ZR/ZR+ optics).

Figure 20: NSO Routed Optical Networking ML Service Sequence

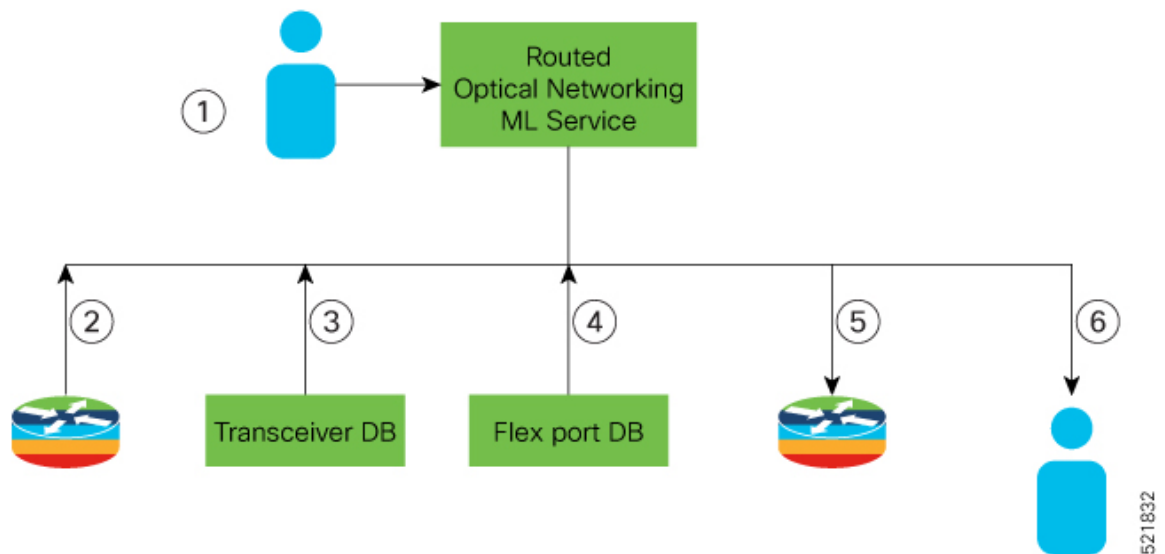

The workflow of the Routed Optical Networking ML service is as follows:

1. User initiates the Routed Optical Networking ML provisioning request.
2. The Routed Optical Networking ML service retrieves the transceiver and line card PIDs for each router end-point using Cisco native YANG models.
3. The Routed Optical Networking ML service compares the received transceiver PIDs and determines if the transceivers can support the service.
4. The Routed Optical Networking ML service compares the received line card PIDs, and determines if the line cards must be configured.

5. The Routed Optical Networking ML service provisions the router optics ports. It optionally performs bundle and IP configuration using the Cisco YANG models.
6. The Routed Optical Networking ML service stores the service information as NSO operational data and also returns the service state to user.

Crosswork Hierarchical Controller Provisioning Workflow

This section describes the workflow for provisioning the Routed Optical Networking circuit in the Crosswork Hierarchical Controller GUI via the Crosswork Network Controller.



Note The workflow does not support provisioning an end-to-end service in a network that contains Cisco routers with ZR or ZR+ optics and a non-Cisco optical line system.

Figure 21: Crosswork Hierarchical Controller Provisioning Workflow

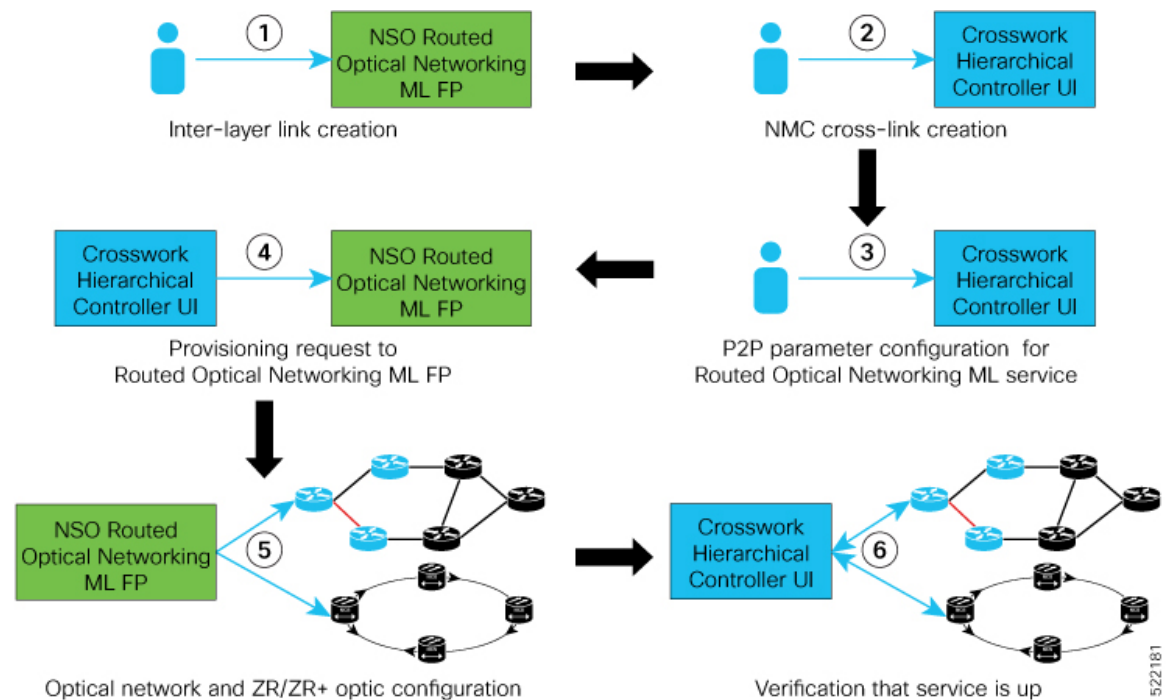

Troubleshoot Provisioning Issues

Provisioning on ZR or ZR+ Optics

- To check the controller state on the router, use:

```
RP/0/RP0/CPU0:ron-8201-1#show controllers optics 0/0/0/20
Thu Jun  3 15:34:44.098 PDT
```

Controller State: Up

Transport Admin State: In Service

Laser State: On

LED State: Green

FEC State: FEC ENABLED

Optics Status

Optics Type: QSFPDD 400G ZR
 DWDM carrier Info: C BAND, MSA ITU Channel=10, Frequency=195.65THz,
 Wavelength=1532.290nm

Alarm Status:

Detected Alarms: None

LOS/LOL/Fault Status:

Alarm Statistics:

HIGH-RX-PWR = 0	LOW-RX-PWR = 0
HIGH-TX-PWR = 0	LOW-TX-PWR = 4
HIGH-LBC = 0	HIGH-DGD = 1
OOR-CD = 0	OSNR = 10
WVL-OOL = 0	MEA = 0
IMPROPER-REM = 0	
TX-POWER-PROV-MISMATCH = 0	
Laser Bias Current = 0.0 %	
Actual TX Power = -7.17 dBm	
RX Power = -9.83 dBm	
RX Signal Power = -9.18 dBm	
Frequency Offset = 9 MHz	

RP/0/RP0/CPU0:ron-8201-1#show controllers coherentDSP 0/0/0/20

Thu Jun 3 15:38:04.565 PDT

```

Port                               : CoherentDSP 0/0/0/20
Controller State                    : Up
Inherited Secondary State           : Normal
Configured Secondary State         : Normal
Derived State                       : In Service
Loopback mode                       : None
BER Thresholds                      : SF = 1.0E-5  SD = 1.0E-7
Performance Monitoring              : Enable
Bandwidth                           : 400.0Gb/s

```

Alarm Information:

```

LOS = 8  LOF = 0  LOM = 0
OOF = 0  OOM = 0  AIS = 0
IAE = 0  BIAE = 0      SF_BER = 0
SD_BER = 0      BDI = 0  TIM = 0
FECMISMATCH = 0  FEC-UNC = 0  FLEXP_GIDM = 0
FLEXP-MM = 0    FLEXP-LOM = 0  FLEXP-RDI = 0
FLEXP-LOF = 2
Detected Alarms                    : None

```

Bit Error Rate Information

```

PREFEC BER                          : 1.5E-03

```

```

POSTFEC BER : 0.0E+00
Q-Factor    : 9.40 dB

Q-Margin      : 2.20dB

OTU TTI Received

FEC mode    : C_FEC

```

- To gather the performance measurement data, use:

```

RP/0/RP0/CPU0:ron-8201-1#show controllers optics 0/0/0/20 pm current 30-sec optics 1
Thu Jun 3 15:39:40.428 PDT

```

Optics in the current interval [15:39:30 - 15:39:40 Thu Jun 3 2021]

Optics current bucket type : Valid

Configured TCA	MIN	AVG	MAX	Operational Th(min)	Configured TCA Th(min)	Operational Th(max)
Th(max) (max)						
LBC[%]	0.0	0.0	0.0	0.0	NO	100.0
OPT[dBm]	-7.17	-7.17	-7.17	-15.09	NO	0.00
OPR[dBm]	-9.86	-9.86	-9.85	-30.00	NO	8.00
CD[ps/nm]	-489	-488	-488	-80000	NO	80000
DGD[ps]	1.00	1.50	2.00	0.00	NO	80.00
SOPMD[ps^2]	28.00	38.80	49.00	0.00	NO	2000.00
OSNR[dB]	34.90	35.12	35.40	0.00	NO	40.00
PDL[dB]	0.70	0.71	0.80	0.00	NO	7.00
PCR[rad/s]	0.00	0.00	0.00	0.00	NO	2500000.00
RX_SIG[dBm]	-9.23	-9.22	-9.21	-30.00	NO	1.00
FREQ_OFF[Mhz]	-2	-1	4	-3600	NO	3600
SNR[dB]	16.80	16.99	17.20	7.00	NO	100.00

```

RP/0/RP0/CPU0:ron-8201-1#show controllers coherentDSP 0/0/0/20 pm current 30-sec fec
Thu Jun 3 15:42:28.510 PDT

```

g709 FEC in the current interval [15:42:00 - 15:42:28 Thu Jun 3 2021]

FEC current bucket type : Valid

```

EC-BITS : 20221314973          Threshold : 83203400000          TCA(enable)
: YES
UC-WORDS : 0                  Threshold : 5                    TCA(enable)
: YES

```

	MIN	AVG	MAX	Threshold (min)	TCA (enable)	Threshold (max)	TCA (enable)
PreFEC BER	1.5E-03	1.5E-03	1.6E-03	0E-15	NO	0E-15	NO
PostFEC BER	E-15	0E-15	0E-15	0E-15	NO	0E-15	NO
Q[dB]	9.40	9.40	9.40	0.00	NO	0.00	NO
Q_Margin[dB]	2.20	2.20	2.20	0.00	NO	0.00	NO

Last clearing of "show controllers OTU" counters never

This table contains the streaming telemetry sensor paths and the information fields that you receive from them.

Sensor path	Information Fields
Cisco-IOS-XR-controller-optics-oper:optics-oper/optics-ports/optics-port/optics-info	alarm-detected, baud-rate, dwdm-carrier-frequency, controller-state, laser-state, optical-signal-to-noise-ratio, temperature, voltage
Cisco-IOS-XR-controller-optics-oper:optics-oper/optics-ports/optics-port/optics-lanes/optics-lane	receive-power, receive-signal-power, transmit-power
Cisco-IOS-XR-controller-otu-oper:otu/controllers/controller/info	bandwidth, ec-value, post-fec-ber, pre-fec-ber, qfactor, qmargin, uc
Cisco-IOS-XR-pmengine-oper:performance-management/optics/optics-ports/optics-port/optics-current/optics-second30/optics-second30-optics/optics-second30-optic	dd_average, dgd_average, opr_average, opt_average, osnr_average, pcr_average, pmd_average, rx-sig-pow_average, snr_average, sopmd_average
Cisco-IOS-XR-pmengine-oper:performance-management/otu/otu-ports/otu-port/otu-current/otu-second30/otu-second30fec/otu-second30fec	ec-bits_data, post-fec-ber_average, pre-fec-ber_average, q_average, qmargin_average, uc-words_data



Note The performance management sensor paths show the sensor path for a 30-second performance measurement (PM) interval. They also support 15 minutes and 24 hours. To access these options, replace `second30` in the sensor path with `minute15` and `hour24` respectively.

NSO Provisioning

The following figure displays a successful provisioning scenario.

Figure 22: **

```
admin@ncs# show ron ron-ml-plan 030f63ab_84fb_4ff1_9871_6c1421f99b0f
```

TYPE	NAME	BACK TRACK	GOAL	STATUS CODE	STATE	STATUS	WHEN	POST ACTION
self	self	false	-	RON-200	init	reached	2021-06-11T16:47:25	create-reached
optical-controller	Optical-Controller	false	-	RON-200	init	reached	2021-06-11T16:47:53	-
					ready	reached	2021-06-11T16:47:30	-
cisco-ron-cfp-nano-plan-services:router	ron-8201-1	false	-	RON-200	init	reached	2021-06-11T16:47:30	-
					ready	reached	2021-06-11T16:47:47	-
cisco-ron-cfp-nano-plan-services:router	ron-8201-2	false	-	RON-200	init	reached	2021-06-11T16:47:47	-
					ready	reached	2021-06-11T16:47:53	-
cisco-ron-cfp-nano-plan-services:router	ron-8201-2	false	-	RON-200	init	reached	2021-06-11T16:47:47	-
					ready	reached	2021-06-11T16:47:47	-

522172

The following figure displays a failed provisioning scenario, due to an error in the Cisco Optical Network Controller provisioning.

```
admin@ncs# show ron ron-ml-plan ron_poc_demo_195200 plan
```

TYPE	NAME	BACK TRACK	GOAL	STATUS CODE	STATE	STATUS	WHEN	ref	POST ACTION STATUS
self	self	false	-	RON-304	init	reached	2021-06-13T15:32:32	-	create-reached
optical-controller	Optical-Controller	false	-	RON-304	init	failed	2021-06-13T15:32:32	-	-
cisco-ron-cfp-nano-plan-services:router	ron-poc-8201-1	false	-	-	ready	reached	2021-06-13T15:32:32	-	-
cisco-ron-cfp-nano-plan-services:router	ron-poc-8201-2	false	-	-	ready	reached	2021-06-13T15:32:32	-	-
					init	not-reached	-	-	-
					cisco-ron-cfp-nano-plan-services:config-apply	not-reached	-	-	-
					ready	not-reached	-	-	-
					init	not-reached	-	-	-
					cisco-ron-cfp-nano-plan-services:config-apply	not-reached	-	-	-
					ready	not-reached	-	-	-

522171

Crosswork Hierarchical Controller Provisioning

In the event of a failed configuration, the configuration state transitions to FAILED. The Last Operation is in the **Rollback** stage where it rolls back the configuration.

Figure 23: Crosswork Hierarchical Controller UI - Operations Tab

The screenshot displays the 'Operations' tab for a service named 'ron-8201-1_FourHundredGigE0/0/18_to_ron-ncs57b1-1_FourHundredGigE0/0/24_1635193658342'. The table below shows the configuration details:

Name	FPF Type	Configuration State	Creation Date	Endpoint A	Endpoint B	Speed (Gbps)	Operational State	Last 2M Operations	Last Operation
ron-8201-1_FourHundredGigE0/0/18_to_ron-ncs57b1-1_FourHundredGigE0/0/24_1635193658342	IP Link	FAILED	25-10-2021 20:28:22 UTC	FourHundredGigE0/0/24 100.18.18.1...	FourHundredGigE0/0/18 100.18.18.18/31	400	I		Rollback Create IP Link ✓ Done

The 'Operations' tab shows a single action: 'Create IP Link' with a lifecycle state of 'Rollback ✓ Done'. The 'Errors' tab is active, displaying the following error message:

```

[25-10-2021 20:34:00 UTC] Discovery took too long
Full error message:
Discovery took too long

```

522178

After clicking the service, you can click on ERRORS to check the reason for failure. In this case, the discovery of the operational state exceeded the discovery timeout. The reason for this is, one end of the link was in a loopback state, which did not prohibit the provisioning of the ports, but affected the reachability between the two endpoints.

Figure 24: Crosswork Hierarchical Controller UI - Operations Tab

The screenshot shows the 'Errors' tab for the same service. The error message is displayed as follows:

```

[25-10-2021 20:34:00 UTC] Discovery took too long
Full error message:
Discovery took too long

```

522179

The logs display both the provisioning flow and the rollback flow.

Figure 25: Crosswork Hierarchical Controller UI - Operations Tab

The screenshot displays the 'Operations' tab in the Crosswork Hierarchical Controller UI. The top navigation bar includes 'Summary', 'Endpoints', 'Underlay Path', 'Operations', 'Events', and 'Actions'. The main content area is divided into two sections: a table of operations and a detailed view of the current operation's flow.

Action	Lifecycle State	Creation Date	Last Update
ITEM			
Create IP Link	Rollback ✓ Done	25-10-2021 20:28:22 UTC	25-10-2021 20:34:08 UTC

The detailed view on the right shows the following flow steps:

- Normal Flow**
 - Adapter #1: cnc30 ✓
 - create ip-link
 - create ip-link response
- Rollback Flow**
 - Adapter #1: cnc30 ✓
 - delete ip-link
 - delete ip-link response

At the bottom of the interface, there are three tabs: 'SUMMARY', 'LOGS', and 'ERRORS'. The 'LOGS' tab is currently selected.

522180



APPENDIX **A**

Sample End-to-end Configuration

This appendix describes an end-to-end provisioning example for a Routed Optical Networking topology.

