



Provision PSM Cards

This chapter describes the PSM card used in Cisco NCS 2000 SVO and its related tasks.

Table 1: Feature History

Feature Name	Release Information	Feature Description
PSM	Cisco NCS 2000 Release 12.3	The PSM card performs splitter protection functions and supports the standalone protection configuration. The card provides channel protection for the 100G-LC-C, 100G-CK-C, 100GS-CK-LC, 200G-CK-C, and 400G-XP-LC cards. It also provides channel protection for alien wavelengths.

This table lists the package support for the PSM card.

Card	SSON Package (12.xx-xxxx-xx.xx-S-SPA)	MSTP Package (12.xx-xxxx-xx.xx-L-SPA)
PSM	✓	✓

In this chapter, "PSM" refers to the 15454-PSM= card.

- [PSM Card, on page 1](#)
- [Provision the Card Mode on the PSM Card, on page 4](#)
- [Provision Interface Parameters, on page 4](#)
- [Provision Optics Thresholds, on page 6](#)
- [Provision Optical Safety , on page 7](#)
- [View Insertion Loss Parameters, on page 9](#)
- [Manage the Protection Group, on page 9](#)

PSM Card

The PSM card performs splitter protection functions. In the transmit (TX) section of the PSM card, the signal received on the common receive port is duplicated by a hardware splitter to both the working and protect transmit ports. In the receive (RX) section of the PSM card, a switch is provided to select one of the two input signals (on working and protect receive ports) to be transmitted through the common transmit port.

The PSM card supports the Standalone protection configuration. The card provides channel protection for the 100G-LC-C, 100G-CK-C, 100GS-CK-LC, 200G-CK-C, and 400G-XP-LC cards. It also provides channel protection for alien wavelengths.

The PSM card is a single-slot card that can be installed in any service slot in the NCS 2006 and NCS 2015 chassis. The PSM card includes six LC-PC-II optical connectors on the front panel. In channel protection configuration, the PSM card can be installed in a different shelf from its peer TXP/MXP card.

Key Features

The PSM card provides the following features:

- Operates over the C-band (wavelengths from 1529 nm to 1562.5 nm) and L-band (wavelengths from 1570.5 nm to 1604 nm) of the optical spectrum.
- Implements bidirectional revertive protection scheme.
- Supports automatic creation of a splitter protection group when the PSM card is provisioned.
- Supports switching priorities based on ITU-T G.873.1.
- Supports performance monitoring and alarm handling with settable thresholds.

PSM Bidirectional Switching

A VOA is equipped after the hardware splitter within the PSM card. The VOA implements bidirectional switching when there is a single fiber cut in a protection configuration involving two peer PSM cards. The following figure shows a sample configuration that explains the bidirectional switching capability of the PSM card.

Figure 1: PSM Bidirectional Switching

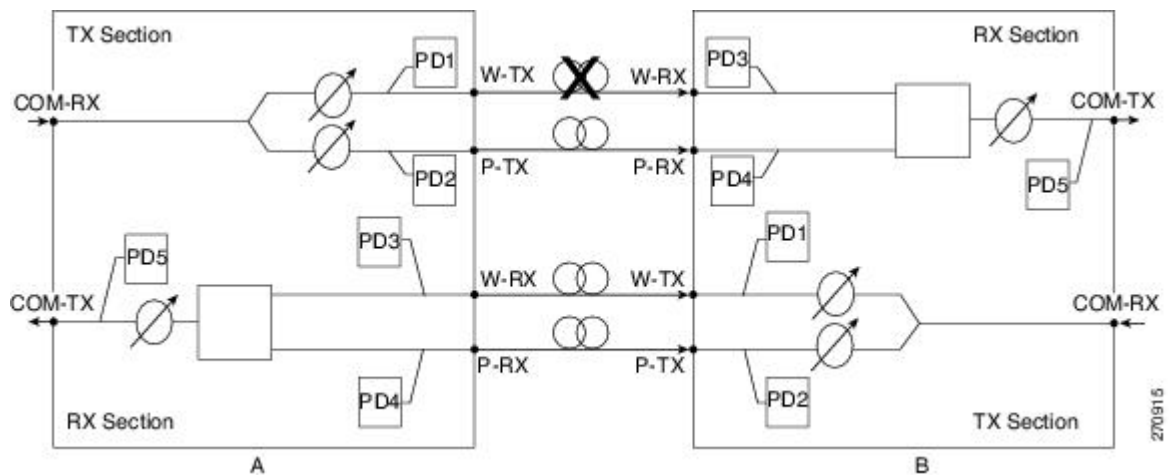

In this example, there is a fiber cut in the working path from Station A to Station B. As a result of the fiber cut, an LOS alarm is raised on the W-RX port of Station B and it immediately switches traffic on to its P-RX port. Station B simultaneously also stops transmission (for approximately 25 milliseconds) on its W-TX port, which raises an LOS alarm on the W-RX port of Station A. This causes Station A to also switch traffic to its P-RX port. In this way, PSM implements bidirectional switching without any data Exchange between the two stations.

Because the two stations do not communicate using signaling protocols (overhead bytes), a Manual or Force protection switch on the PSM card is implemented by creating a traffic hit. For example, consider that you perform a Manual or Force protection switch on Station A. The TX VOA on the active path is set to automatic VOA shutdown (AVS) state for 25 milliseconds. This causes Station B to switch traffic to the other path because it cannot differentiate between a maintenance operation and a real fail. After 25 milliseconds, the VOA in Station A is automatically reset. Now Station B does not revert back by itself if the non-revertive switching protection scheme is used in the PSM card. However, if the automatic reversion feature on the PSM card is enabled, Station B reverts back to the working path once Wait To Restore (WTR) timer is over.

To effectively implement switching, the Lockout and Force commands must be performed on both the stations. If these commands are not performed on both the stations, the far-end and near-end PSMs can be misaligned. In case of misalignment, when a path recovers, traffic might not recover automatically. You might have to perform a Force protection switch to recover traffic.



Note The order in which you repair the paths is important in the event of a double failure (both the working and protect paths are down due to a fiber cut) on the PSM card in line protection configuration when the active path is the working path. If you repair the working path first, traffic is automatically restored. However, if you repair the protect path first, traffic is not automatically restored. You must perform a Force protection switch to restore traffic on the protect path.

Automatic PSM Reversion

The PSM cards support automatic bidirectional switching. When the fault on the working path clears, traffic automatically switches from the protection path to the working path. The reversion takes place after the Wait To Restore (WTR) timer is over. The key features of automatic PSM reversion are:

- Only normal and standalone modes of PSM card support automatic reversion.
- Protection cannot be provisioned as revertive if automatic laser shutdown (ALS) is enabled in standalone mode, and vice versa.
- Revertive feature is supported for only OCH protection.
- By default, the protection in PSM is non-revertive.
- Reversion parameters that include revertive/non-revertive protection, WTR, pulse width, and interval can be configured only when the working path is active.
- WTR time can be set to a duration between one to 12 minutes and is configurable only if the protection is revertive. By default, the timer is set to five minutes.
- Reversion Pulse Width is between 10 to 200 seconds and is configurable only if the protection is revertive. By default, the duration is set to 60 seconds. This parameter value can be calculated using the following formula:

Minimum reversion pulse width = ROADM delay + 10 seconds

ROADM delay = $N \times 5 \times 2$

N=number of filter cards in the network between the source and destination PSM nodes on the working path.

5 = maximum startup delay in seconds

2=bidirectional communication

For example, if a network has four ROADM nodes with the end nodes having PSM cards on the working path as depicted below:

[PSM - Node 1 - FILTER 1] ===== [FILTER 2 - Node 2 - FILTER 3] ===== [FILTER 4 - Node 3 - FILTER 5] ===== [FILTER 6 - Node 4 - PSM]

then $N = 6$

ROADM delay = $6 \times 5 \times 2 = 60$

Minimum reversion pulse width = $60 + 10 = 70$ seconds

- Recovery Pulse Interval for reversion is auto-calculated and the user cannot configure the thresholds.

Provision the Card Mode on the PSM Card

Use this task to configure the card mode on the PSM card. There are two card modes available.

- PSM-NORMAL—Sets the PSM card in normal configuration. In this configuration, the PSM card supports channel protection, line protection, and multiplex section protection configurations.
- PSM-STANDALONE—Sets the PSM card in standalone configuration. In this configuration, the PSM card can be equipped in any slot and supports all node configurations.



Note In Release 12.3, only the PSM-STANDALONE card mode is supported. A PROV-MISMATCH alarm is raised if the PSM-NORMAL card mode is configured or an upgrade is performed with this operating mode from an earlier release.

Before you begin

- [Log into the SVO Web Interface](#)
- [Open the Card View](#)

Procedure

- Step 1** Click the **Provisioning > Card Mode** tabs.
- Step 2** Select the PSM-STANDALONE option from the **Mode** drop-down list.
- Step 3** Click **Apply**.

Provision Interface Parameters

Use this task to change the optical interface parameters of cards.

Before you begin

- [Log into the SVO Web Interface](#)
- [Open the Card View](#)

Procedure

Step 1 Click the **Provisioning** > **Interface** tabs.

Step 2 Modify the settings described in the following table. The provisionable parameters are listed in the Options column in the table.

Table 2: Interface Options

Parameter	Description	Options
Port	(Display only) Displays the port type and direction (RX or TX)	—
Admin State	Sets the administrative state of the port.	From the drop-down list, choose one of the following: <ul style="list-style-type: none"> • Unlocked (ETSI)/ IS (ANSI) • Locked, disabled (ETSI)/OOS, DSBLD (ANSI) • Locked, maintenance (ETSI)/OOS, MT (ANSI) • Unlocked, automaticInService (ETSI)/ IS, AINS (ANSI)
Service State	(Display only) Identifies the autonomously generated state that gives the overall condition of the port. Service states appear in the format: Primary State-Primary State Qualifier, Secondary State.	<ul style="list-style-type: none"> • IS-NR/ Unlocked-enabled • OOS-AU,AINS/ Unlocked-disabled, automaticInService • OOS-MA,DSBLD/ Locked-enabled,disabled • OOS-MA,MT/ Locked-enabled,maintenance
Optical Power (dBm)	Displays the optical power for each port.	—
OSC Power (dBm)	NA	—

Parameter	Description	Options
Optical PSD Setpoint (dBm/GHz)	NA	—
Attenuator Value (dB)	Sets the attenuator value.	—
Optical Power Threshold Low (dBm)	Fail low threshold used to detect the LOS alarm on the port.	—
OSC Power Threshold Low (dBm)	NA	—
Current Power Degrade High (dBm)	NA	—
Current Power Degrade Low (dBm)	NA	—
Current Power Failure Low (dBm)	(Display only) Shows the optical power failure low threshold for the port.	—
VOA Attenuation Setpoint (dB)	Sets the VOA attenuation value	0 to 25
VOA Attenuation Offset (dB)	Sets the offset with respect to the set setpoint	—
VOA Current Attenuation (dB)	(Display only) Shows the VOA current attenuation	—

Step 3 Click **Apply** to save the changes.

Provision Optics Thresholds

Use this task to configure the optics thresholds for the card.

Before you begin

- [Log into the SVO Web Interface](#)
- [Open the Card View](#)

Procedure

Step 1 Click the **Provisioning > Optics Thresholds** tabs.

Step 2 Choose the type of threshold that you want to change, 15 Min or 1 Day.

Step 3 Modify the settings described in the following table. The provisionable parameters are listed in the Options column in the table.

Table 3: Threshold Options

Parameter	Description	Options
Interface Name	(Display only) Displays the port type and direction (RX or TX)	—
PM Type	(Display only) Type of interface	<ul style="list-style-type: none"> • oscPowerPMTh • opticalPowerPMTh
Low	Sets the low power warning level.	Numeric. The default is -50 dBm. Double-click the parameter, enter a value, and press Enter.
High	Sets the high power warning level.	Numeric. The default is 30 dBm. Double-click the parameter, enter a value, and press Enter.

Step 4 Click **Apply** to save the changes.

Note Click **Reset** to reset the default settings.

Provision Optical Safety

Use this task to provision the optical safety parameters for cards.

Before you begin

- [Log into the SVO Web Interface](#)
- [Open the Card View](#)

Procedure

Step 1 Click the **Maintenance > Optical Safety** tabs.

Step 2 Modify required settings described in the following table:

Table 4: Optical Safety Parameters for Cards

Parameter	Description	Options
Interface	(Display only) Displays the port name, port type, and direction.	—

Parameter	Description	Options
Supported Safety	(Display only) Displays the supported safety mechanism.	<ul style="list-style-type: none"> • ALS for line cards and control cards. • ALS-OSRI for amplifier cards.
ALS Mode	Automatic laser shutdown mode. The ALS mode is disabled for RX ALS interfaces.	<p>From the drop-down list, choose one of the following:</p> <ul style="list-style-type: none"> • ALS-Disabled—Deactivates ALS. • Automatic Restart—(Default) ALS is active. The power is automatically shut down when needed, and it automatically tries to restart using a probe pulse until the cause of the failure is repaired. • Manual Restart
OSRI	<p>Optical safety remote interlock. The default value is OSRI-OFF. When set to OSRI-ON, the TX output power is shut down.</p> <p>Note OSRI configuration is not supported on the transponder and muxponder cards.</p>	<p>From the drop-down list, choose one of the following:</p> <ul style="list-style-type: none"> • OSRI-OFF • OSRI-ON
ALS Status	(Display only) ALS status of the device.	<ul style="list-style-type: none"> • Working • Shutdown
Recovery Pulse Interval	Displays the interval between two optical power pulses.	60 to 300 seconds.
Recovery Pulse Duration	Displays the duration of the optical power pulse that begins when an amplifier restarts.	2 to 100 seconds
Manual Restart	Triggers manual restart action for the ALS interface. However, manual restart does not happen if Mode is set to Automatic Restart or Disabled.	—

Step 3 Click **Apply** to save the changes.

View Insertion Loss Parameters

Use this task to view the insertion loss parameters of cards.

Before you begin

- [Log into the SVO Web Interface](#)
- [Open the Card View](#)

Procedure

Click the **Maintenance > Insertion Loss** tabs to view the insertion loss parameters.

The Insertion Loss tab displays the following information:

- **Insertion Loss Path**—Displays the insertion loss path.
- **IL Value (dB)**—Displays the insertion loss value.

Note When the card is removed, the last retrieved Insertion Loss values are displayed in the SVO web UI. When the card is replaced, the Insertion Loss values are updated in the SVO web UI.

Manage the Protection Group

Use this task to view the protection group that is automatically created when a new PSM card is provisioned. You can also perform a switch operation on the interfaces.

Before you begin

- [Log into the SVO Web Interface](#)
- [Open the Card View](#)

Procedure

Step 1 Click the **Maintenance > Protection** tabs to view the parameters of the PSM protection group.

The Protection tab displays the following information:

- **Name**—Name of the protection group
- **Protection Type**—The protection type is splitter

- **Active Interfaces**—The interfaces on which the traffic is present
- **Working Interfaces**—The working interfaces are the active interfaces when the protection group is created.
- **Protection Interfaces**—The protection interfaces when the protection group is created.
- **Switch Type**—The switch type is bidirectional-switching.
- **Revertive**—If set to true, the traffic reverts to the working port after failure conditions remain corrected for the amount of time entered in the Reversion Time field.
- **Reversion Time (min)**—Reversion time is the amount of time that will elapse before the traffic reverts to the working card. The reversion timer starts after conditions causing the switch are cleared. The range is from one to 12 minutes.
- **Reversion Pulse Width (sec)**—Reversion Pulse Width is between 10 to 200 seconds and is configurable only if the protection is revertive. By default, the duration is set to 60 seconds.

Note The following fields in the protection group are editable in the Chassis view > Provisioning tab:

- Name
- Revertive
- Reversion Time
- Reversion Pulse Width

Step 2 Click + to view the protection group data.

The interfaces of the protection group are displayed.

- **Interface**—displays the name of the interface
- **Entity**—Displays the entity of the interface, whether it is working or protect
- **Entity Status**—Displays the status of the entity, whether it is active or Standby
- **Switch Status**—Displays the switch status when a switch operation is performed.

Step 3 To perform a switch operation between the interfaces of a protection group, perform these steps:

Note A switch operation can only be performed if revertive is set to false.

- a. Check the check box corresponding to the interface you want to perform a switch operation.
 - b. Click **Edit**.
The Switch Command dialog box appears.
 - c. Select an option from the **Action** drop-down list.
The options available are—Lock-Out, Force-Switch, Manual-Switch, and Release.
 - d. Click **Apply**.
-