



Configuring Controllers

There are three types of controllers for the line card. The controllers are the optics controller, the ethernet controller, and the coherent DSP controller. This chapter describes the procedures used to configure these controllers.

- [AINS, on page 1](#)
- [FEC, on page 8](#)
- [Laser Squelching, on page 12](#)
- [Idle Insertion, on page 16](#)
- [FlexO GID and IID, on page 22](#)
- [Link Layer Discovery Protocol \(LLDP\) Support on Management Interface, on page 23](#)
- [MAC Address Snooping on Client Ports, on page 27](#)
- [Transmit Shutdown, on page 29](#)
- [Loopback, on page 31](#)
- [Restore Factory Settings, on page 38](#)
- [Headless Mode, on page 39](#)
- [Trail Trace Identifier, on page 40](#)
- [Chromatic Dispersion, on page 43](#)
- [Transmit Power, on page 46](#)
- [Laser Bias Current High Threshold, on page 47](#)
- [Differential Group Delay Threshold, on page 49](#)
- [Optical Signal to Noise Ratio, on page 51](#)
- [Receive Power Threshold, on page 53](#)
- [Transmit Power Threshold, on page 55](#)
- [Frequency, on page 57](#)
- [CCMD-16 Controllers, on page 58](#)
- [Configure Controller Parameters for NCS1K14-CCMD-16-C and NCS1K14-CCMD-16-L Cards, on page 61](#)

AINS

The Automatic-In-Service (AINS) feature allows the controller to automatically move to the automatic-in-service state after the maintenance window is completed. A soak time period is associated with the AINS state. The controller automatically moves to the In-Service state after the soak time period is

completed. During the AINS maintenance window, alarms are not propagated to the EMS/NMS monitoring system.

You can configure AINS on the client ports of the QXP, 1.2T, 2.4T, and 2.4TX cards.

AINS States

The following table lists the AINS states.

State	Description
None	AINS is not enabled on the controller or the soak time period is complete.
Pending	AINS is configured on the controller. However, the soak time period has not started because either the primary state of controller is in Shutdown, Admin down, or Not ready state or the secondary state is in Maintenance state. AINS can also move to Pending state if alarms are raised during the soak time period.
Running	AINS is enabled on the controller. The primary state of the controller is Up and the secondary state is AINS.

If there are any service-affecting alarms when AINS is running on ethernet or optics controllers, the AINS state moves to Pending state. When the alarms are cleared, the AINS state moves to Running state.

The AINS soak time period restarts when there are line card reloads, XR reloads, line card warm reloads, power cycles, or alarm conditioning.

Soak Time Period

You can configure the soak time period to be between 1 minute to 48 hours.

All alarms are suppressed during the AINS state. When the optical and ethernet alarms are raised on the port during the soak time period, the AINS state moves to Pending. These alarms are not displayed in the output of the **show alarms brief card location 0/RP0/CPU0 active** command but in the output of the **show alarms brief card location 0/RP0/CPU0 conditions** command. When all the alarms clear, the soak time period starts, and the AINS state moves to Running. When the soak time period expires, the port moves to IS state.

Configuring AINS

To configure AINS on a controller, use the following command:

automatic-in-service controller *controller rate controller* **hours** *hours* **minutes** *minutes*

The following is a sample to configure AINS on a controller.

```
RP/0/RP0/CPU0:ios#configure
RP/0/RP0/CPU0:ios#automatic-in-service controller coherentDSP 0/0/0/12 hours 0 minutes 15
RP/0/RP0/CPU0:ios(config)#commit
```

To configure AINS on a muxponder slice, use the following command:

configure

hw-module location *location mxponder-slice slice-number client-port-ains-soak hours hours minutes minutes*

commit

The following is a sample in which slice 0 client ports are configured with AINS with soak time period specified to be 40 minutes.

```
RP/0/RP0/CPU0:ios#configure
RP/0/RP0/CPU0:ios(config)#hw-module location 0/3/nxr0 mxponder-slice 0 client-port-ains-soak
  hours 0 minutes 40
RP/0/RP0/CPU0:ios(config)#commit
```

To configure AINS globally, use the following command:

ains-soak hours hours minutes minutes

The following is a sample to configure AINS globally.

```
RP/0/RP0/CPU0:ios#configure
RP/0/RP0/CPU0:ios(config)#ains-soak hours 0 minutes 15
RP/0/RP0/CPU0:ios(config)#commit
```

Disabling AINS

To disable AINS on all muxponder client ports, set the hours and minutes to 0. Use the following commands:

configure

hw-module location *location mxponder-slice slice-number client-port-ains-soak hours hours minutes minutes*

commit

The following is a sample in which AINS is disabled on all client ports.

```
RP/0/RP0/CPU0:ios#configure
RP/0/RP0/CPU0:ios(config)#hw-module location 0/3/nxr0 mxponder-slice 0 client-port-ains-soak
  hours 0 minutes 0
RP/0/RP0/CPU0:ios(config)#commit
```

To disable AINS on a muxponder slice, set the hours and minutes to 0. Use the following command:

configure

hw-module location *location mxponder-slice slice-number client-port-ains-soak hours hours minutes minutes*

commit

The following is a sample in which AINS is disabled on all client ports of slice 0.

```
RP/0/RP0/CPU0:ios#configure
RP/0/RP0/CPU0:ios(config)#hw-module location 0/3/nxr0 mxponder-slice 0 client-port-ains-soak
  hours 0 minutes 0
RP/0/RP0/CPU0:ios(config)#commit
```

Displaying the AINS Configuration

The AINS Soak field in the output indicates the current state of AINS. The current state can be None, Pending, or Running. The Total Duration field indicates the total soak time period that is configured. The Remaining Duration field indicates the soak time that remains, after which, the AINS state moves to None.

This example displays the ethernet controller statistics with AINS Soak in running state.

```
RP/0/RP0/CPU0:ios#show controller HundredGigECtrlr 0/1/0/2
```

```
Thu Feb 21 19:52:55.001 UTC
```

```
Operational data for interface HundredGigECtrlr0/1/0/2:
```

```
State:
```

```
Administrative state: enabled
```

```
Operational state: Up
```

```
LED state: Green On
```

```
Maintenance: Disabled
```

```
AINS Soak: Running
```

```
  Total Duration: 0 hour(s) 15 minute(s)
```

```
  Remaining Duration: 0 hour(s) 5 minute(s) 37 second(s)
```

```
Laser Squelch: Disabled
```

```
Phy:
```

```
Media type: Not known
```

```
Autonegotiation disabled.
```

```
Operational values:
```

```
Speed: 100Gbps
```

```
Duplex: Full Duplex
```

```
Flowcontrol: None
```

```
Loopback: None (or external)
```

```
BER monitoring:
```

```
  Not supported
```

```
Holdoff Time: 0ms
```

This example displays the ethernet controller statistics with AINS Soak in pending state.

```
RP/0/RP0/CPU0:ios#show controllers HuC 0/0/0/2
```

```
Thu Mar 12 13:52:12.129 UTC
```

```
Operational data for interface HundredGigECtrlr0/0/0/2:
```

```
State:
```

```
Administrative state: enabled
```

```
Operational state: Down (Reason: State undefined)
```

```
LED state: Red On
```

```
Maintenance: Disabled
```

```
AINS Soak: Pending
```

```
  Total Duration: 0 hour(s) 30 minute(s)
```

```
  Remaining Duration: 0 hour(s) 30 minute(s) 0 second(s)
```

```
Laser Squelch: Disabled
```

```
Phy:
```

```
Media type: Not known
```

```
Alarms:
```

```
  Current:
```

```
    Local Fault
```

```
Statistics:
```

```
  FEC:
```

```
    Corrected Codeword Count: 0
```

```
    Uncorrected Codeword Count: 9
```

```
Autonegotiation disabled.
```

```
Operational values:
  Speed: 100Gbps
  Duplex: Full Duplex
  Flowcontrol: None
  Loopback: None (or external)
  BER monitoring:
    Not supported
  Forward error correction: Standard (Reed-Solomon)
  Holdoff Time: 0ms
```

This example displays the optics controller statistics with AINS Soak in running state.

```
RP/0/RP0/CPU0:ios#show controller optics 0/1/0/3
```

```
Thu Feb 21 19:45:41.088 UTC
```

```
Controller State: Up
```

```
Transport Admin State: Automatic In Service
```

```
Laser State: On
```

```
LED State: Green
```

```
Optics Status
```

```
Optics Type: 400G QSFP-DD DR4
```

```
Alarm Status:
```

```
-----
Detected Alarms: None
```

```
LOS/LOL/Fault Status:
```

```
Alarm Statistics:
```

```
-----
HIGH-RX-PWR = 0          LOW-RX-PWR = 0
HIGH-TX-PWR = 0          LOW-TX-PWR = 0
HIGH-LBC = 0             HIGH-DGD = 0
OOR-CD = 0               OSNR = 0
WVL-OOL = 0              MEA = 0
IMPROPER-REM = 0
TX-POWER-PROV-MISMATCH = 0
```

```
Performance Monitoring: Enable
```

```
THRESHOLD VALUES
```

```
-----
```

Parameter	High Alarm	Low Alarm	High Warning	Low Warning
Rx Power Threshold(dBm)	4.9	-12.0	0.0	0.0
Tx Power Threshold(dBm)	3.5	-10.1	0.0	0.0
LBC Threshold(mA)	N/A	N/A	0.00	0.00

```
LBC High Threshold = 98 %
Polarization parameters not supported by optics
```

```
Total TX Power = 6.39 dBm
```

```
Total RX Power = 5.85 dBm
```

Lane	Laser Bias	TX Power	RX Power	Output Frequency
1	75.0 %	0.59 dBm	0.63 dBm	230.43 THz
2	68.6 %	0.06 dBm	-0.68 dBm	230.43 THz
3	69.0 %	0.26 dBm	-0.63 dBm	230.43 THz
4	69.1 %	0.56 dBm	-0.10 dBm	230.43 THz

Transceiver Vendor Details

```

Form Factor   : QSFP-DD
Name          : INNOLIGHT
Part Number   : T-DP4CNT-NGL
Rev Number    : 1A
Serial Number  : INLBFI940027
PID           : T-DP4CNT-NGL
VID           : 1A
Date Code(yy/mm/dd) : 21/08/21
Fiber Connector Type: MPO
Otn Application Code: Not Set
Sonet Application Code: Not Set
Ethernet Compliance Code: 400GBASE-DR4

```

Transceiver Temperature : 32 Celsius

```

AINS Soak           : Running
AINS Timer        : 0h, 15m
AINS remaining time : 771 seconds

```

When the soak time expires, AINS state changes from Running to None. The Transport Admin State of optics controller changes from Automatic In Service to In Service.

```
RP/0/RP0/CPU0:ios# show controllers optics 0/1/0/3
```

Thu Feb 21 20:02:34.126 UTC

Controller State: Up

Transport Admin State: In Service

Laser State: On

LED State: Green

Optics Status

Optics Type: Grey optics

Alarm Status:

Detected Alarms: None

LOS/LOL/Fault Status:

Alarm Statistics:

```

-----
HIGH-RX-PWR = 0          LOW-RX-PWR = 0
HIGH-TX-PWR = 0          LOW-TX-PWR = 0
HIGH-LBC = 0             HIGH-DGD = 0
OOR-CD = 0               OSNR = 0
WVL-OOL = 0              MEA = 0

```

```
IMPROPER-REM = 0
TX-POWER-PROV-MISMATCH = 0
```

Performance Monitoring: Enable

THRESHOLD VALUES

Parameter	High Alarm	Low Alarm	High Warning	Low Warning
Rx Power Threshold(dBm)	4.9	-12.0	0.0	0.0
Tx Power Threshold(dBm)	3.5	-10.1	0.0	0.0
LBC Threshold(mA)	N/A	N/A	0.00	0.00

LBC High Threshold = 98 %
Polarization parameters not supported by optics

Total TX Power = 6.41 dBm

Total RX Power = 5.85 dBm

Lane	Laser Bias	TX Power	RX Power	Output Frequency
1	74.9 %	0.60 dBm	0.63 dBm	230.43 THz
2	68.6 %	0.06 dBm	-0.70 dBm	230.43 THz
3	69.0 %	0.30 dBm	-0.63 dBm	230.43 THz
4	69.1 %	0.57 dBm	-0.11 dBm	230.43 THz

Transceiver Vendor Details

```
Form Factor      : QSFP28
Name             : CISCO-FINISAR
Part Number      : FTLC1152RGPL-C2
Rev Number       : CISCO-FINISAR
Serial Number    : FNS22150LEC
PID              : QSFP-100G-CWDM4-S
VID              : V02
CISCO-FINISAR
Date Code(yy/mm/dd) : 18/04/11
Fiber Connector Type: LC
Sonet Application Code: Not Set
Ethernet Compliance Code: 100GBASE-CWDM4
```

Transceiver Temperature : 32 Celsius

```
AINS Soak           : None
AINS Timer         : 0h, 0m
AINS remaining time : 0 seconds
```

This example displays the coherentDSP controller statistics with AINS Soak in running state for a 2.4TX card.

```
RP/0/RP0/CPU0:ios#show controllers coherentDSP 0/0/0/7
Port                               : CoherentDSP 0/0/0/7
Controller State                    : Up
Inherited Secondary State          : Automatic-In-Service
Configured Secondary State         : Normal
Derived State                      : Automatic-In-Service
Loopback mode                      : None
BER Thresholds                     : SF = 1.0E-5  SD = 1.0E-7
Performance Monitoring              : Enable
Bandwidth                          : 800.0Gb/s
```

```

Alarm Information:
LOS = 0 LOF = 0 LOM = 0
OOF = 0 OOM = 0 AIS = 0
IAE = 0 BIAE = 0          SF_BER = 0
SD_BER = 0          BDI = 0 TIM = 1
FECMISMATCH = 0 FEC-UNC = 0          FLEXO_GIDM = 1
FLEXO-MM = 0          FLEXO-LOM = 0          FLEXO-RDI = 1
FLEXO-LOF = 1
Detected Alarms                               : None

Bit Error Rate Information
PREFEC BER                                     : 2.95E-04
POSTFEC BER                                    : 0.00E+00
Q-Factor                                       : 10.70 dB

Q-Margin                                       : 4.40 dB

Instantaneous Q-Margin                        : 4.40 dB

TTI :
    Remote hostname                           : chassisA164
    Remote interface                          : CoherentDSP 0/1/0/7
    Remote IP addr                            : 0.0.0.0

FEC mode                                       : Soft-Decision 15

Flexo-Mode                                     : Enable
Flexo Details:
    Tx GID                                     : 1
    TX IID                                     : 1, 2, 3, 4, 5, 6, 7, 8,
    Rx GID                                     : 1
    RX IID                                     : 1, 2, 3, 4, 5, 6, 7, 8,

AINS Soak                                     : Running
AINS Timer                                    : 0h, 20m
AINS remaining time                          : 1196 seconds

```

FEC

Forward Error Correction (FEC) is used for controlling errors during data transmission. This feature can be enabled on 1.2T and 2.4T cards and works by adding data redundancy to the transmitted message using an algorithm. This redundancy allows the receiver to detect and correct a limited number of errors occurring anywhere in the message, instead of having to ask the transmitter to resend the message.

FEC is automatically enabled on the pluggables installed in the Cisco NCS 1014. When you upgrade the software of an NCS 1014 with pluggables in the FEC disabled mode, traffic is affected.

The following sample shows the running FEC configuration on a 2.4T card:

```

RP/0/RP0/CPU0:ios#sh controllers fourHundredGigEctrlr 0/1/0/1
Fri Nov 17 10:01:22.840 UTC
Operational data for interface FourHundredGigEctrlr0/1/0/1:

State:
Administrative state: enabled
Operational state: Up
LED state: Green On
Maintenance: Enabled
AINS Soak: None

```



```

Total Duration: 0 hour(s) 0 minute(s)
Remaining Duration: 0 hour(s) 0 minute(s) 0 second(s)
Laser Squelch: Disabled
Insert Idle Ingress: Disabled
Insert Idle Egress: Disabled

```

Phy:

Media type: Not known

Statistics:

FEC:

Corrected Codeword Count: 72671614	Valid: True	Start time:
15:53:12 Thu Nov 16 2023		
Uncorrected Codeword Count: 12	Valid: True	Start time:
15:53:12 Thu Nov 16 2023		
PCS:		
Total BIP errors: 0	Valid: True	Start time:
15:53:12 Thu Nov 16 2023		
Total frame errors: 0	Valid: False	Start time:
15:53:12 Thu Nov 16 2023		
Total Bad SH: 0	Valid: False	Start time:
15:53:12 Thu Nov 16 2023		

Autonegotiation disabled.

Operational values:

```

Speed: 400Gbps
Duplex: Full Duplex
Flowcontrol: None
Loopback: Line
BER monitoring:
    Not supported
Forward error correction: Standard (Reed-Solomon)
Holdoff Time: 0ms

```

Configuring FEC on the Ethernet Controller

To configure FEC on the Ethernet controller, use the following command:

configure

```
controller { HundredGigEctr1r | fourHundredGigEctr1r } R/S/I/P fec { none | standard }
```

commit

The following samples show how to configure FEC on the Ethernet controller:

```

RP/0/RP0/CPU0:ios#configure
RP/0/RP0/CPU0:ios(config)#controller HundredGigEctr1r 0/1/0/6/ fec standard
RP/0/RP0/CPU0:ios(config)#commit

```

The following sample shows the running FEC configuration on the Ethernet controller:

```

RP/0/RP0/CPU0:BH-SIT2#show controller HundredGigEctr1r 0/1/0/6
Tue Jul 16 15:30:30.165 IST
Operational data for interface HundredGigEctr1r0/1/0/6/2:

```

State:

```

Administrative state: enabled
Operational state: Down (Reason: State undefined)
LED state: Red On
Maintenance: Disabled
AINS Soak: None

```

```
Total Duration: 0 hour(s) 0 minute(s)
Remaining Duration: 0 hour(s) 0 minute(s) 0 second(s)
Laser Squelch: Disabled
```

```
Phy:
Media type: Not known
Alarms:
  Current:
    Loss of Frequency Sync Data
Statistics:
  FEC:
    Corrected Codeword Count: 0
    Uncorrected Codeword Count: 0
```

Autonegotiation disabled.

```
Operational values:
Speed: 100Gbps
Duplex: Full Duplex
Flowcontrol: None
Loopback: None (or external)
BER monitoring:
  Not supported
Forward error correction: Standard (Reed-Solomon)
Holdoff Time: 0ms
```

From Release 24.2.11, the **show controllers** command output displays post FEC BER and pre FEC BER for the Ethernet controllers of the 2.4T and 2.4TX cards.

```
RP/0/RP0/CPU0:ios#show controllers fourHundredGigEctrlr 0/1/0/2
Thu Jan 18 18:58:03.846 UTC
Operational data for interface FourHundredGigEctrlr0/1/0/2:
```

```
State:
Administrative state: enabled
Operational state: Up
LED state: Green On
Maintenance: Disabled
AINS Soak: None
  Total Duration: 0 hour(s) 0 minute(s)
  Remaining Duration: 0 hour(s) 0 minute(s) 0 second(s)
Laser Squelch: Disabled
Insert Idle Ingress: Disabled
Insert Idle Egress: Disabled
```

```
Phy:
Media type: Not known
Statistics:
  FEC:
    Corrected Codeword Count: 358543          Valid: True      Start time:
18:54:03 Thu Jan 18 2024
    Uncorrected Codeword Count: 0           Valid: True      Start time:
18:54:03 Thu Jan 18 2024
  PCS:
    Total BIP errors: 0                     Valid: True      Start time:
18:54:03 Thu Jan 18 2024
    Total frame errors: 0                   Valid: False     Start time:
18:54:03 Thu Jan 18 2024
    Total Bad SH: 0                         Valid: False     Start time:
18:54:03 Thu Jan 18 2024
```

Autonegotiation disabled.

Operational values:

```

Speed: 400Gbps
Duplex: Full Duplex
Flowcontrol: None
Loopback: None (or external)
Pre FEC BER: 9.1E-10
Post FEC BER: 0.0E+00
BER monitoring:
    Not supported
Forward error correction: Standard (Reed-Solomon)
Holdoff Time: 0ms
    
```

FEC States for CoherentDSP Controller

The following table lists the FEC states for the coherentDSP controllers.

Table 1: FEC State for CoherentDSP Controllers

State	Description
EnhancedSD15	FEC Soft-Decision 15. (Default)

Q-Margin Support

Q-margin is an important optical parameter that characterizes the health of an optical link. The Q-margin value is calculated based on the average bit error rate (BER) in the optical link.

Enhanced Q-Margin Support

Enhanced Q-Margin is supported for Forward Error Correction (FEC) and Performance Monitoring on CoherentDSP controllers for 2.4T cards. Enhanced Q-margin provides a better error free signal in the optical link. The enhanced Q-margin value is calculated based on the maximum number of errors per frame. An attribute that is called instantaneous Q-margin is displayed in the output of the **show controllers coherentDSP** command. The lower the delta value between the instantaneous Q-margin value with the Q-margin value, the better the FEC performance of the NCS 1014 system. The instantaneous Q-margin values thus help you to optimize the system with continuous error correction in subsea transport networks.

Configuring FEC on CoherentDSP Controllers

To configure FEC on the CoherentDSP controller, use the following command:

```

configure
controller coherentDSP R/S/I/P
fec {EnhancedSD15}
commit
    
```

The following sample shows how to configure FEC on the CoherentDSP controller:

```

RP/0/RP0/CPU0:ios#configure
RP/0/RP0/CPU0:ios(config)#controller coherentDSP 0/0/0/0
RP/0/RP0/CPU0:ios(config-CoDSP)#fec EnhancedSD15
Tue Feb 25 11:25:52.670 UTC
WARNING! Changing FEC mode can impact traffic
RP/0/RP0/CPU0:ios(config-CoDSP)#commit
    
```

Verifying FEC on CoherentDSP Controllers

The following sample shows the FEC configuration on the CoherentDSP controller:

```
RP/0/RP0/CPU0:ios#show controllers coherentDSP 0/0/0/0

Tue Feb 25 11:26:08.235 UTC

Port                               : CoherentDSP 0/0/0/0
Controller State                    : Up
Inherited Secondary State          : Normal
Configured Secondary State         : Normal
Derived State                       : In Service
Loopback mode                       : None
BER Thresholds                     : SF = 1.0E-5  SD = 1.0E-7
Performance Monitoring              : Enable
Bandwidth                           : 50.0Gb/s
Alarm Information:
LOS = 1 LOF = 0 LOM = 0
OOF = 0 OOM = 0 AIS = 0
IAE = 0 BIAE = 0          SF_BER = 0
SD_BER = 0          BDI = 0 TIM = 0
FECMISMATCH = 0 FEC-UNC = 0
Detected Alarms                    : None
Bit Error Rate Information
PREFEC BER                         : 0.00E+00
POSTFEC BER                        : 0.00E+00
Q-Factor                           : 0.00 dB
Q-Margin                            : -5.00dB
Instantaneous Q_margin              : 0 dB

TTI :
Remote IP addr                      : 0.0.0.0
FEC mode                          : Soft-Decision 15

AINS Soak                           : None
AINS Timer                           : 0h, 0m
AINS remaining time                  : 0 seconds
```

Laser Squelching

You can enable laser squelching on Ethernet controllers. Laser squelching can be enabled on QXP, 1.2T, 2.4T, and 2.4TX cards which shuts down the laser in the event of trunk faults (LOS, LOF), and a SQUELCHED alarm is raised on the mapped client port.

Laser squelching uses an interrupt based method. Hence squelching happens faster when compared to previous releases. Squelch happens for client alarms also like Ingress LF, LOA, and CSF (not for egress client alarms) in addition to trunk fault cases.

To configure laser squelching on 1.2T card, use the following commands:

configure

controller HundredGigECtrlr *Rack/Slot/Instance/Port*

laser-squelch

commit

To configure laser squelching on a 2.4T and 2.4TX cards, use the following commands:

configure

controller HundredGigECtrlr *Rack/Slot/Instance/Port/Lane* | **controller fourHundredGigECtrlr**
Rack/Slot/Instance/Port

laser-squelch**commit**

Note In case of muxponder configuration on the 2.4TX card, and if laser squelch is configured on the split port, whenever a fault is received on any one trunk, the corresponding split port will be squelched.

The following is a sample where laser squelching is enabled on the Ethernet controller of a 2.4T card and a 2.4TX card.

```
RP/0/RP0/CPU0:ios#configure
RP/0/RP0/CPU0:ios(config)#controller fourHundredGigECtrlr 0/1/0/1
RP/0/RP0/CPU0:ios(config-eth-ctrlr)#laser-squelch
RP/0/RP0/CPU0:ios(config-eth-ctrlr)#commit
```

The following is a sample to view the laser squelch status on the controller of a 2.4T card and a 2.4TX card.

```
RP/0/RP0/CPU0:ios#show controllers fourHundredGigECtrlr 0/0/0/4
Fri Nov 17 14:26:43.213 UTC
Operational data for interface FourHundredGigECtrlr0/0/0/4:
```

State:

```
Administrative state: enabled
Operational state: Up
LED state: Green On
Maintenance: Disabled
AINS Soak: Running
  Total Duration: 0 hour(s) 5 minute(s)
  Remaining Duration: 0 hour(s) 3 minute(s) 34 second(s)
Laser Squelch: Enabled
Insert Idle Ingress: Disabled
Insert Idle Egress: Disabled
```

Phy:

```
Media type: Not known
```

Statistics:

```
FEC:
  Corrected Codeword Count: 580070472          Valid: False      Start time:
13:12:29 Fri Nov 17 2023
  Uncorrected Codeword Count: 0                Valid: False      Start time:
13:12:29 Fri Nov 17 2023
PCS:
  Total BIP errors: 0                          Valid: False      Start time:
13:12:29 Fri Nov 17 2023
  Total frame errors: 0                       Valid: False      Start time:
13:12:29 Fri Nov 17 2023
  Total Bad SH: 0                             Valid: False      Start time:
13:12:29 Fri Nov 17 2023
```

```
Autonegotiation disabled.
```

```
Operational values:
Speed: 400Gbps
Duplex: Full Duplex
Flowcontrol: None
Loopback: None (or external)
BER monitoring:
    Not supported
Forward error correction: Standard (Reed-Solomon)
Holdoff Time: 0ms
```

Protection Switching Use Cases

Fast-Squelching provides increased protection switching speed when there is a trunk fault or a client fault. Fast-Squelching is supported on 1.2T cards.



Note Protection Switching is not supported on 2.4T card.

The following sample topology includes a Far End (FE) station and a Near End (NE) station. Each station includes an NCS 1014 node having two line cards. The nodes are connected to the respective Traffic generators through a Protection Switching Module (PSM).

Figure 1: Reference Topology for Protection Switching

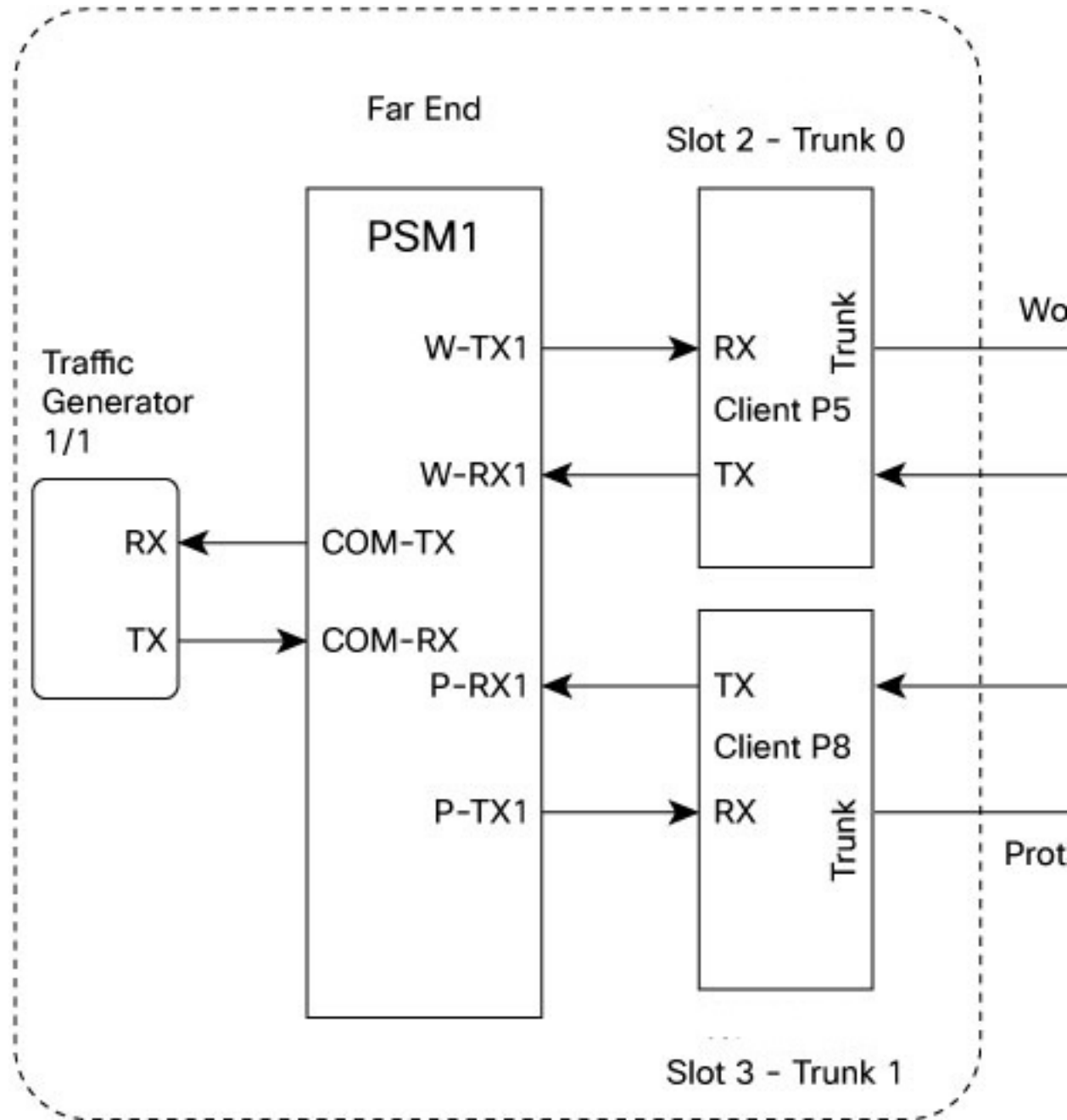

Protection Switching Principle (Trunk fault)

If there is a fiber cut in the trunk working path from the FE station to the NE station, an LOS alarm is raised on the NE working trunk. This results in the squelching of all client ports mapped to the working NE trunk port. As the laser of the client port is squelched, LOS is reported on the W-RX2 port of the PSM2. As the received optical power on the W-RX2 port of PSM is below the threshold, PSM2 switches to receive the optical signal in the P-RX2 port instead of the W-RX2 port. Hence switching happens for traffic from work to protect in FE station to NE station direction.

In the case of a unidirectional trunk fault, switching happens in one direction as explained above. In the other direction, when LOS is received at the W-RX2 port of PSM2, W-TX2 sends LOS for 25 milliseconds. When LOS is reported on the NE client port, fault gets propagated over the trunk, resulting in the squelching of FE station client ports. Finally, the LOS on the PSM port results in switching in this direction as well. In this way, bidirectional switching is implemented.

Protection Switching Principle (Client fault)

When a client failure happens on the FE station, a Client Signal Failure (CSF) alarm is raised on the NE station trunk. The CSF on the trunk results in the squelching of the corresponding client port, and the PSM switching happens. In summary, a fault on the NE station client RX port results in CSF on the FE station trunk, and the switching happens. And, a fault on the NE station client TX port results in LOS on the PSM ports, and the switching happens.



Note

- PSM must be in the standalone mode.
- PSM alarm threshold must be set to +/- 3 dBm from the actual power received in the PSM RX port.
- If line card protection is required, the working and protect path must be configured in two different line cards.
- If only client protection is required, the working and protection path can be configured in the same line card.
- If the LC trunk configuration is x50 rate, then we can't use single line card for work and protection due to x50 coupled mode limitations (coupled trunk).
- Manual switch, Force switch, and lock-out protection on PSM, result in bidirectional switching.

Idle Insertion

When a fault occurs on the trunk port, you can hold the propagation of local faults using the idle insertion feature. This feature is can be enabled on the ethernet controllers of 1.2T, 2.4T, and 2.4TX cards by configuring the hold-off timer.

When the fault occurs on the trunk, idles are inserted in the traffic stream from the trunk port to the client port for the duration of the configured holdoff-time. If the trunk port remains faulty beyond the configured holdoff-time, a local fault is transmitted towards the client device. If the trunk recovers from the fault before the holdoff-time expires, traffic resumes.

This feature can be used on customer deployments to prevent reset of client ports during a PSM switchover.

Configure Idle Insertion

You can enable the idle insertion feature on a 1.2T card using the following commands:

```
configure
```

```
controller HundredGigECtrlr Rack/Slot/Instance/Port
```

```
holdoff-time trunk-fault time-value
```

You can enable the idle insertion feature on 2.4T card and 2.4TX card using the following commands:

configure

controller HundredGigECtrlr *Rack/Slot/Instance/Port/Lane* | **controller fourHundredGigECtrlr** *Rack/Slot/Instance/Port*

holdoff-time trunk-fault *time-value*

The range of *timevalue* is from 0 ms to 3000 ms.



Note In case of muxponder configuration on the 2.4TX card, holdoff timer is not supported on the split ports.

Example 1

The following is a sample for enabling the hold off -timer in 100GE controller:

```
RP/0/RP0/CPU0:ios#configure
RP/0/RP0/CPU0:ios(config)#controller HundredGigECtrlr 0/0/0/4/1
RP/0/RP0/CPU0:ios (config-eth-ctrlr)#holdoff-time trunk-fault 3000
RP/0/RP0/CPU0:ios (config-eth-ctrlr)#commit
```

View Hold Off Timer

To view the hold-off time that is configured on 100GE controller, use the following command:

show controllers hundredGigECtrlr *Rack/Slot/Instance/Port*

Example 2

```
RP/0/RP0/CPU0:ios#show controllers HundredGigECtrlr 0/1/0/1
Fri Feb 22 18:58:06.888 UTC
Operational data for interface HundredGigECtrlr0/1/0/1:
```

State:

```
Administrative state: enabled
Operational state: Up
LED state: Green On
Maintenance: Disabled
AINS Soak: None
  Total Duration: 0 hour(s) 0 minute(s)
  Remaining Duration: 0 hour(s) 0 minute(s) 0 second(s)
Laser Squelch: Disabled
```

Phy:

```
Media type: Not known
Statistics:
  FEC:
    Corrected Codeword Count: 0
    Uncorrected Codeword Count: 0
```

Autonegotiation disabled.

Operational values:

```
Speed: 100Gbps
Duplex: Full Duplex
Flowcontrol: None
Loopback: None (or external)
BER monitoring:
```

```

Not supported
Forward error correction: Standard (Reed-Solomon)
Holdoff Time: 3000ms

```

Idle Insertion for Ethernet Controllers

Idle insertion for Ethernet controllers feature allows you to perform end-to-end link verification between 100GE or 400GE Ethernet controllers before bringing up the actual traffic. This feature enables you to perform pre-provisioning checks to isolate link errors in advance without any Ethernet testers.



Note OTU4 client rate is not supported.

Idle frames can be inserted in both the ingress and egress directions on Ethernet controllers and the LOCAL-FAULT and REMOTE-FAULT alarms are cleared. The performance monitoring counters on the pcs layer are monitored to check for any errors on the link.



Warning Do not configure the Idle insertion for Ethernet controllers feature on the link that carries live traffic.

Recommended Topology for Link Verification

The following diagram describes the recommended topology for link verification:

Figure 2: Topology for Link Verification

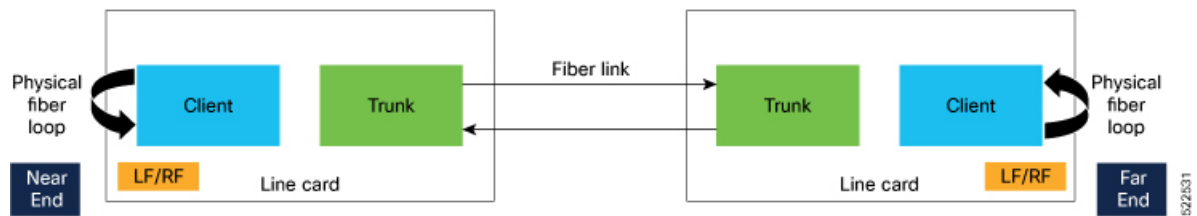

The following steps describe the sequence for link verification using this topology:

1. Both the near-end and far-end clients have the LOCAL-FAULT alarm if the trunk is up on both the ends.
2. Enable idle ingress on the near-end client. The idle frame transmits toward the trunk link and reaches the far-end client. The LOCAL-FAULT alarm is then cleared on the far-end client.
3. As the far-end client has fiber loop, the idle frame is inserted again into the same client RX toward the trunk link and reaches the near-end client. The LOCAL-FAULT alarm is then cleared on the near-end client as well.
4. When you enable idle insertion on any client and in any direction, the idle frame transmits in loop similar to this topology and all the LOCAL-FAULT and the REMOTE-FAULT alarms are cleared.
5. The link can be monitored after all the alarms are cleared. The link has a problem if any alarm is reported during the link test.

Configuring Idle Insertion for Ethernet Controllers

Before You Begin:

- Do not configure idle frame insertion with hold-off timer.

You can configure this feature by using the following commands:

```
configure  
controller hundredGigECtrlr Rack/Slot/Instance/Port/  
insert-idle ingress  
insert-idle egress  
commit  
end
```

The following is a sample for enabling the idle ingress and idle egress in 100GE controllers:

```
RP/0/RP0/CPU0:ios#configure  
RP/0/RP0/CPU0:ios(config)#controller hundredGigECtrlr 0/2/0/2  
RP/0/RP0/CPU0:ios(config-eth-ctrlr)#insert-idle ingress  
RP/0/RP0/CPU0:ios(config-eth-ctrlr)#insert-idle egress  
RP/0/RP0/CPU0:ios(config-eth-ctrlr)#commit  
RP/0/RP0/CPU0:ios(config-eth-ctrlr)#end
```

You can disable this feature by using the following commands:

```
configure  
controller hundredGigECtrlr Rack/Slot/Instance/Port  
no insert-idle ingress  
no insert-idle egress  
commit  
end
```

Limitation

After disabling the idle frame insertion feature, the LOCAL-FAULT or REMOTE-FAULT alarm may not appear again because the idle frames are in loop. Hence, you must break the idle frame loop in the link by performing either one of the following:

- Perform fiber OIR on either the near-end or far-end client port.
- Perform shut and unshut operation on any client port.

Verifying Idle Insertion Configuration for Ethernet Controllers

To verify the *idle ingress* and *idle egress* that is configured on the Ethernet controllers of a 1.2T card, use the following command:

```
RP/0/RP0/CPU0:ios# show controllers hundredGigECtrlr Rack/Slot/Instance/Port
```

Example

```
RP/0/RP0/CPU0:ios#show controllers hundredGigEctrlr 0/2/0/2
Wed Mar 30 06:56:58.878 UTC
Operational data for interface HundredGigEctrlr0/2/0/2:
State:
  Administrative state: enabled
  Operational state: Up
  LED state: Green On
  Maintenance: Disabled
  AINS Soak: None
    Total Duration: 0 hour(s) 0 minute(s)
    Remaining Duration: 0 hour(s) 0 minute(s) 0 second(s)
  Laser Squelch: Disabled
```

Insert Idle Ingress: Enabled

Insert Idle Egress: Enabled

```
Phy:
  Media type: Not known
  Statistics:
    FEC:
      Corrected Codeword Count: 0
      Uncorrected Codeword Count: 0
Autonegotiation disabled.
Operational values:
  Speed: 100Gbps
  Duplex: Full Duplex
  Flowcontrol: None
  Loopback: None (or external)
  BER monitoring:
    Not supported
  Forward error correction: Standard (Reed-Solomon)
  Holdoff Time: 0ms
```

Enable Idle Insertion on QXP Card

You can enable idle insertion on 100GE or 400GE controllers for the QXP card.

Configure Idle Insertion on 100GE Controllers

To configure idle insertion on the 100GE controllers for the QXP card, use the following commands:

configure

controller HundredGigEctrlr *Rack/Slot/Instance/Port*

holdoff-time trunk-fault *time-value*

commit

The range of *timevalue* is from 0 ms to 3000 ms.

The following is a sample where idle insertion is enabled on the 100GE controller for the QXP card.

```
RP/0/RP0/CPU0:ios#configure
RP/0/RP0/CPU0:ios(config)#controller HundredGigEctrlr 0/1/0/1
RP/0/RP0/CPU0:ios(config-eth-ctrlr)#holdoff-time trunk-fault 3000
RP/0/RP0/CPU0:ios(config-eth-ctrlr)#commit
```

The following is a sample to view the idle insertion status on the 100GE controller.

```

RP/0/RP0/CPU0:ios#show controller hundredGigEctrlr 0/1/0/1
Fri Jul 23 16:07:11.541 UTC
Operational data for interface HundredGigEctrlr0/1/0/1:

State:
  Administrative state: enabled
  Operational state: Up
  LED state: Green On
  Maintenance: Disabled
  AINS Soak: None
    Total Duration: 0 hour(s) 0 minute(s)
    Remaining Duration: 0 hour(s) 0 minute(s) 0 second(s)
  Laser Squelch: Enabled

Phy:
  Media type: Not known
Statistics:
FEC:
Corrected Codeword Count: 134967789
Uncorrected Codeword Count: 0

Autonegotiation disabled.

Operational values:
  Speed: 100Gbps
  Duplex: Full Duplex
  Flowcontrol: None
  Loopback: None (or external)
  BER monitoring:
    Not supported
    Forward error correction: Standard (Reed-Solomon)
  Holdoff Time: 3000ms

```

Configure Idle Insertion on 400GE Controllers

To configure idle insertion on the 400GE controllers for the QXP card, use the following commands:

```

configure
controller fourHundredGigEctrlr Rack/Slot/Instance/Port
holdoff-time trunk-fault time-value
commit

```

The following is a sample where idle insertion is enabled on the 400GE controller for the NCS1K4-QXP-K9 card.

```

RP/0/RP0/CPU0:ios#configure
RP/0/RP0/CPU0:ios(config)#controller fourHundredGigEctrlr 0/0/0/10
RP/0/RP0/CPU0:ios(config-eth-ctrlr)#holdoff-time trunk-fault 2000
RP/0/RP0/CPU0:ios(config-eth-ctrlr)#commit

```

The following is a sample to view the idle insertion status on the 400GE controller.

```

RP/0/RP0/CPU0:ios#show controller fourhundredGigEctrlr 0/0/0/10
Fri Jul 23 16:07:11.541 UTC
Operational data for interface fourHundredGigEctrlr0/0/0/10:

State:
  Administrative state: enabled

```

```

Operational state: Up
LED state: Green On
Maintenance: Disabled
AINS Soak: None
  Total Duration: 0 hour(s) 0 minute(s)
  Remaining Duration: 0 hour(s) 0 minute(s) 0 second(s)
Laser Squelch: Enabled

Phy:
  Media type: Not known
Statistics:
FEC:
Corrected Codeword Count: 134967789
Uncorrected Codeword Count: 0

Autonegotiation disabled.

Operational values:
  Speed: 400Gbps
  Duplex: Full Duplex
  Flowcontrol: None
  Loopback: None (or external)
  BER monitoring:
    Not supported
    Forward error correction: Standard (Reed-Solomon)
Holdoff Time: 2000ms

```

FlexO GID and IID

The 2.4T and 2.4TX cards use flexible OTN (flexO) interfaces on trunk ports. These flexO interfaces provide a flexible and interoperable mechanism to transport OTU signals by grouping standard lower rate interfaces. Each flexO interface group is identified by a flexO group identification (GID) number, which ranges 1–1,048,576. Each member of a flexO group is identified by a flexO instance identification (IID) number. The IID cannot be changed.

Configuring FlexO GID

To configure flexO GID and IID on the coherentDSP controller, enter the following commands:

```

configure
controller coherentDSP R/S/I/P
flexo
gid <gid-no>
commit

```

The following sample shows how to configure flexO GID on the CoherentDSP controller:

```

P/0/RP0/CPU0:ios#configure terminal
Mon Feb  5 05:14:42.919 UTC
RP/0/RP0/CPU0:ios(config)#controller coherentDSP 0/0/0/0
RP/0/RP0/CPU0:ios(config-CoDSP)#flexo gid 1048575
RP/0/RP0/CPU0:ios(config-CoDSP)#commit

```

Verifying FlexO GID

The following sample shows the flexO GID configuration on the CoherentDSP controller:

```

RP/0/RP0/CPU0:ios#show controllers coherentDSP 0/0/0/0
Mon Feb  5 05:20:01.660 UTC

Port                               : CoherentDSP 0/0/0/0
Controller State                    : Up
Inherited Secondary State          : Normal
Configured Secondary State        : Normal
Derived State                      : In Service
Loopback mode                      : None
BER Thresholds                    : SF = 1.0E-5  SD = 1.0E-7
Performance Monitoring             : Enable
Bandwidth                          : 1200.0Gb/s

Alarm Information:
LOS = 1 LOF = 0 LOM = 0
OOF = 0 OOM = 0 AIS = 0
IAE = 0 BIAE = 0          SF_BER = 0
SD_BER = 0          BDI = 0 TIM = 0
FECMISMATCH = 0 FEC-UNC = 1          FLEXP_GIDM = 0
FLEXP-MM = 0          FLEXP-LOM = 0  FLEXP-RDI = 0
FLEXP-LOF = 0
Detected Alarms                   : None

Bit Error Rate Information
PREFEC BER                        : 1.23E-02
POSTFEC BER                       : 0.00E+00
Q-Factor                          : 7.00 dB

Q-Margin                          : 0.80 dB

Instantaneous Q-Margin            : 0.80 dB

TTI :
    Remote hostname                : ios
    Remote interface               : CoherentDSP 0/0/0/7
    Remote IP addr                 : 0.0.0.0

FEC mode                          : Soft-Decision 15

Flexo-Mode                        : Enable
Flexo Details:
    Tx GID                        : 1
    TX IID                        : 1, 2, 3, 4, 5, 6, 7, 8, 9, 10, 11, 12,
    Rx GID                        : 1
    RX IID                        : 1, 2, 3, 4, 5, 6, 7, 8, 9, 10, 11, 12,

AINS Soak                        : None
AINS Timer                       : 0h, 0m
AINS remaining time              : 0 seconds

```

Link Layer Discovery Protocol (LLDP) Support on Management Interface

The LLDP can be configured on management interface of 1.2T, 2.4T, and 2.4TX cards. It requires a system to form LLDP neighborhood over the system management interface, through which it advertises and learns LLDP neighbor information. This information about neighbors is used to learn about the neighbors and in turn the topology of the devices for Operations, Administration, and Maintenance (OAM) purposes.

Advantages of LLDP

- Provides support on non-Cisco devices.
- Enables neighbor discovery between non-Cisco devices.

Limitation

- When you disable LLDP globally, the LLDP gets disabled on all the interfaces.



Note By default, LLDP is enabled for NCS 1014. But when you enable and disable LLDP in the global configuration mode, LLDP gets disabled on all the interfaces.

Workaround: You must enable LLDP globally or reload the Router.

Cisco Discovery Protocol (CDP) vs LLDP

The CDP is a device discovery protocol that runs over Layer 2. Layer 2 is also known as the data link layer that runs on all Cisco devices, such as routers, bridges, access servers, and switches. This protocol allows the network management applications to automatically discover and learn about other Cisco devices that connect to the network.

The LLDP is also a device discovery protocol that runs over Layer 2. This protocol allows the network management applications to automatically discover and learn about other non-Cisco devices that connect to the network.

Interoperability between non-Cisco devices using LLDP

LLDP is also a neighbor discovery protocol that is used by network devices to advertise information about themselves to other devices on the network. This protocol runs over the data link layer, which allows two systems running different network layer protocols to learn about each other.

With LLDP, the user can also access the information about a particular physical network connection. If the user uses a non-Cisco monitoring tool (through SNMP), LLDP helps you identify the Object Identifiers (OIDs) that the system supports. The following OIDs are supported:

- 1.0.8802.1.1.2.1.4.1.1.4
- 1.0.8802.1.1.2.1.4.1.1.5
- 1.0.8802.1.1.2.1.4.1.1.6
- 1.0.8802.1.1.2.1.4.1.1.7
- 1.0.8802.1.1.2.1.4.1.1.8
- 1.0.8802.1.1.2.1.4.1.1.9
- 1.0.8802.1.1.2.1.4.1.1.10
- 1.0.8802.1.1.2.1.4.1.1.11
- 1.0.8802.1.1.2.1.4.1.1.12

Neighbor Discovery

System advertises the LLDP TLV (Type Length Value) details over the management network using which other devices in the management network can learn about this device.

Configuring LLDP

- LLDP full stack functionality is supported on all three management interfaces supported in NCS 1014.
- You can selectively enable or disable LLDP on any of the management interfaces on demand.
- You can selectively enable or disable LLDP transmit or receive functionality at the management interface level.
- Information gathered using LLDP can be stored in the device Management Information Database (MIB) and queried with the Simple Network Management protocol (SNMP).
- LLDP operational data are available in both Command Line Interface and netconf-yang interface.

Enabling LLDP Globally

When you enable LLDP globally, all interfaces that support LLDP are automatically enabled for both transmit and receive operations.



Note You can override this default operation at the interface to disable receive or transmit operations.

The following table describes the global LLDP attributes that the user can configure:

Table 2:

Attribute	Default	Range	Description
Holdtime	120	0–65535	Specifies the hold time (in sec). Hold time refers to the time or duration that an LLDP device maintains the neighbor information before discarding.
Reinit	2	2–5	Delay (in sec) for LLDP initialization on any interface
Timer	30	5-65534	Specifies the rate at which LLDP packets are sent (in sec)

The following example shows the commands to configure LLDP globally. The global LLDP configuration enables LLDP on all the three management interfaces.

```
RP/0/RP0/CPU0:regen#configure terminal
RP/0/RP0/CPU0:regen(config)#lldp management enable
RP/0/RP0/CPU0:regen(config)#lldp holdtime 30
RP/0/RP0/CPU0:regen(config)#lldp reinit 2
RP/0/RP0/CPU0:regen(config)#commit
```

Verification

You can verify the LLDP configuration using the **show running-config lldp** command.

The output of **show running-config lldp** command is as follows:

```
RP/0/RP0/CPU0:regen#show running-config lldp
Tue Dec 10 10:36:11.567 UTC
lldp
timer 30
reinit 2
holdtime 120
management enable
!
```

You can verify the LLDP data using the **show lldp interface** and **show lldp neighbors** commands.

The output of **show lldp interface** command is as follows:

```
RP/0/RP0/CPU0:regen#show lldp interface
Thu Nov 7 08:45:22.934 UTC

MgmtEth0/RP0/CPU0/0:
    Tx: enabled
    Rx: enabled
    Tx state: IDLE
    Rx state: WAIT FOR FRAME

MgmtEth0/RP0/CPU0/1:
    Tx: enabled
    Rx: enabled
    Tx state: IDLE
    Rx state: WAIT FOR FRAME
```

The output of **show lldp neighbors** command is as follows:

```
RP/0/RP0/CPU0:M-131#show lldp neighbors
Mon Dec 2 11:01:20.143 CET
Capability codes:
    (R) Router, (B) Bridge, (T) Telephone, (C) DOCSIS Cable Device
    (W) WLAN Access Point, (P) Repeater, (S) Station, (O) Other

Device ID          Local Intf          Hold-time  Capability  Port ID
[DISABLED]         MgmtEth0/RP0/CPU0/0  120        B           gi19
MYS-130            MgmtEth0/RP0/CPU0/1  120        R           MgmtEth0/RP0/CPU0/1
```

where [DISABLED] shows that the LLDP is disabled on the interface MgmtEth0/RP0/CPU0/0.

Enabling LLDP per Management Interface

The following example shows the commands to configure LLDP at the management interface level.

```
RP/0/RP0/CPU0:ios(config)#interface mgmtEth 0/RP0/CPU0/X
RP/0/RP0/CPU0:ios(config-if)#lldp enable
RP/0/RP0/CPU0:ios(config-if)#commit
```

Disabling LLDP Transmit and Receive Operations

The following example shows the commands to disable the LLDP transmit operations at the specified management interface.

```
RP/0/RP0/CPU0:ios(config)#interface mgmtEth 0/RP0/CPU0/X
RP/0/RP0/CPU0:ios(config-if)#lldp transmit disable
RP/0/RP0/CPU0:ios(config-if)#commit
```

The following example shows the commands to disable the LLDP receive operations at the specified management interface.

```
RP/0/RP0/CPU0:ios(config)#interface mgmtEth 0/RP0/CPU0/X
RP/0/RP0/CPU0:ios(config-if)#lldp receive disable
RP/0/RP0/CPU0:ios(config-if)#commit
```

Debugging LLDP Issues

The following commands are used for debugging issues in the LLDP functionality.

- **show lldp traffic**
- **debug lldp all**
- **debug lldp errors**
- **debug lldp events**
- **debug lldp packets**
- **debug lldp tlvs**
- **debug lldp trace**
- **debug lldp verbose**

MAC Address Snooping on Client Ports

MAC address snooping allows you to learn the MAC address of the neighbor on 1.2T cards, that is connected to the client ports. You can enable ARP snooping on all client ports and learn the MAC address of neighbors through CLI.

This feature overcomes the limitation, where LLDP (Link Layer Discovery protocol) cannot be enabled in some networks.

Limitations

- When you enable or disable MAC address snooping on any slice, few packets are dropped during configuration.
- Open config interface for enabling or disabling MAC address snooping is not supported.
- SNMP MIB is not supported for the MAC address attribute.



Note When you enable MAC address snooping on client ports, it overrides LLDP.

Configuring MAC Address Snooping on Client Ports

You can configure MAC address or ARP snoop on slice in Muxponder slice mode using the following commands.

configure

hw-module location *location* **mxponder-slice** *slice-number*

client-rate 100GE

```
trunk-rate 600G { 100G | 150G | 200G | 250G | 300G | 350G | 400G | 450G | 500G | 550G | 600G }
```

```
arp-snoop
```

```
commit
```

Example

The following is a sample in which, MAC address or ARP snoop is configured on the client ports of slice 0 in Muxponder slice mode.

```
RP/0/RP0/CPU0:ios#configure
Mon Mar 16 19:30:33.933 UTC
RP/0/RP0/CPU0:ios(config)#hw-module location 0/3/nxr0 mxponder-slice 0
RP/0/RP0/CPU0:ios(config-hwmod-mxp)#client-rate 100GE
RP/0/RP0/CPU0:ios(config-hwmod-mxp)#trunk-rate 600G
RP/0/RP0/CPU0:ios(config-hwmod-mxp)#arp-snoop
RP/0/RP0/CPU0:ios(config-hwmod-mxp)#commit
Mon Mar 16 19:30:52.636 UTC
RP/0/RP0/CPU0:ios(config-hwmod-mxp)#end
```

The following is a sample in which, MAC address or ARP snoop is configured in Muxponder mode.

```
RP/0/RP0/CPU0:ios#configure
Mon Mar 16 19:08:17.154 UTC
RP/0/RP0/CPU0:ios(config)#hw-module location 0/1 mxponder arp-snoop
RP/0/RP0/CPU0:ios(config)#commit
```

The following sample shows the output of **show controllers hundredGigEctrlr** command, before configuring MAC address or ARP snoop on client ports.

```
RP/0/RP0/CPU0:ios#show controllers HundredGigEctrlr 0/1/0/2/1
Mon Mar 16 19:40:37.434 UTC
Operational data for interface HundredGigEctrlr0/1/0/2/1:

State:
  Administrative state: enabled
  Operational state: Up
  LED state: Green On
  Maintenance: Disabled
  AINS Soak: None
    Total Duration: 0 hour(s) 0 minute(s)
    Remaining Duration: 0 hour(s) 0 minute(s) 0 second(s)
  Laser Squelch: Disabled

Phy:
  Media type: Not known

Autonegotiation disabled.

Operational values:
  Speed: 100Gbps
  Duplex: Full Duplex
  Flowcontrol: None
  Loopback: None (or external)
  BER monitoring:
    Not supported
  Holdoff Time: 0ms
```

Viewing Neighbor MAC Address

You can view the neighbor's physical address after enabling MAC address or ARP snoop using the following command. MAC address snoop output is enabled after ARP packets are received on the respective 100G client.

show controllers hundredGigEctrlr R/S/I/P

The following sample shows the neighbor's MAC address after configuring MAC address or ARP snoop on client ports.

```
RP/0/RP0/CPU0:ios#show controllers HundredGigEctrlr 0/1/0/2/1
Mon Mar 16 19:41:08.047 UTC
Operational data for interface HundredGigEctrlr0/1/0/2/1:

State:
  Administrative state: enabled
  Operational state: Up
  LED state: Green On
  Maintenance: Disabled
  AINS Soak: None
    Total Duration: 0 hour(s) 0 minute(s)
    Remaining Duration: 0 hour(s) 0 minute(s) 0 second(s)
  Laser Squelch: Disabled
  Neighbor Address:
    0010.9400.5502

Phy:
  Media type: Not known

Autonegotiation disabled.

Operational values:
  Speed: 100Gbps
  Duplex: Full Duplex
  Flowcontrol: None
```

Transmit Shutdown

Transmit shut on trunk optics controller brings down the CIM8 and PICO transmit power. You can configure transmit shut on optics controller of a 1.2T, 2.4TX, or 2.4T card.

Configuring Transmit Shutdown on Trunk Optics Controller

To perform transmit shutdown, enter the following commands:

```
RP/0/RP0/CPU0:ios#configure
RP/0/RP0/CPU0:chassisA164(config)#controller optics 0/1/0/0
RP/0/RP0/CPU0:chassisA164(config-Optics)#transmit-shutdown
RP/0/RP0/CPU0:chassisA164(config-Optics)#commit
RP/0/RP0/CPU0:ios(config-Optics)#exit
RP/0/RP0/CPU0:ios(config)#exit
```

Verifying Transmit Shutdown on Trunk Optics Controller

To verify the transmit shutdown details on the trunk optics controller, use the following command:

show controllers optics R/S/I/P**Example**

Following is an example to view the transmit shutdown details:

```
RP/0/RP0/CPU0:ios#show controllers optics 0/0/0/0
Tue Dec 12 05:38:32.416 UTC

Controller State: Up

Transport Admin State: In Service

Laser State: Off

LED State: Green

Optics Status
  Optics Type: CIM8 DWDM
  DWDM carrier Info: C BAND, MSA ITU Channel=61, Frequency=193.10THz,
  Wavelength=1552.524nm

  Alarm Status:
  -----
  Detected Alarms: None

  LOS/LOL/Fault Status:

  Alarm Statistics:

  -----
  HIGH-RX-PWR = 0          LOW-RX-PWR = 0
  HIGH-TX-PWR = 0          LOW-TX-PWR = 2
  HIGH-LBC = 0            HIGH-DGD = 0
  OOR-CD = 0              OSNR = 1
  WVL-OOL = 0            MEA = 0
  IMPROPER-REM = 0
  TX-POWER-PROV-MISMATCH = 0
  Laser Bias Current = 0.0 %
  Actual TX Power = -40.00 dBm
  RX Power = -6.60 dBm
  RX Signal Power = -7.06 dBm
  Frequency Offset = -846 MHz

  Performance Monitoring: Enable

  THRESHOLD VALUES
  -----

  Parameter                High Alarm  Low Alarm  High Warning  Low Warning
  -----
  Rx Power Threshold(dBm)   13.0       -17.0     0.0           0.0
  Tx Power Threshold(dBm)   5.0        -13.0     0.0           0.0
  LBC Threshold(mA)         N/A        N/A       0.00          0.00

  LBC High Threshold = 90 %
  Configured Tx Power = 2.00 dBm
  Configured CD High Threshold = 180000 ps/nm
  Configured CD lower Threshold = -180000 ps/nm
  Configured OSNR lower Threshold = 20.50 dB
  Configured DGD Higher Threshold = 90.00 ps
  Baud Rate = 137.9783780000 GBd
```

```

Bits per Symbol = 3.5200000000 bits/symbol
Modulation Type: PCS
Chromatic Dispersion 0 ps/nm
Configured CD-MIN -10000 ps/nm CD-MAX 48000 ps/nm
Polarization Mode Dispersion = 0.0 ps
Second Order Polarization Mode Dispersion = 9.00 ps^2
Optical Signal to Noise Ratio = 36.90 dB
SNR = 16.10 dB
Polarization Dependent Loss = 0.90 dB
Polarization Change Rate = 0.00 rad/s
Differential Group Delay = 1.00 ps
Filter Roll Off Factor : 0.100
Rx VOA Target Power : -2.0 dBm
NLEQ Compensation Mode : 0
Cross Polarization Gain Mode : 10
Proprietary Submarine Parameters
  Type : 1      Value : 0
  Type : 2      Value : 0
  Type : 3      Value : 0
  Type : 4      Value : 0
  Type : 5      Value : 10485760

```

Transceiver Vendor Details

```

Form Factor      : CIM8
Name             : CISCO-ACACIA
Serial Number    : N/A
PID              : CIM8-C-K9
VID              : N/A
Date Code (yy/mm/dd) : 23/10/20
Fiber Connector Type: LC
Otn Application Code: Not Set
Sonet Application Code: Not Set
Ethernet Compliance Code: Not set

```

Transceiver Temperature : 38 Celsius

```

AINS Soak      : None
AINS Timer     : 0h, 0m
AINS remaining time : 0 seconds

```

Loopback

You can configure loopback on the CoherentDSP and Ethernet controllers of QXP, 1.2T, 24TX and 2.4T cards to identify connection problems. The loopback can be configured only in the maintenance mode. Use the **controller *controller-type*** and the **secondary-admin-state maintenance** commands to place the controllers in the maintenance mode.

Loopback configuration alarm details for each controller are triggered whenever there is a change in the loopback configuration. Details such as, location of the controller, severity, configuration date and time, and description are available in the output of the **show alarms brief system active** and **show alarms brief history** commands.

Configuring Loopback on the 1.2T Card

To configure the loopback on a 1.2T card, use the following commands:

```
controller controllertype Rack/Slot/Instance/Port
```

sec-admin-state maintenance

loopback [internal]



Note Line loopback is not supported on CoherentDSP controller of 1.2T card.

Configuring Loopback on 2.4T Card and 2.4TX Card

To configure the loopback on 2.4T card and 2.4TX card, use the following commands:

```
controller {HundredGigECtrlr Rack/Slot/Instance/Port/Lane |
fourHundredGigECtrlr Rack/Slot/Instance/Port}
```

sec-admin-state maintenance

loopback [line | internal]



Note In case of muxponder configuration on the 2.4TX card, internal loopback must be applied on both trunk ports for the loopback behaviour to reflect on the split ports. For direct ports, the corresponding trunk internal loopback works as expected.

Example 1

The following example shows how a internal loopback is configured on the Ethernet controller of a 1.2T card.

```
RP/0/RP0/CPU0:ios#configure
RP/0/RP0/CPU0:ios(config)#controller HundredGigECtrlr 0/1/0/1
RP/0/RP0/CPU0:ios(config-eth-ctrlr)#sec-admin-state maintenance
RP/0/RP0/CPU0:ios(config-eth-ctrlr)#loopback internal
RP/0/RP0/CPU0:ios(config-eth-ctrlr)#commit
RP/0/RP0/CPU0:ios(config)#exit
```

Example 2

The following example shows how a line loopback is configured on coherentDSP controller of a 2.4T card and 2.4TX card.

```
RP/0/RP0/CPU0:ios#configure
RP/0/RP0/CPU0:ios(config)#controller coherentDSP 0/1/0/0
RP/0/RP0/CPU0:ios(config-eth-ctrlr)#sec-admin-state maintenance
RP/0/RP0/CPU0:ios(config-eth-ctrlr)#loopback line
RP/0/RP0/CPU0:ios(config-eth-ctrlr)#commit
RP/0/RP0/CPU0:ios(config)#exit
```

Example 3

The following example shows how to verify an internal loopback configured on the Ethernet controller of I.2T card.

```
RP/0/RP0/CPU0:ios#show controller HundredGigEctr1r 0/1/0/1
Fri Nov 17 10:01:22.840 UTC
Operational data for interface HundredGigEctr1r0/1/0/1:

State:
  Administrative state: enabled
  Operational state: Up
  LED state: Green On
  Maintenance: Enabled
  AINS Soak: None
    Total Duration: 0 hour(s) 0 minute(s)
    Remaining Duration: 0 hour(s) 0 minute(s) 0 second(s)
  Laser Squelch: Disabled
  Insert Idle Ingress: Disabled
  Insert Idle Egress: Disabled

Phy:
  Media type: Not known
  Statistics:
    FEC:
      Corrected Codeword Count: 72671614           Valid: True      Start time:
15:53:12 Thu Nov 16 2023
      Uncorrected Codeword Count: 12             Valid: True      Start time:
15:53:12 Thu Nov 16 2023
    PCS:
      Total BIP errors: 0                       Valid: True      Start time:
15:53:12 Thu Nov 16 2023
      Total frame errors: 0                   Valid: False     Start time:
15:53:12 Thu Nov 16 2023
      Total Bad SH: 0                         Valid: False     Start time:
15:53:12 Thu Nov 16 2023

Autonegotiation disabled.

Operational values:
  Speed: 400Gbps
  Duplex: Full Duplex
  Flowcontrol: None
  Loopback: Internal
  BER monitoring:
    Not supported
  Forward error correction: Standard (Reed-Solomon)
  Holdoff Time: 0ms
```

Configuring Loopback on the QXP Card

Example 1

The following example shows how to configure internal loopback on a coherent DSP controller.

```
RP/0/RP0/CPU0:ios#configure
Fri Jul 8 10:42:51.329 UTC
RP/0/RP0/CPU0:ios(config)#controller coherentDSP 0/0/0/0
RP/0/RP0/CPU0:ios(config-CoDSP)#secondary-admin-state maintenance
RP/0/RP0/CPU0:ios(config-CoDSP)#loopback internal
RP/0/RP0/CPU0:ios(config-CoDSP)#commit
```

```
Fri Jul 8 10:43:48.644 UTC
RP/0/RP0/CPU0:ios(config-CoDSP)#end
```

The following example shows how to verify the internal loopback configured on a coherent DSP controller.

```
RP/0/RP0/CPU0:ios#show controllers coherentDSP 0/0/0/0
Fri Jul 8 10:45:53.820 UTC
Port : CoherentDSP 0/0/0/0
Controller State : Down
Inherited Secondary State : Normal
Configured Secondary State : Maintenance
Derived State : Maintenance
Loopback mode : Internal
BER Thresholds : SF = 1.0E-5 SD = 1.0E-7
Performance Monitoring : Enable
Bandwidth : 400.0Gb/s
Alarm Information:
LOS = 2 LOF = 0 LOM = 0
OOF = 0 OOM = 0 AIS = 0
IAE = 0 BIAE = 0 SF_BER = 0
SD_BER = 0 BDI = 0 TIM = 0
FECMISMATCH = 0 FEC-UNC = 0 FLEXO_GIDM = 0
FLEXO-MM = 0 FLEXO-LOM = 0 FLEXO-RDI = 0
FLEXO-LOF = 0
Detected Alarms : LOS
Bit Error Rate Information
PREFEC BER : 5.00E-01
POSTFEC BER : 0.00E+00
Q-Factor : 0.00 dB
Q-Margin : 0.00dB
OTU TTI Received
FEC mode : C_FEC
Flexo-Mode : Enable
Flexo Details:
Tx GID : 0
Rx GID : 0
AINS Soak : None
AINS Timer : 0h, 0m
AINS remaining time : 0 seconds
```

Example 2

The following example shows how to configure line loopback on a coherent DSP controller.

```
RP/0/RP0/CPU0:ios#configure
Fri Jul 8 10:48:48.577 UTC
RP/0/RP0/CPU0:ios(config)#controller coherentDSP 0/0/0/0
RP/0/RP0/CPU0:ios(config-CoDSP)#secondary-admin-state maintenance
RP/0/RP0/CPU0:ios(config-CoDSP)#loopback line
RP/0/RP0/CPU0:ios(config-CoDSP)#commit
Fri Jul 8 10:49:26.809 UTC
RP/0/RP0/CPU0:ios(config-CoDSP)#end
```

The following example shows how to verify the line loopback configured on a coherent DSP controller.

```
RP/0/RP0/CPU0:ios#show controllers coherentDSP 0/0/0/0
Fri Jul 8 10:49:44.073 UTC
Port : CoherentDSP 0/0/0/0
Controller State : Down
Inherited Secondary State : Normal
Configured Secondary State : Maintenance
Derived State : Maintenance
Loopback mode : Line
BER Thresholds : SF = 1.0E-5 SD = 1.0E-7
Performance Monitoring : Enable
```

```

Bandwidth : 400.0Gb/s
Alarm Information:
LOS = 2 LOF = 0 LOM = 0
OOF = 0 OOM = 0 AIS = 0
IAE = 0 BIAE = 0 SF_BER = 0
SD_BER = 0 BDI = 0 TIM = 0
FECMISMATCH = 0 FEC-UNC = 0 FLEXO_GIDM = 0
FLEXO-MM = 0 FLEXO-LOM = 0 FLEXO-RDI = 0
FLEXO-LOF = 0
Detected Alarms : LOS
Bit Error Rate Information
PREFEC BER : 5.00E-01
POSTFEC BER : 0.00E+00
Q-Factor : 0.00 dB
Q-Margin : 0.00dB
OTU TTI Received
FEC mode : C_FEC
Flexo-Mode : Enable
Flexo Details:
Tx GID : 0
Rx GID : 0
AINS Soak : None
AINS Timer : 0h, 0m
AINS remaining time : 0 seconds

```

Example 3

The following example shows how to configure internal loopback on the 400GE controller.

```

RP/0/RP0/CPU0:ios#configure
Fri Jul 8 11:19:26.286 UTC
RP/0/RP0/CPU0:ios(config)#controller FourHundredGigECtrlr 0/0/0/3
RP/0/RP0/CPU0:ios(config-eth-ctrlr)#sec-admin-state maintenance
RP/0/RP0/CPU0:ios(config-eth-ctrlr)#loopback internal
RP/0/RP0/CPU0:ios(config-eth-ctrlr)#commit
Fri Jul 8 11:19:47.496 UTC
RP/0/RP0/CPU0:ios(config-eth-ctrlr)#end

```

The following example shows how to verify the internal loopback configured on the 400GE controller.

```

RP/0/RP0/CPU0:ios#show controllers FourHundredGigECtrlr 0/0/0/3
Fri Jul 8 11:19:59.597 UTC
Operational data for interface FourHundredGigECtrlr0/0/0/3:
State:
Administrative state: enabled
Operational state: Down (Reason: State undefined)
LED state: Red On
Maintenance: Enabled
AINS Soak: None
Total Duration: 0 hour(s) 0 minute(s)
Remaining Duration: 0 hour(s) 0 minute(s) 0 second(s)
Laser Squelch: Disabled
Insert Idle Ingress: Disabled
Insert Idle Egress: Disabled
Phy:
Media type: Not known
Alarms:
Current:
Loss of Signal
Statistics:
FEC:
Corrected Codeword Count: 702710
Uncorrected Codeword Count: 1147
Autonegotiation disabled.

```

```
Operational values:
Speed: 400Gbps
Duplex: Full Duplex
Flowcontrol: None
Loopback: Internal
BER monitoring:
Not supported
Forward error correction: Standard (Reed-Solomon)
Holdoff Time: 0ms
```

Example 4

The following example shows how to configure line loopback on the 4X100GE MXP.

```
RP/0/RP0/CPU0:ios(config)#controller hundredGigEctrler 0/3/0/1/1
RP/0/RP0/CPU0:ios(config-eth-ctrlr)#loopback line
RP/0/RP0/CPU0:ios(config-eth-ctrlr)#sec-admin-state maintenance
RP/0/RP0/CPU0:ios(config-eth-ctrlr)#commit
```

The following example shows how to verify the line loopback configured on the 4X100GE MXP.

```
RP/0/RP0/CPU0:ios#sh controllers hundredGigEctrler 0/3/0/1/1
Fri Jul 22 10:34:39.730 UTC
Operational data for interface HundredGigEctrler0/3/0/1/1:
```

State:

```
Administrative state: enabled
Operational state: Up
LED state: Green On
Maintenance: Enabled
AINS Soak: None
  Total Duration: 0 hour(s) 0 minute(s)
  Remaining Duration: 0 hour(s) 0 minute(s) 0 second(s)
Laser Squelch: Disabled
Insert Idle Ingress: Disabled
Insert Idle Egress: Disabled
```

Phy:

```
Media type: Not known
Statistics:
  FEC:
    Corrected Codeword Count: 6110368          Valid: True      Start time:
13:10:41 Thu Jul 21 2022
    Uncorrected Codeword Count: 2771          Valid: True      Start time:
13:10:41 Thu Jul 21 2022
  PCS:
    Total BIP errors: 63700992                Valid: True      Start time:
13:10:41 Thu Jul 21 2022
    Total frame errors: 0                     Valid: False     Start time:
13:10:41 Thu Jul 21 2022
    Total Bad SH: 0                           Valid: False     Start time:
13:10:41 Thu Jul 21 2022
```

Autonegotiation disabled.

```
Operational values:
Speed: 100Gbps
Duplex: Full Duplex
Flowcontrol: None
Loopback: Line
BER monitoring:
Not supported
Forward error correction: Standard (Reed-Solomon)
Holdoff Time: 0ms
```

Example 5

The following example shows how to configure internal loopback on the 4X100GE MXP.

```
RP/0/RP0/CPU0:ios#conf
RP/0/RP0/CPU0:ios(config)#controller hundredGigEctrlr 0/3/0/7/1
RP/0/RP0/CPU0:ios(config-eth-ctrlr)#sec-admin-state maintenance
RP/0/RP0/CPU0:ios(config-eth-ctrlr)#loopback internal
RP/0/RP0/CPU0:ios(config-eth-ctrlr)#commit
```

The following example shows how to verify the internal loopback configured on the 4X100GE MXP.

```
RP/0/RP0/CPU0:ios#show controller HundredGigEctrlr 0/3/0/7/1
Fri Jul 22 10:40:34.928 UTC
```

Operational data for interface HundredGigEctrlr0/3/0/7/1:

State:

```
Administrative state: enabled
Operational state: Down (Reason: State undefined)
LED state: Red On
Maintenance: Enabled
AINS Soak: None
  Total Duration: 0 hour(s) 0 minute(s)
  Remaining Duration: 0 hour(s) 0 minute(s) 0 second(s)
Laser Squelch: Disabled
Insert Idle Ingress: Disabled
Insert Idle Egress: Disabled
```

Phy:

```
Media type: Not known
Alarms:
```

```
Current:
  Loss of Signal
```

Statistics:

```
FEC:
  Corrected Codeword Count: 31426046
  Uncorrected Codeword Count: 2187
```

Autonegotiation disabled.

Operational values:

```
Speed: 100Gbps
Duplex: Full Duplex
Flowcontrol: None
Loopback: Internal
BER monitoring:
  Not supported
Forward error correction: Standard (Reed-Solomon)
Holdoff Time: 0ms
```

Viewing Loopback Configuration Alarm

The following example shows how to view the loopback configuration alarms.

```
RP/0/RP0/CPU0:ios#show alarms brief system active
Tue Sep 13 17:43:35.212 UTC
```

```
-----
Active Alarms
-----
```

Location	Severity	Group	Set Time	Description
----------	----------	-------	----------	-------------

```

-----
0/2          Minor      Controller      09/13/2022 17:34:32 UTC
HundredGigECtrlr0/2/0/2 - Internal Loopback Configured
0/2          Minor      Controller      09/13/2022 17:34:32 UTC
HundredGigECtrlr0/2/0/2 - Internal Loopback Configured
0/2          Minor      Controller      09/13/2022 17:34:32 UTC
HundredGigECtrlr0/2/0/2 - Line Loopback Configured

0/2          Major      Ethernet        09/13/2022 17:34:31 UTC
HundredGigECtrlr0/2/0/1/2 - Loss of Synchronization The Data Interface

0/2          Minor      Controller      09/13/2022 17:39:19 UTC   CoherentDSP0/2/0/0
- Internal Loopback Configured

```

Restore Factory Settings



Note Perform this operation only on the console port.

You can restore the factory settings on the NCS 1014. The entire system configuration, including usernames, passwords, and IP addresses, is removed. You can perform this operation only through the console port and not on the management interface. To restore NCS 1014 to factory settings, use the **commit replace** command. After the **commit replace** operation completes, you must perform the IOS XR reload operation.

The **commit best-effort** command merges the target configuration with the running configuration and commits only valid changes (best effort). Some configuration changes might fail due to semantic errors.

Example

```

RP/0/RP0/CPU0:ios#configure
RP/0/RP0/CPU0:ios(config)#commit replace
Tue Sep 24 09:36:59.430 UTC

```

This commit will replace or remove the entire running configuration. This operation can be service affecting.

```

Do you wish to proceed? [no]: yes
RP/0/RP0/CPU0:ios(config)#exit
RP/0/RP0/CPU0:ios#reload
Tue Sep 24 09:38:12.881 UTC

```

Standby card not present or not Ready for failover. Proceed? [confirm]

Preparing system for backup. This may take a few minutes especially for large configurations.

```
Status report: node0_RP0_CPU0: BACKUP INPROGRESS
```

```
Status report: node0_RP0_CPU0: BACKUP HAS COMPLETED SUCCESSFULLY
```

[Done]

Proceed with reload? [confirm]

```

Reloading node 0/RP0/CPU0

RL: Reboot initiated with code 1, cause User initiated graceful reload reboot_timeout 30
shutdown delay 0
RL: Shutdown initiated
Query the node to be reloaded
  NODE_IP of noded to be reloaded 198.51.100.1
sending stop hb
Cause: User initiated graceful reload
VM IP addr sent for reload 198.51.100.1

Received ack from sdrmgr for reload request.Returncode:0
successful disconnection from service
wd_disconnect_cb 548 CMP-WD disconnected successfully
Invmgr successful disconnection from service

RP/0/RP0/CPU0:ios#
Disconnecting from 'default-sdr--1' console. Continue(Y/N)?

Connecting to 'default-sdr--1' console
ÿÿÿÿÿÿÿÿbootlogd: ioctl(/dev/pts/2, TIOCCONS): Device or resource busy
/sbin/restorecon: lstat(/etc/adjtime) failed: No such file or directory
Configuring network interfaces... done.
Starting system message bus: dbus.
Starting OpenBSD Secure Shell server: sshd
sshd start/running, process 1739
Starting rpcbind daemon...done.
Starting random number generator daemonUnable to open file: /dev/tpm0
.
Starting system log daemon...0
Starting kernel log daemon...0
tftpd-hpa disabled in /etc/default/tftpd-hpa
Starting internet superserver: xinetd.
net.ipv4.ip_forward = 1
Libvirt not initialized for container instance
Starting crond: OK
SIOCADDRT: File exists

DBG_MSG: platform type is 0
[*] ima_policy have loaded, or IMA policy file does not exist
Start serial incoming on , Clearing ..
RP/0/RP0/CPU0:Sep 24 09:38:44.284 UTC: fpd-serv[256]: %PKT_INFRA-FM-3-FAULT_MAJOR :
ALARM_MAJOR :FPD-NEED-UPGRADE :DECLARE :0/PM0:

This (D)RP Node is not ready or active for login /configuration
.....
.....
.....

ios con0/RP0/CPU0 is now available

Press RETURN to get started.

!!!!!!!!!!!!!!!!!!!!!! NO root-system username is configured. Need to configure root-system
username. !!!!!!!!!!!!!!!!!!!!!!!

```

Headless Mode

During process restarts, CPU reload, or removal of CPU, the NCS 1014 operates in headless mode for up to 72 hours. During this time, traffic is not impacted, although the control plane is not up and running. Fault

propagation continues to operate for failures on client and trunk ports. However, you cannot provision anything nor view operational data with a non-functional CPU. Performance monitoring data based on 15 minutes and 24 hour intervals is not supported with a non-functional CPU.

Trail Trace Identifier

The Trail trace identifier (TTI) feature helps you to identify the signal from the source to the destination within the network. You can configure the TTI sent or expected in ASCII and HEX. When the expected TTI string does not match the received TTI trace string, the controller goes down and the TIM alarm is raised. To configure TTI on the coherent DSP controllers of a 1.2T, 2.4T, or 2.4TX card, use the following commands:

configure

```
controller coherentDSP R/S/I/P tti {sent | expected} ascii | hextti-string
```

commit



Note The *tti-string* can have a maximum of 64 characters for ASCII and 128 characters for HEX.

The following sample displays how to configure TTI on a coherent DSP controller with the sent and expected strings set to the same ASCII string. The state of the controller is up.

```
RP/0/RP0/CPU0:ios#config
RP/0/RP0/CPU0:ios(config)#controller coherentDSP
RP/0/RP0/CPU0:ios(config-CoDSP)#tti sent ascii hello
RP/0/RP0/CPU0:ios(config-CoDSP)#tti expected ascii hello cisco
RP/0/RP0/CPU0:ios(config-CoDSP)#commit
Thu Dec 7 14:25:43.391 IST
RP/0/RP0/CPU0:ios(config-CoDSP)#end
```

The following is sample to view the TTI details on a coherentDSP controller.

```
RP/0/RP0/CPU0:ios#show controllers coherentDSP 0/3/0/0
Thu Dec 7 14:26:37.345 IST

Port : CoherentDSP 0/3/0/0
Controller State : Down
Inherited Secondary State : Normal
Configured Secondary State : Normal
Derived State : In Service
Loopback mode : None
BER Thresholds : SF = 1.0E-5 SD = 1.0E-7
Performance Monitoring : Enable
Bandwidth : 800.0Gb/s

Alarm Information:
LOS = 0 LOF = 0 LOM = 0
OOF = 0 OOM = 0 AIS = 0
IAE = 0 BIAE = 0 SF_BER = 0
SD_BER = 0 BDI = 0 TIM = 1
FECMISMATCH = 0 FEC-UNC = 0 FLEXO_GIDM = 0
FLEXO-MM = 0 FLEXO-LOM = 0 FLEXO-RDI = 0
FLEXO-LOF = 0
Detected Alarms : TIM

Bit Error Rate Information
PREFEC BER : 2.57E-04
POSTFEC BER : 0.00E+00
```



```

Q-Factor : 10.80 dB

Q-Margin : 4.50 dB

Instantaneous Q-Margin : 4.50 dB

OTU TTI Sent

FULL TTI ASCII STRING : hello

OTU TTI Received

FULL TTI ASCII STRING : hello

OTU TTI Expected

FULL TTI ASCII STRING : hello cisco

FEC mode : Soft-Decision 15

Flexo-Mode : Enable
Flexo Details:
Tx GID : 1
TX IID : 1, 2, 3, 4, 5, 6, 7, 8,
Rx GID : 1
RX IID : 1, 2, 3, 4, 5, 6, 7, 8,

AINS Soak : None
AINS Timer : 0h, 0m
AINS remaining time : 0 seconds
    
```

The following example shows how to configure TTI on a coherent DSP controller with the sent and expected strings set to HEX strings.

```

RP/0/RP0/CPU0:ios#config
RP/0/RP0/CPU0:ne(config)#controller coherentDSP 0/0/0/0
RP/0/RP0/CPU0:ne(config-CoDSP)#tti sent hex 6E6E6E2A2A2A
RP/0/RP0/CPU0:ne(config-CoDSP)#tti expected hex 3F4B4B4B3D3E3A
RP/0/RP0/CPU0:ne(config-CoDSP)#commit
RP/0/RP0/CPU0:ios(config)#exit
    
```

Configure TTI on QXP Card

You can configure the TTI sent or expected string in the full ASCII format, or Source Access Point Identifier (SAPI)/Destination Access Point Identifier (DAPI) format on ODU-flex, ODU4, and coherentDSP controllers for the QXP card.



Note TTI operates only in trunk mode OR.

The following table lists the ASCII format that is supported for TTI:

ASCII with Character String	Controller
Full ASCII 64-character	CoherentDSP,odu4,odu-flex

SAPI ASCII 15-character	CoherentDSP,odu4,odu-flex
DAPI ASCII 15-character	CoherentDSP,odu4,odu-flex
Operator-specific ASCII 32-character	CoherentDSP,odu4,odu-flex

To configure TTI, use the following commands:

configure

controller *controller-type R/S/I/P tti {sent | expected} {ascii | sapi ascii | dapi ascii | operator-specific ascii} tti-string*

commit

The following is a sample configuration for FULL TTI for coherentDSP controller

```
RP/0/RP0/CPU0:ios(config)#controller coherentDSP 0/0/0/8
RP/0/RP0/CPU0:ios(config-CoDSP)#tti sent ascii cisco
RP/0/RP0/CPU0:ios(config-CoDSP)#tti expected ascii cisco123
RP/0/RP0/CPU0:ios(config-CoDSP)#commit
```

The following is a sample configuration for TTI HEX for coherentDSP controller

```
RP/0/RP0/CPU0:ios(config)#controller coherentDSP 0/0/0/8
RP/0/RP0/CPU0:ios(config-CoDSP)#tti sent hex 6E6E6E2A2A2A
RP/0/RP0/CPU0:ios(config-CoDSP)#tti expected hex 3F4B4B4B3D3E3A
RP/0/RP0/CPU0:ios(config-CoDSP)#commit
```

The following is a sample configuration for Operator specific TTI for coherentDSP controller

```
RP/0/RP0/CPU0:ios(config)#controller coherentDSP 0/0/0/8
RP/0/RP0/CPU0:ios(config-CoDSP)#tti sent operator-specific ascii hellooo
RP/0/RP0/CPU0:ios(config-CoDSP)#tti expected operator-specific ascii hellooo
RP/0/RP0/CPU0:ios(config-CoDSP)#commit
```

The following is a sample configuration for Operator specific TTI HEX for coherentDSP controller

```
RP/0/RP0/CPU0:ios(config)#controller coherentDSP 0/0/0/8
RP/0/RP0/CPU0:ios(config-CoDSP)#tti sent operator-specific hex
6E6E6E2A2A2A3D3E3A3A6E6E2A2A2A3D
RP/0/RP0/CPU0:ios(config-CoDSP)#tti expected operator-specific hex 5A5A6D3A3B3C3F4B4B4B3D3E3A
RP/0/RP0/CPU0:ios(config-CoDSP)#commit
```

The following is a sample configuration for SAPI for coherentDSP controller

```
RP/0/RP0/CPU0:ios(config)#controller coherentDSP 0/0/0/8
RP/0/RP0/CPU0:ios(config-CoDSP)#tti sent operator-specific ascii hellooo
RP/0/RP0/CPU0:ios(config-CoDSP)#tti expected operator-specific ascii hellooo
RP/0/RP0/CPU0:ios(config-CoDSP)#commit
```

The following is a sample configuration for DAPI for coherentDSP controller

```
RP/0/RP0/CPU0:ios(config)#controller coherentDSP 0/0/0/8
RP/0/RP0/CPU0:ios(config-CoDSP)#tti sent dapi ascii cisco123
RP/0/RP0/CPU0:ios(config-CoDSP)#tti expected dapi ascii hello
RP/0/RP0/CPU0:ios(config-CoDSP)#commit
```

Chromatic Dispersion

You can configure chromatic dispersion on optics controllers of 1.2T, 2.4TX, and 2.4T cards. When you configure the maximum and minimum values for chromatic dispersion for any data rate, ensure the minimum difference between the configured values is equal to or greater than 1500 ps/nm.

The following table lists the default CD search range for a 1.2T card.

Data Rate	BPS	Card Support	Default CD Search Range
200G to 500G	BPS <= 3	1.2T, 1.2TL	-10,000 to 100,000 ps/nm
	3 < BPS <= 4	1.2T, 1.2TL	-10,000 to 80,000 ps/nm
	4 < BPS <=5	1.2T	-5,000 to 20,000 ps/nm
600G	BPS=5.2578125	1.2T	-2000 to 2,000 ps/nm

The following table lists the default CD search range for 2.4T, 2.4TX, cards.

Line Rate				
	138GBd	128GBd	118GBd	108GBd
1200G	4000 to -5000	4000 to -5000	—	—
1000G	20000 to -5000	20000 to -5000	20000 to -5000	—
800G	48000 to -10000	48000 to -10000	48000 to -10000	35000 to -10000
600G	74000 to -10000	74000 to -10000	74000 to -10000	60000 to -10000
500G	90000 to -10000	90000 to -10000	90000 to -10000	72000 to -10000
400G	—	90000 to -10000	90000 to -10000	72000 to -10000



Note The cd-min and cd-max values must be set for BPS values that are greater than 4 in the 1.2T card.



Note When the user provisions the cd-min and cd-max values that are outside the range through CLI, the provisioned values are accepted; however, only the actual values supported by the hardware are applied.

The following is a sample where chromatic dispersion is configured on the optics controller.

```
RP/0/RP0/CPU0:ios#configure
Mon Aug 19 19:31:42.115 UTC
RP/0/RP0/CPU0:ios(config)#controller optics 0/1/0/1
RP/0/RP0/CPU0:ios(config-Optics)#cd-max 4000
RP/0/RP0/CPU0:ios(config-Optics)#cd-min -1000
RP/0/RP0/CPU0:ios(config-Optics)#commit
Mon Aug 19 19:35:24.697 UTC
```

```

RP/0/RP0/CPU0:ios(config-Optics)#exit
RP/0/RP0/CPU0:ios(config)#exit

RP/0/RP0/CPU0:ios#show run controller optics 0/1/0/*
Mon Aug 19 19:57:41.859 UTC
controller Optics0/1/0/0
  transmit-power -15
  dwdm-carrier 50GHz-grid itu-ch 55
  enh-sop-tol-mode 1
  cross-pol-gain-mode 10
  lbc-high-threshold 5
!
controller Optics0/1/0/1
  description trunk power UP
  cd-min -1000
  cd-max 4000
  enh-colorless-mode 2
  enh-sop-tol-mode 3
  nleq-comp-mode 4
  cross-pol-gain-mode 2
  cross-pol-weight-mode 3
  cpr-win-mode 3
  cpr-ext-win-mode 8
  rx-voa fixed-ratio 1200
  filter-roll-off-factor 0.035
!
controller Optics0/1/0/5
  soak-time 10
!

```

Chromatic Dispersion Threshold

You can configure the minimum and maximum acceptable chromatic dispersion for the trunk optics controllers. The CD alarm is raised if the chromatic dispersion goes below the minimum or exceeds the maximum value.

The following is a sample of configuring the minimum and maximum chromatic dispersion threshold:

To configure the maximum and minimum acceptable CD, use the following command:

configure

controller optics *R/S/I/P*

cd-high-threshold *cd-high*

cd-low-threshold *cd-low*

commit

The following sample configures the maximum and minimum acceptable CD on the controller optics:

```

RP/0/RP0/CPU0:ios#configure
RP/0/RP0/CPU0:ios(config)#controller optics 0/0/0/7
RP/0/RP0/CPU0:ios(config-Optics)#cd-high-threshold 2400
RP/0/RP0/CPU0:ios(config-Optics)#cd-low-threshold -2400
RP/0/RP0/CPU0:ios(config-Optics)#commit

```

The following sample shows the maximum and minimum acceptable CD configured on the controller optics:

```

RP/0/RP0/CPU0:ios#show controllers optics 0/0/0/7
Fri Nov 12 10:58:50.595 UTC

Controller State: Up

```

Transport Admin State: In Service

Laser State: On

LED State: Yellow

Optics Status

Optics Type: CIM8 DWDM
 DWDM carrier Info: C BAND, MSA ITU Channel=61, Frequency=193.10THz,
 Wavelength=1552.524nm

Alarm Status:

 Detected Alarms:
 HIGH-RX-PWR LOW-TX-PWR
 HIGH-DGD

LOS/LOL/Fault Status:

Alarm Statistics:

 HIGH-RX-PWR = 1 LOW-RX-PWR = 0
 HIGH-TX-PWR = 0 LOW-TX-PWR = 1
 HIGH-LBC = 0 HIGH-DGD = 6
 OOR-CD = 0 OSNR = 0
 WVLT-OOL = 0 MEA = 0
 IMPROPER-REM = 1
 TX-POWER-PROV-MISMATCH = 0
 Laser Bias Current = 0.0 %
 Actual TX Power = 0.97 dBm
 RX Power = -0.53 dBm
 RX Signal Power = -1.20 dBm
 Frequency Offset = 63 MHz

Performance Monitoring: Enable

THRESHOLD VALUES

Parameter	High Alarm	Low Alarm	High Warning	Low Warning
-----	-----	-----	-----	-----
Rx Power Threshold(dBm)	-2.0	-3.0	0.0	0.0
Tx Power Threshold(dBm)	4.0	2.0	0.0	0.0
LBC Threshold(mA)	N/A	N/A	0.00	0.00

LBC High Threshold = 55 %
 Configured Tx Power = 1.00 dBm
Configured CD High Threshold = 2400 ps/nm
Configured CD lower Threshold = -2400 ps/nm
 Configured OSNR lower Threshold = 0.40 dB
 Configured DGD Higher Threshold = 0.30 ps
 Baud Rate = 63.1394679230 GBd
 Bits per Symbol = 3.0000000000 bits/symbol
 Modulation Type: 8QAM
 Chromatic Dispersion 0 ps/nm
 Configured CD-MIN -48000 ps/nm CD-MAX 48000 ps/nm
 Polarization Mode Dispersion = 0.0 ps
 Second Order Polarization Mode Dispersion = 29.00 ps^2
 Optical Signal to Noise Ratio = 36.10 dB
 SNR = 17.50 dB
 Polarization Dependent Loss = 0.50 dB

```
Polarization Change Rate = 0.00 rad/s
Differential Group Delay = 1.00 ps
```

Transceiver Vendor Details

```
Form Factor           : CIM8
Name                  : CISCO-ACACIA
Part Number           : 10-3500-01
Rev Number            : 01
Serial Number         : ACA24480037
PID                   : CIM8-C-K9
VID                   : VES1
Date Code (yy/mm/dd) : 23/11/10
Fiber Connector Type: LC
Otn Application Code: Not Set
Sonet Application Code: Not Set
Ethernet Compliance Code: Not set
```

```
Transceiver Temperature : 46 Celsius
```

```
AINS Soak             : None
AINS Timer             : 0h, 0m
AINS remaining time   : 0 seconds
```

Transmit Power

To configure transmit power on the trunk (CIM8 and PICO) optics within the -190 to $+50$ range (in units of 0.1dBm), use the following commands:

```
RP/0/RP0/CPU0:ios#configure
Mon Aug 19 19:31:42.115 UTC
RP/0/RP0/CPU0:ios(config)#controller optics 0/1/0/7
RP/0/RP0/CPU0:ios(config-Optics)#transmit-power -1.50
RP/0/RP0/CPU0:ios(config-Optics)#commit
Mon Aug 19 19:35:24.697 UTC
RP/0/RP0/CPU0:ios(config-Optics)#exit
RP/0/RP0/CPU0:ios(config)#exit
```

The following is a sample in which transmit power of -1.50 dBm is configured on the CIM8 optics.

```
RP/0/RP0/CPU0:ios#show controllers optics 0/0/0/7
Controller State: Up
Transport Admin State: Automatic In Service
Laser State: On
LED State: Green
Optics Status
  Optics Type: CIM8 DWDM
  DWDM carrier Info: C BAND, MSA ITU Channel=61, Frequency=193.10THz,
  Wavelength=1552.524nm
  Alarm Status:
  -----
  Detected Alarms: None
  LOS/LOL/Fault Status:
  Alarm Statistics:
  HIGH-RX-PWR = 0           LOW-RX-PWR = 2
  HIGH-TX-PWR = 0           LOW-TX-PWR = 1
  HIGH-LBC = 0              HIGH-DGD = 0
  OOR-CD = 0                OSNR = 1
```

```

WVL-OOL = 0                MEA = 0
IMPROPER-REM = 0
TX-POWER-PROV-MISMATCH = 0
Laser Bias Current = 0.0 %
Actual TX Power = 1.98 dBm
RX Power = -0.68 dBm
RX Signal Power = -1.25 dBm
Frequency Offset = -41 MHz
Performance Monitoring: Enable
THRESHOLD VALUES
Parameter                    High Alarm  Low Alarm  High Warning  Low Warning
-----
Rx Power Threshold(dBm)      13.0       -17.0      0.0           0.0
Tx Power Threshold(dBm)      5.0        -13.0      0.0           0.0
LBC Threshold(mA)            N/A        N/A        0.00          0.00
LBC High Threshold = 90 %
Configured Tx Power = 2.00 dBm
Configured CD High Threshold = 180000 ps/nm
Configured CD lower Threshold = -180000 ps/nm
Configured OSNR lower Threshold = 20.50 dB
Configured DGD Higher Threshold = 90.00 ps
Baud Rate = 137.9783940000 GBd
Bits per Symbol = 3.5200000000 bits/symbol
Modulation Type: PCS
Chromatic Dispersion -1 ps/nm
Configured CD-MIN -10000 ps/nm CD-MAX 48000 ps/nm
Polarization Mode Dispersion = 0.0 ps
Second Order Polarization Mode Dispersion = 13.00 ps^2
Optical Signal to Noise Ratio = 38.10 dB
SNR = 17.40 dB
Polarization Dependent Loss = 2.50 dB
Polarization Change Rate = 0.00 rad/s
Differential Group Delay = 1.00 ps
Filter Roll Off Factor : 0.100
Rx VOA Target Power : -2.0 dBm
NLEQ Compensation Mode : 0
Cross Polarization Gain Mode : 10
Proprietary Submarine Parameters
Type : 1      Value : 0
Type : 2      Value : 0
Type : 3      Value : 0
Type : 4      Value : 0
Type : 5      Value : 0
Type : 6      Value : 1000
Type : 7      Value : 0
Type : 8      Value : 0
Type : 9      Value : 0
Type : 10     Value : 0

```

Laser Bias Current High Threshold

You can configure the threshold of the laser bias current flowing on the physical pluggable port on the trunk optics controller. The range is 0 to 100%

To configure the laser bias current threshold, use the following command:

configure

controller optics R/S/I/P

lbc-high-threshold lbc-value

commit

The following sample configures the high laser bias threshold on the controller optics:

```
RP/0/RP0/CPU0:ios#configure
RP/0/RP0/CPU0:ios(config)#controller optics 0/0/0/7
RP/0/RP0/CPU0:ios(config-Optics)#lbc-high-threshold 55
RP/0/RP0/CPU0:ios(config-Optics)#commit
```

The following sample shows the high laser bias threshold configured on the controller optics:

```
RP/0/RP0/CPU0:ios#show controllers optics 0/0/0/7
Fri Nov 12 10:58:50.595 UTC

Controller State: Up

Transport Admin State: In Service

Laser State: On

LED State: Yellow

Optics Status

    Optics Type: CIM8 DWDM
    DWDM carrier Info: C BAND, MSA ITU Channel=61, Frequency=193.10THz,
    Wavelength=1552.524nm

    Alarm Status:
    -----
    Detected Alarms:
                HIGH-RX-PWR   LOW-TX-PWR
                HIGH-DGD

    LOS/LOL/Fault Status:

    Alarm Statistics:

    -----
    HIGH-RX-PWR = 1           LOW-RX-PWR = 0
    HIGH-TX-PWR = 0           LOW-TX-PWR = 1
    HIGH-LBC = 0              HIGH-DGD = 6
    OOR-CD = 0                OSNR = 0
    WVL-OOL = 0               MEA = 0
    IMPROPER-REM = 1
    TX-POWER-PROV-MISMATCH = 0
    Laser Bias Current = 0.0 %
    Actual TX Power = 0.97 dBm
    RX Power = -0.53 dBm
    RX Signal Power = -1.20 dBm
    Frequency Offset = 63 MHz

    Performance Monitoring: Enable

    THRESHOLD VALUES
    -----

    Parameter                High Alarm  Low Alarm  High Warning  Low Warning
    -----
    Rx Power Threshold(dBm)   -2.0       -3.0       0.0           0.0
    Tx Power Threshold(dBm)   4.0        2.0        0.0           0.0
    LBC Threshold(mA)         N/A        N/A        0.00          0.00

LBC High Threshold = 55 %
    Configured Tx Power = 1.00 dBm
```



```

Configured CD High Threshold = 2400 ps/nm
Configured CD lower Threshold = -2400 ps/nm
Configured OSNR lower Threshold = 0.40 dB
Configured DGD Higher Threshold = 0.30 ps
Baud Rate = 63.1394679230 GBd
Bits per Symbol = 3.0000000000 bits/symbol
Modulation Type: 8QAM
Chromatic Dispersion 0 ps/nm
Configured CD-MIN -48000 ps/nm CD-MAX 48000 ps/nm
Polarization Mode Dispersion = 0.0 ps
Second Order Polarization Mode Dispersion = 29.00 ps^2
Optical Signal to Noise Ratio = 36.10 dB
SNR = 17.50 dB
Polarization Dependent Loss = 0.50 dB
Polarization Change Rate = 0.00 rad/s
Differential Group Delay = 1.00 ps

```

Transceiver Vendor Details

```

Form Factor           : CIM8
Name                  : CISCO-ACACIA
Part Number           : 10-3500-01
Rev Number            : 01
Serial Number         : ACA24480037
PID                   : CIM8-C-K9
VID                   : VES1
Date Code (yy/mm/dd) : 23/11/10
Fiber Connector Type : LC
Otn Application Code  : Not Set
Sonet Application Code: Not Set
Ethernet Compliance Code: Not set

```

Transceiver Temperature : 46 Celsius

```

AINS Soak             : None
AINS Timer             : 0h, 0m
AINS remaining time   : 0 seconds

```

Differential Group Delay Threshold

You can configure the threshold value for the maximum acceptable differential group delay (DGD) on the trunk optics controllers. The DGD alarm is raised if DGD exceeds this value.

The range is 0–18000 (in the units of 0.01 ps).

To configure the maximum acceptable DGD, use the following command:

```

configure
controller optics R/S/I/P
dgd-high-threshold dgd-value
commit

```

The following sample configures the minimum acceptable DGD on the controller optics:

```

RP/0/RP0/CPU0:ios#configure
RP/0/RP0/CPU0:ios(config)#controller optics 0/0/0/7

```

```
RP/0/RP0/CPU0:ios(config-Optics)#dgd-high-threshold 30
RP/0/RP0/CPU0:ios(config-Optics)#commit
```

The following sample shows the maximum acceptable DGD configured on the controller optics:

```
RP/0/RP0/CPU0:ios#show controllers optics 0/0/0/7
Fri Nov 12 10:58:50.595 UTC
```

Controller State: Up

Transport Admin State: In Service

Laser State: On

LED State: Yellow

Optics Status

```
Optics Type: CIM8 DWDM
DWDM carrier Info: C BAND, MSA ITU Channel=61, Frequency=193.10THz,
Wavelength=1552.524nm
```

Alarm Status:

Detected Alarms:

```
        HIGH-RX-PWR    LOW-TX-PWR
        HIGH-DGD
```

LOS/LOL/Fault Status:

Alarm Statistics:

```
HIGH-RX-PWR = 1          LOW-RX-PWR = 0
HIGH-TX-PWR = 0          LOW-TX-PWR = 1
HIGH-LBC = 0             HIGH-DGD = 6
OOR-CD = 0               OSNR = 0
WVL-OOL = 0              MEA = 0
IMPROPER-REM = 1
TX-POWER-PROV-MISMATCH = 0
Laser Bias Current = 0.0 %
Actual TX Power = 0.97 dBm
RX Power = -0.53 dBm
RX Signal Power = -1.20 dBm
Frequency Offset = 63 MHz
```

Performance Monitoring: Enable

THRESHOLD VALUES

Parameter	High Alarm	Low Alarm	High Warning	Low Warning
Rx Power Threshold(dBm)	-2.0	-3.0	0.0	0.0
Tx Power Threshold(dBm)	4.0	2.0	0.0	0.0
LBC Threshold(mA)	N/A	N/A	0.00	0.00

LBC High Threshold = 55 %

Configured Tx Power = 1.00 dBm

Configured CD High Threshold = 2400 ps/nm

Configured CD lower Threshold = -2400 ps/nm

Configured OSNR lower Threshold = 0.40 dB

Configured DGD Higher Threshold = 0.30 ps

Baud Rate = 63.1394679230 GBd

Bits per Symbol = 3.0000000000 bits/symbol

```

Modulation Type: 8QAM
Chromatic Dispersion 0 ps/nm
Configured CD-MIN -48000 ps/nm CD-MAX 48000 ps/nm
Polarization Mode Dispersion = 0.0 ps
Second Order Polarization Mode Dispersion = 29.00 ps^2
Optical Signal to Noise Ratio = 36.10 dB
SNR = 17.50 dB
Polarization Dependent Loss = 0.50 dB
Polarization Change Rate = 0.00 rad/s
Differential Group Delay = 1.00 ps

```

Transceiver Vendor Details

```

Form Factor           : CIM8
Name                  : CISCO-ACACIA
Part Number           : 10-3500-01
Rev Number            : 01
Serial Number         : ACA24480037
PID                   : CIM8-C-K9
VID                   : VES1
Date Code (yy/mm/dd) : 23/11/10
Fiber Connector Type : LC
Otn Application Code  : Not Set
Sonet Application Code: Not Set
Ethernet Compliance Code: Not set

```

Transceiver Temperature : 46 Celsius

```

AINS Soak             : None
AINS Timer             : 0h, 0m
AINS remaining time   : 0 seconds

```

Optical Signal to Noise Ratio

You can configure the minimum acceptable Optical Signal to Noise ratio (OSNR) value on the 1.2T, 2.4TX, and 2.4T cards. The OSNR alarm is raised if OSNR goes below this value.

The range is 0–4000 (in units of 0.01db).

To configure the minimum acceptable OSNR, use the following command:

```

configure
controller optics R/S/I/P
osnr-low-threshold osnr-value
commit

```

The following sample configures the minimum acceptable OSNR on the controller optics:

```

RP/0/RP0/CPU0:ios#configure
RP/0/RP0/CPU0:ios(config)#controller optics 0/0/0/7
RP/0/RP0/CPU0:ios(config-Optics)#osnr-low-threshold 40
RP/0/RP0/CPU0:ios(config-Optics)#commit

```

The following sample shows the minimum acceptable OSNR configured on the controller optics:

```

RP/0/RP0/CPU0:ios#show controllers optics 0/0/0/7
Fri Nov 12 10:58:50.595 UTC

```

Controller State: Up

Transport Admin State: In Service

Laser State: On

LED State: Yellow

Optics Status

Optics Type: CIM8 DWDM
 DWDM carrier Info: C BAND, MSA ITU Channel=61, Frequency=193.10THz,
 Wavelength=1552.524nm

Alarm Status:

Detected Alarms:

HIGH-RX-PWR LOW-TX-PWR
 HIGH-DGD

LOS/LOL/Fault Status:

Alarm Statistics:

HIGH-RX-PWR = 1 LOW-RX-PWR = 0
 HIGH-TX-PWR = 0 LOW-TX-PWR = 1
 HIGH-LBC = 0 HIGH-DGD = 6
 OOR-CD = 0 OSNR = 0
 WV-L-OOL = 0 MEA = 0
 IMPROPER-REM = 1
 TX-POWER-PROV-MISMATCH = 0
 Laser Bias Current = 0.0 %
 Actual TX Power = 0.97 dBm
 RX Power = -0.53 dBm
 RX Signal Power = -1.20 dBm
 Frequency Offset = 63 MHz

Performance Monitoring: Enable

THRESHOLD VALUES

Parameter	High Alarm	Low Alarm	High Warning	Low Warning
Rx Power Threshold(dBm)	-2.0	-3.0	0.0	0.0
Tx Power Threshold(dBm)	4.0	2.0	0.0	0.0
LBC Threshold(mA)	N/A	N/A	0.00	0.00

LBC High Threshold = 55 %

Configured Tx Power = 1.00 dBm

Configured CD High Threshold = 2400 ps/nm

Configured CD lower Threshold = -2400 ps/nm

Configured OSNR lower Threshold = 0.40 dB

Configured DGD Higher Threshold = 0.30 ps

Baud Rate = 63.1394679230 GBd

Bits per Symbol = 3.0000000000 bits/symbol

Modulation Type: 8QAM

Chromatic Dispersion 0 ps/nm

Configured CD-MIN -48000 ps/nm CD-MAX 48000 ps/nm

Polarization Mode Dispersion = 0.0 ps

Second Order Polarization Mode Dispersion = 29.00 ps^2

Optical Signal to Noise Ratio = 36.10 dB

SNR = 17.50 dB

```
Polarization Dependent Loss = 0.50 dB
Polarization Change Rate = 0.00 rad/s
Differential Group Delay = 1.00 ps
```

Transceiver Vendor Details

```
Form Factor           : CIM8
Name                  : CISCO-ACACIA
Part Number           : 10-3500-01
Rev Number            : 01
Serial Number         : ACA24480037
PID                   : CIM8-C-K9
VID                   : VES1
Date Code (yy/mm/dd) : 23/11/10
Fiber Connector Type : LC
Otn Application Code  : Not Set
Sonet Application Code: Not Set
Ethernet Compliance Code: Not set
```

Transceiver Temperature : 46 Celsius

```
AINS Soak             : None
AINS Timer             : 0h, 0m
AINS remaining time   : 0 seconds
```

Receive Power Threshold

You can configure the high and low threshold of the total optical signal power of the received signal on the 1.2T, 2.4TX, and 2.4T cards.

The range is -400 to 300 (in the units of 0.1 dBm).

To configure the high and low receive power threshold, use the following command:

configure

controller optics *R/S/I/P*

rx-high-threshold *rx-high*

rx-low-threshold *rx-low*

commit

The following sample configures the high receive power threshold on the controller optics:

```
RP/0/RP0/CPU0:ios#configure
RP/0/RP0/CPU0:ios(config)#controller optics 0/0/0/7
RP/0/RP0/CPU0:ios(config-Optics)#rx-high-threshold -20
RP/0/RP0/CPU0:ios(config-Optics)#rx-low-threshold -30
RP/0/RP0/CPU0:ios(config-Optics)#commit
```

The following sample shows the high receive power threshold configured on the controller optics:

```
RP/0/RP0/CPU0:ios#show controllers optics 0/0/0/7
Fri Nov 12 10:58:50.595 UTC
```

Controller State: Up

Transport Admin State: In Service

Laser State: On

LED State: Yellow

Optics Status

Optics Type: CIM8 DWDM
 DWDM carrier Info: C BAND, MSA ITU Channel=61, Frequency=193.10THz,
 Wavelength=1552.524nm

Alarm Status:

Detected Alarms:

HIGH-RX-PWR LOW-TX-PWR
 HIGH-DGD

LOS/LOL/Fault Status:

Alarm Statistics:

HIGH-RX-PWR = 1 LOW-RX-PWR = 0
 HIGH-TX-PWR = 0 LOW-TX-PWR = 1
 HIGH-LBC = 0 HIGH-DGD = 6
 OOR-CD = 0 OSNR = 0
 WVL-OOL = 0 MEA = 0
 IMPROPER-REM = 1
 TX-POWER-PROV-MISMATCH = 0
 Laser Bias Current = 0.0 %
 Actual TX Power = 0.97 dBm
 RX Power = -0.53 dBm
 RX Signal Power = -1.20 dBm
 Frequency Offset = 63 MHz

Performance Monitoring: Enable

THRESHOLD VALUES

Parameter	High Alarm	Low Alarm	High Warning	Low Warning
Rx Power Threshold(dBm)	-2.0	-3.0	0.0	0.0
Tx Power Threshold(dBm)	4.0	2.0	0.0	0.0
LBC Threshold(mA)	N/A	N/A	0.00	0.00

LBC High Threshold = 55 %
 Configured Tx Power = 1.00 dBm
 Configured CD High Threshold = 2400 ps/nm
 Configured CD lower Threshold = -2400 ps/nm
 Configured OSNR lower Threshold = 0.40 dB
 Configured DGD Higher Threshold = 0.30 ps
 Baud Rate = 63.1394679230 GBd
 Bits per Symbol = 3.0000000000 bits/symbol
 Modulation Type: 8QAM
 Chromatic Dispersion 0 ps/nm
 Configured CD-MIN -48000 ps/nm CD-MAX 48000 ps/nm
 Polarization Mode Dispersion = 0.0 ps
 Second Order Polarization Mode Dispersion = 29.00 ps^2
 Optical Signal to Noise Ratio = 36.10 dB
 SNR = 17.50 dB
 Polarization Dependent Loss = 0.50 dB
 Polarization Change Rate = 0.00 rad/s
 Differential Group Delay = 1.00 ps

Transceiver Vendor Details

```

Form Factor           : CIM8
Name                  : CISCO-ACACIA
Part Number           : 10-3500-01
Rev Number            : 01
Serial Number         : ACA24480037
PID                   : CIM8-C-K9
VID                   : VES1
Date Code (yy/mm/dd) : 23/11/10
Fiber Connector Type : LC
Otn Application Code  : Not Set
Sonet Application Code: Not Set
Ethernet Compliance Code: Not set

```

```
Transceiver Temperature : 46 Celsius
```

```

AINS Soak             : None
AINS Timer             : 0h, 0m
AINS remaining time   : 0 seconds

```

Transmit Power Threshold

You can configure the high and low threshold of the total optical signal power of the transmitted signal on the 1.2T, 2.4TX, and 2.4T cards.

The range is -400 to 300 (in the units of 0.1 dBm).

To configure the high and low transmit power threshold, use the following command:

configure

controller optics *R/S/I/P*

tx-high-threshold *tx-high*

tx-low-threshold *tx-low*

commit

The following sample configures the high transmit power threshold on the controller optics:

```

RP/0/RP0/CPU0:ios#configure
RP/0/RP0/CPU0:ios(config)#controller optics 0/0/0/7
RP/0/RP0/CPU0:ios(config-Optics)#tx-high-threshold 40
RP/0/RP0/CPU0:ios(config-Optics)#tx-low-threshold 20
RP/0/RP0/CPU0:ios(config-Optics)#commit

```

The following sample shows the high transmit power threshold configured on the controller optics:

```

RP/0/RP0/CPU0:ios#show controllers optics 0/0/0/7
Fri Nov 12 10:58:50.595 UTC

Controller State: Up

Transport Admin State: In Service

Laser State: On

LED State: Yellow

```

Optics Status

Optics Type: CIM8 DWDM
 DWDM carrier Info: C BAND, MSA ITU Channel=61, Frequency=193.10THz,
 Wavelength=1552.524nm

Alarm Status:

Detected Alarms:

HIGH-RX-PWR LOW-TX-PWR
 HIGH-DGD

LOS/LOL/Fault Status:

Alarm Statistics:

HIGH-RX-PWR = 1 LOW-RX-PWR = 0
 HIGH-TX-PWR = 0 LOW-TX-PWR = 1
 HIGH-LBC = 0 HIGH-DGD = 6
 OOR-CD = 0 OSNR = 0
 WV-L-OOL = 0 MEA = 0
 IMPROPER-REM = 1
 TX-POWER-PROV-MISMATCH = 0
 Laser Bias Current = 0.0 %
 Actual TX Power = 0.97 dBm
 RX Power = -0.53 dBm
 RX Signal Power = -1.20 dBm
 Frequency Offset = 63 MHz

Performance Monitoring: Enable

THRESHOLD VALUES

Parameter	High Alarm	Low Alarm	High Warning	Low Warning
Rx Power Threshold(dBm)	-2.0	-3.0	0.0	0.0
Tx Power Threshold(dBm)	4.0	2.0	0.0	0.0
LBC Threshold(mA)	N/A	N/A	0.00	0.00

LBC High Threshold = 55 %
 Configured Tx Power = 1.00 dBm
 Configured CD High Threshold = 2400 ps/nm
 Configured CD lower Threshold = -2400 ps/nm
 Configured OSNR lower Threshold = 0.40 dB
 Configured DGD Higher Threshold = 0.30 ps
 Baud Rate = 63.1394679230 GBd
 Bits per Symbol = 3.0000000000 bits/symbol
 Modulation Type: 8QAM
 Chromatic Dispersion 0 ps/nm
 Configured CD-MIN -48000 ps/nm CD-MAX 48000 ps/nm
 Polarization Mode Dispersion = 0.0 ps
 Second Order Polarization Mode Dispersion = 29.00 ps^2
 Optical Signal to Noise Ratio = 36.10 dB
 SNR = 17.50 dB
 Polarization Dependent Loss = 0.50 dB
 Polarization Change Rate = 0.00 rad/s
 Differential Group Delay = 1.00 ps

Transceiver Vendor Details

Form Factor : CIM8
 Name : CISCO-ACACIA

```

Part Number          : 10-3500-01
Rev Number           : 01
Serial Number        : ACA24480037
PID                  : CIM8-C-K9
VID                  : VES1
Date Code (yy/mm/dd) : 23/11/10
Fiber Connector Type: LC
Otn Application Code: Not Set
Sonet Application Code: Not Set
Ethernet Compliance Code: Not set

```

Transceiver Temperature : 46 Celsius

```

AINS Soak            : None
AINS Timer           : 0h, 0m
AINS remaining time  : 0 seconds

```

Frequency

You can configure the frequency on trunk ports of the 1.2T, 2.4TX, and 2.4T line cards.

The following table lists the frequency range with grid spacing supported on the line card:

Line Card	Frequency Range (THz)	Default Frequency (THz)	Grid Spacing
1.2T	191.25 to 196.1	193.1	50GHz and 100MHz
1.2TL 1	186.1 to 190.85	188.5	100MHz
2.4T	191.25 to 196.1	193.1	50GHz and 100MHz
2.4TX using C band trunk pluggables	191.25 to 196.1	193.1	50GHz and 100MHz
2.4TX using L band trunk pluggables	186.15 to 190.925	No default frequency	100MHz

¹ Only non-ITU channels are supported

To configure the wavelength, use the following commands:

configure

controller optics *Rack/Slot/Instance/Port*

dwdm-carrier {100MHz-grid frequency *frequency*} | {50GHz-grid [*frequency frequency*]}

commit

CCMD-16 Controllers

The NCS1K14-CCMD-16-C and NCS1K14-CCMD-16-L cards have two types of controllers. The controllers are OMS and OCH controllers. When the NCS1K14-CCMD-16-C and NCS1K14-CCMD-16-L cards become operational, both the OMS and OCH controllers are automatically created by default.

To view the OCH controllers, run the following command:

Command

```
RP/0/RP0/CPU0:ios#show controllers och ?
```

The following output shows the active OCH controllers in *Slot 0* from *port 1 to 16*.

Output Example

```
0/0/0/1          Och Interface Instance
0/0/0/10         Och Interface Instance
0/0/0/11         Och Interface Instance
0/0/0/12         Och Interface Instance
0/0/0/13         Och Interface Instance
0/0/0/14         Och Interface Instance
0/0/0/15         Och Interface Instance
0/0/0/16       Och Interface Instance
0/0/0/2          Och Interface Instance
0/0/0/3          Och Interface Instance
0/0/0/4          Och Interface Instance
0/0/0/5          Och Interface Instance
0/0/0/6          Och Interface Instance
0/0/0/7          Och Interface Instance
0/0/0/8          Och Interface Instance
0/0/0/9          Och Interface Instance
```

To view the OMS controllers, run the following command:

Command

```
RP/0/RP0/CPU0:ios#show controllers oms ?
```

The following output shows the active OMS controller in *Slot 0*.

Output Example

```
0/0/0/0          Oms Interface Instance
```

OCH Controller

When you bring up the nodes with NCS1K14-CCMD-16-C and NCS1K14-CCMD-16-L cards, the OCH controllers are automatically created by default. The OCH controllers for the NCS1K14-CCMD-16-C and NCS1K14-CCMD-16-L cards are:

Table 3: Supported Interfaces

Card	Port Type	OCH Ports	Interfaces
NCS1K14-CCMD-16-C	LC Ports	16	och R/S/I/1 to och R/S/I/16

Card	Port Type	OCH Ports	Interfaces
NCS1K14-CCMD-16-L	LC Ports	16	och R/S/I/1 to och R/S/I/16



Note R/S/I/P stands for Rack/Slot/Instance/Port.

To view the parameters of an OCH controller, use the following command:

Command Example

```
RP/0/RP0/CPU0:ios#show controllers och 0/1/0/1
```

The following output shows the parameters of the OCH controller.

Output Example

```
Thu Oct 12 09:26:38.555 UTC

Controller State: Up

Transport Admin State: In Service

LED State: Green

Alarm Status:
-----
Detected Alarms: None

Alarm Statistics:
-----
RX-LOS-P = 0
TX-POWER-FAIL-LOW = 0

Parameter Statistics:
-----
Tx Power = -2.30 dBm
Rx Power = -0.70 dBm
```

OMS Controller

When you bring up the nodes with NCS1K14-CCMD-16-C and NCS1K14-CCMD-16-L cards, the OMS controllers are automatically created by default. The OMS controllers for the NCS1K14-CCMD-16-C and NCS1K14-CCMD-16-L cards are:

Table 4: Supported Interfaces

Card	Port Type	OMS Ports	Interfaces
NCS1K14-CCMD-16-C	LC Ports	1	oms R/S/I/0
NCS1K14-CCMD-16-L	LC Ports	1	oms R/S/I/0



Note R/S/I/P stands for Rack/Slot/Instance/Port.

To view the parameters of an OMS controller, use the following command:

Command Example

```
RP/0/RP0/CPU0:ios#show controllers oms 0/1/0/0
```

The following output shows the parameters of an OMS controller.

Output Example

```
Thu Oct 12 09:23:35.297 UTC
```

```
Controller State: Up
```

```
Transport Admin State: In Service
```

```
LED State: Red
```

```
Alarm Status:
```

```
-----
```

```
Detected Alarms:
```

```
    HI-TX-BR-PWR
```

```
Alarm Statistics:
```

```
-----
```

```
RX-LOS-P = 3
```

```
TX-POWER-FAIL-LOW = 0
```

```
INGRESS-AMPLI-GAIN-LOW = 0
```

```
INGRESS-AMPLI-GAIN-HIGH = 0
```

```
EGRESS-AUTO-LASER-SHUT = 0
```

```
EGRESS-AMPLI-GAIN-LOW = 0
```

```
EGRESS-AMPLI-GAIN-HIGH = 0
```

```
HI-TX-BR-PWR = 2
```

```
Parameter Statistics:
```

```
-----
```

```
Tx Power = -3.40 dBm
```

```
Rx Power = -2.30 dBm
```

```
Rx Voa Attenuation = 5.0 dB
```

```
Tx Voa Attenuation = 5.0 dB
```

```
Ingress Ampli Mode = Gain
```

```
Ingress Ampli Gain = 5.0 dB
```

```
Ingress Ampli Tilt = 0.0 dB
```

```
Ingress Ampli OSRI = OFF
```

```
Egress Ampli Mode = Gain
```

```
Egress Ampli Gain = 2.0 dB
```

```
Egress Ampli Tilt = 0.0 dB
```

```
Egress Ampli Gain Range = Normal
```

```
Egress Ampli OSRI = OFF
```

```
Egress Ampli BR Power = -12.90 dBm
```

```
Egress Ampli BR Ratio = -9.39 dB
```

```
Configured Parameters:
```

```
-----
```

```
Rx Voa Attenuation = 5.0 dB
```

```
Tx Voa Attenuation = 5.0 dB
```

```
Ingress Ampli Mode = Gain
```

```
Ingress Ampli Gain = 5.0 dB
```

```

Ingress Ampli Power = -9.0 dBm
Ingress Ampli OSRI = OFF
Egress Ampli Mode = Gain
Egress Ampli Gain = 2.0 dB
Egress Ampli Power = 0.0 dBm
Egress Ampli Gain Range = Normal
Egress Ampli OSRI = OFF
BR High Threshold = -17.0 dBm

```

Configure Controller Parameters for NCS1K14-CCMD-16-C and NCS1K14-CCMD-16-L Cards

Table 5: Feature History

Feature Name	Release Information	Feature Description
Supported Functionalities of CCMD-16-C and CCMD-16-L Line Cards	Cisco IOS XR Release 7.11.1	Supported Functionalities of CCMD-16-C and CCMD-16-L Line Cards: The software supports Variable Optical Attenuator (VoA), power monitoring and reporting of parameters to the controllers at the OCH and OMS level. It helps in configuring the amplifier parameters for optimizing signal transmissions. The software also supports in-band and out-of-band tone detection and monitoring and reporting of alarms.

This chapter describes the controller configuration using EDFA, VoA, optical safety, and photodiode parameters which are supported on NCS1K14-CCMD-16-C and NCS1K14-CCMD-16-L line cards.

Table 6: Basic Controller Configuration Parameters

Parameter	CLI	Description
EDFA-ADD Control Mode	controller Oms R/S/I/P egress-ampli-mode power-control	Here the default mode is gain-control. Use this command to change the mode to power-control mode. You can delete this configuration to revert to gain-control mode.
EDFA-ADD Power	controller Oms R/S/I/P egress-ampli-power <val in 0.1 dBm>	This is the target output power configuration for the EDFA located on COM-Tx. If the output power is not configured, then a default value is used by the system. You can find the applied target output power by using the show controller oms output.

EDFA-ADD Gain Range	<code>controller Oms R/S/I/P egress-ampli-gain-range <normal extended></code>	
------------------------	-----------------------------------------------------------------------------------------------	--

If you change the gain range from Normal to Extended or the opposite way, without updating the proper gain value for the new gain range, then the following may happen:

- The EDFA switches to the preconfigured or default value of the gain causing a mismatch between the operational and configured gain.
- The gain configuration is lost during the reload of software or line card, as the configured gain mismatches with the latest gain-range. This may result in traffic interruption during these reload operations.

Hence, we recommend that you explicitly configure the gain range mode as normal or extended, and the corresponding gain values for each mode to get the expected results.

The following are a few example scenarios that may not work as expected:

- Scenario 1:

Current running config:

```
controller Oms R/S/I/P
  egress-ampli-gain-range extended
  egress-ampli-gain <gain value in
  extended mode>
```

New applied config:

```
controller Oms R/S/I/P
  no egress-ampli-gain-range extended
  commit
```

- Scenario 2:

Current running config:

```
controller Oms R/S/I/P
  egress-ampli-gain-range extended
  egress-ampli-gain <gain value in
  extended mode>
```

New applied config:

```
controller Oms R/S/I/P
  egress-ampli-gain-range Normal
  commit
```

- Scenario 3:

Current running config:

```
controller Oms R/S/I/P
  egress-ampli-gain <gain value in normal
  mode>
```

		<p>New applied config:</p> <pre>controller Oms R/S/I/P egress-ampli-gain-range extended commit</pre> <p>The following is another example scenario that involves commit-replace command where you replace the existing gain configuration that does not have explicitly configured gain-range, with new gain-range and gain value.</p> <p>Scenario 4:</p> <p>Current running config:</p> <pre>controller Oms R/S/I/P egress-ampli-gain <gain value in normal mode></pre> <p>New applied config:</p> <pre>..... controller Oms R/S/I/P egress-ampli-gain-range extended egress-ampli-gain <gain value in extended mode> commit replace</pre>
EDFA-ADD Gain	<pre>controller Oms R/S/I/P egress-ampli-gain <val in 0.1 dB></pre>	<p>This is used for configuring gain for the EDFA located on the COM-Tx port. If the gain is not configured, then a default value is used by the system. The show controller oms output can be used for finding the applied gain.</p>
EDFA-DROP Control Mode	<pre>controller Oms R/S/I/P ingress-ampli-mode power-control</pre>	<p>The default mode is gain-control.</p> <p>Use this command to change the mode to power-control mode.</p> <p>You can delete this configuration to revert to gain-control mode.</p>
EDFA-DROP Power	<pre>controller Oms R/S/I/P ingress-ampli-power <vale in 0.1 dBm></pre>	<p>This is the target output power configuration for the EDFA located on COM-Rx. If the output power is not configured, then a default value is used by the system. You can find the applied target output power by using the show controller oms output.</p>
EDFA-DROP Gain	<pre>controller Oms R/S/I/P ingress-ampli-gain <val in 0.1 dB></pre>	<p>This is used for configuring gain for the EDFA located on the COM-Rx port. If the gain is not configured, then a default value is used by the system. The show controller oms output can be used for finding the applied gain.</p>

VoA Attenuation	<pre>controller Oms R/S/I/P tx-voa-attenuation <val in 0.1 dB> rx-voa-attenuation <val in 01. dB></pre>	<p>This is used to configure VoA attenuation for COM-Tx and COM-Rx ports. The system picks a default value if the gain is not configured. The show controller oms output can be used for finding the applied attenuation.</p>
Shutdown (COM Port)	<pre>controller Oms R/S/I/P shutdown</pre>	<p>COM-Tx and Rx ports are put in Out of Service (OOS) when this command is executed. This turns off the EDFA devices on both COM-Tx and COM-Rx ports and the respective alarms are masked.</p> <p>Here the default value is 'unshut'.</p>
Shutdown (Ch Ports)	<pre>controller Och R/S/I/P shutdown</pre>	<p>The channel port will be marked as out-of-service.</p>

Configure Operational Parameters

The different operational parameters supported are given below.

Table 7: Operational Parameters

Parameter	CLI	Description
Photo Diodes (COM Port)	<p>OMS Controller</p> <pre>Tx Power and Rx Power</pre>	<p>Rx Power = Inband power + OOB Tx Power = Inband power + OOB</p> <p>It reports the power transmitted and received on the OMS port. The OOB power received on COM-Rx is looped back to COM-Tx with some loss due to the insertion-loss on the loop back path.</p>
Photo Diodes (CH Ports)	<p>OCH Controller</p> <pre>Tx Power and Rx Power</pre>	<p>It reports the power transmitted and received on the channel ports.</p>
Amplifier Parameters	<p>OMS Controller</p> <pre>Ingress Ampli Mode Ingress Ampli Gain Ingress Ampli Tilt Ingress Ampli OSRI Egress Ampli Mode Egress Ampli Gain Egress Ampli Tilt Egress Ampli Gain Range Egress Ampli OSRI Egress Ampli BR Power Egress Ampli BR Ratio</pre>	<p>Egress and ingress amplifier parameters.</p>

VoA Parameters	OMS Controller Tx VoA Attenuation and Rx VoA Attenuation	VoA attenuation parameters.
----------------	--------------------------------------------------------------------	-----------------------------

Configure Optical Safety Parameters

Use the following parameters for configuring optical safety.

Table 8: Optical Safety Parameters

Parameter	CLI	Description
OSRI	controller oms R/S/I/P egress-ampli-osri ingress-ampli-osri	Use this configuration to enable or Disable Optical Safety Remote Interlock (OSRI) on the amplifiers located on COM-Tx and COM-Rx ports. The default value is 'Off'. The show controller oms output can be used for finding the OSRI configuration and status.