



Connecting and Routing the Cables

This chapter describes how to connect and route the cables for NCS 2015.

The sections are:

- [Cable Routing and Management, on page 1](#)
- [NTP-L55 Routing and Locking Cable and Fiber Modules, on page 2](#)
- [NTP-L56 Attaching Wires to Alarm, Timing, LAN, and Craft Pin Connections, on page 3](#)

Cable Routing and Management

The NCS 2015 shelf has interchangeable fiber and cable modules. Because the NCS 2015 shelf is designed to be compliant with ETSI 600x300 standards, all wiring and cable connections are available on the front side.

Default Module

The NCS 2015 chassis is shipped with the fiber module installed. If you need to use CAT5 cables instead of optical fibers, replace the fiber module with the cable module.

Fiber Module

The fiber module can hold 160 fibers per exit point. The fiber diameter is a maximum of 1.8 mm. You need to determine your fiber size according to the number of cards and ports installed on each side of the shelf.

Cable and Fiber Routing

Cable and fiber routing accommodates all the high-density cards for line card connections in NCS 2015. The exit of the fibers and cables is split into two channels. The line card from slot 1 to 8 exits from the lower left side, and the line card from 9 to 17 exit from the lower right side. (See the figure below)

Figure 1: Cable and Fiber Routing in NCS 2015 DC Shelf

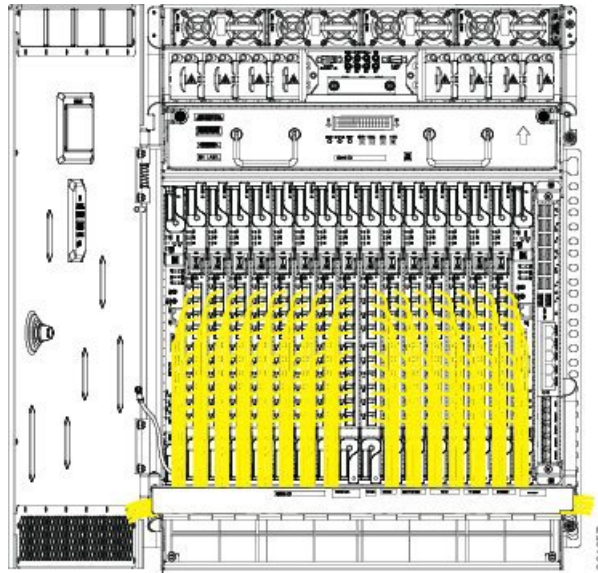

NTP-L55 Routing and Locking Cable and Fiber Modules

Purpose	This procedure routes and locks the cables on the NCS 2015 system.
Tools/Equipment	#1 Phillips cross-head PH screwdriver
Prerequisite Procedures	None
Required/As Needed	As needed
Onsite/Remote	Onsite
Security Level	None

Procedure

- Step 1** Route the ECU cables on the ECU handle and fix the cables using tie-wrap. The following figure shows an example of ECU cable routing. This allows you to close the front door.

Figure 2: ECU module Cable Routing in NCS 2015 DC Shelf

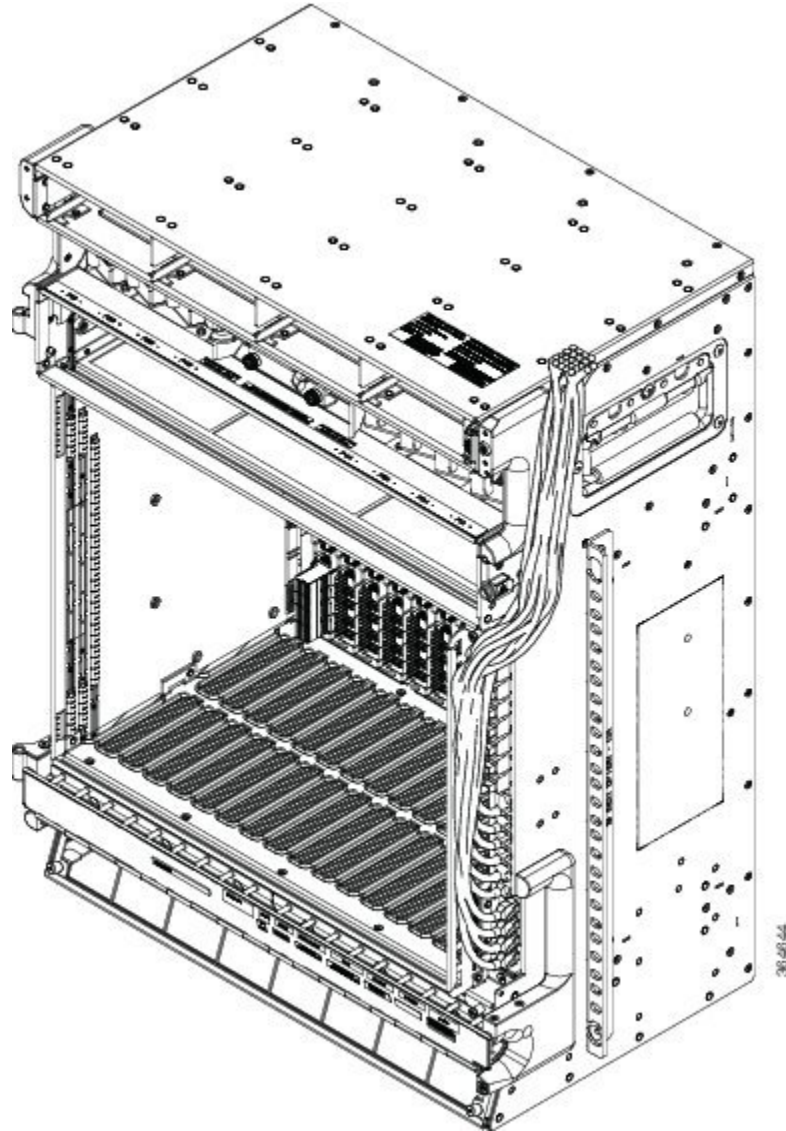

- Step 2** Route the optical cables from the line cards through the cable module as shown in the figure above.
Stop. You have completed this procedure.

NTP-L56 Attaching Wires to Alarm, Timing, LAN, and Craft Pin Connections

Purpose	Use this procedure to attach alarm, timing, LAN, and craft wires in the NCS 2015 shelf.
----------------	---

Tools/Equipment	Twisted #22 or #24 AWG (0.51 mm ² or 0.64 mm ²) shielded wires for LAN or craft 75-ohm coaxial cable with DIN-1.0/2.3 miniature coaxial connector, Alarm 26 pins SCSI cable.
Prerequisite Procedures	None
Required/As Needed	As needed
Onsite/Remote	Onsite
Security Level	None



Caution Always use the supplied ESD wristband when working with a powered NCS 2006. For detailed instructions on how to wear the ESD wristband, see the [Electrostatic Discharge and Grounding Guide for Cisco NCS 2000 Series](#).

Procedure

- Step 1** Complete [DLP-L76 Installing Alarm Wires in NCS 2015, on page 4](#) if you are provisioning external alarms.
- Step 2** Complete [DLP-L77 Installing Timing Wires on NCS 2015, on page 5](#) if you are provisioning external timing.
- Step 3** Complete [DLP-L78 Installing LAN Wires in NCS 2015, on page 9](#) to create an external LAN connection.

Stop. You have completed this procedure.

DLP-L76 Installing Alarm Wires in NCS 2015

Purpose	This task installs alarm cables on the power input panel of the NCS 2015 shelf to provision external (environmental) alarms and controls.
Tools/Equipment	Alarm SCSI 26-pin cable Wire-wrap tool for BITS Screw for the alarm cable
Prerequisite Procedures	None
Required/As Needed	As needed
Onsite/Remote	Onsite
Security Level	None

Procedure

Step 1 Connect one end of the SCSI cable to the input alarms or input/output alarms, and the other end to the alarm source (See the figure below).

Note These alarms are generic signals that the operator assigns to a definite wire (color) and name through the Craft Terminal.

Step 2 Tighten the screws of the SCSI connector to a torque value of 4 in-lb (0.45 N-m) using #2 Philips Dynamometric screwdriver.

Step 3 Bend the cable at an angle of 90° to exit from the left side or the right side (see the figures below).

Step 4 Return to your originating procedure (NTP).

Figure 3: Installing the Alarm Cable—Left and Right Exit

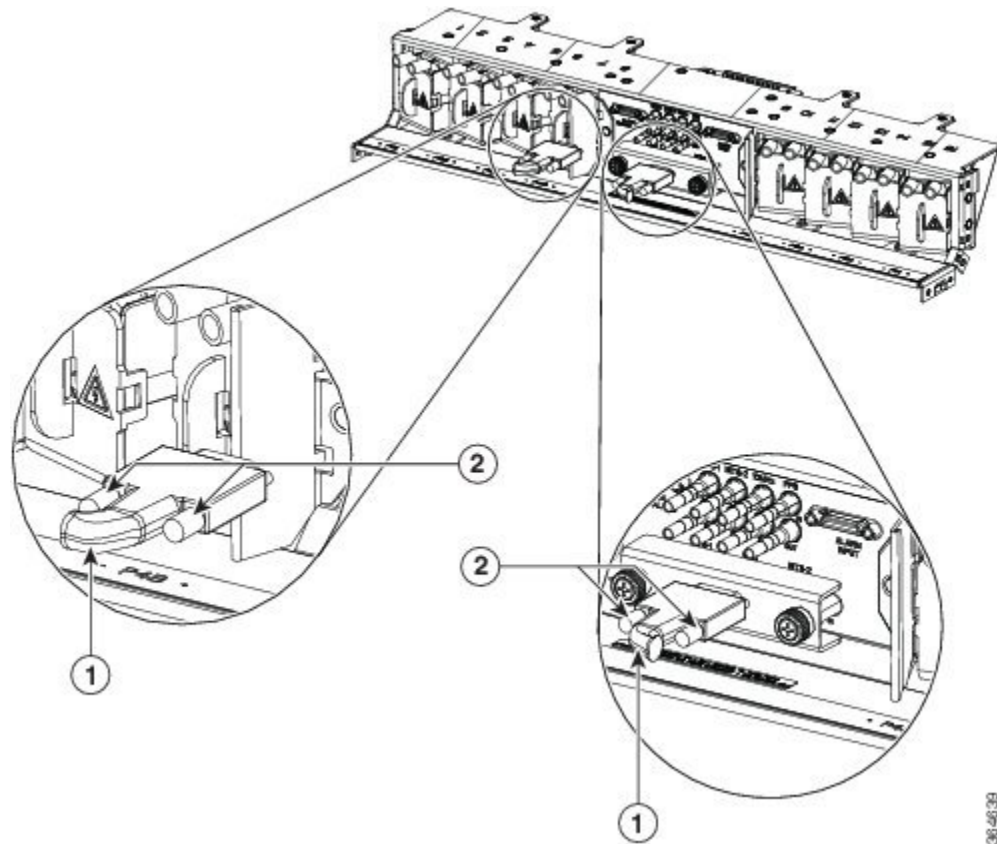

1	Alarm cable	2	Screws
---	-------------	---	--------

DLP-L77 Installing Timing Wires on NCS 2015

Purpose	This task installs the timing cables on the power input panel.
----------------	--

Tools/Equipment	Wire-wrap tool . <ul style="list-style-type: none"> • ANSI - 100-ohm shielded building integrated timing supply (BITS) clock cable pair #22 or #24 AWG (0.51 mm² or 0.64 mm²), twisted-pair T1-type • ETSI - 75-ohm coaxial cable with a DIN-1.0/2.3 miniature coaxial connector.
Prerequisite Procedures	None
Required/As Needed	As needed
Onsite/Remote	Onsite
Security Level	None

Procedure

Step 1 Locate the timing connectors on the power input panel (BITS-1 or BITS-2 In/Out). See the figure below.

Figure 4: Timing Connectors on the Power Input Panel

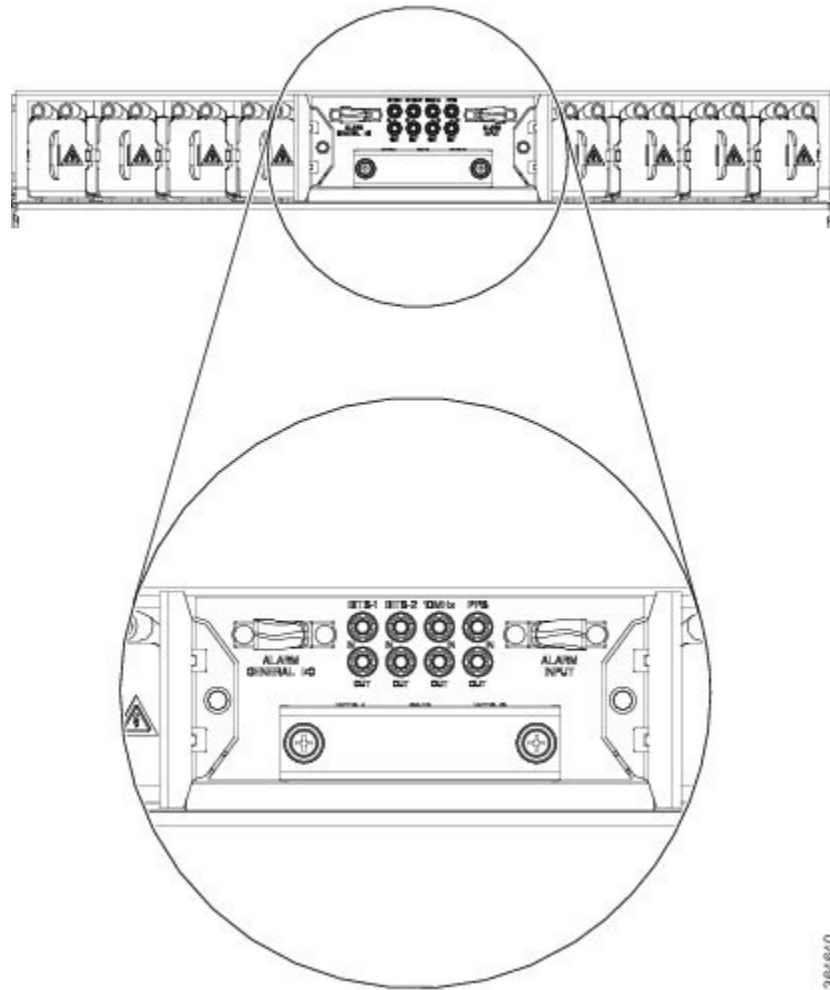

364640

Step 2 Loosen the screws on the protective cover as shown in the figure below.

Figure 5: Wire-wrap Cabling

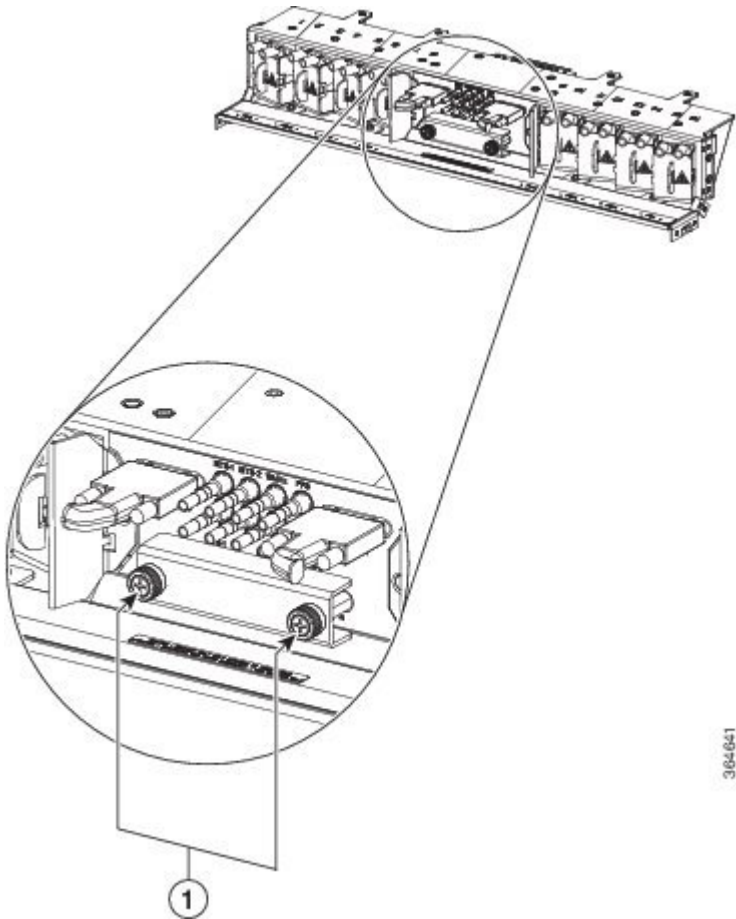

1	Screws
---	--------

Step 3 Connect one end of the wire-wrap clock cable to the corresponding wire-wrap connector on the power input panel and the other end to the external source of the timing. Change the timing input to high-impedance (lesser or greater than 3 ohms) using a jumper on the power input panel. To change the top timing input, remove the P1 jumper of the BITS-1, and to change the bottom timing input, remove the P2 Jumper of the BITS-2.

Note Route the wire-wrap connections as shown in the figure below

Figure 6: Wire-wrap Cabling

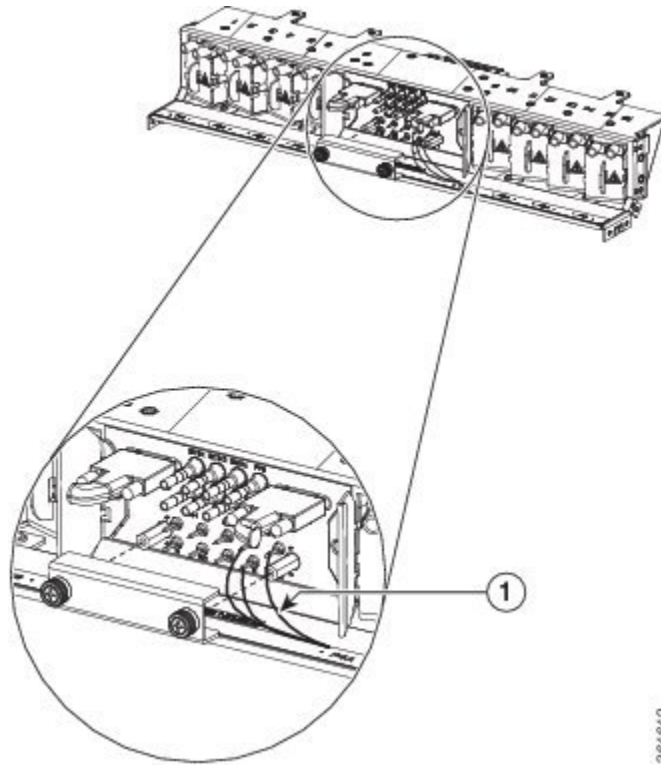

1	Wire wrap cables
---	------------------

- Step 4** Repeat for each cable. Refer to ITU-T G.813 for rules about provisioning timing references.
- Step 5** Secure the wire wrap cables on either side with a tie-wrap.
- Step 6** Return to your originating procedure (NTP).

DLP-L78 Installing LAN Wires in NCS 2015

Purpose	This task installs LAN wires on the ECU module of the NCS 2015.
Tools/Equipment	Standard CAT-5 Ethernet cable (straight-through for data terminating equipment [DTE] or cross-over for data circuit-terminating equipment [DCE]) or RJ-45 connector Crimping tool for RJ-45 connector 0.51 mm ² or 0.64 mm ² (#22 or #24 AWG) wire, preferably CAT-5
Prerequisite Procedures	None
Required/As Needed	As needed
Onsite/Remote	Onsite
Security Level	None

We recommend the use of RJ-45 port (craft terminal port or the EMS port) on the ECU module to establish LAN connectivity. The advantages of using the RJ-45 ports on the ECU module include:

- CAT-5 Ethernet cable connections can be managed better by routing the cable through the ECU module cable exit area.
- If the TNCS card fails, the LAN connection is not lost during the TNCS card switch over.

If the ECU module is absent, you can connect a CAT-5 Ethernet cable to the LAN port on the TNCS card to create an external LAN connection.



Note You can use the same procedure to connect Multishelf Management ports of several chassis in MSM configurations.



Note To avoid duplex mismatch between CT/EMS and external LAN switch ports, auto negotiation must be enabled on the external LAN switch port.

Procedure

- Step 1** Using 0.51 mm² or 0.64 mm² (#22 or #24 AWG) wire or a standard CAT-5 Ethernet cable, connect the wires to the RJ-45 connector.
- Step 2** Return to your originating procedure (NTP).
-