



Cisco ONS 15454 Reference Manual

Product and Documentation Release 7.0.1
August 2012

Americas Headquarters

Cisco Systems, Inc.
170 West Tasman Drive
San Jose, CA 95134-1706
USA
<http://www.cisco.com>
Tel: 408 526-4000
800 553-NETS (6387)
Fax: 408 527-0883

Text Part Number: OL-9217-01

THE SPECIFICATIONS AND INFORMATION REGARDING THE PRODUCTS IN THIS MANUAL ARE SUBJECT TO CHANGE WITHOUT NOTICE. ALL STATEMENTS, INFORMATION, AND RECOMMENDATIONS IN THIS MANUAL ARE BELIEVED TO BE ACCURATE BUT ARE PRESENTED WITHOUT WARRANTY OF ANY KIND, EXPRESS OR IMPLIED. USERS MUST TAKE FULL RESPONSIBILITY FOR THEIR APPLICATION OF ANY PRODUCTS.

THE SOFTWARE LICENSE AND LIMITED WARRANTY FOR THE ACCOMPANYING PRODUCT ARE SET FORTH IN THE INFORMATION PACKET THAT SHIPPED WITH THE PRODUCT AND ARE INCORPORATED HEREIN BY THIS REFERENCE. IF YOU ARE UNABLE TO LOCATE THE SOFTWARE LICENSE OR LIMITED WARRANTY, CONTACT YOUR CISCO REPRESENTATIVE FOR A COPY.

The following information is for FCC compliance of Class A devices: This equipment has been tested and found to comply with the limits for a Class A digital device, pursuant to part 15 of the FCC rules. These limits are designed to provide reasonable protection against harmful interference when the equipment is operated in a commercial environment. This equipment generates, uses, and can radiate radio-frequency energy and, if not installed and used in accordance with the instruction manual, may cause harmful interference to radio communications. Operation of this equipment in a residential area is likely to cause harmful interference, in which case users will be required to correct the interference at their own expense.

The following information is for FCC compliance of Class B devices: The equipment described in this manual generates and may radiate radio-frequency energy. If it is not installed in accordance with Cisco's installation instructions, it may cause interference with radio and television reception. This equipment has been tested and found to comply with the limits for a Class B digital device in accordance with the specifications in part 15 of the FCC rules. These specifications are designed to provide reasonable protection against such interference in a residential installation. However, there is no guarantee that interference will not occur in a particular installation.

Modifying the equipment without Cisco's written authorization may result in the equipment no longer complying with FCC requirements for Class A or Class B digital devices. In that event, your right to use the equipment may be limited by FCC regulations, and you may be required to correct any interference to radio or television communications at your own expense.

You can determine whether your equipment is causing interference by turning it off. If the interference stops, it was probably caused by the Cisco equipment or one of its peripheral devices. If the equipment causes interference to radio or television reception, try to correct the interference by using one or more of the following measures:

- Turn the television or radio antenna until the interference stops.
- Move the equipment to one side or the other of the television or radio.
- Move the equipment farther away from the television or radio.
- Plug the equipment into an outlet that is on a different circuit from the television or radio. (That is, make certain the equipment and the television or radio are on circuits controlled by different circuit breakers or fuses.)

Modifications to this product not authorized by Cisco Systems, Inc. could void the FCC approval and negate your authority to operate the product.

The Cisco implementation of TCP header compression is an adaptation of a program developed by the University of California, Berkeley (UCB) as part of UCB's public domain version of the UNIX operating system. All rights reserved. Copyright © 1981, Regents of the University of California.

NOTWITHSTANDING ANY OTHER WARRANTY HEREIN, ALL DOCUMENT FILES AND SOFTWARE OF THESE SUPPLIERS ARE PROVIDED "AS IS" WITH ALL FAULTS. CISCO AND THE ABOVE-NAMED SUPPLIERS DISCLAIM ALL WARRANTIES, EXPRESSED OR IMPLIED, INCLUDING, WITHOUT LIMITATION, THOSE OF MERCHANTABILITY, FITNESS FOR A PARTICULAR PURPOSE AND NONINFRINGEMENT OR ARISING FROM A COURSE OF DEALING, USAGE, OR TRADE PRACTICE.

IN NO EVENT SHALL CISCO OR ITS SUPPLIERS BE LIABLE FOR ANY INDIRECT, SPECIAL, CONSEQUENTIAL, OR INCIDENTAL DAMAGES, INCLUDING, WITHOUT LIMITATION, LOST PROFITS OR LOSS OR DAMAGE TO DATA ARISING OUT OF THE USE OR INABILITY TO USE THIS MANUAL, EVEN IF CISCO OR ITS SUPPLIERS HAVE BEEN ADVISED OF THE POSSIBILITY OF SUCH DAMAGES.

Cisco and the Cisco logo are trademarks or registered trademarks of Cisco and/or its affiliates in the U.S. and other countries. To view a list of Cisco trademarks, go to this URL: www.cisco.com/go/trademarks. Third-party trademarks mentioned are the property of their respective owners. The use of the word partner does not imply a partnership relationship between Cisco and any other company. (1110R)

Any Internet Protocol (IP) addresses used in this document are not intended to be actual addresses. Any examples, command display output, and figures included in the document are shown for illustrative purposes only. Any use of actual IP addresses in illustrative content is unintentional and coincidental.

Cisco ONS 15454 Reference Manual, Release 7.0.1

Copyright © 2000–2012 Cisco Systems, Inc. All rights reserved.



CONTENTS

About this Manual	xxxix
Revision History	xxxix
Document Objectives	xli
Audience	xli
Document Organization	xlii
Related Documentation	xliii
Document Conventions	xliv
Obtaining Optical Networking Information	I
Where to Find Safety and Warning Information	I
Cisco Optical Networking Product Documentation CD-ROM	I
Obtaining Documentation and Submitting a Service Request	I

CHAPTER 1

Shelf and Backplane Hardware	1-1
1.1 Overview	1-2
1.2 Rack Installation	1-3
1.2.1 Reversible Mounting Bracket	1-4
1.2.2 Mounting a Single Node	1-5
1.2.3 Mounting Multiple Nodes	1-5
1.2.4 ONS 15454 Bay Assembly	1-6
1.3 Front Door	1-6
1.4 Backplane Covers	1-10
1.4.1 Lower Backplane Cover	1-11
1.4.2 Rear Cover	1-12
1.4.3 Alarm Interface Panel	1-13
1.4.4 Alarm Interface Panel Replacement	1-13
1.5 Electrical Interface Assemblies	1-14
1.5.1 EIA Installation	1-15
1.5.2 EIA Configurations	1-15
1.5.3 BNC EIA	1-17
1.5.3.1 BNC Connectors	1-18
1.5.3.2 BNC Insertion and Removal Tool	1-19
1.5.4 High-Density BNC EIA	1-19
1.5.5 MiniBNC EIA	1-20
1.5.5.1 MiniBNC Connectors	1-21

1.5.5.2	MiniBNC Insertion and Removal Tool	1-26
1.5.6	SMB EIA	1-27
1.5.7	AMP Champ EIA	1-28
1.5.8	UBIC-V EIA	1-32
1.5.9	UBIC-H EIA	1-33
1.5.10	EIA Replacement	1-37
1.6	Coaxial Cable	1-37
1.7	DS-1 Cable	1-37
1.7.1	Twisted Pair Wire-Wrap Cables	1-37
1.7.2	Electrical Interface Adapters	1-38
1.8	UBIC-V Cables	1-39
1.9	UBIC-H Cables	1-44
1.10	Ethernet Cables	1-50
1.11	Cable Routing and Management	1-52
1.11.1	Fiber Management	1-53
1.11.2	Fiber Management Using the Tie-Down Bar	1-54
1.11.3	Coaxial Cable Management	1-55
1.11.4	DS-1 Twisted-Pair Cable Management	1-55
1.11.5	AMP Champ Cable Management	1-55
1.12	Alarm Expansion Panel	1-55
1.12.1	Wire-Wrap and Pin Connections	1-56
1.13	Filler Card	1-60
1.14	Fan-Tray Assembly	1-61
1.14.1	Fan Speed and Power Requirements	1-62
1.14.2	Fan Failure	1-62
1.14.3	Air Filter	1-63
1.15	Power and Ground Description	1-63
1.16	Alarm, Timing, LAN, and Craft Pin Connections	1-64
1.16.1	Alarm Contact Connections	1-66
1.16.2	Timing Connections	1-67
1.16.3	LAN Connections	1-67
1.16.4	TL1 Craft Interface Installation	1-68
1.17	Cards and Slots	1-68
1.17.1	Card Slot Requirements	1-69
1.17.2	Card Replacement	1-72
1.17.3	Ferrites	1-72
1.18	Software and Hardware Compatibility	1-73

CHAPTER 2**Common Control Cards 2-1**

- 2.1 Common Control Card Overview 2-1
 - 2.1.1 Cards Summary 2-1
 - 2.1.2 Card Compatibility 2-3
 - 2.1.3 Cross-Connect Card Compatibility 2-3
- 2.2 TCC2 Card 2-6
 - 2.2.1 TCC2 Card Functionality 2-7
 - 2.2.2 TCC2 Card-Level Indicators 2-8
 - 2.2.3 Network-Level Indicators 2-9
 - 2.2.4 Power-Level Indicators 2-10
- 2.3 TCC2P Card 2-10
 - 2.3.1 TCC2P Functionality 2-11
 - 2.3.2 TCC2P Card-Level Indicators 2-13
 - 2.3.3 Network-Level Indicators 2-13
 - 2.3.4 Power-Level Indicators 2-14
- 2.4 XCVT Card 2-14
 - 2.4.1 XCVT Functionality 2-15
 - 2.4.2 VT Mapping 2-16
 - 2.4.3 XCVT Hosting DS3XM-6 or DS3XM-12 2-17
 - 2.4.4 XCVT Card-Level Indicators 2-17
- 2.5 XC10G Card 2-18
 - 2.5.1 XC10G Functionality 2-19
 - 2.5.2 VT Mapping 2-20
 - 2.5.3 XC10G Hosting DS3XM-6 or DS3XM-12 2-21
 - 2.5.4 XC10G Card-Level Indicators 2-21
 - 2.5.5 XCVT/XC10G/XC-VXC-10G Compatibility 2-22
- 2.6 XC-VXC-10G Card 2-22
 - 2.6.1 XC-VXC-10G Functionality 2-23
 - 2.6.2 VT Mapping 2-25
 - 2.6.3 XC-VXC-10G Hosting DS3XM-6 or DS3XM-12 2-26
 - 2.6.4 XC-VXC-10G Card-Level Indicators 2-26
 - 2.6.5 XC-VXC-10G Compatibility 2-27
- 2.7 AIC-I Card 2-27
 - 2.7.1 AIC-I Card-Level Indicators 2-28
 - 2.7.2 External Alarms and Controls 2-29
 - 2.7.3 Orderwire 2-30
 - 2.7.4 Power Monitoring 2-31
 - 2.7.5 User Data Channel 2-31
 - 2.7.6 Data Communications Channel 2-32

CHAPTER 3**Electrical Cards 3-1**

- 3.1 Electrical Card Overview 3-1
 - 3.1.1 Card Summary 3-1
 - 3.1.2 Card Compatibility 3-3
- 3.2 EC1-12 Card 3-3
 - 3.2.1 EC1-12 Slots and Connectors 3-4
 - 3.2.2 EC1-12 Faceplate and Block Diagram 3-4
 - 3.2.3 EC1-12 Hosted by XCVT, XC10G, or XC-VXC-10G 3-5
 - 3.2.4 EC1-12 Card-Level Indicators 3-5
 - 3.2.5 EC1-12 Port-Level Indicators 3-5
- 3.3 DS1-14 and DS1N-14 Cards 3-5
 - 3.3.1 DS1N-14 Features and Functions 3-6
 - 3.3.2 DS1-14 and DS1N-14 Slot Compatibility 3-6
 - 3.3.3 DS1-14 and DS1N-14 Faceplate and Block Diagram 3-6
 - 3.3.4 DS1-14 and DS1N-14 Hosted by XCVT, XC10G, or XC-VXC-10G 3-8
 - 3.3.5 DS1-14 and DS1N-14 Card-Level Indicators 3-8
 - 3.3.6 DS1-14 and DS1N-14 Port-Level Indicators 3-9
- 3.4 DS1/E1-56 Card 3-9
 - 3.4.1 DS1/E1-56 Slots and Connectors 3-9
 - 3.4.2 DS1/E1-56 Faceplate and Block Diagram 3-10
 - 3.4.3 DS1/E1-56 Card-Level Indicators 3-11
 - 3.4.4 DS1/E1-56 Port-Level Indicators 3-12
- 3.5 DS3-12 and DS3N-12 Cards 3-12
 - 3.5.1 DS3-12 and DS3N-12 Slots and Connectors 3-13
 - 3.5.2 DS3-12 and DS3N-12 Faceplate and Block Diagram 3-13
 - 3.5.3 DS3-12 and DS3N-12 Card-Level Indicators 3-14
 - 3.5.4 DS3-12 and DS3N-12 Port-Level Indicators 3-15
- 3.6 DS3/EC1-48 Card 3-15
 - 3.6.1 DS3/EC1-48 Slots and Connectors 3-15
 - 3.6.2 DS3/EC1-48 Faceplate and Block Diagram 3-16
 - 3.6.3 DS3/EC1-48 Card-Level Indicators 3-17
 - 3.6.4 DS3/EC1-48 Port-Level Indicators 3-18
- 3.7 DS3i-N-12 Card 3-18
 - 3.7.1 DS3i-N-12 Slots and Connectors 3-18
 - 3.7.2 DS3i-N-12 Card-Level Indicators 3-20
 - 3.7.3 DS3i-N-12 Port-Level Indicators 3-20
- 3.8 DS3-12E and DS3N-12E Cards 3-20
 - 3.8.1 DS3-12E and DS3N-12E Slots and Connectors 3-21
 - 3.8.2 DS3-12E Faceplate and Block Diagram 3-21

3.8.3	DS3-12E and DS3N-12E Card-Level Indicators	3-23
3.8.4	DS3-12E and DS3N-12E Port-Level Indicators	3-24
3.9	DS3XM-6 Card	3-24
3.9.1	DS3XM-6 Slots and Connectors	3-24
3.9.2	DS3XM-6 Faceplate and Block Diagram	3-24
3.9.3	DS3XM-6 Hosted By XCVT	3-25
3.9.4	DS3XM-6 Card-Level Indicators	3-25
3.9.5	DS3XM-6 Port-Level Indicators	3-26
3.10	DS3XM-12 Card	3-26
3.10.1	Backplane Configurations	3-26
3.10.2	Ported Mode	3-27
3.10.3	Portless Mode	3-27
3.10.4	Shelf Configurations	3-27
3.10.5	Protection Modes	3-28
3.10.6	Card Features	3-28
3.10.7	DS3XM-12 Slots and Connectors	3-29
3.10.8	DS3XM-12 Faceplate and Block Diagram	3-29
3.10.9	DS3XM-12 Card-Level Indicators	3-30
3.10.10	DS3XM-12 Port-Level Indicators	3-31

CHAPTER 4**Optical Cards 4-1**

4.1	Optical Card Overview	4-2
4.1.1	Card Summary	4-2
4.1.2	Card Compatibility	4-4
4.2	OC3 IR 4/STM1 SH 1310 Card	4-5
4.2.1	OC3 IR 4/STM1 SH 1310 Card-Level Indicators	4-7
4.2.2	OC3 IR 4/STM1 SH 1310 Port-Level Indicators	4-7
4.3	OC3 IR/STM1 SH 1310-8 Card	4-7
4.3.1	OC3 IR/STM1 SH 1310-8 Card-Level Indicators	4-9
4.3.2	OC3 IR/STM1 SH 1310-8 Port-Level Indicators	4-9
4.4	OC12 IR/STM4 SH 1310 Card	4-9
4.4.1	OC12 IR/STM4 SH 1310 Card-Level Indicators	4-10
4.4.2	OC12 IR/STM4 SH 1310 Port-Level Indicators	4-11
4.5	OC12 LR/STM4 LH 1310 Card	4-11
4.5.1	OC12 LR/STM4 LH 1310 Card-Level Indicators	4-12
4.5.2	OC12 LR/STM4 LH 1310 Port-Level Indicators	4-13
4.6	OC12 LR/STM4 LH 1550 Card	4-13
4.6.1	OC12 LR/STM4 LH 1550 Card-Level Indicators	4-14
4.6.2	OC12 LR/STM4 LH 1550 Port-Level Indicators	4-15

4.7	OC12 IR/STM4 SH 1310-4 Card	4-15	
4.7.1	OC12 IR/STM4 SH 1310-4 Card-Level Indicators		4-17
4.7.2	OC12 IR/STM4 SH 1310-4 Port-Level Indicators		4-17
4.8	OC48 IR 1310 Card	4-17	
4.8.1	OC48 IR 1310 Card-Level Indicators		4-18
4.8.2	OC48 IR 1310 Port-Level Indicators		4-19
4.9	OC48 LR 1550 Card	4-19	
4.9.1	OC48 LR 1550 Card-Level Indicators		4-20
4.9.2	OC48 LR 1550 Port-Level Indicators		4-21
4.10	OC48 IR/STM16 SH AS 1310 Card	4-21	
4.10.1	OC48 IR/STM16 SH AS 1310 Card-Level Indicators		4-22
4.10.2	OC48 IR/STM16 SH AS 1310 Port-Level Indicators		4-23
4.11	OC48 LR/STM16 LH AS 1550 Card	4-23	
4.11.1	OC48 LR/STM16 LH AS 1550 Card-Level Indicators		4-24
4.11.2	OC48 LR/STM16 LH AS 1550 Port-Level Indicators		4-25
4.12	OC48 ELR/STM16 EH 100 GHz Cards	4-25	
4.12.1	OC48 ELR 100 GHz Card-Level Indicators		4-27
4.12.2	OC48 ELR 100 GHz Port-Level Indicators		4-27
4.13	OC48 ELR 200 GHz Cards	4-27	
4.13.1	OC48 ELR 200 GHz Card-Level Indicators		4-29
4.13.2	OC48 ELR 200 GHz Port-Level Indicators		4-29
4.14	OC192 SR/STM64 IO 1310 Card	4-29	
4.14.1	OC192 SR/STM64 IO 1310 Card-Level Indicators		4-30
4.14.2	OC192 SR/STM64 IO 1310 Port-Level Indicators		4-31
4.15	OC192 IR/STM64 SH 1550 Card	4-31	
4.15.1	OC192 IR/STM64 SH 1550 Card-Level Indicators		4-32
4.15.2	OC192 IR/STM64 SH 1550 Port-Level Indicators		4-33
4.16	OC192 LR/STM64 LH 1550 Card	4-33	
4.16.1	OC192 LR/STM64 LH 1550 Card-Level Indicators		4-38
4.16.2	OC192 LR/STM64 LH 1550 Port-Level Indicators		4-38
4.17	OC192 LR/STM64 LH ITU 15xx.xx Card	4-38	
4.17.1	OC192 LR/STM64 LH ITU 15xx.xx Card-Level Indicators		4-40
4.17.2	OC192 LR/STM64 LH ITU 15xx.xx Port-Level Indicators		4-41
4.18	15454_MRC-12 Multirate Card	4-41	
4.18.1	Slot Compatibility by Cross-Connect Card		4-42
4.18.2	Ports and Line Rates		4-43
4.18.3	15454_MRC-12 Card-Level Indicators		4-45
4.18.4	15454_MRC-12 Port-Level Indicators		4-46

4.19	OC192SR1/STM64IO Short Reach and OC192/STM64 Any Reach Cards	4-46
4.19.1	OC192SR1/STM64IO Short Reach and OC192/STM64 Any Reach Card-Level Indicators	4-49
4.19.2	OC192SR1/STM64IO Short Reach and OC-192/STM-64 Any Reach Port-Level Indicators	4-49
4.20	Optical Card SFPs and XFPs	4-49
4.20.1	Compatibility by Card	4-49
4.20.2	SFP Description	4-50
4.20.3	XFP Description	4-51
4.20.4	PPM Provisioning	4-52

CHAPTER 5**Ethernet Cards 5-1**

5.1	Ethernet Card Overview	5-1
5.1.1	Ethernet Cards	5-2
5.1.2	Card Compatibility	5-3
5.2	E100T-12 Card	5-3
5.2.1	Slot Compatibility	5-5
5.2.2	E100T-12 Card-Level Indicators	5-5
5.2.3	E100T-12 Port-Level Indicators	5-5
5.2.4	Cross-Connect Compatibility	5-5
5.3	E100T-G Card	5-6
5.3.1	Slot Compatibility	5-7
5.3.2	E100T-G Card-Level Indicators	5-7
5.3.3	E100T-G Port-Level Indicators	5-7
5.3.4	Cross-Connect Compatibility	5-8
5.4	E1000-2 Card	5-8
5.4.1	Slot Compatibility	5-10
5.4.2	E1000-2 Card-Level Indicators	5-10
5.4.3	E1000-2 Port-Level Indicators	5-10
5.4.4	Cross-Connect Compatibility	5-10
5.5	E1000-2-G Card	5-11
5.5.1	E1000-2-G Card-Level Indicators	5-13
5.5.2	E1000-2-G Port-Level Indicators	5-13
5.5.3	Cross-Connect Compatibility	5-13
5.6	G1000-4 Card	5-14
5.6.1	STS-24c Restriction	5-15
5.6.2	G1000-4 Card-Level Indicators	5-15
5.6.3	G1000-4 Port-Level Indicators	5-15
5.6.4	Slot Compatibility	5-16
5.7	G1K-4 Card	5-16

- 5.7.1 STS-24c Restriction 5-17
- 5.7.2 G1K-4 Compatibility 5-18
- 5.7.3 G1K-4 Card-Level Indicators 5-18
- 5.7.4 G1K-4 Port-Level Indicators 5-18
- 5.8 ML100T-12 Card 5-19
 - 5.8.1 ML100T-12 Card-Level Indicators 5-20
 - 5.8.2 ML100T-12 Port-Level Indicators 5-21
 - 5.8.3 Cross-Connect and Slot Compatibility 5-21
- 5.9 ML100X-8 Card 5-21
 - 5.9.1 ML100X-8 Card-Level Indicators 5-23
 - 5.9.2 ML100X-8 Port-Level Indicators 5-23
 - 5.9.3 Cross-Connect and Slot Compatibility 5-23
- 5.10 ML1000-2 Card 5-23
 - 5.10.1 ML1000-2 Card-Level Indicators 5-25
 - 5.10.2 ML1000-2 Port-Level Indicators 5-25
 - 5.10.3 Cross-Connect and Slot Compatibility 5-25
- 5.11 CE-100T-8 Card 5-25
 - 5.11.1 CE-100T-8 Card-Level Indicators 5-27
 - 5.11.2 CE-100T-8 Port-Level Indicators 5-27
 - 5.11.3 Cross-Connect and Slot Compatibility 5-28
- 5.12 CE-1000-4 Card 5-28
 - 5.12.1 CE-1000-4 Card-Level Indicators 5-30
 - 5.12.2 CE-1000-4 Port-Level Indicators 5-31
 - 5.12.3 Cross-Connect and Slot Compatibility 5-31
- 5.13 Ethernet Card GBICs and SFPs 5-31
 - 5.13.1 Compatibility by Card 5-31
 - 5.13.2 GBIC Description 5-32
 - 5.13.3 G-1K-4 DWDM and CWDM GBICs 5-33
 - 5.13.4 SFP Description 5-35

CHAPTER 6

Storage Access Networking Cards 6-1

- 6.1 FC_MR-4 Card Overview 6-1
 - 6.1.1 FC_MR-4 Card-Level Indicators 6-3
 - 6.1.2 FC_MR-4 Port-Level Indicators 6-4
 - 6.1.3 FC_MR-4 Compatibility 6-4
- 6.2 FC_MR-4 Card Modes 6-4
 - 6.2.1 Line-Rate Card Mode 6-4
 - 6.2.2 Enhanced Card Mode 6-5
 - 6.2.2.1 Mapping 6-5

6.2.2.2	SW -LCAS	6-5
6.2.2.3	Distance Extension	6-5
6.2.2.4	Differential Delay Features	6-6
6.2.2.5	Interoperability Features	6-6
6.2.3	Link Integrity	6-6
6.2.4	Link Recovery	6-7
6.3	FC_MR-4 Card Application	6-7
6.4	FC_MR-4 Card GBICs	6-8

CHAPTER 7**Card Protection 7-1**

7.1	Electrical Card Protection	7-1
7.1.1	1:1 Protection	7-2
7.1.2	1:N Protection	7-3
7.1.2.1	Revertive Switching	7-4
7.1.2.2	1:N Protection Guidelines	7-4
7.2	Electrical Card Protection and the Backplane	7-5
7.2.1	Standard BNC Protection	7-11
7.2.2	High-Density BNC Protection	7-11
7.2.3	MiniBNC Protection	7-12
7.2.4	SMB Protection	7-12
7.2.5	AMP Champ Protection	7-12
7.2.6	UBIC Protection	7-12
7.3	OC-N Card Protection	7-13
7.3.1	1+1 Protection	7-13
7.3.2	Optimized 1+1 Protection	7-13
7.4	Unprotected Cards	7-14
7.5	External Switching Commands	7-14

CHAPTER 8**Cisco Transport Controller Operation 8-1**

8.1	CTC Software Delivery Methods	8-1
8.1.1	CTC Software Installed on the TCC2/TCC2P Card	8-1
8.1.2	CTC Software Installed on the PC or UNIX Workstation	8-3
8.2	CTC Installation Overview	8-3
8.3	PC and UNIX Workstation Requirements	8-4
8.4	ONS 15454 Connection	8-6
8.5	CTC Window	8-7
8.5.1	Node View	8-8
8.5.1.1	CTC Card Colors	8-8

- 8.5.1.2 Node View Card Shortcuts 8-10
- 8.5.1.3 Node View Tabs 8-10
- 8.5.2 Network View 8-11
 - 8.5.2.1 Network View Tabs 8-12
 - 8.5.2.2 CTC Node Colors 8-13
 - 8.5.2.3 DCC Links 8-13
 - 8.5.2.4 Link Consolidation 8-13
- 8.5.3 Card View 8-14
- 8.5.4 Print or Export CTC Data 8-16
- 8.6 TCC2/TCC2P Card Reset 8-17
- 8.7 TCC2/TCC2P Card Database 8-17
- 8.8 Software Revert 8-18

CHAPTER 9

Security 9-1

- 9.1 User IDs and Security Levels 9-1
- 9.2 User Privileges and Policies 9-1
 - 9.2.1 User Privileges by CTC Action 9-2
 - 9.2.2 Security Policies 9-6
 - 9.2.2.1 Superuser Privileges for Provisioning Users 9-6
 - 9.2.2.2 Idle User Timeout 9-6
 - 9.2.2.3 User Password, Login, and Access Policies 9-6
 - 9.2.2.4 Secure Access 9-7
- 9.3 Audit Trail 9-7
 - 9.3.1 Audit Trail Log Entries 9-7
 - 9.3.2 Audit Trail Capacities 9-8
- 9.4 RADIUS Security 9-8
 - 9.4.1 RADIUS Authentication 9-8
 - 9.4.2 Shared Secrets 9-9

CHAPTER 10

Timing 10-1

- 10.1 Timing Parameters 10-1
- 10.2 Network Timing 10-2
- 10.3 Synchronization Status Messaging 10-3

CHAPTER 11

Circuits and Tunnels 11-1

- 11.1 Overview 11-2
- 11.2 Circuit Properties 11-2
 - 11.2.1 Concatenated STS Time Slot Assignments 11-4

11.2.2	Circuit Status	11-6
11.2.3	Circuit States	11-7
11.2.4	Circuit Protection Types	11-9
11.2.5	Circuit Information in the Edit Circuit Window	11-10
11.3	Cross-Connect Card Bandwidth	11-12
11.4	Portless Transmux	11-15
11.5	DCC Tunnels	11-16
11.5.1	Traditional DCC Tunnels	11-17
11.5.2	IP-Encapsulated Tunnels	11-18
11.6	SDH Tunneling	11-18
11.7	Multiple Destinations for Unidirectional Circuits	11-18
11.8	Monitor Circuits	11-19
11.9	Path Protection Circuits	11-19
11.9.1	Open-Ended Path Protection Circuits	11-20
11.9.2	Go-and-Return Path Protection Routing	11-20
11.10	BLSR Protection Channel Access Circuits	11-21
11.11	BLSR STS and VT Squelch Tables	11-22
11.11.1	BLSR STS Squelch Table	11-22
11.11.2	BLSR VT Squelch Table	11-22
11.12	Section and Path Trace	11-23
11.13	Path Signal Label, C2 Byte	11-24
11.14	Automatic Circuit Routing	11-26
11.14.1	Bandwidth Allocation and Routing	11-27
11.14.2	Secondary Sources and Destinations	11-27
11.15	Manual Circuit Routing	11-28
11.16	Constraint-Based Circuit Routing	11-32
11.17	Virtual Concatenated Circuits	11-33
11.17.1	VCAT Circuit States	11-33
11.17.2	VCAT Member Routing	11-33
11.17.3	Link Capacity Adjustment	11-34
11.17.4	VCAT Circuit Size	11-35
11.18	Bridge and Roll	11-36
11.18.1	Rolls Window	11-37
11.18.2	Roll Status	11-38
11.18.3	Single and Dual Rolls	11-39
11.18.4	Two Circuit Bridge and Roll	11-41
11.18.5	Protected Circuits	11-42
11.19	Merged Circuits	11-42

11.20 Reconfigured Circuits 11-43
 11.21 VLAN Management 11-43
 11.22 Server Trails 11-43

CHAPTER 12

SONET Topologies and Upgrades 12-1

12.1 SONET Rings and TCC2/TCC2P Cards 12-1
 12.2 Bidirectional Line Switched Rings 12-3
 12.2.1 Two-Fiber BLSRs 12-3
 12.2.2 Four-Fiber BLSRs 12-6
 12.2.3 BLSR Bandwidth 12-9
 12.2.4 BLSR Application Example 12-10
 12.2.5 BLSR Fiber Connections 12-13
 12.3 Comparison of the Protection Schemes 12-14
 12.4 Linear ADM Configurations 12-15
 12.5 Path-Protected Mesh Networks 12-15
 12.6 Four-Shelf Node Configurations 12-17
 12.7 OC-N Speed Upgrades 12-18
 12.7.1 Span Upgrade Wizard 12-20
 12.7.2 Manual Span Upgrades 12-20
 12.8 In-Service Topology Upgrades 12-21
 12.8.1 Unprotected Point-to-Point or Linear ADM to Path Protection 12-22
 12.8.2 Point-to-Point or Linear ADM to Two-Fiber BLSR 12-22
 12.8.3 Path Protection to Two-Fiber BLSR 12-23
 12.8.4 Two-Fiber BLSR to Four-Fiber BLSR 12-23
 12.8.5 Add or Remove a Node from a Topology 12-23

CHAPTER 13

Management Network Connectivity 13-1

13.1 IP Networking Overview 13-1
 13.2 IP Addressing Scenarios 13-2
 13.2.1 IP Scenario 1: CTC and ONS 15454s on Same Subnet 13-3
 13.2.2 IP Scenario 2: CTC and ONS 15454 Nodes Connected to a Router 13-3
 13.2.3 IP Scenario 3: Using Proxy ARP to Enable an ONS 15454 Gateway 13-4
 13.2.4 IP Scenario 4: Default Gateway on a CTC Computer 13-6
 13.2.5 IP Scenario 5: Using Static Routes to Connect to LANs 13-7
 13.2.6 IP Scenario 6: Using OSPF 13-10
 13.2.7 IP Scenario 7: Provisioning the ONS 15454 SOCKS Proxy Server 13-12
 13.2.8 IP Scenario 8: Dual GNEs on a Subnet 13-18
 13.2.9 IP Scenario 9: IP Addressing with Secure Mode Enabled 13-20

13.2.9.1	Secure Mode Behavior	13-20
13.2.9.2	Secure Node Locked and Unlocked Behavior	13-23
13.3	Provisionable Patchcords	13-24
13.4	Routing Table	13-26
13.5	External Firewalls	13-27
13.6	Open GNE	13-29
13.7	TCP/IP and OSI Networking	13-31
13.7.1	Point-to-Point Protocol	13-32
13.7.2	Link Access Protocol on the D Channel	13-33
13.7.3	OSI Connectionless Network Service	13-33
13.7.4	OSI Routing	13-36
13.7.4.1	End System-to-Intermediate System Protocol	13-38
13.7.4.2	Intermediate System-to-Intermediate System Protocol	13-38
13.7.5	TARP	13-39
13.7.5.1	TARP Processing	13-40
13.7.5.2	TARP Loop Detection Buffer	13-41
13.7.5.3	Manual TARP Adjacencies	13-41
13.7.5.4	Manual TID to NSAP Provisioning	13-42
13.7.6	TCP/IP and OSI Mediation	13-42
13.7.7	OSI Virtual Routers	13-43
13.7.8	IP-over-CLNS Tunnels	13-45
13.7.8.1	Provisioning IP-over-CLNS Tunnels	13-46
13.7.8.2	IP-over-CLNS Tunnel Scenario 1: ONS Node to Other Vendor GNE	13-47
13.7.8.3	IP-over-CLNS Tunnel Scenario 2: ONS Node to Router	13-48
13.7.8.4	IP-over-CLNS Tunnel Scenario 3: ONS Node to Router Across an OSI DCN	13-49
13.7.9	OSI/IP Networking Scenarios	13-51
13.7.9.1	OSI/IP Scenario 1: IP OSS, IP DCN, ONS GNE, IP DCC, and ONS ENE	13-52
13.7.9.2	OSI/IP Scenario 2: IP OSS, IP DCN, ONS GNE, OSI DCC, and Other Vendor ENE	13-52
13.7.9.3	OSI/IP Scenario 3: IP OSS, IP DCN, Other Vendor GNE, OSI DCC, and ONS ENE	13-54
13.7.9.4	OSI/IP Scenario 4: Multiple ONS DCC Areas	13-56
13.7.9.5	OSI/IP Scenario 5: GNE Without an OSI DCC Connection	13-57
13.7.9.6	OSI/IP Scenario 6: IP OSS, OSI DCN, ONS GNE, OSI DCC, and Other Vendor ENE	13-58
13.7.9.7	OSI/IP Scenario 7: OSI OSS, OSI DCN, Other Vender GNE, OSI DCC, and ONS NEs	13-59
13.7.9.8	OSI/IP Scenario 8: OSI OSS, OSI DCN, ONS GNE, OSI DCC, and Other Vender NEs	13-61
13.7.10	Provisioning OSI in CTC	13-63

CHAPTER 14

Alarm Monitoring and Management 14-1

- 14.1 Overview 14-1
- 14.2 LCD Alarm Counts 14-1
- 14.3 Alarm Information 14-2
 - 14.3.1 Viewing Alarms With Each Node's Time Zone 14-4
 - 14.3.2 Controlling Alarm Display 14-4
 - 14.3.3 Filtering Alarms 14-4
 - 14.3.4 Viewing Alarm-Affected Circuits 14-5
 - 14.3.5 Conditions Tab 14-5
 - 14.3.6 Controlling the Conditions Display 14-6
 - 14.3.6.1 Retrieving and Displaying Conditions 14-6
 - 14.3.6.2 Conditions Column Descriptions 14-6
 - 14.3.6.3 Filtering Conditions 14-7
 - 14.3.7 Viewing History 14-7
 - 14.3.7.1 History Column Descriptions 14-8
 - 14.3.7.2 Retrieving and Displaying Alarm and Condition History 14-8
 - 14.3.8 Alarm History and Log Buffer Capacities 14-9
- 14.4 Alarm Severities 14-9
- 14.5 Alarm Profiles 14-9
 - 14.5.1 Creating and Modifying Alarm Profiles 14-10
 - 14.5.2 Alarm Profile Buttons 14-11
 - 14.5.3 Alarm Profile Editing 14-12
 - 14.5.4 Alarm Severity Options 14-12
 - 14.5.5 Row Display Options 14-12
 - 14.5.6 Applying Alarm Profiles 14-13
- 14.6 Alarm Suppression 14-13
 - 14.6.1 Alarms Suppressed for Maintenance 14-13
 - 14.6.2 Alarms Suppressed by User Command 14-14
- 14.7 External Alarms and Controls 14-14
 - 14.7.1 External Alarms 14-14
 - 14.7.2 External Controls 14-15

CHAPTER 15

Performance Monitoring 15-1

- 15.1 Threshold Performance Monitoring 15-1
- 15.2 Intermediate Path Performance Monitoring 15-3
- 15.3 Pointer Justification Count Performance Monitoring 15-4
- 15.4 Performance Monitoring Parameter Definitions 15-4
- 15.5 Performance Monitoring for Electrical Cards 15-12

15.5.1	EC1-12 Card Performance Monitoring Parameters	15-12
15.5.2	DS1_E1_56 Card Performance Monitoring Parameters	15-14
15.5.3	DS1-14 and DS1N-14 Card Performance Monitoring Parameters	15-16
15.5.3.1	DS-1 Facility Data Link Performance Monitoring	15-18
15.5.4	DS3-12 and DS3N-12 Card Performance Monitoring Parameters	15-18
15.5.5	DS3-12E and DS3N-12E Card Performance Monitoring Parameters	15-19
15.5.6	DS3i-N-12 Card Performance Monitoring Parameters	15-21
15.5.7	DS3XM-6 Card Performance Monitoring Parameters	15-23
15.5.8	DS3XM-12 Card Performance Monitoring Parameters	15-25
15.5.9	DS3-EC1-48 Card Performance Monitoring Parameters	15-27
15.6	Performance Monitoring for Ethernet Cards	15-29
15.6.1	E-Series Ethernet Card Performance Monitoring Parameters	15-29
15.6.1.1	E-Series Ethernet Statistics Window	15-29
15.6.1.2	E-Series Ethernet Utilization Window	15-31
15.6.1.3	E-Series Ethernet History Window	15-31
15.6.2	G-Series Ethernet Card Performance Monitoring Parameters	15-32
15.6.2.1	G-Series Ethernet Statistics Window	15-32
15.6.2.2	G-Series Ethernet Utilization Window	15-33
15.6.2.3	G-Series Ethernet History Window	15-34
15.6.3	ML-Series Ethernet Card Performance Monitoring Parameters	15-34
15.6.3.1	ML-Series Ether Ports Window	15-34
15.6.3.2	ML-Series POS Ports Window	15-35
15.6.4	CE-Series Ethernet Card Performance Monitoring Parameters	15-37
15.6.4.1	CE-Series Card Ether Port Statistics Window	15-37
15.6.4.2	CE-Series Card Ether Ports Utilization Window	15-40
15.6.4.3	CE-Series Card Ether Ports History Window	15-40
15.6.4.4	CE-Series Card POS Ports Statistics Parameters	15-40
15.6.4.5	CE-Series Card POS Ports Utilization Window	15-41
15.6.4.6	CE-Series Card Ether Ports History Window	15-41
15.7	Performance Monitoring for Optical Cards	15-42
15.8	Performance Monitoring for Optical Multirate Cards	15-44
15.9	Performance Monitoring for Storage Access Networking Cards	15-45
15.9.1	FC_MR-4 Statistics Window	15-45
15.9.2	FC_MR-4 Utilization Window	15-47
15.9.3	FC_MR-4 History Window	15-48

CHAPTER 16**SNMP 16-1**

16.1	SNMP Overview	16-1
16.2	Basic SNMP Components	16-2

- 16.3 SNMP External Interface Requirement **16-4**
- 16.4 SNMP Version Support **16-4**
- 16.5 SNMP Message Types **16-4**
- 16.6 SNMP Management Information Bases **16-5**
 - 16.6.1 IETF-Standard MIBs for the ONS 15454 **16-5**
 - 16.6.2 Proprietary ONS 15454 MIBs **16-6**
 - 16.6.3 Generic Threshold and Performance Monitoring MIBs **16-7**
- 16.7 SNMP Trap Content **16-8**
 - 16.7.1 Generic and IETF Traps **16-9**
 - 16.7.2 Variable Trap Bindings **16-10**
- 16.8 SNMP Community Names **16-16**
- 16.9 Proxy Over Firewalls **16-16**
- 16.10 Remote Monitoring **16-16**
 - 16.10.1 64-Bit RMON Monitoring over DCC **16-17**
 - 16.10.1.1 Row Creation in MediaIndependentTable **16-17**
 - 16.10.1.2 Row Creation in cMediaIndependentHistoryControlTable **16-17**
 - 16.10.2 HC-RMON-MIB Support **16-18**
 - 16.10.3 Ethernet Statistics RMON Group **16-18**
 - 16.10.3.1 Row Creation in etherStatsTable **16-18**
 - 16.10.3.2 Get Requests and GetNext Requests **16-18**
 - 16.10.3.3 Row Deletion in etherStatsTable **16-18**
 - 16.10.3.4 64-Bit etherStatsHighCapacity Table **16-19**
 - 16.10.4 History Control RMON Group **16-19**
 - 16.10.4.1 History Control Table **16-19**
 - 16.10.4.2 Row Creation in historyControlTable **16-19**
 - 16.10.4.3 Get Requests and GetNext Requests **16-20**
 - 16.10.4.4 Row Deletion in historyControl Table **16-20**
 - 16.10.5 Ethernet History RMON Group **16-20**
 - 16.10.5.1 64-Bit etherHistoryHighCapacityTable **16-20**
 - 16.10.6 Alarm RMON Group **16-20**
 - 16.10.6.1 Alarm Table **16-20**
 - 16.10.6.2 Row Creation in alarmTable **16-21**
 - 16.10.6.3 Get Requests and GetNext Requests **16-22**
 - 16.10.6.4 Row Deletion in alarmTable **16-22**
 - 16.10.7 Event RMON Group **16-22**
 - 16.10.7.1 Event Table **16-23**
 - 16.10.7.2 Log Table **16-23**

APPENDIX A**Hardware Specifications A-1**

- A.1 Shelf Specifications **A-1**
 - A.1.1 Bandwidth **A-1**
 - A.1.2 Configurations **A-1**
 - A.1.3 Cisco Transport Controller **A-2**
 - A.1.4 External LAN Interface **A-2**
 - A.1.5 TL1 Craft Interface **A-2**
 - A.1.6 Modem Interface **A-2**
 - A.1.7 Alarm Interface **A-2**
 - A.1.8 EIA Interface **A-3**
 - A.1.9 BITS Interface **A-3**
 - A.1.10 System Timing **A-3**
 - A.1.11 System Power **A-3**
 - A.1.12 System Environmental Specifications **A-3**
 - A.1.13 Dimensions **A-4**
- A.2 SFP, XFP, and GBIC Specifications **A-4**
- A.3 General Card Specifications **A-6**
 - A.3.1 Power **A-6**
 - A.3.2 Temperature **A-8**
- A.4 Common Control Card Specifications **A-10**
 - A.4.1 TCC2 Card Specifications **A-10**
 - A.4.2 TCC2P Card Specifications **A-11**
 - A.4.3 XCVT Card Specifications **A-12**
 - A.4.4 XC10G Card Specifications **A-12**
 - A.4.5 XC-XVC-10G Card Specifications **A-13**
 - A.4.6 AIC-I Card Specifications **A-13**
 - A.4.7 AEP Specifications **A-14**
- A.5 Electrical Card Specifications **A-15**
 - A.5.1 EC1-12 Card Specifications **A-15**
 - A.5.2 DS1-14 and DS1N-14 Card Specifications **A-16**
 - A.5.3 DS1/E1-56 Card Specifications **A-18**
 - A.5.4 DS3/EC1-48 Card Specifications **A-19**
 - A.5.5 DS3-12 and DS3N-12 Card Specifications **A-20**
 - A.5.6 DS3i-N-12 Card Specifications **A-21**
 - A.5.7 DS3-12E and DS3N-12E Card Specifications **A-22**
 - A.5.8 DS3XM-12 Card Specifications **A-23**
 - A.5.9 DS3XM-6 Card Specifications **A-24**
 - A.5.10 FILLER Card Specifications **A-25**
- A.6 Optical Card Specifications **A-25**

A.6.1	OC3 IR 4/STM1 SH 1310 Card Specifications	A-26
A.6.2	OC3 IR/STM1SH 1310-8 Card Specifications	A-27
A.6.3	OC12 IR/STM4 SH 1310 Card Specifications	A-28
A.6.4	OC12 LR/STM4 LH 1310 Card Specifications	A-29
A.6.5	OC12 LR/STM4 LH 1550 Card Specifications	A-30
A.6.6	OC12 IR/STM4 SH 1310-4 Specifications	A-31
A.6.7	OC48 IR 1310 Card Specifications	A-32
A.6.8	OC48 LR 1550 Card Specifications	A-33
A.6.9	OC48 IR/STM16 SH AS 1310 Card Specifications	A-33
A.6.10	OC48 LR/STM16 LH AS 1550 Card Specifications	A-34
A.6.11	OC48 ELR/STM 16 EH 100 GHz Card Specifications	A-35
A.6.12	OC48 ELR 200 GHz Card Specifications	A-36
A.6.13	OC192 SR/STM64 IO 1310 Card Specifications	A-37
A.6.14	OC192 IR/STM64 SH 1550 Card Specifications	A-38
A.6.15	OC192 LR/STM64 LH 1550 Card Specifications	A-39
A.6.16	OC192 LR/STM64 LH ITU 15xx.xx Card Specifications	A-40
A.6.17	15454_MRC-12 Card Specifications	A-42
A.6.18	OC192SR1/STM64IO Short Reach Card Specifications	A-43
A.6.19	OC192/STM64 Any Reach Card Specifications	A-44
A.7	Ethernet Card Specifications	A-45
A.7.1	E100T-12 Card Specifications	A-45
A.7.2	E100T-G Card Specifications	A-45
A.7.3	E1000-2 Card Specifications	A-46
A.7.4	E1000-2-G Card Specifications	A-46
A.7.5	CE-1000-4 Card Specifications	A-46
A.7.6	CE-100T-8 Card Specifications	A-47
A.7.7	G1K-4 Card Specifications	A-47
A.7.8	ML100T-12 Card Specifications	A-47
A.7.9	ML1000-2 Card Specifications	A-48
A.7.10	ML100X-8 Card Specifications	A-48
A.8	Storage Access Networking Card Specifications	A-49
A.8.1	FC_MR-4 Card Specifications	A-49

APPENDIX B

Administrative and Service States B-1

B.1	Service States	B-1
B.2	Administrative States	B-2
B.3	Service State Transitions	B-3
B.3.1	Card Service State Transitions	B-3
B.3.2	Port and Cross-Connect Service State Transitions	B-5

APPENDIX C**Network Element Defaults C-1**

- C.1 Network Element Defaults Description **C-1**
- C.2 Card Default Settings **C-2**
 - C.2.1 Configuration Defaults **C-2**
 - C.2.2 Threshold Defaults **C-3**
 - C.2.3 Defaults by Card **C-4**
 - C.2.3.1 DS-1 Card Default Settings **C-4**
 - C.2.3.2 DS1/E1-56 Card Default Settings **C-7**
 - C.2.3.3 DS-3 Card Default Settings **C-12**
 - C.2.3.4 DS3/EC1-48 Card Default Settings **C-14**
 - C.2.3.5 DS3E Card Default Settings **C-18**
 - C.2.3.6 DS3I Card Default Settings **C-20**
 - C.2.3.7 DS3XM-6 Card Default Settings **C-22**
 - C.2.3.8 DS3XM-12 Card Default Settings **C-25**
 - C.2.3.9 EC1-12 Card Default Settings **C-29**
 - C.2.3.10 FC_MR-4 Card Default Settings **C-31**
 - C.2.3.11 Ethernet Card Default Settings **C-32**
 - C.2.3.12 OC-3 Card Default Settings **C-32**
 - C.2.3.13 OC3-8 Card Default Settings **C-35**
 - C.2.3.14 OC-12 Card Default Settings **C-39**
 - C.2.3.15 OC12-4 Card Default Settings **C-42**
 - C.2.3.16 OC-48 Card Default Settings **C-46**
 - C.2.3.17 OC-192 Card Default Settings **C-50**
 - C.2.3.18 OC192-XFP Default Settings **C-54**
 - C.2.3.19 MRC-12 Card Default Settings **C-60**
- C.3 Node Default Settings **C-74**
 - C.3.1 Time Zones **C-83**
- C.4 CTC Default Settings **C-86**

INDEX



FIGURES

Figure 1-1	Cisco ONS 15454 ANSI Dimensions	4
Figure 1-2	Mounting an ONS 15454 in a Rack	5
Figure 1-3	The ONS 15454 Front Door	6
Figure 1-4	Cisco ONS 15454 Deep Door	7
Figure 1-5	ONS 15454 Front Door Ground Strap	8
Figure 1-6	Removing the ONS 15454 Front Door	9
Figure 1-7	Front-Door Erasable Label	10
Figure 1-8	Laser Warning on the Front-Door Label	10
Figure 1-9	Backplane Covers	11
Figure 1-10	Removing the Lower Backplane Cover	11
Figure 1-11	Backplane Attachment for Cover	12
Figure 1-12	Installing the Plastic Rear Cover with Spacers	13
Figure 1-13	BNC Backplane for Use in 1:1 Protection Schemes	18
Figure 1-14	BNC Insertion and Removal Tool	19
Figure 1-15	High-Density BNC Backplane for Use in 1:N Protection Schemes	20
Figure 1-16	MiniBNC Backplane for Use in 1:N Protection Schemes	22
Figure 1-17	MiniBNC Insertion and Removal Tool	27
Figure 1-18	SMB EIA Backplane	28
Figure 1-19	AMP Champ EIA Backplane	29
Figure 1-20	UBIC-V Slot Designations	32
Figure 1-21	UBIC-H EIA Connector Labeling	34
Figure 1-22	DS-1 Electrical Interface Adapter (Balun)	38
Figure 1-23	Cable Connector Pins	39
Figure 1-24	UBIC-V DS-1 Cable Schematic Diagram	41
Figure 1-25	UBIC-V DS-3/EC-1 Cable Schematic Diagram	44
Figure 1-26	Cable Connector Pins	46
Figure 1-27	UBIC-H DS-1 Cable Schematic Diagram	47
Figure 1-28	UBIC-H DS-3/EC-1 Cable Schematic Diagram	50
Figure 1-29	100BaseT Connector Pins	51
Figure 1-30	Straight-Through Cable	51

Figure 1-31	Crossover Cable	52
Figure 1-32	Managing Cables on the Front Panel	53
Figure 1-33	Fiber Capacity	53
Figure 1-34	Tie-Down Bar	54
Figure 1-35	AEP Printed Circuit Board Assembly	56
Figure 1-36	AEP Block Diagram	56
Figure 1-37	AEP Wire-Wrap Connections to Backplane Pins	57
Figure 1-38	Alarm Input Circuit Diagram	58
Figure 1-39	Alarm Output Circuit Diagram	59
Figure 1-40	Detectable Filler Card Faceplate	61
Figure 1-41	Ground Posts on the ONS 15454 Backplane	64
Figure 1-42	ONS 15454 Backplane Pinouts (Release 3.4 or Later)	65
Figure 1-43	ONS 15454 Backplane Pinouts	66
Figure 1-44	Installing Cards in the ONS 15454	69
Figure 2-1	TCC2 Card Faceplate and Block Diagram	7
Figure 2-2	TCC2P Faceplate and Block Diagram	11
Figure 2-3	XCVT Faceplate and Block Diagram	15
Figure 2-4	XCVT Cross-Connect Matrix	16
Figure 2-5	XC10G Faceplate and Block Diagram	19
Figure 2-6	XC10G Cross-Connect Matrix	20
Figure 2-7	XC-VXC-10G Faceplate and Block Diagram	23
Figure 2-8	XC-VXC-10G Cross-Connect Matrix	25
Figure 2-9	AIC-I Faceplate and Block Diagram	28
Figure 2-10	RJ-11 Connector	31
Figure 3-1	EC1-12 Faceplate and Block Diagram	4
Figure 3-2	DS1-14 Faceplate and Block Diagram	7
Figure 3-3	DS1N-14 Faceplate and Block Diagram	8
Figure 3-4	DS1/E1-56 Faceplate and Block Diagram	11
Figure 3-5	DS3-12 Faceplate and Block Diagram	13
Figure 3-6	DS3N-12 Faceplate and Block Diagram	14
Figure 3-7	DS3/EC1-48 Faceplate and Block Diagram	17
Figure 3-8	DS3i-N-12 Faceplate and Block Diagram	19
Figure 3-9	DS3-12E Faceplate and Block Diagram	22
Figure 3-10	DS3N-12E Faceplate and Block Diagram	23
Figure 3-11	DS3XM-6 Faceplate and Block Diagram	25

Figure 3-12	DS3XM-12 Faceplate and Block Diagram	30
Figure 4-1	OC3 IR 4/STM1 SH 1310 Faceplate and Block Diagram	6
Figure 4-2	OC3IR/STM1 SH 1310-8 Faceplate and Block Diagram	8
Figure 4-3	OC12 IR/STM4 SH 1310 Faceplate and Block Diagram	10
Figure 4-4	OC12 LR/STM4 LH 1310 Faceplate and Block Diagram	12
Figure 4-5	OC12 LR/STM4 LH 1550 Faceplate and Block Diagram	14
Figure 4-6	OC12 IR/STM4 SH 1310-4 Faceplate and Block Diagram	16
Figure 4-7	OC48 IR 1310 Faceplate and Block Diagram	18
Figure 4-8	OC48 LR 1550 Faceplate and Block Diagram	20
Figure 4-9	OC48 IR/STM16 SH AS 1310 Faceplate and Block Diagram	22
Figure 4-10	OC48 LR/STM16 LH AS 1550 Faceplate and Block Diagram	24
Figure 4-11	OC48 ELR/STM16 EH 100 GHz Faceplate and Block Diagram	26
Figure 4-12	OC48 ELR 200 GHz Faceplate and Block Diagram	28
Figure 4-13	OC192 SR/STM64 IO 1310 Faceplate and Block Diagram	30
Figure 4-14	OC192 IR/STM64 SH 1550 Faceplate and Block Diagram	32
Figure 4-15	OC192 LR/STM64 LH 1550 (15454-OC192LR1550) Faceplate and Block Diagram	34
Figure 4-16	Enlarged Section of the OC192 LR/STM64 LH 1550 (15454-OC192LR1550) Faceplate	35
Figure 4-17	OC192 LR/STM64 LH 1550 (15454-OC192-LR2) Faceplate and Block Diagram	36
Figure 4-18	Enlarged Section of the OC192 LR/STM64 LH 1550 (15454-OC192-LR2)Faceplate	37
Figure 4-19	OC192 LR/STM64 LH ITU 15xx.xx Faceplate	39
Figure 4-20	OC192 LR/STM64 LH ITU 15xx.xx Block Diagram	40
Figure 4-21	15454_MRC-12 Card Faceplate and Block Diagram	42
Figure 4-22	OC192SR1/STM64IO Short Reach and OC192/STM64 Any Reach Card Faceplates and Block Diagram	48
Figure 4-23	Mylar Tab SFP	50
Figure 4-24	Actuator/Button SFP	51
Figure 4-25	Bail Clasp SFP	51
Figure 4-26	Bail Clasp XFP (Unlatched)	52
Figure 4-27	Bail Clasp XFP (Latched)	52
Figure 5-1	E100T-12 Faceplate and Block Diagram	4
Figure 5-2	E100T-G Faceplate and Block Diagram	6
Figure 5-3	E1000-2 Faceplate and Block Diagram	9
Figure 5-4	E1000-2-G Faceplate and Block Diagram	12
Figure 5-5	G1000-4 Faceplate and Block Diagram	14
Figure 5-6	G1K-4 Faceplate and Block Diagram	17
Figure 5-7	ML100T-12 Faceplate and Block Diagram	20

Figure 5-8	ML100X-8 Faceplate and Block Diagram	22
Figure 5-9	ML1000-2 Faceplate	24
Figure 5-10	CE-100T-8 Faceplate and Block Diagram	26
Figure 5-11	CE-1000-4 Faceplate and Block Diagram	30
Figure 5-12	GBICs with Clips (left) and with a Handle (right)	33
Figure 5-13	CWDM GBIC with Wavelength Appropriate for Fiber-Connected Device	34
Figure 5-14	G-Series with CWDM/DWDM GBICs in Cable Network	35
Figure 5-15	Mylar Tab SFP	35
Figure 5-16	Actuator/Button SFP	36
Figure 5-17	Bail Clasp SFP	36
Figure 6-1	FC_MR-4 Faceplate and Block Diagram	3
Figure 7-1	Example: ONS 15454 Cards in a 1:1 Protection Configuration (SMB EIA)	2
Figure 7-2	Example: ONS 15454 Cards in a 1:N Protection Configuration (SMB EIA)	3
Figure 7-3	Unprotected Low-Density Electrical Card Schemes for EIA Types	7
Figure 7-4	Unprotected High-Density Electrical Card Schemes for EIA Types	8
Figure 7-5	1:1 Protection Schemes for Low-Density Electrical Cards with EIA Types	9
Figure 7-6	1:N Protection Schemes for Low-Density Electrical Cards with EIA Types	10
Figure 7-7	1:1 Protection Schemes for High-Density Electrical Cards with UBIC or MiniBNC EIA Types	11
Figure 7-8	ONS 15454 in an Unprotected Configuration	14
Figure 8-1	CTC Software Versions, Node View	2
Figure 8-2	CTC Software Versions, Network View	2
Figure 8-3	Node View (Default Login View)	8
Figure 8-4	Terminal Loopback Indicator	10
Figure 8-5	Facility Loopback Indicator	10
Figure 8-6	Network in CTC Network View	12
Figure 8-7	CTC Card View Showing a DS1 Card	15
Figure 10-1	ONS 15454 Timing Example	2
Figure 11-1	ONS 15454 Circuit Window in Network View	4
Figure 11-2	BLSR Circuit Displayed on the Detailed Circuit Map	12
Figure 11-3	One VT1.5 Circuit on One STS	13
Figure 11-4	Two VT1.5 Circuits in a BLSR	14
Figure 11-5	Traditional DCC Tunnel	17
Figure 11-6	VT1.5 Monitor Circuit Received at an EC1-12 Port	19
Figure 11-7	Editing Path Protection Selectors	20
Figure 11-8	Path Protection Go-and-Return Routing	21

Figure 11-9	Secondary Sources and Destinations	27
Figure 11-10	Alternate Paths for Virtual Path Protection Segments	29
Figure 11-11	Mixing 1+1 or BLSR Protected Links With a Path Protection	29
Figure 11-12	Ethernet Shared Packet Ring Routing	30
Figure 11-13	Ethernet and Path Protection	30
Figure 11-14	VCAT Common Fiber Routing	33
Figure 11-15	VCAT Split Fiber Routing	34
Figure 11-16	Rolls Window	37
Figure 11-17	Single Source Roll	39
Figure 11-18	Single Destination Roll	40
Figure 11-19	Single Roll from One Circuit to Another Circuit (Destination Changes)	40
Figure 11-20	Single Roll from One Circuit to Another Circuit (Source Changes)	40
Figure 11-21	Dual Roll to Reroute a Link	41
Figure 11-22	Dual Roll to Reroute to a Different Node	41
Figure 12-1	Four-Node, Two-Fiber BLSR	4
Figure 12-2	Four-Node, Two-Fiber BLSR Traffic Pattern Sample	5
Figure 12-3	Four-Node, Two-Fiber BLSR Traffic Pattern Following Line Break	6
Figure 12-4	Four-Node, Four-Fiber BLSR	7
Figure 12-5	Four-Fiber BLSR Span Switch	8
Figure 12-6	Four-Fiber BLSR Ring Switch	9
Figure 12-7	BLSR Bandwidth Reuse	10
Figure 12-8	Five-Node Two-Fiber BLSR	11
Figure 12-9	Shelf Assembly Layout for Node 0 in Figure 12-8	12
Figure 12-10	Shelf Assembly Layout for Nodes 1 to 4 in Figure 12-8	12
Figure 12-11	Connecting Fiber to a Four-Node, Two-Fiber BLSR	13
Figure 12-12	Connecting Fiber to a Four-Node, Four-Fiber BLSR	14
Figure 12-13	Linear (Point-to-Point) ADM Configuration	15
Figure 12-14	Path-Protected Mesh Network	16
Figure 12-15	PPMN Virtual Ring	17
Figure 12-16	Four-Shelf Node Configuration	18
Figure 12-17	Unprotected Point-to-Point ADM to Path Protection Conversion	22
Figure 13-1	IP Scenario 1: CTC and ONS 15454s on Same Subnet	3
Figure 13-2	IP Scenario 2: CTC and ONS 15454 Nodes Connected to a Router	4
Figure 13-3	IP Scenario 3: Using Proxy ARP	5
Figure 13-4	IP Scenario 3: Using Proxy ARP with Static Routing	6

Figure 13-5	IP Scenario 4: Default Gateway on a CTC Computer	7
Figure 13-6	IP Scenario 5: Static Route With One CTC Computer Used as a Destination	8
Figure 13-7	IP Scenario 5: Static Route With Multiple LAN Destinations	9
Figure 13-8	IP Scenario 6: OSPF Enabled	11
Figure 13-9	IP Scenario 6: OSPF Not Enabled	12
Figure 13-10	SOCKS Proxy Server Gateway Settings	13
Figure 13-11	IP Scenario 7: ONS 15454 SOCKS Proxy Server with GNE and ENes on the Same Subnet	15
Figure 13-12	IP Scenario 7: ONS 15454 SOCKS Proxy Server with GNE and ENes on Different Subnets	16
Figure 13-13	IP Scenario 7: ONS 15454 SOCKS Proxy Server With ENes on Multiple Rings	17
Figure 13-14	IP Scenario 8: Dual GNEs on the Same Subnet	19
Figure 13-15	IP Scenario 8: Dual GNEs on Different Subnets	20
Figure 13-16	. IP Scenario 9: ONS 15454 GNE and ENes on the Same Subnet with Secure Mode Enabled	22
Figure 13-17	IP Scenario 9: ONS 15454 GNE and ENes on Different Subnets with Secure Mode Enabled	23
Figure 13-18	Proxy and Firewall Tunnels for Foreign Terminations	30
Figure 13-19	Foreign Node Connection to an ENE Ethernet Port	31
Figure 13-20	ISO-DCC NSAP Address	35
Figure 13-21	OSI Main Setup	36
Figure 13-22	Level 1 and Level 2 OSI Routing	37
Figure 13-23	Manual TARP Adjacencies	42
Figure 13-24	T–TD Protocol Flow	43
Figure 13-25	FT–TD Protocol Flow	43
Figure 13-26	Provisioning OSI Routers	44
Figure 13-27	IP-over-CLNS Tunnel Flow	46
Figure 13-28	IP-over-CLNS Tunnel Scenario 1: ONS NE to Other Vender GNE	48
Figure 13-29	IP-over-CLNS Tunnel Scenario 2: ONS Node to Router	49
Figure 13-30	IP-over-CLNS Tunnel Scenario 3: ONS Node to Router Across an OSI DCN	51
Figure 13-31	OSI/IP Scenario 1: IP OSS, IP DCN, ONS GNE, IP DCC, and ONS ENE	52
Figure 13-32	OSI/IP Scenario 2: IP OSS, IP DCN, ONS GNE, OSI DCC, and Other Vendor ENE	53
Figure 13-33	OSI/IP Scenario 3: IP OSS, IP DCN, Other Vendor GNE, OSI DCC, and ONS ENE	55
Figure 13-34	OSI/IP Scenario 3 with OSI/IP-over-CLNS Tunnel Endpoint at the GNE	56
Figure 13-35	OSI/IP Scenario 4: Multiple ONS DCC Areas	57
Figure 13-36	OSI/IP Scenario 5: GNE Without an OSI DCC Connection	58
Figure 13-37	OSI/IP Scenario 6: IP OSS, OSI DCN, ONS GNE, OSI DCC, and Other Vendor ENE	59
Figure 13-38	OSI/IP Scenario 7: OSI OSS, OSI DCN, Other Vender GNE, OSI DCC, and ONS NEs	60
Figure 13-39	OSI/IP Scenario 8: OSI OSS, OSI DCN, ONS GNE, OSI DCC, and Other Vender NEs	62

Figure 14-1	Shelf LCD Panel	2
Figure 14-2	Select Affected Circuits Option	5
Figure 14-3	Network View Alarm Profiles Window	10
Figure 14-4	DS1 Card Alarm Profile	13
Figure 15-1	TCAs Displayed in CTC	2
Figure 15-2	Monitored Signal Types for the EC1-12 Card	12
Figure 15-3	PM Read Points on the EC1-12 Card	13
Figure 15-4	Monitored Signal Types for the DS1/E1-56 Card	14
Figure 15-5	PM Read Points on the DS1/E1-56 Card	15
Figure 15-6	Monitored Signal Types for the DS1-14 and DS1N-14 Cards	16
Figure 15-7	PM Read Points on the DS1-14 and DS1N-14 Cards	17
Figure 15-8	Monitored Signal Types for the DS3-12 and DS3N-12 Cards	18
Figure 15-9	PM Read Points on the DS3-12 and DS3N-12 Cards	19
Figure 15-10	Monitored Signal Types for the DS3-12E and DS3N-12E Cards	20
Figure 15-11	PM Read Points on the DS3-12E and DS3N-12E Cards	20
Figure 15-12	Monitored Signal Types for the DS3i-N-12 Cards	21
Figure 15-13	PM Read Points on the DS3i-N-12 Cards	22
Figure 15-14	Monitored Signal Types for the DS3XM-6 Card	23
Figure 15-15	PM Read Points on the DS3XM-6 Card	24
Figure 15-16	Monitored Signal Types for the DS3XM-12 Card	25
Figure 15-17	PM Read Points on the DS3XM-12 Card	26
Figure 15-18	Monitored Signal Types for the DS3/EC1-48 Card	27
Figure 15-19	PM Read Points on the DS3/EC1-48 Card	28
Figure 15-20	Monitored Signal Types for the OC-3 Cards	42
Figure 15-21	PM Read Points on the OC-3 Cards	42
Figure 15-22	PM Read Points for the MRC-12 Card	44
Figure 16-1	Basic Network Managed by SNMP	2
Figure 16-2	Example of the Primary SNMP Components	3
Figure 16-3	Agent Gathering Data from a MIB and Sending Traps to the Manager	3



T A B L E S

Table 1	Cisco ONS 15454 Reference Manual Chapters	xlii
Table 1-1	EIA Types Compatible with the 15454-SA-ANSI Only	15
Table 1-2	EIA Configurations Compatible with the 15454-SA-ANSI and the 15454-SA-HD	16
Table 1-3	MiniBNC Protection Types and Slots	21
Table 1-4	J-Labeling Port Assignments for a Shelf Assembly Configure with Low-Density Electrical Cards (A Side)	23
Table 1-5	J-Labeling Port Assignments for a Shelf Assembly Configured with Low-Density Electrical Cards (B Side)	24
Table 1-6	J-Labeling Port Assignments for a Shelf Configured with High-Density Electrical Cards (A Side)	25
Table 1-7	J-Labeling Port Assignments for a Shelf Configured with High-Density Electrical Cards (B Side)	26
Table 1-8	AMP Champ Connector Pin Assignments	30
Table 1-9	AMP Champ Connector Pin Assignments (Shielded DS-1 Cable)	30
Table 1-10	UBIC-V Protection Types and Slots	33
Table 1-11	J-Labeling Port Assignments for a Shelf Assembly Configured with Low-Density Electrical Cards (A Side)	35
Table 1-12	J-Labeling Port Assignments for a Shelf Assembly Configured with Low-Density Electrical Cards (B Side)	35
Table 1-13	J-Labeling Port Assignments for a Shelf Configured with High-Density Electrical Cards (A Side)	36
Table 1-14	J-Labeling Port Assignments for a Shelf Configured with High-Density Electrical Cards (B Side)	36
Table 1-15	UBIC-H Protection Types and Slots	37
Table 1-16	UBIC-V DS-1 SCSI Connector Pin Out	40
Table 1-17	UBIC-V DS-1 Tip/Ring Color Coding	42
Table 1-18	UBIC-V DS-3/EC-1 SCSI Connector Pin Out	42
Table 1-19	UBIC-H DS-1 SCSI Connector Pin Out	46
Table 1-20	UBIC-H DS-1 Tip/Ring Color Coding	48
Table 1-21	UBIC-H DS-3/EC-1 SCSI Connector Pin Out	48
Table 1-22	E100-TX Connector Pinout	51
Table 1-23	Fiber Channel Capacity (One Side of the Shelf)	54
Table 1-24	Pin Assignments for the AEP	57
Table 1-25	Alarm Input Pin Association	58
Table 1-26	Pin Association for Alarm Output Pins	59
Table 1-27	Fan Tray Assembly Power Requirements	62
Table 1-28	BITS External Timing Pin Assignments	67
Table 1-29	LAN Pin Assignments	68

Table 1-30	Craft Interface Pin Assignments	68
Table 1-31	Slot and Card Symbols	70
Table 1-32	Card Ports, Line Rates, and Connectors	70
Table 1-33	ONS 15454 Software and Hardware Compatibility—XC and XCVT Configurations	73
Table 1-34	ONS 15454 Software and Hardware Compatibility—XC10G and XC-VXC-10G Configurations	75
Table 2-1	Common Control Card Functions	2
Table 2-2	Common-Control Card Software Release Compatibility	3
Table 2-3	Common-Control Card Cross-Connect Compatibility	3
Table 2-4	Electrical Card Cross-Connect Compatibility	4
Table 2-5	Optical Card Cross-Connect Compatibility	4
Table 2-6	Ethernet Card Cross-Connect Compatibility	5
Table 2-7	SAN Card Cross-Connect Compatibility	6
Table 2-8	TCC2 Card-Level Indicators	9
Table 2-9	TCC2 Network-Level Indicators	9
Table 2-10	TCC2 Power-Level Indicators	10
Table 2-11	TCC2P Card-Level Indicators	13
Table 2-12	TCC2P Network-Level Indicators	13
Table 2-13	TCC2P Power-Level Indicators	14
Table 2-14	VT Mapping	16
Table 2-15	XCVT Card-Level Indicators	18
Table 2-16	VT Mapping	20
Table 2-17	XC10G Card-Level Indicators	21
Table 2-18	VT Mapping	25
Table 2-19	XC-VXC-10G Card-Level Indicators	26
Table 2-20	AIC-I Card-Level Indicators	28
Table 2-21	Orderwire Pin Assignments	31
Table 2-22	UDC Pin Assignments	32
Table 2-23	DCC Pin Assignments	32
Table 3-1	Cisco ONS 15454 Electrical Cards	2
Table 3-2	Electrical Card Software Release Compatibility	3
Table 3-3	EC1-12 Card-Level Indicators	5
Table 3-4	DS1-14 and DS1N-14 Card-Level Indicators	9
Table 3-5	DS1/E1-56 Slot Restrictions	10
Table 3-6	DS1/E1-56 Card-Level Indicators	12
Table 3-7	DS3-12 and DS3N-12 Card-Level Indicators	14

Table 3-8	DS3/EC1-48 Slot Restrictions	15
Table 3-9	DS3/EC1-48 Card-Level Indicators	18
Table 3-10	DS3i-N-12 Card-Level Indicators	20
Table 3-11	DS3-12E and DS3N-12E Card-Level Indicators	23
Table 3-12	DS3XM-6 Card-Level Indicators	26
Table 3-13	DS3XM-12 Shelf Configurations	27
Table 3-14	DS3XM-12 Features	28
Table 3-15	DS3XM-12 Card-Level Indicators	31
Table 4-1	Optical Cards for the ONS 15454	2
Table 4-2	Optical Card Software Release Compatibility	4
Table 4-3	OC3 IR 4/STM1 SH 1310 Card-Level Indicators	7
Table 4-4	OC3IR/STM1 SH 1310-8 Card-Level Indicators	9
Table 4-5	OC12 IR/STM4 SH 1310 Card-Level Indicators	11
Table 4-6	OC12 LR/STM4 LH 1310 Card-Level Indicators	13
Table 4-7	OC12 LR/STM4 LH 1550 Card-Level Indicators	15
Table 4-8	OC12 IR/STM4 SH 1310-4 Card-Level Indicators	17
Table 4-9	OC48 IR 1310 Card-Level Indicators	19
Table 4-10	OC48 LR 1550 Card-Level Indicators	21
Table 4-11	OC48 IR/STM16 SH AS 1310 Card-Level Indicators	23
Table 4-12	OC48 LR/STM16 LH AS 1550 Card-Level Indicators	25
Table 4-13	OC48 ELR/STM16 EH 100 GHz Card-Level Indicators	27
Table 4-14	OC48 ELR 200 GHz Card-Level Indicators	29
Table 4-15	OC192 SR/STM64 IO 1310 Card-Level Indicators	31
Table 4-16	OC192 IR/STM64 SH 1550 Card-Level Indicators	33
Table 4-17	OC192 LR/STM64 LH 1550 Card-Level Indicators	38
Table 4-18	OC192 LR/STM64 LH ITU 15xx.xx Card-Level Indicators	41
Table 4-19	Maximum Bandwidth by Shelf Slot for the 15454_MRC-12 in Different Cross-Connect Configurations	43
Table 4-20	Line Rate Configurations Per 15454_MRC-12 Port, Based on Available Bandwidth	44
Table 4-21	15454_MRC-12 Card-Level Indicators	46
Table 4-22	OC192SR1/STM64IO Short Reach and OC192/STM64 Any Reach Card-Level Indicators	49
Table 4-23	SFP and XFP Card Compatibility	50
Table 5-1	Ethernet Cards for the ONS 15454	2
Table 5-2	Ethernet Card Software Compatibility	3
Table 5-3	E100T-12 Card-Level Indicators	5
Table 5-4	E100T-12 Port-Level Indicators	5

Table 5-5	E100T-G Card-Level Indicators	7
Table 5-6	E100T-G Port-Level Indicators	8
Table 5-7	E1000-2 Card-Level Indicators	10
Table 5-8	E1000-2 Port-Level Indicators	10
Table 5-9	E1000-2-G Card-Level Indicators	13
Table 5-10	E1000-2-G Port-Level Indicators	13
Table 5-11	G1000-4 Card-Level Indicators	15
Table 5-12	G1000-4 Port-Level Indicators	16
Table 5-13	G1K-4 Card-Level Indicators	18
Table 5-14	G1K-4 Port-Level Indicators	18
Table 5-15	ML100T-12 Card-Level Indicators	21
Table 5-16	ML100T-12 Port-Level Indicators	21
Table 5-17	ML100X-8 Card-Level Indicators	23
Table 5-18	ML100X-8 Port-Level Indicators	23
Table 5-19	ML1000-2 Card-Level Indicators	25
Table 5-20	ML1000-2 Port-Level Indicators	25
Table 5-21	CE-100T-8 Card-Level Indicators	27
Table 5-22	CE-100T-8 Port-Level Indicators	28
Table 5-23	CE-1000-4 Card-Level Indicators	30
Table 5-24	CE-1000-4 Port-Level Indicators	31
Table 5-25	GBIC and SFP Card Compatibility	32
Table 5-26	Supported Wavelengths for CWDM GBICs	33
Table 5-27	Supported Wavelengths for DWDM GBICs	34
Table 6-1	FC_MR-4 Card-Level Indicators	3
Table 6-2	GBIC Compatibility	8
Table 7-1	Supported 1:1 Protection by Electrical Card	2
Table 7-2	Supported 1:N Protection by Electrical Card	3
Table 7-3	EIA Connectors Per Side	5
Table 7-4	Electrical Card Protection By EIA Type	6
Table 8-1	JRE Compatibility	4
Table 8-2	Computer Requirements for CTC	5
Table 8-3	ONS 15454 Connection Methods	7
Table 8-4	Node View Card Colors	8
Table 8-5	Node View Card Statuses	9
Table 8-6	Node View Card Port Colors and Service States	9

Table 8-7	Node View Tabs and Subtabs	10
Table 8-8	Network View Tabs and Subtabs	12
Table 8-9	Node Status Shown in Network View	13
Table 8-10	DCC Colors Indicating State in Network View	13
Table 8-11	Link Icons	14
Table 8-12	Card View Tabs and Subtabs	15
Table 9-1	ONS 15454 Security Levels—Node View	2
Table 9-2	ONS 15454 Security Levels—Network View	5
Table 9-3	ONS 15454 Default User Idle Times	6
Table 9-4	Audit Trail Window Columns	7
Table 9-5	Shared Secret Character Groups	9
Table 10-1	SSM Generation 1 Message Set	3
Table 10-2	SSM Generation 2 Message Set	3
Table 11-1	STS Mapping Using CTC	4
Table 11-2	ONS 15454 Circuit Status	6
Table 11-3	Circuit Protection Types	9
Table 11-4	Port State Color Indicators	11
Table 11-5	VT Matrix Port Usage for One VT1.5 Circuit	15
Table 11-6	Portless Transmux Mapping for XCVT Drop Ports	16
Table 11-7	Portless Transmux Mapping for XCVT Trunk and XC10G or XC-VXC-10G Any-Slot Ports	16
Table 11-8	DCC Tunnels	17
Table 11-9	ONS 15454 Cards Capable of J1 Path Trace	24
Table 11-10	STS Path Signal Label Assignments for Signals	25
Table 11-11	STS Path Signal Label Assignments for Signals with Payload Defects	25
Table 11-12	Bidirectional STS/VT/Regular Multicard EtherSwitch/Point-to-Point (Straight) Ethernet Circuits	30
Table 11-13	Unidirectional STS/VT Circuit	31
Table 11-14	Multicard Group Ethernet Shared Packet Ring Circuit	31
Table 11-15	Bidirectional VT Tunnels	31
Table 11-16	ONS 15454 Card VCAT Circuit Rates and Members	35
Table 11-17	ONS 15454 VCAT Card Capabilities	36
Table 11-18	Roll Statuses	38
Table 12-1	ONS 15454 Rings with Redundant TCC2/TCC2P Cards	1
Table 12-2	Two-Fiber BLSR Capacity	9
Table 12-3	Four-Fiber BLSR Capacity	10
Table 12-4	Comparison of the Protection Schemes	14

Table 12-5	Slot 5, 6, 12, and 13 Upgrade Options	19
Table 12-6	Upgrade Options for Slots 1 through 4 and 14 through 17	19
Table 13-1	General ONS 15454 IP Troubleshooting Checklist	2
Table 13-2	ONS 15454 Gateway and End NE Settings	15
Table 13-3	SOCKS Proxy Server Firewall Filtering Rules	17
Table 13-4	SOCKS Proxy Server Firewall Filtering Rules When Packet Addressed to the ONS 15454	18
Table 13-5	Cisco ONS 15454 Client/Trunk Card Combinations for Provisionable Patchcords	24
Table 13-6	Cisco ONS 15454 Client/Client Card Combinations for Provisionable Patchcords	25
Table 13-7	Cisco ONS 15454 Trunk/Trunk Card Combinations for Provisionable Patchcords	25
Table 13-8	Sample Routing Table Entries	26
Table 13-9	Ports Used by the TCC2/TCC2P	27
Table 13-10	TCP/IP and OSI Protocols	32
Table 13-11	NSAP Fields	34
Table 13-12	TARP PDU Fields	39
Table 13-13	TARP PDU Types	39
Table 13-14	TARP Timers	40
Table 13-15	TARP Processing Flow	41
Table 13-16	OSI Virtual Router Constraints	45
Table 13-17	IP-over-CLNS Tunnel IOS Commands	47
Table 13-18	OSI Actions from the CTC Provisioning Tab	63
Table 13-19	OSI Actions from the CTC Maintenance Tab	63
Table 14-1	Alarms Column Descriptions	2
Table 14-2	Color Codes for Alarm and Condition Severities	3
Table 14-3	Alarm Display	4
Table 14-4	Conditions Display	6
Table 14-5	Conditions Column Description	6
Table 14-6	History Column Description	8
Table 14-7	Alarm Profile Buttons	11
Table 14-8	Alarm Profile Editing Options	12
Table 15-1	Electrical Cards that Report RX and TX Direction for TCAs	2
Table 15-2	ONS 15454 Line Terminating Equipment	3
Table 15-3	Performance Monitoring Parameters	5
Table 15-4	EC1-12 Card PMs	13
Table 15-5	DS1/E1-56 Card PMs	16
Table 15-6	DS1-14 and DS1N-14 Card PMs	17

Table 15-7	DS3-12 and DS3N-12 Card PMs	19
Table 15-8	DS3-12E and DS3N-12E Card PMs	21
Table 15-9	DS3i-N-12 Card PMs	22
Table 15-10	DS3XM-6 Card PMs	24
Table 15-11	DS3XM-12 Card PMs	26
Table 15-12	DS3/EC1-48 Card PMs	28
Table 15-13	E-Series Ethernet Statistics Parameters	29
Table 15-14	maxBaseRate for STS Circuits	31
Table 15-15	Ethernet History Statistics per Time Interval	31
Table 15-16	G-Series Ethernet Statistics Parameters	32
Table 15-17	ML-Series Ether Ports PM Parameters	34
Table 15-18	ML-Series POS Ports Parameters for HDLC Mode	35
Table 15-19	ML-Series POS Ports Parameters for GFP-F Mode	36
Table 15-20	CE-Series Ether Port PM Parameters	37
Table 15-21	CE-Series Card POS Ports Parameters	40
Table 15-22	OC-3 Card PMs	43
Table 15-23	OC3-8 Card PMs	43
Table 15-24	OC-12, OC-48, OC-192 Card PMs	44
Table 15-25	MRC Card PMs	45
Table 15-26	FC_MR-4 Card Statistics	45
Table 15-27	maxBaseRate for STS Circuits	47
Table 15-28	FC_MR-4 History Statistics per Time Interval	48
Table 16-1	ONS 15454 SNMP Message Types	4
Table 16-2	IETF Standard MIBs Implemented in the ONS 15454 System	5
Table 16-3	ONS 15454 Proprietary MIBs	6
Table 16-4	cerentGenericPmThresholdTable	7
Table 16-5	cerentGenericPmStatsCurrentTable	8
Table 16-6	cerentGenericPmStatsIntervalTable	8
Table 16-7	Generic IETF Traps	9
Table 16-8	ONS 15454 SNMPv2 Trap Variable Bindings	10
Table 16-9	RMON History Control Periods and History Categories	19
Table 16-10	OIDs Supported in the AlarmTable	21
Table A-1	SFP, XFP, and GBIC Specifications	4
Table A-2	Individual Card Power Requirements	6
Table A-3	Card Temperature Ranges and Product Names	8

Table B-1	ONS 15454 Service State Primary States and Primary State Qualifiers	1
Table B-2	ONS 15454 Secondary States	2
Table B-3	ONS 15454 Administrative States	3
Table B-4	ONS 15454 Card Service State Transitions	3
Table B-5	ONS 15454 Port and Cross-Connect Service State Transitions	6
Table C-1	DS-1 Card Default Settings	4
Table C-2	DS1/E1-56 Card Default Settings	7
Table C-3	DS-3 Card Default Settings	13
Table C-4	DS3/EC1-48 Card Default Settings	14
Table C-5	DS3E Card Default Settings	18
Table C-6	DS3I Card Default Settings	20
Table C-7	DS3XM-6 Card Default Settings	22
Table C-8	DS3XM-12 Card Default Settings	25
Table C-9	EC1-12 Card Default Settings	29
Table C-10	FC_MR-4 Card Default Settings	31
Table C-11	Ethernet Card Default Settings	32
Table C-12	OC-3 Card Default Settings	33
Table C-13	OC3-8 Card Default Settings	35
Table C-14	OC-12 Card Default Settings	39
Table C-15	OC12-4 Card Default Settings	42
Table C-16	OC-48 Card Default Settings	46
Table C-17	OC-192 Card Default Settings	50
Table C-18	OC192-XFP Default Settings	55
Table C-19	MRC-12 Card Default Settings	60
Table C-20	Node Default Settings	76
Table C-21	Time Zones	83
Table C-22	CTC Default Settings	86



About this Manual



Note

The terms "Unidirectional Path Switched Ring" and "UPSR" may appear in Cisco literature. These terms do not refer to using Cisco ONS 15xxx products in a unidirectional path switched ring configuration. Rather, these terms, as well as "Path Protected Mesh Network" and "PPMN," refer generally to Cisco's path protection feature, which may be used in any topological network configuration. Cisco does not recommend using its path protection feature in any particular topological network configuration.

This section explains the objectives, intended audience, and organization of this publication and describes the conventions that convey instructions and other information.

This section provides the following information:

- [Revision History](#)
- [Document Objectives](#)
- [Audience](#)
- [Document Organization](#)
- [Related Documentation](#)
- [Document Conventions](#)
- [Obtaining Optical Networking Information](#)
- [Obtaining Documentation and Submitting a Service Request](#)

Revision History

Date	Notes
March 2007	Changed fuse rating and power consumption specifications in Appendix A.
July 2007	Modified "Caution" in the "Shelf Configuration" section of the "Electrical Cards" chapter.
August 2007	Updated the note in the Path Protection Circuits section of the Circuits and Tunnels chapter.
October 2007	Updated About this Manual chapter.

Date	Notes
April 2008	<p>Added a note in the User Password, Login, and Access Policies section in the Security chapter.</p> <p>Updated note on protection switching in Link Capacity Adjustment section in Circuits and Tunnels chapter.</p>
May 2008	<p>Updated the table, Software and Hardware Compatibility—XC10G and XC-VXC-10G Configurations in the Shelf and Backplane Hardware chapter.</p> <p>Added power-level LED information for TCC2 and TCC2P cards in Common Control Cards chapter.</p>
July 2008	<p>Updated the section “15454_MRC-12 Port-Level Indicators” in the Optical Cards chapter, to show the correct number and status of the Rx indicator.</p> <p>Added DS-3/EC1-48 card support for the EIA type MiniBNC in Table 1-2, Chapter 1, Shelf and Backplane Hardware.</p> <p>Deleted the note in the Power and Ground Description section in Chapter 1, Shelf and Backplane Hardware.</p>
September 2008	<p>Added a Warning for all optical cards in Chapter 4, Optical Cards.</p> <p>Added a note in Card Default Settings and Node Default Settings section of Appendix C, Network Element Defaults.</p> <p>Updated FC_MR-4 Statistics Parameters table in the Chapter 15, Performance Monitoring.</p> <p>Updated the Software and Hardware Compatibility section in Chapter 1, Shelf and Backplane Hardware.</p>
December 2008	<ul style="list-style-type: none"> • Updated the list of PM parameters for MRC-12 card in Chapter 15, Performance Monitoring. • Updated the UBIC-V and UBIC-H sections in Chapter 1, Shelf and Backplane Hardware.
March 2009	<p>Updated Table 1-17 and Table 1-20 in UBIC-V and UBIC-H sections in Chapter 1, Shelf and Backplane Hardware.</p>
April 2009	<p>Updated section DS1/E1-56 Card Specifications in Appendix A Hardware Specifications.</p>
June 2009	<ul style="list-style-type: none"> • Updated the Figure AEP Wire-Wrap Connections to Backplane Pins in Chapter 1, Shelf and Backplane Hardware. • Updated “OC-N Speed Upgrades” in Chapter 12, SONET Topologies and Upgrades.
July 2009	<ul style="list-style-type: none"> • Updated Table 1-2 in Chapter 1, Shelf and Backplane Hardware. • Updated the “Common-Control Card Software Release Compatibility” table in the chapter 2, Common Control Cards. • Added a new section, Comparison of the Protection Schemes in the chapter, SONET Topologies and Upgrades.
August 2009	<ul style="list-style-type: none"> • Updated the first footnote in the table titled ONS 15454 Software and Hardware Compatibility—XC10G and XC-VXC-10G Configurations in the chapter, Shelf and Backplane Hardware. • Added a caution in section DS3XM-12 Card of Chapter 3, Electrical Cards.

Date	Notes
November 2009	<ul style="list-style-type: none"> Added a new section, SDH Tunneling in the chapter, Circuits and Tunnels. Updated the table “Line Rate Configurations Per 15454_MRC-12 Port, Based on Available Bandwidth” in the chapter, “Optical Cards”.
January 2010	<ul style="list-style-type: none"> Updated the section “OC-N Speed Upgrades” in the chapter SONET Topologies and Upgrades.
February 2010	<ul style="list-style-type: none"> Changed the BIEC parameter to BIT-EC in the Chapter, “Performance Monitoring”.
April 2010	<ul style="list-style-type: none"> Updated the section “SNMP Overview” in the chapter “SNMP”.
May 2010	<ul style="list-style-type: none"> Updated the note in the section “DS3/EC1-48 Card” in the chapter “Electrical Cards”.
June 2010	Updated the caution in the section “DS1/E1-56 Card” in the chapter “Electrical Cards”.
November 2010	Updated the figure “ML1000-2 Faceplate and Block Diagram” under the section “ML1000-2 Card” in the chapter “Ethernet Cards”.
June 2011	Updated the section “AIC-I Card” in the chapter “Common Control Cards”.
July 2011	<ul style="list-style-type: none"> Added a note in the “PC and UNIX Workstation Requirements” section of Chapter, “Cisco Transport Controller Operation”. Updated the tables “DS3XM-6 Card PMs” and “DS3XM-12 Card PMs” in the chapter “Performance Monitoring”.
October 2011	Updated the section “AMP Champ EIA” in the chapter, “Shelf and Backplane Hardware”.
January 2012	Updated the privileges for the Download/Cancel operations in the table, "ONS 15454 SDH Security Levels—Network View " in the chapter, “Security”.
February 2012	Updated the table “SFP and XFP Card Compatibility” in the chapter “Optical Cards”.
March 2012	<ul style="list-style-type: none"> Updated the section “TCC2P Functionality” in the chapter, “Common Control Cards”. Updated the section "DS3/EC1-48 Card Specifications" in the appendix "Hardware Specifications".
August 2012	The full length book-PDF was generated.

Document Objectives

This manual provides reference information for the Cisco ONS 15454.

Audience

To use this publication, you should be familiar with Cisco or equivalent optical transmission hardware and cabling, telecommunications hardware and cabling, electronic circuitry and wiring practices, and preferably have experience as a telecommunications technician.

Document Organization

Table 1 Cisco ONS 15454 Reference Manual Chapters

Title	Summary
Chapter 1, “Shelf and Backplane Hardware”	Includes descriptions of the rack, backplane, backplane pins, ferrites, power and ground, fan-tray assembly, air filter, card slots, cables, cable connectors, and cable routing.
Chapter 2, “Common Control Cards”	Includes descriptions of the TCC2, TCC2P, XCVT, XC-VXC-10G, XC10G, and AIC-I cards.
Chapter 3, “Electrical Cards”	Includes descriptions of EC-1, DS-1, DS-3, and DS3E cards, card temperature ranges, and compatibility.
Chapter 4, “Optical Cards”	Includes descriptions of the OC-3, OC-12, OC-48, OC-192, and MRC-12 cards, as well as card temperature ranges and card compatibility.
Chapter 5, “Ethernet Cards”	Includes descriptions of the E-Series, G-Series, and ML-Series Ethernet cards and Gigabit Interface Converters (GBICs).
Chapter 6, “Storage Access Networking Cards”	Includes descriptions of the FC_MR-4 Fiber Channel/Fiber Connectivity (FICON) card, card temperature ranges, compatibility, and applications.
Chapter 7, “Card Protection”	Includes electrical and optical card protection methods.
Chapter 8, “Cisco Transport Controller Operation”	Includes information about CTC installation, the CTC window, computer requirements, software versions, and database reset and revert.
Chapter 9, “Security”	Includes user set up information, security parameters and privileges, RADIUS authentication, and audit trail information.
Chapter 10, “Timing”	Includes node and network timing information.
Chapter 11, “Circuits and Tunnels”	Includes STS and VT, bidirectional and unidirectional, revertive and nonrevertive, electrical and optical, multiple and path trace circuit information, as well as DCC tunnels.
Chapter 12, “SONET Topologies and Upgrades”	Includes the SONET configurations used by the ONS 15454; includes bidirectional line switch rings (BLSRs), path protection configurations, linear add/drop multiplexers (ADMs), subtending rings, and optical bus configurations, as well as information about upgrading optical speeds within any configuration.

Table 1 Cisco ONS 15454 Reference Manual Chapters (continued)

Title	Summary
Chapter 13, “Management Network Connectivity”	Includes IP addressing scenarios and information about IP networking with the ONS 15454, as well as information about provisionable patchcords, the routing table, external firewalls, and open gateway network element (GNE) networks.
Chapter 14, “Alarm Monitoring and Management”	Describes CTC alarm management including alarm severities, alarm profiles, alarm suppression, and external alarms and controls.
Appendix A, “Hardware Specifications”	Provides specifications for the ONS 15454 shelf assembly, cards, and pluggable devices.
Appendix B, “Administrative and Service States”	Describes the extended state model for cards, ports, and cross-connects.
Appendix C, “Network Element Defaults”	Lists card, node, and CTC-level network element (NE) defaults.

Related Documentation

Use the *Cisco ONS 15454 Reference Manual* with the following referenced publications:

- *Cisco ONS 15454 Procedure Guide*
Provides procedures to install, turn up, provision, and maintain a Cisco ONS 15454 node and network.
- *Cisco ONS 15454 Troubleshooting Guide*
Provides general troubleshooting procedures, alarm descriptions and troubleshooting procedures, error messages, and transient conditions.
- *Cisco ONS SONET TL1 Command Guide*
Provides a full TL1 command and autonomous message set including parameters, AIDs, conditions and modifiers for the Cisco ONS 15454, ONS 15327, ONS 15600, ONS 15310-CL, and ONS 15310-MA systems.
- *Cisco ONS SONET TL1 Reference Guide*
Provides general information, procedures, and errors for TL1 in the Cisco ONS 15454, ONS 15327, ONS 15600, ONS 15310-CL, and ONS 15310-MA systems.
- *Ethernet Card Software Feature and Configuration Guide for the Cisco ONS 15454, Cisco ONS 15454 SDH, and Cisco ONS 15327*
Provides software features for all Ethernet cards and configuration information for Cisco IOS on ML-Series cards.
- *Release Notes for the Cisco ONS 15454 Release 7.0.1*
Provides caveats, closed issues, and new feature and functionality information.

For an update on End-of-Life and End-of-Sale notices, refer to

http://www.cisco.com/en/US/products/hw/optical/ps2006/prod_eol_notices_list.html

Document Conventions

This publication uses the following conventions:

Convention	Application
boldface	Commands and keywords in body text.
<i>italic</i>	Command input that is supplied by the user.
[]	Keywords or arguments that appear within square brackets are optional.
{ x x x }	A choice of keywords (represented by x) appears in braces separated by vertical bars. The user must select one.
Ctrl	The control key. For example, where Ctrl + D is written, hold down the Control key while pressing the D key.
screen font	Examples of information displayed on the screen.
boldface screen font	Examples of information that the user must enter.
< >	Command parameters that must be replaced by module-specific codes.



Note

Means *reader take note*. Notes contain helpful suggestions or references to material not covered in the document.



Caution

Means *reader be careful*. In this situation, the user might do something that could result in equipment damage or loss of data.



Warning

IMPORTANT SAFETY INSTRUCTIONS

This warning symbol means danger. You are in a situation that could cause bodily injury. Before you work on any equipment, be aware of the hazards involved with electrical circuitry and be familiar with standard practices for preventing accidents. Use the statement number provided at the end of each warning to locate its translation in the translated safety warnings that accompanied this device. Statement 1071

SAVE THESE INSTRUCTIONS

Waarschuwing

BELANGRIJKE VEILIGHEIDSINSTRUCTIES

Dit waarschuwingssymbool betekent gevaar. U verkeert in een situatie die lichamelijk letsel kan veroorzaken. Voordat u aan enige apparatuur gaat werken, dient u zich bewust te zijn van de bij elektrische schakelingen betrokken risico's en dient u op de hoogte te zijn van de standaard praktijken om ongelukken te voorkomen. Gebruik het nummer van de verklaring onderaan de waarschuwing als u een vertaling van de waarschuwing die bij het apparaat wordt geleverd, wilt raadplegen.

BEWAAR DEZE INSTRUCTIES

Varoitus

TÄRKEITÄ TURVALLISUUSOHJEITA

Tämä varoitusmerkki merkitsee vaaraa. Tilanne voi aiheuttaa ruumiillisia vammoja. Ennen kuin käsittelet laitteistoa, huomioi sähköpiirien käsittelyyn liittyvät riskit ja tutustu onnettomuuksien yleisiin ehkäisytapoihin. Turvallisuusvaroitusten käännökset löytyvät laitteen mukana toimitettujen käännettyjen turvallisuusvaroitusten joukosta varoitusten lopussa näkyvien lausuntonumeroiden avulla.

SÄILYTÄ NÄMÄ OHJEET

Attention

IMPORTANTES INFORMATIONS DE SÉCURITÉ

Ce symbole d'avertissement indique un danger. Vous vous trouvez dans une situation pouvant entraîner des blessures ou des dommages corporels. Avant de travailler sur un équipement, soyez conscient des dangers liés aux circuits électriques et familiarisez-vous avec les procédures couramment utilisées pour éviter les accidents. Pour prendre connaissance des traductions des avertissements figurant dans les consignes de sécurité traduites qui accompagnent cet appareil, référez-vous au numéro de l'instruction situé à la fin de chaque avertissement.

CONSERVEZ CES INFORMATIONS

Warnung

WICHTIGE SICHERHEITSHINWEISE

Dieses Warnsymbol bedeutet Gefahr. Sie befinden sich in einer Situation, die zu Verletzungen führen kann. Machen Sie sich vor der Arbeit mit Geräten mit den Gefahren elektrischer Schaltungen und den üblichen Verfahren zur Vorbeugung vor Unfällen vertraut. Suchen Sie mit der am Ende jeder Warnung angegebenen Anweisungsnummer nach der jeweiligen Übersetzung in den übersetzten Sicherheitshinweisen, die zusammen mit diesem Gerät ausgeliefert wurden.

BEWAHREN SIE DIESE HINWEISE GUT AUF.

Avvertenza IMPORTANTI ISTRUZIONI SULLA SICUREZZA

Questo simbolo di avvertenza indica un pericolo. La situazione potrebbe causare infortuni alle persone. Prima di intervenire su qualsiasi apparecchiatura, occorre essere al corrente dei pericoli relativi ai circuiti elettrici e conoscere le procedure standard per la prevenzione di incidenti. Utilizzare il numero di istruzione presente alla fine di ciascuna avvertenza per individuare le traduzioni delle avvertenze riportate in questo documento.

CONSERVARE QUESTE ISTRUZIONI**Advarsel VIKTIGE SIKKERHETSINSTRUKSJONER**

Dette advarselssymbolet betyr fare. Du er i en situasjon som kan føre til skade på person. Før du begynner å arbeide med noe av utstyret, må du være oppmerksom på farene forbundet med elektriske kretser, og kjenne til standardprosedyrer for å forhindre ulykker. Bruk nummeret i slutten av hver advarsel for å finne oversettelsen i de oversatte sikkerhetsadvarslene som fulgte med denne enheten.

TA VARE PÅ DISSE INSTRUKSJONENE**Aviso INSTRUÇÕES IMPORTANTES DE SEGURANÇA**

Este símbolo de aviso significa perigo. Você está em uma situação que poderá ser causadora de lesões corporais. Antes de iniciar a utilização de qualquer equipamento, tenha conhecimento dos perigos envolvidos no manuseio de circuitos elétricos e familiarize-se com as práticas habituais de prevenção de acidentes. Utilize o número da instrução fornecido ao final de cada aviso para localizar sua tradução nos avisos de segurança traduzidos que acompanham este dispositivo.

GUARDE ESTAS INSTRUÇÕES**¡Advertencia! INSTRUCCIONES IMPORTANTES DE SEGURIDAD**

Este símbolo de aviso indica peligro. Existe riesgo para su integridad física. Antes de manipular cualquier equipo, considere los riesgos de la corriente eléctrica y familiarícese con los procedimientos estándar de prevención de accidentes. Al final de cada advertencia encontrará el número que le ayudará a encontrar el texto traducido en el apartado de traducciones que acompaña a este dispositivo.

GUARDE ESTAS INSTRUCCIONES**Varning! VIKTIGA SÄKERHETSANVISNINGAR**

Denna varningssignal signalerar fara. Du befinner dig i en situation som kan leda till personskada. Innan du utför arbete på någon utrustning måste du vara medveten om farorna med elkretsar och känna till vanliga förfaranden för att förebygga olyckor. Använd det nummer som finns i slutet av varje varning för att hitta dess översättning i de översatta säkerhetsvarningar som medföljer denna anordning.

SPARA DESSA ANVISNINGAR

FONTOS BIZTONSÁGI ELOÍRÁSOK

Ez a figyelmeztető jel veszélyre utal. Sérülésveszélyt rejtő helyzetben van. Mielőtt bármely berendezésen munkát végezne, legyen figyelemmel az elektromos áramkörök okozta kockázatokra, és ismerkedjen meg a szokásos balesetvédelmi eljárásokkal. A kiadványban szereplő figyelmeztetések fordítása a készülékhez mellékelt biztonsági figyelmeztetések között található; a fordítás az egyes figyelmeztetések végén látható szám alapján kereshető meg.

ORIZZE MEG EZEKET AZ UTASÍTÁSOKAT!

Предупреждение

ВАЖНЫЕ ИНСТРУКЦИИ ПО СОБЛЮДЕНИЮ ТЕХНИКИ БЕЗОПАСНОСТИ

Этот символ предупреждения обозначает опасность. То есть имеет место ситуация, в которой следует опасаться телесных повреждений. Перед эксплуатацией оборудования выясните, каким опасностям может подвергаться пользователь при использовании электрических цепей, и ознакомьтесь с правилами техники безопасности для предотвращения возможных несчастных случаев. Воспользуйтесь номером заявления, приведенным в конце каждого предупреждения, чтобы найти его переведенный вариант в переводе предупреждений по безопасности, прилагаемом к данному устройству.

СОХРАНИТЕ ЭТИ ИНСТРУКЦИИ

警告

重要的安全性说明

此警告符号代表危险。您正处于可能受到严重伤害的工作环境中。在您使用设备开始工作之前，必须充分意识到触电的危险，并熟练掌握防止事故发生的标准工作程序。请根据每项警告结尾提供的声明号码来找到此设备的安全性警告说明的翻译文本。

请保存这些安全性说明

警告

安全上の重要な注意事項

「危険」の意味です。人身事故を予防するための注意事項が記述されています。装置の取り扱い作業を行うときは、電気回路の危険性に注意し、一般的な事故防止策に留意してください。警告の各国語版は、各注意事項の番号を基に、装置に付属の「Translated Safety Warnings」を参照してください。

これらの注意事項を保管しておいてください。

주의

중요 안전 지침

이 경고 기호는 위험을 나타냅니다. 작업자가 신체 부상을 일으킬 수 있는 위험한 환경에 있습니다. 장비에 작업을 수행하기 전에 전기 회로와 관련된 위험을 숙지하고 표준 작업 관례를 숙지하여 사고를 방지하십시오. 각 경고의 마지막 부분에 있는 경고문 번호를 참조하여 이 장치와 함께 제공되는 번역된 안전 경고문에서 해당 번역문을 찾으십시오.

이 지시 사항을 보관하십시오.

Aviso INSTRUÇÕES IMPORTANTES DE SEGURANÇA

Este símbolo de aviso significa perigo. Você se encontra em uma situação em que há risco de lesões corporais. Antes de trabalhar com qualquer equipamento, esteja ciente dos riscos que envolvem os circuitos elétricos e familiarize-se com as práticas padrão de prevenção de acidentes. Use o número da declaração fornecido ao final de cada aviso para localizar sua tradução nos avisos de segurança traduzidos que acompanham o dispositivo.

GUARDE ESTAS INSTRUÇÕES**Advarsel VIGTIGE SIKKERHEDSANVISNINGER**

Dette advarselssymbol betyder fare. Du befinder dig i en situation med risiko for legemeskade. Før du begynder arbejde på udstyr, skal du være opmærksom på de involverede risici, der er ved elektriske kredsløb, og du skal sætte dig ind i standardprocedurer til undgåelse af ulykker. Brug erklæringsnummeret efter hver advarsel for at finde oversættelsen i de oversatte advarsler, der fulgte med denne enhed.

GEM DISSE ANVISNINGER

تحذير

إرشادات الأمان الهامة

يوضح رمز التحذير هذا وجود خطر. وهذا يعني أنك متواجد في مكان قد ينتج عنه التعرض لإصابات. قبل بدء العمل، احذر مخاطر التعرض للصدمات الكهربائية وكن على علم بالإجراءات القياسية للحيلولة دون وقوع أي حوادث. استخدم رقم البيان الموجود في آخر كل تحذير لتحديد مكان ترجمته داخل تحذيرات الأمان المترجمة التي تأتي مع الجهاز. قم بحفظ هذه الإرشادات

Upozorenje VAŽNE SIGURNOSNE NAPOMENE

Ovaj simbol upozorenja predstavlja opasnost. Nalazite se u situaciji koja može prouzročiti tjelesne ozljede. Prije rada s bilo kojim uređajem, morate razumjeti opasnosti vezane uz električne sklopove, te biti upoznati sa standardnim načinima izbjegavanja nesreća. U prevedenim sigurnosnim upozorenjima, priloženima uz uređaj, možete prema broju koji se nalazi uz pojedino upozorenje pronaći i njegov prijevod.

SAČUVAJTE OVE UPUTE**Upozornění DŮLEŽITÉ BEZPEČNOSTNÍ POKYNY**

Tento upozorňující symbol označuje nebezpečí. Jste v situaci, která by mohla způsobit nebezpečí úrazu. Před prací na jakémkoliv vybavení si uvědomte nebezpečí související s elektrickými obvody a seznamte se se standardními opatřeními pro předcházení úrazům. Podle čísla na konci každého upozornění vyhledejte jeho překlad v přeložených bezpečnostních upozorněních, která jsou přiložena k zařízení.

USCHOVEJTE TYTO POKYNY

Προειδοποίηση	<p>ΣΗΜΑΝΤΙΚΕΣ ΟΔΗΓΙΕΣ ΑΣΦΑΛΕΙΑΣ</p> <p>Αυτό το προειδοποιητικό σύμβολο σημαίνει κίνδυνο. Βρίσκεστε σε κατάσταση που μπορεί να προκαλέσει τραυματισμό. Πριν εργαστείτε σε οποιοδήποτε εξοπλισμό, να έχετε υπόψη σας τους κινδύνους που σχετίζονται με τα ηλεκτρικά κυκλώματα και να έχετε εξοικειωθεί με τις συνηθισμένες πρακτικές για την αποφυγή ατυχημάτων. Χρησιμοποιήστε τον αριθμό δήλωσης που παρέχεται στο τέλος κάθε προειδοποίησης, για να εντοπίσετε τη μετάφρασή της στις μεταφρασμένες προειδοποιήσεις ασφαλείας που συνοδεύουν τη συσκευή.</p> <p>ΦΥΛΑΞΤΕ ΑΥΤΕΣ ΤΙΣ ΟΔΗΓΙΕΣ</p>
אזהרה	<p style="text-align: right;">הוראות בטיחות חשובות</p> <p>סימן אזהרה זה מסמל סכנה. אתה נמצא במצב העלול לגרום לפציעה. לפני שתעבוד עם ציוד כלשהו, עליך להיות מודע לסכנות הכרוכות במגעלים חשמליים ולהכיר את הנהלים המקובלים למניעת תאונות. השתמש במספר ההוראה המסופק בסופה של כל אזהרה כדי לאתר את התרגום באזהרות הבטיחות המתורגמות שמצורפות להתקן.</p> <p style="text-align: right;">שמור הוראות אלה</p>
Opomena	<p>ВАЖНИ БЕЗБЕДНОСНИ НАПАТСТВИЈА</p> <p>Симболот за предупредување значи опасност. Се наоѓате во ситуација што може да предизвика телесни повреди. Пред да работите со опремата, бидете свесни за ризикот што постои кај електричните кола и треба да ги познавате стандардните постапки за спречување на несреќни случаи. Искористете го бројот на изјавата што се наоѓа на крајот на секое предупредување за да го најдете неговиот период во преведените безбедносни предупредувања што се испорачани со уредот.</p> <p>ЧУВАЈТЕ ГИ ОБИЕ НАПАТСТВИЈА</p>
Ostrzeżenie	<p>WAŻNE INSTRUKCJE DOTYCZĄCE BEZPIECZEŃSTWA</p> <p>Ten symbol ostrzeżenia oznacza niebezpieczeństwo. Zachodzi sytuacja, która może powodować obrażenia ciała. Przed przystąpieniem do prac przy urządzeniach należy zapoznać się z zagrożeniami związanymi z układami elektrycznymi oraz ze standardowymi środkami zapobiegania wypadkom. Na końcu każdego ostrzeżenia podano numer, na podstawie którego można odszukać tłumaczenie tego ostrzeżenia w dołączonym do urządzenia dokumencie z tłumaczeniami ostrzeżeń.</p> <p>NINIEJSZE INSTRUKCJE NALEŻY ZACHOWAĆ</p>
Upozornenie	<p>DÔLEŽITÉ BEZPEČNOSTNÉ POKYNY</p> <p>Tento varovný symbol označuje nebezpečenstvo. Nachádzate sa v situácii s nebezpečenstvom úrazu. Pred prácou na akomkoľvek vybavení si uvedomte nebezpečenstvo súvisiace s elektrickými obvodmi a oboznámte sa so štandardnými opatreniami na predchádzanie úrazom. Podľa čísla na konci každého upozornenia vyhľadajte jeho preklad v preložených bezpečnostných upozorneniach, ktoré sú priložené k zariadeniu.</p> <p>USCHOVAJTE SI TENTO NÁVOD</p>

Obtaining Optical Networking Information

This section contains information that is specific to optical networking products. For information that pertains to all of Cisco, refer to the [Obtaining Documentation and Submitting a Service Request](#) section.

Where to Find Safety and Warning Information

For safety and warning information, refer to the *Cisco Optical Transport Products Safety and Compliance Information* document that accompanied the product. This publication describes the international agency compliance and safety information for the Cisco ONS 15454 system. It also includes translations of the safety warnings that appear in the ONS 15454 system documentation.

Cisco Optical Networking Product Documentation CD-ROM

Optical networking-related documentation, including Cisco ONS 15xxx product documentation, is available in a CD-ROM package that ships with your product. The Optical Networking Product Documentation CD-ROM is updated periodically and may be more current than printed documentation.

Obtaining Documentation and Submitting a Service Request

For information on obtaining documentation, submitting a service request, and gathering additional information, see the monthly *What's New in Cisco Product Documentation*, which also lists all new and revised Cisco technical documentation, at:

<http://www.cisco.com/en/US/docs/general/whatsnew/whatsnew.html>

Subscribe to the *What's New in Cisco Product Documentation* as a Really Simple Syndication (RSS) feed and set content to be delivered directly to your desktop using a reader application. The RSS feeds are a free service and Cisco currently supports RSS Version 2.0.



CHAPTER 1

Shelf and Backplane Hardware



Note

The terms "Unidirectional Path Switched Ring" and "UPSR" may appear in Cisco literature. These terms do not refer to using Cisco ONS 15xxx products in a unidirectional path switched ring configuration. Rather, these terms, as well as "Path Protected Mesh Network" and "PPMN," refer generally to Cisco's path protection feature, which may be used in any topological network configuration. Cisco does not recommend using its path protection feature in any particular topological network configuration.

This chapter provides a description of Cisco ONS 15454 shelf and backplane hardware. Card descriptions are provided in [Chapter 2, "Common Control Cards,"](#) [Chapter 3, "Electrical Cards,"](#) [Chapter 4, "Optical Cards,"](#) [Chapter 5, "Ethernet Cards,"](#) and [Chapter 6, "Storage Access Networking Cards."](#) To install equipment, refer to the *Cisco ONS 15454 Procedure Guide*.

Chapter topics include:

- [1.1 Overview, page 1-2](#)
- [1.2 Rack Installation, page 1-3](#)
- [1.3 Front Door, page 1-6](#)
- [1.4 Backplane Covers, page 1-10](#)
- [1.5 Electrical Interface Assemblies, page 1-14](#)
- [1.6 Coaxial Cable, page 1-37](#)
- [1.7 DS-1 Cable, page 1-37](#)
- [1.8 UBIC-V Cables, page 1-39](#)
- [1.9 UBIC-H Cables, page 1-44](#)
- [1.11 Cable Routing and Management, page 1-52](#)
- [1.12 Alarm Expansion Panel, page 1-55](#)
- [1.13 Filler Card, page 1-60](#)
- [1.14 Fan-Tray Assembly, page 1-61](#)
- [1.15 Power and Ground Description, page 1-63](#)
- [1.16 Alarm, Timing, LAN, and Craft Pin Connections, page 1-64](#)
- [1.17 Cards and Slots, page 1-68](#)
- [1.18 Software and Hardware Compatibility, page 1-73](#)

**Caution**

Unused card slots should be filled with a detectable filler card (Cisco P/N 15454-FILLER) or a non-detectable filler card (Cisco P/N 15454-BLANK). The filler card ensures proper airflow when operating the ONS 15454 without the front door attached, although Cisco recommends that the front door remain attached.

**Note**

The ONS 15454 is designed to comply with Telcordia GR-1089-CORE Type 2 and Type 4. Install and operate the ONS 15454 only in environments that do not expose wiring or cabling to the outside plant. Acceptable applications include Central Office Environments (COEs), Electronic Equipment Enclosures (EEEs), Controlled Environment Vaults (CEVs), huts, and Customer Premise Environments (CPEs).

**Note**

The Cisco ONS 15454 assembly is intended for use with telecommunications equipment only.

**Note**

You can search for cross-referenced Cisco part numbers and CLEI (Common Language Equipment Identification) codes at the following link: http://www.cisco.com/cgi-bin/front.x/clei/code_search.cgi.

1.1 Overview

When installed in an equipment rack, the ONS 15454 assembly is typically connected to a fuse and alarm panel to provide centralized alarm connection points and distributed power for the ONS 15454. Fuse and alarm panels are third-party equipment and are not described in this documentation. If you are unsure about the requirements or specifications for a fuse and alarm panel, consult the user documentation for the related equipment. The front door of the ONS 15454 allows access to the shelf assembly, fan-tray assembly, and cable-management area. The backplanes provide access to alarm contacts, external interface contacts, power terminals, and BNC/SMB connectors.

You can mount the ONS 15454 in a 19- or 23-inch rack (482.6 or 584.2 mm). The shelf assembly weighs approximately 55 pounds (24.94 kg) with no cards installed. The shelf assembly includes a front door for added security, a fan tray module for cooling, and extensive cable-management space.

ONS 15454 optical cards have SC and LC connectors on the card faceplate. Fiber-optic cables are routed into the front of the destination cards. Electrical cards (DS-1, DS-3, DS3XM, and EC-1) require electrical interface assemblies (EIAs) to provide the cable connection points for the shelf assembly. In most cases, EIAs are ordered with the ONS 15454 and come preinstalled on the backplane. See the [“1.5 Electrical Interface Assemblies” section on page 1-14](#) for more information about the EIAs.

The ONS 15454 is powered using –48 VDC power. Negative, return, and ground power terminals are accessible on the backplane.

**Note**

In this chapter, the terms “ONS 15454” and “shelf assembly” are used interchangeably. In the installation context, these terms have the same meaning. Otherwise, shelf assembly refers to the physical steel enclosure that holds cards and connects power, and ONS 15454 refers to the entire system, both hardware and software.

Install the ONS 15454 in compliance with your local and national electrical codes:

- United States: National Fire Protection Association (NFPA) 70; United States National Electrical Code
- Canada: Canadian Electrical Code, Part I, CSA C22.1
- Other countries: If local and national electrical codes are not available refer to IEC 364, Part 1 through Part 7

1.2 Rack Installation

The ONS 15454 is mounted in a 19- or 23-in. (482.6- or 584.2-mm) equipment rack. The shelf assembly projects five inches (127 mm) from the front of the rack. It mounts in both Electronic Industries Alliance (EIA) standard and Telcordia-standard racks. The shelf assembly is a total of 17 inches (431.8 mm) wide with no mounting ears attached. Ring runs are not provided by Cisco and might hinder side-by-side installation of shelves where space is limited.

The ONS 15454 measures 18.5 inches (469.9 mm) high, 19 or 23 inches (482.6 or 584.2 mm) wide (depending on which way the mounting ears are attached), and 12 inches (304.8 mm) deep. You can install up to four ONS 15454 shelves in a seven-foot (2133.6 mm) equipment rack. The ONS 15454 must have one inch (25.4 mm) of airspace below the installed shelf assembly to allow air flow to the fan intake. If a second ONS 15454 is installed underneath the shelf assembly, the air ramp on top of the lower shelf assembly provides the air spacing needed and should not be modified in any way. [Figure 1-1](#) shows the dimensions of the ONS 15454.



Note

A 10-Gbps-compatible shelf assembly (15454-SA-ANSI or 15454-SA-HD) and fan-tray assembly (15454-FTA3 or 15454-FTA3-T) are required if ONS 15454 XC10G and ONS 15454 XC-VXC-10G cards are installed in the shelf.

Figure 1-1 Cisco ONS 15454 ANSI Dimensions

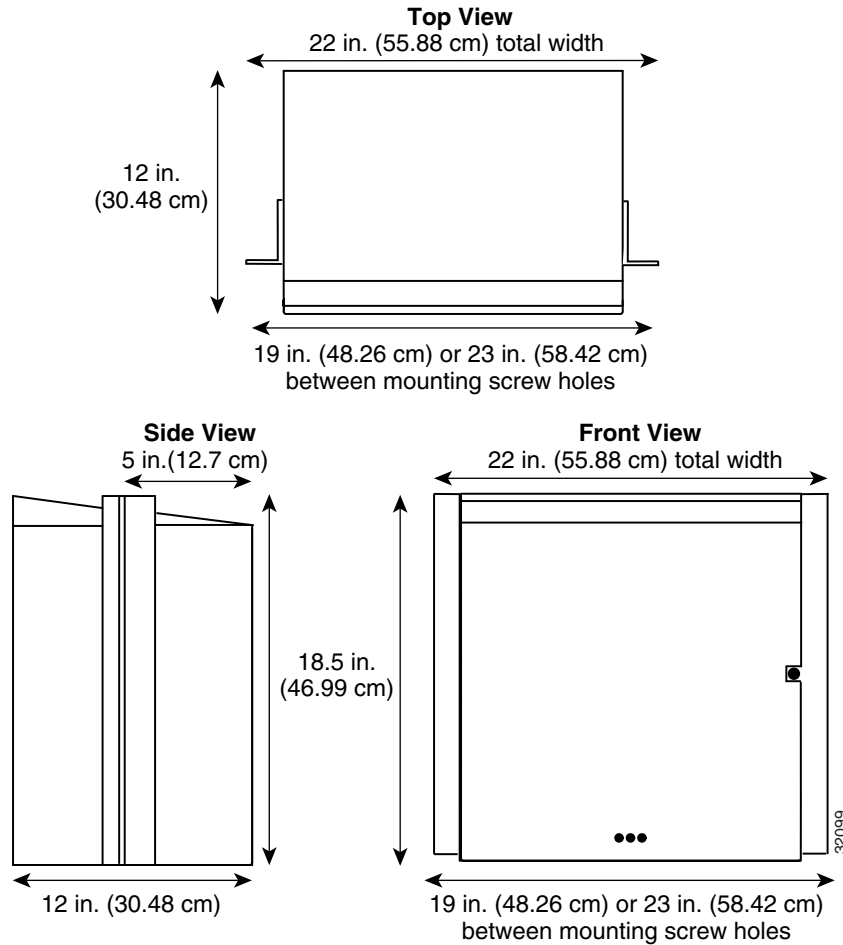

1.2.1 Reversible Mounting Bracket



Caution

Use only the fastening hardware provided with the ONS 15454 to prevent loosening, deterioration, and electromechanical corrosion of the hardware and joined material.



Caution

When mounting the ONS 15454 in a frame with a nonconductive coating (such as paint, lacquer, or enamel) either use the thread-forming screws provided with the ONS 15454 shipping kit, or remove the coating from the threads to ensure electrical continuity.

The shelf assembly comes preset for installation in a 23-inch (584.2 mm) rack, but you can reverse the mounting bracket to fit the smaller 19-inch (482.6 mm) rack.

1.2.2 Mounting a Single Node

Mounting the ONS 15454 in a rack requires a minimum of 18.5 inches (469.9 mm) of vertical rack space and one additional inch (25.4 mm) for air flow. To ensure the mounting is secure, use two to four #12-24 mounting screws for each side of the shelf assembly. [Figure 1-2](#) shows the rack mounting position for the ONS 15454.

Figure 1-2 Mounting an ONS 15454 in a Rack

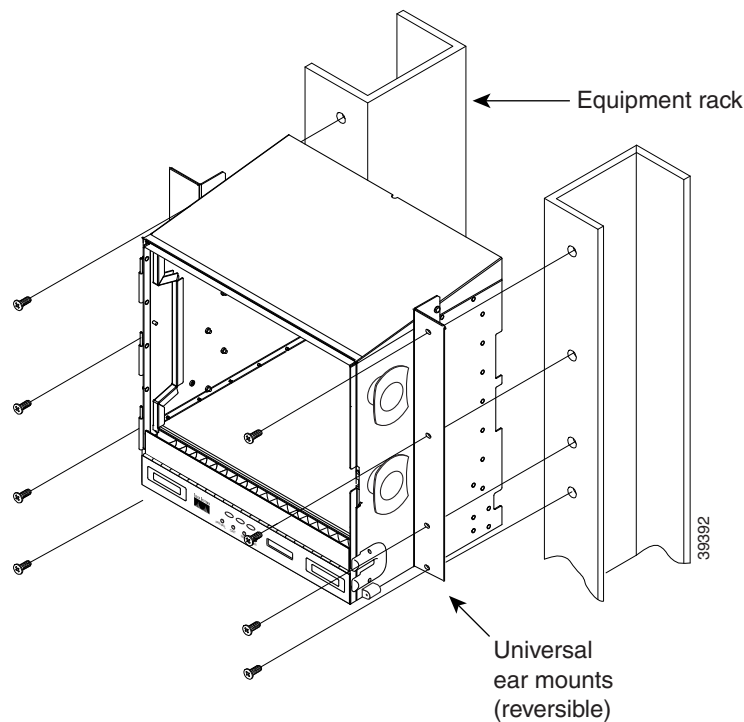

Two people should install the shelf assembly; however, one person can install it using the temporary set screws included. The shelf assembly should be empty for easier lifting. The front door can also be removed to lighten the shelf assembly.

If you are installing the fan-tray air filter using the bottom (external) brackets provided, mount the brackets on the bottom of the shelf assembly before installing the ONS 15454 in a rack.

1.2.3 Mounting Multiple Nodes

Most standard (Telcordia GR-63-CORE, 19-inch [482.6 mm] or 23-inch [584.2 mm]) seven-foot (2,133 mm) racks can hold four ONS 15454 shelves and a fuse and alarm panel. However, unequal flange racks are limited to three ONS 15454 shelves and a fuse and alarm panel or four ONS 15454 shelves and a fuse and alarm panel from an adjacent rack.

If you are using the external (bottom) brackets to install the fan-tray air filter, you can install three shelf assemblies in a standard seven-foot (2.133 m) rack. If you are not using the external (bottom) brackets, you can install four shelf assemblies in a rack. The advantage to using the bottom brackets is that you can replace the filter without removing the fan tray.

1.2.4 ONS 15454 Bay Assembly

The Cisco ONS 15454 bay assembly simplifies ordering and installing the ONS 15454 because it allows you to order shelf assemblies preinstalled in a seven-foot (2.133 m) rack. The bay assembly is available in a three- or four-shelf configuration. The three-shelf configuration includes three ONS 15454 shelf assemblies, a prewired fuse and alarm panel, and two cable-management trays. The four-shelf configuration includes four ONS 15454 shelf assemblies and a prewired fuse and alarm panel. You can order optional fiber channels with either configuration. Installation procedures are included in the *Unpacking and Installing the Cisco ONS 15454 Four-Shelf and Zero-Shelf Bay Assembly* document that ships with the Bay Assembly,

1.3 Front Door

The Critical, Major, and Minor alarm LEDs visible through the front door indicate whether a critical, major, or minor alarm is present anywhere on the ONS 15454. These LEDs must be visible so technicians can quickly determine if any alarms are present on the ONS 15454 shelf or the network. You can use the LCD to further isolate alarms. The front door (Figure 1-3) provides access to the shelf assembly, cable-management tray, fan-tray assembly, and LCD screen.

Figure 1-3 The ONS 15454 Front Door

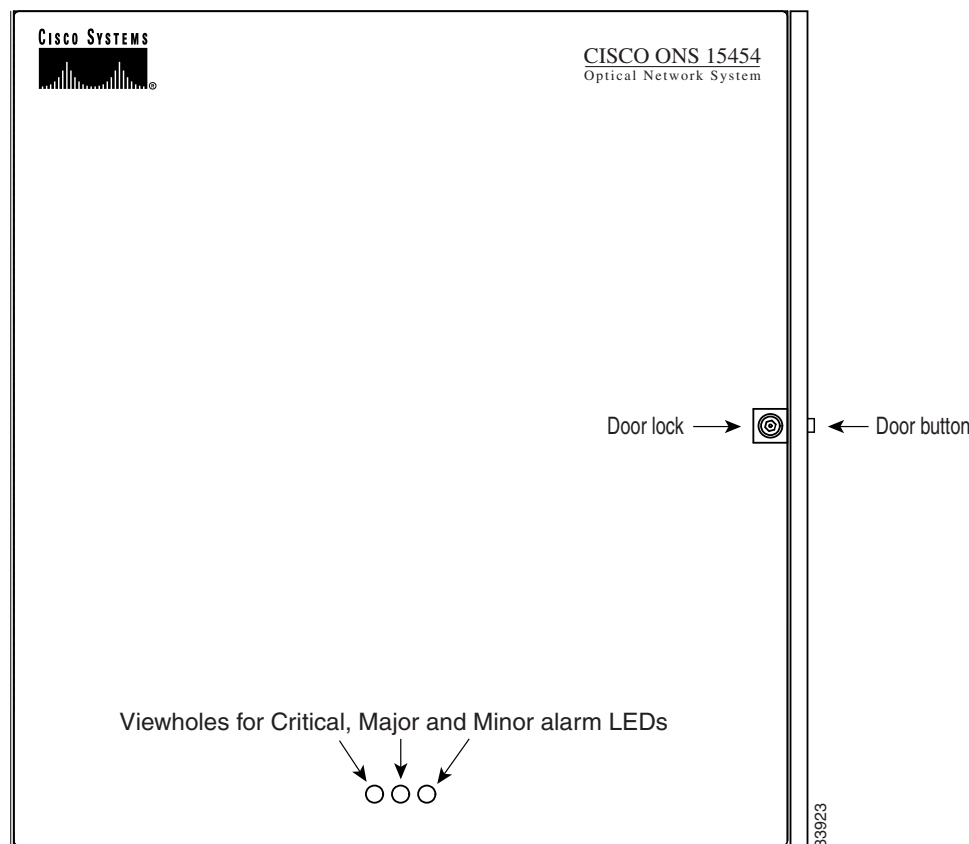

The ONS 15454 ships with a standard door but can also accommodate a deep door and extended fiber clips (15454-DOOR-KIT) to provide additional room for cabling (Figure 1-4).

Figure 1-4 Cisco ONS 15454 Deep Door

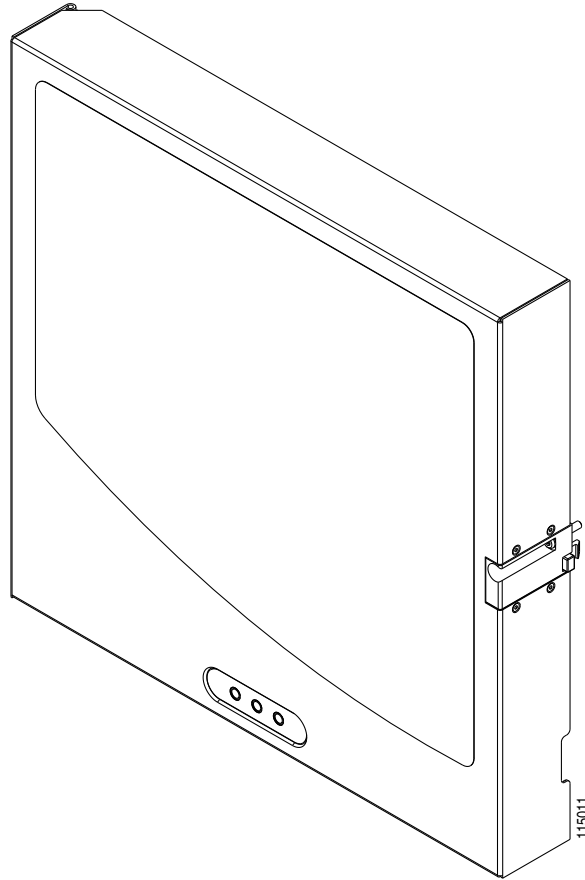

The ONS 15454 door locks with a pinned hex key that ships with the ONS 15454. A button on the right side of the shelf assembly releases the door. You can remove the front door of the ONS 15454 to provide unrestricted access to the front of the shelf assembly. Before you remove the front door, you have to remove the ground strap of the front door ([Figure 1-5](#)).

Figure 1-5 ONS 15454 Front Door Ground Strap

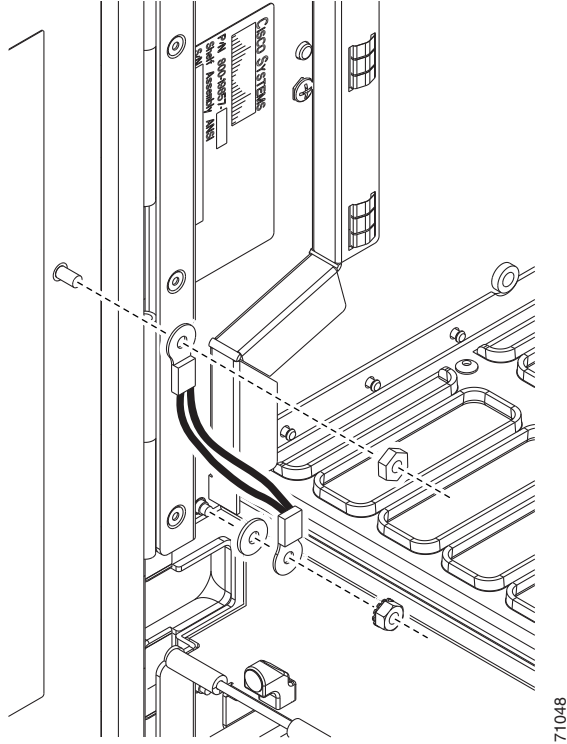
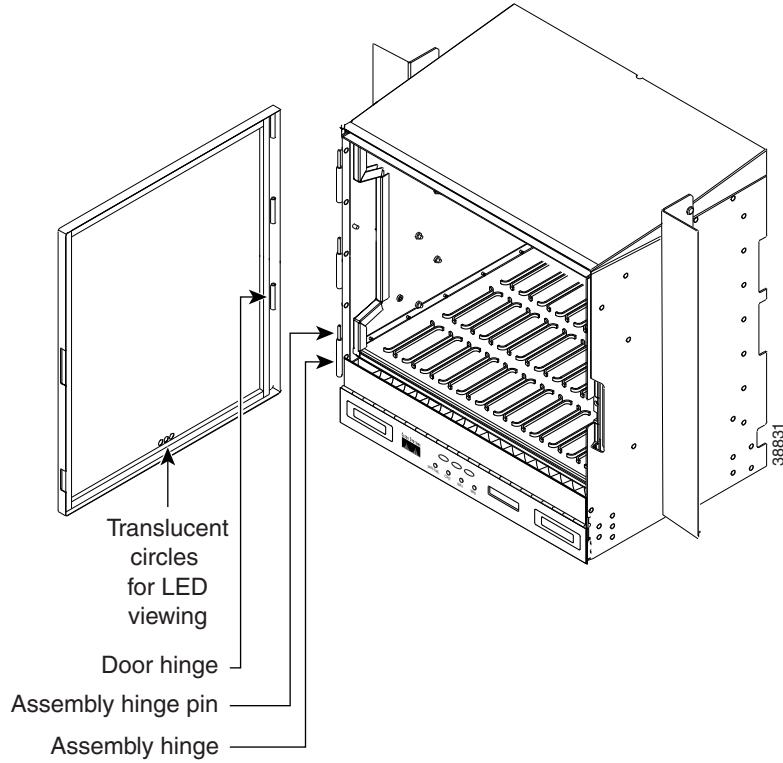

Figure 1-6 shows how to remove the front door.

Figure 1-6 Removing the ONS 15454 Front Door



An erasable label is pasted on the inside of the front door (Figure 1-7). You can use the label to record slot assignments, port assignments, card types, node ID, rack ID, and serial number for the ONS 15454.

Figure 1-7 Front-Door Erasable Label

		SLOT ASSIGNMENTS																
CARD NAME		1	2	3	4	5	6	7	8	9	10	11	12	13	14	15	16	17
P O R T A S S I G N M E N T S	1							TCC ___	XC ___	---	XC ___	TCC ___						
	2																	
	3																	
	4																	
	5																	
	6																	
	7																	
	8																	
	9																	
	10																	
	11																	
	12																	
	13																	
	14																	
	15																	
	16																	

SHELF ID:	 DANGER INVISIBLE RADIATION MAY BE EMITTED FROM OPTICAL CARDS AT THE END OF UNTERMINATED FIBER CABLES OR CONNECTORS. DO NOT STARE INTO THE BEAM OR VIEW DIRECTLY WITH OPTICAL INSTRUMENTS. CLASS I - LASER PRODUCT (CDRH) CLASS 1M LASER PRODUCT (IEC)	ATTN: TO MAINTAIN FCC EMI COMPLIANCE REPLACE FRONT COVER AFTER SERVICING.	IP ADDRESS:
RACK ID:			MAC ADDRESS:
SERIAL #:			CAUTION: ELECTROSTATIC SENSITIVE DEVICES PRODUCT COMPLIES WITH RADIATION PERFORMANCE STANDARDS 21CFR 1040.10 AND 1040.11, IEC 60825-1 AND IEC 60825-2.

61840

**Note**

The front door label also includes the Class I and Class 1M laser warning (Figure 1-8).

Figure 1-8 Laser Warning on the Front-Door Label

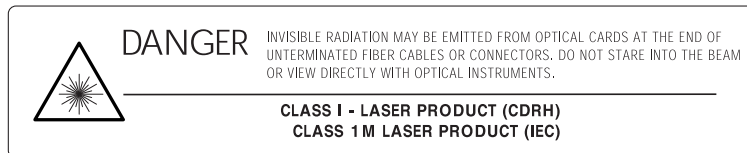

67575

1.4 Backplane Covers

If a backplane does not have an EIA panel installed, it should have two sheet metal backplane covers (one on each side of the backplane) as shown in Figure 1-9 on page 1-11. Each cover is held in place with nine 6-32 x 3/8 inch Phillips screws.

**Note**

See the “1.5 Electrical Interface Assemblies” section on page 1-14 for information on EIAs.

Figure 1-9 Backplane Covers

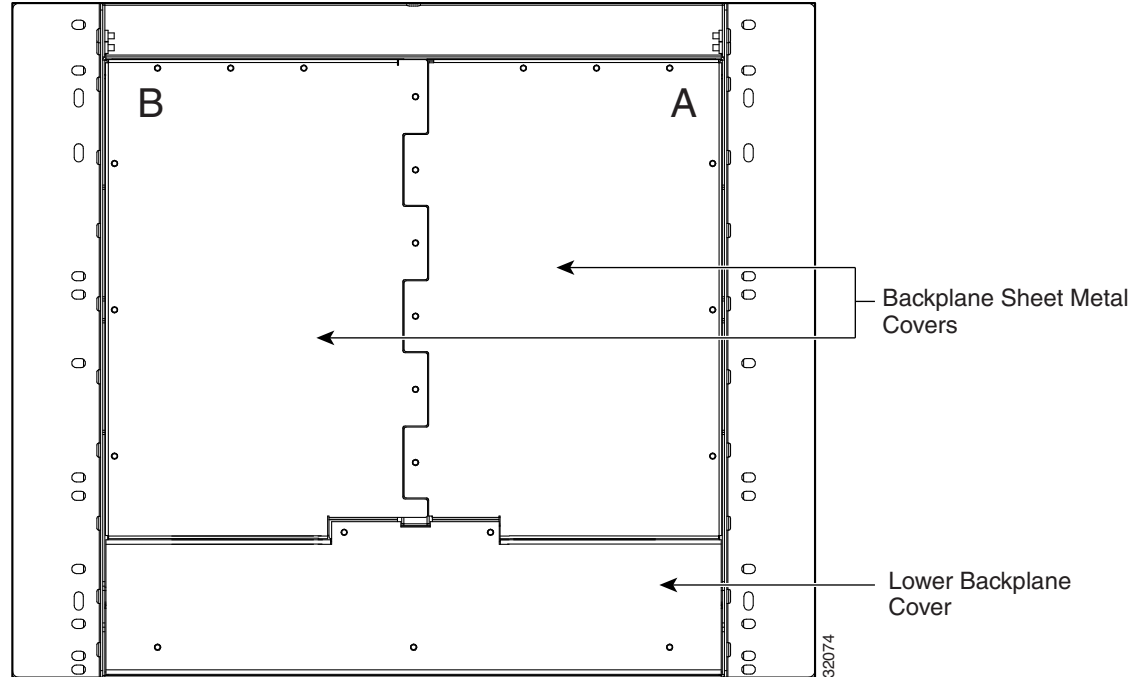

1.4.1 Lower Backplane Cover

The lower section of the ONS 15454 backplane is covered by either a clear plastic protector (15454-SA-ANSI) or a sheet metal cover (15454-SA-HD), which is held in place by five 6-32 x 1/2 inch screws. Remove the lower backplane cover to access the alarm interface panel (AIP), alarm pin fields, frame ground, and power terminals (Figure 1-10).

Figure 1-10 Removing the Lower Backplane Cover

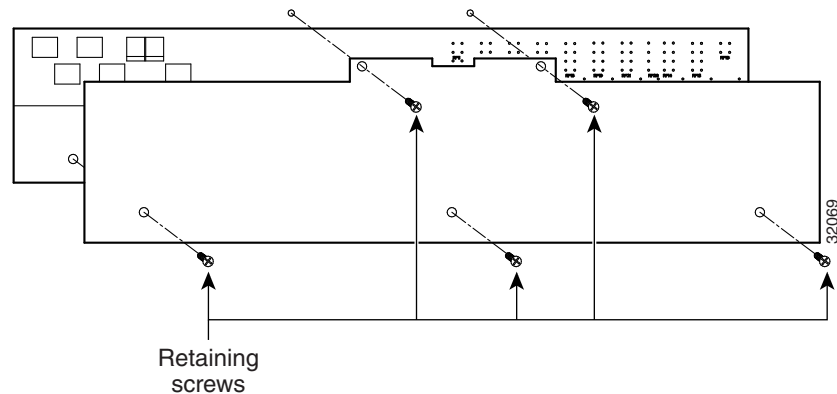

1.4.2 Rear Cover

The ONS 15454 has an optional clear plastic rear cover. This clear plastic cover provides additional protection for the cables and connectors on the backplane. [Figure 1-11](#) shows the rear cover screw locations.

Figure 1-11 Backplane Attachment for Cover

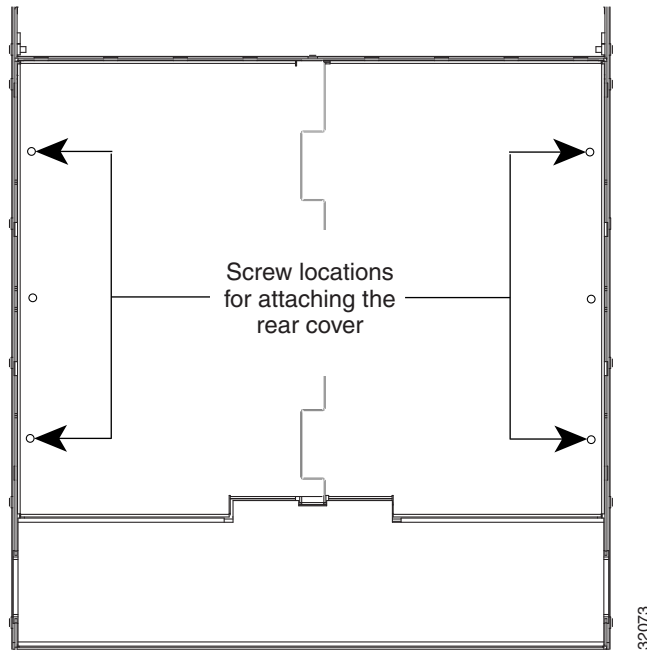

You can also install the optional spacers if more space is needed between the cables and rear cover ([Figure 1-12](#)).

Figure 1-12 *Installing the Plastic Rear Cover with Spacers*

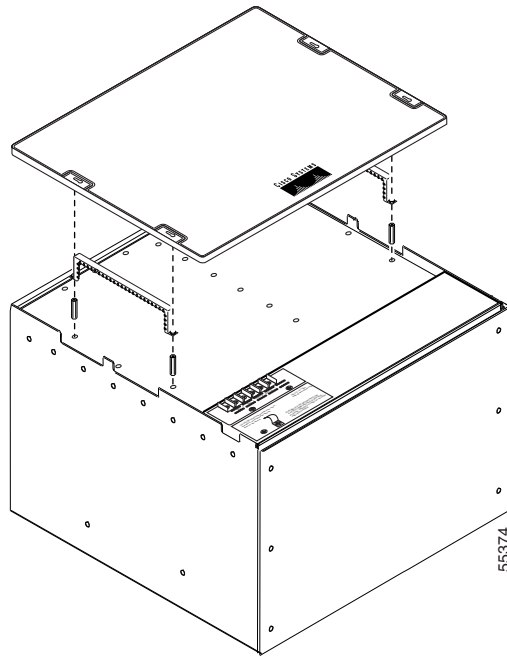

1.4.3 Alarm Interface Panel

The AIP is located above the alarm contacts on the lower section of the backplane. The AIP provides surge protection for the ONS 15454. It also provides an interface from the backplane to the fan-tray assembly and LCD. The AIP plugs into the backplane using a 96-pin DIN connector and is held in place with two retaining screws. The panel has a nonvolatile memory chip that stores the unique node address (MAC address).



Note

The MAC address identifies the nodes that support circuits. It allows Cisco Transport Controller (CTC) to determine circuit sources, destinations, and spans. The TCC2/TCC2P cards in the ONS 15454 also use the MAC address to store the node database.

The 5-A AIP (73-7665-XX) is required when installing the new fan-tray assembly (15454-FTA3), which comes preinstalled on the shelf assembly (15454-SA-ANSI or 15454-SA-HD).



Note

A blown fuse on the AIP board can cause the LCD display to go blank.

1.4.4 Alarm Interface Panel Replacement

If the alarm interface panel (AIP) fails, a MAC Fail alarm appears on the CTC Alarms menu and/or the LCD display on the fan-tray assembly goes blank. To perform an in-service replacement of the AIP, you must contact Cisco Technical Assistance Center (TAC). For contact information, go to the TAC website at <http://www.cisco.com/tac>.

You can replace the AIP on an in-service system without affecting traffic (except Ethernet traffic on nodes running a software release earlier than Release 4.0). The circuit repair feature allows you to repair circuits affected by MAC address changes on one node at a time. Circuit repair works when all nodes are running the same software version. Each individual AIP upgrade requires an individual circuit repair; if AIPs are replaced on two nodes, the circuit repair must be performed twice.

**Caution**

Do not use a 2-A AIP with a 5-A fan-tray assembly; doing so causes a blown fuse on the AIP.

**Note**

Ensure that all nodes in the affected network are running the same software version before replacing the AIP and repairing circuits. If you need to upgrade nodes to the same software version, do not change any hardware or repair circuits until after the software upgrade is complete. Replace an AIP during a maintenance window. Resetting the active TCC2/TCC2P card can cause a service disruption of less than 50 ms to optical or electrical traffic. Resetting the active TCC2/TCC2P card causes a service disruption of three to five minutes on all E-Series Ethernet traffic due to spanning tree reconvergence. Refer to the *Cisco ONS 15454 Troubleshooting Guide* for an AIP replacement procedure.

1.5 Electrical Interface Assemblies

Optional EIA backplane covers are typically preinstalled when ordered with the ONS 15454. EIAs must be ordered when using DS-1, DS-3, DS3XM, or EC-1 cards. This section describes each EIA.

Six different EIA backplane covers are available for the ONS 15454: BNC, High-Density BNC, MiniBNC, SMB, AMP Champ, UBIC-H (Universal Backplane Interface Connector-Horizontal), and UBIC-V (Vertical). If the shelf was not shipped with the correct EIA interface, you must order and install the correct EIA.

EIAs are attached to the shelf assembly backplane to provide electrical interface cable connections. EIAs are available with SMB and BNC connectors for DS-3 or EC-1 cards. EIAs are available with AMP Champ connectors for DS-1 cards. You must use SMB EIAs for DS-1 twisted-pair cable installation. UBIC-V EIAs have SCSI connectors. They are available for use with any DS-1, DS-3, or EC-1 card, but are intended for use with high-density electrical cards.

**Note**

The MiniBNC EIAs only support cables using the Trompetor connectors for termination.

You can install EIAs on one or both sides of the ONS 15454 backplane in any combination (in other words, AMP Champ on Side A and BNC on Side B or High-Density BNC on Side A and SMB on Side B, and so forth). As you face the rear of the ONS 15454 shelf assembly, the right side is the A side and the left side is the B side. The top of the EIA connector columns are labeled with the corresponding slot number, and EIA connector pairs are marked transmit (Tx) and receive (Rx) to correspond to transmit and receive cables.

**Note**

For information about EIA types, protection schemes, and card slots, see [Chapter 7, “Card Protection.”](#)

1.5.1 EIA Installation

Optional EIA backplane covers are typically preinstalled when ordered with the ONS 15454. A minimal amount of assembly might be required when EIAs are ordered separately from the ONS 15454. If you are installing EIAs after the shelf assembly is installed, plug the EIA into the backplane. The EIA has six electrical connectors that plug into six corresponding backplane connectors. The EIA backplane must replace the standard sheet metal cover to provide access to the coaxial cable connectors. The EIA sheet metal covers use the same screw holes as the solid backplane panels, but they have 12 additional 6-32 x 1/2 inch Phillips screw holes so you can screw down the cover and the board using standoffs on the EIA board.

When using the RG-179 coaxial cable on an EIA, the maximum distance available (122 feet [37 meters]) is less than the maximum distance available with standard RG-59 (734A) cable (306 feet [93 meters]). The maximum distance when using the RG-59 (734A) cable is 450 feet (137 meters). The shorter maximum distance available with the RG179 is due to a higher attenuation rate for the thinner cable. Attenuation rates are calculated using a DS-3 signal:

- For RG-179, the attenuation rate is 59 dB/kft at 22 MHz.
- For RG-59 (734A) the attenuation rate is 11.6 dB/kft at 22 MHz.

1.5.2 EIA Configurations

Table 1-1 shows the EIA types supported only by ONS 15454 shelf assembly 15454-SA-ANSI.

Table 1-1 EIA Types Compatible with the 15454-SA-ANSI Only

EIA Type	Cards Supported	A-Side Hosts	A-Side Columns Map to	A-Side Product Number	B-Side Hosts	B-Side Columns Map to	B-Side Product Number
BNC	DS-3 DS3XM-6 EC-1	24 pairs of BNC connectors	Slot 2 Slot 4	15454-EIA-BNC-A24=	24 pairs of BNC connectors	Slot 14 Slot 16	15454-EIA-BNC-B24=
High-Density BNC	DS-3 DS3XM-6 EC-1	48 pairs of BNC connectors	Slot 1 Slot 2 Slot 4 Slot 5	15454-EIA-BNC-A48=	48 pairs of BNC connectors	Slot 13 Slot 14 Slot 16 Slot 17	15454-EIA-BNC-B48=

Table 1-1 EIA Types Compatible with the 15454-SA-ANSI Only (continued)

EIA Type	Cards Supported	A-Side Hosts	A-Side Columns Map to	A-Side Product Number	B-Side Hosts	B-Side Columns Map to	B-Side Product Number
SMB	DS-1 DS-3 EC-1 DS3XM-6	84 pairs of SMB connectors	Slot 1 Slot 2 Slot 3 Slot 4 Slot 5 Slot 6	15454-EIA-SMB-A84=	84 pairs of SMB connectors	Slot 12 Slot 13 Slot 14 Slot 15 Slot 16 Slot 17	15454-EIA-SMB-B84=
AMP Champ	DS-1	6 AMP Champ connectors	Slot 1 Slot 2 Slot 3 Slot 4 Slot 5 Slot 6	15454-EIA-AMP-A84=	6 AMP Champ connectors	Slot 12 Slot 13 Slot 14 Slot 15 Slot 16 Slot 17	15454-EIA-AMP-B84=

Table 1-2 shows the EIA types supported by both the 15454-SA-ANSI and the 15454-SA-HD (high density) shelf assemblies.

Table 1-2 EIA Configurations Compatible with the 15454-SA-ANSI and the 15454-SA-HD

EIA Type	Cards Supported	A-Side Hosts	A-Side Columns Map to	A-Side Product Number	B-Side Hosts	B-Side Columns Map to	B-Side Product Number
BNC	DS-3 DS3XM-6 DS3XM-12 EC-1	24 pairs of BNC connectors	Slot 2 Slot 4	15454-EIA-1BNCA24=	24 pairs of BNC connectors	Slot 14 Slot 16	15454-EIA-1BNCB24=
High-Density BNC	DS-3 DS3XM-6 DS3XM-12 EC-1	48 pairs of BNC connectors	Slot 1 Slot 2 Slot 4 Slot 5	15454-EIA-1BNCA48=	48 pairs of BNC connectors	Slot 13 Slot 14 Slot 16 Slot 17	15454-EIA-1BNCB48=
Mini BNC	DS-3 DS-3/EC1-48 DS3XM-6 DS3XM-12 EC-1	96 pairs of MiniBNC connectors	Slot 1 Slot 2 Slot 4 Slot 5 Slot 6	15454-EIA-BNC-A96=	96 pairs of MiniBNC connectors	Slot 12 Slot 13 Slot 14 Slot 16 Slot 17	15454-EIA-BNC-A96=

Table 1-2 EIA Configurations Compatible with the 15454-SA-ANSI and the 15454-SA-HD (continued)

EIA Type	Cards Supported	A-Side Hosts	A-Side Columns Map to	A-Side Product Number	B-Side Hosts	B-Side Columns Map to	B-Side Product Number
SMB	DS-1 DS-3 EC-1 DS3XM-6 DS3XM-12	84 pairs of SMB connectors	Slot 1 Slot 2 Slot 3 Slot 4 Slot 5 Slot 6	15454-EIA-1SMBA84=	84 pairs of SMB connectors	Slot 12 Slot 13 Slot 14 Slot 15 Slot 16 Slot 17	15454-EIA-1SMBB84=
AMP Champ	DS-1	6 AMP Champ connectors	Slot 1 Slot 2 Slot 3 Slot 4 Slot 5 Slot 6	15454-EIA-1AMPA84=	6 AMP Champ connectors	Slot 12 Slot 13 Slot 14 Slot 15 Slot 16 Slot 17	15454-EIA-1AMPB84=
UBIC-V	DS-1 DS-3 EC-1 DS3XM-6 DS3XM-12 DS3/EC1-48 DS1/E1-56	8 pairs of SCSI connectors	Slot 1 Slot 2 Slot 3 Slot 4 Slot 5 Slot 6	15454-EIA-UBICV-A	8 pairs of SCSI connectors	Slot 12 Slot 13 Slot 14 Slot 15 Slot 16 Slot 17	15454-EIA-UBICV-B
UBIC-H	DS-1 DS-3 EC-1 DS3XM-6 DS3XM-12 DS3/EC1-48 DS1/E1-56	8 pairs of SCSI connectors	Slot 1 Slot 2 Slot 3 Slot 4 Slot 5 Slot 6	15454-EIA-UBICH-A	8 pairs of SCSI connectors	Slot 12 Slot 13 Slot 14 Slot 15 Slot 16 Slot 17	15454-EIA-UBICH-B

1.5.3 BNC EIA

The ONS 15454 BNC EIA supports 24 DS-3 circuits on each side of the ONS 15454 (24 transmit and 24 receive connectors). If you install BNC EIAs on both sides of the shelf assembly, the ONS 15454 hosts up to 48 circuits. The BNC connectors on the EIA supports Trompeter UCBJ224 (75-ohm) 4-leg connectors (King or ITT are also compatible). Right-angle mating connectors for the connecting cable are AMP 413588-2 (75-ohm) connectors. If preferred, you can also use a straight connector of the same

type. Use RG-59/U cable to connect to the ONS 15454 BNC EIA. These cables are recommended to connect to a patch panel and are designed for long runs. You can use BNC EIAs for DS-3 (including the DS3XM-6 and DS3XM-12) or EC-1 cards.

Figure 1-13 shows the ONS 15454 with preinstalled BNC EIAs.

To install coaxial cable with BNC connectors, refer to the “Install Shelf and Backplane Hardware” chapter in the *Cisco ONS 15454 Procedure Guide*.

Figure 1-13 BNC Backplane for Use in 1:1 Protection Schemes

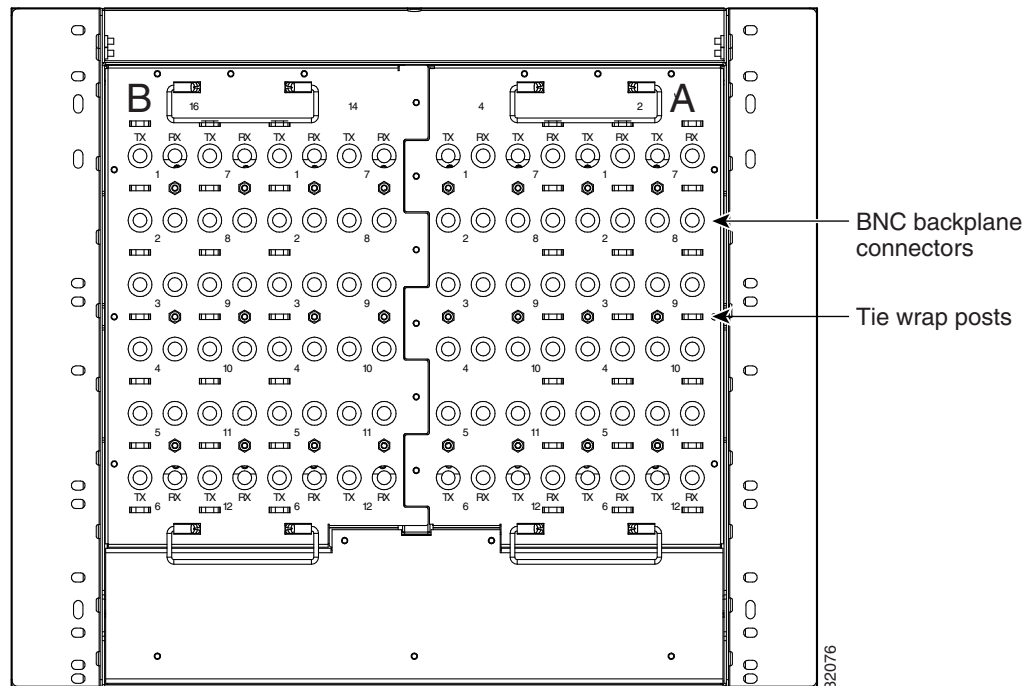

1.5.3.1 BNC Connectors

The EIA side marked “A” has 24 pairs of BNC connectors. The first 12 pairs of BNC connectors correspond to Ports 1 to 12 for a 12-port card and map to Slot 2 on the shelf assembly. The BNC connector pairs are marked “Tx” and “Rx” to indicate transmit and receive cables for each port. You can install an additional card in Slot 1 as a protect card for the card in Slot 2. The second 12 BNC connector pairs correspond to Ports 1 to 12 for a 12-port card and map to Slot 4 on the shelf assembly. You can install an additional card in Slot 3 as a protect card for the card in Slot 4. Slots 5 and 6 do not support DS-3 cards when the standard BNC EIA panel connectors are used.

The EIA side marked “B” provides an additional 24 pairs of BNC connectors. The first 12 BNC connector pairs correspond to Ports 1 to 12 for a 12-port card and map to Slot 14 on the shelf assembly. The BNC connector pairs are marked “Tx” and “Rx” to indicate transmit and receive cables for each port. You can install an additional card in Slot 15 as a protect card for the card in Slot 14. The second 12 BNC connector pairs correspond to Ports 1 to 12 for a 12-port card and map to Slot 16 on the shelf assembly. You can install an additional card in Slot 17 as a protect card for the card in Slot 16. Slots 12 and 13 do not support DS-3 cards when the standard BNC EIA panel connectors are used.

When BNC connectors are used with a DS3N-12 card in Slot 3 or 15, the 1:N card protection extends only to the two slots adjacent to the 1:N card due to BNC wiring constraints.

1.5.3.2 BNC Insertion and Removal Tool

Due to the large number of BNC connectors on the high-density BNC EIA, you might require a special tool for inserting and removing BNC EIAs (Figure 1-14). This tool also helps with ONS 15454 patch panel connections.

Figure 1-14 BNC Insertion and Removal Tool

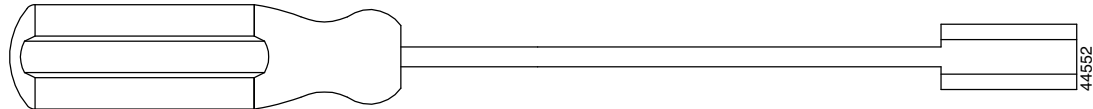

This tool can be obtained with P/N 227-T1000 from:

Amphenol USA (www.amphenol.com)
One Kennedy Drive
Danbury, CT 06810
Phone: 203 743-9272 Fax: 203 796-2032

This tool can be obtained with P/N RT-1L from:

Trompeter Electronics Inc. (www.trompeter.com)
31186 La Baya Drive
Westlake Village, CA 91362-4047
Phone: 800 982-2629 Fax: 818 706-1040

1.5.4 High-Density BNC EIA

The ONS 15454 high-density BNC EIA supports 48 DS-3 circuits on each side of the ONS 15454 (48 transmit and 48 receive connectors). If you install BNC EIAs on both sides of the unit, the ONS 15454 hosts up to 96 circuits. The high-density BNC EIA supports Trompeter UCBJ224 (75-ohm) 4-leg connectors (King or ITT are also compatible). Use straight connectors on RG-59/U cable to connect to the high-density BNC EIA. Cisco recommends these cables for connection to a patch panel; they are designed for long runs. You can use high-density BNC EIAs for DS-3 (including the DS3XM-6 and DS3XM-12) or EC-1 cards. Figure 1-15 shows the ONS 15454 with preinstalled high-density BNC EIAs.

To install coaxial cable with high-density BNC connectors, refer to the “Install Shelf and Backplane Cable” in the *Cisco ONS 15454 Procedure Guide*.

Figure 1-15 High-Density BNC Backplane for Use in 1:N Protection Schemes

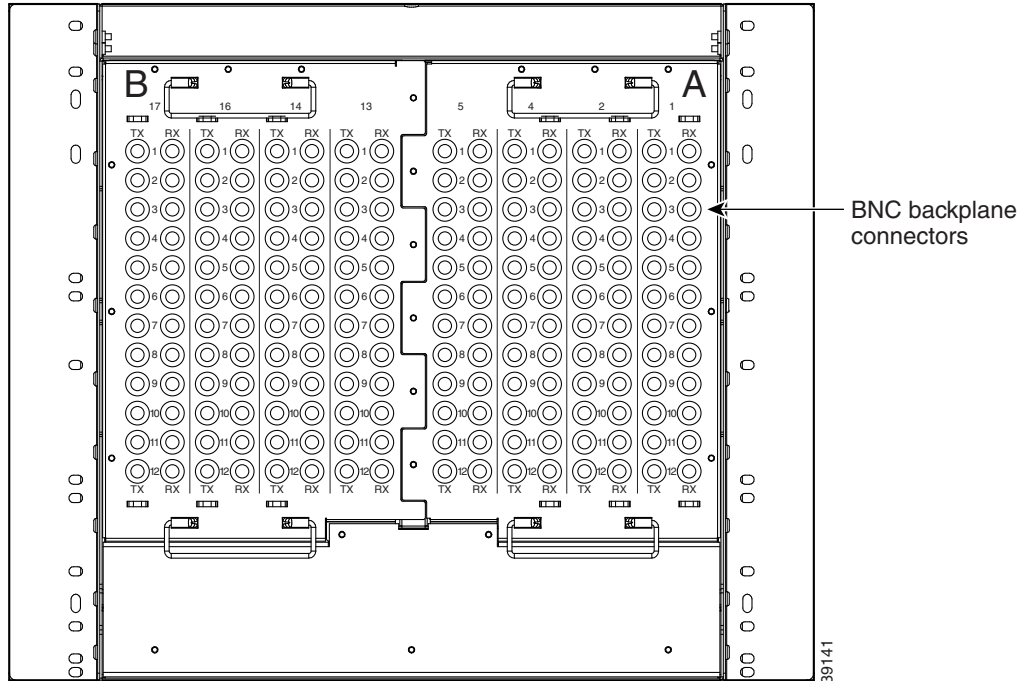

The EIA side marked “A” hosts 48 pairs of BNC connectors. Each column of connector pairs is numbered and corresponds to the slot of the same number. The first column (12 pairs) of BNC connectors corresponds to Slot 1 on the shelf assembly, the second column to Slot 2, the third column to Slot 4, and the fourth column to Slot 5. The rows of connectors correspond to Ports 1 to 12 of a 12-port card.

The EIA side marked “B” provides an additional 48 pairs of BNC connectors. The first column (12 pairs) of BNC connectors corresponds to Slot 13 on the shelf assembly, the second column to Slot 14, the third column to Slot 16, and the fourth column to Slot 17. The rows of connectors correspond to Ports 1 to 12 of a 12-port card. The BNC connector pairs are marked “Tx” and “Rx” to indicate transmit and receive cables for each port. The High-Density BNC EIA supports both 1:1 and 1:N protection across all slots except Slots 6 and 12.

1.5.5 MiniBNC EIA

The ONS 15454 MiniBNC EIA supports a maximum of 192 transmit and receive DS-3 connections, 96 per side (A and B) through 192 miniBNC connectors on each side. If you install BNC EIAs on both sides of the unit, the ONS 15454 hosts up to 192 circuits. The MiniBNC EIAs are designed to support DS-3 and EC-1 signals.

The MiniBNC EIA supports the following cards:

- DS3-12, DS3N-12
- DS3i-N-12
- DS3-12E, DS3N-12E
- EC1-12
- DS3XM-6
- DS3XM-12

- DS3/EC1-48

MiniBNCs support available high-density cards in unprotected and 1:N protection (where $N \leq 2$) protection groups.

Table 1-3 shows protection groups and their applicable slot assignments.

Table 1-3 MiniBNC Protection Types and Slots

Protection Type	Working Slots	Protection Slots
Unprotected	1–6, 12–17	—
1:1	2, 4, 6, 12, 14, 16	1, 3, 5, 13, 15, 17
1:N (HD, where $N \leq 5$)	1, 2, 16, 17	3, 15
1:N (LD, where $N \leq 2$)	1, 2, 4, 5, 6, 12, 13, 14, 16, 17	3, 15

1.5.5.1 MiniBNC Connectors

You can install MiniBNCs on one or both sides of the ONS 15454. As you face the rear of the ONS 15454 shelf assembly, the right side is the A side (15454-EIA-BNC-A96) and the left side is the B side (15454-EIA-BNC-A96). The diagrams adjacent to each row of connectors indicate the slots and ports that correspond with each connector in that row, depending on whether you are using a high density (HD) or low density (LD) configuration. The MiniBNC connector pairs are marked Tx and Rx to indicate transmit and receive cables for each port.

Figure 1-16 shows the ONS 15454 with preinstalled MiniBNC EIAs.

To install coaxial cable with MiniBNC connectors, refer to the “Install the Shelf and Backplane Cable” chapter in the *Cisco ONS 15454 Procedure Guide*.

Figure 1-16 MiniBNC Backplane for Use in 1:N Protection Schemes

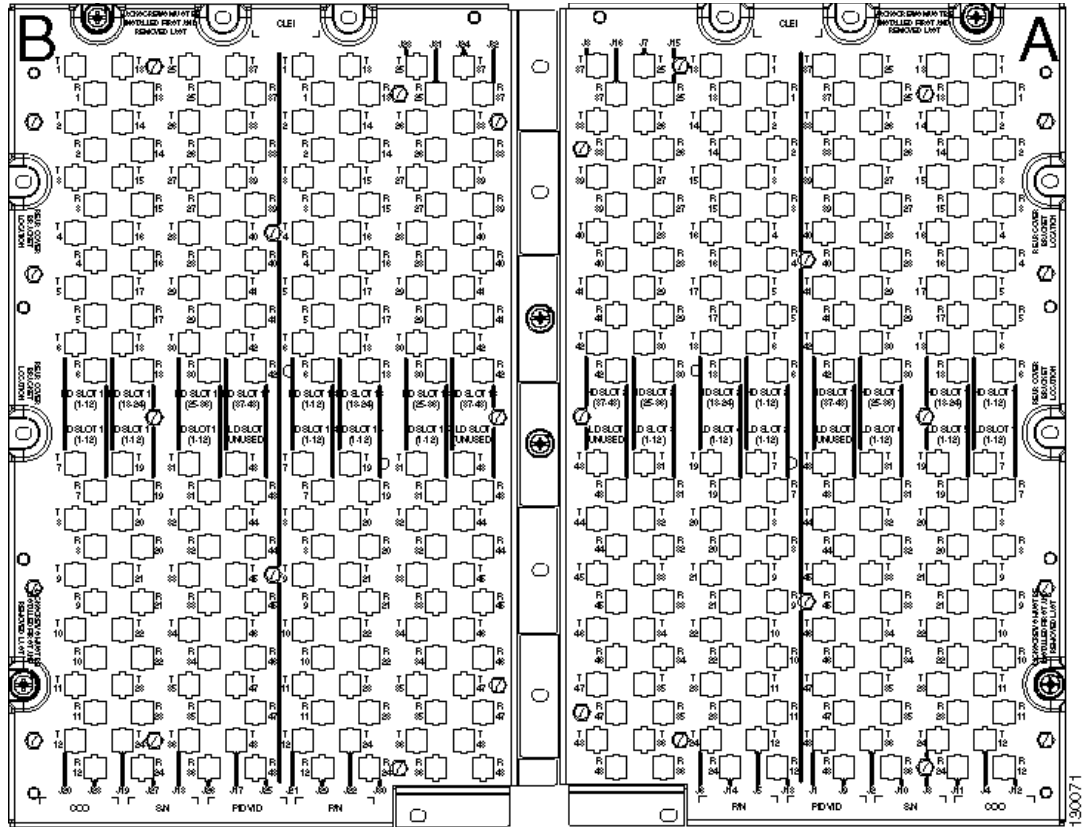

Table 1-4 and Table 1-5 show the J-labeling and corresponding card ports for a shelf assembly configured with low-density electrical cards.

Table 1-4 J-Labeling Port Assignments for a Shelf Assembly Configure with Low-Density Electrical Cards (A Side)

Slot	Port Type	TX	J4	J3	J2	J1	J5	J6	J7	J8
				T1	T13	T25	T37	T1	T13	T25
		T2	T14	T26	T38	T2	T14	T26	T38	
		T3	T15	T27	T39	T3	T15	T27	T39	
		T4	T16	T28	T40	T4	T16	T28	T40	
		T5	T17	T29	T41	T5	T17	T29	T41	
		T6	T18	T30	T42	T6	T18	T30	T42	
		T7	T19	T31	T43	T7	T19	T31	T43	
		T8	T20	T32	T44	T8	T20	T32	T44	
		T9	T21	T33	T45	T9	T21	T33	T45	
		T10	T22	T34	T46	T10	T22	T34	T46	
		T11	T23	T35	T47	T11	T23	T35	T47	
		T12	T24	T36	T48	T12	T24	T36	T48	
		RX	J12	J11	J10	J9	J13	J14	J15	J16
		R1	R13	R25	R37	R1	R13	R25	R37	
		R2	R14	R26	R38	R2	R14	R26	R38	
		R3	R15	R27	R39	R3	R15	R27	R39	
		R4	R16	R28	R40	R4	R16	R28	R40	
		R5	R17	R29	R41	R5	R17	R29	R41	
		R6	R18	R30	R42	R6	R18	R30	R42	
		R7	R19	R31	R43	R7	R19	R31	R43	
		R8	R20	R32	R44	R8	R20	R32	R44	
		R9	R21	R33	R45	R9	R21	R33	R45	
		R10	R22	R34	R46	R10	R22	R34	R46	
		R11	R23	R35	R47	R11	R23	R35	R47	
		R12	R24	R36	R48	R12	R24	R36	R48	
		Ports	Ports	Ports	Ports	Ports	Ports	Ports	Ports	Ports
1	LD DS-3	1-12	—	—	—	—	—	—	—	—
2	LD DS-3	—	—	—	—	1-12	—	—	—	—
3	LD DS-3	—	—	—	—	—	—	1-12	—	—
4	LD DS-3	—	—	—	—	—	1-12	—	—	—
5	LD DS-3	—	1-12	—	—	—	—	—	—	—
6	LD DS-3	—	—	1-12	—	—	—	—	—	—

Table 1-5 J-Labeling Port Assignments for a Shelf Assembly Configured with Low-Density Electrical Cards (B Side)

Slot	Port Type	TX	J20	J19	J18	J17	J21	J22	J23	J24
				T1	T13	T25	T37	T1	T13	T25
		T2	T14	T26	T38	T2	T14	T26	T38	
		T3	T15	T27	T39	T3	T15	T27	T39	
		T4	T16	T28	T40	T4	T16	T28	T40	
		T5	T17	T29	T41	T5	T17	T29	T41	
		T6	T18	T30	T42	T6	T18	T30	T42	
		T7	T19	T31	T43	T7	T19	T31	T43	
		T8	T20	T32	T44	T8	T20	T32	T44	
		T9	T21	T33	T45	T9	T21	T33	T45	
		T10	T22	T34	T46	T10	T22	T34	T46	
		T11	T23	T35	T47	T11	T23	T35	T47	
		T12	T24	T36	T48	T12	T24	T36	T48	
		RX	J28	J27	J26	J25	J29	J30	J31	J32
		R1	R13	R25	R37	R1	R13	R25	R37	
		R2	R14	R26	R38	R2	R14	R26	R38	
		R3	R15	R27	R39	R3	R15	R27	R39	
		R4	R16	R28	R40	R4	R16	R28	R40	
		R5	R17	R29	R41	R5	R17	R29	R41	
		R6	R18	R30	R42	R6	R18	R30	R42	
		R7	R19	R31	R43	R7	R19	R31	R43	
		R8	R20	R32	R44	R8	R20	R32	R44	
		R9	R21	R33	R45	R9	R21	R33	R45	
		R10	R22	R34	R46	R10	R22	R34	R46	
		R11	R23	R35	R47	R11	R23	R35	R47	
		R12	R24	R36	R48	R12	R24	R36	R48	
		Ports	Ports	Ports	Ports	Ports	Ports	Ports	Ports	Ports
17	LD DS-3	1-12	—	—	—	—	—	—	—	—
16	LD DS-3	—	—	—	—	1-12	—	—	—	—
15	LD DS-3	—	—	—	—	—	—	1-12	—	—
14	LD DS-3	—	—	—	—	—	1-12	—	—	—
13	LD DS-3	—	1-12	—	—	—	—	—	—	—
12	LD DS-3	—	—	1-12	—	—	—	—	—	—

Table 1-6 and Table 1-7 show the J-labeling and corresponding card ports for a shelf assembly configured with high-density 48-port DS-3/EC-1 electrical cards.

Table 1-6 J-Labeling Port Assignments for a Shelf Configured with High-Density Electrical Cards (A Side)

Slot	Port Type	TX	J4	J3	J2	J1	J5	J6	J7	J8
				T1	T13	T25	T37	T1	T13	T25
		T2	T14	T26	T38	T2	T14	T26	T38	
		T3	T15	T27	T39	T3	T15	T27	T39	
		T4	T16	T28	T40	T4	T16	T28	T40	
		T5	T17	T29	T41	T5	T17	T29	T41	
		T6	T18	T30	T42	T6	T18	T30	T42	
		T7	T19	T31	T43	T7	T19	T31	T43	
		T8	T20	T32	T44	T8	T20	T32	T44	
		T9	T21	T33	T45	T9	T21	T33	T45	
		T10	T22	T34	T46	T10	T22	T34	T46	
		T11	T23	T35	T47	T11	T23	T35	T47	
		T12	T24	T36	T48	T12	T24	T36	T48	
		RX	J12	J11	J10	J9	J13	J14	J15	J16
		R1	R13	R25	R37	R1	R13	R25	R37	
		R2	R14	R26	R38	R2	R14	R26	R38	
		R3	R15	R27	R39	R3	R15	R27	R39	
		R4	R16	R28	R40	R4	R16	R28	R40	
		R5	R17	R29	R41	R5	R17	R29	R41	
		R6	R18	R30	R42	R6	R18	R30	R42	
		R7	R19	R31	R43	R7	R19	R31	R43	
		R8	R20	R32	R44	R8	R20	R32	R44	
		R9	R21	R33	R45	R9	R21	R33	R45	
		R10	R22	R34	R46	R10	R22	R34	R46	
		R11	R23	R35	R47	R11	R23	R35	R47	
		R12	R24	R36	R48	R12	R24	R36	R48	
		Ports	Ports	Ports	Ports	Ports	Ports	Ports	Ports	Ports
1	HD DS-3	1–12	13–24	25–36	37–48	—	—	—	—	
2	HD DS-3	—	—	—	—	1–12	13–24	25–36	37–48	

Table 1-7 J-Labeling Port Assignments for a Shelf Configured with High-Density Electrical Cards (B Side)

Slot	Port Type	TX	J20	J19	J18	J17	J21	J22	J23	J24
				T1	T13	T25	T37	T1	T13	T25
		T2	T14	T26	T38	T2	T14	T26	T38	
		T3	T15	T27	T39	T3	T15	T27	T39	
		T4	T16	T28	T40	T4	T16	T28	T40	
		T5	T17	T29	T41	T5	T17	T29	T41	
		T6	T18	T30	T42	T6	T18	T30	T42	
		T7	T19	T31	T43	T7	T19	T31	T43	
		T8	T20	T32	T44	T8	T20	T32	T44	
		T9	T21	T33	T45	T9	T21	T33	T45	
		T10	T22	T34	T46	T10	T22	T34	T46	
		T11	T23	T35	T47	T11	T23	T35	T47	
		T12	T24	T36	T48	T12	T24	T36	T48	
		RX	J28	J27	J26	J25	J29	J30	J31	J32
		R1	R13	R25	R37	R1	R13	R25	R37	
		R2	R14	R26	R38	R2	R14	R26	R38	
		R3	R15	R27	R39	R3	R15	R27	R39	
		R4	R16	R28	R40	R4	R16	R28	R40	
		R5	R17	R29	R41	R5	R17	R29	R41	
		R6	R18	R30	R42	R6	R18	R30	R42	
		R7	R19	R31	R43	R7	R19	R31	R43	
		R8	R20	R32	R44	R8	R20	R32	R44	
		R9	R21	R33	R45	R9	R21	R33	R45	
		R10	R22	R34	R46	R10	R22	R34	R46	
		R11	R23	R35	R47	R11	R23	R35	R47	
		R12	R24	R36	R48	R12	R24	R36	R48	
		Ports	Ports	Ports	Ports	Ports	Ports	Ports	Ports	Ports
17	HD DS-3	1–12	13–24	25–36	37–48	—	—	—	—	—
16	HD DS-3	—	—	—	—	1–12	13–24	25–36	37–48	—

1.5.5.2 MiniBNC Insertion and Removal Tool

Due to the large number of MiniBNC connectors on the MiniBNC EIA, you might require a special tool for inserting and removing MiniBNC EIAs (Figure 1-17). This tool also helps with ONS 15454 patch panel connections.

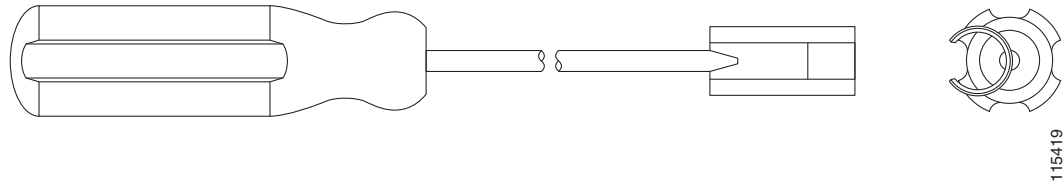
Figure 1-17 MiniBNC Insertion and Removal Tool

This tool can be obtained with P/N 227-T1000 from:

Amphenol USA (www.amphenol.com)
 One Kennedy Drive
 Danbury, CT 06810
 Phone: 203 743-9272 Fax: 203 796-2032

This tool can be obtained with P/N RT-1L from:

Trompeter Electronics Inc. (www.trompeter.com)
 31186 La Baya Drive
 Westlake Village, CA 91362-4047
 Phone: 800 982-2629 Fax: 818 706-1040

1.5.6 SMB EIA

The ONS 15454 SMB EIA supports AMP 415484-1 75-ohm 4-leg connectors. Right-angle mating connectors for the connecting cable are AMP 415484-2 (75-ohm) connectors. Use RG-179/U cable to connect to the ONS 15454 EIA. Cisco recommends these cables for connection to a patch panel; they are not designed for long runs. Range does not affect loopback testing.

You can use SMB EIAs with DS-1, DS-3 (including the DS3XM-6 and DS3XM-12), and EC-1 cards. If you use DS-1 cards, use the DS-1 electrical interface adapter (balun) to terminate the twisted pair DS-1 cable to the SMB EIA (see the “[1.7.2 Electrical Interface Adapters](#)” section on page 1-38). SMB EIAs support 14 ports per slot when used with a DS-1 card, 12 ports per slot when used with a DS-3 or EC-1 card, and 6 ports per slot when used with a DS3XM-6 card.

[Figure 1-18](#) shows the ONS 15454 with preinstalled SMB EIAs and the sheet metal cover and screw locations for the EIA. The SMB connectors on the EIA are AMP 415504-3 (75-ohm) 4-leg connectors.

To install SMB connectors, refer to the “Install Shelf and Backplane Cable” chapter in the *Cisco ONS 15454 Procedure Guide*.

Figure 1-18 SMB EIA Backplane

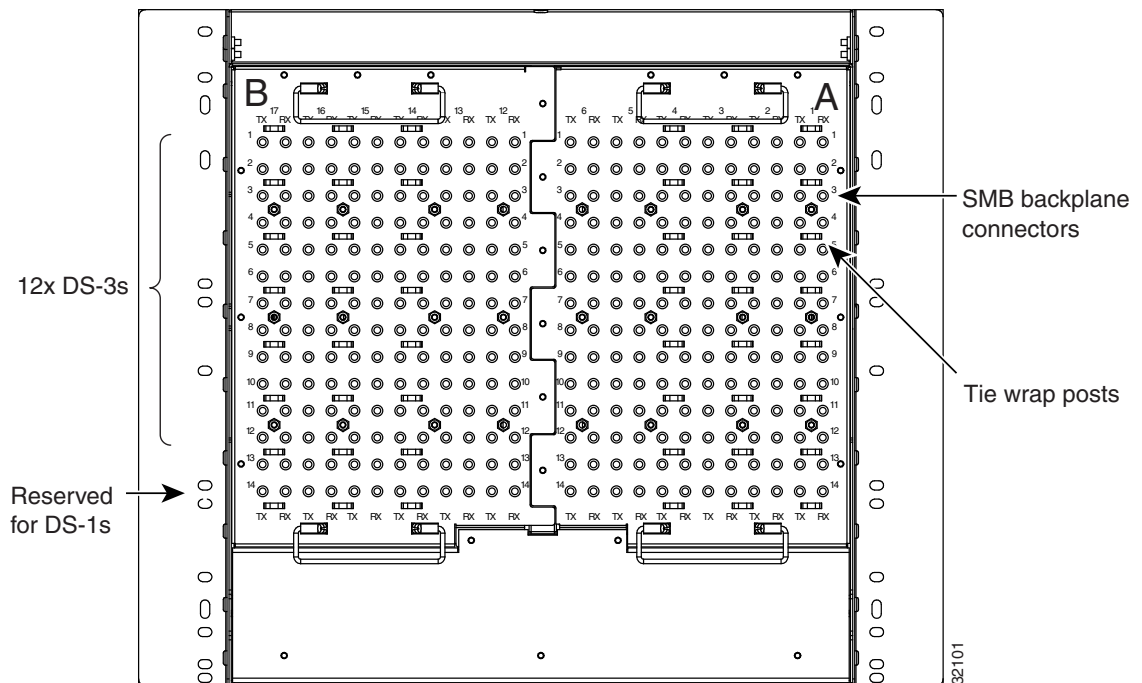

The SMB EIA has 84 transmit and 84 receive connectors on each side of the ONS 15454 for a total of 168 SMB connectors (84 circuits).

The EIA side marked “A” hosts 84 SMB connectors in six columns of 14 connectors. The “A” side columns are numbered 1 to 6 and correspond to Slots 1 to 6 on the shelf assembly. The EIA side marked “B” hosts an additional 84 SMB connectors in six columns of 14 connectors. The “B” side columns are numbered 12 to 17 and correspond to Slots 12 to 17 on the shelf assembly. The connector rows are numbered 1 to 14 and correspond to the 14 ports on a DS-1 card.

For DS-3 or EC-1 cards, the EIA supports 72 transmit and 72 receive connectors, for a total of 144 SMB connectors (72 circuits). If you use a DS-3 or EC-1 card, only Ports 1 to 12 are active. If you use a DS3XM-6 card, only Ports 1 to 6 are active. The SMB connector pairs are marked “Tx” and “Rx” to identify transmit and receive cables for each port. If you use SMB connectors, you can install DS-1, DS-3, or EC-1 cards in Slots 1 to 4 or 14 to 17.

1.5.7 AMP Champ EIA

The ONS 15454 AMP Champ EIA supports 64-pin (32 pair) AMP Champ connectors for each slot on both sides of the shelf assembly where the EIA is installed. Cisco AMP Champ connectors are female AMP # 552246-1 with AMP # 552562-2 bail locks. Each AMP Champ connector supports 14 DS-1 ports. You can use AMP Champ EIAs with DS-1 cards only. [Figure 1-19](#) shows the ONS 15454 with preinstalled AMP Champ EIAs and the corresponding sheet metal cover and screw locations for the EIA.

To install AMP Champ connector DS-1 cables, you must use 64-pin bundled cable connectors with a 64-pin male AMP Champ connector. You need an AMP Champ connector #552276-1 for the receptacle side and #1-552496-1 (for cable diameter 0.475 in. to 0.540 in.) or #2-552496-1 (for cable diameter 0.540 in. to 0.605 in.) for the right-angle shell housing (or their functional equivalent). The corresponding 64-pin female AMP Champ connector on the AMP Champ EIA supports one receive and one transmit for each DS-1 port for the corresponding card slot.

Because each DS1-14 card supports 14 DS-1 ports, only 56 pins (28 pairs) of the 64-pin connector are used. Prepare one 56-wire cable for each DS-1 facility installed.

Figure 1-19 AMP Champ EIA Backplane

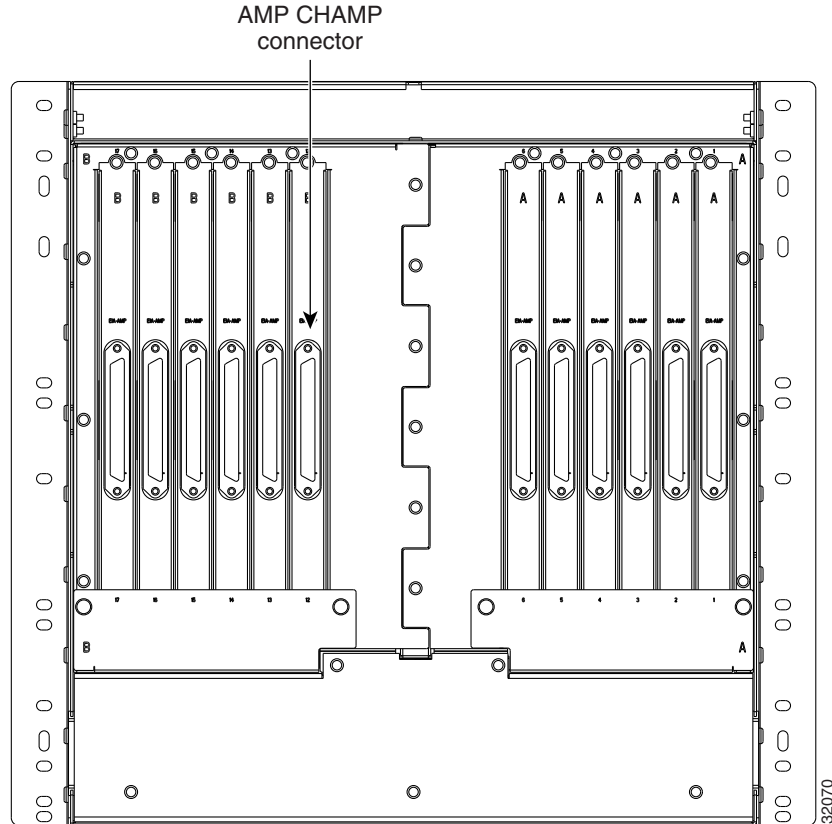

Table 1-8 shows the pin assignments for the AMP Champ connectors on the ONS 15454 AMP Champ EIA. The EIA side marked “A” hosts six AMP Champ connectors. The connectors are numbered 1 to 6 for the corresponding slots on the shelf assembly. Each AMP Champ connector on the backplane supports 14 DS-1 ports for a DS1-14 card, and each connector features 28 live pairs—one transmit pair and one receive pair—for each DS-1 port.

The EIA side marked “B” hosts six AMP Champ connectors. The connectors are labeled 12 to 17 for the corresponding slots on the shelf assembly. Each AMP Champ connector on the backplane supports 14 DS-1 ports for a DS1-14 card, and each connector features 28 live pairs—one transmit pair and one receive pair—for each DS-1 port.



Note

EIAs are hot-swappable. You do not need to disconnect power to install or remove EIAs.



Caution

Always use an electrostatic discharge (ESD) wristband when working with a powered ONS 15454. Plug the wristband cable into the ESD jack located on the lower-right outside edge of the shelf assembly.

Table 1-8 AMP Champ Connector Pin Assignments

Signal/Wire	Pin	Pin	Signal/Wire	Signal/Wire	Pin	Pin	Signal/Wire
Tx Tip 1 white/blue	1	33	Tx Ring 1 blue/white	Rx Tip 1 yellow/orange	17	49	Rx Ring 1 orange/yellow
Tx Tip 2 white/orange	2	34	Tx Ring 2 orange/white	Rx Tip 2 yellow/green	18	50	Rx Ring 2 green/yellow
Tx Tip 3 white/green	3	35	Tx Ring 3 green/white	Rx Tip 3 yellow/brown	19	51	Rx Ring 3 brown/yellow
Tx Tip 4 white/brown	4	36	Tx Ring 4 brown/white	Rx Tip 4 yellow/slate	20	52	Rx Ring 4 slate/yellow
Tx Tip 5 white/slate	5	37	Tx Ring 5 slate/white	Rx Tip 5 violet/blue	21	53	Rx Ring 5 blue/violet
Tx Tip 6 red/blue	6	38	Tx Ring 6 blue/red	Rx Tip 6 violet/orange	22	54	Rx Ring 6 orange/violet
Tx Tip 7 red/orange	7	39	Tx Ring 7 orange/red	Rx Tip 7 violet/green	23	55	Rx Ring 7 green/violet
Tx Tip 8 red/green	8	40	Tx Ring 8 green/red	Rx Tip 8 violet/brown	24	56	Rx Ring 8 brown/violet
Tx Tip 9 red/brown	9	41	Tx Ring 9 brown/red	Rx Tip 9 violet/slate	25	57	Rx Ring 9 slate/violet
Tx Tip 10 red/slate	10	42	Tx Ring 10 slate/red	Rx Tip 10 white/blue	26	58	Rx Ring 10 blue/white
Tx Tip 11 black/blue	11	43	Tx Ring 11 blue/black	Rx Tip 11 white/orange	27	59	Rx Ring 11 orange/white
Tx Tip 12 black/orange	12	44	Tx Ring 12 orange/black	Rx Tip 12 white/green	28	60	Rx Ring 12 green/white
Tx Tip 13 black/green	13	45	Tx Ring 13 green/black	Rx Tip 13 white/brown	29	61	Rx Ring 13 brown/white
Tx Tip 14 black/brown	14	46	Tx Ring 14 brown/black	Rx Tip 14 white/slate	30	62	Rx Ring 14 slate/white
Tx Spare0+ N/A	15	47	Tx Spare0- N/A	Rx Spare0+ N/A	31	63	Rx Spare0- N/A
Tx Spare1+ N/A	16	48	Tx Spare1- N/A	Rx Spare1+ N/A	32	64	Rx Spare1- N/A

Table 1-9 shows the pin assignments for the AMP Champ connectors on the ONS 15454 AMP Champ EIA for a shielded DS-1 cable.

Table 1-9 AMP Champ Connector Pin Assignments (Shielded DS-1 Cable)

64-Pin Blue Bundle				64-Pin Orange Bundle			
Signal/Wire	Pin	Pin	Signal/Wire	Signal/Wire	Pin	Pin	Signal/Wire
Tx Tip 1 white/blue	1	33	Tx Ring 1 blue/white	Rx Tip 1 white/blue	17	49	Rx Ring 1 blue/white
Tx Tip 2 white/orange	2	34	Tx Ring 2 orange/white	Rx Tip 2 white/orange	18	50	Rx Ring 2 orange/white

Table 1-9 AMP Champ Connector Pin Assignments (Shielded DS-1 Cable) (continued)

64-Pin Blue Bundle				64-Pin Orange Bundle			
Signal/Wire	Pin	Pin	Signal/Wire	Signal/Wire	Pin	Pin	Signal/Wire
Tx Tip 3 white/green	3	35	Tx Ring 3 green/white	Rx Tip 3 white/green	19	51	Rx Ring 3 green/white
Tx Tip 4 white/brown	4	36	Tx Ring 4 brown/white	Rx Tip 4 white/brown	20	52	Rx Ring 4 brown/white
Tx Tip 5 white/slate	5	37	Tx Ring 5 slate/white	Rx Tip 5 white/slate	21	53	Rx Ring 5 slate/white
Tx Tip 6 red/blue	6	38	Tx Ring 6 blue/red	Rx Tip 6 red/blue	22	54	Rx Ring 6 blue/red
Tx Tip 7 red/orange	7	39	Tx Ring 7 orange/red	Rx Tip 7 red/orange	23	55	Rx Ring 7 orange/red
Tx Tip 8 red/green	8	40	Tx Ring 8 green/red	Rx Tip 8 red/green	24	56	Rx Ring 8 green/red
Tx Tip 9 red/brown	9	41	Tx Ring 9 brown/red	Rx Tip 9 red/brown	25	57	Rx Ring 9 brown/red
Tx Tip 10 red/slate	10	42	Tx Ring 10 slate/red	Rx Tip 10 red/slate	26	58	Rx Ring 10 slate/red
Tx Tip 11 black/blue	11	43	Tx Ring 11 blue/black	Rx Tip 11 black/blue	27	59	Rx Ring 11 blue/black
Tx Tip 12 black/orange	12	44	Tx Ring 12 orange/black	Rx Tip 12 black/orange	28	60	Rx Ring 12 orange/black
Tx Tip 13 black/green	13	45	Tx Ring 13 green/black	Rx Tip 13 black/green	29	61	Rx Ring 13 green/black
Tx Tip 14 black/brown	14	46	Tx Ring 14 brown/black	Rx Tip 14 black/brown	30	62	Rx Ring 14 brown/black
Tx Tip 15 black/slate	15	47	Tx Tip 15 slate/black	Rx Tip 15 black/slate	31	63	Rx Tip 15 slate/black
Tx Tip 16 yellow/blue	16	48	Tx Tip 16 blue/yellow	Rx Tip 16 yellow/blue	32	64	Rx Tip 16 blue/yellow

When using DS-1 AMP Champ cables, you must equip the ONS 15454 with an AMP Champ connector EIA on each side of the backplane where DS-1 cables will terminate. Each AMP Champ connector on the EIA corresponds to a slot in the shelf assembly and is numbered accordingly. The AMP Champ connectors have screw-down tooling at each end of the connector.

When the DS1N-14 card is installed in an ONS 15454 shelf that has an AMP Champ EIA, the cable that connects the AMP Champ connector with the traffic source must be connected to the ground on both the sides to meet the EMC standard.

1.5.8 UBIC-V EIA

UBIC-V EIAs are attached to the shelf assembly backplane to provide up to 112 transmit and receive connections through 16 SCSI connectors per side (A and B). The UBIC-V EIAs are designed to support DS-1, DS-3, and EC-1 signals. The appropriate cable assembly is required depending on the type of signal.

You can install UBIC-Vs on one or both sides of the ONS 15454. As you face the rear of the ONS 15454 shelf assembly, the right side is the A side (15454-EIA-UBICV-A) and the left side is the B side (15454-EIA-UBICV-B). The diagrams adjacent to each row of SCSI connectors indicate the slots and ports that correspond with each SCSI connector in that row, depending on whether you are using a high-density (HD) or low-density (LD) configuration.

UBIC-V EIAs will support high-density electrical cards (DS3/EC1-48, DS1/E1-56), as well as low-density electrical cards.

Figure 1-20 shows the A- and B-side slot assignments.

Figure 1-20 UBIC-V Slot Designations

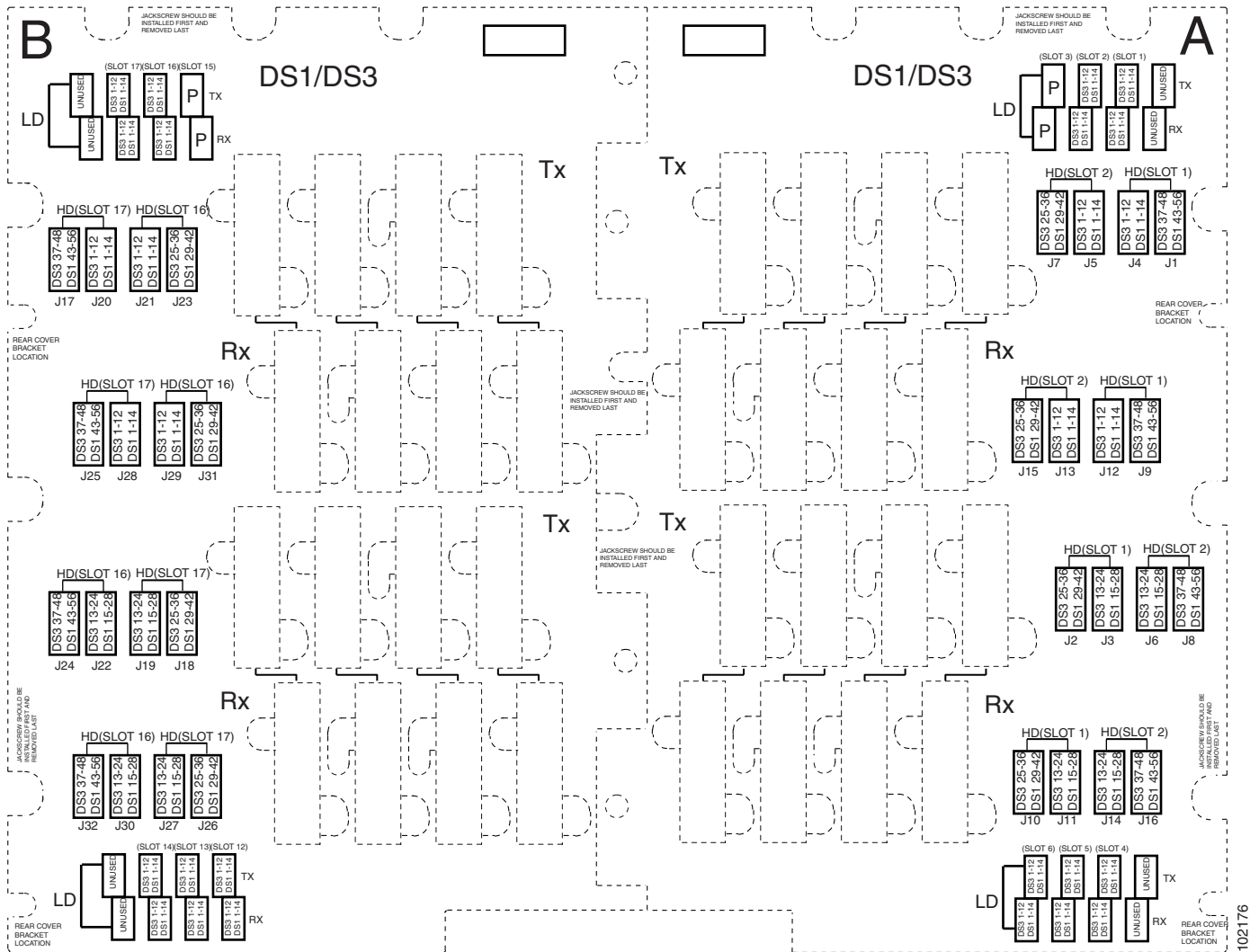

102176

The UBIC-V sheet metal covers use the same screw holes as the standard sheet metal covers, but they have 12 additional holes for pan-head screws and three holes for jack screws, so you can screw down the cover and the board using standoffs on the UBIC-V board.

When installed with the standard door and cabling on the backplane, the ONS 15454 shelf measures approximately 15.7 inches (399 mm) deep when partially populated with backplane cables, 16.1 inches (409 mm) deep when fully populated, and 16.75 inches (425 mm) deep with the rear cover installed. When installed with the deep door and cabling on the backplane, the ONS 15454 shelf measures approximately 17.5 inches (445 mm) deep when partially populated with backplane cables, 17.9 inches (455 mm) deep when fully populated, and 18.55 inches (471 mm) deep with the rear cover installed.

The UBIC-V EIA supports the following cards:

- DS1-14, DS1N-14
- DS3-12, DS3N-12
- DS3i-N-12
- DS3-12E, DS3N-12E
- EC1-12
- DS3XM-6
- DS3XM-12
- DS3/EC1-48
- DS1/E1-56

The A and B sides each host 16 high-density, 50-pin SCSI connectors. The A-side maps to Slots 1 through 6 and the B-side maps to Slots 12 through 17.

In Software Releases 4.1.x and 4.6, UBIC-Vs support unprotected, 1:1, and 1:N ($N \leq 5$) protection groups. In Software R5.0 and later, UBIC-Vs also support available high-density cards in unprotected and 1:N ($N \leq 2$) protection groups.

Table 1-10 shows the UBIC-V protection types and their applicable slot assignments.

Table 1-10 UBIC-V Protection Types and Slots

Protection Type	Working Slots	Protection Slots
Unprotected	1–6, 12–17	—
1:1	2, 4, 6, 12, 14, 16	1, 3, 5, 13, 15, 17
1:2	1, 2, 16, 17	3, 15
1:5	1, 2, 4, 5, 6, 12, 13, 14, 16, 17	3, 15

1.5.9 UBIC-H EIA

UBIC-H EIAs are attached to the shelf assembly backplane to provide up to 112 transmit and receive DS-1 connections through 16 SCSI connectors per side (A and B) or 96 transmit and receive DS-3 connections. The UBIC-H EIAs are designed to support DS-1, DS-3, and EC-1 signals. The appropriate cable assembly is required depending on the type of signal.

You can install UBIC-Hs on one or both sides of the ONS 15454. As you face the rear of the ONS 15454 shelf assembly, the right side is the A side (15454-EIA-UBICH-A) and the left side is the B side (15454-EIA-UBICH-B). The diagrams adjacent to each row of SCSI connectors indicate the slots and ports that correspond with each SCSI connector in that row, depending on whether you are using a high density (HD) or low density (LD) configuration.

**Note**

UBIC-H EIAs will support use with the high-density (DS3/EC1-48, DS1/E1-56, and DS3XM-12) electrical cards, as well as existing low-density electrical cards.

Figure 1-21 shows the A- and B-side connector labeling.

Figure 1-21 UBIC-H EIA Connector Labeling

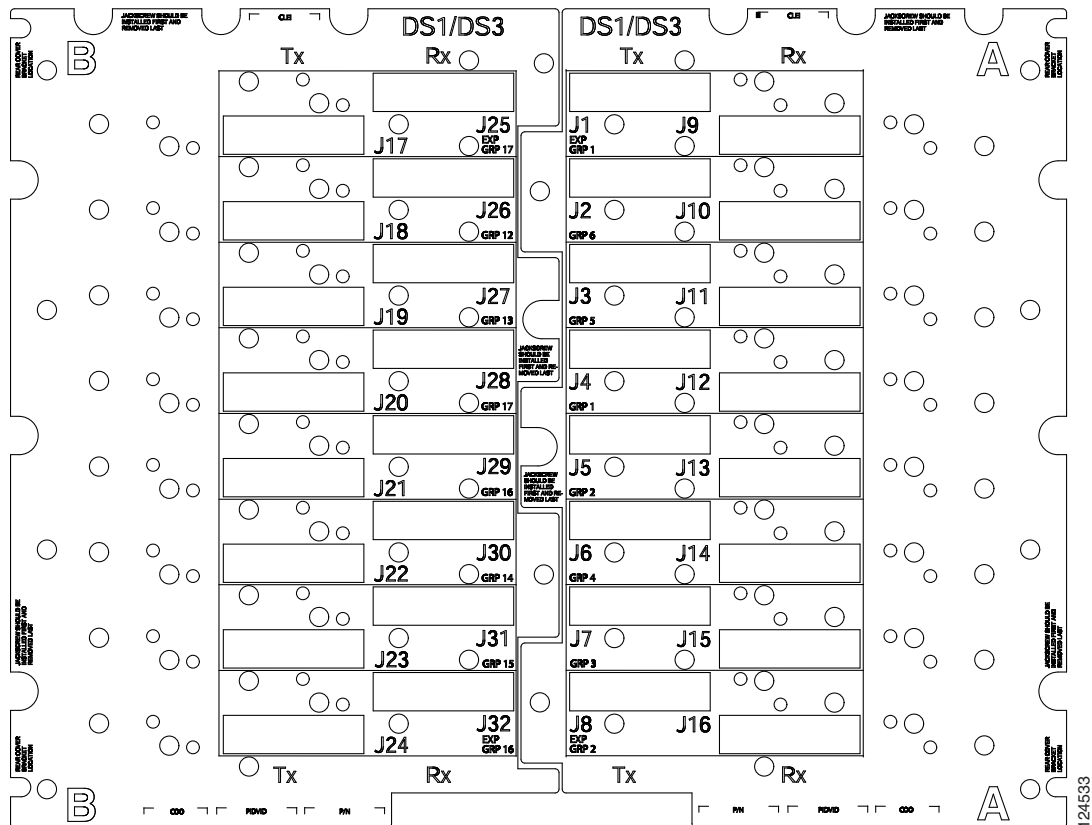

Tables 1-11 and 1-12 show the J-labeling and corresponding card ports for a shelf assembly configured with low-density electrical cards.

Table 1-11 J-Labeling Port Assignments for a Shelf Assembly Configured with Low-Density Electrical Cards (A Side)

Slot	Port Type	TX	J4	J3	J2	J1	J5	J6	J7	J8
		RX	J12	J11	J10	J9	J13	J14	J15	J16
			Ports	Ports	Ports	Ports	Ports	Ports	Ports	Ports
1	DS-1		1–14	—	—	—	—	—	—	—
	DS-3		1–12	—	—	—	—	—	—	—
2	DS-1		—	—	—	—	1–14	—	—	—
	DS-3		—	—	—	—	1–12	—	—	—
3	DS-1		—	—	—	—	—	—	1–14	—
	DS-3		—	—	—	—	—	—	1–12	—
4	DS-1		—	—	—	—	—	1–14	—	—
	DS-3		—	—	—	—	—	1–12	—	—
5	DS-1		—	1–14	—	—	—	—	—	—
	DS-3		—	1–12	—	—	—	—	—	—
6	DS-1		—	—	1–14	—	—	—	—	—
	DS-3		—	—	1–12	—	—	—	—	—

Table 1-12 J-Labeling Port Assignments for a Shelf Assembly Configured with Low-Density Electrical Cards (B Side)

Slot	Port Type	TX	J20	J19	J18	J17	J21	J22	J23	24
		RX	J28	J27	J26	J25	J29	J30	J31	J32
			Ports	Ports	Ports	Ports	Ports	Ports	Ports	Ports
17	DS-1		1–14	—	—	—	—	—	—	—
	DS-3		1–12	—	—	—	—	—	—	—
16	DS-1		—	—	—	—	1–14	—	—	—
	DS-3		—	—	—	—	1–12	—	—	—
15	DS-1		—	—	—	—	—	—	1–14	—
	DS-3		—	—	—	—	—	—	1–12	—
14	DS-1		—	—	—	—	—	1–14	—	—
	DS-3		—	—	—	—	—	1–12	—	—
13	DS-1		—	1–14	—	—	—	—	—	—
	DS-3		—	1–12	—	—	—	—	—	—
12	DS-1		—	—	1–14	—	—	—	—	—
	DS-3		—	—	1–12	—	—	—	—	—

Tables 1-13 and 1-14 show the J-labeling and corresponding card ports for a shelf assembly configured with high-density 48-port DS-3/EC-1 or 56-port DS-1 electrical cards.

Table 1-13 J-Labeling Port Assignments for a Shelf Configured with High-Density Electrical Cards (A Side)

Slot	Port Type	TX	J4	J3	J2	J1	J5	J6	J7	J8
		RX	J12	J11	J10	J9	J13	J14	J15	J16
			Ports	Ports	Ports	Ports	Ports	Ports	Ports	Ports
1	DS-1		1–14	15–28	29–42	43–56	—	—	—	—
	DS-3		1–12	13–24	25–36	37–48	—	—	—	—
2	DS-1		—	—	—	—	1–14	15–28	29–42	43–56
	DS-3		—	—	—	—	1–12	13–24	25–36	37–48

Table 1-14 J-Labeling Port Assignments for a Shelf Configured with High-Density Electrical Cards (B Side)

Slot	Port Type	TX	J20	J19	J18	J17	J21	J22	J23	24
		RX	J28	J27	J26	J25	J29	J30	J31	J32
			Ports	Ports	Ports	Ports	Ports	Ports	Ports	Ports
17	DS-1		1–14	15–28	29–42	43–56	—	—	—	—
	DS-3		1–12	13–24	25–36	37–48	—	—	—	—
16	DS-1		—	—	—	—	1–14	15–28	29–42	43–56
	DS-3		—	—	—	—	1–12	13–24	25–36	37–48

If you are installing UBIC-H EIAs after the shelf assembly is installed, plug the UBIC-H EIA into the backplane. The UBIC-H backplane must replace the standard sheet metal cover to provide access to the cable connectors. The UBIC-H sheet metal covers use the same screw holes as the standard sheet metal covers, but they have 12 additional holes for panhead screws and three holes for jack screws so you can screw down the cover and the board using standoffs on the UBIC-H board.

When installed with the standard door and cabling on the backplane, the ONS 15454 shelf measures approximately 14.5 inches deep when fully populated with backplane cables, and 15.0 inches deep with the rear cover installed. When installed with the deep door and cabling on the backplane, the ONS 15454 shelf measures approximately 16.5 inches deep when fully populated with backplane cables, and 17.0 inches deep with the rear cover installed.

The UBIC-H EIA supports the following cards:

- DS1-14, DS1N-14
- DS3-12, DS3N-12
- DS3-12E, DS3N-12E
- EC1-12
- DS3XM-6
- DS3XM-12
- DS3/EC1-48
- DS1/E1-56

The A and B sides each host 16 high-density, 50-pin SCSI connectors. The A-side maps to Slots 1 through 6 and the B-side maps to Slots 12 through 17.

In Software Releases prior to Release 5.0, UBIC-Hs support unprotected, 1:1, and 1:N (where $N \leq 5$) protection groups. In Software R5.0 and greater, UBIC-Hs additionally support available high-density cards in unprotected and 1:N protection (where $N \leq 2$) protection groups.

Table 1-15 shows protection groups and their applicable slot assignments.

Table 1-15 UBIC-H Protection Types and Slots

Protection Type	Working Slots	Protection Slots
Unprotected	1–6, 12–17	—
1:1	2, 4, 6, 12, 14, 16	1, 3, 5, 13, 15, 17
1:2	1, 2, 16, 17	3, 15
1:5	1, 2, 4, 5, 6, 12, 13, 14, 16, 17	3, 15

1.5.10 EIA Replacement

Before you attach a new EIA, you must remove the backplane cover or EIA already installed on the ONS 15454. Refer to the spare document(s) for the EIA type(s) you are removing and replacing for specific information.

1.6 Coaxial Cable



Caution

Always use the supplied ESD wristband when working with a powered ONS 15454. Plug the wristband cable into the ESD jack located on the lower-right outside edge of the shelf assembly.

When using ONS 15454 DS-3 electrical cables, the cables must terminate on an EIA installed on the ONS 15454 backplane. All DS-3 cables connected to the ONS 15454 DS-3 card must terminate with coaxial cables using the desired connector type to connect to the specified EIA.

The electromagnetic compatibility (EMC) performance of the node depends on good-quality DS-3 coaxial cables, such as Shuner Type G 03233 D, or the equivalent.

1.7 DS-1 Cable

DS-1 cables support AMP Champ connectors and twisted-pair wire-wrap cabling. Twisted-pair wire-wrap cables require SMB EIAs.

1.7.1 Twisted Pair Wire-Wrap Cables

Installing twisted-pair, wire-wrap DS-1 cables requires separate pairs of grounded twisted-pair cables for receive (in) and transmit (out). Prepare four cables, two for receive and two for transmit, for each DS-1 facility to be installed.

**Caution**

Always use the supplied ESD wristband when working with a powered ONS 15454. Plug the wristband cable into the ESD jack located on the lower-right outside edge of the shelf assembly.

If you use DS-1 electrical twisted-pair cables, equip the ONS 15454 with an SMB EIA on each side of the backplane where DS-1 cables will terminate. You must install special DS-1 electrical interface adapters, commonly referred to as a balun, on every transmit and receive connector for each DS-1 termination.

1.7.2 Electrical Interface Adapters

**Note**

DS-1 electrical interface adapters project an additional 1.72 inches (43.7 mm) from the ONS 15454 backplane.

If you install DS-1 cards in the ONS 15454, you must fit the corresponding transmit and receive SMB connectors on the EIA with a DS-1 electrical interface adapter. You can install the adapter on the SMB connector for the port. The adapter has wire-wrap posts for DS-1 transmit and receive cables.

Figure 1-22 shows the DS-1 electrical interface adapter.

**Note**

“EIA” refers to electrical interface assemblies and not electrical interface adapters. Electrical interface adapters are also known as baluns.

Figure 1-22 DS-1 Electrical Interface Adapter (Balun)

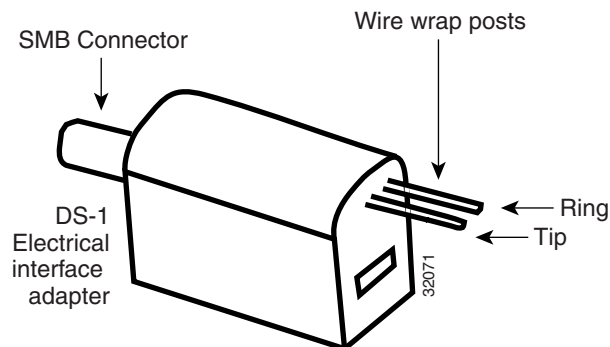

Each DS-1 electrical interface adapter has a female SMB connector on one end and a pair of 0.045 inch (1.14 mm) square wire-wrap posts on the other end. The wire-wrap posts are 0.200 inches (5.08 mm) apart.

**Caution**

Always use the supplied ESD wristband when working with a powered ONS 15454. Plug the wristband cable into the ESD jack located on the lower-right outside edge of the shelf assembly.

1.8 UBIC-V Cables



Note

Cisco Systems announced the end-of-sale and end-of-life dates for the Cisco ONS 15454 MSPP Universal BackPlane Interface Adapter, Vertical Orientation (UBIC-V), and its DS1 and DS3 Cables. For further details, refer to Product Bulletin No. EOL5039 at http://www.cisco.com/en/US/products/hw/optical/ps2006/prod_eol_notices_list.html

The UBIC-V EIA is designed to support DS-1, DS-3, or EC-1 signals. The type of signal supported is determined by the respective UBIC-V cable assembly.

DS-1 cables for the UBIC-V have a maximum supported distance of 655 feet (199.6 m). DS-1 cables arrive with unterminated #24 AWG twisted pairs on the far end and are color coded as identified in [Table 1-17](#).

The following DS-1 cables are no longer available from Cisco Systems for use with the UBIC-V EIA:

- DS-1 cable, 150 feet: 15454-CADS1-SD
- DS-1 cable, 250 feet: 15454-CADS1-ID
- DS-1 cable, 655 feet: 15454-CADS1-LD

DS-3/EC-1 cables for the UBIC-V have a maximum supported distance of 450 feet (137.2 m). DS-3/EC-1 cables arrive with unterminated coaxial cable at the far end and labeled with the respective port number. 75-ohm BNC connectors for each port (qty. 12) are supplied and require that they be crimped on.

The following DS-3/EC-1 cables are no longer available from Cisco Systems for use with the UBIC-V EIA:

- DS-3/EC-1 cable, 75 feet: 15454-CADS3-SD
- DS-3/EC-1 cable, 225 feet: 15454-CADS3-ID
- DS-3/EC-1 cable, 450 feet: 15454-CADS3-LD

[Figure 1-23](#) identifies the pin numbers for the DS-1 and DS-3/EC-1 cables as referenced from the SCSI connector.

Figure 1-23 Cable Connector Pins

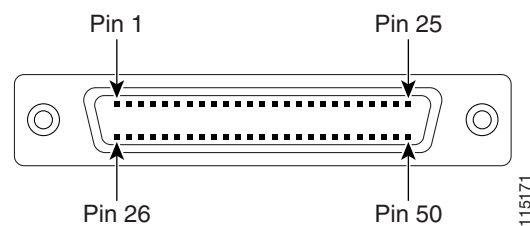

[Table 1-16](#) identifies the UBIC-V SCSI connector pin assignments for the DS-1 cables as referenced from the EIA backplane to the SCSI connector.



Note

Conversion from the back plane's single ended (unbalanced) 75-ohm signal to a differential (balanced) 100-ohm signal happens through the embedded transformer within the SCSI connector. The cable's shield is connected to the connector shell. This conversion is illustrated in [Figure 1-24](#).

Table 1-16 UBIC-V DS-1 SCSI Connector Pin Out

Port	SCSI Pin	SCSI Pin	Port
#1	1	26	#7
FGnd	2	27	FGnd
FGnd	3	28	FGnd
FGnd	4	29	FGnd
#2	5	30	#8
FGnd	6	31	FGnd
FGnd	7	32	FGnd
FGnd	8	33	FGnd
#3	9	34	#9
FGnd	10	35	FGnd
FGnd	11	36	FGnd
FGnd	12	37	FGnd
#4	13	38	#10
FGnd	14	39	FGnd
FGnd	15	40	FGnd
FGnd	16	41	FGnd
#5	17	42	#11
FGnd	18	43	FGnd
FGnd	19	44	FGnd
FGnd	20	45	FGnd
#6	21	46	#12
FGnd	22	47	FGnd
FGnd	23	48	FGnd
FGnd	24	49	FGnd
#13	25	50	#14

Figure 1-24 UBIC-V DS-1 Cable Schematic Diagram

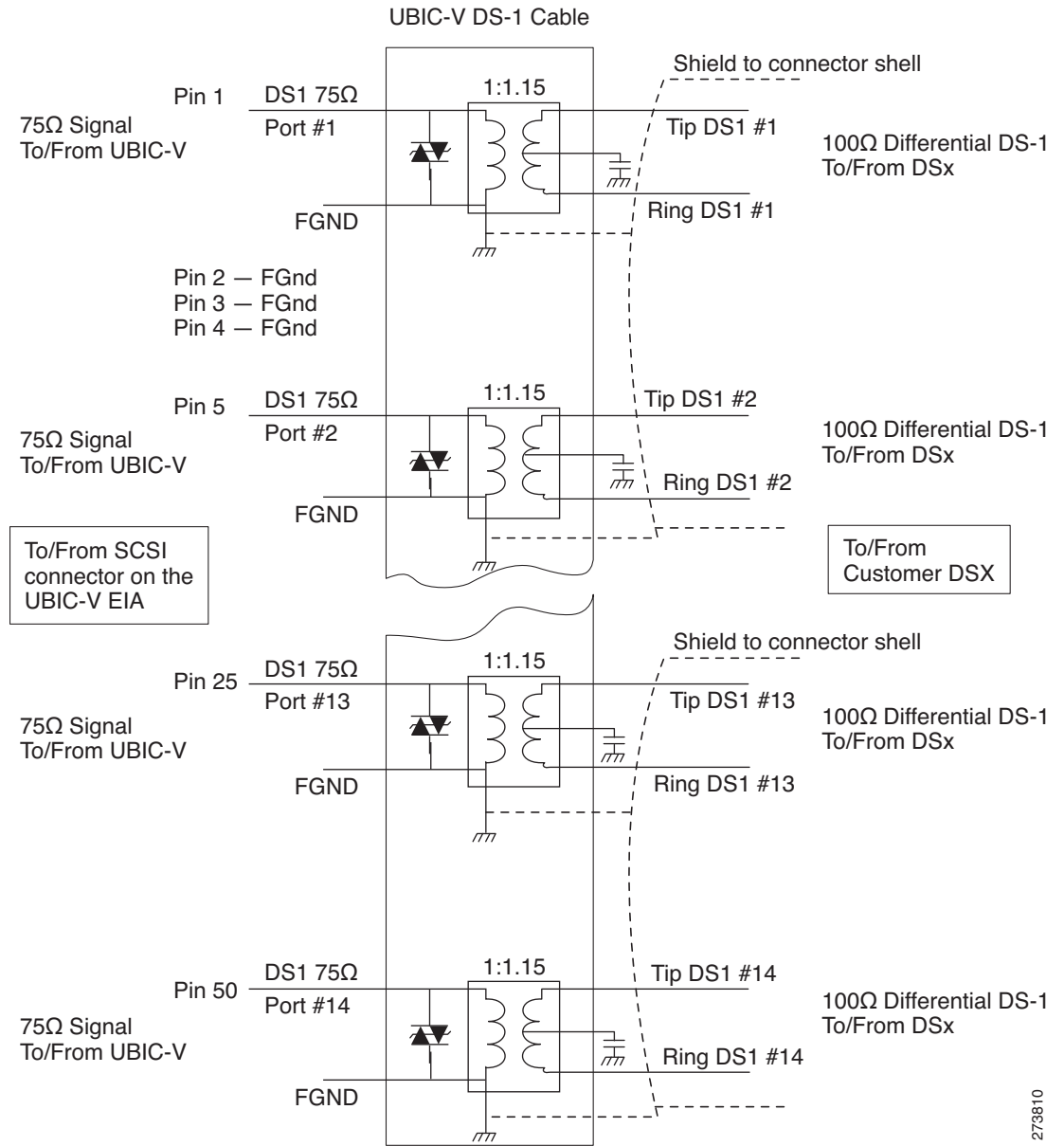

Table 1-17 shows the UBIC-V DS-1 Tip/Ring color coding.

Table 1-17 UBIC-V DS-1 Tip/Ring Color Coding

Wire Color	Signal	Signal	Wire Color
White/blue	Tip DS-1 #1	Ring DS-1 #1	Blue/white
White/orange	Tip DS-1 #2	Ring DS-1 #2	Orange/white
White/green	Tip DS-1 #3	Ring DS-1 #3	Green/white
White/brown	Tip DS-1 #4	Ring DS-1 #4	Brown/white
White/slate	Tip DS-1 #5	Ring DS-1 #5	Slate/white
Red/blue	Tip DS-1 #6	Ring DS-1 #6	Blue/red
Red/orange	Tip DS-1 #7	Ring DS-1 #7	Orange/red
Red/green	Tip DS-1 #8	Ring DS-1 #8	Green/red
Red/brown	Tip DS-1 #9	Ring DS-1 #9	Brown/red
Red/slate	Tip DS-1 #10	Ring DS-1 #10	Slate/red
Black/blue	Tip DS-1 #11	Ring DS-1 #11	Blue/black
Black/orange	Tip DS-1 #12	Ring DS-1 #12	Orange/black
Black/green	Tip DS-1 #13	Ring DS-1 #13	Green/black
Black/brown	Tip DS-1 #14	Ring DS-1 #14	Brown/black

Table 1-18 identifies the UBIC-V SCSI connector pin assignments for the DS-3/EC-1 cables as referenced from the EIA backplane to the SCSI connector.

Table 1-18 UBIC-V DS-3/EC-1 SCSI Connector Pin Out

Port	SCSI Pin	SCSI Pin	Port
#1	1	26	#7
FGnd	2	27	FGnd
FGnd	3	28	FGnd
FGnd	4	29	FGnd
#2	5	30	#8
FGnd	6	31	FGnd
FGnd	7	32	FGnd
FGnd	8	33	FGnd
#3	9	34	#9
FGnd	10	35	FGnd
FGnd	11	36	FGnd
FGnd	12	37	FGnd
#4	13	38	#10
FGnd	14	39	FGnd
FGnd	15	40	FGnd
FGnd	16	41	FGnd

Table 1-18 *UBIC-V DS-3/EC-1 SCSI Connector Pin Out (continued)*

Port	SCSI Pin	SCSI Pin	Port
#5	17	42	#11
FGnd	18	43	FGnd
FGnd	19	44	FGnd
FGnd	20	45	FGnd
#6	21	46	#12
FGnd	22	47	FGnd
FGnd	23	48	FGnd
FGnd	24	49	FGnd
Not connected	25	50	Not connected

Figure 1-25 shows the UBIC-V DS-3/EC-1 cable schematic diagram.

Figure 1-25 UBIC-V DS-3/EC-1 Cable Schematic Diagram

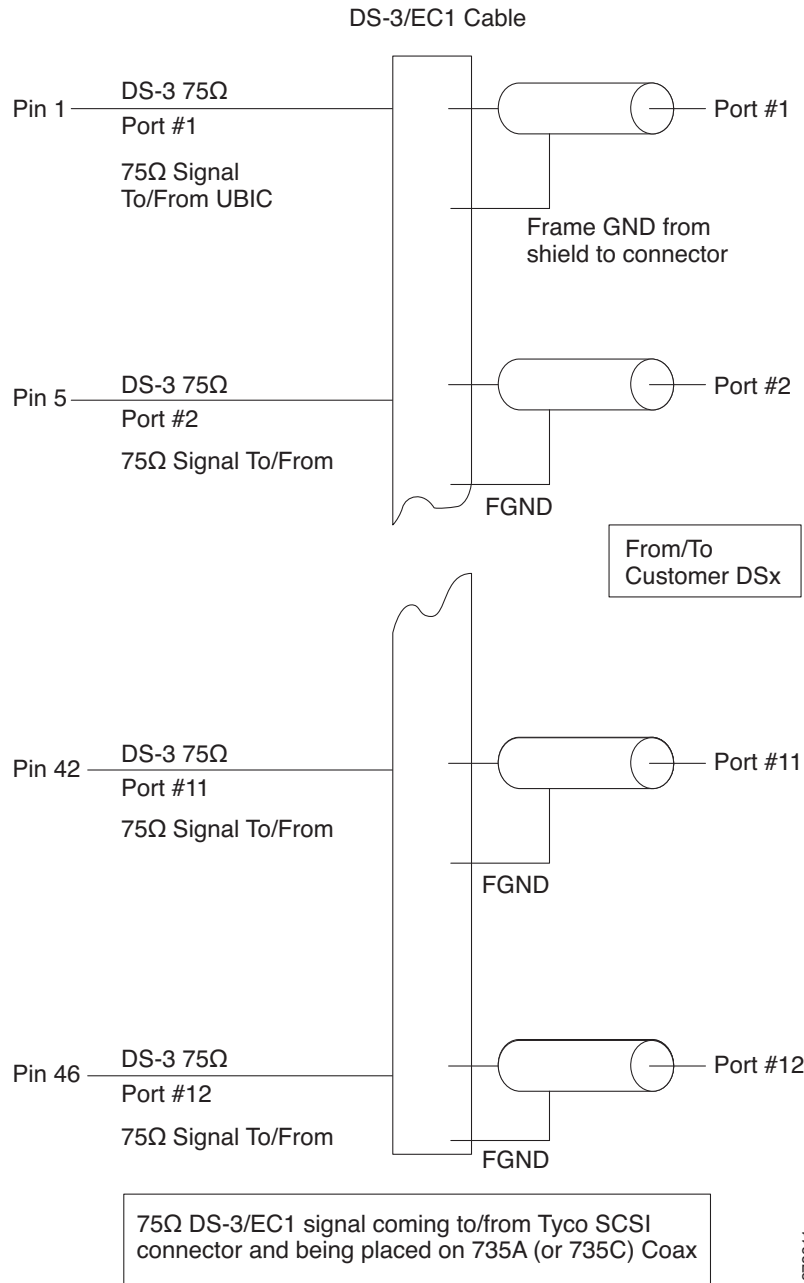

1.9 UBIC-H Cables

The UBIC-H EIA is designed to support DS-1, DS-3, or EC-1 signals. The type of signal supported is determined by the UBIC-H cable assembly that you order.

To support DS-1 signals, select the DS-1 UBIC-H cable assembly (part number 15454-CADS1-H- \langle length \rangle).

To support DS-3 or EC-1 signals, select the DS-3/EC-1 UBIC-H cable assembly (part number 15454-CADS3-H-<length>).

DS-1 cables for the UBIC-H have a maximum supported distance of 655 feet (199.6 m). DS-1 cables arrive with unterminated #24 AWG twisted pairs on the far end and are color coded as identified in [Table 1-20](#).

The following DS-1 cables are available from Cisco Systems for use with the UBIC-H EIA:

- 25 feet: 15454-CADS1-H-25
- 50 feet: 15454-CADS1-H-50
- 75 feet: 15454-CADS1-H-75
- 100 feet: 15454-CADS1-H-100
- 150 feet: 15454-CADS1-H-150
- 200 feet: 15454-CADS1-H-200
- 250 feet: 15454-CADS1-H-250
- 350 feet: 15454-CADS1-H-350
- 450 feet: 15454-CADS1-H-450
- 550 feet: 15454-CADS1-H-550
- 655 feet: 15454-CADS1-H-655

DS-3/EC-1 cables for the UBIC-H have a maximum supported distance of 450 feet (137.2 m).

DS-3/EC-1 cables arrive with unterminated coaxial cable at the far end and labeled with the respective port number. 75-ohm BNC connectors for each port (qty. 12) are supplied and require that they be crimped on.

The following DS-3/EC-1 cables are available from Cisco Systems for use with the UBIC-H EIA:

- 25 feet: 15454-CADS3-H-25
- 50 feet: 15454-CADS3-H-50
- 75 feet: 15454-CADS3-H-75
- 100 feet: 15454-CADS3-H-100
- 125 feet: 15454-CADS3-H-125
- 150 feet: 15454-CADS3-H-150
- 175 feet: 15454-CADS3-H-175
- 200 feet: 15454-CADS3-H-200
- 225 feet: 15454-CADS3-H-225
- 250 feet: 15454-CADS3-H-250
- 300 feet: 15454-CADS3-H-300
- 350 feet: 15454-CADS3-H-350
- 450 feet: 15454-CADS3-H-450

[Figure 1-26](#) identifies the pin numbers for the DS-1 and DS-3/EC-1 cables as referenced from the SCSI connector.

Figure 1-26 Cable Connector Pins

Table 1-19 identifies the UBIC-H SCSI connector pin assignments for the DS-1 cables as referenced from the EIA backplane to the SCSI connector.

**Note**

Conversion from the back plane's single ended (unbalanced) 75-ohm signal to a differential (balanced) 100-ohm signal happens through the embedded transformer within the SCSI connector. The cable's shield is connected to the connector shell. This conversion is illustrated in Figure 1-27.

Table 1-19 UBIC-H DS-1 SCSI Connector Pin Out

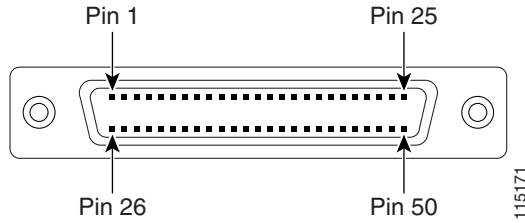
Port	SCSI Pin	SCSI Pin	Port
#1	1	26	#7
FGnd	2	27	FGnd
FGnd	3	28	FGnd
FGnd	4	29	FGnd
#2	5	30	#8
FGnd	6	31	FGnd
FGnd	7	32	FGnd
FGnd	8	33	FGnd
#3	9	34	#9
FGnd	10	35	FGnd
FGnd	11	36	FGnd
FGnd	12	37	FGnd
#4	13	38	#10
FGnd	14	39	FGnd
FGnd	15	40	FGnd
FGnd	16	41	FGnd
#5	17	42	#11
FGnd	18	43	FGnd
FGnd	19	44	FGnd
FGnd	20	45	FGnd
#6	21	46	#12
FGnd	22	47	FGnd

Table 1-19 UBIC-H DS-1 SCSI Connector Pin Out (continued)

Port	SCSI Pin	SCSI Pin	Port
FGnd	23	48	FGnd
FGnd	24	49	FGnd
#13	25	50	#14

Figure 1-27 UBIC-H DS-1 Cable Schematic Diagram

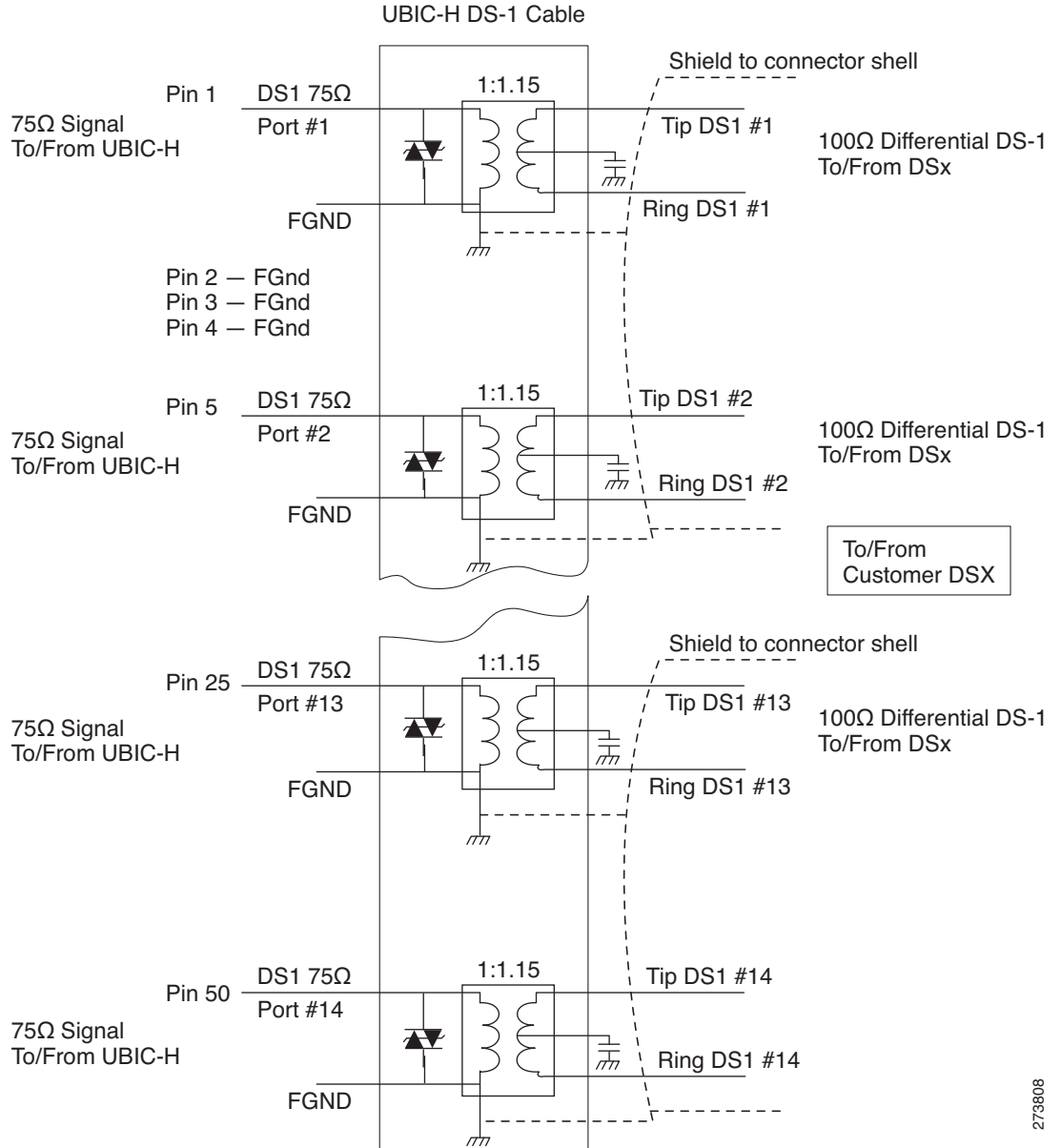

Table 1-20 shows the UBIC-H DS-1 Tip/Ring color coding.

273808

Table 1-20 UBIC-H DS-1 Tip/Ring Color Coding

Wire Color	Signal	Signal	Wire Color
White/blue	Tip DS-1 #1	Ring DS-1 #1	Blue/white
White/orange	Tip DS-1 #2	Ring DS-1 #2	Orange/white
White/green	Tip DS-1 #3	Ring DS-1 #3	Green/white
White/brown	Tip DS-1 #4	Ring DS-1 #4	Brown/white
White/slate	Tip DS-1 #5	Ring DS-1 #5	Slate/white
Red/blue	Tip DS-1 #6	Ring DS-1 #6	Blue/red
Red/orange	Tip DS-1 #7	Ring DS-1 #7	Orange/red
Red/green	Tip DS-1 #8	Ring DS-1 #8	Green/red
Red/brown	Tip DS-1 #9	Ring DS-1 #9	Brown/red
Red/slate	Tip DS-1 #10	Ring DS-1 #10	Slate/red
Black/blue	Tip DS-1 #11	Ring DS-1 #11	Blue/black
Black/orange	Tip DS-1 #12	Ring DS-1 #12	Orange/black
Black/green	Tip DS-1 #13	Ring DS-1 #13	Green/black
Black/brown	Tip DS-1 #14	Ring DS-1 #14	Brown/black

Table 1-21 identifies the UBIC-H SCSI connector pin assignments for the DS-3/EC-1 cables as referenced from the EIA backplane to the SCSI connector.

Table 1-21 UBIC-H DS-3/EC-1 SCSI Connector Pin Out

Port	SCSI Pin	SCSI Pin	Port
#1	1	26	#7
FGnd	2	27	FGnd
FGnd	3	28	FGnd
FGnd	4	29	FGnd
#2	5	30	#8
FGnd	6	31	FGnd
FGnd	7	32	FGnd
FGnd	8	33	FGnd
#3	9	34	#9
FGnd	10	35	FGnd
FGnd	11	36	FGnd
FGnd	12	37	FGnd
#4	13	38	#10
FGnd	14	39	FGnd
FGnd	15	40	FGnd
FGnd	16	41	FGnd

Table 1-21 *UBIC-H DS-3/EC-1 SCSI Connector Pin Out (continued)*

Port	SCSI Pin	SCSI Pin	Port
#5	17	42	#11
FGnd	18	43	FGnd
FGnd	19	44	FGnd
FGnd	20	45	FGnd
#6	21	46	#12
FGnd	22	47	FGnd
FGnd	23	48	FGnd
FGnd	24	49	FGnd
Not connected	25	50	Not connected

Figure 1-28 shows the UBIC-H DS-3/EC-1 cable schematic diagram

Figure 1-28 UBIC-H DS-3/EC-1 Cable Schematic Diagram

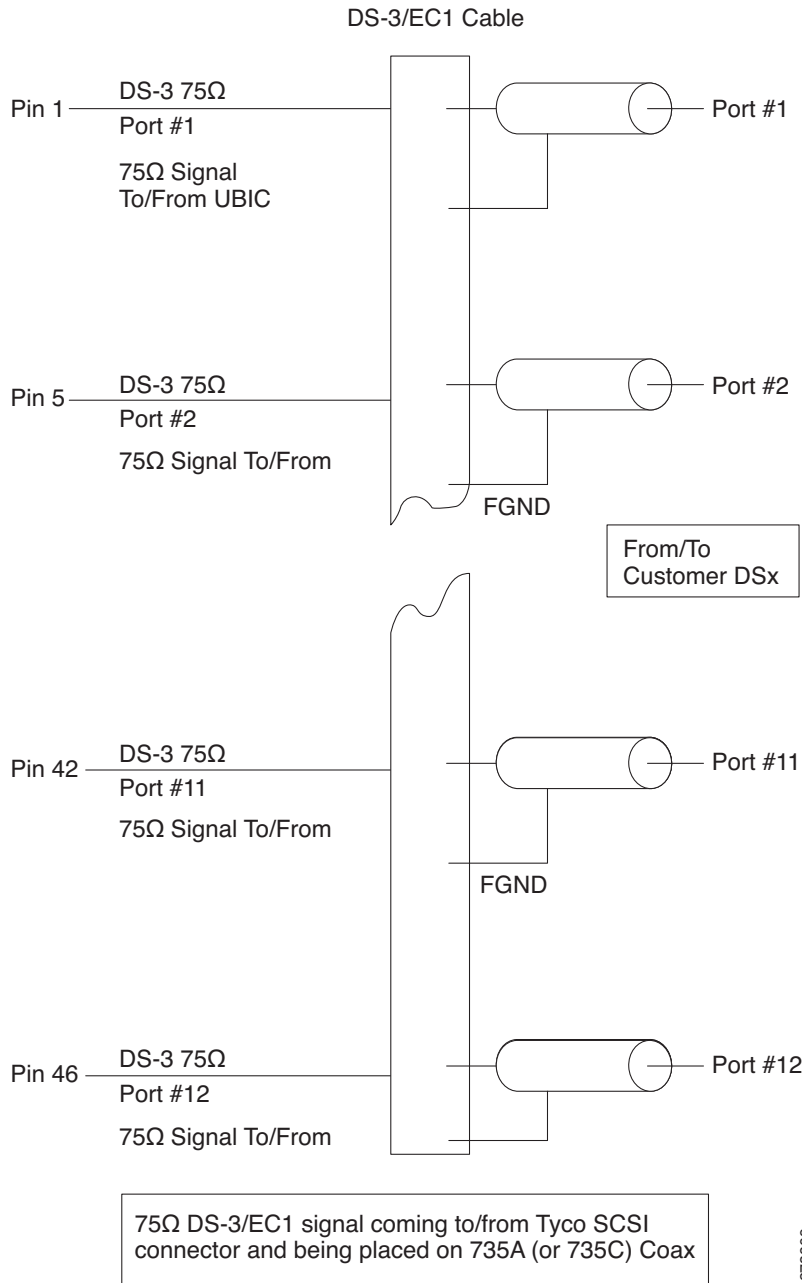

1.10 Ethernet Cables

Ethernet cables use RJ-45 connectors, and are straight-through or crossover, depending on what is connected to them.

[Table 1-22](#) shows 100Base-TX connector pin assignments, used with E100 Ethernet cards in the ONS 15454.

Table 1-22 E100-TX Connector Pinout

Pin	Cable Port
1	RD+
2	RD-
3	TD+
4	NC
5	NC
6	TD-
7	NC
8	NC

Figure 1-29 shows the pin locations on 100BaseT connector.

Figure 1-29 100BaseT Connector Pins

Figure 1-30 shows the straight-through Ethernet cable schematic. Use a straight-through cable when connecting to a router or a PC.

Figure 1-30 Straight-Through Cable

Figure 1-31 shows the crossover Ethernet cable schematic. Use a crossover cable when connecting to a switch or hub.

Figure 1-31 Crossover Cable

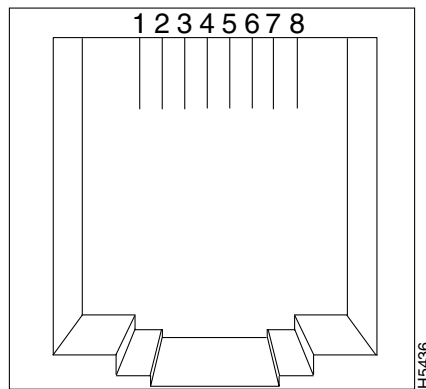

1.11 Cable Routing and Management

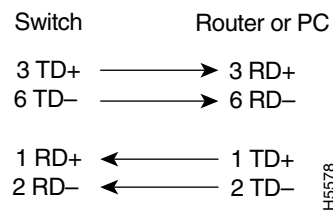
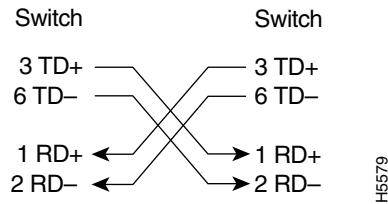
The ONS 15454 cable management facilities include the following:

- A cable-routing channel (behind the fold-down door) that runs the width of the shelf assembly (Figure 1-32)
- Plastic horseshoe-shaped fiber guides at each side opening of the cable-routing channel that ensure the proper bend radius is maintained in the fibers (Figure 1-33)



Note You can remove the fiber guide if necessary to create a larger opening (if you need to route CAT-5 Ethernet cables out the side, for example). To remove the fiber guide, take out the three screws that anchor it to the side of the shelf assembly.

- A fold-down door that provides access to the cable-management tray
- Cable tie-wrap facilities on EIAs that secure cables to the cover panel
- A cable routing channel that enables you to route cables out either side
- Jumper slack storage reels (2) on each side panel that reduce the amount of slack in cables that are connected to other devices



Note To remove the jumper slack storage reels, take out the screw in the center of each reel.

- Optional tie-down bar

Figure 1-32 shows the cable management facilities that you can access through the fold-down front door, including the cable-routing channel and cable-routing channel posts.

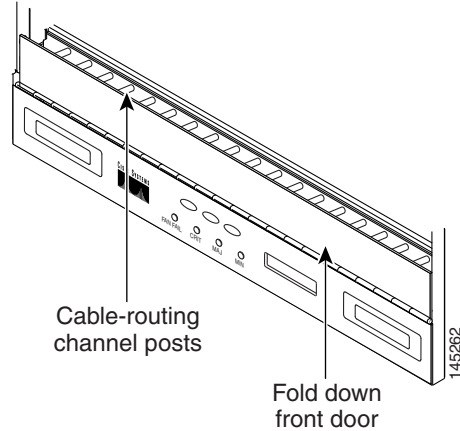
Figure 1-32 Managing Cables on the Front Panel

1.11.1 Fiber Management

The jumper routing fins are designed to route fiber jumpers out of both sides of the shelf. Slots 1 to 6 exit to the left, and Slots 12 to 17 exit to the right. [Figure 1-33](#) shows fibers routed from cards in the left slots, down through the fins, then exiting out the fiber channel to the left. The maximum capacity of the fiber routing channel depends on the size of the fiber jumpers. [Table 1-23](#) gives the maximum capacity of the fiber channel for each side of the shelf, for the different fiber sizes.

Figure 1-33 Fiber Capacity

Table 1-23 provides the maximum capacity of the fiber channel for one side of a shelf, depending on fiber size and number of Ethernet cables running through that fiber channel.

Table 1-23 Fiber Channel Capacity (One Side of the Shelf)

Fiber Diameter	Maximum Number of Fibers Exiting Each Side		
	No Ethernet Cables	One Ethernet Cable	Two Ethernet Cables
1.6 mm (0.6 inch)	144	127	110
2 mm (0.7 inch)	90	80	70
3 mm (0.11 inch)	40	36	32

Plan your fiber size according to the number of cards/ports installed in each side of the shelf. For example, if your port combination requires 36 fibers, 3 mm (0.11 inch) fiber is adequate. If your port combination requires 68 fibers, you must use 2 mm(0.7 inch) or smaller fibers.

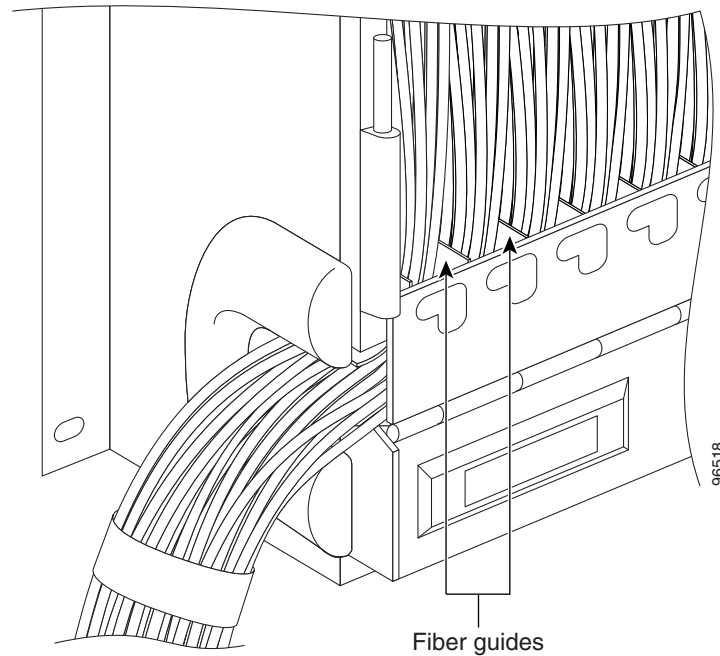
1.11.2 Fiber Management Using the Tie-Down Bar

You can install an optional 5-inch (127 mm) tie-down bar on the rear of the ANSI chassis. You can use tie-wraps or other site-specific material to bundle the cabling and attach it to the bar so that you can more easily route the cable away from the rack.

Figure 1-34 shows the tie-down bar, the ONS 15454, and the rack.

Figure 1-34 Tie-Down Bar

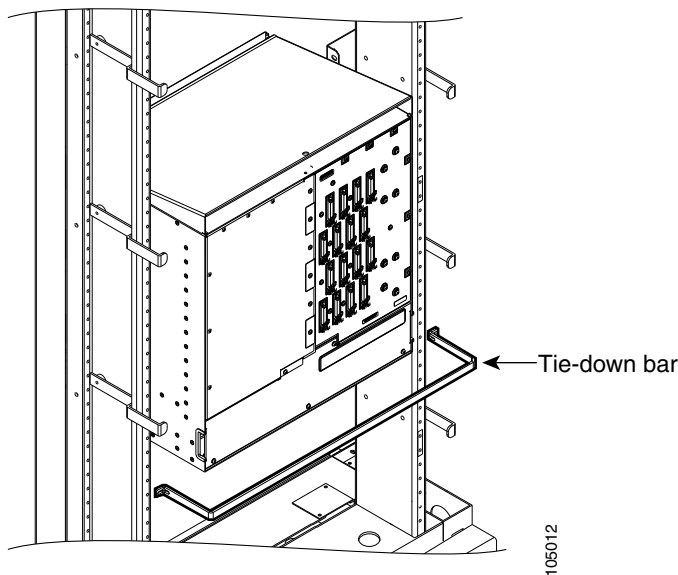

1.11.3 Coaxial Cable Management

Coaxial cables connect to EIAs on the ONS 15454 backplane using cable connectors. EIAs feature cable-management eyelets for tie wrapping or lacing cables to the cover panel.

1.11.4 DS-1 Twisted-Pair Cable Management

Connect twisted pair/DS-1 cables to SMB EIAs on the ONS 15454 backplane using cable connectors and DS-1 EIAs (baluns).

1.11.5 AMP Champ Cable Management

EIAs have cable management eyelets to tiwrap or lace cables to the cover panel. Tie wrap or lace the AMP Champ cables according to local site practice and route the cables. If you configure the ONS 15454 for a 23-inch (584.2 mm) rack, two additional inches (50.8 mm) of cable management area is available on each side of the shelf assembly.

1.12 Alarm Expansion Panel

The optional ONS 15454 alarm expansion panel (AEP) can be used with the Alarm Interface Controller—International card (AIC-I) card to provide an additional 48 dry alarm contacts for the ONS 15454, 32 of which are inputs and 16 are outputs. The AEP is a printed circuit board assembly that is installed on the backplane. [Figure 1-35](#) shows the AEP board; the left connector is the input connector and the right connector is the output connector.

The AIC-I without an AEP already contains direct alarm contacts. These direct AIC-I alarm contacts are routed through the backplane to wire-wrap pins accessible from the back of the shelf. If you install an AEP, you cannot use the alarm contacts on the wire-wrap pins. For further information about the AIC-I, see the [“2.7 AIC-I Card”](#) section on page 2-27.

Figure 1-35 AEP Printed Circuit Board Assembly

Figure 1-36 shows the AEP block diagram.

Figure 1-36 AEP Block Diagram

Each AEP alarm input port has provisionable label and severity. The alarm inputs have optocoupler isolation. They have one common 48-VDC output and a maximum of 2 mA per input. Each opto metal oxide semiconductor (MOS) alarm output can operate by definable alarm condition, a maximum open circuit voltage of 60 VDC, and a maximum current of 100 mA. See the “[2.7.2 External Alarms and Controls](#)” section on [page 2-29](#) for further information.

1.12.1 Wire-Wrap and Pin Connections

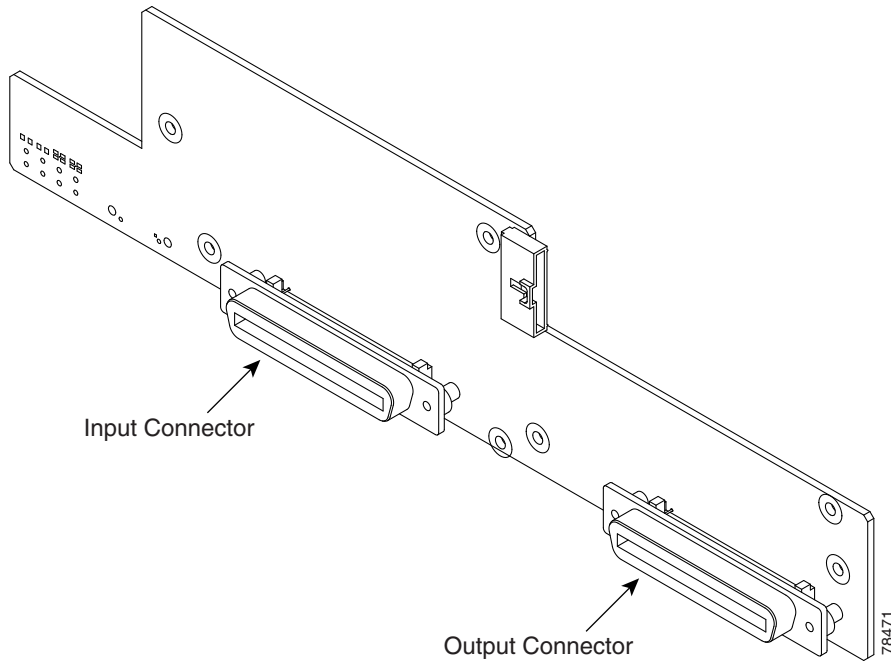
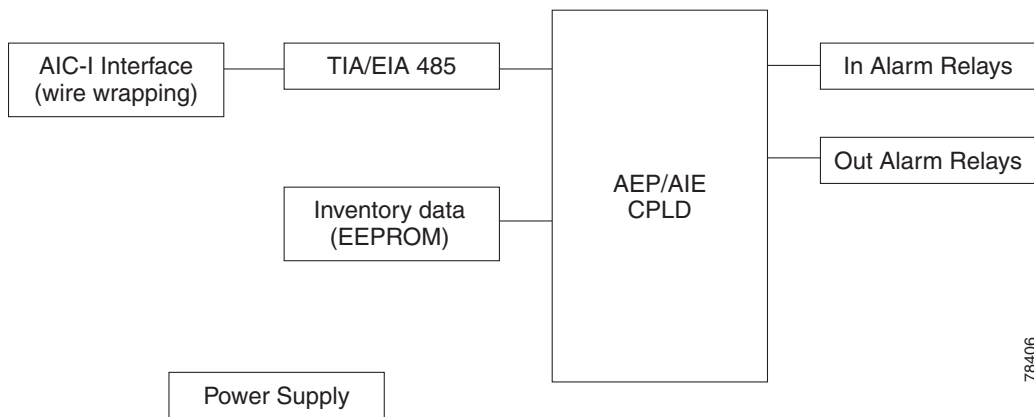
Figure 1-37 shows the wire-wrapping connections on the backplane.

Figure 1-37 AEP Wire-Wrap Connections to Backplane Pins

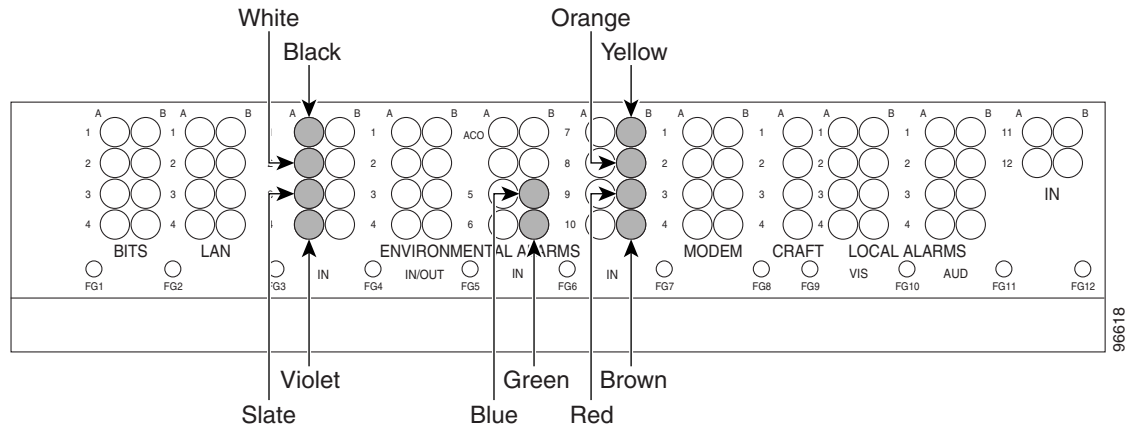

Table 1-24 shows the backplane pin assignments and corresponding signals on the AIC-I and AEP.

Table 1-24 Pin Assignments for the AEP

AEP Cable Wire	Backplane Pin	AIC-I Signal	AEP Signal
Black	A1	GND	AEP_GND
White	A2	AE_+5	AEP_+5
Slate	A3	VBAT-	VBAT-
Violet	A4	VB+	VB+
Blue	A5	AE_CLK_P	AE_CLK_P
Green	A6	AE_CLK_N	AE_CLK_N
Yellow	A7	AE_DIN_P	AE_DOUT_P
Orange	A8	AE_DIN_N	AE_DOUT_N
Red	A9	AE_DOUT_P	AE_DIN_P
Brown	A10	AE_DOUT_N	AE_DIN_N

Figure 1-38 is a circuit diagram of the alarm inputs (Inputs 1 and 32 are shown in the example).

Figure 1-38 Alarm Input Circuit Diagram

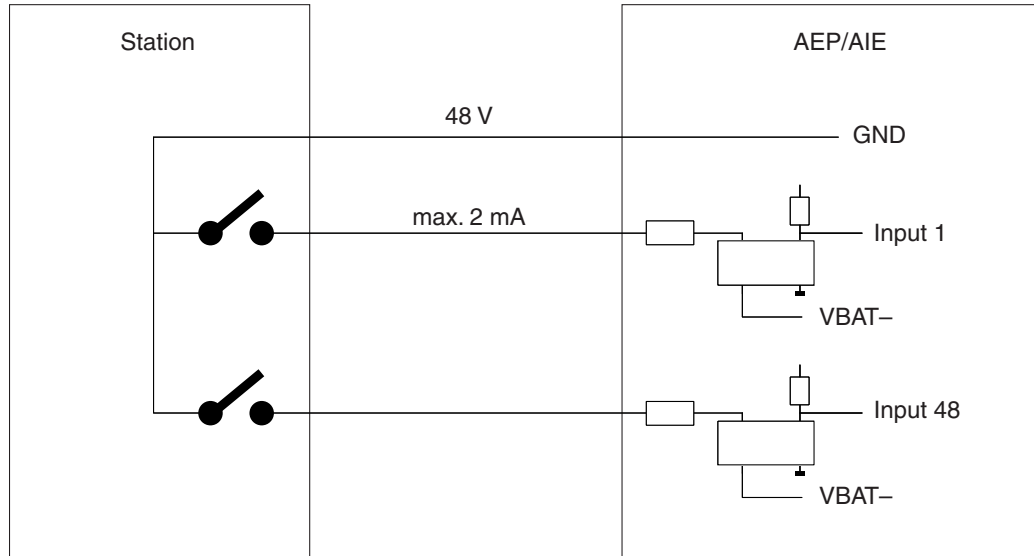

Table 1-25 lists the connections to the external alarm sources.

Table 1-25 Alarm Input Pin Association

AMP Champ Pin Number	Signal Name	AMP Champ Pin Number	Signal Name
1	ALARM_IN_1-	27	GND
2	GND	28	ALARM_IN_2-
3	ALARM_IN_3-	29	ALARM_IN_4-
4	ALARM_IN_5-	30	GND
5	GND	31	ALARM_IN_6-
6	ALARM_IN_7-	32	ALARM_IN_8-
7	ALARM_IN_9-	33	GND
8	GND	34	ALARM_IN_10-
9	ALARM_IN_11-	35	ALARM_IN_12-
10	ALARM_IN_13-	36	GND
11	GND	37	ALARM_IN_14-
12	ALARM_IN_15-	38	ALARM_IN_16-
13	ALARM_IN_17-	39	GND
14	GND	40	ALARM_IN_18-
15	ALARM_IN_19-	41	ALARM_IN_20-
16	ALARM_IN_21-	42	GND
17	GND	43	ALARM_IN_22-
18	ALARM_IN_23-	44	ALARM_IN_24-
19	ALARM_IN_25-	45	GND

Table 1-25 Alarm Input Pin Association (continued)

AMP Champ Pin Number	Signal Name	AMP Champ Pin Number	Signal Name
20	GND	46	ALARM_IN_26-
21	ALARM_IN_27-	47	ALARM_IN_28-
22	ALARM_IN_29-	48	GND
23	GND	49	ALARM_IN_30-
24	ALARM_IN_31-	50	N.C.
25	ALARM_IN_+	51	GND1
26	ALARM_IN_0-	52	GND2

Figure 1-39 is a circuit diagram of the alarm outputs (Outputs 1 and 16 are shown in the example).

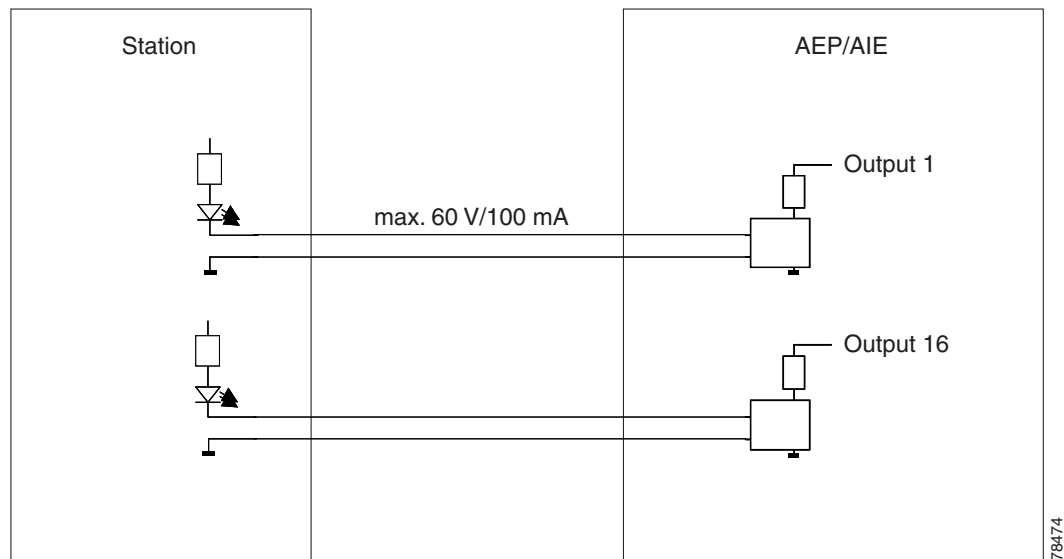
Figure 1-39 Alarm Output Circuit Diagram

Use the pin numbers in Table 1-26 to connect to the external elements being switched by external alarms.

Table 1-26 Pin Association for Alarm Output Pins

AMP Champ Pin Number	Signal Name	AMP Champ Pin Number	Signal Name
1	N.C.	27	COM_0
2	COM_1	28	N.C.
3	NO_1	29	NO_2
4	N.C.	30	COM_2
5	COM_3	31	N.C.
6	NO_3	32	NO_4

Table 1-26 Pin Association for Alarm Output Pins (continued)

AMP Champ Pin Number	Signal Name	AMP Champ Pin Number	Signal Name
7	N.C.	33	COM_4
8	COM_5	34	N.C.
9	NO_5	35	NO_6
10	N.C.	36	COM_6
11	COM_7	37	N.C.
12	NO_7	38	NO_8
13	N.C.	39	COM_8
14	COM_9	40	N.C.
15	NO_9	41	NO_10
16	N.C.	42	COM_10
17	COM_11	43	N.C.
18	NO_11	44	NO_12
19	N.C.	45	COM_12
20	COM_13	46	N.C.
21	NO_13	47	NO_14
22	N.C.	48	COM_14
23	COM_15	49	N.C.
24	NO_15	50	N.C.
25	N.C.	51	GND1
26	NO_0	52	GND2

1.13 Filler Card

Filler cards are designed to occupy empty multiservice and AIC-I slots in the Cisco ONS 15454 (Slots 1–6, 9, and 12 – 17). The filler card cannot operate in the XC slots (Slots 8 and 10) or TCC slots (7 and 11). When installed, the filler card aids in maintaining proper air flow and EMI requirements.



Note

There are two types of filler cards, a detectable version (Cisco P/N 15454-FILLER) and a non-detectable version (Cisco P/N 15454-BLANK). The detectable card has the label FILLER on the faceplate. The non-detectable card has no faceplate label. In Software Release 6.0 and greater, the former card is detectable through CTC when installed in the ONS 15454 shelf.

Figure 1-40 shows the faceplate of the detectable filler card. The filler cards have no card-level LED indicators.

Figure 1-40 Detectable Filler Card Faceplate

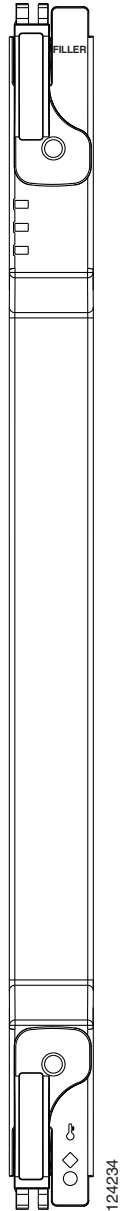

1.14 Fan-Tray Assembly

The fan-tray assembly is located at the bottom of the ONS 15454 bay assembly. The fan tray is a removable drawer that holds fans and fan-control circuitry for the ONS 15454. The front door can be left in place or removed before installing the fan-tray assembly. After you install the fan tray, you should only need to access it if a fan failure occurs or if you need to replace or clean the fan-tray air filter.

The front of the fan-tray assembly has an LCD screen that provides slot- and port-level information for all ONS 15454 card slots, including the number of Critical, Major, and Minor alarms. For optical cards, you can use the LCD to determine if a port is in working or protect mode and is active or standby. The LCD also tells you whether the software load is SONET or SDH and the software version number.

**Note**

The 15454-SA-ANSI or 15454-SA-HD shelf assembly and 15454-FTA3 fan-tray assembly are required with any ONS 15454 that has XC10G or XC-VXC-10G cards.

**Caution**

The 15454-FTA3-T fan-tray assembly can only be installed in ONS 15454 Release 3.1 and later shelf assemblies (15454-SA-ANSI, P/N: 800-19857; 15454-SA-HD, P/N: 800-24848). The fan-tray assembly has a pin that prevents it from being installed in ONS 15454 shelf assemblies released before ONS 15454 Release 3.1 (15454-SA-NEBS3E, 15454-SA-NEBS3, and 15454-SA-R1, P/N: 800-07149). Equipment damage can result from attempting to install the 15454-FTA3 in a noncompatible shelf assembly.

**Note**

The 15454-FTA3 is not I-temp compliant. To obtain an I-temp fan tray, install the 15454-FTA3-T fan-tray assembly in an ONS 15454 Release 3.1 shelf assembly (15454-SA-ANSI or 15454-SA-HD). However, do not install the ONS 15454 XC10G cross-connect cards with the 15454-FTA2 fan-tray assembly.

1.14.1 Fan Speed and Power Requirements

Fan speed is controlled by TCC2/TCC2P card temperature sensors. The sensors measure the input air temperature at the fan-tray assembly. Fan speed options are low, medium, and high. If the TCC2/TCC2P card fails, the fans automatically shift to high speed. The temperature measured by the TCC/TCC2P2 sensors is displayed on the LCD screen.

[Table 1-27](#) lists power requirements for the fan-tray assembly.

Table 1-27 Fan Tray Assembly Power Requirements

Fan Tray Assembly	Watts	Amps	BTU/Hr
FTA2	53	1.21	198
FTA3 -T	86.4	1.8	295

1.14.2 Fan Failure

If one or more fans fail on the fan-tray assembly, replace the entire assembly. You cannot replace individual fans. The red Fan Fail LED on the front of the fan tray illuminates when one or more fans fail. For fan tray replacement instructions, refer to the *Cisco ONS 15454 Troubleshooting Guide*. The red Fan Fail LED clears after you install a working fan tray.

1.14.3 Air Filter

The ONS 15454 contains a reusable air filter; Model 15454-FTF2, that is installed either beneath the fan-tray assembly or in the optional external filter brackets. Earlier versions of the ONS 15454 used a disposable air filter that is installed beneath the fan-tray assembly only. However, the reusable air filter is backward compatible.

The reusable filter is made of a gray, open-cell, polyurethane foam that is specially coated to provide fire and fungi resistance. All versions of the ONS 15454 can use the reusable air filter. Spare filters should be kept in stock.



Caution

Do not operate an ONS 15454 without the mandatory fan-tray air filter.



Caution

Inspect the air filter every 30 days, and clean the filter every three to six months. Replace the air filter every two to three years. Avoid cleaning the air filter with harsh cleaning agents or solvents. Refer to the *Cisco ONS 15454 Troubleshooting Guide* for information about cleaning and maintaining the fan-tray air filter.

1.15 Power and Ground Description

Ground the equipment according to Telcordia standards or local practices.

Cisco recommends the following wiring conventions, but customer conventions prevail:

- Red wire for battery connections (–48 VDC)
- Black wire for battery return connections (0 VDC)
- The battery return connection is treated as DC-I, as defined in GR-1089-CORE, issue 3.

The ONS 15454 has redundant –48 VDC #8 power terminals on the shelf-assembly backplane. The terminals are labeled BAT1, RET1, BAT2, and RET2 and are located on the lower section of the backplane behind a clear plastic cover.

To install redundant power feeds, use four power cables and one ground cable. For a single power feed, only two power cables (#10 AWG, 2.588 mm² [0.1018 inch], copper conductor, 194°F [90°C]) and one ground cable (#6 AWG, 4.115 mm² [0.162 inch]) are required. Use a conductor with low impedance to ensure circuit overcurrent protection. However, the conductor must have the capability to safely conduct any faulty current that might be imposed.

The existing ground post is a #10-32 bolt. The nut provided for a field connection is also a #10 AWG (2.588 mm² [0.1018 inch]), with an integral lock washer. The lug must be a dual-hole type and rated to accept the #6 AWG (4.115 mm² [0.162 inch]) cable. Two posts are provided on the Cisco ONS 15454 to accommodate the dual-hole lug. [Figure 1-41](#) shows the location of the ground posts.

Figure 1-41 Ground Posts on the ONS 15454 Backplane

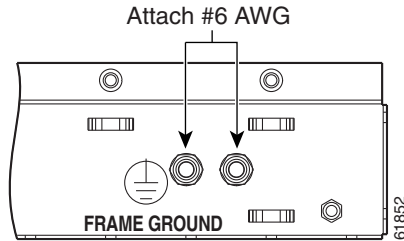

1.16 Alarm, Timing, LAN, and Craft Pin Connections



Caution

Always use the supplied ESD wristband when working with a powered ONS 15454. Plug the wristband cable into the ESD jack located on the lower-right outside edge of the shelf assembly.

The ONS 15454 has a backplane pin field located at the bottom of the backplane. The backplane pin field provides 0.045 square inch (29 mm²) wire-wrap pins for enabling external alarms, timing input and output, and craft interface terminals. This section describes the backplane pin field and the pin assignments for the field. [Figure 1-42](#) shows the wire-wrap pins on the backplane pin field. Beneath each wire-wrap pin is a frame ground pin. Frame ground pins are labeled FG1, FG2, FG3, etc. Install the ground shield of the cables connected to the backplane to the ground pin that corresponds to the pin field used.



Note

The AIC-I requires a shelf assembly running Software Release 3.4.0 or later. The backplane of the ANSI shelf contains a wire-wrap field with pin assignment according to the layout in [Figure 1-42](#). The shelf assembly might be an existing shelf that has been upgraded to R3.4 or later. In this case the backplane pin labeling appears as indicated in [Figure 1-43](#) on [page 1-66](#). But you must use the pin assignments provided by the AIC-I as shown in [Figure 1-42](#).

Figure 1-42 ONS 15454 Backplane Pinouts (Release 3.4 or Later)

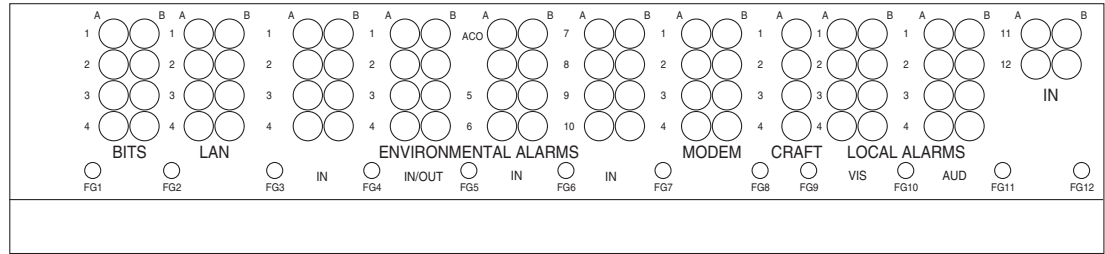

Field	Pin	Function	Field	Pin	Function
BITS	A1	BITS Output 2 negative (-)	ENVIR ALARMS IN/OUT	A1/A13	Normally open output pair number 1
	B1	BITS Output 2 positive (+)		B1/B13	
	A2	BITS Input 2 negative (-)		A2/A14	Normally open output pair number 2
	B2	BITS Input 2 positive (+)		B2/B14	
	A3	BITS Output 1 negative (-)	N/O	A3/A15	Normally open output pair number 3
	B3	BITS Output 1 positive (+)		B3/B15	
	A4	BITS Input 1 negative (-)		A4/A16	Normally open output pair number 4
	B4	BITS Input 1 positive (+)		B4/B16	
LAN	Connecting to a hub, or switch		ACO	A1	Normally open ACO pair
	A1	RJ-45 pin 6 RX-		B1	
	B1	RJ-45 pin 3 RX+	CRAFT	A1	Receive (PC pin #2)
	A2	RJ-45 pin 2 TX-		A2	Transmit (PC pin #3)
	B2	RJ-45 pin 1 TX+		A3	Ground (PC pin #5)
	Connecting to a PC/Workstation or router			A4	DTR (PC pin #4)
	A1	RJ-45 pin 2 RX-	LOCAL ALARMS AUD (Audible)	A1	Alarm output pair number 1: Remote audible alarm.
	B1	RJ-45 pin 1 RX+		B1	
A2	RJ-45 pin 6 TX-	A2		Alarm output pair number 2: Critical audible alarm.	
B2	RJ-45 pin 3 TX+	B2			
ENVIR ALARMS IN	A1	Alarm input pair number 1: Reports closure on connected wires.	N/O	A3	Alarm output pair number 3: Major audible alarm.
	B1	Alarm input pair number 2: Reports closure on connected wires.		B3	Alarm output pair number 3: Major audible alarm.
	A2	Alarm input pair number 2: Reports closure on connected wires.		A4	Alarm output pair number 4: Minor audible alarm.
	B2	Alarm input pair number 2: Reports closure on connected wires.		B4	Alarm output pair number 4: Minor audible alarm.
	A3	Alarm input pair number 3: Reports closure on connected wires.	LOCAL ALARMS VIS (Visual)	A1	Alarm output pair number 1: Remote visual alarm.
	B3	Alarm input pair number 3: Reports closure on connected wires.		B1	
	A4	Alarm input pair number 4: Reports closure on connected wires.		A2	Alarm output pair number 2: Critical visual alarm.
	B4	Alarm input pair number 4: Reports closure on connected wires.		B2	
	A5	Alarm input pair number 5: Reports closure on connected wires.	N/O	A3	Alarm output pair number 3: Major visual alarm.
	B5	Alarm input pair number 5: Reports closure on connected wires.		B3	Alarm output pair number 3: Major visual alarm.
	A6	Alarm input pair number 6: Reports closure on connected wires.		A4	Alarm output pair number 4: Minor visual alarm.
	B6	Alarm input pair number 6: Reports closure on connected wires.		B4	Alarm output pair number 4: Minor visual alarm.
A7	Alarm input pair number 7: Reports closure on connected wires.				
B7	Alarm input pair number 7: Reports closure on connected wires.				
A8	Alarm input pair number 8: Reports closure on connected wires.				
B8	Alarm input pair number 8: Reports closure on connected wires.				
A9	Alarm input pair number 9: Reports closure on connected wires.				
B9	Alarm input pair number 9: Reports closure on connected wires.				
A10	Alarm input pair number 10: Reports closure on connected wires.				
B10	Alarm input pair number 10: Reports closure on connected wires.				
A11	Alarm input pair number 11: Reports closure on connected wires.				
B11	Alarm input pair number 11: Reports closure on connected wires.				
A12	Alarm input pair number 12: Reports closure on connected wires.				
B12	Alarm input pair number 12: Reports closure on connected wires.				

If you are using an AIC-I card, contacts provisioned as OUT are 1-4. Contacts provisioned as IN are 13-16.

83020

Figure 1-43 ONS 15454 Backplane Pinouts

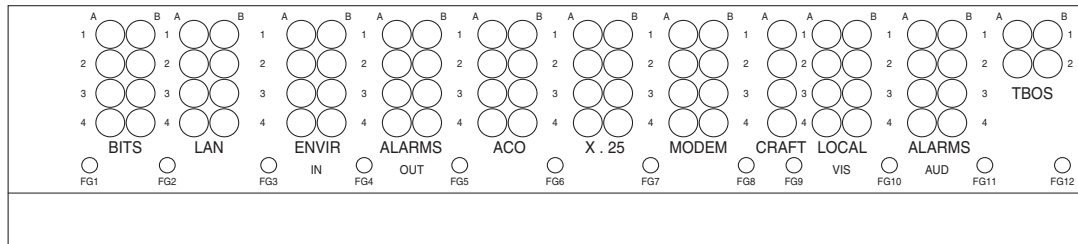

Field	Pin	Function	Field	Pin	Function
BITS	A1	BITS Output 2 negative (-)	ENVIR ALARMS OUT	A1	Normally open output pair number 1
	B1	BITS Output 2 positive (+)		B1	
	A2	BITS Input 2 negative (-)		A2	Normally open output pair number 2
	B2	BITS Input 2 positive (+)		B2	
	A3	BITS Output 1 negative (-)	N/O	A3	Normally open output pair number 3
	B3	BITS Output 1 positive (+)		B3	
	A4	BITS Input 1 negative (-)		A4	Normally open output pair number 4
	B4	BITS Input 1 positive (+)		B4	
LAN	Connecting to a hub, or switch		ACO	A1	Normally open ACO pair
	A1	RJ-45 pin 6 RX-		B1	
	B1	RJ-45 pin 3 RX+	CRAFT	A1	Receive (PC pin #2)
	A2	RJ-45 pin 2 TX-		A2	Transmit (PC pin #3)
	B2	RJ-45 pin 1 TX+		A3	Ground (PC pin #5)
	Connecting to a PC/Workstation or router			A4	DTR (PC pin #4)
	A1	RJ-45 pin 2 RX-	LOCAL ALARMS AUD (Audible)	A1	Alarm output pair number 1: Remote audible alarm.
	B1	RJ-45 pin 1 RX+		B1	
A2	RJ-45 pin 6 TX-	A2		Alarm output pair number 2: Critical audible alarm.	
B2	RJ-45 pin 3 TX+	B2			
ENVIR ALARMS IN	A1	Alarm input pair number 1: Reports closure on connected wires.	N/O	A3	Alarm output pair number 3: Major audible alarm.
	B1	Alarm input pair number 2: Reports closure on connected wires.		B3	
	A2	Alarm input pair number 2: Reports closure on connected wires.		A4	Alarm output pair number 4: Minor audible alarm.
	B2	Alarm input pair number 2: Reports closure on connected wires.		B4	
	A3	Alarm input pair number 3: Reports closure on connected wires.	LOCAL ALARMS VIS (Visual)	A1	Alarm output pair number 1: Remote visual alarm.
	B3	Alarm input pair number 3: Reports closure on connected wires.		B1	
	A4	Alarm input pair number 4: Reports closure on connected wires.		A2	Alarm output pair number 2: Critical visual alarm.
	B4	Alarm input pair number 4: Reports closure on connected wires.		B2	
		N/O	A3	Alarm output pair number 3: Major visual alarm.	
			B3		
			A4	Alarm output pair number 4: Minor visual alarm.	
			B4		

386533

1.16.1 Alarm Contact Connections

The alarm pin field supports up to 17 alarm contacts, including four audible alarms, four visual alarms, one alarm cutoff (ACO), and four user-definable alarm input and output contacts.

Audible alarm contacts are in the LOCAL ALARM AUD pin field and visual contacts are in the LOCAL ALARM VIS pin field. Both of these alarms are in the LOCAL ALARMS category. User-definable contacts are in the ENVIR ALARM IN (external alarm) and ENVIR ALARM OUT (external control) pin fields. These alarms are in the ENVIR ALARMS category; you must have the AIC-I card installed to use the ENVIR ALARMS. Alarm contacts are Normally Open (N/O), meaning that the system closes the alarm contacts when the corresponding alarm conditions are present. Each alarm contact consists of two wire-wrap pins on the shelf assembly backplane. Visual and audible alarm contacts are classified as critical, major, minor, and remote. Figure 1-43 shows alarm pin assignments.

Visual and audible alarms are typically wired to trigger an alarm light or bell at a central alarm collection point when the corresponding contacts are closed. You can use the Alarm Cutoff pins to activate a remote ACO for audible alarms. You can also activate the ACO function by pressing the ACO button on the TCC2/TCC2P card faceplate. The ACO function clears all audible alarm indications. After clearing the audible alarm indication, the alarm is still present and viewable in the Alarms tab in CTC. For more information, see the “2.7.2 External Alarms and Controls” section on page 2-29.

1.16.2 Timing Connections

The ONS 15454 backplane supports two building integrated timing supply (BITS) clock pin fields. The first four BITS pins, rows 3 and 4, support output and input from the first external timing device. The last four BITS pins, rows 1 and 2, perform the identical functions for the second external timing device. [Table 1-28](#) lists the pin assignments for the BITS timing pin fields.



Note

For timing connection, use 100-ohm shielded BITS clock cable pair #22 or #24 AWG (0.51 mm² [0.020 inch] or 0.64 mm² [0.0252 inch]), twisted-pair T1-type.

Table 1-28 BITS External Timing Pin Assignments

External Device	Contact	Tip and Ring	Function
First external device	A3 (BITS 1 Out)	Primary ring (–)	Output to external device
	B3 (BITS 1 Out)	Primary tip (+)	Output to external device
	A4 (BITS 1 In)	Secondary ring (–)	Input from external device
	B4 (BITS 1 In)	Secondary tip (+)	Input from external device
Second external device	A1 (BITS 2 Out)	Primary ring (–)	Output to external device
	B1 (BITS 2 Out)	Primary tip (+)	Output to external device
	A2 (BITS 2 In)	Secondary ring (–)	Input from external device
	B2 (BITS 2 In)	Secondary tip (+)	Input from external device



Note

Refer to Telcordia SR-NWT-002224 for rules about provisioning timing references.

For more information, see [Chapter 10, “Timing.”](#)

1.16.3 LAN Connections

Use the LAN pins on the ONS 15454 backplane to connect the ONS 15454 to a workstation or Ethernet LAN, or to a LAN modem for remote access to the node. You can also use the LAN port on the TCC2/TCC2P card faceplate to connect a workstation or to connect the ONS 15454 to the network. [Table 1-29](#) shows the LAN pin assignments.

Before you can connect an ONS 15454 to other ONS 15454s or to a LAN, you must change the default IP address that is shipped with each ONS 15454 (192.1.0.2).

Table 1-29 LAN Pin Assignments

Pin Field	Backplane Pins	RJ-45 Pins
LAN 1 Connecting to data circuit-terminating equipment (DCE ¹ , a hub or switch)	B2	1
	A2	2
	B1	3
	A1	6
LAN 1 Connecting to data terminal equipment (DTE) (a PC/workstation or router)	B1	1
	A1	2
	B2	3
	A2	6

1. The Cisco ONS 15454 is DCE.

1.16.4 TL1 Craft Interface Installation

You can use the craft pins on the ONS 15454 backplane or the EIA/TIA-232 port on the TCC2/TCC2P card faceplate to create a VT100 emulation window to serve as a TL1 craft interface to the ONS 15454. Use a straight-through cable to connect to the EIA/TIA-232 port. [Table 1-30](#) shows the pin assignments for the CRAFT pin field.

Note

You cannot use the craft backplane pins and the EIA/TIA-232 port on the TCC2/TCC2P card simultaneously.

Note

To use the serial port craft interface wire-wrap pins on the backplane, the DTR signal line on the backplane port wire-wrap pin must be connected and active.

Table 1-30 Craft Interface Pin Assignments

Pin Field	Contact	Function
Craft	A1	Receive
	A2	Transmit
	A3	Ground
	A4	DTR

1.17 Cards and Slots

ONS 15454 cards have electrical plugs at the back that plug into electrical connectors on the shelf-assembly backplane. When the ejectors are fully closed, the card plugs into the assembly backplane. [Figure 1-44](#) shows card installation.

Figure 1-44 Installing Cards in the ONS 15454

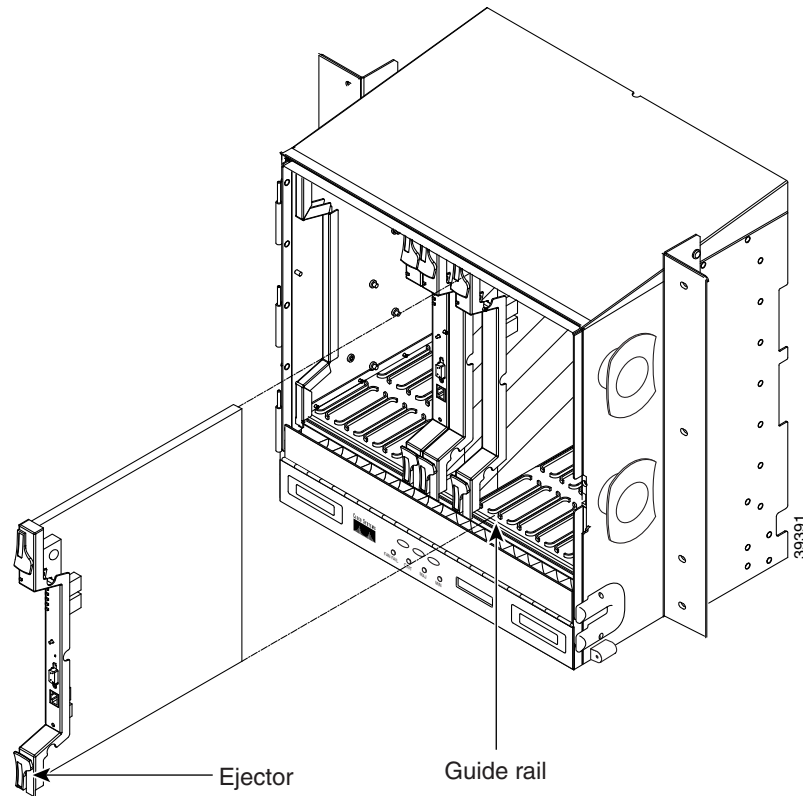

1.17.1 Card Slot Requirements

The ONS 15454 shelf assembly has 17 card slots numbered sequentially from left to right. Slots 1 to 6 and 12 to 17 are multiservice slots that are used for electrical, optical, and Ethernet cards (traffic cards). Card compatibility depends on the EIA, protection scheme, and cross-connect card type used in the shelf. Refer to the “[3.1.2 Card Compatibility](#)” section on page 3-3 for more detailed compatibility information.

Slots 7 and 11 are dedicated to TCC2/TCC2P cards. Slots 8 and 10 are dedicated to cross-connect (XCVT, XC10G, and XC-VXC-10G) cards. Slot 9 is reserved for the optional AIC-I card. Slots 3 and 15 can also host electrical cards that are used for 1:N protection. (See the “[7.1 Electrical Card Protection](#)” section on page 7-1 for a list of electrical cards that can operate as protect cards.)



Caution

Do not operate the ONS 15454 with a single TCC2/TCC2P card or a single XCVT/XC10G/XC-VXC-10G card installed. Always operate the shelf assembly with one working and one protect card of the same type.

Shelf assembly slots have symbols indicating the type of cards that you can install in them. Each ONS 15454 card has a corresponding symbol. The symbol on the card must match the symbol on the slot.

[Table 1-31](#) shows the slot and card symbol definitions.

**Note**

Protection schemes and EIA types can affect slot compatibility.

Table 1-31 Slot and Card Symbols

Symbol Color/Shape	Definition
Orange/Circle	Slots 1 to 6 and 12 to 17. Only install ONS 15454 cards with a circle symbol on the faceplate.
Blue/Triangle	Slots 5, 6, 12, and 13. Only install ONS 15454 cards with circle or a triangle symbol on the faceplate.
Purple/Square	TCC2/TCC2P slot, Slots 7 and 11. Only install ONS 15454 cards with a square symbol on the faceplate.
Green/Cross	Cross-connect (XCVT/XC10G) slot, Slots 8 and 10. Only install ONS 15454 cards with a cross symbol on the faceplate.
Red/P	Protection slot in 1:N protection schemes.
Red/Diamond	AIC-I slot (Slot 9). Only install ONS 15454 cards with a diamond symbol on the faceplate.
Gold/Star	Slots 1 to 4 and 14 to 17. Only install ONS 15454 cards with a star symbol on the faceplate.
Blue/Hexagon	(Only used with the 15454-SA-HD shelf assembly) Slots 3 and 15. Only install ONS 15454 cards with a blue hexagon symbol on the faceplate.

Table 1-32 lists the number of ports, line rates, connector options, and connector locations for ONS 15454 optical and electrical cards.

Table 1-32 Card Ports, Line Rates, and Connectors

Card	Ports	Line Rate per Port	Connector Types	Connector Location
DS1-14	14	1.544 Mbps	SMB w/wire wrap adapter, AMP Champ connector	Backplane
DS1N-14	14	1.544 Mbps	SMB w/wire wrap ¹ adapter, AMP Champ connector	—
DS1/E1-56	56	1.544 Mbps	SMB w/wire wrap ² adapter, AMP Champ connector	—
DS3-12	12	44.736 Mbps	SMB or BNC ¹	Backplane
DS3N-12	12	44.736 Mbps	SMB or BNC ¹	—
DS3-12E	12	44.736 Mbps	SMB or BNC ¹	Backplane
DS3N-12E	12	44.736 Mbps	SMB or BNC ¹	—
DS3XM-6	6	44.736 Mbps	SMB or BNC ¹	Backplane
DS3XM-12	12	89.472 Mbps	SMB or BNC ¹	Backplane

Table 1-32 Card Ports, Line Rates, and Connectors (continued)

Card	Ports	Line Rate per Port	Connector Types	Connector Location
DS3/EC1-48	48	2.147 Gbps	SMB or BNC	Backplane
EC1-12	12	51.84 Mbps	SMB or BNC ¹	Backplane
E100T-12	12	100 Mbps	RJ-45	Faceplate
E1000-2	2	1 Gbps	SC (GBIC)	Faceplate
E100T-G	12	100 Mbps	RJ-45	Faceplate
E1000-2-G	2	1 Gbps	SC (GBIC)	Faceplate
G1K-4	4	1 Gbps	SC (GBIC)	Faceplate
ML100T-12	12	100 Mbps	RJ-45	Faceplate
ML100X-8	8	100 Mbps	SC (SFP)	Faceplate
CE-100T-8	8	100 Mbps	RJ-45	Faceplate
ML1000-2	2	1 Gbps	LC (SFP)	Faceplate
OC-3 IR	4	155.52 Mbps (STS-3)	SC	Faceplate
OC3 IR/STM4 SH 1310-8	8	155.52 Mbps (STS-3)	LC	Faceplate
OC-12/STM4-4 (IR/LR)	4	622.08 Mbps (STS-12)	SC	Faceplate
OC-12 (IR/LR)	1	622.08 Mbps (STS-12)	SC	Faceplate
OC-48 (IR/LR/ELR)	1	2488.32 Mbps (STS-48)	SC	Faceplate
OC-48 AS (IR/LR)	1	2488.32 Mbps (STS-48)	SC	Faceplate
OC-48 ELR (100GHz, 200GHz)	1	2488.32 Mbps (STS-48)	SC	Faceplate
OC192 SR/STM64 IO 1310	1	9.95 Gbps (STS-192)	SC	Faceplate
OC192 IR/STM64 SH 1550	1	9.95 Gbps (STS-192)	SC	Faceplate
OC192 LR/STM64 LH 1550	1	9.95 Gbps (STS-192)	SC	Faceplate
OC192 LR/STM64 LH ITU 15xx.xx	1	9.95 Gbps (STS-192)	SC	Faceplate
FC_MR-4	4 (only 2 available in R4.6)	1.0625 Gbps	SC	Faceplate

Table 1-32 Card Ports, Line Rates, and Connectors (continued)

Card	Ports	Line Rate per Port	Connector Types	Connector Location
15454_MRC-12	12	Up to 2488.32 Mbps (STM-16), depending on SFP	LC	Faceplate
OC192SR1/STM64 IO Short Reach/ OC192/STM64 Any Reach ³	1	9.95 Gbps (STM-64)	LC	Faceplate

1. When used as a protect card, the card does not have a physical external connection. The protect card connects to the working card(s) through the backplane and becomes active when the working card fails. The protect card then uses the physical connection of the failed card.
2. When used as a protect card, the card does not have a physical external connection. The protect card connects to the working card(s) through the backplane and becomes active when the working card fails. The protect card then uses the physical connection of the failed card.
3. These cards are designated as OC192-XFP in CTC.

1.17.2 Card Replacement

To replace an ONS 15454 card with another card of the same type, you do not need to make any changes to the database; remove the old card and replace it with a new card. To replace a card with a card of a different type, physically remove the card and replace it with the new card, then delete the original card from CTC. For specifics, refer to the “Install Cards and Fiber-Optic Cable” chapter in the *Cisco ONS 15454 Procedure Guide*.



Caution

Removing any active card from the ONS 15454 can result in traffic interruption. Use caution when replacing cards and verify that only inactive or standby cards are being replaced. If the active card needs to be replaced, switch it to standby prior to removing the card from the node. For traffic switching procedures, refer to the “Maintain the Node” chapter in the *Cisco ONS 15454 Procedure Guide*.



Note

An improper removal (IMPROPRMVL) alarm is raised whenever a card is removed and reinserted (reseated) is performed, unless the card is deleted in CTC first. The alarm clears after the card replacement is complete.



Note

In a path protection, pulling the active XCVT/XC10G without a lockout causes path protection circuits to switch.

1.17.3 Ferrites

Place third-party ferrites on certain cables to dampen electromagnetic interference (EMI) from the ONS 15454. Ferrites must be added to meet the requirements of Telcordia GR-1089-CORE. Refer to the ferrite manufacturer documentation for proper use and installation of the ferrites. Ferrite placements on the ONS 15454 can include power cables, AMP Champ connectors, baluns, BNC/SMB connectors, and the wire-wrap pin field.

1.18 Software and Hardware Compatibility

Table 1-33 shows ONS 15454 software and hardware compatibility for nodes configured with XC or XCVT cards for Releases 4.6, 4.7, 5.0, 6.0, and 7.0.

For software compatibility for a specific card, refer to the following URL:

http://cisco.com/en/US/products/hw/optical/ps2006/prod_eol_notices_list.html



Note

Partially supported : Once a card has been through End Of Life(EOL), new features would not be supported for the card. However bug fixes would be available.



Note

TCC and TCC+ are only supported up to Release 4.x.

Table 1-33 ONS 15454 Software and Hardware Compatibility—XC¹ and XCVT Configurations

Hardware	Shelf Assembly ²	4.6.0x (4.6)	5.0.0x (5.0)	6.0.0x (6.0)	7.0.0x (7.0)
TCC2	All	Fully compatible	Fully compatible	Fully compatible	Fully compatible
TCC2P	All	Fully compatible	Fully compatible	Fully compatible	Fully compatible
AIC	All	Fully compatible	Fully compatible	Fully compatible	Fully compatible
AIC-I	All	Fully compatible	Fully compatible	Fully compatible	Fully compatible
DS1-14	All	Fully compatible	Fully compatible	Fully compatible	Fully compatible
DS1N-14	All	Fully compatible	Fully compatible	Fully compatible	Fully compatible
DS1/E1-56	SA-HD	Not supported	Not supported	Fully compatible	Fully compatible
DS3-12 ³	All	Fully compatible	Fully compatible	Partially supported	Partially supported
DS3N-12	All	Fully compatible	Fully compatible	Partially supported	Partially supported
DS3i-N-12	All	Fully compatible	Fully compatible	Fully compatible	Fully compatible
DS3-12E	All	Fully compatible	Fully compatible	Fully compatible	Fully compatible
DS3N-12E	All	Fully compatible	Fully compatible	Fully compatible	Fully compatible
DS3XM-6	All	Fully compatible	Fully compatible	Fully compatible	Fully compatible
DS3XM-12	SA-HD and SA-ANSI	Not supported	Fully compatible	Fully compatible	Fully compatible
EC1-12	All	Fully compatible	Fully compatible	Fully compatible	Fully compatible
E100T-12	All	Fully compatible	Fully compatible	Fully compatible	Fully compatible
E1000-2	All	Fully compatible	Fully compatible	Fully compatible	Fully compatible
E100T-12-G	All	Fully compatible	Fully compatible	Fully compatible	Fully compatible
E1000-2-G	All	Fully compatible	Fully compatible	Fully compatible	Fully compatible
G1000-4	All	Fully compatible	Fully compatible	Partially supported	Partially supported
G1K-4	All	Fully compatible	Fully compatible	Fully compatible	Fully compatible
ML100T-12	All	Fully compatible	Fully compatible	Fully compatible	Fully compatible

Table 1-33 ONS 15454 Software and Hardware Compatibility—XC¹ and XCVT Configurations (continued)

Hardware	Shelf Assembly ²	4.6.0x (4.6)	5.0.0x (5.0)	6.0.0x (6.0)	7.0.0x (7.0)
ML1000-2	All	Fully compatible	Fully compatible	Fully compatible	Fully compatible
ML100X-8	All	Not supported	Not supported	Fully compatible	Fully compatible
ML-MR-10 ⁴	SA-HD and SA-ANSI	Not supported	Not supported	Not supported	Not supported
CE-MR-10	SA-HD and SA-ANSI	Not supported	Not supported	Not supported	Not supported
CE-100T-8	All	Not Supported	Fully Compatible	Fully Compatible	Fully Compatible
CE-1000-4	SA-HD and SA-ANSI	Not Supported	Not Supported	Not Supported	Fully Compatible
OC3 IR 4/STM1 SH 1310	All	Fully compatible	Fully compatible	Fully compatible	Fully compatible
OC3IR/STM1S H 1310-8	All	Not supported	Not supported	Not supported	Not supported
OC12 IR 1310	All	Fully compatible	Fully compatible	Fully compatible	Fully compatible
OC12 IR/4 1310	All	Not supported	Not supported	Not supported	Not supported
OC12 LR 1310	All	Fully compatible	Fully compatible	Fully compatible	Fully compatible
OC12 LR 1550	All	Fully compatible	Fully compatible	Fully compatible	Fully compatible
OC48 IR 1310	All	Fully compatible	Fully compatible	Fully compatible	Partially supported
OC48 LR 1550	All	Fully compatible	Fully compatible	Fully compatible	Partially supported
OC48 ELR DWDM	All	Fully compatible	Fully compatible	Fully compatible	Fully compatible
OC48 IR/STM16 SH AS 1310	All	Fully compatible	Fully compatible	Fully compatible	Fully compatible
OC48 LR/STM16 LH AS 1550	All	Fully compatible	Fully compatible	Fully compatible	Fully compatible
OC192 SR/STM64 IO 1310	SA-HD and SA-ANSI	Not supported	Not supported	Not supported	Not supported
OC192 IR/STM64 SH 1550	SA-HD and SA-ANSI	Not supported	Not supported	Not supported	Not supported
OC192 LH/STM64 LH 1550	SA-HD and SA-ANSI	Not supported	Not supported	Not supported	Not supported
OC192 LR/STM64 LH ITU 15xx.xx	SA-HD and SA-ANSI	Not supported	Not supported	Not supported	Not supported

Table 1-33 ONS 15454 Software and Hardware Compatibility—XC¹ and XCVT Configurations (continued)

Hardware	Shelf Assembly ²	4.6.0x (4.6)	5.0.0x (5.0)	6.0.0x (6.0)	7.0.0x (7.0)
FC_MR-4	SA-HD and SA-ANSI	Fully compatible	Fully compatible	Fully compatible	Fully compatible
MRC-12 ⁵	All	Not supported	Not supported	Fully compatible	Fully compatible
MRC-2.5G-4 ⁴	All	Not supported	Not supported	Not supported	Not supported
OC192SR1/ST M64IO Short Reach/ OC192/STM64 Any Reach ⁶	SA-HD and SA-ANSI	Not supported	Not supported	Not supported	Not supported

1. The XC card does not support features new to Release 5.0 and greater.
2. The shelf assemblies supported are 15454-SA-HD, 15454-SA-ANSI, and 15454-NEBS3E.
3. DS3 card having the part number 87-31-0001 does not work in Cisco ONS 15454 R8.0 and later.
4. ML-MR-10 and CE-MR-10 cards are not supported on XCVT.
5. Slots 1 to 4 and 14 to 17 give a total bandwidth of up to 622 Mb/s. Slots 5, 6, 12, and 13 give a total bandwidth of up to 2.5 Gb/s.
6. These cards are designated as OC192-XFP in CTC.

Table 1-34 shows ONS 15454 software and hardware compatibility for systems configured with XC10G or XC-VXC-10G cards for Releases 4.5, 4.6, 4.7, 5.0, 6.0, and 7.0. The 15454-SA-ANSI or 15454-SA-HD shelf assembly is required to operate the XC10G or XC-VXC-10G card. XC-VXC-10G is only supported from Release 6.0. Refer to the older ONS 15454 documentation for compatibility with older software releases.



Note Release 4.7 is for MSTP only. The cards supported in Release 4.7 are TCC2, TCC2P, and AIC, AIC-I.



Note Partially supported : Once a card has been through End Of Life(EOL), new features would not be supported for the card. However bug fixes would be available.

Table 1-34 ONS 15454 Software and Hardware Compatibility—XC10G and XC-VXC-10G Configurations

Hardware	Shelf Assembly ¹	4.6.0x (4.6)	5.0.0x (5.0)	6.0.0x (6.0)	7.0.0x (7.0)
TCC2	All	Fully compatible	Fully compatible	Fully compatible	Fully compatible
TCC2P	All	Fully compatible	Fully compatible	Fully compatible	Fully compatible
XC10G	SA-HD and SA-ANSI	Fully compatible	Fully compatible	Fully compatible	Fully compatible
AIC	All	Fully compatible	Fully compatible	Fully compatible	Fully compatible
AIC-I	All	Fully compatible	Fully compatible	Fully compatible	Fully compatible
DS1-14	All	Fully compatible	Fully compatible	Fully compatible	Fully compatible
DS1N-14	All	Fully compatible	Fully compatible	Fully compatible	Fully compatible
DS1/E1-56	SA-HD	Not supported	Not supported	Fully compatible	Fully compatible

Table 1-34 ONS 15454 Software and Hardware Compatibility—XC10G and XC-VXC-10G Configurations (continued)

Hardware	Shelf Assembly ¹	4.6.0x (4.6)	5.0.0x (5.0)	6.0.0x (6.0)	7.0.0x (7.0)
DS3-12 ²	All	Fully compatible	Fully compatible	Partially supported	Partially supported
DS3N-12	All	Fully compatible	Fully compatible	Partially supported	Partially supported
DS3i-N-12	All	Fully compatible	Fully compatible	Fully compatible	Fully compatible
DS3-12E	All	Fully compatible	Fully compatible	Fully compatible	Fully compatible
DS3N-12E	All	Fully compatible	Fully compatible	Fully compatible	Fully compatible
DS3/EC1-48 ¹	SA-HD	Not supported	Fully compatible	Fully compatible	Fully compatible
DS3XM-6	All	Fully compatible	Fully compatible	Fully compatible	Fully compatible
DS3XM-12	SA-HD and SA-ANSI	Not supported	Fully compatible	Fully compatible	Fully compatible
EC1-12	All	Fully compatible	Fully compatible	Fully compatible	Fully compatible
SVC-RAN	SA-HD and SA-ANSI	Not supported	Not supported	Not supported	Not supported
E100T	SA-HD and SA-ANSI	Not supported	Not supported	Not supported	Not supported
E1000	SA-HD and SA-ANSI	Not supported	Not supported	Not supported	Not supported
E100T-12-G	All	Fully compatible	Fully compatible	Fully compatible	Fully compatible
E1000-2-G	All	Fully compatible	Fully compatible	Fully compatible	Fully compatible
G1000-4	All	Fully compatible	Fully compatible	Partially supported	Partially supported
G1K-4	SA-HD and SA-ANSI	Fully compatible	Fully compatible	Fully compatible	Fully compatible
ML100T-12	All	Fully compatible	Fully compatible	Fully compatible	Fully compatible
ML1000-2	All	Fully compatible	Fully compatible	Fully compatible	Fully compatible
ML100X-8	All	Not supported	Not supported	Fully compatible	Fully compatible
ML-MR-10	SA-HD and SA-ANSI	Not supported	Not supported	Not supported	Not supported
CE-MR-10	SA-HD and SA-ANSI	Not supported	Not supported	Not supported	Not supported
CE-100T-8	All	Not supported	Fully compatible	Fully compatible	Fully compatible
CE-1000-4	SA-HD and SA-ANSI	Not supported	Not supported	Not supported	Fully compatible
OC3 IR 4/STM1 SH 1310	All	Fully compatible	Fully compatible	Fully compatible	Fully compatible
OC3IR/STM1SH 1310-8	SA-HD and SA-ANSI	Fully compatible	Fully compatible	Fully compatible	Fully compatible
OC12/STM4-4	SA-HD and SA-ANSI	Fully compatible	Fully compatible	Fully compatible	Fully compatible
OC12 IR 1310	All	Fully compatible	Fully compatible	Fully compatible	Fully compatible

Table 1-34 ONS 15454 Software and Hardware Compatibility—XC10G and XC-VXC-10G Configurations (continued)

Hardware	Shelf Assembly ¹	4.6.0x (4.6)	5.0.0x (5.0)	6.0.0x (6.0)	7.0.0x (7.0)
OC12 LR 1310	All	Fully compatible	Fully compatible	Fully compatible	Fully compatible
OC12 LR 1550	All	Fully compatible	Fully compatible	Fully compatible	Fully compatible
OC48 IR 1310	All	Fully compatible	Fully compatible	Fully compatible	Partially supported
OC48 LR 1550	All	Fully compatible	Fully compatible	Fully compatible	Partially supported
OC48 IR/STM16 SH AS 1310	SA-HD and SA-ANSI	Fully compatible	Fully compatible	Fully compatible	Fully compatible
OC48 LR/STM16 LH AS 1550	SA-HD and SA-ANSI	Fully compatible	Fully compatible	Fully compatible	Fully compatible
OC192 SR/STM64 IO 1310	SA-HD and SA-ANSI	Fully compatible	Fully compatible	Fully compatible	Fully compatible
OC192 IR/STM64 SH 1550	SA-HD and SA-ANSI	Fully compatible	Fully compatible	Fully compatible	Fully compatible
OC192 LH/STM64 LH 1550	SA-HD and SA-ANSI	Fully compatible	Fully compatible	Fully compatible	Fully compatible
OC192 LR/STM64 LH ITU 15xx.xx	SA-HD and SA-ANSI	Fully compatible	Fully compatible	Fully compatible	Fully compatible
FC_MR-4	SA-HD and SA-ANSI	Fully compatible	Fully compatible	Fully compatible	Fully compatible
MRC-12 ³	All	Not supported	Not supported	Fully compatible	Fully compatible
MRC-2.5G-4	All	Not supported	Not supported	Not supported	Not supported
OC192SR1/STM64IO Short Reach/OC192/STM64 Any Reach ⁴	SA-HD and SA-ANSI	Not supported	Not supported	Fully compatible	Fully compatible

1. The shelf assemblies supported are 15454-SA-HD and 15454-SA-ANSI.
2. DS3 card having the part number 87-31-0001 does not work in Cisco ONS 15454 R8.0 and later.
3. Slots 1 to 4 and 14 to 17 give a total bandwidth of up to 2.5 Gb/s. Slots 5, 6, 12, and 13 give a total bandwidth of up to 10 Gb/s.
4. These cards are designated as OC192-XFP in CTC.

If an upgrade is required for compatibility, contact the Cisco Technical Assistance Center (TAC). For contact information, go to <http://www.cisco.com/tac>.



CHAPTER 2

Common Control Cards



Note

The terms "Unidirectional Path Switched Ring" and "UPSR" may appear in Cisco literature. These terms do not refer to using Cisco ONS 15xxx products in a unidirectional path switched ring configuration. Rather, these terms, as well as "Path Protected Mesh Network" and "PPMN," refer generally to Cisco's path protection feature, which may be used in any topological network configuration. Cisco does not recommend using its path protection feature in any particular topological network configuration.

This chapter describes Cisco ONS 15454 common control card functions. For installation and turn-up procedures, refer to the *Cisco ONS 15454 Procedure Guide*.

Chapter topics include:

- [2.1 Common Control Card Overview, page 2-1](#)
- [2.2 TCC2 Card, page 2-6](#)
- [2.3 TCC2P Card, page 2-10](#)
- [2.4 XCVT Card, page 2-14](#)
- [2.5 XC10G Card, page 2-18](#)
- [2.6 XC-VXC-10G Card, page 2-22](#)
- [2.7 AIC-I Card, page 2-27](#)

2.1 Common Control Card Overview

The card overview section summarizes card functions and compatibility.

Each card is marked with a symbol that corresponds to a slot (or slots) on the ONS 15454 shelf assembly. The cards are then installed into slots displaying the same symbols. See the "[1.17.1 Card Slot Requirements](#)" section on [page 1-69](#) for a list of slots and symbols.

2.1.1 Cards Summary

[Table 2-1](#) lists the common control cards for the Cisco ONS 15454 and summarizes card functions.

Table 2-1 Common Control Card Functions

Card	Description	For Additional Information...
TCC2	The Advanced Timing, Communications, and Control (TCC2) card is the main processing center for the ONS 15454 and provides system initialization, provisioning, alarm reporting, maintenance, and diagnostics. It has additional features including supply voltage monitoring, support for up to 84 data communications channel/generic communications channel (DCC/GCC) terminations, and an on-card lamp test.	See the “2.2 TCC2 Card” section on page 2-6.
TCC2P	The Advanced Timing, Communications, and Control Plus (TCC2P) card is the main processing center for the ONS 15454 and provides system initialization, provisioning, alarm reporting, maintenance, and diagnostics. It also provides supply voltage monitoring, support for up to 84 DCC/GCC terminations, and an on-card lamp test. This card also has Ethernet security features and 64K composite clock building integrated timing supply (BITS) timing.	See the “2.3 TCC2P Card” section on page 2-10.
XCVT	The Cross Connect Virtual Tributary (XCVT) card is the central element for switching; it establishes connections and performs time-division switching (TDS). The XCVT can manage STS and Virtual Tributary (VT) circuits up to 48c.	See the “2.4 XCVT Card” section on page 2-14.
XC10G	The 10 Gigabit Cross Connect (XC10G) card is the central element for switching; it establishes connections and performs TDS. The XC10G can manage STS and VT circuits up to 192c. The XC10G allows up to four times the bandwidth of XC and XCVT cards.	See the “2.5 XC10G Card” section on page 2-18.
XC-VXC-10G	The 10 Gigabit Cross Connect Virtual Tributary/Virtual Container (XC-VXC-10G) card serves as the switching matrix for the Cisco 15454 ANSI multiservice platform. The module operates as a superset of the XCVT or XC10G cross-connect module. The XC-VXC-10G card provides a maximum of 1152 STS-1 or 384 VC4 cross-connections and supports cards with speeds up to 10 Gbps.	See the “2.6 XC-VXC-10G Card” section on page 2-22.
AIC-I	The Alarm Interface Card–International (AIC-I) provides customer-defined (environmental) alarms with its additional input/output alarm contact closures. It also provides orderwire, user data channels, and supply voltage monitoring.	See the “2.7 AIC-I Card” section on page 2-27.
AEP	The alarm expansion panel (AEP) board provides 48 dry alarm contacts: 32 inputs and 16 outputs. It can be used with the AIC-I card.	See the “1.12 Alarm Expansion Panel” section on page 1-55

2.1.2 Card Compatibility

Table 2-2 lists the Cisco Transport Controller (CTC) software release compatibility for each common-control card. In the tables below, “Yes” means cards are compatible with the listed software versions. Table cells with dashes mean cards are not compatible with the listed software versions.

Table 2-2 Common-Control Card Software Release Compatibility

Card	R2.2.1	R2.2.2	R3.0.1	R3.1	R3.2	R3.3	R3.4	R4.0	R4.1	R4.5	R4.6	R4.7	R5.0	R6.0	R7.0
TCC+	Yes	Yes	Yes	Yes	Yes	Yes	Yes	Yes	Yes	—	—	—	—	—	—
TCC2	—	—	—	—	—	—	—	Yes	Yes	Yes	Yes	Yes	Yes	Yes	Yes
TCC2P	—	—	—	—	—	—	—	Yes	Yes	Yes	Yes	Yes	Yes	Yes	Yes
XC	Yes	Yes	Yes	Yes	Yes	Yes	Yes	Yes	Yes	—	Yes	—	Yes ¹	Yes ¹	Yes ¹
XCVT	Yes	Yes	Yes	Yes	Yes	Yes	Yes	Yes	Yes	—	Yes	—	Yes	Yes	Yes
XC10G	—	—	—	Yes	Yes	Yes	Yes	Yes	Yes	—	Yes	—	Yes	Yes	Yes
XC-VXC-10G	—	—	—	—	—	—	—	—	—	—	—	—	—	Yes	Yes
AIC	Yes	Yes	Yes	Yes	Yes	Yes	Yes	Yes	Yes	Yes	Yes	Yes	Yes	Yes	Yes
AIC-I	—	—	—	—	—	—	Yes	Yes	Yes	Yes	Yes	Yes	Yes	Yes	Yes
AEP	—	—	—	—	—	—	Yes	Yes	Yes	Yes	Yes	Yes	Yes	Yes	Yes

1. The XC card does not support features new to Release 5.0 and greater.

2.1.3 Cross-Connect Card Compatibility

The following tables list the compatible cross-connect cards for each Cisco ONS 15454 common-control card. The tables are organized according to type of common-control card. In the tables below, “Yes” means cards are compatible with the listed cross-connect card. Table cells with dashes mean cards are not compatible with the listed cross-connect card.

Table 2-3 lists the cross-connect card compatibility for each common-control card.

Table 2-3 Common-Control Card Cross-Connect Compatibility

Card	XCVT Card	XC10G Card ¹	XC-VXC-10G Card ¹
TCC+ ²	Yes	Yes	—
TCC2	Yes	Yes	Yes
TCC2P	Yes	Yes	Yes
XC	— ³	— ³	— ³
XCVT	Yes	— ³	— ³
XC10G	— ³	Yes	— ³
XC-VXC-10G	— ³	— ³	Yes
AIC-I	Yes	Yes	Yes
AEP	Yes	Yes	Yes

1. Requires SA-ANSI or SA-HD shelf assembly.

2. The TCC+ is not compatible with Software R4.5 or greater.
3. These cross-connect cards are compatible only during an upgrade.

Table 2-4 lists the cross-connect card compatibility for each electrical card. For electrical card software compatibility, see Table 3-2 on page 3-3.

**Note**

The XC card is compatible with most electrical cards, with the exception of the DS3i-N-12, DS3/EC1-48, DS1/E1-56, and transmux cards, but does not support features new to Release 5.0 and greater.

Table 2-4 Electrical Card Cross-Connect Compatibility

Electrical Card	XCVT Card	XC10G Card ¹	XC-VXC-10G Card ¹
EC1-12	Yes	Yes	Yes
DS1-14	Yes	Yes	Yes
DS1N-14	Yes	Yes	Yes
DS3-12	Yes	Yes	Yes
DS3N-12	Yes	Yes	Yes
DS3-12E	Yes	Yes	Yes
DS3N-12E	Yes	Yes	Yes
DS3/EC1-48	—	Yes	Yes
DS3XM-6 (Transmux)	Yes	Yes	Yes
DS3XM-12 (Transmux)	Yes	Yes	Yes
DS3i-N-12	Yes	Yes	Yes
DS1/E1-56	Yes	Yes	Yes

1. Requires a 15454-SA-ANSI or 15454-SA-HD shelf assembly.

Table 2-5 lists the cross-connect card compatibility for each optical card. For optical card software compatibility, see Table 4-2 on page 4-4.

**Note**

The XC card is compatible with most optical cards, with the exception of those cards noted as incompatible with the XCVT card, but does not support features new to Release 5.0 and greater.

Table 2-5 Optical Card Cross-Connect Compatibility

Optical Card	XCVT Card	XC10G Card ¹	XC-VXC-10G Card ¹
OC3 IR 4 1310	Yes	Yes	Yes
OC3 IR 4/STM1 SH 1310	Yes	Yes	Yes
OC3 IR /STM1SH 1310-8	—	Yes	Yes
OC12 IR 1310	Yes	Yes	Yes
OC12 LR 1310	Yes	Yes	Yes

Table 2-5 *Optical Card Cross-Connect Compatibility (continued)*

Optical Card	XCVT Card	XC10G Card ¹	XC-VXC-10GCard ¹
OC12 LR 1550	Yes	Yes	Yes
OC12 IR/STM4 SH 1310	Yes	Yes	Yes
OC12 LR/STM4 LH 1310	Yes	Yes	Yes
OC12 LR/STM4 LH 1550	Yes	Yes	Yes
OC12 IR/STM4 SH 1310-4	—	Yes	Yes
OC48 IR 1310	Yes	Yes	Yes
OC48 LR 1550	Yes	Yes	Yes
OC48 IR/STM16 SH AS 1310	Yes ²	Yes	Yes
OC48 LR/STM16 LH AS 1550	Yes ²	Yes	Yes
OC48 ELR/STM16 EH 100 GHz	Yes	Yes	Yes
OC48 ELR 200 GHz	Yes	Yes	Yes
OC192 SR/STM64 IO 1310	—	Yes	Yes
OC192 IR/STM64 SH 1550	—	Yes	Yes
OC192 LR/STM64 LH 1550	—	Yes	Yes
OC192 LR/STM64 LH ITU 15xx.xx	—	Yes	Yes
OC192SR1/STM64 IO Short Reach and OC192/STM64 Any Reach (OC192-XFP cards)	—	Yes	Yes
15454_MRC-12	Yes	Yes	Yes

1. Requires a 15454-SA-ANSI or 15454-SA-HD shelf assembly.

2. Requires Software Release 3.2 and later in Slots 5, 6, 12, 13.

Table 2-6 lists the cross-connect card compatibility for each Ethernet card. For Ethernet card software compatibility, see Table 5-2 on page 5-3.

**Note**

The XC card is compatible with most Ethernet cards, with the exception of the G1000-4, but does not support features new to Release 5.0 and greater.

Table 2-6 *Ethernet Card Cross-Connect Compatibility*

Ethernet Cards	XCVT Card	XC10G Card ¹	XC-VXC-10G Card ¹
E100T-12	Yes	—	—
E1000-2	Yes	—	—
E100T-G	Yes	Yes	Yes
E1000-2-G	Yes	Yes	Yes
G1K-4	Yes, in Slots 5, 6, 12, 13	Yes	Yes
ML100T-12	Yes, in Slots 5, 6, 12, 13	Yes	Yes
ML1000-2	Yes, in Slots 5, 6, 12, 13	Yes	Yes

Table 2-6 Ethernet Card Cross-Connect Compatibility (continued)

Ethernet Cards	XCVT Card	XC10G Card ¹	XC-VXC-10G Card ¹
ML100X-8	Yes, in Slots 5, 6, 12, 13	Yes	Yes
CE-100T-8	Yes	Yes	Yes
CE-1000-4	Yes	Yes	Yes

1. Requires a 15454-SA-ANSI or 15454-SA-HD shelf assembly.

Table 2-7 lists the cross-connect card compatibility for each storage area network (SAN) card. For SAN card software compatibility, see the “6.1.3 FC_MR-4 Compatibility” section on page 6-4.

Table 2-7 SAN Card Cross-Connect Compatibility

SAN Cards	XCVT Card	XC10G Card ¹	XC-VXC-10G Card ¹
FC_MR-4	Yes	Yes	Yes

1. Requires SA-ANSI or SA-HD shelf assembly

2.2 TCC2 Card



Note

For hardware specifications, see the “A.4.1 TCC2 Card Specifications” section on page A-10.

The TCC2 card performs system initialization, provisioning, alarm reporting, maintenance, diagnostics, IP address detection/resolution, SONET section overhead (SOH) DCC/GCC termination, and system fault detection for the ONS 15454. The TCC2 also ensures that the system maintains Stratum 3 (Telcordia GR-253-CORE) timing requirements. It monitors the supply voltage of the system.



Note

The TCC2 card requires Software Release 4.0.0 or later.



Note

The LAN interface of the TCC2 card meets the standard Ethernet specifications by supporting a cable length of 328 ft (100 m) at temperatures from 32 to 149 degrees Fahrenheit (0 to 65 degrees Celsius). The interfaces can operate with a cable length of 32.8 ft (10 m) maximum at temperatures from –40 to 32 degrees Fahrenheit (–40 to 0 degrees Celsius).

Figure 2-1 shows the faceplate and block diagram for the TCC2 card.

Figure 2-1 TCC2 Card Faceplate and Block Diagram

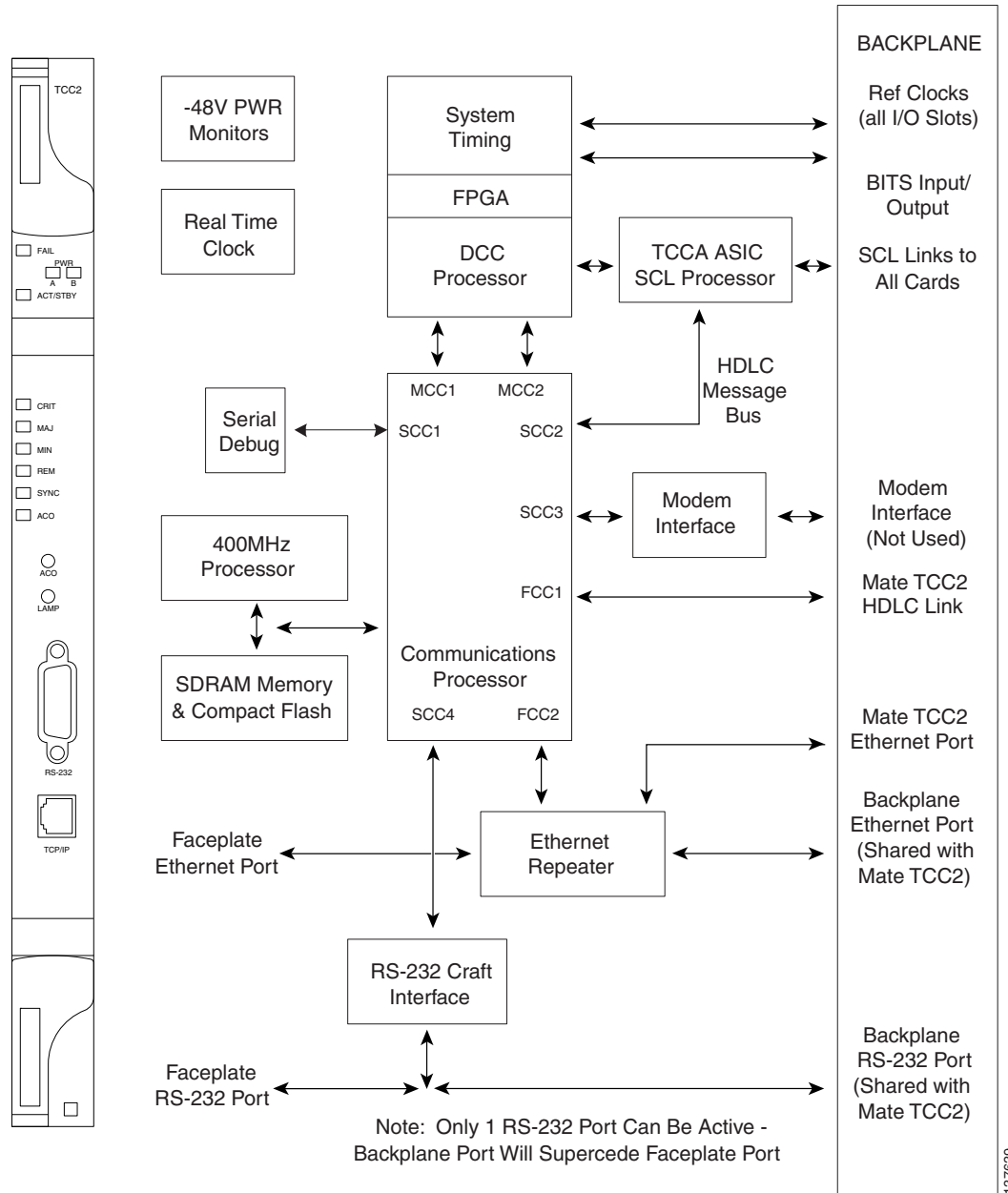

2.2.1 TCC2 Card Functionality

The TCC2 card supports multichannel, high-level data link control (HDLC) processing for the DCC. Up to 84 DCCs can be routed over the TCC2 card and up to 84 section DCCs can be terminated at the TCC2 card (subject to the available optical digital communication channels). The TCC2 card selects and processes 84 DCCs to facilitate remote system management interfaces.

The TCC2 card also originates and terminates a cell bus carried over the module. The cell bus supports links between any two cards in the node, which is essential for peer-to-peer communication. Peer-to-peer communication accelerates protection switching for redundant cards.

The node database, IP address, and system software are stored in TCC2 card nonvolatile memory, which allows quick recovery in the event of a power or card failure.

The TCC2 card performs all system-timing functions for each ONS 15454. The TCC2 monitors the recovered clocks from each traffic card and two BITS ports (DS1, 1.544 MHz) for frequency accuracy. The TCC2 selects a recovered clock, a BITS, or an internal Stratum 3 reference as the system-timing reference. You can provision any of the clock inputs as primary or secondary timing sources. A slow-reference tracking loop allows the TCC2 to synchronize with the recovered clock, which provides holdover if the reference is lost.

The TCC2 monitors both supply voltage inputs on the shelf. An alarm is generated if one of the supply voltage inputs has a voltage out of the specified range.

Install TCC2 cards in Slots 7 and 11 for redundancy. If the active TCC2 fails, traffic switches to the protect TCC2. All TCC2 protection switches conform to protection switching standards when the bit error rate (BER) counts are not in excess of $1 * 10 \text{ exp} - 3$ and completion time is less than 50 ms.

The TCC2 card has two built-in interface ports for accessing the system: an RJ-45 10BaseT LAN interface and an EIA/TIA-232 ASCII interface for local craft access. It also has a 10BaseT LAN port for user interfaces over the backplane.

**Note**

When using the LAN RJ-45 craft interface or back panel wirewrap LAN connection, the connection must be 10BASE T, half duplex. Full duplex and autonegotiate settings should not be used because they might result in a loss of visibility to the node.

**Note**

Cisco does not support operation of the ONS 15454 with only one TCC2 card. For full functionality and to safeguard your system, always operate with two TCC2 cards.

**Note**

When a second TCC2 card is inserted into a node, it synchronizes its software, its backup software, and its database with the active TCC2. If the software version of the new TCC2 does not match the version on the active TCC2, the newly inserted TCC2 copies from the active TCC2, taking about 15 to 20 minutes to complete. If the backup software version on the new TCC2 does not match the version on the active TCC2, the newly inserted TCC2 copies the backup software from the active TCC2 again, taking about 15 to 20 minutes. Copying the database from the active TCC2 takes about 3 minutes. Depending on the software version and backup version the new TCC2 started with, the entire process can take between 3 and 40 minutes.

2.2.2 TCC2 Card-Level Indicators

The TCC2 faceplate has ten LEDs. [Table 2-8](#) describes the two card-level LEDs on the TCC2 card faceplate.

Table 2-8 TCC2 Card-Level Indicators

Card-Level LEDs	Definition
Red FAIL LED	This LED is on during reset. The FAIL LED flashes during the boot and write process. Replace the card if the FAIL LED persists.
ACT/STBY LED Green (Active) Amber (Standby)	Indicates the TCC2 is active (green) or in standby (amber) mode. The ACT/STBY LED also provides the timing reference and shelf control. When the active TCC2 is writing to its database or to the standby TCC2 database, the card LEDs blink. To avoid memory corruption, do not remove the TCC2 when the active or standby LED is blinking.

2.2.3 Network-Level Indicators

Table 2-9 describes the six network-level LEDs on the TCC2 faceplate.

Table 2-9 TCC2 Network-Level Indicators

System-Level LEDs	Definition
Red CRIT LED	Indicates critical alarms in the network at the local terminal.
Red MAJ LED	Indicates major alarms in the network at the local terminal.
Amber MIN LED	Indicates minor alarms in the network at the local terminal.
Red REM LED	Provides first-level alarm isolation. The remote (REM) LED turns red when an alarm is present in one or more of the remote terminals.
Green SYNC LED	Indicates that node timing is synchronized to an external reference.
Green ACO LED	After pressing the alarm cutoff (ACO) button, the ACO LED turns green. The ACO button opens the audible alarm closure on the backplane. ACO is stopped if a new alarm occurs. After the originating alarm is cleared, the ACO LED and audible alarm control are reset.

2.2.4 Power-Level Indicators

Table 2-10 describes the two power-level LEDs on the TCC2 faceplate.

Table 2-10 TCC2 Power-Level Indicators

Power-Level LEDs	Definition
Green/Amber/Red PWR A LED	The PWR A LED is green when the voltage on supply input A is between the low battery voltage (LWBATVG) and high battery voltage (HIBATVG) thresholds. The LED is amber when the voltage on supply input A is between the high battery voltage and extremely high battery voltage (EHIBATVG) thresholds or between the low battery voltage and extremely low battery voltage (ELWBATVG) thresholds. The LED is red when the voltage on supply input A is above extremely high battery voltage or below extremely low battery voltage thresholds.
Green/Amber/Red PWR B LED	The PWR B LED is green when the voltage on supply input B is between the low battery voltage and high battery voltage thresholds. The LED is amber when the voltage on supply input B is between the high battery voltage and extremely high battery voltage thresholds or between the low battery voltage and extremely low battery voltage thresholds. The LED is red when the voltage on supply input B is above extremely high battery voltage or below extremely low battery voltage thresholds.

2.3 TCC2P Card



Note

For hardware specifications, see the [“A.4.2 TCC2P Card Specifications”](#) section on page A-11.

The TCC2P card is an enhanced version of the TCC2 card. For Software Release 5.0 and later, the primary enhancements are Ethernet security features and 64K composite clock BITS timing.

The TCC2P card performs system initialization, provisioning, alarm reporting, maintenance, diagnostics, IP address detection/resolution, SONET SOH DCC/GCC termination, and system fault detection for the ONS 15454. The TCC2P card also ensures that the system maintains Stratum 3 (Telcordia GR-253-CORE) timing requirements. It monitors the supply voltage of the system.



Note

The TCC2P card requires Software Release 4.0.0 or later.



Note

The LAN interface of the TCC2P card meets the standard Ethernet specifications by supporting a cable length of 328 ft (100 m) at temperatures from 32 to 149 degrees Fahrenheit (0 to 65 degrees Celsius). The interfaces can operate with a cable length of 32.8 ft (10 m) maximum at temperatures from –40 to 32 degrees Fahrenheit (–40 to 0 degrees Celsius).

Figure 2-2 shows the faceplate and block diagram for the TCC2P card.

Figure 2-2 TCC2P Faceplate and Block Diagram

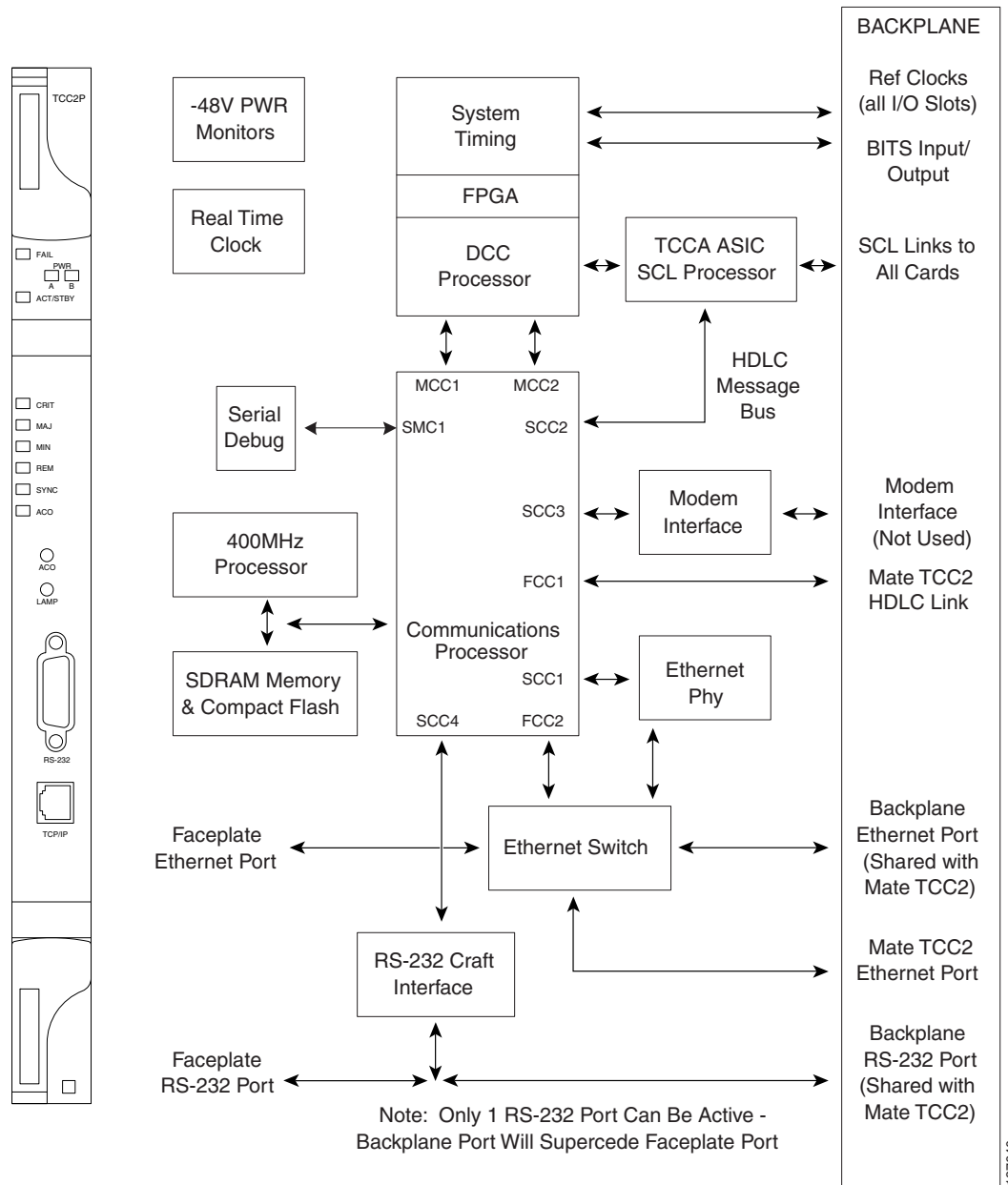

2.3.1 TCC2P Functionality

The TCC2P card supports multichannel, high-level data link control (HDLC) processing for the DCC. Up to 84 DCCs can be routed over the TCC2P card and up to 84 section DCCs can be terminated at the TCC2P card (subject to the available optical digital communication channels). The TCC2P selects and processes 84 DCCs to facilitate remote system management interfaces.

The TCC2P card also originates and terminates a cell bus carried over the module. The cell bus supports links between any two cards in the node, which is essential for peer-to-peer communication. Peer-to-peer communication accelerates protection switching for redundant cards.

The node database, IP address, and system software are stored in TCC2P card nonvolatile memory, which allows quick recovery in the event of a power or card failure.

The TCC2P card performs all system-timing functions for each ONS 15454. The TCC2P card monitors the recovered clocks from each traffic card and two BITS ports for frequency accuracy. The TCC2P card selects a recovered clock, a BITS clock, or an internal Stratum 3 reference as the system-timing reference. You can provision any of the clock inputs as primary or secondary timing sources. A slow-reference tracking loop allows the TCC2P card to synchronize with the recovered clock, which provides holdover if the reference is lost.

The TCC2P card supports a 64 kHz + 8 kHz composite clock BITS input (BITS IN) as well as a 6.312-MHz BITS OUT clock. The BITS clock on the system is configurable as DS1 (default), 1.544 MHz, or 64 kHz. The BITS OUT clock runs at a rate determined by the BITS IN clock, as follows:

If BITS IN = DS1, then BITS OUT = DS1 (default)

A BITS output interface configured as 6.312 MHz complies with ITU-T G.703, Appendix II, Table II.4, with a monitor level of -40 dBm +/- 4 dBm.

The TCC2P card monitors both supply voltage inputs on the shelf. An alarm is generated if one of the supply voltage inputs has a voltage out of the specified range.

Install TCC2P cards in Slots 7 and 11 for redundancy. If the active TCC2P card fails, traffic switches to the protect TCC2P card. All TCC2P card protection switches conform to protection switching standards when the BER counts are not in excess of $1 * 10^{exp - 3}$ and completion time is less than 50 ms.

The TCC2P card has two built-in Ethernet interface ports for accessing the system: one built-in RJ-45 port on the front faceplate for on-site craft access and a second port on the backplane. The rear Ethernet interface is for permanent LAN access and all remote access via TCP/IP as well as for Operations Support System (OSS) access. The front and rear Ethernet interfaces can be provisioned with different IP addresses using CTC.

Two EIA/TIA-232 serial ports, one on the faceplate and a second on the backplane, allow for craft interface in TL1 mode.

**Note**

To use the serial port craft interface wire-wrap pins on the backplane, the DTR signal line on the backplane port wire-wrap pin must be connected and active.

**Note**

When using the LAN RJ-45 craft interface or back panel wirewrap LAN connection, the connection must be 10BASE T, half duplex. Full duplex and autonegotiate settings should not be used because they might result in a loss of visibility to the node.

**Note**

Cisco does not support operation of the ONS 15454 with only one TCC2P card. For full functionality and to safeguard your system, always operate with two TCC2P cards.

**Note**

When a second TCC2P card is inserted into a node, it synchronizes its software, its backup software, and its database with the active TCC2P card. If the software version of the new TCC2P card does not match the version on the active TCC2P card, the newly inserted TCC2P card copies from the active TCC2P

card, taking about 15 to 20 minutes to complete. If the backup software version on the new TCC2P card does not match the version on the active TCC2P card, the newly inserted TCC2P card copies the backup software from the active TCC2P card again, taking about 15 to 20 minutes. Copying the database from the active TCC2P card takes about 3 minutes. Depending on the software version and backup version the new TCC2P card started with, the entire process can take between 3 and 40 minutes.

2.3.2 TCC2P Card-Level Indicators

The TCC2P faceplate has ten LEDs. [Table 2-11](#) describes the two card-level LEDs on the TCC2P faceplate.

Table 2-11 TCC2P Card-Level Indicators

Card-Level LEDs	Definition
Red FAIL LED	This LED is on during reset. The FAIL LED flashes during the boot and write process. Replace the card if the FAIL LED persists.
ACT/STBY LED Green (Active) Amber (Standby)	Indicates the TCC2P is active (green) or in standby (amber) mode. The ACT/STBY LED also provides the timing reference and shelf control. When the active TCC2P is writing to its database or to the standby TCC2P database, the card LEDs blink. To avoid memory corruption, do not remove the TCC2P when the active or standby LED is blinking.

2.3.3 Network-Level Indicators

[Table 2-12](#) describes the six network-level LEDs on the TCC2P faceplate.

Table 2-12 TCC2P Network-Level Indicators

System-Level LEDs	Definition
Red CRIT LED	Indicates critical alarms in the network at the local terminal.
Red MAJ LED	Indicates major alarms in the network at the local terminal.
Amber MIN LED	Indicates minor alarms in the network at the local terminal.
Red REM LED	Provides first-level alarm isolation. The REM LED turns red when an alarm is present in one or more of the remote terminals.
Green SYNC LED	Indicates that node timing is synchronized to an external reference.
Green ACO LED	After pressing the ACO button, the ACO LED turns green. The ACO button opens the audible alarm closure on the backplane. ACO is stopped if a new alarm occurs. After the originating alarm is cleared, the ACO LED and audible alarm control are reset.

2.3.4 Power-Level Indicators

Table 2-13 describes the two power-level LEDs on the TCC2P faceplate.

Table 2-13 TCC2P Power-Level Indicators

Power-Level LEDs	Definition
Green/Amber/Red PWR A LED	The PWR A LED is green when the voltage on supply input A is between the low battery voltage (LWBATVG) and high battery voltage (HIBATVG) thresholds. The LED is amber when the voltage on supply input A is between the high battery voltage and extremely high battery voltage (EHIBATVG) thresholds or between the low battery voltage and extremely low battery voltage (ELWBATVG) thresholds. The LED is red when the voltage on supply input A is above extremely high battery voltage or below extremely low battery voltage thresholds.
Green/Amber/Red PWR B LED	The PWR B LED is green when the voltage on supply input B is between the low battery voltage and high battery voltage thresholds. The LED is amber when the voltage on supply input B is between the high battery voltage and extremely high battery voltage thresholds or between the low battery voltage and extremely low battery voltage thresholds. The LED is red when the voltage on supply input B is above extremely high battery voltage or below extremely low battery voltage thresholds.

2.4 XCVT Card



Note

For hardware specifications, see the [“A.4.3 XCVT Card Specifications”](#) section on page A-12.

The Cross Connect Virtual Tributary (XCVT) card establishes connections at the STS-1 and VT levels. The XCVT provides STS-48 capacity to Slots 5, 6, 12, and 13, and STS-12 capacity to Slots 1 to 4 and 14 to 17. Any STS-1 on any port can be connected to any other port, meaning that the STS cross-connections are nonblocking.

Figure 2-3 shows the XCVT faceplate and block diagram.

Figure 2-3 XCVT Faceplate and Block Diagram

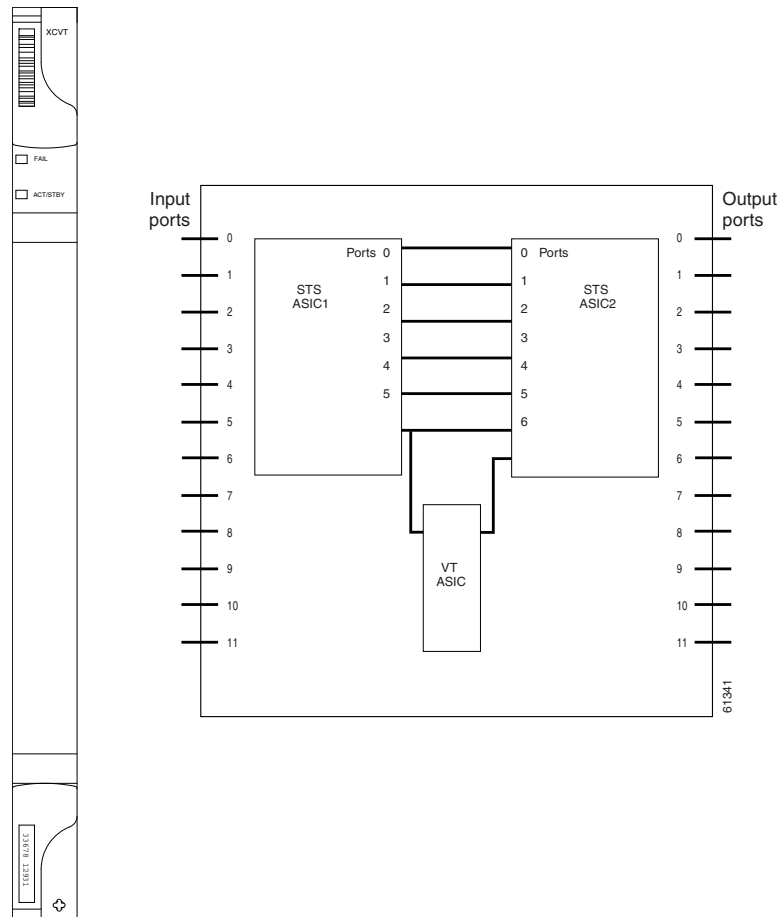

2.4.1 XCVT Functionality

The STS-1 switch matrix on the XCVT card consists of 288 bidirectional ports and adds a VT matrix that can manage up to 336 bidirectional VT1.5 ports or the equivalent of a bidirectional STS-12. The VT1.5-level signals can be cross connected, dropped, or rearranged. The TCC2/TCC2P card assigns bandwidth to each slot on a per STS-1 or per VT1.5 basis. The switch matrices are fully crosspoint and broadcast supporting.

The XCVT card provides:

- 288 STS bidirectional ports
- 144 STS bidirectional cross-connects
- 672 VT1.5 ports via 24 logical STS ports
- 336 VT1.5 bidirectional cross-connects
- Nonblocking at the STS level
- STS-1/3c/6c/12c/48c cross-connects

The XCVT card works with the TCC2/TCC2P cards to maintain connections and set up cross-connects within the node. The cross-connect cards (such as the XCVT and XC10G), installed in Slots 8 and 10, are required to operate the ONS 15454. You can establish cross-connect (circuit) information through CTC. The TCC2/TCC2P cards establish the proper internal cross-connect information and relay the setup information to the XCVT card.

**Caution**

Do not operate the ONS 15454 with only one cross-connect card. Two cross-connect cards of the same type (two XCVT or two XC10G cards) must always be installed.

Figure 2-4 shows the cross-connect matrix.

Figure 2-4 XCVT Cross-Connect Matrix

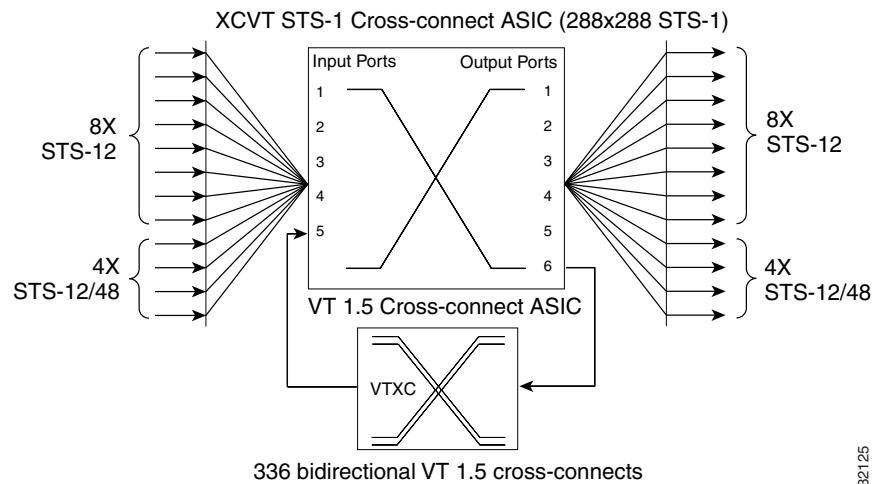

2.4.2 VT Mapping

The VT structure is designed to transport and switch payloads below the DS-3 rate. The ONS 15454 performs VT mapping according to Telcordia GR-253-CORE standards. Table 2-14 shows the VT numbering scheme for the ONS 15454 as it relates to the Telcordia standard.

Table 2-14 VT Mapping

ONS 15454 VT Number	Telcordia Group/VT Number
VT1	Group1/VT1
VT2	Group2/VT1
VT3	Group3/VT1
VT4	Group4/VT1
VT5	Group5/VT1
VT6	Group6/VT1
VT7	Group7/VT1
VT8	Group1/VT2

Table 2-14 VT Mapping (continued)

ONS 15454 VT Number	Telcordia Group/VT Number
VT9	Group2/VT2
VT10	Group3/VT2
VT11	Group4/VT2
VT12	Group5/VT2
VT13	Group6/VT2
VT14	Group7/VT2
VT15	Group1/VT3
VT16	Group2/VT3
VT17	Group3/VT3
VT18	Group4/VT3
VT19	Group5/VT3
VT20	Group6/VT3
VT21	Group7/VT3
VT22	Group1/VT4
VT23	Group2/VT4
VT24	Group3/VT4
VT25	Group4/VT4
VT26	Group5/VT4
VT27	Group6/VT4
VT28	Group7/VT4

2.4.3 XCVT Hosting DS3XM-6 or DS3XM-12

A DS3XM card can demultiplex (map down to a lower rate) M13-mapped DS-3 signals into 28 DS-1s that are then mapped to VT1.5 payloads. The VT1.5s can then be cross-connected by the XCVT card. The XCVT card can host a maximum of 336 bidirectional VT1.5s.

2.4.4 XCVT Card-Level Indicators

Table 2-15 shows the two card-level LEDs on the XCVT card faceplate.

Table 2-15 XCVT Card-Level Indicators

Card-Level Indicators	Definition
Red FAIL LED	Indicates that the cards processor is not ready. Replace the card if the red FAIL LED persists.
ACT/STBY LED Green (Active) Amber (Standby)	Indicates whether the XCVT card is active and carrying traffic (green) or in standby mode to the active XCVT card (amber).

2.5 XC10G Card



Note

For hardware specifications, see the [“A.4.4 XC10G Card Specifications”](#) section on page A-12.

The 10 Gigabit Cross Connect (XC10G) card establishes connections at the STS-1 and VT levels. The XC10G provides STS-192 capacity to Slots 5, 6, 12, and 13, and STS-48 capacity to Slots 1 to 4 and 14 to 17. The XC10G allows up to four times the bandwidth of the XCVT cards. The XC10G provides a maximum of 576 STS-1 cross-connections through 1152 STS-1 ports. Any STS-1 on any port can be connected to any other port, meaning that the STS cross-connections are nonblocking.

[Figure 2-5](#) shows the XC10G faceplate and block diagram.

Figure 2-5 XC10G Faceplate and Block Diagram

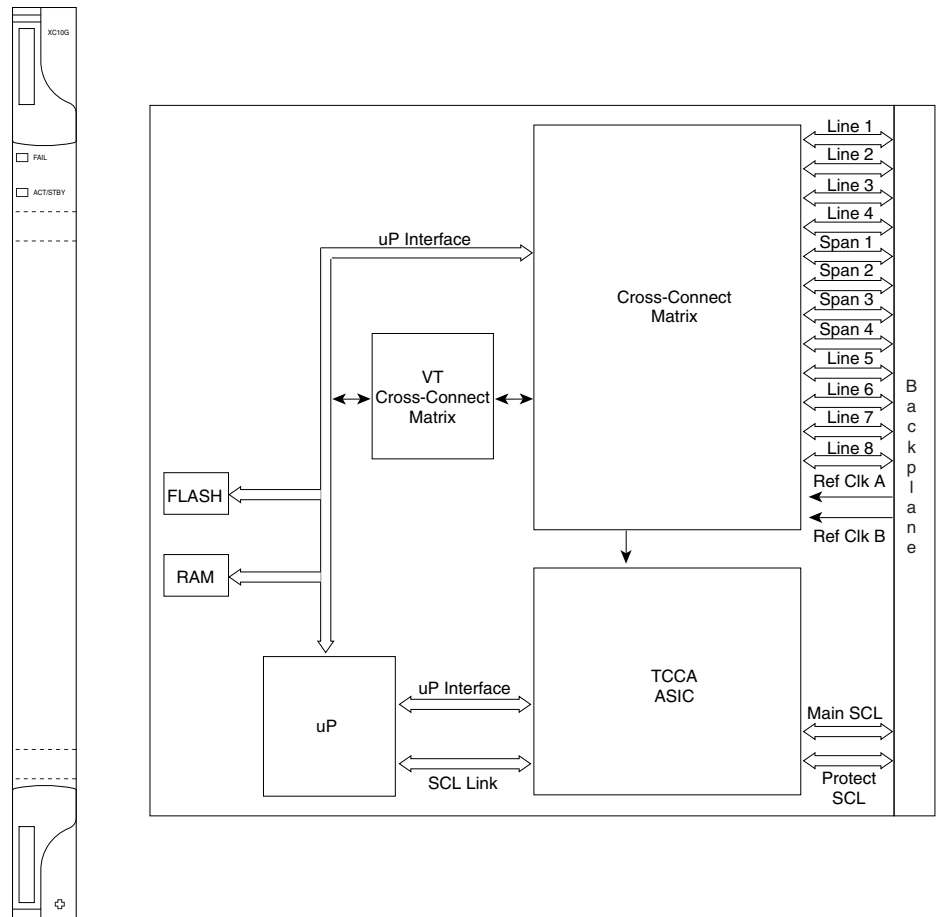

2.5.1 XC10G Functionality

The XC10G card manages up to 672 bidirectional VT1.5 ports and 1152 bidirectional STS-1 ports. The TCC2/TCC2P cards assign bandwidth to each slot on a per STS-1 or per VT1.5 basis.

Two cross-connect cards, installed in Slots 8 and 10, are required to operate the ONS 15454. You can establish cross-connect (circuit) information through the CTC. The cross-connect card establishes the proper internal cross-connect information and sends the setup information to the cross-connect card.

The XC10G card provides:

- 1152 STS bidirectional ports
- 576 STS bidirectional cross-connects
- 672 VT1.5 ports via 24 logical STS ports
- 336 VT1.5 bidirectional cross-connects
- Nonblocking at STS level
- STS-1/3c/6c/12c/48c/192c cross-connects

**Caution**

Do not operate the ONS 15454 with only one XCVT or XC10G card. Two cross-connect cards of the same type (either two XCVT or two XC10G cards) must always be installed.

Figure 2-6 shows the cross-connect matrix.

Figure 2-6 XC10G Cross-Connect Matrix

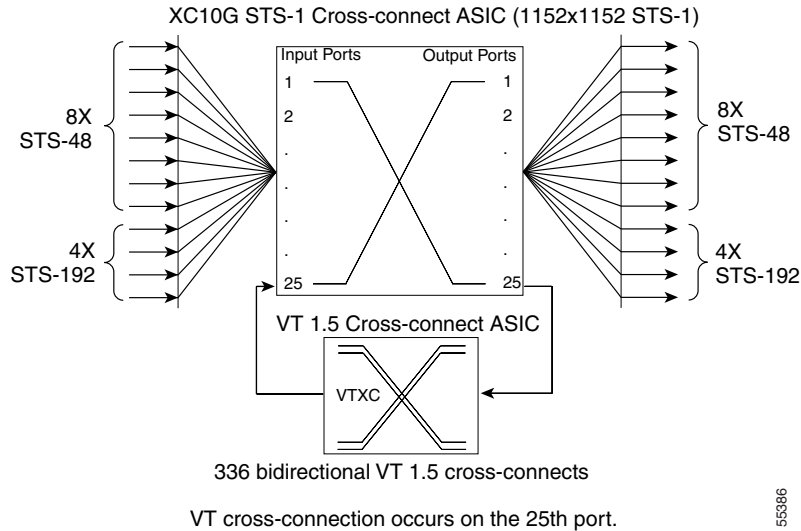

2.5.2 VT Mapping

The VT structure is designed to transport and switch payloads below the DS-3 rate. The ONS 15454 performs VT mapping according to Telcordia GR-253-CORE standards. Table 2-16 shows the VT numbering scheme for the ONS 15454 as it relates to the Telcordia standard.

Table 2-16 VT Mapping

ONS 15454 VT Number	Telcordia Group/VT Number
VT1	Group1/VT1
VT2	Group2/VT1
VT3	Group3/VT1
VT4	Group4/VT1
VT5	Group5/VT1
VT6	Group6/VT1
VT7	Group7/VT1
VT8	Group1/VT2
VT9	Group2/VT2
VT10	Group3/VT2
VT11	Group4/VT2

Table 2-16 VT Mapping (continued)

ONS 15454 VT Number	Telcordia Group/VT Number
VT12	Group5/VT2
VT13	Group6/VT2
VT14	Group7/VT2
VT15	Group1/VT3
VT16	Group2/VT3
VT17	Group3/VT3
VT18	Group4/VT3
VT19	Group5/VT3
VT20	Group6/VT3
VT21	Group7/VT3
VT22	Group1/VT4
VT23	Group2/VT4
VT24	Group3/VT4
VT25	Group4/VT4
VT26	Group5/VT4
VT27	Group6/VT4
VT28	Group7/VT4

2.5.3 XC10G Hosting DS3XM-6 or DS3XM-12

A DS3XM card can demultiplex (map down to a lower rate) M13-mapped DS-3 signals into 28 DS-1s that are then mapped to VT1.5 payloads. The VT1.5s can then be cross-connected by the XC10G card. The XC10G card can host a maximum of 336 bidirectional VT1.5s.

2.5.4 XC10G Card-Level Indicators

Table 2-17 describes the two card-level LEDs on the XC10G faceplate.

Table 2-17 XC10G Card-Level Indicators

Card-Level Indicators	Definition
Red FAIL LED	Indicates that the cards processor is not ready. This LED illuminates during reset. The FAIL LED flashes during the boot process. Replace the card if the red FAIL LED persists.
ACT/STBY LED Green (Active) Amber (Standby)	Indicates whether the XC10G is active and carrying traffic (green), or in standby mode to the active XC10G card (amber).

2.5.5 XCVT/XC10G/XC-VXC-10G Compatibility

The XC10G and XC-VXC-10G cards support the same features as the XCVT card. The XC10G or XC-VXC-10G cards are required for OC-192, OC-48 any-slot (AS), OC3-8, and OC12-4 operation. Do not use the XCVT card if you are using an OC-192, OC3-8, or OC12-4 card or if you install an OC-48 AS card in Slots 1 to 4 or 14 to 17.

**Note**

A configuration mismatch alarm occurs when an XCVT cross-connect card co-exists with an OC-192, OC3-8, or OC12-4 card placed in Slots 5, 6, 12, or 13 or with an OC-48 card placed in Slots 1 to 4 or 14 to 17.

If you are using Ethernet cards, the E1000-2-G or the E100T-G must be used when the XC10G or XC-VXC-10G cross-connect card is in use. Do not pair an XCVT card with an XC10G or XC-VXC-10G card. When upgrading from an XCVT to the XC10G or XC-VXC-10G card, refer to the “Upgrade Cards and Spans” chapter in the *Cisco ONS 15454 Procedure Guide* for more information.

2.6 XC-VXC-10G Card

**Note**

For hardware specifications, see the [“A.4.5 XC-VXC-10G Card Specifications”](#) section on page A-13.

The XC-VXC-10G card establishes connections at the STS and VT levels. The XC-VXC-10G provides STS-192 capacity to Slots 5, 6, 12, and 13, and STS-48 capacity to Slots 1 to 4 and 14 to 17. Any STS-1 on any port can be connected to any other port, meaning that the STS cross-connections are nonblocking.

[Figure 2-7](#) shows the XC-VXC-10G faceplate and block diagram.

Figure 2-7 XC-VXC-10G Faceplate and Block Diagram

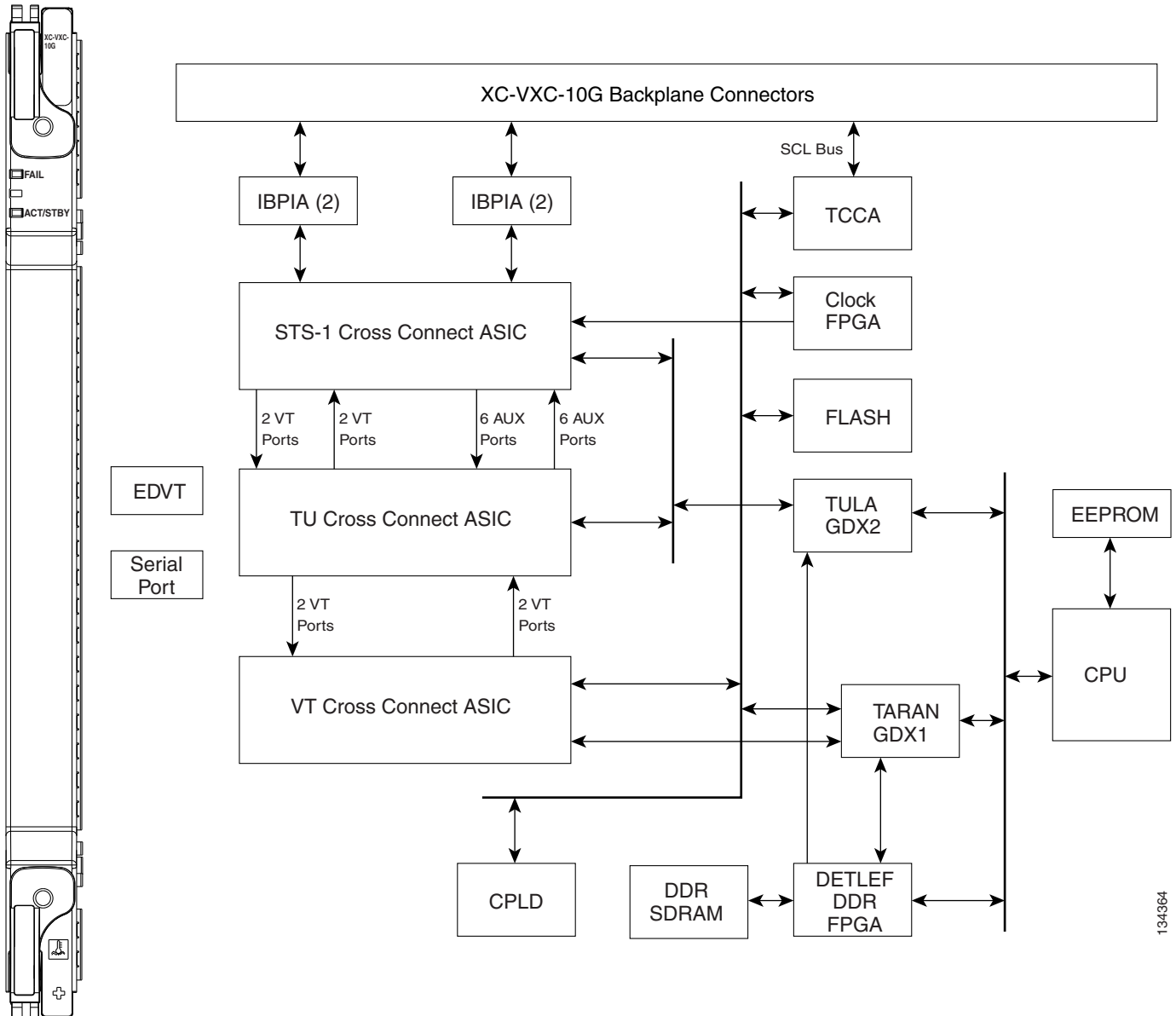

2.6.1 XC-VXC-10G Functionality

The XC-VXC-10G card manages up to 1152 bidirectional high-order STS-1 ports. In addition, it is able to simultaneously manage one of the following low-order VT cross-connect arrangements:

- 2688 bidirectional VT1.5 low-order ports, or
- 2016 VT2 low-order ports, or
- 1344 bidirectional VT1.5 ports and 1008 bidirectional VT2 ports (mixed grooming)

The TCC2/TCC2P card assigns bandwidth to each slot on a per STS-1, per VT1.5, or per VT2 basis. The switch matrices are fully crosspoint and broadcast supporting.

At the STS level (high-order cross-connect), the XC-VXC-10G is always non-blocking (any STS-1 from the system can be cross-connected to any other STS-1 without limitation up to 1152 bidirectional STS-1 ports (576 STS-1 cross-connects)).

In addition, for “mixed” VT1.5 and VT2 grooming, 50% of the available VT resources (ports) are allocated to each VT circuit type. The following three modes are supported (only one mode is available at a time):

- Mode 1: full VT1.5 cross-connect, which is 2688 bidirectional VT1.5 ports (1344 bidirectional VT1.5 cross-connects)
- Mode 2: full VT2 cross-connect, which is 2016 bidirectional VT2 ports (1008 bidirectional VT2 cross-connects)
- Mode 3 (mixed grooming): 50% VT1.5 and 50% VT2 XC, which is 1344 bidirectional VT1.5 ports and 1008 bidirectional VT2 ports (672 bidirectional VT1.5 and 504 VT2 bidirectional cross-connects)

The XC-VXC-10G card provides:

- 1152 STS bidirectional ports
- 576 STS bidirectional cross-connects
- 2688 VT1.5 ports via 96 logical STS ports
- 1344 VT1.5 bidirectional cross-connects
- 2016 VT2 ports via 96 logical STS ports
- 1008 VT2 bidirectional cross-connects
- Mixed grooming (50% VT1.5 and 50% VT2)
- Nonblocking at the STS level
- VT1.5, VT2, and STS-1/3c/6c/12c/48c/192c cross-connects



Note

VT 2 circuit provisioning works between optical cards and the DS3/EC1-48 card (EC1 ports, not the ports provisioned for DS3)

The XC-VXC-10G supports errorless side switches (switching from one XC-VXC-10G on one side of the shelf to the other XC-VXC-10G on the other side of the shelf) when the switch is initiated through software and the shelf is equipped with TCC2/TCC2P cards.

Cross-connect and provisioning information is established through the user interface on the TCC2/TCC2P card. In turn, the TCC2/TCC2P card establishes the proper internal cross-connect information and relays the setup information to the XC-VXC-10G card so that the proper cross-connection is established within the system.

The XC-VXC-10G card is deployed in Slots 8 or 10. Upgrading a system to an XC-VXC-10G from an earlier cross-connect module type is performed in-service, with hitless operation (less than 50-ms impact to any traffic). The XC-VXC-10G can be used with either the standard ANSI shelf assembly (15454-SA-ANSI) or high-density shelf assembly (15454-SA-HD).



Caution

Do not operate the ONS 15454 with only one XC-VXC-10G cross-connect card. Two cross-connect cards must always be installed.

Figure 2-8 shows the XC-VXC-10G cross-connect matrix.

Figure 2-8 XC-VXC-10G Cross-Connect Matrix

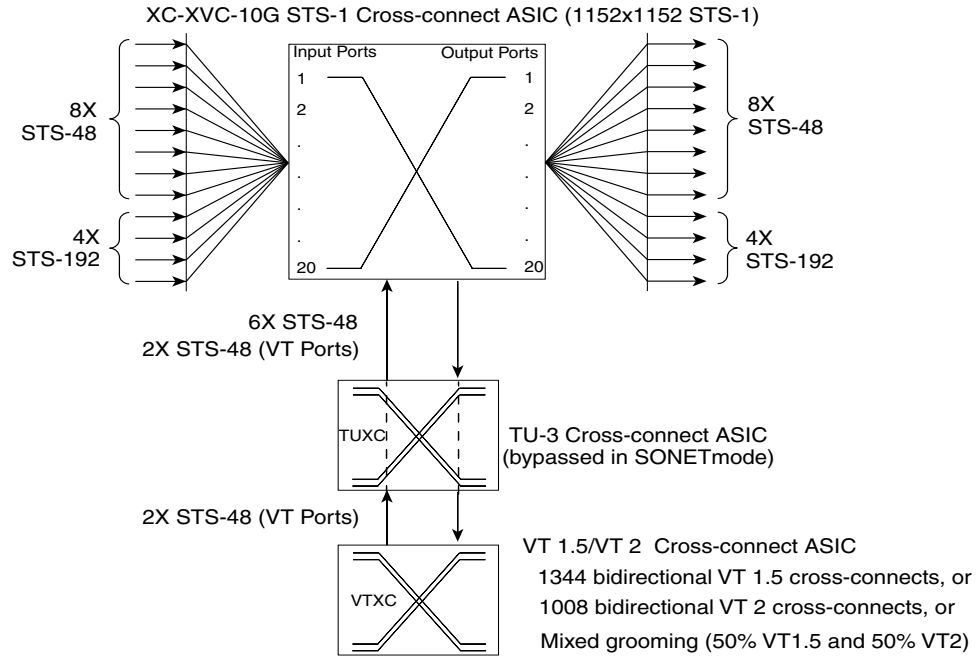

2.6.2 VT Mapping

The VT structure is designed to transport and switch payloads below the DS-3 rate. The ONS 15454 performs VT mapping according to Telcordia GR-253-CORE standards. Table 2-16 shows the VT numbering scheme for the ONS 15454 as it relates to the Telcordia standard.

Table 2-18 VT Mapping

ONS 15454 VT Number	Telcordia Group/VT Number
VT1	Group1/VT1
VT2	Group2/VT1
VT3	Group3/VT1
VT4	Group4/VT1
VT5	Group5/VT1
VT6	Group6/VT1
VT7	Group7/VT1
VT8	Group1/VT2
VT9	Group2/VT2
VT10	Group3/VT2
VT11	Group4/VT2
VT12	Group5/VT2
VT13	Group6/VT2

Table 2-18 VT Mapping (continued)

ONS 15454 VT Number	Telcordia Group/VT Number
VT14	Group7/VT2
VT15	Group1/VT3
VT16	Group2/VT3
VT17	Group3/VT3
VT18	Group4/VT3
VT19	Group5/VT3
VT20	Group6/VT3
VT21	Group7/VT3
VT22	Group1/VT4
VT23	Group2/VT4
VT24	Group3/VT4
VT25	Group4/VT4
VT26	Group5/VT4
VT27	Group6/VT4
VT28	Group7/VT4

2.6.3 XC-VXC-10G Hosting DS3XM-6 or DS3XM-12

A DS3XM card can demultiplex (map down to a lower rate) M13-mapped DS-3 signals into 28 DS-1s that are then mapped to VT1.5 payloads. The VT1.5s can then be cross-connected by the XC-VXC-10G card. The XC-VXC-10G card can host a maximum of 1344 bidirectional VT1.5s.

2.6.4 XC-VXC-10G Card-Level Indicators

Table 2-19 describes the two card-level LEDs on the XC-VXC-10G faceplate.

Table 2-19 XC-VXC-10G Card-Level Indicators

Card-Level Indicators	Definition
Red FAIL LED	Indicates that the cards processor is not ready. This LED illuminates during reset. The FAIL LED flashes during the boot process. Replace the card if the red FAIL LED persists.
ACT/STBY LED Green (Active) Amber (Standby)	Indicates whether the XC10G is active and carrying traffic (green), or in standby mode to the active XC10G card (amber).

2.6.5 XC-VXC-10G Compatibility

The XC-VXC-10G card supports the same features as the XC10G card. Either the XC10G or XC-VXC-10G card is required for OC-192, OC3-8, and OC12-4 operation and OC-48 AS operation.

If you are using Ethernet cards, the E1000-2-G or the E100T-G must be used when the XC-VXC-10G cross-connect card is in use. When upgrading from an XC10G card to an XC-VXC-10G card, refer to the “Upgrade Cards and Spans” chapter in the *Cisco ONS 15454 Procedure Guide* for more information. Also refer to the “[2.1.2 Card Compatibility](#)” section on page 2-3.

2.7 AIC-I Card

**Note**

For hardware specifications, see the “[A.4.6 AIC-I Card Specifications](#)” section on page A-13.

The optional Alarm Interface Controller–International (AIC-I) card provides customer-defined (environmental) alarms and controls and supports local and express orderwire. It provides 12 customer-defined input and 4 customer-defined input/output contacts. The physical connections are through the backplane wire-wrap pin terminals. If you use the additional AEP, the AIC-I card can support up to 32 inputs and 16 outputs, which are connected on the AEP connectors. A power monitoring function monitors the supply voltage (–48 VDC). [Figure 2-9](#) shows the AIC-I faceplate and a block diagram of the card.

Figure 2-9 AIC-I Faceplate and Block Diagram

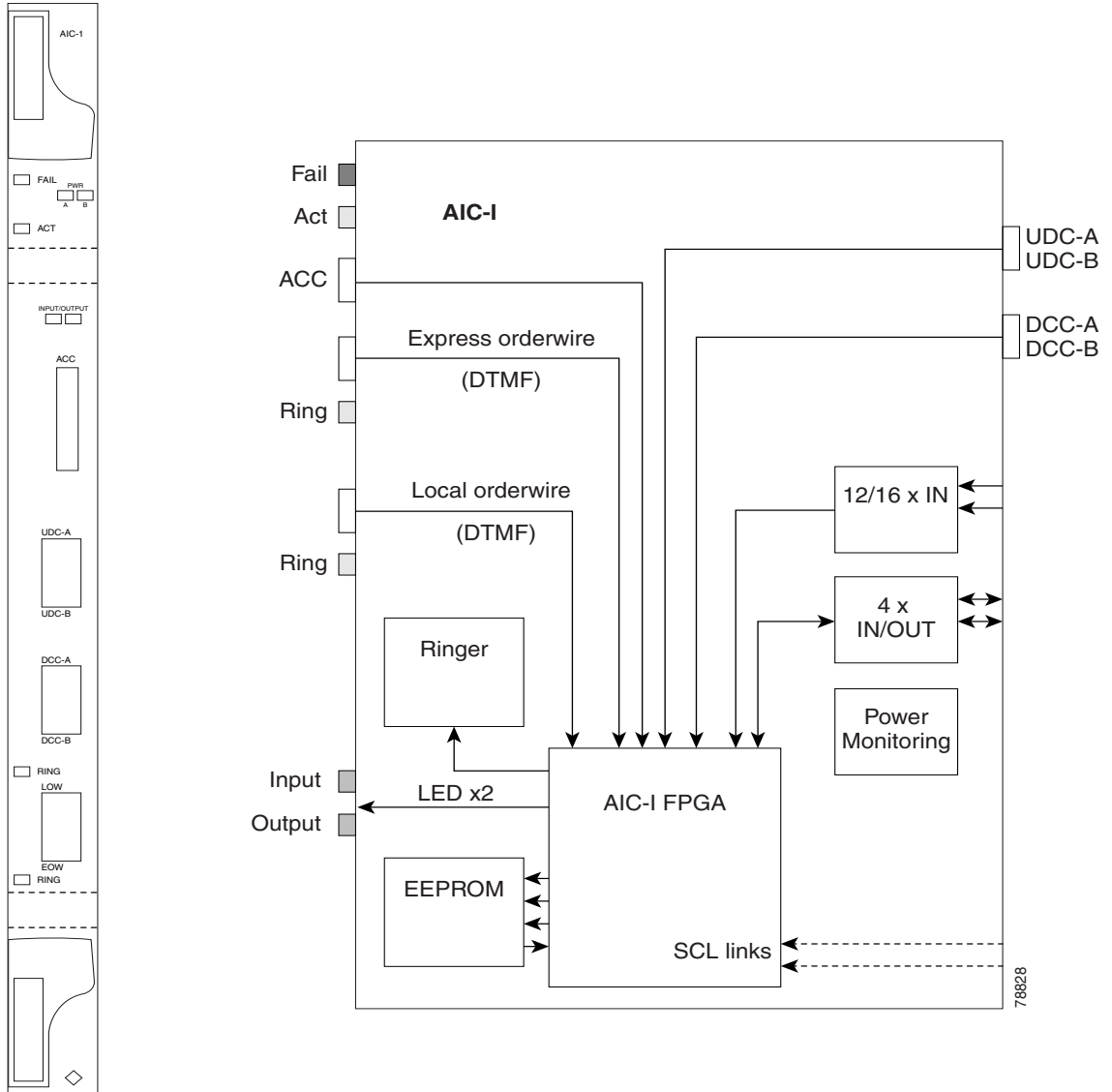

2.7.1 AIC-I Card-Level Indicators

Table 2-20 describes the eight card-level LEDs on the AIC-I card faceplate.

Table 2-20 AIC-I Card-Level Indicators

Card-Level LEDs	Description
Red FAIL LED	Indicates that the cards processor is not ready. The FAIL LED is on during Reset and flashes during the boot process. Replace the card if the red FAIL LED persists.
Green ACT LED	Indicates the AIC-I card is provisioned for operation.

Table 2-20 AIC-I Card-Level Indicators (continued)

Card-Level LEDs	Description
Green/Red PWR A LED	The PWR A LED is green when a supply voltage within a specified range has been sensed on supply input A. It is red when the input voltage on supply input A is out of range.
Green/Red PWR B LED	The PWR B LED is green when a supply voltage within a specified range has been sensed on supply input B. It is red when the input voltage on supply input B is out of range.
Amber INPUT LED	The INPUT LED is amber when there is an alarm condition on at least one of the alarm inputs.
Amber OUTPUT LED	The OUTPUT LED is amber when there is an alarm condition on at least one of the alarm outputs.
Green RING LED	The RING LED on the local orderwire (LOW) side is flashing green when a call is received on the LOW.
Green RING LED	The RING LED on the express orderwire (EOW) side is flashing green when a call is received on the EOW.

2.7.2 External Alarms and Controls

The AIC-I card provides input/output alarm contact closures. You can define up to twelve external alarm inputs and 4 external alarm inputs/outputs (user configurable). The physical connections are made using the backplane wire-wrap pins. See the “[1.12 Alarm Expansion Panel](#)” section on page 1-55 for information about increasing the number of input/output contacts.

LEDs on the front panel of the AIC-I indicate the status of the alarm lines, one LED representing all of the inputs and one LED representing all of the outputs. External alarms (input contacts) are typically used for external sensors such as open doors, temperature sensors, flood sensors, and other environmental conditions. External controls (output contacts) are typically used to drive visual or audible devices such as bells and lights, but they can control other devices such as generators, heaters, and fans.

You can program each of the twelve input alarm contacts separately. You can program each of the sixteen input alarm contacts separately. Choices include:

- Alarm on Closure or Alarm on Open
- Alarm severity of any level (Critical, Major, Minor, Not Alarmed, Not Reported)
- Service Affecting or Non-Service Affecting alarm-service level
- 63-character alarm description for CTC display in the alarm log. You cannot assign the fan-tray abbreviation for the alarm; the abbreviation reflects the generic name of the input contacts. The alarm condition remains raised until the external input stops driving the contact or you unprovision the alarm input.

You cannot assign the fan-tray abbreviation for the alarm; the abbreviation reflects the generic name of the input contacts. The alarm condition remains raised until the external input stops driving the contact or you provision the alarm input.

The output contacts can be provisioned to close on a trigger or to close manually. The trigger can be a local alarm severity threshold, a remote alarm severity, or a virtual wire:

- Local NE alarm severity: A hierarchy of Not Reported, Not Alarmed, Minor, Major, or Critical alarm severities that you set to cause output closure. For example, if the trigger is set to Minor, a Minor alarm or above is the trigger.
- Remote NE alarm severity: Same as the local network element (NE) alarm severity but applies to remote alarms only.
- Virtual wire entities: You can provision any environmental alarm input to raise a signal on any virtual wire on external outputs 1 through 4 when the alarm input is an event. You can provision a signal on any virtual wire as a trigger for an external control output.

You can also program the output alarm contacts (external controls) separately. In addition to provisionable triggers, you can manually force each external output contact to open or close. Manual operation takes precedence over any provisioned triggers that might be present.

**Note**

The number of inputs and outputs can be increased using the AEP. The AEP is connected to the shelf backplane and requires an external wire-wrap panel.

2.7.3 Orderwire

Orderwire allows a craftsperson to plug a phoneset into an ONS 15454 and communicate with craftspersons working at other ONS 15454s or other facility equipment. The orderwire is a pulse code modulation (PCM) encoded voice channel that uses E1 or E2 bytes in section/line overhead.

The AIC-I allows simultaneous use of both local (section overhead signal) and express (line overhead signal) orderwire channels on an SDH ring or particular optics facility. Express orderwire also allows communication via regeneration sites when the regenerator is not a Cisco device.

You can provision orderwire functions with CTC similar to the current provisioning model for DCC/GCC channels. In CTC, you provision the orderwire communications network during ring turn-up so that all NEs on the ring can reach one another. Orderwire terminations (that is, the optics facilities that receive and process the orderwire channels) are provisionable. Both express and local orderwire can be configured as on or off on a particular SONET facility. The ONS 15454 supports up to four orderwire channel terminations per shelf. This allows linear, single ring, dual ring, and small hub-and-spoke configurations. Keep in mind that orderwire is not protected in ring topologies such as bidirectional line switched rings (BLSRs) and path protection configurations.

**Caution**

Do not configure orderwire loops. Orderwire loops cause feedback that disables the orderwire channel.

The ONS 15454 implementation of both local and express orderwire is broadcast in nature. The line acts as a party line. Anyone who picks up the orderwire channel can communicate with all other participants on the connected orderwire subnetwork. The local orderwire party line is separate from the express orderwire party line. Up to four OC-N facilities for each local and express orderwire are provisionable as orderwire paths.

**Note**

The OC3 IR 4/STM1 SH 1310 card does not support the express orderwire channel.

The AIC-I supports selective dual tone multifrequency (DTMF) dialing for telephony connectivity, which causes one AIC-I card or all ONS 15454 AIC-I cards on the orderwire subnetwork to “ring.” The ringer/buzzer resides on the AIC-I. There is also a “ring” LED that mimics the AIC-I ringer. It flashes when a call is received on the orderwire subnetwork. A party line call is initiated by pressing *0000 on the DTMF pad. Individual dialing is initiated by pressing * and the individual four-digit number on the DTMF pad.

Table 2-21 shows the pins on the orderwire connector that correspond to the tip and ring orderwire assignments.

Table 2-21 Orderwire Pin Assignments

RJ-11 Pin Number	Description
1	Four-wire receive ring
2	Four-wire transmit tip
3	Two-wire ring
4	Two-wire tip
5	Four-wire transmit ring
6	Four-wire receive tip

When provisioning the orderwire subnetwork, make sure that an orderwire loop does not exist. Loops cause oscillation and an unusable orderwire channel.

Figure 2-10 shows the standard RJ-11 connectors used for orderwire ports. Use a shielded RJ-11 cable.

Figure 2-10 RJ-11 Connector

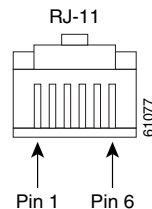

2.7.4 Power Monitoring

The AIC-I card provides a power monitoring circuit that monitors the supply voltage of –48 VDC for presence, undervoltage, or overvoltage.

2.7.5 User Data Channel

The user data channel (UDC) features a dedicated data channel of 64 kbps (F1 byte) between two nodes in an ONS 15454 network. Each AIC-I card provides two user data channels, UDC-A and UDC-B, through separate RJ-11 connectors on the front of the AIC-I card. Use an unshielded RJ-11 cable. Each UDC can be routed to an individual optical interface in the ONS 15454. For UDC circuit provisioning, refer to the “Create Circuits and VT Tunnels” chapter in the *Cisco ONS 15454 Procedure Guide*.

The UDC ports are standard RJ-11 receptacles. Table 2-22 lists the UDC pin assignments.

Table 2-22 UDC Pin Assignments

RJ-11 Pin Number	Description
1	For future use
2	TXN
3	RXN
4	RXP
5	TXP
6	For future use

2.7.6 Data Communications Channel

The DCC features a dedicated data channel of 576 kbps (D4 to D12 bytes) between two nodes in an ONS 15454 network. Each AIC-I card provides two DCCs, DCC-A and DCC-B, through separate RJ-45 connectors on the front of the AIC-I card. Use a shielded RJ-45 cable. Each DCC can be routed to an individual optical interface in the ONS 15454.

The DCC ports are synchronous serial interfaces. The DCC ports are standard RJ-45 receptacles. [Table 2-23](#) lists the DCC pin assignments.

Table 2-23 DCC Pin Assignments

RJ-45 Pin Number	Description
1	TCLKP
2	TCLKN
3	TXP
4	TXN
5	RCLKP
6	RCLKN
7	RXP
8	RXN



CHAPTER 3

Electrical Cards

This chapter describes Cisco ONS 15454 electrical card features and functions. For installation and card turn-up procedures, refer to the *Cisco ONS 15454 Procedure Guide*. For information on the electrical interface assemblies (EIAs), see the “[1.5 Electrical Interface Assemblies](#)” section on page 1-14.

Chapter topics include:

- [3.1 Electrical Card Overview, page 3-1](#)
- [3.2 EC1-12 Card, page 3-3](#)
- [3.3 DS1-14 and DS1N-14 Cards, page 3-5](#)
- [3.4 DS1/E1-56 Card, page 3-9](#)
- [3.5 DS3-12 and DS3N-12 Cards, page 3-12](#)
- [3.6 DS3/EC1-48 Card, page 3-15](#)
- [3.7 DS3i-N-12 Card, page 3-18](#)
- [3.8 DS3-12E and DS3N-12E Cards, page 3-20](#)
- [3.9 DS3XM-6 Card, page 3-24](#)
- [3.10 DS3XM-12 Card, page 3-26](#)

3.1 Electrical Card Overview

Each card is marked with a symbol that corresponds to a slot (or slots) on the ONS 15454 shelf assembly. The cards are then installed into slots displaying the same symbols. See the “[1.17 Cards and Slots](#)” section on page 1-68 for a list of slots and symbols.

3.1.1 Card Summary

[Table 3-1](#) lists the Cisco ONS 15454 electrical cards.

Table 3-1 Cisco ONS 15454 Electrical Cards

Card Name	Description	For Additional Information
EC1-12	The EC1-12 card provides 12 Telcordia-compliant, GR-253 STS-1 electrical ports per card. Each port operates at 51.840 Mbps over a single 750-ohm, 728A or equivalent coaxial span.	See the “ 3.2 EC1-12 Card ” section on page 3-3.
DS1-14	The DS1-14 card provides 14 Telcordia-compliant GR-499 DS-1 ports. Each port operates at 1.544 Mbps over a 100-ohm, twisted-pair copper cable.	See the “ 3.3 DS1-14 and DS1N-14 Cards ” section on page 3-5.
DS1N-14	The DS1N-14 card supports the same features as the DS1-14 card but can also provide 1:N (N <= 5) protection.	See the “ 3.3 DS1-14 and DS1N-14 Cards ” section on page 3-5.
DS1/E1-56	The DS1/E1-56 card provides 56 Telcordia-compliant, GR-499 DS-1 ports per card, or 56 E1 ports per card. Each port operates at 1.544 Mbps (DS-1) or 2.048 Mbps (E1). The DS1/E1-56 card operates as a working or protect card in 1:N protection schemes, where N <= 2.	See the “ 3.4 DS1/E1-56 Card ” section on page 3-9.
DS3-12	The DS3-12 card provides 12 Telcordia-compliant GR-499 DS-3 ports per card. Each port operates at 44.736 Mbps over a single 75-ohm, 728A or equivalent coaxial span.	See the “ 3.5 DS3-12 and DS3N-12 Cards ” section on page 3-12.
DS3N-12	The DS3N-12 card supports the same features as the DS3-12 but can also provide 1:N (N <= 5) protection.	See the “ 3.5 DS3-12 and DS3N-12 Cards ” section on page 3-12.
DS3/EC1-48	The DS3/EC1-48 provides 48 Telcordia-compliant ports per card. Each port operates at 44.736 Mbps over a single 75-ohm, 728A or equivalent coaxial span.	See the “ 3.6 DS3/EC1-48 Card ” section on page 3-15.
DS3-12E	The DS3-12E card provides 12 Telcordia-compliant ports per card. Each port operates at 44.736 Mbps over a single 75-ohm, 728A or equivalent coaxial span. The DS3-12E card provides enhanced performance monitoring functions.	See the “ 3.8 DS3-12E and DS3N-12E Cards ” section on page 3-20.
DS3N-12E	The DS3N-12E card supports the same features as the DS3-12E but can also provide 1:N (N <= 5) protection.	See the “ 3.8 DS3-12E and DS3N-12E Cards ” section on page 3-20.
DS3XM-6 (Transmux)	The DS3XM-6 card provides six Telcordia-compliant GR-499-CORE M13 multiplexing functions. The DS3XM-6 converts six framed DS-3 network connections to 28x6 or 168 VT1.5s.	See the “ 3.9 DS3XM-6 Card ” section on page 3-24.
DS3XM-12 (Transmux)	The DS3XM-12 card provides 12 Telcordia-compliant GR-499-CORE M13 multiplexing functions. The DS3XM-12 converts twelve framed DS-3 network connections to 28x12 or 168 VT1.5s.	See the “ 3.10 DS3XM-12 Card ” section on page 3-26.

3.1.2 Card Compatibility

Table 3-2 lists the CTC software compatibility for each electrical card. See Table 2-4 on page 2-4 for a list of cross-connect cards that are compatible with each electrical card.



Note

“Yes” indicates that this card is fully or partially supported by the indicated software release. Refer to the individual card reference section for more information about software limitations for this card.

Table 3-2 Electrical Card Software Release Compatibility

Electrical Card	R2.2.2	R3.0.1	R3.1	R3.2	R3.3	R3.4	R4.0	R4.1	R4.5	R4.6	R4.7	R5.0	R6.0	R7.0
EC1-12	Yes	Yes	Yes	Yes	Yes	Yes	Yes	Yes	—	Yes	—	Yes	Yes	Yes
DS1-14	Yes	Yes	Yes	Yes	Yes	Yes	Yes	Yes	—	Yes	—	Yes	Yes	Yes
DS1N-14	Yes	Yes	Yes	Yes	Yes	Yes	Yes	Yes	—	Yes	—	Yes	Yes	Yes
DS1/E1-56	—	—	—	—	—	—	—	—	—	—	—	—	Yes	Yes
DS3-12	Yes	Yes	Yes	Yes	Yes	Yes	Yes	Yes	—	Yes	—	Yes	Yes	Yes
DS3N-12	Yes	Yes	Yes	Yes	Yes	Yes	Yes	Yes	—	Yes	—	Yes	Yes	Yes
DS3-12E	Yes	Yes	Yes	Yes	Yes	Yes	Yes	Yes	—	Yes	—	Yes	Yes	Yes
DS3N-12E	Yes	Yes	Yes	Yes	Yes	Yes	Yes	Yes	—	Yes	—	Yes	Yes	Yes
DS3XM-6 (Transmux)	Yes	Yes	Yes	Yes	Yes	Yes	Yes	Yes	—	Yes	—	Yes	Yes	Yes
DS3XM-12 (Transmux)	—	—	—	—	—	—	—	—	—	—	—	Yes	Yes	Yes
DS3/EC1-48	—	—	—	—	—	—	—	—	—	—	—	Yes	Yes	Yes
DS3i-N-12	—	—	—	—	—	—	—	Yes (4.1.2)	—	Yes	—	Yes	Yes	Yes

3.2 EC1-12 Card



Note

For hardware specifications, see the “A.5.1 EC1-12 Card Specifications” section on page A-15.

The EC1-12 card provides 12 Telcordia-compliant, GR-253 STS-1 electrical ports per card. Each port operates at 51.840 Mbps over a single 75-ohm, 728A or equivalent coaxial span.

STS path selection for UNEQ-P, AIS-P, and bit error rate (BER) thresholds is done on the SONET ring interfaces (optical cards) in conjunction with the STS cross-connect. The EC1-12 terminates but does not select the 12 working STS-1 signals from the backplane. The EC1-12 maps each of the 12 received EC1 signals into 12 STS-1s with visibility into the SONET path overhead.

An EC1-12 card can be 1:1 protected with another EC1-12 card but cannot protect more than one EC1-12 card. You must install the EC1-12 in an even-numbered slot to serve as a working card and in an odd-numbered slot to serve as a protect card.

3.2.1 EC1-12 Slots and Connectors

You can install the EC1-12 card in Slots 1 to 6 or 12 to 17 on the ONS 15454. Each EC1-12 interface features DSX-level (digital signal cross-connect frame) outputs supporting distances up to 450 feet (137 meters) depending on facility conditions. See the “[7.2 Electrical Card Protection and the Backplane](#)” section on page 7-5 for more information about electrical card slot protection and restrictions.

3.2.2 EC1-12 Faceplate and Block Diagram

Figure 3-1 shows the EC1-12 faceplate and a block diagram of the card.

Figure 3-1 EC1-12 Faceplate and Block Diagram

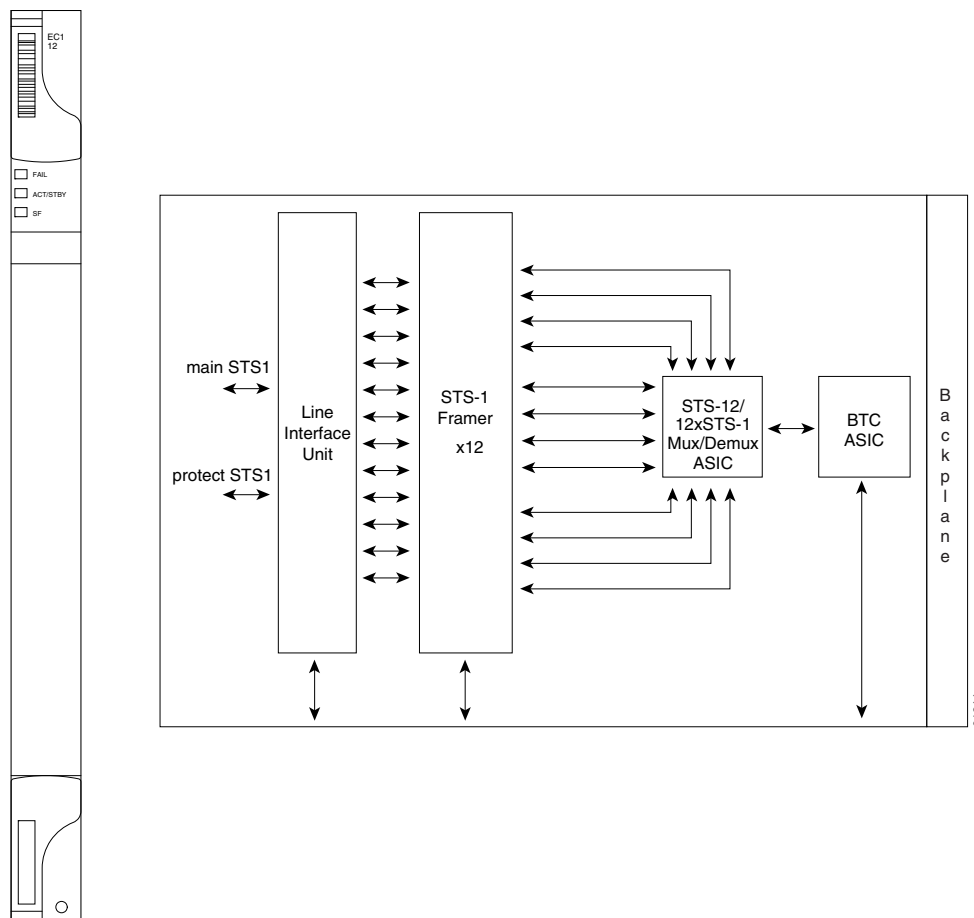

3.2.3 EC1-12 Hosted by XCVT, XC10G, or XC-VXC-10G

All 12 STS-1 payloads from an EC1-12 card are carried to the XCVT, XC10G, or XC-VXC-10G card where the payload is further aggregated for efficient transport. XCVT cards can host a maximum of 288 bidirectional STS-1s. The XC10G and XC-VXC-10G cards can host up to 1152 bidirectional STS-1s.

3.2.4 EC1-12 Card-Level Indicators

Table 3-3 describes the three card-level LEDs on the EC1-12 card.

Table 3-3 EC1-12 Card-Level Indicators

Card-Level Indicators	Description
Red FAIL LED	The red FAIL LED indicates that the EC1-12 card processor is not ready. Replace the unit if the FAIL LED persists.
Green ACT LED	The green ACT LED indicates that the EC1-12 card is operational and ready to carry traffic.
Amber SF LED	The amber SF LED indicates a signal failure or condition such as loss of signal (LOS), loss of frame (LOF) or high BER on one or more card ports.

3.2.5 EC1-12 Port-Level Indicators

You can obtain the status of the EC1-12 card ports by using the LCD screen on the ONS 15454 fan tray. Use the LCD to view the status of any port or card slot; the screen displays the number and severity of alarms for a given port or slot.

3.3 DS1-14 and DS1N-14 Cards



Note

For hardware specifications, see the “A.5.2 DS1-14 and DS1N-14 Card Specifications” section on page A-16.

The ONS 15454 DS1-14 card provides 14 Telcordia-compliant, GR-499 DS-1 ports. Each port operates at 1.544 Mbps over a 100-ohm, twisted-pair copper cable. The DS1-14 card can function as a working or protect card in 1:1 protection schemes and as a working card in 1:N protection schemes. Each DS1-14 port has digital signal cross-connect frame (DSX)-level outputs supporting distances up to 655 feet (200 meters).

The DS1-14 card supports 1:1 protection. The DS1-14 can be a working card in a 1:N protection scheme with the proper backplane EIA and wire-wrap or AMP Champ connectors. You can also provision the DS1-14 to monitor for line and frame errors in both directions.

You can group and map DS1-14 card traffic in STS-1 increments to any other card in an ONS 15454 except DS-3 cards. Each DS-1 is asynchronously mapped into a SONET VT1.5 payload and the card carries a DS-1 payload intact in a VT1.5. For performance monitoring purposes, you can gather bidirectional DS-1 frame-level information (LOF, parity errors, cyclic redundancy check [CRC] errors, and so on).

3.3.1 DS1N-14 Features and Functions

The DS1N-14 card supports the same features as the DS1-14 card in addition to enhanced protection schemes. The DS1N-14 is capable of 1:N ($N \leq 5$) protection with the proper backplane EIA and wire-wrap or AMP Champ connectors. The DS1N-14 card can function as a working or protect card in 1:1 or 1:N protection schemes.

If you use the DS1N-14 as a standard DS-1 card in a 1:1 protection group, you can install the DS1N-14 card in Slots 1 to 6 or 12 to 17 on the ONS 15454. If you use the card's 1:N functionality, you must install a DS1N-14 card in Slots 3 and 15. Each DS1N-14 port features DS-n-level outputs supporting distances of up to 655 feet (200 meters) depending on facility conditions.

3.3.2 DS1-14 and DS1N-14 Slot Compatibility

You can install the DS1-14 card in Slots 1 to 6 or 12 to 17 on the ONS 15454.

3.3.3 DS1-14 and DS1N-14 Faceplate and Block Diagram

[Figure 3-2](#) shows the DS1-14 faceplate and the block diagram of the card.

Figure 3-2 DS1-14 Faceplate and Block Diagram

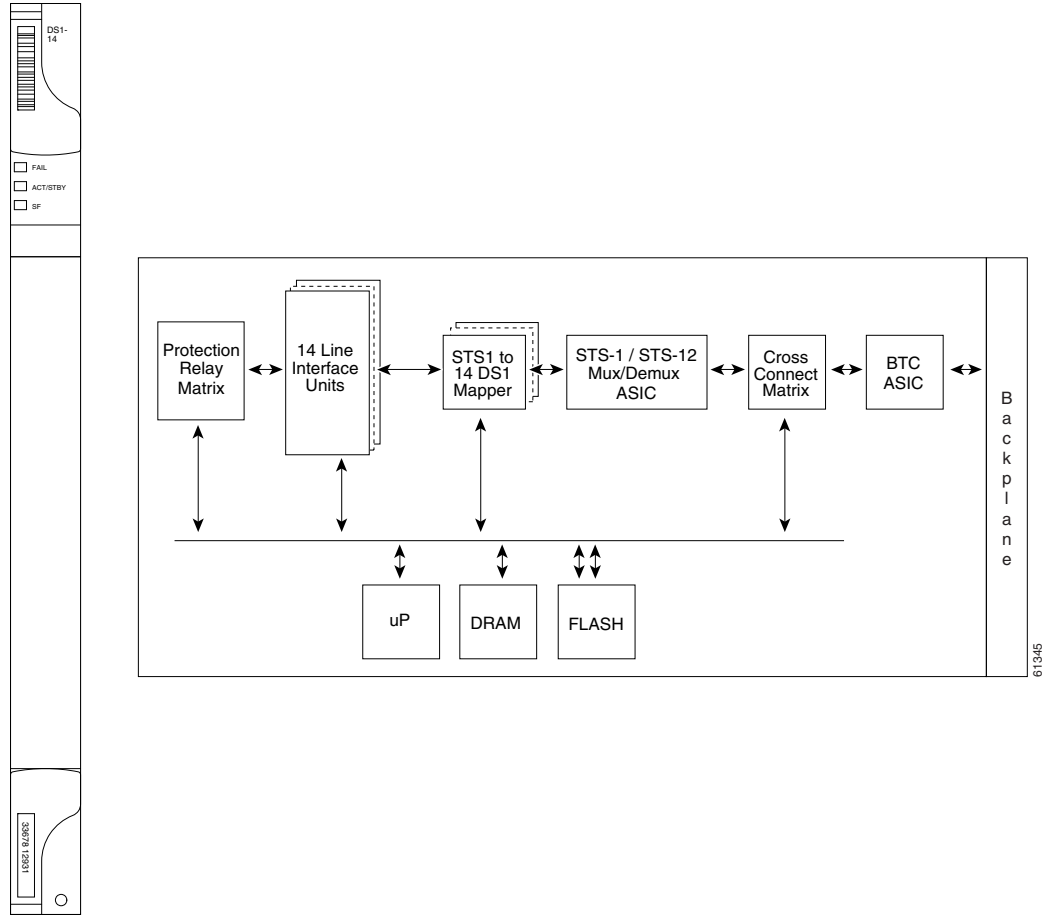
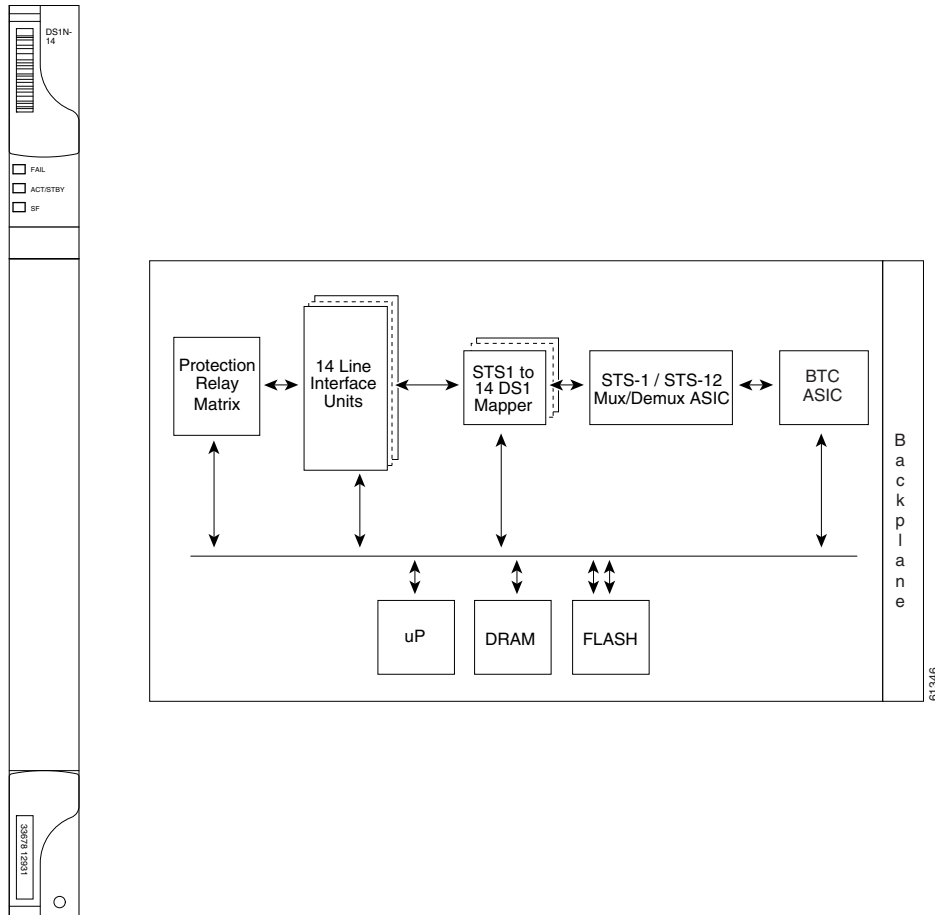

Figure 3-3 shows the DS1N-14 faceplate and a block diagram of the card.

Figure 3-3 DS1N-14 Faceplate and Block Diagram



3.3.4 DS1-14 and DS1N-14 Hosted by XCVT, XC10G, or XC-VXC-10G

All 14 VT1.5 payloads from DS1-14 and DS1N-14 cards are carried in a single STS-1 to the XCVT, XC10G, or XC-VXC-10G cards, where the payload is further aggregated for efficient STS-1 transport. The XC10G and XCVT cards manage up to 336 bidirectional VT1.5 ports. The XC-VXC-10G card can manage up to 2688 bidirectional VT1.5 ports

3.3.5 DS1-14 and DS1N-14 Card-Level Indicators

Table 3-4 describes the three card-level LEDs on the DS1-14 and DS1N-14 card faceplates.

Table 3-4 DS1-14 and DS1N-14 Card-Level Indicators

Card-Level Indicators	Description
Red FAIL LED	The red FAIL LED indicates that the card processor is not ready. Replace the card if the red FAIL LED persists.
ACT/STBY LED Green (Active) Amber (Standby)	The green/amber ACT/STBY LED indicates whether the card is operational and ready to carry traffic (green) or in standby mode (amber).
Amber SF LED	The amber SF LED indicates a signal failure or condition such as LOS, LOF, or high BERs on one or more card ports.

3.3.6 DS1-14 and DS1N-14 Port-Level Indicators

You can obtain the status of the DS1-14 and DS1N-14 card ports by using the LCD screen on the ONS 15454 fan-tray assembly. Use the LCD to view the status of any port or card slot; the screen displays the number and severity of alarms for a given port or slot.

3.4 DS1/E1-56 Card

Note

For hardware specifications, see the [“A.5.3 DS1/E1-56 Card Specifications”](#) section on page A-18.

The ONS 15454 DS1/E1-56 card provides 56 Telcordia-compliant, GR-499 DS-1 ports per card, or 56 E1 ports per card. Each port operates at 1.544 Mbps (DS-1) or 2.048 Mbps (E1). The DS1/E1-56 card operates as a working or protect card in 1:N protection schemes, where $N \leq 2$. The DS1/E1-56 card can be used with the XCVT, XC10G, or XC-VXC-10G cross-connect cards.

Note

The DS1/E1-56 card does not support VT-2 (virtual tributary-2) circuit creation on E1 ports.

Caution

When a protection switch moves traffic from the active (or working) DS1/E1-56 card to the standby (or protect) DS1/E1-56 card, ports on the now standby (or protect) card cannot be moved to Out of Service state. Traffic is dropped if the ports are in Out of Service state.

3.4.1 DS1/E1-56 Slots and Connectors

For SONET applications, the DS1/E1-56 card requires a high-density (HD) shelf (15454-SA-HD), UBIC EIA, and Software Release 6.0 or greater.

Note

The UBIC-H EIA supports the termination of both DS-1 and E-1 signals when used with the appropriate cables. The UBIC-V EIA only supports the termination of DS-1 signals.

**Note**

The DS1/E1-56 card supports an errorless software-initiated cross-connect card switch when used in a shelf equipped with XC-VXC-10G and TCC2/TCC2P cards.

You can install the DS1/E1-56 card in Slots 1 to 3 or 15 to 17 on the ONS 15454, but installing this card in certain slots will block the use of other slots. [Table 3-5](#) shows which slots become unusable for other electrical cards when the DS1/E1-56 card is installed in a particular slot.

Table 3-5 DS1/E1-56 Slot Restrictions

Slot	Additional Unusable Slots for Electrical Cards
1	5 and 6
2	3 or 4 (except another DS1/E1-56 protect card can be installed in Slot 3)
3	—
15	—
16	14 and 15 (except another DS1/E1-56 protect card can be installed in Slot 15)
17	12 and 13

With the proper backplane EIA, the card supports SCSI (UBIC) connectors. See the [“7.2 Electrical Card Protection and the Backplane”](#) section on page 7-5 for more information about electrical card slot protection and restrictions.

3.4.2 DS1/E1-56 Faceplate and Block Diagram

[Figure 3-4](#) shows the DS1/E1-56 faceplate and a block diagram of the card.

Figure 3-4 DS1/E1-56 Faceplate and Block Diagram

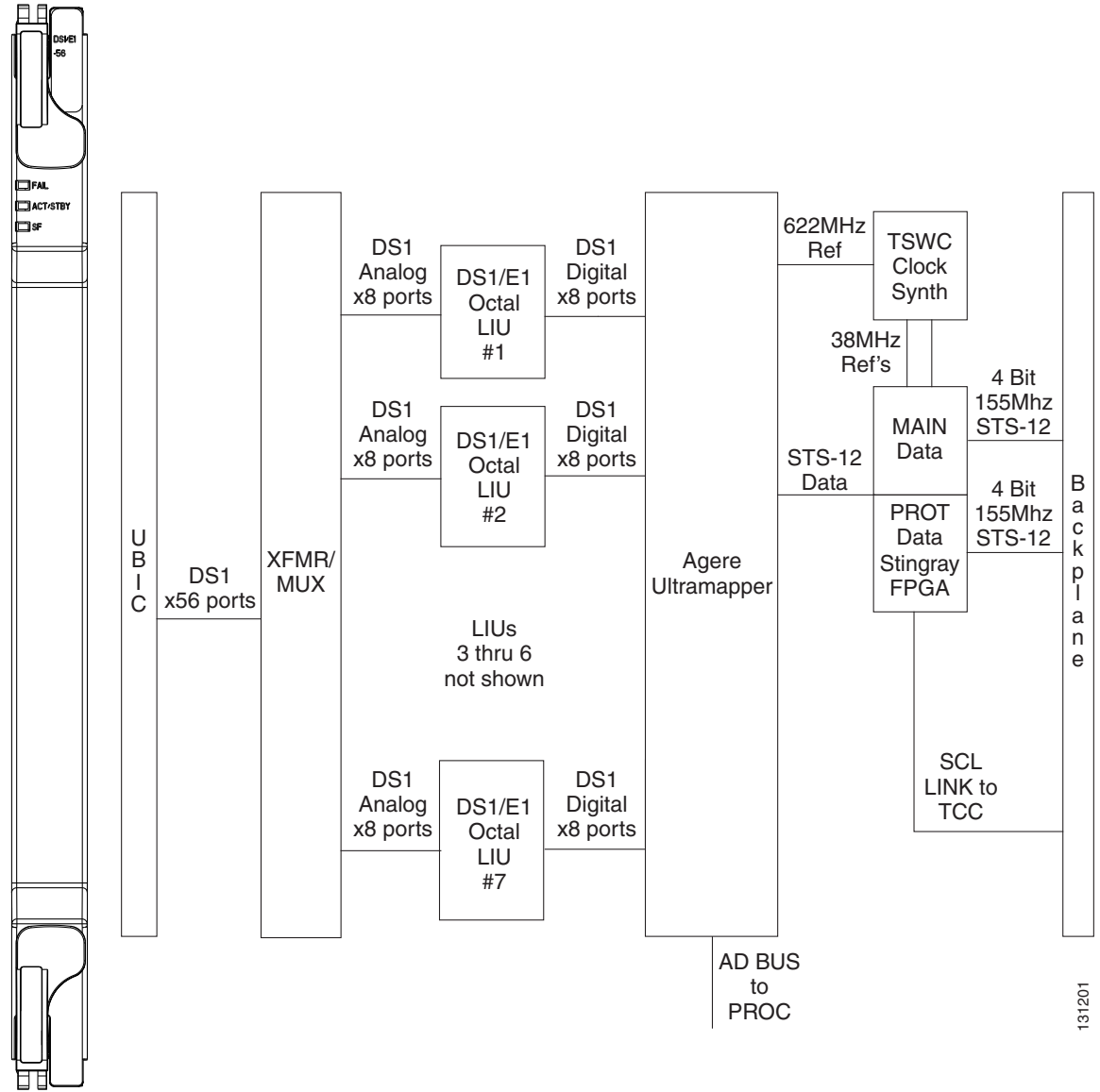

131201

3.4.3 DS1/E1-56 Card-Level Indicators

The DS1/E1-56 card has three card-level LED indicators (Table 3-6).

Table 3-6 DS1/E1-56 Card-Level Indicators

Card-Level Indicators	Description
Red FAIL LED	Indicates that the card processor is not ready. This LED is on during reset. The FAIL LED flashes during the boot process. Replace the card if the red FAIL LED persists in flashing.
ACT/STBY LED Green (Active) Amber (Standby)	When the ACT/STBY LED is green, the card is operational and ready to carry traffic. When the ACT/STBY LED is amber, the card is operational and in standby (protect) mode.
Amber SF LED	Indicates a signal failure or condition such as LOS or LOF on one or more card ports.

3.4.4 DS1/E1-56 Port-Level Indicators

You can obtain the status of the DS1/E1-56 card ports by using the LCD screen on the ONS 15454 fan-tray assembly. Use the LCD to view the status of any port or card slot; the screen displays the number and severity of alarms for a given port or slot.

3.5 DS3-12 and DS3N-12 Cards

Note

For hardware specifications, see the [“A.5.5 DS3-12 and DS3N-12 Card Specifications”](#) section on page A-20.

Note

Any new features that are available as part of this software release are not enabled for this card.

The ONS 15454 DS3-12 card provides 12 Telcordia-compliant, GR-499 DS-3 ports per card. Each port operates at 44.736 Mbps over a single 75-ohm 728A or equivalent coaxial span. The DS3-12 card operates as a working or protect card in 1:1 protection schemes and as a working card in 1:N protection schemes.

The DS3-12 card supports 1:1 protection with the proper backplane EIA. EIAs are available with BNC, SMB, or SCSI (UBIC) connectors.

Caution

When a protection switch moves traffic from the DS3-12 working/active card to the DS3-12 protect/standby card, ports on the now active/standby card cannot be taken out of service. Lost traffic can result if you take a port out of service, even if the DS3-12 standby card no longer carries traffic.

Other than protection capabilities, the DS3-12 and DS3N-12 cards are identical. The DS3N-12 can operate as the protect card in a 1:N (N <= 5) DS3 protection group. It has additional circuitry that is not present on the basic DS3-12 card that allows it to protect up to five working DS3-12 cards. The basic DS3-12 card can only function as the protect card for one other DS3-12 card.

3.5.1 DS3-12 and DS3N-12 Slots and Connectors

You can install the DS3-12 or DS3N-12 card in Slots 1 to 6 or 12 to 17 on the ONS 15454. Each DS3-12 or DS3N-12 card port features DSX-level outputs supporting distances up to 137 meters (450 feet) depending on facility conditions. With the proper backplane EIA, the card supports BNC or SMB connectors. See the “7.2 Electrical Card Protection and the Backplane” section on page 7-5 for more information about electrical card slot protection and restrictions.

3.5.2 DS3-12 and DS3N-12 Faceplate and Block Diagram

Figure 3-5 shows the DS3-12 faceplate and a block diagram of the card.

Figure 3-5 DS3-12 Faceplate and Block Diagram

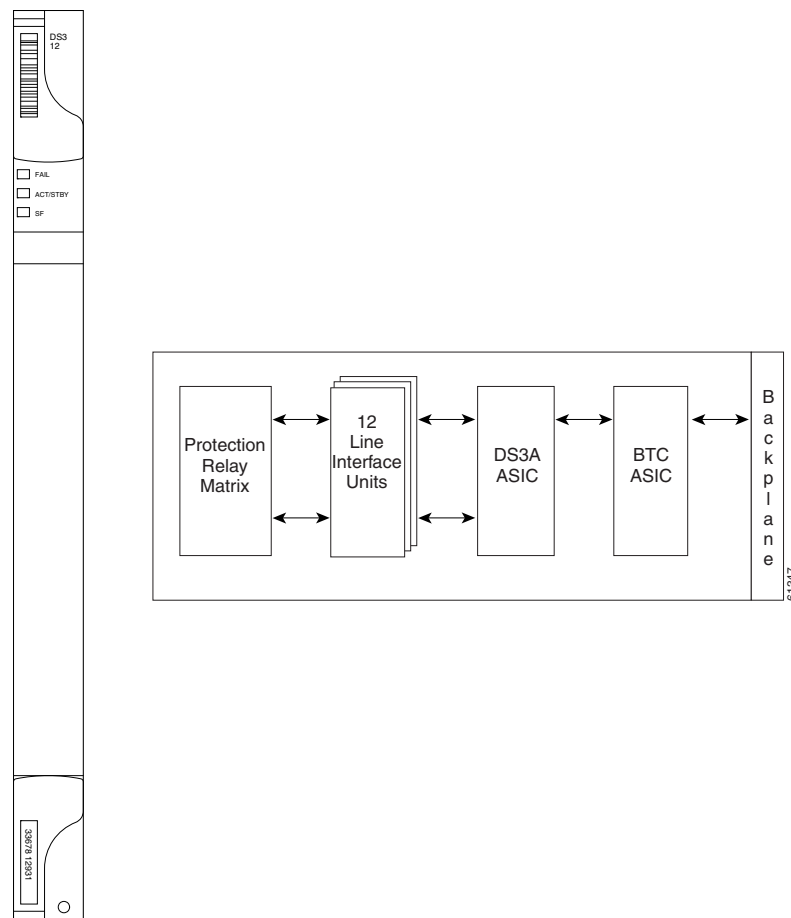
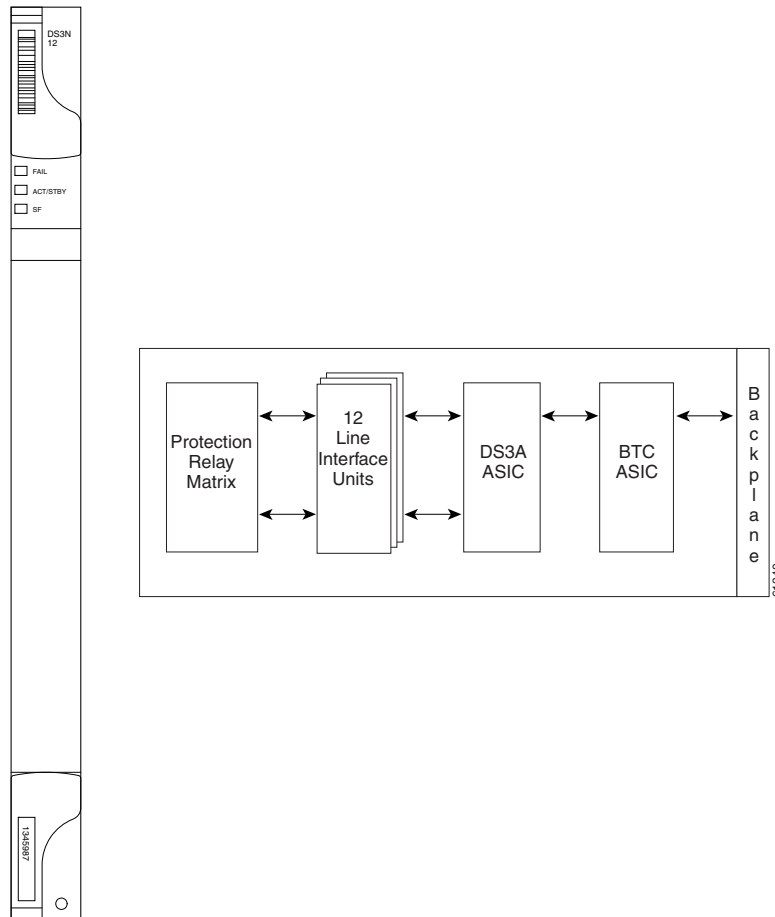

Figure 3-6 shows the DS3N-12 faceplate and a block diagram of the card.

Figure 3-6 DS3N-12 Faceplate and Block Diagram



3.5.3 DS3-12 and DS3N-12 Card-Level Indicators

Table 3-7 describes the three card-level LEDs on the DS3-12 and DS3N-12 card faceplates.

Table 3-7 DS3-12 and DS3N-12 Card-Level Indicators

Card-Level Indicators	Description
Red FAIL LED	The red FAIL LED indicates that the card processor is not ready. Replace the card if the red FAIL LED persists.
ACT/STBY LED Green (Active) Amber (Standby)	When the ACT/STBY LED is green, the card is operational and ready to carry traffic. When the ACT/STBY LED is amber, the card is operational and in standby (protect) mode.
Amber SF LED	The amber SF LED indicates a signal failure or condition such as port LOS.

3.5.4 DS3-12 and DS3N-12 Port-Level Indicators

You can find the status of the 12 DS3-12 and 12 DS3N-12 card ports by using the LCD screen on the ONS 15454 fan-tray assembly. Use the LCD to view the status of any port or card slot; the screen displays the number and severity of alarms for a given port or slot.

3.6 DS3/EC1-48 Card



Note

For hardware specifications, see the [“A.5.4 DS3/EC1-48 Card Specifications”](#) section on page A-19.

The ONS 15454 DS3/EC1-48 card provides 48 Telcordia-compliant, GR-499 DS-3 ports per card. Each port operates at 44.736 Mbps over a single 75-ohm 728A or equivalent coaxial span. The DS3/EC1-48 card operates as a working or protect card in 1:N protection schemes, where $N \leq 2$.



Caution

When a protection switch moves traffic from the DS3/EC1-48 working/active card to the DS3/EC1-48 protect/standby card, ports on the now active/standby card cannot be taken out of service. Lost traffic can result if you take a port out of service, even if the DS3/EC1-48 standby card no longer carries traffic.

3.6.1 DS3/EC1-48 Slots and Connectors

For SONET applications, the DS3/EC1-48 card requires an HD shelf (15454-SA-HD) and EIA (UBIC, MiniBNC); Software Release 5.0 or greater; and XC10G or XC-VXC-10G cards.



Note

The DS3/EC1-48 card supports an errorless software-initiated cross-connect card switch when used in a shelf equipped with XC-VXC-10G and TCC2/TCC2P cards.

You can install the DS3/EC1-48 card in Slots 1 to 3 or 15 to 17 on the ONS 15454, but installing this card in certain slots will block the use of other slots. [Table 3-8](#) shows which slots become unusable for other electrical cards when the DS3/EC1-48 card is installed in a particular slot.

Table 3-8 DS3/EC1-48 Slot Restrictions

Slot	Additional Unusable Slots for Electrical Cards
1	5 and 6
2	3 or 4 (except another DS3/EC1-48 card can be installed in Slot 3)
3	—
15	—
16	14 and 15 (except another DS3/EC1-48 card can be installed in Slot 15)
17	12 and 13



Caution

Do not install low-density DS-1 cards in the same side of the shelf as DS3/EC1-48 cards.

**Caution**

Do not install a DS3/EC1-48 card in Slots 1 or 2 if you have installed an MXP_2.5G_10G card in Slot 3. Likewise, do not install a DS3/EC1-48 card in Slots 16 or 17 if you have installed an MXP_2.5G_10G card in Slot 15. If you do, the cards will interact and cause DS-3 bit errors.

With the proper backplane EIA, the card supports BNC or SCSI (UBIC) connectors. See the [“7.2 Electrical Card Protection and the Backplane”](#) section on page 7-5 for more information about electrical card slot protection and restrictions.

3.6.2 DS3/EC1-48 Faceplate and Block Diagram

[Figure 3-7](#) shows the DS3/EC1-48 faceplate and a block diagram of the card.

Figure 3-7 DS3/EC1-48 Faceplate and Block Diagram

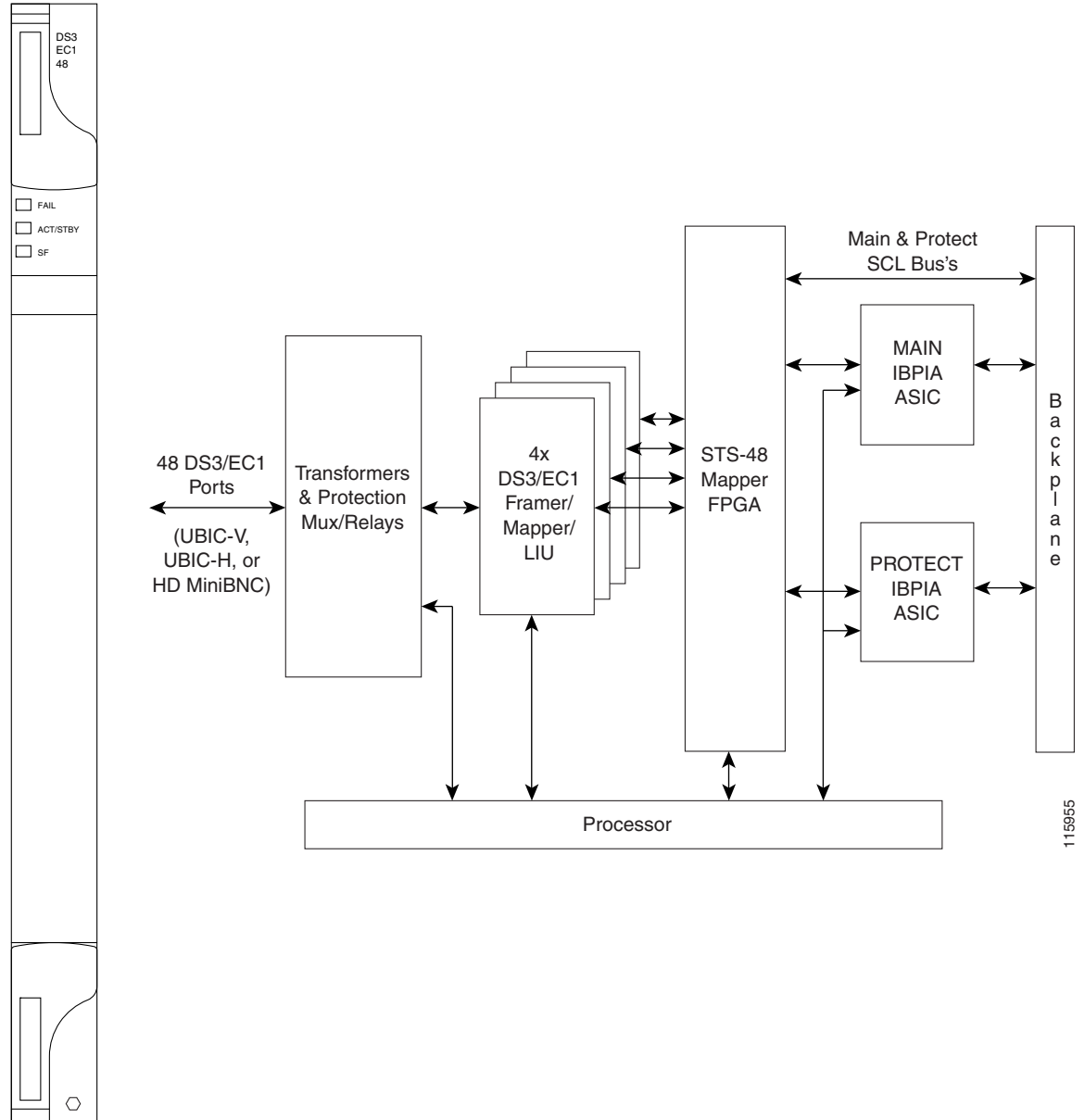

115955

3.6.3 DS3/EC1-48 Card-Level Indicators

The DS3/EC1-48 card has three card-level LED indicators ([Table 3-9](#)).

Table 3-9 DS3/EC1-48 Card-Level Indicators

Card-Level Indicators	Description
Red FAIL LED	Indicates that the card processor is not ready. This LED is on during reset. The FAIL LED flashes during the boot process. Replace the card if the red FAIL LED persists in flashing.
ACT/STBY LED Green (Active) Amber (Standby)	When the ACT/STBY LED is green, the card is operational and ready to carry traffic. When the ACT/STBY LED is amber, the card is operational and in standby (protect) mode.
Amber SF LED	Indicates a signal failure or condition such as LOS or LOF on one or more card ports.

3.6.4 DS3/EC1-48 Port-Level Indicators

You can obtain the status of the DS3/EC1-48 card ports by using the LCD screen on the ONS 15454 fan-tray assembly. Use the LCD to view the status of any port or card slot; the screen displays the number and severity of alarms for a given port or slot.

3.7 DS3i-N-12 Card



Note

For hardware specifications, see the [“A.5.6 DS3i-N-12 Card Specifications”](#) section on page A-21.

The 12-port ONS 15454 DS3i-N-12 card provides 12 ITU-T G.703, ITU-T G.704, and Telcordia GR-499-CORE compliant DS-3 ports per card. Each port operates at 44.736 Mbps over a 75-ohm coaxial cable. The DS3i-N-12 card supports 1:1 or 1:N protection with the proper backplane EIA. The DS3i-N-12 card works with the XCVT, XC10G, and XC-VXC-10G cross-connect cards. Four sets of three adjacent DS-3 signals (Port 1 through Port 3, Port 4 through Port 6, Port 7 through Port 9, and Port 10 through Port 12) are mapped to VC3s into a VC4 and transported as an STC-3c.

The DS3i-N-12 can also aggregate DS3 and E1 traffic and transport it between SONET and SDH networks through AU4/STS 3 trunks, with the ability to add and drop DS3s to an STS3 trunk at intermediate nodes.

3.7.1 DS3i-N-12 Slots and Connectors

You can install the DS3i-N-12 card in Slots 1 to 6 and 12 to 17. The DS3i-N-12 can operate as the protect card in a 1:N (N <= 5) DS-3 protection group on a half-shelf basis, with protection cards in Slots 3 and 15. It has circuitry that allows it to protect up to five working DS3i-N-12 cards. With the proper backplane EIA, the card supports BNC or SMB connectors. See the [“7.2 Electrical Card Protection and the Backplane”](#) section on page 7-5 for more information about electrical card slot protection and restrictions.

[Figure 3-8](#) shows the DS3i-N-12 faceplate and block diagram.

Figure 3-8 DS3i-N-12 Faceplate and Block Diagram

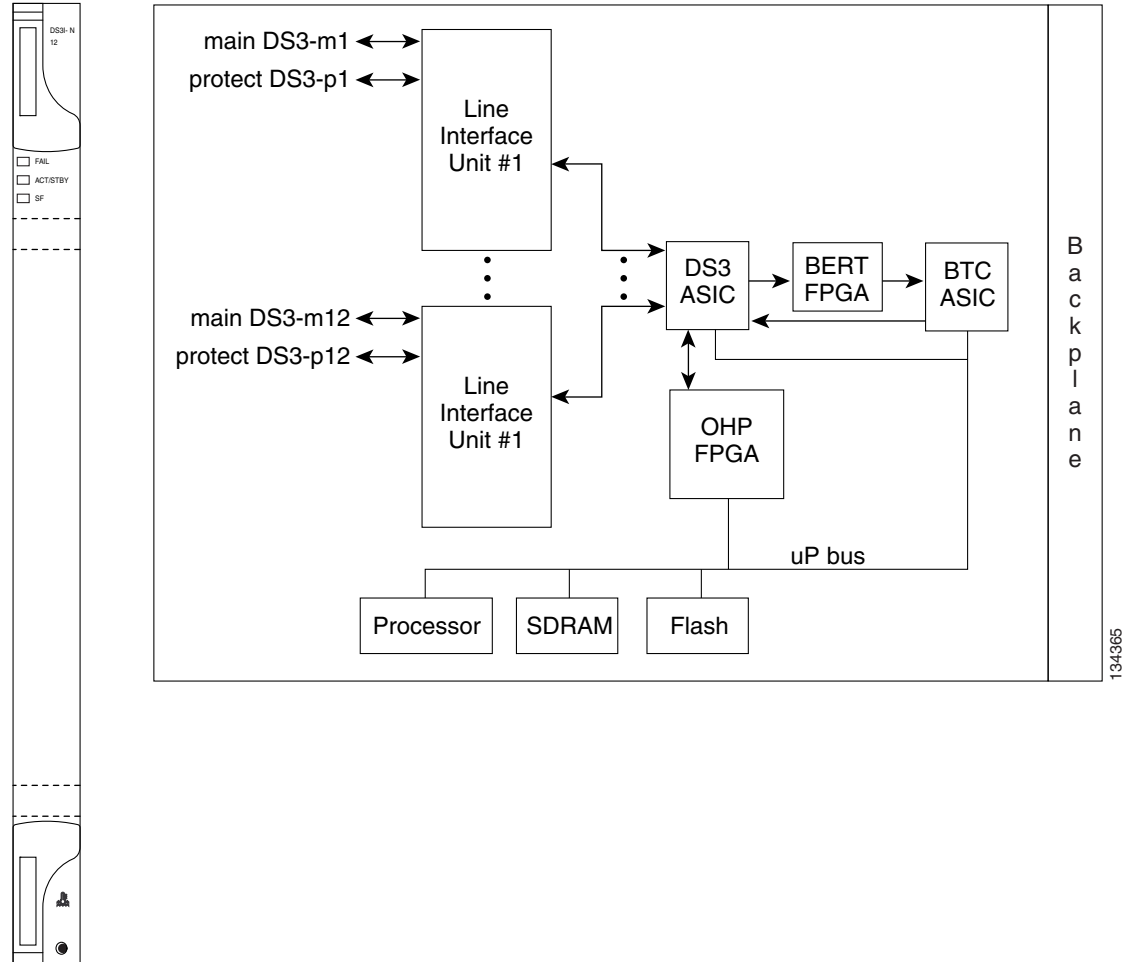

The following list summarizes the DS3i-N-12 card features:

- Provisionable framing format (M23, C-bit, or unframed)
- Autorecognition and provisioning of incoming framing
- VC-3 payload mapping as per ITU-T G.707, mapped into VC-4 and transported as STS-3c
- Idle signal (“1100”) monitoring as per Telcordia GR-499-CORE
- P-bit monitoring
- C-bit parity monitoring
- X-bit monitoring
- M-bit monitoring
- F-bit monitoring
- Far-end block error (FEBE) monitoring
- Far-end alarm and control (FEAC) status and loop code detection
- Path trace byte support with TIM-P alarm generation

3.7.2 DS3i-N-12 Card-Level Indicators

Table 3-10 describes the three LEDs on the DS3i-N-12 card faceplate.

Table 3-10 DS3i-N-12 Card-Level Indicators

Card-Level LEDs	Description
Red FAIL LED	Indicates that the card processor is not ready. This LED is on during reset. The FAIL LED flashes during the boot process. Replace the card if the red FAIL LED persists in flashing.
ACT/STBY LED Green (Active) Amber (Standby)	When the ACT/STBY LED is green, the DS3i-N-12 card is operational and ready to carry traffic. When the ACT/STBY LED is amber, the DS3i-N-12 card is operational and in standby (protect) mode.
Amber SF LED	Indicates a signal failure or condition such as LOS or LOF on one or more card ports.

3.7.3 DS3i-N-12 Port-Level Indicators

You can find the status of the DS3i-N-12 card ports by using the LCD screen on the ONS 15454 fan-tray assembly. Use the LCD to view the status of any port or card slot; the screen displays the number and severity of alarms for a given port or slot. Refer to the *Cisco ONS 15454 Troubleshooting Guide* for a complete description of the alarm messages.

3.8 DS3-12E and DS3N-12E Cards



Note

For hardware specifications, see the [“A.5.7 DS3-12E and DS3N-12E Card Specifications”](#) section on page A-22.

The ONS 15454 DS3-12E card provides 12 Telcordia-compliant GR-499 DS-3 ports per card. Each port operates at 44.736 Mbps over a single 75-ohm 728A or equivalent coaxial span. The DS3-12E card provides enhanced performance monitoring functions. The DS3-12E can detect several different errored logic bits within a DS3 frame. This function allows the ONS 15454 to identify a degrading DS3 facility caused by upstream electronics (DS3 Framer). In addition, DS3 frame format autodetection and J1 path trace are supported. By monitoring additional overhead in the DS3 frame, subtle network degradations can be detected.

The following list summarizes DS3-12E card features:

- Provisionable framing format M23, C-bit or unframed
- Autorecognition and provisioning of incoming framing
- P-bit monitoring
- C-bit parity monitoring
- X-bit monitoring
- M-bit monitoring
- F-bit monitoring

- FEBE monitoring
- FEAC status and loop code detection
- Path trace byte support with TIM-P alarm generation

The DS3-12E supports a 1:1 protection scheme, meaning it can operate as the protect card for one other DS3-12E card.

The DS3N-12E can operate as the protect card in a 1:N ($N \leq 5$) DS3 protection group. It has additional circuitry not present on the basic DS3-12E card that allows it to protect up to five working DS3-12E cards. The basic DS3-12E card can only function as the protect card for one other DS3-12E card.

3.8.1 DS3-12E and DS3N-12E Slots and Connectors

You can install the DS3-12E and DS3N-12E cards in Slots 1 to 6 or 12 to 17 on the ONS 15454. Each DS3-12E and DS3N-12E port features DSX-level outputs supporting distances up to 137 meters (450 feet). With the proper backplane EIA, the card supports BNC or SMB connectors. See the [“7.2 Electrical Card Protection and the Backplane”](#) section on page 7-5 for more information about electrical card slot protection and restrictions.

3.8.2 DS3-12E Faceplate and Block Diagram

[Figure 3-9](#) shows the DS3-12E faceplate and a block diagram of the card.

Figure 3-9 DS3-12E Faceplate and Block Diagram

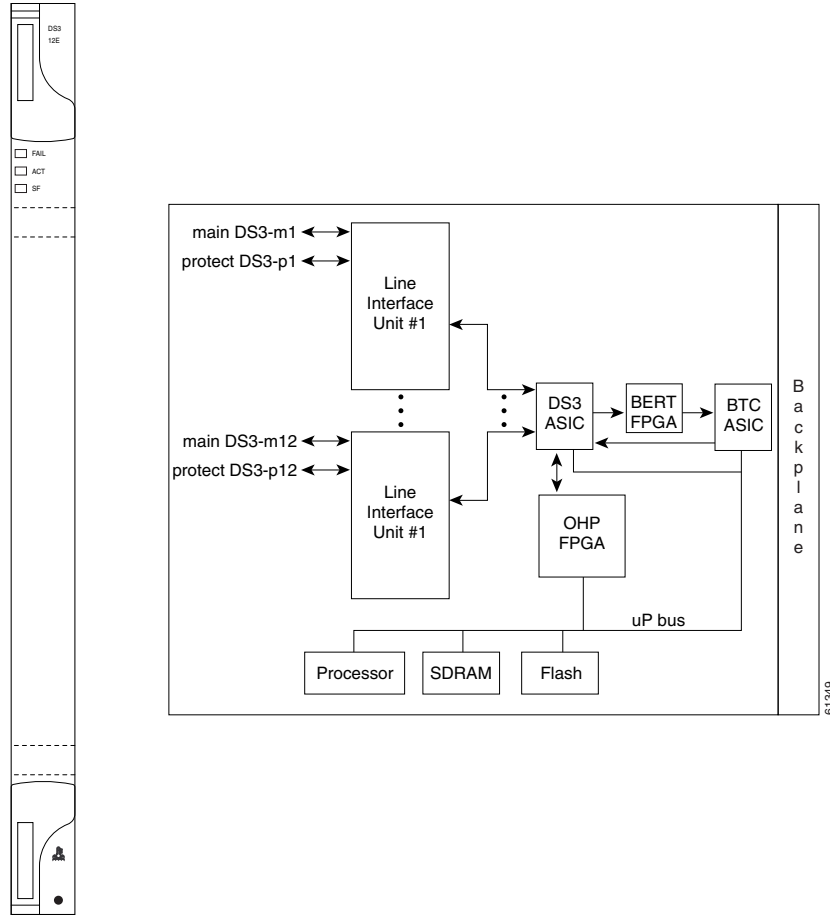
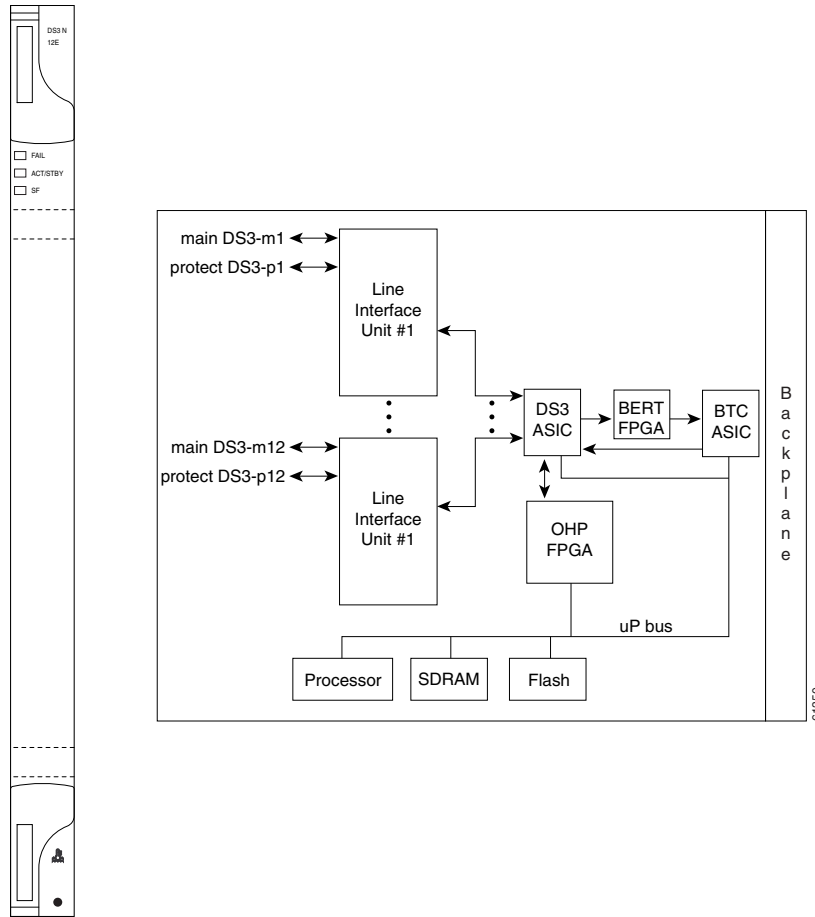

Figure 3-10 shows the DS3N-12E faceplate and a block diagram of the card.

Figure 3-10 DS3N-12E Faceplate and Block Diagram



3.8.3 DS3-12E and DS3N-12E Card-Level Indicators

Table 3-11 describes the three card-level LEDs on the DS3-12E and DS3N-12E card faceplates.

Table 3-11 DS3-12E and DS3N-12E Card-Level Indicators

Card-Level Indicators	Description
Red FAIL LED	The red FAIL LED indicates that the card processor is not ready. Replace the card if the red FAIL LED persists.
ACT/STBY LED Green (Active) Amber (Standby)	When the ACT/STBY LED is green, the card is operational and ready to carry traffic. When the ACT/STBY LED is amber, the card is operational and in standby (protect) mode.
Amber SF LED	The amber SF LED indicates a signal failure or condition such as port LOS or AIS.

3.8.4 DS3-12E and DS3N-12E Port-Level Indicators

You can find the status of the DS3-12E and DS3N-12E card ports by using the LCD screen on the ONS 15454 fan-tray assembly. Use the LCD to quickly view the status of any port or card slot; the screen displays the number and severity of alarms for a given port or slot.

3.9 DS3XM-6 Card

**Note**

For hardware specifications, see the [“A.5.9 DS3XM-6 Card Specifications”](#) section on page A-24.

The DS3XM-6 card, commonly referred to as a transmux card, provides six Telcordia-compliant, GR-499-CORE M13 multiplexing ports. The DS3XM-6 converts six framed DS-3 network connections to 28 x6 or 168 VT1.5s. DS3XM-6 cards operate at the VT1.5 level.

3.9.1 DS3XM-6 Slots and Connectors

The DS3XM-6 card supports 1:1 protection with the proper backplane EIA. EIAs are available with BNC or SMB connectors.

You can install the DS3XM-6 in Slots 1 to 6 or 12 to 17. Each DS3XM-6 port features DSX-level outputs supporting distances up to 137 meters (450 feet) depending on facility conditions. See [“7.2 Electrical Card Protection and the Backplane”](#) section on page 7-5 for more information about electrical card slot protection and restrictions.

3.9.2 DS3XM-6 Faceplate and Block Diagram

[Figure 3-11](#) shows the DS3XM-6 faceplate and a block diagram of the card.

Figure 3-11 DS3XM-6 Faceplate and Block Diagram

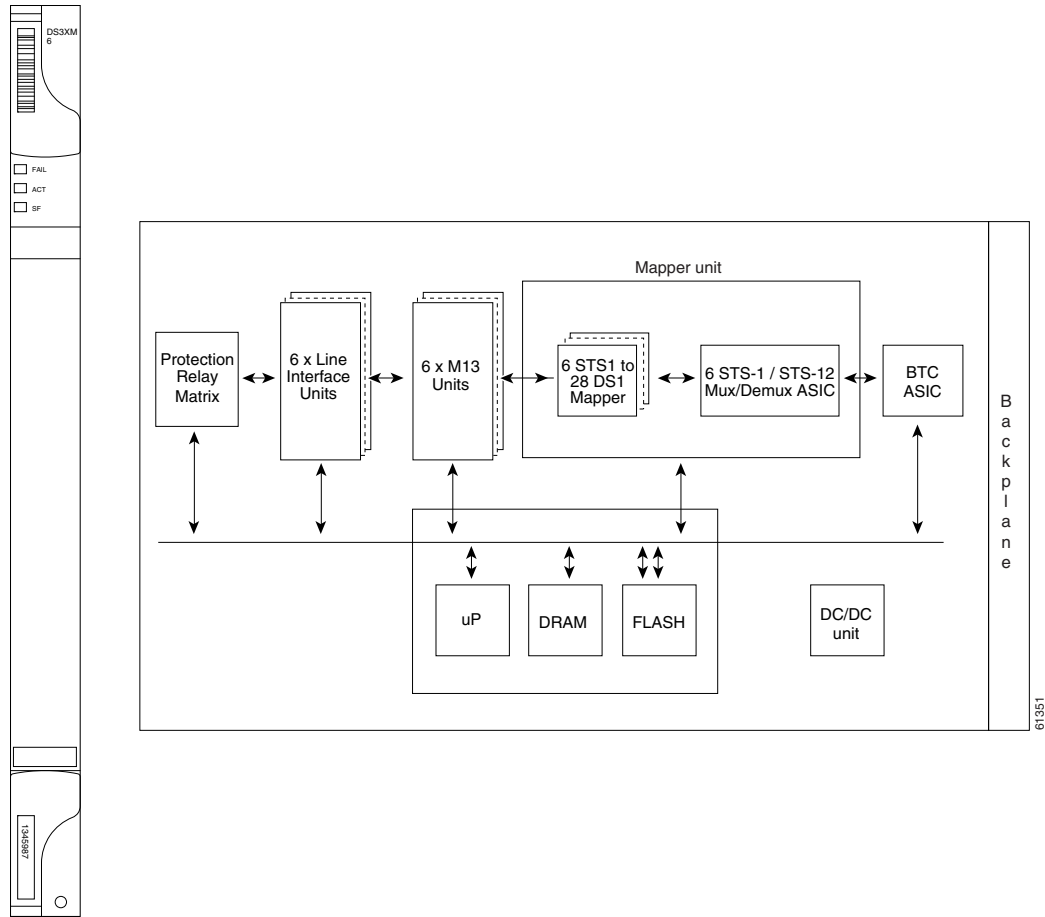

3.9.3 DS3XM-6 Hosted By XCVT

The DS3XM-6 card works in conjunction with the XCVT card. A single DS3XM-6 can demultiplex six DS-3 signals into 168 VT1.5s that the XCVT card then manages and cross connects. XCVT cards host a maximum of 336 bidirectional VT1.5s on two DS3XM-6 cards. In most network configurations, two DS3XM-6 cards are paired together as working and protect cards.

3.9.4 DS3XM-6 Card-Level Indicators

Table 3-12 describes the three card-level LEDs on the DS3XM-6 card faceplate.

Table 3-12 DS3XM-6 Card-Level Indicators

Card-Level Indicators	Description
Red FAIL LED	The red FAIL LED indicates that the card processor is not ready. Replace the card if the red FAIL LED persists.
ACT/STBY LED Green (Active) Amber (Standby)	When the ACT/STBY LED is green, the DS3XM-6 card is operational and ready to carry traffic. When the ACT/STBY LED is amber, the DS3XM-6 card is operational and in standby in a 1:1 protection group.
Amber SF LED	The amber SF LED indicates a signal failure or condition such as LOS, LOF, or high BER on one or more card ports.

3.9.5 DS3XM-6 Port-Level Indicators

You can find the status of the six DS3XM-6 card ports by using the LCD screen on the ONS 15454 fan-tray assembly. Use the LCD to quickly view the status of any port or card slot; the screen displays the number and severity of alarms for a given port or slot.

3.10 DS3XM-12 Card



Note

For hardware specifications, see the [“A.5.8 DS3XM-12 Card Specifications” section on page A-23](#).

The DS3XM-12 card, commonly referred to as a transmux card, provides twelve Telcordia-compliant, GR-499-CORE M13 multiplexing ports. The DS3XM-12 converts up to 12 framed DS-3 network connections to 12 x 28 VT1.5s.

3.10.1 Backplane Configurations

The DS3XM-12 card has 12 framed DS-3 physical ports (known as “ported” mode). The card also supports a maximum of 12 “portless” DS3-mapped STS1 interfaces depending on the type of cross-connect used. Each physical port corresponds to two portless ports. If a circuit is provisioned to a physical port, its associated portless pair becomes unavailable and vice versa. See the [“11.4 Portless Transmux” section on page 11-15](#) for more information.

The DS3XM-12 card is compatible with the XCVT, XC10G, and XC-VXC-10G cross-connect cards.



Note

The DS3XM-12 card supports an errorless software-initiated cross-connect card switch when used in a shelf equipped with XC-VXC-10G and TCC2/TCC2P cards.



Caution

During an upgrade of the DS3XM-6 card to DS3XM-12 card, the DS-3XM-12 card (in slots 1 to 5) encounters an insufficient cable loss of margin when the LBO setting on the DS-3 input ports are set between 225 to 450 feet cable lengths.

The DS3XM-12 supports three different backplane throughput configurations:

- STS-48 when an XC10G or XC-VXC-10G card is used. This configuration supports the OC-48 rate in any slot.
- STS-48 for the Slots 5, 6, 12, and 13 when an XCVT card is used.
- STS-12 for Slot 1 through 4, and 7 through 12 slots when an XCVT card is used. This configuration is bandwidth-limiting in the portless mode of operation.

The backplane throughput configuration is selected in CTC card view using the Maintenance > Card tab.

3.10.2 Ported Mode

The “ported” mode supports up to 12 framed DS-3 bidirectional mapped signals to each DS3XM-12 card, where the traffic is demultiplexed and mapped into a VT1.5 payload. This payload is then mapped and multiplexed up to a bidirectional STS-1.

3.10.3 Portless Mode

The “portless” mode allows for IXC hand off connections through a standard SONET fiber optical interface with DS-3-mapped STS-1s as a payload. This physical connection is accomplished with any of the OC-N cards. The system cross-connect grooms the DS-3 mapped STS1 traffic to the appropriate DS3XM-12 card, where the traffic is demultiplexed and mapped into a VT1.5 payload. This payload is then mapped and multiplexed up to a higher rate STS-1. See the “[11.4 Portless Transmux](#)” section on [page 11-15](#) for more information.

3.10.4 Shelf Configurations

The DS3XM-12 card supports the XCVT, XC10G, and XC-VXC-10G cards. The DS3XM-12 card is supported in any of the multiservice slots (Slots 1 through 6 and 12 through 17).

The DS3XM-12 card operates at the VT1.5 level and supports a maximum of 6 or 12 ports of “portless” (DS-3-mapped STS1s) interface, depending on the shelf configuration (see [Table 3-13](#)).

Table 3-13 DS3XM-12 Shelf Configurations

Port Maximums	Slots 1 through 4, and 14 through 17 (XCVT Card)	Slots 5, 6, 12, and 13 (XCVT, XC10G, or XC-VXC-10G Cards)	XC10G/XC-VXC-10G Shelf (any multiservice slot)
Portless Ports	6	12	12
Ported Ports	12	12	12



Caution

Do not install low-density DS-1 cards in the same side of the shelf as DS3XM-12 cards.

3.10.5 Protection Modes

The DS3XM-12 card supports 1:1 and 1:N protection groups, where $N \leq 5$. However, $N \leq 7$ if one of the following conditions is true:

- Only portless connections are used.
- A combination of ported and portless connections is used but all the ported cards being protected are on the same side of the chassis as the protecting card.

These protection groups can be implemented in the ONS 15454 SONET platform for both the A and B sides and do not require a special protect card.

In 1:N protection, the protect card must be in Slot 3 or 15. In 1:1 protection, the working and protect cards must be in adjacent slots. The protection switches cause a traffic hit of no more than 50 ms. See the “[7.2 Electrical Card Protection and the Backplane](#)” section on page 7-5 for more information about electrical card slot protection and restrictions.

3.10.6 Card Features

Table 3-14 summarizes the DS3XM-12 features.

Table 3-14 DS3XM-12 Features

Feature	Description
Protection	1:1 and 1:N protection (“ported” and “portless”)
Upgrade	<ul style="list-style-type: none"> • Errorless software upgrade • In-service upgrade of legacy DS3XM-6 to DS3XM-12 (> 60 ms hit)
Performance Monitoring	<ul style="list-style-type: none"> • DS-3 M2-3 near-end performance monitoring (PM) parameters • DS-3 C-bit near end and far end PM parameters • DS-1 near end PM parameters • DS-1 Extended Super Frame (ESF) PM far end parameters based on FDL PRM messages • 1989 AT&T TR 54016 DS1 ESF PM • SPRM and NPRM DS1 PM parameters
Loopbacks	<ul style="list-style-type: none"> • DS3 terminal and facility • DS1 facility • DS1 terminal • FEAC based DS1 and DS3 loopbacks (TX and RX) • DS1 ESF-FDL TX line and payload loopbacks • DS1 SF (D4) “in-band” TX loopbacks • AT&T TR 54016 ESF DS1 TX line and payload loopbacks
DS1 Auto-Frame Detection	DS1 frame autodetection and autoprovisioning
Manual DS1 frame provisioning	Works in conjunction with the DS1 autoprovisioning and gives you override capability

Table 3-14 DS3XM-12 Features

Feature	Description
Manual DS3 frame provisioning	Legacy feature (C-Bit and M23 frame formats are supported)
J1	Legacy feature (extended to 6 additional ports)
J2	336 J2 strings are supported
Portless	Supports DS3 data from the backplane in addition to the DS3 data from the line interface unit
Diagnostics	Power-up diagnostics on working and protect cards

3.10.7 DS3XM-12 Slots and Connectors

The DS3XM-12 card can be used with BNC, SMB, SCSI (UBIC), or MiniBNC EIA connectors.

The card can be installed in Slots 1 to 6 or 12 to 17. Each DS3XM-12 port features DSX-level outputs supporting distances up to 137 meters (450 feet) depending on facility conditions.

3.10.8 DS3XM-12 Faceplate and Block Diagram

[Figure 3-12](#) shows the DS3XM-12 faceplate and a block diagram of the card.

Figure 3-12 DS3XM-12 Faceplate and Block Diagram

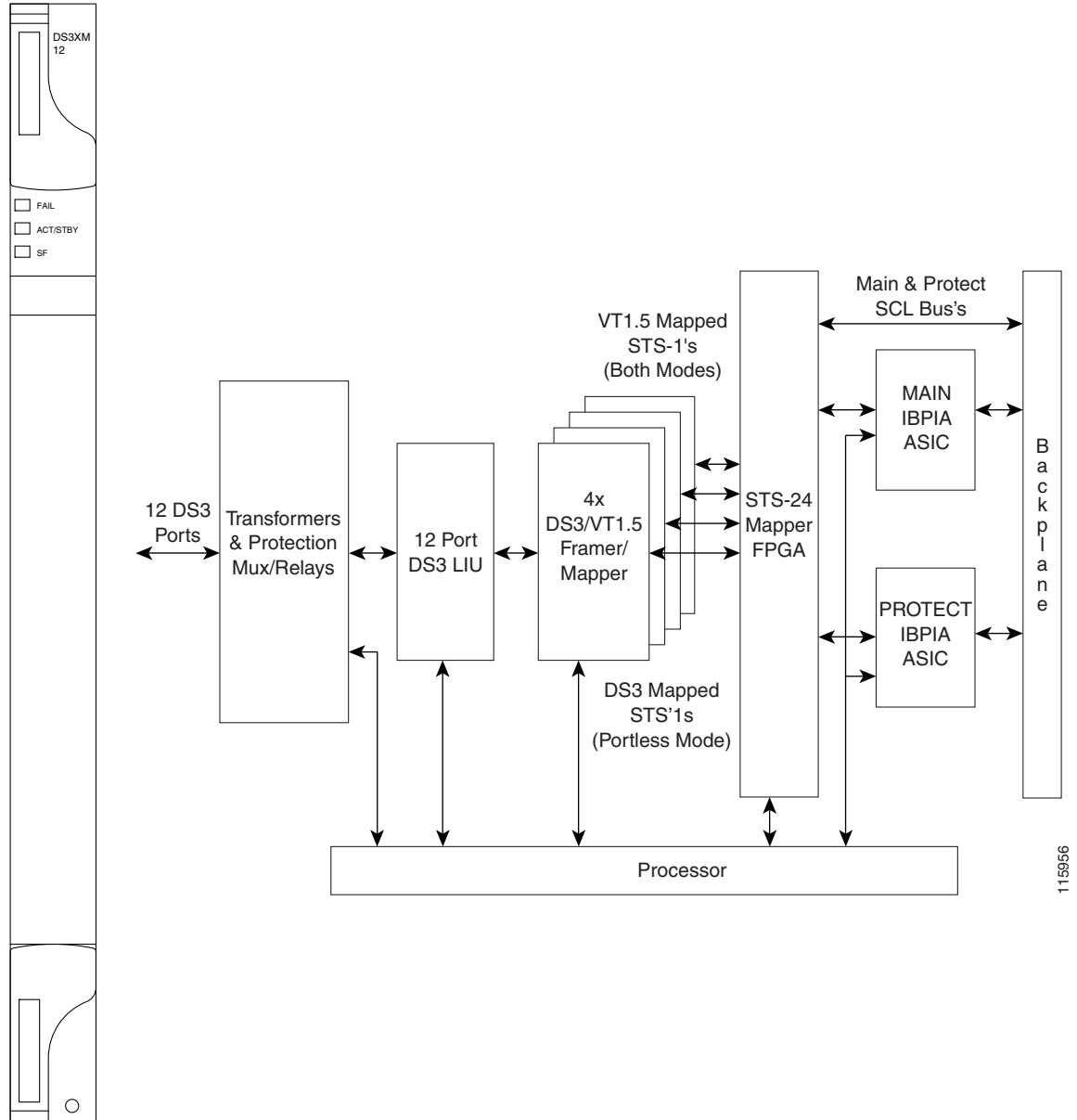

3.10.9 DS3XM-12 Card-Level Indicators

Table 3-15 describes the three card-level LEDs on the DS3XM-12 card faceplate.

Table 3-15 DS3XM-12 Card-Level Indicators

Card-Level Indicators	Description
Red FAIL LED	The red FAIL LED indicates that the card processor is not ready. It is steady while the self-test runs, and blinks during provisioning. Replace the card if the red FAIL LED persists.
ACT/STBY LED Green (Active) Amber (Standby)	When the ACT/STBY LED is green, the DS3XM-12 card is operational and ready to carry traffic. When the ACT/STBY LED is amber, the DS3XM-12 card is operational and in standby in a 1:1 protection group.
Amber SF LED	The amber SF LED indicates a signal failure or condition such as LOS, LOF, or high BER on one or more card ports.

3.10.10 DS3XM-12 Port-Level Indicators

You can find the status of the twelve DS3XM-12 card ports by using the LCD screen on the ONS 15454 fan-tray assembly. Use the LCD to quickly view the status of any port or card slot; the screen displays the number and severity of alarms for a given port or slot.



CHAPTER 4

Optical Cards



Note

The terms "Unidirectional Path Switched Ring" and "UPSR" may appear in Cisco literature. These terms do not refer to using Cisco ONS 15xxx products in a unidirectional path switched ring configuration. Rather, these terms, as well as "Path Protected Mesh Network" and "PPMN," refer generally to Cisco's path protection feature, which may be used in any topological network configuration. Cisco does not recommend using its path protection feature in any particular topological network configuration.

This chapter describes the Cisco ONS 15454 optical card features and functions. It includes descriptions, hardware specifications, and block diagrams for each optical card. For installation and card turn-up procedures, refer to the *Cisco ONS 15454 Procedure Guide*.

Chapter topics include:

- [4.1 Optical Card Overview, page 4-2](#)
- [4.2 OC3 IR 4/STM1 SH 1310 Card, page 4-5](#)
- [4.3 OC3 IR/STM1 SH 1310-8 Card, page 4-7](#)
- [4.4 OC12 IR/STM4 SH 1310 Card, page 4-9](#)
- [4.5 OC12 LR/STM4 LH 1310 Card, page 4-11](#)
- [4.6 OC12 LR/STM4 LH 1550 Card, page 4-13](#)
- [4.7 OC12 IR/STM4 SH 1310-4 Card, page 4-15](#)
- [4.8 OC48 IR 1310 Card, page 4-17](#)
- [4.9 OC48 LR 1550 Card, page 4-19](#)
- [4.10 OC48 IR/STM16 SH AS 1310 Card, page 4-21](#)
- [4.11 OC48 LR/STM16 LH AS 1550 Card, page 4-23](#)
- [4.12 OC48 ELR/STM16 EH 100 GHz Cards, page 4-25](#)
- [4.13 OC48 ELR 200 GHz Cards, page 4-27](#)
- [4.14 OC192 SR/STM64 IO 1310 Card, page 4-29](#)
- [4.15 OC192 IR/STM64 SH 1550 Card, page 4-31](#)
- [4.16 OC192 LR/STM64 LH 1550 Card, page 4-33](#)
- [4.17 OC192 LR/STM64 LH ITU 15xx.xx Card, page 4-38](#)
- [4.18 15454_MRC-12 Multirate Card, page 4-41](#)
- [4.19 OC192SR1/STM64IO Short Reach and OC192/STM64 Any Reach Cards, page 4-46](#)

- [4.20 Optical Card SFPs and XFPs, page 4-49](#)

4.1 Optical Card Overview

Each card is marked with a symbol that corresponds to a slot (or slots) on the ONS 15454 shelf assembly. The cards are then installed into slots displaying the same symbols. See the “[1.17 Cards and Slots](#)” section on [page 1-68](#) for a list of slots and symbols.

4.1.1 Card Summary

[Table 4-1](#) lists the Cisco ONS 15454 optical cards.

Table 4-1 *Optical Cards for the ONS 15454*

Card	Port Description	For Additional Information...
OC3 IR 4 SH 1310	The OC3 IR 4 SH 1310 card provides four intermediate- or short-range OC-3 ports and operates at 1310 nm. Note The OC3 IR 4 SH 1310 and OC3 IR 4/STM1 SH 1310 cards are functionally the same.	See the “ 4.2 OC3 IR 4/STM1 SH 1310 Card ” section on page 4-5 .
OC3 IR 4/ STM1 SH 1310	The OC3 IR 4/STM1 SH 1310 card provides four intermediate- or short-range OC-3 ports and operates at 1310 nm.	See the “ 4.2 OC3 IR 4/STM1 SH 1310 Card ” section on page 4-5 .
OC3 IR/ STM1 SH 1310-8	The OC3 IR/STM1 SH 1310-8 card provides eight intermediate- or short-range OC-3 ports and operates at 1310 nm.	See the “ 4.3 OC3 IR/STM1 SH 1310-8 Card ” section on page 4-7 .
OC12 IR 1310	The OC12 IR 1310 card provides one intermediate- or short-range OC-12 port and operates at 1310 nm. Note The OC12 IR 1310 and OC12/STM4 SH 1310 cards are functionally the same.	See the “ 4.4 OC12 IR/STM4 SH 1310 Card ” section on page 4-9 .
OC12 IR/STM4 SH 1310	The OC12 IR/STM4 SH 1310 card provides one intermediate- or short-range OC-12 port and operates at 1310 nm.	See the “ 4.4 OC12 IR/STM4 SH 1310 Card ” section on page 4-9 .
OC12 LR 1310	The OC12 LR 1310 card provides one long-range OC-12 port and operates at 1310 nm. Note The OC12 LR 1310 and OC12 LR/STM4 LH 1310 cards are functionally the same.	See the “ 4.5 OC12 LR/STM4 LH 1310 Card ” section on page 4-11 .
OC12 LR/STM4 LH 1310	The OC12 LR/STM4 LH 1310 card provides one long-range OC-12 port and operates at 1310 nm.	See the “ 4.5 OC12 LR/STM4 LH 1310 Card ” section on page 4-11 .
OC12 LR 1550	The OC12 LR 1550 card provides one long-range OC-12 port and operates at 1550 nm. Note The OC12 LR 1550 and OC12 LR/STM4 LH 1550 cards are functionally the same.	See the “ 4.6 OC12 LR/STM4 LH 1550 Card ” section on page 4-13 .

Table 4-1 Optical Cards for the ONS 15454 (continued)

Card	Port Description	For Additional Information...
OC12 LR/STM4 LH 1550	The OC12 LR/STM4 LH 1550 card provides one long-range OC-12 port and operates at 1550 nm.	See the “ 4.6 OC12 LR/STM4 LH 1550 Card ” section on page 4-13.
OC12 IR/STM4 SH 1310-4	The OC12 IR/STM4 SH 1310-4 card provides four intermediate- or short-range OC-12 ports and operates at 1310 nm.	See the “ 4.7 OC12 IR/STM4 SH 1310-4 Card ” section on page 4-15.
OC48 IR 1310	The OC48 IR 1310 card provides one intermediate-range OC-48 port and operates at 1310 nm.	See the “ 4.8 OC48 IR 1310 Card ” section on page 4-17.
OC48 LR 1550	The OC48 LR 1550 card provides one long-range OC-48 port and operates at 1550 nm.	See the “ 4.9 OC48 LR 1550 Card ” section on page 4-19.
OC48 IR/STM16 SH AS 1310	The OC48 IR/STM16 SH AS 1310 card provides one intermediate- or short-range OC-48 port at 1310 nm.	See the “ 4.10 OC48 IR/STM16 SH AS 1310 Card ” section on page 4-21.
OC48 LR/STM16 LH AS 1550	The OC48 LR/STM16 LH AS 1550 card provides one long-range OC-48 port at 1550 nm.	See the “ 4.11 OC48 LR/STM16 LH AS 1550 Card ” section on page 4-23.
OC48 ELR/STM16 EH 100 GHz	The OC48 ELR/STM16 EH 100 GHz card provides one long-range (enhanced) OC-48 port and operates in Slot 5, 6, 12, or 13. This card is available in 18 different wavelengths (9 in the blue band and 9 in the red band) in the 1550-nm range, every second wavelength in the ITU grid for 100-GHz spacing dense wavelength division multiplexing (DWDM).	See the “ 4.12 OC48 ELR/STM16 EH 100 GHz Cards ” section on page 4-25.
OC48 ELR 200 GHz	The OC48 ELR 200 GHz card provides one long-range (enhanced) OC-48 port and operates in Slot 5, 6, 12, or 13. This card is available in 18 different wavelengths (9 in the blue band and 9 in the red band) in the 1550-nm range, every fourth wavelength in the ITU grid for 200-GHz spacing DWDM.	See the “ 4.13 OC48 ELR 200 GHz Cards ” section on page 4-27.
OC192 SR/STM64 IO 1310	The OC192 SR/STM64 IO 1310 card provides one intra-office-haul OC-192 port at 1310 nm.	See the “ 4.14 OC192 SR/STM64 IO 1310 Card ” section on page 4-29.
OC192 IR/STM64 SH 1550	The OC192 IR/STM64 SH 1550 card provides one intermediate-range OC-192 port at 1550 nm.	See the “ 4.15 OC192 IR/STM64 SH 1550 Card ” section on page 4-31.
OC192 LR/STM64 LH 1550	The OC192 LR/STM64 LH 1550 card provides one long-range OC-192 port at 1550 nm.	See the “ 4.16 OC192 LR/STM64 LH 1550 Card ” section on page 4-33.
OC192 LR/STM64 LH ITU 15xx.xx	The OC192 LR/STM64 LH ITU 15xx.xx card provides one extended long-range OC-192 port. This card is available in multiple wavelengths in the 1550-nm range of the ITU grid for 100-GHz-spaced DWDM.	See the “ 4.17 OC192 LR/STM64 LH ITU 15xx.xx Card ” section on page 4-38.

Table 4-1 Optical Cards for the ONS 15454 (continued)

Card	Port Description	For Additional Information...
15454_MRC-12	The 15454_MRC-12 card provides up to twelve OC-3 or OC-12 ports, or up to four STM-16 ports, using dense wave division multiplexing (DWDM) SFPs. The card operates in Slots 1 to 6 and 12 to 17.	See the “4.18 15454_MRC-12 Multirate Card” section on page 4-41.
OC192SR1/STM64 IO Short Reach and OC192/STM64 Any Reach¹	The OC192SR1/STM64 IO Short Reach and OC192/STM64 Any Reach cards each provide a single OC-192/STM-64 interface capable of operating with SR-1, IR-2, and LR-2 XFP modules (depending on the card) at 1310 nm and 1550 nm. The cards operate in Slot 5, 6, 12, or 13 with the XC10G and XC-VXC-10G cards.	See the “4.19 OC192SR1/STM64 IO Short Reach and OC192/STM64 Any Reach Cards” section on page 4-46.

1. In the Cisco Transport Controller (CTC) GUI, these cards are known as OC192-XFP.

**Note**

The Cisco OC3 IR/STM1 SH, OC12 IR/STM4 SH, and OC48 IR/STM16 SH interface optics, all working at 1310 nm, are optimized for the most widely used SMF-28 fiber, available from many suppliers.

Corning MetroCor fiber is optimized for optical interfaces that transmit at 1550 nm or in the C and L DWDM windows, and targets interfaces with higher dispersion tolerances than those found in OC3 IR/STM1 SH, OC12 IR/STM4 SH, and OC48 IR/STM16 SH interface optics. If you are using Corning MetroCor fiber, OC3 IR/STM1 SH, OC12 IR/STM4 SH, and OC48 IR/STM16 SH interface optics become dispersion limited before they become attenuation limited. In this case, consider using OC12 LR/STM4 LH and OC48 LR/STM16 LH cards instead of OC12 IR/STM4 SH and OC48 IR/STM16 SH cards.

With all fiber types, network planners/engineers should review the relative fiber type and optics specifications to determine attenuation, dispersion, and other characteristics to ensure appropriate deployment.

4.1.2 Card Compatibility

[Table 4-2](#) lists the CTC software compatibility for each optical card. See [Table 2-5 on page 2-4](#) for a list of cross-connect cards that are compatible with each optical card.

**Note**

“Yes” indicates that this card is fully or partially supported by the indicated software release. Refer to the individual card reference section for more information about software limitations for this card.

Table 4-2 Optical Card Software Release Compatibility

Optical Card	R2.2.1	R2.2.2	R3.0.1	R3.1	R3.2	R3.3	R3.4	R4.0	R4.1	R4.5 ¹	R4.6	R4.7 ¹	R5.0	R6.0	R7.0
OC3 IR 4 1310	Yes	Yes	Yes	Yes	Yes	Yes	Yes	Yes	Yes	—	Yes	—	Yes	Yes	Yes
OC3 IR 4/STM1 SH 1310	Yes	Yes	Yes	Yes	Yes	Yes	Yes	Yes	Yes	—	Yes	—	Yes	Yes	Yes

Table 4-2 Optical Card Software Release Compatibility (continued)

Optical Card	R2.2.1	R2.2.2	R3.0.1	R3.1	R3.2	R3.3	R3.4	R4.0	R4.1	R4.5 ¹	R4.6	R4.7 ¹	R5.0	R6.0	R7.0
OC3 IR/STM1 SH 1310-8	—	—	—	—	—	—	—	Yes	Yes	—	Yes	—	Yes	Yes	Yes
OC12 IR/STM4 SH 1310	Yes	Yes	Yes	Yes	Yes	Yes	Yes	Yes	Yes	—	Yes	—	Yes	Yes	Yes
OC12 IR 1310	Yes	Yes	Yes	Yes	Yes	Yes	Yes	Yes	Yes	—	Yes	—	Yes	Yes	Yes
OC12 LR 1310	Yes	Yes	Yes	Yes	Yes	Yes	Yes	Yes	Yes	—	Yes	—	Yes	Yes	Yes
OC12 LR 1550	Yes	Yes	Yes	Yes	Yes	Yes	Yes	Yes	Yes	—	Yes	—	Yes	Yes	Yes
OC12 LR/STM4 LH 1310	Yes	Yes	Yes	Yes	Yes	Yes	Yes	Yes	Yes	—	Yes	—	Yes	Yes	Yes
OC12 LR/STM4 LH 1550	Yes	Yes	Yes	Yes	Yes	Yes	Yes	Yes	Yes	—	Yes	—	Yes	Yes	Yes
OC12 IR/STM4 SH 1310-4	—	—	—	—	—	Yes	Yes	Yes	Yes	—	Yes	—	Yes	Yes	Yes
OC48 IR 1310	Yes	Yes	Yes	Yes	Yes	Yes	Yes	Yes	Yes	—	Yes	—	Yes	Yes	Yes
OC48 LR 1550	Yes	Yes	Yes	Yes	Yes	Yes	Yes	Yes	Yes	—	Yes	—	Yes	Yes	Yes
OC48 IR/STM16 SH AS 1310 ²	—	—	—	Yes	Yes	Yes	Yes	Yes	Yes	—	Yes	—	Yes	Yes	Yes
OC48 LR/STM16 LH AS 1550 ³	—	—	—	Yes	Yes	Yes	Yes	Yes	Yes	—	Yes	—	Yes	Yes	Yes
OC48 ELR/STM16 EH 100 GHz	Yes	Yes	Yes	Yes	Yes	Yes	Yes	Yes	Yes	—	Yes	—	Yes	Yes	Yes
OC48 ELR 200 GHz	Yes	Yes	Yes	Yes	Yes	Yes	Yes	Yes	Yes	—	Yes	—	Yes	Yes	Yes
OC192 SR/STM64 IO 1310	—	—	—	—	—	—	—	Yes	Yes	—	Yes	—	Yes	Yes	Yes
OC192 IR/STM64 SH 1550	—	—	—	—	—	—	—	Yes	Yes	—	Yes	—	Yes	Yes	Yes
OC192 LR/STM64 LH 1550 (15454-OC192LR1550)	—	—	—	Yes	Yes	Yes	Yes	Yes	Yes	—	Yes	—	Yes	Yes	Yes
OC192 LR/STM64 LH 1550 (15454-OC192-LR2)	—	—	—	—	—	—	—	Yes	Yes	—	Yes	—	Yes	Yes	Yes
OC192 LR/STM64 LH ITU 15xx.xx	—	—	—	—	—	—	—	Yes	Yes	—	Yes	—	Yes	Yes	Yes
15454_MRC-12	—	—	—	—	—	—	—	—	—	—	—	—	—	Yes	Yes
OC192SR1/STM64IO Short Reach and OC192/STM64 Any Reach ⁴	—	—	—	—	—	—	—	—	—	—	—	—	—	Yes	Yes

1. DWDM-only release.

2. To enable OC-192 and OC-48 any-slot card operation, use the XC10G or XC-VXC-10G card, the TCC+/TCC2/TCC2P card, Software R3.1 or later, and the 15454-SA-ANSI or 154545-SA-HD shelf assembly. Note that the TCC+ card is not compatible with Software 4.5 or later.

3. To enable OC-192 and OC-48 any-slot card operation, use the XC10G or XC-VXC-10G card, the TCC+/TCC2/TCC2P card, Software R3.1 or later, and the 15454-SA-ANSI or 154545-SA-HD shelf assembly. Note that the TCC+ card is not compatible with Software 4.5 or later.

4. These cards are designated as OC192-XFP in CTC.

4.2 OC3 IR 4/STM1 SH 1310 Card



Note

For hardware specifications, see the “A.6.1 OC3 IR 4/STM1 SH 1310 Card Specifications” section on page A-26. See Table 4-2 on page 4-4 for optical card compatibility.

The OC3 IR 4/STM1 SH 1310 card provides four intermediate or short range SONET/SDH OC-3 ports compliant with ITU-T G.707, ITU-T G.957, and Telcordia GR-253-CORE. Each port operates at 155.52 Mbps over a single-mode fiber span. The card supports Virtual Tributary (VT), nonconcatenated (STS-1), or concatenated (STS-1 or STS-3c) payloads. Figure 4-1 shows the OC3 IR 4/STM1 SH 1310 faceplate and a block diagram of the card.

**Note**

The OC3 IR 4 SH 1310 and OC3 IR 4/STM1 SH 1310 cards are functionally the same.

**Warning**

The laser is on when the optical card is booted. The port does not have to be in service for the laser to be on.

Figure 4-1 OC3 IR 4/STM1 SH 1310 Faceplate and Block Diagram

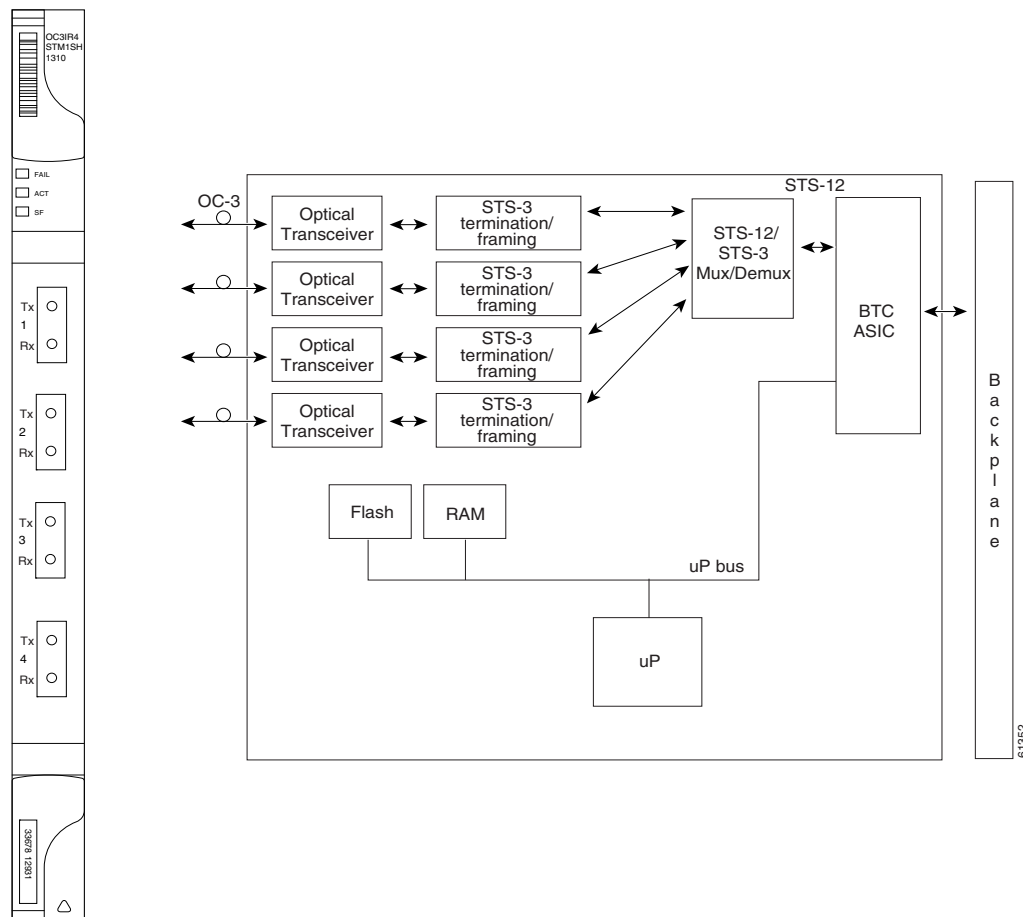

You can install the OC3 IR 4/STM1 SH 1310 card in Slots 1 to 6 and 12 to 17. The card can be provisioned as part of a path protection or in a linear add/drop multiplexer (ADM) configuration. Each interface features a 1310-nm laser and contains a transmit and receive connector (labeled) on the card faceplate. The card uses SC connectors.

The OC3 IR 4/STM1 SH 1310 card supports 1+1 unidirectional or bidirectional protection switching. You can provision protection on a per port basis.

The OC3 IR 4/STM1 SH 1310 card detects loss of signal (LOS), loss of frame (LOF), loss of pointer (LOP), line-layer alarm indication signal (AIS-L), and line-layer remote defect indication (RDI-L) conditions. Refer to the *Cisco ONS 15454 Troubleshooting Guide* for a description of these conditions. The card also counts section and line bit interleaved parity (BIP) errors.

To enable automatic protection switching (APS), the OC3 IR 4/STM1 SH 1310 card extracts the K1 and K2 bytes from the SONET overhead to perform appropriate protection switches. The data communication channel/general communication channel (DCC/GCC) bytes are forwarded to the TCC2/TCC2P card, which terminates the DCC/GCC.

4.2.1 OC3 IR 4/STM1 SH 1310 Card-Level Indicators

Table 4-3 describes the three card-level LED indicators on the OC3 IR 4/STM1 SH 1310 card.

Table 4-3 OC3 IR 4/STM1 SH 1310 Card-Level Indicators

Card-Level Indicators	Description
Red FAIL LED	The red FAIL LED indicates that the card's processor is not ready. This LED is on during reset. The FAIL LED flashes during the boot process. Replace the card if the red FAIL LED persists.
Green ACT LED	The green ACT LED indicates that the card is carrying traffic or is traffic-ready.
Amber SF LED	The amber SF LED indicates a signal failure or condition such as LOS, LOF, AIS-L, or high bit error rate (BER) on one or more of the card's ports. The amber SF LED is also on if the transmit and receive fibers are incorrectly connected. If the fibers are properly connected and the links are working, the light turns off.

4.2.2 OC3 IR 4/STM1 SH 1310 Port-Level Indicators

Eight bicolor LEDs show the status per port. The LEDs are green if the port is available to carry traffic, is provisioned as in-service, and is part of a protection group, in the active mode. You can find the status of the four card ports by using the LCD screen on the ONS 15454 fan-tray assembly. Use the LCD to view the status of any port or card slot; the screen displays the number and severity of alarms for a given port or slot. Refer to the *Cisco ONS 15454 Troubleshooting Guide* for a complete description of the alarm messages.

4.3 OC3 IR/STM1 SH 1310-8 Card



Note

For hardware specifications, see the “[A.6.2 OC3 IR/STM1 SH 1310-8 Card Specifications](#)” section on [page A-27](#). See [Table 4-2 on page 4-4](#) for optical card compatibility.

The OC3 IR/STM1 SH 1310-8 card provides eight intermediate or short range SONET/SDH OC-3 ports compliant with ITU-T G.707, ITU-T G.957, and Telcordia GR-253-CORE. Each port operates at 155.52 Mbps over a single-mode fiber span. The card supports VT, nonconcatenated (STS-1), or concatenated (STS-3C) payloads.

**Warning**

The laser is on when the optical card is booted. The port does not have to be in service for the laser to be on.

Figure 4-2 shows the card faceplate and block diagram.

Figure 4-2 OC3IR/STM1 SH 1310-8 Faceplate and Block Diagram

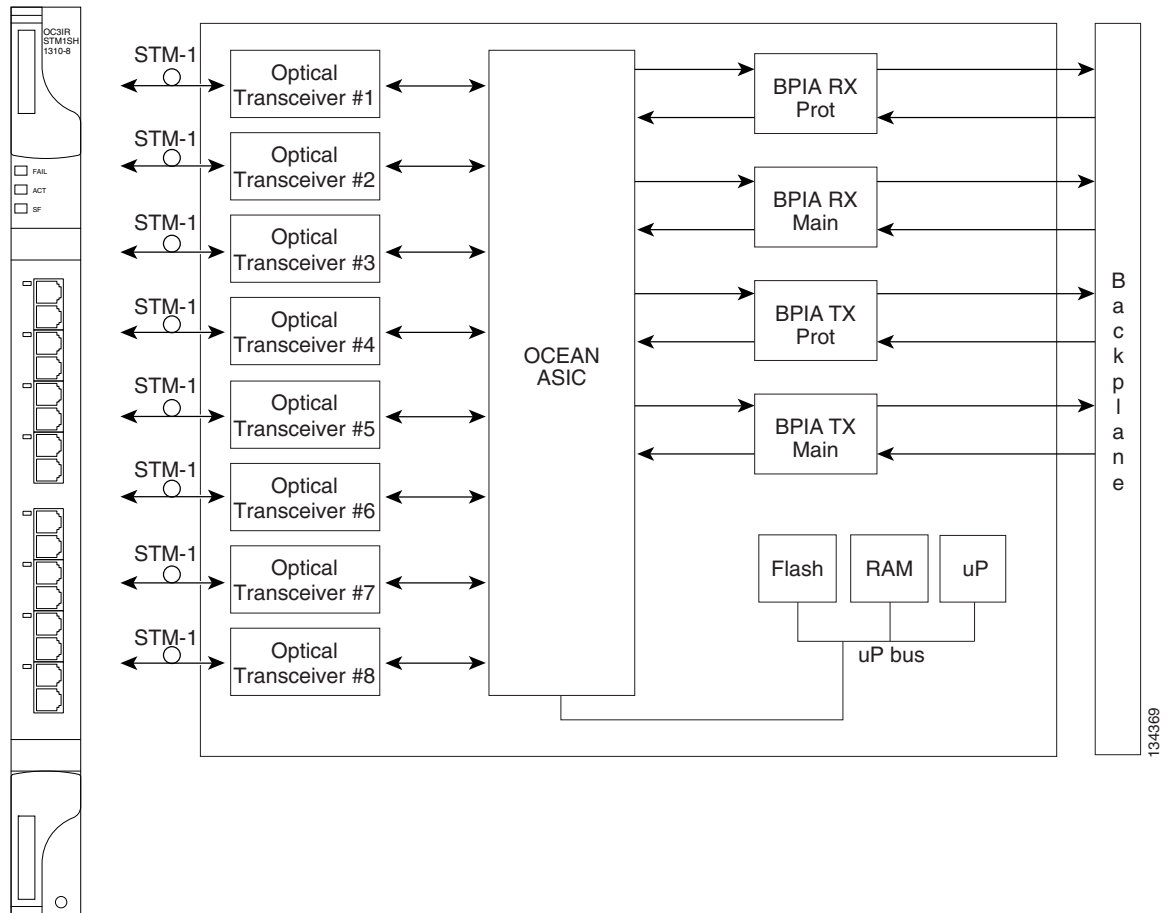

You can install the OC3 IR/STM1 SH 1310-8 card in Slots 1 to 4 and 14 to 17. The card can be provisioned as part of a path protection or in an ADM configuration. Each interface features a 1310-nm laser and contains a transmit and receive connector (labeled) on the card faceplate. The card uses LC connectors on the faceplate that are angled downward 12.5 degrees.

The OC3 IR/STM1 SH 1310-8 card supports 1+1 unidirectional and bidirectional protection switching. You can provision protection on a per port basis.

The OC3 IR/STM1 SH 1310-8 card detects LOS, LOF, LOP, AIS-L, and RDI-L conditions. Refer to the *Cisco ONS 15454 Troubleshooting Guide* for a description of these conditions. The card also counts section and line BIP errors.

To enable APS, the OC3 IR/STM1 SH 1310-8 card extracts the K1 and K2 bytes from the SONET overhead to perform appropriate protection switches. The OC3 IR/STM1 SH 1310-8 card supports full DCC/GCC connectivity for remote network management.

4.3.1 OC3 IR/STM1 SH 1310-8 Card-Level Indicators

Table 4-4 describes the three card-level LEDs on the eight-port OC3 IR/STM1 SH 1310-8 card.

Table 4-4 OC3IR/STM1 SH 1310-8 Card-Level Indicators

Card-Level LED	Description
Red FAIL LED	The red FAIL LED indicates that the card's processor is not ready. This LED is on during reset. The FAIL LED flashes during the boot process. Replace the card if the red FAIL LED persists.
Green ACT LED	The green ACT LED indicates that the card is carrying traffic or is traffic-ready.
Amber SF LED	The amber SF LED indicates a signal failure or condition such as LOS, LOF, AIS-L, or high BER on one or more of the card's ports. The amber SF LED is also on if the transmit and receive fibers are incorrectly connected. If the fibers are properly connected and the links are working, the light turns off.

4.3.2 OC3 IR/STM1 SH 1310-8 Port-Level Indicators

Eight bicolor LEDs show the status per port. The LEDs show green if the port is available to carry traffic, is provisioned as in-service, is part of a protection group, or is in the active mode. You can also find the status of the eight card ports by using the LCD screen on the ONS 15454 fan-tray assembly. Use the LCD to view the status of any port or card slot; the screen displays the number and severity of alarms for a given port or slot. Refer to the *Cisco ONS 15454 Troubleshooting Guide* for a complete description of the alarm messages.

4.4 OC12 IR/STM4 SH 1310 Card



Note

For hardware specifications, see the “[A.6.3 OC12 IR/STM4 SH 1310 Card Specifications](#)” section on [page A-28](#). See [Table 4-2 on page 4-4](#) for optical card compatibility.

The OC12 IR/STM4 SH 1310 card provides one intermediate or short range SONET OC-12 port compliant with ITU-T G.707, ITU-T G.957, and Telcordia GR-253-CORE. The port operates at 622.08 Mbps over a single-mode fiber span. The card supports VT, nonconcatenated (STS-1), or concatenated (STS-3c, STS-6c, or STS-12c) payloads. [Figure 4-3](#) shows the OC12 IR/STM4 SH 1310 faceplate and a block diagram of the card.



Note

The OC12 IR 1310 and OC12/STM4 SH 1310 cards are functionally the same.



Warning

The laser is on when the optical card is booted. The port does not have to be in service for the laser to be on.

Figure 4-3 OC12 IR/STM4 SH 1310 Faceplate and Block Diagram

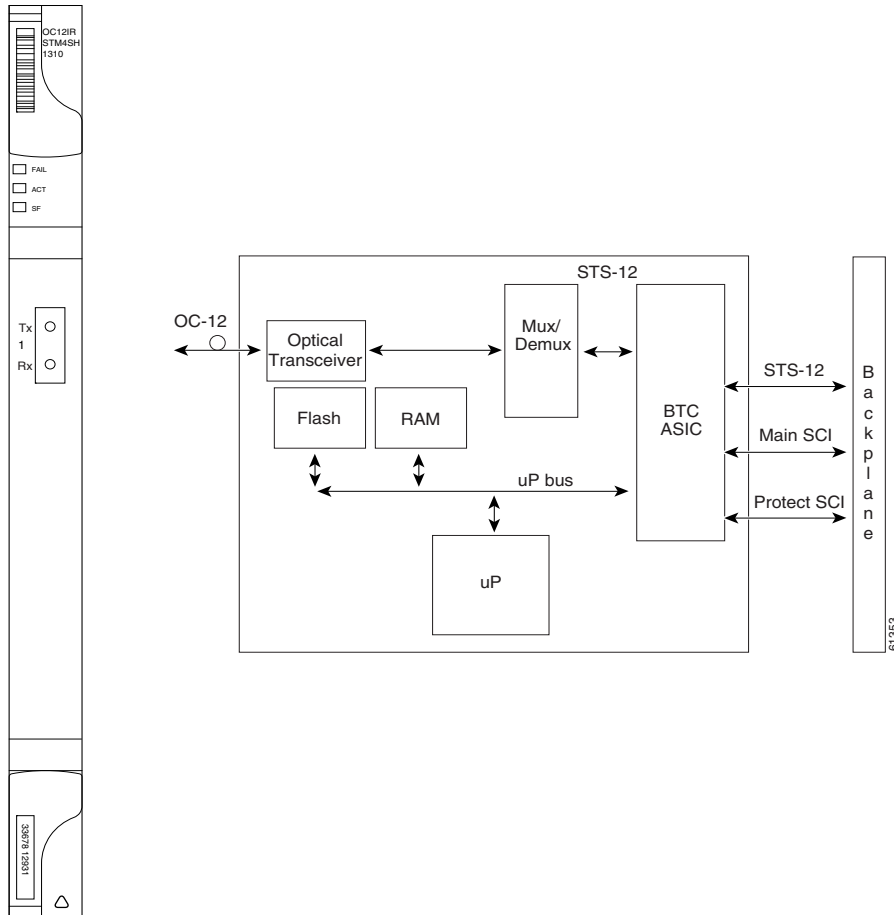

You can install the OC12 IR/STM4 SH 1310 card in Slots 1 to 6 and 12 to 17, and provision the card as a drop card or span card in a two-fiber BLSR, path protection, or ADM (linear) configuration.

The OC12 IR/STM4 SH 1310 card interface features a 1310-nm laser and contains a transmit and receive connector (labeled) on the card faceplate. The OC12 IR/STM4 SH 1310 card uses SC optical connections and supports 1+1 unidirectional and bidirectional protection.

The OC12 IR/STM4 SH 1310 detects LOS, LOF, LOP, AIS-L, and RDI-L conditions. Refer to the *Cisco ONS 15454 Troubleshooting Guide* for a description of these conditions. The card also counts section and line BIT errors.

To enable APS, the OC12 IR/STM4 SH 1310 card extracts the K1 and K2 bytes from the SONET overhead to perform appropriate protection switches. The DCC/GCC bytes are forwarded to the TCC2/TCC2P card, which terminates the DCC/GCC.

4.4.1 OC12 IR/STM4 SH 1310 Card-Level Indicators

Table 4-5 describes the three card-level LEDs on the OC12 IR/STM4 SH 1310 card.

Table 4-5 OC12 IR/STM4 SH 1310 Card-Level Indicators

Card-Level Indicators	Description
Red FAIL LED	The red FAIL LED indicates that the card's processor is not ready. This LED is on during reset. The FAIL LED flashes during the boot process. Replace the card if the red FAIL LED persists.
Green/Amber ACT LED	The green ACT LED indicates that the card is operational and is carrying traffic or is traffic-ready. The amber ACT LED indicates that the card is part of an active ring switch (BLSR).
Amber SF LED	The amber SF LED indicates a signal failure or condition such as LOS, LOF, AIS-L, or high BERs on one or more of the card's ports. The amber SF LED is also on if the transmit and receive fibers are incorrectly connected. If the fibers are properly connected and the link is working, the light turns off.

4.4.2 OC12 IR/STM4 SH 1310 Port-Level Indicators

You can find the status of the OC-12 IR/STM4 SH 1310 card port by using the LCD screen on the ONS 15454 fan-tray assembly. Use the LCD to view the status of any port or card slot; the screen displays the number and severity of alarms for a given port or slot. Refer to the *Cisco ONS 15454 Troubleshooting Guide* for a complete description of the alarm messages.

4.5 OC12 LR/STM4 LH 1310 Card



Note

For hardware specifications, see the “A.6.4 OC12 LR/STM4 LH 1310 Card Specifications” section on page A-29. See Table 4-2 on page 4-4 for optical card compatibility.

The OC12 LR/STM4 LH 1310 card provides one long-range SONET OC-12 port per card compliant with ITU-T G.707, ITU-T G.957, and Telcordia GR-253-CORE. The port operates at 622.08 Mbps over a single-mode fiber span. The card supports VT, nonconcatenated (STS-1), or concatenated (STS-3c, STS-6c, or STS-12c) payloads. Figure 4-4 shows the OC12 LR/STM4 LH 1310 faceplate and a block diagram of the card.



Note

The OC12 LR 1310 and OC12 LR/STM4 LH 1310 cards are functionally the same.



Warning

The laser is on when the optical card is booted. The port does not have to be in service for the laser to be on.

Figure 4-4 OC12 LR/STM4 LH 1310 Faceplate and Block Diagram

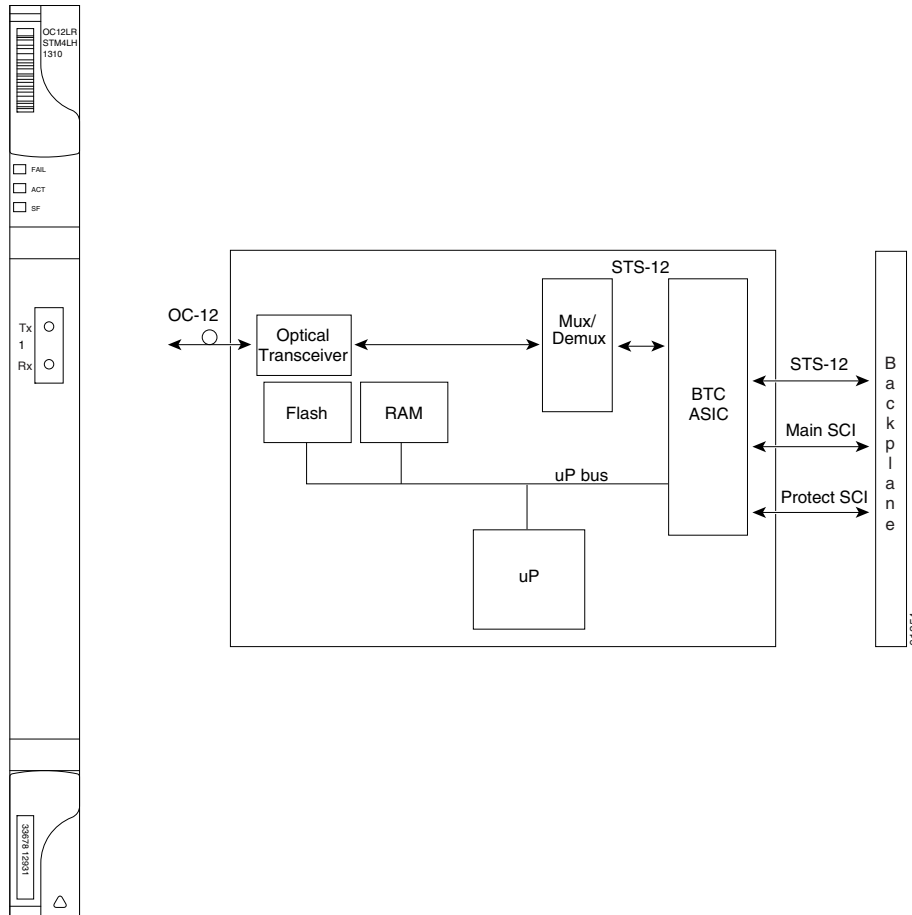

You can install the OC12 LR/STM4 LH 1310 card in Slots 1 to 6 and 12 to 17, and provision the card as a drop card or span card in a two-fiber BLSR, path protection, or ADM (linear) configuration.

The OC12 LR/STM4 LH 1310 card interface features a 1310-nm laser and contains a transmit and receive connector (labeled) on the card faceplate. The card uses SC optical connections and supports 1+1 unidirectional and bidirectional protection.

The OC12 LR/STM4 LH 1310 card detects LOS, LOF, LOP, AIS-L, and RDI-L conditions. Refer to the *Cisco ONS 15454 Troubleshooting Guide* for a description of these conditions. The card also counts section and line BIT errors.

To enable APS, the OC12 LR/STM4 LH 1310 card extracts the K1 and K2 bytes from the SONET overhead to perform appropriate protection switches. The DCC/GCC bytes are forwarded to the TCC2/TCC2P card, which terminates the DCC/GCC.

4.5.1 OC12 LR/STM4 LH 1310 Card-Level Indicators

Table 4-6 describes the three card-level LEDs on the OC12 LR/STM4 LH 1310 card.

Table 4-6 OC12 LR/STM4 LH 1310 Card-Level Indicators

Card-Level Indicators	Description
Red FAIL LED	The red FAIL LED indicates that the card's processor is not ready. Replace the card if the red FAIL LED persists.
Green/Amber ACT LED	The green ACT LED indicates that the card is operational and is carrying traffic or is traffic-ready. The amber ACT LED indicates that the card is part of an active ring switch (BLSR).
Amber SF LED	The amber SF LED indicates a signal failure or condition such as LOS, LOF, AIS-L, or high BERs on the card's port. The amber SF LED is also on if the transmit and receive fibers are incorrectly connected. If the fibers are properly connected, the light turns off.

4.5.2 OC12 LR/STM4 LH 1310 Port-Level Indicators

You can find the status of the OC12 LR/STM4 LH 1310 card port by using the LCD screen on the ONS 15454 fan-tray assembly. Use the LCD to quickly view the status of any port or card slot; the screen displays the number and severity of alarms for a given port or slot.

4.6 OC12 LR/STM4 LH 1550 Card



Note

For hardware specifications, see the “[A.6.5 OC12 LR/STM4 LH 1550 Card Specifications](#)” section on [page A-30](#). See [Table 4-2 on page 4-4](#) for optical card compatibility.

The OC12 LR/STM4 LH 1550 card provides one long-range SONET/SDH OC-12 port compliant with ITU-T G.707, ITU-T G.957, and Telcordia GR-253-CORE. The port operates at 622.08 Mbps over a single-mode fiber span. The card supports VT, nonconcatenated (STS-1), or concatenated (STS-3c, STS-6c, or STS-12c) payloads. [Figure 4-5](#) shows the OC12 LR/STM4 LH 1550 faceplate and a block diagram of the card.



Note

The OC12 LR 1550 and OC12 LR/STM4 LH 1550 cards are functionally the same.



Warning

The laser is on when the optical card is booted. The port does not have to be in service for the laser to be on.

Figure 4-5 OC12 LR/STM4 LH 1550 Faceplate and Block Diagram

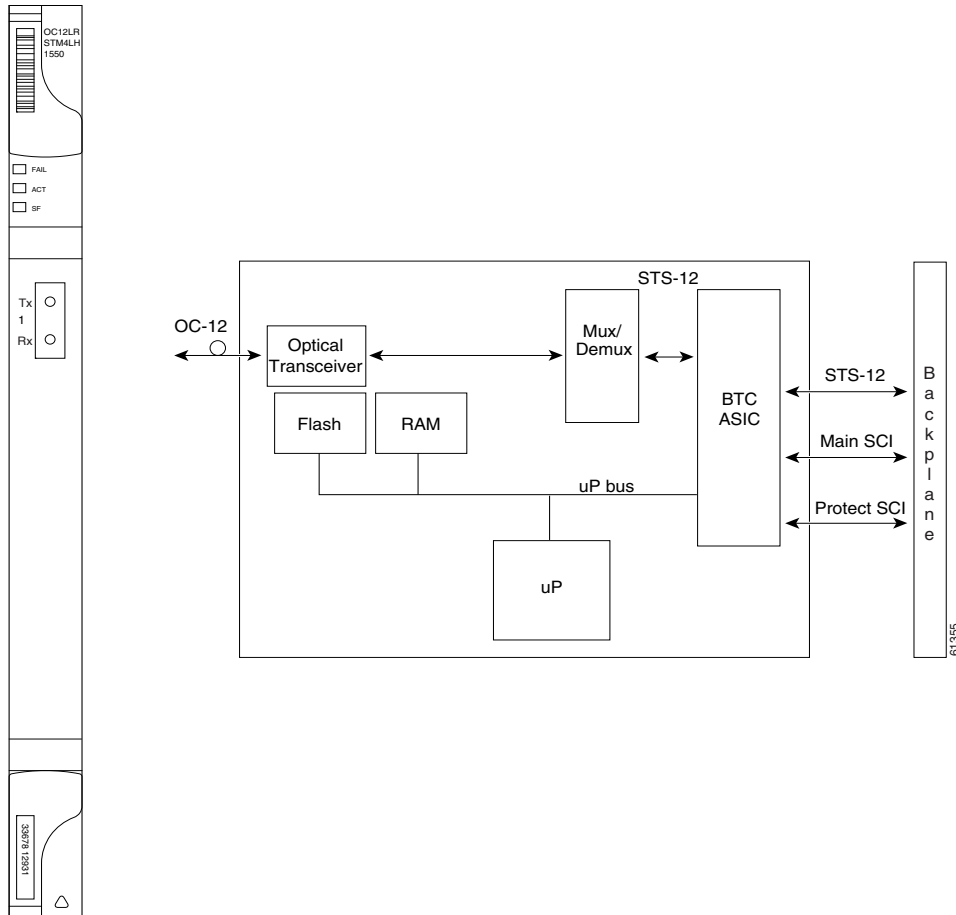

You can install the OC12 LR/STM4 LH 1550 card in Slots 1 to 4 and 14 to 17. The OC12 LR/STM4 LH 1550 can be provisioned as part of a two-fiber BLSR, path protection, or linear ADM.

The OC12 LR/STM4 LH 1550 uses long-reach optics centered at 1550 nm and contains a transmit and receive connector (labeled) on the card faceplate. The OC12 LR/STM4 LH 1550 uses SC optical connections and supports 1+1 bidirectional or unidirectional protection switching.

The OC12 LR/STM4 LH 1550 detects LOS, LOF, LOP, AIS-L, and RDI-L conditions. The card also counts section and line BIT errors.

4.6.1 OC12 LR/STM4 LH 1550 Card-Level Indicators

Table 4-7 describes the three card-level LEDs on the OC12 LR/STM4 LH 1550 card.

Table 4-7 OC12 LR/STM4 LH 1550 Card-Level Indicators

Card-Level Indicators	Description
Red FAIL LED	The red FAIL LED indicates that the card's processor is not ready. Replace the card if the red FAIL LED persists.
Green/Amber ACT LED	The green ACT LED indicates that the card is operational and ready to carry traffic. The amber ACT LED indicates that the card is part of an active ring switch (BLSR).
Amber SF LED	The amber SF LED indicates a signal failure or condition such as LOS, LOF, AIS-L, or high BERs on the card's port. The amber SF LED is also on if the transmit and receive fibers are incorrectly connected. If the fibers are properly connected, the light turns off.

4.6.2 OC12 LR/STM4 LH 1550 Port-Level Indicators

You can find the status of the OC12 LR/STM4 LH 1550 card port by using the LCD screen on the ONS 15454 fan-tray assembly. Use the LCD to view the status of any port or card slot; the screen displays the number and severity of alarms for a given port or slot.

4.7 OC12 IR/STM4 SH 1310-4 Card



Note

For hardware specifications, see the “[A.6.6 OC12 IR/STM4 SH 1310-4 Specifications](#)” section on [page A-31](#). See [Table 4-2 on page 4-4](#) for optical card compatibility.

The OC12 IR/STM4 SH 1310-4 card provides four intermediate or short range SONET/SDH OC-12/STM-4 ports compliant with the ITU-T G.707, ITU-T G.957, and Telcordia GR-253-CORE. Each port operates at 622.08 Mbps over a single-mode fiber span. The card supports VT, nonconcatenated (STS-1), or concatenated (STS-1, STS-3c, STS-6c, or STS-12c) payloads.



Warning

The laser is on when the optical card is booted. The port does not have to be in service for the laser to be on.

[Figure 4-6](#) shows the OC12 IR/STM4 SH 1310-4 faceplate and a block diagram of the card.

Figure 4-6 OC12 IR/STM4 SH 1310-4 Faceplate and Block Diagram

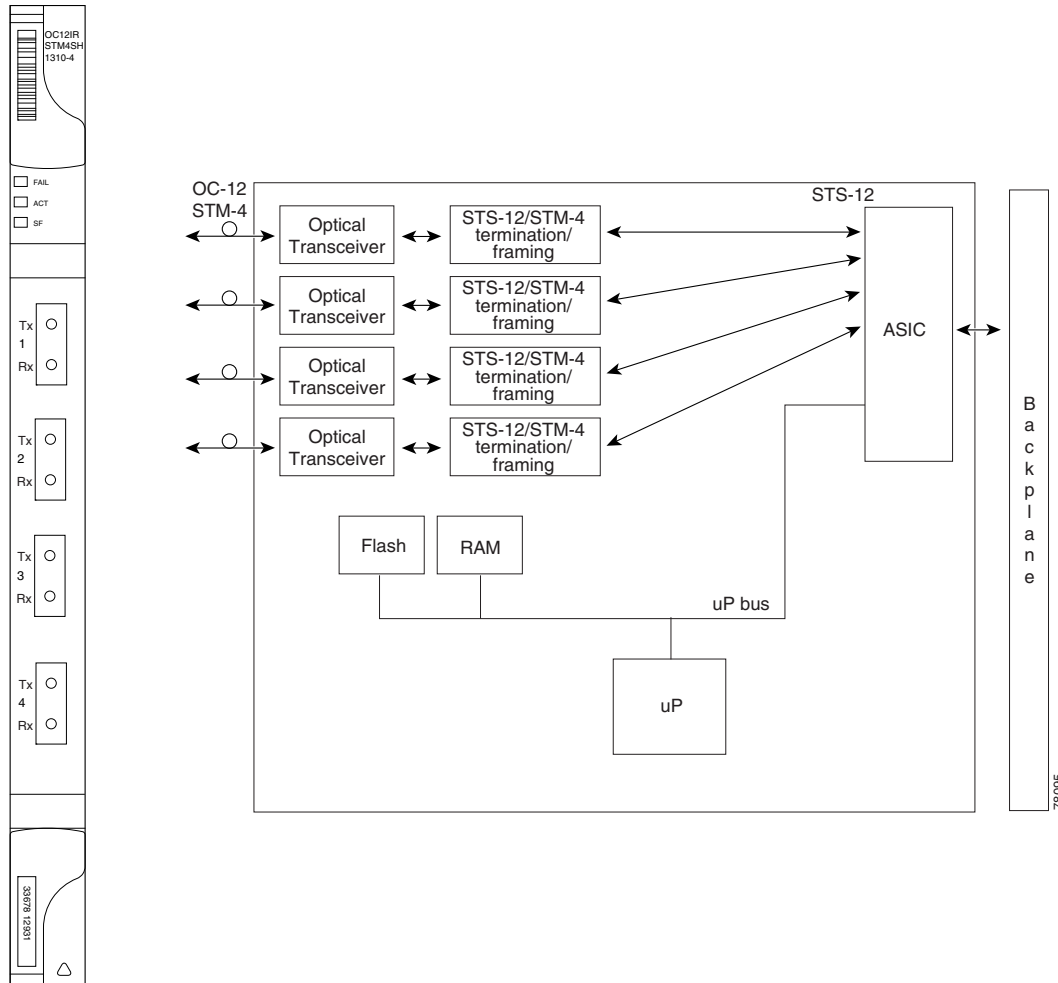

You can install the OC12 IR/STM4 SH 1310-4 card in Slots 1 to 4 and 14 to 17. Each interface features a 1310-nm laser and contains a transmit and receive connector (labeled) on the card faceplate. The card uses SC connectors.

The OC12 IR/STM4 SH 1310-4 card supports 1+1 unidirectional and bidirectional protection switching. You can provision protection on a per port basis.

The OC12 IR/STM4 SH 1310-4 card detects LOS, LOF, LOP, MS-AIS, and MS-FERF conditions. Refer to the *Cisco ONS 15454 Troubleshooting Guide* for a description of these conditions. The card also counts section and line BIP errors.

To enable BLSR, the OC12 IR/STM4 SH 1310-4 card extracts the K1 and K2 bytes from the SONET overhead and processes them to switch accordingly. The DCC/GCC bytes are forwarded to the TCC2/TCC2P card, which terminates the DCC/GCC.



Note

If you ever expect to upgrade an OC-12/STM-4 ring to a higher bit rate, you should not put an OC12 IR/STM4 SH 1310-4 card in that ring. The four-port card is not upgradable to a single-port card. The reason is that four different spans, possibly going to four different nodes, cannot be merged to a single span.

4.7.1 OC12 IR/STM4 SH 1310-4 Card-Level Indicators

Table 4-8 describes the three card-level LEDs on the OC12 IR/STM4 SH 1310-4 card.

Table 4-8 OC12 IR/STM4 SH 1310-4 Card-Level Indicators

Card-Level Indicators	Description
Red FAIL LED	The red FAIL LED indicates that the card's processor is not ready. Replace the card if the red FAIL LED persists.
Green ACT LED	The green ACT LED indicates that the card is carrying traffic or is traffic-ready.
Amber SF LED	The amber SF LED indicates a signal failure or condition such as LOS, LOF, AIS-L, or high BER on one or more of the card's ports. The amber SF LED is also on if the transmit and receive fibers are incorrectly connected. If the fibers are properly connected, the light turns off.

4.7.2 OC12 IR/STM4 SH 1310-4 Port-Level Indicators

You can find the status of the four card ports by using the LCD screen on the ONS 15454 fan-tray assembly. Use the LCD to view the status of any port or card slot; the screen displays the number and severity of alarms for a given port or slot.

4.8 OC48 IR 1310 Card



Note

For hardware specifications, see the “A.6.7 OC48 IR 1310 Card Specifications” section on page A-32. See Table 4-2 on page 4-4 for optical card compatibility.



Note

Any new features that are available as part of this software release are not enabled for this card.

The OC48 IR 1310 card provides one intermediate-range, SONET OC-48 port per card, compliant with Telcordia GR-253-CORE. Each port operates at 2.49 Gbps over a single-mode fiber span. The card supports VT, nonconcatenated (STS-1), or concatenated (STS-3c, STS-6c, STS-12c, or STS-48c) payloads.



Warning

The laser is on when the optical card is booted. The port does not have to be in service for the laser to be on.

Figure 4-7 shows the OC48 IR 1310 faceplate and a block diagram of the card.

Figure 4-7 OC48 IR 1310 Faceplate and Block Diagram

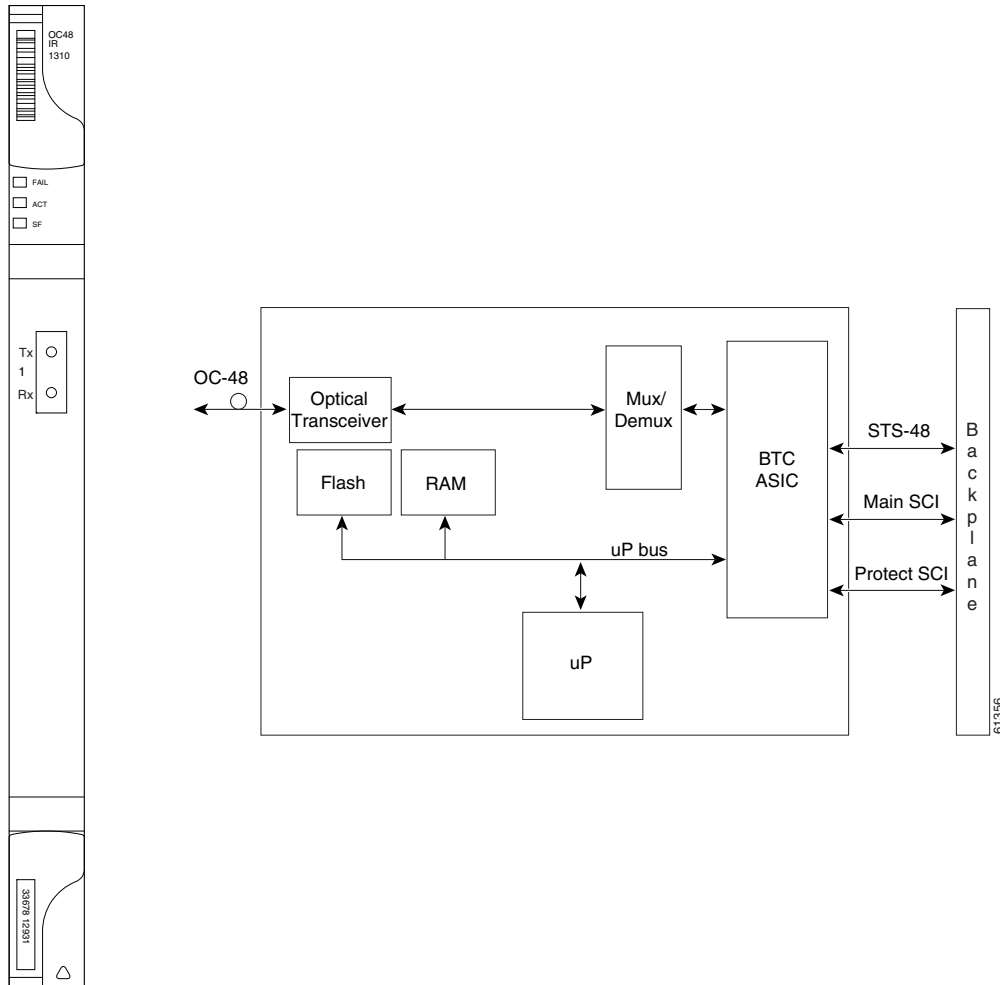

You can install the OC48 IR 1310 card in Slots 5, 6, 12, and 13, and provision the card as a drop or span card in a two-fiber or four-fiber BLSR, path protection, or in an ADM (linear) configuration.

The OC-48 port features a 1310-nm laser and contains a transmit and receive connector (labeled) on the card faceplate. The OC48 IR 1310 uses SC connectors. The card supports 1+1 unidirectional and bidirectional protection switching.

The OC48 IR 1310 detects LOS, LOF, LOP, AIS-L, and RDI-L conditions. The card also counts section and line BIP errors.

4.8.1 OC48 IR 1310 Card-Level Indicators

Table 4-9 describes the three card-level LEDs on the OC48 IR 1310 card.

Table 4-9 OC48 IR 1310 Card-Level Indicators

Card-Level Indicators	Description
Red FAIL LED	The red FAIL LED indicates that the card's processor is not ready. Replace the card if the red FAIL LED persists.
Green/Amber ACT LED	The green ACT LED indicates that the card is carrying traffic or is traffic-ready. The amber ACT LED indicates that the card is part of an active ring switch (BLSR).
Amber SF LED	The amber SF LED indicates a signal failure or condition such as LOS, LOF, AIS-L, or high BERs on the card's port. The amber SF LED is also on if the transmit and receive fibers are incorrectly connected. If the fibers are properly connected, the light turns off.

4.8.2 OC48 IR 1310 Port-Level Indicators

You can find the status of the OC48 IR 1310 card port by using the LCD screen on the ONS 15454 fan-tray assembly. Use the LCD to view the status of any port or card slot; the screen displays the number and severity of alarms for a given port or slot.

4.9 OC48 LR 1550 Card



Note

For hardware specifications, see the “[A.6.8 OC48 LR 1550 Card Specifications](#)” section on page A-33. See [Table 4-2 on page 4-4](#) for optical card compatibility.



Note

Any new features that are available as part of this software release are not enabled for this card.

The OC48 LR 1550 card provides one long-range, SONET OC-48 port per card, compliant with Telcordia GR-253-CORE. Each port operates at 2.49 Gbps over a single-mode fiber span. The card supports VT, nonconcatenated (STS-1), or concatenated (STS-3c, STS-6c, STS-12c, or STS-48c) payloads.



Warning

The laser is on when the optical card is booted. The port does not have to be in service for the laser to be on.

[Figure 4-8](#) shows the OC48 LR 1550 faceplate and a block diagram of the card.

Figure 4-8 OC48 LR 1550 Faceplate and Block Diagram

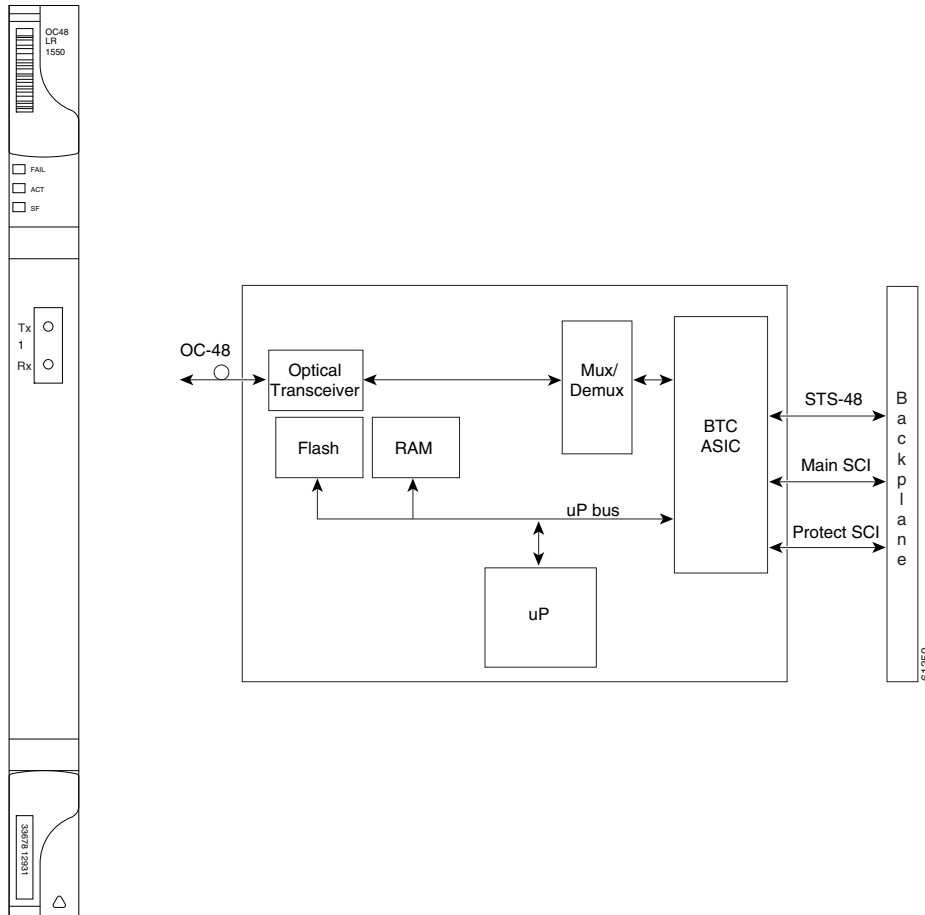

You can install OC48 LR 1550 cards in Slots 5, 6, 12, and 13 and provision the card as a drop or span card in a two-fiber or four-fiber BLSR, path protection, or ADM (linear) configuration.

The OC48 LR 1550 port features a 1550-nm laser and contains a transmit and receive connector (labeled) on the card faceplate. The card uses SC connectors, and it supports 1+1 unidirectional and bidirectional protection switching.

The OC48 LR 1550 detects LOS, LOF, LOP, AIS-L, and RDI-L conditions. The card also counts section and line BIP errors.

4.9.1 OC48 LR 1550 Card-Level Indicators

Table 4-10 describes the three card-level LEDs on the OC48 LR 1550 card.

Table 4-10 OC48 LR 1550 Card-Level Indicators

Card-Level Indicators	Description
Red FAIL LED	The red FAIL LED indicates that the card's processor is not ready. Replace the card if the red FAIL LED persists.
Green/Amber ACT LED	The green ACT LED indicates that the card is carrying traffic or is traffic-ready. The amber ACT LED indicates that the card is part of an active ring switch (BLSR).
Amber SF LED	The amber SF LED indicates a signal failure or condition such as LOS, LOF, or high BERs on the card's port. The amber SF LED is also on if the transmit and receive fibers are incorrectly connected. If the fibers are properly connected, the light turns off.

4.9.2 OC48 LR 1550 Port-Level Indicators

You can find the status of the OC48 LR 1550 card port by using the LCD screen on the ONS 15454 fan-tray assembly. Use the LCD to view the status of any port or card slot; the screen displays the number and severity of alarms for a given port or slot.

4.10 OC48 IR/STM16 SH AS 1310 Card



Note

For hardware specifications, see the “[A.6.9 OC48 IR/STM16 SH AS 1310 Card Specifications](#)” section on page A-33. See [Table 4-2 on page 4-4](#) for optical card compatibility.

The OC48 IR/STM16 SH AS 1310 card provides one intermediate-range SONET/SDH OC-48 port compliant with ITU-T G.707, ITU-T G.957, and Telcordia GR-253-CORE. The port operates at 2.49 Gbps over a single-mode fiber span. The card supports VT, nonconcatenated (STS-1), or concatenated (STS-3c, STS-6c, STS-12c, or STS-48c) payloads.



Warning

The laser is on when the optical card is booted. The port does not have to be in service for the laser to be on.

[Figure 4-9](#) shows the OC48 IR/STM16 SH AS 1310 faceplate and a block diagram of the card.

Figure 4-9 OC48 IR/STM16 SH AS 1310 Faceplate and Block Diagram

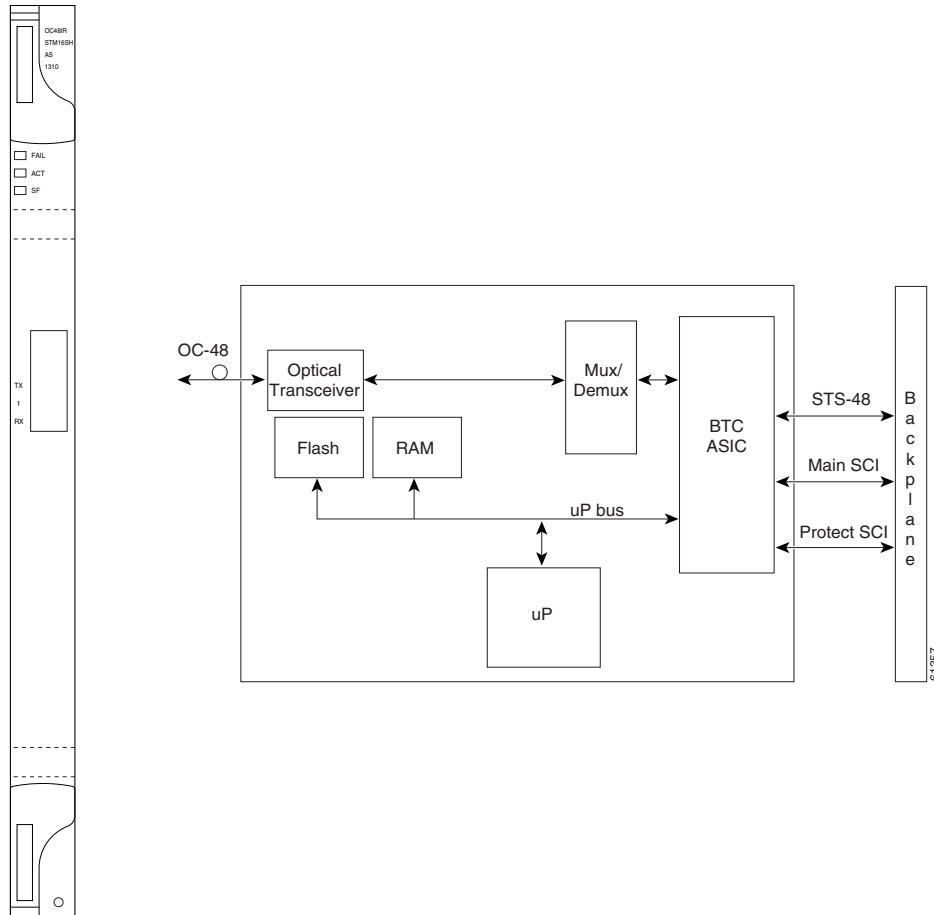

You can install the OC48 IR/STM16 SH AS 1310 card in Slots 1 to 6 and 12 to 17 and provision the card as a drop or span card in a two-fiber or four-fiber BLSR, path protection, or ADM (linear) configuration.

The OC-48 port features a 1310-nm laser and contains a transmit and receive connector (labeled) on the card faceplate. The OC48 IR/STM16 SH AS 1310 uses SC connectors. The card supports 1+1 unidirectional and bidirectional protection switching.

The OC48 IR/STM16 SH AS 1310 detects LOS, LOF, LOP, AIS-L, and RDI-L conditions. The card also counts section and line BIP errors.

4.10.1 OC48 IR/STM16 SH AS 1310 Card-Level Indicators

Table 4-11 lists the three card-level LEDs on the OC48 IR/STM16 SH AS 1310 card.

Table 4-11 OC48 IR/STM16 SH AS 1310 Card-Level Indicators

Card-Level Indicators	Description
Red FAIL LED	The red FAIL LED indicates that the card's processor is not ready. Replace the card if the red FAIL LED persists.
Green/Amber ACT LED	The green ACT LED indicates that the card is carrying traffic or is traffic-ready. The amber ACT LED indicates that the card is part of an active ring switch (BLSR).
Amber SF LED	The amber SF LED indicates a signal failure or condition such as LOS, LOF, AIS-L, or high BERs on the card's port. The amber SF LED is also on if the transmit and receive fibers are incorrectly connected. If the fibers are properly connected, the light turns off.

4.10.2 OC48 IR/STM16 SH AS 1310 Port-Level Indicators

You can find the status of the OC48 IR/STM16 SH AS 1310 card port by using the LCD screen on the ONS 15454 fan-tray assembly. Use the LCD to view the status of any port or card slot; the screen displays the number and severity of alarms for a given port or slot.

4.11 OC48 LR/STM16 LH AS 1550 Card



Note

For hardware specifications, see the [“A.6.10 OC48 LR/STM16 LH AS 1550 Card Specifications” section on page A-34](#). See [Table 4-2 on page 4-4](#) for optical card compatibility.

The OC48 LR/STM16 LH AS 1550 card provides one long-range SONET/SDH OC-48 port compliant with ITU-T G.707, ITU-T G.957, and Telcordia GR-253-CORE. Each port operates at 2.49 Gbps over a single-mode fiber span. The card supports VT, nonconcatenated (STS-1), or concatenated (STS-3c, STS-6c, STS-12c, or STS-48c) payloads.



Warning

The laser is on when the optical card is booted. The port does not have to be in service for the laser to be on.

[Figure 4-10](#) shows a block diagram and the faceplate of the OC48 LR/STM16 LH AS 1550 card.

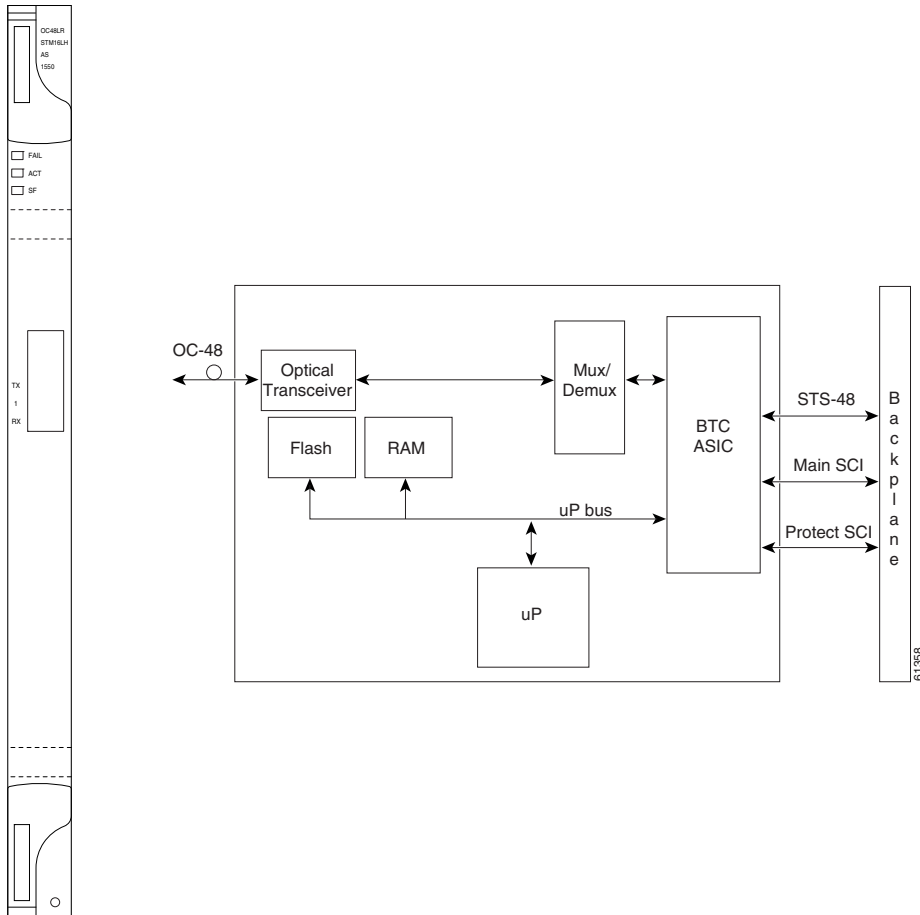
Figure 4-10 OC48 LR/STM16 LH AS 1550 Faceplate and Block Diagram

You can install OC48 LR/STM16 LH AS 1550 cards in Slots 1 to 6 and 12 to 17 and provision the card as a drop or span card in a two-fiber or four-fiber BLSR, path protection, or ADM (linear) configuration.

The OC48 LR/STM16 LH AS 1550 port features a 1550-nm laser and contains a transmit and receive connector (labeled) on the card faceplate. The card uses SC connectors, and it supports 1+1 unidirectional and bidirectional protection switching.

The OC48 LR/STM16 LH AS 1550 detects LOS, LOF, LOP, AIS-L, and RDI-L conditions. The card also counts section and line BIP errors.

4.11.1 OC48 LR/STM16 LH AS 1550 Card-Level Indicators

Table 4-12 describes the three card-level LEDs on the OC48 LR/STM16 LH AS 1550 card.

Table 4-12 OC48 LR/STM16 LH AS 1550 Card-Level Indicators

Card-Level Indicators	Description
Red FAIL LED	The red FAIL LED indicates that the card's processor is not ready. Replace the card if the red FAIL LED persists.
Green/Amber ACT LED	The green ACT LED indicates that the card is carrying traffic or is traffic-ready. The amber ACT LED indicates that the card is part of an active ring switch (BLSR).
Amber SF LED	The amber SF LED indicates a signal failure or condition such as LOS, LOF, or high BERs on the card's port. The amber SF LED is also on if the transmit and receive fibers are incorrectly connected. If the fibers are properly connected, the light turns off.

4.11.2 OC48 LR/STM16 LH AS 1550 Port-Level Indicators

You can find the status of the OC48 LR/STM16 LH AS 1550 card port by using the LCD screen on the ONS 15454 fan-tray assembly. Use the LCD to view the status of any port or card slot; the screen displays the number and severity of alarms for a given port or slot.

4.12 OC48 ELR/STM16 EH 100 GHz Cards



Note

For hardware specifications, see the [“A.6.11 OC48 ELR/STM 16 EH 100 GHz Card Specifications” section on page A-35](#). See [Table 4-2 on page 4-4](#) for optical card compatibility.

Thirty-seven distinct OC48 ELR/STM16 EH 100 GHz cards provide the ONS 15454 DWDM channel plan. Each OC48 ELR/STM16 EH 100 GHz card has one SONET OC-48/SDH STM-16 port that complies with Telcordia GR-253-CORE, ITU-T G.692, and ITU-T G.958.

The port operates at 2.49 Gbps over a single-mode fiber span. The card carries VT, concatenated (STS-1), and nonconcatenated (STS-1, STS-3c, STS-6c, STS-12c, or STS-48c) payloads.



Warning

The laser is on when the optical card is booted. The port does not have to be in service for the laser to be on.

[Figure 4-11](#) shows the OC48 ELR/STM16 EH 100 GHz faceplate and a block diagram of the card.

Figure 4-11 OC48 ELR/STM16 EH 100 GHz Faceplate and Block Diagram

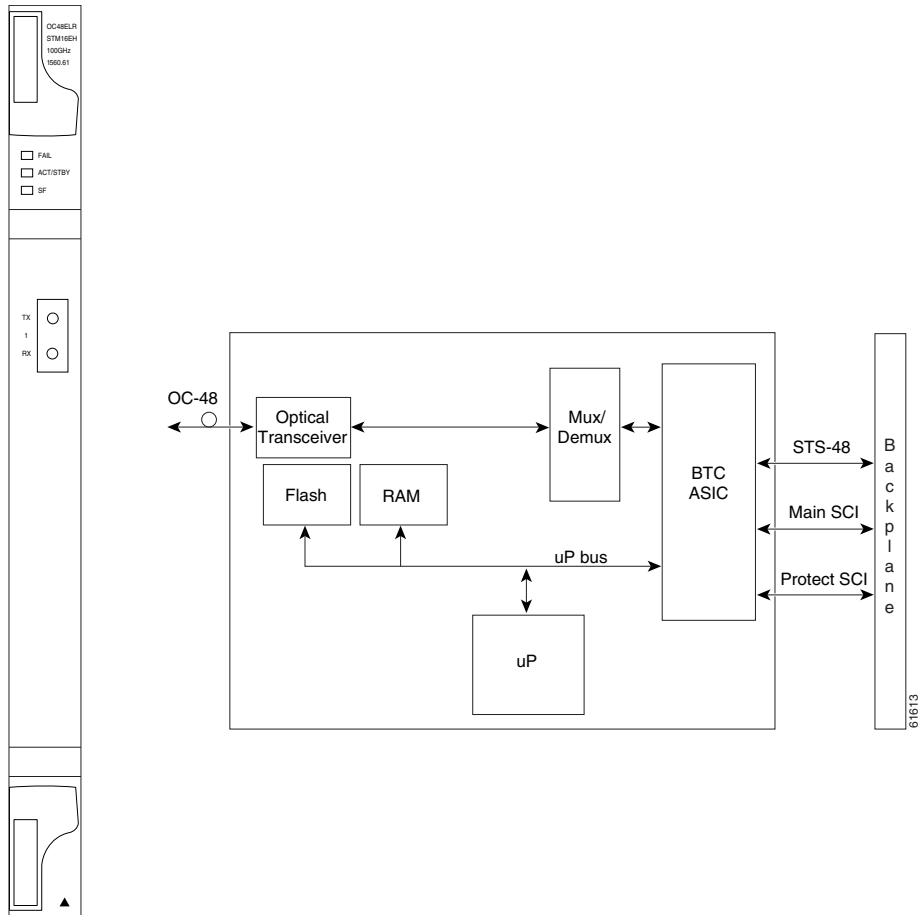

Nineteen of the cards operate in the blue band with spacing of 100 GHz on the ITU grid (1528.77 nm, 1530.33 nm, 1531.12 nm, 1531.90 nm, 1532.68 nm, 1533.47 nm, 1534.25 nm, 1535.04 nm, 1535.82 nm, 1536.61 nm, 1538.19 nm, 1538.98 nm, 1539.77 nm, 1540.56 nm, 1541.35 nm, 1542.14 nm, 1542.94 nm, 1543.73 nm, and 1544.53 nm). ITU spacing conforms to ITU-T G.692 and Telcordia GR-2918-CORE, Issue 2.

The other eighteen cards operate in the red band with spacing of 100 GHz on the ITU grid (1546.12 nm, 1546.92 nm, 1547.72 nm, 1548.51 nm, 1549.32 nm, 1550.12 nm, 1550.92 nm, 1551.72 nm, 1552.52 nm, 1554.13 nm, 1554.94 nm, 1555.75 nm, 1556.55 nm, 1557.36 nm, 1558.17 nm, 1558.98 nm, 1559.79 nm, and 1560.61 nm). These cards are also designed to interoperate with the Cisco ONS 15216 DWDM solution.

You can install the OC48 ELR/STM16 EH 100 GHz cards in Slots 5, 6, 12, and 13 and provision the card as a drop or span card in a two-fiber or four-fiber BLSR, path protection, or ADM (linear) configuration. Each OC48 ELR/STM16 EH 100 GHz card uses extended long-reach optics operating individually within the ITU-T 100-GHz grid. The OC-48 DWDM cards are intended to be used in applications with long unregenerated spans of up to 300 km (186 miles) (with mid-span amplification). These transmission distances are achieved through the use of inexpensive optical amplifiers (flat gain amplifiers) such as Cisco ONS 15216 erbium-doped fiber amplifiers (EDFAs).

Maximum system reach in filterless applications is 26 dB without the use of optical amplifiers or regenerators. However, system reach also depends on the condition of the facilities, the number of splices and connectors, and other performance-affecting factors. When used in combination with

ONS 15216 100-GHz filters, the link budget is reduced by the insertion loss of the filters plus an additional 2-dB power penalty. The wavelength stability of the OC48 ELR/STM16 EH 100 GHz cards is ± 0.12 nm for the life of the product and over the full range of operating temperatures. Each interface contains a transmitter and receiver.

The OC48 ELR/STM16 EH 100 GHz cards detect LOS, LOF, LOP, and AIS-L conditions. The cards also count section and line BIP errors.

4.12.1 OC48 ELR 100 GHz Card-Level Indicators

Table 4-13 lists the three card-level LEDs on the OC48 ELR/STM16 EH 100 GHz cards.

Table 4-13 OC48 ELR/STM16 EH 100 GHz Card-Level Indicators

Card-Level Indicators	Description
Red FAIL LED	The red FAIL LED indicates that the card's processor is not ready. Replace the card if the red FAIL LED persists.
Green/Amber ACT LED	The green ACT LED indicates that the card is carrying traffic or is traffic-ready. The amber ACT LED indicates that the card is part of an active ring switch (BLSR).
Amber SF LED	The amber SF LED indicates a signal failure or condition such as LOS, LOF, or high BERs on the card's port. The amber SF LED is also on if the transmit and receive fibers are incorrectly connected. If the fibers are properly connected, the light turns off.

4.12.2 OC48 ELR 100 GHz Port-Level Indicators

You can find the status of the OC48 ELR/STM16 EH 100 GHz card ports by using the LCD screen on the ONS 15454 fan-tray assembly. Use the LCD to quickly view the status of any port or card slot; the screen displays the number and severity of alarms for a given port or slot.

4.13 OC48 ELR 200 GHz Cards



Note

For hardware specifications, see the “A.6.12 OC48 ELR 200 GHz Card Specifications” section on page A-36. See Table 4-2 on page 4-4 for optical card compatibility.

Eighteen distinct OC48 ELR 200 GHz cards provide the ONS 15454 DWDM channel plan. Each OC48 ELR 200 GHz card provides one SONET OC-48 port that is compliant with Telcordia GR-253-CORE. The port operates at 2.49 Gbps over a single-mode fiber span. The card carries VT, concatenated (STS-1), or nonconcatenated (STS-3c, STS-6c, STS-12c, or STS-48c) payloads.



Warning

The laser is on when the optical card is booted. The port does not have to be in service for the laser to be on.

Figure 4-12 shows the OC48 ELR 200 GHz faceplate and a block diagram of the card.

Figure 4-12 OC48 ELR 200 GHz Faceplate and Block Diagram

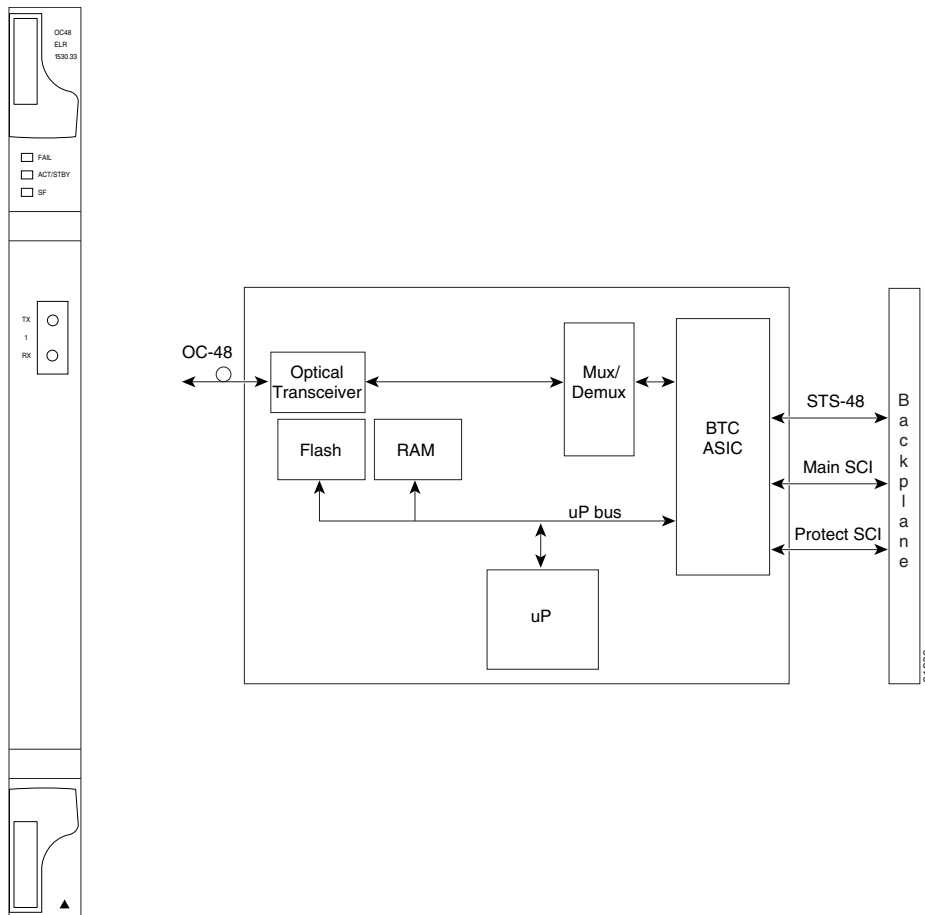

Nine of the cards operate in the blue band with spacing of 200 GHz on the ITU grid (1530.33 nm, 1531.90 nm, 1533.47 nm, 1535.04 nm, 1536.61 nm, 1538.19 nm, 1539.77 nm, 1541.35 nm, and 1542.94 nm).

The other nine cards operate in the red band with spacing of 200 GHz on the ITU grid (1547.72 nm, 1549.32 nm, 1550.92 nm, 1552.52 nm, 1554.13 nm, 1555.75 nm, 1557.36 nm, 1558.98 nm, and 1560.61 nm). These cards are also designed to interoperate with the Cisco ONS 15216 DWDM solution.

You can install the OC48 ELR 200 GHz cards in Slots 5, 6, 12, and 13, and provision the card as a drop or span card in a two-fiber or four-fiber BLSR, path protection, or ADM (linear) configuration. Each OC48 ELR 200 GHz card uses extended long-reach optics operating individually within the ITU-T 200-GHz grid. The OC48 ELR 200 GHz cards are intended to be used in applications with long unregenerated spans of up to 200 km (124 miles) (with mid-span amplification). These transmission distances are achieved through the use of inexpensive optical amplifiers (flat gain amplifiers) such as EDFAs. Using collocated amplification, distances up to 200 km (124 miles) can be achieved for a single channel, 160 km (99 miles) for 8 channels.

Maximum system reach in filterless applications is 24 dB or approximately 80 km (50 miles) without the use of optical amplifiers or regenerators. However, system reach also depends on the condition of the facilities, the number of splices and connectors, and other performance-affecting factors. The OC48 ELR DWDM cards feature wavelength stability of ± 0.25 nm. Each interface contains a transmitter and receiver.

The OC48 ELR 200 GHz cards support extended long-reach applications in conjunction with optical amplification. Using electro-absorption technology, the OC48 DWDM cards provide a solution at the lower extended long-reach distances.

The OC48 ELR 200 GHz interface features a 1550-nm laser and contains a transmit and receive connector (labeled) on the card faceplate. The card uses SC connectors and supports 1+1 unidirectional and bidirectional protection switching.

The OC48 ELR 200 GHz cards detect LOS, LOF, LOP, AIS-L, and RDI-L conditions. The cards also count section and line BIP errors. To enable APS, the OC48 ELR 200 GHz cards extract the K1 and K2 bytes from the SONET overhead. The DCC bytes are forwarded to the TCC2/TCC2P card; the TCC2/TCC2P terminates the DCC/GCC.

4.13.1 OC48 ELR 200 GHz Card-Level Indicators

Table 4-14 describes the three card-level LEDs on the OC48 ELR 200 GHz cards.

Table 4-14 OC48 ELR 200 GHz Card-Level Indicators

Card-Level Indicators	Description
Red FAIL LED	The red FAIL LED indicates that the card's processor is not ready. Replace the card if the red FAIL LED persists.
Green/Amber ACT LED	The green ACT LED indicates that the card is carrying traffic or is traffic-ready. The amber ACT LED indicates that the card is part of an active ring switch (BLSR).
Amber SF LED	The amber SF LED indicates a signal failure or condition such as LOS, LOF, or high BERs on the card's port. The amber SF LED is also on if the transmit and receive fibers are incorrectly connected. If the fibers are properly connected, the light turns off.

4.13.2 OC48 ELR 200 GHz Port-Level Indicators

You can find the status of the OC48 ELR 200 GHz card ports by using the LCD screen on the ONS 15454 fan-tray assembly. Use the LCD to quickly view the status of any port or card slot; the screen displays the number and severity of alarms for a given port or slot.

4.14 OC192 SR/STM64 IO 1310 Card



Note

For hardware specifications, see the “[A.6.13 OC192 SR/STM64 IO 1310 Card Specifications](#)” section on page A-37. See [Table 4-2 on page 4-4](#) for optical card compatibility.

The OC192 SR/STM64 IO 1310 card provides one intra-office haul SONET/SDH OC-192 port in the 1310-nm wavelength range, compliant with ITU-T G.707, ITU-T G.691, ITU-T G.957, and Telcordia GR-253-CORE. The port operates at 9.95328 Gbps over unamplified distances up to 2 km (1.24 miles). The card supports VT, nonconcatenated (STS-1), or concatenated payloads.

**Warning**

The laser is on when the optical card is booted. The port does not have to be in service for the laser to be on.

Figure 4-13 shows the OC192 SR/STM64 IO 1310 faceplate and block diagram.

Figure 4-13 OC192 SR/STM64 IO 1310 Faceplate and Block Diagram

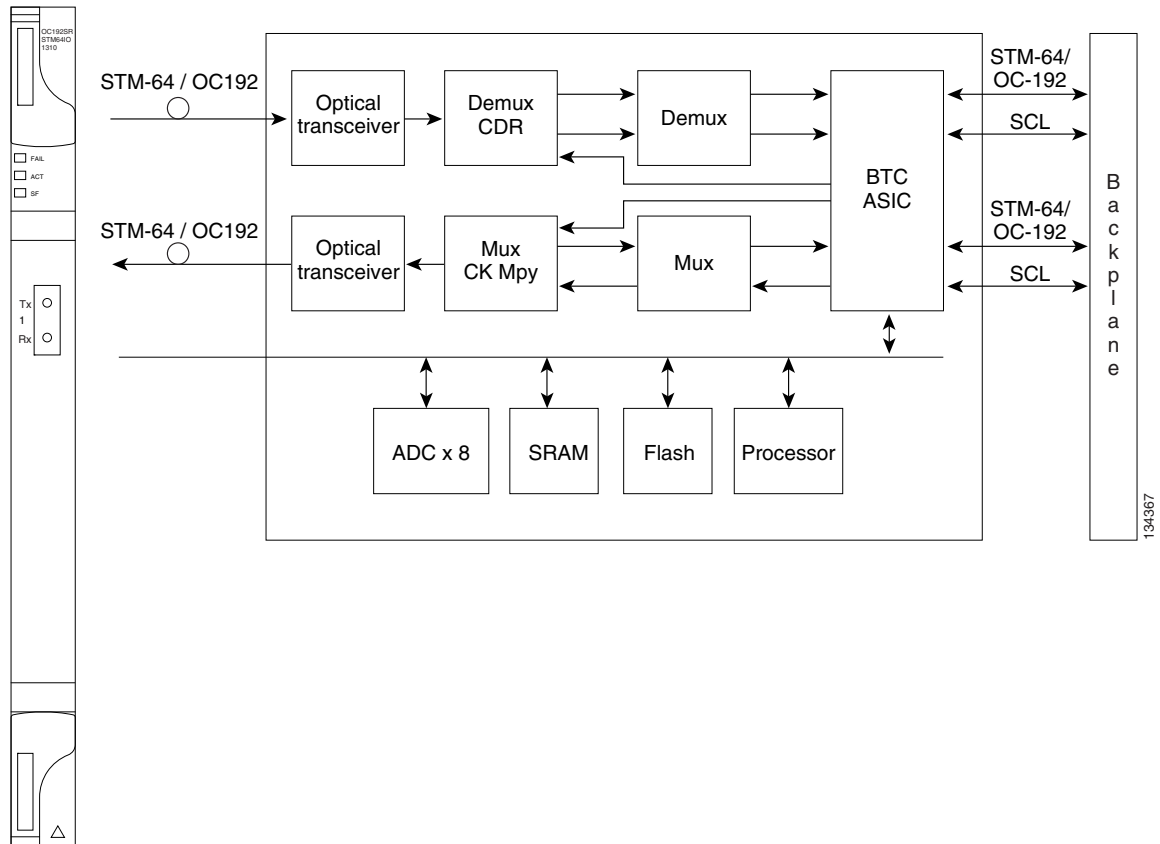

You can install OC192 SR/STM64 IO 1310 cards in Slot 5, 6, 12, or 13. You can provision this card as part of a BLSR, a path protection, a linear configuration, or as a regenerator for longer span reaches.

The OC192 SR/STM64 IO 1310 port features a 1310-nm laser and contains a transmit and receive connector (labeled) on the card faceplate. The card uses a dual SC connector for optical cable termination. The card supports 1+1 unidirectional and bidirectional facility protection. It also supports 1:1 protection in four-fiber BLSR applications where both span switching and ring switching might occur.

The OC192 SR/STM64 IO 1310 card detects SF, LOS, or LOF conditions on the optical facility. Refer to the *Cisco ONS 15454 Troubleshooting Guide* for a description of these conditions. The card also counts section and line BIP errors from B1 and B2 byte registers in the section and line overhead.

4.14.1 OC192 SR/STM64 IO 1310 Card-Level Indicators

Table 4-15 describes the three card-level LEDs on the OC192 SR/STM64 IO 1310 card.

Table 4-15 OC192 SR/STM64 IO 1310 Card-Level Indicators

Card-Level LED	Description
Red FAIL LED	The red FAIL LED indicates that the card's processor is not ready. This LED is on during reset. The FAIL LED flashes during the boot process. Replace the card if the red FAIL LED persists.
ACT/STBY LED Green (Active) Amber (Standby)	If the ACT/STBY LED is green, the card is operational and ready to carry traffic. The amber ACT LED indicates that the card is in standby mode or is part of an active ring switch (BLSR).
Amber SF LED	The amber SF LED indicates a signal failure or condition such as LOS, LOF, or high BERs on one or more of the card's ports. The amber SF LED is also on if the transmit and receive fibers are incorrectly connected. If the fibers are properly connected and the link is working, the light turns off.

4.14.2 OC192 SR/STM64 IO 1310 Port-Level Indicators

You can find the status of the OC192 SR/STM64 IO 1310 card ports by using the LCD screen on the ONS 15454 fan-tray assembly. Use the LCD to view the status of any port or card slot; the screen displays the number and severity of alarms for a given port or slot. Refer to the *Cisco ONS 15454 Troubleshooting Guide* for a complete description of the alarm messages.

4.15 OC192 IR/STM64 SH 1550 Card



Note

For hardware specifications, see the “[A.6.14 OC192 IR/STM64 SH 1550 Card Specifications](#)” section on page A-38. See [Table 4-2 on page 4-4](#) for optical card compatibility.

The OC192 IR/STM64 SH 1550 card provides one intermediate reach SONET/SDH OC-192 port in the 1550-nm wavelength range, compliant with ITU-T G.707, ITU-T G.691, ITU-T G.957, and Telcordia GR-253-CORE. The port operates at 9.95328 Gbps over unamplified distances up to 40 km (25 miles) with SMF-28 fiber limited by loss and/or dispersion. The card supports VT, nonconcatenated (STS-1), or concatenated payloads.



Warning

The laser is on when the optical card is booted. The port does not have to be in service for the laser to be on.

[Figure 4-14](#) shows the OC192 IR/STM64 SH 1550 faceplate and block diagram.

Figure 4-14 OC192 IR/STM64 SH 1550 Faceplate and Block Diagram

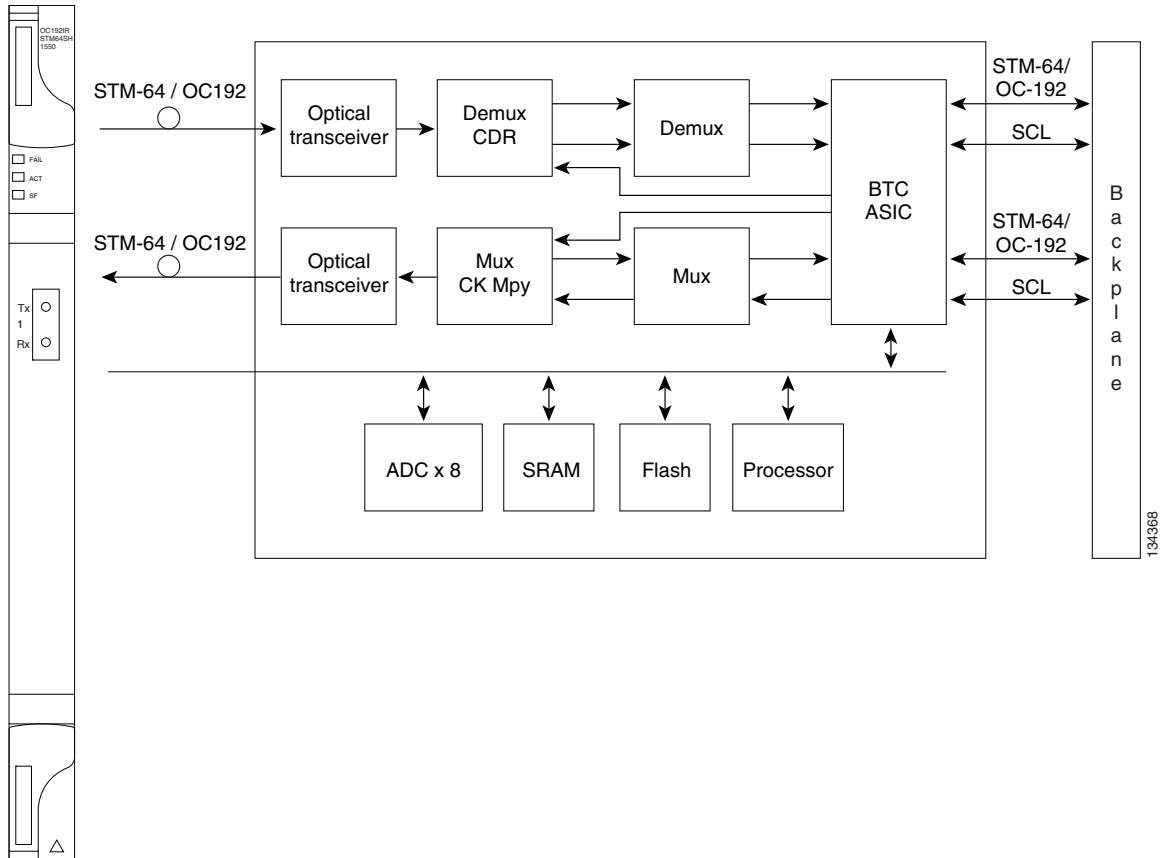
**Note**

You must use a 3 to 15 dB fiber attenuator (5 dB recommended) when working with the OC192 IR/STM64 SH 1550 card in a loopback. Do not use fiber loopbacks with the OC192 IR/STM64 SH 1550 card. Using fiber loopbacks can cause irreparable damage to the card.

You can install OC192 IR/STM64 SH 1550 cards in Slot 5, 6, 12, or 13. You can provision this card as part of a BLSR, path protection, or linear configuration, or also as a regenerator for longer span reaches.

The OC192 IR/STM64 SH 1550 port features a 1550-nm laser and contains a transmit and receive connector (labeled) on the card faceplate. The card uses a dual SC connector for optical cable termination. The card supports 1+1 unidirectional and bidirectional facility protection. It also supports 1:1 protection in four-fiber BLSR applications where both span switching and ring switching might occur.

The OC192 IR/STM64 SH 1550 card detects SF, LOS, or LOF conditions on the optical facility. Refer to the *Cisco ONS 15454 Troubleshooting Guide* for a description of these conditions. The card also counts section and line BIP errors from B1 and B2 byte registers in the section and line overhead.

4.15.1 OC192 IR/STM64 SH 1550 Card-Level Indicators

Table 4-16 describes the three card-level LEDs on the OC192 IR/STM64 SH 1550 card.

Table 4-16 OC192 IR/STM64 SH 1550 Card-Level Indicators

Card-Level LED	Description
Red FAIL LED	The red FAIL LED indicates that the card's processor is not ready. This LED is on during reset. The FAIL LED flashes during the boot process. Replace the card if the red FAIL LED persists.
ACT/STBY LED Green (Active) Amber (Standby)	If the ACT/STBY LED is green, the card is operational and ready to carry traffic. If the ACT/STBY LED is amber, the card is operational and in standby (protect) mode or is part of an active ring switch (BLSR).
Amber SF LED	The amber SF LED indicates a signal failure or condition such as LOS, LOF, or high BERs on one or more of the card's ports. The amber SF LED is also on if the transmit and receive fibers are incorrectly connected. If the fibers are properly connected and the link is working, the light turns off.

4.15.2 OC192 IR/STM64 SH 1550 Port-Level Indicators

You can find the status of the OC192 IR/STM64 SH 1550 card ports by using the LCD screen on the ONS 15454 fan-tray assembly. Use the LCD to view the status of any port or card slot; the screen displays the number and severity of alarms for a given port or slot. Refer to the *Cisco ONS 15454 Troubleshooting Guide* for a complete description of the alarm messages.

4.16 OC192 LR/STM64 LH 1550 Card

Note

For hardware specifications, see the “[A.6.15 OC192 LR/STM64 LH 1550 Card Specifications](#)” section on page A-39. See [Table 4-2 on page 4-4](#) for optical card compatibility.

Note

Any new features that are available as part of this software release are not enabled for this card.

The OC192 LR/STM64 LH 1550 card provides one long-range SONET/SDH OC-192 port compliant with ITU-T G.707, ITU-T G.691, ITU-T G.957, and Telcordia GR-253-CORE (except minimum and maximum transmit power, and minimum receive power). The card port operates at 9.95328 Gbps over unamplified distances up to 80 km (50 miles) with different types of fiber such as C-SMF or dispersion compensated fiber limited by loss and/or dispersion. The card supports VT, nonconcatenated (STS-1), or concatenated payloads.

There are two versions of the OC192 LR/STM64 LH 1550. The earliest version has the product ID 15454-OC192LR1550, and the latest card's product ID is 15454-OC192-LR2. These cards have slight specification differences that are noted throughout this description.

Note

You can differentiate this OC-192/STM-64 card (15454-OC192-LR2, 15454E-L64.2-1) from the OC-192/STM-64 card with the product ID 15454-OC192LR1550 by looking at the faceplate. This card does not have a laser on/off switch.

Warning

The laser is on when the optical card is booted. The port does not have to be in service for the laser to be on.

Figure 4-15 shows the OC192 LR/STM64 LH 1550 (15454-OC192LR1550) faceplate and a block diagram of the card.

Figure 4-15 OC192 LR/STM64 LH 1550 (15454-OC192LR1550) Faceplate and Block Diagram

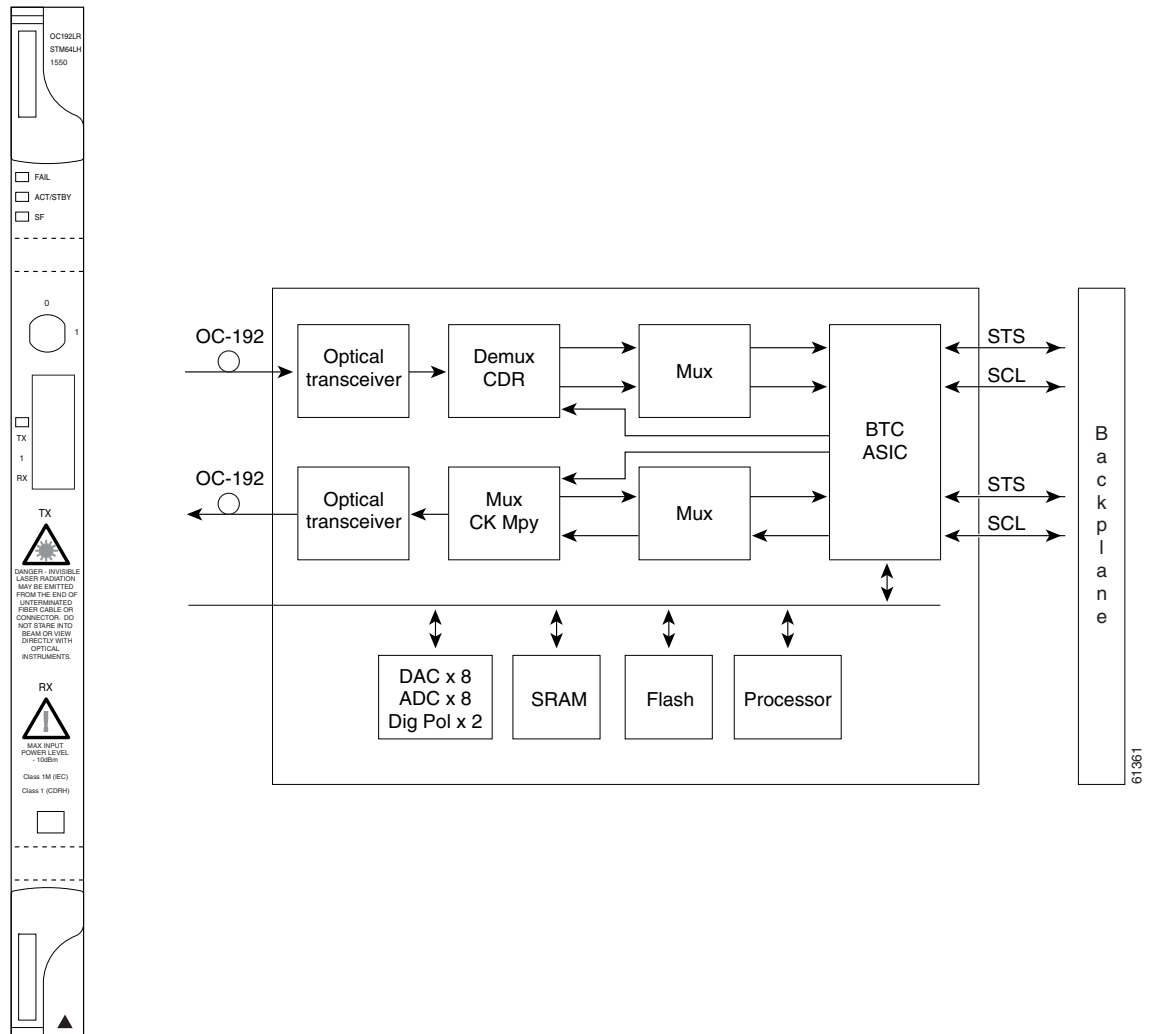

Figure 4-16 shows an enlarged view of the faceplate warning for 15454-OC192-LR2.

Figure 4-16 Enlarged Section of the OC192 LR/STM64 LH 1550 (15454-OC192LR1550) Faceplate

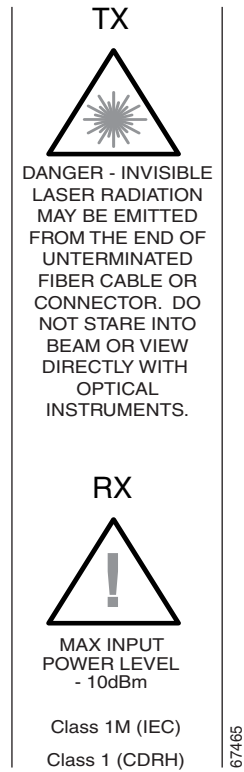

Figure 4-17 shows the OC192 LR/STM64 LH 1550 (15454-OC192-LR2) faceplate and a block diagram of the card.

Figure 4-17 OC192 LR/STM64 LH 1550 (15454-OC192-LR2) Faceplate and Block Diagram

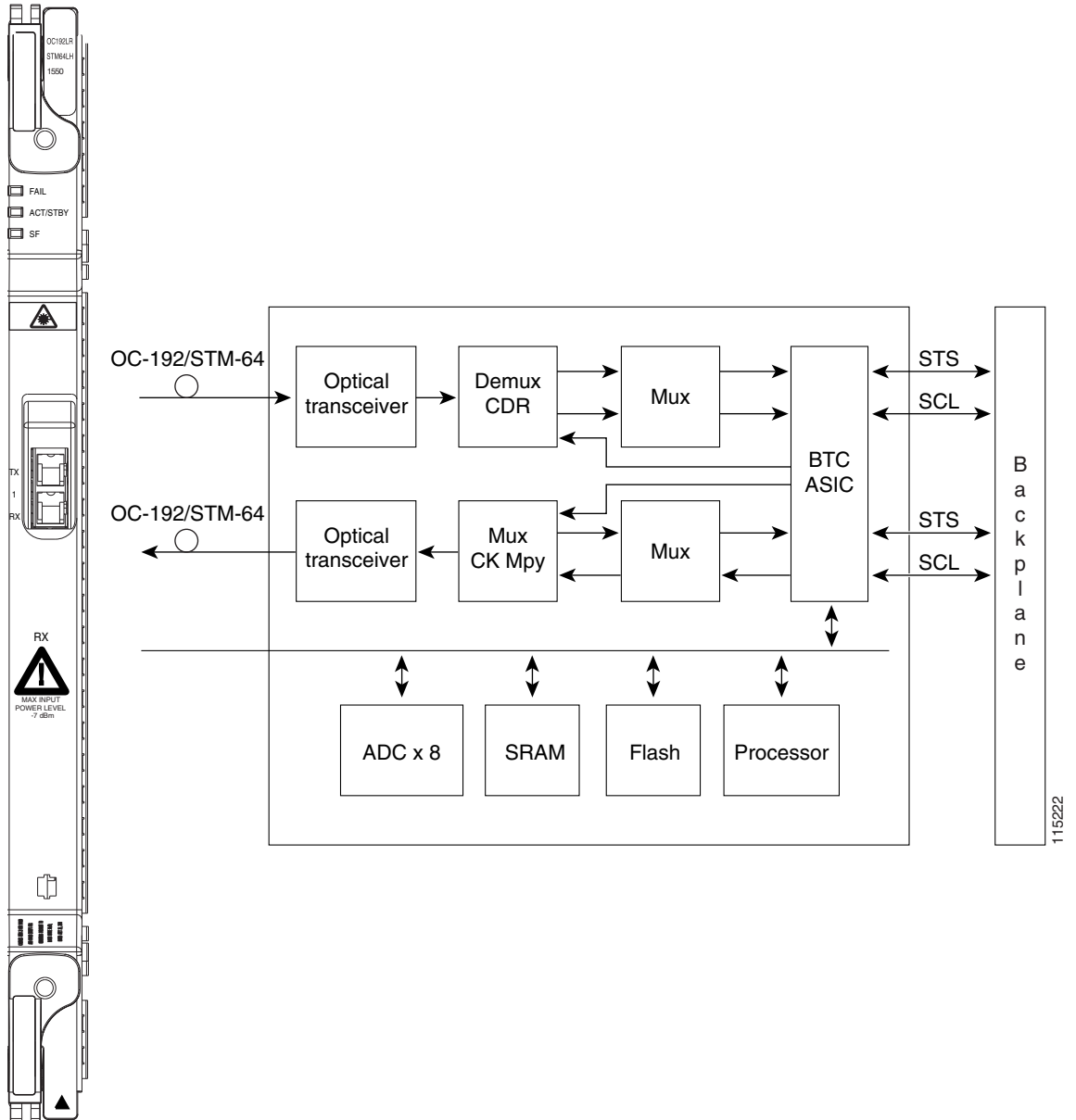
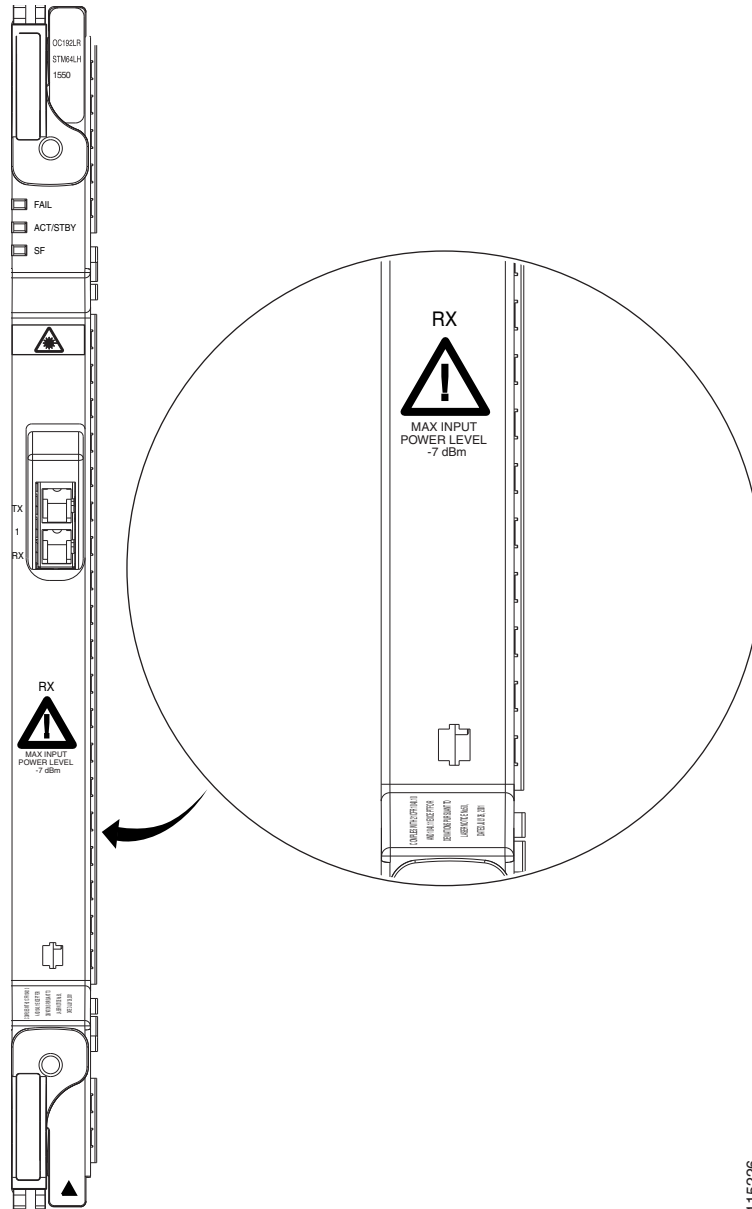

Figure 4-18 shows an enlarged view of the faceplate warning on 15454-OC192LR1550.

Figure 4-18 Enlarged Section of the OC192 LR/STM64 LH 1550 (15454-OC192-LR2) Faceplate



115226



Caution

You must use a 19 to 24 dB (14 to 28 dB for 15454-OC192-LR2) (20 dB recommended) fiber attenuator when connecting a fiber loopback to an OC192 LR/STM64 LH 1550 card. Never connect a direct fiber loopback. Using fiber loopbacks causes irreparable damage to the card. A transmit-to-receive (Tx-to-Rx) connection that is not attenuated damages the receiver.

You can install OC192 LR/STM64 LH 1550 cards in Slots 5, 6, 12, and 13 and provision the card as a drop or span card in a two-fiber or four-fiber BLSR, path protection, ADM (linear) configuration, or as a regenerator for longer span reaches.

The card port features a 1550-nm laser and contains a transmit and receive connector (labeled) on the card faceplate. The card uses a dual SC connector for optical cable termination. The card supports 1+1 unidirectional and bidirectional facility protection. It also supports 1:1 protection in four-fiber BLSR applications where both span switching and ring switching might occur.

The OC192 LR/STM64 LH 1550 card detects SF, LOS, or LOF conditions on the optical facility. The card also counts section and line BIT errors from B1 and B2 byte registers in the section and line overhead.

4.16.1 OC192 LR/STM64 LH 1550 Card-Level Indicators

Table 4-17 describes the three card-level LEDs on the OC192 LR/STM64 LH 1550 card.

Table 4-17 OC192 LR/STM64 LH 1550 Card-Level Indicators

Card-Level Indicators	Description
Red FAIL LED	The red FAIL LED indicates that the card's processor is not ready. Replace the card if the red FAIL LED persists.
ACT/STBY LED Green (Active) Amber (Standby)	If the ACT/STBY LED is green, the card is operational and ready to carry traffic. If the ACT/STBY LED is amber, the card is operational and in standby (protect) mode or is part of an active ring switch (BLSR).
Amber SF LED	The amber SF LED indicates a signal failure or condition such as LOS, LOF, or high BERs on the card's port. The amber SF LED is also on if the transmit and receive fibers are incorrectly connected. If the fibers are properly connected, the light turns off.

4.16.2 OC192 LR/STM64 LH 1550 Port-Level Indicators

You can find the status of the OC192 LR/STM64 LH 1550 card port by using the LCD screen on the ONS 15454 fan-tray assembly. Use the LCD to view the status of the port or card slot; the screen displays the number and severity of alarms for a given port or slot.



Note

The optical output power of the OC192 LR/STM64 LH 1550 (+4 dBm to +7 dBm) is 6 dB lower than in L-64.2b of the 10/2000 prepublished unedited version of ITU-T G.691 (+10 dBm to +13 dBm). However, the total attenuation range of the optical path, 22 to 16 dB, is maintained by the optical receiver sensitivity range of the OC192 LR/STM64 LH 1550 (-7 dBm to -24 dBm). This sensitivity range outperforms the specification in L-64.2b of the 10/2000 prepublished unedited version of ITU-T G.691. The resulting link budget of the card is 26 dBm.

4.17 OC192 LR/STM64 LH ITU 15xx.xx Card



Note

For hardware specifications, see the “[A.6.16 OC192 LR/STM64 LH ITU 15xx.xx Card Specifications](#)” section on page A-40. See [Table 4-2 on page 4-4](#) for optical card compatibility.

Sixteen distinct OC-192/STM-64 ITU 100 GHz DWDM cards comprise the ONS 15454 DWDM channel plan. Each OC192 LR/STM64 LH ITU 15xx.xx card provides one long-reach STM-64/OC-192 port per card, compliant with ITU-T G.707, ITU-T G.957, and Telcordia GR-253-CORE (except minimum and maximum transmit power, and minimum receive power). The port operates at 9.95328 Gbps over unamplified distances up to 60 km (37 miles) with different types of fiber such as C-SMF or dispersion compensated fiber limited by loss and/or dispersion.

**Note**

Longer distances are possible in an amplified system using dispersion compensation.

**Warning**

The laser is on when the optical card is booted. The port does not have to be in service for the laser to be on.

The card supports VT, nonconcatenated (STS-1), or concatenated payloads. [Figure 4-19](#) shows the OC192 LR/STM64 LH ITU 15xx.xx faceplate.

Figure 4-19 OC192 LR/STM64 LH ITU 15xx.xx Faceplate

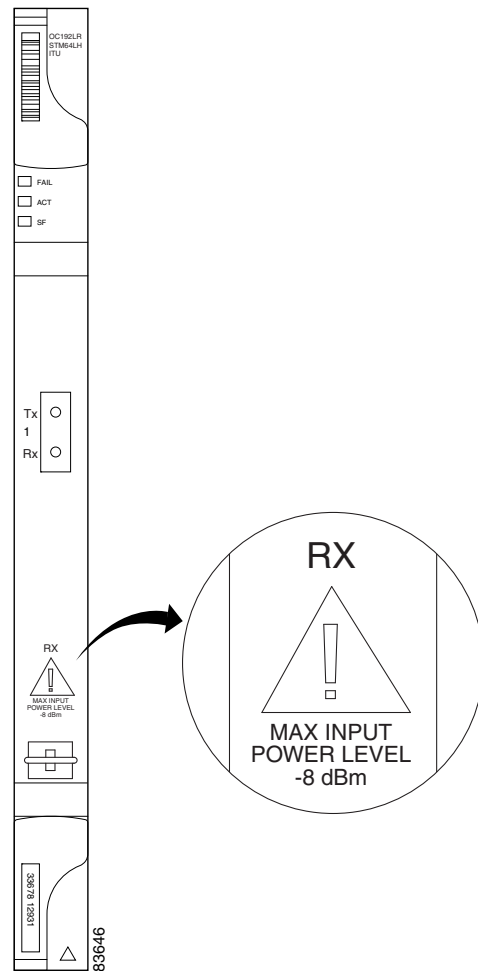

[Figure 4-20](#) shows a block diagram of the OC192 LR/STM64 LH ITU 15xx.xx card.

Figure 4-20 OC192 LR/STM64 LH ITU 15xx.xx Block Diagram

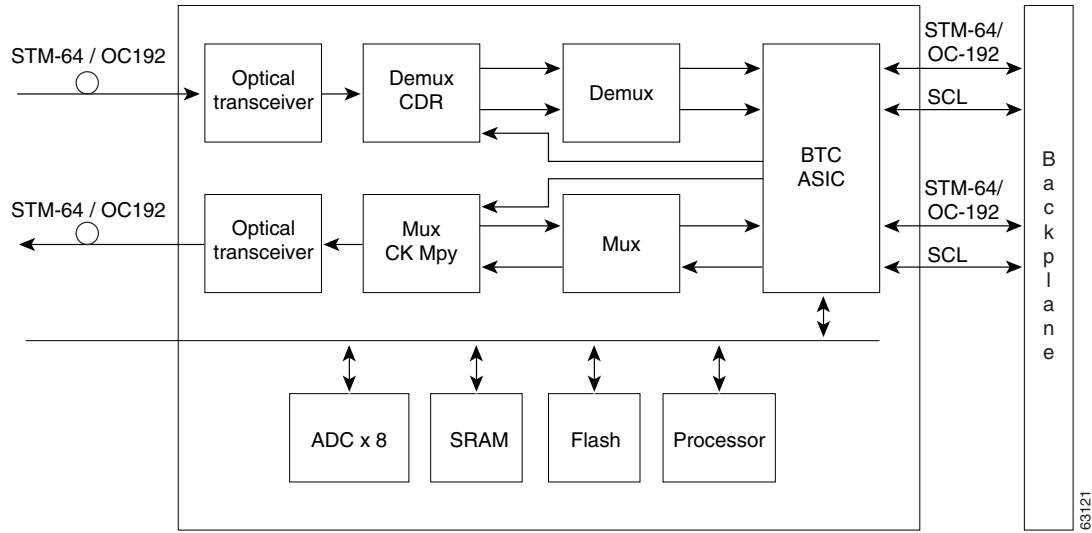
**Note**

You must use a 20-dB fiber attenuator (15 to 25 dB) when working with the OC192 LR/STM64 LH 15xx.xx card in a loopback. Do not use fiber loopbacks with the OC192 LR/STM64 LH 15xx.xx card. Using fiber loopbacks causes irreparable damage to this card.

Eight of the cards operate in the blue band with a spacing of 100 GHz in the ITU grid (1534.25 nm, 1535.04 nm, 1535.82 nm, 1536.61 nm, 1538.19 nm, 1538.98 nm, 1539.77 nm, and 1540.56 nm). The other eight cards operate in the red band with a spacing of 100 GHz in the ITU grid (1550.12 nm, 1550.92 nm, 1551.72 nm, 1552.52 nm, 1554.13 nm, 1554.94 nm, 1555.75 nm, and 1556.55 nm).

You can install OC192 LR/STM64 LH ITU 15xx.xx cards in Slot 5, 6, 12, or 13. You can provision this card as part of an BLSR, path protection, or linear configuration or also as a regenerator for longer span reaches.

The OC192 LR/STM64 LH ITU 15xx.xx port features a laser on a specific wavelength in the 1550-nm range and contains a transmit and receive connector (labeled) on the card faceplate. The card uses a dual SC connector for optical cable termination. The card supports 1+1 unidirectional and bidirectional facility protection. It also supports 1:1 protection in four-fiber BLSR applications where both span switching and ring switching might occur.

The OC192 LR/STM64 LH ITU 15xx.xx card detects SF, LOS, or LOF conditions on the optical facility. Refer to the *Cisco ONS 15454 Troubleshooting Guide* for a description of these conditions. The card also counts section and line BIP errors from B1 and B2 byte registers in the section and line overhead.

4.17.1 OC192 LR/STM64 LH ITU 15xx.xx Card-Level Indicators

Table 4-18 describes the three card-level LEDs on the OC192 LR/STM64 LH ITU 15xx.xx card.

Table 4-18 OC192 LR/STM64 LH ITU 15xx.xx Card-Level Indicators

Card-Level LED	Description
Red FAIL LED	The red FAIL LED indicates that the card's processor is not ready. This LED is on during reset. The FAIL LED flashes during the boot process. Replace the card if the red FAIL LED persists.
ACT/STBY LED Green (Active) Amber (Standby)	If the ACT/STBY LED is green, the card is operational and ready to carry traffic. If the ACT/STBY LED is amber, the card is operational and in standby (protect) mode or is part of an active ring switch (BLSR).
Amber SF LED	The amber SF LED indicates a signal failure or condition such as LOS, LOF, or high BERs on one or more of the card's ports. The amber SF LED is also on if the transmit and receive fibers are incorrectly connected. If the fibers are properly connected and the link is working, the light turns off.

4.17.2 OC192 LR/STM64 LH ITU 15xx.xx Port-Level Indicators

You can find the status of the OC192 LR/STM64 LH ITU 15xx.xx card ports by using the LCD screen on the ONS 15454 fan-tray assembly. Use the LCD to view the status of any port or card slot; the screen displays the number and severity of alarms for a given port or slot. Refer to the *Cisco ONS 15454 Troubleshooting Guide* for a complete description of the alarm messages.

4.18 15454_MRC-12 Multirate Card



Note

For hardware specifications, see the “[A.6.17 15454_MRC-12 Card Specifications](#)” section on [page A-42](#). See [Table 4-2 on page 4-4](#) for optical card compatibility.

The 15454_MRC-12 multirate card provides up to twelve OC-3/STM-1 ports, twelve OC-12/STM-4 ports, or four OC-48/STM-16 ports using small form-factor pluggables (SFPs), in any combination of line rates. All ports are Telcordia GR-253 compliant. The SFP optics can use SR, IR, LR, coarse wavelength division multiplexing (CWDM), and DWDM SFPs to support unrepeated spans. See the “[4.20 Optical Card SFPs and XFPs](#)” section on [page 4-49](#) for more information about SFPs.

The ports operate at up to 2488.320 Mbps over a single-mode fiber. The 15454_MRC-12 card has twelve physical connector adapters with two fibers per connector adapter (Tx and Rx). The card supports VT payloads, STS-1 payloads, and concatenated payloads at STS-3c, STS-6c, STS-9c, STS-12c, STS-18c, STS-24c, STS-36c, or STS-48c signal levels. It is fully interoperable with the ONS 15454 G-Series Ethernet cards.

The 15454_MRC-12 port contains a transmit and receive connector (labeled) on the card faceplate. The card supports 1+1 unidirectional and bidirectional facility protection. It also supports 1+1 protection in four-fiber BLSR applications where both span switching and ring switching might occur. You can provision this card as part of an BLSR, path protection, or 1+1 linear configuration.



Note

Longer distances are possible in an amplified system using dispersion compensation.

[Figure 4-21](#) shows the 15454_MRC-12 faceplate and block diagram.

Figure 4-21 15454_MRC-12 Card Faceplate and Block Diagram

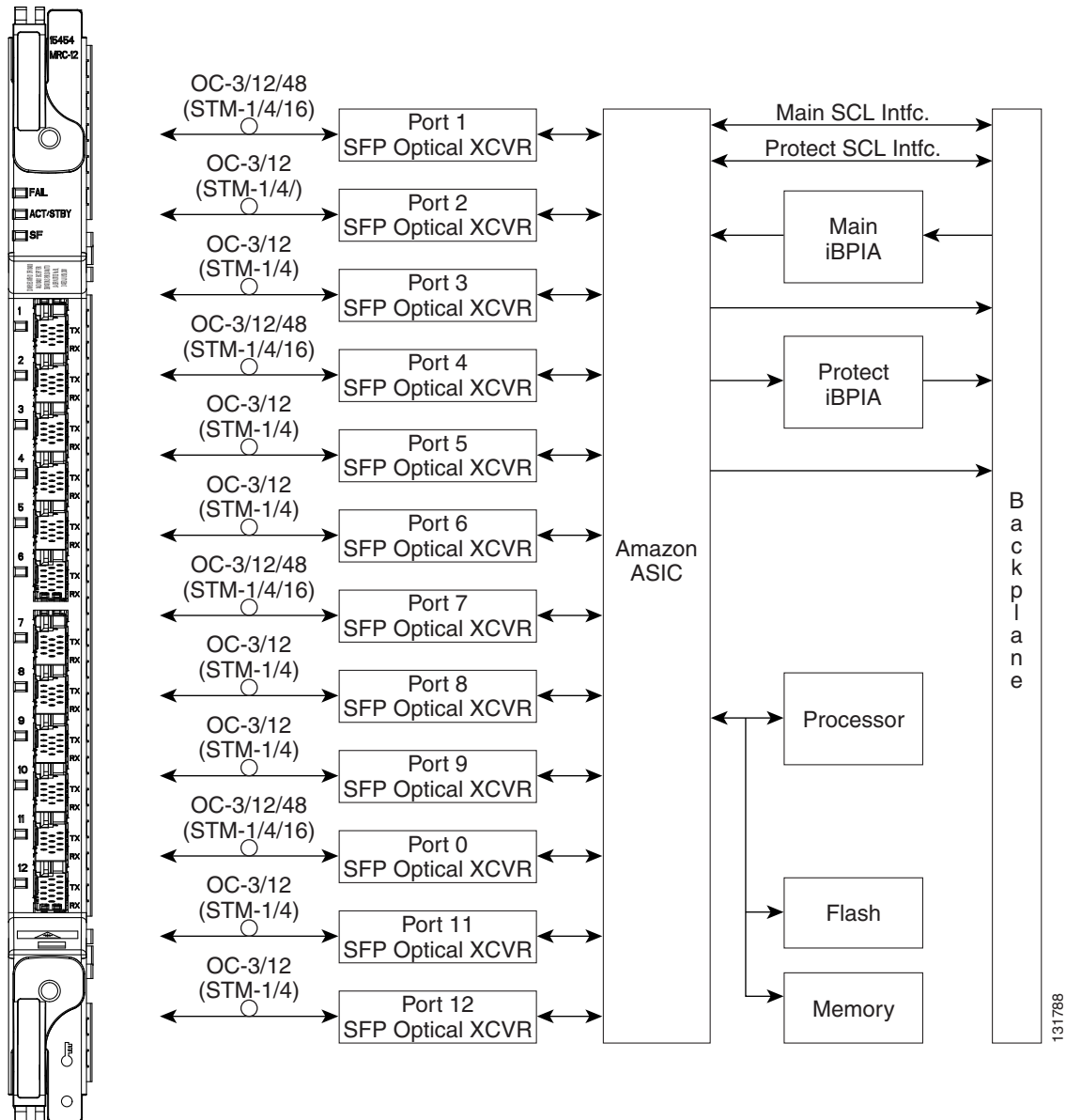

4.18.1 Slot Compatibility by Cross-Connect Card

You can install 15454_MRC-12 cards in Slots 1 through 6 and 12 through 17 with an XCVT, XC10G, or XC-VXC-10G.



Note

The 15454_MRC-12 card supports an errorless software-initiated cross-connect card switch when used in a shelf equipped with XC-VXC-10G and TCC2/TCC2P cards.

The maximum bandwidth of the 15454_MRC-12 card is determined by the cross-connect card, as shown in [Table 4-19](#).

Table 4-19 Maximum Bandwidth by Shelf Slot for the 15454_MRC-12 in Different Cross-Connect Configurations

XC Card Type	Maximum Bandwidth in Slots 1 through 4 and 14 through 17	Maximum Bandwidth in Slots 5, 6, 12, or 13
XCVT	OC-12	OC-48
XC10G/XC-VXC-10G	OC-48	OC-192

4.18.2 Ports and Line Rates

Each port on the 15454_MRC-12 card can be configured as OC-3/STM-1, OC-12/STM-4, or OC-48/STM-16, depending on the available bandwidth and existing provisioned ports. Based on the cross-connect card and slot limitations shown in [Table 4-19](#), the following rules apply for various synchronous transport signal (STS) available bandwidths. ([Table 4-20](#) shows the same information in tabular format.)

- STS-12
 - Port 1 is the only port that is usable as an OC-12. If Port 1 is used as an OC-12, all other ports are disabled.
 - Ports 1, 4, 7, and 10 are the only ports usable as OC-3. If any of these ports is used as an OC-3, Ports 2, 3, 5, 6, 8, 9, 11, and 12 are disabled.
- STS-48
 - Port 1 is the only port usable as an OC-48. If Port 1 is used as an OC-48, all other ports are disabled.
 - Ports 1, 4, 7, and 10 are the only ports usable as OC-12.
 - If Port 4 is used as an OC-12, Ports 2 and 3 are disabled.
 - If Port 7 is used as an OC-12, Ports 5, 6, and 8 are disabled.
 - If Port 10 is used as an OC-12, Ports 9, 11, and 12 are disabled.
 - Any port can be used as an OC-3 as long as all of the above rules are followed.
- STS-192
 - Ports 1, 4, 7, and 10 are the only ports usable as OC-48.
 - If Port 4 is used as an OC-48, Ports 2 and 3 are disabled.
 - If Port 7 is used as an OC-48, Ports 5, 6, and 8 are disabled.
 - If Port 10 is used as an OC-48, Ports 9, 11, and 12 are disabled.
 - If Port 4 is used as an OC-12, Ports 2 and 3 can be used as an OC-12 or OC-3.
 - If Port 7 is used as an OC-12, Ports 5, 6, and 8 can be used as an OC-12 or OC-3.
 - If Port 10 is used as an OC-12, Ports 9, 11, and 12 can be used as an OC-12 or OC-3.
 - If Port 4 is used as an OC-3, Ports 2 and 3 can be used as an OC-3 or OC-12.
 - If Port 7 is used as an OC-3, Ports 5, 6, and 8 can be used as an OC-3 or OC-12.

- If Port 10 is used as an OC-3, Ports 9, 11, and 12 can be used as an OC-3 or OC-12.
- Any port can be used as an OC-12 or OC-3, as long as all of the above rules are followed.

Table 4-20 shows the 15454_MRC-12 port availability and line rate for each port, based on total available bandwidth. To use the table, go to the rows for the bandwidth that you have available, as determined in Table 4-19. Each row indicates what line rate can be provisioned for each port (identified in the MCR-12 Port Number row). The Ports Used column shows the total number of ports that can be used with each bandwidth scheme.

Table 4-20 Line Rate Configurations Per 15454_MRC-12 Port, Based on Available Bandwidth

MRC-12 Port Number	1	2	3	4	5	6	7	8	9	10	11	12	Ports Used	Total STSs
Permitted Rate(s)	OC-3 OC-1 2 OC-4 8	OC-3 OC-1 2	OC-3 OC-1 2	OC-3 OC-12 OC-48	OC-3 OC-1 2	OC-3 OC-1 2	OC-3 OC-12 OC-48	OC-3 OC-1 2	OC-3 OC-1 2	OC-3 OC-12 OC-48	OC-3 OC-1 2	OC-3 OC-1 2	—	—
STS-12 Available Bandwidth	12	—	—	—	—	—	—	—	—	—	—	—	1	12
	3	—	—	3	—	—	3	—	—	3	—	—	4	12
STS-48 Available Bandwidth	3	3	3	3	3	3	3	3	3	3	3	3	12	36
	3	—	—	12	3	3	3	3	3	3	3	3	10	39
	3	—	—	12	—	—	12	—	3	3	3	3	7	39
	3	—	—	12	—	—	12	—	—	12	—	—	4	39
	12	3	3	3	3	3	3	3	3	3	3	3	12	45
	12	—	—	12	3	3	3	3	3	3	3	3	10	48
	12	—	—	12	—	—	12	—	3	3	3	3	7	48
	12	—	—	12	—	—	12	—	—	12	—	—	4	48
	12	3	3	3	—	—	12	—	3	3	3	3	9	45
	12	3	3	3	3	3	3	3	—	12	—	—	9	45
	3	3	3	3	3	3	3	3	—	12	—	—	9	36
	3	3	3	3	—	—	12	—	—	12	—	—	6	36
	48	—	—	—	—	—	—	—	—	—	—	—	1	48
48	3	3	—	12	12	12	12	3	3	3	3	11	114	

Table 4-20 Line Rate Configurations Per 15454_MRC-12 Port, Based on Available Bandwidth (continued)

MRC-12 Port Number	1	2	3	4	5	6	7	8	9	10	11	12	Ports Used	Total STSs	
STS-192 Available Bandwidth (when installing additional SFPs from the top port to the bottom port) ¹	48	3	3	3	3	3	3	3	3	3	3	3	12	81	
	48	12	12	12	3	3	3	3	3	3	3	3	12	108	
	48	12	12	12	12	12	12	12	3	3	3	3	12	144	
	48	12	12	12	12	12	12	12	12	12	12	12	12	180	
	48	3	3	3	12	12	12	12	12	12	12	12	12	153	
	48	3	3	3	3	3	3	3	12	12	12	12	12	117	
	48	—	—	48	3	3	3	3	3	3	3	3	3	10	120
	48	—	—	48	12	12	12	12	3	3	3	3	3	10	156
	48	—	—	48	12	12	12	12	12	12	12	12	12	10	192
	48	—	—	48	—	—	48	—	3	3	3	3	3	7	156
	48	—	—	48	—	—	48	—	12	12	12	12	12	7	192
	48	—	—	48	—	—	48	—	—	48	—	—	—	4	192
	STS-192 Available Bandwidth (when installing additional SFPs from the bottom port to the top port) ¹	3	3	3	3	3	3	3	3	—	48	—	—	9	72
3		3	3	3	12	12	12	12	—	48	—	—	9	108	
3		12	12	12	12	12	12	12	—	48	—	—	9	135	
12		12	12	12	12	12	12	12	—	48	—	—	9	144	
12		12	12	12	3	3	3	3	—	48	—	—	9	108	
12		3	3	3	3	3	3	3	—	48	—	—	9	81	
3		3	3	3	—	—	48	—	—	48	—	—	6	108	
3		12	12	12	—	—	48	—	—	48	—	—	6	135	
12		12	12	12	—	—	48	—	—	48	—	—	6	144	
12		3	3	3	—	—	48	—	—	48	—	—	6	117	
3		—	—	48	—	—	48	—	—	48	—	—	4	147	
12		—	—	48	—	—	48	—	—	48	—	—	4	156	

1. If the MRC-12 card is initially populated with OC-3/12 on all its 12 ports, you can later add OC-48 SFPs on that card from top port to bottom port or from bottom port to top port. The maximum available bandwidth usage is different for these two cases.

4.18.3 15454_MRC-12 Card-Level Indicators

Table 4-21 describes the three card-level LEDs on the 15454_MRC-12 card.

Table 4-21 15454_MRC-12 Card-Level Indicators

Card-Level LED	Description
Red FAIL LED	The red FAIL LED indicates that the card's processor is not ready. This LED is on during reset. The FAIL LED flashes during the boot process. Replace the card if the red FAIL LED persists.
ACT/STBY LED Green (Active) Amber (Standby)	If the ACT/STBY LED is green, the card is operational and ready to carry traffic. If the ACT/STBY LED is amber, the card is operational and in standby (protect) mode or is part of an active ring switch (BLSR).
Amber SF LED	The amber SF LED indicates a signal failure or condition such as LOS, LOF, or high BERs on one or more of the card's ports. The amber SF LED is also on if the transmit and receive fibers are incorrectly connected. If the fibers are properly connected and the link is working, the light turns off.

4.18.4 15454_MRC-12 Port-Level Indicators

Each port has an Rx indicator. The LED flashes green if the port is receiving a signal, and it flashes red if the port is not receiving a signal.

You can also find the status of the 15454_MRC-12 card ports by using the LCD screen on the ONS 15454 fan-tray assembly. Use the LCD to view the status of any port or card slot; the screen displays the number and severity of alarms for a given port or slot. Refer to the *Cisco ONS 15454 Troubleshooting Guide* for a complete description of the alarm messages.

4.19 OC192SR1/STM64IO Short Reach and OC192/STM64 Any Reach Cards



Note

For hardware specifications, see the [“A.6.18 OC192SR1/STM64IO Short Reach Card Specifications”](#) section on page A-43 and the [“A.6.19 OC192/STM64 Any Reach Card Specifications”](#) section on page A-44. See [Table 4-2 on page 4-4](#) for optical card compatibility.

The OC192SR1/STM64IO Short Reach and OC192/STM64 Any Reach cards each provide a single OC-192/STM-64 interface, as follows:

- OC192SR1/STM64IO Short Reach card (SR-1)
- OC192/STM-64 Any Reach card (SR-1, IR-2, and LR-2)

In CTC, these cards are referred to as “OC192-XFP” cards.

The interface operates at 9.952 Gbps over single-mode fiber spans and can be provisioned for both concatenated and nonconcatenated payloads on a per STS-1/VC-4 basis. Specification references can be found for the OC-192/STM-64 interface in ITU-T G.691, ITU-T G.693, and ITU-T G.959.1, and Telcordia GR-253.

The optical interface uses a 10-Gbps form-factor pluggable (XFP) optical transceiver that plugs into a receptacle on the front of the card. The OC192SR1/STM64IO Short Reach card is used only with an SR-1 XFP, while the OC192/STM-64 Any Reach card can be provisioned for use with an SR-1, IR-2, or

LR-2 XFP module. The XFP SR, IR, and LR interfaces each provide one bidirectional OC192/STM64 interface compliant with the recommendations defined by ITU-T G.91. SR-1 is compliant with ITU-T I-64.1, IR-2 is compliant with ITU G.691 S-64.2b, and LR-2 is compliant with ITU G.959.1 P1L1-2D2.

The cards are used only in Slots 5, 6, 12, and 13, and only with 10-Gbps cross-connect cards, such as the XC10G and XC-VXC-10G.

**Note**

The OC192SR1/STM64IO Short Reach and OC192/STM64 Any Reach cards support an errorless software-initiated cross-connect card switch when used in a shelf equipped with XC-VXC-10G and TCC2/TCC2P cards.

[Figure 4-22](#) shows the faceplates and block diagram for the two cards.

Figure 4-22 OC192SR1/STM64IO Short Reach and OC192/STM64 Any Reach Card Faceplates and Block Diagram

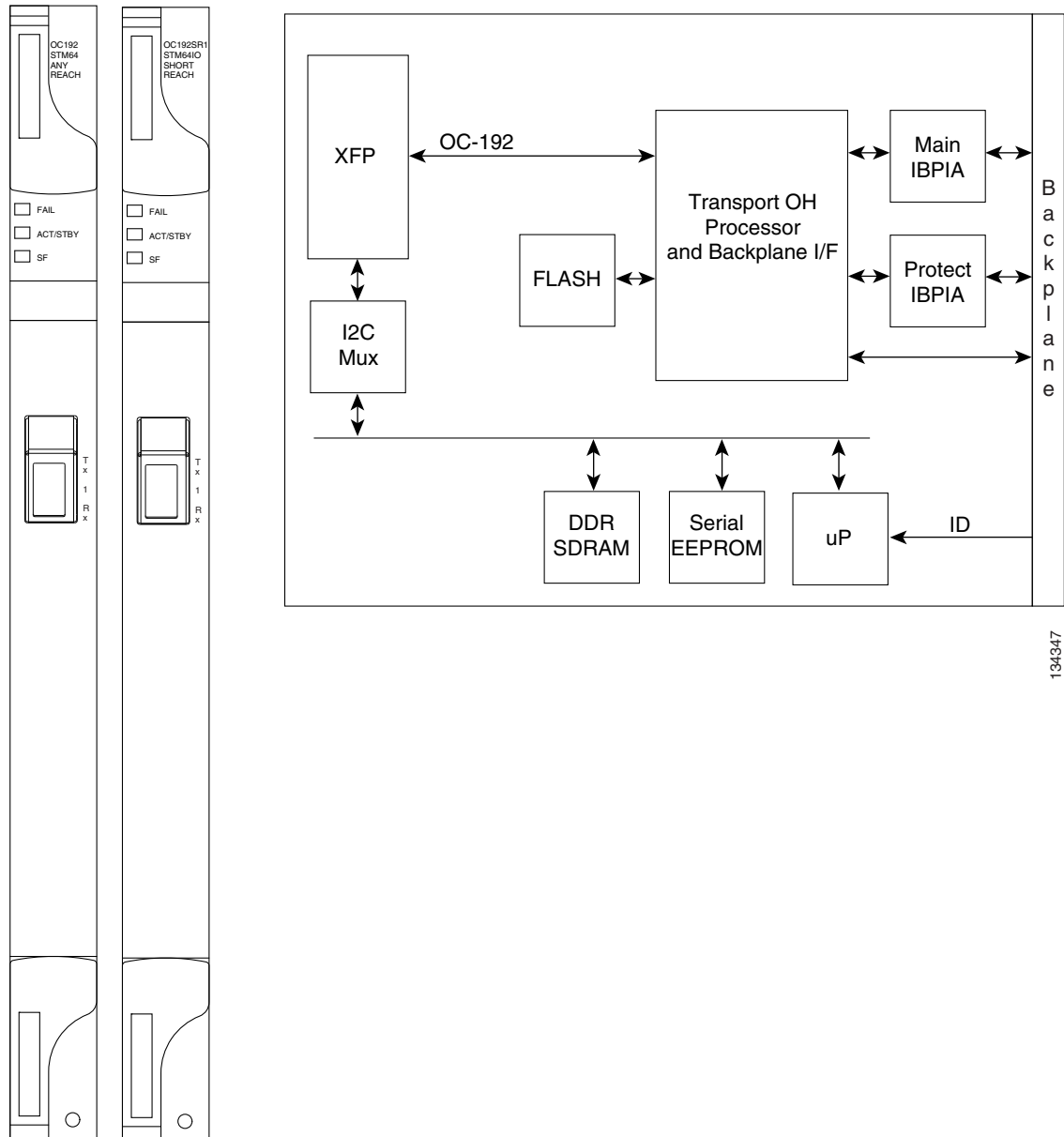

The cards' spans depend on the XFP module that is used:

- A card using the SR-1 XFP is intended to be used in applications requiring 10-Gbps transport with unregenerated spans of up to 2.0 km.
- A card using the IR-2 XFP is intended to be used in applications requiring 10-Gbps transport with unregenerated spans of up to 40 km.
- A card using the LR-2 XFP is intended to be used in applications requiring 10-Gbps transport with unregenerated spans of up to 80 km.

4.19.1 OC192SR1/STM64IO Short Reach and OC192/STM64 Any Reach Card-Level Indicators

Table 4-22 describes the three card-level LEDs on the OC192SR1/STM64IO Short Reach and OC192/STM64 Any Reach cards.

Table 4-22 OC192SR1/STM64IO Short Reach and OC192/STM64 Any Reach Card-Level Indicators

Card-Level LED	Description
Red FAIL LED	The red FAIL LED indicates that the card's processor is not ready. This LED is on during reset. The FAIL LED flashes during the boot process. Replace the card if the red FAIL LED persists.
ACT/STBY LED Green (Active) Amber (Standby)	If the ACT/STBY LED is green, the card is operational and ready to carry traffic. If the ACT/STBY LED is amber, the card is operational and in standby (protect) mode or is part of an active ring switch (BLSR).
Amber SF LED	The amber SF LED indicates a signal failure or condition such as LOS, LOF, or high BERs on one or more of the card's ports. The amber SF LED is also on if the transmit and receive fibers are incorrectly connected. If the fibers are properly connected and the link is working, the light turns off.

4.19.2 OC192SR1/STM64IO Short Reach and OC-192/STM-64 Any Reach Port-Level Indicators

You can find the status of the OC192SR1/STM64IO Short Reach and OC192/STM64 Any Reach card ports by using the LCD screen on the ONS 15454 fan-tray assembly. Use the LCD to view the status of any port or card slot; the screen displays the number and severity of alarms for a given port or slot. Refer to the *Cisco ONS 15454 Troubleshooting Guide* for a complete description of the alarm messages.

4.20 Optical Card SFPs and XFPs

The ONS 15454 optical cards use industry-standard SFPs and XFP modular receptacles.

Currently, the only optical cards that use SFPs and XFPs are the 15454_MRC-12, OC192SR1/STM64IO Short Reach, and OC192/STM64 Any Reach cards.

For all optical cards, the type of SFP or XFP plugged into the card is displayed in CTC and TL1. Cisco offers SFPs and XFPs as separate orderable products.

4.20.1 Compatibility by Card

Table 4-23 lists Cisco ONS 15454 optical cards and their compatible SFPs and XFPs.



Caution

Only use SFPs and XFPs certified for use in Cisco Optical Networking Systems (ONSs). The qualified Cisco SFP and XFP pluggable module's top assembly numbers (TANs) are provided in Table 4-23.

Table 4-23 SFP and XFP Card Compatibility

Card	Compatible SFPs and XFPs (Cisco Product ID)	Cisco Top Assembly Number (TAN) ¹
15454_MRC-12 (ONS 15454 SONET/SDH)	ONS-SI-2G-S1	10-1992-01
	ONS-SI-2G-I1	10-1993-01
	ONS-SI-2G-L1	10-2102-01
	ONS-SI-2G-L2	10-1990-01
	ONS-SC-2G-30.3 through	10-2155-01 through
	ONS-SC-2G-60.6	10-2186-01
	ONS-SI-622-I1	10-1956-01
	ONS-SI-622-L1	10-1958-01
	ONS-SI-622-L2	10-1936-01
	ONS-SE-622-1470 through	10-2004-01 through
	ONS-SE-622-1610	10-2011-01
	ONS-SI-155-I1	10-1938-01
	ONS-SI-155-L1	10-1957-01
	ONS-SI-155-L2	10-1937-01
	ONS_SE-155-1470 through	10-1996-01 through
ONS-SE-155-1610	10-2003-01	
OC192SR1/STM64IO Short Reach (ONS 15454 SONET/SDH) ²	ONS-XC-10G-S1	10-2012-01
OC192/STM64 Any Reach (ONS 15454 SONET/SDH) ²	ONS-XC-10G-S1	10-2012-01
	ONS-XC-10G-I2	10-2193-01
	ONS-XC-10G-L2	10-2194-01

1. The TAN indicated for the pluggables are backward compatible. For example, TAN 10-2307-02 is compatible with 10-2307-01.
2. This card is designated as OC192-XFP in CTC.

4.20.2 SFP Description

SFPs are integrated fiber optic transceivers that provide high-speed serial links from a port or slot to the network. Various latching mechanisms can be utilized on the modules. There is no correlation between the type of latch to the model type (such as SX or LX/LH) or technology type (such as Gigabit Ethernet). See the label on the SFP for technology type and model. Three latch types are available: mylar (Figure 4-23), actuator/button (Figure 4-24), and bail clasp (Figure 4-25).

Figure 4-23 Mylar Tab SFP

Figure 4-24 Actuator/Button SFP**Figure 4-25 Bail Clasp SFP**

SFP dimensions are:

- Height 0.03 in. (8.5 mm)
- Width 0.53 in. (13.4 mm)
- Depth 2.22 in. (56.5 mm)

SFP temperature ranges are:

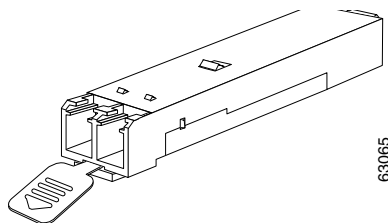
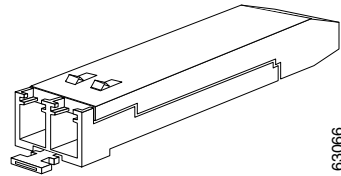
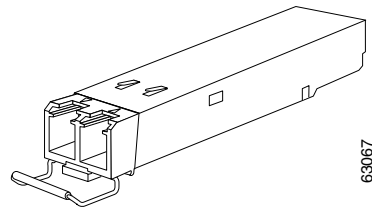
- COM—Commercial operating temperature range: 23 to 158 degrees Fahrenheit (–5 to 70 degrees Celsius)
- EXT—Extended operating temperature range: 23 to 185 degrees Fahrenheit (–5 to 85 degrees Celsius)
- IND—Industrial operating temperature range: –40 to 185 degrees Fahrenheit (–40 to 85 degrees Celsius)

4.20.3 XFP Description

The 10-Gbps 1310-nm and 1550-nm XFP transceivers are integrated fiber optic transceivers that provide high-speed serial links at the following signaling rates: 9.95 Gbps, 10.31 Gbps, and 10.51 Gbps. The XFP integrates the receiver and transmit path. The transmit side recovers and retimes the 10-Gbps serial data and passes it to a laser driver. The laser driver biases and modulates a 1310-nm or 1550-nm distributed feedback (DFB) laser, enabling data transmission over single-mode fiber (SMF) through an LC connector. The receive side recovers and retimes the 10-Gbps optical data stream from a positive-intrinsic-negative (PIN) photodetector, transimpedance amplifier and passes it to an output driver.

The XFP module uses the bail clasp latching mechanism, shown unlatched in [Figure 4-26](#) and latched in [Figure 4-27](#). See the label on the XFP for technology type and model.

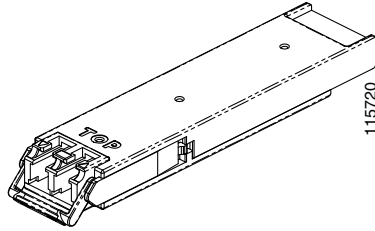
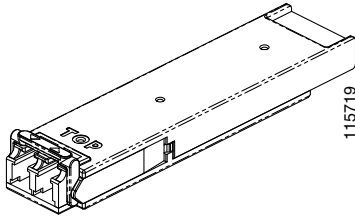
Figure 4-26 Bail Clasp XFP (Unlatched)**Figure 4-27 Bail Clasp XFP (Latched)**

XFP dimensions are:

- Height 0.33 in. (8.5 mm)
- Width 0.72 in. (18.3 mm)
- Depth 3.1 in. (78 mm)

XFP temperature ranges are:

- COM—Commercial operating temperature range: 23 to 158 degrees Fahrenheit (–5 to 70 degrees Celsius)
- EXT—Extended operating temperature range: 23 to 185 degrees Fahrenheit (–5 to 85 degrees Celsius)
- IND—Industrial operating temperature range: –40 to 185 degrees Fahrenheit (–40 to 85 degrees Celsius)

4.20.4 PPM Provisioning

SFPs and XFPs are known as pluggable-port modules (PPMs) in the CTC. Multirate PPMs for the 15454_MRC-12 card can be provisioned for different line rates in CTC. For more information about provisioning PPMs, refer to the *Cisco ONS 15454 Procedure Guide*.



CHAPTER 5

Ethernet Cards



Note

The terms "Unidirectional Path Switched Ring" and "UPSR" may appear in Cisco literature. These terms do not refer to using Cisco ONS 15xxx products in a unidirectional path switched ring configuration. Rather, these terms, as well as "Path Protected Mesh Network" and "PPMN," refer generally to Cisco's path protection feature, which may be used in any topological network configuration. Cisco does not recommend using its path protection feature in any particular topological network configuration.

The Cisco ONS 15454 integrates Ethernet into a SONET platform through the use of Ethernet cards. This chapter describes the E-Series, G-Series, ML-Series, and CE-Series Ethernet cards. For installation and card turn-up procedures, refer to the *Cisco ONS 15454 Procedure Guide*. For ML-Series configuration information, refer to the *Ethernet Card Software Feature and Configuration Guide for the Cisco ONS 15454, Cisco ONS 15454 SDH, and Cisco ONS 15327*.

Chapter topics include:

- [5.1 Ethernet Card Overview, page 5-1](#)
- [5.2 E100T-12 Card, page 5-3](#)
- [5.3 E100T-G Card, page 5-6](#)
- [5.4 E1000-2 Card, page 5-8](#)
- [5.5 E1000-2-G Card, page 5-11](#)
- [5.6 G1000-4 Card, page 5-14](#)
- [5.7 G1K-4 Card, page 5-16](#)
- [5.8 ML100T-12 Card, page 5-19](#)
- [5.9 ML100X-8 Card, page 5-21](#)
- [5.10 ML1000-2 Card, page 5-23](#)
- [5.11 CE-100T-8 Card, page 5-25](#)
- [5.12 CE-1000-4 Card, page 5-28](#)
- [5.13 Ethernet Card GBICs and SFPs, page 5-31](#)

5.1 Ethernet Card Overview

The card overview section summarizes the Ethernet card functions and provides the software compatibility for each card.

**Note**

Each card is marked with a symbol that corresponds to a slot (or slots) on the ONS 15454 shelf assembly. The cards are then installed into slots displaying the same symbols. Refer to the *Cisco ONS 15454 Procedure Guide* for a list of slots and symbols.

5.1.1 Ethernet Cards

Table 5-1 lists the Cisco ONS 15454 Ethernet cards.

Table 5-1 Ethernet Cards for the ONS 15454

Card	Port Description	For Additional Information...
E100T-12	The E100T-12 card provides 12 switched, autosensing, 10/100BaseT Ethernet ports and is compatible with the XCVT card.	See the “5.2 E100T-12 Card” section on page 5-3.
E100T-G	The E100T-G card provides 12 switched, autosensing, 10/100BaseT Ethernet ports and is compatible with the XC10G and XC-VXC-10G cards.	See the “5.3 E100T-G Card” section on page 5-6.
E1000-2	The E1000-2 card provides two IEEE-compliant, 1000-Mbps ports. Gigabit Interface Converters (GBICs) are separate.	See the “5.4 E1000-2 Card” section on page 5-8.
E1000-2-G	The E1000-2-G card provides two IEEE-compliant, 1000-Mbps ports. GBICs are separate. The E1000-2-G card is compatible with the XC10G and XC-VXC-10G cards.	See the “5.5 E1000-2-G Card” section on page 5-11.
G1000-4	The G1000-4 card provides four IEEE-compliant, 1000-Mbps ports. GBICs are separate. The G1000-4 requires the XC10G card.	See the “5.6 G1000-4 Card” section on page 5-14
G1K-4	The G1K-4 card provides four IEEE-compliant, 1000-Mbps ports. GBICs are separate. The G1K-4 card is functionally identical to the G1000-4 card, but can operate with XCVT, XC10G and XC-VXC-10G cross-connect cards.	See the “5.7 G1K-4 Card” section on page 5-16.
M100T-12	The ML100T-12 card provides 12 switched, autosensing, 10/100Base-T Ethernet ports.	See the “5.8 ML100T-12 Card” section on page 5-19.
M100X-8	The ML100X-8 card provides eight switched, 100BaseFX Ethernet ports.	See the “5.9 ML100X-8 Card” section on page 5-21.
M1000-2	The ML1000-2 card provides two IEEE-compliant, 1000-Mbps ports. Small form-factor pluggable (SFP) connectors are separate.	See the “5.10 ML1000-2 Card” section on page 5-23.

Table 5-1 Ethernet Cards for the ONS 15454 (continued)

Card	Port Description	For Additional Information...
CE-100T-8	The CE-100T-8 card provides eight IEEE-compliant, 10/100-Mbps ports. The CE-100T-8 can operate with the XC10G, XC-VXC-10G, or XCVT cross-connect cards.	See the “ 5.11 CE-100T-8 Card ” section on page 5-25.
CE-1000-4	The CE-1000-4 card provides four IEEE-compliant, 1000-Mbps ports. The CE-1000-4 card can operate with the XC10G, XC-VXC-10G, or XCVT cross-connect cards.	See the “ 5.12 CE-1000-4 Card ” section on page 5-28.

5.1.2 Card Compatibility

Table 5-2 lists the CTC software compatibility for each Ethernet card.

Note

“Yes” indicates that this card is fully or partially supported by the indicated software release. Refer to the individual card reference section for more information about software limitations for this card.

Table 5-2 Ethernet Card Software Compatibility

Ethernet Cards	R2.2.1	R2.2.2	R3.0.1	R3.1	R3.2	R3.3	R3.4	R4.0	R4.1	R4.5	R4.6	R4.7	R5.0	R6.0	R7.0
E100T-12	Yes	Yes	Yes	Yes	Yes	Yes	Yes	Yes	Yes	—	Yes	—	Yes	Yes	Yes
E1000-2	Yes	Yes	Yes	Yes	Yes	Yes	Yes	Yes	Yes	—	Yes	—	Yes	Yes	Yes
E100T-G	Yes	Yes	Yes	Yes	Yes	Yes	Yes	Yes	Yes	—	Yes	—	Yes	Yes	Yes
E1000-2-G	Yes	Yes	Yes	Yes	Yes	Yes	Yes	Yes	Yes	—	Yes	—	Yes	Yes	Yes
G1000-4	—	—	—	—	Yes	Yes	Yes	Yes	Yes	—	Yes	—	Yes	Yes	Yes
G1K-4	—	—	—	—	Yes	Yes	Yes	Yes	Yes	—	Yes	—	Yes	Yes	Yes
ML100T-12	—	—	—	—	—	—	—	Yes	Yes	—	Yes	—	Yes	Yes	Yes
ML100X-8	—	—	—	—	—	—	—	—	—	—	—	—	—	Yes	Yes
ML1000-2	—	—	—	—	—	—	—	Yes	Yes	—	Yes	—	Yes	Yes	Yes
CE-100T-8	—	—	—	—	—	—	—	—	—	—	—	—	Yes	Yes	Yes
CE-1000-4	—	—	—	—	—	—	—	—	—	—	—	—	—	—	Yes

5.2 E100T-12 Card



Note

For hardware specifications, see the “[A.7.1 E100T-12 Card Specifications](#)” section on page A-45.

The ONS 15454 uses E100T-12 cards for Ethernet (10 Mbps) and Fast Ethernet (100 Mbps). Each card provides 12 switched, IEEE 802.3-compliant, 10/100BaseT Ethernet ports that can independently detect the speed of an attached device (autosense) and automatically connect at the appropriate speed. The ports

autoconfigure to operate at either half or full duplex and determine whether to enable or disable flow control. You can also configure Ethernet ports manually. Figure 5-1 shows the faceplate and a block diagram of the card.

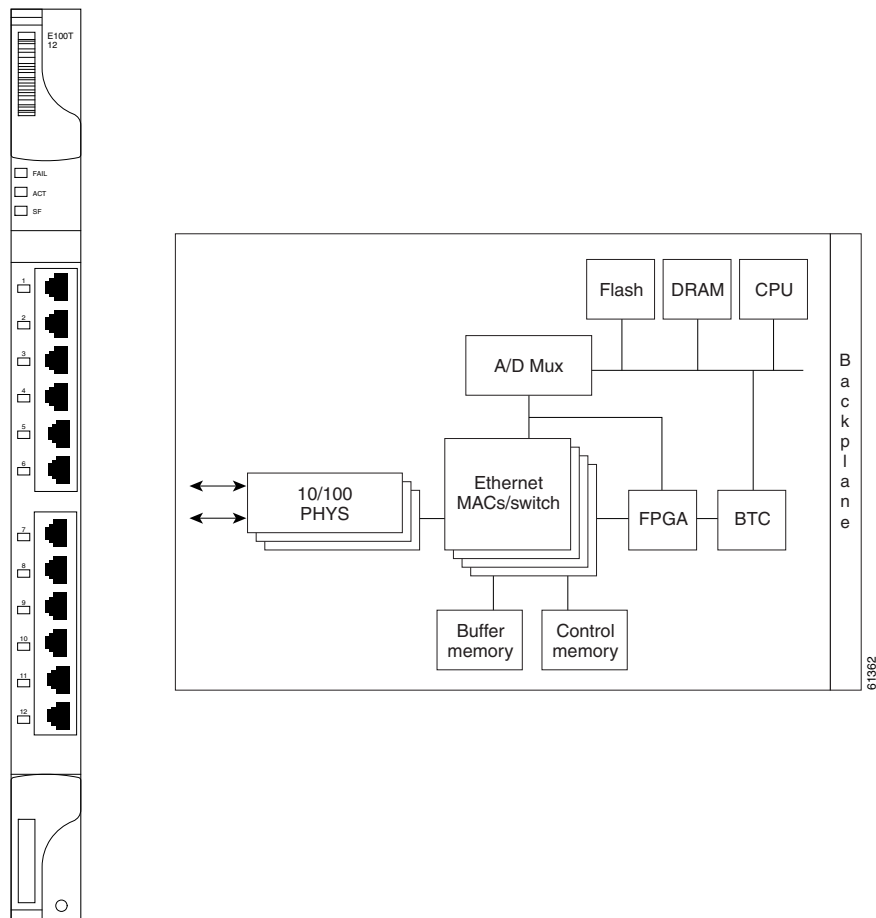
Figure 5-1 E100T-12 Faceplate and Block Diagram



The E100T-12 Ethernet card provides high-throughput, low-latency packet switching of Ethernet traffic across a SONET network while providing a greater degree of reliability through SONET self-healing protection services. This Ethernet capability enables network operators to provide multiple 10/100-Mbps access drops for high-capacity customer LAN interconnects, Internet traffic, and cable modem traffic aggregation. It enables the efficient transport and co-existence of traditional time-division multiplexing (TDM) traffic with packet-switched data traffic.

Each E100T-12 card supports standards-based, wire-speed, Layer 2 Ethernet switching between its Ethernet interfaces. The IEEE 802.1Q tag logically isolates traffic (typically subscribers). IEEE 802.1Q also supports multiple classes of service.

5.2.1 Slot Compatibility

You can install the E100T-12 card in Slots 1 to 6 and 12 to 17. Multiple E-Series Ethernet cards installed in an ONS 15454 can act independently or as a single Ethernet switch. You can create logical SONET ports by provisioning STS channels to the packet switch entity within the ONS 15454. Logical ports can be created with a bandwidth granularity of STS-1. The E100T-12 supports STS-1, STS-3c, STS-6c, and STS-12c circuit sizes.

Note

When making an STS-12c Ethernet circuit, the E-Series cards must be configured as single-card EtherSwitch.

5.2.2 E100T-12 Card-Level Indicators

The E100T-12 card faceplate has two card-level LED indicators, described in [Table 5-3](#).

Table 5-3 E100T-12 Card-Level Indicators

Card-Level Indicators	Description
FAIL LED (Red)	The red FAIL LED indicates that the card processor is not ready or that a catastrophic software failure occurred on the E100T-12 card. As part of the boot sequence, the FAIL LED is on until the software deems the card operational.
ACT LED (Green)	The green ACT LED provides the operational status of the E100T-12. If the ACT LED is green, it indicates that the E100T-12 card is active and the software is operational.
SF LED	Not used.

5.2.3 E100T-12 Port-Level Indicators

The E100T-12 card has 12 pairs of LEDs (one pair for each port) to indicate port conditions. [Table 5-4](#) lists the port-level indicators. You can find the status of the E100T-12 card port using the LCD on the ONS 15454 fan-tray assembly. Use the LCD to view the status of any port or card slot; the screen displays the number and severity of alarms for a given port or slot.

Table 5-4 E100T-12 Port-Level Indicators

LED State	Description
Amber	The port is active (transmitting and receiving data).
Solid green	The link is established.
Off	The connection is inactive, or traffic is unidirectional.

5.2.4 Cross-Connect Compatibility

The E100T-12 card is compatible with the XCVT card. Do not use the E100T-12 card with the XC10G and XC-VXC-10G cards.

5.3 E100T-G Card



Note

For hardware specifications, see the “A.7.2 E100T-G Card Specifications” section on page A-45.

The ONS 15454 uses E100T-G cards for Ethernet (10 Mbps) and Fast Ethernet (100 Mbps). Each card provides 12 switched, IEEE 802.3-compliant, 10/100BaseT Ethernet ports that can independently detect the speed of an attached device (autosense) and automatically connect at the appropriate speed. The ports autoconfigure to operate at either half or full duplex and determine whether to enable or disable flow control. You can also configure Ethernet ports manually. Figure 5-2 shows the faceplate and a block diagram of the card.

Figure 5-2 E100T-G Faceplate and Block Diagram

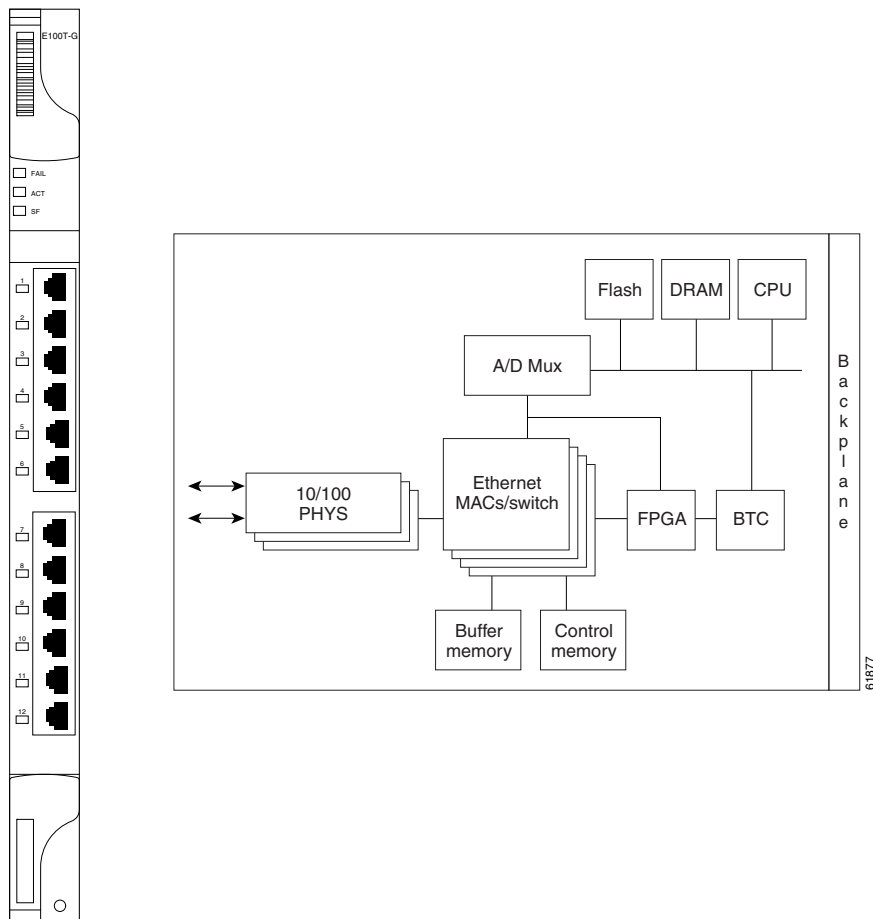

The E100T-G Ethernet card provides high-throughput, low-latency packet switching of Ethernet traffic across a SONET network while providing a greater degree of reliability through SONET self-healing protection services. This Ethernet capability enables network operators to provide multiple 10/100 Mbps access drops for high-capacity customer LAN interconnects, Internet traffic, and cable modem traffic aggregation. It enables the efficient transport and co-existence of traditional TDM traffic with packet-switched data traffic.

Each E100T-G card supports standards-based, wire-speed, Layer 2 Ethernet switching between its Ethernet interfaces. The IEEE 802.1Q tag logically isolates traffic (typically subscribers). IEEE 802.1Q also supports multiple classes of service.

**Note**

When making an STS-12c Ethernet circuit, the E-Series cards must be configured as single-card EtherSwitch.

5.3.1 Slot Compatibility

You can install the E100T-G card in Slots 1 to 6 and 12 to 17. Multiple E-Series Ethernet cards installed in an ONS 15454 can act independently or as a single Ethernet switch. You can create logical SONET ports by provisioning a number of STS channels to the packet switch entity within the ONS 15454. Logical ports can be created with a bandwidth granularity of STS-1. The ONS 15454 supports STS-1, STS-3c, STS-6c, or STS-12c circuit sizes.

5.3.2 E100T-G Card-Level Indicators

The E100T-G card faceplate has two card-level LED indicators, described in [Table 5-5](#).

Table 5-5 E100T-G Card-Level Indicators

Card-Level Indicators	Description
FAIL LED (Red)	The red FAIL LED indicates that the card processor is not ready or that a catastrophic software failure occurred on the E100T-G card. As part of the boot sequence, the FAIL LED is turned on until the software deems the card operational.
ACT LED (Green)	The green ACT LED provides the operational status of the E100T-G. If the ACT LED is green it indicates that the E100T-G card is active and the software is operational.
SF LED	Not used.

5.3.3 E100T-G Port-Level Indicators

The E100T-G card has 12 pairs of LEDs (one pair for each port) to indicate port conditions ([Table 5-6](#)). You can find the status of the E100T-G card port using the LCD screen on the ONS 15454 fan-tray assembly. Use the LCD to view the status of any port or card slot; the screen displays the number and severity of alarms for a given port or slot.

Table 5-6 E100T-G Port-Level Indicators

LED State	Description
Yellow (Active)	Port is active (transmitting or receiving data). By default, indicates the transmitter is active but can be software controlled to indicate link status, duplex status, or receiver active.
Solid Green (Link)	Link is established. By default, indicates the link for this port is up, but can be software controlled to indicate duplex status, operating speed, or collision.

5.3.4 Cross-Connect Compatibility

The E100T-G card is compatible with the XCVT, XC10G and XC-VXC-10G cards.

5.4 E1000-2 Card



Note

For hardware specifications, see the [“A.7.3 E1000-2 Card Specifications”](#) section on page A-46.

The ONS 15454 uses E1000-2 cards for Gigabit Ethernet (1000 Mbps). The E1000-2 card provides two IEEE-compliant, 1000-Mbps ports for high-capacity customer LAN interconnections. Each port supports full-duplex operation.

The E1000-2 card uses GBIC modular receptacles for the optical interfaces. For details, see the [“5.13 Ethernet Card GBICs and SFPs”](#) section on page 5-31.

Figure 5-3 shows the card faceplate and a block diagram of the card.

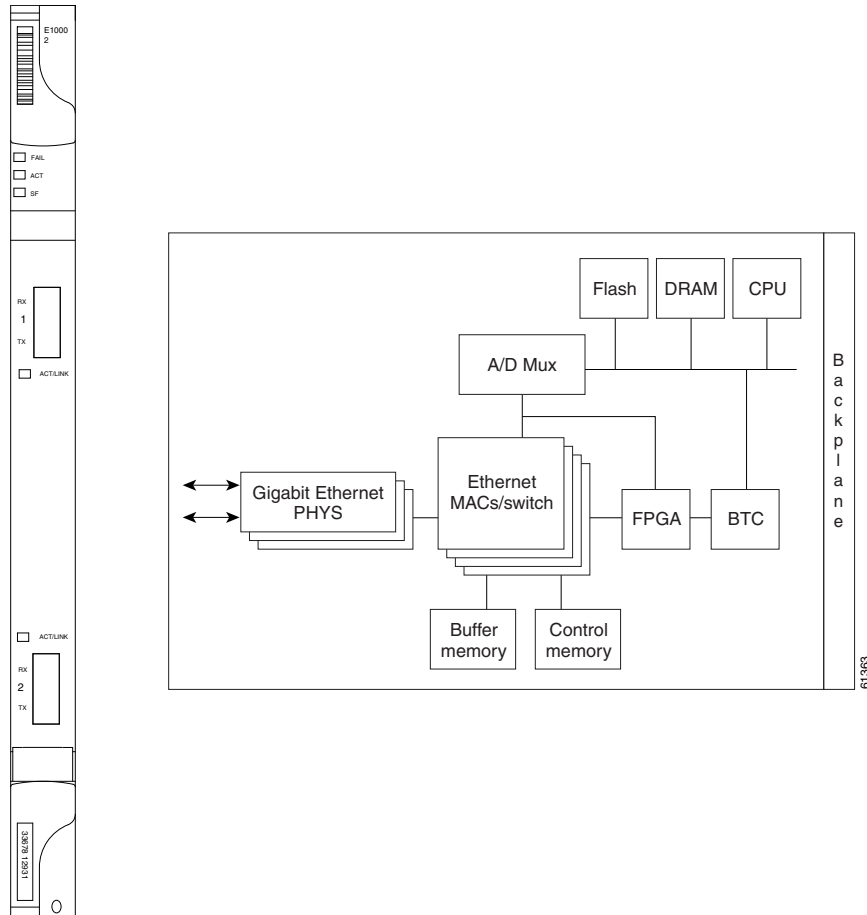
Figure 5-3 E1000-2 Faceplate and Block Diagram

The E1000-2 Gigabit Ethernet card provides high-throughput, low-latency packet switching of Ethernet traffic across a SONET network while providing a greater degree of reliability through SONET self-healing protection services. This enables network operators to provide multiple 1000-Mbps access drops for high-capacity customer LAN interconnects. It enables efficient transport and co-existence of traditional TDM traffic with packet-switched data traffic.

Each E1000-2 card supports standards-based, Layer 2 Ethernet switching between its Ethernet interfaces and SONET interfaces on the ONS 15454. The IEEE 802.1Q VLAN tag logically isolates traffic (typically subscribers).

Multiple E-Series Ethernet cards installed in an ONS 15454 can act together as a single switching entity or as independent single switches supporting a variety of SONET port configurations.

You can create logical SONET ports by provisioning STS channels to the packet switch entity within the ONS 15454. Logical ports can be created with a bandwidth granularity of STS-1. The ONS 15454 supports STS-1, STS-3c, STS-6c, or STS-12c circuit sizes.

**Note**

When making an STS-12c circuit, the E-Series cards must be configured as single-card EtherSwitch.

5.4.1 Slot Compatibility

You can install the E1000-2 card in Slots 1 to 6 and 12 to 17. The E1000-2 is compatible with the XCVT card but not the XC10G or and XC-VXC-10G cards. The E1000-2-G is compatible with the XC10G and XC-VXC-10G.

5.4.2 E1000-2 Card-Level Indicators

The E1000-2 card faceplate has two card-level LED indicators, described in [Table 5-7](#).

Table 5-7 E1000-2 Card-Level Indicators

Card-Level Indicators	Description
FAIL LED (Red)	The red FAIL LED indicates that the card processor is not ready or that a catastrophic software failure occurred on the E1000-2 card. As part of the boot sequence, the FAIL LED is turned on until the software deems the card operational.
ACT LED (Green)	The green ACT LED provides the operational status of the E1000-2. When the ACT LED is green it indicates that the E1000-2 card is active and the software is operational.
SF LED	Not used.

5.4.3 E1000-2 Port-Level Indicators

The E1000-2 card has one bicolor LED per port ([Table 5-8](#)). When the LED is solid green, it indicates that carrier is detected, meaning an active network cable is installed. When the LED is off, it indicates that an active network cable is not plugged into the port, or the card is carrying unidirectional traffic. When the LED flashes amber, it does so at a rate proportional to the level of traffic being received and transmitted over the port.

Table 5-8 E1000-2 Port-Level Indicators

LED State	Description
Amber	The port is active (transmitting and receiving data).
Solid green	The link is established.
Off	The connection is inactive, or traffic is unidirectional.

5.4.4 Cross-Connect Compatibility

The E1000-2 is compatible with XCVT cards. The XC10G and XC-VXC-10G cards require the E1000-2-G card.

5.5 E1000-2-G Card

**Note**

For hardware specifications, see the [“A.7.4 E1000-2-G Card Specifications”](#) section on page A-46.

The ONS 15454 uses E1000-2-G cards for Gigabit Ethernet (1000 Mbps). The E1000-2-G card provides two IEEE-compliant, 1000-Mbps ports for high-capacity customer LAN interconnections. Each port supports full-duplex operation.

The E1000-2-G card uses GBIC modular receptacles for the optical interfaces. For details, see the [“5.13 Ethernet Card GBICs and SFPs”](#) section on page 5-31.

[Figure 5-4](#) shows the card faceplate and a block diagram of the card.

Figure 5-4 E1000-2-G Faceplate and Block Diagram

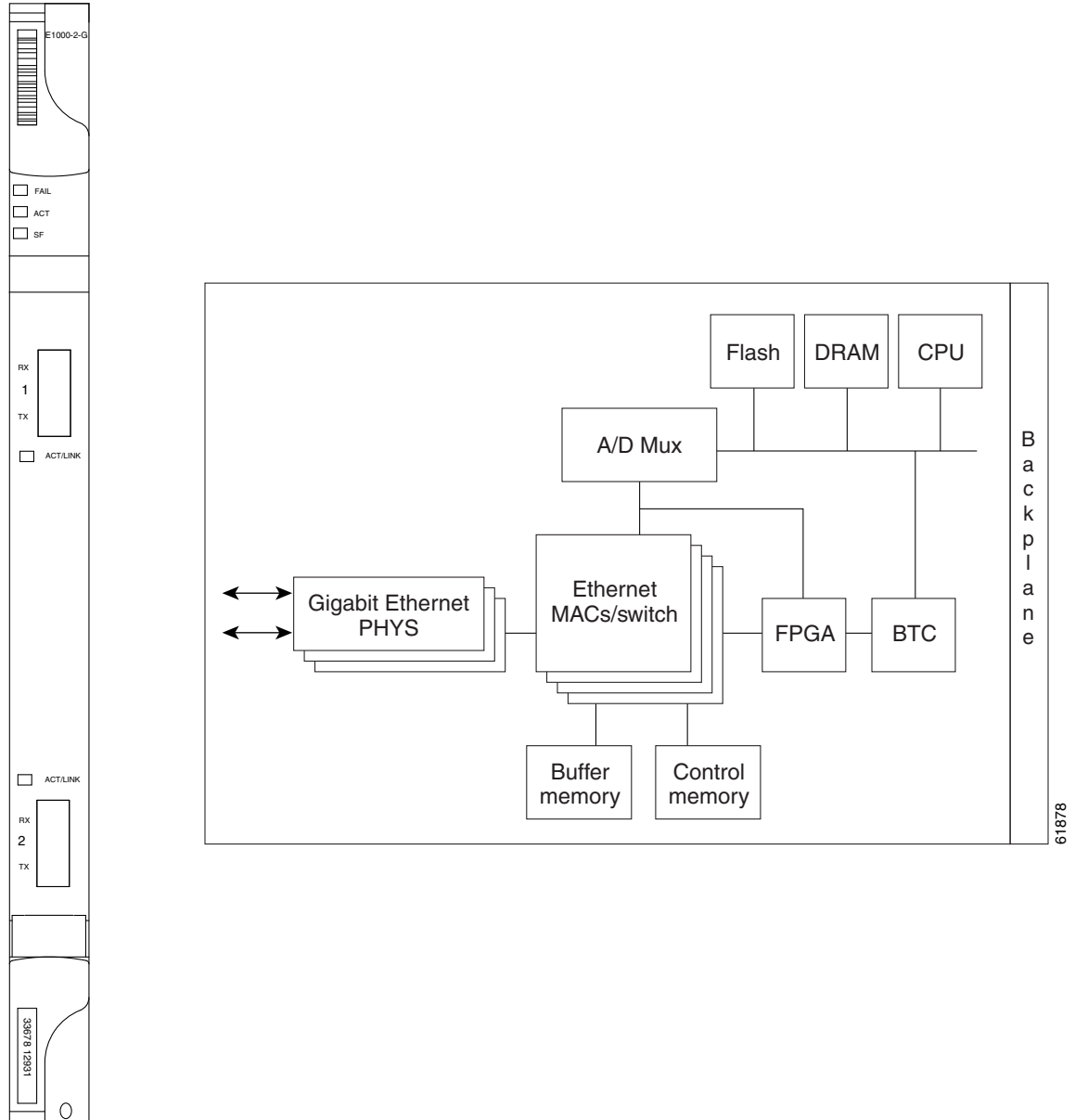

The E1000-2-G Gigabit Ethernet card provides high-throughput, low-latency packet switching of Ethernet traffic across a SONET network while providing a greater degree of reliability through SONET self-healing protection services. This enables network operators to provide multiple 1000-Mbps access drops for high-capacity customer LAN interconnects. It enables efficient transport and co-existence of traditional TDM traffic with packet-switched data traffic.

Each E1000-2-G card supports standards-based, Layer 2 Ethernet switching between its Ethernet interfaces and SONET interfaces on the ONS 15454. The IEEE 802.1Q VLAN tag logically isolates traffic (typically subscribers).

Multiple E-Series Ethernet cards installed in an ONS 15454 can act together as a single switching entity or as independent single switches supporting a variety of SONET port configurations.

You can create logical SONET ports by provisioning STS channels to the packet switch entity within the ONS 15454. Logical ports can be created with a bandwidth granularity of STS-1. The ONS 15454 supports STS-1, STS-3c, STS-6c, or STS-12c circuit sizes.

**Note**

When making an STS-12c Ethernet circuit, the E-Series cards must be configured as a single-card EtherSwitch.

5.5.1 E1000-2-G Card-Level Indicators

The E1000-2-G card faceplate has two card-level LED indicators, described in [Table 5-9](#).

Table 5-9 E1000-2-G Card-Level Indicators

Card-Level Indicators	Description
FAIL LED (Red)	The red FAIL LED indicates that the card processor is not ready or that a catastrophic software failure occurred on the E1000-2-G card. As part of the boot sequence, the FAIL LED is turned on until the software deems the card operational.
ACT LED (Green)	The green ACT LED provides the operational status of the E1000-2-G. If the ACT LED is green it indicates that the E1000-2-G card is active and the software is operational.
SF LED	The SF LED is not used in the current release.

5.5.2 E1000-2-G Port-Level Indicators

The E1000-2-G card has one bicolor LED per port ([Table 5-10](#)). When the green LINK LED is on, carrier is detected, meaning an active network cable is installed. When the green LINK LED is off, an active network cable is not plugged into the port, or the card is carrying unidirectional traffic. The amber port ACT LED flashes at a rate proportional to the level of traffic being received and transmitted over the port.

Table 5-10 E1000-2-G Port-Level Indicators

LED State	Description
Amber	The port is active (transmitting and receiving data).
Solid green	The link is established.
Off	The connection is inactive, or traffic is unidirectional.

5.5.3 Cross-Connect Compatibility

The E1000-2-G is compatible with the XCVT, XC10G, and XC-VXC-10G cards. You can install the card in Slots 1 to 6 and 12 to 17.

5.6 G1000-4 Card

The G1000-4 card requires the XC10G card. The ONS 15454 uses G1000-4 cards for Gigabit Ethernet (1000 Mbps). The G1000-4 card provides four ports of IEEE-compliant, 1000-Mbps interfaces. Each port supports full-duplex operation for a maximum bandwidth of OC-48 on each card.

The G1000-4 card uses GBIC modular receptacles for the optical interfaces. For details, see the “5.13 Ethernet Card GBICs and SFPs” section on page 5-31.



Note

Any new features that are available as part of this software release are not enabled for this card.

Figure 5-5 shows the card faceplate and the block diagram of the card.

Figure 5-5 G1000-4 Faceplate and Block Diagram

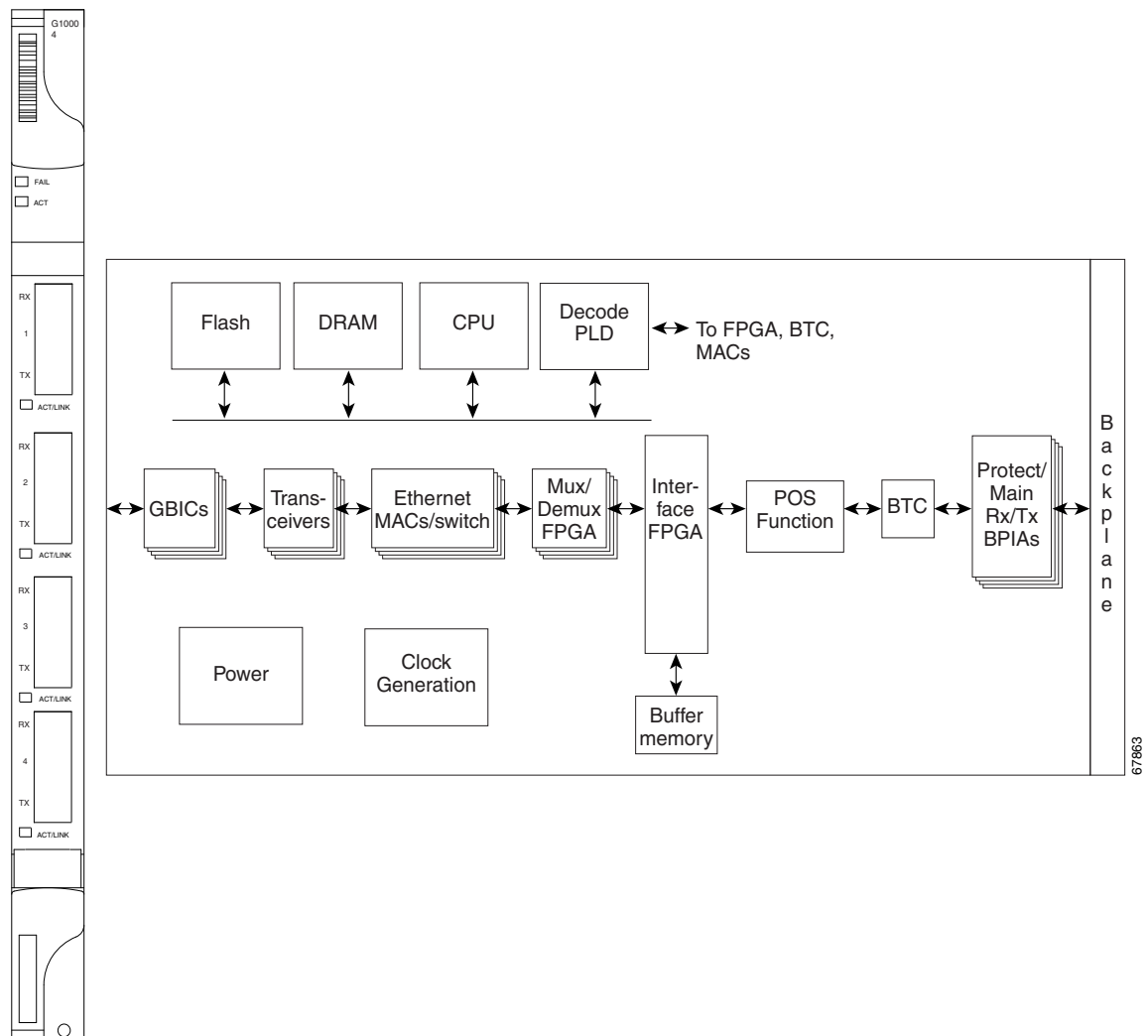

The G1000-4 Gigabit Ethernet card provides high-throughput, low latency transport of Ethernet encapsulated traffic (IP and other Layer 2 or Layer 3 protocols) across a SONET network. Carrier-class Ethernet transport is achieved by hitless (< 50 ms) performance in the event of any failures or protection

switches (such as 1+1 automatic protection switching [APS], path protection, or bidirectional line switch ring [BLSR]). Full provisioning support is possible through Cisco Transport Controller (CTC), Transaction Language One (TL1), or Cisco Transport Manager (CTM).

The circuit sizes supported are STS-1, STS-3c, STS-6c, STS-9c, STS-12c, STS-24c, and STS-48c.

5.6.1 STS-24c Restriction

Due to hardware constraints, the card imposes an additional restriction on the combinations of circuits that can be dropped onto a G-Series card. These restrictions are transparently enforced by the ONS 15454, and you do not need to keep track of restricted circuit combinations.

When a single STS-24c terminates on a card, the remaining circuits on that card can be another single STS-24c or any combination of circuits of STS-12c size or less that add up to no more than 12 STSs (that is a total of 36 STSs on the card).

If STS-24c circuits are not being dropped on the card, the full 48 STSs bandwidth can be used with no restrictions (for example, using either a single STS-48c or 4 STS-12c circuits).



Note

The STS-24c restriction only applies when a single STS-24c circuit is dropped; therefore, you can easily minimize the impact of this restriction. Group the STS-24c circuits together on a card separate from circuits of other sizes. The grouped circuits can be dropped on other G-Series cards on the ONS 15454.

5.6.2 G1000-4 Card-Level Indicators

The G1000-4 card faceplate has two card-level LED indicators, described in [Table 5-11](#).

Table 5-11 G1000-4 Card-Level Indicators

Card-Level LEDs	Description
FAIL LED (red)	The red FAIL LED indicates that the card's processor is not ready or that a catastrophic software failure occurred on the G1000-4 card. As part of the boot sequence, the FAIL LED is turned on, and it turns off if the software is deemed operational. The red FAIL LED blinks when the card is loading software.
ACT LED (green)	A green ACT LED provides the operational status of the G1000-4. If the ACT LED is green, it indicates that the G1000-4 card is active and the software is operational.

5.6.3 G1000-4 Port-Level Indicators

The G1000-4 card has one bicolor LED per port. [Table 5-12](#) describes the status that each color represents.

Table 5-12 G1000-4 Port-Level Indicators

Port-Level LED Status	Description
Off	No link exists to the Ethernet port.
Steady amber	A link exists to the Ethernet port, but traffic flow is inhibited. For example, an unconfigured circuit, an error on line, or a nonenabled port might inhibit traffic flow.
Solid green	A link exists to the Ethernet port, but no traffic is carried on the port.
Flashing green	A link exists to the Ethernet port, and traffic is carried on the port. The LED flash rate reflects the traffic rate for the port.

5.6.4 Slot Compatibility

The G1000-4 card requires Cisco ONS 15454 Release 3.2 or later system software and the XC10G cross-connect card. You can install the card in Slots 1 to 6 and 12 to 17, for a total shelf capacity of 48 Gigabit Ethernet ports. The practical G1000-4 port per shelf limit is 40, because at least two slots are typically filled by OC-N trunk cards such as the OC-192.

5.7 G1K-4 Card



Note

For hardware specifications, see the [“A.7.7 G1K-4 Card Specifications”](#) section on page A-47.

The G1K-4 card is the functional equivalent of the earlier G1000-4 card and provides four ports of IEEE-compliant, 1000-Mbps interfaces. Each interface supports full-duplex operation for a maximum bandwidth of 1 Gbps or 2 Gbps bidirectional per port, and 2.5 Gbps or 5 Gbps bidirectional per card. Each port autonegotiates for full duplex and IEEE 802.3x flow control. The G1K-4 card uses GBIC modular receptacles for the optical interfaces. For details, see the [“5.13 Ethernet Card GBICs and SFPs”](#) section on page 5-31.

Figure 5-6 shows the card faceplate and the block diagram of the card.

Figure 5-6 G1K-4 Faceplate and Block Diagram

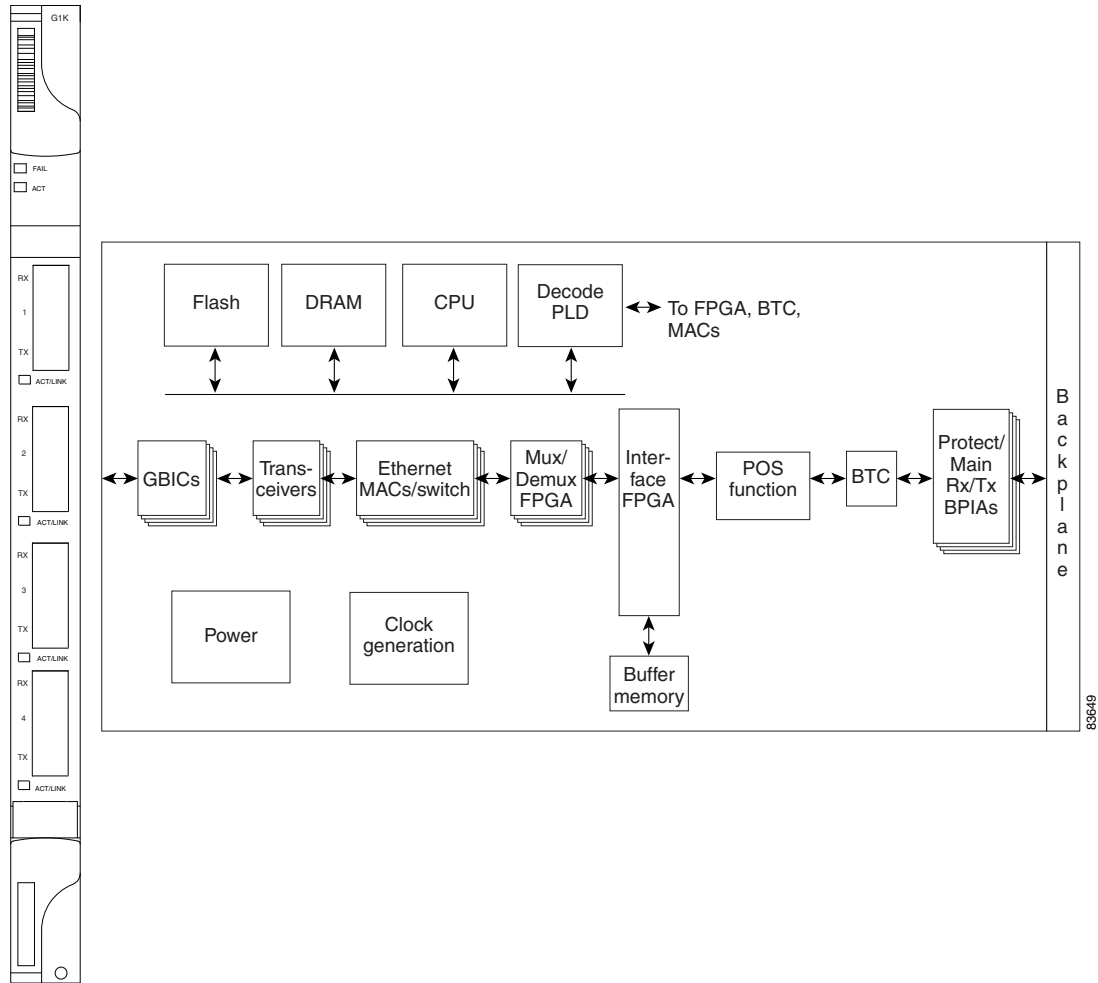

The G1K-4 Gigabit Ethernet card provides high-throughput, low-latency transport of Ethernet encapsulated traffic (IP and other Layer 2 or Layer 3 protocols) across a SONET network while providing a greater degree of reliability through SONET self-healing protection services. Carrier-class Ethernet transport is achieved by hitless (< 50 ms) performance in the event of any failures or protection switches (such as 1+1 APS, path protection, BLSR, or optical equipment protection) and by full provisioning and manageability, as in SONET service. Full provisioning support is possible through CTC or CTM. Each G1K-4 card performs independently of the other cards in the same shelf.

5.7.1 STS-24c Restriction

Due to hardware constraints, the card imposes an additional restriction on the combinations of circuits that can be dropped onto a G-Series card. These restrictions are transparently enforced by the ONS 15454, and you do not need to keep track of restricted circuit combinations.

When a single STS-24c terminates on a card, the remaining circuits on that card can be another single STS-24c or any combination of circuits of STS-12c size or less that add up to no more than 12 STSs (that is a total of 36 STSs on the card).

If STS-24c circuits are not being dropped on the card, the full 48 STSs bandwidth can be used with no restrictions (for example, using either a single STS-48c or 4 STS-12c circuits).

**Note**

The STS-24c restriction only applies when a single STS-24c circuit is dropped; therefore, you can easily minimize the impact of this restriction. Group the STS-24c circuits together on a card separate from circuits of other sizes. The grouped circuits can be dropped on other G-Series cards on the ONS 15454.

5.7.2 G1K-4 Compatibility

The G1K-4 card operates with the XCVT, XC10G or XC-VXC-10G cards. With the XC10G or XC-VXC-10G cards, you can install the G1K-4 card in Slots 1 to 6 and 12 to 17, for a total shelf capacity of 48 Gigabit Ethernet ports. (The practical limit is 40 ports because at least two slots are typically populated by optical cards such as OC-192). When used with the XCVT cards, the G1K-4 is limited to Slots 5, 6, 12, and 13.

5.7.3 G1K-4 Card-Level Indicators

The G1K-4 card faceplate has two card-level LED indicators, described in [Table 5-13](#).

Table 5-13 G1K-4 Card-Level Indicators

Card-Level LEDs	Description
FAIL LED (Red)	The red FAIL LED indicates that the card processor is not ready or that a catastrophic software failure occurred on the G1K-4 card. As part of the boot sequence, the FAIL LED is turned on, and it goes off when the software is deemed operational. The red FAIL LED blinks when the card is loading software.
ACT LED (Green)	The green ACT LED provides the operational status of the G1K-4. If the ACT LED is green, it indicates that the G1K-4 card is active and the software is operational.

5.7.4 G1K-4 Port-Level Indicators

The G1K-4 card has four bicolor LEDs (one LED per port). [Table 5-14](#) describes the status that each color represents.

Table 5-14 G1K-4 Port-Level Indicators

Port-Level LED Status	Description
Off	No link exists to the Ethernet port.
Steady amber	A link exists to the Ethernet port, but traffic flow is inhibited. For example, a lack of circuit setup, an error on the line, or a nonenabled port might inhibit traffic flow.

Table 5-14 G1K-4 Port-Level Indicators (continued)

Port-Level LED Status	Description
Solid green	A link exists to the Ethernet port, but no traffic is carried on the port.
Flashing green	A link exists to the Ethernet port, and traffic is carried on the port. The LED flash rate reflects the traffic rate for the port.

5.8 ML100T-12 Card

**Note**

For hardware specifications, see the [“A.7.8 ML100T-12 Card Specifications”](#) section on page A-47.

The ML100T-12 card provides 12 ports of IEEE 802.3-compliant, 10/100 interfaces. Each interface supports full-duplex operation for a maximum bandwidth of 200 Mbps per port and 2.488 Gbps per card. Each port independently detects the speed of an attached device (autosenses) and automatically connects at the appropriate speed. The ports autoconfigure to operate at either half or full duplex and can determine whether to enable or disable flow control. For ML-Series configuration information, see the *Ethernet Card Software Feature and Configuration Guide for the Cisco ONS 15454, Cisco ONS 15454 SDH, and Cisco ONS 15327*.

[Figure 5-7](#) shows the card faceplate and block diagram.

**Caution**

Shielded twisted-pair cabling should be used for inter-building applications.

Figure 5-7 ML100T-12 Faceplate and Block Diagram

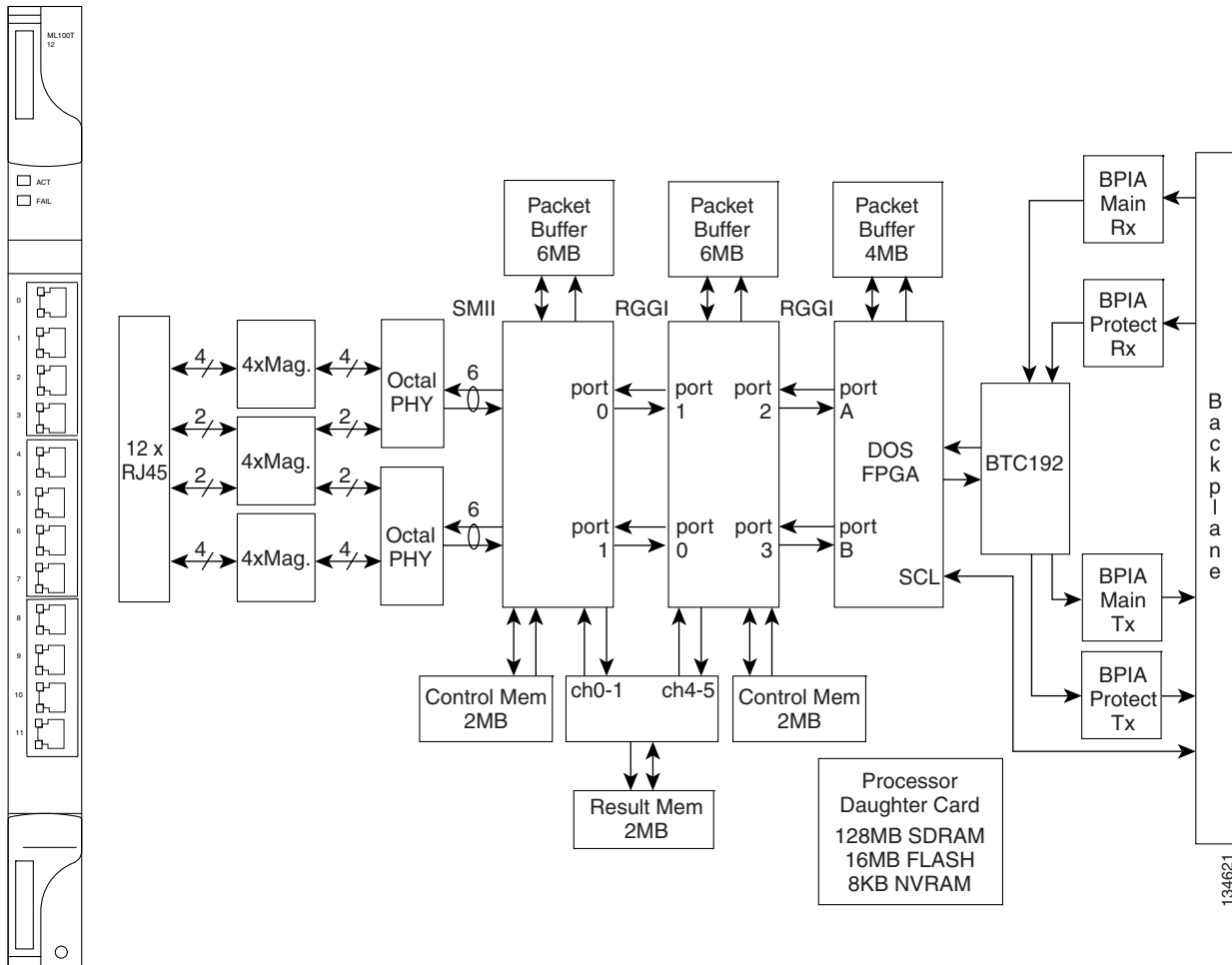

The card features two virtual packet over SONET (POS) ports with a maximum combined bandwidth of STS-48. The ports function in a manner similar to OC-N card ports, and each port carries an STS circuit with a size of STS-1, STS-3c, STS-6c, STS-9c, STS-12c, or STS-24c. To configure an ML-Series card SONET STS circuit, refer to the “Create Circuits and VT Tunnels” chapter of the *Cisco ONS 15454 Procedure Guide*.

The ML-Series POS ports supports virtual concatenation (VCAT) of SONET circuits and a software link capacity adjustment scheme (SW-LCAS). The ML-Series card supports a maximum of two VCAT groups with each group corresponding to one of the POS ports. Each VCAT group must be provisioned with two circuit members. An ML-Series card supports STS-1c-2v, STS-3c-2v and STS-12c-2v. To configure an ML-Series card SONET VCAT circuit, refer to the “Create Circuits and VT Tunnels” chapter of the *Cisco ONS 15454 Procedure Guide*.

5.8.1 ML100T-12 Card-Level Indicators

The ML00T-12 card supports two card-level LED indicators. The card-level indicators are described in [Table 5-15](#).

Table 5-15 ML100T-12 Card-Level Indicators

Card-Level LEDs	Description
FAIL LED (Red)	The red FAIL LED indicates that the card processor is not ready or that a catastrophic software failure occurred on the ML100T-12 card. As part of the boot sequence, the FAIL LED is turned on until the software deems the card operational.
ACT LED (Green)	The green ACT LED provides the operational status of the ML100T-12. If the ACT LED is green, it indicates that the ML100T-12 card is active and the software is operational.

5.8.2 ML100T-12 Port-Level Indicators

The ML100T-12 card provides a pair of LEDs for each Fast Ethernet port: an amber LED for activity (ACT) and a green LED for LINK. The port-level indicators are described in [Table 5-16](#).

Table 5-16 ML100T-12 Port-Level Indicators

Port-Level Indicators	Description
ACT LED (Amber)	A steady amber LED indicates a link is detected, but there is an issue inhibiting traffic. A blinking amber LED means traffic is flowing.
LINK LED (Green)	A steady green LED indicates that a link is detected, but there is no traffic. A blinking green LED flashes at a rate proportional to the level of traffic being received and transmitted over the port.
Both ACT and LINK LED	Unlit green and amber LEDs indicate no traffic.

5.8.3 Cross-Connect and Slot Compatibility

The ML100T-12 card works in Slots 1 to 6 or 12 to 17 with the XC10G or XC-VXC-10G card. It works only in Slots 5, 6, 12, or 13 with the XCVT card.

5.9 ML100X-8 Card



Note

For hardware specifications, see the [“A.7.10 ML100X-8 Card Specifications”](#) section on page A-48.

The ML100X-8 card provides eight ports with 100 base FX interfaces. The FX interfaces support one of two connectors, an LX SFP or an FX SFP. The LX SFP is a 100 Mbps 802.3-compliant SFP that operates over a pair of single-mode optical fibers and includes LC connectors. The FX SFP is a 100 Mbps 802.3-compliant SFP that operates over a pair of multimode optical fibers and includes LC connectors. For more information on SFPs, see the [“5.13 Ethernet Card GBICs and SFPs”](#) section on page 5-31.

Each interface supports full-duplex operation for autonegotiation and a maximum bandwidth of 200 Mbps per port and 2.488 Gbps per card. For ML-Series configuration information, see the *Ethernet Card Software Feature and Configuration Guide for the Cisco ONS 15454, Cisco ONS 15454 SDH, and Cisco ONS 15327*.

Figure 5-8 shows the card faceplate and block diagram.

Figure 5-8 ML100X-8 Faceplate and Block Diagram

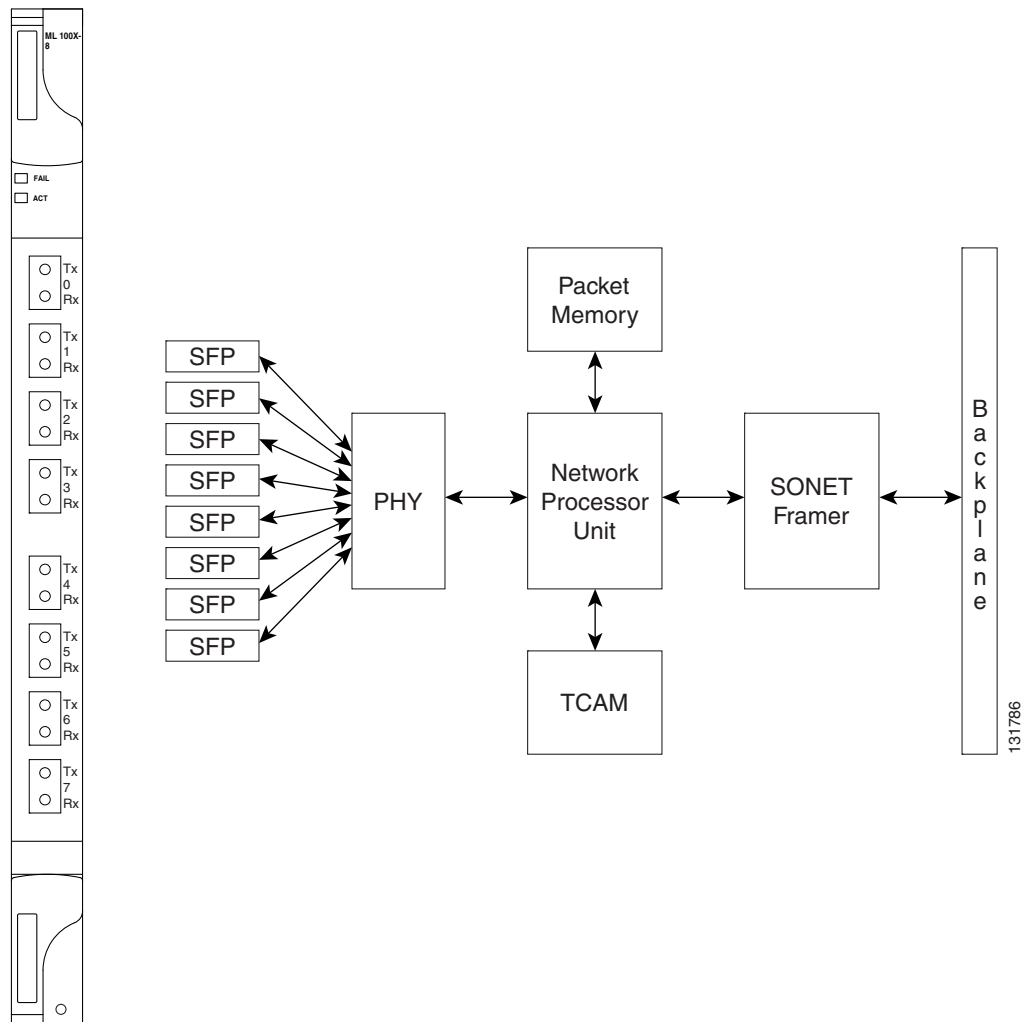

The card features two virtual packet over SONET (POS) ports with a maximum combined bandwidth of STS-48. The ports function in a manner similar to OC-N card ports, and each port carries an STS circuit with a size of STS-1, STS-3c, STS-6c, STS-9c, STS-12c, or STS-24c. To configure an ML-Series card SONET STS circuit, refer to the “Create Circuits and VT Tunnels” chapter of the *Cisco ONS 15454 Procedure Guide*.

The ML-Series POS ports supports virtual concatenation (VCAT) of SONET circuits and a software link capacity adjustment scheme (SW-LCAS). The ML-Series cards support a maximum of two VCAT groups with each group corresponding to one of the POS ports. Each VCAT group must be provisioned with two circuit members. An ML-Series card supports STS-1c-2v, STS-3c-2v and STS-12c-2v. To configure an ML-Series-card SONET VCAT circuit, refer to the “Create Circuits and VT Tunnels” chapter of the *Cisco ONS 15454 Procedure Guide*.

5.9.1 ML100X-8 Card-Level Indicators

The ML100X-8 card supports two card-level LED indicators. [Table 5-17](#) describes the card-level indicators.

Table 5-17 ML100X-8 Card-Level Indicators

Card-Level LEDs	Description
FAIL LED (Red)	The red FAIL LED indicates that the card processor is not ready or that a catastrophic software failure occurred on the ML100-FX card. As part of the boot sequence, the FAIL LED is turned on until the software deems the card operational.
ACT LED (Green)	The green ACT LED provides the operational status of the ML100-FX. If the ACT LED is green, it indicates that the ML100-FX card is active and the software is operational.

5.9.2 ML100X-8 Port-Level Indicators

The ML100X-8 card provides a pair of LEDs for each Fast Ethernet port: an amber LED for activity (ACT) and a green LED for LINK. [Table 5-18](#) describes the port-level indicators.

Table 5-18 ML100X-8 Port-Level Indicators

Port-Level Indicators	Description
ACT LED (Amber)	A steady amber LED indicates a link is detected, but there is an issue inhibiting traffic. A blinking amber LED means traffic is flowing.
LINK LED (Green)	A steady green LED indicates that a link is detected, but there is no traffic. A blinking green LED flashes at a rate proportional to the level of traffic being received and transmitted over the port.
Both ACT and LINK LED	Unlit green and amber LEDs indicate no traffic.

5.9.3 Cross-Connect and Slot Compatibility

The ML100X-8 card operates in Slots 1 to 6 or 12 to 17 with the XC10G or XC-VXC-10G cards. It operates only in Slots 5, 6, 12, or 13 with the XCVT card.

5.10 ML1000-2 Card



Note

For hardware specifications, see the [“A.7.9 ML1000-2 Card Specifications”](#) section on page A-48.

The ML1000-2 card provides two ports of IEEE-compliant, 1000-Mbps interfaces. Each interface supports full-duplex operation for a maximum bandwidth of 2 Gbps per port and 4 Gbps per card. Each port autoconfigures for full duplex and IEEE 802.3x flow control.

SFP modules are offered as separate orderable products for maximum customer flexibility. For details, see the “5.13 Ethernet Card GBICs and SFPs” section on page 5-31.

Figure 5-9 shows the ML1000-2 card faceplate.

Figure 5-9 ML1000-2 Faceplate

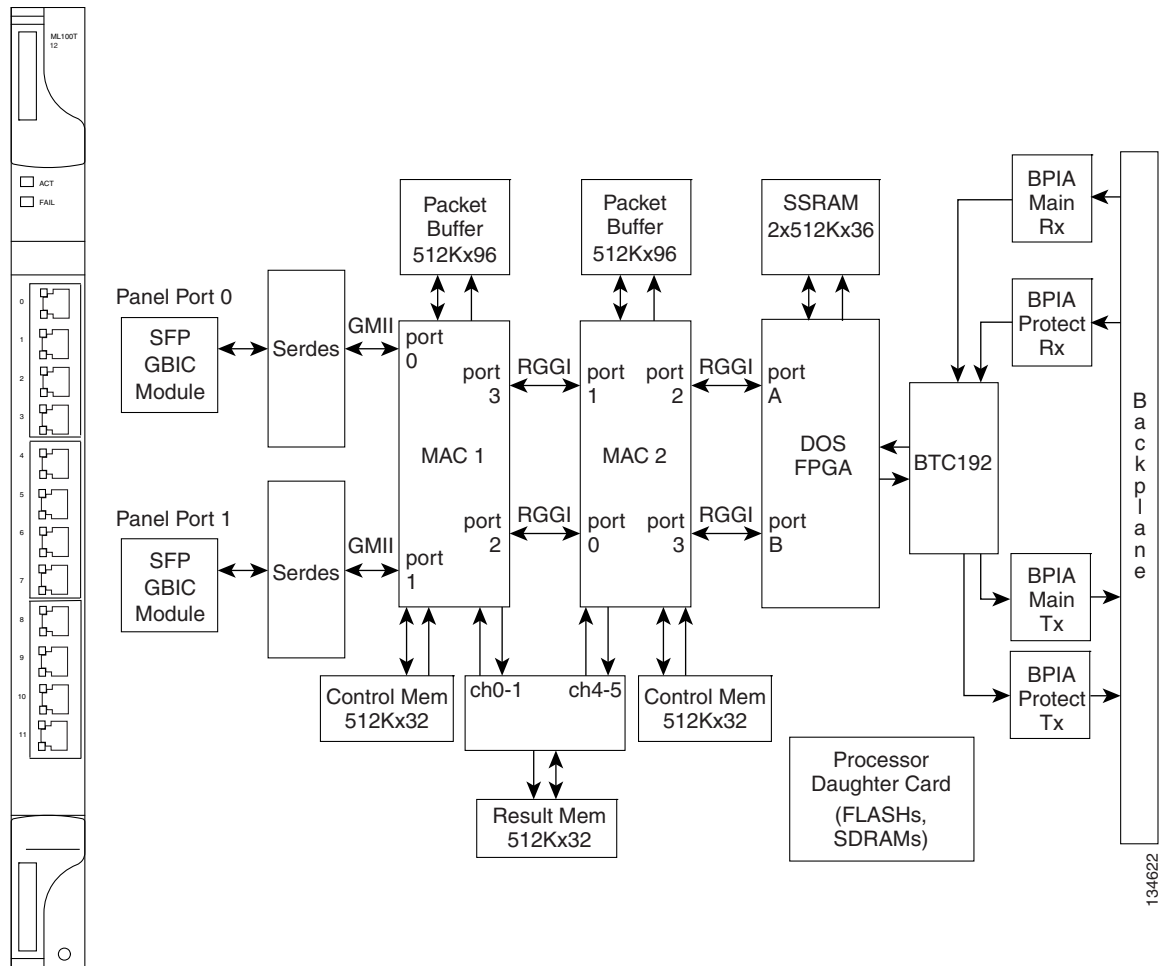

The card features two virtual packet over SONET (POS) ports with a maximum combined bandwidth of STS-48. The ports function in a manner similar to OC-N card ports, and each port carries an STS circuit with a size of STS-1, STS-3c, STS-6c, STS-9c, STS-12c, or STS-24c. To configure an ML-Series card SONET STS circuit, refer to the “Create Circuits and VT Tunnels” chapter of the *Cisco ONS 15454 Procedure Guide*.

The ML-Series POS ports supports VCAT of SONET circuits and a software link capacity adjustment scheme (SW-LCAS). The ML-Series card supports a maximum of two VCAT groups with each group corresponding to one of the POS ports. Each VCAT group must be provisioned with two circuit members. An ML-Series card supports STS-1c-2v, STS-3c-2v and STS-12c-2v. To configure an ML-Series card SONET VCAT circuit, refer to the “Create Circuits and VT Tunnels” chapter of the *Cisco ONS 15454 Procedure Guide*.

5.10.1 ML1000-2 Card-Level Indicators

The ML1000-2 card faceplate has two card-level LED indicators, described in [Table 5-19](#).

Table 5-19 ML1000-2 Card-Level Indicators

Card-Level LEDs	Description
SF LED (Red)	The red FAIL LED indicates that the card processor is not ready or that a catastrophic software failure occurred on the ML1000-2 card. As part of the boot sequence, the FAIL LED is turned on until the software deems the card operational.
ACT LED (Green)	The green ACT LED provides the operational status of the ML1000-2. When the ACT LED is green, it indicates that the ML1000-2 card is active and the software is operational.

5.10.2 ML1000-2 Port-Level Indicators

The ML1000-2 card has three LEDs for each of the two Gigabit Ethernet ports, described in [Table 5-20](#).

Table 5-20 ML1000-2 Port-Level Indicators

Port-Level Indicators	Description
ACT LED (Amber)	A steady amber LED indicates a link is detected, but there is an issue inhibiting traffic. A blinking amber LED means traffic flowing.
LINK LED (Green)	A steady green LED indicates that a link is detected, but there is no traffic. A blinking green LED flashes at a rate proportional to the level of traffic being received and transmitted over the port.
Both ACT and LINK LED	Unlit green and amber LEDs indicate no traffic.

5.10.3 Cross-Connect and Slot Compatibility

The ML1000-2 card is compatible in Slots 1 to 6 or 12 to 17 with the XC10G or XC-VXC-10G card. It is only compatible in Slots 5, 6, 12, or 13 with the XCVT card.

5.11 CE-100T-8 Card



Note

For hardware specifications, see the [“A.7.6 CE-100T-8 Card Specifications”](#) section on page A-47.

The CE-100T-8 card provides eight RJ-45 10/100 Mbps Ethernet ports and an RJ-45 console port on the card faceplate. The CE-100T-8 card provides mapping of 10/100 Mbps Ethernet traffic into SONET STS-12 payloads, making use of low-order (VT1.5) virtual concatenation, high-order (STS-1) virtual concatenation, generic framing procedure (GFP), and point-to-point protocol/high-level data link control (PPP/HDLC) framing protocols.

The CE-100T8 card also supports the link capacity adjustment scheme (LCAS), which allows hitless dynamic adjustment of SONET link bandwidth. The CE-100T-8 card's LCAS is hardware-based, but the CE-100T-8 also supports SW-LCAS. This makes it compatible with the ONS 15454 SDH ML-Series card, which supports only SW-LCAS and does not support the standard hardware-based LCAS. SW-LCAS is supported when a circuit from the CE-100T-8 terminates on the ONS 15454 SDH ML-Series card.

The circuit types supported are:

- HO-CCAT
- LO-VCAT with no HW-LCAS
- LO-VCAT with HW-LCAS
- STS-1-2v SW-LCAS with ML only.

Each 10/100 Ethernet port can be mapped to a SONET channel in increments of VT1.5 or STS-1 granularity, allowing efficient transport of Ethernet and IP over the SONET infrastructure.

Figure 5-10 shows the CE-100T-8 card faceplate and block diagram.

Figure 5-10 CE-100T-8 Faceplate and Block Diagram

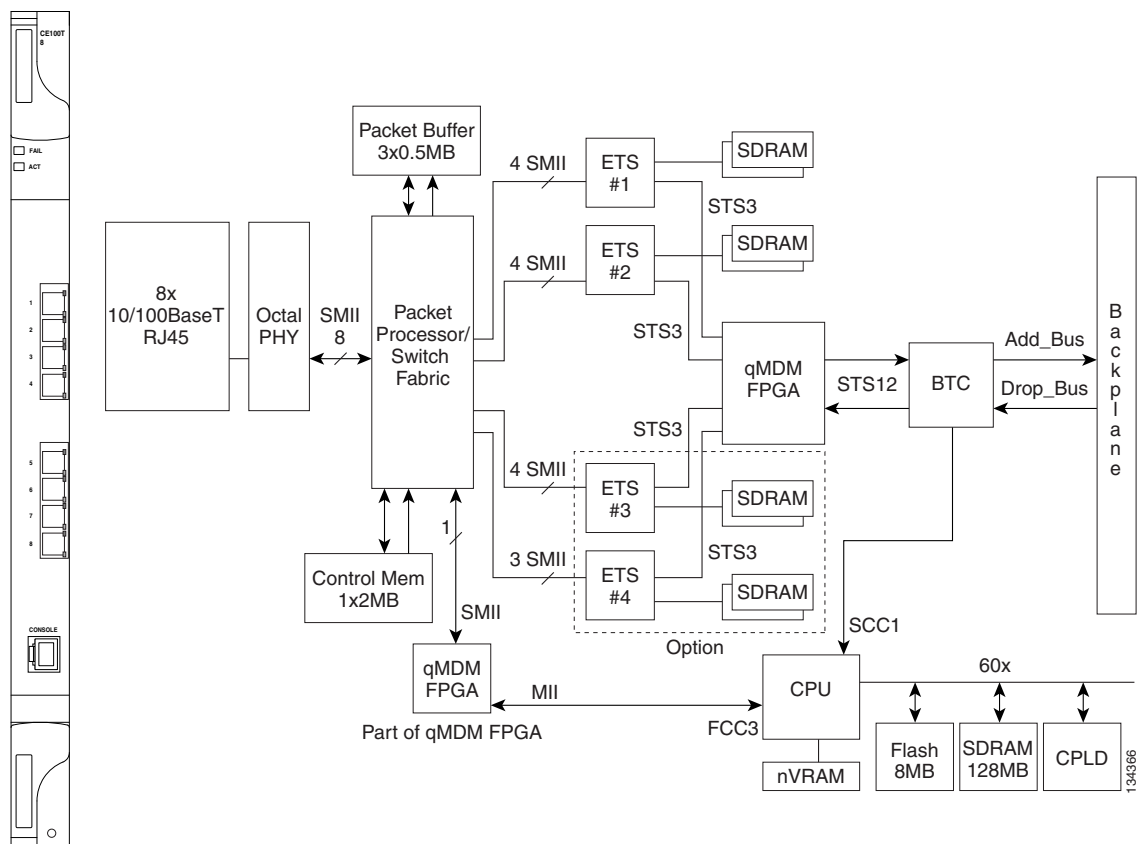

The following paragraphs describe the general functions of the CE-100T-8 card and relate to the block diagram.

In the ingress direction, (Ethernet-to-SONET), the PHY, which performs all of the physical layer interface functions for 10/100 Mbps Ethernet, sends the frame to the network processor for queuing in the respective packet buffer memory. The network processor performs packet processing, packet

switching, and classification. The Ethernet frames are then passed to the Ethermap where Ethernet traffic is terminated and is encapsulated using HDLC or GFP framing on a per port basis. The encapsulated Ethernet frames are then mapped into a configurable number of virtual concatenated low and high order payloads, such as VT1.5 synchronous payload envelope (SPE), STS-1 SPE, or a contiguous concatenated payload such as STS-3c SPE. Up to 64 VT1.5 SPEs or 3 STS-1 SPEs can be virtually concatenated. The SONET SPE carrying encapsulated Ethernet frames are passed onto the qMDM FPGA, where four STS-3 frames are multiplexed to form a STS-12 frame for transport over the SONET network by means of the Bridging Convergence Transmission (BTC) ASIC.

In the Egress direction (SONET-to-Ethernet), the FPGA extracts four STS-3 SPEs from the STS-12 frame it receives from the BTC and sends each of the STS-3s to the ET3 mappers. The STS-3 SONET SPE carrying GFP or PPP/HDLC encapsulated Ethernet frames is then extracted and buffered in Ethermap's external memory. This memory is used for providing alignment and differential delay compensation for the received low-order and high-order virtual concatenated payloads. After alignment and delay compensation have been done, the Ethernet frames are decapsulated with one of the framing protocols (GFP or HDLC). Decapsulated Ethernet frames are then passed onto the network processor for QoS queuing and traffic scheduling. The network processor switches the frame to one of the corresponding PHY channels and then to the Ethernet port for transmission to the external client(s).

For information on the CE-100T-8 QoS features, refer to the "CE-100T-8 Operations" chapter of the *Ethernet Card Software Feature and Configuration Guide for the Cisco ONS 15454, Cisco ONS 15454, and Cisco ONS 15327*.

5.11.1 CE-100T-8 Card-Level Indicators

The CE-100T-8 card faceplate has two card-level LED indicators, described in [Table 5-21](#).

Table 5-21 CE-100T-8 Card-Level Indicators

Card-Level LEDs	Description
SF LED (Red)	The red FAIL LED indicates that the card processor is not ready or that a catastrophic software failure occurred on the CE-100T-8 card. As part of the boot sequence, the FAIL LED is turned on until the software deems the card operational.
ACT LED (Green)	The green ACT LED provides the operational status of the CE-100T-8. When the ACT LED is green, it indicates that the CE-100T-8 card is active and the software is operational.

5.11.2 CE-100T-8 Port-Level Indicators

The CE-100T-8 card has two LEDs embedded into each of the eight Ethernet port RJ-45 connectors. The LEDs are described in [Table 5-22](#).

Table 5-22 CE-100T-8 Port-Level Indicators

Port-Level Indicators	Description
ACT LED (Amber)	A steady amber LED indicates a link is detected, but there is an issue inhibiting traffic. A blinking amber LED means traffic flowing.
LINK LED (Green)	A steady green LED indicates that a link is detected, but there is no traffic. A blinking green LED flashes at a rate proportional to the level of traffic being received and transmitted over the port.
Both ACT and LINK LED OFF	Unlit green and amber LEDs indicate no traffic.

5.11.3 Cross-Connect and Slot Compatibility

The CE-100T-8 card is compatible in Slots 1 to 6 or 12 to 17 with the XC10G, XC-VXC-10G, or XCVT cards.

5.12 CE-1000-4 Card



Note

For hardware specifications, see the [“A.7.5 CE-1000-4 Card Specifications”](#) section on page A-46.

The CE-1000-4 card uses pluggable Gigabit Interface Converters (GBICs) to transport Ethernet traffic over a SONET network. The CE-1000-4 provides four IEEE 802.3-compliant, 1000-Mbps Gigabit Ethernet ports at the ingress. At the egress, the CE-1000-4 card provides an integrated Ethernet over SONET mapper with four virtual ports to transfer Ethernet packets over a SONET network.

The Ethernet ports automatically configure to operate at either half or full duplex and can determine whether to enable or disable flow control. The Ethernet ports can also be oversubscribed using flow control.

The Ethernet frames are encapsulated using the ITU-T generic framing procedure (GFP) (with or without CRC) or LEX, the point-to-point protocol (PPP) with high-level data link control (HDLC). The CE-1000-4 card can interoperate with G1000-4/G1K-4 cards (using LEX encapsulation), CE-100T-8 cards (using LEX or GFP-F), and ML-Series cards (using LEX or GFP-F).

The Ethernet frames can be mapped into:

- T1X1 G.707-based high-order virtual concatenated (HO VCAT) payloads
 - STS-3c-nv where n is 1 to 7
 - STS-1-nv where n is 1 to 21
- Contiguously concatenated (CCAT) SONET payloads
 - Standard CCAT sizes (STS-1, STS-3c, STS-12c, STS-24c, STS-48c)
 - Non-standard CCAT sizes (STS-6c, STS-9c, STS-18c).

To configure a CE-1000-4 card SONET STS or VCAT circuit, refer to the “Create Circuits and Tunnels” chapter in the *Cisco ONS 15454 Procedure Guide*.

The CE-1000-4 card provides multiple management options through Cisco Transport Controller (CTC), Cisco Transport Manager (CTM), Transaction Language 1 (TL1), and Simple Network Management Protocol (SNMP).

The CE-1000-4 card supports the software link capacity adjustment scheme (SW-LCAS). This makes it compatible with the ONS 15454 CE-100T-8 and ML-Series cards. The CE-1000-4 card supports VCAT groups (VCGs) that are reconfigurable when SW-LCAS is enabled (flexible VCGs). The CE-1000-4 card does not support the standard hardware-based LCAS.

The following guidelines apply to flexible VCGs:

- Members can be added or removed from VCGs.
- Members can be put into or out of service.
- Cross-connects can be added or removed from VCGs.
- Errored members will be automatically removed from VCGs.
- Adding or removing members from the VCG is service affecting.
- Adding or removing cross connects from the VCG is not service affecting if the associated members are not in group.

The CE-1000-4 card supports a non link capacity adjustment scheme (no-LCAS). This also makes it compatible with the ONS 15454 CE-100T-8 and ML-Series cards. The CE-1000-4 card supports VCAT groups (VCGs) that are fixed and not reconfigurable when no-LCAS is enabled (fixed VCGs).

The following guidelines apply to fixed VCGs:

- Members can be added or removed from VCGs using CTC or TL1.
- Members cannot be put into or out of service unless the force command mode is instantiated.



Note This is possible with CTC as it assumes the force command mode by default. However, to put members into or out of service using TL1, the force command mode must be set.

- Cross-connects can be added or removed from VCGs using CTC or TL1. This is service affecting as long as the VCG size (TXCOUNT) is not realigned with the loss of connections.

The CE-1000-4 card supports VCAT differential delay and provides these associated features:

- Supports a maximum VCG differential delay of 122 ms in each direction.
- Supports all protection schemes (path protection, two-fiber BLSR, four-fiber BLSR) on VCAT circuits that are split-fiber routed.
- Supports 2-fiber on VCAT circuits that are common-fiber routed.
- Differential delay compensation is automatically enabled on VCAT circuits that are diverse (split fiber) routed and disabled on VCAT circuits that are common-fiber routed.

Figure 5-11 shows the CE-1000-4 card faceplate and block diagram.

Figure 5-11 CE-1000-4 Faceplate and Block Diagram

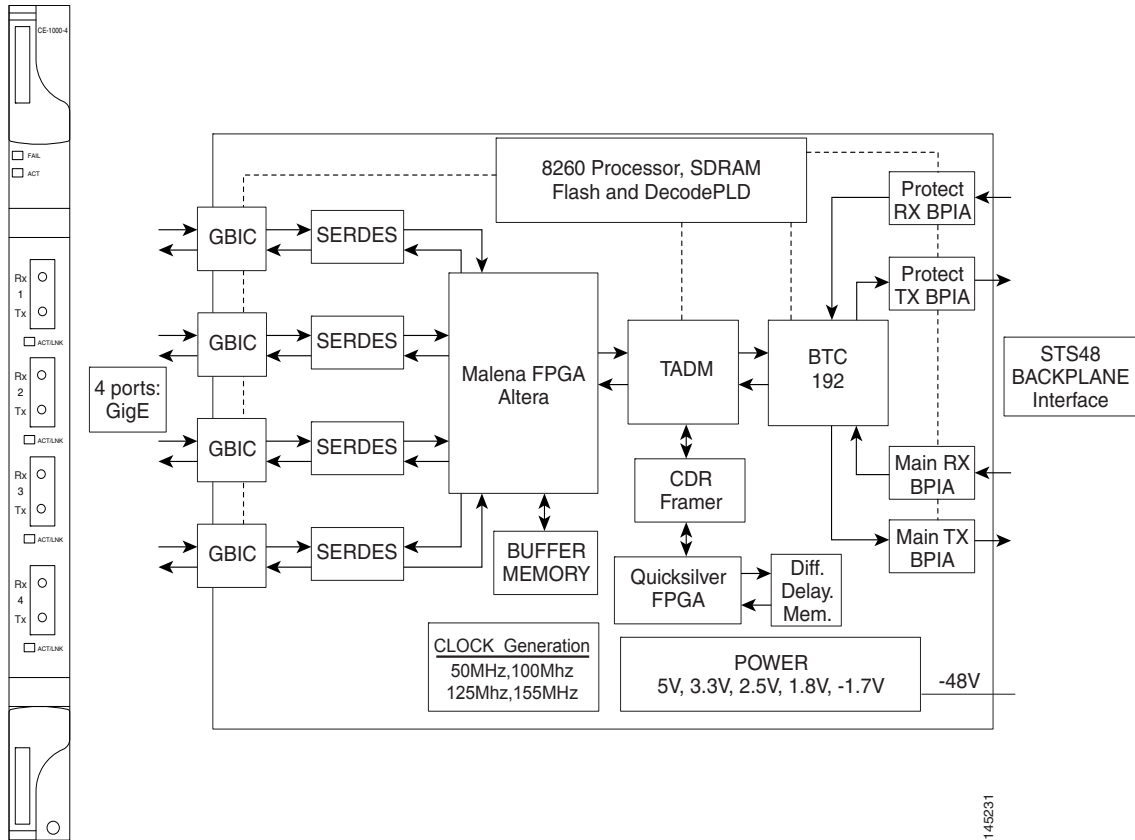

5.12.1 CE-1000-4 Card-Level Indicators

The CE-1000-4 card faceplate has two card-level LED indicators, described in [Table 5-23](#).

Table 5-23 CE-1000-4 Card-Level Indicators

Card-Level LEDs	Description
FAIL LED (Red)	The red FAIL LED indicates that the card processor is not ready or that a catastrophic software failure occurred on the CE-1000-4 card. As part of the boot sequence, the FAIL LED is turned on until the software deems the card operational.
ACT LED (Green)	The green ACT LED provides the operational status of the CE-1000-4 card. When the ACT LED is green, it indicates that the CE-1000-4 card is active and the software is operational.



Note

If the CE-1000-4 card is inserted in a slot that has been preprovisioned for a different type of card, the red FAIL LED and the green ACT LED will flash alternately until the configuration mismatch is resolved.

5.12.2 CE-1000-4 Port-Level Indicators

The CE-1000-4 card provides a pair of LEDs for each Gigabit Ethernet port: an amber LED for activity (ACT) and a green LED for link status (LINK). [Table 5-24](#) describes the status that each color represents.

Table 5-24 CE-1000-4 Port-Level Indicators

Port-Level Indicators	Description
Off	No link exists to the Ethernet port.
Steady amber	A link exists to the Ethernet port, but traffic flow is inhibited. For example, a lack of circuit setup, an error on the line, or a disabled port might inhibit traffic flow.
Solid green	A link exists to the Ethernet port, but no traffic is carried on the port.
Flashing green	A link exists to the Ethernet port, and traffic is carried on the port. The LED flash rate reflects the traffic rate for that port.

5.12.3 Cross-Connect and Slot Compatibility

The CE-1000-4 card can be installed in Slots 1 to 6 and 12 to 17 when used with the XC10G and XC-VXC-10G cards. When the shelf uses the XCVT card, the CE-1000-4 card can only be installed in Slots 5, 6, 12, and 13.

5.13 Ethernet Card GBICs and SFPs

This section describes the GBICs and SFPs used with the Ethernet cards.

The ONS 15454 Ethernet cards use industry standard small form-factor pluggable connectors (SFPs) and gigabit interface converter (GBIC) modular receptacles. The ML-Series Gigabit Ethernet cards use standard Cisco SFPs. The Gigabit E-Series, G-1K-4, and CE-1000-4 cards use standard Cisco GBICs. With Software Release 4.1 and later, G-Series cards can also be equipped with dense wavelength division multiplexing (DWDM) and coarse wavelength division multiplexing (CWDM) GBICs to function as Gigabit Ethernet transponders.

For all Ethernet cards, the type of GBIC or SFP plugged into the card is displayed in CTC and TL1. Cisco offers SFPs and GBICs as separate orderable products.

5.13.1 Compatibility by Card

[Table 5-25](#) lists Cisco ONS 15454 Ethernet cards with their compatible GBICs and SFPs.



Caution

Use only GBICs and SFPs certified for use in Cisco Optical Networking Systems. The top assembly numbers (TANs) for each GBIC and SFP are provided in [Table 5-25](#).

Table 5-25 GBIC and SFP Card Compatibility

Card	Compatible GBIC or SFP (Cisco Product ID)	Cisco Top Assembly Number (TAN)
E1000-2-G (ONS 15454 SONET)	15454-GBIC-SX	30-0759-01
E1000-2 (ONS 15454 SONET/SDH)	15454E-GBIC-SX 15454-GBIC-LX/LH 15454E-GBIC-LX/LH	800-06780-01 ¹ 10-1743-01 30-0703-01
G1K-4 (ONS 15454 SONET/SDH)	15454-GBIC-SX	30-0759-01
G1000-4 (ONS 15454 SONET/SDH)	15454E-GBIC-SX 15454-GBIC-LX/LH 15454E-GBIC-LX/LH 15454-GBIC-ZX 15454E-GBIC-ZX 15454-GBIC-xx.x ² 15454E-GBIC-xx.x ² 15454-GBIC-xxxx ³ 15454E-GBIC-xxxx ³	800-06780-01 10-1743-01 30-0703-01 30-0848-01 10-1744-01 10-1845-01 through 10-1876-01 10-1845-01 through 10-1876-01 10-1453-01 through 10-1460-01 10-1453-01 through 10-1460-01
ML1000-2 (ONS 15454 SONET/SDH)	15454-SFP-LC-SX 15454E-SFP-LC-SX ONS-SC-GE-SX 15454-SFP-LC-LX/LH 15454E-SFP-LC-LX/LH ONS-SC-GE-LX	30-1301-01 30-1301-01 10-2301-01 30-1299-01 30-1299-01 10-2298-01
ML100X-8 (ONS 15454 SONET/SDH)	ONS-SE-100-FX ONS-SE-100-LX10	10-2212-01 10-2213-01
CE-1000-4 (ONS 15454 SONET/SDH)	15454-GBIC-SX 15454-GBIC-LX 15454-GBIC-ZX ONS-GC-GE-SX ONS-GC-GE-LX ONS-GC-GE-ZX	30-0759-01 10-1743-01 30-0848-01 10-2192-01 10-2191-01 10-2190-01

1. This TAN is only compatible with ONS 15454-E1000-2 or 15454-E1000-2-G cards.
2. xx.x defines the 32 possible wavelengths [Table 5-27 on page 5-34](#).
3. xxxx defines the 8 possible wavelengths as shown in [Table 5-26 on page 5-33](#).

5.13.2 GBIC Description

GBICs are integrated fiber optic transceivers that provide high-speed serial links from a port or slot to the network. Various latching mechanisms can be utilized on the GBIC pluggable modules. There is no correlation between the type of latch and the model type (such as SX or LX/LH) or technology type (such as Gigabit Ethernet). See the label on the GBIC for technology type and model. One GBIC model has two clips (one on each side of the GBIC) that secure the GBIC in the slot on the Ethernet card; the other has a locking handle. Both types are shown in [Figure 5-12](#).

GBIC dimensions are:

- Height 0.39 in. (1 cm)
- Width 1.18 in. (3 cm)

- Depth 2.56 in. (6.5 cm)

GBIC temperature ranges are:

- COM—commercial operating temperature range -5°C to 70°C
- EXT—extended operating temperature range 0°C to 85°C
- IND—industrial operating temperature range -40°C to 85°C

Figure 5-12 GBICs with Clips (left) and with a Handle (right)

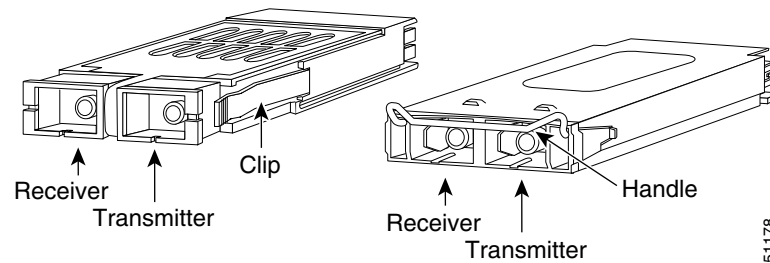

5.13.3 G-1K-4 DWDM and CWDM GBICs

DWDM (15454-GBIC-xx.x, 15454E-GBIC-xx.x) and CWDM (15454-GBIC-xxxx, 15454E-GBIC-xxxx) GBICs operate in an ONS 15454 G-Series card when the card is configured in Gigabit Ethernet Transponding mode or in Ethernet over SONET mode. DWDM and CWDM GBICs are both wavelength division multiplexing (WDM) technologies and operate over single-mode fibers with SC connectors. Cisco CWDM GBIC technology uses a 20 nm wavelength grid and Cisco ONS 15454 DWDM GBIC technology uses a 1 nm wavelength grid. CTC displays the specific wavelengths of the installed CWDM or DWDM GBICs. DWDM wavelengths are spaced closer together and require more precise lasers than CWDM. The DWDM spectrum allows for optical signal amplification. For more information on G-Series card transponding mode, refer to the *Ethernet Card Software Feature and Configuration Guide for the Cisco ONS 15454, Cisco ONS 15454 SDH, and Cisco ONS 15327*.

The DWDM and CWDM GBICs receive across the full 1300 nm and 1500 nm bands, which includes all CWDM, DWDM, LX/LH, ZX wavelengths, but transmit on one specified wavelength. This capability can be exploited in some of the G-Series transponding modes by receiving wavelengths that do not match the specific transmission wavelength.



Note

G1000-4 cards support CWDM and DWDM GBICs. G1K-4 cards with the Common Language Equipment Identification (CLEI) code of WM5IRWPCAA (manufactured after August 2003) support CWDM and DWDM GBICs. G1K-4 cards manufactured prior to August 2003 do not support CWDM or DWDM GBICs.

The ONS 15454-supported CWDM GBICs reach up to 100 to 120 km over single-mode fiber and support eight wavelengths as shown in [Table 5-26](#).

Table 5-26 Supported Wavelengths for CWDM GBICs

CWDM GBIC Wavelengths	1470 nm	1490 nm	1510 nm	1530 nm	1550 nm	1570 nm	1590 nm

Table 5-26 Supported Wavelengths for CWDM GBICs

Corresponding GBIC Colors	Gray	Violet	Blue	Green	Yellow	Orange	Red	Br
Band	47	49	51	53	55	57	59	61

The ONS 15454-supported DWDM GBICs reach up to 100 to 120 km over single-mode fiber and support 32 different wavelengths in the red and blue bands. Paired with optical amplifiers, such as the Cisco ONS 15216, the DWDM GBICs allow maximum unregenerated spans of approximately 300 km (Table 5-27).

Table 5-27 Supported Wavelengths for DWDM GBICs

Blue Band	1530.33 nm	1531.12 nm	1531.90 nm	1532.68 nm	1534.25 nm	1535.04 nm	1535.82 nm	1536.61 nm
	1538.19 nm	1538.98 nm	1539.77 nm	1540.56 nm	1542.14 nm	1542.94 nm	1543.73 nm	1544.53 nm
Red Band	1546.12 nm	1546.92 nm	1547.72 nm	1548.51 nm	1550.12 nm	1550.92 nm	1551.72 nm	1552.52 nm
	1554.13 nm	1554.94 nm	1555.75 nm	1556.55 nm	1558.17 nm	1558.98 nm	1559.79 nm	1560.61 nm

CWDM or DWDM GBICs for the G-Series card come in set wavelengths and are not provisionable. The wavelengths are printed on each GBIC, for example, CWDM-GBIC-1490. The user must insert the specific GBIC transmitting the wavelength required to match the input of the CWDM/DWDM device for successful operation (Figure 5-13). Follow your site plan or network diagram for the required wavelengths.

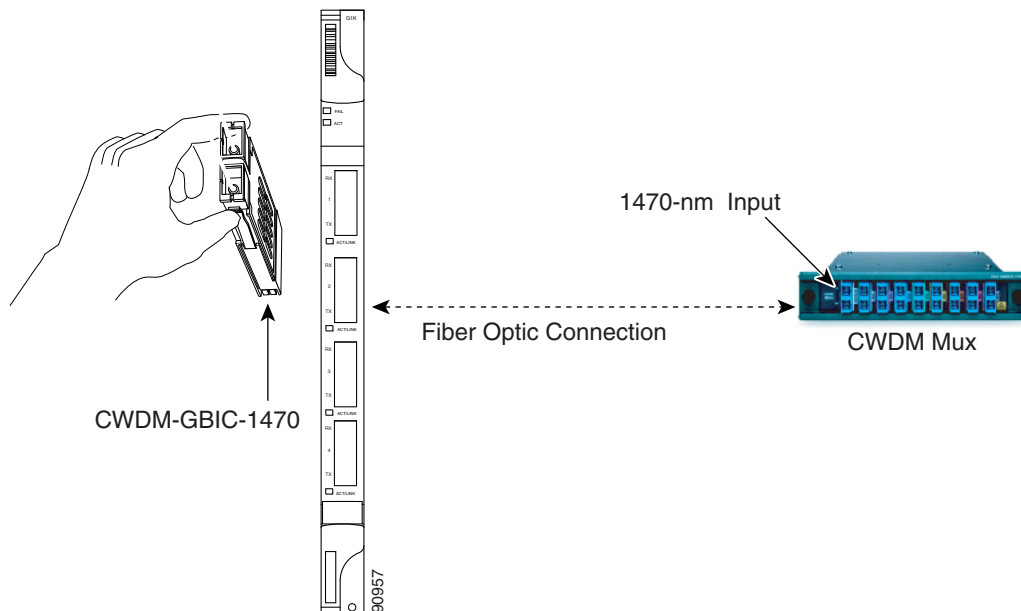
Figure 5-13 CWDM GBIC with Wavelength Appropriate for Fiber-Connected Device

A G-Series card equipped with CWDM or DWDM GBICs supports the delivery of unprotected Gigabit Ethernet service over Metro DWDM (Figure 5-14). It can be used in short-haul and long-haul applications.

Figure 5-14 G-Series with CWDM/DWDM GBICs in Cable Network

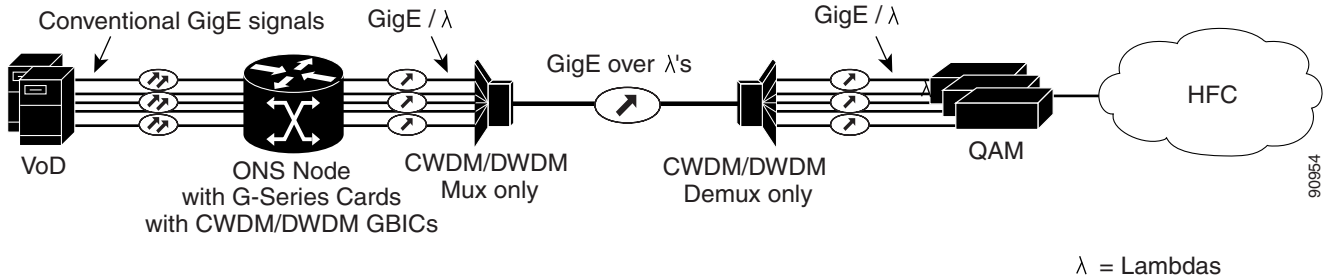

5.13.4 SFP Description

SFPs are integrated fiber-optic transceivers that provide high-speed serial links from a port or slot to the network. Various latching mechanisms can be utilized on the SFP modules. There is no correlation between the type of latch and the model type (such as SX or LX/LH) or technology type (such as Gigabit Ethernet). See the label on the SFP for technology type and model. One type of latch available is a mylar tab (Figure 5-15), a second type of latch available is an actuator/button (Figure 5-16), and a third type of latch is a bail clasp (Figure 5-17).

SFP dimensions are:

- Height 0.03 in. (8.5 mm)
- Width 0.53 in. (13.4 mm)
- Depth 2.22 in. (56.5 mm)

SFP temperature ranges for are:

- COM—commercial operating temperature range -5°C to 70°C
- EXT—extended operating temperature range -5°C to 85°C
- IND—industrial operating temperature range -40°C to 85°C

Figure 5-15 Mylar Tab SFP

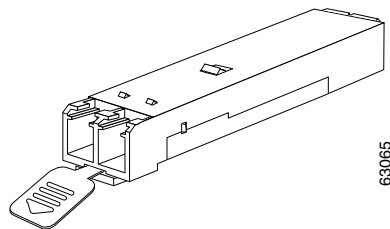
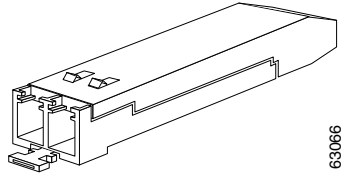
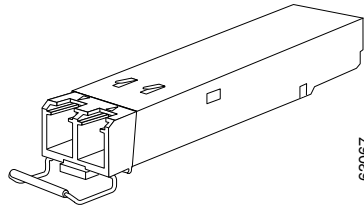

Figure 5-16 Actuator/Button SFP



63066

Figure 5-17 Bail Clasp SFP



63067



CHAPTER 6

Storage Access Networking Cards



Note

The terms "Unidirectional Path Switched Ring" and "UPSR" may appear in Cisco literature. These terms do not refer to using Cisco ONS 15xxx products in a unidirectional path switched ring configuration. Rather, these terms, as well as "Path Protected Mesh Network" and "PPMN," refer generally to Cisco's path protection feature, which may be used in any topological network configuration. Cisco does not recommend using its path protection feature in any particular topological network configuration.

The Fibre Channel Multirate 4-Port (FC_MR-4) card is a 1.0625- or 2.125-Gbps Fibre Channel/fiber connectivity (FICON) card that integrates non-SONET framed protocols into a SONET time-division multiplexing (TDM) platform through virtually concatenated payloads. For installation and step-by-step circuit configuration procedures, refer to the *Cisco ONS 15454 Procedure Guide*.

Chapter topics include:

- [6.1 FC_MR-4 Card Overview, page 6-1](#)
- [6.2 FC_MR-4 Card Modes, page 6-4](#)
- [6.3 FC_MR-4 Card Application, page 6-7](#)
- [6.4 FC_MR-4 Card GBICs, page 6-8](#)

6.1 FC_MR-4 Card Overview



Note

For hardware specifications, see the [“A.8.1 FC_MR-4 Card Specifications”](#) section on page A-49.

The FC_MR-4 card uses pluggable Gigabit Interface Converters (GBICs) to transport non-SONET/SDH-framed, block-coded protocols over SONET/SDH. The FC_MR-4 enables four client Fibre Channel (FC) ports to be transported over SONET/SDH, encapsulating the frames using the ITU-T generic framing procedure (GFP) format and mapping them into either T1X1 G.707-based virtual concatenated (VCAT) payloads or standard contiguously concatenated SONET payloads. The FC_MR-4 card has the following features:

- Four FICON ports operating at 1 Gbps or 2 Gbps
 - All four ports can be operational at any time due to subrate support
 - Advanced distance extension capability (buffer-to-buffer credit spoofing)
- Pluggable GBIC optics

- Dual rate (1G/2G): MM (550 m) and SM (10 km)
- Single rate (1G): SX (550 m) and LX (10 km)
- SONET/SDH support
 - Four 1.0625-Gbps FC channels can be mapped into one of the following:
 - SONET containers as small as STS1-1v (subrate)
 - SDH containers as small as VC4-1v (subrate)
 - SONET/SDH containers as small as STS-18c/VC4-6v (full rate)
 - Four 2.125-Gbps FC channels can be mapped into one of the following:
 - SONET containers as small as STS1-1v (subrate)
 - SDH containers as small as VC4-1v (subrate)
 - SONET/SDH containers as small as STS-36c/VC4-12v (full rate)
- Frame encapsulation: ITU-T G.7041 transparent generic framing procedure (GFP-T)
- High-order SONET/SDH VCAT support (STS1-Xv and STS-3c-Xv/VC4-Xv)
- Differential delay support for VCAT circuits

Figure 6-1 shows the FC_MR-4 faceplate and block diagram.

Figure 6-1 FC_MR-4 Faceplate and Block Diagram

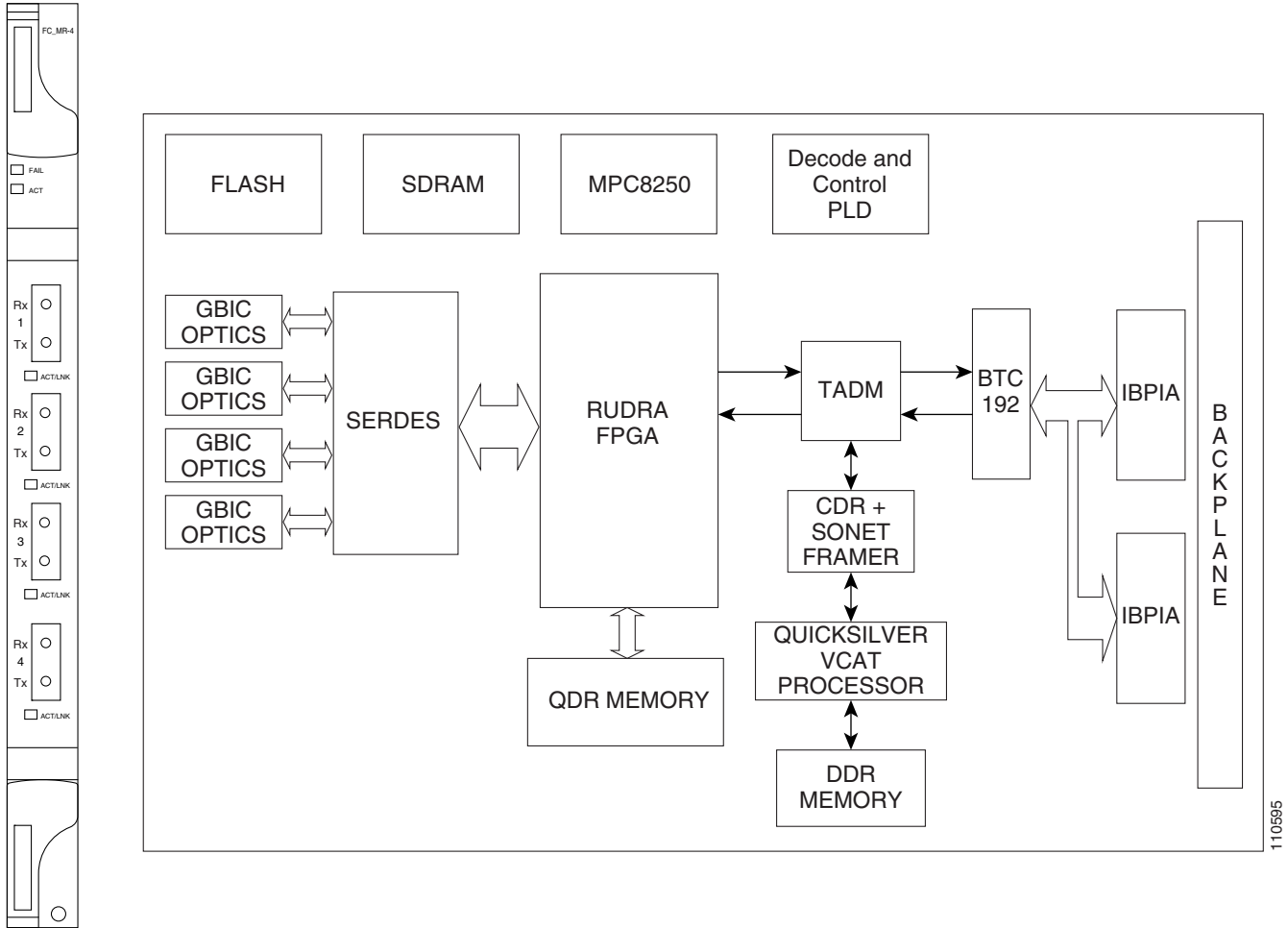

6.1.1 FC_MR-4 Card-Level Indicators

Table 6-1 describes the two card-level LEDs on the FC_MR-4 card.

Table 6-1 FC_MR-4 Card-Level Indicators

Card-Level Indicators	Description
FAIL LED (Red)	The red FAIL LED indicates that the card processor is not ready. Replace the card if the red FAIL LED persists.
ACT LED (Green)	If the ACT/STBY LED is green, the card is operational and ready to carry traffic.
ACT LED (Amber)	If the ACT/STBY LED is amber, the card is rebooting.

6.1.2 FC_MR-4 Port-Level Indicators

Each FC_MR-4 port has a corresponding ACT/LNK LED. The ACT/LNK LED is solid green if the port is available to carry traffic, is provisioned as in-service, and is in the active mode. The ACT/LNK LED is flashing green if the port is carrying traffic. The ACT/LNK LED is steady amber if the port is not enabled and the link is connected, or if the port is enabled and the link is connected but there is a SONET/SDH transport error. The ACT/LNK LED is not lit if there is no link.

You can find the status of the card ports using the LCD screen on the ONS 15454 SDH fan-tray assembly. Use the LCD to view the status of any port or card slot; the screen displays the number and severity of alarms for a given port or slot. Refer to the *Cisco ONS 15454 Troubleshooting Guide* for a complete description of the alarm messages.

6.1.3 FC_MR-4 Compatibility

The FC_MR-4 cards can be installed in Slots 1 to 6 and 12 to 17 when used with the XC10G and XC-VXC-10G cards. When the shelf uses the XCVT card, the FC_MR-4 can be used in only the high-speed (slots 5/6 and 12/13).

The FC_MR-4 card can be provisioned as part of any valid ONS 15454 SONET/SDH network topology, such as a path protection, bidirectional line switched ring (BLSR), or linear network topologies. The FC_MR-4 card is compatible with Software Release 4.6 and greater.

6.2 FC_MR-4 Card Modes

The FC_MR-4 card can operate in two different modes:

- Line rate mode—This mode is backward compatible with the Software R4.6 Line Rate mode.
- Enhanced mode—This mode supports subrate, distance extension, differential delay, and other enhancements.

The FC_MR-4 card reboots when a card mode changes (a traffic hit results). The Field Programmable Gate Array (FPGA) running on the card upgrades to the required image. However, the FPGA image in the card's flash memory is not modified.

6.2.1 Line-Rate Card Mode

The mapping for the line rate card mode is summarized here.

- 1 Gbps Fibre Channel/FICON is mapped into:
 - STS-24c, STS-48c
 - VC4-8c, VC4-16c
 - STS1-Xv where X is 19 to 24
 - STS3c-Xv where X is 6 to 8
 - VC4-Xv where X is 6 to 8
- 2 Gbps Fibre Channel/FICON is mapped into:
 - STS-48c
 - VC4-16c

- STS-1-Xv where X is 37 to 48
- STS-3c-Xv where X is 12 to 16
- VC4-Xv where X is 12 to 16

6.2.2 Enhanced Card Mode

The features available in enhanced card mode are given in this section.

6.2.2.1 Mapping

1 Gbps Fibre Channel/FICON is mapped into:

- STS-1, STS-3c, STS-6c, STS-9c, STS-12c, STS-18c, STS-24c, STS-48c
- VC4-1c, VC4-2c, VC4-3c, VC4-4c, VC4-6c, VC4-8c, VC4-16c
- STS-1-Xv where X is 1 to 24
- STS-3c-Xv where X is 1 to 8
- VC4-Xv where X is 1 to 8

2 Gbps Fibre Channel/FICON is mapped into:

- STS-1, STS-3c, STS-6c, STS-9c, STS-12c, STS-18c, STS-24c, STS-36c, STS-48c
- VC4-1c, VC4-2c, VC4-3c, VC4-4c, VC4-6c, VC4-8c, VC4-12c, VC4-16c
- STS-1-Xv where X is 1 to 48
- STS-3c-Xv where X is 1 to 16
- VC4-Xv where X is 1 to 16

6.2.2.2 SW -LCAS

VCAT group (VCG) is reconfigurable when the software link capacity adjustment scheme (SW-LCAS) is enabled, as follows:

- Out-of-service (OOS) and out-of-group (OOG) members can be removed from VCG
- Members with deleted cross-connects can be removed from VCGs
- Errored members can be autonomously removed from VCGs
- Degraded bandwidth VCGs are supported
- VCG is flexible with SW-LCAS enabled (VCG can run traffic as soon as the first cross-connect is provisioned on both sides of the transport)

6.2.2.3 Distance Extension

This following list describes the FC_MR-4 card distance extension capabilities:

- Enabling of a storage access networking (SAN) extension over long distances through buffer-to-buffer (B2B) credit spoofing.
 - 2300 km for 1G ports (longer distances supported with lesser throughput)
 - 1150 km for 2G ports (longer distances supported with lesser throughput)

- Negotiation mechanism to identify whether a far-end FC-over-SONET card supports the Cisco proprietary B2B mechanism
- Auto detection of FC switch B2B credits from FC-SW standards-based exchange link parameters (ELP) frames
- Support for manual provisioning of credits based on FC switch credits
- Automatic GFP buffers adjustment based on roundtrip latency between two SL ports
- Automatic credits recovery during SONET switchovers/failures
- Insulation for FC switches from any SONET switchovers; no FC fabric reconvergences for SONET failures of less than or equal to 60 ms

6.2.2.4 Differential Delay Features

The combination of VCAT, SW-LCAS, and GFP specifies how to process information for data and storage clients. The resulting operations introduce delays. Their impact depends on the type of service being delivered. For example, storage requirements call for very low latency, as opposed to traffic such as e-mail where latency variations are not critical.

With VCAT, SONET paths are grouped to aggregate bandwidth to form VCGs. Because each VCG member can follow a unique physical route through a network, there are differences in propagation delay, and possibly processing delays between members. The overall VCG propagation delay corresponds to that of the slowest member. The VCAT differential delay is the relative arrival time measurement between members of a VCG. The FC_MR-4 card is able to handle VCAT differential delay and provides these associated features:

- Supports a maximum of 122 ms of delay difference between the shortest and longest paths.
- Supports diverse fiber routing for VCAT circuit.
- All protection schemes are supported (path protection, automatic protection switching [APS], 2-fiber BLSR, 4-fiber BLSR).
- Supports routing of VCAT group members through different nodes in the SONET network.
- Differential delay compensation is automatically enabled on VCAT circuits that are diverse (split fiber) routed, and disabled on VCAT circuits that are common fiber routed.



Note

Differential delay support for VCAT circuits is supported by means of a TL1 provisioning parameter (EXTBUFFERS) in the ENT-VCG command.

6.2.2.5 Interoperability Features

The interoperability features are as follows:

- Maximum frame size setting to prevent accumulation of oversized performance monitoring parameters for virtual SAN (VSAN) frames
- Ingress filtering disable for attachment to third-party GFP-over-SONET/SDH equipment

6.2.3 Link Integrity

The link integrity features are as follows:

- Data port disabled if upstream data port is not able to send over SONET/SDH transport

- Data port disabled if SONET/SDH transport is errored

6.2.4 Link Recovery

Link recovery has the following features:

- Reduces the impact of SONET/SDH disruptions on attached Fibre Channel equipment
- Speeds up the recovery of Inter-Switch Links (ISLs)
- Allows monitoring of B2B credit depletion due to SONET outage and full recovery of the credits, thus preventing the slow decay of bandwidth/throughput



Note

Distance extension and link recovery cannot be enabled at the same time.

6.3 FC_MR-4 Card Application

The FC_MR-4 card reliably transports carrier-class, private-line Fibre Channel/FICON transport service. Each FC_MR-4 card can support up to four 1-Gbps circuits or four 2-Gbps circuits. Four 1.0625-Gbps FC channels can be mapped into containers as small as STS-1 (subrate), with a minimum of STS-18c/VC4-6v for full rate. Four 2.125-Gbps FC channels can be mapped into containers as small as STS-1 (sub-rate), with a minimum of STS-36c/VC4-12v for full rate.

The FC_MR-4 card incorporates features optimized for carrier-class applications such as:

- Carrier-class Fibre Channel/FICON
- 50 ms of switch time through SONET/SDH protection as specified in Telcordia GR-253-CORE



Note

Protection switch traffic hit times of less than 60 ms are not guaranteed with differential delay in effect.

- Hitless software upgrades



Note

Hitless software upgrades are not possible with an activation from Software R5.0 to Software R6.0 or higher in enhanced card mode. This is because the FPGA must be upgraded to support differential delay in enhanced mode. Upgrades are still hitless with the line rate mode.

- Remote Fibre Channel/FICON circuit bandwidth upgrades through integrated Cisco Transport Controller (CTC)
- Multiple management options through CTC, Cisco Transport Manager (CTM), TL1, and Simple Network Management Protocol (SNMP)
- Differential delay compensation of up to 122 ms for diversely routed VCAT circuits

The FC_MR-4 payloads can be transported over the following protection types:

- path protection
- BLSR
- Unprotected
- Protection channel access (PCA)

The FC_MR-4 payloads can be transported over the following circuit types:

- STS
- STSn
- STS-V



Note

Virtual Tributary (VT) and VT-V circuits are not supported.

The FC_MR-4 card supports VCAT. See the “[11.17 Virtual Concatenated Circuits](#)” section on [page 11-33](#) for more information about VCAT circuits.

6.4 FC_MR-4 Card GBICs

The FC_MR-4 uses pluggable GBICs for client interfaces. [Table 6-2](#) lists GBICs that are compatible with the FC_MR-4 card. See the “[5.13.2 GBIC Description](#)” section on [page 5-32](#) for more information.

Table 6-2 GBIC Compatibility

Card	Compatible GBIC or SFP (Cisco Product ID)	Cisco Top Assembly Number (TAN)
FC_MR-4 (ONS 15454 SONET/SDH)	15454-GBIC-SX	30-0759-01
	15454E-GBIC-SX	800-06780-01
	15454-GBIC-LX/LH	10-1743-01
	15454E-GBIC-LX/LH	30-0703-01
	ONS-GX-2FC-MMI	10-2015-01
	ONS-GX-2FC-SML	10-2016-01



CHAPTER 7

Card Protection

This chapter explains the Cisco ONS 15454 card protection configurations. To provision card protection, refer to the *Cisco ONS 15454 Procedure Guide*.

Chapter topics include:

- [7.1 Electrical Card Protection, page 7-1](#)
- [7.2 Electrical Card Protection and the Backplane, page 7-5](#)
- [7.3 OC-N Card Protection, page 7-13](#)
- [7.4 Unprotected Cards, page 7-14](#)
- [7.5 External Switching Commands, page 7-14](#)

7.1 Electrical Card Protection

The ONS 15454 provides a variety of electrical card protection methods. This section describes the protection options. [Figure 7-1](#) shows a 1:1 protection configuration and [Figure 7-2 on page 7-3](#) shows a 1:N protection configuration.

This section covers the general concept of electrical card protection. Specific electrical card protection schemes depend on the type of electrical card as well as the electrical interface assembly (EIA) type used on the ONS 15454 backplane. [Table 7-4 on page 7-6](#) details the specific electrical card protection schemes.



Note

See [Table 1-1 on page 1-15](#) and [Table 1-2 on page 1-16](#) for the EIA types supported by the 15454-SA-ANSI and 15454-SA-HD (high-density) shelf assemblies.



Caution

When a protection switch moves traffic from the working/active electrical card to the protect/standby electrical card, ports on the new active/standby card cannot be placed out of service as long as traffic is switched. Lost traffic can result when a port is taken out of service, even if the standby card no longer carries traffic.

7.1.1 1:1 Protection

In 1:1 protection, a working card is paired with a protect card of the same type. If the working card fails, the traffic from the working card switches to the protect card. You can provision 1:1 to be revertive or nonrevertive. If revertive, traffic automatically reverts to the working card after the failure on the working card is resolved. [Figure 7-1](#) shows an example of the ONS 15454 in a 1:1 protection configuration. Each working card in an even-numbered slot is paired with a protect card in an odd-numbered slot: Slot 1 is protecting Slot 2, Slot 3 is protecting Slot 4, Slot 5 is protecting Slot 6, Slot 17 is protecting Slot 16, Slot 15 is protecting Slot 14, and Slot 13 is protecting Slot 12.

Figure 7-1 Example: ONS 15454 Cards in a 1:1 Protection Configuration (SMB EIA)

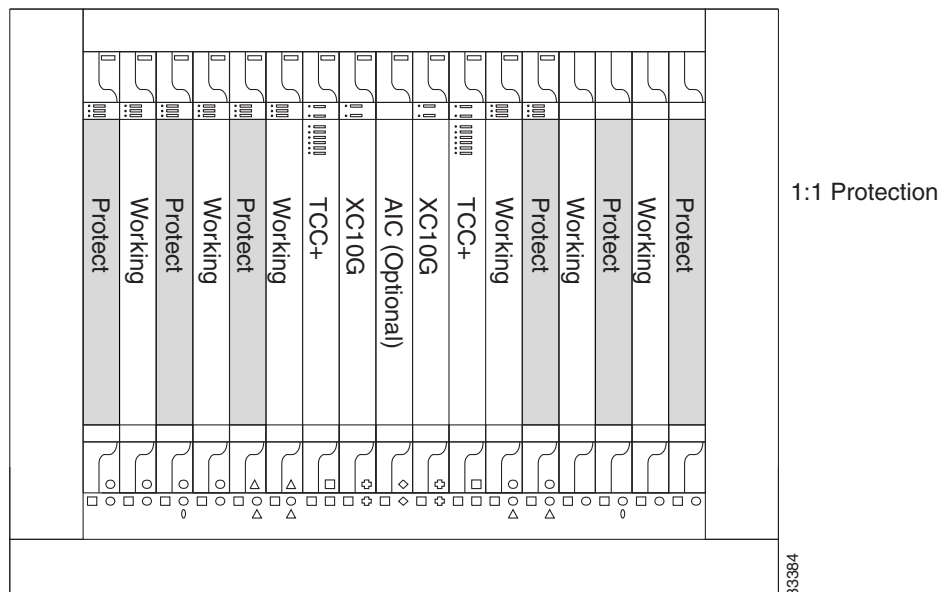

[Table 7-1](#) provides supported 1:1 protection by electrical card type.

Table 7-1 Supported 1:1 Protection by Electrical Card

Working Card	Protect Card	Working Slot	Protection Slot
DS1-14 or DS1N-14	DS1-14 or DS1N-14	2	1
DS3-12/DS3-12E or DS3N-12/DS3N-12E	DS3-12 or DS3N-12	4	3
DS3i-N-12	DS3i-N-12	6	5
DS3XM-6 (Transmux)	DS3XM-6 (Transmux)	12	13
DS3XM-12 (Transmux)	DS3XM-12 (Transmux)	14	15
		16	17

7.1.2 1:N Protection

1:N protection allows a single electrical card to protect up to five working cards of the same speed. 1:N cards have added circuitry to act as the protect card in a 1:N protection group. Otherwise, the card is identical to the standard card and can serve as a normal working card.

The physical DS-1 or DS-3 interfaces on the ONS 15454 backplane use the working card until the working card fails. When the node detects this failure, the protect card takes over the physical DS-1 or DS-3 electrical interfaces through the relays and signal bridging on the backplane. Figure 7-2 shows the ONS 15454 in a 1:N protection configuration. Each side of the shelf assembly has only one card protecting all of the cards on that side.

Figure 7-2 Example: ONS 15454 Cards in a 1:N Protection Configuration (SMB EIA)

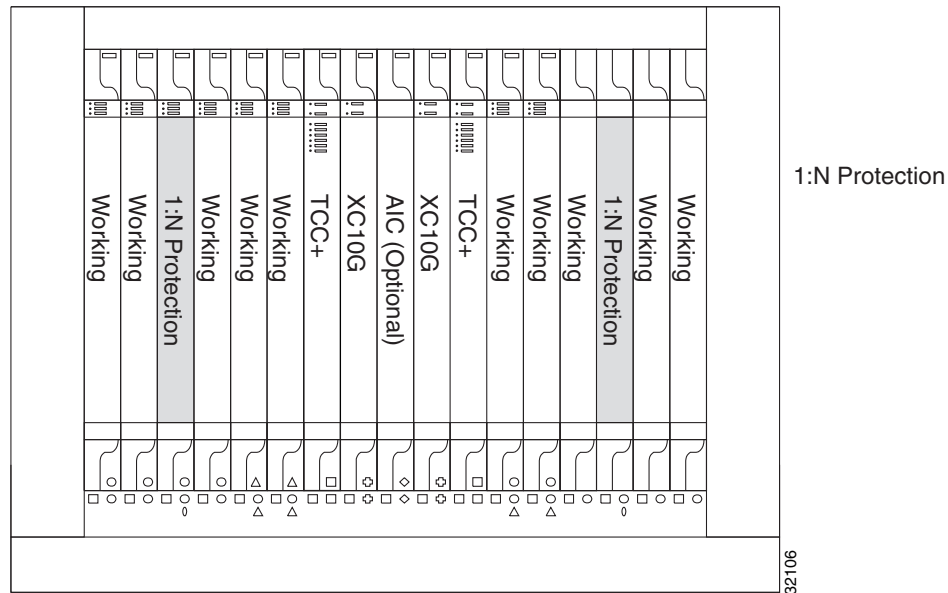

Table 7-2 provides the supported 1:N configurations by electrical card, as well as the card types that can be used for working and protection cards. Additional engineering rules for 1:N card deployments will be covered in the following sections.

Table 7-2 Supported 1:N Protection by Electrical Card

Working Card	Protect Card	Protect Group (Maximum)	Working Slot	Protection Slot
DS1-14 or DS1N-14	DS1N-14	$N \leq 5$	1, 2, 4, 5, 6	3
			12, 13, 14, 16, 17	15
DS1/E1-56	DS1/E1-56	$N \leq 2$	1 ¹ , 2 ²	3
			16 ³ , 17 ⁴	15
DS3-12/DS3-12E or DS3N-12/DS3N-12E	DS3N-12/DS3N-12E	$N \leq 5$	1, 2, 4, 5, 6	3
			12, 13, 14, 16, 17	15
DS3i-N-12	DS3i-N-12	$N \leq 5$	1, 2, 4, 5, 6	3
			12, 13, 14, 16, 17	15

Table 7-2 Supported 1:N Protection by Electrical Card (continued)

Working Card	Protect Card	Protect Group (Maximum)	Working Slot	Protection Slot
DS3/EC1-48	DS3/EC1-48	$N \leq 2$	1 ⁵ , 2 ⁶	3
			16 ⁷ , 17 ⁸	15
DS3XM-12 (Transmux)	DS3XM-12 (Transmux)	$N \leq 5$	1, 2, 4, 5, 6	3
			12, 13, 14, 16, 17	15
DS3XM-12 (Transmux)	DS3XM-12 (Transmux)	$N \leq 7$ (portless ⁹)	1, 2, 4, 5, 6, 12, 13, 14, 15, 16, 17	3
			1, 2, 3, 4, 5, 6, 12, 13, 14, 16, 17	15

1. A high-density electrical card inserted in Slot 1 restricts the use of Slots 5 and 6 to optical, data, or storage cards.
2. A high-density electrical card inserted in Slot 2 restricts the use of Slots 4 and 6 to optical, data, or storage cards.
3. A high-density electrical card inserted in Slot 16 restricts the use of Slot 14 to optical, data, or storage cards.
4. A high-density electrical card inserted in Slot 17 restricts the use of Slots 12 and 13 to optical, data, or storage cards.
5. A high-density electrical card inserted in Slot 1 restricts the use of Slots 5 and 6 to optical, data, or storage cards.
6. A high-density electrical card inserted in Slot 2 restricts the use of Slots 4 and 6 to optical, data, or storage cards.
7. A high-density electrical card inserted in Slot 16 restricts the use of Slot 14 to optical, data, or storage cards.
8. A high-density electrical card inserted in Slot 17 restricts the use of Slots 12 and 13 to optical, data, or storage cards.
9. Portless DS-3 Transmux operation does not terminate the DS-3 signal on the EIA panel.

7.1.2.1 Revertive Switching

1:N protection supports revertive switching. Revertive switching sends the electrical interfaces (traffic) back to the original working card after the card comes back online. Detecting an active working card triggers the reversion process. There is a variable time period for the lag between detection and reversion, called the revertive delay, which you can set using the ONS 15454 software, Cisco Transport Controller (CTC). To set the revertive delay, refer to the “Turn Up a Node” chapter in the *Cisco ONS 15454 Procedure Guide*. All cards in a protection group share the same reversion settings. 1:N protection groups default to automatic reversion.



Caution

A user-initiated switch (external switching command) overrides the revertive delay, that is, clearing the switch clears the timer.

7.1.2.2 1:N Protection Guidelines

There are two types of 1:N protection groups for the ONS 15454: ported and portless. Ported 1:N interfaces are the traditional protection groups for signals electrically terminated on the shelf assembly. Portless 1:N interfaces are signals received through an electrical synchronous transport signal (STS) through the cross-connect card. The DS3XM-12 card supports portless as well as traditional ported deployments. [Table 7-2 on page 7-3](#) outlines the 1:N configurations supported by each electrical card type.

The following rules apply to ported 1:N protection groups in the ONS 15454:

- Working and protect card groups must reside in the same card bank (Side A or Side B).
- The 1:N protect card must reside in Slot 3 for Side A and Slot 15 for Side B.

- Working cards can sit on either or both sides of the protect card.

The following rules apply to portless 1:N protection groups in the ONS 15454:

- Working and protect card groups can reside in the same card bank or different card banks (Side A or Side B).
- The 1:N protect card can be installed in either Slot 3 or Slot 15 and protect working cards in both card banks.
- Working cards can sit on either or both sides of the protect card.

The ONS 15454 supports 1:N equipment protection for all add-drop multiplexer (ADM) configurations (ring, linear, and terminal), as specified by Telcordia GR-253-CORE. For detailed procedures for setting up DS-1 and DS-3 protection groups, refer to the *Cisco ONS 15454 Procedure Guide*.

7.2 Electrical Card Protection and the Backplane

Protection schemes for electrical cards depend on the EIA type used on the ONS 15454 backplane. The difference is due to the varying connector size. For example, because BNC connectors are larger, fewer DS3-12 cards can be supported when using a BNC connector. [Table 7-3](#) shows the number of connectors per side for each EIA type according to low-density and high-density interfaces.

In the tables, high-density (HD) cards include the DS3/EC1-48 and DS1/E1-56 cards. Low-density (LD) cards) include the following:

- DS1-14, DS1N-14
- DS3-12/DS3-12E, DS3N-12/DS3N-12E
- DS3XM-6
- DS3XM-12
- EC1-12



Note

For EIA installation, refer to the “Install the Shelf and Backplane Cable” chapter in the *Cisco ONS 15454 Procedure Guide*.



Caution

When a protection switch moves traffic from the working/active electrical card to the protect/standby electrical card, ports on the new active/standby card cannot be taken out of service as long as traffic is switched. Lost traffic can result when a port is taken out of service even if the standby electrical card no longer carries traffic.

Table 7-3 EIA Connectors Per Side

Interfaces per Side	Standard BNC	High-Density BNC	MiniBNC	SMB	AMP Champ	UBIC-V and UBIC-H (SCSI)
Total physical connectors	48	96	192	168	6	16
Maximum LD DS-1 Interfaces (transmit [Tx] and receive [Rx])	—	—	—	84	84	84
Maximum LD DS-3 interfaces (Tx and Rx)	24	48	72	72	—	72
Maximum HD DS-1 interfaces (Tx and Rx)	—	—	—	—	—	112
Maximum HD DS-3 interfaces (Tx and Rx)	—	—	96	—	—	96

Table 7-4 shows the electrical card protection for each EIA type according to shelf side and slots.

Table 7-4 Electrical Card Protection By EIA Type

Protection Type	Card Type	Side	Standard BNC	High-Density BNC	MiniBNC	SMB	AMP Champ	UBIC-V and UBIC-H (SCSI)
Unprotected	LD, Working	A	2, 4	1, 2, 4, 5	1–6	1–6	1–6	1–6
		B	14, 16	13, 14, 16, 17	12–17	12–17	12–17	12–17
	HD, Working	A	—	—	1, 2	—	—	1, 2
		B	—	—	16, 17	—	—	16, 17
1:1	LD, Working	A	2, 4	2, 4	2, 4, 6	2, 4, 6	2, 4, 6	2, 4, 6
		B	14, 16	14, 16	12, 14, 16	12, 14, 16	12, 14, 16	12, 14, 16
	LD, Protect	A	1, 3	1, 3	1, 3, 5	1, 3, 5	1, 3, 5	1, 3, 5
		B	15, 17	15, 17	13, 15, 17	13, 15, 17	13, 15, 17	13, 15, 17
1:N	LD, Working	A	—	1, 2, 4, 5	1–6	1–6	1–6	1–6
		B	—	13, 14, 16, 17	12–17	12–17	12–17	12–17
	LD, Protect	A	—	3	3	3	3	3
		B	—	15	15	15	15	15
	HD, Working	A	—	—	1, 2	—	—	1, 2
		B	—	—	16, 17	—	—	16, 17
	HD, Protect	A	—	—	3	—	—	3
		B	—	—	15	—	—	15

Figure 7-3 shows unprotected low-density electrical card schemes by EIA type.

Figure 7-3 Unprotected Low-Density Electrical Card Schemes for EIA Types

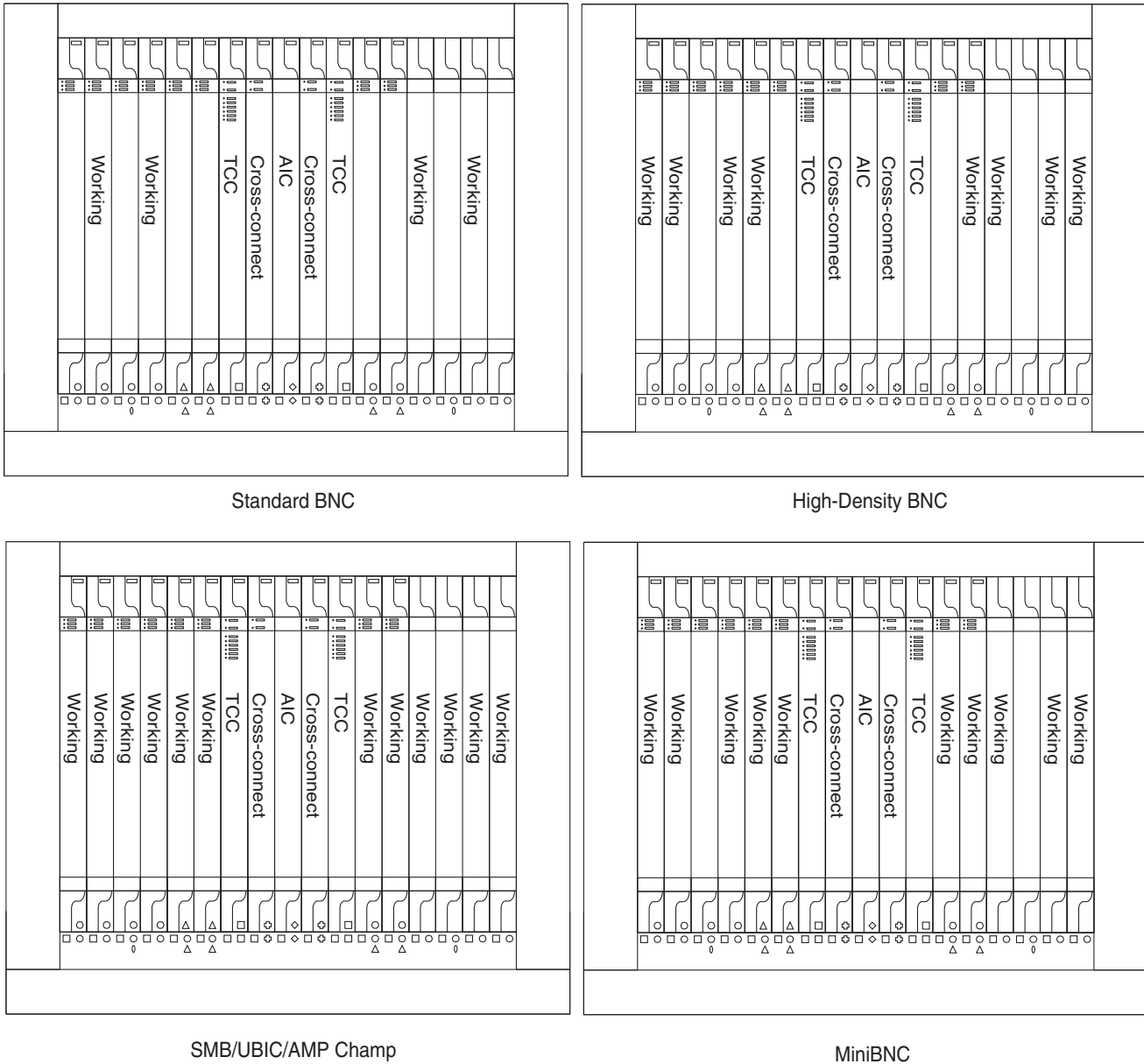

124060

Figure 7-4 shows unprotected high-density electrical card schemes by EIA type.

Figure 7-4 Unprotected High-Density Electrical Card Schemes for EIA Types

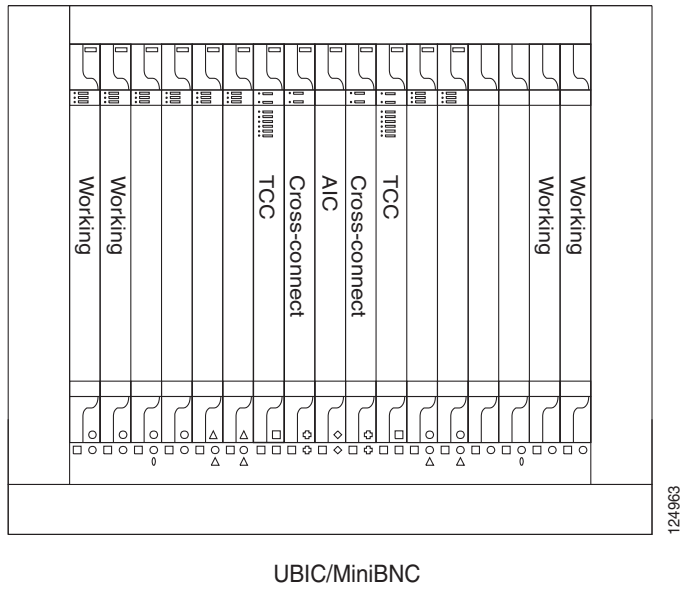
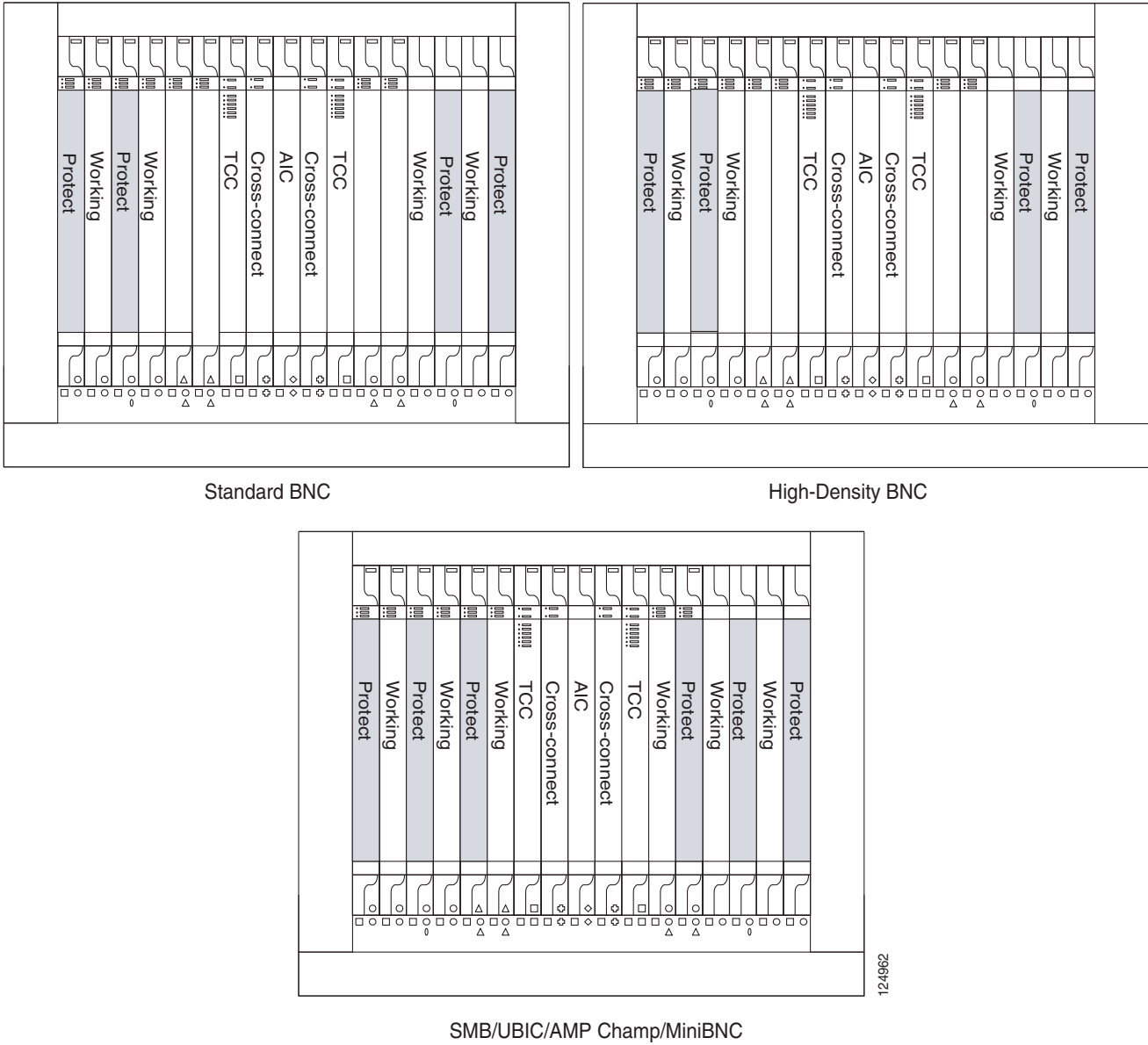

Figure 7-5 shows 1:1 low-density card protection by EIA type.

Figure 7-5 1:1 Protection Schemes for Low-Density Electrical Cards with EIA Types



296721

Figure 7-6 shows 1:N protection for low-density electrical cards.

Figure 7-6 1:N Protection Schemes for Low-Density Electrical Cards with EIA Types

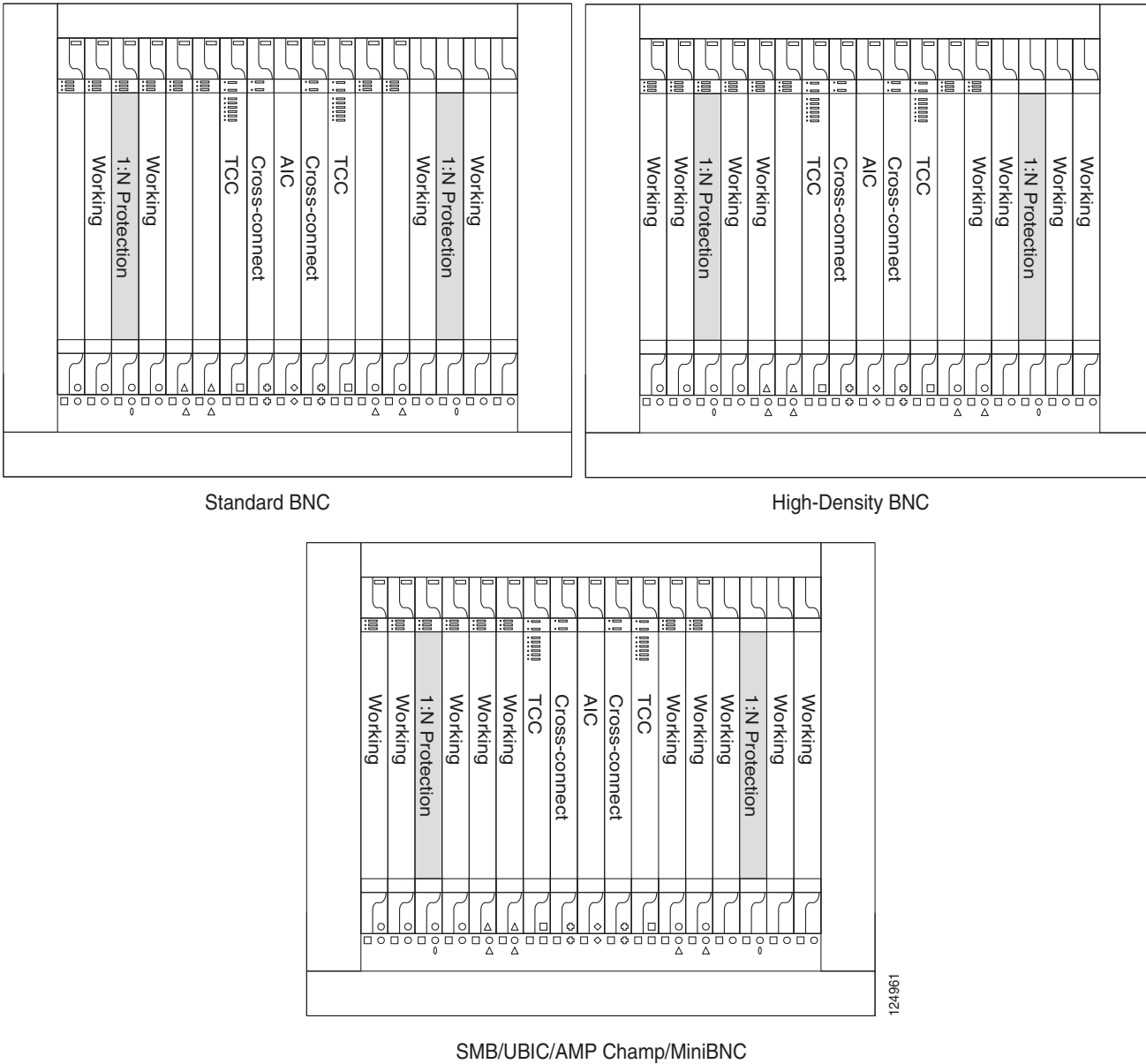

Note

EC-1 cards do not support 1:N protection.

Figure 7-7 shows 1:1 high-density card protection by EIA type.

Figure 7-7 1:1 Protection Schemes for High-Density Electrical Cards with UBIC or MiniBNC EIA Types

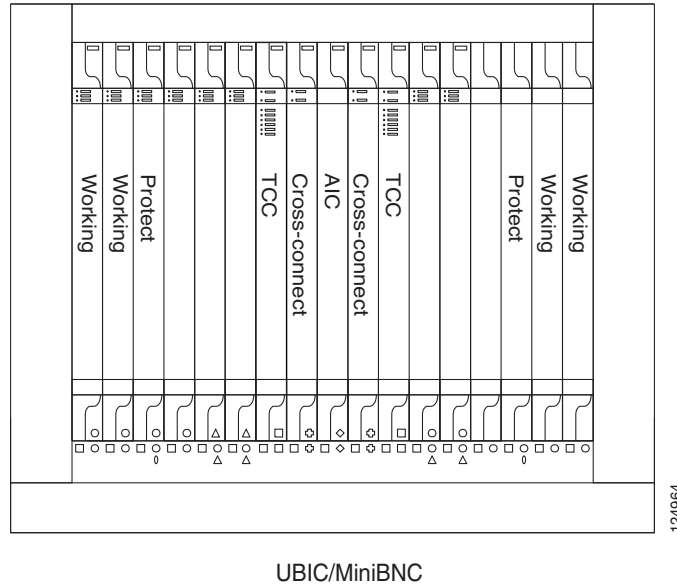

7.2.1 Standard BNC Protection

When used with the standard BNC EIA, the ONS 15454 supports unprotected, 1:1, or 1:N ($N \leq 2$) electrical card protection for DS-3 and EC-1 signals, as outlined in [Table 7-1 on page 7-2](#) and [Table 7-2 on page 7-3](#). The standard BNC EIA panel provides 48 BNC connectors for terminating up to 24 transmit and 24 receive signals per EIA panel, enabling 96 BNC connectors for terminating up to 48 transmit and receive signals per shelf with two standard-BNC panels installed. With an A-Side standard BNC EIA, Slots 2 and 4 can be used for working slots and with a B-Side EIA, Slots 14 and 16 can be used for working slots. Each of these slots is mapped to 24 BNC connectors on the EIA to support up to 12 transmit/receive signals. These slots can be used with or without equipment protection for DS-3 and EC-1 services.

7.2.2 High-Density BNC Protection

When used with the high-density BNC EIA, the ONS 15454 supports unprotected, 1:1, or 1:N ($N \leq 4$) electrical card protection for DS-3 and EC-1 signals, as outlined in [Table 7-1 on page 7-2](#) and [Table 7-2 on page 7-3](#). The high-density BNC EIA panel provides 96 BNC connectors for terminating up to 48 transmit and 24 receive signals per EIA panel, enabling 192 BNC connectors for terminating up to 96 transmit and receive signals per shelf with two high-density BNC panels installed. With an A-Side high-density BNC EIA, Slots 1, 2, 4, and 5 can be used for working slots and with a B-Side EIA, Slots 13, 14, 16, and 17 can be used for working slots. Each of these slots is mapped to 24 BNC connectors on the EIA to support up to 12 transmit/receive signals. These slots can be used with or without equipment protection for DS-3 and EC-1 services.

7.2.3 MiniBNC Protection

When used with the MiniBNC EIA, the ONS 15454 supports unprotected, 1:1, or 1:N ($N \leq 5$) electrical card protection for DS-1, DS-3 and EC-1 signals, as outlined in [Table 7-1 on page 7-2](#) and [Table 7-2 on page 7-3](#). The MiniBNC EIA provides 192 MiniBNC connectors for terminating up to 96 transmit and 96 receive signals per EIA, enabling 384 MiniBNC connectors for terminating up to 192 transmit and receive signals per shelf with two MiniBNC panels installed. With an A-Side MiniBNC EIA, Slots 1, 2, 4, 5, and 6 can be used for working slots and on a B-Side panel, Slots 12, 13, 14, 16, and 17 can be used for working slots. Each of these slots is mapped to 24 MiniBNC connectors on the EIA panel to support up to 12 transmit/receive signals. In addition, working Slots 1, 2, 16 and 17 can be mapped to 96 MiniBNC connectors to support the high-density electrical card. These slots can be used with or without equipment protection for DS-3 and EC-1 services.

7.2.4 SMB Protection

When used with the SMB EIA, the ONS 15454 supports unprotected, 1:1, or 1:N ($N \leq 5$) electrical card protection for DS-3 and EC-1 signals, as outlined in [Table 7-1 on page 7-2](#) and [Table 7-2 on page 7-3](#). The SMB EIA provides 168 SMB connectors for terminating up to 84 transmit and 84 receive signals per EIA, enabling 336 SMB connectors for terminating up to 168 transmit and receive signals per shelf with two SMB EIAs installed. With an A-Side SMB EIA, Slots 1, 2, 3, 4, 5, and 6 can be used for working slots and with a B-Side EIA, Slots 12, 13, 14, 15, 16, and 17 can be used for working slots. Each of these slots is mapped to 28 SMB connectors on the EIA to support up to 14 transmit/receive signals. These slots can be used with or without equipment protection for DS-1, DS-3 and EC-1 services. For DS-1 services, an SMB-to-wire-wrap balun is installed on the SMB ports for termination of the 100 ohm signal.

7.2.5 AMP Champ Protection

When used with the AMP Champ EIA, the ONS 15454 supports unprotected, 1:1, or 1:N ($N \leq 5$) electrical card protection for DS-1 signals, as outlined in [Table 7-1 on page 7-2](#) and [Table 7-2 on page 7-3](#). The AMP Champ EIA provides 6 AMP Champ connectors for terminating up to 84 transmit and 84 receive signals per EIA, enabling 12 AMP Champ connectors for terminating up to 168 transmit and receive signals per shelf with two AMP Champ EIAs installed. With an A-Side SMB EIA, Slots 1, 2, 3, 4, 5, and 6 can be used for working slots and with a B-Side EIA, Slots 12, 13, 14, 15, 16, and 17 can be used for working slots. Each of these slots is mapped to 1 AMP Champ connector on the EIA to support 14 transmit/receive signals. These slots can be used with or without equipment protection for DS-1 services.

7.2.6 UBIC Protection

When used with the UBIC EIA, the ONS 15454 high-density shelf assembly (15454-HD-SA) supports unprotected, 1:1, or 1:N ($N \leq 5$) electrical card protection for DS-1, DS-3 and EC-1 signals, as outlined in [Table 7-1 on page 7-2](#) and [Table 7-2 on page 7-3](#). The UBIC EIA provides 16 SCSI connectors for terminating up to 112 transmit and receive DS-1 signals per EIA, or up to 96 transmit and receive DS-3 connections. With an A-side UBIC EIA, Slots 1, 2, 3, 4, 5, and 6 can be used for working slots and with a B-Side EIA, Slots 12, 13, 14, 15, 16, and 17 can be used for working slots. Each of these slots is mapped to two SCSI connectors on the EIA to support up to 14 transmit/receive signals. In addition, working Slots 1, 2, 16, and 17 can be mapped to 8 SCSI connectors to support the high-density electrical card. These slots can be used with or without equipment protection for DS-1, DS-3, and EC-1 services.

7.3 OC-N Card Protection

The ONS 15454 provides two optical card protection methods, 1+1 protection and optimized 1+1 protection. This section covers the general concept of optical card protection. Specific optical card protection schemes depend on the optical cards in use.

7.3.1 1+1 Protection

Any OC-N card can use 1+1 protection. With 1+1 port-to-port protection, ports on the protect card can be assigned to protect the corresponding ports on the working card. The working and protect cards do not have to be placed side by side in the node. A working card must be paired with a protect card of the same type and number of ports. For example, a single-port OC-12 must be paired with another single-port OC-12, and a four-port OC-12 must be paired with another four-port OC-12. You cannot create a 1+1 protection group if one card is single-port and the other is multiport, even if the OC-N rates are the same. The protection takes place on the port level, and any number of ports on the protect card can be assigned to protect the corresponding ports on the working card.

For example, on a four-port card, you can assign one port as a protection port on the protect card (protecting the corresponding port on the working card) and leave three ports unprotected. Conversely, you can assign three ports as protection ports and leave one port unprotected. In other words, all the ports on the protect card are used in the protection scheme.

1+1 span protection can be either revertive or nonrevertive. With nonrevertive 1+1 protection, when a failure occurs and the signal switches from the working card to the protect card, the signal stays switched to the protect card until it is manually switched back. Revertive 1+1 protection automatically switches the signal back to the working card when the working card comes back online. 1+1 protection is unidirectional and nonrevertive by default; revertive switching is easily provisioned using CTC.

7.3.2 Optimized 1+1 Protection

Optimized 1+1 protection is used in networks that mainly use the linear 1+1 bidirectional protection scheme. Optimized 1+1 is a line-level protection scheme using two lines, working and protect. One of the two lines assumes the role of the primary channel, where traffic is selected, and the other line assumes the role of secondary channel, which protects the primary channel. Traffic switches from the primary channel to the secondary channel based on either line conditions or an external switching command performed by the user. After the line condition clears, the traffic remains on the secondary channel. The secondary channel is automatically renamed as the primary channel and the former primary channel is automatically renamed as the secondary channel.

Unlike 1+1 span protection, 1+1 optimized span protection does not use the revertive or nonrevertive feature. Also, 1+1 optimized span protection does not use the Manual switch command. The 1+1 optimized span protection scheme is supported only on the Cisco ONS 15454 SONET using either OC3-4 cards or OC3-8 cards with ports that are provisioned for SDH payloads.

Optimized 1+1 is fully compliant with Nippon Telegraph and Telephone Corporation (NTT) specifications. With optimized 1+1 port-to-port protection, ports on the protect card can be assigned to protect the corresponding ports on the working card. The working and protect cards do not have to be installed side by side in the node. A working card must be paired with a protect card of the same type and number of ports. For example, a four-port OC-3 must be paired with another four-port OC-3, and an eight-port OC-3 must be paired with another eight-port OC-3. You cannot create an optimized 1+1 protection group if the number of ports do not match, even if the OC-N rates are the same.

The protection takes place on the port level, and any number of ports on the protect card can be assigned to protect the corresponding ports on the working card. For example, on a four-port card, you can assign one port as a protection port on the protect card (protecting the corresponding port on the working card) and leave three ports unprotected. Conversely, you can assign three ports as protection ports and leave one port unprotected. With 1:1 or 1:N protection (electrical cards), the protect card must protect an entire slot. In other words, all the ports on the protect card are used in the protection scheme.

7.4 Unprotected Cards

Unprotected cards are not included in a protection scheme; therefore, a card failure or a signal error results in lost data. Because no bandwidth lies in reserve for protection, unprotected schemes maximize the available ONS 15454 bandwidth. [Figure 7-8](#) shows the ONS 15454 in an unprotected configuration. All cards are in a working state.

Figure 7-8 ONS 15454 in an Unprotected Configuration

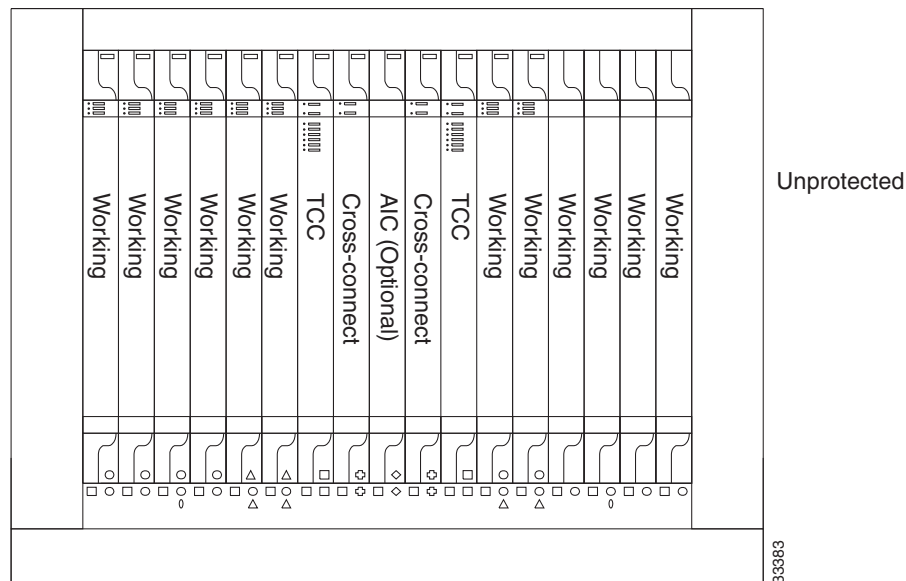

7.5 External Switching Commands

The external switching commands on the ONS 15454 are Manual, Force, and Lockout. If you choose a Manual switch, the command will switch traffic only if the path has an error rate less than the signal degrade (SD) bit error rate threshold. A Force switch will switch traffic even if the path has SD or signal fail (SF) conditions; however, a Force switch will not override an SF on a 1+1 protection channel.

A Force switch has a higher priority than a Manual switch. Lockouts, which prevent traffic from switching to the protect port under any circumstance, can only be applied to protect cards (in 1+1 configurations). Lockouts have the highest priority. In a 1+1 configuration you can also apply a lock on to the working port. A working port with a lock on applied cannot switch traffic to the protect port in the protection group (pair). In 1:1 protection groups, working or protect ports can have a lock on.

**Note**

Force and Manual switches do not apply to 1:1 protection groups; these ports have a single switch command.



CHAPTER 8

Cisco Transport Controller Operation

This chapter describes Cisco Transport Controller (CTC), the software interface for the Cisco ONS 15454. For CTC set up and login information, refer to the *Cisco ONS 15454 Procedure Guide*.

Chapter topics include:

- [8.1 CTC Software Delivery Methods, page 8-1](#)
- [8.2 CTC Installation Overview, page 8-3](#)
- [8.3 PC and UNIX Workstation Requirements, page 8-4](#)
- [8.4 ONS 15454 Connection, page 8-6](#)
- [8.5 CTC Window, page 8-7](#)
- [8.6 TCC2/TCC2P Card Reset, page 8-17](#)
- [8.7 TCC2/TCC2P Card Database, page 8-17](#)
- [8.8 Software Revert, page 8-18](#)

8.1 CTC Software Delivery Methods

ONS 15454 provisioning and administration is performed using the CTC software. CTC is a Java application that is installed in two locations; CTC is stored on the Advanced Timing, Communications, and Control (TCC2) card or the Advanced Timing, Communications, and Control Plus (TCC2P) card, and it is downloaded to your workstation the first time you log into the ONS 15454 with a new software release.

8.1.1 CTC Software Installed on the TCC2/TCC2P Card

CTC software is preloaded on the ONS 15454 TCC2/TCC2P cards; therefore, you do not need to install software on the TCC2/TCC2P cards. When a new CTC software version is released, use the release-specific software upgrade document to upgrade the ONS 15454 software on the TCC2/TCC2P cards.

When you upgrade CTC software, the TCC2/TCC2P cards store the new CTC version as the protect CTC version. When you activate the new CTC software, the TCC2/TCC2P cards store the older CTC version as the protect CTC version, and the newer CTC release becomes the working version. You can view the software versions that are installed on an ONS 15454 by selecting the Maintenance > Software tabs in node view ([Figure 8-1](#)).

Figure 8-1 CTC Software Versions, Node View

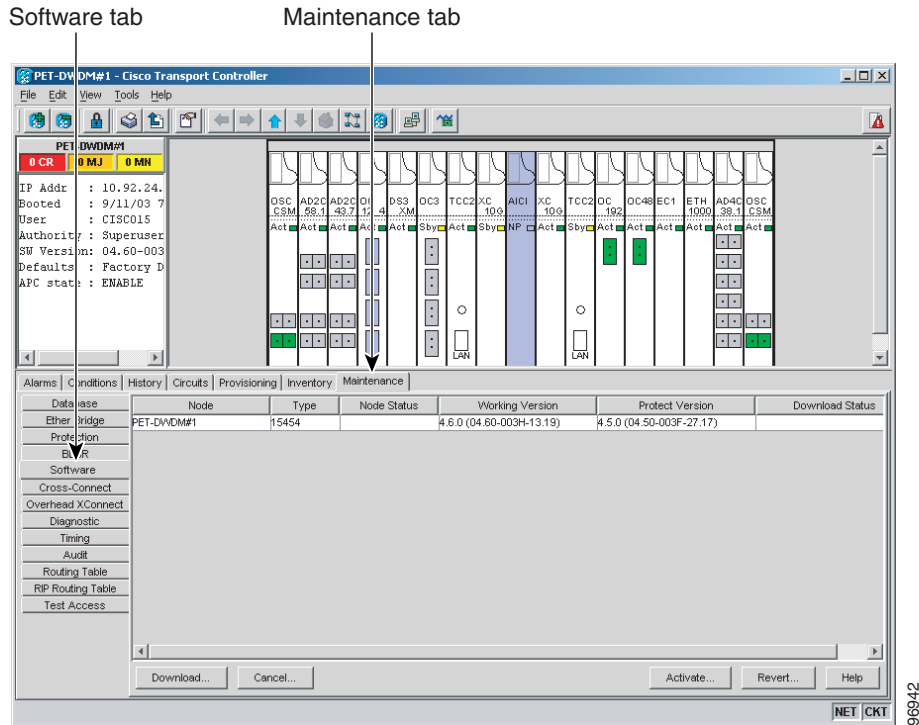

Select the Maintenance > Software tabs in network view to display the software versions installed on all the network nodes (Figure 8-2).

Figure 8-2 CTC Software Versions, Network View

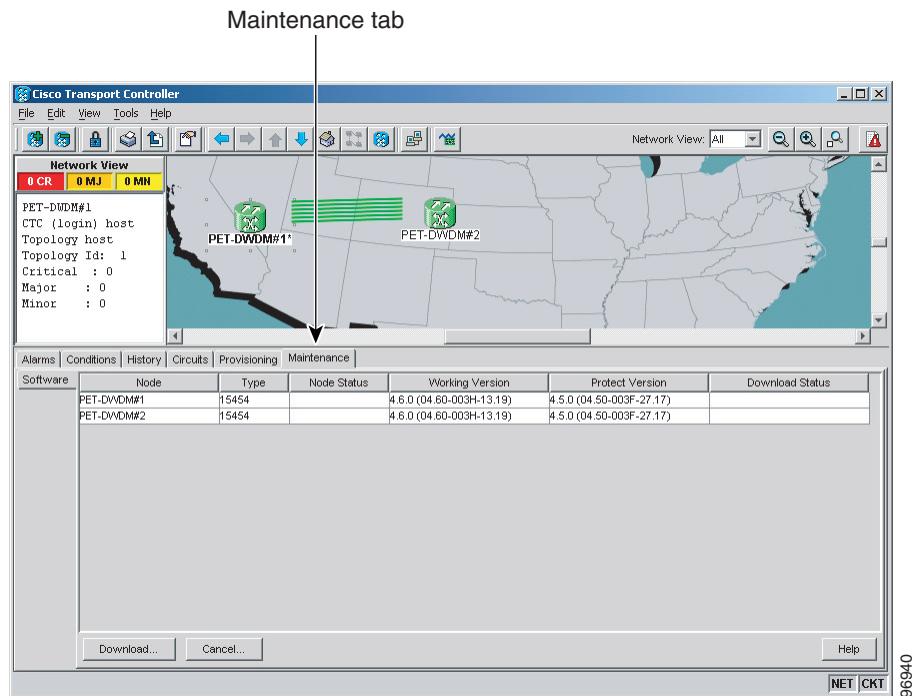

8.1.2 CTC Software Installed on the PC or UNIX Workstation

CTC software is downloaded from the TCC2/TCC2P cards and installed on your computer automatically after you connect to the ONS 15454 with a new software release for the first time. Downloading the CTC software files automatically ensures that your computer is running the same CTC software version as the TCC2/TCC2P cards you are accessing. The CTC files are stored in the temporary directory designated by your computer operating system. You can use the Delete CTC Cache button to remove files stored in the temporary directory. If the files are deleted, they download the next time you connect to an ONS 15454. Downloading the Java archive (JAR) files for CTC takes several minutes depending on the bandwidth of the connection between your workstation and the ONS 15454. For example, JAR files downloaded from a modem or a data communications channel (DCC) network link require more time than JAR files downloaded over a LAN connection.

During network topology discovery, CTC polls each node in the network to determine which one contains the most recent version of the CTC software. If CTC discovers a node in the network that has a more recent version of the CTC software than the version you are currently running, CTC generates a message stating that a later version of the CTC has been found in the network and offers to install the CTC software upgrade JAR files. If you have network discovery disabled, CTC will not seek more recent versions of the software. Unreachable nodes are not included in the upgrade discovery.

**Note**

Upgrading the CTC software will overwrite your existing software. You must restart CTC after the upgrade is complete.

8.2 CTC Installation Overview

To connect to an ONS 15454 using CTC, you enter the ONS 15454 IP address in the URL field of Netscape Navigator or Microsoft Internet Explorer. After connecting to an ONS 15454, the following occurs automatically:

1. A CTC launcher applet is downloaded from the TCC2/TCC2P card to your computer.
2. The launcher determines whether your computer has a CTC release matching the release on the ONS 15454 TCC2/TCC2P card.
3. If the computer does not have CTC installed, or if the installed release is older than the TCC2/TCC2P card's version, the launcher downloads the CTC program files from the TCC2/TCC2P card.
4. The launcher starts CTC. The CTC session is separate from the web browser session, so the web browser is no longer needed. Always log into nodes having the latest software release. If you log into an ONS 15454 that is connected to ONS 15454s with older versions of CTC, or to Cisco ONS 15327s or Cisco ONS 15600s, CTC files are downloaded automatically to enable you to interact with those nodes. The CTC file download occurs only when necessary, such as during your first login. You cannot interact with nodes on the network that have a software version later than the node that you used to launch CTC.

Each ONS 15454 can handle up to five concurrent CTC sessions. CTC performance can vary, depending on the volume of activity in each session, network bandwidth, and TCC2/TCC2P card load.

**Note**

You can also use TL1 commands to communicate with the Cisco ONS 15454 through VT100 terminals and VT100 emulation software, or you can telnet to an ONS 15454 using TL1 port 3083. Refer to the *Cisco ONS SONET TL1 Command Guide* for a comprehensive list of TL1 commands.

8.3 PC and UNIX Workstation Requirements

To use CTC for the ONS 15454, your computer must have a web browser with the correct Java Runtime Environment (JRE) installed. The correct JRE for each CTC software release is included on the Cisco ONS 15454 software CD. If you are running multiple CTC software releases on a network, the JRE installed on the computer must be compatible with the different software releases.

You can change the JRE version on the Preferences dialog box JRE tab. When you change the JRE version on the JRE tab, you must exit and restart CTC for the new JRE version to take effect. [Table 8-1](#) shows JRE compatibility with ONS 15454 software releases.

Table 8-1 JRE Compatibility

ONS Software Release	JRE 1.2.2 Compatible	JRE 1.3 Compatible	JRE 1.4 Compatible	JRE 5.0 Compatible
ONS 15454 Release 2.2.1 and earlier	Yes	No	No	No
ONS 15454 Release 2.2.2	Yes	Yes	No	No
ONS 15454 Release 3.0	Yes	Yes	No	No
ONS 15454 Release 3.1	Yes	Yes	No	No
ONS 15454 Release 3.2	Yes	Yes	No	No
ONS 15454 Release 3.3	Yes	Yes	No	No
ONS 15454 Release 3.4	No	Yes	No	No
ONS 15454 Release 4.0 ¹	No	Yes	No	No
ONS 15454 Release 4.1	No	Yes	No	No
ONS 15454 Release 4.5	No	Yes	No	No
ONS 15454 Release 4.6	No	Yes	Yes	No
ONS 15454 Release 5.0	No	No	Yes	No
ONS 15454 Release 6.0	No	No	Yes	No
ONS 15454 Release 7.0	No	No	Yes	Yes

1. Software Releases 4.0 and later notify you if an older version of the JRE is running on your PC or UNIX workstation.



Note

To avoid network performance issues, Cisco recommends managing a maximum of 50 nodes concurrently with CTC. The 50 nodes can be on a single DCC or split across multiple DCCs. Cisco does not recommend running multiple CTC sessions when managing two or more large networks.

To manage more than 50 nodes, Cisco recommends using Cisco Transport Manager (CTM). If you do use CTC to manage more than 50 nodes, you can improve performance by adjusting the heap size; see the “General Troubleshooting” chapter of the *Cisco ONS 15454 Troubleshooting Guide*. You can also create login node groups; see the “Connect the PC and Log Into the GUI” chapter of the *Cisco ONS 15454 Procedure Guide*.

[Table 8-2](#) lists the requirements for PCs and UNIX workstations. In addition to the JRE, the Java plug-in is included on the ONS 15454 software CD.

Table 8-2 Computer Requirements for CTC

Area	Requirements	Notes
Processor	Pentium III 700 MHz, UltraSPARC, or equivalent	700 MHz is the recommended processor speed. You can use computers with a lower processor speed; however, you might experience longer response times and slower performance.
RAM	384 MB RAM recommended, 512 MB RAM optimum	Cisco recommends using 512 MG RAM for networks with 25 nodes or more to avoid longer response times and slower performance.
Hard drive	20 GB hard drive with 50 MB of space available	—
Operating System	<ul style="list-style-type: none"> PC: Windows 98, Windows NT 4.0 with Service Pack 6a, Windows 2000 with Service Pack 3, or Windows XP with Service Pack 1 Workstation: Solaris versions 8 or 9 	—
Java Runtime Environment	JRE 1.4.2 or JRE 5.0	<p>JRE 1.4.2 is installed by the CTC Installation Wizard included on the Cisco ONS 15454 software CD. JRE 1.4.2 and JRE 5.0 provide enhancements to CTC performance, especially for large networks with numerous circuits.</p> <p>Cisco recommends that you use JRE 1.4.2 or JRE 5.0 for networks with Software R7.0 nodes. If CTC must be launched directly from nodes running software R5.0 or R6.0, Cisco recommends JRE 1.4.2. If CTC must be launched directly from nodes running software earlier than R5.0, Cisco recommends JRE 1.3.1_02.</p>

Table 8-2 Computer Requirements for CTC (continued)

Area	Requirements	Notes
Web browser	<ul style="list-style-type: none"> PC: Internet Explorer 6.x, Netscape 7.x UNIX Workstation: Mozilla 1.7 on Solaris 8 and 9, Netscape 4.76, Netscape 7.x 	<p>For the PC, use JRE 1.4.2 or JRE 5.0 with any supported web browser. Cisco recommends Internet Explorer 6.x. For UNIX, use JRE 5.0 with Netscape 7.x or JRE 1.3.1_02 with Netscape 4.76.</p> <p>Netscape 4.76 or 7.x is available at the following site: http://channels.netscape.com/ns/browsers/default.jsp</p> <p>Internet Explorer 6.x is available at the following site: http://www.microsoft.com</p>
Cable	User-supplied CAT-5 straight-through cable with RJ-45 connectors on each end to connect the computer to the ONS 15454 directly or through a LAN	—

8.4 ONS 15454 Connection

You can connect to the ONS 15454 in multiple ways. You can connect your PC directly to the ONS 15454 (local craft connection) using the RJ-45 port on the TCC2/TCC2P card or the LAN pins on the backplane, connect your PC to a hub or switch that is connected to the ONS 15454, connect to the ONS 15454 through a LAN or modem, or establish TL1 connections from a PC or TL1 terminal. [Table 8-3](#) lists the ONS 15454 connection methods and requirements.

Table 8-3 ONS 15454 Connection Methods

Method	Description	Requirements
Local craft	Refers to onsite network connections between the CTC computer and the ONS 15454 using one of the following: <ul style="list-style-type: none"> The RJ-45 (LAN) port on the TCC2/TCC2P card The LAN pins on the ONS 15454 backplane A hub or switch to which the ONS 15454 is connected 	If you do not use Dynamic Host Configuration Protocol (DHCP), you must change the computer IP address, subnet mask, and default router, or use automatic host detection.
Corporate LAN	Refers to a connection to the ONS 15454 through a corporate or network operations center (NOC) LAN.	<ul style="list-style-type: none"> The ONS 15454 must be provisioned for LAN connectivity, including IP address, subnet mask, and default gateway. The ONS 15454 must be physically connected to the corporate LAN. The CTC computer must be connected to the corporate LAN that has connectivity to the ONS 15454.
TL1	Refers to a connection to the ONS 15454 using TL1 rather than CTC. TL1 sessions can be started from CTC, or you can use a TL1 terminal. The physical connection can be a craft connection, corporate LAN, or a TL1 terminal.	Refer to the <i>Cisco ONS SONET TL1 Reference Guide</i> .
Remote	Refers to a connection made to the ONS 15454 using a modem.	<ul style="list-style-type: none"> A modem must be connected to the ONS 15454. The modem must be provisioned for the ONS 15454. To run CTC, the modem must be provisioned for Ethernet access.

8.5 CTC Window

The CTC window appears after you log into an ONS 15454 (Figure 8-3). The window includes a menu bar, a toolbar, and a top and bottom pane. The top pane provides status information about the selected objects and a graphic of the current view. The bottom pane provides tabs and subtab to view ONS 15454 information and perform ONS 15454 provisioning and maintenance. From this window you can display three ONS 15454 views: network, node, and card.

Figure 8-3 Node View (Default Login View)

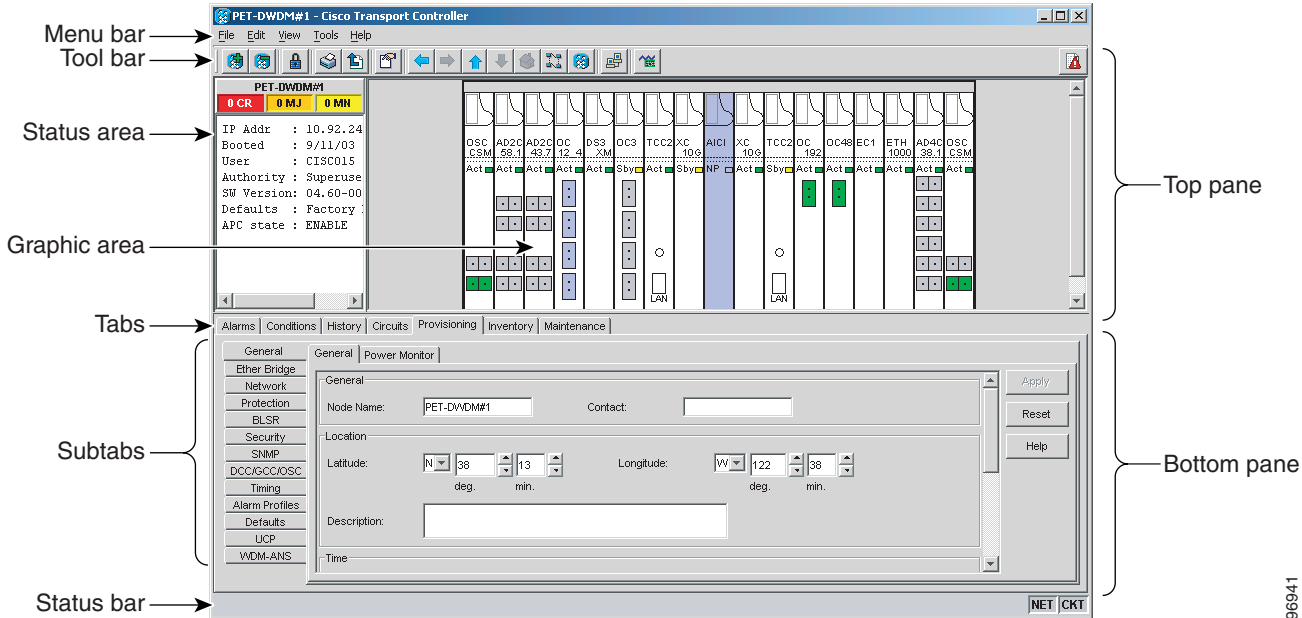

96941

8.5.1 Node View

Node view, shown in [Figure 8-3](#), is the first view that appears after you log into an ONS 15454. The login node is the first node shown, and it is the “home view” for the session. Node view allows you to manage one ONS 15454 node. The status area shows the node name; IP address; session boot date and time; number of Critical (CR), Major (MJ), and Minor (MN) alarms; the name of the current logged-in user; and the security level of the user; software version; and the network element default setup.

8.5.1.1 CTC Card Colors

The graphic area of the CTC window depicts the ONS 15454 shelf assembly. The colors of the cards in the graphic reflect the real-time status of the physical card and slot ([Table 8-4](#)).

Table 8-4 Node View Card Colors

Card Color	Status
Gray	Slot is not provisioned; no card is installed.
Violet	Slot is provisioned; no card is installed.
White	Slot is provisioned; a functioning card is installed.
Yellow	Slot is provisioned; a Minor alarm condition exists.
Orange	Slot is provisioned; a Major alarm condition exists.
Red	Slot is provisioned; a Critical alarm exists.

The wording on a card in node view shows the status of a card (Active, Standby, Loading, or Not Provisioned). [Table 8-5](#) lists the card statuses.

Table 8-5 Node View Card Statuses

Card Status	Description
Sby	Card is in standby mode.
Act	Card is active.
NP	Card is not present.
Ldg	Card is resetting.
Mis	Card is mismatched.

The port color in both card and node view indicates the port service state. [Table 8-6](#) lists the port colors and their service states. For more information about port service states, see [Appendix B, “Administrative and Service States.”](#)

Table 8-6 Node View Card Port Colors and Service States

Port Color	Service State	Description
Blue	OOS-MA,LPBK	(Out-of-Service and Management, Loopback) Port is in a loopback state. On the card in node view, a line between ports indicates that the port is in terminal or facility loopback (see Figure 8-4 on page 8-10 and Figure 8-5 on page 8-10). Traffic is carried and alarm reporting is suppressed. Raised fault conditions, whether or not their alarms are reported, can be retrieved on the CTC Conditions tab or by using the TL1 RTRV-COND command.
Blue	OOS-MA,MT	(Out-of-Service and Management, Maintenance) Port is out-of-service for maintenance. Traffic is carried and loopbacks are allowed. Alarm reporting is suppressed. Raised fault conditions, whether or not their alarms are reported, can be retrieved on the CTC Conditions tab or by using the TL1 RTRV-COND command. Use OOS-MA,MT for testing or to suppress alarms temporarily. Change the state to IS-NR, OOS-MA,DSBLD, or OOS-AU,AINS when testing is complete.
Gray	OOS-MA,DSBLD	(Out-of-Service and Management, Disabled) The port is out-of-service and unable to carry traffic. Loopbacks are not allowed in this service state.

Table 8-6 Node View Card Port Colors and Service States (continued)

Port Color	Service State	Description
Green	IS-NR	(In-Service and Normal) The port is fully operational and performing as provisioned. The port transmits a signal and displays alarms; loopbacks are not allowed.
Violet	OOS-AU,AINS	(Out-of-Service and Autonomous, Automatic In-Service) The port is out-of-service, but traffic is carried. Alarm reporting is suppressed. The node monitors the ports for an error-free signal. After an error-free signal is detected, the port stays in OOS-AU,AINS state for the duration of the soak period. After the soak period ends, the port service state changes to IS-NR. Raised fault conditions, whether or not their alarms are reported, can be retrieved on the CTC Conditions tab or by using the TL1 RTRV-COND command. The AINS port will automatically transition to IS-NR when a signal is received for the length of time provisioned in the soak field.

Figure 8-4 Terminal Loopback Indicator**Figure 8-5** Facility Loopback Indicator

8.5.1.2 Node View Card Shortcuts

If you move your mouse over cards in the graphic, popups display additional information about the card including the card type; the card status (active or standby); the type of alarm, such as Critical, Major, or Minor (if any); and the alarm profile used by the card. Right-click a card to reveal a shortcut menu, which you can use to open, reset, delete, or change a card. Right-click a slot to preprovision a card (that is, provision a slot before installing the card).

8.5.1.3 Node View Tabs

Table 8-7 lists the tabs and subtabs available in the node view.

Table 8-7 Node View Tabs and Subtabs

Tab	Description	Subtabs
Alarms	Lists current alarms (CR, MJ, MN) for the node and updates them in real time.	—
Conditions	Displays a list of standing conditions on the node.	—

Table 8-7 Node View Tabs and Subtabs (continued)

Tab	Description	Subtabs
History	Provides a history of node alarms including date, type, and severity of each alarm. The Session subtab displays alarms and events for the current session. The Node subtab displays alarms and events retrieved from a fixed-size log on the node.	Session, Node
Circuits	Creates, deletes, edits, and maps circuits and rolls.	Circuits, Rolls
Provisioning	Provisions the ONS 15454 node.	General, Ether Bridge, Network, OSI, BLSR, Protection, Security, SNMP, Comm Channels, Timing, Alarm Profiles, Cross-Connect, Defaults, WDM-ANS
Inventory	Provides inventory information (part number, serial number, Common Language Equipment Identification [CLEI] codes) for cards installed in the node. Allows you to delete and reset cards, and change card service state. For more information on card service states, see Appendix B, “Administrative and Service States.”	—
Maintenance	Performs maintenance tasks for the node.	Database, Ether Bridge, OSI, BLSR, Software, Cross-Connect, Overhead XConnect, Protection, Diagnostic, Timing, Audit, RIP Routing Table, Routing Table, Test Access, DWDM

8.5.2 Network View

Network view allows you to view and manage ONS 15454s that have DCC connections to the node that you logged into and any login node groups you have selected ([Figure 8-6](#)).

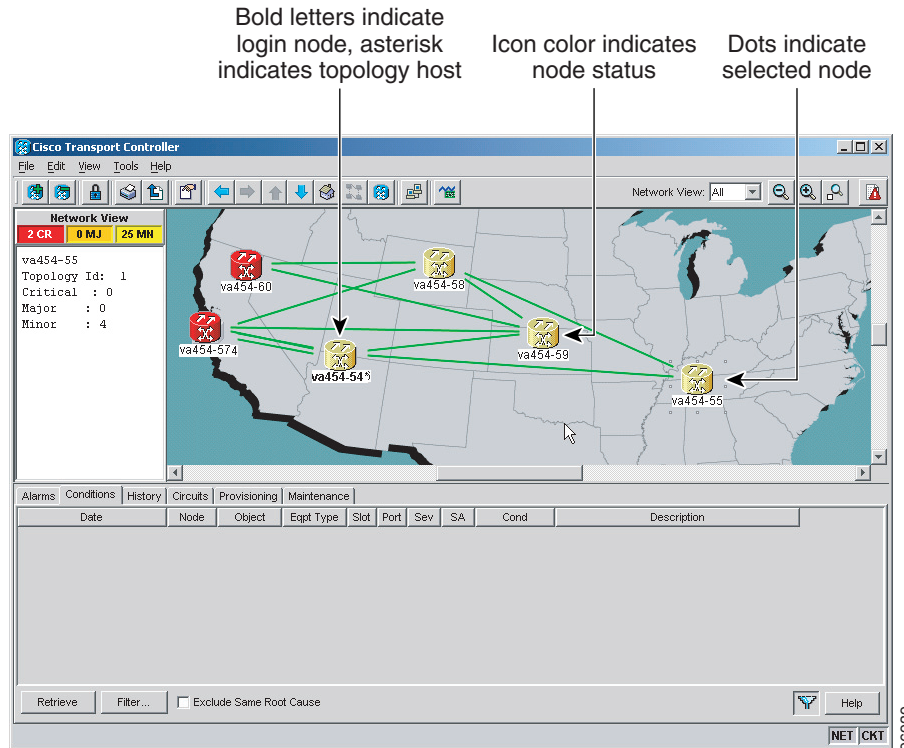
Figure 8-6 Network in CTC Network View**Note**

Nodes with DCC connections to the login node do not appear if you checked the Disable Network Discovery check box in the Login dialog box.

The graphic area displays a background image with colored ONS 15454 icons. A Superuser can set up the logical network view feature, which enables each user to see the same network view. Selecting a node or span in the graphic area displays information about the node and span in the status area.

8.5.2.1 Network View Tabs

Table 8-8 lists the tabs and subtabs available in network view.

Table 8-8 Network View Tabs and Subtabs

Tab	Description	Subtabs
Alarms	Lists current alarms (CR, MJ, MN) for the network and updates them in real time.	—
Conditions	Displays a list of standing conditions on the network.	—
History	Provides a history of network alarms including date, type, and severity of each alarm.	—
Circuits	Creates, deletes, edits, filters, and searches for network circuits and rolls.	Circuits, Rolls

Table 8-8 Network View Tabs and Subtabs (continued)

Tab	Description	Subtabs
Provisioning	Provisions security, alarm profiles, bidirectional line switched rings (BLSRs), and overhead circuits.	Security, Alarm Profiles, BLSR, Overhead Circuits, Provisionable Patchcords (PPC)
Maintenance	Displays the type of equipment and the status of each node in the network; displays working and protect software versions; and allows software to be downloaded.	Software

8.5.2.2 CTC Node Colors

The color of a node in network view, shown in [Table 8-9](#), indicates the node alarm status.

Table 8-9 Node Status Shown in Network View

Color	Alarm Status
Green	No alarms
Yellow	Minor alarms
Orange	Major alarms
Red	Critical alarms
Gray with Unknown#	Node initializing for the first time (CTC displays Unknown# because CTC has not discovered the name of the node yet)

8.5.2.3 DCC Links

The lines show DCC connections between the nodes ([Table 8-10](#)). DCC connections can be green (active) or gray (fail). The lines can also be solid (circuits can be routed through this link) or dashed (circuits cannot be routed through this link). Circuit provisioning uses active/routable links.

Table 8-10 DCC Colors Indicating State in Network View





Color and Line Style	State
Green and solid	Active/Routable
Green and dashed	Active/Nonroutable
Gray and solid	Failed/Routable
Gray and dashed	Failed/Nonroutable

8.5.2.4 Link Consolidation

CTC provides the ability to consolidate the DCC, general communications channel (GCC), optical transport section (OTS), provisionable patchcord (PPC), and server trail links shown in the network view. Link consolidation allows you to condense multiple inter-nodal links into a single link. The link consolidation sorts links by class; for example, all DCC links are consolidated together. You can access individual links within consolidated links using the right-click shortcut menu.

Each link has an associated icon ([Table 8-11](#)).

Table 8-11 Link Icons

Icon	Description
	DCC icon
	GCC icon
	OTS icon
	PPC icon
	Server Trail icon

**Note**

Link consolidation is only available on non-detailed maps. Non-detailed maps display nodes in icon form instead of detailed form, meaning the nodes appear as rectangles with ports on the sides. Refer to the *Cisco ONS 15454 Procedure Guide* for more information about consolidated links.

8.5.3 Card View

The card view provides information about individual ONS 15454 cards. Use this window to perform card-specific maintenance and provisioning ([Figure 8-7](#)). A graphic showing the ports on the card is shown in the graphic area. The status area displays the node name, slot, number of alarms, card type, equipment type, and the card status (active or standby), card service state if the card is present, and port service state (described in [Table 8-6 on page 8-9](#)). The information that appears and the actions you can perform depend on the card. For more information about card service states, see [Appendix B, “Administrative and Service States.”](#)

Figure 8-7 CTC Card View Showing a DS1 Card

Card identification and status

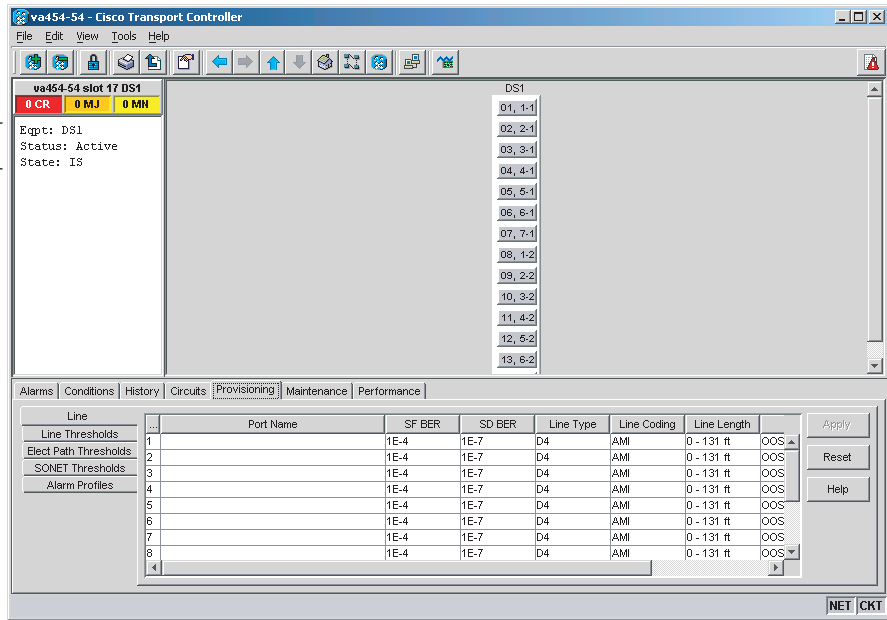

 **Note**

CTC provides a card view for all ONS 15454 cards except the TCC2, TCC2P, XCVT, XC10G, and XC-VXC-10G cards. Provisioning for these common control cards occurs at the node view; therefore, no card view is necessary.

Use the card view tabs and subtabs shown in Table 8-12 to provision and manage the ONS 15454. The subtabs, fields, and information shown under each tab depend on the card type selected. The Performance tab is not available for the Alarm Interface Controller-International (AIC-I) cards.

Table 8-12 Card View Tabs and Subtabs

Tab	Description	Subtabs
Alarms	Lists current alarms (CR, MJ, MN) for the card and updates them in real time.	—
Conditions	Displays a list of standing conditions on the card.	—
History	Provides a history of card alarms including date, object, port, and severity of each alarm.	Session (displays alarms and events for the current session), Card (displays alarms and events retrieved from a fixed-size log on the card)
Circuits	Creates, deletes, edits, and search circuits and rolls.	Circuits, Rolls

Table 8-12 Card View Tabs and Subtabs (continued)

Tab	Description	Subtabs
Provisioning	Provisions an ONS 15454 card.	DS-N and OC-N cards: Line, Line Thresholds (different threshold options are available for DS-N and OC-N cards), Elect Path Thresholds, SONET Thresholds, or SONET STS, and Alarm Profiles TXP and MXP cards: Card, Line, Line Thresholds (different threshold options are available for electrical and optical cards), Optics Thresholds, OTN, Pluggable Port Modules, and Alarm Profiles DWDM cards (subtabs depend on card type): Optical Line, Optical Chn, Optical Band, Optical Amplifier, Parameters, Optics Thresholds
Maintenance	Performs maintenance tasks for the card.	Loopback, Info, Protection, J1 Path Trace, AINS Soak (options depend on the card type), Automatic Laser Shutdown (TXP and MXP cards only)
Performance	Performs performance monitoring for the card.	DS-N and OC-N cards: no subtabs TXP and MXP cards: Optics PM, Payload PM, OTN PM DWDM cards (subtabs depend on card type): Optical Line, Optical Chn, Optical Amplifier, Parameters, Optics Thresholds
Inventory	Displays an Inventory screen of the ports (TXP and MXP cards only).	—

**Note**

For TXP, MXP, and DWDM card information, refer to the *Cisco ONS 15454 DWDM Reference Manual*.

8.5.4 Print or Export CTC Data

You can use the File > Print or File > Export options to print or export CTC provisioning information for record keeping or troubleshooting. The functions can be performed in card, node, or network views. The File > Print function sends the data to a local or network printer. File > Export exports the data to a file where it can be imported into other computer applications, such as spreadsheets and database management programs.

Whether you choose to print or export data, you can choose from the following options:

- Entire frame—Prints or exports the entire CTC window including the graphical view of the card, node, or network. This option is available for all windows.
- Tabbed view—Prints or exports the lower half of the CTC window containing tabs and data. The printout includes the selected tab (on top) and the data shown in the tab window. For example, if you print the History window Tabbed view, you print only history items appearing in the window. This option is available for all windows.
- Table Contents—Prints or exports CTC data in table format without graphical representations of shelves, cards, or tabs. The Table Contents option prints all the data contained in a table with the same column headings. For example, if you print the History window Table Contents view, you print all data included in the table whether or not items appear in the window.

The Table Contents option does not apply to all windows; for a list of windows that do not support print or export, see the *Cisco ONS 15454 Procedure Guide*.

8.6 TCC2/TCC2P Card Reset

You can reset the ONS 15454 TCC2/TCC2P card by using CTC (a soft reset) or by physically reseating a TCC2/TCC2P card (a hard reset). A soft reset reboots the TCC2/TCC2P card and reloads the operating system and the application software. Additionally, a hard reset temporarily removes power from the TCC2/TCC2P card and clears all buffer memory.

You can apply a soft reset from CTC to either an active or standby TCC2/TCC2P card without affecting traffic. If you need to perform a hard reset on an active TCC2/TCC2P card, put the TCC2/TCC2P card into standby mode first by performing a soft reset.

**Note**

When a CTC reset is performed on an active TCC2/TCC2P card, the AIC-I cards go through an initialization process and also reset because AIC-I cards are controlled by the active TCC2/TCC2P.

8.7 TCC2/TCC2P Card Database

When dual TCC2/TCC2P cards are installed in the ONS 15454, each TCC2/TCC2P card hosts a separate database; therefore, the protect card database is available if the database on the working TCC2/TCC2P fails. You can also store a backup version of the database on the workstation running CTC. This operation should be part of a regular ONS 15454 maintenance program at approximately weekly intervals, and should also be completed when preparing an ONS 15454 for a pending natural disaster, such as a flood or fire.

**Note**

The following parameters are not backed up and restored: node name, IP address, mask and gateway, and Internet Inter-ORB Protocol (IIOP) port. If you change the node name and then restore a backed up database with a different node name, the circuits map to the new node name. Cisco recommends keeping a record of the old and new node names.

**Note**

To avoid a node IP and secure IP ending up in the same domain after restoring a database, ensure that the node IP stored in the database differs in domain from that of the node in repeater mode. Also, after restoring a database, ensure that the node IP and secure IP differ in domain.

8.8 Software Revert

When you click the Activate button after a software upgrade, the TCC2/TCC2P copies the current working database and saves it in a reserved location in the TCC2/TCC2P flash memory. If you later need to revert to the original working software load from the protect software load, the saved database installs automatically. You do not need to restore the database manually or recreate circuits.

**Note**

The TCC2/TCC2P card does not carry any software earlier than Software R4.0. You will not be able to revert to a software release earlier than Software R4.0 with TCC2/TCC2P cards installed.

The revert feature is useful if a maintenance window closes while you are upgrading CTC software. You can revert to the protect software load without losing traffic. When the next maintenance window opens, complete the upgrade and activate the new software load.

Circuits created and provisioning done after a software load is activated (upgraded to a higher software release) will be lost with a revert. The database configuration at the time of activation is reinstated after a revert. This does not apply to maintenance reverts (for example, 4.6.2 to 4.6.1), because maintenance releases use the same database.

To perform a supported (non-service-affecting) revert from Software R7.0, the release you want to revert to must have been working at the time you first activated Software R7.0 on that node. Because a supported revert automatically restores the node configuration at the time of the previous activation, any configuration changes made after activation will be lost when you revert the software. Downloading Release 7.0 a second time after you have activated the new load ensures that no actual revert to a previous load can take place (the TCC2/TCC2P card will reset, but will not be traffic affecting and will not change your database).



CHAPTER 9

Security

This chapter provides information about Cisco ONS 15454 users and security. To provision security, refer to the *Cisco ONS 15454 Procedure Guide*.

Chapter topics include:

- [9.1 User IDs and Security Levels, page 9-1](#)
- [9.2 User Privileges and Policies, page 9-1](#)
- [9.3 Audit Trail, page 9-7](#)
- [9.4 RADIUS Security, page 9-8](#)

9.1 User IDs and Security Levels

The CISCO15 user ID is provided with the ONS 15454 for initial login to the node, but this user ID is not supplied in the prompt when you sign into Cisco Transport Controller (CTC). This ID can be used to set up other ONS 15454 user IDs.

You can have up to 500 user IDs on one ONS 15454. Each CTC or Transaction Language One (TL1) user can be assigned one of the following security levels:

- Retrieve—Users can retrieve and view CTC information but cannot set or modify parameters.
- Maintenance—Users can access only the ONS 15454 maintenance options.
- Provisioning—Users can access provisioning and maintenance options.
- Superuser—Users can perform all of the functions of the other security levels as well as set names, passwords, and security levels for other users.

See [Table 9-3 on page 9-6](#) for idle user timeout information for each security level.

By default, multiple concurrent user ID sessions are permitted on the node; that is, multiple users can log into a node using the same user ID. However, you can provision the node to allow only a single login per user ID and prevent concurrent logins for all users.

9.2 User Privileges and Policies

This section lists user privileges for each CTC action and describes the security policies available to Superusers for provisioning.

9.2.1 User Privileges by CTC Action

Table 9-1 shows the actions that each user privilege level can perform in node view.

Table 9-1 ONS 15454 Security Levels—Node View

CTC Tab	Subtab	[Subtab]:Actions	Retrieve	Maintenance	Provisioning	Superuser
Alarms	—	Synchronize/Filter/Delete Cleared Alarms	X ¹	X	X	X
Conditions	—	Retrieve/Filter	X	X	X	X
History	Session	Filter	X	X	X	X
	Shelf	Retrieve/Filter	X	X	X	X
Circuits	Circuits	Create/Edit/Delete	— ²	—	X	X
		Filter/Search	X	X	X	X
	Rolls	Complete/ Force Valid Signal/ Finish	—	—	X	X
Provisioning	General	General: Edit	—	—	Partial ³	X
		Multishelf Config: Edit	X	X	X	X
		Power Monitor: Edit	—	—	X	X
	EtherBridge	Spanning trees: Edit	—	—	X	X
	Network	General: Edit	—	—	—	X
		General: View	X	X	X	X
		Static Routing: Create/Edit/Delete	—	—	X	X
		OSPF: Create/Edit/Delete	—	—	X	X
		RIP: Create/Edit/Delete	—	—	X	X
		Proxy: Create/Edit/Delete	—	—	—	X
		Firewall: Create/Edit/Delete	—	—	—	X
		OSI	Main Setup: Edit	—	—	—
	TARP: Config: Edit	—	—	—	X	
	TARP: Static TDC: Add/Edit/Delete	—	—	X	X	
	TARP: MAT: Add/Edit/Remove	—	—	X	X	
	Routers: Setup: Edit	—	—	—	X	
	Routers: Subnets: Edit/Enable/Disable	—	—	X	X	
	Tunnels: Create/Edit/Delete	—	—	X	X	
	BLSR	Create/Edit/Delete/Upgrade	—	—	X	X
		Ring Map/Squelch Table/RIP Table	X	X	X	X
	Protection	Create/Edit/Delete	—	—	X	X

Table 9-1 ONS 15454 Security Levels—Node View (continued)

CTC Tab	Subtab	[Subtab]:Actions	Retrieve	Maintenance	Provisioning	Superuser
Security		Users: Create/Delete/Clear Security Intrusion Alarm	—	—	—	X
		Users: Edit	Same user	Same user	Same user	All users
		Active Logins: View/Logout/Retrieve Last Activity Time	—	—	—	X
		Policy: Edit/View	—	—	—	X
		Access: Edit/View	—	—	—	X
		RADIUS Server: Create/Edit/Delete/Move Up/Move Down/View	—	—	—	X
		Legal Disclaimer: Edit	—	—	—	X
SNMP		Create/Edit/Delete	—	—	X	X
		Browse trap destinations	X	X	X	X
Comm Channels		SDCC: Create/Edit/Delete	—	—	X	X
		LDCC: Create/Edit/Delete	—	—	X	X
		GCC: Create/Edit/Delete	—	—	X	X
		OSC: OSC Terminations: Create/Edit/Delete	—	—	X	X
		OSC: DWDM Ring ID: Create/Edit/Delete	—	—	—	X
		PPC: Create/Edit/Delete	—	—	X	X
Timing		General: Edit	—	—	X	X
		BITS Facilities: Edit	—	—	X	X
Alarm Profiles		Alarm Behavior: Edit	—	—	X	X
		Alarm Profile Editor: Store/Delete ⁴	—	—	X	X
		Alarm Profile Editor: New/Load/Compare/Available/Usage	X	X	X	X
Cross-Connect		Edit	—	—	X	X
Defaults		Edit/Import	—	—	—	X
		Reset/Export	X	X	X	X
WDM-ANS		Provisioning: Edit	—	—	—	X
		Provisioning: Reset	X	X	X	X
		Internal Patchcords: Create/Edit/Delete/Commit/Default Patchcords	—	—	X	X
		Port Status: Launch ANS	—	—	—	X
		Node Setup	X	X	X	X

Table 9-1 ONS 15454 Security Levels—Node View (continued)

CTC Tab	Subtab	[Subtab]:Actions	Retrieve	Maintenance	Provisioning	Superuser
Inventory	—	Delete	—	—	X	X
		Reset	—	X	X	X
Maintenance	Database	Backup	—	X	X	X
		Restore	—	—	—	X
	EtherBridge	Spanning Trees	X	X	X	X
		MAC Table: Retrieve	X	X	X	X
		MAC Table: Clear/Clear All	—	X	X	X
		Trunk Utilization: Refresh	X	X	X	X
		Circuits: Refresh	X	X	X	X
	Network	Routing Table: Retrieve	X	X	X	X
		RIP Routing Table: Retrieve	X	X	X	X
	OSI	IS-IS RIB: Refresh	X	X	X	X
		ES-IS RIB: Refresh	X	X	X	X
		TDC: TID to NSAP/Flush Dynamic Entries	—	X	X	X
		TDC: Refresh	X	X	X	X
	BLSR	Edit/Reset	—	X	X	X
	Protection	Switch/Lock out/Lockon/Clear/ Unlock	—	X	X	X
	Software	Download	—	X	X	X
		Activate/Revert	—	—	—	X
	Cross-Connect	Cards: Switch/Lock/Unlock	—	X	X	X
		Resource Usage: Delete	—	—	X	X
	Overhead XConnect	View	X	X	X	X
	Diagnostic	Retrieve Tech Support Log	—	—	X	X
		Lamp Test	—	X	X	X
	Timing	Source: Edit	—	X	X	X
		Report: View/Refresh	X	X	X	X
	Audit	Retrieve	—	—	—	X
		Archive	—	—	X	X
	Test Access	View	X	X	X	X
DWDM	APC: Run/Disable/Refresh	—	X	X	X	
	WDM Span Check: Edit/Retrieve Span Loss values/Reset	X	X	X	X	
	ROADM Power Monitoring: Refresh	X	X	X	X	

1. The X indicates that the user can perform the actions.
2. The — indicates that the privilege to perform an action is not available to the user.
3. Provisioner user cannot change node name, contact, or AIS-V insertion on STS-1 signal degrade (SD) parameters.
4. The action buttons in the subtab are active for all users, but the actions can be completely performed only by the users with the required security levels.

Table 9-2 shows the actions that each user privilege level can perform in network view.

Table 9-2 ONS 15454 Security Levels—Network View

CTC Tab	Subtab	[Subtab]: Actions	Retrieve	Maintenance	Provisioning	Superuser
Alarms	—	Synchronize/Filter/Delete cleared alarms	X ¹	X	X	X
Conditions	—	Retrieve/Filter	X	X	X	X
History	—	Filter	X	X	X	X
Circuits	Circuits	Create/Edit/Delete	— ²	—	X	X
		Filter/Search	X	X	X	X
	Rolls	Complete, Force Valid Signal, Finish	—	—	X	X
Provisioning	Security	Users: Create/Delete	—	—	—	X
		Users: Edit	Same user	Same user	Same user	All users
		Active logins: Logout/Retrieve Last Activity Time	—	—	—	X
		Policy: Change	—	—	—	X
	Alarm Profiles	Store/Delete ³	—	—	X	X
		New/Load/Compare/Available/Usage	X	X	X	X
	BLSR	Create/Delete/Edit/Upgrade	—	—	X	X
	Overhead Circuits	Create/Delete/Edit/Merge	—	—	X	X
		Search	X	X	X	X
	Provisionable Patchcords (PPC)	Create/Edit/Delete	—	—	X	X
Server Trails	Create/Edit/Delete	—	—	X	X	
Maintenance	Software	Download/Cancel	—	X	—	X
	Diagnostic	OSPF Node Information: Retrieve/Clear	X	X	X	X

1. The X indicates that the user can perform the actions.
2. The — indicates that the privilege to perform an action is not available to the user.
3. The action buttons in the subtab are active for all users, but the actions can be completely performed only by the users with the required security levels.

9.2.2 Security Policies

Users with Superuser security privileges can provision security policies on the ONS 15454. These security policies include idle user timeouts, password changes, password aging, and user lockout parameters. In addition, a Superuser can access the ONS 15454 through the TCC2/TCC2P RJ-45 port, the backplane LAN connection, or both.

9.2.2.1 Superuser Privileges for Provisioning Users

Superusers can grant permission to Provisioning users to retrieve audit logs, restore databases, clear performance monitoring (PM) parameters, activate software loads, and revert software loads. These privileges can only be set using CTC network element (NE) defaults, except the PM clearing privilege, which can be granted to a Provisioning user using the CTC Provisioning > Security > Access tabs. For more information about setting up Superuser privileges, refer to the *Cisco ONS 15454 Procedure Guide*.

9.2.2.2 Idle User Timeout

Each ONS 15454 CTC or TL1 user can be idle during his or her login session for a specified amount of time before the CTC window is locked. The lockouts prevent unauthorized users from making changes. Higher-level users have shorter default idle periods and lower-level users have longer or unlimited default idle periods, as shown in [Table 9-3](#). The user idle period can be modified by a Superuser; refer to the *Cisco ONS 15454 Procedure Guide* for instructions.

Table 9-3 ONS 15454 Default User Idle Times

Security Level	Idle Time
Superuser	15 minutes
Provisioning	30 minutes
Maintenance	60 minutes
Retrieve	Unlimited

9.2.2.3 User Password, Login, and Access Policies

Superusers can view real-time lists of users who are logged into CTC or TL1 by node. Superusers can also provision the following password, login, and node access policies:

- Password expirations and reuse—Superusers can specify when users must change and when they can reuse their passwords.
- Locking out and disabling users—Superusers can provision the number of invalid logins that are allowed before locking out users and the length of time before inactive users are disabled.
- Node access and user sessions—Superusers can limit the number of CTC sessions a user login can have to just one session. Superusers can also prohibit access to the ONS 15454 using the LAN or TCC2/TCC2P RJ-45 connections.

In addition, a Superuser can select secure shell (SSH) instead of Telnet at the CTC Provisioning > Security > Access tabs. SSH is a terminal-remote host Internet protocol that uses encrypted links. It provides authentication and secure communication over unsecure channels. Port 22 is the default port and cannot be changed. Superuser can also configure EMS and TL1 access states to secure and non-secure modes.

**Note**

The superuser cannot modify the privilege level of an active user. The CTC displays a warning message when the superuser attempts to modify the privilege level of an active user.

9.2.2.4 Secure Access

Secure access is based on SSH and SSL protocols. Secure access can be enabled for EMS (applicable to CTC). When access is set to secure, CTC provides enhanced SFTP and SSH security when communicating with the node.

For more information on how to enable EMS secure access, refer *Cisco ONS 15454 Procedure Guide* for instructions.

9.3 Audit Trail

The Cisco ONS 15454 maintains a Telcordia GR-839-CORE-compliant audit trail log that resides on the TCC2/TCC2P card. Audit trails are useful for maintaining security, recovering lost transactions, and enforcing accountability. Accountability refers to tracing user activities; that is, associating a process or action with a specific user. The audit trail log shows who has accessed the system and what operations were performed during a given period of time. The log includes authorized Cisco support logins and logouts using the operating system command line interface (CLI), CTC, and TL1; the log also includes FTP actions, circuit creation/deletion, and user/system generated actions.

Event monitoring is also recorded in the audit log. An event is defined as the change in status of a network element. External events, internal events, attribute changes, and software upload/download activities are recorded in the audit trail.

To view the audit trail log, refer to the *Cisco ONS 15454 Procedure Guide*. You can access the audit trail logs from any management interface (CTC, CTM, TL1).

The audit trail is stored in persistent memory and is not corrupted by processor switches, resets, or upgrades. However, if you remove both TCC2/TCC2P cards, the audit trail log is lost.

9.3.1 Audit Trail Log Entries

Table 9-4 contains the columns listed in Audit Trail window.

Table 9-4 **Audit Trail Window Columns**

Heading	Explanation
Date	Date when the action occurred
Num	Incrementing count of actions
User	User ID that initiated the action
P/F	Pass/Fail (whether or not the action was executed)
Operation	Action that was taken

Audit trail records capture the following activities:

- User—Name of the user performing the action

- Host—Host from where the activity is logged
- Device ID—IP address of the device involved in the activity
- Application—Name of the application involved in the activity
- Task—Name of the task involved in the activity (view a dialog box, apply configuration, etc.)
- Connection Mode—Telnet, Console, SNMP
- Category—Type of change (Hardware, Software, Configuration)
- Status—Status of the user action (Read, Initial, Successful, Timeout, Failed)
- Time—Time of change
- Message Type—Whether the event is Success/Failure type
- Message Details—Description of the change

9.3.2 Audit Trail Capacities

The ONS 15454 is able to store 640 log entries. When this limit is reached, the oldest entries are overwritten with new events. When the log server is 80 percent full, an AUD-LOG-LOW condition is raised and logged (by way of CORBA/CTC).

When the log server reaches the maximum capacity of 640 entries and begins overwriting records that were not archived, an AUD-LOG-LOSS condition is raised and logged. This event indicates that audit trail records have been lost. Until you off-load the file, this event will not occur a second time regardless of the amount of entries that are overwritten by incoming data. To export the audit trail log, refer to the *Cisco ONS 15454 Procedure Guide*.

9.4 RADIUS Security

Users with Superuser security privileges can configure nodes to use Remote Authentication Dial In User Service (RADIUS) authentication. Cisco Systems uses a strategy known as authentication, authorization, and accounting (AAA) for verifying the identity of, granting access to, and tracking the actions of remote users.

9.4.1 RADIUS Authentication

RADIUS is a system of distributed security that secures remote access to networks and network services against unauthorized access. RADIUS comprises three components:

- A protocol with a frame format that utilizes User Datagram Protocol (UDP)/IP
- A server
- A client

The server runs on a central computer, typically at a customer site, while the clients reside in the dial-up access servers and can be distributed throughout the network.

An ONS 15454 node operates as a client of RADIUS. The client is responsible for passing user information to designated RADIUS servers, and then acting on the response that is returned. RADIUS servers are responsible for receiving user connection requests, authenticating the user, and returning all configuration information necessary for the client to deliver service to the user. The RADIUS servers can act as proxy clients to other kinds of authentication servers. Transactions between the RADIUS

client and server are authenticated through the use of a shared secret, which is never sent over the network. In addition, any user passwords are sent encrypted between the client and RADIUS server. This eliminates the possibility that someone monitoring an unsecured network could determine a user's password. Refer to the *Cisco ONS 15454 Procedure Guide* for detailed instructions for implementing RADIUS authentication.

9.4.2 Shared Secrets

A shared secret is a text string that serves as a password between:

- A RADIUS client and RADIUS server
- A RADIUS client and a RADIUS proxy
- A RADIUS proxy and a RADIUS server

For a configuration that uses a RADIUS client, a RADIUS proxy, and a RADIUS server, the shared secret that is used between the RADIUS client and the RADIUS proxy can be different from the shared secret used between the RADIUS proxy and the RADIUS server.

Shared secrets are used to verify that RADIUS messages, with the exception of the Access-Request message, are sent by a RADIUS-enabled device that is configured with the same shared secret. Shared secrets also verify that the RADIUS message has not been modified in transit (message integrity). The shared secret is also used to encrypt some RADIUS attributes, such as User-Password and Tunnel-Password.

When creating and using a shared secret:

- Use the same case-sensitive shared secret on both RADIUS devices.
- Use a different shared secret for each RADIUS server-RADIUS client pair.
- To ensure a random shared secret, generate a random sequence at least 22 characters long.
- You can use any standard alphanumeric and special characters.
- You can use a shared secret of up to 128 characters in length. To protect your server and your RADIUS clients from brute force attacks, use long shared secrets (more than 22 characters).
- Make the shared secret a random sequence of letters, numbers, and punctuation and change it often to protect your server and your RADIUS clients from dictionary attacks. Shared secrets should contain characters from each of the three groups listed in [Table 9-5](#).

Table 9-5 Shared Secret Character Groups

Group	Examples
Letters (uppercase and lowercase)	A, B, C, D and a, b, c, d
Numerals	0, 1, 2, 3
Symbols (all characters not defined as letters or numerals)	Exclamation point (!), asterisk (*), colon (:)

The stronger your shared secret, the more secure are the attributes (for example, those used for passwords and encryption keys) that are encrypted with it. An example of a strong shared secret is 8d#>9fq4bV)H7%a3-zE13sW\$hIa32M#m<PqAa72(.



CHAPTER 10

Timing

This chapter provides information about Cisco ONS 15454 SONET timing. To provision timing, refer to the *Cisco ONS 15454 Procedure Guide*.

Chapter topics include:

- [10.1 Timing Parameters, page 10-1](#)
- [10.2 Network Timing, page 10-2](#)
- [10.3 Synchronization Status Messaging, page 10-3](#)

10.1 Timing Parameters

SONET timing parameters must be set for each ONS 15454. Each ONS 15454 independently accepts its timing reference from one of three sources:

- The building integrated timing supply (BITS) pins on the ONS 15454 backplane.
- An OC-N card installed in the ONS 15454. The card is connected to a node that receives timing through a BITS source.
- The internal ST3 clock on the TCC2/TCC2P card.

You can set ONS 15454 timing to one of three modes: external, line, or mixed. If timing is coming from the BITS pins, set ONS 15454 timing to external. If the timing comes from an OC-N card, set the timing to line. In typical ONS 15454 networks:

- One node is set to external. The external node derives its timing from a BITS source wired to the BITS backplane pins. The BITS source, in turn, derives its timing from a primary reference source (PRS) such as a Stratum 1 clock or global positioning satellite (GPS) signal.
- The other nodes are set to line. The line nodes derive timing from the externally timed node through the OC-N trunk (span) cards.

You can set three timing references for each ONS 15454. The first two references are typically two BITS-level sources, or two line-level sources optically connected to a node with a BITS source. The third reference is usually assigned to the internal clock provided on every ONS 15454 TCC2/TCC2P card. However, if you assign all three references to other timing sources, the internal clock is always available as a backup timing reference. The internal clock is a Stratum 3 (ST3), so if an ONS 15454 node becomes isolated, timing is maintained at the ST3 level.

The CTC Maintenance > Timing > Report tabs show current timing information for an ONS 15454, including the timing mode, clock state and status, switch type, and reference data.

**Caution**

Mixed timing allows you to select both external and line timing sources. However, Cisco does not recommend its use because it can create timing loops. Use this mode with caution.

10.2 Network Timing

Figure 10-1 shows an ONS 15454 network timing setup example. Node 1 is set to external timing. Two timing references are set to BITS. These are Stratum 1 timing sources wired to the BITS input pins on the Node 1 backplane. The third reference is set to internal clock. The BITS output pins on the backplane of Node 3 are used to provide timing to outside equipment, such as a digital access line multiplexer.

In the example, Slots 5 and 6 contain the trunk (span) cards. Timing at Nodes 2, 3, and 4 is set to line, and the timing references are set to the trunk cards based on distance from the BITS source. Reference 1 is set to the trunk card closest to the BITS source. At Node 2, Reference 1 is Slot 5 because it is connected to Node 1. At Node 4, Reference 1 is set to Slot 6 because it is connected to Node 1. At Node 3, Reference 1 could be either trunk card because they are an equal distance from Node 1.

Figure 10-1 ONS 15454 Timing Example

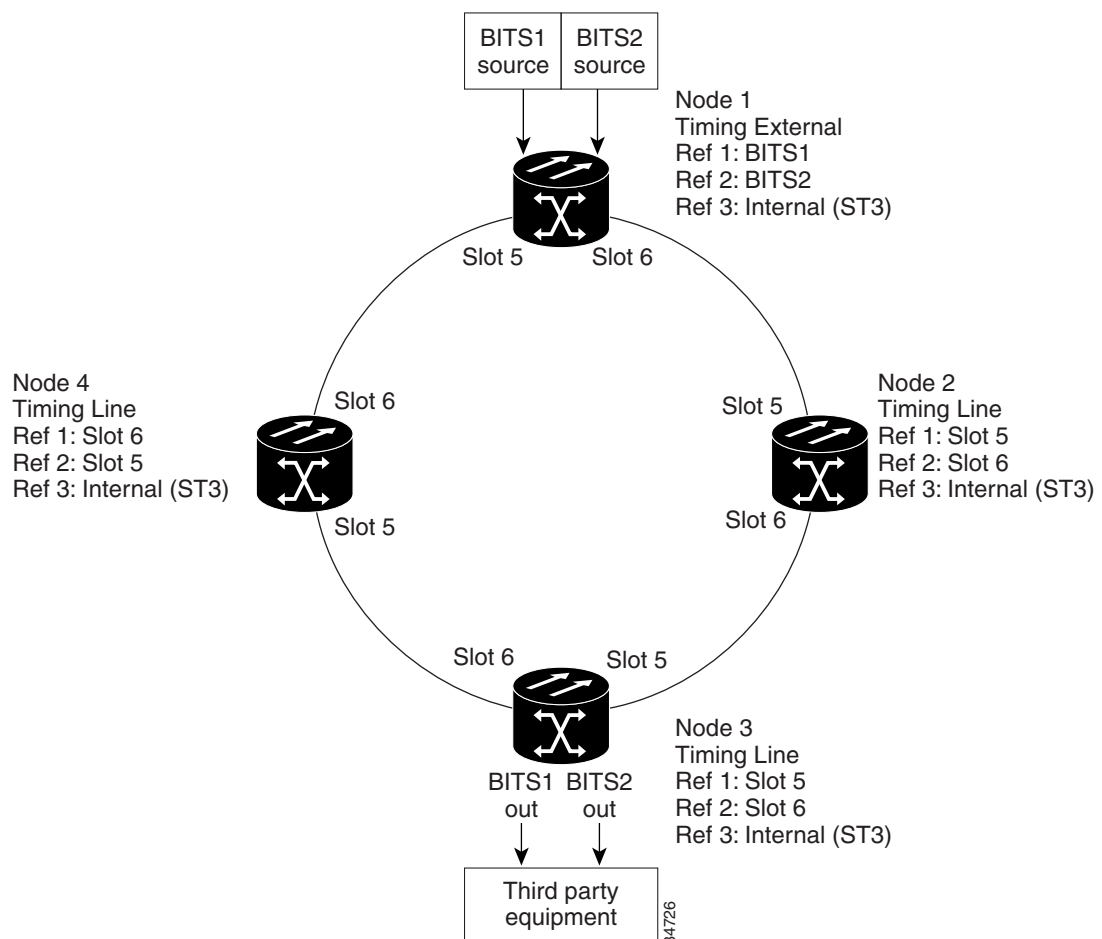

10.3 Synchronization Status Messaging

Synchronization status messaging (SSM) is a SONET protocol that communicates information about the quality of the timing source. SSM messages are carried on the S1 byte of the SONET Line layer. They enable SONET devices to automatically select the highest quality timing reference and to avoid timing loops.

SSM messages are either Generation 1 or Generation 2. Generation 1 is the first and most widely deployed SSM message set. Generation 2 is a newer version. If you enable SSM for the ONS 15454, consult your timing reference documentation to determine which message set to use. [Table 10-1](#) and [Table 10-2 on page 10-3](#) show the Generation 1 and Generation 2 message sets.

Table 10-1 SSM Generation 1 Message Set

Message	Quality	Description
PRS	1	Primary reference source—Stratum 1
STU	2	Synchronization traceability unknown
ST2	3	Stratum 2
ST3	4	Stratum 3
SMC	5	SONET minimum clock
ST4	6	Stratum 4
DUS	7	Do not use for timing synchronization
RES	—	Reserved; quality level set by user

Table 10-2 SSM Generation 2 Message Set

Message	Quality	Description
PRS	1	Primary reference source—Stratum 1
STU	2	Synchronization traceability unknown
ST2	3	Stratum 2
TNC	4	Transit node clock
ST3E	5	Stratum 3E
ST3	6	Stratum 3
SMC	7	SONET minimum clock
ST4	8	Stratum 4
DUS	9	Do not use for timing synchronization
RES	—	Reserved; quality level set by user



CHAPTER 11

Circuits and Tunnels



Note

The terms "Unidirectional Path Switched Ring" and "UPSR" may appear in Cisco literature. These terms do not refer to using Cisco ONS 15xxx products in a unidirectional path switched ring configuration. Rather, these terms, as well as "Path Protected Mesh Network" and "PPMN," refer generally to Cisco's path protection feature, which may be used in any topological network configuration. Cisco does not recommend using its path protection feature in any particular topological network configuration.

This chapter explains Cisco ONS 15454 synchronous transport signal (STS), virtual tributary (VT), and virtual concatenated (VCAT) circuits and VT, data communications channel (DCC), and IP-encapsulated tunnels. To provision circuits and tunnels, refer to the *Cisco ONS 15454 Procedure Guide*.

Chapter topics include:

- [11.1 Overview, page 11-2](#)
- [11.2 Circuit Properties, page 11-2](#)
- [11.3 Cross-Connect Card Bandwidth, page 11-12](#)
- [11.4 Portless Transmux, page 11-15](#)
- [11.5 DCC Tunnels, page 11-16](#)
- [11.6 SDH Tunneling, page 11-18](#)
- [11.7 Multiple Destinations for Unidirectional Circuits, page 11-18](#)
- [11.8 Monitor Circuits, page 11-19](#)
- [11.9 Path Protection Circuits, page 11-19](#)
- [11.10 BLSR Protection Channel Access Circuits, page 11-21](#)
- [11.11 BLSR STS and VT Squelch Tables, page 11-22](#)
- [11.12 Section and Path Trace, page 11-23](#)
- [11.13 Path Signal Label, C2 Byte, page 11-24](#)
- [11.14 Automatic Circuit Routing, page 11-26](#)
- [11.15 Manual Circuit Routing, page 11-28](#)
- [11.16 Constraint-Based Circuit Routing, page 11-32](#)
- [11.17 Virtual Concatenated Circuits, page 11-33](#)
- [11.18 Bridge and Roll, page 11-36](#)
- [11.19 Merged Circuits, page 11-42](#)

- [11.20 Reconfigured Circuits, page 11-43](#)
- [11.21 VLAN Management, page 11-43](#)
- [11.22 Server Trails, page 11-43](#)

11.1 Overview

You can create circuits across and within ONS 15454 nodes and assign different attributes to circuits. For example, you can:

- Create one-way, two-way (bidirectional), or broadcast circuits.
- Assign user-defined names to circuits.
- Assign different circuit sizes.
- Automatically or manually route circuits.
- Automatically create multiple circuits with autoranging. VT tunnels do not use autoranging.
- Provide full protection to the circuit path.
- Provide only protected sources and destinations for circuits.
- Define a secondary circuit source or destination that allows you to interoperate an ONS 15454 path protection with third-party equipment path protection configurations.
- Set path protection circuits as revertive or nonrevertive.

You can provision circuits at either of the following points:

- Before cards are installed. The ONS 15454 allows you to provision slots and circuits before installing the traffic cards.
- After you preprovision the Small Form-factor Pluggables (SFPs) (also called provisionable port modules [PPMs]).
- After cards and SFPs are installed and ports are in service. Circuits do not actually carry traffic until the cards and SFPs are installed and the ports are In-Service and Normal (IS-NR); Out-of-Service and Autonomous, Automatic In-Service (OO-AU,AINS); or Out-of-Service and Management, Maintenance (OOS-MA,MT). Circuits carry traffic as soon as the signal is received.

11.2 Circuit Properties

The ONS 15454 Cisco Transport Controller (CTC) Circuits window, which appears in network, node, and card view, is where you can view information about circuits. The Circuits window ([Figure 11-1](#)) provides the following information:

- Name—The name of the circuit. The circuit name can be manually assigned or automatically generated.
- Type—The circuit types are STS (STS circuit), VT (VT circuit), VTT (VT tunnel), VAP (VT aggregation point), OCHNC (dense wavelength division multiplexing [DWDM] optical channel network connection; refer to the *Cisco ONS 15454 DWDM Installation and Operations Guide*), STS-V (STS VCAT circuit), or VT-V (VT VCAT circuit).
- Size—The circuit size. VT circuits are 1.5. STS circuit sizes are 1, 3c, 6c, 9c, 12c, 24c, 36c, 48c, and 192c. OCHNC sizes are Equipped non specific, Multi-rate, 2.5 Gbps No FEC (forward error correction), 2.5 Gbps FEC, 10 Gbps No FEC, and 10 Gbps FEC (OCHNC is DWDM only; refer to

the *Cisco ONS 15454 DWDM Installation and Operations Guide*). VCAT circuits are VT1.5-*nv*, STS-1-*nv*, STS-3c-*nv*, and STS-12c-*nv*, where *n* is the number of members. For time slot availability on concatenated STSs, see the “[11.2.1 Concatenated STS Time Slot Assignments](#)” section on [page 11-4](#).

- OCHNC Wlen—For OCHNCs, the wavelength provisioned for the optical channel network connection. For more information, refer to the *Cisco ONS 15454 DWDM Installation and Operations Guide*.
- Direction—The circuit direction, either two-way or one-way.
- OCHNC Dir—For OCHNCs, the direction of the optical channel network connection, either east to west or west to east. For more information, refer to the *Cisco ONS 15454 DWDM Installation and Operations Guide*.
- Protection—The type of circuit protection. See the “[11.2.4 Circuit Protection Types](#)” section on [page 11-9](#) for a list of protection types.
- Status—The circuit status. See the “[11.2.2 Circuit Status](#)” section on [page 11-6](#).
- Source—The circuit source in the format: *node/slot/port “port name”/STS/VT*. (The port name appears in quotes.) Node and slot always appear; *port “port name”/STS/VT* might appear, depending on the source card, circuit type, and whether a name is assigned to the port. For the OC192-XFP and MRC-12 cards, the port appears as *port pluggable module (PPM)-port*. If the circuit size is a concatenated size (3c, 6c, 12c, etc.), STSs used in the circuit are indicated by an ellipsis, for example, S7..9, (STSs 7, 8, and 9) or S10..12 (STS 10, 11, and 12).
- Destination—The circuit destination in the same format as the circuit source.
- # of VLANS—The number of VLANs used by an Ethernet circuit.
- # of Spans—The number of internode links that constitute the circuit. Right-clicking the column shows a shortcut menu from which you can choose Span Details to show or hide circuit span detail. For each node in the span, the span detail shows the *node/slot (card type)/port/STS/VT*.
- State—The circuit state. See the “[11.2.3 Circuit States](#)” section on [page 11-7](#).

The Filter button allows you to filter the circuits in network, node, or card view based on circuit name, size, type, direction, and other attributes. In addition, you can export the Circuit window data in HTML, comma-separated values (CSV), or tab-separated values (TSV) format using the Export command from the File menu.

Figure 11-1 ONS 15454 Circuit Window in Network View

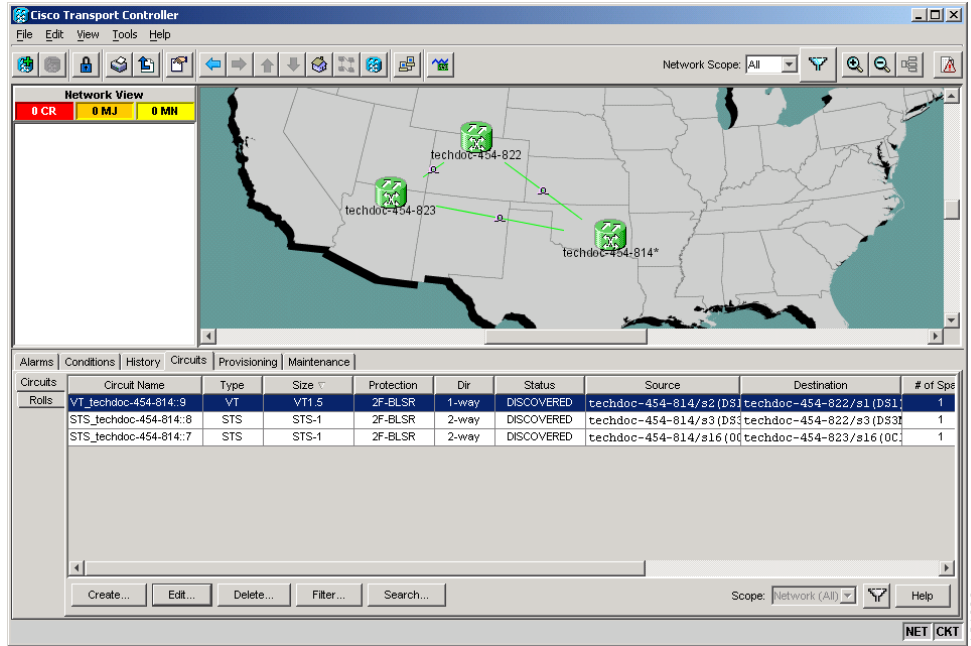

11.2.1 Concatenated STS Time Slot Assignments

Table 11-1 shows the available time slot assignments for concatenated STSs when using CTC to provision circuits.

Table 11-1 STS Mapping Using CTC

Starting STS	STS-3c	STS-6c	STS-9c	STS-12c	STS-18c	STS-24c	STS-36c	STS-48c	STS-192c
1	Yes	Yes	Yes	Yes	Yes	Yes	Yes	Yes	Yes
4	Yes	Yes	Yes	No	Yes	Yes	Yes	No	No
7	Yes	Yes	No	No	Yes	Yes	Yes	No	No
10	Yes	No	Yes	No	Yes	Yes	Yes	No	No
13	Yes	Yes	Yes	Yes	Yes	Yes	Yes	No	No
16	Yes	Yes	Yes	No	Yes	Yes	No	No	No
19	Yes	Yes	Yes	No	Yes	Yes	No	No	No
22	Yes	No	No	No	Yes	Yes	No	No	No
25	Yes	Yes	Yes	Yes	Yes	Yes	No	No	No
28	Yes	Yes	Yes	No	Yes	No	No	No	No
31	Yes	Yes	No	No	Yes	No	No	No	No
34	Yes	No	No	No	No	No	No	No	No
37	Yes	Yes	Yes	Yes	Yes	No	Yes	No	No

Table 11-1 STS Mapping Using CTC (continued)

Starting STS	STS-3c	STS-6c	STS-9c	STS-12c	STS-18c	STS-24c	STS-36c	STS-48c	STS-192c
40	Yes	Yes	Yes	No	No	No	No	No	No
43	Yes	Yes	No	No	No	No	No	No	No
46	Yes	No	Yes	No	No	No	No	No	No
49	Yes	Yes	Yes	Yes	Yes	Yes	Yes	Yes	No
52	Yes	Yes	Yes	No	Yes	Yes	Yes	No	No
55	Yes	Yes	Yes	No	Yes	Yes	Yes	No	No
58	Yes	No	No	No	Yes	Yes	Yes	No	No
61	Yes	Yes	Yes	Yes	Yes	Yes	Yes	No	No
64	Yes	Yes	Yes	No	Yes	Yes	No	No	No
67	Yes	Yes	No	No	Yes	Yes	No	No	No
70	Yes	No	No	No	Yes	Yes	No	No	No
73	Yes	Yes	Yes	Yes	Yes	Yes	Yes	No	No
76	Yes	Yes	Yes	No	Yes	No	No	No	No
79	Yes	Yes	No	No	Yes	No	No	No	No
82	Yes	No	Yes	No	No	No	No	No	No
85	Yes	Yes	Yes	Yes	No	No	No	No	No
88	Yes	Yes	Yes	No	No	No	No	No	No
91	Yes	Yes	Yes	No	Yes	No	No	No	No
94	Yes	No	No	No	No	No	No	No	No
97	Yes	Yes	Yes	Yes	Yes	Yes	Yes	Yes	No
100	Yes	Yes	Yes	No	Yes	Yes	Yes	No	No
103	Yes	Yes	No	No	Yes	Yes	Yes	No	No
106	Yes	No	No	No	Yes	Yes	Yes	No	No
109	Yes	Yes	Yes	Yes	Yes	Yes	Yes	No	No
112	Yes	Yes	Yes	No	Yes	Yes	No	No	No
115	Yes	Yes	No	No	Yes	Yes	No	No	No
118	Yes	No	Yes	No	Yes	Yes	No	No	No
121	Yes	Yes	Yes	Yes	Yes	Yes	No	No	No
124	Yes	Yes	Yes	No	Yes	No	No	No	No
127	Yes	Yes	Yes	No	Yes	No	No	No	No
130	Yes	No	No	No	No	No	No	No	No
133	Yes	Yes	Yes	Yes	No	No	No	No	No
136	Yes	Yes	Yes	No	No	No	No	No	No
139	Yes	Yes	No	No	No	No	No	No	No
142	Yes	No	No	No	No	No	No	No	No

Table 11-1 STS Mapping Using CTC (continued)

Starting STS	STS-3c	STS-6c	STS-9c	STS-12c	STS-18c	STS-24c	STS-36c	STS-48c	STS-192c
145	Yes	Yes	Yes	Yes	Yes	Yes	Yes	Yes	No
148	Yes	Yes	Yes	No	Yes	Yes	Yes	No	No
151	Yes	Yes	No	No	Yes	Yes	Yes	No	No
154	Yes	No	Yes	No	Yes	Yes	Yes	No	No
157	Yes	Yes	Yes	Yes	Yes	Yes	Yes	No	No
160	Yes	Yes	Yes	No	Yes	Yes	No	No	No
163	Yes	Yes	Yes	No	Yes	Yes	No	No	No
166	Yes	No	No	No	Yes	Yes	No	No	No
169	Yes	Yes	Yes	Yes	Yes	Yes	No	No	No
172	Yes	Yes	Yes	No	Yes	No	No	No	No
175	Yes	Yes	No	No	Yes	No	No	No	No
178	Yes	No	No	No	No	No	No	No	No
181	Yes	Yes	Yes	Yes	Yes	No	No	No	No
184	Yes	Yes	Yes	No	Yes	No	No	No	No
187	Yes	Yes	No	No	Yes	No	No	No	No
190	Yes	No	No	No	Yes	No	No	No	No

11.2.2 Circuit Status

The circuit statuses that appear in the Circuit window Status column are generated by CTC based on conditions along the circuit path. Table 11-2 shows the statuses that can appear in the Status column.

Table 11-2 ONS 15454 Circuit Status

Status	Definition/Activity
CREATING	CTC is creating a circuit.
DISCOVERED	CTC created a circuit. All components are in place and a complete path exists from circuit source to destination.
DELETING	CTC is deleting a circuit.

Table 11-2 ONS 15454 Circuit Status (continued)

Status	Definition/Activity
PARTIAL	<p>A CTC-created circuit is missing a cross-connect or network span, a complete path from source to destinations does not exist, or an alarm interface panel (AIP) change occurred on one of the circuit nodes and the circuit is in need of repair. (AIPs store the node MAC address.)</p> <p>In CTC, circuits are represented using cross-connects and network spans. If a network span is missing from a circuit, the circuit status is PARTIAL. However, a PARTIAL status does not necessarily mean a circuit traffic failure has occurred, because traffic might flow on a protect path.</p> <p>Network spans are in one of two states: up or down. On CTC circuit and network maps, up spans appear as green lines, and down spans appear as gray lines. If a failure occurs on a network span during a CTC session, the span remains on the network map but its color changes to gray to indicate that the span is down. If you restart your CTC session while the failure is active, the new CTC session cannot discover the span and its span line does not appear on the network map.</p> <p>Subsequently, circuits routed on a network span that goes down appear as DISCOVERED during the current CTC session, but appear as PARTIAL to users who log in after the span failure.</p>
DISCOVERED_TL1	A TL1-created circuit or a TL1-like, CTC-created circuit is complete. A complete path from source to destinations exists.
PARTIAL_TL1	A TL1-created circuit or a TL1-like, CTC-created circuit is missing a cross-connect or circuit span (network link), and a complete path from source to destinations does not exist.
CONVERSION_PENDING	An existing circuit in a topology upgrade is set to this state. The circuit returns to the DISCOVERED state once the topology upgrade is complete. For more information about topology upgrades, see Chapter 12, “SONET Topologies and Upgrades.”
PENDING_MERGE	Any new circuits created to represent an alternate path in a topology upgrade are set to this status to indicate that it is a temporary circuit. These circuits can be deleted if a topology upgrade fails. For more information about topology upgrades, see Chapter 12, “SONET Topologies and Upgrades.”
DROP_PENDING	A circuit is set to this status when a new circuit drop is being added.
ROLL_PENDING	A circuit roll is awaiting completion or cancellation.

11.2.3 Circuit States

The circuit service state is an aggregate of the cross-connect states within the circuit.

- If all cross-connects in a circuit are in the In-Service and Normal (IS-NR) service state, the circuit service state is In-Service (IS).

- If all cross-connects in a circuit are in an Out-of-Service (OOS) service state, such as Out-of-Service and Management, Maintenance (OOS-MA,MT); Out-of-Service and Management, Disabled (OOS-MA,DSBLD); or Out-of-Service and Autonomous, Automatic In-Service (OOS-AU,AINS) service state, the circuit service state is Out-of-Service (OOS).
- PARTIAL is appended to the OOS circuit service state when circuit cross-connects state are mixed and not all in IS-NR. The OOS-PARTIAL state can occur during automatic or manual transitions between states. For example, OOS-PARTIAL appears if you assign the IS,AINS administrative state to a circuit with DS-1 or DS3XM cards as the source or destination. Some cross-connects transition to the IS-NR service state, while others transition to OOS-AU,AINS. OOS-PARTIAL can appear during a manual transition caused by an abnormal event such as a CTC crash or communication error, or if one of the cross-connects could not be changed. Refer to the *Cisco ONS 15454 Troubleshooting Guide* for troubleshooting procedures. The OOS-PARTIAL circuit state does not apply to OCHNC circuit types.

You can assign a state to circuit cross-connects at two points:

- During circuit creation, you can set the state in the Create Circuit wizard.
- After circuit creation, you can change a circuit state in the Edit Circuit window or from the Tools > Circuits > Set Circuit State menu.



Note

After you have created an initial circuit in a CTC session, the subsequent circuit states default to the circuit state of the initial circuit, regardless of which nodes in the network the circuits traverse or the node.ckt.state default setting.

During circuit creation, you can apply a service state to the drop ports in a circuit; however, CTC does not apply a requested state other than IS-NR to drop ports if:

- The port is a timing source.
- The port is provisioned for orderwire or tunnel orderwire.
- The port is provisioned as a DCC or DCC tunnel.
- The port supports 1+1 or bidirectional line switched rings (BLSRs).

Circuits do not use the soak timer, but ports do. The soak period is the amount of time that the port remains in the OOS-AU,AINS service state after a signal is continuously received. When the cross-connects in a circuit are in the OOS-AU,AINS service state, the ONS 15454 monitors the cross-connects for an error-free signal. It changes the state of the circuit from OOS to IS or to OOS-PARTIAL as each cross-connect assigned to the circuit path is completed. This allows you to provision a circuit using TL1, verify its path continuity, and prepare the port to go into service when it receives an error-free signal for the time specified in the port soak timer. Two common examples of state changes you see when provisioning circuits using CTC are:

- When assigning the IS,AINS administrative state to cross-connects in VT circuits and VT tunnels, the source and destination ports on the VT circuits remain in the OOS-AU,AINS service state until an alarm-free signal is received for the duration of the soak timer. When the soak timer expires and an alarm-free signal is found, the VT source port and destination port service states change to IS-NR and the circuit service state becomes IS.
- When assigning the IS,AINS administrative state to cross-connects in STS circuits, the circuit source and destination ports transition to the OOS-AU,AINS service state. When an alarm-free signal is received, the source and destination ports remain OOS-AU,AINS for the duration of the soak timer. After the port soak timer expires, STS source and destination ports change to IS-NR and the circuit service state changes to IS.

To find the remaining port soak time, choose the Maintenance > AINS Soak tabs in card view and click the Retrieve button. If the port is in the OOS-AU,AINS state and has a good signal, the Time Until IS column shows the soak count down status. If the port is OOS-AU,AINS and has a bad signal, the Time Until IS column indicates that the signal is bad. You must click the Retrieve button to obtain the latest time value.

For more information about port and cross-connect states, see [Appendix B, “Administrative and Service States.”](#)

11.2.4 Circuit Protection Types

The Protection column in the Circuit window shows the card (line) and SONET topology (path) protection used for the entire circuit path. [Table 11-3](#) shows the protection type indicators that appear in this column.

Table 11-3 *Circuit Protection Types*

Protection Type	Description
1+1	The circuit is protected by a 1+1 protection group.
2F BLSR	The circuit is protected by a two-fiber BLSR.
4F BLSR	The circuit is protected by a four-fiber BLSR.
2F-PCA	The circuit is routed on a protection channel access (PCA) path on a two-fiber BLSR. PCA circuits are unprotected.
4F-PCA	The circuit is routed on a PCA path on a four-fiber BLSR. PCA circuits are unprotected.
BLSR	The circuit is protected by both a two-fiber and a four-fiber BLSR.
DRI	The circuit is protected by a dual-ring interconnection (DRI).
N/A	A circuit with connections on the same node is not protected.
PCA	The circuit is routed on a PCA path on both two-fiber and four-fiber BLSRs. PCA circuits are unprotected.
Protected	The circuit is protected by diverse SONET topologies, for example, a BLSR and a path protection, or a path protection and 1+1 protection.
Unknown	A circuit has a source and destination on different nodes and communication is down between the nodes. This protection type appears if not all circuit components are known.
Unprot (black)	A circuit with a source and destination on different nodes is not protected.
Unprot (red)	A circuit created as a fully protected circuit is no longer protected due to a system change, such as removal of a BLSR or 1+1 protection group.
Path Protection	The circuit is protected by a path protection.
SPLITTER	The circuit is protected by the protect transponder (TXPP_MR_2.5G) splitter protection. For splitter information, refer to the <i>Cisco ONS 15454 DWDM Installation and Operations Guide</i> .
Y-Cable	The circuit is protected by a transponder or muxponder card Y-cable protection group. For more information, refer to the <i>Cisco ONS 15454 DWDM Installation and Operations Guide</i> .

11.2.5 Circuit Information in the Edit Circuit Window

You can edit a selected circuit using the Edit button on the Circuits window. The tabs that appear depend on the circuit chosen:

- **General**—Displays general circuit information and allows you to edit the circuit name.
- **Drops**—Allows you to add a drop to a unidirectional circuit. For more information, see the [“11.7 Multiple Destinations for Unidirectional Circuits”](#) section on page 11-18.
- **Monitors**—Displays possible monitor sources and allows you to create a monitor circuit. For more information, see the [“11.8 Monitor Circuits”](#) section on page 11-19.
- **UPSR Selectors**—Allows you to change path protection selectors. For more information, see the [“11.9 Path Protection Circuits”](#) section on page 11-19.
- **UPSR Switch Counts**—Allows you to change path protection switch protection paths. For more information, see the [“11.9 Path Protection Circuits”](#) section on page 11-19.
- **State**—Allows you to edit cross-connect service states.
- **Merge**—Allows you to merge aligned circuits. For more information, see the [“11.19 Merged Circuits”](#) section on page 11-42.

Using the Export command from the File menu, you can export data from the UPSR Selectors, UPSR Switch Counts, State, and Merge tabs in HTML, comma-separated values (CSV), or tab-separated values (TSV) format.

The Show Detailed Map checkbox in the Edit Circuit window updates the graphical view of the circuit to show more detailed routing information, such as:

- Circuit direction (unidirectional/bidirectional)
- The nodes, STSs, and VTs through which a circuit passes, including slots and port numbers
- The circuit source and destination points
- Open Shortest Path First (OSPF) area IDs
- Link protection (path protection, unprotected, BLSR, 1+1) and bandwidth (OC-N)
- Provisionable patchcords between two cards on the same node or different nodes

For BLSRs, the detailed map shows the number of BLSR fibers and the BLSR ring ID. For path protection configurations, the map shows the active and standby paths from circuit source to destination, and it also shows the working and protect paths. Selectors appear as pentagons on the detailed circuit map. The map indicates nodes set up as DRI nodes. For VCAT circuits, the detailed map is not available for an entire VCAT circuit. However, you can view the detailed map to see the circuit route for each individual member.

You can also view alarms and states on the circuit map, including:

- Alarm states of nodes on the circuit route
- Number of alarms on each node organized by severity
- Port service states on the circuit route
- Alarm state/color of most severe alarm on port
- Loopbacks
- Path trace states
- Path selector states

By default, the working path is indicated by a green, bidirectional arrow, and the protect path is indicated by a purple, bidirectional arrow. Source and destination ports are shown as circles with an S and D. Port states are indicated by colors, shown in [Table 11-4](#).

Table 11-4 Port State Color Indicators

Port Color	Service State
Green	IS-NR
Gray	OOS-MA,DSBLD
Violet	OOS-AU,AINS
Blue (Cyan)	OOS-MA,MT

In detailed view, a notation within or by the squares or selector pentagons indicates switches and loopbacks, including:

- F = Force switch
- M = Manual switch
- L = Lockout switch
- Arrow = Facility (outward) or terminal (inward) loopback

Move the mouse cursor over nodes, ports, and spans to see tooltips with information including the number of alarms on a node (organized by severity), the port service state, and the protection topology.

Right-click a node, port, or span on the detailed circuit map to initiate certain circuit actions:

- Right-click a unidirectional circuit destination node to add a drop to the circuit.
- Right-click a port containing a path-trace-capable card to initiate the path trace.
- Right-click a path protection span to change the state of the path selectors in the path protection circuit.

[Figure 11-2](#) shows a circuit routed on a two-fiber BLSR. A port is shown in terminal loopback.

Figure 11-2 BLSR Circuit Displayed on the Detailed Circuit Map

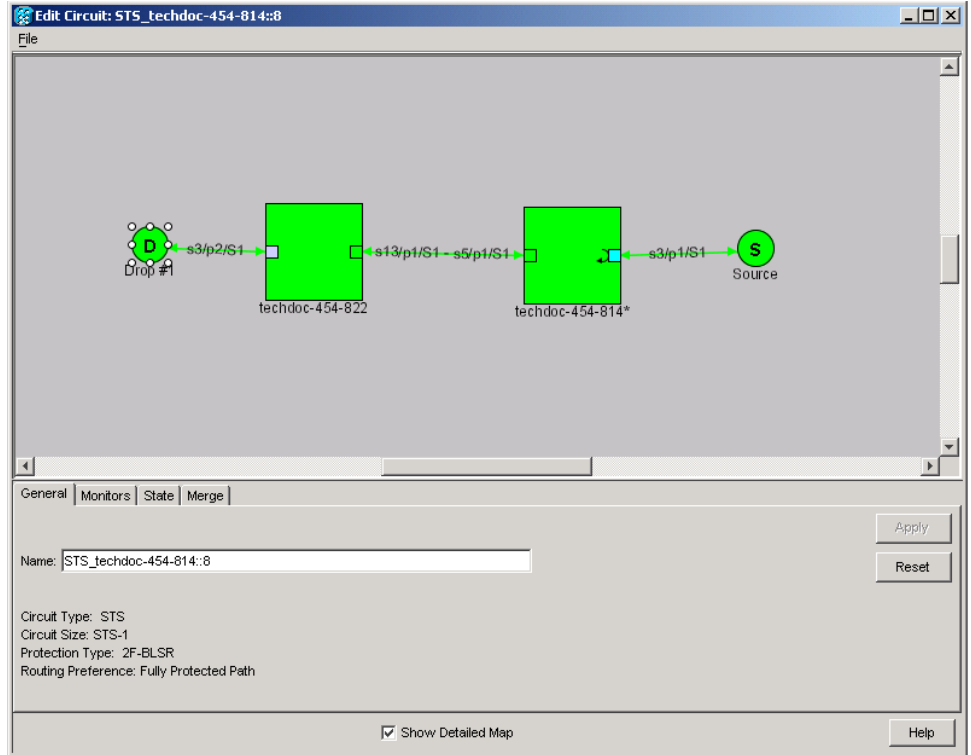

11.3 Cross-Connect Card Bandwidth

The ONS 15454 XCVT, XC10G, and XC-VXC-10G cross-connect cards perform port-to-port, time-division multiplexing (TDM). XCVT, XC10G, and XC-VXC-10G cards perform STS, VT2 (XC-VXC-10G only), and VT1.5 multiplexing.

The STS matrix on the XCVT cross-connect card has a capacity for 288 STS terminations, and the XC10G and XC-VXC-10G cards each have a capacity for 1152 STS terminations. Because each STS circuit requires a minimum of two terminations, one for ingress and one for egress, the XCVT card has a capacity for 144 STS circuits, while the XC10G and XC-VXC-10G cards have a capacity for 576 STS circuits. However, this capacity is reduced at path protection and 1+1 nodes because three STS terminations are required at circuit source and destination nodes and four terminations are required at 1+1 circuit pass-through nodes. path protection pass-through nodes only require two STS terminations.

The XCVT and XC10G cards perform VT1.5 multiplexing through 24 logical STS ports on the XCVT or XC10G VT matrix, and the XC-VXC-10G card performs VT1.5 and VT2 multiplexing through 96 logical STS ports on the XC-VXC-10G VT matrix. Each logical STS port can carry 28 VT1.5s or 21 VT2s. Subsequently, the VT matrix on the XCVT or XC10G has capacity for 672 VT1.5 terminations, or 336 VT1.5 circuits. The VT matrix on the XC-VXC-10G has capacity for 2688 VT1.5 terminations (1344 VT1.5 bidirectional circuits) or 2016 VT2 terminations (1008 VT2 bidirectional circuits). Every circuit requires two terminations, one for ingress and one for egress. However, this capacity is only achievable if:

- Every STS port on the VT matrix carries 28 VT1.5s or 21 VT2s.
- The node is in a BLSR or 1+1 protection scheme.

For example, if you create a VT1.5 circuit from an STS-1 on a drop card, two VT matrix STS ports are used, as shown in Figure 11-3. If you create a second VT1.5 circuit from the same STS port on the drop card, no additional logical STS ports are used on the VT matrix. In fact, you can create up to 28 VT1.5 circuits using the same STS-1 port. However, if the next VT1.5 circuit originates on a different STS, an additional pair of STS ports on the VT matrix is used, as shown in Figure 11-4. If you continued to create VT1.5 circuits on different EC-1 STSs and mapped each to an unused outbound STS, the VT matrix capacity would be reached after you created 12 VT1.5 circuits in the case of the XCVT or XC10G cards, or 48 VT1.5 circuits in the case of the XC-VXC-10G card.

Figure 11-3 One VT1.5 Circuit on One STS

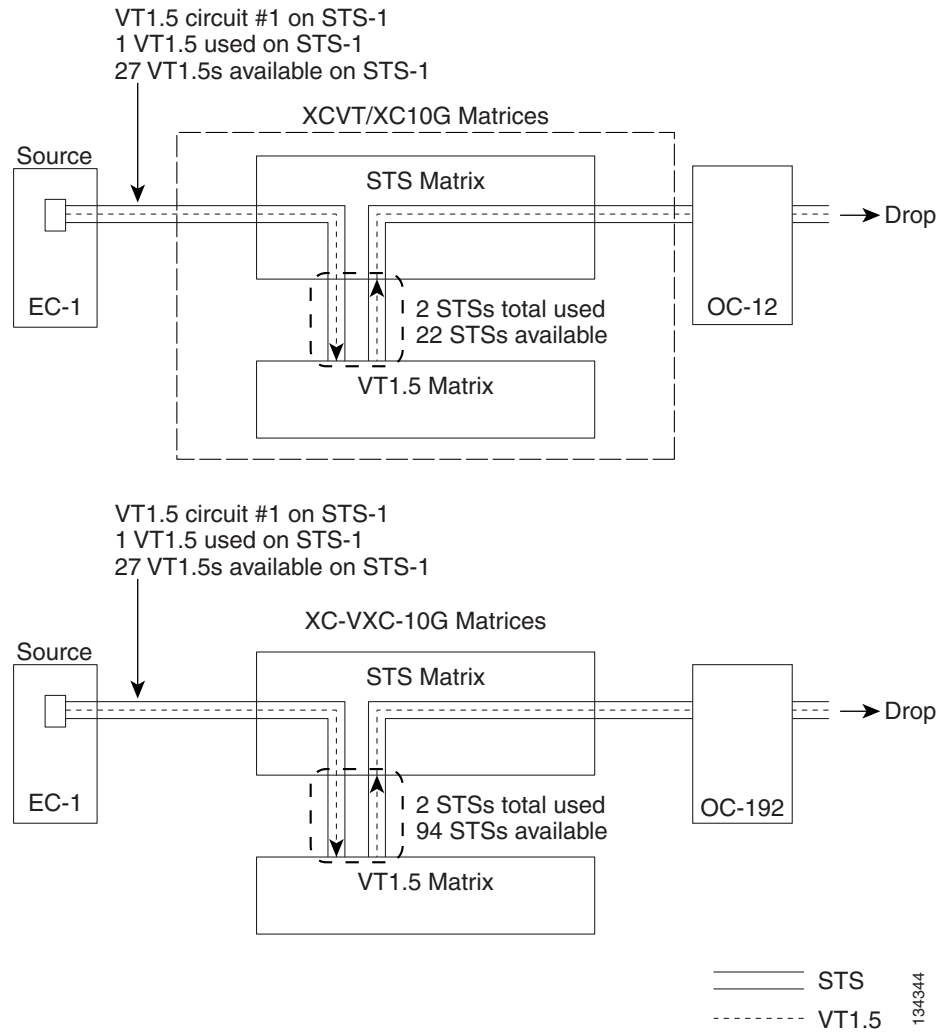
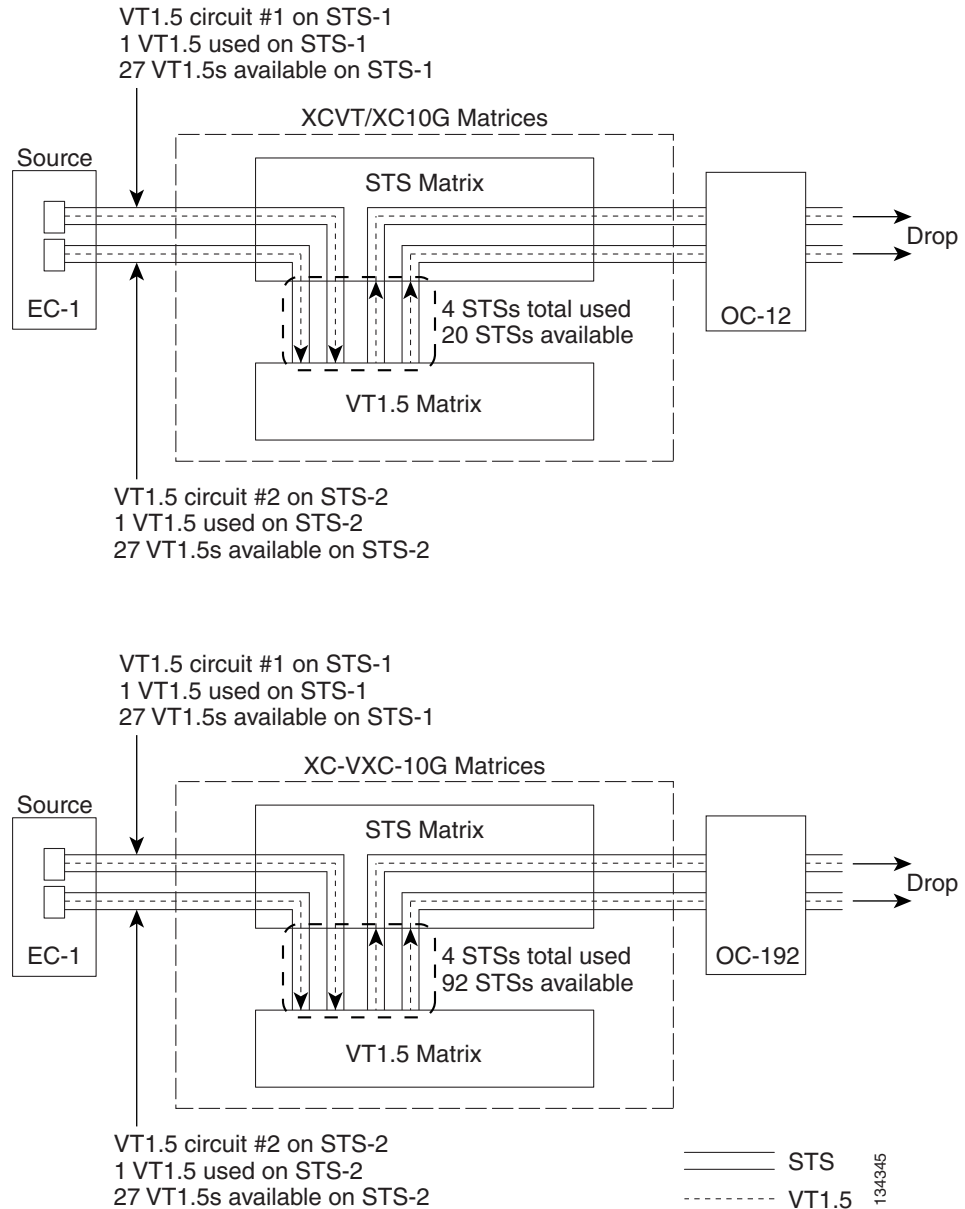

Figure 11-4 Two VT1.5 Circuits in a BLSR

**Note**

Circuits with DS1-14 and DS1N-14 circuit sources or destinations use one STS port on the VT matrix. Because you can only create 14 VT1.5 circuits from the DS-1 cards, 14 VT1.5s are unused on the VT matrix.

VT matrix capacity is also affected by SONET protection topology and node position within the circuit path. Matrix usage is slightly higher for path protection nodes than BLSR and 1+1 nodes. Circuits use two VT matrix ports at pass-through nodes if VT tunnels and aggregation points are not used. If the circuit is routed on a VT tunnel or an aggregation point, no VT matrix resources are used. [Table 11-5](#) shows basic STS port usage rates for VT 1.5 circuits.

Table 11-5 VT Matrix Port Usage for One VT1.5 Circuit

Node Type	No Protection	BLSR	Path Protection	1+1
Circuit source or destination node	2	2	3	2
Circuit pass-through node without VT tunnel	2	2	2	2
Circuit pass-through node with VT tunnel	0	0	0	0

Cross-connect card resources can be viewed on the Maintenance > Cross-Connect > Resource Usage tab. This tab shows:

- **STS-1 Matrix**—The percent of STS matrix resources that are used. 288 STSs are available on XCVT cards; 1152 are available on XC10G and XC-VXC-10G cards.
- **VT Matrix Ports**—The percent of the VT matrix ports (logical STS ports) that are used. 24 ports are available on XCVT and XC10G cards. 96 ports are available on the XC-VXC-10G card. The VT Port Matrix Detail shows the percent of each VT matrix port that is used.
- **VT Matrix**—The percent of the total VT matrix terminations that are used. There are 672 terminations for the XCVT and XC10G cards. 672 is the number of logical STS VT matrix ports (24) multiplied by the number of VT1.5s per port (28). There are 2688 terminations for the XC-VXC-10G card. 2688 is the number of logical STS VT matrix ports (96) multiplied by the number of VT1.5s per port (28).

To maximize resources on the cross-connect card VT matrix, keep the following points in mind as you provision circuits:

- Use all 28 VT1.5s on a given port or STS before moving to the next port or STS.
- Try to use EC-1, DS3XM, or OC-N cards as the VT1.5 circuit source and destination. VT1.5 circuits with DS-1-14 or DS1N-14 sources or destinations use a full port on the VT matrix even though only 14 VT1.5 circuits can be created.
- Use VT tunnels and VT aggregation points to reduce VT matrix utilization. VT tunnels allow VT1.5 circuits to bypass the VT matrix on pass-through nodes. They are cross-connected as STSs and only go through the STS matrix. VT aggregation points allow multiple VT1.5 circuits to be aggregated onto a single STS to bypass the VT matrix at the aggregation node.

11.4 Portless Transmux

The DS3XM-12 card provides a portless transmux interface to change DS-3s into VT1.5s. For XCVT drop slots, the DS3XM-12 card provides a maximum of 6 portless transmux interfaces; for XCVT trunk slots and XC10G or XC-VXC-10G slots, the DS3XM-12 card provides a maximum of 12 portless transmux interfaces. If two ports are configured as portless transmux, CTC allows you to create a DS3/STS1 circuit using one of these ports as the circuit end point. You can create separate DS1/VT1.5 circuits (up to 28) using the other port in this portless transmux pair.

When creating a circuit through the DS3XM-12 card, the portless pair blocks the mapped physical port(s); CTC does not display a blocked physical port in the source or destination drop-down list during circuit creation. [Table 11-6](#) lists the portless transmux mapping for XCVT drop ports.

Table 11-6 Portless Transmux Mapping for XCVT Drop Ports

Physical Port	Portless Port Pair
1, 2	13, 14
3, 4	15, 16
5, 6	17, 18
7, 8	19, 20
9, 10	21, 22
11, 12	23, 24

Table 11-7 lists the portless transmux for XCVT trunk ports and for XC10G or XC-VXC-10G any-slot ports.

Table 11-7 Portless Transmux Mapping for XCVT Trunk and XC10G or XC-VXC-10G Any-Slot Ports

Physical Port	Portless Port Pair
1	13, 14
2	25, 26
3	15, 16
4	27, 28
5	17, 18
6	29, 30
7	19, 20
8	31, 32
9	21, 22
10	33, 34
11	23, 24
12	35, 36

11.5 DCC Tunnels

SONET provides four DCCs for network element (NE) operation, administration, maintenance, and provisioning (OAM&P): one on the SONET Section layer (DCC1) and three on the SONET Line layer (DCC2, DCC3, and DCC4). The ONS 15454 uses the Section DCC (SDCC) for ONS 15454 management and provisioning. An SDCC and Line DCC (LDCC) each provide 192 Kbps of bandwidth per channel. The aggregate bandwidth of the three LDCCs is 576 Kbps. When multiple DCC channels exist between two neighboring nodes, the ONS 15454 balances traffic over the existing DCC channels using a load balancing algorithm. This algorithm chooses a DCC for packet transport by considering packet size and DCC utilization. You can tunnel third-party SONET equipment across ONS 15454 networks using one of two tunneling methods: a traditional DCC tunnel or an IP-encapsulated tunnel.

11.5.1 Traditional DCC Tunnels

In traditional DCC tunnels, you can use the three LDCCs and the SDCC (when not used for ONS 15454 DCC terminations). A traditional DCC tunnel endpoint is defined by slot, port, and DCC, where DCC can be either the SDCC or one of the LDCCs. You can link LDCCs to LDCCs and link SDCCs to SDCCs. You can also link an SDCC to an LDCC, and an LDCC to an SDCC. To create a DCC tunnel, you connect the tunnel endpoints from one ONS 15454 optical port to another. Cisco recommends a maximum of 84 DCC tunnel connections for an ONS 15454. [Table 11-8](#) shows the DCC tunnels that you can create using different OC-N cards.

Table 11-8 DCC Tunnels

Card	DCC	SONET Layer	SONET Bytes
OC3 IR 4/STM1 SH 1310	DCC1	Section	D1 - D3
OC3 IR/STM1 SH 1310-8; all OC-12, OC-48, and OC-192 cards	DCC1	Section	D1 - D3
	DCC2	Line	D4 - D6
	DCC3	Line	D7 - D9
	DCC4	Line	D10 - D12

[Figure 11-5](#) shows a DCC tunnel example. Third-party equipment is connected to OC-3 cards at Node 1/Slot 3/Port 1 and Node 3/Slot 3/Port 1. Each ONS 15454 node is connected by OC-48 trunk (span) cards. In the example, three tunnel connections are created, one at Node 1 (OC-3 to OC-48), one at Node 2 (OC-48 to OC-48), and one at Node 3 (OC-48 to OC-3).

Figure 11-5 Traditional DCC Tunnel

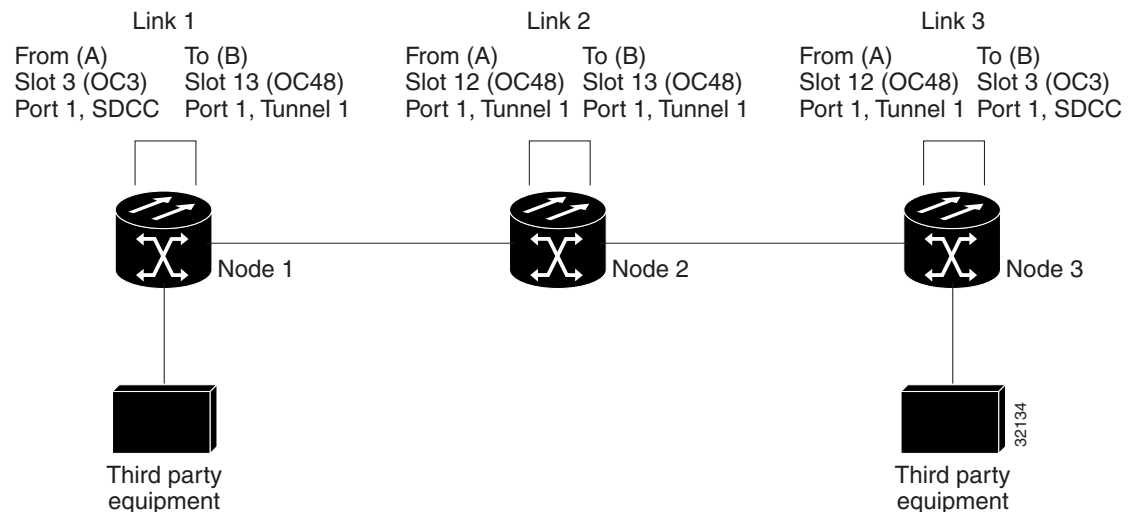

When you create DCC tunnels, keep the following guidelines in mind:

- Each ONS 15454 can have up to 84 DCC tunnel connections.
- Each ONS 15454 can have up to 84 Section DCC terminations.

- A SDCC that is terminated cannot be used as a DCC tunnel endpoint.
- A SDCC that is used as an DCC tunnel endpoint cannot be terminated.
- All DCC tunnel connections are bidirectional.

11.5.2 IP-Encapsulated Tunnels

An IP-encapsulated tunnel puts an SDCC in an IP packet at a source node and dynamically routes the packet to a destination node. To compare traditional DCC tunnels with IP-encapsulated tunnels, a traditional DCC tunnel is configured as one dedicated path across a network and does not provide a failure recovery mechanism if the path is down. An IP-encapsulated tunnel is a virtual path, which adds protection when traffic travels between different networks.

IP-encapsulated tunneling has the potential of flooding the DCC network with traffic resulting in a degradation of performance for CTC. The data originating from an IP tunnel can be throttled to a user-specified rate, which is a percentage of the total SDCC bandwidth.

Each ONS 15454 supports up to ten IP-encapsulated tunnels. You can convert a traditional DCC tunnel to an IP-encapsulated tunnel or an IP-encapsulated tunnel to a traditional DCC tunnel. Only tunnels in the DISCOVERED status can be converted.



Caution

Converting from one tunnel type to the other is service-affecting.

11.6 SDH Tunneling

The Cisco ONS 15454 SONET MSPP provides a SDH traffic transport solution with scalable SONET, data or DWDM multiservice capabilities. The SDH traffic is aggregated and transported across an ONS 15454 network, similar to the SONET TDM and data services. STM-1 to STM-64 payloads are transported over SONET from any port on a Cisco ONS 15454 OC-N card provisioned to support SDH signals. For more information on SDH tunneling, refer to the [SDH Tunneling Over Cisco ONS 15454 SONET MSPP Systems](#) Application Note.

11.7 Multiple Destinations for Unidirectional Circuits

Unidirectional circuits can have multiple destinations for use in broadcast circuit schemes. In broadcast scenarios, one source transmits traffic to multiple destinations, but traffic is not returned to the source.

When you create a unidirectional circuit, the card that does not have its backplane receive (Rx) input terminated with a valid input signal generates a loss of signal (LOS) alarm. To mask the alarm, create an alarm profile suppressing the LOS alarm and apply the profile to the port that does not have its Rx input terminated.

11.8 Monitor Circuits

Monitor circuits are secondary circuits that monitor traffic on primary bidirectional circuits. [Figure 11-6](#) shows an example of a monitor circuit. At Node 1, a VT1.5 is dropped from Port 1 of an EC1-12 card. To monitor the VT1.5 traffic, plug test equipment into Port 2 of the EC1-12 card and provision a monitor circuit to Port 2. Circuit monitors are one-way. The monitor circuit in [Figure 11-6](#) monitors VT1.5 traffic received by Port 1 of the EC1-12 card.

Figure 11-6 VT1.5 Monitor Circuit Received at an EC1-12 Port

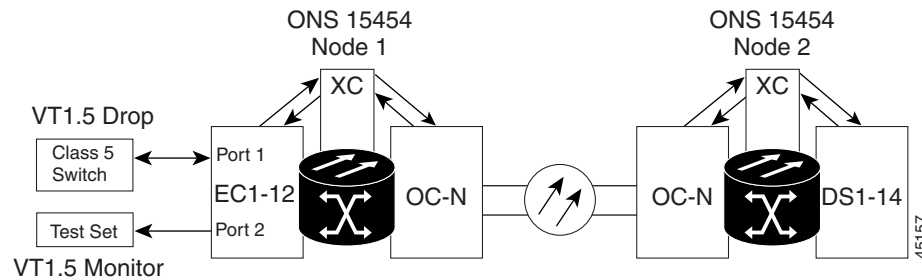

Note

Monitor circuits cannot be used with Ethernet circuits.

11.9 Path Protection Circuits

Use the Edit Circuits window to change path protection selectors and switch protection paths ([Figure 11-7](#)). In the UPSR Selectors subtab in the Edit Circuits window, you can:

- View the path protection circuit's working and protection paths.
- Edit the reversion time.
- Set the hold-off timer.
- Edit the Signal Fail/Signal Degrade thresholds.
- Change payload defect indication path (PDI-P) settings.



Note

The XC-VXC-10G cross-connect card supports VT switching based on SF and SD bit error rate (BER) thresholds. The XC10G and XCVT cross-connect cards do not support VT switching based on SF and SD BER thresholds, and hence, in the UPSR Selectors tab, the SF BER Level and SD BER Level columns display "N/A" for these cards.

In the UPSR Switch Counts subtab, you can:

- Perform maintenance switches on the circuit selector.
- View switch counts for the selectors.

Figure 11-7 Editing Path Protection Selectors

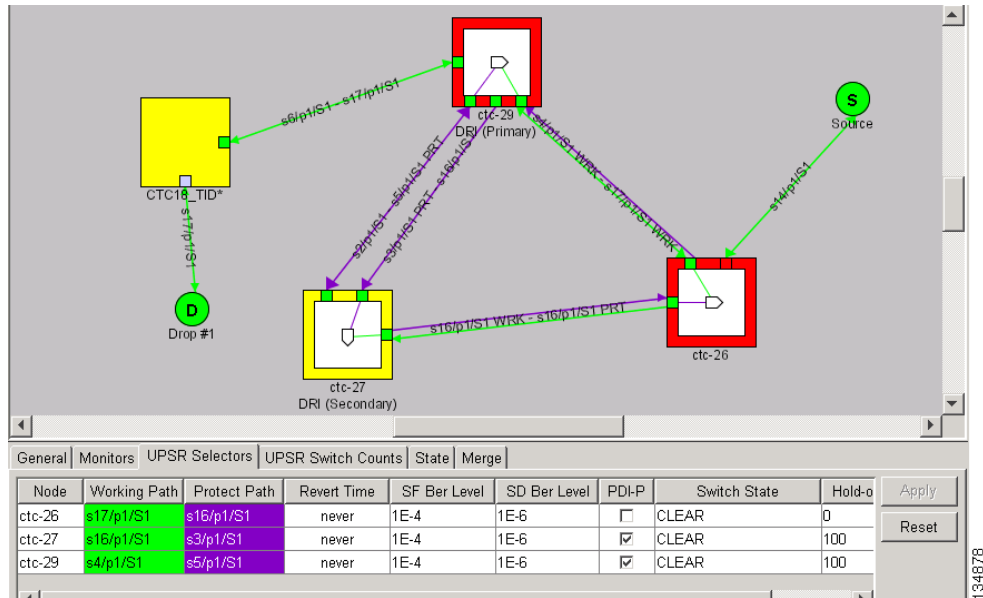

11.9.1 Open-Ended Path Protection Circuits

If ONS 15454s are connected to a third-party network, you can create an open-ended path protection circuit to route a circuit through it. To do this, you create four circuits. One circuit is created on the source ONS 15454 network. This circuit has one source and two destinations, each destination provisioned to the ONS 15454 interface that is connected to the third-party network. The second and third circuits are created on the third-party network so that the circuit travels across the network on two diverse paths to the far end ONS 15454. At the destination node, the fourth circuit is created with two sources, one at each node interface connected to the third-party network. A selector at the destination node chooses between the two signals that arrive at the node, similar to a regular path protection circuit.

11.9.2 Go-and-Return Path Protection Routing

The go-and-return path protection routing option allows you to route the path protection working path on one fiber pair and the protect path on a separate fiber pair (Figure 11-8). The working path will always be the shortest path. If a fault occurs, both the working and protection fibers are not affected. This feature only applies to bidirectional path protection circuits. The go-and-return option appears in the Circuit Attributes panel of the Circuit Creation wizard.

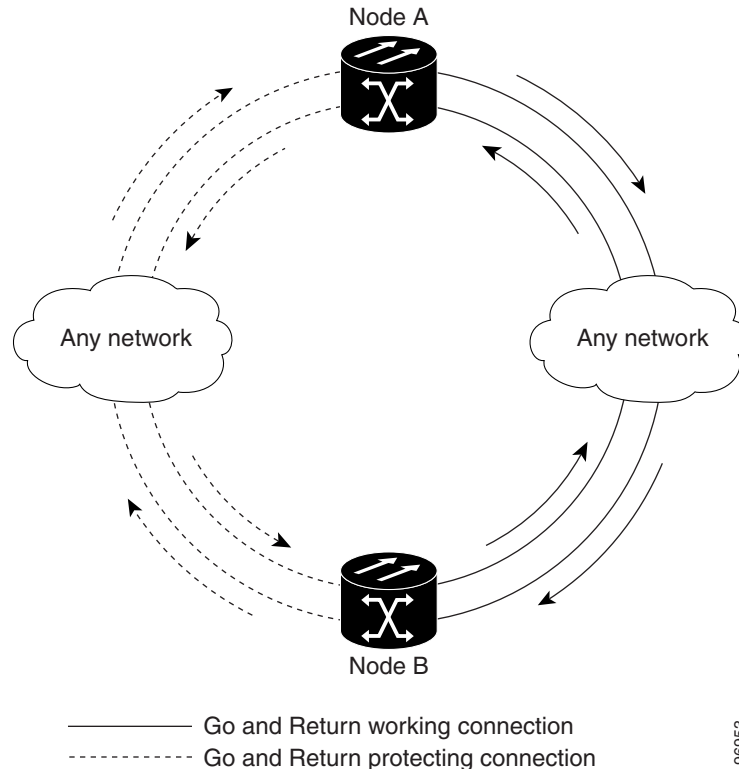
Figure 11-8 Path Protection Go-and-Return Routing

11.10 BLSR Protection Channel Access Circuits

You can provision circuits to carry traffic on BLSR protection channels when conditions are fault-free. Traffic routed on BLSR PCA circuits, called extra traffic, has lower priority than the traffic on the working channels and has no means for protection. During ring or span switches, PCA circuits are preempted and squelched. For example, in a two-fiber OC-48 BLSR, STSs 25 to 48 can carry extra traffic when no ring switches are active, but PCA circuits on these STSs are preempted when a ring switch occurs. When the conditions that caused the ring switch are remedied and the ring switch is removed, PCA circuits are restored. If the BLSR is provisioned as revertive, this occurs automatically after the fault conditions are cleared and the reversion timer has expired.

Traffic provisioning on BLSR protection channels is performed during circuit provisioning. The Protection Channel Access check box appears whenever Fully Protected Path is unchecked in the circuit creation wizard. Refer to the *Cisco ONS 15454 Procedure Guide* for more information. When provisioning PCA circuits, two considerations are important to keep in mind:

- If BLSRs are provisioned as nonrevertive, PCA circuits are not restored automatically after a ring or span switch. You must switch the BLSR manually.
- PCA circuits are routed on working channels when you upgrade a BLSR from a two-fiber to a four-fiber or from one optical speed to a higher optical speed. For example, if you upgrade a two-fiber OC-48 BLSR to an OC-192, STSs 25 to 48 on the OC-48 BLSR become working channels on the OC-192 BLSR.

11.11 BLSR STS and VT Squelch Tables

ONS 15454 nodes display STS and VT squelch tables depending on the type of circuits created. For example, if a fiber cut occurs, the BLSR squelch tables show STSs or VTs that will be squelched for every isolated node. Squelching replaces traffic by inserting the appropriate alarm indication signal path (AIS-P) and prevents traffic misconnections. For an STS with a VT-access check mark, the AIS-P will be removed after 100 ms. To view the squelch tables, refer to the “Manage Circuits” chapter in the *Cisco ONS 15454 Procedure Guide* for detailed instructions. For more information about BLSR squelching, refer to Telcordia GR-1230.

11.11.1 BLSR STS Squelch Table

BLSR STS squelch tables show STSs that will be squelched for every isolated node.

The BLSR Squelch Table window displays the following information:

- **STS Number**—Shows the BLSR STS numbers. For two-fiber BLSRs, the number of STSs is half the BLSR OC-N, for example, an OC-48 BLSR squelch table will show 24 STSs. For four-fiber BLSRs, the number of STSs in the table is the same as the BLSR OC-N.
- **West Source**—If traffic is received by the node on its west span, the BLSR node ID of the source appears. (To view the BLSR node IDs for all nodes in the ring, click the Ring Map button.)
- **West VT (from the West Source)** — A check mark indicates that the STS carries incoming VT traffic. The traffic source is coming from the west side.
- **West VT (from the West Destination)** — A check mark indicates that the STS carries outgoing VT traffic. The traffic is dropped on the west side.
- **West Dest**—If traffic is sent on the node’s west span, the BLSR node ID of the destination appears.
- **East Source**—If traffic is received by the node on its east span, the BLSR node ID of the source appears.
- **East VT — (from the East Source)** - A check mark indicates that the STS carries incoming VT traffic. The traffic source is coming from the east side.
- **East VT — (from the East Destination)** - A check mark indicate that the STS carries outgoing VT traffic. The traffic is dropped on the east side.
- **East Dest**—If traffic is sent on the node’s east span, the BLSR node ID of the destination appears.



Note

BLSR squelching is performed on STSs that carry STS circuits only. Squelch table entries will not appear for STSs carrying VT circuits or Ethernet circuits to or from E-Series Ethernet cards provisioned in a multicard Ethergroup.

11.11.2 BLSR VT Squelch Table

BLSR VT squelch tables only appear on the node dropping VTs from a BLSR and are used to perform VT-level squelching when a node is isolated. VT squelching is supported on the ONS 15454 and the ONS 15327 platforms. The ONS 15600 platform does not support VT squelching; however, when an ONS 15454 and an ONS 15600 are in the same network, the ONS 15600 node allows the ONS 15454 node to carry VT circuits in a VT tunnel. The ONS 15600 performs 100-ms STS-level squelching for each VT-access STS at the switching node in case of a node failure.

When using a VT circuit on a VT tunnel (VTT), the VTT allows multiple VT circuits to be passed through on a single STS without consuming VT matrix resources on the cross-connect card. Both endpoints of the VTT are the source and destination nodes for the VTT. The node carrying VT circuits through a VTT is called a VT-access node. In case of a source and destination node failure of the VTT, the switching node performs 100-ms STS-level squelching for the VTT STS. The node dropping VT traffic performs VT-level squelching. VT traffic on the VTT that is not coming from the failed node is protected.

When using a VT circuit on a VT aggregation point (VAP), the VAP allows multiple VT circuits to be aggregated into a single STS without consuming VT matrix resources on the cross-connect card. The source for each VAP STS timeslot is the STS-grooming end where VT1.5 circuits are aggregated into a single STS. The destination for each VAP STS is the VT-grooming end where VT1.5 circuits originated. The source node for each VT circuit on a VAP is the STS-grooming end where the VT1.5 circuits are aggregated into a single STS. The STS grooming node is not a VT-access node. The non VT-access node performs STS-level squelching for each STS timeslot at the switching node in case the VT-grooming node fails. The node dropping VT traffic performs VT-level squelching for each VT timeslot in case the STS-grooming end node fails. No VT traffic on the VAP is protected during a failure of the STS-grooming node or the VT-grooming node.

To view the VT squelch table, double-click the VT with a check mark in the BLSR STS squelch table window. The check mark appears on every VT-access STS; however, the VT-squelch table appears only by double-clicking the check mark on the node dropping the VT. The intermediate node of the VT does not maintain the VT-squelch table.

The VT squelch table provides the following information:

- **VT Number**—Shows the BLSR VT numbers. The VT number includes VT group number and VT number in group (VT group 2 and channel 1 are displayed as 2-1.)
- **West Source**—If traffic is received by the node on its west span, the BLSR node ID of the source appears. (To view the BLSR node IDs for all nodes in the ring, click the Ring Map button.)
- **East Source**—If traffic is received by the node on its east span, the BLSR node ID of the source appears.

11.12 Section and Path Trace

SONET J0 section and J1 and J2 path trace are repeated, fixed-length strings composed of 16 or 64 consecutive bytes. You can use the strings to monitor interruptions or changes to circuit traffic.

The OC192-XFP and MRC-12 cards support J0 section trace. [Table 11-9](#) shows the ONS 15454 cards that support J1 path trace. DS-1 and DS-3 cards can transmit and receive the J1 field, while the EC-1, OC-3, OC-48 AS, and OC-192 can only receive the J1 bytes. Cards that are not listed in the table do not support the J1 byte. The DS3XM-12 card supports J2 path trace for VT circuits.

Table 11-9 ONS 15454 Cards Capable of J1 Path Trace

J1 Function	Cards
Transmit and Receive	CE-Series DS1-14 ¹ DS1N-14 DS1/EC1-56 DS3-12E DS3i-N-12 DS3/EC1-48 DS3N-12E DS3XM-6 DS3XM-12 FC_MR-4 G-Series ML-Series
Receive Only	EC1-12 OC3 IR 4/STM1 SH 1310 OC3 IR 4/STM1 SH 1310-8 OC12/STM4-4 OC48 IR/STM16 SH AS 1310 OC48 LR/STM16 LH AS 1550 OC192 SR/STM64 IO 1310 OC192 LR/STM64 LH 1550 OC192 IR/STM SH 1550 OC192-XFP

1. J1 path trace is not supported for DS-1s used in VT circuits.

If the string received at a circuit drop port does not match the string the port expects to receive, an alarm is raised. Two path trace modes are available:

- Automatic—The receiving port assumes that the first string it receives is the baseline string.
- Manual—The receiving port uses a string that you manually enter as the baseline string.

11.13 Path Signal Label, C2 Byte

One of the overhead bytes in the SONET frame is the C2 byte. The SONET standard defines the C2 byte as the path signal label. The purpose of this byte is to communicate the payload type being encapsulated by the STS path overhead (POH). The C2 byte functions similarly to EtherType and Logical Link Control

(LLC)/Subnetwork Access Protocol (SNAP) header fields on an Ethernet network; it allows a single interface to transport multiple payload types simultaneously. C2 byte hex values are provided in [Table 11-10](#).

Table 11-10 STS Path Signal Label Assignments for Signals

Hex Code	Content of the STS Synchronous Payload Envelope (SPE)
0x00	Unequipped
0x01	Equipped - nonspecific payload
0x02	VT structured STS-1 (DS-1)
0x03	Locked VT mode
0x04	Asynchronous mapping for DS-3
0x12	Asynchronous mapping for DS4NA
0x13	Mapping for Asynchronous Transfer Mode (ATM)
0x14	Mapping for distributed queue dual bus (DQDB)
0x15	Asynchronous mapping for fiber distributed data interface (FDDI)
0x16	High-level data link control (HDLC) over SONET mapping
0x1B	Generic Frame Procedure (GFP) used by the FC_MR-4 and ML Series cards
0xFD	Reserved
0xFE	0.181 test signal (TSS1 to TSS3) mapping SDH network
0xFF	Alarm indication signal, path (AIS-P)

If a circuit is provisioned using a terminating card, the terminating card provides the C2 byte. A VT circuit is terminated at the XCVT, XC10G, or XC-VXC-10G card, which generates the C2 byte (0x02) downstream to the STS terminating cards. The XCVT, XC10G, or XC-VXC-10G card generates the C2 value (0x02) to the DS1 or DS3XM terminating card. If an optical circuit is created with no terminating cards, the test equipment must supply the path overhead in terminating mode. If the test equipment is in pass-through mode, the C2 values usually change rapidly between 0x00 and 0xFF. Adding a terminating card to an optical circuit usually fixes a circuit having C2 byte problems. [Table 11-11](#) lists label assignments for signals with payload defects.

Table 11-11 STS Path Signal Label Assignments for Signals with Payload Defects

Hex Code	Content of the STS SPE
0xE1	VT-structured STS-1 SPE with 1 VTx payload defect (STS-1 with 1 VTx PD)
0xE2	STS-1 with 2 VTx PDs
0xE3	STS-1 with 3 VTx PDs
0xE4	STS-1 with 4 VTx PDs
0xE5	STS-1 with 5 VTx PDs
0xE6	STS-1 with 6 VTx PDs
0xE7	STS-1 with 7 VTx PDs
0xE8	STS-1 with 8 VTx PDs
0xE9	STS-1 with 9 VTx PDs

Table 11-11 STS Path Signal Label Assignments for Signals with Payload Defects (continued)

Hex Code	Content of the STS SPE
0xEA	STS-1 with 10 VTx PDs
0xEB	STS-1 with 11 VTx PDs
0xEC	STS-1 with 12 VTx PDs
0xED	STS-1 with 13 VTx PDs
0xEE	STS-1 with 14 VTx PDs
0xEF	STS-1 with 15 VTx PDs
0xF0	STS-1 with 16 VTx PDs
0xF1	STS-1 with 17 VTx PDs
0xF2	STS-1 with 18 VTx PDs
0xF3	STS-1 with 19 VTx PDs
0xF4	STS-1 with 20 VTx PDs
0xF5	STS-1 with 21 VTx PDs
0xF6	STS-1 with 22 VTx PDs
0xF7	STS-1 with 23 VTx PDs
0xF8	STS-1 with 24 VTx PDs
0xF9	STS-1 with 25 VTx PDs
0xFA	STS-1 with 26 VTx PDs
0xFB	STS-1 with 27 VTx PDs
0xFC	VT-structured STS-1 SPE with 28 VT1.5 (Payload defects or a non-VT-structured STS-1 or STS-Nc SPE with a payload defect.)
0xFF	Reserved

11.14 Automatic Circuit Routing

If you select automatic routing during circuit creation, CTC routes the circuit by dividing the entire circuit route into segments based on protection domains. For unprotected segments of circuits provisioned as fully protected, CTC finds an alternate route to protect the segment, creating a virtual path protection. Each segment of a circuit path is a separate protection domain. Each protection domain is protected in a specific protection scheme including card protection (1+1, 1:1, etc.) or SONET topology (path protection, BLSR, etc.).

The following list provides principles and characteristics of automatic circuit routing:

- Circuit routing tries to use the shortest path within the user-specified or network-specified constraints. VT tunnels are preferable for VT circuits because VT tunnels are considered shortcuts when CTC calculates a circuit path in path-protected mesh networks.
- If you do not choose Fully Path Protected during circuit creation, circuits can still contain protected segments. Because circuit routing always selects the shortest path, one or more links and/or segments can have some protection. CTC does not look at link protection while computing a path for unprotected circuits.

- Circuit routing does not use links that are down. If you want all links to be considered for routing, do not create circuits when a link is down.
- Circuit routing computes the shortest path when you add a new drop to an existing circuit. It tries to find the shortest path from the new drop to any nodes on the existing circuit.
- If the network has a mixture of VT-capable nodes and VT-incapable nodes, CTC can automatically create a VT tunnel. Otherwise, CTC asks you whether a VT tunnel is needed.
- To create protected circuits between topologies, install an XCVT, XC10G, or XC-VXC-10G cross-connect card on the shared node.
- For STS circuits, you can use portless transmux interfaces if a DS3XM-12 card is installed in the network. CTC automatically routes the circuit over the portless transmux interfaces on the specified node creating an end-to-end STS circuit.

11.14.1 Bandwidth Allocation and Routing

Within a given network, CTC routes circuits on the shortest possible path between source and destination based on the circuit attributes, such as protection and type. CTC considers using a link for the circuit only if the link meets the following requirements:

- The link has sufficient bandwidth to support the circuit.
- The link does not change the protection characteristics of the path.
- The link has the required time slots to enforce the same time slot restrictions for BLSRs.

If CTC cannot find a link that meets these requirements, an error appears.

The same logic applies to VT circuits on VT tunnels. Circuit routing typically favors VT tunnels because VT tunnels are shortcuts between a given source and destination. If the VT tunnel in the route is full (no more bandwidth), CTC asks whether you want to create an additional VT tunnel.

11.14.2 Secondary Sources and Destinations

CTC supports secondary circuit sources and destinations (drops). Secondary sources and destinations typically interconnect two third-party networks, as shown in [Figure 11-9](#). Traffic is protected while it goes through a network of ONS 15454s.

Figure 11-9 Secondary Sources and Destinations

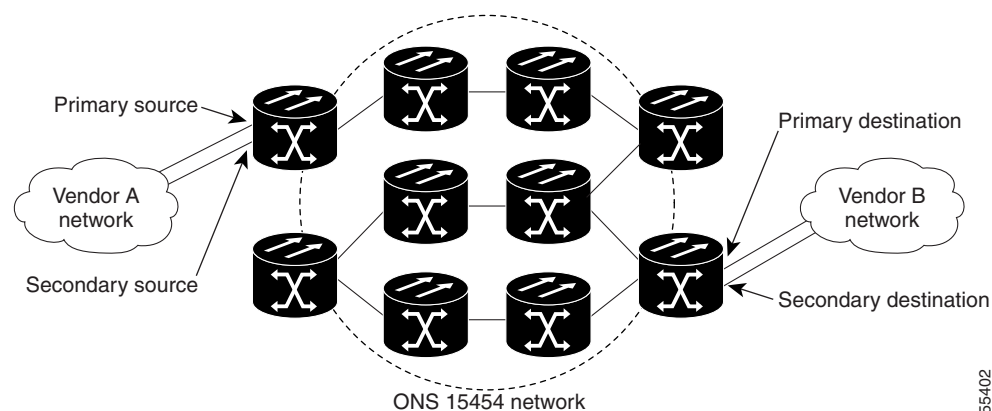

55402

Several rules apply to secondary sources and destinations:

- CTC does not allow a secondary destination for unidirectional circuits because you can always specify additional destinations after you create the circuit.
- The sources and destinations cannot be DS-3, DS3XM, or DS-1-based STS-1s or VT1.5s.
- Secondary sources and destinations are permitted only for regular STS/VT1.5 connections (not for VT tunnels and multicard EtherSwitch circuits).
- For point-to-point (straight) Ethernet circuits, only SONET STS endpoints can be specified as multiple sources or destinations.

For bidirectional circuits, CTC creates a path protection connection at the source node that allows traffic to be selected from one of the two sources on the ONS 15454 network. If you check the Fully Path Protected option during circuit creation, traffic is protected within the ONS 15454 network. At the destination, another path protection connection is created to bridge traffic from the ONS 15454 network to the two destinations. A similar but opposite path exists for the reverse traffic flowing from the destinations to the sources.

For unidirectional circuits, a path protection drop-and-continue connection is created at the source node.

11.15 Manual Circuit Routing

Routing circuits manually allows you to:

- Choose a specific path, not necessarily the shortest path.
- Choose a specific STS/VT1.5 on each link along the route.
- Create a shared packet ring for multicard EtherSwitch circuits.
- Choose a protected path for multicard EtherSwitch circuits, allowing virtual path protection segments.

CTC imposes the following rules on manual routes:

- All circuits, except multicard EtherSwitch circuits in a shared packet ring, should have links with a direction that flows from source to destination. This is true for multicard EtherSwitch circuits that are not in a shared packet ring.
- If you enabled Fully Path Protected, choose a diverse protect (alternate) path for every unprotected segment ([Figure 11-10](#)).

Figure 11-10 Alternate Paths for Virtual Path Protection Segments

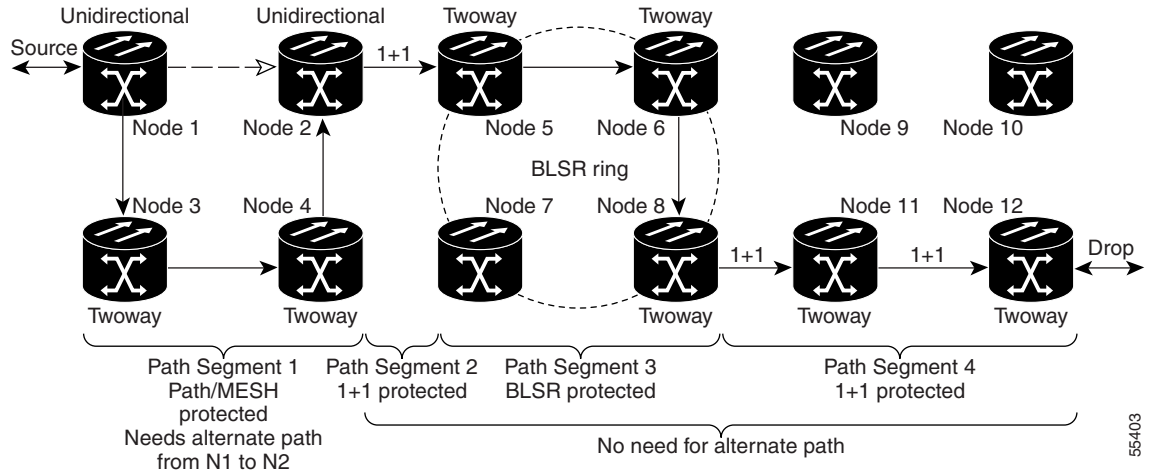

55403

- For multcard EtherSwitch circuits, the Fully Path Protected option is ignored.
- For a node that has a path protection selector based on the links chosen, the input links to the path protection selectors cannot be 1+1 or BLSR protected (Figure 11-11). The same rule applies at the path protection bridge.

Figure 11-11 Mixing 1+1 or BLSR Protected Links With a Path Protection

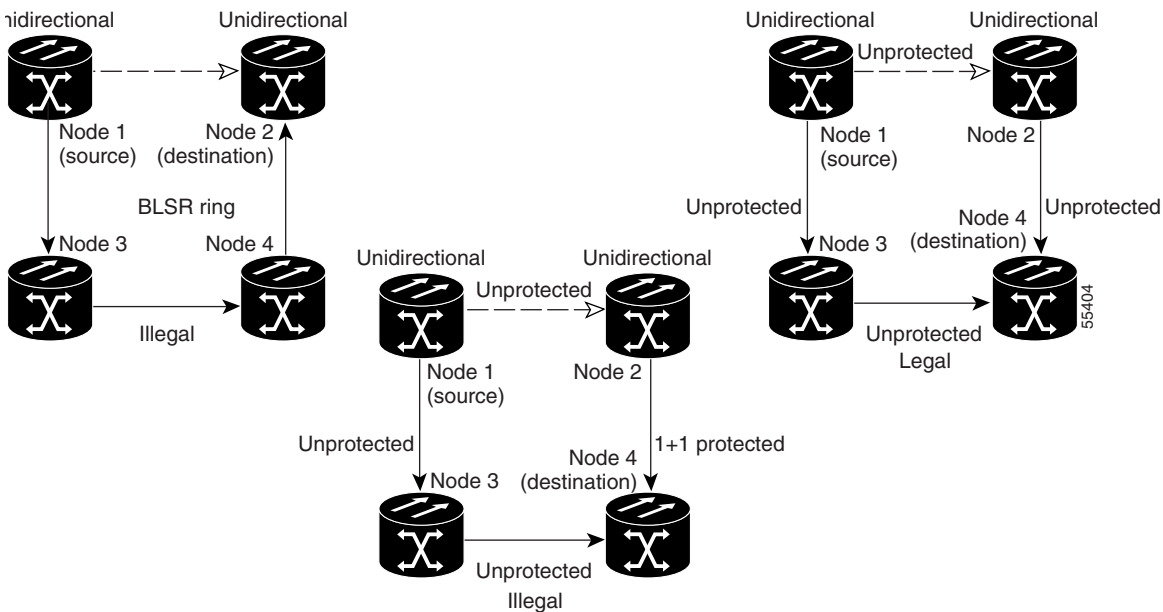

55404

- In a shared packet ring, choose the links of multcard EtherSwitch circuits to route from source to destination back to source (Figure 11-12). Otherwise, a route (set of links) chosen with loops is invalid.

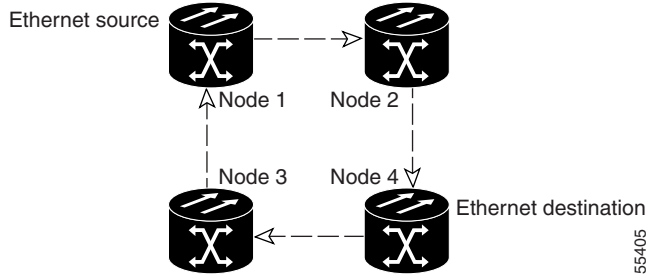
Figure 11-12 Ethernet Shared Packet Ring Routing

- Multicard EtherSwitch circuits can have virtual path protection segments if the source or destination is not in the path protection domain. This restriction also applies after circuit creation; therefore, if you create a circuit with path protection segments, Ethernet destinations cannot exist anywhere on the path protection segment (Figure 11-13).

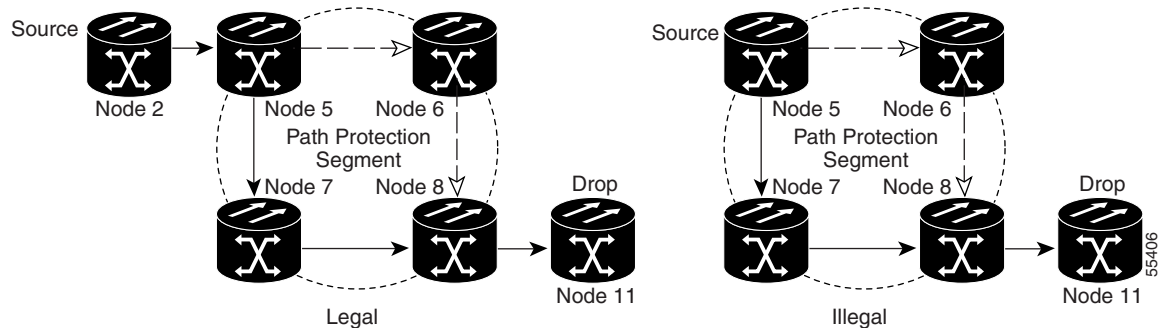
Figure 11-13 Ethernet and Path Protection

- A VT tunnel cannot be the endpoint of a path protection segment. A path protection segment endpoint is where the path protection selector resides.

If you provision full path protection, CTC verifies that the route selection is protected at all segments. A route can have multiple protection domains with each domain protected by a different scheme.

Table 11-12 through Table 11-15 on page 11-31 summarize the available node connections. Any other combination is invalid and generates an error.

Table 11-12 Bidirectional STS/VT/Regular Multicard EtherSwitch/Point-to-Point (Straight) Ethernet Circuits

Connection Type	Number of Inbound Links	Number of Outbound Links	Number of Sources	Number of Destinations
UPSR	—	2	1	—
UPSR	2	—	—	1
UPSR	2	1	—	—
UPSR	1	2	—	—
UPSR	1	—	—	2
UPSR	—	1	2	—
Double UPSR	2	2	—	—

Table 11-12 *Bidirectional STS/VT/Regular Multicard EtherSwitch/Point-to-Point (Straight) Ethernet Circuits (continued)*

Connection Type	Number of Inbound Links	Number of Outbound Links	Number of Sources	Number of Destinations
Double UPSR	2	—	—	2
Double UPSR	—	2	2	—
Two way	1	1	—	—
Ethernet	0 or 1	0 or 1	Ethernet node source	—
Ethernet	0 or 1	0 or 1	—	Ethernet node drop

Table 11-13 *Unidirectional STS/VT Circuit*

Connection Type	Number of Inbound Links	Number of Outbound Links	Number of Sources	Number of Destinations
One way	1	1	—	—
UPSR headend	1	2	—	—
UPSR headend	—	2	1	—
UPSR drop and continue	2	—	—	1+

Table 11-14 *Multicard Group Ethernet Shared Packet Ring Circuit*

Connection Type	Number of Inbound Links	Number of Outbound Links	Number of Sources	Number of Destinations
At Intermediate Nodes Only				
Double UPSR	2	2	—	—
Two way	1	1	—	—
At Source or Destination Nodes Only				
Ethernet	1	1	—	—

Table 11-15 *Bidirectional VT Tunnels*

Connection Type	Number of Inbound Links	Number of Outbound Links	Number of Sources	Number of Destinations
At Intermediate Nodes Only				
UPSR	2	1	—	—
UPSR	1	2	—	—
Double UPSR	2	2	—	—
Two way	1	1	—	—

Table 11-15 Bidirectional VT Tunnels (continued)

Connection Type	Number of Inbound Links	Number of Outbound Links	Number of Sources	Number of Destinations
At Source Nodes Only				
VT tunnel endpoint	—	1	—	—
At Destination Nodes Only				
VT tunnel endpoint	1	—	—	—

Although virtual path protection segments are possible in VT tunnels, VT tunnels are still considered unprotected. If you need to protect VT circuits, use two independent VT tunnels that are diversely routed or use a VT tunnel that is routed over 1+1, BLSR, or a mixture of 1+1 and BLSR links.

11.16 Constraint-Based Circuit Routing

When you create circuits, you can choose Fully Protected Path to protect the circuit from source to destination. The protection mechanism used depends on the path that CTC calculates for the circuit. If the network is composed entirely of BLSR or 1+1 links, or the path between source and destination can be entirely protected using 1+1 or BLSR links, no path-protected mesh network (PPMN), or virtual path protection, protection is used.

If PPMN protection is needed to protect the path, set the level of node diversity for the PPMN portions of the complete path in the Circuit Routing Preferences area of the Circuit Creation dialog box:

- **Nodal Diversity Required**—Ensures that the primary and alternate paths of each PPMN domain in the complete path have a diverse set of nodes.
- **Nodal Diversity Desired**—CTC looks for a node diverse path; if a node-diverse path is not available, CTC finds a link-diverse path for each PPMN domain in the complete path.
- **Link Diversity Only**—Creates only a link-diverse path for each PPMN domain.

When you choose automatic circuit routing during circuit creation, you have the option to require or exclude nodes and links in the calculated route. You can use this option to achieve the following results:

- **Simplify manual routing**, especially if the network is large and selecting every span is tedious. You can select a general route from source to destination and allow CTC to fill in the route details.
- **Balance network traffic**. By default, CTC chooses the shortest path, which can load traffic on certain links while other links have most of their bandwidth available. By selecting a required node and/or a link, you force the CTC to use (or not use) an element, resulting in more efficient use of network resources.

CTC considers required nodes and links to be an ordered set of elements. CTC treats the source nodes of every required link as required nodes. When CTC calculates the path, it makes sure that the computed path traverses the required set of nodes and links and does not traverse excluded nodes and links.

The required nodes and links constraint is only used during the primary path computation and only for PPMN domains/segments. The alternate path is computed normally; CTC uses excluded nodes/links when finding all primary and alternate paths on PPMNs.

11.17 Virtual Concatenated Circuits

Virtual concatenated (VCAT) circuits, also called VCAT groups (VCGs), transport traffic using noncontiguous TDM time slots, avoiding the bandwidth fragmentation problem that exists with contiguous concatenated (CCAT) circuits. The cards that support VCAT circuits are the CE-Series, FC_MR-4 (both line rate and enhanced mode), and ML-Series cards.

In a VCAT circuit, circuit bandwidth is divided into smaller circuits called VCAT members. The individual members act as independent TDM circuits. All VCAT members should be the same size and must originate and terminate at the same end points. For two-fiber BLSR configurations, some members can be routed on protected time slots and others on PCA time slots.

11.17.1 VCAT Circuit States

The state of a VCAT circuit is an aggregate of its member circuits. You can view whether a VCAT member is In Group or Out of Group in the VCAT State column in the Edit Circuits window.

- If all member circuits are in the IS state, the VCAT circuit state is IS.
- If all In Group member circuits are in the OOS state, the VCAT circuit state is OOS.
- If no member circuits exist or if all member circuits are Out of Group, the VCAT circuit state is OOS.
- A VCAT circuit is in OOS-PARTIAL state when In Group member states are mixed and not all are in the IS state.

11.17.2 VCAT Member Routing

The automatic and manual routing selection applies to the entire VCAT circuit, that is, all members are manually or automatically routed. Bidirectional VCAT circuits are symmetric, which means that the same number of members travel in each direction. With automatic routing, you can specify the constraints for individual members; with manual routing, you can select different spans for different members.

Two types of automatic and manual routing are available for VCAT members: common fiber routing and split routing. CE-Series, FC_MR-4 (both line rate and enhanced mode), and ML-Series cards support common fiber routing. In common fiber routing, all VCAT members travel on the same fibers, which eliminates delay between members. Three protection options are available for common fiber routing: Fully Protected, PCA, and Unprotected. [Figure 11-14](#) shows an example of common fiber routing.

Figure 11-14 VCAT Common Fiber Routing

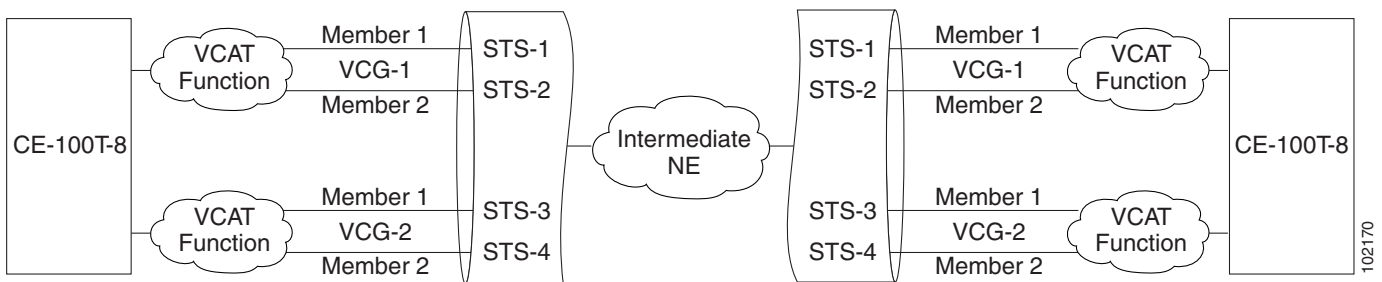

CE-Series cards also support split fiber routing, which allows the individual members to be routed on different fibers or each member to have different routing constraints. This mode offers the greatest bandwidth efficiency and also the possibility of differential delay, which is handled by the buffers on the terminating cards. Four protection options are available for split fiber routing: Fully Protected, PCA, Unprotected, and DRI. Figure 11-15 shows an example of split fiber routing.

Figure 11-15 VCAT Split Fiber Routing

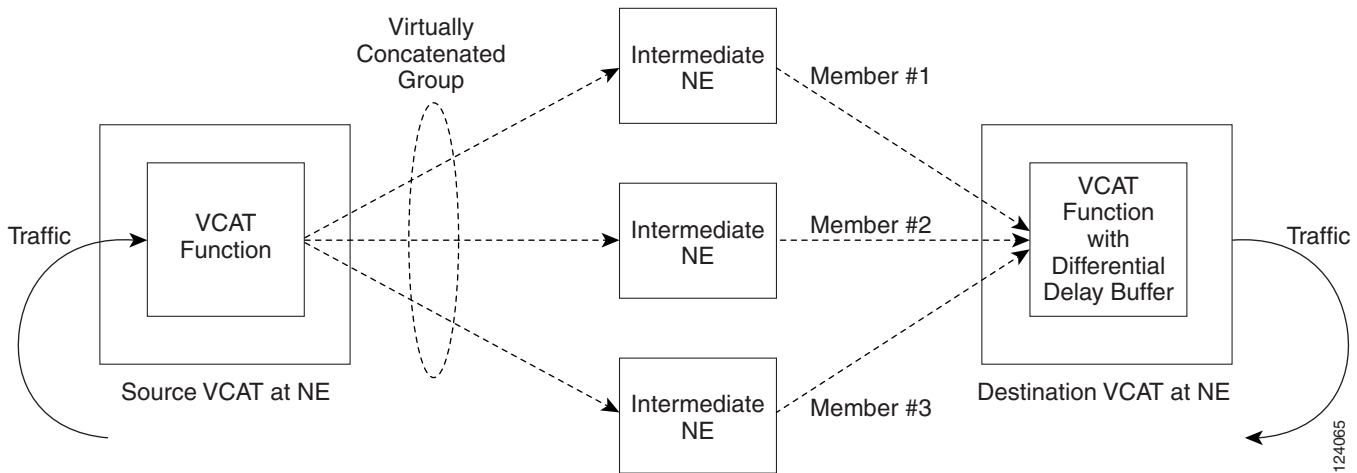

In both common fiber and split fiber routing, each member can use a different protection scheme; however, for common fiber routing, CTC checks the combination to make sure that a valid route exists. If it does not, the user must modify the protection type. In both common fiber and split fiber routing, intermediate nodes treat the VCAT members as normal circuits that are independently routed and protected by the SONET network. At the terminating nodes, these member circuits are multiplexed into a contiguous stream of data.

11.17.3 Link Capacity Adjustment

The CE-100T-8 card supports the link capacity adjustment scheme (LCAS), which is a signaling protocol that allows dynamic bandwidth adjustment of VCAT circuits. When a member fails, a brief traffic hit occurs. LCAS temporarily removes the failed member from the VCAT circuit for the duration of the failure, leaving the remaining members to carry the traffic. When the failure clears, the member circuit is automatically added back into the VCAT circuit without affecting traffic. You can select LCAS during VCAT circuit creation.



Note

Although LCAS operations are errorless, a SONET error can affect one or more VCAT members. If this occurs, the VCAT Group Degraded (VCG-DEG) alarm is raised. For information on clearing this alarm, refer to the *Cisco ONS 15454 Troubleshooting Guide*.

Instead of LCAS, the FC_MR-4 (enhanced mode), CE-1000-4 card, and ML-Series cards support software LCAS (SW-LCAS). SW-LCAS is a limited form of LCAS that allows the VCAT circuit to adapt to member failures and keep traffic flowing at a reduced bandwidth. SW-LCAS uses legacy SONET failure indicators like AIS-P and remote defect indication, path (RDI-P) to detect member failure. SW-LCAS removes the failed member from the VCAT circuit, leaving the remaining members to carry the traffic. When the failure clears, the member circuit is automatically added back into the VCAT

circuit. For ML-Series cards, SW-LCAS allows circuit pairing over two-fiber BLSRs. With circuit pairing, a VCAT circuit is set up between two ML-Series cards: one is a protected circuit (line protection) and the other is a PCA circuit. For four-fiber BLSRs, member protection cannot be mixed. You select SW-LCAS during VCAT circuit creation. The FC_MR-4 (line rate mode) does not support SW-LCAS.

In addition, you can create non-LCAS VCAT circuits, which do not use LCAS or SW-LCAS. While LCAS and SW-LCAS member cross-connects can be in different service states, all In Group non-LCAS members must have cross-connects in the same service state. A non-LCAS circuit can mix Out of Group and In Group members, as long as the In Group members are in the same service state. Non-LCAS members do not support the OOS-MA,OOG service state; to put a non-LCAS member in the Out of Group VCAT state, use the OOS-MA,DSBLD administrative state.

**Note**

Protection switching for LCAS, SW-LCAS, and non-LCAS VCAT circuits might exceed 60ms. Traffic loss for VT VCAT circuits is approximately two times more than an STS VCAT circuit. You can minimize traffic loss by reducing path differential delay.

11.17.4 VCAT Circuit Size

Table 11-16 lists supported VCAT circuit rates and number of members for each card.

Table 11-16 ONS 15454 Card VCAT Circuit Rates and Members

Card	Circuit Rate	Number of Members
CE-100T-8	VT1.5	1–64
	STS-1	1–3 ¹
CE-1000-4	STS-1	1–21 ¹
	STS-3	1–7
FC_MR-4 (line rate mode)	STS-1	24 (1 Gbps port) 48 (2 Gbps port)
	STS-3c	8 (1 Gbps port) 16 (2 Gbps port)
FC_MR-4 (enhanced mode)	STS-1	1–24 (1 Gbps port) 1–48 (2 Gbps port)
	STS-3c	1–8 (1 Gbps port) 1–16 (2 Gbps port)
ML-Series	STS-1, STS-3c, STS-12c	2

1. A VCAT circuit with a CE-Series card as a source or destination and an ML-Series card as a source or destination can have only two members.

Use the Members tab in the Edit Circuit window to add or delete members from a VCAT circuit. The capability to add or delete members depends on the card and whether the VCAT circuit is LCAS, SW-LCAS, or non-LCAS.

- CE-100T-8 cards—You can add or delete members to an LCAS VCAT circuit without affecting service. Before deleting a member of an LCAS VCAT circuit, Cisco recommends that you put the member in the OOS-MA,OOG service state. If you create non-LCAS VCAT circuits, adding and deleting members to the circuit is possible, but service-affecting.
- CE-1000-4 cards—You can add or delete SW-LCAS VCAT members, although it might affect service. Before deleting a member, Cisco recommends that you put the member in the OOS-MA,OOG service state. If you create non-LCAS VCAT circuits, adding and deleting members to the circuit is possible, but service-affecting.
- FC_MR-4 (enhanced mode) card—You can add or delete SW-LCAS VCAT members, although it might affect service. Before deleting a member, Cisco recommends that you put the member in the OOS-MA,OOG service state. You cannot add or delete members from non-LCAS VCAT circuits on FC_MR-4 cards.
- FC_MR-4 (line mode) card—All VCAT circuits using FC_MR-4 (line mode) cards have a fixed number of members; you cannot add or delete members.
- ML-Series cards—All VCAT circuits using ML-Series cards have a fixed number of members; you cannot add or delete members.

Table 11-17 summarizes the VCAT capabilities for each card.

Table 11-17 ONS 15454 VCAT Card Capabilities

Card	Mode	Add a Member	Delete a Member	Support OOS-MA,OOG
CE-100T-8	LCAS	Yes ¹	Yes ¹	Yes
	SW-LCAS	No	No	No
	Non-LCAS	Yes ²	Yes ²	No
CE-1000-4	LCAS	No	No	No
	SW-LCAS	Yes	Yes	Yes
	Non-LCAS	Yes ²	Yes ²	No
FC_MR-4 (enhanced mode)	SW-LCAS	Yes	Yes	Yes
	Non-LCAS	No	No	No
FC_MR-4 (line mode)	Non-LCAS	No	No	No
ML-Series	SW-LCAS	No	No	No
	Non-LCAS	No	No	No

1. When adding or deleting a member from an LCAS VCAT circuit, Cisco recommends that you first put the member in the OOS-MA,OOG service state to avoid service disruptions.
2. For CE-Series cards, you can add or delete members after creating a VCAT circuit with no protection. During the time it takes to add or delete members (from seconds to minutes), the entire VCAT circuit will be unable to carry traffic.

11.18 Bridge and Roll

The CTC Bridge and Roll wizard reroutes live traffic without interrupting service. The bridge process takes traffic from a designated “roll from” facility and establishes a cross-connect to the designated “roll to” facility. When the bridged signal at the receiving end point is verified, the roll process creates a new cross-connect to receive the new signal. When the roll completes, the original cross-connects are

released. You can use the bridge and roll feature for maintenance functions such as card or facility replacement, or for load balancing. You can perform a bridge and roll on the following ONS platforms: ONS 15454, ONS 15454 SDH, ONS 15600, ONS 15327, and ONS 15310-CL.

11.18.1 Rolls Window

The Rolls window lists information about a rolled circuit before the roll process is complete. You can access the Rolls window by clicking the Circuits > Rolls tabs in either network or node view. [Figure 11-16](#) shows the Rolls window.

Figure 11-16 Rolls Window

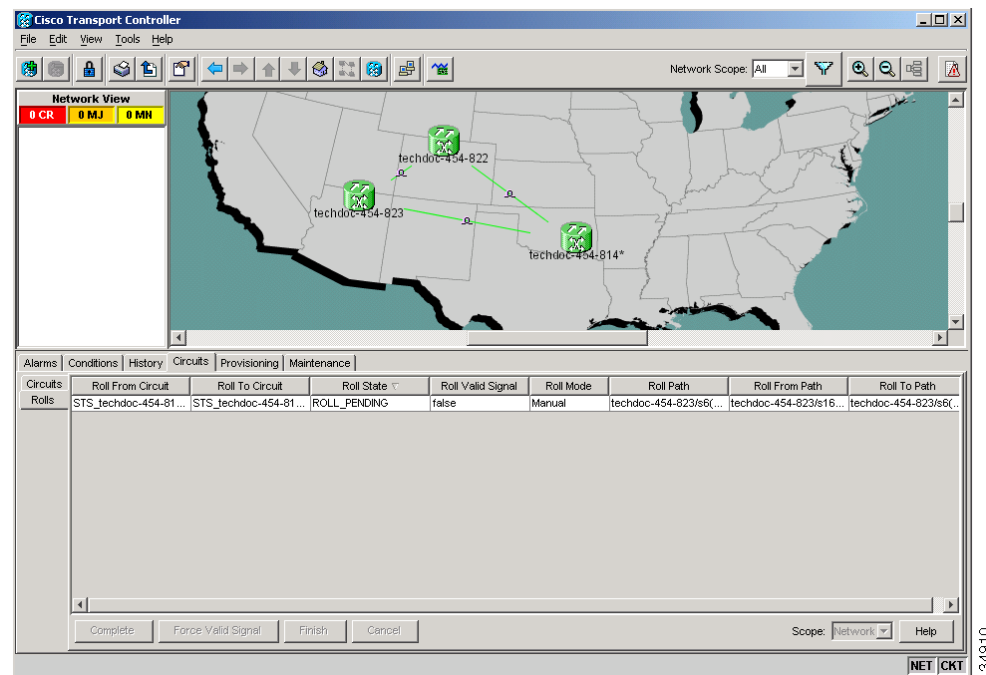

The Rolls window information includes:

- Roll From Circuit—The circuit that has connections that will no longer be used when the roll process is complete.
- Roll To Circuit—The circuit that will carry the traffic after the roll process is complete. The Roll To Circuit is the same as the Roll From Circuit if a single circuit is involved in a roll.
- Roll State—The roll status; see the “[11.18.2 Roll Status](#)” section on page 11-38.
- Roll Valid Signal—If the Roll Valid Signal status is true, a valid signal was found on the new port. If the Roll Valid Signal status is false, a valid signal was not found. It is not possible to get a Roll Valid Signal status of true for a one-way destination roll.
- Roll Mode—The mode indicates whether the roll is automatic or manual.



Note CTC implements a roll mode at the circuit level. TL1 implements a roll mode at the cross-connect level. If a single roll is performed, CTC and TL1 behave the same. If a dual roll is performed, the roll mode specified in CTC might be different than the roll mode retrieved in TL1. For example, if you select Automatic, CTC coordinates the two rolls to minimize possible traffic hits by using the Manual mode behind the scenes. When both rolls have a good signal, CTC signals the nodes to complete the roll.

- Automatic—When a valid signal is received on the new path, CTC completes the roll on the node automatically. One-way source rolls are always automatic.
- Manual—You must complete a manual roll after a valid signal is received. One-way destination rolls are always manual.
- Roll Path—The fixed point of the roll object.
- Roll From Circuit—The circuit that has connections that will no longer be used when the process is complete.
- Roll From Path— The old path that is being rerouted.
- Roll To Path—The new path where the Roll From Path is rerouted.
- Complete—Completes a manual roll after a valid signal is received. You can do this when a manual roll is in a ROLL_PENDING status and you have not yet completed the roll or have not cancelled its sibling roll.
- Force Valid Signal—Forces a roll onto the Roll To Circuit destination without a valid signal.



Note If you choose Force Valid Signal, traffic on the circuit that is involved in the roll will be dropped when the roll is completed.

- Finish—Completes the circuit processing of both manual and automatic rolls and changes the circuit status from ROLL_PENDING to DISCOVERED. After a roll, the Finish button also removes any cross-connects that are no longer used from the Roll From Circuit field.
- Cancel—Cancels the roll process.



Note When the roll mode is Manual, cancelling a roll is only allowed before you click the Complete button. When the roll mode is Auto, cancelling a roll is only allowed before a good signal is detected by the node or before clicking the Force Valid Signal button.

11.18.2 Roll Status

Table 11-18 lists the roll statuses.

Table 11-18 Roll Statuses

State	Description
ROLL_PENDING	Roll is awaiting completion or cancellation.
ROLL_COMPLETED	Roll is complete. Click the Finish button.
ROLL_CANCELLED	Roll has been canceled.

Table 11-18 Roll Statuses

State	Description
TL1_ROLL	A TL1 roll was initiated. Note If a roll is created using TL1, a CTC user cannot complete or cancel the roll. Also, if a roll is created using CTC, a TL1 user cannot complete or cancel the roll. You must use the same interface to complete or change a roll.
INCOMPLETE	This state appears when the underlying circuit becomes incomplete. To correct this state, you must fix the underlying circuit problem before the roll state will change. For example, a circuit traveling on Nodes A, B, and C can become INCOMPLETE if Node B is rebooted. The cross-connect information is lost on Node B during a reboot. The Roll State on Nodes A and C will change to INCOMPLETE.

**Note**

You can only reroute circuits in the DISCOVERED status. You cannot reroute circuits that are in the ROLL_PENDING status.

11.18.3 Single and Dual Rolls

Circuits have an additional layer of roll types: single and dual. A single roll on a circuit is a roll on one of its cross-connects. Use a single roll to:

- Change either the source or destination of a selected circuit (Figure 11-17 and Figure 11-18, respectively).
- Roll a segment of the circuit onto another chosen circuit (Figure 11-19). This roll also results in a new destination or a new source.

In Figure 11-17, you can select any available STS on Node 1 for a new source.

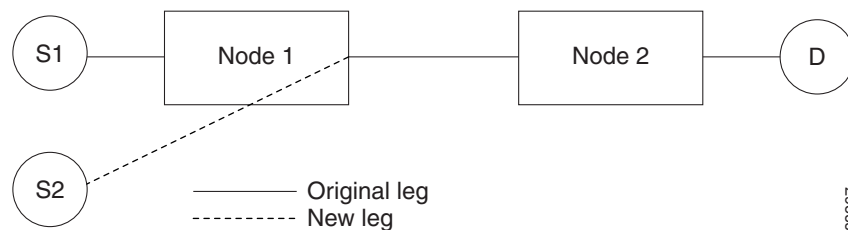
Figure 11-17 Single Source Roll

In Figure 11-18, you can select any available STS on Node 2 for a new destination.

Figure 11-18 Single Destination Roll

Figure 11-19 shows one circuit rolling onto another circuit at the destination. The new circuit has cross-connects on Node 1, Node 3, and Node 4. CTC deletes the cross-connect on Node 2 after the roll.

Figure 11-19 Single Roll from One Circuit to Another Circuit (Destination Changes)

Figure 11-20 shows one circuit rolling onto another circuit at the source.

Figure 11-20 Single Roll from One Circuit to Another Circuit (Source Changes)**Note**

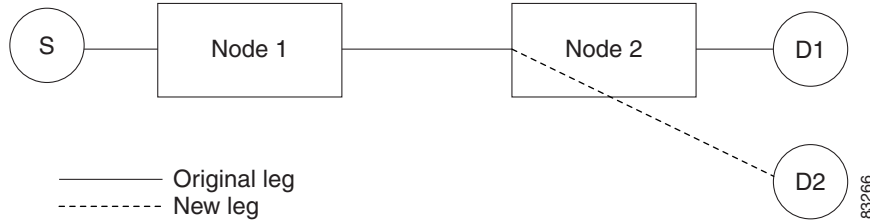
Create a Roll To Circuit before rolling a circuit with the source on Node 3 and the destination on Node 4.

A dual roll involves two cross-connects. It allows you to reroute intermediate segments of a circuit, but keep the original source and destination. If the new segments require new cross-connects, use the Bridge and Roll wizard or create a new circuit and then perform a roll.

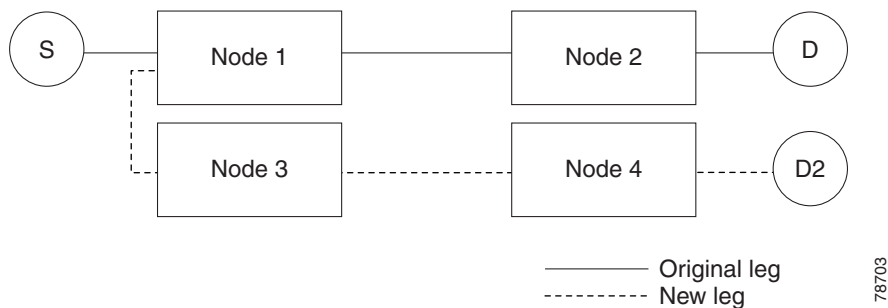
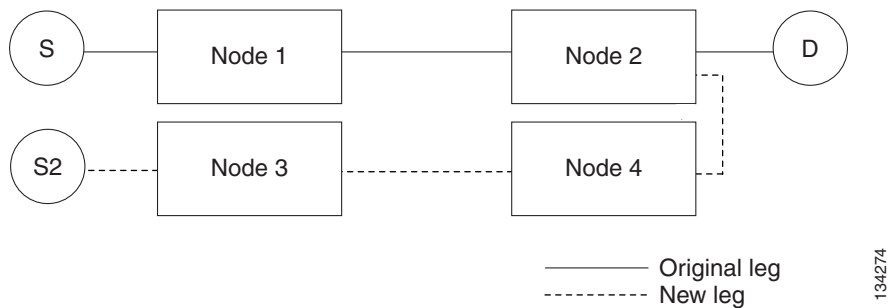
Dual rolls have several constraints:

- You must complete or cancel both cross-connects rolled in a dual roll. You cannot complete one roll and cancel the other roll.
- When a Roll To circuit is involved in the dual roll, the first roll must roll onto the source of the Roll To circuit and the second roll must roll onto the destination of the Roll To circuit.

Figure 11-21 illustrates a dual roll on the same circuit.

Figure 11-21 Dual Roll to Reroute a Link

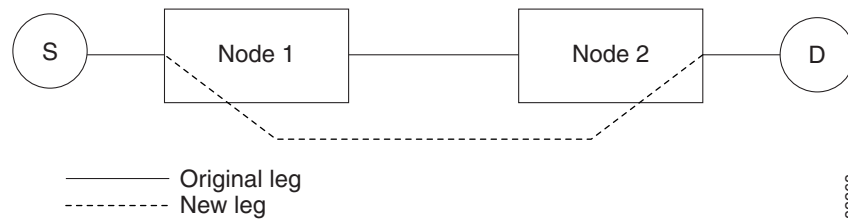
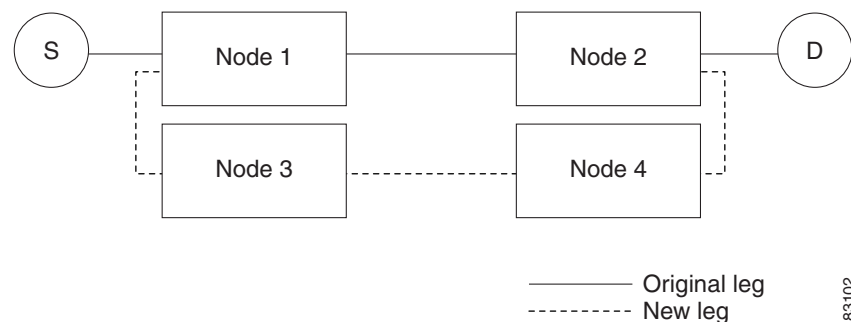

Figure 11-22 illustrates a dual roll involving two circuits.

Figure 11-22 Dual Roll to Reroute to a Different Node



Note

If a new segment is created on Nodes 3 and 4 using the Bridge and Roll wizard, the created circuit has the same name as the original circuit with the suffix `_ROLL**`. The circuit source is on Node 3 and the circuit destination is on Node 4.

11.18.4 Two Circuit Bridge and Roll

When using the bridge and roll feature to reroute traffic using two circuits, the following constraints apply:

- DCC must be enabled on the circuits involved in a roll before roll creation.
- A maximum of two rolls can exist between any two circuits.
- If two rolls are involved between two circuits, both rolls must be on the original circuit. The second circuit should not carry live traffic. The two rolls loop from the second circuit back to the original circuit. The roll mode of the two rolls must be identical (either automatic or manual).
- If a single roll exists on a circuit, you must roll the connection onto the source or the destination of the second circuit and not an intermediate node in the circuit.

11.18.5 Protected Circuits

CTC allows you to roll the working or protect path regardless of which path is active. You can upgrade an unprotected circuit to a fully protected circuit or downgrade a fully protected circuit to an unprotected circuit with the exception of a path protection circuit. When using bridge and roll on path protection circuits, you can roll the source or destination or both path selectors in a dual roll. However, you cannot roll a single path selector.

11.19 Merged Circuits

A circuit merge combines a single selected circuit with one or more circuits. You can merge VT tunnels, VAP circuits, VCAT members, CTC-created circuits, and TL1-created circuits. To merge circuits, you choose a circuit in the CTC Circuits window and the circuits that you want to merge with the chosen (master) circuit on the Merge tab in the Edit Circuits window. The Merge tab shows only the circuits that are available for merging with the master circuit:

- Circuit cross-connects must create a single, contiguous path.
- Circuits types must be a compatible. For example, you can combine an STS circuit with a VAP circuit to create a longer VAP circuit, but you cannot combine a VT circuit with an STS circuit.
- Circuit directions must be compatible. You can merge a one-way and a two-way circuit, but not two one-way circuits in opposing directions.
- Circuit sizes must be identical.
- VLAN assignments must be identical.
- Circuit end points must send or receive the same framing format.
- The merged circuits must become a DISCOVERED circuit.

If all connections from the master circuit and all connections from the merged circuits align to form one complete circuit, the merge is successful. If all connections from the master circuit and some, but not all, connections from the other circuits align to form a single complete circuit, CTC notifies you and gives you the chance to cancel the merge process. If you choose to continue, the aligned connections merge successfully into the master circuit, and the unaligned connections remain in the original circuits. All connections in the completed master circuit use the original master circuit name.

All connections from the master circuit and at least one connection from the other selected circuits must be used in the resulting circuit for the merge to succeed. If a merge fails, the master circuit and all other circuits remain unchanged. When the circuit merge completes successfully, the resulting circuit retains the name of the master circuit.

You can also merge orderwire and user data channel (UDC) overhead circuits, which use the overhead bytes instead of frame payload to transfer data. To merge overhead circuits, you choose the overhead circuits on the network view Provisioning > Overhead Circuits window. You can only merge orderwire and UDC circuits.

11.20 Reconfigured Circuits

You can reconfigure multiple circuits, which is typically necessary when a large number of circuits are in the PARTIAL status. When reconfiguring multiple circuits, the selected circuits can be any combination of DISCOVERED, PARTIAL, DISCOVERED_TL1, or PARTIAL_TL1 circuits. You can reconfigure tunnels, VAP circuits, VLAN-assigned circuits, VCAT circuits, CTC-created circuits, and TL1-created circuits. The Reconfigure command maintains the names of the original cross-connects.

Use the CTC Tools > Circuits > Reconfigure Circuits menu item to reconfigure selected circuits. During reconfiguration, CTC reassembles all connections of the selected circuits and VCAT members into circuits based on path size, direction, and alignment. Some circuits might merge and others might split into multiple circuits. If the resulting circuit is a valid circuit, it appears as a DISCOVERED circuit. Otherwise, the circuit appears as a PARTIAL or PARTIAL_TL1 circuit.

**Note**

If CTC cannot reconfigure all members in a VCAT circuit, the reconfigure operation fails for the entire VCAT circuit and it remains in the PARTIAL or PARTIAL_TL1 status. If CTC does reconfigure all members in a VCAT circuit, the VCAT circuit may still remain in the PARTIAL or PARTIAL_TL1 status. This occurs if the ports defined in the VCAT termination do not match the source/drop ports of the member circuits or if one or two VCAT terminations are missing.

**Note**

PARTIAL tunnel and PARTIAL VLAN-capable circuits do not split into multiple circuits during reconfiguration.

11.21 VLAN Management

In Software Release 4.6 and later, VLANs are populated within topologies to limit broadcasts to each topology rather than to the entire network. Using the Manage VLANs command in the Tools menu, you can view a list of topology hosts and provisioned VLANs. You create VLANs during circuit creation or with the Manage VLANs command. When creating a VLAN, you must identify the topology host (node) where the VLAN will be provisioned. The Manage VLANs command also allows you to delete existing VLANs.

11.22 Server Trails

A server trail is a non-DCC link across a third-party network that connects two CTC network domains. A server trail allows circuit provisioning when no DCC is available. You can create server trails between any two optical or DS-3 ports. The end ports on a server trail can be different types (for example, an OC-3 port can connect to an OC-12 port). Server trails are not allowed on DCC-enabled ports.

**Note**

A physical link must exist, end to end, and be in tact to route circuits across a server trail.

The server trail link is bidirectional and can be VT1.5, VT2, STS1, STS-3c, STS-6c, STS-12c, STS-48c, or STS-192c; you cannot upgrade an existing server trail to another size. A server trail link can be one of the following protection types: Preemptible, Unprotected, and Fully Protected. The server trail protection type determines the protection type for any circuits that traverse it. PCA circuits will use server trails with the Preemptible attribute.

When creating circuits or VCATs, you can choose a server trail link during manual circuit routing. CTC may also route circuits over server trail links during automatic routing. VCAT common-fiber automatic routing is not supported.



CHAPTER 12

SONET Topologies and Upgrades



Note

The terms "Unidirectional Path Switched Ring" and "UPSR" may appear in Cisco literature. These terms do not refer to using Cisco ONS 15xxx products in a unidirectional path switched ring configuration. Rather, these terms, as well as "Path Protected Mesh Network" and "PPMN," refer generally to Cisco's path protection feature, which may be used in any topological network configuration. Cisco does not recommend using its path protection feature in any particular topological network configuration.

This chapter explains Cisco ONS 15454 SONET topologies and upgrades. To provision topologies, refer to the *Cisco ONS 15454 Procedure Guide*.

Chapter topics include:

- [12.1 SONET Rings and TCC2/TCC2P Cards, page 12-1](#)
- [12.2 Bidirectional Line Switched Rings, page 12-3](#)
- [12.3 Comparison of the Protection Schemes, page 12-14](#)
- [12.4 Linear ADM Configurations, page 12-15](#)
- [12.5 Path-Protected Mesh Networks, page 12-15](#)
- [12.6 Four-Shelf Node Configurations, page 12-17](#)
- [12.7 OC-N Speed Upgrades, page 12-18](#)
- [12.8 In-Service Topology Upgrades, page 12-21](#)
- [12.3 Comparison of the Protection Schemes, page 12-14](#)

12.1 SONET Rings and TCC2/TCC2P Cards

[Table 12-1](#) shows the SONET rings that can be created on each ONS 15454 node using redundant TCC2/TCC2P cards.

Table 12-1 ONS 15454 Rings with Redundant TCC2/TCC2P Cards

Ring Type	Maximum Rings per Node
BLSRs	5
2-Fiber BLSR	5
4-Fiber BLSR	1
Path Protection with SDCC	34 ^{1,2}

Table 12-1 *ONS 15454 Rings with Redundant TCC2/TCC2P Cards (continued)*

Ring Type	Maximum Rings per Node
Path Protection with LDCC	14 ^{3,4}

Table 12-1 ONS 15454 Rings with Redundant TCC2/TCC2P Cards (continued)

Ring Type	Maximum Rings per Node
Path Protection with LDCC and SDCC	26 ⁵

1. Total SDCC usage must be equal to or less than 84 SDCCs.
2. See the “12.4 Linear ADM Configurations” section on page 12-15.
3. Total LDCC usage must be equal to or less than 28 LDCCs.
4. See the “12.4 Linear ADM Configurations” section on page 12-15.
5. Total LDCC and SDCC usage must be equal to or less than 84. When LDCC is provisioned, an SDCC termination is allowed on the same port, but is not recommended. Using SDCC and LDCC on the same port is only needed during a software upgrade if the other end of the link does not support LDCC. You can provision SDCCs and LDCCs on different ports in the same node.

12.2 Bidirectional Line Switched Rings

The ONS 15454 can support five concurrent bidirectional line switch rings (BLSRs) in one of the following configurations:

- Five two-fiber BLSRs
- Four two-fiber and one four-fiber BLSR

Each BLSR can have up to 32 ONS 15454s. Because the working and protect bandwidths must be equal, you can create only OC-12 (two-fiber only), OC-48, or OC-192 BLSRs.



Note

For best performance, BLSRs should have one LAN connection for every ten nodes in the BLSR.

12.2.1 Two-Fiber BLSRs

In two-fiber BLSRs, each fiber is divided into working and protect bandwidths. For example, in an OC-48 BLSR (Figure 12-1), STSs 1 to 24 carry the working traffic, and STSs 25 to 48 are reserved for protection. Working traffic (STSs 1 to 24) travels in one direction on one fiber and in the opposite direction on the second fiber. The Cisco Transport Controller (CTC) circuit routing routines calculate the shortest path for circuits based on many factors, including user requirements, traffic patterns, and distance. For example, in Figure 12-1, circuits going from Node 0 to Node 1 typically travel on Fiber 1, unless that fiber is full, in which case circuits are routed on Fiber 2 through Node 3 and Node 2. Traffic from Node 0 to Node 2 (or Node 1 to Node 3) can be routed on either fiber, depending on circuit provisioning requirements and traffic loads.

Figure 12-1 Four-Node, Two-Fiber BLSR

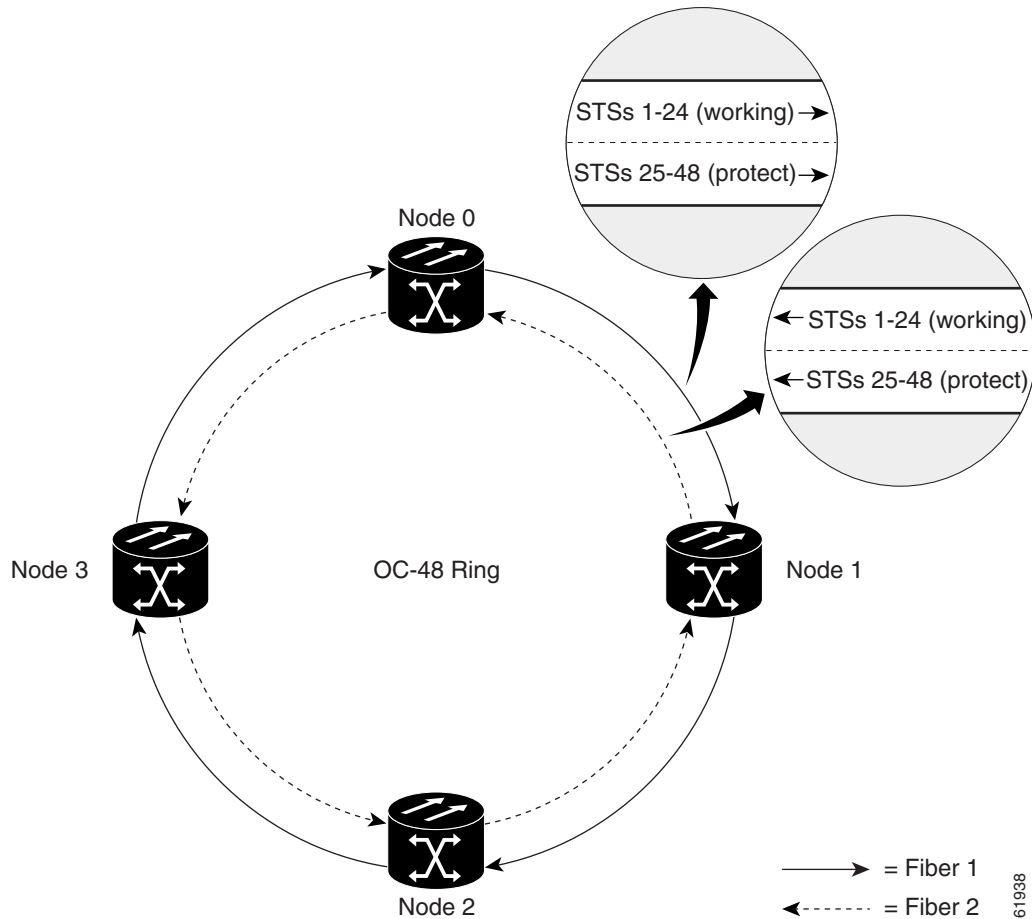

The SONET K1, K2, and K3 bytes carry the information that governs BLSR protection switches. Each BLSR node monitors the K bytes to determine when to switch the SONET signal to an alternate physical path. The K bytes communicate failure conditions and actions taken between nodes in the ring.

If a break occurs on one fiber, working traffic targeted for a node beyond the break switches to the protect bandwidth on the second fiber. The traffic travels in a reverse direction on the protect bandwidth until it reaches its destination node. At that point, traffic is switched back to the working bandwidth.

Figure 12-2 shows a traffic pattern sample on a four-node, two-fiber BLSR.

Figure 12-2 Four-Node, Two-Fiber BLSR Traffic Pattern Sample

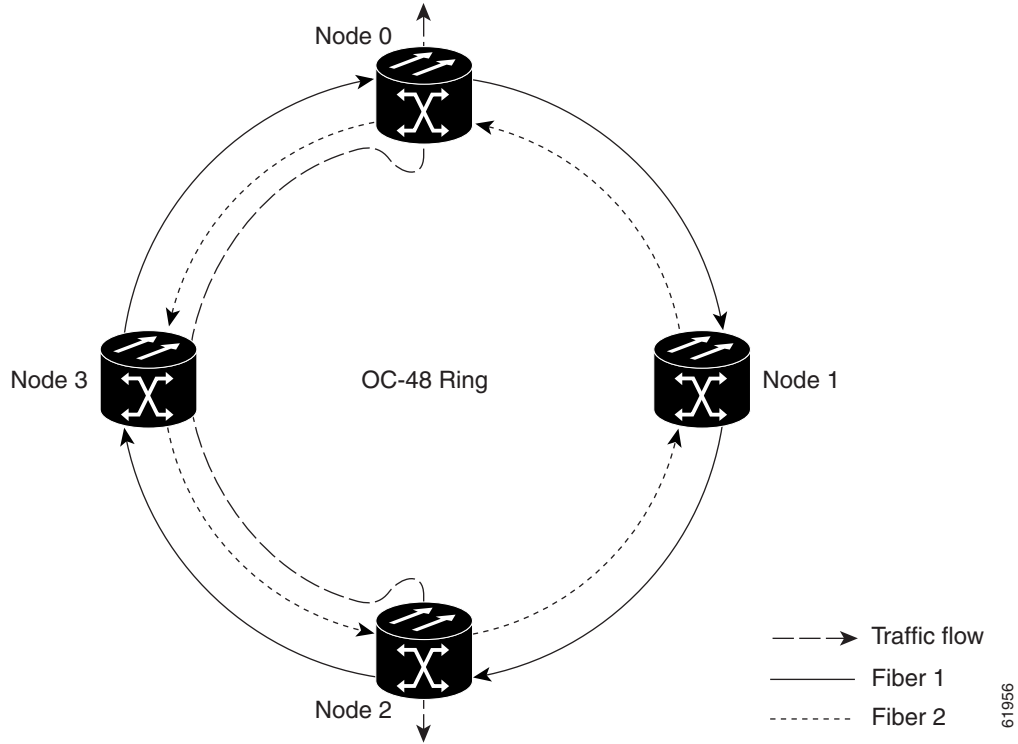
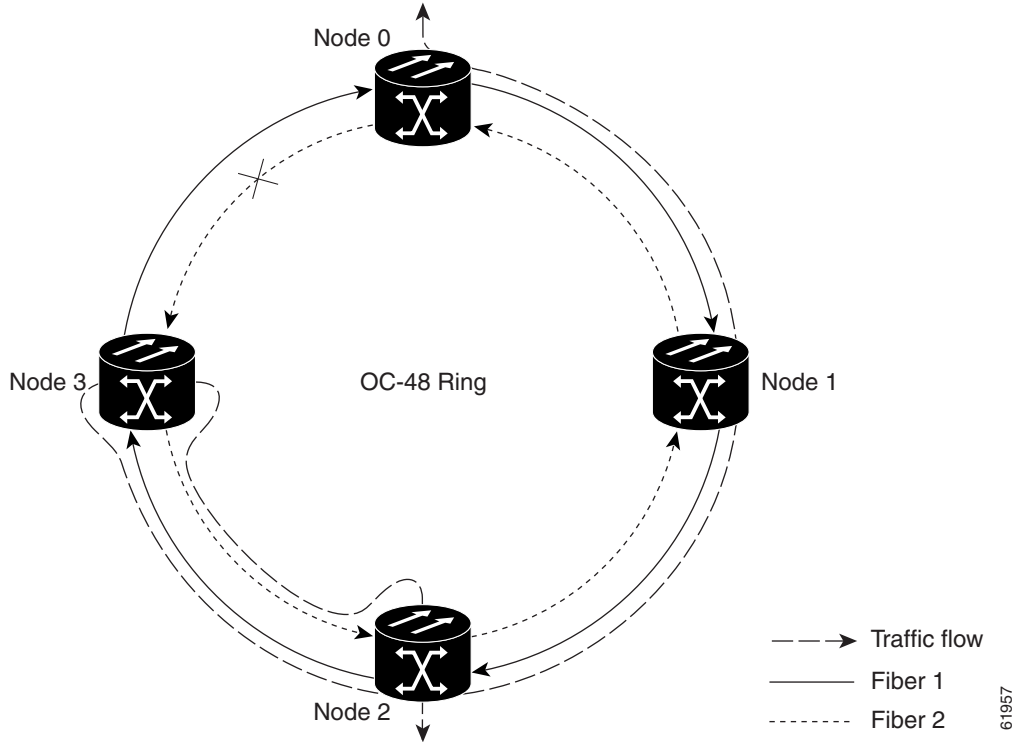

Figure 12-3 shows how traffic is rerouted following a line break between Node 0 and Node 3.

- All circuits originating on Node 0 that carried traffic to Node 2 on Fiber 2 are switched to the protect bandwidth of Fiber 1. For example, a circuit carrying traffic on STS-1 on Fiber 2 is switched to STS-25 on Fiber 1. A circuit carried on STS-2 on Fiber 2 is switched to STS-26 on Fiber 1. Fiber 1 carries the circuit to Node 3 (the original routing destination). Node 3 switches the circuit back to STS-1 on Fiber 2 where it is routed to Node 2 on STS-1.
- Circuits originating on Node 2 that normally carried traffic to Node 0 on Fiber 1 are switched to the protect bandwidth of Fiber 2 at Node 3. For example, a circuit carrying traffic on STS-2 on Fiber 1 is switched to STS-26 on Fiber 2. Fiber 2 carries the circuit to Node 0 where the circuit is switched back to STS-2 on Fiber 1 and then dropped to its destination.

Figure 12-3 Four-Node, Two-Fiber BLSR Traffic Pattern Following Line Break



12.2.2 Four-Fiber BLSRs

Four-fiber BLSRs double the bandwidth of two-fiber BLSRs. Because they allow span switching as well as ring switching, four-fiber BLSRs increase the reliability and flexibility of traffic protection. Two fibers are allocated for working traffic and two fibers for protection, as shown in [Figure 12-4](#). To implement a four-fiber BLSR, you must install four OC-48, OC-48 AS, or OC-192 cards at each BLSR node.

Figure 12-4 Four-Node, Four-Fiber BLSR

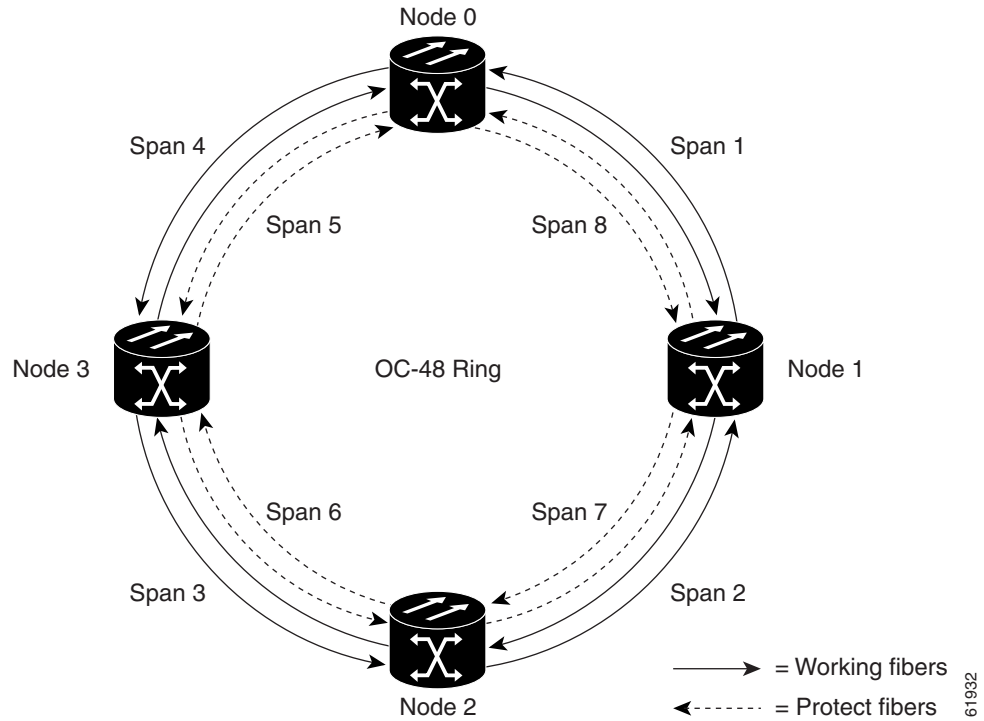

Four-fiber BLSRs provide span and ring switching:

- Span switching (Figure 12-5 on page 12-8) occurs when a working span fails. Traffic switches to the protect fibers between the nodes (Node 0 and Node 1 in the example in Figure 12-5) and then returns to the working fibers. Multiple span switches can occur at the same time.

Figure 12-5 Four-Fiber BLSR Span Switch

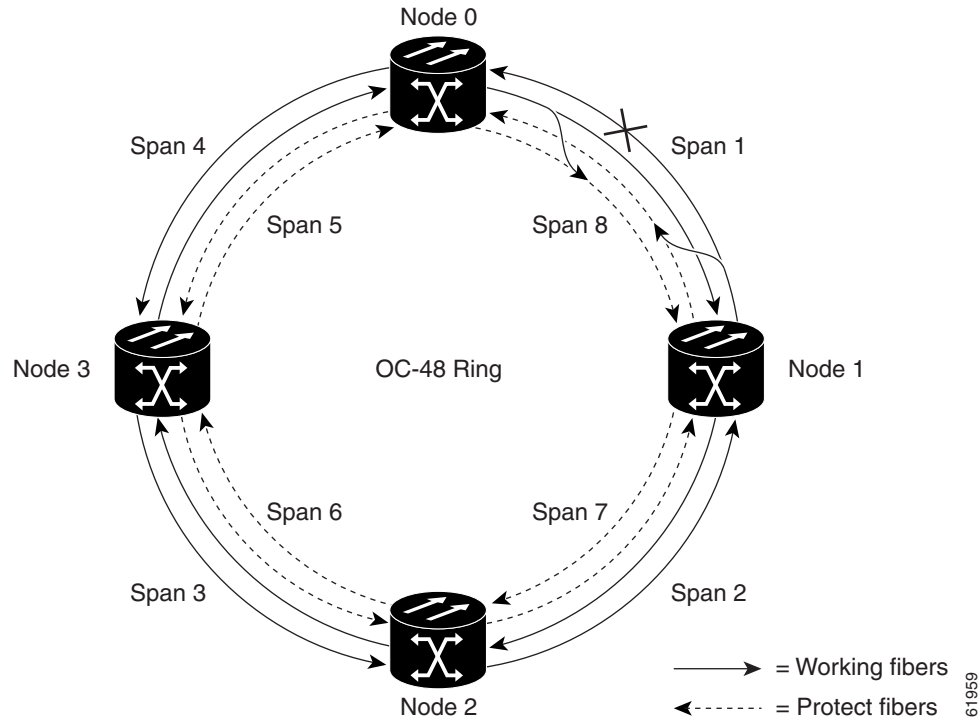

- Ring switching (Figure 12-6) occurs when a span switch cannot recover traffic, such as when both the working and protect fibers fail on the same span. In a ring switch, traffic is routed to the protect fibers throughout the full ring.

Figure 12-6 Four-Fiber BLSR Ring Switch

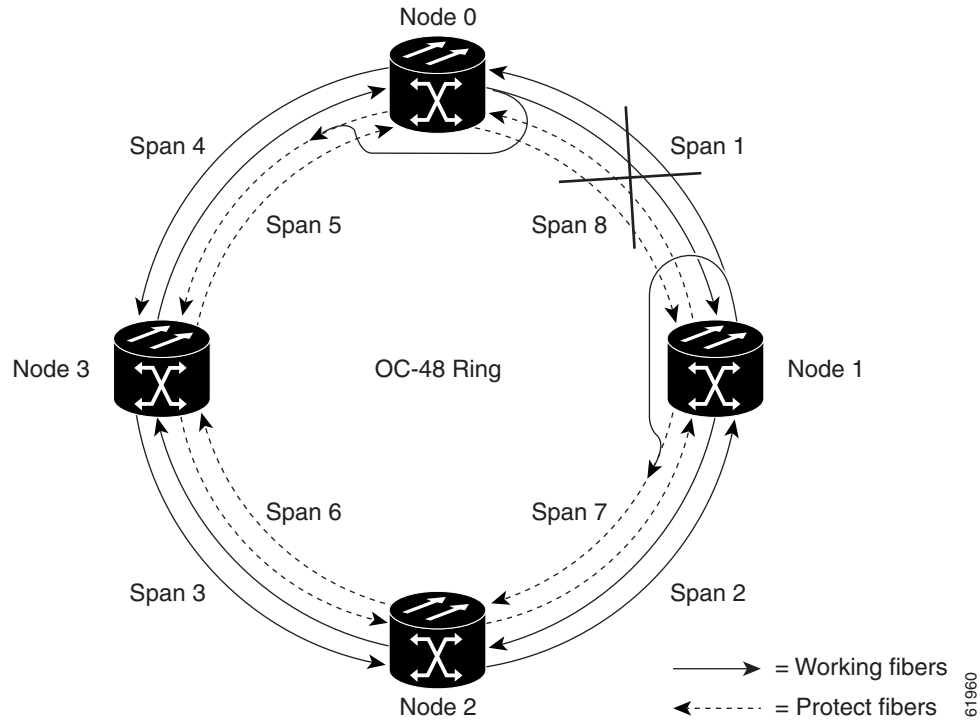

12.2.3 BLSR Bandwidth

BLSR nodes can terminate traffic coming from either side of the ring. Therefore, BLSRs are suited for distributed node-to-node traffic applications such as interoffice networks and access networks.

BLSRs allow bandwidth to be reused around the ring and can carry more traffic than a network with traffic flowing through one central hub. BLSRs can also carry more traffic than a path protection operating at the same OC-N rate. Table 12-2 shows the bidirectional bandwidth capacities of two-fiber BLSRs. The capacity is the OC-N rate divided by two, multiplied by the number of nodes in the ring minus the number of pass-through STS-1 circuits.

Table 12-2 Two-Fiber BLSR Capacity

OC Rate	Working Bandwidth	Protection Bandwidth	Ring Capacity
OC-12	STS1-6	STS 7-12	$6 \times N^1 - PT^2$
OC-48	STS 1-24	STS 25-48	$24 \times N - PT$
OC-192	STS 1-96	STS 97-192	$96 \times N - PT$

1. N equals the number of ONS 15454 nodes configured as BLSR nodes.
2. PT equals the number of STS-1 circuits passed through ONS 15454 nodes in the ring (capacity can vary depending on the traffic pattern).

Table 12-3 shows the bidirectional bandwidth capacities of four-fiber BLSRs.

Table 12-3 Four-Fiber BLSR Capacity

OC Rate	Working Bandwidth	Protection Bandwidth	Ring Capacity
OC-48	STS 1-48 (Fiber 1)	STS 1-48 (Fiber 2)	$48 \times N^1 - PT^2$
OC-192	STS 1-192 (Fiber 1)	STS 1-192 (Fiber 2)	$192 \times N - PT$

1. N equals the number of ONS 15454 nodes configured as BLSR nodes.
2. PT equals the number of STS-1 circuits passed through ONS 15454 nodes in the ring (capacity can vary depending on the traffic pattern).

Figure 12-7 shows an example of BLSR bandwidth reuse. The same STS carries three different traffic sets simultaneously on different spans around the ring: one set from Node 3 to Node 1, another set from Node 1 to Node 2, and another set from Node 2 to Node 3.

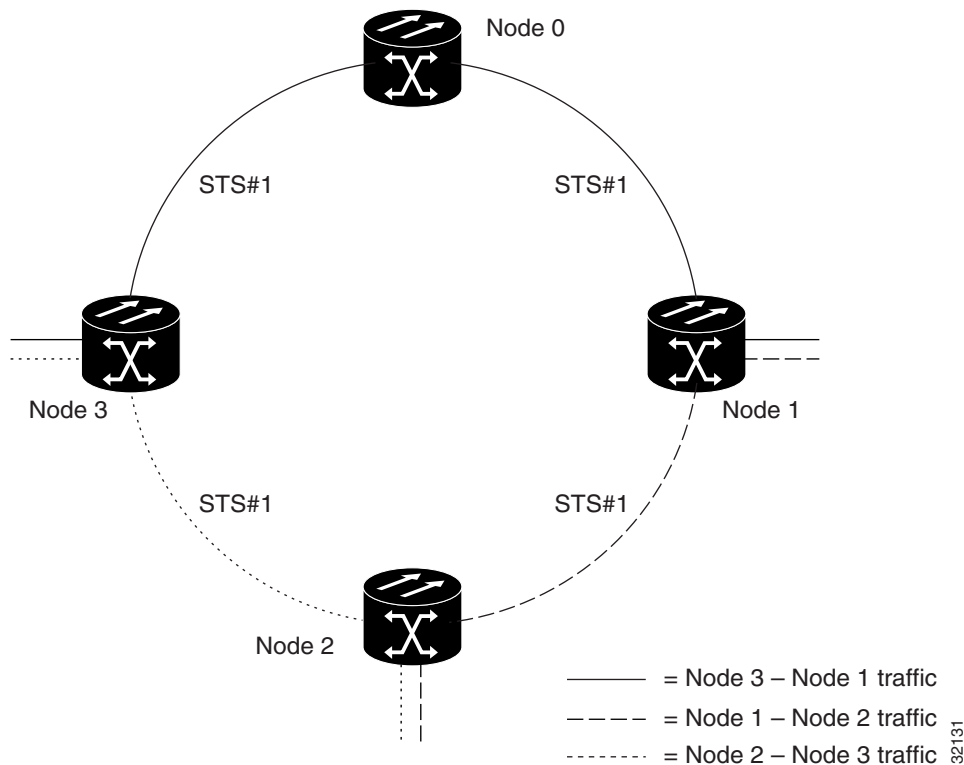
Figure 12-7 BLSR Bandwidth Reuse

12.2.4 BLSR Application Example

Figure 12-8 shows a two-fiber BLSR implementation example with five nodes. A regional long-distance network connects to other carriers at Node 0. Traffic is delivered to the service provider's major hubs.

- Carrier 1 delivers six DS-3s over two OC-3 spans to Node 0. Carrier 2 provides twelve DS-3s directly. Node 0 receives the signals and delivers them around the ring to the appropriate node.
- The ring also brings 14 DS-1s back from each remote site to Node 0. Intermediate nodes serve these shorter regional connections.

- The ONS 15454 OC-3 card supports a total of four OC-3 ports so that two additional OC-3 spans can be added at little cost.

Figure 12-8 Five-Node Two-Fiber BLSR

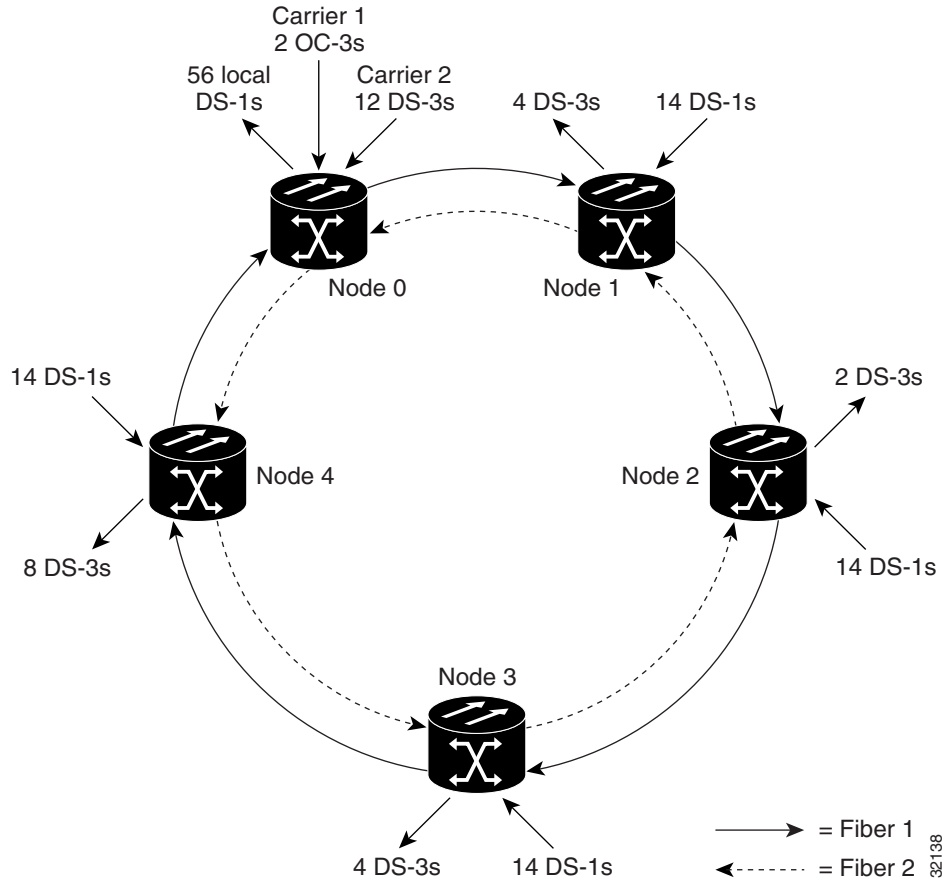

Figure 12-9 shows the shelf assembly layout for Node 0, which has one free slot.

Figure 12-9 Shelf Assembly Layout for Node 0 in Figure 12-8

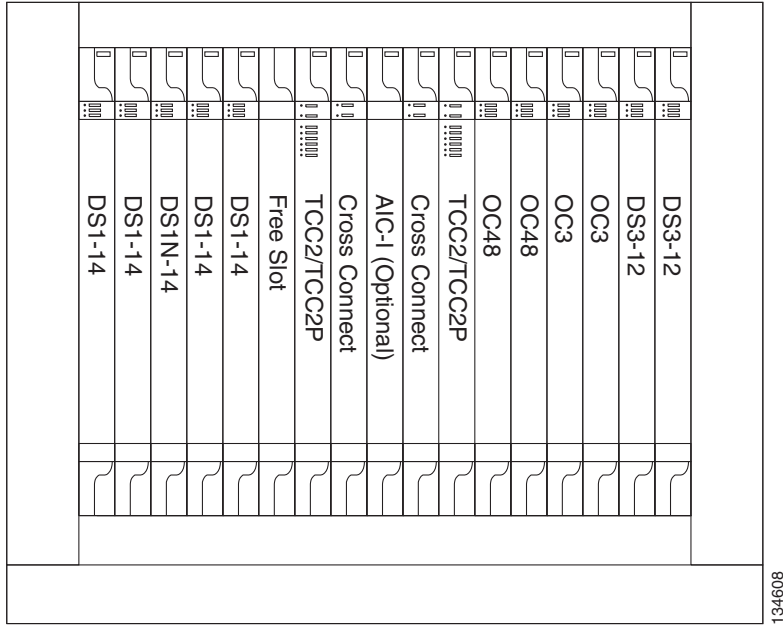
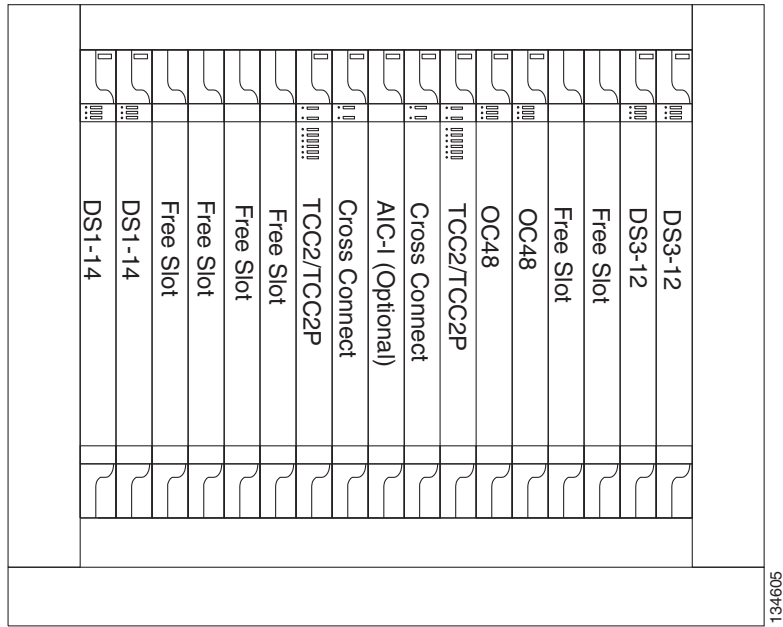

Figure 12-10 shows the shelf assembly layout for the remaining sites in the ring. In this BLSR configuration, an additional eight DS-3s at Node IDs 1 and 3 can be activated. An additional four DS-3s can be added at Node 4, and ten DS-3s can be added at Node 2. Each site has free slots for future traffic needs.

Figure 12-10 Shelf Assembly Layout for Nodes 1 to 4 in Figure 12-8



12.2.5 BLSR Fiber Connections

Plan your fiber connections and use the same plan for all BLSR nodes. For example, make the east port the farthest slot to the right and the west port the farthest slot to the left. Plug fiber connected to an east port at one node into the west port on an adjacent node. [Figure 12-11](#) shows fiber connections for a two-fiber BLSR with trunk cards in Slot 5 (west) and Slot 12 (east). Refer to the *Cisco ONS 15454 Procedure Guide* for fiber connection procedures.



Note Always plug the transmit (Tx) connector of an OC-N card at one node into the receive (Rx) connector of an OC-N card at the adjacent node. Cards display an SF LED when Tx and Rx connections are mismatched.

Figure 12-11 Connecting Fiber to a Four-Node, Two-Fiber BLSR

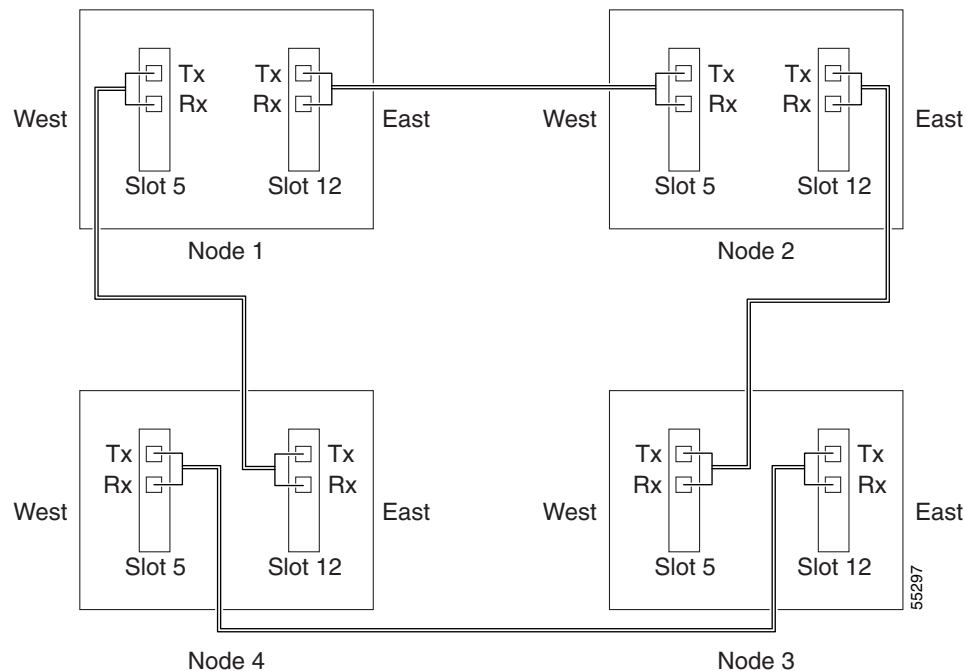

For four-fiber BLSRs, use the same east-west connection pattern for the working and protect fibers. Do not mix working and protect card connections. The BLSR does not function if working and protect cards are interconnected. [Figure 12-12](#) shows fiber connections for a four-fiber BLSR. Slot 5 (west) and Slot 12 (east) carry the working traffic. Slot 6 (west) and Slot 13 (east) carry the protect traffic.

Figure 12-12 Connecting Fiber to a Four-Node, Four-Fiber BLSR

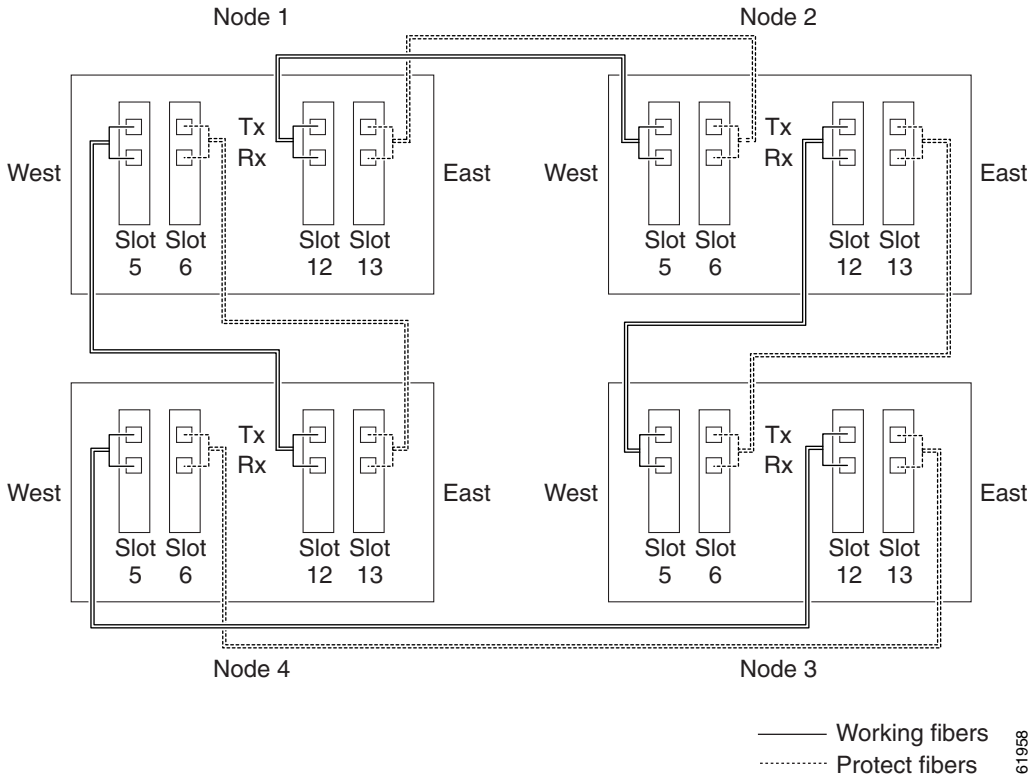

12.3 Comparison of the Protection Schemes

Table 12-4 shows a comparison of the different protection schemes using OC-48 as an example.

Table 12-4 Comparison of the Protection Schemes

Topology	Ring Capacity	Protected Bandwidth Between Any Two Nodes	Protection Channel Access	Dual Failure	Number of Cards
Path Protection	48 - PT	STS 1-48	Not supported	Not supported	2 x N
Two-Fiber BLSR	$24 \times N^1 - PT^2$	STS 1-24	STS 25-48	Not supported	2 x N
Four-Fiber BLSR	$48 \times N - PT$	STS 1-48 (Fiber 1)	STS 1-48 (Fiber 2)	Supported	4 x N
Two-Fiber BLSR DRI	$24 \times N - PT$	STS 1-24	STS 25-48	Supported	$(2 \times N) + 4$
Path Protection DRI	48 - PT	STS 1-48	Not supported	Supported	$(2 \times N) + 4$

1. N equals the number of ONS 15454 nodes configured as BLSR nodes.

- PT equals the number of STS-1 circuits passed through ONS 15454 nodes in the ring (capacity can vary depending on the traffic pattern).

12.4 Linear ADM Configurations

You can configure ONS 15454s as a line of add/drop multiplexers (ADMs) by configuring one set of OC-N cards as the working path and a second set as the protect path. Unlike rings, point-to-point ADMs (two-node configurations) and linear ADMs (three-node configurations) require that the OC-N cards at each node be in 1+1 protection to ensure that a break to the working line is automatically routed to the protect line.

Figure 12-13 shows three ONS 15454 nodes in a linear ADM configuration. Working traffic flows from Slot 5/Node 1 to Slot 5/Node 2, and from Slot 12/Node 2 to Slot 12/Node 3. You create the protect path by placing Slot 6 in 1+1 protection with Slot 5 at Nodes 1 and 2, and Slot 12 in 1+1 protection with Slot 13 at Nodes 2 and 3.

Figure 12-13 Linear (Point-to-Point) ADM Configuration

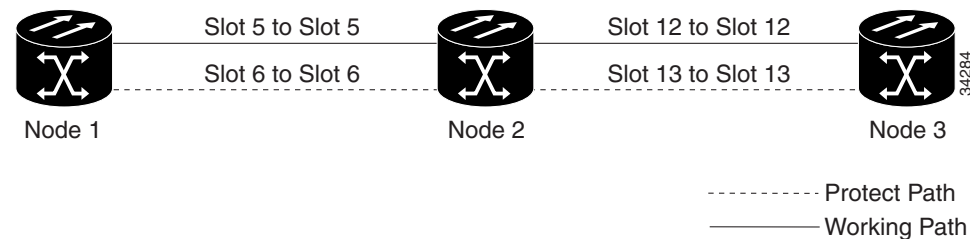

12.5 Path-Protected Mesh Networks

In addition to single BLSRs, path protection configurations, and ADMs, you can extend ONS 15454 traffic protection by creating path-protected mesh networks (PPMNs). PPMNs include multiple ONS 15454 SONET topologies and extend the protection provided by a single path protection configurations to the meshed architecture of several interconnecting rings. In a PPMN, circuits travel diverse paths through a network of single or multiple meshed rings. When you create circuits, you can have CTC automatically route circuits across the PPMN, or you can manually route them. You can also choose levels of circuit protection. For example, if you choose full protection, CTC creates an alternate route for the circuit in addition to the main route. The second route follows a unique path through the network between the source and destination and sets up a second set of cross-connections.

For example, in Figure 12-14 a circuit is created from Node 3 to Node 9. CTC determines that the shortest route between the two nodes passes through Node 8 and Node 7, shown by the dotted line, and automatically creates cross-connections at Nodes 3, 8, 7, and 9 to provide the primary circuit path.

If full protection is selected, CTC creates a second unique route between Nodes 3 and 9 which, in this example, passes through Nodes 2, 1, and 11. Cross-connections are automatically created at Nodes 3, 2, 1, 11, and 9, shown by the dashed line. If a failure occurs on the primary path, traffic switches to the second circuit path. In this example, Node 9 switches from the traffic coming in from Node 7 to the traffic coming in from Node 11 and service resumes. The switch occurs within 50 ms.

Figure 12-14 Path-Protected Mesh Network

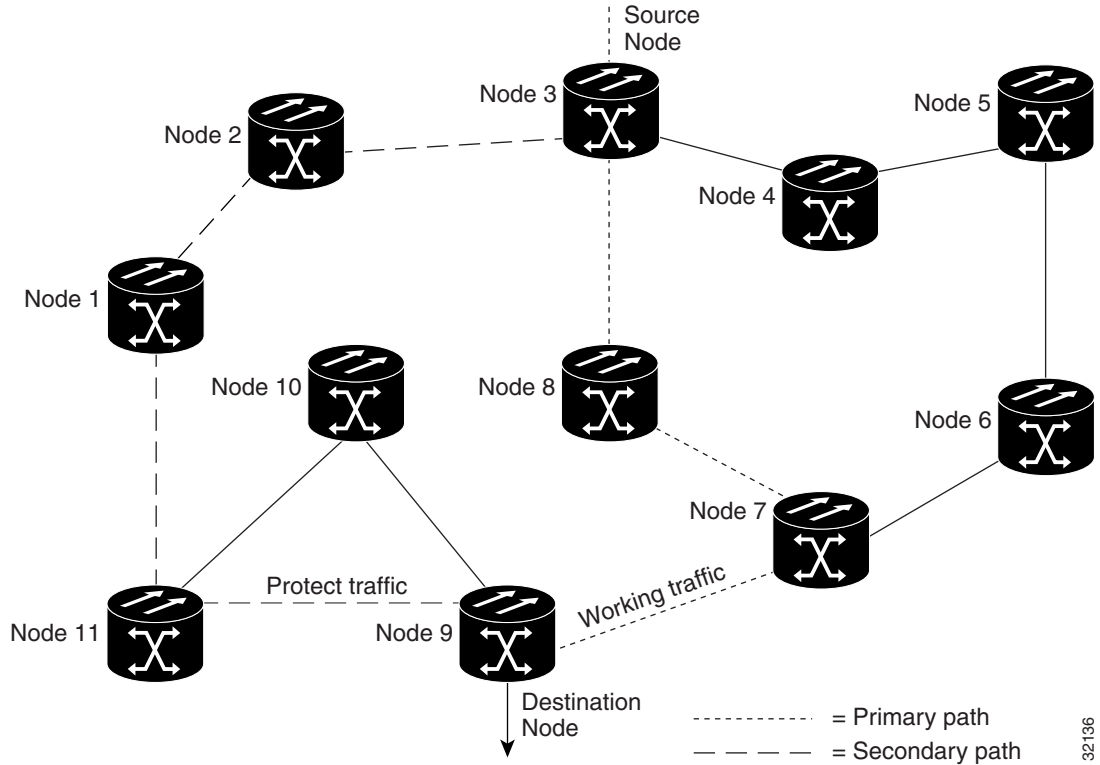

PPMN also allows spans with different SONET speeds to be mixed together in “virtual rings.” Figure 12-15 shows Nodes 1, 2, 3, and 4 in a standard OC-48 ring. Nodes 5, 6, 7, and 8 link to the backbone ring through OC-12 fiber. The “virtual ring” formed by Nodes 5, 6, 7, and 8 uses both OC-48 and OC-12 cards.

Figure 12-15 PPMN Virtual Ring

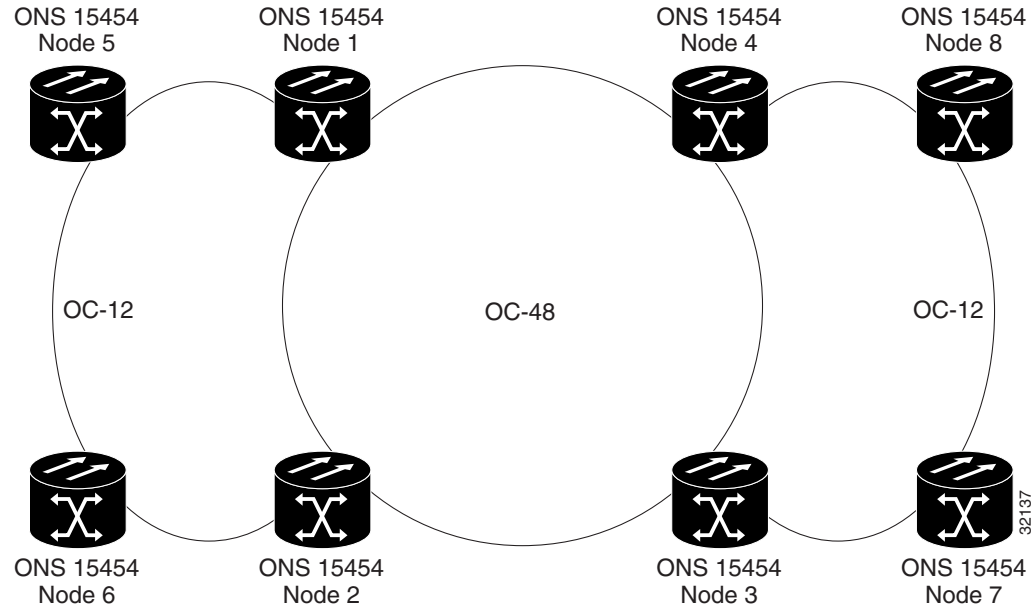

12.6 Four-Shelf Node Configurations

You can link multiple ONS 15454s using their OC-N cards (that is, create a fiber-optic bus) to accommodate more access traffic than a single ONS 15454 can support. Refer to the *Cisco ONS 15454 Procedure Guide*. For example, to drop more than 112 DS-1s or 96 DS-3s (the maximum that can be aggregated in a single node), you can link the nodes but not merge multiple nodes into a single ONS 15454. You can link nodes with OC-12 or OC-48 fiber spans as you would link any other two network nodes. The nodes can be grouped in one facility to aggregate more local traffic.

Figure 12-16 on page 12-18 shows a four-shelf node setup. Each shelf assembly is recognized as a separate node in the ONS 15454 software interface and traffic is mapped using CTC cross-connect options. In Figure 12-16, each node uses redundant fiber-optic cards. Node 1 uses redundant OC-N transport and OC-N bus (connecting) cards for a total of four cards, with eight free slots remaining. Nodes 2 and 3 each use two redundant OC-N bus cards for a total of four cards, with eight free slots remaining. Node 4 uses redundant OC-12 bus cards for a total of two cards, with ten free slots remaining. The four-shelf node example presented here is one of many ways to set up a multiple-node configuration.

Figure 12-16 Four-Shelf Node Configuration

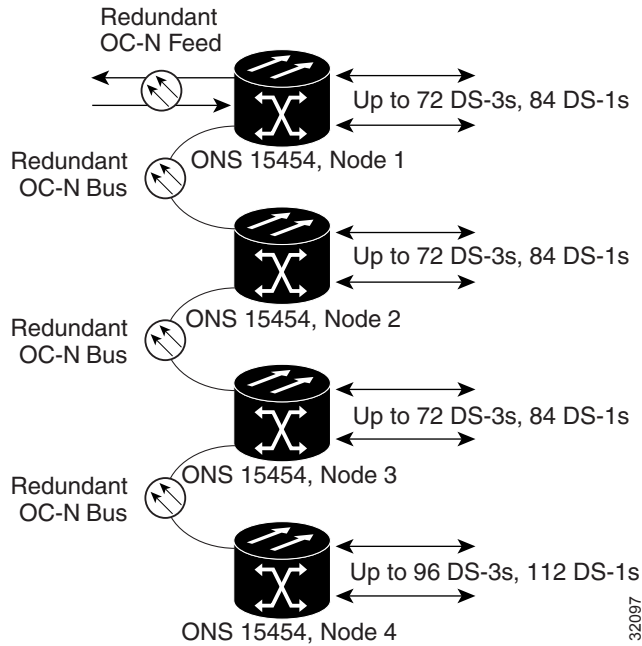

12.7 OC-N Speed Upgrades

A span is the optical fiber connection between two ONS 15454 nodes. In a span (optical speed) upgrade, the transmission rate of a span is upgraded from a lower to a higher OC-N signal but all other span configuration attributes remain unchanged. With multiple nodes, a span upgrade is a coordinated series of upgrades on all nodes in the ring or protection group. You can perform in-service span upgrades for the following ONS 15454 cards:

- Single-port OC-12 to OC-48
- Single-port OC-12 to OC-192
- Single-port OC-12 to four-port OC-12
- Single-port OC-12 to MRC-12
- OC-48 to OC-192
- OC-48 to OC192SR1/STM64IO Short Reach or OC192/STM64 Any Reach

You can also perform in-service card upgrades for the following ONS 15454 cards:

- Four-port OC-3 to eight-port OC-3
- Single-port OC-12 to four-port OC-12
- Single-port OC-12 to OC-48
- Single-port OC-12 to OC-192
- Single-port OC-12 to MRC-12
- OC-48 to MRC-12
- OC-192 to OC192-XFP

- OC-48 to OC192SR1/STM64IO Short Reach or OC192/STM64 Any Reach

Table 12-5 lists permitted upgrades for Slots 5, 6, 12, and 13 (high-speed slots).

Table 12-5 Slot 5, 6, 12, and 13 Upgrade Options

Cards	Four-port OC-3	Eight-port OC-3	One-port OC-12	Four-port OC-12	OC-48	OC-192	MRC-12
Four-port OC-3	—	Not supported	Not supported	Not supported	Not supported	Not supported	Not supported
Eight-port OC-3 ¹	Not supported	—	Not supported	Not supported	Not supported	Not supported	Not supported
One-port OC-12	Not supported	Not supported	—	Not supported	Supported	Supported	Supported
Four-port OC-12 ²	Not supported	Not supported	Not supported	—	Not supported	Not supported	Not supported
OC-48	Not supported	Not supported	Supported	Not supported	—	Supported	Supported
OC-192	Not supported	Not supported	Supported	Not supported	Supported	—	Not supported
MRC-12	Not supported	Not supported	Supported	Not supported	Supported	Not supported	—

1. The eight-port OC-3 is not supported in Slots 5, 6, 12, and 13.

2. The four-port OC-12 is not supported in Slots 5, 6, 12, and 13.

Table 12-6 lists permitted upgrades for Slots 1 through 4 and 14 through 17 (low-speed slots).

Table 12-6 Upgrade Options for Slots 1 through 4 and 14 through 17

Cards	Four-port OC-3	Eight-port OC-3	One-port OC-12	Four-port OC-12	OC-48	OC-192	MRC-12
Four-port OC-3	—	Supported	Not supported	Not supported	Not supported	—	Not supported
Eight-port OC-3	Supported	—	Not supported	Not supported	Not supported	—	Not supported
One-port OC-12	Not supported	Not supported	—	Supported	Supported	—	Supported
Four-port OC-12	Not supported	Not supported	Supported	—	Not supported	—	Not supported
OC-48	Not supported	Not supported	Supported	Not supported	—	—	Supported
OC-192 ¹	—	—	—	—	—	—	Not supported
MRC-12	Not supported	Not supported	Supported	Not supported	Supported	Not supported	—

1. The OC-192 is not supported on Slots 1 through 4 and 14 through 17.

**Note**

Replacing cards that are the same speed are not considered span upgrades. For example replacing a four-port OC-3 with an eight-port OC-3 card or replacing a single-port OC-12 with a four-port OC-12 card.

To perform a span upgrade, the higher-rate OC-N card must replace the lower-rate card in the same slot. If the upgrade is conducted on spans residing in a BLSR, all spans in the ring must be upgraded. The protection configuration of the original lower-rate OC-N card (two-fiber BLSR, four-fiber BLSR, path protection, and 1+1) is retained for the higher-rate OC-N card.

To perform a span upgrade on either the OC192-XFP or MRC-12 card with an SFP/XFP (known as pluggable port modules, PPMs, in CTC), the higher-rate PPM must replace the lower-rate PPM in the same slot. If you are using a multi-rate PPM, you do not need to physically replace the PPM but can provision the PPM for a different line rate. All spans in the network must be upgraded. The 1+1 protection configuration of the original lower-rate PPM is retained for the higher-rate PPM.

When performing span upgrades on a large number of nodes, we recommend that you upgrade all spans in a ring consecutively and in the same maintenance window. Until all spans are upgraded, mismatched card types or PPM types are present.

We recommend using the Span Upgrade Wizard to perform span upgrades. Although you can also use the manual span upgrade procedures, the manual procedures are mainly provided as error recovery for the wizard. The Span Upgrade Wizard and the Manual Span Upgrade procedures require at least two technicians (one at each end of the span) who can communicate with each other during the upgrade. Upgrading a span is non-service affecting and causes no more than three switches, each of which is less than 50 ms in duration.

**Note**

Span upgrades do not upgrade SONET topologies (for example, a 1+1 group to a two-fiber BLSR). Refer to the *Cisco ONS 15454 Procedure Guide* for topology upgrade procedures.

12.7.1 Span Upgrade Wizard

The Span Upgrade Wizard automates all steps in the manual span upgrade procedure (BLSR, path protection, and 1+1). The wizard can upgrade both lines on one side of a four-fiber BLSR or both lines of a 1+1 group; the wizard upgrades path protection configurations and two-fiber BLSRs one line at a time. The Span Upgrade Wizard requires that all working spans have DCC enabled.

The Span Upgrade Wizard provides no way to back out of an upgrade. In the case of an error, you must exit the wizard and initiate the manual procedure to either continue with the upgrade or back out of it. To continue with the manual procedure, examine the standing conditions and alarms to identify the stage in which the wizard failure occurred.

12.7.2 Manual Span Upgrades

Manual span upgrades are mainly provided as error recovery for the Span Upgrade Wizard, but they can be used to perform span upgrades. Downgrading can be performed to back out of a span upgrade. The procedure for downgrading is the same as upgrading except that you choose a lower-rate card type. You cannot downgrade if circuits exist on the STSs that will be removed (the higher STSs).

Procedures for manual span upgrades can be found in the “Upgrade Cards and Spans” chapter in the *Cisco ONS 15454 Procedure Guide*. Five manual span upgrade options are available:

- Upgrade on a two-fiber BLSR
- Upgrade on a four-fiber BLSR
- Upgrade on a path protection
- Upgrade on a 1+1 protection group
- Upgrade on an unprotected span

12.8 In-Service Topology Upgrades

Topology upgrades can be performed in-service to convert a live network to a different topology. An in-service topology upgrade is potentially service-affecting, and generally allows a traffic hit of 50 ms or less. Traffic might not be protected during the upgrade. The following in-service topology upgrades are supported:

- Unprotected point-to-point or linear ADM to path protection
- Point-to-point or linear ADM to two-fiber BLSR
- path protection to two-fiber BLSR
- Two-fiber to four-fiber BLSR
- Node addition or removal from an existing topology

You can perform in-service topology upgrades irrespective of the service state of the involved cross-connects or circuits; however, a circuit must have a DISCOVERED status.

Circuit types supported for in-service topology upgrades are:

- STS, VT, and VT tunnels
- Virtual concatenated circuits (VCAT)
- Unidirectional and bidirectional
- Automatically routed and manually routed
- CTC-created and TL1-created
- Ethernet (unstitched)
- Multiple source and destination (both sources should be on one node and both drops on one node)

You cannot upgrade stitched Ethernet circuits during topology conversions. For in-service topology upgrade procedures, refer to the “Convert Network Configurations” chapter in the *Cisco ONS 15454 Procedure Guide*. For procedures to add or remove a node, refer to the “Add and Remove Nodes” chapter of the *Cisco ONS 15454 Procedure Guide*.

**Note**

A database restore on all nodes in a topology returns converted circuits to their original topology.

**Note**

Open-ended path protection and DRI configurations do not support in-service topology upgrades.

12.8.1 Unprotected Point-to-Point or Linear ADM to Path Protection

CTC provides a topology conversion wizard for converting an unprotected point-to-point or linear ADM topology to path protection. This conversion occurs at the circuit level. CTC calculates the additional path protection circuit route automatically or you can do it manually. When routing the path protection circuit, you can provision the USPR as go-and-return or unidirectional.

When performing an in-service topology upgrade on a configuration with VCAT circuits, CTC allows you to select member circuits to upgrade individually. When upgrading VT tunnels, CTC does not convert the VT tunnel to path protection, but instead creates a secondary tunnel for the alternate path. The result is two unprotected VT tunnels using alternate paths.

To convert from point-to-point or linear ADM to a path protection, the topology requires an additional circuit route to complete the ring. When the route is established, CTC creates circuit connections on any intermediate nodes and modifies existing circuit connections on the original circuit path. The number and position of network spans in the topology remains unchanged during and after the conversion.

Figure 12-17 shows an unprotected point-to-point ADM configuration converted to a path protection. An additional circuit routes through Node 3 to complete the path protection.

Figure 12-17 Unprotected Point-to-Point ADM to Path Protection Conversion

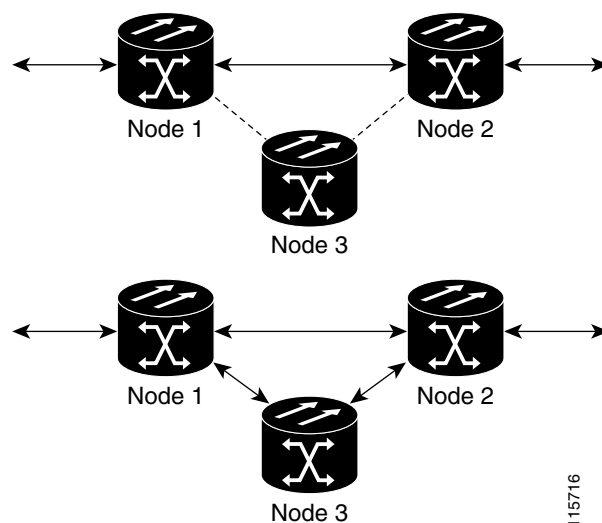

12.8.2 Point-to-Point or Linear ADM to Two-Fiber BLSR

A 1+1 point-to-point or linear ADM to a two-fiber BLSR conversion is manual. You must remove the protect fibers from all nodes in the linear ADM and route them from the end node to the protect port on the other end node. In addition, you must delete the circuit paths that are located in the bandwidth that will become the protection portion of the two-fiber BLSR (for example, circuits in STS 25 or higher on an OC-48 BLSR) and recreate them in the appropriate bandwidth. Finally, you must provision the nodes as BLSR nodes.

To complete a conversion from an unprotected point-to-point or linear ADM to a two-fiber BLSR, use the CTC Convert Unprotected/path protection to BLSR wizard from the Tools > Topology Upgrade menu.

12.8.3 Path Protection to Two-Fiber BLSR

CTC provides a topology conversion wizard to convert a path protection to a two-fiber BLSR. An upgrade from a path protection to a two-fiber BLSR changes path protection to line protection. A path protection can have a maximum of 16 nodes before conversion. Circuits paths must occupy the same time slots around the ring. Only the primary path through the path protection is needed; the topology conversion wizard removes the alternate path protection path during the conversion. Because circuit paths can begin and end outside of the topology, the conversion might create line-protected segments within path protection paths of circuits outside the scope of the ring. The physical arrangement of the ring nodes and spans remains the same after the conversion.

12.8.4 Two-Fiber BLSR to Four-Fiber BLSR

CTC provides a wizard to convert two-fiber OC-48 or OC-192 BLSRs to four-fiber BLSRs. To convert the BLSR, you must install two OC-48 or OC-192 cards at each two-fiber BLSR node, then log into CTC and convert each node from two-fiber to four-fiber. The fibers that were divided into working and protect bandwidths for the two-fiber BLSR are now fully allocated for working BLSR traffic.

12.8.5 Add or Remove a Node from a Topology

You can add or remove a node from a linear ADM, BLSR, or path protection configuration. Adding or removing nodes from BLSRs is potentially service affecting; however, adding and removing nodes from an existing 1+1 linear ADM or path protection configuration does not disrupt traffic. CTC provides a wizard for adding a node to a point-to-point or 1+1 linear ADM. This wizard is used when adding a node between two other nodes.



CHAPTER 13

Management Network Connectivity

This chapter provides an overview of ONS 15454 data communications network (DCN) connectivity. Cisco Optical Networking System (ONS) network communication is based on IP, including communication between Cisco Transport Controller (CTC) computers and ONS 15454 nodes, and communication among networked ONS 15454 nodes. The chapter provides scenarios showing Cisco ONS 15454 nodes in common IP network configurations as well as information about provisionable patchcords, the IP routing table, external firewalls, and open gateway network element (GNE) networks.

Although ONS 15454 DCN communication is based on IP, ONS 15454 nodes can be networked to equipment that is based on the Open System Interconnection (OSI) protocol suites. This chapter also describes the ONS 15454 OSI implementation and provides scenarios that show how the ONS 15454 can be networked within a mixed IP and OSI environment.



Note

This chapter does not provide a comprehensive explanation of IP networking concepts and procedures, nor does it provide IP addressing examples to meet all networked scenarios. For ONS 15454 networking setup instructions, refer to the “Turn Up a Node” chapter of the *Cisco ONS 15454 Procedure Guide*.

Chapter topics include:

- [13.1 IP Networking Overview, page 13-1](#)
- [13.2 IP Addressing Scenarios, page 13-2](#)
- [13.3 Provisionable Patchcords, page 13-24](#)
- [13.4 Routing Table, page 13-26](#)
- [13.5 External Firewalls, page 13-27](#)
- [13.6 Open GNE, page 13-29](#)
- [13.7 TCP/IP and OSI Networking, page 13-31](#)



Note

To connect ONS 15454s to an IP network, you must work with a LAN administrator or other individual at your site who has IP networking training and experience.

13.1 IP Networking Overview

ONS 15454s can be connected in many different ways within an IP environment:

- They can be connected to LANs through direct connections or a router.

- IP subnetting can create multiple logical ONS 15454 networks within a single Class A, B, or C IP network. If you do not subnet, you will only be able to use one network from your Class A, B, or C network.
- Different IP functions and protocols can be used to achieve specific network goals. For example, Proxy Address Resolution Protocol (ARP) enables one LAN-connected ONS 15454 to serve as a gateway for ONS 15454s that are not connected to the LAN.
- Static routes can be created to enable connections among multiple CTC sessions with ONS 15454s that reside on the same subnet.
- ONS 15454s can be connected to Open Shortest Path First (OSPF) networks so that ONS 15454 network information is automatically communicated across multiple LANs and WANs.
- The ONS 15454 SOCKS (network proxy protocol) proxy server can control the visibility and accessibility between CTC computers and ONS 15454 element nodes.

13.2 IP Addressing Scenarios

ONS 15454 IP addressing generally has eight common scenarios or configurations. Use the scenarios as building blocks for more complex network configurations. [Table 13-1](#) provides a general list of items to check when setting up ONS 15454 nodes in IP networks.

Table 13-1 General ONS 15454 IP Troubleshooting Checklist

Item	What to Check
Link integrity	Verify that link integrity exists between: <ul style="list-style-type: none"> • CTC computer and network hub/switch • ONS 15454s (backplane wire-wrap pins or RJ-45 port) and network hub/switch • Router ports and hub/switch ports
ONS 15454 hub/switch ports	If connectivity problems occur, set the hub or switch port that is connected to the ONS 15454 to 10 Mbps half-duplex.
Ping	Ping the node to test connections between computers and ONS 15454s.
IP addresses/subnet masks	Verify that ONS 15454 IP addresses and subnet masks are set up correctly.
Optical connectivity	Verify that ONS 15454 optical trunk (span) ports are in service and that a DCC is enabled on each trunk port.

The TCC2P card secure mode option allows two IP addresses to be provisioned for the node: one for the backplane LAN port and one for the TCC2P LAN (TCP/IP) port. Secure mode IP addressing examples are provided in the [“13.2.9 IP Scenario 9: IP Addressing with Secure Mode Enabled”](#) section on [page 13-20](#). IP addresses shown in the other scenarios assume that secure mode is not enabled. If secure mode is enabled, the IP addresses shown in the examples apply to the backplane LAN port. See the [“13.2.9 IP Scenario 9: IP Addressing with Secure Mode Enabled”](#) section on [page 13-20](#) for information about secure mode, repeater (single IP address) mode, and configuration locks.

13.2.1 IP Scenario 1: CTC and ONS 15454s on Same Subnet

IP Scenario 1 shows a basic ONS 15454 LAN configuration (Figure 13-1). The ONS 15454s and CTC computer reside on the same subnet. All ONS 15454s connect to LAN A, and all ONS 15454s have DCC connections.

Figure 13-1 IP Scenario 1: CTC and ONS 15454s on Same Subnet

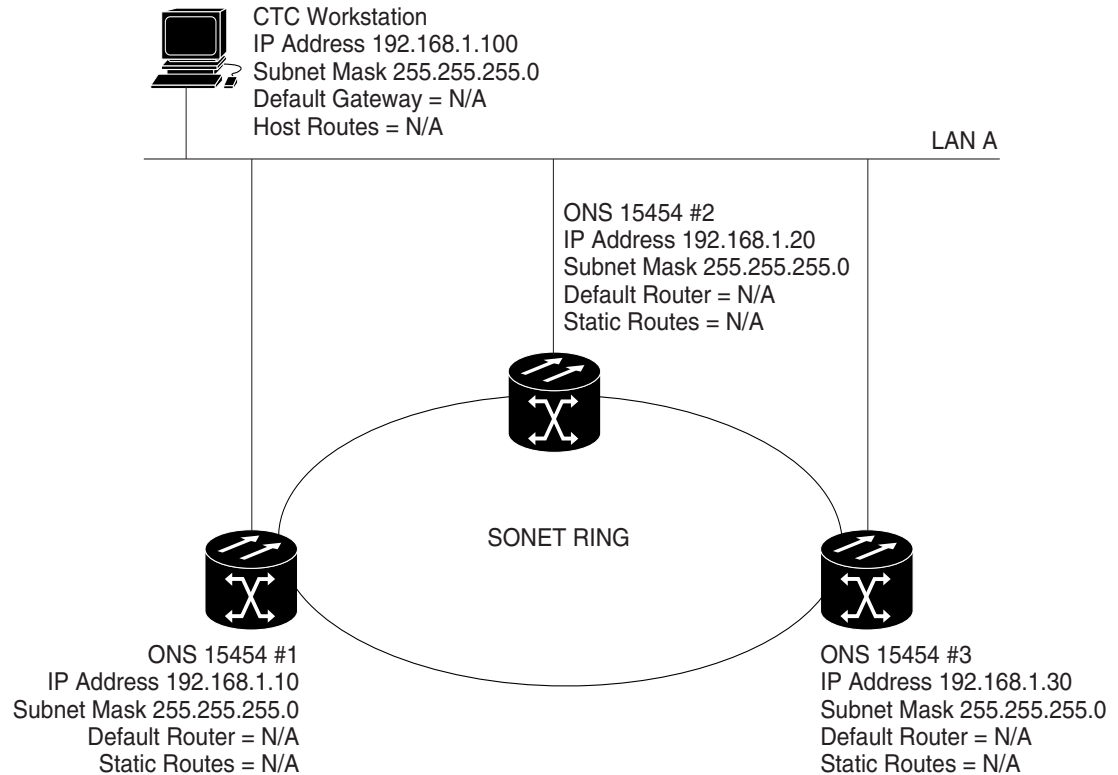

33157

13.2.2 IP Scenario 2: CTC and ONS 15454 Nodes Connected to a Router

In IP Scenario 2 the CTC computer resides on a subnet (192.168.1.0) and attaches to LAN A (Figure 13-2). The ONS 15454s reside on a different subnet (192.168.2.0) and attach to LAN B. A router connects LAN A to LAN B. The IP address of router interface A is set to LAN A (192.168.1.1), and the IP address of router interface B is set to LAN B (192.168.2.1).

On the CTC computer, the default gateway is set to router interface A. If the LAN uses Dynamic Host Configuration Protocol (DHCP), the default gateway and IP address are assigned automatically. In the Figure 13-2 example, a DHCP server is not available.

Figure 13-2 IP Scenario 2: CTC and ONS 15454 Nodes Connected to a Router

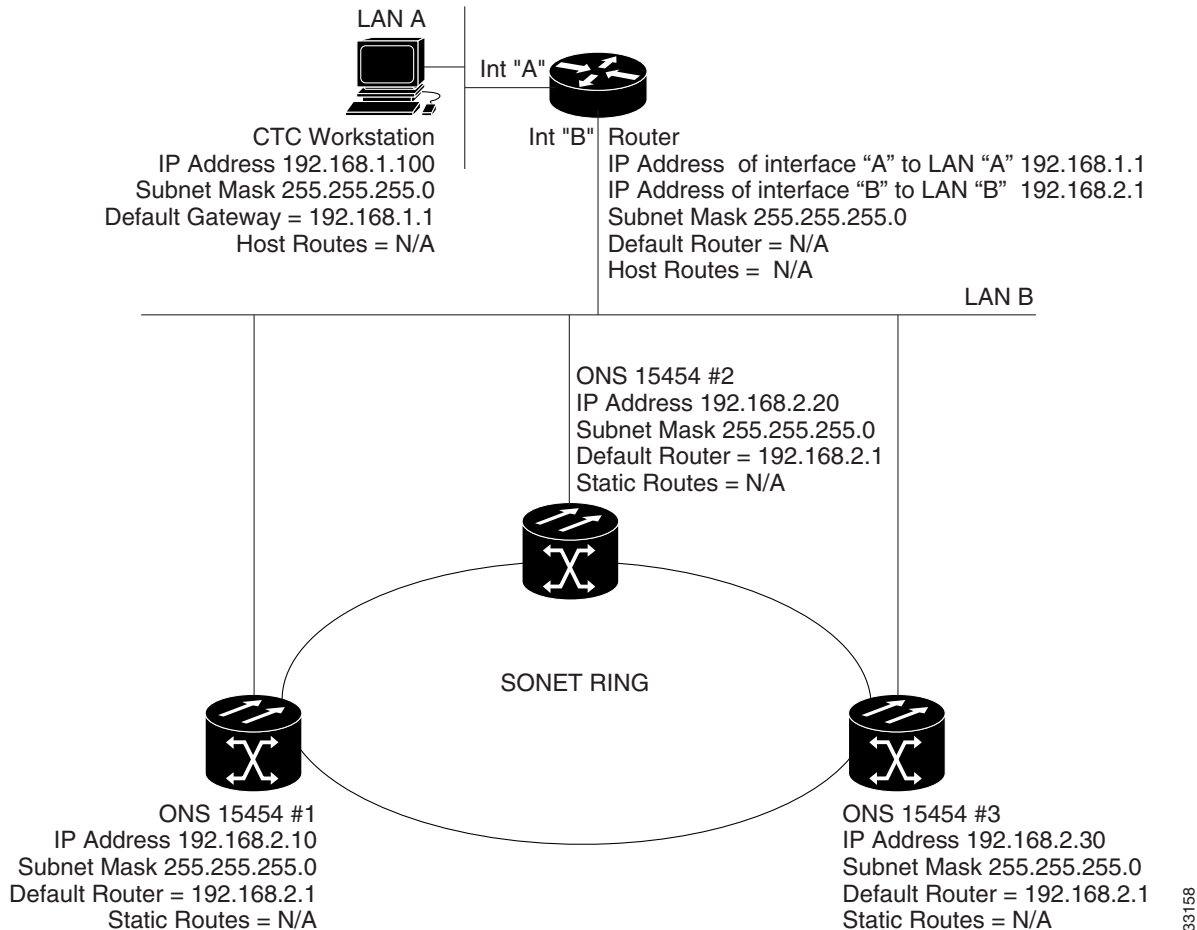

13.2.3 IP Scenario 3: Using Proxy ARP to Enable an ONS 15454 Gateway

ARP matches higher-level IP addresses to the physical addresses of the destination host. It uses a lookup table (called ARP cache) to perform the translation. When the address is not found in the ARP cache, a broadcast is sent out on the network with a special format called the ARP request. If one of the machines on the network recognizes its own IP address in the request, it sends an ARP reply back to the requesting host. The reply contains the physical hardware address of the receiving host. The requesting host stores this address in its ARP cache so that all subsequent datagrams (packets) to this destination IP address can be translated to a physical address.

Proxy ARP enables one LAN-connected ONS 15454 to respond to the ARP request for ONS 15454s not connected to the LAN. (ONS 15454 proxy ARP requires no user configuration.) For this to occur, the DCC-connected ONS 15454s must reside on the same subnet. When a LAN device sends an ARP request to an ONS 15454 that is not connected to the LAN, the gateway ONS 15454 returns its MAC address to the LAN device. The LAN device then sends the datagram for the remote ONS 15454 to the MAC address of the proxy ONS 15454. The proxy ONS 15454 uses its routing table to forward the datagram to the non-LAN ONS 15454.

IP Scenario 3 is similar to IP Scenario 1, but only one ONS 15454 (1) connects to the LAN (Figure 13-3). Two ONS 15454s (2 and 3) connect to ONS 15454 1 through the SONET DCC. Because all three ONS 15454s are on the same subnet, proxy ARP enables ONS 15454 1 to serve as a gateway for ONS 15454 2 and 3.

**Note**

This scenario assumes all CTC connections are to Node 1. If you connect a laptop to either ONS 15454 2 or 3, network partitioning occurs; neither the laptop nor the CTC computer can see all nodes. If you want laptops to connect directly to end network elements, you must create static routes (see “13.2.5 IP Scenario 5: Using Static Routes to Connect to LANs” section on page 13-7) or enable the ONS 15454 SOCKS proxy server (see “13.2.7 IP Scenario 7: Provisioning the ONS 15454 SOCKS Proxy Server” section on page 13-12).

Figure 13-3 IP Scenario 3: Using Proxy ARP

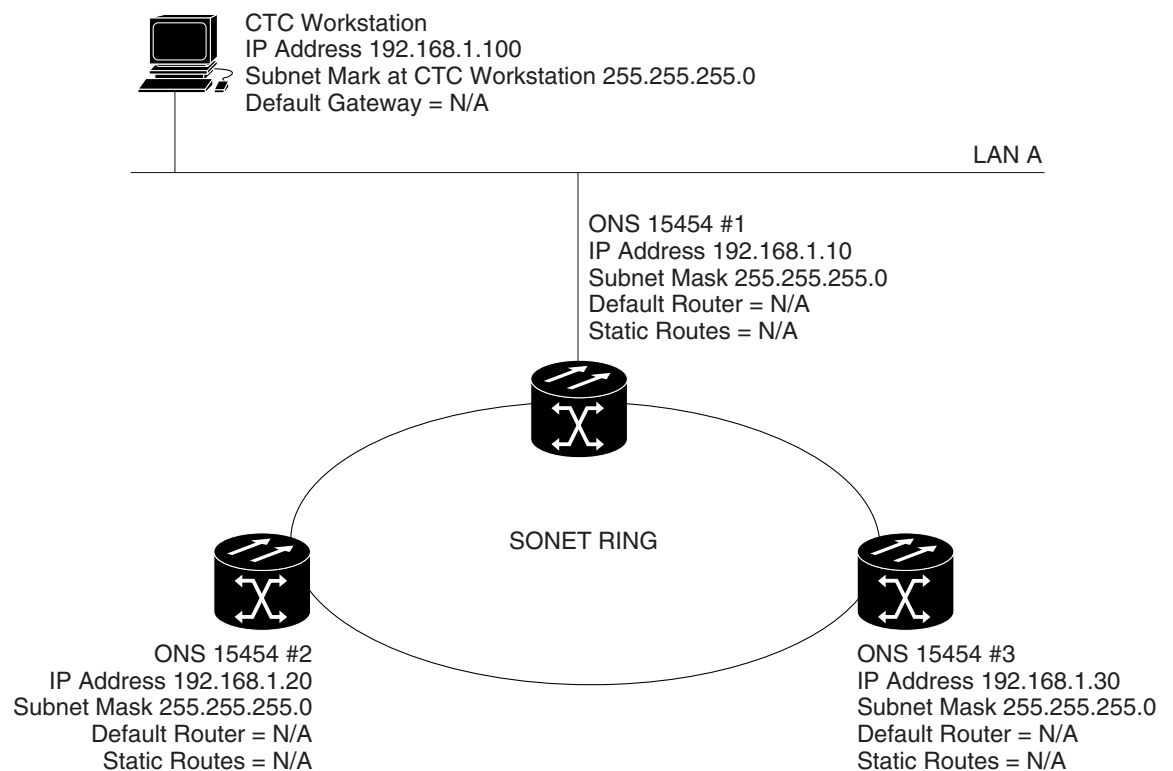

You can also use proxy ARP to communicate with hosts attached to the craft Ethernet ports of DCC-connected nodes (Figure 13-4). The node with an attached host must have a static route to the host. Static routes are propagated to all DCC peers using OSPF. The existing proxy ARP node is the gateway for additional hosts. Each node examines its routing table for routes to hosts that are not connected to the DCC network but are within the subnet. The existing proxy server replies to ARP requests for these additional hosts with the node MAC address. The existence of the host route in the routing table ensures that the IP packets addressed to the additional hosts are routed properly. Other than establishing a static route between a node and an additional host, no provisioning is necessary. The following restrictions apply:

- Only one node acts as the proxy ARP server for any given additional host.
- A node cannot be the proxy ARP server for a host connected to its Ethernet port.

In [Figure 13-4](#), Node 1 announces to Node 2 and 3 that it can reach the CTC host. Similarly, Node 3 announces that it can reach the ONS 152xx. The ONS 152xx is shown as an example; any network element (NE) can be set up as an additional host.

Figure 13-4 IP Scenario 3: Using Proxy ARP with Static Routing

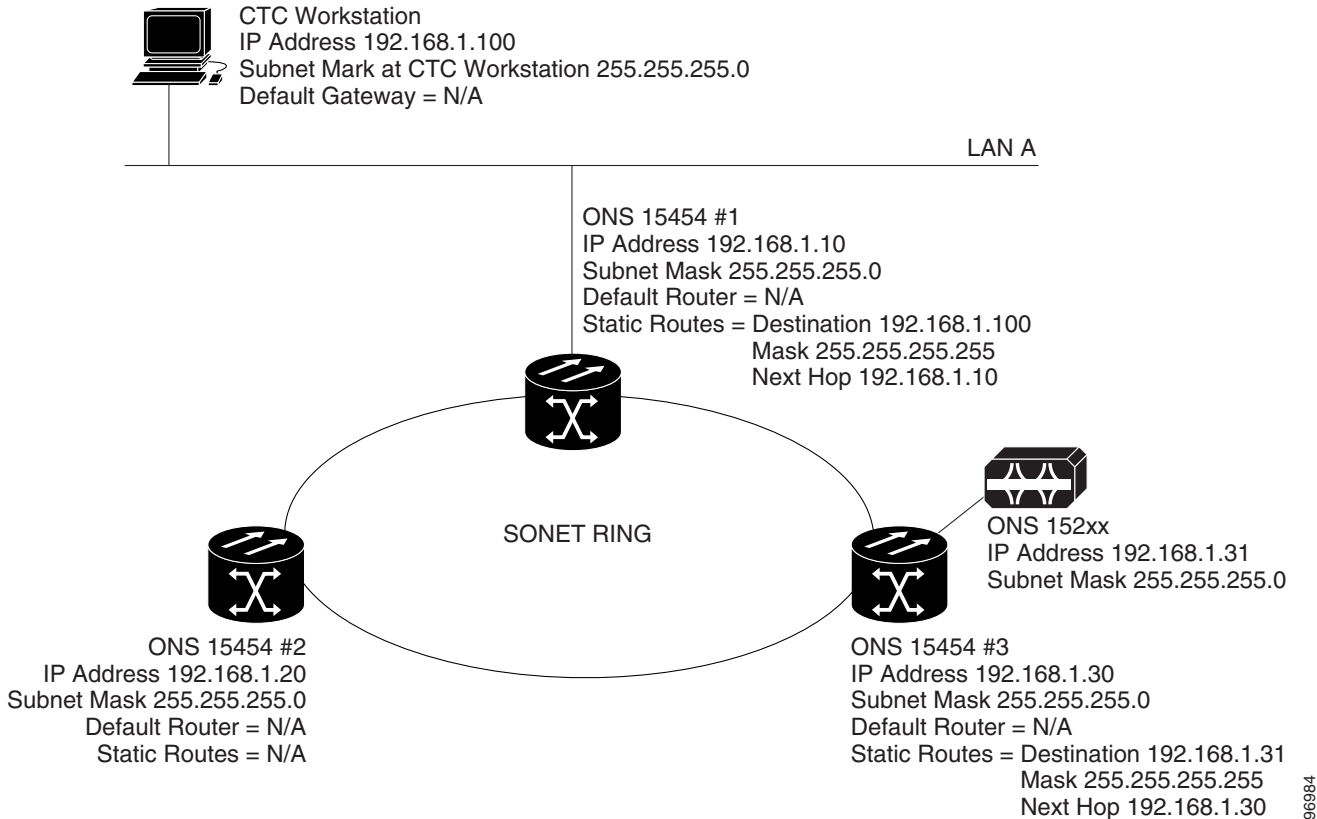

13.2.4 IP Scenario 4: Default Gateway on a CTC Computer

IP Scenario 4 is similar to IP Scenario 3, but Nodes 2 and 3 reside on different subnets, 192.168.2.0 and 192.168.3.0, respectively ([Figure 13-5](#)). Node 1 and the CTC computer are on subnet 192.168.1.0. Proxy ARP is not used because the network includes different subnets. For the CTC computer to communicate with Nodes 2 and 3, Node 1 is entered as the default gateway on the CTC computer.

Figure 13-5 IP Scenario 4: Default Gateway on a CTC Computer

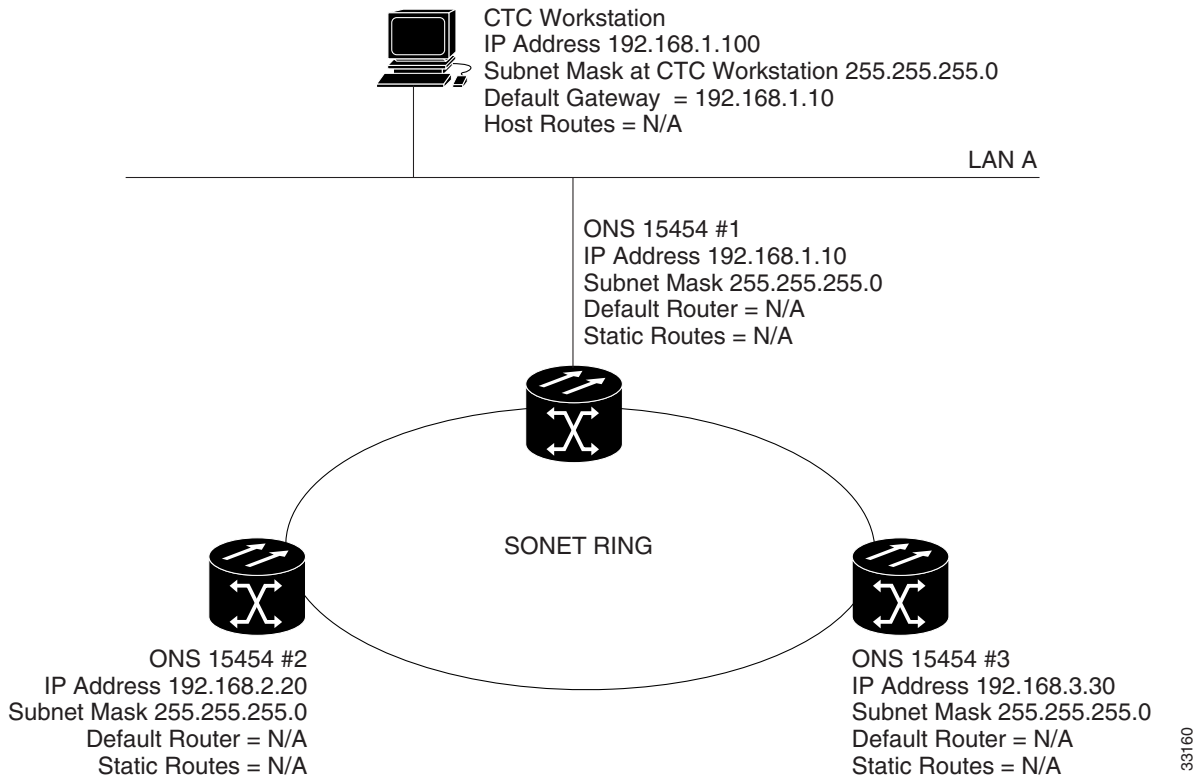

13.2.5 IP Scenario 5: Using Static Routes to Connect to LANs

Static routes are used for two purposes:

- To connect ONS 15454s to CTC sessions on one subnet connected by a router to ONS 15454s residing on another subnet. (These static routes are not needed if OSPF is enabled. “[13.2.6 IP Scenario 6: Using OSPF](#)” section on page 13-10 shows an OSPF example.)
- To enable multiple CTC sessions among ONS 15454s residing on the same subnet.

In [Figure 13-6](#), one CTC residing on subnet 192.168.1.0 connects to a router through interface A. (The router is not set up with OSPF.) ONS 15454s residing on different subnets are connected through Node 1 to the router through interface B. Because Nodes 2 and 3 are on different subnets, proxy ARP does not enable Node 1 as a gateway. To connect to the CTC computer on LAN A (subnet 192.168.1.0), you must create a static route on Node 1. You must also manually add static routes between the CTC computer on LAN A and Nodes 2 and 3 because these nodes are on different subnets.

Figure 13-6 IP Scenario 5: Static Route With One CTC Computer Used as a Destination

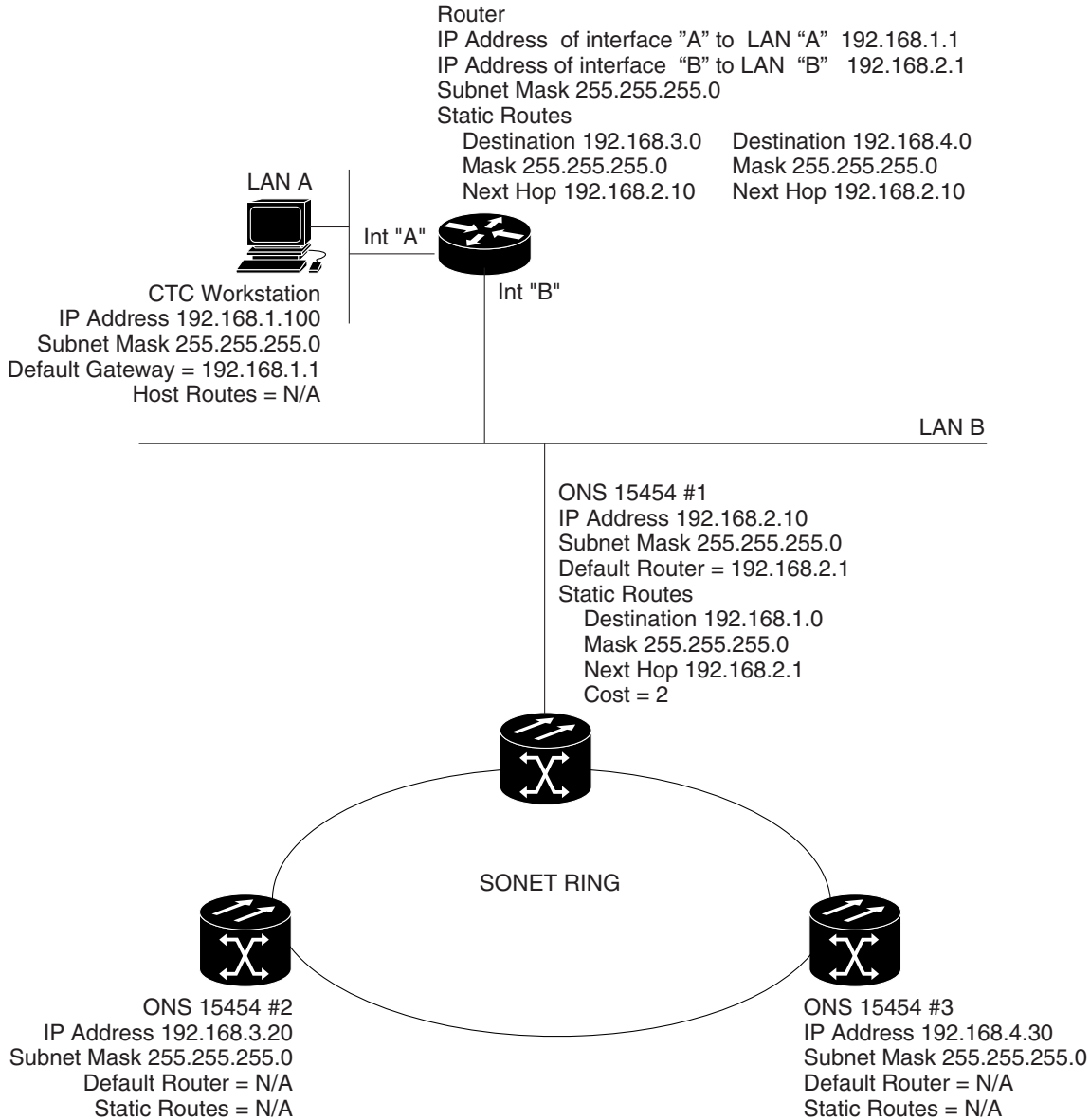

The destination and subnet mask entries control access to the ONS 15454s:

- If a single CTC computer is connected to a router, enter the complete CTC “host route” IP address as the destination with a subnet mask of 255.255.255.255.
- If CTC computers on a subnet are connected to a router, enter the destination subnet (in this example, 192.168.1.0) and a subnet mask of 255.255.255.0.
- If all CTC computers are connected to a router, enter a destination of 0.0.0.0 and a subnet mask of 0.0.0.0. [Figure 13-7](#) shows an example.

The IP address of router interface B is entered as the next hop, and the cost (number of hops from source to destination) is 2. You must manually add static routes between the CTC computers on LAN A, B, and C and Nodes 2 and 3 because these nodes are on different subnets.

Figure 13-7 IP Scenario 5: Static Route With Multiple LAN Destinations

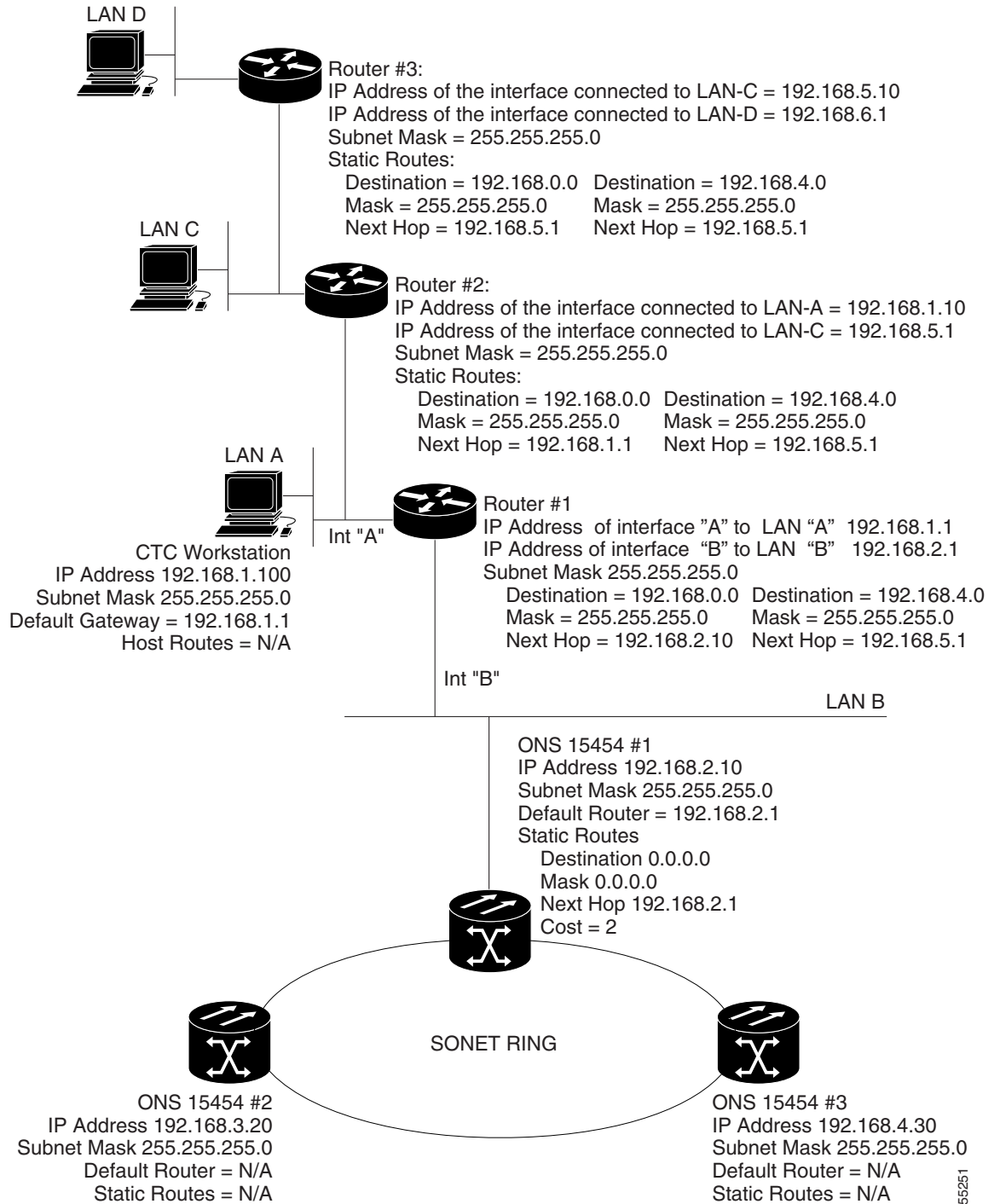

55251

13.2.6 IP Scenario 6: Using OSPF

Open Shortest Path First (OSPF) is a link state Internet routing protocol. Link state protocols use a “hello protocol” to monitor their links with adjacent routers and to test the status of their links to their neighbors. Link state protocols advertise their directly connected networks and their active links. Each link state router captures the link state “advertisements” and puts them together to create a topology of the entire network or area. From this database, the router calculates a routing table by constructing a shortest path tree. Routes are recalculated when topology changes occur.

ONS 15454s use the OSPF protocol in internal ONS 15454 networks for node discovery, circuit routing, and node management. You can enable OSPF on the ONS 15454s so that the ONS 15454 topology is sent to OSPF routers on a LAN. Advertising the ONS 15454 network topology to LAN routers eliminates the need to manually enter static routes for ONS 15454 subnetworks. [Figure 13-8](#) shows a network enabled for OSPF. [Figure 13-9](#) shows the same network without OSPF. Static routes must be manually added to the router for CTC computers on LAN A to communicate with Nodes 2 and 3 because these nodes reside on different subnets.

OSPF divides networks into smaller regions, called areas. An area is a collection of networked end systems, routers, and transmission facilities organized by traffic patterns. Each OSPF area has a unique ID number, known as the area ID. Every OSPF network has one backbone area called “area 0.” All other OSPF areas must connect to area 0.

When you enable an ONS 15454 OSPF topology for advertising to an OSPF network, you must assign an OSPF area ID in decimal format to the ONS 15454 network. Coordinate the area ID number assignment with your LAN administrator. All DCC-connected ONS 15454s should be assigned the same OSPF area ID.

Figure 13-8 IP Scenario 6: OSPF Enabled

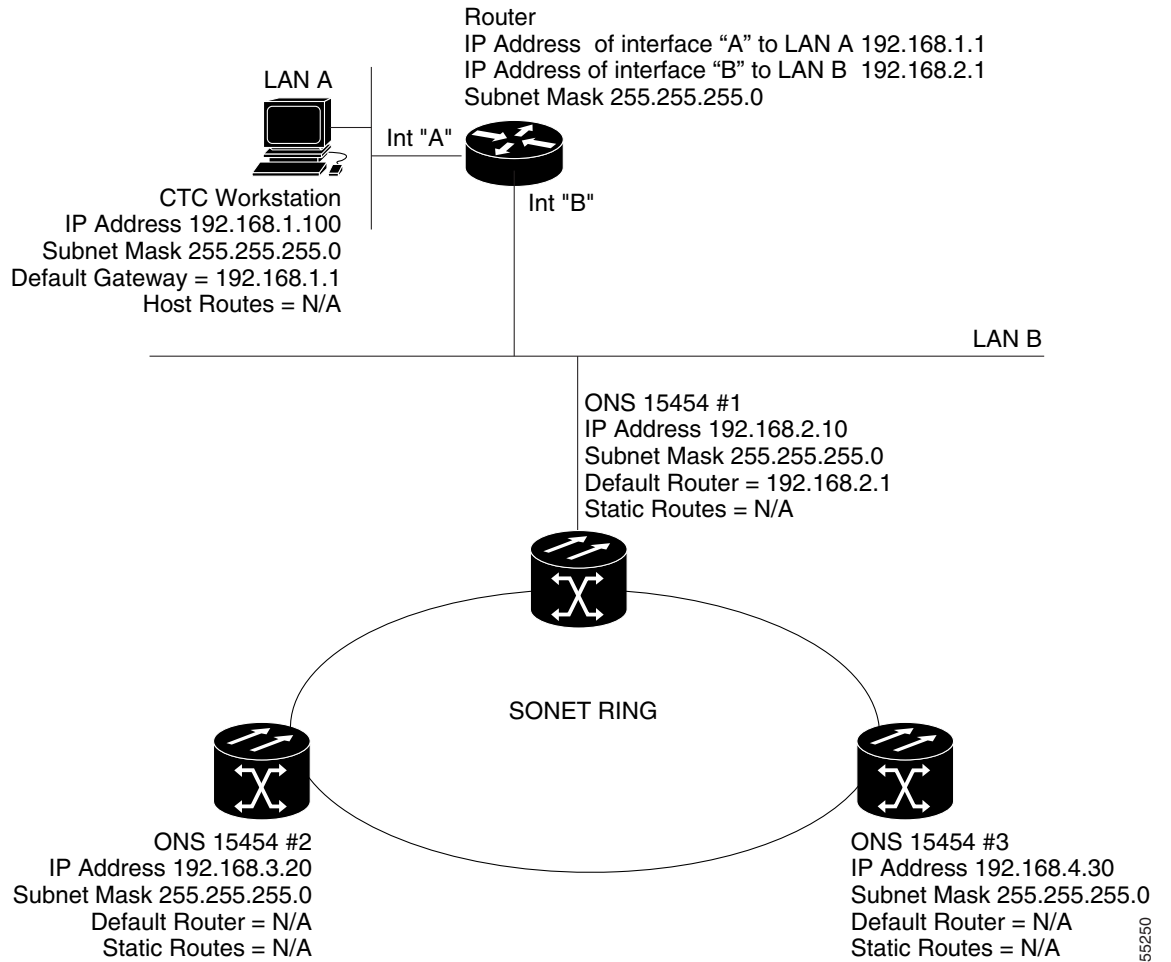

55250

Figure 13-9 IP Scenario 6: OSPF Not Enabled

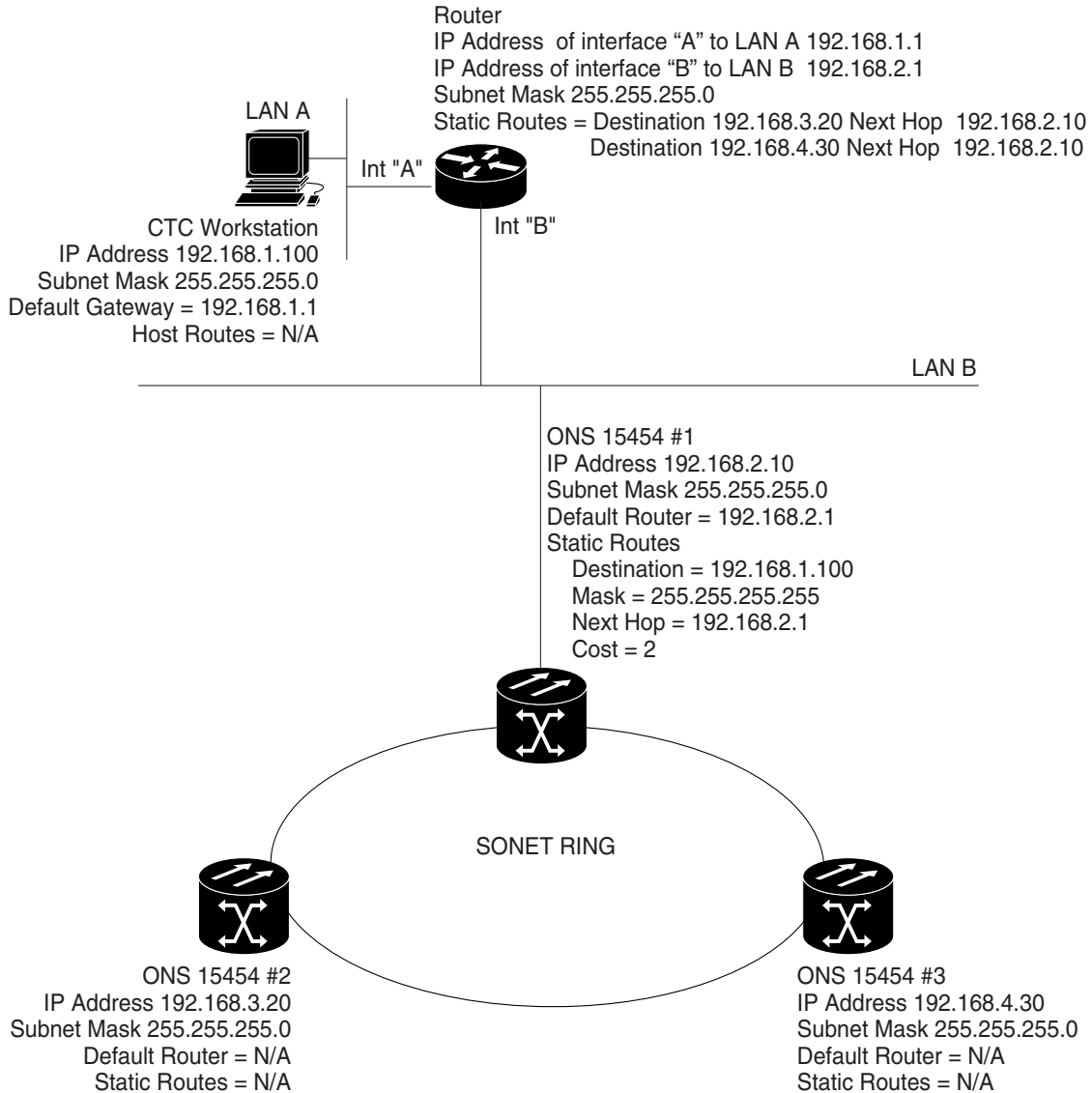

33161

13.2.7 IP Scenario 7: Provisioning the ONS 15454 SOCKS Proxy Server

The ONS 15454 SOCKS proxy is an application that allows an ONS 15454 node to serve as an internal gateway between a private enterprise network and the ONS 15454 network. (SOCKS is a standard proxy protocol for IP-based applications developed by the Internet Engineering Task Force.) Access is allowed from the private network to the ONS 15454 network, but access is denied from the ONS 15454 network to the private network. For example, you can set up a network so that field technicians and network operations center (NOC) personnel can both access the same ONS 15454s while preventing the field technicians from accessing the NOC LAN. To do this, one ONS 15454 is provisioned as a gateway network element (GNE) and the other ONS 15454s are provisioned as end network elements (ENEs). The GNE ONS 15454 tunnels connections between CTC computers and ENE ONS 15454s, providing management capability while preventing access for non-ONS 15454 management purposes.

The ONS 15454 gateway setting performs the following tasks:

- Isolates DCC IP traffic from Ethernet (craft port) traffic and accepts packets based on filtering rules. The filtering rules (see [Table 13-3 on page 13-17](#) and [Table 13-4 on page 13-18](#)) depend on whether the packet arrives at the ONS 15454 DCC or the TCC2/TCC2P Ethernet interface.
- Processes Simple Network Time Protocol (SNTP) and Network Time Protocol (NTP) requests. ONS 15454 ENEs can derive time-of-day from an SNTP/NTP LAN server through the GNE ONS 15454.
- Processes Simple Network Management Protocol version 1 (SNMPv1) traps. The GNE ONS 15454 receives SNMPv1 traps from the ENE ONS 15454s and forwards or relays the traps to SNMPv1 trap destinations or ONS 15454 SNMP relay nodes.

The ONS 15454 SOCKS proxy server is provisioned using the Enable SOCKS proxy server on port check box on the Provisioning > Network > General tab ([Figure 13-10](#)).

Figure 13-10 SOCKS Proxy Server Gateway Settings

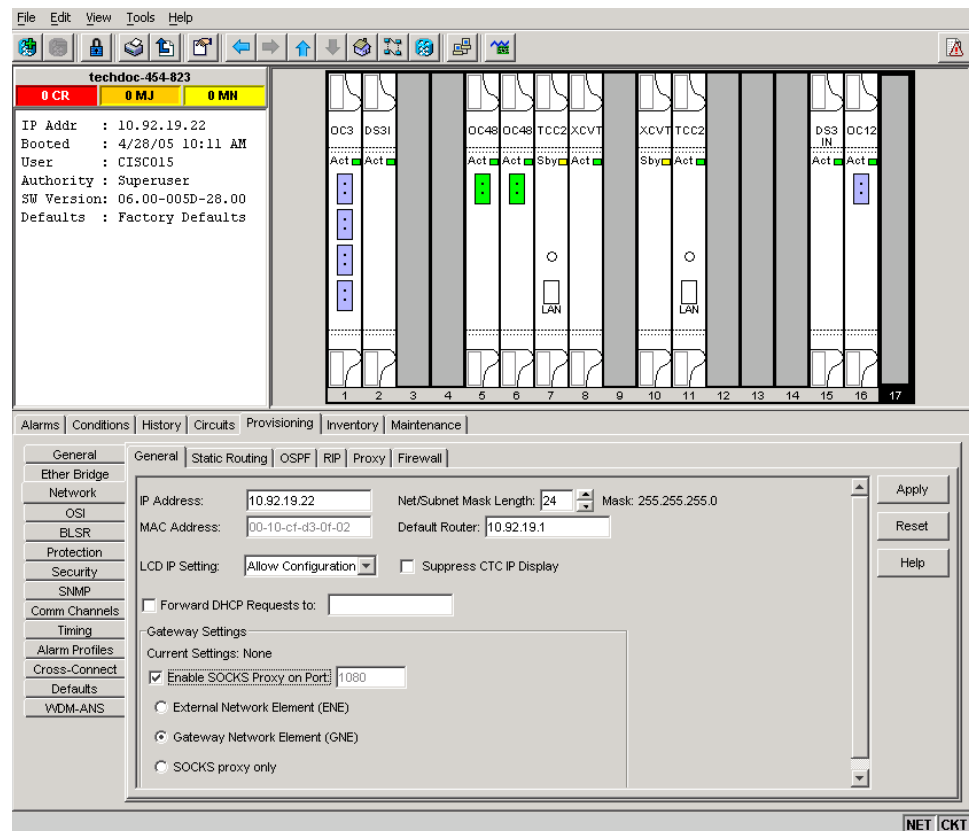

If checked, the ONS 15454 serves as a proxy for connections between CTC clients and ONS 15454s that are DCC-connected to the proxy ONS 15454. The CTC client establishes connections to DCC-connected nodes through the proxy node. The CTC client can connect to nodes that it cannot directly reach from the host on which it runs. If not selected, the node does not proxy for any CTC clients, although any established proxy connections continue until the CTC client exits. In addition, you can set the SOCKS proxy server as an ENE or a GNE:

**Note**

If you launch CTC against a node through a Network Address Translation (NAT) or Port Address Translation (PAT) router and that node does not have proxy enabled, your CTC session starts and initially appears to be fine. However, CTC never receives alarm updates and disconnects and reconnects every two minutes. If the proxy is accidentally disabled, it is still possible to enable the proxy during a reconnect cycle and recover your ability to manage the node, even through a NAT/PAT firewall.

- **External Network Element (ENE)**—If set as an ENE, the ONS 15454 neither installs nor advertises default or static routes. CTC computers can communicate with the ONS 15454 using the TCC2/TCC2P craft port, but they cannot communicate directly with any other DCC-connected ONS 15454.

In addition, firewall is enabled, which means that the node prevents IP traffic from being routed between the DCC and the LAN port. The ONS 15454 can communicate with machines connected to the LAN port or connected through the DCC. However, the DCC-connected machines cannot communicate with the LAN-connected machines, and the LAN-connected machines cannot communicate with the DCC-connected machines. A CTC client using the LAN to connect to the firewall-enabled node can use the proxy capability to manage the DCC-connected nodes that would otherwise be unreachable. A CTC client connected to a DCC-connected node can only manage other DCC-connected nodes and the firewall itself.

- **Gateway Network Element (GNE)**—If set as a GNE, the CTC computer is visible to other DCC-connected nodes and firewall is enabled.
- **Proxy-only**—If Proxy-only is selected, firewall is not enabled. CTC can communicate with any other DCC-connected ONS 15454s.

Figure 13-11 shows an ONS 15454 SOCKS proxy server implementation. A GNE ONS 15454 is connected to a central office LAN and to ENE ONS 15454s. The central office LAN is connected to a NOC LAN, which has CTC computers. Both the NOC CTC computer and the craft technicians must be able to access the ONS 15454 ENEs. However, the craft technicians must be prevented from accessing or seeing the NOC or central office LANs.

In the example, the ONS 15454 GNE is assigned an IP address within the central office LAN and is physically connected to the LAN through its LAN port. ONS 15454 ENEs are assigned IP addresses that are outside the central office LAN and are given private network IP addresses. If the ONS 15454 ENEs are collocated, the craft LAN ports could be connected to a hub. However, the hub should have no other network connections.

Figure 13-11 IP Scenario 7: ONS 15454 SOCKS Proxy Server with GNE and ENEs on the Same Subnet

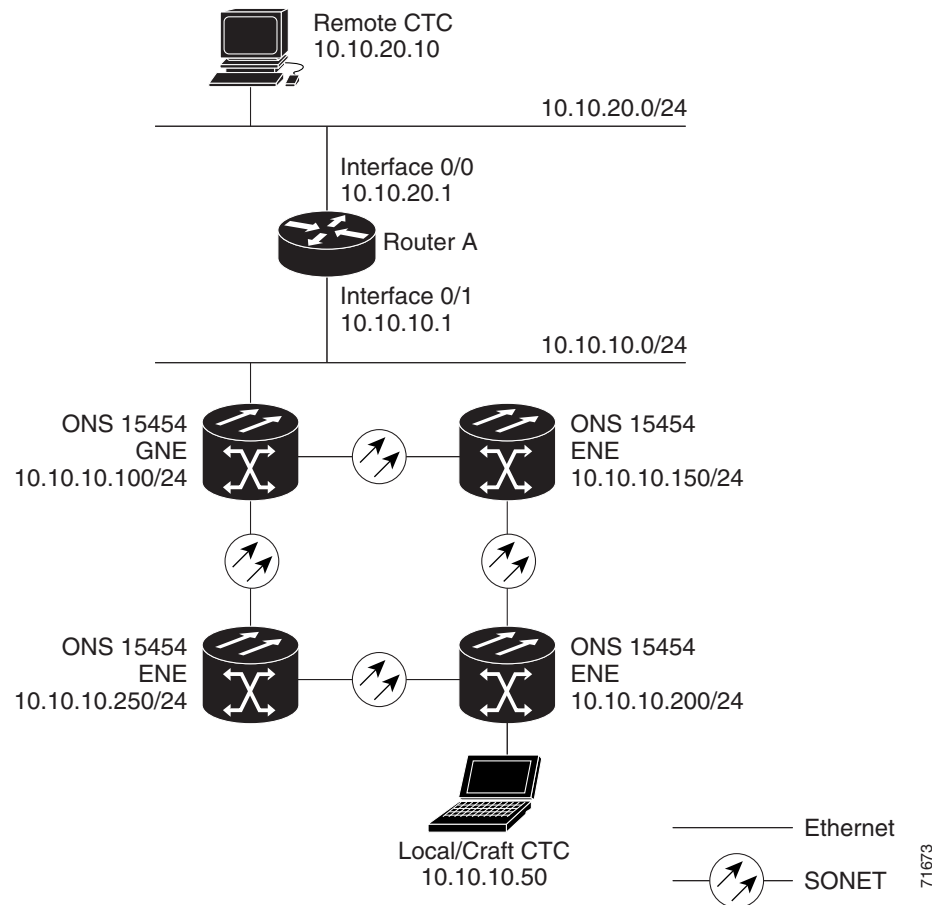

Table 13-2 shows recommended settings for ONS 15454 GNEs and ENEs in the configuration shown in Figure 13-11.

Table 13-2 ONS 15454 Gateway and End NE Settings

Setting	ONS 15454 Gateway NE	ONS 15454 End NE
OSPF	Off	Off
SNTP server (if used)	SNTP server IP address	Set to ONS 15454 GNE IP address
SNMP (if used)	SNMPv1 trap destinations	Set SNMPv1 trap destinations to ONS 15454 GNE, port 391

Figure 13-12 shows the same SOCKS proxy server implementation with ONS 15454 ENEs on different subnets. Figure 13-13 on page 13-17 shows the implementation with ONS 15454 ENEs in multiple rings. In each example, ONS 15454 GNEs and ENEs are provisioned with the settings shown in Table 13-2.

Figure 13-12 IP Scenario 7: ONS 15454 SOCKS Proxy Server with GNE and ENes on Different Subnets

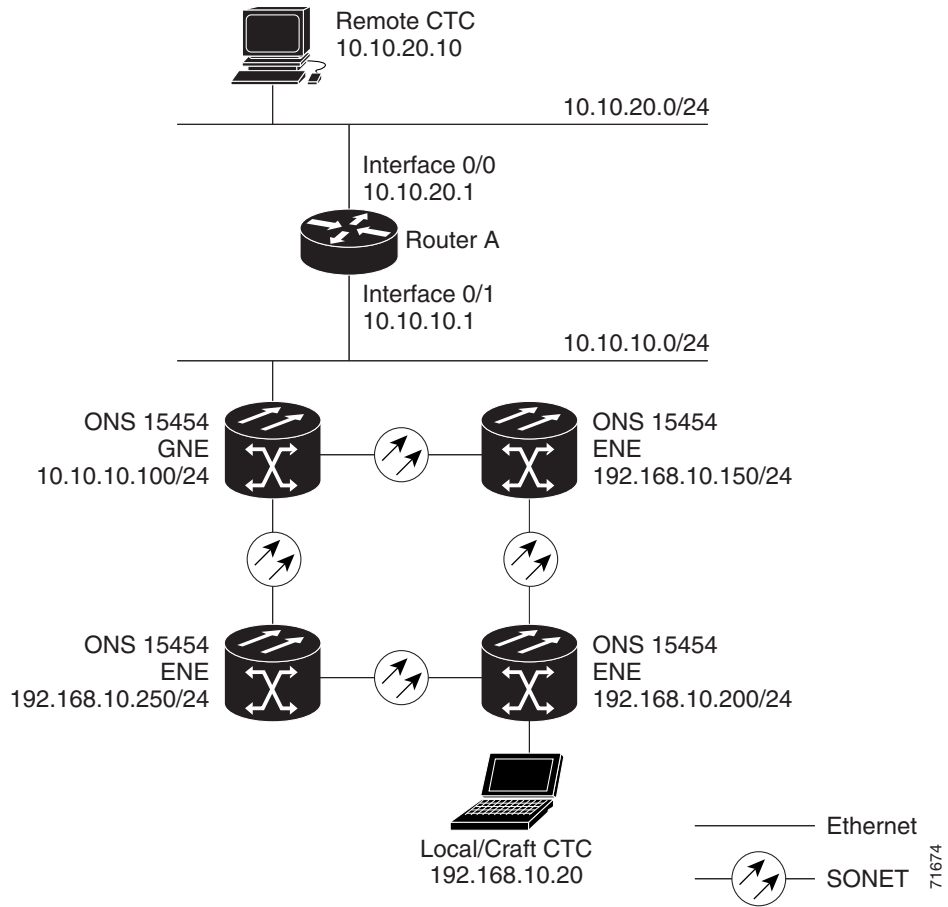

Figure 13-13 IP Scenario 7: ONS 15454 SOCKS Proxy Server With ENEs on Multiple Rings

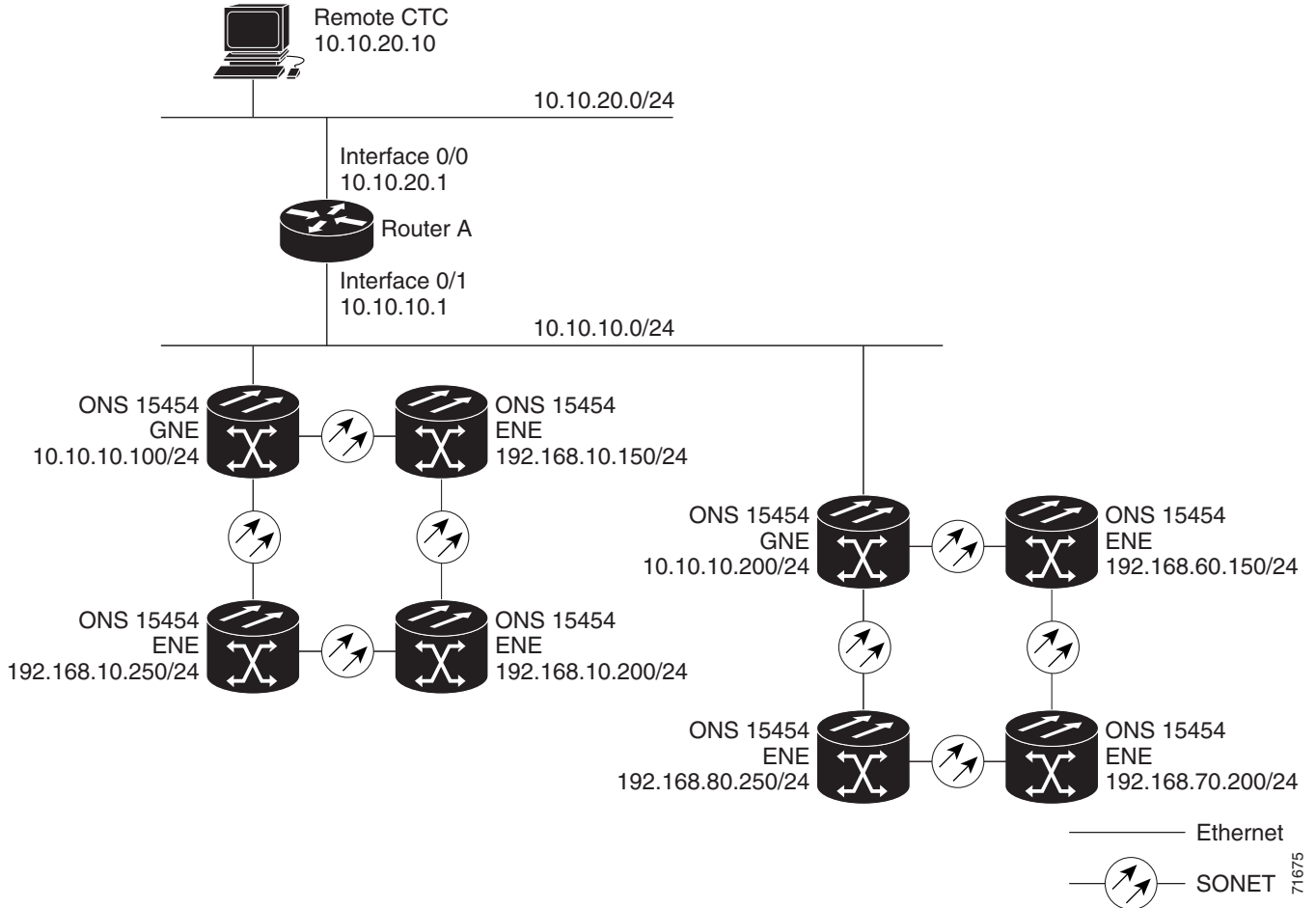

Table 13-3 shows the rules that the ONS 15454 follows to filter packets for the firewall when nodes are configured as ENEs and GNEs.

Table 13-3 SOCKS Proxy Server Firewall Filtering Rules

Packets Arriving At:	Are Accepted if the Destination IP Address is:
TCC2/TCC2P Ethernet interface	<ul style="list-style-type: none"> The ONS 15454 node itself The ONS 15454 node's subnet broadcast address Within the 224.0.0.0/8 network (reserved network used for standard multicast messages) Subnet mask = 255.255.255.255
DCC interface	<ul style="list-style-type: none"> The ONS 15454 node itself Any destination connected through another DCC interface Within the 224.0.0.0/8 network

If the packet is addressed to the ONS 15454 node, additional rules, shown in Table 13-4, are applied. Rejected packets are silently discarded.

Table 13-4 *SOCKS Proxy Server Firewall Filtering Rules When Packet Addressed to the ONS 15454*

Packets Arriving At	Accepts	Rejects
TCC2/TCC2P Ethernet interface	<ul style="list-style-type: none"> All UDP¹ packets except those in the Rejected column 	<ul style="list-style-type: none"> UDP packets addressed to the SNMP trap relay port (391)
DCC interface	<ul style="list-style-type: none"> All UDP packets All TCP² protocols except packets addressed to the Telnet and SOCKS proxy server ports OSPF packets ICMP³ packets 	<ul style="list-style-type: none"> TCP packets addressed to the Telnet port TCP packets addressed to the SOCKS proxy server port All packets other than UDP, TCP, OSPF, ICMP

1. UDP = User Datagram Protocol

2. TCP = Transmission Control Protocol

3. ICMP = Internet Control Message Protocol

If you implement the SOCKS proxy server, note that all DCC-connected ONS 15454s on the same Ethernet segment must have the same gateway setting. Mixed values produce unpredictable results, and might leave some nodes unreachable through the shared Ethernet segment.

If nodes become unreachable, correct the setting with one of the following actions:

- Disconnect the craft computer from the unreachable ONS 15454. Connect to the ONS 15454 through another network ONS 15454 that has a DCC connection to the unreachable ONS 15454.
- Disconnect all DCCs to the node by disabling them on neighboring nodes. Connect a CTC computer directly to the ONS 15454 and change its provisioning.

13.2.8 IP Scenario 8: Dual GNEs on a Subnet

The ONS 15454 provides GNE load balancing, which allows CTC to reach ENEs over multiple GNEs without the ENEs being advertised over OSPF. This feature allows a network to quickly recover from the loss of a GNE, even if the GNE is on a different subnet. If a GNE fails, all connections through that GNE fail. CTC disconnects from the failed GNE and from all ENEs for which the GNE was a proxy, and then reconnects through the remaining GNEs. GNE load balancing reduces the dependency on the launch GNE and DCC bandwidth, both of which enhance CTC performance. [Figure 13-14](#) shows a network with dual GNEs on the same subnet.

Figure 13-14 IP Scenario 8: Dual GNEs on the Same Subnet

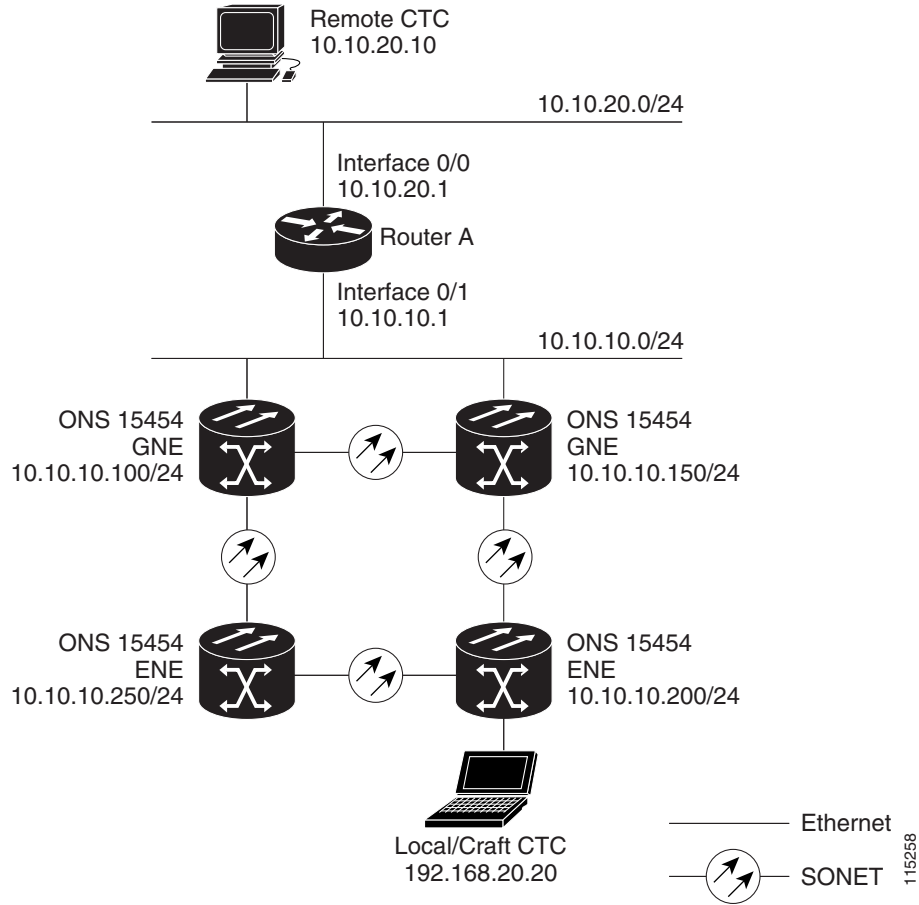
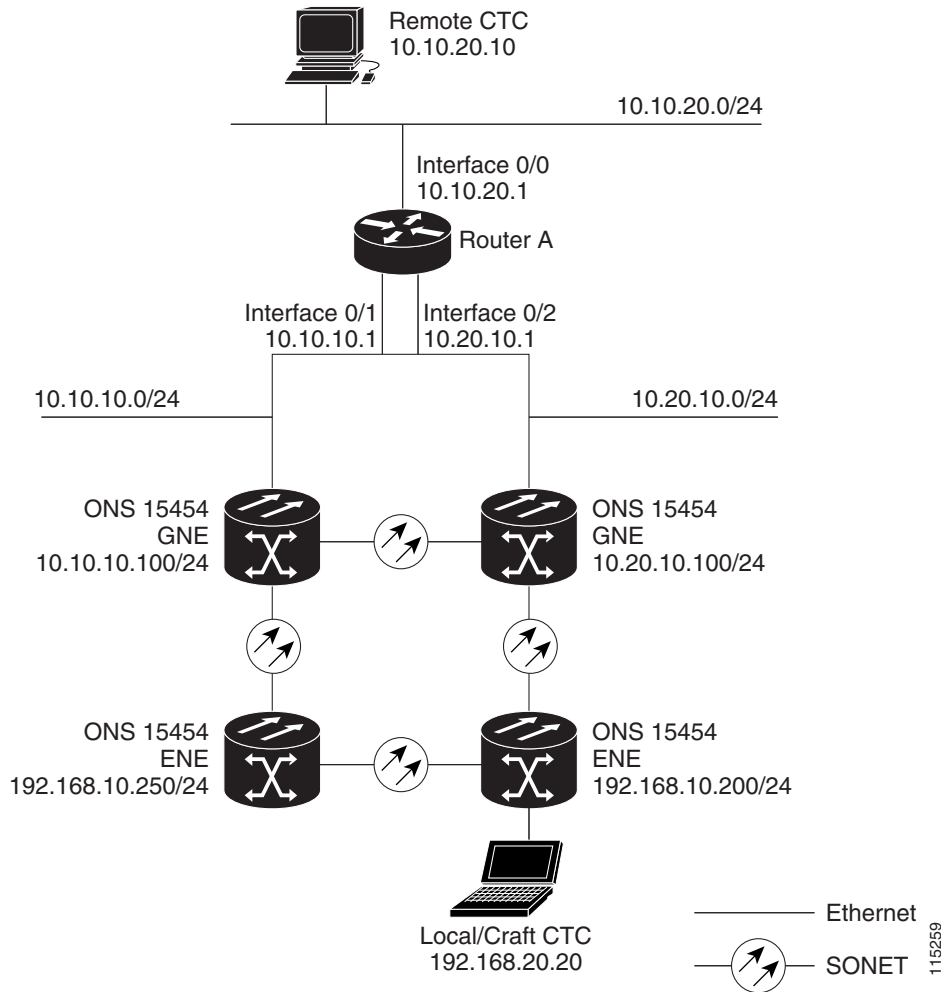

Figure 13-15 shows a network with dual GNEs on different subnets.

Figure 13-15 IP Scenario 8: Dual GNEs on Different Subnets



13.2.9 IP Scenario 9: IP Addressing with Secure Mode Enabled

The TCC2 card and TCC2P card both default to repeater mode. In this mode, the front and back Ethernet (LAN) ports share a single MAC address and IP address. TCC2P cards allow you to place a node in secure mode, which prevents a front-access craft port user from accessing the LAN through the backplane port. Secure mode can be locked, which prevents the mode from being altered. To place a node in secure mode or to lock secure mode, refer to the “Change Node Settings” chapter in the *Cisco ONS 15454 Procedure Guide*.

13.2.9.1 Secure Mode Behavior

Changing a TCC2P node from repeater mode to secure mode allows you to provision two IP addresses for the ONS 15454 and causes the node to assign the ports different MAC addresses. In secure mode, one IP address is provisioned for the ONS 15454 backplane LAN port, and the other IP address is provisioned for the TCC2P Ethernet port. Both addresses reside on different subnets, providing an additional layer of separation between the craft access port and the ONS 15454 LAN. If secure mode is

enabled, the IP addresses provisioned for both TCC2P TCP/IP LAN ports must follow general IP addressing guidelines and must reside on different subnets from each other and the default router IP address.

In secure mode, the IP address assigned to the backplane LAN port becomes a private address, which connects the node to an Operations Support System (OSS) through a central office LAN or private enterprise network. A Superuser can configure the node to hide or reveal the backplane's LAN IP address in CTC, the routing table, or autonomous message reports.

In repeater mode, a node can be a GNE or ENE. Placing the node into secure mode automatically turns on SOCKS proxy and defaults the node to GNE status. However, the node can be changed back to an ENE. In repeater mode, an ENE's SOCKS proxy can be disabled—effectively isolating the node beyond the LAN firewall—but it cannot be disabled in secure mode. To change a node's GNE or ENE status and disable the SOCKS proxy, refer to the “Turn Up a Node” chapter in the *Cisco ONS 15454 Procedure Guide*.

**Caution**

Enabling secure mode causes the TCC2P card to reboot; a TCC2P card reboot affects traffic.

**Note**

The secure mode option does not appear in CTC if TCC2 cards are installed. If one TCC2 and one TCC2P card are installed in a node, secure mode will appear in CTC but it cannot be modified.

**Note**

If both front and backplane access ports are disabled in an ENE and the node is isolated from DCC communication (due to user provisioning or network faults), the front and backplane ports are automatically reenabled.

[Figure 13-16 on page 13-22](#) shows an example of secure-mode ONS 15454 nodes with front-access Ethernet port addresses that reside on the same subnet.

Figure 13-16 . IP Scenario 9: ONS 15454 GNE and ENEs on the Same Subnet with Secure Mode Enabled

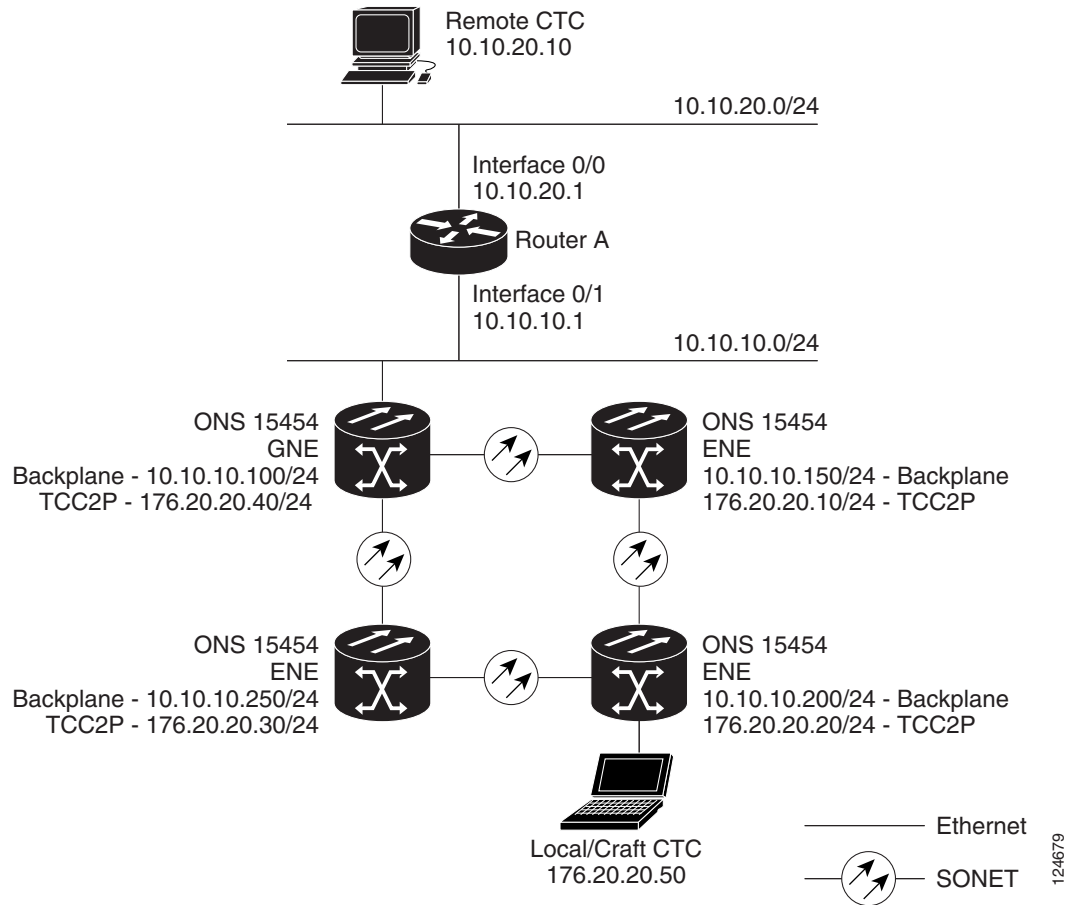
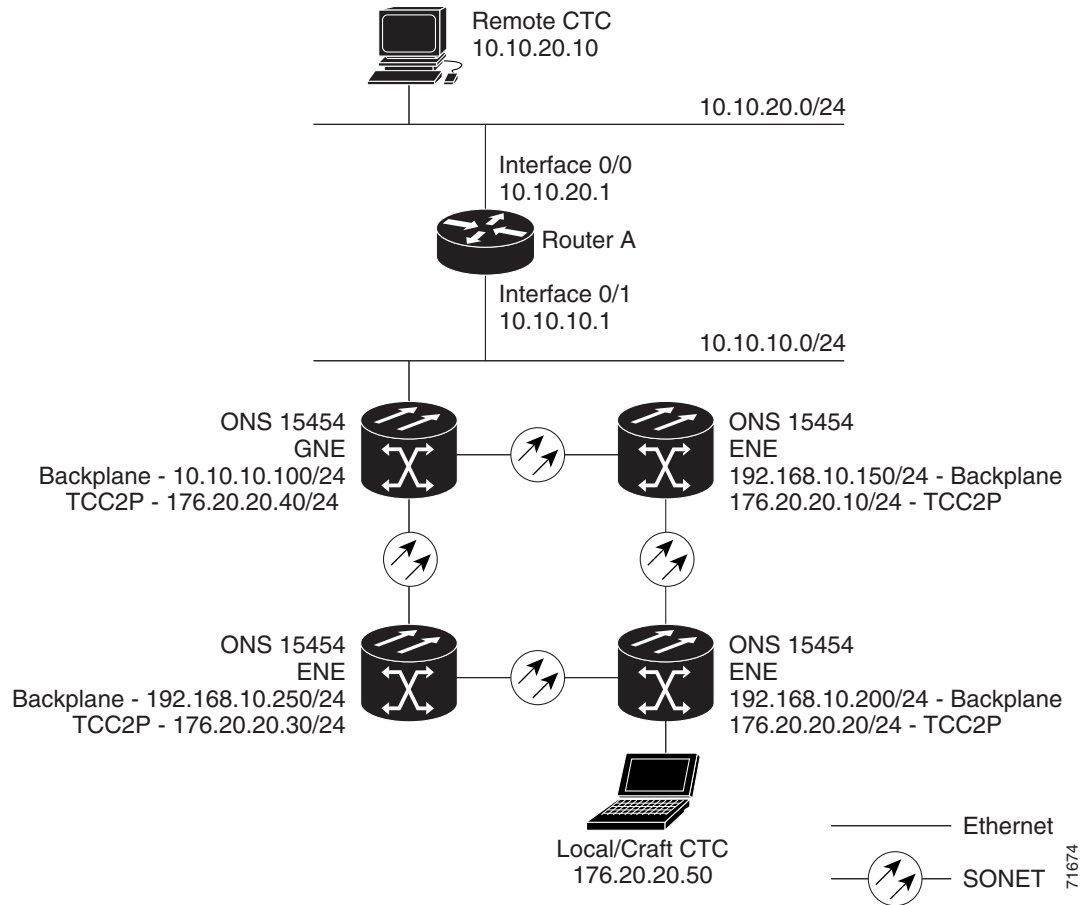

Figure 13-17 shows an example of ONS 15454 nodes connected to a router with secure mode enabled. In each example, the node's TCC2P port address (node address) resides on a different subnet from the node backplane address.

Figure 13-17 IP Scenario 9: ONS 15454 GNE and ENEs on Different Subnets with Secure Mode Enabled



13.2.9.2 Secure Node Locked and Unlocked Behavior

Secure mode can be locked or unlocked on a node operating in secure mode. The default status is unlocked, and only a Superuser can issue a lock. When secure mode is locked, the node's configuration (including Ethernet port status) and lock status cannot be changed by any network user. To have a secure node's lock removed, contact Cisco Technical Support to arrange a Return Material Authorization (RMA) for the shelf assembly. See the [“Obtaining Documentation and Submitting a Service Request” section on page 1](#) as needed. Enabling a lock makes a permanent change to the shelf's electrically erasable programmable read-only memory (EEPROM).



Note

A node's lock status in secure mode is different from external switching command locks (lock-on and lockout). For more information about port protection locks, see [Chapter 7, “Card Protection.”](#)

A node's configuration lock is maintained if the active TCC2P card's database is reloaded. For example, if you attempt to load an unlocked node database onto a locked node's standby TCC2P card for transfer to the active TCC2P card (an action that is not recommended), the unlocked node's status (through the uploaded database) will not override the node's lock status. If you attempt to load a locked database onto the standby TCC2P card of an unlocked secure node, the active TCC2P card will upload the database. If

the uploaded defaults indicate a locked status, this will cause the node to become locked. If a software load has been customized before a lock is enabled, all lockable provisioning features are permanently set to the customized NE defaults provided in the load and cannot be changed by any user.

13.3 Provisionable Patchcords

A provisionable patchcord is a user-provisioned link that is advertised by OSPF throughout the network. Provisionable patchcords, also called virtual links, are needed in the following situations:

- An optical port is connected to a transponder (TXP) or muxponder (MXP) client port provisioned in transparent mode.
- An optical ITU port is connected to a dense wavelength division multiplexing (DWDM) optical channel card.
- Two TXP or MXP trunk ports are connected to a DWDM optical channel card and the generic communications channel (GCC) is carried transparently through the ring.
- TXP or MXP client and trunk ports are in a regenerator group, the cards are in transparent mode, and DCC/GCC termination is not available.

Provisionable patchcords are required on both ends of a physical link. The provisioning at each end includes a local patchcord ID, slot/port information, remote IP address, and remote patchcord ID. Patchcords appear as dashed lines in CTC network view.

An optical patchcord must be provisioned between an OCH filter and an OCH trunk port. In A manually provisioned patchcord automatically tunes the transponder (TXP) or muxponder (MXP) trunk as an OCH filter if the TXP or MXP is set to autoprovisioning at the first tunable wavelength. You can automatically tune internal and external (virtual link) patchcords in CTC. In TL1, only internal patchcords can be provisioned.

Table 13-5 lists the supported card combinations for client and trunk ports in a provisionable patchcord.

Table 13-5 Cisco ONS 15454 Client/Trunk Card Combinations for Provisionable Patchcords

Trunk Cards	Client Cards						
	MXP_2.5G_10G/ TXP_MR_10G	TXP(P)_MR_2.5G	MXP_2.5G_10E/ TXP_MR_10E	32MUX-0 32DMX-0	32WSS/ 32DMX	AD-xC-xx.x	4MD-xx.x
MXP_2.5G_10G/ TXP_MR_10G	—	—	—	Yes	Yes	Yes	Yes
TXP(P)_MR_2.5G	—	—	—	Yes	Yes	Yes	Yes
MXP_2.5G_10E/ TXP_MR_10E	—	—	—	Yes	Yes	Yes	Yes
MXP(P)_MR_2.5G	—	—	—	Yes	Yes	Yes	Yes
OC-192	Yes	—	Yes	—	—	—	—
OC-48	Yes	Yes	Yes	—	—	—	—
OC-192 ITU	—	—	—	Yes	Yes	Yes	Yes
OC-48 ITU	—	—	—	Yes	Yes	Yes	Yes

**Note**

If the OCSM card is installed in Slot 8, provisionable patchcords from OC-N ports to the following cards are not supported on the same node: MXP_2.5G_10G, TXP_MR_10G, TXP(P)_MR_2.5G, MXP_2.5G_10E, TXP_MR_10E, 32MUX-O, 32DMX-O, 32WSS, and 32DMX.

Table 13-6 lists the supported card combinations for client-to-client ports in a patchcord.

Table 13-6 Cisco ONS 15454 Client/Client Card Combinations for Provisionable Patchcords

Client Cards	MXP_2.5G_10G/ TXP_MR_10G	TXP(P)_MR_2.5G	MXP_2.5G_10E/ TXP_MR_10E
MXP_2.5G_10G/ TXP_MR_10G	Yes	—	Yes
TXP(P)_MR_2.5G	—	Yes	—
MXP_2.5G_10E/ TXP_MR_10E	Yes	—	Yes

Table 13-7 lists the supported card combinations for trunk-to-trunk ports in a patchcord.

Table 13-7 Cisco ONS 15454 Trunk/Trunk Card Combinations for Provisionable Patchcords

Trunk Cards	MXP_2.5G_10G/ TXP_MR_10G	TXP(P)_MR_2.5G	MXP_2.5G_10E/ TXP_MR_10E
MXP_2.5G_10G/ TXP_MR_10G	Yes	—	Yes
TXP(P)_MR_2.5G	—	Yes	—
MXP_2.5G_10E/ TXP_MR_10E	Yes	—	Yes

Optical ports have the following requirements when used in a provisionable patchcord:

- An optical port connected to a TXP/MXP port, add/drop multiplexer port, or multiplexer/demultiplexer port requires a Section DCC/Line DCC (SDCC/LDCC) termination.
- If the optical port is the protection port in a 1+1 group, the working port must have an SDCC/LDCC termination provisioned.
- If the remote end of a patchcord is Y-cable protected or is an add/drop multiplexer or multiplexer/demultiplexer port, an optical port requires two patchcords.

TXP and MXP ports have the following requirements when used in a provisionable patchcord:

- Two patchcords are required when a TXP/MXP port is connected to an add/drop multiplexer or multiplexer/demultiplexer port. CTC automatically prompts the user to set up the second patchcord.
- If a patchcord is on a client port in a regenerator group, the other end of the patchcord must be on the same node and on a port within the same regenerator group.
- A patchcord is allowed on a client port only if the card is in transparent mode.

DWDM cards support provisionable patchcords only on optical channel ports. Each DWDM optical channel port can have only one provisionable patchcord.

**Note**

For TXP, MXP, and DWDM card information, refer to the *Cisco ONS 15454 DWDM Reference Manual*.

13.4 Routing Table

ONS 15454 routing information appears on the Maintenance > Routing Table tab. The routing table provides the following information:

- Destination—Displays the IP address of the destination network or host.
- Mask—Displays the subnet mask used to reach the destination host or network.
- Gateway—Displays the IP address of the gateway used to reach the destination network or host.
- Usage—Shows the number of times the listed route has been used.
- Interface—Shows the ONS 15454 interface used to access the destination. Values are:
 - motfcc0—The ONS 15454 Ethernet interface, that is, the RJ-45 jack on the TCC2/TCC2P and the LAN 1 pins on the backplane
 - pdcc0—A DCC/OSC/GCC interface
 - lo0—A loopback interface

Table 13-8 shows sample routing table entries for an ONS 15454.

Table 13-8 Sample Routing Table Entries

Entry	Destination	Mask	Gateway	Usage	Interface
1	0.0.0.0	0.0.0.0	172.20.214.1	265103	motfcc0
2	172.20.214.0	255.255.255.0	172.20.214.92	0	motfcc0
3	172.20.214.92	255.255.255.255	127.0.0.1	54	lo0
4	172.20.214.93	255.255.255.255	0.0.0.0	16853	pdcc0
5	172.20.214.94	255.255.255.255	172.20.214.93	16853	pdcc0

Entry 1 shows the following:

- Destination (0.0.0.0) is the default route entry. All undefined destination network or host entries on this routing table are mapped to the default route entry.
- Mask (0.0.0.0) is always 0 for the default route.
- Gateway (172.20.214.1) is the default gateway address. All outbound traffic that cannot be found in this routing table or is not on the node's local subnet is sent to this gateway.
- Interface (motfcc0) indicates that the ONS 15454 Ethernet interface is used to reach the gateway.

Entry 2 shows the following:

- Destination (172.20.214.0) is the destination network IP address.
- Mask (255.255.255.0) is a 24-bit mask, meaning all addresses within the 172.20.214.0 subnet can be destinations.
- Gateway (172.20.214.92) is the gateway address. All outbound traffic belonging to this network is sent to this gateway.
- Interface (motfcc0) indicates that the ONS 15454 Ethernet interface is used to reach the gateway.

Entry 3 shows the following:

- Destination (172.20.214.92) is the destination host IP address.
- Mask (255.255.255.255) is a 32 bit mask, meaning that only the 172.20.214.92 address is a destination.
- Gateway (127.0.0.1) is a loopback address. The host directs network traffic to itself using this address.
- Interface (lo0) indicates that the local loopback interface is used to reach the gateway.

Entry 4 shows the following:

- Destination (172.20.214.93) is the destination host IP address.
- Mask (255.255.255.255) is a 32 bit mask, meaning that only the 172.20.214.93 address is a destination.
- Gateway (0.0.0.0) means the destination host is directly attached to the node.
- Interface (pdcc0) indicates that a DCC interface is used to reach the destination host.

Entry 5 shows a DCC-connected node that is accessible through a node that is not directly connected:

- Destination (172.20.214.94) is the destination host IP address.
- Mask (255.255.255.255) is a 32-bit mask, meaning that only the 172.20.214.94 address is a destination.
- Gateway (172.20.214.93) indicates that the destination host is accessed through a node with IP address 172.20.214.93.
- Interface (pdcc0) indicates that a DCC interface is used to reach the gateway.

13.5 External Firewalls

This section provides sample access control lists (ACLs) for external firewalls. [Table 13-9](#) lists the ports that are used by the TCC2/TCC2P card.

Table 13-9 Ports Used by the TCC2/TCC2P

Port	Function	Action ¹
0	Never used	D
20	FTP	D
21	FTP control	D
22	SSH (Secure Shell)	D
23	Telnet	D
80	HTTP	D
111	SUNRPC (Sun Remote Procedure Call)	NA
161	SNMP traps destinations	D
162	SNMP traps destinations	D
513	rlogin	D
683	CORBA IIOP ²	OK
1080	Proxy server (socks)	D

Table 13-9 Ports Used by the TCC2/TCC2P (continued)

Port	Function	Action ¹
2001-2017	I/O card Telnet	D
2018	DCC processor on active TCC2/TCC2P	D
2361	TL1	D
3082	Raw TL1	D
3083	TL1	D
5001	BLSR ³ server port	D
5002	BLSR client port	D
7200	SNMP alarm input port	D
9100	EQM port	D
9401	TCC boot port	D
9999	Flash manager	D
10240-12287	Proxy client	D
57790	Default TCC listener port	OK

1. D = deny, NA = not applicable, OK = do not deny
2. CORBA IIOP = Common Object Request Broker Architecture Internet Inter-ORB Protocol
3. BLSR = bidirectional line switched ring

The following ACL example shows a firewall configuration when the SOCKS proxy server gateway setting is not enabled. In the example, the CTC workstation's address is 192.168.10.10, and the ONS 15454 address is 10.10.10.100. The firewall is attached to the GNE, so inbound is CTC to the GNE and outbound is from the GNE to CTC. The CTC CORBA Standard constant is 683 and the TCC CORBA Default is TCC Fixed (57790).

```
access-list 100 remark *** Inbound ACL, CTC -> NE ***
access-list 100 remark
access-list 100 permit tcp host 192.168.10.10 host 10.10.10.100 eq www
access-list 100 remark *** allows initial contact with ONS 15454 using http (port 80) ***
access-list 100 remark
access-list 100 permit tcp host 192.168.10.10 host 10.10.10.100 eq 57790
access-list 100 remark *** allows CTC communication with ONS 15454 GNE (port 57790) ***
access-list 100 remark
access-list 100 permit tcp host 192.168.10.10 host 10.10.10.100 established
access-list 100 remark *** allows ACKs back from CTC to ONS 15454 GNE ***

access-list 101 remark *** Outbound ACL, NE -> CTC ***
access-list 101 remark
access-list 101 permit tcp host 10.10.10.100 host 192.168.10.10 eq 683
access-list 101 remark *** allows alarms etc., from the 15454 (random port) to the CTC
workstation (port 683) ***
access-list 100 remark
access-list 101 permit tcp host 10.10.10.100 host 192.168.10.10 established
access-list 101 remark *** allows ACKs from the 15454 GNE to CTC ***
```

The following ACL example shows a firewall configuration when the SOCKS proxy server gateway setting is enabled. As with the first example, the CTC workstation address is 192.168.10.10 and the ONS 15454 address is 10.10.10.100. The firewall is attached to the GNE, so inbound is CTC to the GNE and outbound is from the GNE to CTC. CTC CORBA Standard constant is 683 and the TCC CORBA Default is TCC Fixed (57790).

```
access-list 100 remark *** Inbound ACL, CTC -> NE ***
access-list 100 remark
access-list 100 permit tcp host 192.168.10.10 host 10.10.10.100 eq www
access-list 100 remark *** allows initial contact with the 15454 using http (port 80) ***
access-list 100 remark
access-list 100 permit tcp host 192.168.10.10 host 10.10.10.100 eq 1080
access-list 100 remark *** allows CTC communication with the 15454 GNE (port 1080) ***
access-list 100 remark

access-list 101 remark *** Outbound ACL, NE -> CTC ***
access-list 101 remark
access-list 101 permit tcp host 10.10.10.100 host 192.168.10.10 established
access-list 101 remark *** allows ACKs from the 15454 GNE to CTC ***
```

13.6 Open GNE

The ONS 15454 can communicate with non-ONS nodes that do not support Point-to-Point Protocol (PPP) vendor extensions or OSPF type 10 opaque link-state advertisements (LSA), both of which are necessary for automatic node and link discovery. An open GNE configuration allows the DCC-based network to function as an IP network for non-ONS nodes.

To configure an open GNE network, you can provision SDCC, LDCC, and GCC terminations to include a far-end, non-ONS node using either the default IP address of 0.0.0.0 or a specified IP address. You provision a far-end, non-ONS node by checking the Far End is Foreign check box during SDCC, LDCC, and GCC creation. The default 0.0.0.0 IP address allows the far-end, non-ONS node to provide the IP address; if you set an IP address other than 0.0.0.0, a link is established only if the far-end node identifies itself with that IP address, providing an extra level of security.

By default, the SOCKS proxy server only allows connections to discovered ONS peers and the firewall blocks all IP traffic between the DCC network and LAN. You can, however, provision proxy tunnels to allow up to 12 additional destinations for SOCKS version 5 connections to non-ONS nodes. You can also provision firewall tunnels to allow up to 12 additional destinations for direct IP connectivity between the DCC network and the LAN. Proxy and firewall tunnels include both a source and destination subnet. The connection must originate within the source subnet and terminate within the destination subnet before either the SOCKS connection or IP packet flow is allowed.

To set up proxy and firewall subnets in CTC, use the Provisioning > Network > Proxy and Firewalls subtabs. The availability of proxy and/or firewall tunnels depends on the network access settings of the node:

- If the node is configured with the SOCKS proxy server enabled in GNE or ENE mode, you must set up a proxy tunnel and/or a firewall tunnel.
- If the node is configured with the SOCKS proxy server enabled in proxy-only mode, you can set up proxy tunnels. Firewall tunnels are not allowed.
- If the node is configured with the SOCKS proxy server disabled, neither proxy tunnels nor firewall tunnels are allowed.

Figure 13-18 shows an example of a foreign node connected to the DCC network. Proxy and firewall tunnels are useful in this example because the GNE would otherwise block IP access between the PC and the foreign node.

Figure 13-18 Proxy and Firewall Tunnels for Foreign Terminations

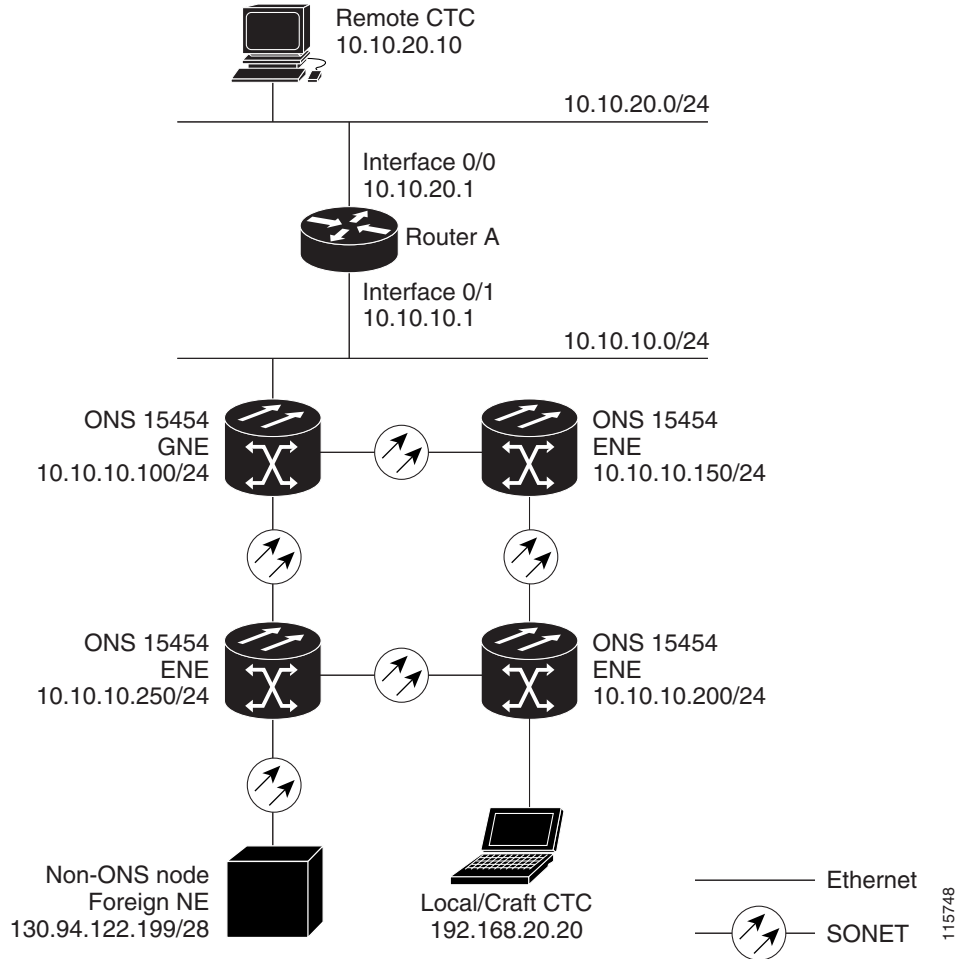
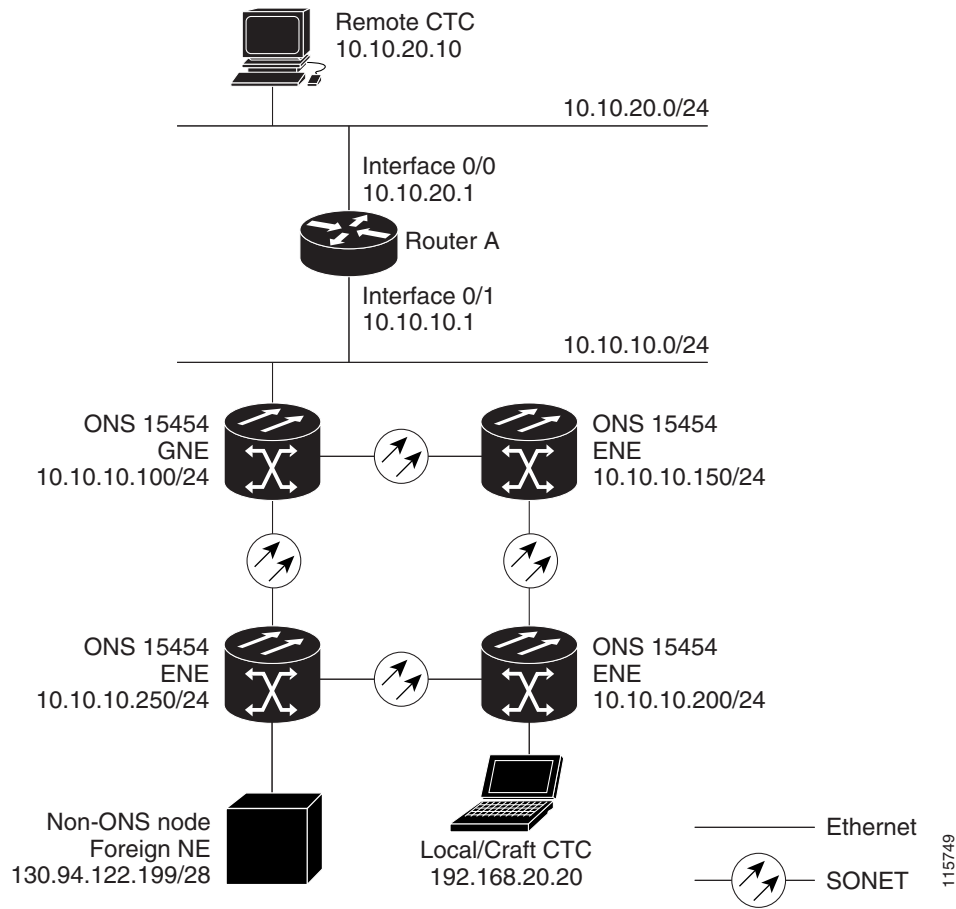

Figure 13-19 shows a remote node connected to an ENE Ethernet port. Proxy and firewall tunnels are useful in this example because the GNE would otherwise block IP access between the PC and foreign node. This configuration also requires a firewall tunnel on the ENE.

Figure 13-19 Foreign Node Connection to an ENE Ethernet Port



13.7 TCP/IP and OSI Networking

ONS 15454 DCN communication is based on the TCP/IP protocol suite. However, ONS 15454s can also be networked with equipment that uses the OSI protocol suite. While TCP/IP and OSI protocols are not directly compatible, they do have the same objectives and occupy similar layers of the OSI reference model. [Table 13-10](#) shows the protocols and mediation processes that are involved when TCP/IP-based NEs are networked with OSI-based NEs.

Table 13-10 TCP/IP and OSI Protocols

OSI Model	IP Protocols	OSI Protocols	IP-OSI Mediation	
Layer 7 Application	<ul style="list-style-type: none"> • TL1 • FTP • HTTP • Telnet • IIOP 	<ul style="list-style-type: none"> • TARP¹ 	<ul style="list-style-type: none"> • TL1 (over OSI) • FTAM² • ACSE³ 	
Layer 6 Presentation				<ul style="list-style-type: none"> • PST⁶
Layer 5 Session				<ul style="list-style-type: none"> • Session
Layer 4 Transport	<ul style="list-style-type: none"> • TCP • UDP 	<ul style="list-style-type: none"> • TP (Transport) Class 4 	<ul style="list-style-type: none"> • IP-over-CLNS⁷ tunnels 	
Layer 3 Network	<ul style="list-style-type: none"> • IP • OSPF 			
Layer 2 Data link	<ul style="list-style-type: none"> • PPP 			
Layer 1 Physical	DCC, LAN, fiber, electrical	DCC, LAN, fiber, electrical		

1. TARP = TID Address Resolution Protocol
2. FTAM = File Transfer and Access Management
3. ACSE = association-control service element
4. T-TD = TL1-Translation Device
5. FT-TD = File Transfer-Translation Device
6. PST = Presentation layer
7. CLNS = Connectionless Network Layer Service
8. CLNP = Connectionless Network Layer Protocol
9. ES-IS = End System-to-Intermediate System
10. IS-IS = Intermediate System-to-Intermediate System
11. LAP-D = Link Access Protocol on the D Channel

13.7.1 Point-to-Point Protocol

PPP is a data link (Layer 2) encapsulation protocol that transports datagrams over point-to-point links. Although PPP was developed to transport IP traffic, it can carry other protocols including the OSI CLNP. PPP components used in the transport of OSI include:

- High-level data link control (HDLC)—Performs the datagram encapsulation for transport across point-to-point links.
- Link control protocol (LCP)—Establishes, configures, and tests the point-to-point connections.

CTC automatically enables IP over PPP whenever you create an SDCC or LDCC. The SDCC or LDCC can be provisioned to support OSI over PPP.

13.7.2 Link Access Protocol on the D Channel

LAP-D is a data link protocol used in the OSI protocol stack. LAP-D is assigned when you provision an ONS 15454 SDCC as OSI-only. Provisionable LAP-D parameters include:

- Transfer Service—One of the following transfer services must be assigned:
 - Acknowledged Information Transfer Service (AITS)—(Default) Does not exchange data until a logical connection between two LAP-D users is established. This service provides reliable data transfer, flow control, and error control mechanisms.
 - Unacknowledged Information Transfer Service (UITS)—Transfers frames containing user data with no acknowledgement. The service does not guarantee that the data presented by one user will be delivered to another user, nor does it inform the user if the delivery attempt fails. It does not provide any flow control or error control mechanisms.
- Mode—LAP-D is set to either Network or User mode. This parameter sets the LAP-D frame command/response (C/R) value, which indicates whether the frame is a command or a response.
- Maximum transmission unit (MTU)—The LAP-D N201 parameter sets the maximum number of octets in a LAP-D information frame. The range is 512 to 1500 octets.



Note The MTU must be the same size for all NEs on the network.

- Transmission Timers—The following LAP-D timers can be provisioned:
 - The T200 timer sets the timeout period for initiating retries or declaring failures.
 - The T203 timer provisions the maximum time between frame exchanges, that is, the trigger for transmission of the LAP-D “keep-alive” Receive Ready (RR) frames.

Fixed values are assigned to the following LAP-D parameters:

- Terminal Endpoint Identifier (TEI)—A fixed value of 0 is assigned.
- Service Access Point Identifier (SAPI)—A fixed value of 62 is assigned.
- N200 supervisory frame retransmissions—A fixed value of 3 is assigned.

13.7.3 OSI Connectionless Network Service

OSI connectionless network service is implemented by using the Connectionless Network Protocol (CLNP) and Connectionless Network Service (CLNS). CLNP and CLNS are described in the ISO 8473 standard. CLNS provides network layer services to the transport layer through CLNP. CLNS does not perform connection setup or termination because paths are determined independently for each packet that is transmitted through a network. CLNS relies on transport layer protocols to perform error detection and correction.

CLNP is an OSI network layer protocol that carries upper-layer data and error indications over connectionless links. CLNP provides the interface between the CLNS and upper layers. CLNP performs many of the same services for the transport layer as IP. The CLNP datagram is very similar to the IP datagram. It provides mechanisms for fragmentation (data unit identification, fragment/total length, and offset). Like IP, a checksum computed on the CLNP header verifies that the information used to process the CLNP datagram is transmitted correctly, and a lifetime control mechanism (Time to Live) limits the amount of time a datagram is allowed to remain in the system.

CLNP uses network service access points (NSAPs) to identify network devices. The CLNP source and destination addresses are NSAPs. In addition, CLNP uses a network element title (NET) to identify a network-entity in an end system (ES) or intermediate system (IS). NETs are allocated from the same name space as NSAP addresses. Whether an address is an NSAP address or a NET depends on the network selector value in the NSAP.

The ONS 15454 supports the ISO Data Country Code (ISO-DCC) NSAP address format as specified in ISO 8348. The NSAP address is divided into an initial domain part (IDP) and a domain-specific part (DSP). NSAP fields are shown in Table 13-11. NSAP field values are in hexadecimal format. All NSAPs are editable. Shorter NSAPs can be used. However NSAPs for all NEs residing within the same OSI network area usually have the same NSAP format.

Table 13-11 NSAP Fields

Field	Definition	Description
IDP		
AFI	Authority and format identifier	Specifies the NSAP address format. The initial value is 39 for the ISO-DCC address format.
IDI	Initial domain identifier	Specifies the country code. The initial value is 840F, the United States country code padded with an F.
DSP		
DFI	DSP format identifier	Specifies the DSP format. The initial value is 80, indicating the DSP format follows American National Standards Institute (ANSI) standards.
ORG	Organization	Organization identifier. The initial value is 000000.
Reserved	Reserved	Reserved NSAP field. The Reserved field is normally all zeros (0000).
RD	Routing domain	Defines the routing domain. The initial value is 0000.
AREA	Area	Identifies the OSI routing area to which the node belongs. The initial value is 0000.

Table 13-11 NSAP Fields (continued)

Field	Definition	Description
System	System identifier	The ONS 15454 system identifier is set to its IEEE 802.3 MAC address. Each ONS 15454 supports three OSI virtual routers. Each router NSAP system identifier is the ONS 15454 IEEE 802.3 MAC address + <i>n</i> , where <i>n</i> = 0 to 2. For the primary virtual router, <i>n</i> = 0.
SEL	Selector	<p>The selector field directs the protocol data units (PDUs) to the correct destination using the CLNP network layer service. Selector values supported by the ONS 15454 include:</p> <ul style="list-style-type: none"> • 00—Network Entity Title (NET). Used to exchange PDUs in the ES-IS and IS-IS routing exchange protocols. (See the “13.7.4.1 End System-to-Intermediate System Protocol” section on page 13-38 and the “13.7.4.2 Intermediate System-to-Intermediate System Protocol” section on page 13-38.) • 1D—Selector for Transport Class 4 (and for FTAM and TL1 applications (Telcordia GR-253-CORE standard) • AF—Selector for the TARP protocol (Telcordia GR-253-CORE standard) • 2F—Selector for the GRE IP-over-CLNS tunnel (ITU/RFC standard) • CC—Selector for the Cisco IP-over-CLNS tunnels (Cisco specific) • E0—Selector for the OSI ping application (Cisco specific) <p>NSELS are only advertised when the node is configured as an ES. They are not advertised when a node is configured as an IS. Tunnel NSELS are not advertised until a tunnel is created.</p>

Figure 13-20 shows the ISO-DCC NSAP address with the default values delivered with the ONS 15454. The System ID is automatically populated with the node MAC address.

Figure 13-20 ISO-DCC NSAP Address

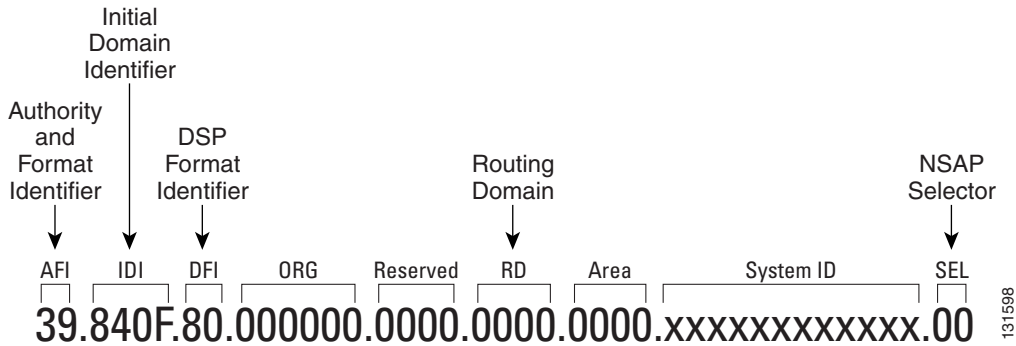

The ONS 15454 main NSAP address is shown on the node view Provisioning > OSI > Main Setup subtab (Figure 13-21).

Figure 13-21 OSI Main Setup

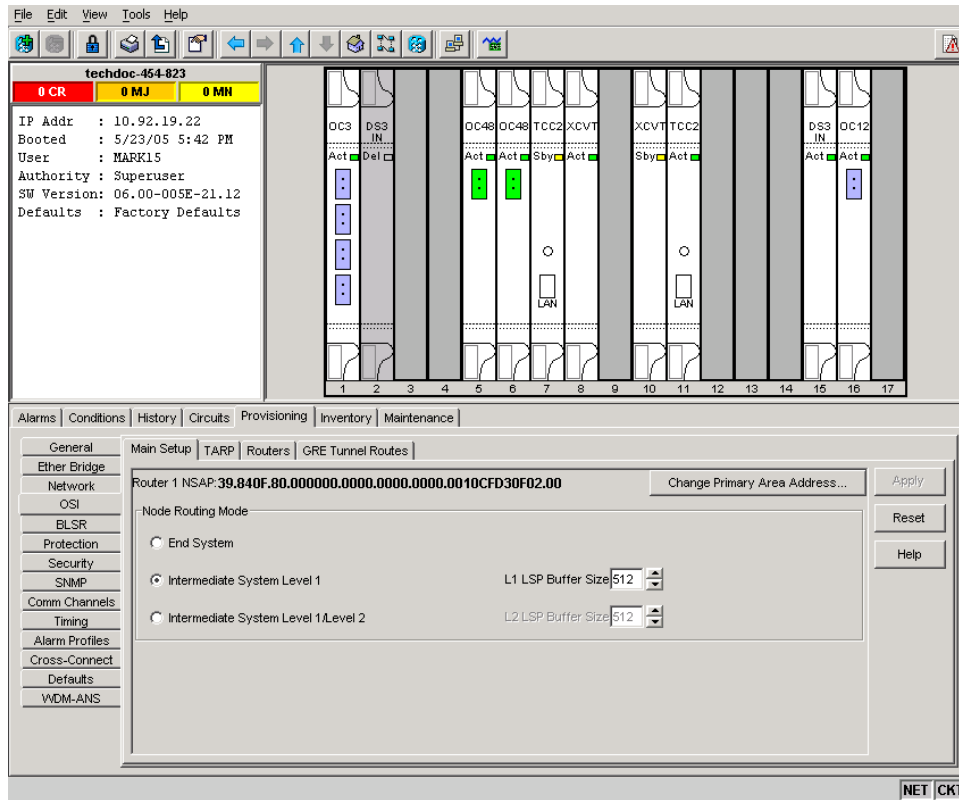

This address is also the Router 1 primary manual area address, which is viewed and edited on the Provisioning > OSI > Routers subtab. See the “13.7.7 OSI Virtual Routers” section on page 13-43 for information about the OSI router and manual area addresses in CTC.

13.7.4 OSI Routing

OSI architecture includes ESs and ISs. The OSI routing scheme includes:

- A set of routing protocols that allow ESs and ISs to collect and distribute the information necessary to determine routes. Protocols include the ES-IS and IS-IS protocols. ES-IS routing establishes connectivity and reach ability among ESs and ISs attached to the same (single) subnetwork.
- A routing information base (RIB) (see containing this information, from which routes between ESs can be computed. The RIB consists of a table of entries that identify a destination (for example, an NSAP), the subnetwork over which packets should be forwarded to reach that destination, and a routing metric. The routing metric communicates characteristics of the route (such as delay properties or expected error rate) that are used to evaluate the suitability of a route compared to another route with different properties, for transporting a particular packet or class of packets.
- A routing algorithm, Shortest Path First (SPF), that uses information contained in the RIB to derive routes between ESs.

In OSI networking, discovery is based on announcements. An ES uses the ES-IS protocol end system hello (ESH) message to announce its presence to ISs and ESs connected to the same network. Any ES or IS that is listening for ESHs gets a copy. ISs store the NSAP address and the corresponding subnetwork address pair in routing tables. ESs might store the address, or they might wait to be informed by ISs when they need such information.

An IS composes intermediate system hello (ISH) messages to announce its configuration information to ISs and ESs that are connected to the same broadcast subnetwork. Like the ESHs, the ISH contains the addressing information for the IS (the NET and the subnetwork point-of-attachment address [SNPA]) and a holding time. ISHs might also communicate a suggested ES configuration time recommending a configuration timer to ESs.

The exchange of ISHs is called neighbor greeting or initialization. Each router learns about the other routers with which they share direct connectivity. After the initialization, each router constructs a link-state packet (LSP). The LSP contains a list of the names of the IS's neighbors and the cost to reach each of the neighbors. Routers then distribute the LSPs to all of the other routers. When all LSPs are propagated to all routers, each router has a complete map of the network topology (in the form of LSPs). Routers use the LSPs and the SPF algorithm to compute routes to every destination in the network.

OSI networks are divided into areas and domains. An area is a group of contiguous networks and attached hosts that is designated as an area by a network administrator. A domain is a collection of connected areas. Routing domains provide full connectivity to all ESs within them. Routing within the same area is known as Level 1 routing. Routing between two areas is known as Level 2 routing. LSPs that are exchanged within a Level 1 area are called L1 LSPs. LSPs that are exchanged across Level 2 areas are called L2 LSPs. [Figure 13-22](#) shows an example of Level 1 and Level 2 routing.

Figure 13-22 Level 1 and Level 2 OSI Routing

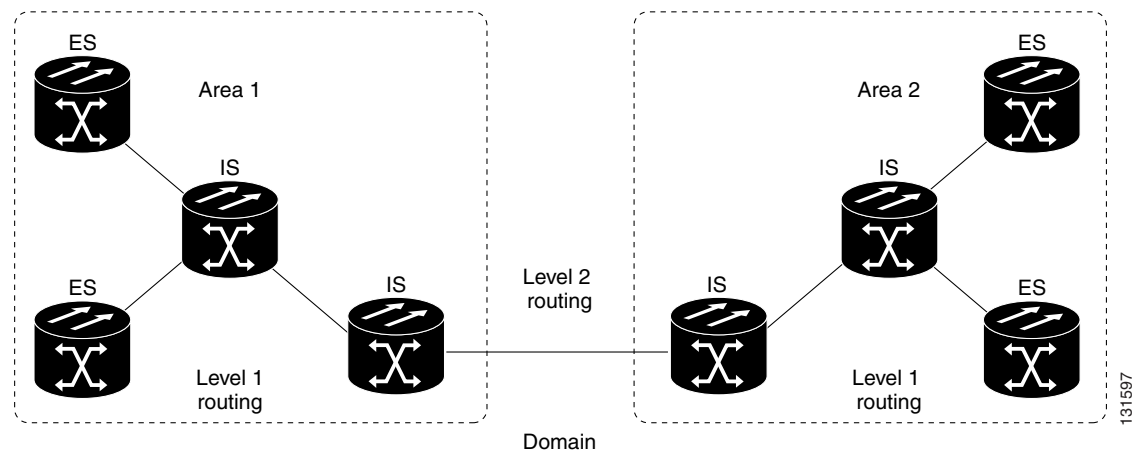

When you provision an ONS 15454 for a network with NEs that use both the TCP/IP and OSI protocol stacks, you will provision it as one of the following:

- End System—The ONS 15454 performs OSI ES functions and relies upon an IS for communication with nodes that reside within its OSI area.
- Intermediate System Level 1—The ONS 15454 performs OSI IS functions. It communicates with IS and ES nodes that reside within its OSI area. It depends upon an IS L1/L2 node to communicate with IS and ES nodes that reside outside its OSI area.

- Intermediate System Level 1/Level 2—The ONS 15454 performs IS functions. It communicates with IS and ES nodes that reside within its OSI area. It also communicates with IS L1/L2 nodes that reside in other OSI areas. This option should not be provisioned unless the node is connected to another IS L1/L2 node that resides in a different OSI area. The node must also be connected to all nodes within its area that are provisioned as IS L1/L2.

13.7.4.1 End System-to-Intermediate System Protocol

ES-IS is an OSI protocol that defines how ESs (hosts) and ISs (routers) learn about each other. ES-IS configuration information is transmitted at regular intervals through the ES and IS hello messages. The hello messages contain the subnetwork and network layer addresses of the systems that generate them.

The ES-IS configuration protocol communicates both OSI network layer addresses and OSI subnetwork addresses. OSI network layer addresses identify either the NSAP, which is the interface between OSI Layer 3 and Layer 4, or the NET, which is the network layer entity in an OSI IS. OSI SNPAs are the points at which an ES or IS is physically attached to a subnetwork. The SNPA address uniquely identifies each system attached to the subnetwork. In an Ethernet network, for example, the SNPA is the 48-bit MAC address. Part of the configuration information transmitted by ES-IS is the NSAP-to-SNPA or NET-to-SNPA mapping.

13.7.4.2 Intermediate System-to-Intermediate System Protocol

IS-IS is an OSI link-state hierarchical routing protocol that floods the network with link-state information to build a complete, consistent picture of a network topology. IS-IS distinguishes between Level 1 and Level 2 ISs. Level 1 ISs communicate with other Level 1 ISs in the same area. Level 2 ISs route between Level 1 areas and form an intradomain routing backbone. Level 1 ISs need to know only how to get to the nearest Level 2 IS. The backbone routing protocol can change without impacting the intra-area routing protocol.

OSI routing begins when the ESs discover the nearest IS by listening to ISH packets. When an ES wants to send a packet to another ES, it sends the packet to one of the ISs on its directly attached network. The router then looks up the destination address and forwards the packet along the best route. If the destination ES is on the same subnetwork, the local IS knows this from listening to ESHs and forwards the packet appropriately. The IS also might provide a redirect (RD) message back to the source to tell it that a more direct route is available. If the destination address is an ES on another subnetwork in the same area, the IS knows the correct route and forwards the packet appropriately. If the destination address is an ES in another area, the Level 1 IS sends the packet to the nearest Level 2 IS. Forwarding through Level 2 ISs continues until the packet reaches a Level 2 IS in the destination area. Within the destination area, the ISs forward the packet along the best path until the destination ES is reached.

Link-state update messages help ISs learn about the network topology. Each IS generates an update specifying the ESs and ISs to which it is connected, as well as the associated metrics. The update is then sent to all neighboring ISs, which forward (flood) it to their neighbors, and so on. (Sequence numbers terminate the flood and distinguish old updates from new ones.) Using these updates, each IS can build a complete topology of the network. When the topology changes, new updates are sent.

IS-IS uses a single required default metric with a maximum path value of 1024. The metric is arbitrary and typically is assigned by a network administrator. Any single link can have a maximum value of 64, and path links are calculated by summing link values. Maximum metric values were set at these levels to provide the granularity to support various link types while at the same time ensuring that the shortest-path algorithm used for route computation is reasonably efficient. Three optional IS-IS metrics (costs)—delay, expense, and error—are not supported by the ONS 15454. IS-IS maintains a mapping of the metrics to the quality of service (QoS) option in the CLNP packet header. IS-IS uses the mappings to compute routes through the internetwork.

13.7.5 TARP

TARP is used when TL1 target identifiers (TIDs) must be translated to NSAP addresses. The TID-to-NSAP translation occurs by mapping TIDs to the NETs, then deriving NSAPs from the NETs by using the NSAP selector values (Table 13-11 on page 13-34).

TARP uses a selective PDU propagation methodology in conjunction with a distributed database (that resides within the NEs) of TID-to-NET mappings. TARP allows NEs to translate between TID and NET by automatically exchanging mapping information with other NEs. The TARP PDU is carried by the standard CLNP Data PDU. TARP PDU fields are shown in Table 13-12.

Table 13-12 TARP PDU Fields

Field	Abbreviation	Size (bytes)	Description
TARP Lifetime	tar-lif	2	The TARP time-to-live in hops.
TARP Sequence Number	tar-seq	2	The TARP sequence number used for loop detection.
Protocol Address Type	tar-pro	1	Used to identify the type of protocol address that the TID must be mapped to. The value FE is used to identify the CLNP address type.
TARP Type Code	tar-tcd	1	The TARP Type Code identifies the TARP type of PDU. Five TARP types, shown in Table 13-13, are defined.
TID Target Length	tar-tln	1	The number of octets that are in the tar-ttg field.
TID Originator Length	tar-oln	1	The number of octets that are in the tar-tor field.
Protocol Address Length	tar-pln	1	The number of octets that are in the tar-por field.
TID of Target	tar-ttg	$n = 0, 1, 2...$	TID value for the target NE.
TID of Originator	tar-tor	$n = 0, 1, 2...$	TID value of the TARP PDU originator.
Protocol Address of Originator	tar-por	$n = 0, 1, 2...$	Protocol address (for the protocol type identified in the tar-pro field) of the TARP PDU originator. When the tar-pro field is set to FE (hex), tar-por will contain a CLNP address (that is, the NET).

Table 13-13 shows the TARP PDUs types that govern TARP interaction and routing.

Table 13-13 TARP PDU Types

Type	Description	Actions
1	Sent when a device has a TID for which it has no matching NSAP.	After an NE originates a TARP Type 1 PDU, the PDU is sent to all adjacent NEs within the NE routing area.
2	Sent when a device has a TID for which it has no matching NSAP and no response was received from the Type 1 PDU.	After an NE originates a TARP Type 2 PDU, the PDU is sent to all Level 1 and Level 2 neighbors.

Table 13-13 TARP PDU Types (continued)

Type	Description	Actions
3	Sent as a response to Type 1, Type 2, or Type 5 PDUs.	After a TARP Request (Type 1 or 2) PDU is received, a TARP Type 3 PDU is sent to the request originator. Type 3 PDUs do not use the TARP propagation procedures.
4	Sent as a notification when a change occurs locally, for example, a TID or NSAP change. It might also be sent when an NE initializes.	A Type 4 PDU is a notification of a TID or Protocol Address change at the NE that originates the notification. The PDU is sent to all adjacencies inside and outside the NE's routing area.
5	Sent when a device needs a TID that corresponds to a specific NSAP.	When a Type 5 PDU is sent, the CLNP destination address is known, so the PDU is sent to only that address. Type 5 PDUs do not use the TARP propagation procedures.

13.7.5.1 TARP Processing

A TARP data cache (TDC) is created at each NE to facilitate TARP processing. In CTC, the TDC is displayed and managed on the node view Maintenance > OSI > TDC subtab. The TDC subtab contains the following TARP PDU fields:

- TID—TID of the originating NE (tar-tor).
- NSAP—NSAP of the originating NE.
- Type— Indicates whether the TARP PDU was created through the TARP propagation process (dynamic) or manually created (static).

Provisionable timers, shown in [Table 13-14](#), control TARP processing.

Table 13-14 TARP Timers

Timer	Description	Default (seconds)	Range (seconds)
T1	Waiting for response to TARP Type 1 Request PDU	15	0–3600
T2	Waiting for response to TARP Type 2 Request PDU	25	0–3600
T3	Waiting for response to address resolution request	40	0–3600
T4	Timer starts when T2 expires (used during error recovery)	20	0–3600

[Table 13-15](#) shows the main TARP processes and the general sequence of events that occurs in each process.

Table 13-15 TARP Processing Flow

Process	General TARP Flow
Find a NET that matches a TID	<ol style="list-style-type: none"> 1. TARP checks its TDC for a match. If a match is found, TARP returns the result to the requesting application. 2. If no match is found, a TARP Type 1 PDU is generated and Timer T1 is started. 3. If Timer T1 expires before a match is found, a Type 2 PDU is generated and Timer T2 is started. 4. If Timer T2 expires before a match is found, Timer T4 is started. 5. If Timer T4 expires before a match is found, a Type 2 PDU is generated and Timer T2 is started.
Find a TID that matches a NET	A Type 5 PDU is generated. Timer T3 is used. However, if the timer expires, no error recovery procedure occurs, and a status message is provided to indicate that the TID cannot be found.
Send a notification of TID or protocol address change	TARP generates a Type 4 PDU in which the tar-ttg field contains the NE TID value that existed prior to the change of TID or protocol address. Confirmation that other NEs successfully received the address change is not sent.

13.7.5.2 TARP Loop Detection Buffer

The TARP loop detection buffer (LDB) can be enabled to prevent duplicate TARP PDUs from entering the TDC. When a TARP Type 1, 2, or 4 PDU arrives, TARP checks its LDB for a NET address (tar-por) of the PDU originator match. If no match is found, TARP processes the PDU and assigns a tar-por, tar-seq (sequence) entry for the PDU to the LDB. If the tar-seq is zero, a timer associated with the LDB entry is started using the provisionable LDB entry timer on the node view `OSI > TARP > Config` tab. If a match exists, the tar-seq is compared to the LDB entry. If the tar-seq is not zero and is less than or equal to the LDB entry, the PDU is discarded. If the tar-seq is greater than the LDB entry, the PDU is processed and the tar-seq field in the LDB entry is updated with the new value. The Cisco ONS 15454 LDB holds approximately 500 entries. The LDB is flushed periodically based on the time set in the LDB Flush timer on the node view `OSI > TARP > Config` tab.

13.7.5.3 Manual TARP Adjacencies

TARP adjacencies can be manually provisioned in networks where ONS 15454s must communicate across routers or non-SONET NEs that lack TARP capability. In CTC, manual TARP adjacencies are provisioned on the node view `Provisioning > OSI > TARP > MAT` (Manual Area Table) subtab. The manual adjacency causes a TARP request to hop through the general router or non-SONET NE, as shown in [Figure 13-23](#).

Figure 13-23 Manual TARP Adjacencies

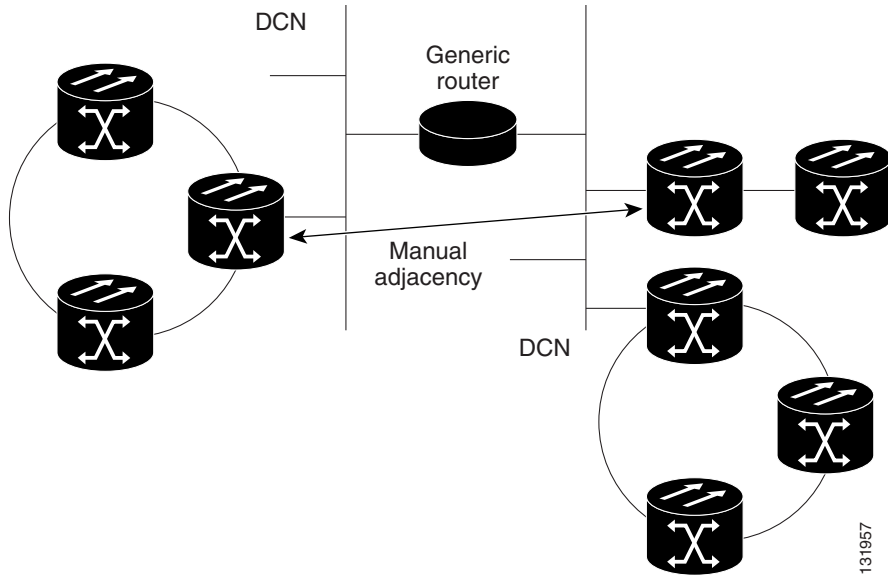

13.7.5.4 Manual TID to NSAP Provisioning

TIDs can be manually linked to NSAPs and added to the TDC. Static TDC entries are similar to static routes. For a specific TID, you force a specific NSAP. Resolution requests for that TID always return that NSAP. No TARP network propagation or instantaneous replies are involved. Static entries allow you to forward TL1 commands to NEs that do not support TARP. However, static TDC entries are not dynamically updated, so outdated entries are not removed after the TID or the NSAP changes on the target node.

13.7.6 TCP/IP and OSI Mediation

Two mediation processes facilitate TL1 networking and file transfers between NEs and ONS client computers running TCP/IP and OSI protocol suites:

- T-TD—Performs a TL1-over-IP to TL1-over-OSI gateway mediation to enable an IP-based OSS to manage OSI-only NEs subtended from a GNE. [Figure 13-24](#) shows the T-TD protocol flow.

Figure 13-24 T-TD Protocol Flow

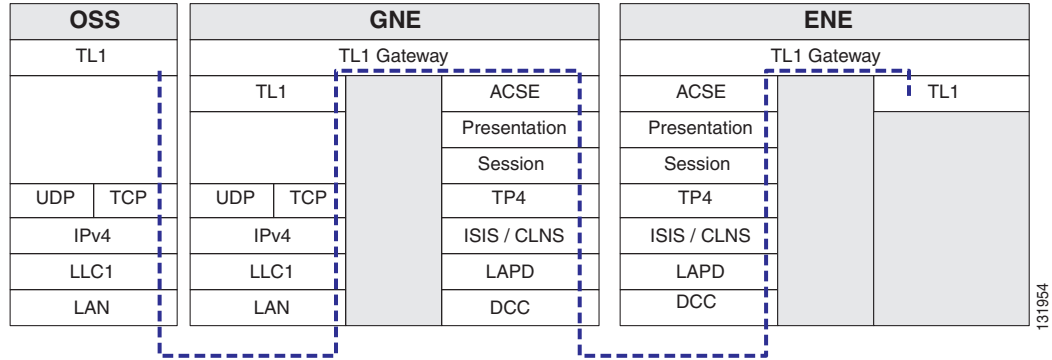

- **FT-TD**—Performs an FTP conversion between FTAM and FTP. The FT-TD gateway entity includes an FTAM responder (server) and an FTP client, allowing FTAM initiators (clients) to store, retrieve, or delete files from an FTP server. The FT-TD gateway is unidirectional and is driven by the FTAM initiator. The FT-TD FTAM responder exchanges messages with the FTAM initiator over the full OSI stack. [Figure 13-25](#) shows the FT-TD protocol flow.

Figure 13-25 FT-TD Protocol Flow

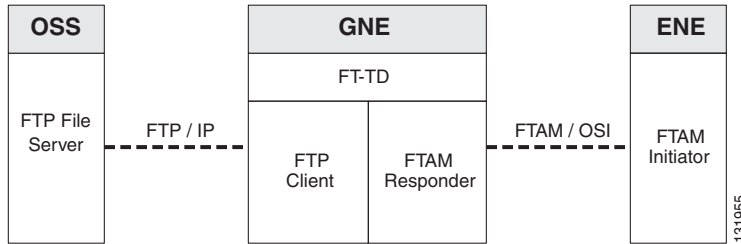

The ONS 15454 uses FT-TD for the following file transfer processes:

- Software downloads
- Database backups and restores
- Cisco IOS configuration backups and restores for ML and ML2 Series cards.

13.7.7 OSI Virtual Routers

The ONS 15454 supports three OSI virtual routers. The routers are provisioned on the Provisioning > OSI > Routers tab, shown in [Figure 13-26](#).

Figure 13-26 Provisioning OSI Routers

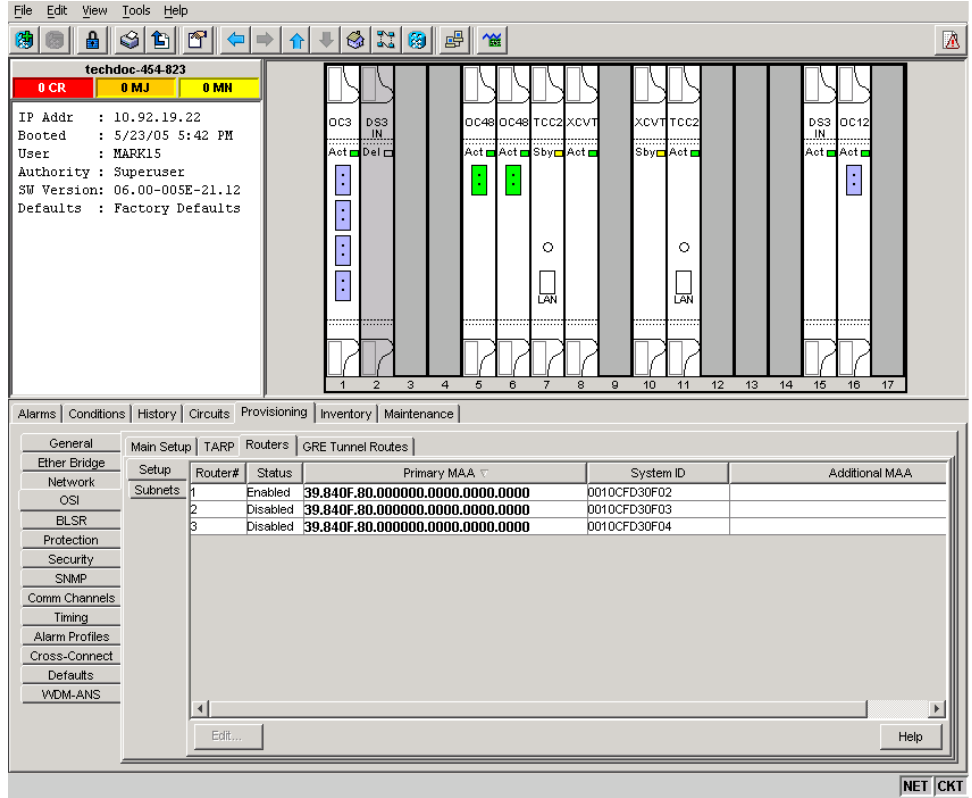

Each router has an editable manual area address and a unique NSAP System ID that is set to the node MAC address + n . For Router 1, $n = 0$. For Router 2, $n = 1$. For Router 3, $n = 2$. Each router can be enabled and connected to different OSI routing areas. However, Router 1 is the primary router, and it must be enabled before Router 2 and Router 3 can be enabled. The Router 1 manual area address and System ID create the NSAP address assigned to the node's TID. In addition, Router 1 supports OSI TARP, mediation, and tunneling functions that are not supported by Router 2 and Router 3. These include:

- TID-to-NSAP resolution
- TARP data cache
- IP-over-CLNS tunnels
- FTAM
- FT-TD
- T-TD
- LAN subnet

OSI virtual router constraints depend on the routing mode provisioned for the node. Table 13-16 shows the number of IS L1s, IS L1/L2s, and DCCs that are supported by each router. An IS Level1 and IS Level1/Level2 support one ES per DCC subnet and up to 100 ESs per LAN subnet.

Table 13-16 OSI Virtual Router Constraints

Routing Mode	Router 1	Router 2	Router 3	IS L1 per area	IS L1/L2 per area	DCC per IS
End System	Yes	No	No	—	—	—
IS L1	Yes	Yes	Yes	250	—	40
IS L1/L2	Yes	Yes	Yes	250	50	40

Each OSI virtual router has a primary manual area address. You can also create two additional manual area addresses. These manual area addresses can be used to:

- Split up an area—Nodes within a given area can accumulate to a point that they are difficult to manage, cause excessive traffic, or threaten to exceed the usable address space for an area. Additional manual area addresses can be assigned so that you can smoothly partition a network into separate areas without disrupting service.
- Merge areas—Use transitional area addresses to merge as many as three separate areas into a single area that shares a common area address.
- Change to a different address—You might need to change an area address for a particular group of nodes. Use multiple manual area addresses to allow incoming traffic intended for an old area address to continue being routed to associated nodes.

13.7.8 IP-over-CLNS Tunnels

IP-over-CLNS tunnels are used to encapsulate IP for transport across OSI NEs. The ONS 15454 supports two tunnel types:

- GRE—Generic Routing Encapsulation is a tunneling protocol that encapsulates one network layer for transport across another. GRE tunnels add both a CLNS header and a GRE header to the tunnel frames. GRE tunnels are supported by Cisco routers and some other vendor NEs.
- Cisco IP—The Cisco IP tunnel directly encapsulates the IP packet with no intermediate header. Cisco IP is supported by most Cisco routers.

Figure 13-24 shows the protocol flow when an IP-over-CLNS tunnel is created through four NEs (A, B, C, and D). The tunnel ends are configured on NEs A and D, which support both IP and OSI. NEs B and C only support OSI, so they only route the OSI packets.

Figure 13-27 IP-over-CLNS Tunnel Flow

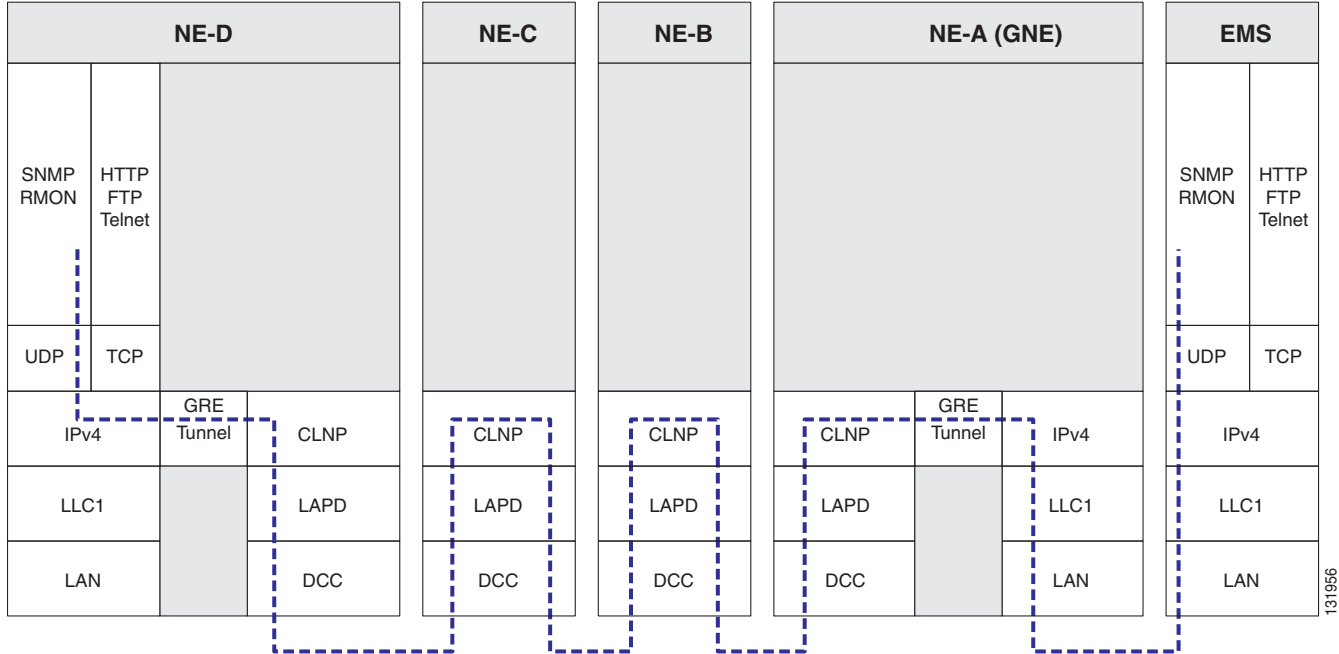

13.7.8.1 Provisioning IP-over-CLNS Tunnels

IP-over-CLNS tunnels must be carefully planned to prevent nodes from losing visibility or connectivity. Before you begin a tunnel, verify that the tunnel type, either Cisco IP or GRE, is supported by the equipment at the other end. Always verify IP and NSAP addresses. Provisioning of IP-over-CLNS tunnels in CTC is performed on the node view Provisioning > OSI > IP over CLNS Tunnels tab. For procedures, refer to the “Turn Up a Node” chapter in the *Cisco ONS 15454 Procedure Guide*.

Provisioning IP-over-CLNS tunnels on Cisco routers requires the following prerequisite tasks, as well as other OSI provisioning:

- (Required) Enable IS-IS
- (Optional) Enable routing for an area on an interface
- (Optional) Assign multiple area addresses
- (Optional) Configure IS-IS interface parameters
- (Optional) Configure miscellaneous IS-IS parameters

The Cisco IOS commands used to create IP-over-CLNS tunnels (CTunnels) are shown in [Table 13-17](#).

Table 13-17 IP-over-CLNS Tunnel IOS Commands

Step	Step	Purpose
1	Router (config) # interface ctunnel <i>interface-number</i>	Creates a virtual interface to transport IP over a CLNS tunnel and enters interface configuration mode. The interface number must be unique for each CTunnel interface.
2	Router (config-if) # ctunnel destination <i>remote-nsap-address</i>	Configures the destination parameter for the CTunnel. Specifies the destination NSAP1 address of the CTunnel, where the IP packets are extracted.
3	Router (config-if) # ip address <i>ip-address mask</i>	Sets the primary or secondary IP address for an interface.

If you are provisioning an IP-over-CLNS tunnel on a Cisco router, always follow procedures provided in the Cisco IOS documentation for the router you are provisioning. For information about ISO CLNS provisioning including IP-over-CLNS tunnels, see the “Configuring ISO CLNS” chapter in the *Cisco IOS Apollo Domain, Banyon VINES, DECnet, ISO CLNS, and XNS Configuration Guide*.

13.7.8.2 IP-over-CLNS Tunnel Scenario 1: ONS Node to Other Vendor GNE

Figure 13-28 shows an IP-over-CLNS tunnel created from an ONS node to another vendor GNE. The other vendor NE has an IP connection to an IP DCN to which a CTC computer is attached. An OSI-only (LAP-D) SDCC and a GRE tunnel are created between the ONS NE 1 to the other vendor GNE.

ONS NE 1 IP-over-CLNS tunnel provisioning information:

- Destination: 10.10.10.100 (CTC 1)
- Mask: 255.255.255.255 for host route (CTC 1 only), or 255.255.255.0 for subnet route (all CTC computers residing on the 10.10.10.0 subnet)
- NSAP: 39.840F.80.1111.0000.1111.1111.cccccccccc.00 (other vendor GNE)
- Metric: 110
- Tunnel Type: GRE

Other vendor GNE IP-over-CLNS tunnel provisioning information:

- Destination: 10.20.30.30 (ONS NE 1)
- Mask: 255.255.255.255 for host route (ONS NE 1 only), or 255.255.255.0 for subnet route (all ONS nodes residing on the 10.30.30.0 subnet)
- NSAP: 39.840F.80.1111.0000.1111.1111.dddddddddd.00 (ONS NE 1)
- Metric: 110
- Tunnel Type: GRE

Figure 13-28 IP-over-CLNS Tunnel Scenario 1: ONS NE to Other Vender GNE

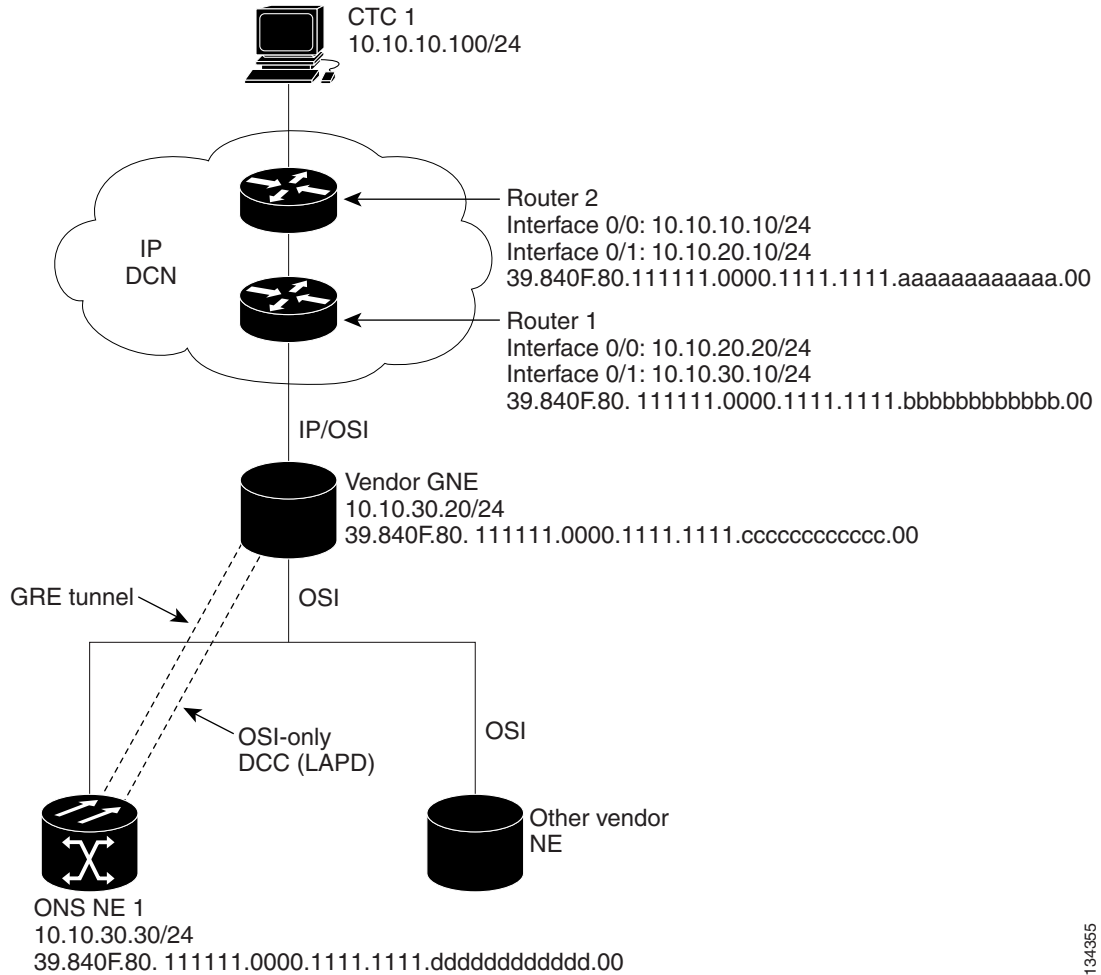

134355

13.7.8.3 IP-over-CLNS Tunnel Scenario 2: ONS Node to Router

Figure 13-29 shows an IP-over-CLNS tunnel from an ONS node to a router. The other vendor NE has an OSI connection to a router on an IP DCN, to which a CTC computer is attached. An OSI-only (LAP-D) SDCC is created between the ONS NE 1 and the other vendor GNE. The OSI over IP tunnel can be either the Cisco IP tunnel or a GRE tunnel, depending on the tunnel types supported by the router.

ONS NE 1 IP-over-CLNS tunnel provisioning:

- Destination: 10.10.30.10 (Router 1, Interface 0/1)
- Mask: 255.255.255.255 for host route (Router 1 only), or 255.255.255.0 for subnet route (all routers on the same subnet)
- NSAP: 39.840F.80.1111.0000.1111.1111.bbbbbbbbbbbb.00 (Router 1)
- Metric: 110
- Tunnel Type: Cisco IP

Router 1 CTunnel (IP-over-CLNS) provisioning:

```
ip routing
```

```

clns routing
interface ctunnel 102
    ip address 10.10.30.30 255.255.255.0
    ctunnel destination 39.840F.80.1111.0000.1111.1111.dddddddddd.00
interface Ethernet0/1
    clns router isis
router isis
    net 39.840F.80.1111.0000.1111.1111.bbbbbbbbbbbb.00
    
```

Figure 13-29 IP-over-CLNS Tunnel Scenario 2: ONS Node to Router

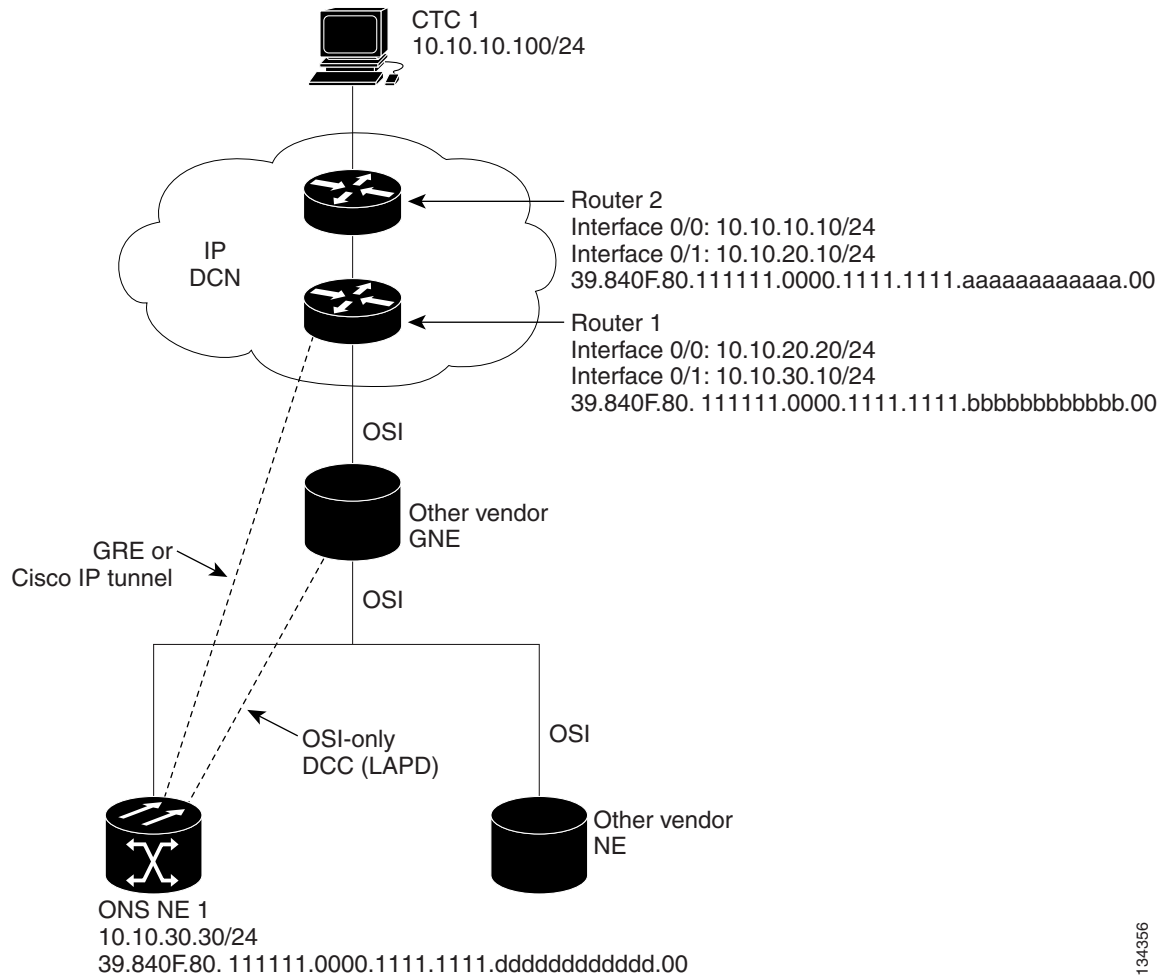

134356

13.7.8.4 IP-over-CLNS Tunnel Scenario 3: ONS Node to Router Across an OSI DCN

Figure 13-30 shows an IP-over-CLNS tunnel from an ONS node to a router across an OSI DCN. The other vendor NE has an OSI connection to an IP DCN to which a CTC computer is attached. An OSI-only (LAP-D) SDCC is created between the ONS NE 1 and the other vendor GNE. The OSI over IP tunnel can be either the Cisco IP tunnel or a GRE tunnel, depending on the tunnel types supported by the router.

ONS NE 1 IP-over-CLNS tunnel provisioning:

- Destination: Router 2 IP address
- Mask: 255.255.255.255 for host route (CTC 1 only), or 255.255.255.0 for subnet route (all CTC computers on the same subnet)
- NSAP: Other vender GNE NSAP address
- Metric: 110
- Tunnel Type: Cisco IP

Router 2 IP-over-CLNS tunnel provisioning (sample Cisco IOS provisioning):

```
ip routing
clns routing
interface ctunnel 102
    ip address 10.10.30.30 255.255.255.0
    ctunnel destination 39.840F.80.1111.0000.1111.1111.dddddddddd.00
interface Ethernet0/1
    clns router isis
router isis
    net 39.840F.80.1111.0000.1111.1111.aaaaaaaaaa.00
```

Figure 13-30 IP-over-CLNS Tunnel Scenario 3: ONS Node to Router Across an OSI DCN

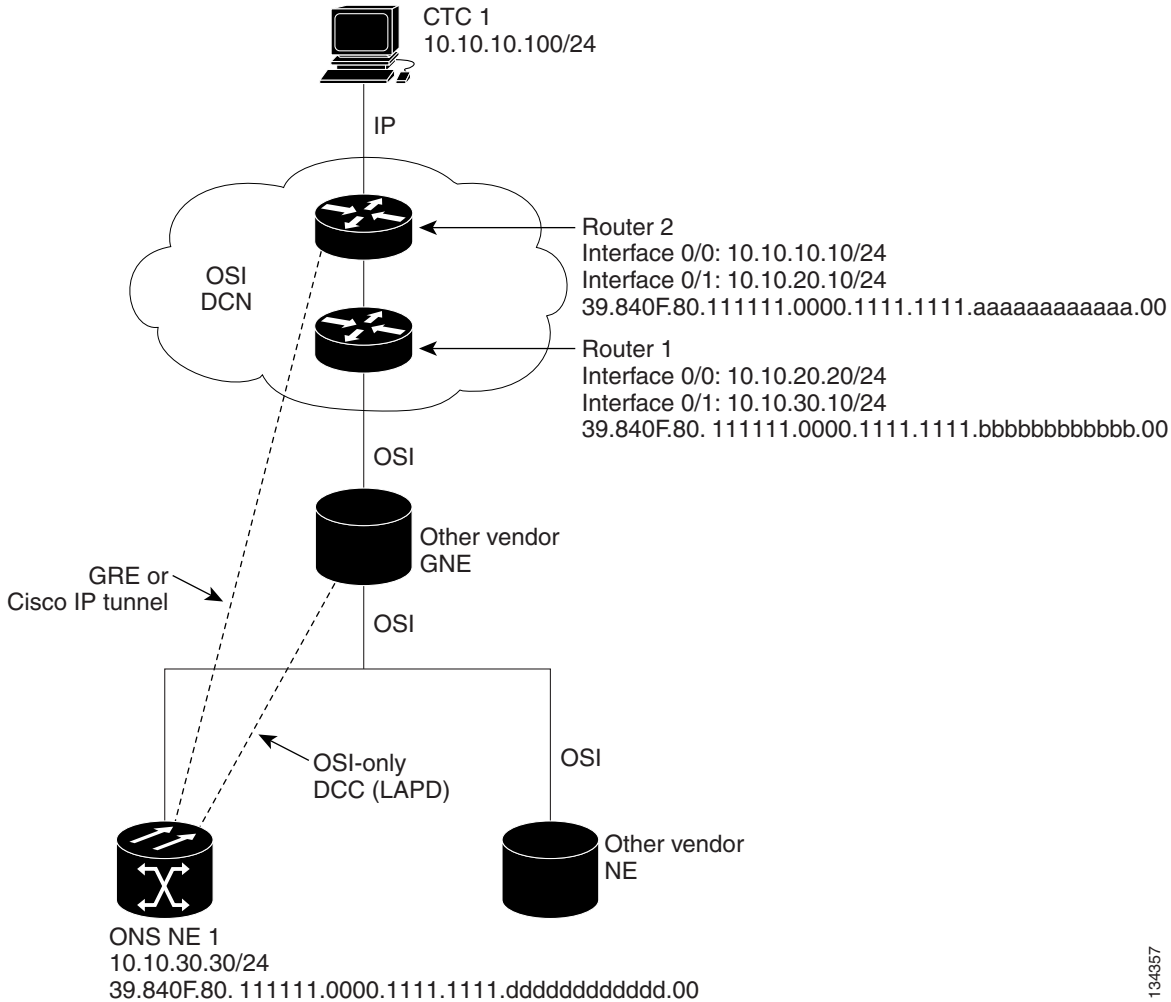

13.7.9 OSI/IP Networking Scenarios

The following eight scenarios show examples of ONS 1545s in networks with OSI-based NEs. The scenarios show ONS 15454 nodes in a variety of roles. The scenarios assume the following:

- ONS 15454 NEs are configured as dual OSI and IP nodes with both IP and NSAP addresses. They run both OSPF and OSI (IS-IS or ES-IS) routing protocols as “Ships-In-The-Night,” with no route redistribution.
- ONS 15454 NEs run TARP, which allows them to resolve a TL1 TID to a NSAP address. A TID might resolve to both an IP and an NSAP address when the destination TID is an ONS 15454 NE that has both IP and NSAP address.
- DCC links between ONS 15454 NEs and OSI-only NEs run the full OSI stack over LAP-D, which includes IS-IS, ES-IS, and TARP.
- DCC links between ONS 15454 NEs run the full OSI stack and IP (OSPF) over PPP.

- All ONS 15454 NEs participating in an OSI network run OSI over PPP between themselves. This is needed so that other vendor GNEs can route TL1 commands to all ONS 15454 NEs participating in the OSI network.

13.7.9.1 OSI/IP Scenario 1: IP OSS, IP DCN, ONS GNE, IP DCC, and ONS ENE

Figure 13-31 shows OSI/IP Scenario 1, the current ONS 15454 IP-based implementation, with an IP DCN, IP-over-PPP DCC, and OSPF routing.

Figure 13-31 OSI/IP Scenario 1: IP OSS, IP DCN, ONS GNE, IP DCC, and ONS ENE

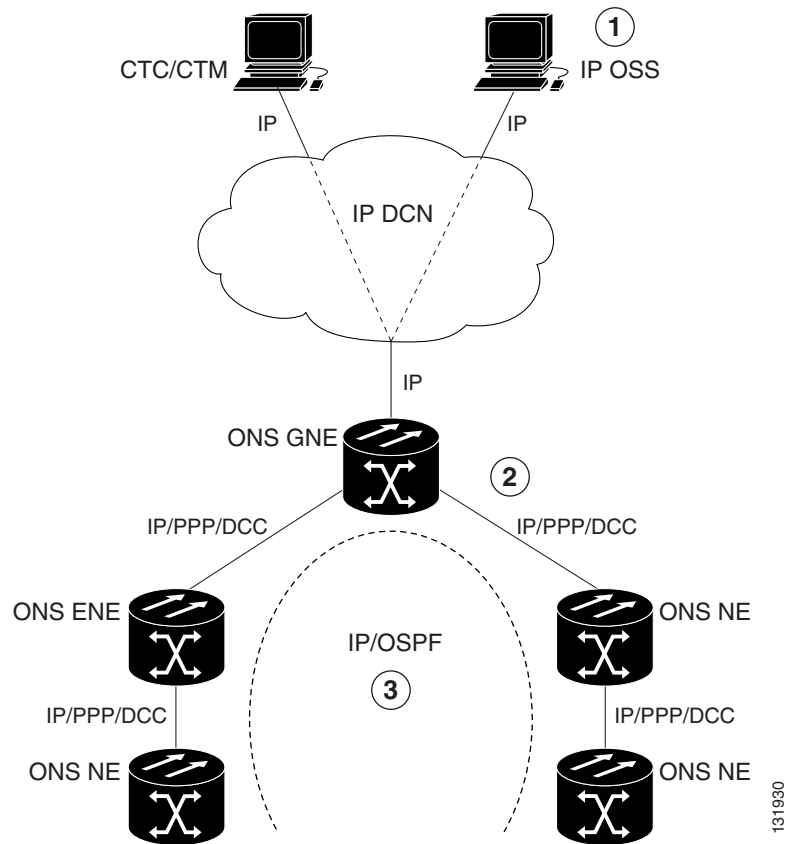

1	IP OSS manages ONS 15454 using TL1 and FTP.
2	DCCs carry IP over the PPP protocol.
3	The ONS 15454 network is managed by IP over OSPF.

13.7.9.2 OSI/IP Scenario 2: IP OSS, IP DCN, ONS GNE, OSI DCC, and Other Vendor ENE

OSI/IP Scenario 2 (Figure 13-32) shows an ONS 15454 GNE in a multivendor OSI network. Both the ONS 15454 GNE and the other vendor NEs are managed by an IP OSS using TL1 and FTP. The ONS 15454 is also managed by CTC and Cisco Transport Manager (CTM). Because the other vendor NE only supports TL1 and FTAM over the full OSI stack, the ONS 15454 GNE provides T-TD and FT-TD mediation to convert TL1/IP to TL1/OSI and FTAM/OSI to FTP/IP.

Figure 13-32 OSI/IP Scenario 2: IP OSS, IP DCN, ONS GNE, OSI DCC, and Other Vendor ENE

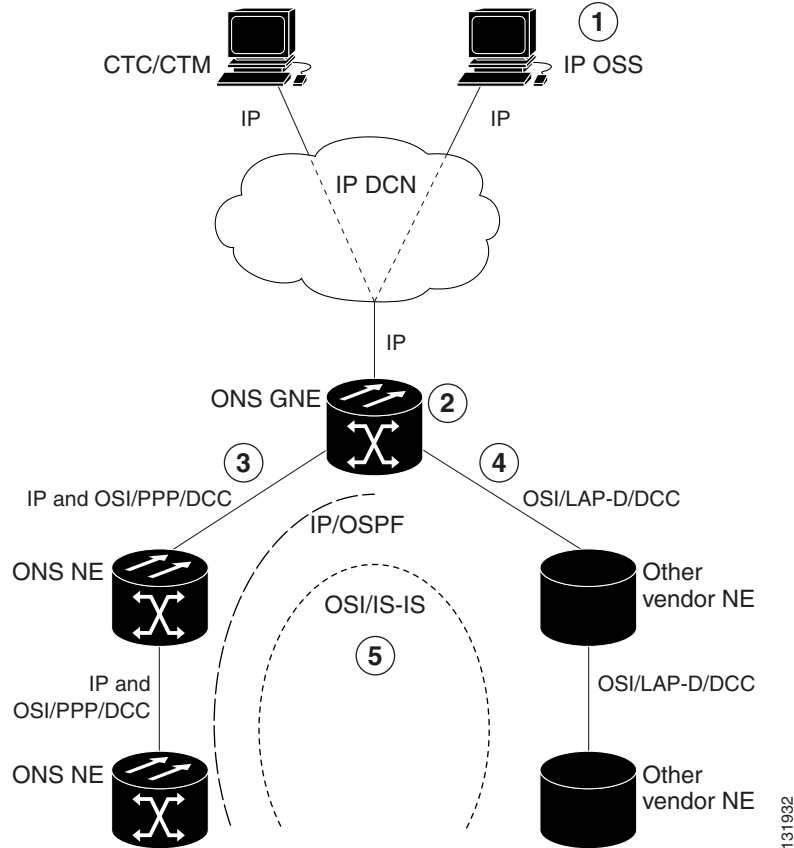

1	The IP OSS manages ONS 15454 and other vendor NEs using TL1 and FTP.
2	The ONS 15454 GNE performs mediation for other vendor NEs.
3	DCCs between the ONS 15454 GNE and ONS 15454 NEs are provisioned for IP and OSI over PPP.
4	DCCs between the ONS 15454 GNE and other vendor NEs are provisioned for OSI over LAP-D.
5	The ONS 15454 and the other vendor NE network include IP over OSPF and OSI over the IS-IS protocol.

The ONS 15454 GNE routes TL1 traffic to the correct NE by resolving the TL1 TID to either an IP or NSAP address. For TL1 traffic to other vendor NEs (OSI-only nodes), the TID is resolved to an NSAP address. The ONS 15454 GNE passes the TL1 to the mediation function, which encapsulates it over the full OSI stack and routes it to the destination using the IS-IS protocol.

For TL1 traffic to ONS 15454 NEs, the TID is resolved to both an IP and an NSAP address. The ONS 15454 GNE follows the current TL1 processing model and forwards the request to the destination NE using the TCP/IP stack and OSPF routing.

OSS-initiated software downloads consist of two parts: the OSS to destination NE TL1 download request and the file transfer. The TL1 request is handled the same as described in the previous paragraph. The ONS 15454 NEs use FTP for file transfers. OSI-only NEs use FTAM to perform file transfers. The FTAM protocol is carried over OSI between the OSI NE and the ONS 15454 GNE. The GNE mediation translates between FTAM to FTP.

13.7.9.3 OSI/IP Scenario 3: IP OSS, IP DCN, Other Vendor GNE, OSI DCC, and ONS ENE

In OSI/IP Scenario 3 (Figure 13-33), all TL1 traffic between the OSS and GNE is exchanged over the IP DCN. TL1 traffic targeted for the GNE is processed locally. All other TL1 traffic is forwarded to the OSI stack, which performs IP-to-OSI TL1 translation. The TL1 is encapsulated in the full OSI stack and sent to the target NE over the DCC. The GNE can route to any node within the IS-IS domain because all NEs, ONS 15454 and non-ONS 15454, have NSAP addresses and support IS-IS routing.

TL1 traffic received by an ONS 15454 NE and not addressed to its NSAP address is forwarded by IS-IS routing to the correct destination. TL1 traffic received by an ONS 15454 NE and addressed to its NSAP is sent up the OSI stack to the mediation function, which extracts the TL1 and passes it to the ONS 15454 TL1 processor.

An OSS initiated software download includes the OSS-to-destination node TL1 download request and the file transfer. The TL1 request is handled as described in the previous paragraph. The target node uses FTAM for file transfers because the GNE does not support IP on the DCC and cannot forward FTP. The ONS 15454 NEs therefore must support an FTAM client and initiate file transfer using FTAM when subtended to an OSI GNE.

In this scenario, the GNE has both IP and OSI DCN connections. The GNE only supports TL1 and FTP over IP. Both are translated and then carried over OSI to the destination ENE (ONS 15454 or OSI-only NE). All other IP traffic is discarded by the GNE. The CTC/CTM IP traffic is carried over an IP-over-OSI tunnel to an ONS 15454 NE. The tunnel is created between an external router and an ONS 15454 NE. The traffic is sent to the ONS 15454 terminating the tunnel. That ONS 15454 then forwards the traffic over the tunnel to CTC/CTM by way of the external router.

Figure 13-33 OSI/IP Scenario 3: IP OSS, IP DCN, Other Vendor GNE, OSI DCC, and ONS ENE

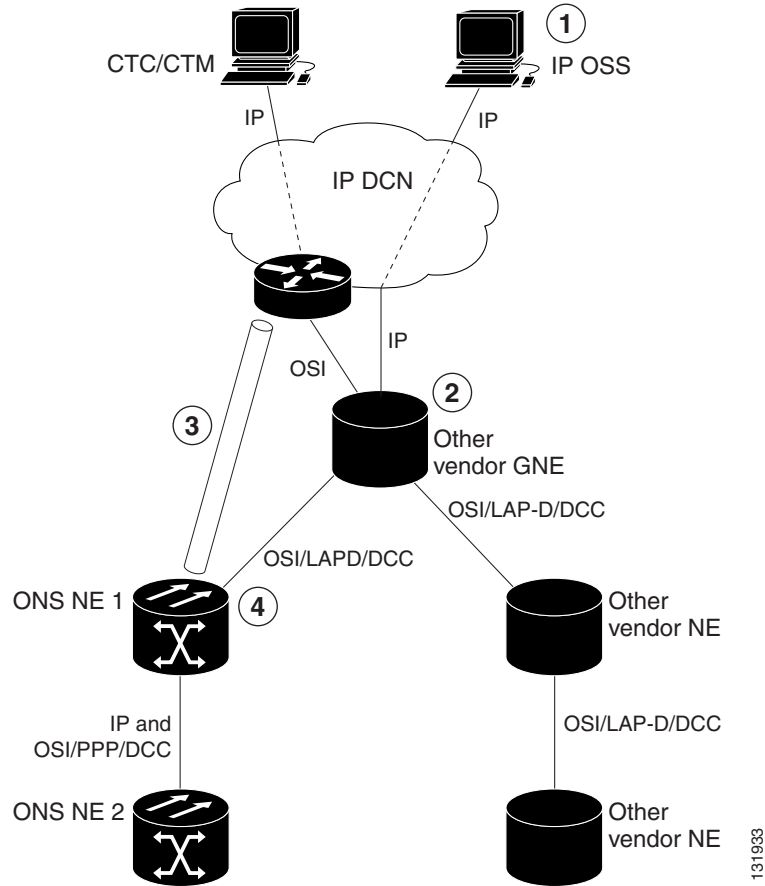

1	The IP OSS manages the ONS 15454 and other vendor NEs using TL1 and FTP.
2	The other vendor GNE performs mediation for TL1 and FTP, so the DCCs to the ONS 15454 and other vendor NEs are OSI-only.
3	CTC/CTM communicates with ONS 15454 NEs over a IP-over-CLNS tunnel. The tunnel is created from the ONS 15454 node to the external router.
4	The ONS 15454 NE exchanges TL1 over the full OSI stack using FTAM for file transfer.

Figure 13-34 shows the same scenario, except the IP-over-CLNS tunnel endpoint is the GNE rather than the DCN router.

Figure 13-34 OSI/IP Scenario 3 with OSI/IP-over-CLNS Tunnel Endpoint at the GNE

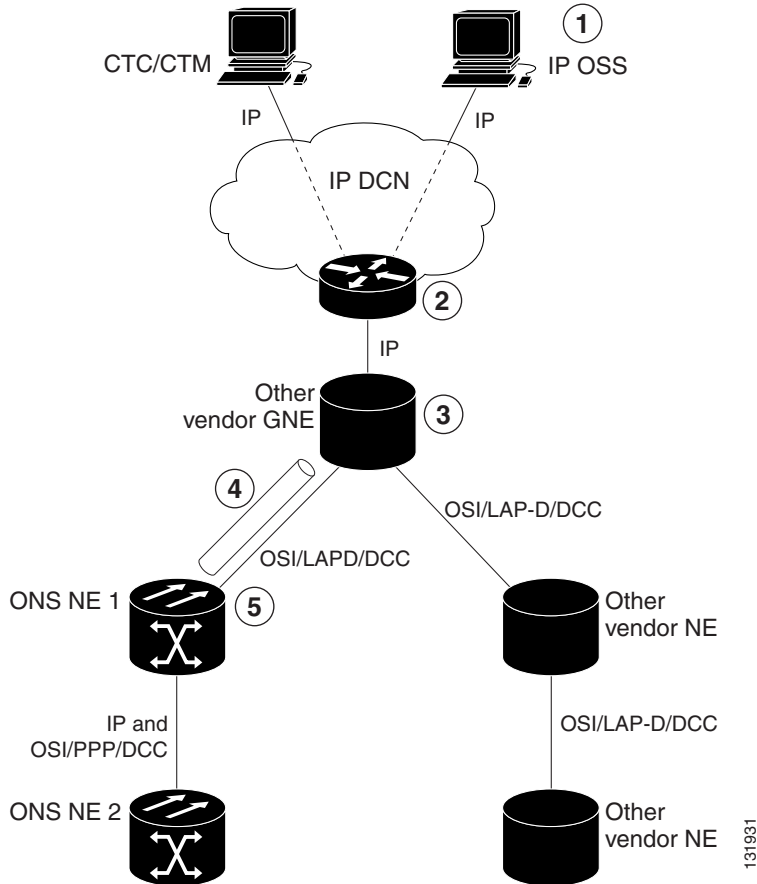

1	The IP OSS manages ONS and other vendor NEs using TL1 and FTP.
2	The router routes requests to the other vendor GNE.
3	The other vendor GNE performs mediation for TL1 and FTP, so the DCCs to ONS 15454 and other vendor NEs are OSI-only.
4	CTC/CTM communicates with ONS 15454 NEs over an IP-over-CLNS tunnel between the ONS 15454 and the GNE.
5	ONS 15454 NEs exchange TL1 over the full OSI stack. FTAM is used for file transfer.

13.7.9.4 OSI/IP Scenario 4: Multiple ONS DCC Areas

OSI/IP Scenario 4 (Figure 13-35) is similar to OSI/IP Scenario 3 except that the OSI GNE is subtended by multiple isolated ONS 15454 areas. A separate IP-over-CLNS tunnel is required to each isolated ONS 15454 OSPF area. An alternate approach is to create a single IP-over-CLNS tunnel from CTC/CTM to an ONS 15454 NE, and then to configure a tunnel from that NE to an NE in each isolated OSPF area. This approach requires additional static routes.

Figure 13-35 OSI/IP Scenario 4: Multiple ONS DCC Areas

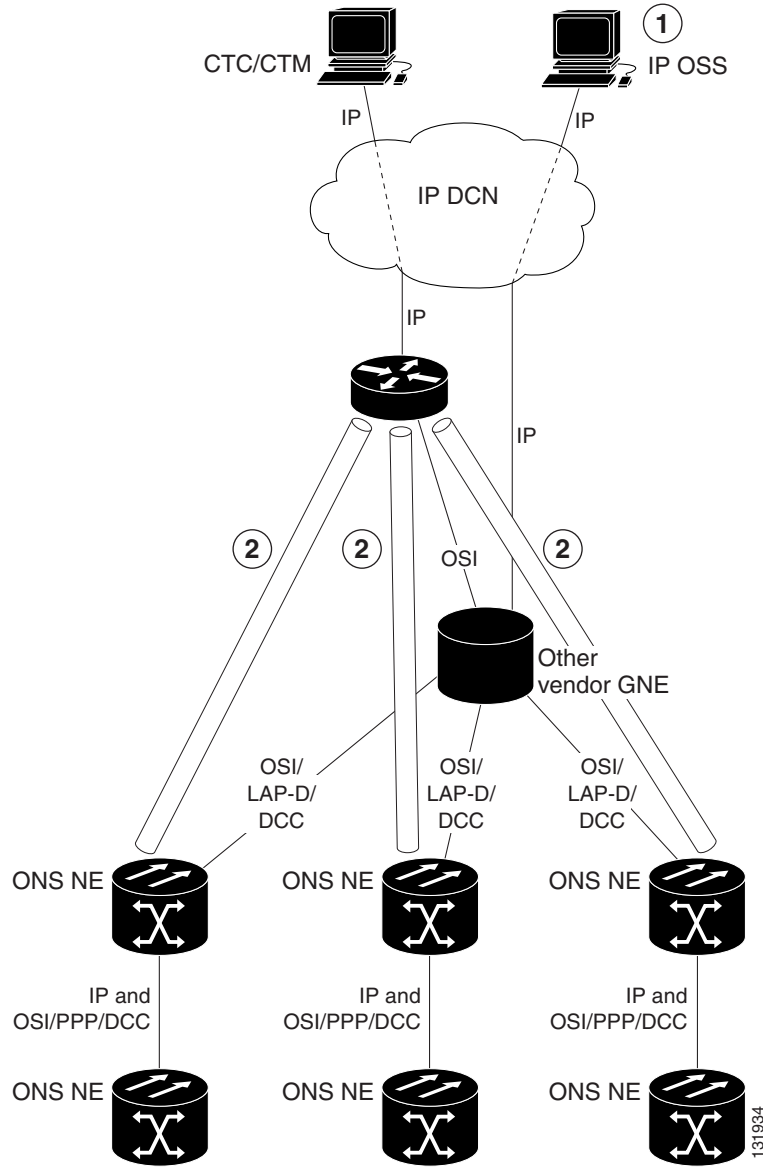

1	The IP OSS manages ONS 15454 and other vendor NEs using TL1 and FTP.
2	A separate tunnel is created for each isolated ONS 15454 DCC area.

13.7.9.5 OSI/IP Scenario 5: GNE Without an OSI DCC Connection

OSI/IP Scenario 5 (Figure 13-36) is similar to OSI/IP Scenario 3 except that the OSI GNE only has an IP connection to the DCN. It does not have an OSI DCN connection to carry CTC/CTM IP traffic through an IP-over-OSI tunnel. A separate DCN to ONS 15454 NE connection is created to provide CTC/CTM access.

Figure 13-36 OSI/IP Scenario 5: GNE Without an OSI DCC Connection

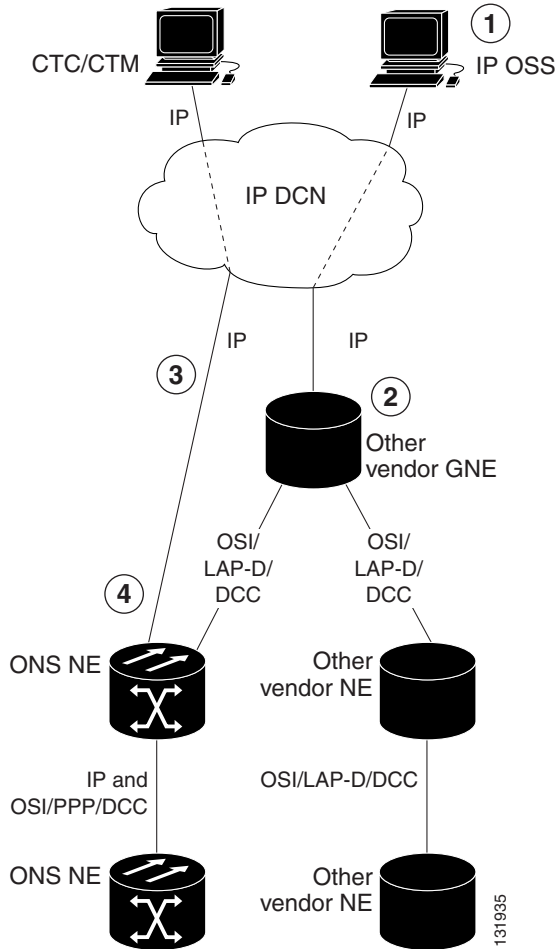

1	The IP OSS manages ONS 15454 and other vendor NEs using TL1 and FTP.
2	The other vendor GNE performs mediation on TL1 and FTP, so DCCs are OSI-only.
3	CTC/CTM communicates with ONS 15454 NEs over a separate IP DCN connection.
4	ONS 15454 NE exchanges TL1 over the full OSI stack. FTAM is used for file transfers.

13.7.9.6 OSI/IP Scenario 6: IP OSS, OSI DCN, ONS GNE, OSI DCC, and Other Vendor ENE

OSI/IP Scenario 6 (Figure 13-37) shows how the ONS 15454 supports OSI DCNs. The OSI DCN has no impact on the ONS 15454 because all IP traffic (CTC/CTM, FTP, and TL1) is tunneled through the OSI DCN.

Figure 13-37 OSI/IP Scenario 6: IP OSS, OSI DCN, ONS GNE, OSI DCC, and Other Vendor ENE

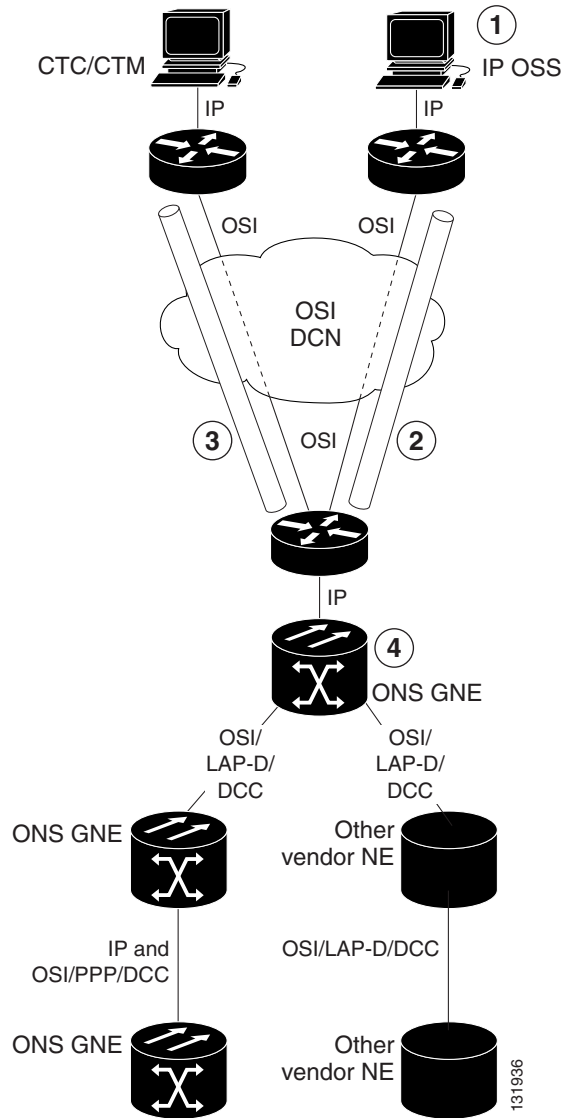

1	The IP OSS manages ONS 15454 and other vendor NEs using TL1 and FTP.
2	OSS IP traffic is tunneled through the DCN to the ONS 15454 GNE.
3	CTC/CTM IP traffic is tunneled through the DCN to the ONS 15454 GNE.
4	The GNE performs mediation for other vendor NEs.

13.7.9.7 OSI/IP Scenario 7: OSI OSS, OSI DCN, Other Vender GNE, OSI DCC, and ONS NEs

OSI/IP Scenario 7 (Figure 13-38) shows an example of a European network.

Figure 13-38 OSI/IP Scenario 7: OSI OSS, OSI DCN, Other Vender GNE, OSI DCC, and ONS NEs

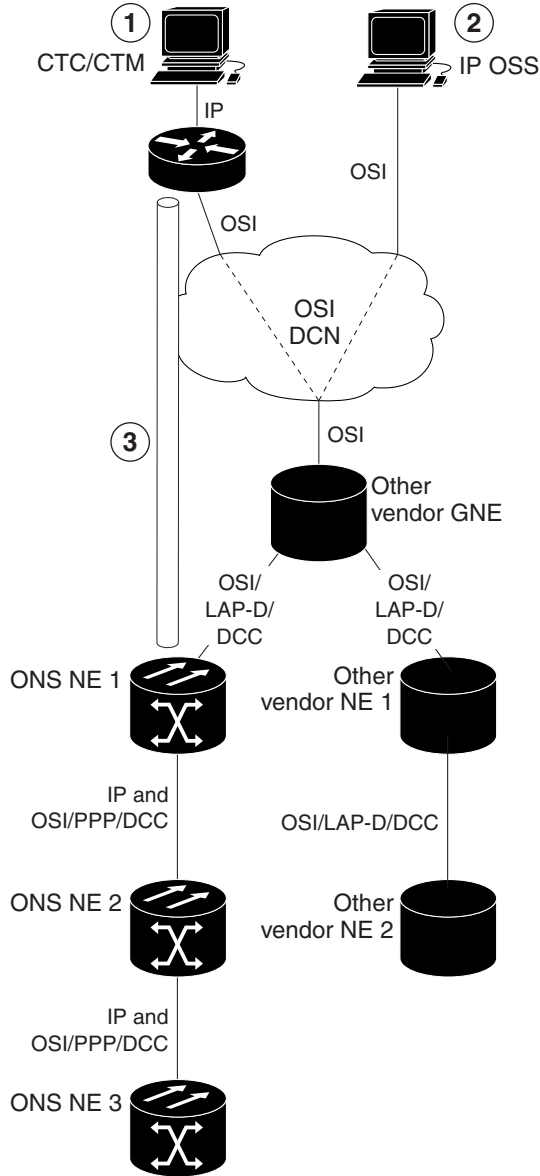

131937

1	ONS 15454 NEs are managed by CTC/CTM only (TL1/FTP is not used).
2	The OSI OSS manages other vendor NEs only.
3	CTC/CTM communicates with the ONS 15454 over a IP-over-CLNS tunnel between the ONS 15454 NE and external router.

In European networks:

- CTC and CTM are used for management only.
- IP-over-CLNS tunnels are widely accepted and deployed.

- TL1 management is not required.
- FTP file transfer is not required.
- TL1 and FTAM to FTP mediation is not required.

Management traffic between CTC/CTM and ONS 15454 NEs is carried over an IP-over-CLNS tunnel. A static route is configured on the ONS 15454 that terminates the tunnel (ONS 15454 NE 1) so that downstream ONS 15454 NEs (ONS 15454 NE 2 and 3) know how to reach CTC/CTM.

13.7.9.8 OSI/IP Scenario 8: OSI OSS, OSI DCN, ONS GNE, OSI DCC, and Other Vendor NEs

OSI/IP Scenario 8 (Figure 13-39) is another example of a European network. Similar to OSI/IP Scenario 7, the ONS 15454 NEs are solely managed by CTC/CTM. The CTC/CTM IP traffic is carried over a IP-over-OSI tunnel between an external router and the ONS 15454 GNE. The GNE extracts the IP from the tunnel and forwards it to the destination ONS 15454. Management traffic between the OSS and other vendor NEs is routed by the ONS 15454 GNE and NEs. This is possible because all ONS 15454 NEs run dual stacks (OSI and IP).

Figure 13-39 OSI/IP Scenario 8: OSI OSS, OSI DCN, ONS GNE, OSI DCC, and Other Vender NEs

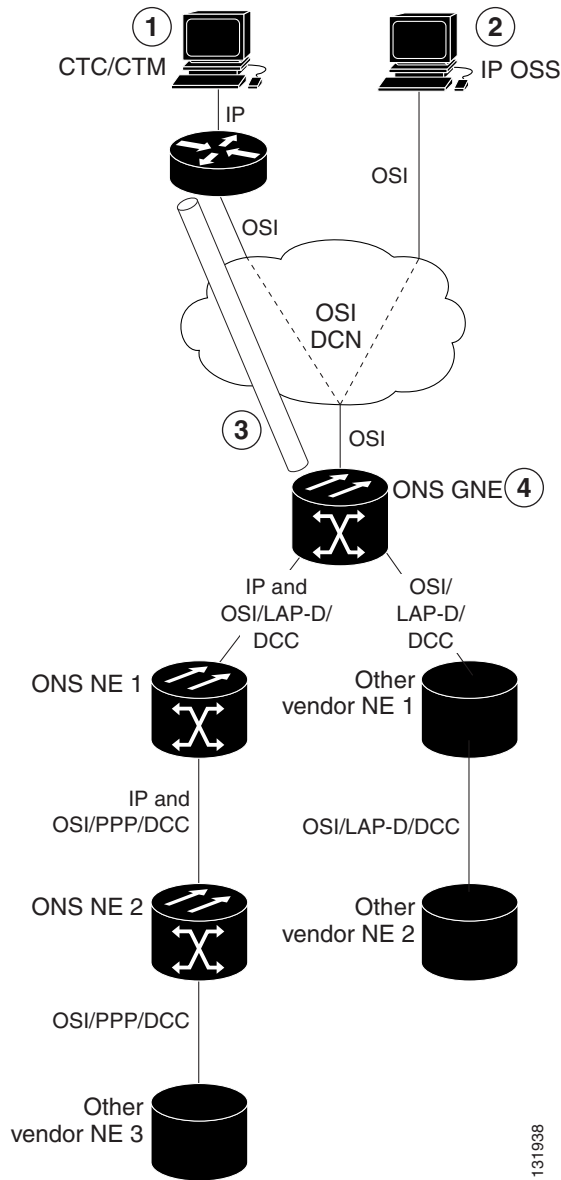

1	The ONS NEs are managed by CTC/CTM only (TL1/FTP is not used).
2	The OSI OSS manages other vendor NEs only.
3	CTC/CTM communicates with the ONS 15454 over an IP-over-CLNS tunnel between the ONS 15454 NE and the external router. A static route is needed on the GNE.
4	The ONS 15454 GNE routes OSI traffic to other vendor NEs. No IP-over-CLNS tunnel is needed.

13.7.10 Provisioning OSI in CTC

Table 13-18 shows the OSI actions that are performed from the node view Provisioning tab. Refer to the *Cisco ONS 15454 Procedure Guide* for OSI procedures and tasks.

Table 13-18 OSI Actions from the CTC Provisioning Tab

Tab	Actions
OSI > Main Setup	<ul style="list-style-type: none"> View and edit Primary Area Address. Change OSI routing mode. Change LSP buffers.
OSI > TARP > Config	Configure the TARP parameters: <ul style="list-style-type: none"> PDU L1/L2 propagation and origination. TARP data cache and loop detection buffer. LAN storm suppression. Type 4 PDU on startup. TARP timers: LDB, T1, T2, T3, T4.
OSI > TARP > Static TDC	Add and delete static TARP data cache entries.
OSI > TARP > MAT	Add and delete static manual area table entries.
OSI > Routers > Setup	<ul style="list-style-type: none"> Enable and disable routers. Add, delete, and edit manual area addresses.
OSI > Routers > Subnets	Edit SDCC, LDCC, and LAN subnets that are provisioned for OSI.
OSI > Tunnels	Add, delete, and edit Cisco and IP-over-CLNS tunnels.
Comm Channels > SDCC	<ul style="list-style-type: none"> Add OSI configuration to an SDCC. Choose the data link layer protocol, PPP or LAP-D.
Comm Channels > LDCC	<ul style="list-style-type: none"> Add OSI configuration to an SDCC.

Table 13-19 shows the OSI actions that are performed from the node view Maintenance tab.

Table 13-19 OSI Actions from the CTC Maintenance Tab

Tab	Actions
OSI > ISIS RIB	View the IS-IS routing table.
OSI > ESIS RIB	View ESs that are attached to ISs.
OSI > TDC	<ul style="list-style-type: none"> View the TARP data cache and identify static and dynamic entries. Perform TID to NSAP resolutions. Flush the TDC.



CHAPTER 14

Alarm Monitoring and Management

This chapter describes Cisco Transport Controller (CTC) alarm management. To troubleshoot specific alarms, refer to the *Cisco ONS 15454 Troubleshooting Guide*. Chapter topics include:

- [14.1 Overview, page 14-1](#)
- [14.2 LCD Alarm Counts, page 14-1](#)
- [14.3 Alarm Information, page 14-2](#)
- [14.4 Alarm Severities, page 14-9](#)
- [14.5 Alarm Profiles, page 14-9](#)
- [14.6 Alarm Suppression, page 14-13](#)
- [14.7 External Alarms and Controls, page 14-14](#)

14.1 Overview

CTC detects and reports SONET alarms generated by the Cisco ONS 15454 and the larger SONET network. You can use CTC to monitor and manage alarms at the card, node, or network level. Alarming conforms to Telcordia GR-253 standard. Severities conform to Telcordia GR-474, but you can set alarm severities in customized alarm profiles or suppress CTC alarm reporting. For a detailed description of the standard Telcordia categories employed by Optical Networking System (ONS) nodes, refer to the *Cisco ONS 15454 Troubleshooting Guide*.



Note

ONS 15454 alarms can also be monitored and managed through Transaction Language One (TL1) or a network management system (NMS).

14.2 LCD Alarm Counts

You can view node, slot, or port-level alarm counts and summaries using the buttons on the ONS 15454 LCD panel. The Slot and Port buttons toggle between display types; the Slot button toggles between node display and slot display, and the Port button toggles between slot and port views. Pressing the Status button after you choose the display mode changes the display from alarm count to alarm summary.

The ONS 15454 has a one-button update for some commonly viewed alarm counts. If you press the Slot button once and then wait eight seconds, the display automatically changes from a slot alarm count to a slot alarm summary. If you press the Port button to toggle to port-level display, you can use the Port button to toggle to a specific slot and to view each port's port-level alarm count. Figure 14-1 shows the LCD panel layout.

Figure 14-1 Shelf LCD Panel

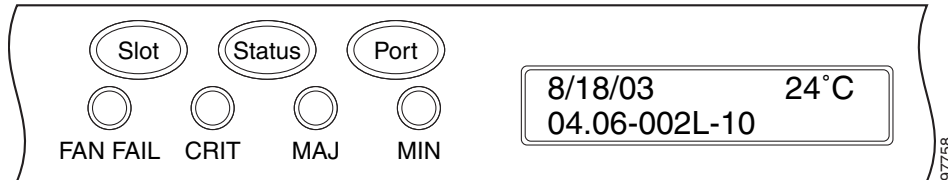

14.3 Alarm Information

You can use the Alarms tab to view card, node, or network-level alarms. The Alarms window shows alarms in conformance with Telcordia GR-253. This means that if a network problem causes two alarms, such as loss of frame (LOF) and loss of signal (LOS), CTC only shows the LOS alarm in this window because it supersedes LOF. (The LOF alarm can still be retrieved in the Conditions window.)

The Path Width column in the Alarms and Conditions tabs expands upon alarmed object information contained in the access identifier (AID) string (such as "STS-4-1-3") by giving the number of STSs contained in the alarmed path. For example, the Path Width will tell you whether a critical alarm applies to an STS1 or an STS48c. The column reports the width as a 1, 3, 6, 12, 48, etc. as appropriate, understood to be "STS-N."

Table 14-1 lists the column headings and the information recorded in each column.

Table 14-1 Alarms Column Descriptions

Column	Information Recorded
Num	Num (number) is the quantity of alarm messages received, and is incremented automatically as alarms occur to display the current total of received error messages. (The column is hidden by default; to view it, right-click a column and choose Show Column > Num .)
Ref	Ref (reference) is a unique identification number assigned to each alarm to reference a specific alarm message that is displayed. (The column is hidden by default. To view it, right-click a column and choose Show Column .)
New	Indicates a new alarm. To change this status, click either the Synchronize button or the Delete Cleared Alarms button.
Date	Date and time of the alarm.
Node	Shows the name of the node where the condition or alarm occurred. (Visible in network view.)
Object	TL1 AID for the alarmed object. For an STSmon or VTmon, this is the monitored STS or VT object.
Eqpt Type	Card type in this slot.

Table 14-1 Alarms Column Descriptions (continued)

Column	Information Recorded
Shelf	For dense wavelength division multiplexing (DWDM) configurations, the shelf where the alarmed object is located. Visible in network view.
Slot	Slot where the alarm occurred (appears only in network and node view).
Port	Port where the alarm is raised. For STSTerm and VTSTerm, the port refers to the upstream card it is partnered with.
Path Width	Indicates how many STSs are contained in the alarmed path. This information complements the alarm object notation, which is explained in the “Alarm Troubleshooting” chapter of the <i>Cisco ONS 15454 Troubleshooting Guide</i> .
Sev	Severity level: CR (Critical), MJ (Major), MN (Minor), NA (Not Alarmed), NR (Not Reported).
ST	Status: R (raised), C (clear), or T (transient).
SA	When checked, indicates a service-affecting alarm.
Cond	The error message/alarm name. These names are alphabetically defined in the “Alarm Troubleshooting” chapter of the <i>Cisco ONS 15454 Troubleshooting Guide</i> .
Description	Description of the alarm.

**Note**

When an entity is put in the OOS,MT administrative state, the ONS 15454 suppresses all standing alarms on that entity. All alarms and events appear on the Conditions tab. You can change this behavior for the LPBKFACILITY and LPBKTERMINAL alarms. To display these alarms on the Alarms tab, set the NODE.general.ReportLoopbackConditionsOnPortsInOOS-MT to TRUE on the NE Defaults tab.

Table 14-2 lists the color codes for alarm and condition severities. The inherited (I) and unset (U) severities are only listed in the network view Provisioning > Alarm Profiles tab.

Table 14-2 Color Codes for Alarm and Condition Severities

Color	Description
Red	Raised Critical (CR) alarm
Orange	Raised Major (MJ) alarm
Yellow	Raised Minor (MN) alarm
Magenta	Raised Not Alarmed (NA) condition
Blue	Raised Not Reported (NR) condition
White	Cleared (C) alarm or condition

**Note**

Major and Minor alarms might appear yellow in CTC under certain circumstances. This is not due to a CTC problem but to a workstation memory and color utilization problem. For example, a workstation might run out of colors if many color-intensive applications are running. When using Netscape, you can limit the number of colors used by launching it from the command line with either the -install option or the -ncols 32 option.

14.3.1 Viewing Alarms With Each Node's Time Zone

By default, alarms and conditions are displayed with the time stamp of the CTC workstation where you are viewing them. But you can set the node to report alarms (and conditions) using the time zone where the node is located by clicking Edit > Preferences, and clicking the Display Events Using Each Node's Timezone check box.

14.3.2 Controlling Alarm Display

You can control the display of the alarms shown on the Alarms window. [Table 14-3](#) shows the actions you can perform in the Alarms window.

Table 14-3 Alarm Display

Button/Check Box/Tool	Action
Filter button	Allows you to change the display on the Alarms window to show only alarms that meet a certain severity level, occur in a specified time frame, and/or reflect specific conditions. For example, you can set the filter so that only critical alarms display on the window. If you enable the Filter feature by clicking the Filter button in one CTC view, such as node view, it is enabled in the others as well (card view and network view).
Synchronize button	Updates the alarm display. Although CTC displays alarms in real time, the Synchronize button allows you to verify the alarm display. This is particularly useful during provisioning or troubleshooting.
Delete Cleared Alarms button	Deletes, from the view, alarms that have been cleared.
AutoDelete Cleared Alarms check box	If checked, CTC automatically deletes cleared alarms.
Filter tool	Enables or disables alarm filtering in the card, node, or network view. When enabled or disabled, this state applies to other views for that node and for all other nodes in the network. For example, if the Filter tool is enabled in the node (default login) view Alarms window, the network view Alarms window and card view Alarms window also show the tool enabled. All other nodes in the network also show the tool enabled.

14.3.3 Filtering Alarms

The alarm display can be filtered to prevent display of alarms with certain severities or alarms that occurred between certain dates and times. You can set the filtering parameters by clicking the Filter button at the bottom-left of the Alarms window. You can turn the filter on or off by clicking the Filter tool at the bottom-right of the window. CTC retains your filter activation setting. For example, if you turn the filter on and then log out, CTC keeps the filter active the next time you log in.

14.3.4 Viewing Alarm-Affected Circuits

A user can view which ONS 15454 circuits are affected by a specific alarm by positioning the cursor over the alarm in the Alarm window and right-clicking. A shortcut menu appears (Figure 14-2). When the user selects the Select Affected Circuits option, the Circuits window opens to show the circuits that are affected by the alarm.

Figure 14-2 Select Affected Circuits Option

Num	Ref	New	Date	Object	Eqpt Type	Slot	Port	Path Width	Sev	ST	SA	Cond	Descriptor
2304	2304		08/23/05 15:45:07 CDT	DS3	DS3	2	1		CR	R	✓	LOS	Loss Of Signal
2303	2303		08/23/05 15:46:01 CDT	FAC-1-M	DS1	1	1		MJ	R	✓	RCVR-MISS	Facility Termination Equipment
2302	2302		08/23/05 15:46:01 CDT	FAC-1-M	DS1	1	1		MJ	R	✓	TRMT-MISS	Facility Termination Equipment
2301	2301		08/23/05 15:46:01 CDT	FAC-1-1	DS1	1	1		MJ	R	✓	LOS	Loss Of Signal
2300	2300		08/23/05 15:45:13 CDT	PWR-A					MJ	R	✓	HBATVVG	High Volt
2298	2298		08/23/05 15:45:21 CDT	PWR-B					MN	R		BAT-FAIL	Battery Failure
2295	2295		08/23/05 15:45:07 CDT	SYNC-NE					MN	R		SYNCSEC	Secondary Synchronization R
2294	2294		08/23/05 15:45:07 CDT	SYNC-NE					MJ	R	✓	SYNCPRI	Primary Synchronization Refer
2291	2291		08/23/05 15:45:07 CDT	BITS-2					MN	R		LOS	Loss Of Signal
2289	2289		08/23/05 15:45:07 CDT	BITS-2					MN	R		LOS	Loss Of Signal
2284	2284		08/23/05 15:45:01 CDT	SLOT-11	TCC		11		MN	R		PROTNA	Protection Unit Not Available
2283	2283		08/23/05 15:45:01 CDT	SLOT-8	XCVT		8		MN	R		PROTNA	Protection Unit Not Available

14.3.5 Conditions Tab

The Conditions window displays retrieved fault conditions. A condition is a fault or status detected by ONS 15454 hardware or software. When a condition occurs and continues for a minimum period, CTC raises a condition, which is a flag showing that this particular condition currently exists on the ONS 15454.

The Conditions window shows all conditions that occur, including those that are superseded. For instance, if a network problem causes two alarms, such as LOF and LOS, CTC shows both the LOF and LOS conditions in this window (even though LOS supersedes LOF). Having all conditions visible can be helpful when troubleshooting the ONS 15454. If you want to retrieve conditions that obey a root-cause hierarchy (that is, LOS supersedes and replaces LOF), you can exclude the same root causes by checking “Exclude Same Root Cause” check box in the window.

Fault conditions include reported alarms and Not Reported or Not Alarmed conditions. Refer to the trouble notifications information in the *Cisco ONS 15454 Troubleshooting Guide* for more information about alarm and condition classifications.

14.3.6 Controlling the Conditions Display

You can control the display of the conditions on the Conditions window. [Table 14-4](#) shows the actions you can perform in the window.

Table 14-4 Conditions Display

Button	Action
Retrieve	Retrieves the current set of all existing fault conditions, as maintained by the alarm manager, from the ONS 15454.
Filter	Allows you to change the Conditions window display to only show the conditions that meet a certain severity level or occur in a specified time. For example, you can set the filter so that only critical conditions display on the window. There is a Filter button on the lower-right of the window that allows you to enable or disable the filter feature.
Exclude Same Root Cause	Retrieves conditions that obey a root-cause hierarchy (for example, LOS supersedes and replaces LOF).

14.3.6.1 Retrieving and Displaying Conditions

The current set of all existing conditions maintained by the alarm manager can be seen when you click the Retrieve button. The set of conditions retrieved is relative to the view. For example, if you click the button while displaying the node view, node-specific conditions are displayed. If you click the button while displaying the network view, all conditions for the network (including ONS 15454 nodes and other connected nodes) are displayed, and the card view shows only card-specific conditions.

You can also set a node to display conditions using the time zone where the node is located, rather than the time zone of the PC where they are being viewed. See the “[14.3.1 Viewing Alarms With Each Node’s Time Zone](#)” section on [page 14-4](#) for more information.

14.3.6.2 Conditions Column Descriptions

[Table 14-5](#) lists the Conditions window column headings and the information recorded in each column.

Table 14-5 Conditions Column Description

Column	Information Recorded
Date	Date and time of the condition.
Node	Shows the name of the node where the condition or alarm occurred. (Visible in network view.)
Object	TL1 AID for the condition object. For an STSmon or VTmon, the object.
Eqpt Type	Card type in this slot.
Shelf	For DWDM configurations, the shelf where the alarmed object is located. Visible in network view.
Slot	Slot where the condition occurred (appears only in network and node view).
Port	Port where the condition occurred. For STSTerm and VTTerm, the port refers to the upstream card it is partnered with.

Table 14-5 Conditions Column Description (continued)

Column	Information Recorded
Path Width	Width of the data path.
Sev ¹	Severity level: CR (Critical), MJ (Major), MN (Minor), NA (Not Alarmed), NR (Not Reported).
SA ¹	Indicates a service-affecting alarm (when checked).
Cond	The error message/alarm name; these names are alphabetically defined in the “Alarm Troubleshooting” chapter of the <i>Cisco ONS 15454 Troubleshooting Guide</i> .
Description	Description of the condition.

1. All alarms, their severities, and service-affecting statuses are also displayed in the Condition tab unless you choose to filter the alarm from the display using the Filter button.

14.3.6.3 Filtering Conditions

The condition display can be filtered to prevent display of conditions (including alarms) with certain severities or that occurred between certain dates. You can set the filtering parameters by clicking the Filter button at the bottom-left of the Conditions window. You can turn the filter on or off by clicking the Filter tool at the bottom-right of the window. CTC retains your filter activation setting. For example, if you turn the filter on and then log out, CTC keeps the filter active the next time your user ID is activated.

14.3.7 Viewing History

The History window displays historic alarm or condition data for the node or for your login session. You can choose to display only alarm history, only events, or both by checking check boxes in the History > Shelf window. You can view network-level alarm and condition history, such as for circuits, for all the nodes visible in network view. At the node level, you can see all port (facility), card, STS, and system-level history entries for that node. For example, protection-switching events or performance-monitoring threshold crossings appear here. If you double-click a card, you can view all port, card, and STS alarm or condition history that directly affects the card.



Note

In the Preference dialog General tab, the Maximum History Entries value only applies to the Session window.

Different views of CTC display different kinds of history:

- The History > Session window is shown in network view, node view, and card view. It shows alarms and conditions that occurred during the current user CTC session.
- The History > Shelf window is only shown in node view. It shows the alarms and conditions that occurred on the node since CTC software was operated on the node.
- The History > Card window is only shown in card view. It shows the alarms and conditions that occurred on the card since CTC software was installed on the node.



Tip

Double-click an alarm in the History window to display the corresponding view. For example, double-clicking a card alarm takes you to card view. In network view, double-clicking a node alarm takes you to node view.

If you check the History window Alarms check box, you display the node history of alarms. If you check the Events check box, you display the node history of Not Alarmed and transient events (conditions). If you check both check boxes, you retrieve node history for both.

14.3.7.1 History Column Descriptions

Table 14-6 lists the History window column headings and the information recorded in each column.

Table 14-6 History Column Description

Column	Information Recorded
Num	An incrementing count of alarm or condition messages. (The column is hidden by default; to view it, right-click a column and choose Show Column > Num.)
Ref	The reference number assigned to the alarm or condition. (The column is hidden by default; to view it, right-click a column and choose Show Column > Ref.)
Date	Date and time of the condition.
Node	Shows the name of the node where the condition or alarm occurred. (Visible in network view.)
Object	TL1 AID for the condition object. For an STSmon or VTmon, the object.
Eqpt Type	Card type in this slot.
Shelf	For DWDM configurations, the shelf where the alarmed object is located. Visible in network view.
Slot	Slot where the condition occurred (only displays in network view and node view).
Port	Port where the condition occurred. For STSTerm and VTTerm, the port refers to the upstream card it is partnered with.
Path Width	Width of the data path.
Sev	Severity level: Critical (CR), Major (MJ), Minor (MN), Not Alarmed (NA), Not Reported (NR).
ST	Status: raised (R), cleared (C), or transient (T).
SA	Indicates a service-affecting alarm (when checked).
Cond	Condition name.
Description	Description of the condition.

14.3.7.2 Retrieving and Displaying Alarm and Condition History

You can retrieve and view the history of alarms and conditions, as well as transients (passing notifications of processes as they occur) in the CTC history window. The information in this window is specific to the view where it is shown (that is, network history in the network view, node history in the node view, and card history in the card view).

The node and card history views are each divided into two tabs. In node view, when you click the Retrieve button, you can see the history of alarms, conditions, and transients that have occurred on the node in the History > Shelf window, and the history of alarms, conditions, and transients that have occurred on the node during your login session in the History > Session window. In the card-view history window, after you retrieve the card history, you can see the history of alarms, conditions, and transients

on the card in the History > Card window, or a history of alarms, conditions, and transients that have occurred during your login session in the History > Session window. You can also filter the severities and occurrence period in these history windows.

14.3.8 Alarm History and Log Buffer Capacities

The ONS 15454 alarm history log, stored in the TCC2/TCC2P RSA memory, contains four categories of alarms. These include:

- CR severity alarms
- MJ severity alarms
- MN severity alarms
- the combined group of cleared, Not Alarmed severity, and Not Reported severity alarms

Each category can store between 4 and 640 alarm chunks, or entries. In each category, when the upper limit is reached, the oldest entry in the category is deleted. The capacity is not user-provisionable.

CTC also has a log buffer, separate from the alarm history log, that pertains to the total number of entries displayed in the Alarms, Conditions, and History windows. The total capacity is provisionable up to 5,000 entries. When the upper limit is reached, the oldest entries are deleted.

14.4 Alarm Severities

ONS 15454 alarm severities follow the Telcordia GR-253 standard, so a condition might be Alarmed (at a severity of Critical [CR], Major [MJ], or Minor [MN]), Not Alarmed (NA), or Not Reported (NR). These severities are reported in the CTC software Alarms, Conditions, and History windows at all levels: network, shelf, and card.

ONS equipment provides a standard profile named Default listing all alarms and conditions with severity settings based on Telcordia GR-474 and other standards, but users can create their own profiles with different settings for some or all conditions and apply these wherever desired. (See the [“14.5 Alarm Profiles” section on page 14-9](#).) For example, in a custom alarm profile, the default severity of a carrier loss (CARLOSS) alarm on an Ethernet port could be changed from major to critical. The profile allows setting to Not Reported or Not Alarmed, as well as the three alarmed severities.

Critical and Major severities are only used for service-affecting alarms. If a condition is set as Critical or Major by profile, it will raise as Minor alarm in the following situations:

- In a protection group, if the alarm is on a standby entity (side not carrying traffic)
- If the alarmed entity has no traffic provisioned on it, so no service is lost

Because of this possibility of being raised at two different levels, the alarm profile pane shows Critical as CR / MN and Major as MJ / MN.

14.5 Alarm Profiles

The alarm profiles feature allows you to change default alarm severities by creating unique alarm profiles for individual ONS 15454 ports, cards, or nodes. A created alarm profile can be applied to any node on the network. Alarm profiles can be saved to a file and imported elsewhere in the network, but the profile must be stored locally on a node before it can be applied to the node, its cards, or its cards' ports.

CTC can store up to ten active alarm profiles at any time to apply to the node. Custom profiles can take eight of these active profile positions. Two other profiles, Default profile and Inherited profile, are reserved by the NE, and cannot be edited. The reserved Default profile contains Telcordia GR-474 severities. The reserved Inherited profile allows port alarm severities to be governed by the card-level severities, or card alarm severities to be determined by the node-level severities.

If one or more alarm profiles have been stored as files from elsewhere in the network onto the local PC or server hard drive where CTC resides, you can use as many profiles as you can physically store by deleting and replacing them locally in CTC so that only eight are active at any given time.

14.5.1 Creating and Modifying Alarm Profiles

Alarm profiles are created in the network view using the Provisioning > Alarm Profiles tabs. Figure 14-3 shows the default list of alarm severities. A default alarm severity following Telcordia GR-253 standards is preprovisioned for every alarm. After loading the default profile or another profile on the node, you can clone a profile to create custom profiles. After the new profile is created, the Alarm Profiles window shows the original profile (frequently Default) and the new profile.

Figure 14-3 Network View Alarm Profiles Window

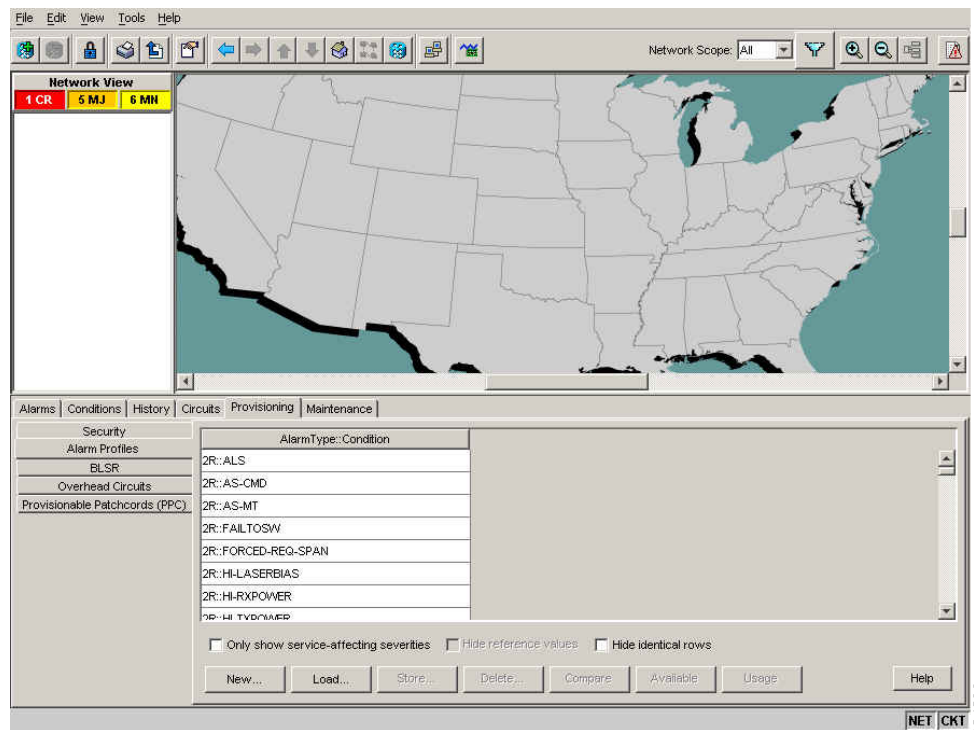

The alarm profile list contains a master list of alarms that is used for a mixed node network. Some of these alarms might not be used in all ONS nodes.



Tip

To see the full list of profiles including those available for loading or cloning, click the Available button. You must load a profile before you can clone it.

**Note**

Up to 10 profiles, including the two reserved profiles (Inherited and Default) can be stored in CTC.

Wherever it is applied, the Default alarm profile sets severities to standard Telcordia GR-253 settings. In the Inherited profile, alarms inherit, or copy, severity from the next-highest level. For example, a card with an Inherited alarm profile copies the severities used by the node housing the card. If you choose the Inherited profile from the network view, the severities at the lower levels (node and card) are copied from this selection.

You do not have to apply a single severity profile to the node, card, and port alarms. Different profiles can be applied at different levels. You could use the inherited or default profile on a node and on all cards and ports, but apply a custom profile that downgrades an alarm on one particular card. For example, you might choose to downgrade an OC-N unequipped path alarm (UNEQ-P) from Critical (CR) to Not Alarmed (NA) on an optical card because this alarm raises and then clears every time you create a circuit. UNEQ-P alarms for the card with the custom profile would not display on the Alarms tab. (But they would still be recorded on the Conditions and History tabs.)

When you modify severities in an alarm profile:

- All Critical (CR) or Major (MJ) default or user-defined severity settings are demoted to Minor (MN) in Non-Service-Affecting (NSA) situations as defined in Telcordia GR-474.
- Default severities are used for all alarms and conditions until you create a new profile and apply it.

The Load and Store buttons are not available for Retrieve and Maintenance users.

The Delete and Store options will only display nodes to delete profiles from or store profiles to if the user has provisioning permission for those nodes. If the user does not have the proper permissions, CTC greys out the buttons and they are not available to the user.

14.5.2 Alarm Profile Buttons

The Alarm Profiles window displays six buttons at the bottom of the window. [Table 14-7](#) lists and describes each of the alarm profile buttons and their functions.

Table 14-7 Alarm Profile Buttons

Button	Description
New	Creates a new profile.
Load	Loads a profile to a node or a file.
Store	Saves profiles on a node (or nodes) or in a file.
Delete	Deletes profiles from a node.
Compare	Displays differences between alarm profiles (for example, individual alarms that are not configured equivalently between profiles).
Available	Displays all profiles available on each node.
Usage	Displays all entities (nodes and alarm subjects) present in the network and which profiles contain the alarm. Can be printed.

14.5.3 Alarm Profile Editing

Table 14-8 lists and describes the five profile-editing options available when you right-click an alarm item in the profile column.

Table 14-8 Alarm Profile Editing Options

Button	Description
Store	Saves a profile in a node or in a file.
Rename	Changes a profile name.
Clone	Creates a profile that contains the same alarm severity settings as the profile being cloned.
Reset	Restores a profile to its previous state or to the original state (if it has not yet been applied).
Remove	Removes a profile from the table editor.

14.5.4 Alarm Severity Options

To change or assign alarm severity, left-click the alarm severity you want to change in the alarm profile column. Seven severity levels appear for the alarm:

- Not Reported (NR)
- Not Alarmed (NA)
- Minor (MN)
- Major (MJ)
- Critical (CR)
- Use Default
- Inherited

Inherited and Use Default severity levels only appear in alarm profiles. They do not appear when you view alarms, history, or conditions.

14.5.5 Row Display Options

The Alarm Profiles window (from network view) or the Alarm Profile Editor (from node view) displays three check boxes at the bottom of the window:

- Only show service-affecting severities—If unchecked, the editor shows severities in the format <sev1>/<sev2> where <sev1> is a service-affecting severity and <sev2> is not service-affecting. If checked, the editor only shows <sev1> alarms.
- Hide reference values—Highlights alarms with non-default severities by clearing alarm cells with default severities. This check-box is normally greyed out. It becomes active only when more than one profile is listed in the Alarm Profile Editor window. (The check box text changes to “Hide Values matching profile Default” in this case.)
- Hide identical rows—Hides rows of alarms that contain the same severity for each profile.

14.5.6 Applying Alarm Profiles

In CTC node view, the Alarm Behavior window displays alarm profiles for the node. In card view, the Alarm Behavior window displays the alarm profiles for the selected card. Alarm profiles form a hierarchy. A node-level alarm profile applies to all cards in the node except cards that have their own profiles. A card-level alarm profile applies to all ports on the card except ports that have their own profiles.

At the node level, you can apply profile changes on a card-by-card basis or set a profile for the entire node. At the card-level view, you can apply profile changes on a port-by-port basis or set alarm profiles for all ports on that card. [Figure 14-4](#) shows the DS1 card alarm profile.

Figure 14-4 DS1 Card Alarm Profile

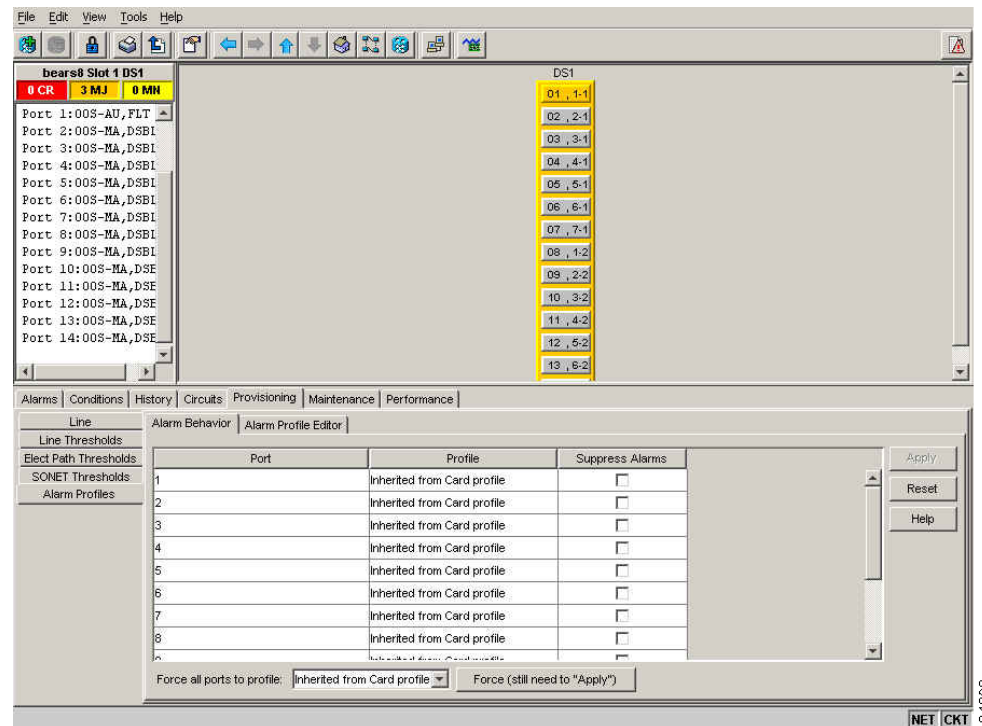

14.6 Alarm Suppression

The following sections explain alarm suppression features for the ONS 15454.

14.6.1 Alarms Suppressed for Maintenance

When you place a port in OOS,MT administrative state, this raises the alarm suppressed for maintenance (AS-MT) alarm in the Conditions and History windows¹ and causes subsequently raised alarms for that port to be suppressed.

1. AS-MT can be seen in the Alarms window as well if you have set the Filter dialog box to show NA severity events.

While the facility is in the OOS,MT state, any alarms or conditions that are raised and suppressed on it (for example, a transmit failure [TRMT] alarm) are reported in the Conditions window and show their normal severity in the Sev column. The suppressed alarms are not shown in the Alarms and History windows. (These windows only show AS-MT). When you place the port back into IS,AINS administrative state, the AS-MT alarm is resolved in all three windows. Suppressed alarms remain raised in the Conditions window until they are cleared.

14.6.2 Alarms Suppressed by User Command

In the Provisioning > Alarm Profiles > Alarm Behavior tabs, the ONS 15454 has an alarm suppression option that clears raised alarm messages for the node, chassis, one or more slots (cards), or one or more ports. Using this option raises the alarms suppressed by user command, or AS-CMD alarm. The AS-CMD alarm, like the AS-MT alarm, appears in the Conditions, and History¹ windows. Suppressed conditions (including alarms) appear only in the Conditions window--showing their normal severity in the Sev column. When the Suppress Alarms check box is unchecked, the AS-CMD alarm is cleared from all three windows.

A suppression command applied at a higher level does not supersede a command applied at a lower level. For example, applying a node-level alarm suppression command makes all raised alarms for the node appear to be cleared, but it does not cancel out card-level or port-level suppression. Each of these conditions can exist independently and must be cleared independently.



Caution

Use alarm suppression with caution. If multiple CTC or TL1 sessions are open, suppressing the alarms in one session suppresses the alarms in all other open sessions.

14.7 External Alarms and Controls

External alarm inputs can be provisioned on the Alarm Interface Controller-International (AIC-I) card for external sensors such as an open door and flood sensors, temperature sensors, and other environmental conditions. External control outputs on these two cards allow you to drive external visual or audible devices such as bells and lights. They can control other devices such as generators, heaters, and fans.

You provision external alarms in the AIC-I card view Provisioning > External Alarms tab and controls in the AIC-I card view Provisioning > External Controls tab. Up to 12 external alarm inputs and four external controls are available. If you also provision the alarm extension panel (AEP), there are 32 inputs and 16 outputs.

14.7.1 External Alarms

You can provision each alarm input separately. Provisionable characteristics of external alarm inputs include:

- Alarm Type—List of alarm types.
- Severity—CR, MJ, MN, NA, and NR.
- Virtual Wire—The virtual wire associated with the alarm.

- Raised When—Open means that the normal condition is to not have current flowing through the contact, and the alarm is generated when current does flow; closed means that the normal condition is to have current flowing through the contact, and the alarm is generated when current stops flowing.
- Description—CTC alarm log description (up to 63 characters).

**Note**

If you provision an external alarm to raise when a contact is open, and you have not attached the alarm cable, the alarm will remain raised until the alarm cable is connected.

**Note**

When you provision an external alarm, the alarm object is ENV-IN-*nn*. The variable *nn* refers to the external alarm's number, regardless of the name you assign.

14.7.2 External Controls

You can provision each alarm output separately. Provisionable characteristics of alarm outputs include:

- Control type.
- Trigger type (alarm or virtual wire).
- Description for CTC display.
- Closure setting (manually or by trigger). If you provision the output closure to be triggered, the following characteristics can be used as triggers:
 - Local NE alarm severity—A chosen alarm severity (for example, major) and any higher-severity alarm (in this case, critical) causes output closure.
 - Remote NE alarm severity—Similar to local NE alarm severity trigger setting, but applies to remote alarms.
 - Virtual wire entities—You can provision an alarm that is input to a virtual wire to trigger an external control output.



CHAPTER 15

Performance Monitoring

Performance monitoring (PM) parameters are used by service providers to gather, store, set thresholds for, and report performance data for early detection of problems. In this chapter, PM parameters and concepts are defined for electrical cards, Ethernet cards, optical cards, optical multirate cards, and storage access networking (SAN) cards in the Cisco ONS 15454.

For information about enabling and viewing PM values, refer to the *Cisco ONS 15454 Procedure Guide*.

Chapter topics include:

- [15.1 Threshold Performance Monitoring, page 15-1](#)
- [15.2 Intermediate Path Performance Monitoring, page 15-3](#)
- [15.3 Pointer Justification Count Performance Monitoring, page 15-4](#)
- [15.4 Performance Monitoring Parameter Definitions, page 15-4](#)
- [15.5 Performance Monitoring for Electrical Cards, page 15-12](#)
- [15.6 Performance Monitoring for Ethernet Cards, page 15-29](#)
- [15.7 Performance Monitoring for Optical Cards, page 15-42](#)
- [15.8 Performance Monitoring for Optical Multirate Cards, page 15-44](#)
- [15.9 Performance Monitoring for Storage Access Networking Cards, page 15-45](#)



Note

For transponder (TXP), and muxponder (TXP), and DWDM card PM parameters, refer to the *Cisco ONS 15454 DWDM Reference Manual*.



Note

For additional information regarding PM parameters, refer to Telcordia documents GR-1230-CORE, GR-820-CORE, GR-499-CORE, and GR-253-CORE and the ANSI T1.231 document entitled *Digital Hierarchy - Layer 1 In-Service Digital Transmission Performance Monitoring*.

15.1 Threshold Performance Monitoring

Thresholds are used to set error levels for each PM parameter. You can set individual PM threshold values from the Cisco Transport Controller (CTC) card view Provisioning tab. For procedures on provisioning card thresholds, such as line, path, and SONET thresholds, refer to the *Cisco ONS 15454 Procedure Guide*.

During the accumulation cycle, if the current value of a PM parameter reaches or exceeds its corresponding threshold value, a threshold crossing alert (TCA) is generated by the node and displayed by CTC. TCAs provide early detection of performance degradation. When a threshold is crossed, the node continues to count the errors during a given accumulation period. If zero is entered as the threshold value, generation of TCAs is disabled, but performance monitoring continues.

Change the threshold if the default value does not satisfy your error monitoring needs. For example, customers with a critical DS-1 installed for 911 calls must guarantee the best quality of service on the line; therefore, they lower all thresholds so that the slightest error raises a TCA.

When TCAs occur, they appear in CTC. An example is T-UASP-P in the **Cond** column (shown in Figure 15-1), where the “T-” indicates a threshold crossing. For certain electrical cards, “RX” or “TX” is appended to the TCA description, as indicated by the red circles in Figure 15-1. The RX indicates that the TCA is associated with the receive direction, and TX indicates that the TCA is associated with the transmit direction.

Figure 15-1 TCAs Displayed in CTC

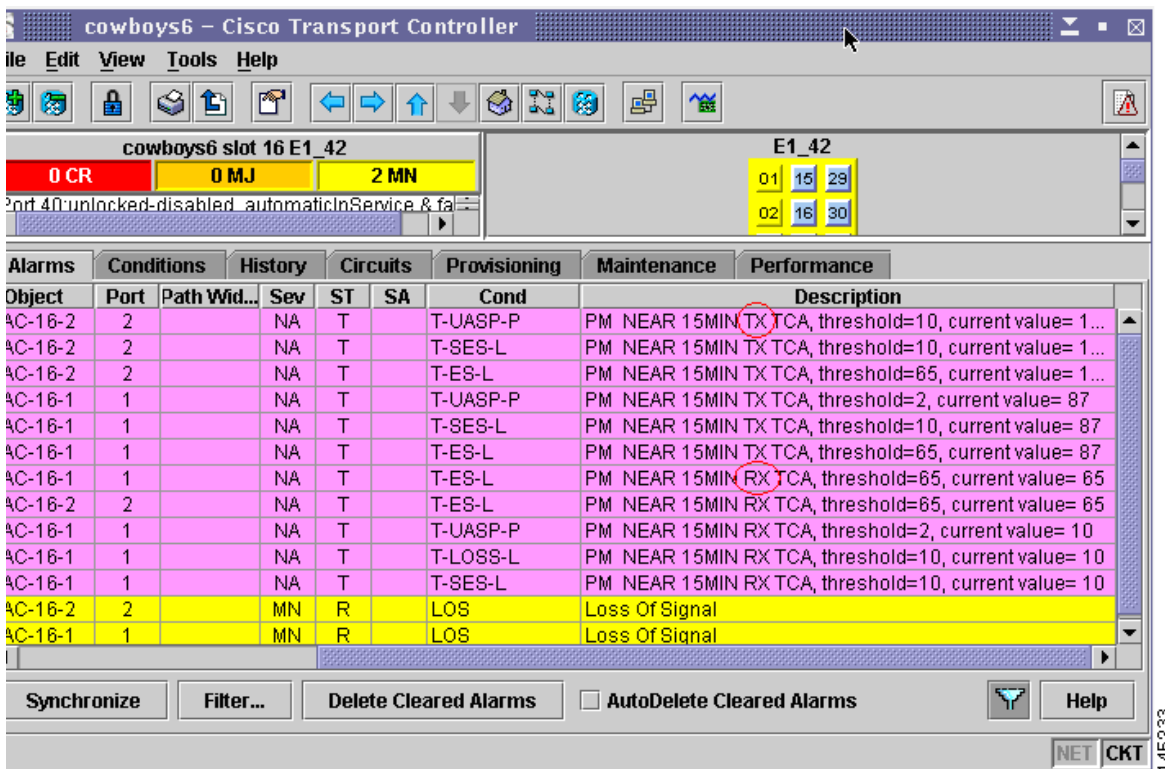

Table 15-1 shows the electrical cards for which RX and TX are appended to the TCA descriptions.

Table 15-1 Electrical Cards that Report RX and TX Direction for TCAs

Card	Line				Path			
	Near End		Far End		Near End		Far End	
	RX	TX	RX	TX	RX	TX	RX	TX
DS1-14	YES	—	YES	—	YES	YES	YES	—
DS1N-14	YES	—	YES	—	YES	YES	YES	—

Due to memory limitations and the number of TCAs generated by different platforms, you can manually add/modify the following two properties to the platform property file (CTC.INI for Windows and .ctcr for UNIX):

- **ctc.15xxx.node.tr.lowater=yyy** where xxx is the platform and yyy is the number of the lowater mark. The default lowater mark is 25.
- **ctc.15xxx.node.tr.hiwater=yyy** where xxx is the platform and yyy is the number of the hiwater mark. The default hiwater mark is 50.

If the number of the incoming TCA is greater than the hiwater mark, the node will keep the latest lowater mark and discard older ones.

15.2 Intermediate Path Performance Monitoring

Intermediate path performance monitoring (IPPM) allows transparent monitoring of a constituent channel of an incoming transmission signal by a node that does not terminate that channel. Many large networks only use line terminating equipment (LTE), not path terminating equipment (PTE). [Table 15-2](#) shows ONS 15454 cards that are considered LTE.

Table 15-2 ONS 15454 Line Terminating Equipment

ONS 15454 Electrical LTE	
EC1-12 card	
ONS 15454 Optical LTE	
OC3 IR 4/STM1 SH 1310	OC3 IR/STM1 SH 1310-8
OC12 IR/STM4 SH1310	OC12 LR/STM4 LH1310
OC12 LR/STM4 LH 1550	OC12 IR/STM4 SH 1310-4
OC48 IR 1310 ¹	OC48 LR 1550
OC48 IR/STM16 SH AS 1310 ¹	OC48 LR/STM16 LH AS 1550
OC48 ELR/STM16 EH 100 GHz	OC48 ELR 200 GHz
OC192 SR/STM64 IO 1310	OC192 IR/STM64 SH 1550
OC192 LR/STM64 LH 1550	OC192 LR/STM64 LH ITU 15xx.xx
TXP_MR_10G	MXP_2.5G_10G
MXP_MR_2.5G	MXPP_MR_2.5G

1. An OC-48 IR card used in a bidirectional line switched ring (BLSR) does not support IPPM during a protection switch.

ONS 15454 Software R3.0 and higher allows LTE cards to monitor near-end PM data on individual synchronous transport signal (STS) payloads by enabling IPPM. After enabling IPPM provisioning on the line card, service providers can monitor large amounts of STS traffic through intermediate nodes, thus making troubleshooting and maintenance activities more efficient.

IPPM occurs only on STS paths that have IPPM enabled, and TCAs are raised only for PM parameters on the IPPM enabled paths. The monitored IPPM parameters are STS CV-P, STS ES-P, STS SES-P, STS UAS-P, and STS FC-P.

**Note**

Far-end IPPM is not supported by all OC-N cards. It is supported by OC3-4 and EC-1 cards. However, SONET path PMs can be monitored by logging into the far-end node directly.

The ONS 15454 performs IPPM by examining the overhead in the monitored path and by reading all of the near-end path PM values in the incoming direction of transmission. The IPPM process allows the path signal to pass bidirectionally through the node completely unaltered.

See [Table 15-3 on page 15-5](#) for detailed information and definitions of specific IPPM parameters.

15.3 Pointer Justification Count Performance Monitoring

Pointers are used to compensate for frequency and phase variations. Pointer justification counts indicate timing errors on SONET networks. When a network is out of synchronization, jitter and wander occur on the transported signal. Excessive wander can cause terminating equipment to slip.

Slips cause different effects in service. Voice service has intermittent audible clicks. Compressed voice technology has short transmission errors or dropped calls. Fax machines lose scanned lines or experience dropped calls. Digital video transmission has distorted pictures or frozen frames. Encryption service loses the encryption key, causing data to be transmitted again.

Pointers provide a way to align the phase variations in STS and VT payloads. The STS payload pointer is located in the H1 and H2 bytes of the line overhead. Clocking differences are measured by the offset in bytes from the pointer to the first byte of the STS synchronous payload envelope (SPE) called the J1 byte. Clocking differences that exceed the normal range of 0 to 782 can cause data loss.

There are positive (PPJC) and negative (NPJC) pointer justification count parameters. PPJC is a count of path-detected (PPJC-PDET-P) or path-generated (PPJC-PGEN-P) positive pointer justifications. NPJC is a count of path-detected (NPJC-PDET-P) or path-generated (NPJC-PGEN-P) negative pointer justifications depending on the specific PM name. PJCDIFF is the absolute value of the difference between the total number of detected pointer justification counts and the total number of generated pointer justification counts. PJCS-PDET-P is a count of the one-second intervals containing one or more PPJC-PDET or NPJC-PDET. PJCS-PGEN-P is a count of the one-second intervals containing one or more PPJC-PGEN or NPJC-PGEN.

A consistent pointer justification count indicates clock synchronization problems between nodes. A difference between the counts means that the node transmitting the original pointer justification has timing variations with the node detecting and transmitting this count. Positive pointer adjustments occur when the frame rate of the SPE is too slow in relation to the rate of the STS-1.

You must enable PPJC and NPJC performance monitoring parameters for LTE cards. See [Table 15-2 on page 15-3](#) for a list of Cisco ONS 15454 LTE cards. In CTC, the count fields for PPJC and NPJC PMs appear white and blank unless they are enabled on the card view Provisioning tab.

See [Table 15-3 on page 15-5](#) for detailed information and definitions of specific pointer justification count PM parameters.

15.4 Performance Monitoring Parameter Definitions

[Table 15-3](#) gives definitions for each type of PM parameter found in this chapter.

Table 15-3 Performance Monitoring Parameters

Parameter	Definition
AISS-P	AIS Seconds Path (AISS-P) is a count of one-second intervals containing one or more alarm indication signal (AIS) defects.
BBE-PM	Path Monitoring Background Block Errors (BBE-PM) indicates the number of background block errors recorded in the optical transport network (OTN) path during the PM time interval.
BBE-SM	Section Monitoring Background Block Errors (BBE-SM) indicates the number of background block errors recorded in the OTN section during the PM time interval.
BBER-PM	Path Monitoring Background Block Errors Ratio (BBER-PM) indicates the background block errors ratio recorded in the OTN path during the PM time interval.
BBER-SM	Section Monitoring Background Block Errors Ratio (BBER-SM) indicates the background block errors ratio recorded in the OTN section during the PM time interval.
BIT-EC	Bit Errors Corrected (BIT-EC) indicated the number of bit errors corrected in the DWDM trunk line during the PM time interval.
CSS	Controlled Slip Seconds (CSS) indicates the count of the seconds when at least one or more controlled slips have occurred.
CSS-P	Controlled Slip Seconds Path (CSS-P) indicates the count of the seconds when at least one or more controlled slips have occurred.
CVCP-P	Code Violation CP-bit Path (CVCP-P) is a count of CP-bit parity errors occurring in the accumulation period.
CVCP-PFE	Code Violation CP-bit Path (CVCP-PFE) is a parameter that is counted when the three far-end block error (FEBE) bits in an M-frame are not all collectively set to 1.
CGV	Code Group Violations (CGV) is a count of received code groups that do not contain a start or end delimiter.
CV-L	Line Code Violation (CV-L) indicates the number of coding violations occurring on the line. This parameter is a count of bipolar violations (BPVs) and excessive zeros (EXZs) occurring over the accumulation period.
CV-P	Near-End STS Path Coding Violations (CV-P) is a count of BIP errors detected at the STS path layer (that is, using the B3 byte). Up to eight BIP errors can be detected per frame; each error increments the current CV-P second register.
CV-PFE	Far-End STS Path Coding Violations (CV-PFE) is a count of BIP errors detected at the STS path layer (that is, using the B3 byte). Up to eight BIP errors can be detected per frame; each error increments the current CV-PFE second register.
CVP-P	Code Violation Path (CVP-P) is a code violation parameter for M23 applications. CVP-P is a count of P-bit parity errors occurring in the accumulation period.

Table 15-3 Performance Monitoring Parameters (continued)

Parameter	Definition
CV-S	Section Coding Violation (CV-S) is a count of bit interleaved parity (BIP) errors detected at the section layer (that is, using the B1 byte in the incoming SONET signal). Up to eight section BIP errors can be detected per STS-N frame; each error increments the current CV-S second register.
CV-V	Code Violation VT Layer (CV-V) is a count of the BIP errors detected at the VT path layer. Up to two BIP errors can be detected per VT superframe, with each error incrementing the current CV-V second register.
DCG	Data Code Groups (DCG) is a count of received data code groups that do not contain ordered sets.
ESA-P	Path Errored Seconds-A (ESA-P) is the count of 1-second intervals with exactly one CRC-6 error and no AIS or severely errored framing (SEF) defects.
ESB-P	Path Errored Seconds-B (Rx ESB-P) is a count of 1-second intervals with between 2 and 319 CRC-6 errors and no AIS or SEF.
ESCP-P	Errored Seconds CP-bit Path (ESCP-P) is a count of seconds containing one or more CP-bit parity errors, one or more SEF defects, or one or more AIS defects. ESCP-P is defined for the C-bit parity application.
ESCP-PFE	Far-End Errored Seconds CP-bit Path (ESCP-PFE) is a count of one-second intervals containing one or more M-frames with the three FEBE bits not all collectively set to 1 or one or more far-end SEF/AIS defects.
ES-L	Line Errored Seconds (ES-L) is a count of the seconds containing one or more anomalies (BPV + EXZ) and/or defects (that is, loss of signal) on the line.
ES-NP	
ES-P	Near-End STS Path Errored Seconds (ES-P) is a count of the seconds when at least one STS path BIP error was detected. An AIS Path (AIS-P) defect (or a lower-layer, traffic-related, near-end defect) or a Loss of Pointer Path (LOP-P) defect can also cause an ES-P.
ES-PFE	Far-End STS Path Errored Seconds (ES-PFE) is a count of the seconds when at least one STS path BIP error was detected. An AIS-P defect (or a lower-layer, traffic-related, far-end defect) or an LOP-P defect can also cause an STS ES-PFE.
ES-PM	Path Monitoring Errored Seconds (ES-PM) indicates the errored seconds recorded in the OTN path during the PM time interval.
ESP-P	Errored Seconds Path (ESP-P) is a count of seconds containing one or more P-bit parity errors, one or more SEF defects, or one or more AIS defects.
ESR-PM	Path Monitoring Errored Seconds Ratio (ESR-PM) indicates the errored seconds ratio recorded in the OTN path during the PM time interval.
ESR-SM	Section Monitoring Errored Seconds Ratio (ESR-SM) indicates the errored seconds ratio recorded in the OTN section during the PM time interval.

Table 15-3 Performance Monitoring Parameters (continued)

Parameter	Definition
ES-S	Section Errored Seconds (ES-S) is a count of the number of seconds when at least one section-layer BIP error was detected or an SEF or loss of signal (LOS) defect was present.
ES-SM	Section Monitoring Errored Seconds (ES-SM) indicates the errored seconds recorded in the OTN section during the PM time interval.
ES-V	Errored Seconds VT Layer (ES-V) is a count of the seconds when at least one VT Path BIP error was detected. An AIS Virtual Tributary (VT) (AIS-V) defect (or a lower-layer, traffic-related, near-end defect) or an LOP VT (LOP-V) defect can also cause an ES-V.
FC-L	Line Failure Count (FC-L) is a count of the number of near-end line failure events. A failure event begins when an AIS Line (AIS-L) failure is declared or when a lower-layer, traffic-related, near-end failure is declared. This failure event ends when the failure is cleared. A failure event that begins in one period and ends in another period is counted only in the period where it begins.
FC-P	Near-End STS Path Failure Counts (FC-P) is a count of the number of near-end STS path failure events. A failure event begins when an AIS-P failure, an LOP-P failure, a UNEQ-P failure, or a Section Trace Identifier Mismatch Path (TIM-P) failure is declared. A failure event also begins if the STS PTE that is monitoring the path supports Three-Bit (Enhanced) Remote Failure Indication Path Connectivity (ERFI-P-CONN) for that path. The failure event ends when these failures are cleared.
FC-PFE	Far-End STS Path Failure Counts (FC-PFE) is a count of the number of near-end STS path failure events. A failure event begins when an AIS-P failure, an LOP-P failure, a UNEQ-P failure, or a TIM-P failure is declared. A failure event also begins if the STS PTE that is monitoring the path supports ERFI-P-CONN for that path. The failure event ends when these failures are cleared.
FC-PM	Path Monitoring Failure Counts (FC-PM) indicates the failure counts recorded in the OTN path during the PM time interval.
FC-SM	Section Monitoring Failure Counts (FC-SM) indicates the failure counts recorded in the OTN section during the PM time interval.
IOS	Idle Ordered Sets (IOS) is a count of received packets containing idle ordered sets.
IPC	Invalid Packets (IPC) is the count of received packets that contain errored data code groups that have start and end delimiters.
LBCL-MIN	Laser Bias Current Line—Minimum (LBCL-MIN) is the minimum percentage of laser bias current.
LBCL-AVG	Laser Bias Current Line—Average (LBCL-AVG) is the average percentage of laser bias current.
LBCL-MAX	Laser Bias Current Line—Maximum (LBCL-MAX) is the maximum percentage of laser bias current.
LOFC	Loss of Frame Count (LOFC)

Table 15-3 Performance Monitoring Parameters (continued)

Parameter	Definition
LOSS-L	Line Loss of Signal (LOSS-L) is a count of one-second intervals containing one or more LOS defects.
NIOS	Non-Idle Ordered Sets (NIOS) is a count of received packets containing non-idle ordered sets.
NPJC-PDET	Negative Pointer Justification Count, STS Detected (NPJC-PDET), formerly Pointer Justification Negative (PJNEG)
NPJC-PDET-P	Negative Pointer Justification Count, STS Path Detected (NPJC-PDET-P) is a count of the negative pointer justifications detected on a particular path in an incoming SONET signal.
NPJC-PGEN-P	Negative Pointer Justification Count, STS Path Generated (NPJC-PGEN-P) is a count of the negative pointer justifications generated for a particular path to reconcile the frequency of the SPE with the local clock.
OPR	Optical Power Received (OPR) is the measure of average optical power received as a percentage of the nominal OPR.
OPR-AVG	Average Receive Optical Power (dBm)
OPR-MAX	Maximum Receive Optical Power (dBm)
OPR-MIN	Minimum Receive Optical Power (dBm)
OPT	Optical Power Transmitted (OPT) is the measure of average optical power transmitted as a percentage of the nominal OPT.
OPT-AVG	Average Transmit Optical Power (dBm)
OPT-MAX	Maximum Transmit Optical Power (dBm)
OPT-MIN	Minimum Transmit Optical Power (dBm)
OPWR-AVG	Optical Power - Average (OPWR-AVG) is the measure of average optical power on the unidirectional port.
OPWR-MAX	Optical Power - Maximum (OPWR-MAX) is the measure of maximum value of optical power on the unidirectional port.
OPWR-MIN	Optical Power - Minimum (OPWR-MIN) is the measure of minimum value of optical power on the unidirectional port.
PJCDIFF-P	Pointer Justification Count Difference, STS Path (PJCDIFF-P) is the absolute value of the difference between the total number of detected pointer justification counts and the total number of generated pointer justification counts. That is, PJCDiff-P is equal to (PPJC-PGEN-P – NPJC-PGEN-P) – (PPJC-PDET-P – NPJC-PDET-P).
PPJC-PDET	Pointer Justification STS Detected (PPJC-PDET), formerly Pointer Justification Positive (PJPOS).
PPJC-PDET-P	Positive Pointer Justification Count, STS Path Detected (PPJC-PDET-P) is a count of the positive pointer justifications detected on a particular path in an incoming SONET signal.
PPJC-PGEN-P	Positive Pointer Justification Count, STS Path Generated (PPJC-PGEN-P) is a count of the positive pointer justifications generated for a particular path to reconcile the frequency of the SPE with the local clock.

Table 15-3 Performance Monitoring Parameters (continued)

Parameter	Definition
PJCS-PDET-P	Pointer Justification Count Seconds, STS Path Detect (NPJCS-PDET-P) is a count of the one-second intervals containing one or more PPJC-PDET or NPJC-PDET.
PJCS-PGEN-P	Pointer Justification Count Seconds, STS Path Generate (PJCS-PGEN-P) is a count of the one-second intervals containing one or more PPJC-PGEN or NPJC-PGEN.
PSC	In a 1 + 1 protection scheme for a working card, Protection Switching Count (PSC) is a count of the number of times service switches from a working card to a protection card plus the number of times service switches back to the working card. For a protection card, PSC is a count of the number of times service switches to a working card from a protection card plus the number of times service switches back to the protection card. The PSC PM parameter is only applicable if revertive line-level protection switching is used.
PSC-R	In a four-fiber bidirectional line switched ring (BLSR), Protection Switching Count-Ring (PSC-R) is a count of the number of times service switches from a working line to a protection line plus the number of times it switches back to a working line. A count is only incremented if ring switching is used.
PSC-S	In a four-fiber BLSR, Protection Switching Count-Span (PSC-S) is a count of the number of times service switches from a working line to a protection line plus the number of times it switches back to the working line. A count is only incremented if span switching is used.
PSC-W	For a working line in a two-fiber BLSR, Protection Switching Count-Working (PSC-W) is a count of the number of times traffic switches away from the working capacity in the failed line and back to the working capacity after the failure is cleared. PSC-W increments on the failed working line and PSC increments on the active protect line. For a working line in a four-fiber BLSR, PSC-W is a count of the number of times service switches from a working line to a protection line plus the number of times it switches back to the working line. PSC-W increments on the failed line and PSC-R or PSC-S increments on the active protect line.
PSD	Protection Switching Duration (PSD) applies to the length of time, in seconds, that service is carried on another line. For a working line, PSD is a count of the number of seconds that service was carried on the protection line. For the protection line, PSD is a count of the seconds that the line was used to carry service. The PSD PM is only applicable if revertive line-level protection switching is used.
PSD-R	In a four-fiber BLSR, Protection Switching Duration-Ring (PSD-R) is a count of the seconds that the protection line was used to carry service. A count is only incremented if ring switching is used.

Table 15-3 Performance Monitoring Parameters (continued)

Parameter	Definition
PSD-S	In a four-fiber BLSR, Protection Switching Duration-Span (PSD-S) is a count of the seconds that the protection line was used to carry service. A count is only incremented if span switching is used.
SASCP-P	SEF/AIS Seconds CP-bit Path (SASCP-P) is a count of one-second intervals containing one or more SEFs or one or more AIS defects on the path.
SASP	SEF/AIS Seconds (SASP) is a count of one-second intervals containing one or more SEFs or one or more AIS defects on the path.
SASP-P	SEF/AIS Seconds Path (SASP-P) is a count of one-second intervals containing one or more SEFs or one or more AIS defects on the path.
SEF-S	Severely Errored Framing Seconds (SEFS-S) is a count of the seconds when an SEF defect was present. An SEF defect is expected to be present during most seconds when an LOS or loss of frame (LOF) defect is present. However, there can be situations when the SEFS-S parameter is only incremented based on the presence of the SEF defect.
SESCP-P	Severely Errored Seconds CP-bit Path (SESCP-P) is a count of seconds containing more than 44 CP-bit parity errors, one or more SEF defects, or one or more AIS defects.
SESCP-PFE	Severely Errored Seconds CP-bit Path (SESCP-PFE) is a count of one-second intervals containing one or more far-end SEF/AIS defects, or one or more 44 M-frames with the three FEBE bits not all collectively set to 1.
SES-L	Line Severely Errored Seconds (SES-L) is a count of the seconds containing more than a particular quantity of anomalies ($BPV + EXZ \geq 44$) and/or defects on the line.
SES-P	Near-End STS Path Severely Errored Seconds (SES-P) is a count of the seconds when K (2400) or more STS path BIP errors were detected. An AIS-P defect (or a lower-layer, traffic-related, near-end defect) or an LOP-P defect can also cause an SES-P.
SES-PFE	Far-End STS Path Severely Errored Seconds (SES-PFE) is a count of the seconds when K (2400) or more STS path BIP errors were detected. An AIS-P defect (or a lower-layer, traffic-related, far-end defect) or an LOP-P defect can also cause an SES-PFE.
SES-PM	Path Monitoring Severely Errored Seconds (SES-PM) indicates the severely errored seconds recorded in the OTN path during the PM time interval.
SESP-P	Severely Errored Seconds Path (SESP-P) is a count of seconds containing more than 44 P-bit parity violations, one or more SEF defects, or one or more AIS defects.
SES-S	Section Severely Errored Seconds (SES-S) is a count of the seconds when K (see Telcordia GR-253 for value) or more section-layer BIP errors were detected or an SEF or LOS defect was present.
SES-SM	Section Monitoring Severely Errored Seconds (SES-SM) indicates the severely errored seconds recorded in the OTN section during the PM time interval.

Table 15-3 Performance Monitoring Parameters (continued)

Parameter	Definition
SESR-PM	Path Monitoring Severely Errored Seconds Ratio (SESR-PM) indicates the severely errored seconds ratio recorded in the OTN path during the PM time interval.
SESR-SM	Section Monitoring Severely Errored Seconds Ratio (SESR-SM) indicates the severely errored seconds ratio recorded in the OTN section during the PM time interval.
SES-V	Severely Errored Seconds VT Layer (SES-V) is a count of seconds when K (600) or more VT Path BIP errors were detected. An AIS-V defect (or a lower-layer, traffic-related, near-end defect) or an LOP-V defect can also cause SES-V.
UAS-L	Line Unavailable Seconds (UAS-L) is a count of the seconds when the line is unavailable. A line becomes unavailable when ten consecutive seconds occur that qualify as SES-Ls, and it continues to be unavailable until ten consecutive seconds occur that do not qualify as SES-Ls.
UASCP-P	Unavailable Seconds CP-bit Path (UASCP-P) is a count of one-second intervals when the DS-3 path is unavailable. A DS-3 path becomes unavailable when ten consecutive SESCO-Ps occur. The ten SESCO-Ps are included in unavailable time. After the DS-3 path becomes unavailable, it becomes available again when ten consecutive seconds with no SESCO-Ps occur. The ten seconds with no SESCO-Ps are excluded from unavailable time.
UASCP-PFE	Unavailable Seconds CP-bit Path (UASCP-PFE) is a count of one-second intervals when the DS-3 path becomes unavailable. A DS-3 path becomes unavailable when ten consecutive far-end CP-bit SESs occur. The ten CP-bit SESs are included in unavailable time. After the DS-3 path becomes unavailable, it becomes available again when ten consecutive seconds occur with no CP-bit SESs. The ten seconds with no CP-bit SESs are excluded from unavailable time.
UAS-P	Near-End STS Path Unavailable Seconds (UAS-P) is a count of the seconds when the STS path was unavailable. An STS path becomes unavailable when ten consecutive seconds occur that qualify as SES-Ps, and continues to be unavailable until ten consecutive seconds occur that do not qualify as SES-Ps.
UAS-PFE	Far-End STS Path Unavailable Seconds (UAS-PFE) is a count of the seconds when the STS path was unavailable. An STS path becomes unavailable when ten consecutive seconds occur that qualify as SES-PFEs, and continues to be unavailable until ten consecutive seconds occur that do not qualify as SES-PFEs.
UAS-PM	Path Monitoring Unavailable Seconds (UAS-PM) indicates the unavailable seconds recorded in the OTN path during the PM time interval.

Table 15-3 Performance Monitoring Parameters (continued)

Parameter	Definition
UASP-P	Unavailable Seconds Path (UASP-P) is a count of one-second intervals when the DS-3 path is unavailable. A DS-3 path becomes unavailable when ten consecutive SESP-Ps occur. The ten SESP-Ps are included in unavailable time. After the DS-3 path becomes unavailable, it becomes available again when ten consecutive seconds with no SESP-Ps occur. The ten seconds with no SESP-Ps are excluded from unavailable time.
UAS-SM	Section Monitoring Unavailable Seconds (UAS-SM) indicates the unavailable seconds recorded in the OTN section during the PM time interval.
UAS-V	Unavailable Seconds VT Layer (UAS-V) is a count of the seconds when the VT path was unavailable. A VT path becomes unavailable when ten consecutive seconds occur that qualify as SES-Vs, and it continues to be unavailable until ten consecutive seconds occur that do not qualify as SES-Vs.
UNC-WORDS	Uncorrectable Words (UNC-WORDS) is the number of uncorrectable words detected in the DWDM trunk line during the PM time interval.
VPC	Valid Packets (VPC) is a count of received packets that contain non-errored data code groups that have start and end delimiters.

15.5 Performance Monitoring for Electrical Cards

The following sections define PM parameters for the EC1-12, DS1/E1-56, DS1-14, DS1N-14, DS3-12, DS3-12E, DS3N-12, DS3N-12E, DS3i-N-12, DS3XM-6, DS3XM-12, and DS3/EC1-48 cards.

15.5.1 EC1-12 Card Performance Monitoring Parameters

Figure 15-2 shows signal types that support near-end and far-end PMs. Figure 15-3 shows where overhead bytes detected on the application specific integrated circuits (ASICs) produce PM parameters for the EC1-12 card.

Figure 15-2 Monitored Signal Types for the EC1-12 Card

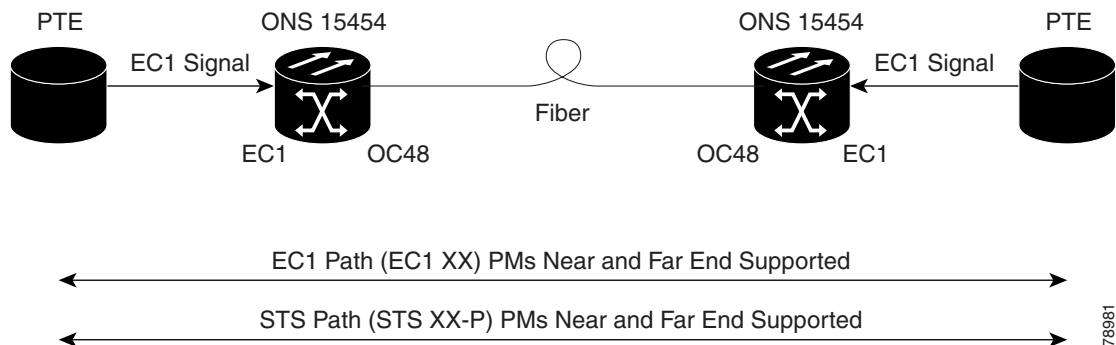

 **Note**

The XX in [Figure 15-2](#) represents all PMs listed in [Table 15-4](#) with the given prefix and/or suffix.

Figure 15-3 PM Read Points on the EC1-12 Card

ONS 15454

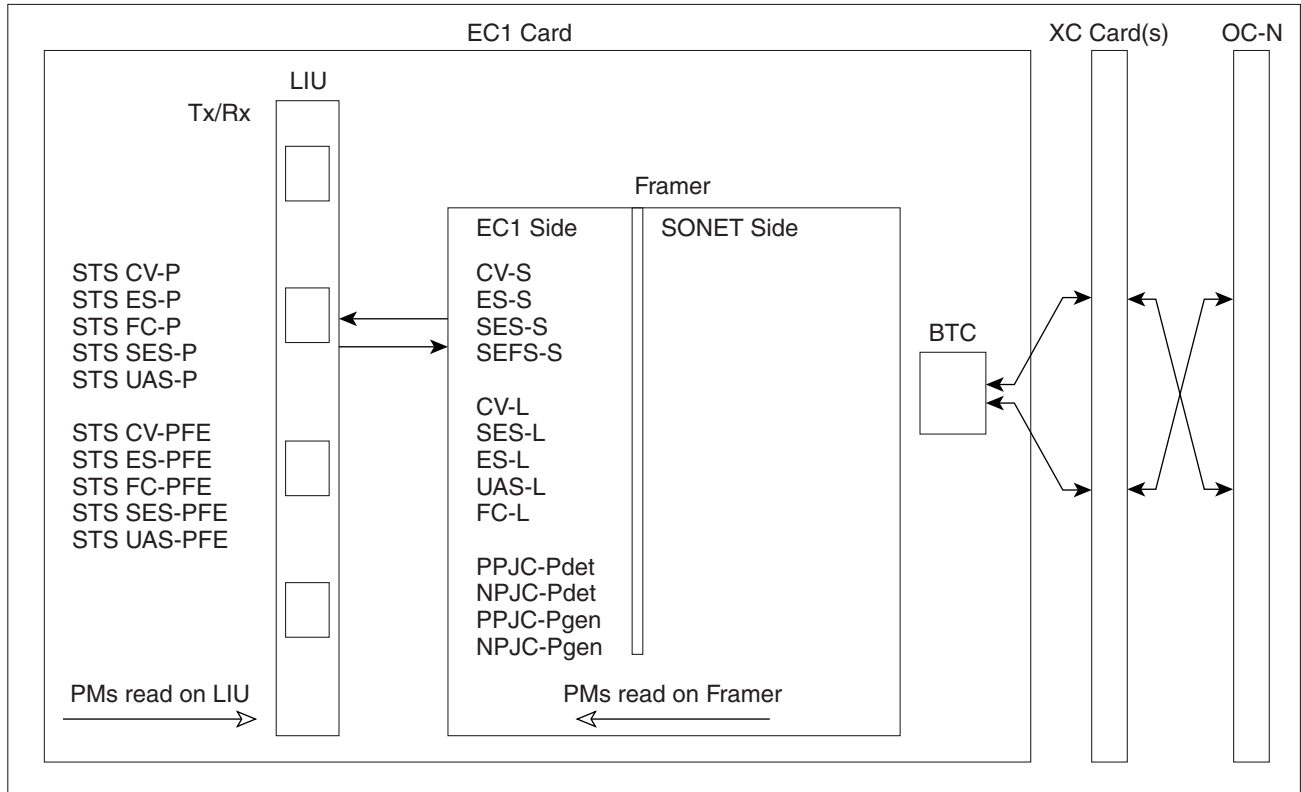

78982

[Table 15-4](#) lists the PM parameters for the EC1-12 cards.

Table 15-4 EC1-12 Card PMs

Section (NE)	Line (NE)	STS Path (NE)	Line (FE)	STS Path (FE)
CV-S	CV-L	CV-P	CV-LFE	CV-PFE
ES-S	ES-L	ES-P	ES-LFE	ES-PFE
SES-S	SES-L	SES-P	SES-LFE	SES-PFE
SEF-S	UAS-L	UAS-P	UAS-LFE	UAS-PFE
	FC-L	FC-P	FC-LFE	FC-PFE
		PPJC-PDET-P		
		NPJC-PDET-P		
		PPJC-PGEN-P		
		NPJC-PGEN-P		
		PJCS-PDET-P		
		PJCS-PGEN-P		
		PJC-DIFF-P		

15.5.2 DS1_E1_56 Card Performance Monitoring Parameters

Figure 15-4 shows signal types that support near-end and far-end PMs.

Figure 15-4 Monitored Signal Types for the DS1/E1-56 Card

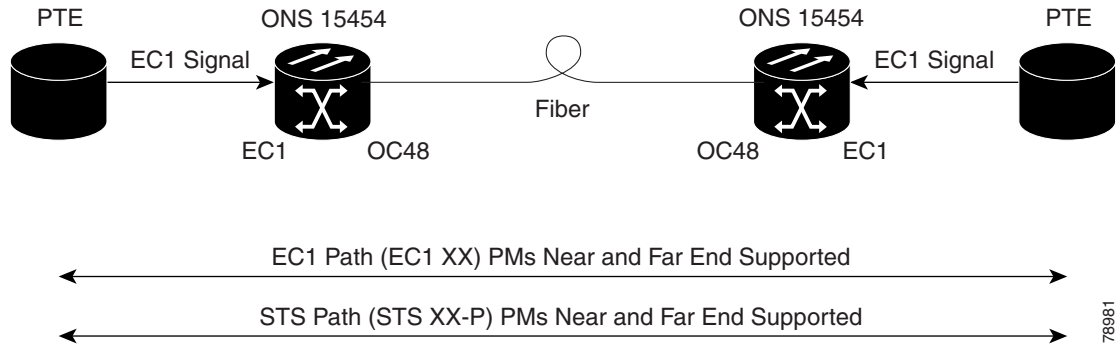

Figure 15-5 shows where overhead bytes detected on the ASICs produce PM parameters for the DS1/E1-56 card.

Figure 15-5 PM Read Points on the DS1/E1-56 Card

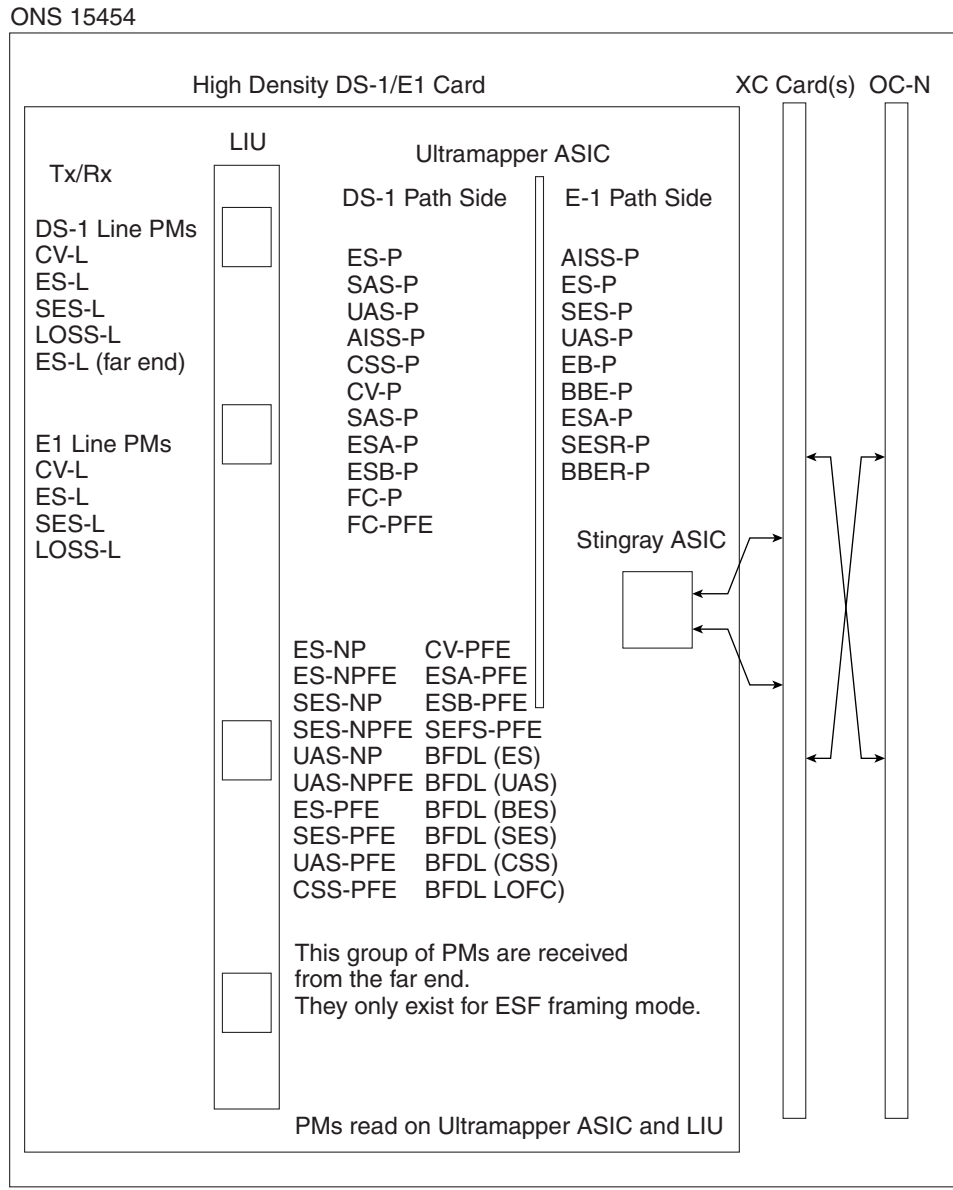

Table 15-5 lists the PM parameters for the DS1/E1-56 card.

Table 15-5 DS1/E1-56 Card PMs

Line (NE)	Line (FE)	Rx Path (NE)	Tx Path (NE)	STS Path (NE)	Rx Path (FE)	STS Path (FE)	Network Path	BFDL (FE)
CV-L	CV-L	AISS-P	AISS-P	CV-P	ES-PFE	CV-PFE	ES-NP	CSS
ES-L	ES-L	CV-P	CV-P	ES-P	ESA-PFE	ES-PFE	ES-NPFE	ES
SES-L		ES-P	ES-P	SES-P	ESB-PFE	SES-PFE	SES-NP	SES
LOSS-L		SES-P	SES-P	UAS-P	CV-PFE	UAS-PFE	SES-NPFE	BES
		SAS-P	UAS-P	FC-P	CSS-PFE	FC-PFE	UAS-NP	UAS
		UAS-P	BBER-P		SEFS-PFE		UAS-NPFE	LOFC
		CSS-P	SESR-P		SES-PFE			
		ESA-P	ESR-P		UAS-PFE			
		ESB-P						
		SEFS-P						

15.5.3 DS1-14 and DS1N-14 Card Performance Monitoring Parameters

Figure 15-6 shows the signal types that support near-end and far-end PMs.

Figure 15-6 Monitored Signal Types for the DS1-14 and DS1N-14 Cards

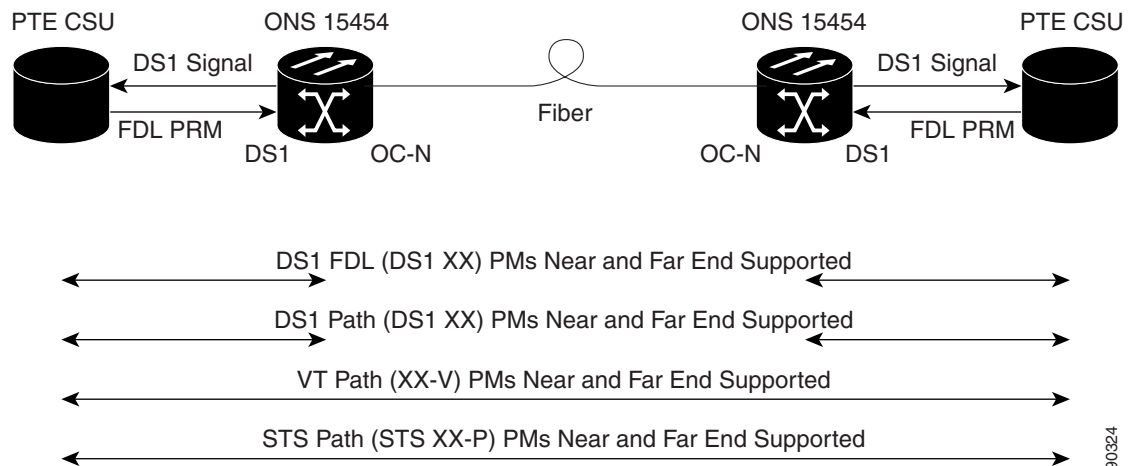

Note

The XX in Figure 15-6 represents all PMs listed in Table 15-6 with the given prefix and/or suffix.

Figure 15-7 shows where overhead bytes detected on the ASICs produce PM parameters for the DS1-14 and DS1N-14 cards.

Figure 15-7 PM Read Points on the DS1-14 and DS1N-14 Cards

ONS 15454

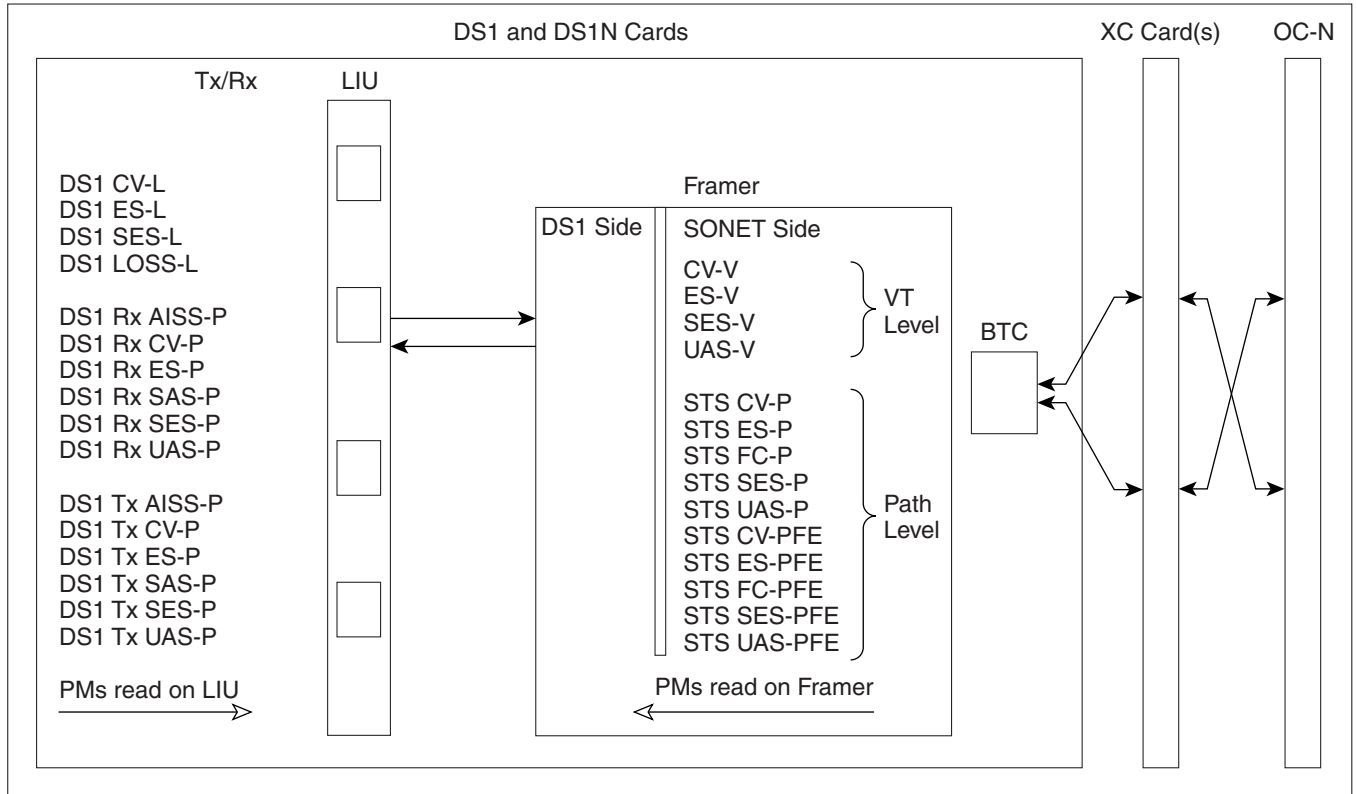

Table 15-6 describes the PM parameters for the DS1-14 and DS1N-14 cards.

Table 15-6 DS1-14 and DS1N-14 Card PMs

Line (NE)	Line (FE)	Rx Path (NE)	Tx Path (NE)	VT Path (NE)	STS Path (NE)	Rx Path (FE)	VT Path (FE)	STS Path (FE)
CV-L	CV-L	AISS-P	AISS-P	CV-V	CV-P	ES-PFE	CV-VFE	CV-PFE
ES-L	ES-L	CV-P	CV-P	ES-V	ES-P	ESA-PFE	ES-VFE	ES-PFE
SES-L		ES-P	ES-P	SES-V	SES-P	ES-B-PFE	SES-VFE	SES-PFE
LOSS-L		FC-P	FC-P	UAS-V	UAS-P	CV-PFE	UAS-VFE	UAS-PFE
		SAS-P	SAS-P	FC-V	FC-P	CSS-PFE	FC-VFE	FC-PFE
		SES-P	SES-P			SEFS-PFE		
		UAS-P	UAS-P			SES-PFE		
		CSS-P				UAS-PFE		
		ESA-P						
		ESB-P						
		SEFS-P						



Note Far-end DS1 performance monitoring values are valid only when the DS1 line is set to extended super frame (ESF).

15.5.3.1 DS-1 Facility Data Link Performance Monitoring

Facility Data Link (FDL) performance monitoring enables an ONS 15454 DS1N-14 card to calculate and report DS-1 error rate performance measured at both the near-end and far-end of the FDL. The far-end information is reported as received on the FDL in a performance report message (PRM) from an intelligent channel service unit (CSU).

To monitor DS-1 FDL PM values, the DS-1 must be set to use ESF format and the FDL must be connected to an intelligent CSU. For procedures for provisioning ESF on the DS1N-14 card, refer to the *Cisco ONS 15454 Procedure Guide*.

The monitored DS-1 FDL PM parameters are CV-PFE, ES-PFE, ESA-PFE, ESB-PFE, SES-PFE, SEFS-PFE, CSS-PFE, UAS-PFE, FC-PFE, and ES-LFE. See [Table 15-3 on page 15-5](#) for detailed information and definitions of specific FDL DS1 PM parameters.

15.5.4 DS3-12 and DS3N-12 Card Performance Monitoring Parameters

Figure 15-8 shows the signal types that support near-end and far-end PMs. [Figure 15-9](#) shows where overhead bytes detected on the ASICs produce PM parameters for the DS3-12 and DS3N-12 cards.

Figure 15-8 Monitored Signal Types for the DS3-12 and DS3N-12 Cards

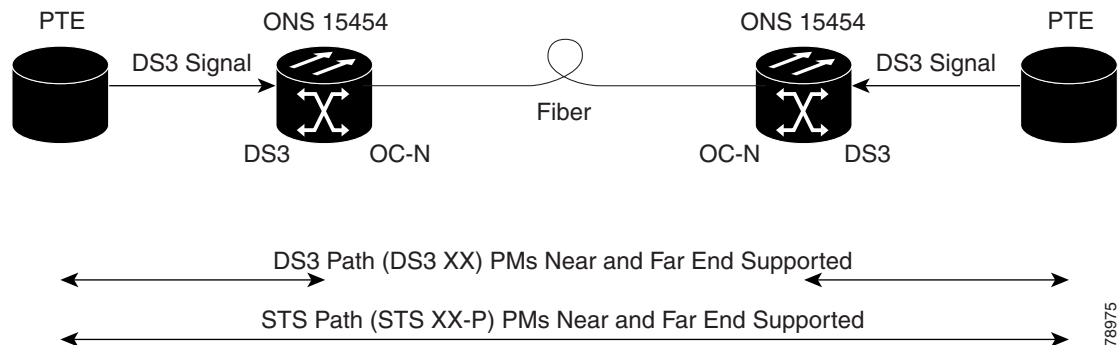

Note

The XX in Figure 15-8 represents all PMs listed in [Table 15-7](#) with the given prefix and/or suffix.

78975

Figure 15-9 PM Read Points on the DS3-12 and DS3N-12 Cards

ONS 15454

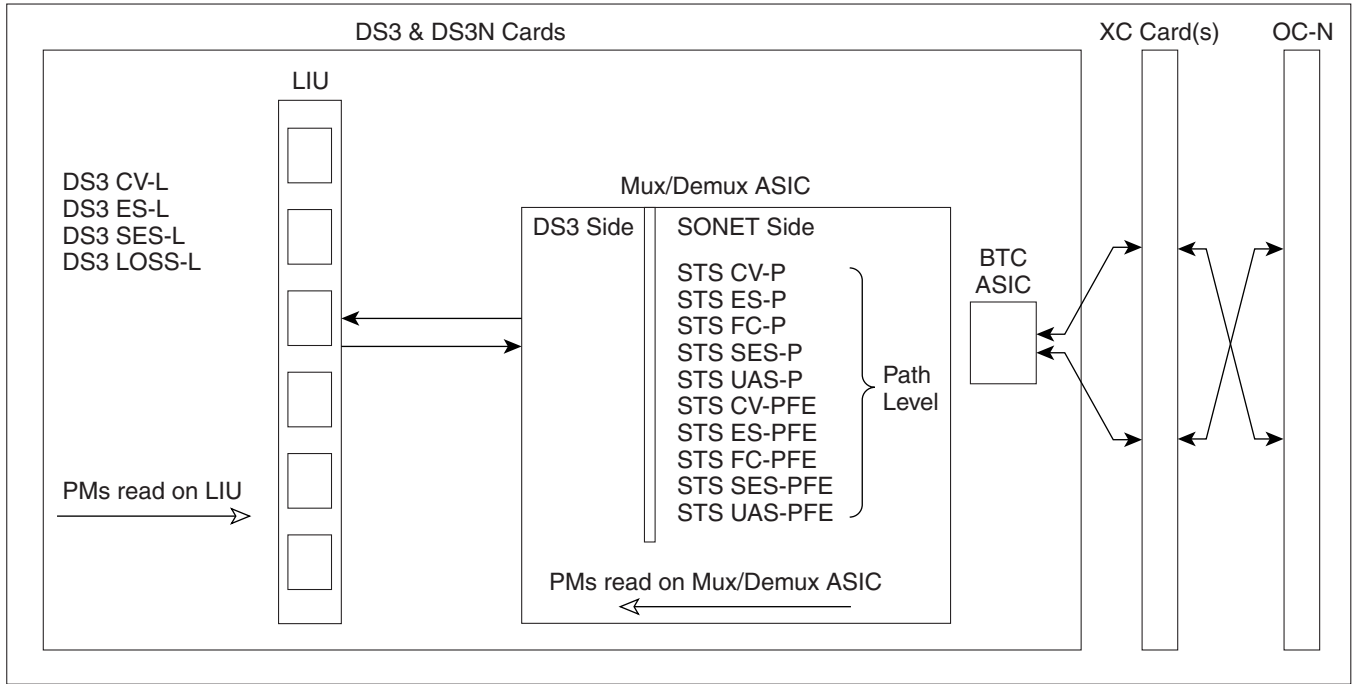

The PM parameters for the DS3-12 and DS3N-12 cards are described in [Table 15-7](#).

Table 15-7 DS3-12 and DS3N-12 Card PMs

Line (NE)	STS Path (NE)	STS Path (FE)
CV-L	CV-P	CV-PFE
ES-L	ES-P	ES-PFE
SES-L	SES-P	SES-PFE
LOSS-L	UAS-P	UAS-PFE
	FC-P	FC-PFE

15.5.5 DS3-12E and DS3N-12E Card Performance Monitoring Parameters

Figure 15-10 shows the signal types that support near-end and far-end PMs.

Figure 15-10 Monitored Signal Types for the DS3-12E and DS3N-12E Cards

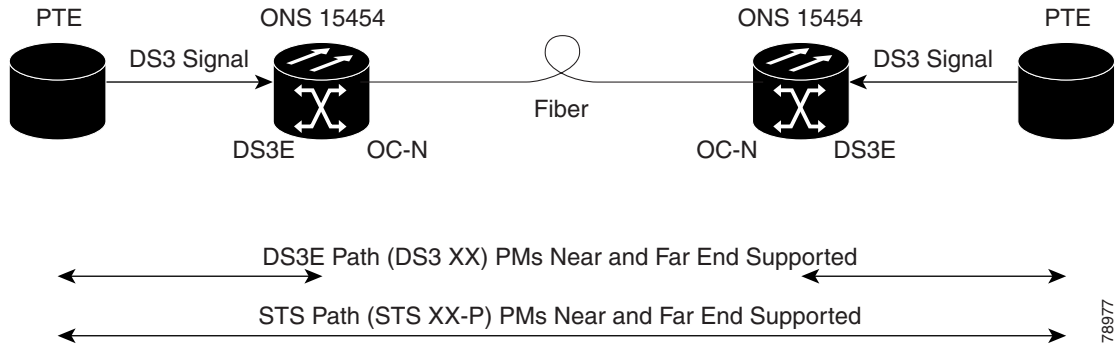

Note

The XX in Figure 15-10 represents all PMs listed in Table 15-8 with the given prefix and/or suffix.

Figure 15-11 shows where overhead bytes detected on the ASICs produce PM parameters for the DS3-12E and DS3N-12E cards.

Figure 15-11 PM Read Points on the DS3-12E and DS3N-12E Cards

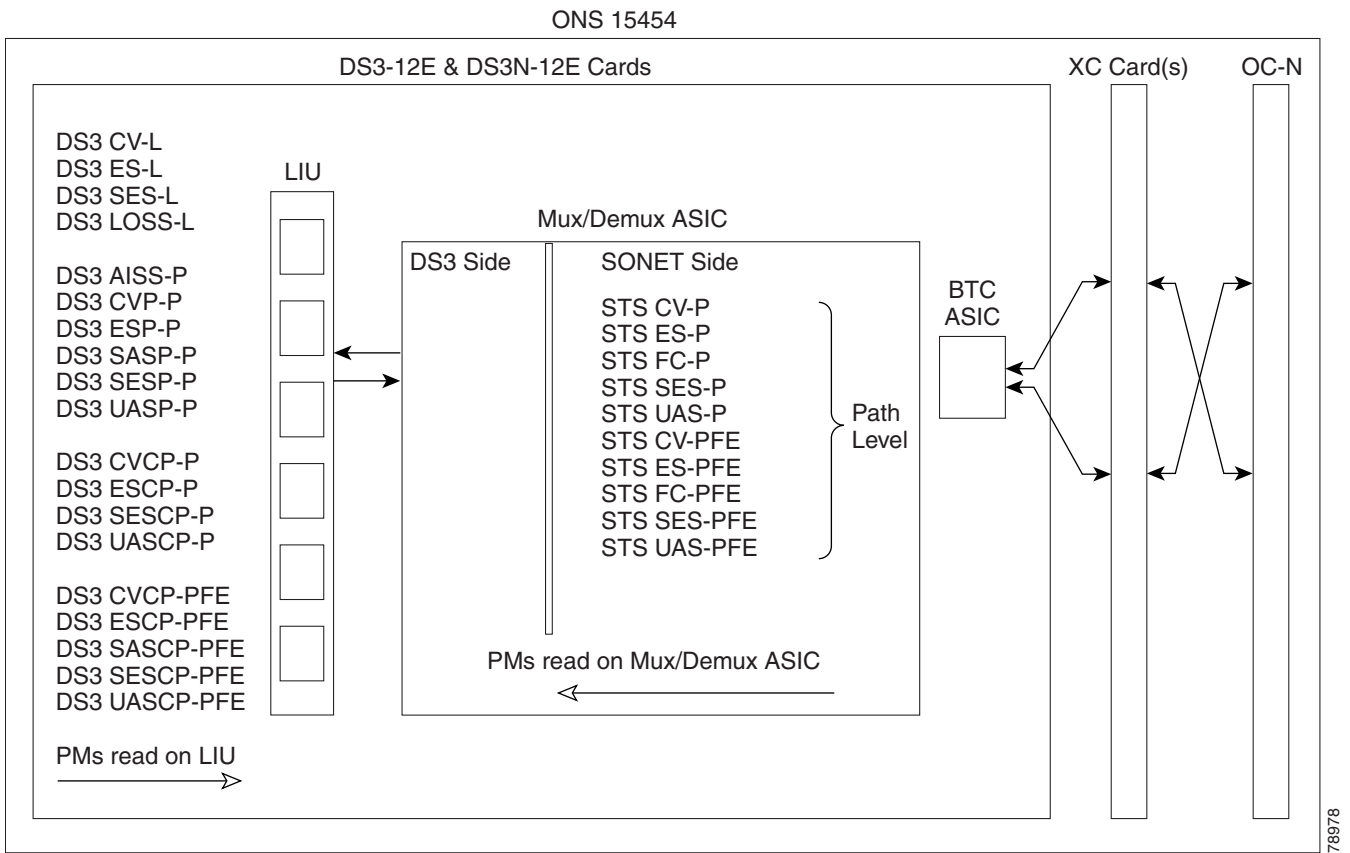

Table 15-8 describes the PM parameters for the DS3-12E and DS3N-12E cards.

Table 15-8 DS3-12E and DS3N-12E Card PMs

Line (NE)	Path (NE)	STS Path (NE)	Path (FE) ¹	STS Path (FE)
CV-L	AISS-P	CV-P	CVCP-PFE	CV-PFE
ES-L	CV-P	ES-P	ESCP-PFE	ES-PFE
SES-L	ES-P	SES-P	SASCP-P ³	SES-PFE
LOSS-L	SAS-P ²	UAS-P	SESCP-PFE	UAS-PFE
	SES-P	FC-P	UASCP-PFE	FC-PFE
	UAS-P			
	CVCP-P			
	ESCP-P			
	SASCP-P			
	SESCP-P			
	UASCP-P			

1. The C-bit PMs (PMs that contain the text "CP-P") are applicable only if the line format is C-bit.
2. DS3(N)-12E cards support SAS-P only on the receive (Rx) path.
3. The SASCP parameter is also displayed as "undefined" for near-end parameter though it is a far-end parameter.

15.5.6 DS3i-N-12 Card Performance Monitoring Parameters

Figure 15-12 shows the signal types that support near-end and far-end PMs.

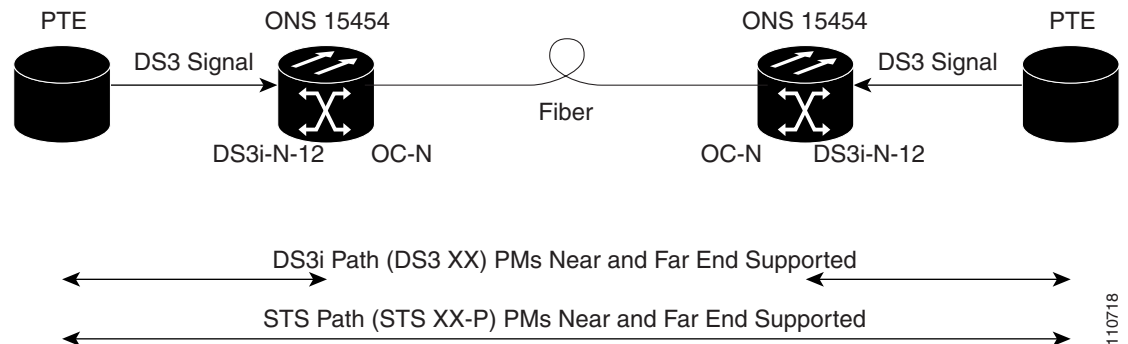
Figure 15-12 Monitored Signal Types for the DS3i-N-12 Cards**Note**

The XX in Figure 15-12 represents all PMs listed in Table 15-9 with the given prefix and/or suffix.

Figure 15-13 shows where overhead bytes detected on the ASICs produce PM parameters for the DS3i-N-12 cards.

Figure 15-13 PM Read Points on the DS3i-N-12 Cards

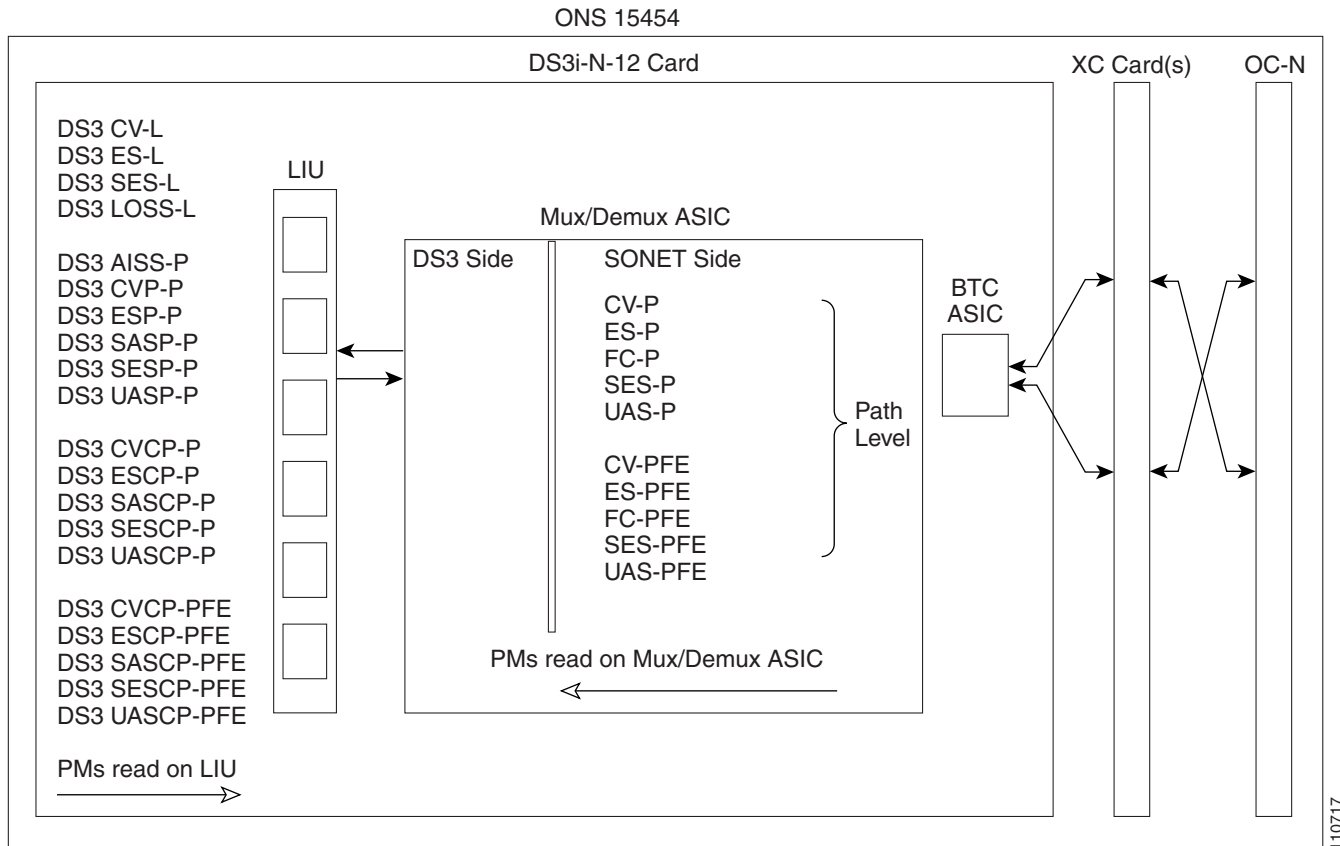

Table 15-9 describes the PM parameters for the DS3i-N-12 card.

Table 15-9 DS3i-N-12 Card PMs

Line (NE)	Path (NE)	STS Path (NE)	Path (FE) ¹	STS Path (FE)
CV-L	AISSP-P	CV-P	CVCP-PFE	CV-PFE
ES-L	CVP-P	ES-P	ESCP-PFE	ES-PFE
SES-L	ESP-P	SES-P	SASCP-PFE	SES-PFE
LOSS-L	SASP-P ²	UAS-P	SESCP-PFE	UAS-PFE
	SESP-P	FC-P	UASCP-PFE	FC-PFE
	UASP-P			
	CVCP-P			
	ESCP-P			
	SASCP-P ³			
	SESCP-P			
	UASCP-P			

1. The C-Bit PMs (PMs that contain the text "CP-P") are applicable only if the line format is C-Bit.
2. DS3i-N-12 cards support SAS-P only on the Rx path.
3. The SASCP parameter is also displayed as "undefined" for near-end parameter though it is a far-end parameter.

15.5.7 DS3XM-6 Card Performance Monitoring Parameters

Figure 15-14 shows the signal types that support near-end and far-end PMs.

Figure 15-14 Monitored Signal Types for the DS3XM-6 Card

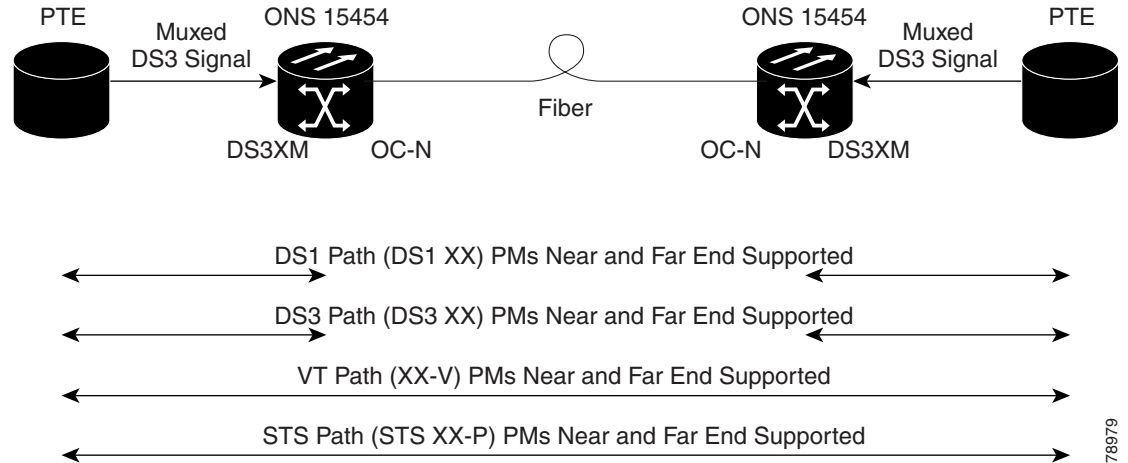

Note

The XX in Figure 15-14 represents all PMs listed in Table 15-10 with the given prefix and/or suffix.

Figure 15-15 shows where the overhead bytes detected on the ASICs produce PM parameters for the DS3XM-6 card.

Figure 15-15 PM Read Points on the DS3XM-6 Card

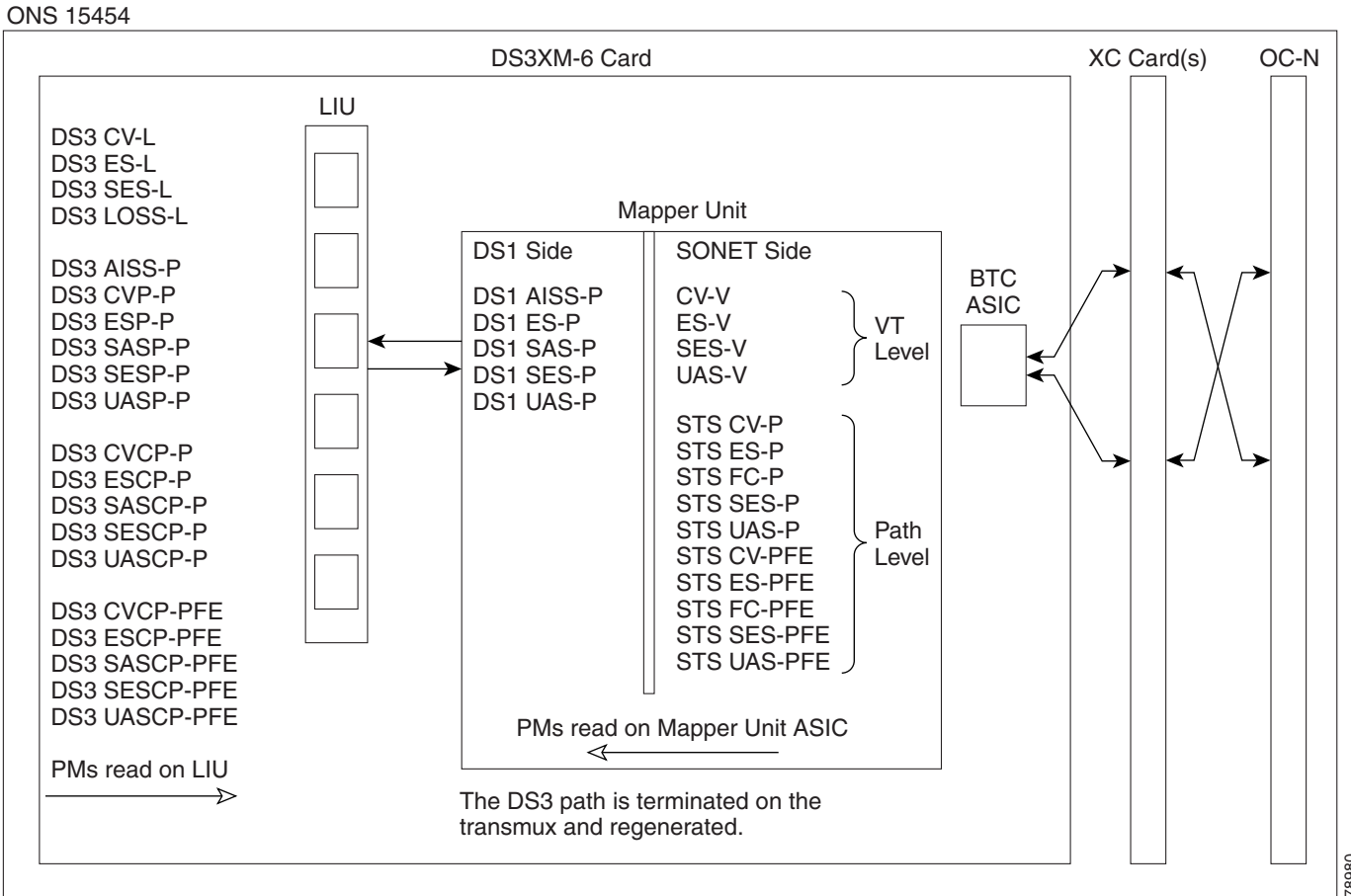

Table 15-10 lists the PM parameters for the DS3XM-6 cards.

Table 15-10 DS3XM-6 Card PMs

DS3 Line (NE)	DS3 Path (NE) ¹	DS1 Path (NE)	VT Path (NE)	STS Path (NE)	DS3 Path (FE) ¹	VT Path (FE)	STS Path (FE)	Network Path ²
CV-L	AISS-P	AISS-P	CV-V	CV-P	CVCP-PFE	CV-VFE	CV-PFE	ES-NP
ES-L	CVP-P	ES-P	ES-V	ES-P	ESCP-PFE	ES-VFE	ES-PFE	ES-NPFE
SES-L	ESP-P	SAS-P ³	SES-V	SES-P	SASCP-PFE	SES-VFE	SES-PFE	SES-NP
LOSS-L	SASP-P ³	SES-P	UAS-V	UAS-P	SESCP-PFE	UAS-VFE	UAS-PFE	SES-NPFE
	SESP-P	UAS-P		FC-P	UASCP-PFE		FC-PFE	UAS-NP
	UASP-P							UAS-NPFE
	ESCP-P							
	SASCP-P ⁴							
	SESCP-P							
	UASCP-P							
	CVCP-P							

1. The C-Bit PMs (PMs that contain the text “CP-P”) are applicable only if the line format is C-Bit.
2. Parameter received from far-end direction only.
3. DS3XM-6 cards support SAS-P only on the Rx path.
4. The SASCP parameter is also displayed as “undefined” for near-end parameter though it is a far-end parameter.

15.5.8 DS3XM-12 Card Performance Monitoring Parameters

Figure 15-16 shows the signal types that support near-end and far-end PMs.

Figure 15-16 Monitored Signal Types for the DS3XM-12 Card

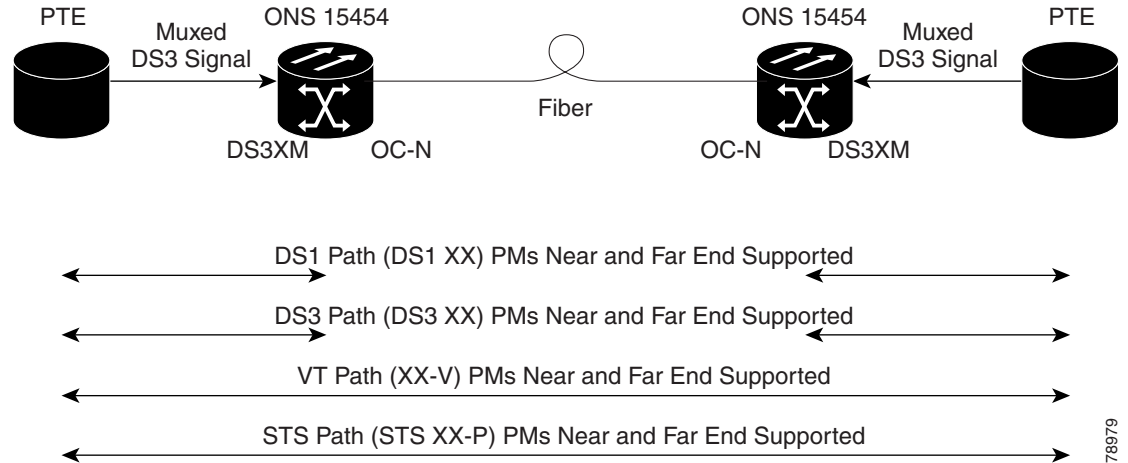

Note

The XX in Figure 15-16 represents all PMs listed in Table 15-11 with the given prefix and/or suffix.

Figure 15-17 shows where the overhead bytes detected on the ASICs produce PM parameters for the DS3XM-12 card.

78979

Figure 15-17 PM Read Points on the DS3XM-12 Card

ONS 15454

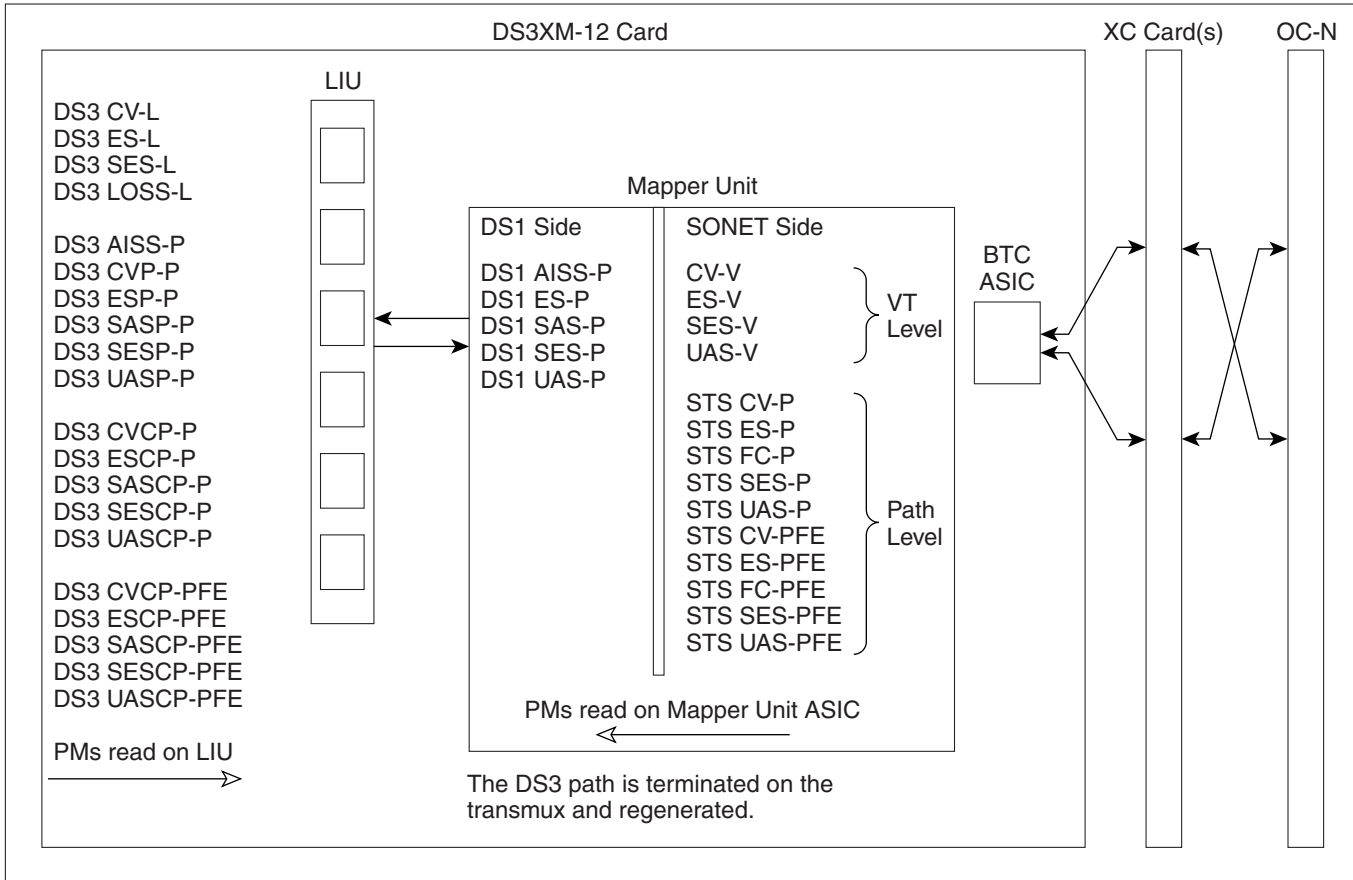

Table 15-11 lists the PM parameters for the DS3XM-12 cards.

Table 15-11 DS3XM-12 Card PMs

DS3 Line (NE)	DS3 Path (NE) ¹	DS1 Path (NE)	VT Path (NE)	STS Path (NE)	DS3 Path (FE) ¹	VT Path (FE)	STS Path (FE)	BFDL (FE)	Network Path ²
CV-L	AISS-P	AISS-P	CV-V	CV-P	CVCP-PFE	CV-VFE	CV-PFE	CSS	ES-NP
ES-L	CV-P	CV-P	ES-V	ES-P	ESCP-PFE	ES-VFE	ES-PFE	ES	ES-NPFE
SES-L	ES-P	ES-P	SES-V	SES-P	SASCP-PFE ⁴	SES-VFE	SES-PFE	SES	SES-NP
LOSS-L	SAS-P ³	FC-P	UAS-V	UAS-P	SESCO-PFE	UAS-VFE	UAS-PFE	BES	SES-NPFE
	SES-P	SAS-P ³		FC-P	UASCP-PFE		FC-PFE	UAS	UAS-NP
	UAS-P	SES-P						LOFC	UAS-NPFE
	ESCP-P	UAS-P							UAS-NP
	SESCO-P	CSS-P							UAS-NPFE
	UASCP-P	ESA-P							
	CVCP-P	ESB-P							
		SEFS-P							

1. The C-Bit PMs (PMs that contain the text "CP-P") are applicable only if the line format is C-Bit.
2. Parameter received from far-end direction only.
3. DS3XM-12 cards support SAS-P only on the Rx path.
4. The SASCP parameter is also displayed as "undefined" for near-end parameter though it is a far-end parameter.

15.5.9 DS3-EC1-48 Card Performance Monitoring Parameters

Figure 15-18 shows the signal types that support near-end and far-end PMs.

Figure 15-18 Monitored Signal Types for the DS3/EC1-48 Card

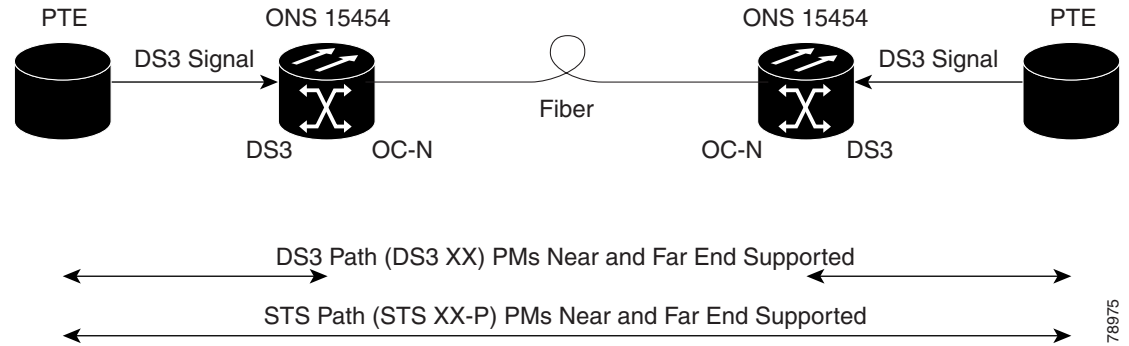

Note

The XX in Figure 15-18 represents all PMs listed in Table 15-12 with the given prefix and/or suffix.

Figure 15-19 shows where the overhead bytes detected on the ASICs produce PM parameters for the DS3-EC1-48 card.

Figure 15-19 PM Read Points on the DS3/EC1-48 Card

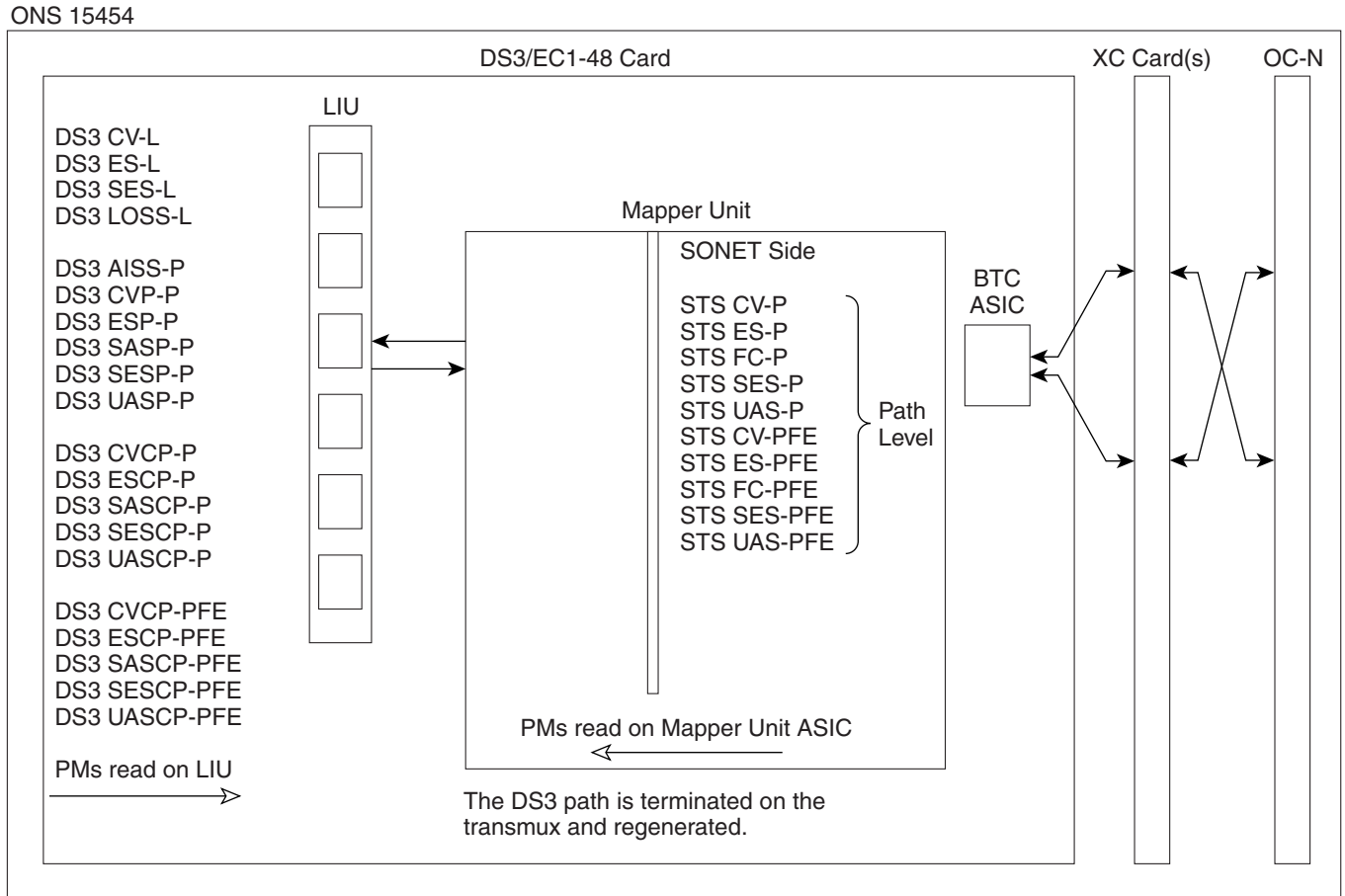

Table 15-12 lists the PM parameters for the DS3/EC1-48 cards.

Table 15-12 DS3/EC1-48 Card PMs

DS3 Line (NE)	DS3 Path (NE) ¹	STS Path (NE)	DS3 Path (FE) ¹	STS Path (FE)
CV-L	AISS-P	CV-P	CVCP-PFE	CV-PFE
ES-L	CVP-P	ES-P	ESCP-PFE	ES-PFE
SES-L	ESP-P	SES-P	SASCP-PFE	SES-PFE
LOSS-L	SASP-P ²	UAS-P	SESCP-PFE	UAS-PFE
	SESP-P	FC-P	UASCP-PFE	FC-PFE
	UASP-P			
	ESCP-P			
	SASCP-P ³			
	SESCP-P			
	UASCP-P			
	CVCP-P			

1. The C-Bit PMs (PMs that contain the text "CP-P") are applicable only if the line format is C-Bit.
2. DS3/EC1-48 cards support SAS-P only on the Rx path.
3. The SASCP parameter is also displayed as "undefined" for near-end parameter though it is a far-end parameter.

15.6 Performance Monitoring for Ethernet Cards

The following sections define PM parameters and definitions for the ONS 15454 E-Series, G-Series, ML-Series, and CE-Series Ethernet cards.

15.6.1 E-Series Ethernet Card Performance Monitoring Parameters

CTC provides Ethernet performance information, including line-level parameters, port bandwidth consumption, and historical Ethernet statistics. The E-Series Ethernet performance information is divided into the Statistics, Utilization, and History tabbed windows within the card view Performance tab window.

15.6.1.1 E-Series Ethernet Statistics Window

The Ethernet Statistics window lists Ethernet parameters at the line level. The Statistics window provides buttons to change the statistical values shown. The Baseline button resets the displayed statistics values to zero. The Refresh button manually refreshes statistics. Auto-Refresh sets a time interval at which automatic refresh occurs.

[Table 15-13](#) defines the E-Series Ethernet card statistics parameters.

Table 15-13 E-Series Ethernet Statistics Parameters

Parameter	Definition
Link Status	Indicates whether link integrity is present; up means present, and down means not present.
ifInOctets	Number of bytes received since the last counter reset.
ifInUcastPkts	Number of unicast packets received since the last counter reset.
ifInErrors	The number of inbound packets (or transmission units) that contained errors preventing them from being deliverable to a higher-layer protocol.
ifOutOctets	Number of bytes transmitted since the last counter reset.
ifOutUcastPkts	Number of unicast packets transmitted.
dot3StatsAlignmentErrors	A count of frames received on a particular interface that are not an integral number of octets in length and do not pass the FCS check.
dot3StatsFCSErrors	A count of frames received on a particular interface that are an integral number of octets in length but do not pass the FCS check.
dot3StatsFrameTooLong	A count of frames received on a particular interface that exceed the maximum permitted frame size.
etherStatsUndersizePkts	The total number of packets received that were less than 64 octets long (excluding framing bits, but including FCS octets) and were otherwise well formed.

Table 15-13 E-Series Ethernet Statistics Parameters (continued)

Parameter	Definition
etherStatsFragments	The total number of packets received that were less than 64 octets in length (excluding framing bits but including FCS octets) and had either a bad FCS with an integral number of octets (FCS Error) or a bad FCS with a nonintegral number of octets (Alignment Error). Note It is entirely normal for etherStatsFragments to increment. This is because it counts both runts (which are normal occurrences due to collisions) and noise hits.
etherStatsPkts64Octets	The total number of packets (including bad packets) received that were 64 octets in length (excluding framing bits but including FCS octets).
etherStatsPkts65to127 Octets	The total number of packets (including bad packets) received that were between 65 and 127 octets in length inclusive (excluding framing bits but including FCS octets).
etherStatsPkts128to255 Octets	The total number of packets (including bad packets) received that were between 128 and 255 octets in length inclusive (excluding framing bits but including FCS octets).
etherStatsPkts256to511 Octets	The total number of packets (including bad packets) received that were between 256 and 511 octets in length inclusive (excluding framing bits but including FCS octets).
etherStatsPkts512to1023 Octets	The total number of packets (including bad packets) received that were between 512 and 1023 octets in length inclusive (excluding framing bits but including FCS octets).
etherStatsPkts1024to1518 Octets	The total number of packets (including bad packets) received that were between 1024 and 1518 octets in length inclusive (excluding framing bits but including FCS octets).
etherStatsOversizePkts	The total number of packets received that were longer than 1518 octets (excluding framing bits, but including FCS octets) and were otherwise well formed. Note that for tagged interfaces, this number becomes 1522 bytes.
etherStatsJabbers	The total number of packets received that were longer than 1518 octets (excluding framing bits, but including FCS octets), and had either a bad FCS with an integral number of octets (FCS Error) or a bad FCS with a nonintegral number of octets (Alignment Error).
etherStatsOctets	The total number of octets of data (including those in bad packets) received on the network (excluding framing bits but including FCS octets)
etherStatsCRCAlign Errors	The total number of packets received that had a length (excluding framing bits, but including FCS octets) of between 64 and 1518 octets, inclusive, but had either a bad FCS with an integral number of octets (FCS Error) or a bad FCS with a nonintegral number of octets (Alignment Error).

15.6.1.2 E-Series Ethernet Utilization Window

The Utilization window shows the percentage of transmit (Tx) and receive (Rx) line bandwidth used by the Ethernet ports during consecutive time segments. The Mode field displays the real-time mode status, such as 100 Full, which is the mode setting configured on the E-Series port. However, if the E-Series port is set to autonegotiate the mode (Auto), this field shows the result of the link negotiation between the E-Series and the peer Ethernet device attached directly to the E-Series port.

The Utilization window provides an Interval drop-down list that enables you to set time intervals of 1 minute, 15 minutes, 1 hour, and 1 day. Line utilization is calculated with the following formulas:

$$Rx = (inOctets + inPkts * 20) * 8 / 100\% \text{ interval} * \text{maxBaseRate}$$

$$Tx = (outOctets + outPkts * 20) * 8 / 100\% \text{ interval} * \text{maxBaseRate}$$

The interval is defined in seconds. The maxBaseRate is defined by raw bits per second in one direction for the Ethernet port (that is, 1 Gbps). The maxBaseRate for E-Series Ethernet cards is shown in [Table 15-14](#).

Table 15-14 maxBaseRate for STS Circuits

STS	maxBaseRate
STS-1	51840000
STS-3c	155000000
STS-6c	311000000
STS-12c	622000000



Note

Line utilization numbers express the average of ingress and egress traffic as a percentage of capacity.



Note

The E-Series Ethernet card is a Layer 2 device or switch and supports Trunk Utilization statistics. The Trunk Utilization statistics are similar to the Line Utilization statistics, but shows the percentage of circuit bandwidth used rather than the percentage of line bandwidth used. The Trunk Utilization statistics are accessed through the card view Maintenance tab.

15.6.1.3 E-Series Ethernet History Window

The Ethernet History window lists past Ethernet statistics for the previous time intervals. Depending on the selected time interval, the History window displays the statistics for each port for the number of previous time intervals as shown in [Table 15-15](#). The parameters are defined in [Table 15-13 on page 15-29](#).

Table 15-15 Ethernet History Statistics per Time Interval

Time Interval	Number of Previous Intervals Displayed
1 minute	60
15 minutes	32
1 hour	24
1 day (24 hours)	7

15.6.2 G-Series Ethernet Card Performance Monitoring Parameters

CTC provides Ethernet performance information, including line-level parameters, port bandwidth consumption, and historical Ethernet statistics. The G-Series Ethernet performance information is divided into the Statistics, Utilization, and History tabbed windows within the card view Performance tab window.

15.6.2.1 G-Series Ethernet Statistics Window

The Ethernet Statistics window lists Ethernet parameters at the line level. The Statistics window provides buttons to change the statistical values shown. The Baseline button resets the displayed statistics values to zero. The Refresh button manually refreshes statistics. Auto-Refresh sets a time interval at which automatic refresh occurs. The G-Series Statistics window also has a Clear button. The Clear button sets the values on the card to zero, but does not reset the G-Series card.

Table 15-16 defines the G-Series Ethernet card statistics parameters.

Table 15-16 G-Series Ethernet Statistics Parameters

Parameter	Definition
Time Last Cleared	A time stamp indicating the last time statistics were reset.
Link Status	Indicates whether the Ethernet link is receiving a valid Ethernet signal (carrier) from the attached Ethernet device; up means present, and down means not present.
Rx Packets	Number of packets received since the last counter reset.
Rx Bytes	Number of bytes received since the last counter reset.
Tx Packets	Number of packets transmitted since the last counter reset.
Tx Bytes	Number of bytes transmitted since the last counter reset.
Rx Total Errors	Total number of receive errors.
Rx FCS	Number of packets with a FCS error. FCS errors indicate frame corruption during transmission.
Rx Alignment	Number of packets with received incomplete frames.
Rx Runts	Measures undersized packets with bad CRC errors.
Rx Shorts	Measures undersized packets with good CRC errors.
Rx Jabbers	The total number of frames received that exceed the 1548-byte maximum and contain CRC errors.
Rx Giants	Number of packets received that are greater than 1530 bytes in length.
Rx Pause Frames	Number of received Ethernet IEEE 802.3z pause frames.
Tx Pause Frames	Number of transmitted IEEE 802.3z pause frames.
Rx Pkts Dropped Internal Congestion	Number of received packets dropped due to overflow in G-Series frame buffer.
Tx Pkts Dropped Internal Congestion	Number of transmit queue drops due to drops in the G-Series frame buffer.
HDLC Errors	High-level data link control (HDLC) errors received from SONET/SDH (see Note).

Table 15-16 G-Series Ethernet Statistics Parameters (continued)

Parameter	Definition
Rx Unicast Packets	Number of unicast packets received since the last counter reset.
Tx Unicast Packets	Number of unicast packets transmitted.
Rx Multicast Packets	Number of multicast packets received since the last counter reset.
Tx Multicast Packets	Number of multicast packets transmitted.
Rx Broadcast Packets	Number of broadcast packets received since the last counter reset.
Tx Broadcast Packets	Number or broadcast packets transmitted.

**Note**

Do not use the HDLC errors counter to count the number of frames dropped because of HDLC errors, because each frame can fragment into several smaller frames during HDLC error conditions and spurious HDLC frames can be generated. If HDLC error counters are incrementing when no SONET path problems should be present, it might indicate a problem with the quality of the SONET path. For example, a SONET protection switch generates a set of HDLC errors. However, the actual values of these counters are less significant than the fact that they are changing.

15.6.2.2 G-Series Ethernet Utilization Window

The Utilization window shows the percentage of Tx and Rx line bandwidth used by the Ethernet ports during consecutive time segments. The Mode field displays the real-time mode status, such as 100 Full, which is the mode setting configured on the G-Series port. However, if the G-Series port is set to autonegotiate the mode (Auto), this field shows the result of the link negotiation between the G-Series and the peer Ethernet device attached directly to the G-Series port.

The Utilization window provides an Interval drop-down list that enables you to set time intervals of 1 minute, 15 minutes, 1 hour, and 1 day. Line utilization is calculated with the following formulas:

$$\text{Rx} = (\text{inOctets} + \text{inPkts} * 20) * 8 / 100\% \text{ interval} * \text{maxBaseRate}$$

$$\text{Tx} = (\text{outOctets} + \text{outPkts} * 20) * 8 / 100\% \text{ interval} * \text{maxBaseRate}$$

The interval is defined in seconds. The maxBaseRate is defined by raw bits per second in one direction for the Ethernet port (that is, 1 Gbps). The maxBaseRate for G-Series Ethernet cards is shown in [Table 15-14](#).

**Note**

Line utilization numbers express the average of ingress and egress traffic as a percentage of capacity.

**Note**

Unlike the E-Series, the G-Series card does not have a display of Trunk Utilization statistics, because the G-Series card is not a Layer 2 device or switch.

15.6.2.3 G-Series Ethernet History Window

The Ethernet History window lists past Ethernet statistics for the previous time intervals. Depending on the selected time interval, the History window displays the statistics for each port for the number of previous time intervals as shown in [Table 15-15 on page 15-31](#). The listed parameters are defined in [Table 15-16 on page 15-32](#).

15.6.3 ML-Series Ethernet Card Performance Monitoring Parameters

CTC provides Ethernet performance information for line-level parameters and historical Ethernet statistics. The ML-Series Ethernet performance information is divided into the Ether Ports and Packet-over-SONET (POS) Ports tabbed windows within the card view Performance tab window.

15.6.3.1 ML-Series Ether Ports Window

[Table 15-17](#) defines the ML-Series Ethernet card Ether Ports PM parameters.

Table 15-17 ML-Series Ether Ports PM Parameters

Parameter	Definition
ifInOctets	Number of bytes received since the last counter reset.
rxTotalPackets	Number of packets received.
ifInUcastPkts	Number of unicast packets received since the last counter reset.
ifInMulticast Pkts	Number of multicast packets received since the last counter reset.
ifInBroadcast Pkts	Number of broadcast packets received since the last counter reset.
ifInDiscards	The number of inbound packets that were chosen to be discarded even though no errors had been detected to prevent their being deliverable to a higher-layer protocol. One possible reason for discarding such a packet could be to free up buffer space.
ifOutOctets	Number of bytes transmitted since the last counter reset.
txTotalPkts	Number of transmitted packets.
ifOutUcast Pkts	Number of unicast packets transmitted.
ifOutMulticast Pkts	Number of multicast packets transmitted.
ifOutBroadcast Pkts	Number or broadcast packets transmitted.
dot3StatsAlignmentErrors	A count of frames received on a particular interface that are not an integral number of octets in length and do not pass the FCS check.
dot3StatsFCSErrors	A count of frames received on a particular interface that are an integral number of octets in length but do not pass the FCS check.
etherStatsUndersizePkts	The total number of packets received that were less than 64 octets long (excluding framing bits, but including FCS octets) and were otherwise well formed.
etherStatsOversizePkts	The total number of packets received that were longer than 1518 octets (excluding framing bits, but including FCS octets) and were otherwise well formed. Note that for tagged interfaces, this number becomes 1522 bytes.

Table 15-17 ML-Series Ether Ports PM Parameters (continued)

Parameter	Definition
etherStatsJabbers	The total number of packets received that were longer than 1518 octets (excluding framing bits, but including FCS octets), and had either a bad FCS with an integral number of octets (FCS Error) or a bad FCS with a nonintegral number of octets (Alignment Error).
etherStatsCollissions	Number of transmit packets that are collisions; the port and the attached device transmitting at the same time caused collisions.
etherStatsDropEvents	Number of received frames dropped at the port level.
rx PauseFrames	Number of received Ethernet 802.3z pause frames.
mediaIndStatsOversize Dropped	Number of received oversized packages that are dropped.
mediaIndStatsTxFrames TooLong	Number of received frames that are too long. The maximum is the programmed max frame size (for virtual SAN [VSAN] support); if the maximum frame size is set to default, then the maximum is a 2112 byte payload plus the 36 byte header, which is a total of 2148 bytes.

15.6.3.2 ML-Series POS Ports Window

In the ML-Series POS Ports window, the parameters displayed depend on the framing mode employed by the ML-Series card. The two framing modes for the POS port on the ML-Series card are HDLC and frame-mapped generic framing procedure (GFP-F). For more information on provisioning a framing mode, refer to *Cisco ONS 15454 Procedure Guide*.

[Table 15-18](#) defines the ML-Series Ethernet card POS Ports HDLC parameters. [Table 15-19](#) defines the ML-Series Ethernet card POS Ports GFP-F parameters.

Table 15-18 ML-Series POS Ports Parameters for HDLC Mode

Parameter	Definition
ifInOctets	Number of bytes received since the last counter reset.
rxTotalPkts	Number of packets received.
ifOutOctets	Number of bytes transmitted since the last counter reset.
tx TotalPkts	Number of transmitted packets.
etherStatsDropEvents	Number of received frames dropped at the port level.
rxPktsDropped Internal Congestion	Number of received packets dropped due to overflow in frame buffer.
mediaIndStatsRxFrames Truncated	Number of received frames with a length of 36 bytes or less.
mediaIndStatsRxFrames TooLong	Number of received frames that are too long. The maximum is the programmed maximum frame size (for VSAN support); if the maximum frame size is set to default, then the maximum is the 2112 byte payload plus the 36 byte header, which is a total of 2148 bytes.
mediaIndStatsRxFrames BadCRC	Number of received frames with CRC errors.

Table 15-18 ML-Series POS Ports Parameters for HDLC Mode (continued)

Parameter	Definition
mediaIndStatsRxShortPkts	Number of received packets that are too small.
hdlcInOctets	Number of bytes received (from the SONET/SDH path) prior to the bytes undergoing HLDC decapsulation by the policy engine.
hdlcRxAborts	Number of received packets aborted on input.
hdlcOutOctets	Number of bytes transmitted (to the SONET/SDH path) after the bytes undergoing HLDC encapsulation by the policy engine.

Table 15-19 ML-Series POS Ports Parameters for GFP-F Mode

Parameter	Meaning
etherStatsDropEvents	Number of received frames dropped at the port level.
rxPktsDroppedInternalCongestion	Number of received packets dropped due to overflow in the frame buffer.
gfpStatsRxFrame	Number of received GFP frames.
gfpStatsTxFrame	Number of transmitted GFP frames.
gfpStatsRxOctets	Number of GFP bytes received.
gfpStatsTxOctets	Number of GFP bytes transmitted.
gfpStatsRxSBitErrors	Sum of all the single bit errors. In the GFP CORE HDR at the GFP-T receiver, these are correctable.
gfpStatsRxMBitErrors	Sum of all the multiple bit errors. In the GFP CORE HDR at the GFP-T receiver, these are uncorrectable.
gfpStatsRxTypeInvalid	Number of receive packets dropped due to Client Data Frame UPI errors.
gfpStatsRxCRCErrors	Number of packets received with a payload FCS error.
gfpStatsLFDRaised	Count of core HEC CRC multiple bit errors. Note This count is only of eHec multiple bit errors when in frame. This can be looked at as a count of when the state machine goes out of frame.
gfpStatsCSFRaised	Number of GFP Client signal fail frames detected at the GFP-T receiver.
mediaIndStatsRxFramesTruncated	Number of received frames that are too long. The maximum is the programmed maximum frame size (for VSAN support); if the maximum frame size is set to default, then the maximum is the 2112 byte payload plus the 36 byte header, which is a total of 2148 bytes.
mediaIndStatsRxFramesTooLong	Number of received frames with CRC error.s
mediaIndStatsRxShortPkts	Number of received packets that are too small.

15.6.4 CE-Series Ethernet Card Performance Monitoring Parameters

CTC provides Ethernet performance information, including line-level parameters, port bandwidth consumption, and historical Ethernet statistics. The CE-Series card Ethernet performance information is divided into Ether Ports and POS Ports tabbed windows within the card view Performance tab window.

15.6.4.1 CE-Series Card Ether Port Statistics Window

The Ethernet Ether Ports Statistics window lists Ethernet parameters at the line level. The Statistics window provides buttons to change the statistical values shown. The Baseline button resets the displayed statistics values to zero. The Refresh button manually refreshes statistics. Auto-Refresh sets a time interval at which automatic refresh occurs. The CE-Series Statistics window also has a Clear button. The Clear button sets the values on the card to zero, but does not reset the CE-Series card.

During each automatic cycle, whether auto-refreshed or manually refreshed (using the Refresh button), statistics are added cumulatively and are not immediately adjusted to equal total received packets until testing ends. To see the final PM count totals, allow a few moments for the PM window statistics to finish testing and update fully. PM counts are also listed in the CE-Series card Performance > History window.

Table 15-20 defines the CE-Series card Ethernet port parameters.

Table 15-20 CE-Series Ether Port PM Parameters

Parameter	Definition
Time Last Cleared	A time stamp indicating the last time statistics were reset.
Link Status	Indicates whether the Ethernet link is receiving a valid Ethernet signal (carrier) from the attached Ethernet device; up means present, and down means not present.
ifInOctets	Number of bytes received since the last counter reset.
rxTotalPkts	Number of received packets.
ifInUcastPkts	Number of unicast packets received since the last counter reset.
ifInMulticastPkts	Number of multicast packets received since the last counter reset.
ifInBroadcastPkts	Number of broadcast packets received since the last counter reset.
ifInDiscards	The number of inbound packets that were chosen to be discarded even though no errors had been detected to prevent their being deliverable to a higher-layer protocol. One possible reason for discarding such a packet could be to free buffer space.
ifInErrors	The number of inbound packets (or transmission units) that contained errors preventing them from being deliverable to a higher-layer protocol.
ifOutOctets	Number of bytes transmitted since the last counter reset.
txTotalPkts	Number of transmitted packets.
ifOutDiscards ¹	Number of outbound packets which were chosen to be discarded even though no errors had been detected to prevent their transmission. A possible reason for discarding such packets could be to free up buffer space.
ifOutErrors ¹	Number of outbound packets or transmission units that could not be transmitted because of errors.
ifOutUcastPkts ²	Number of unicast packets transmitted.

Table 15-20 CE-Series Ether Port PM Parameters (continued)

Parameter	Definition
ifOutMulticastPkts ²	Number of multicast packets transmitted.
ifOutBroadcastPkts ²	Number of broadcast packets transmitted.
dot3StatsAlignmentErrors ²	A count of frames received on a particular interface that are not an integral number of octets in length and do not pass the FCS check.
dot3StatsFCSErrors	A count of frames received on a particular interface that are an integral number of octets in length but do not pass the FCS check.
dot3StatsSingleCollisionFrames ²	A count of successfully transmitted frames on a particular interface for which transmission is inhibited by exactly on collision.
dot3StatsFrameTooLong	A count of frames received on a particular interface that exceed the maximum permitted frame size.
etherStatsUndersizePkts	The total number of packets received that were less than 64 octets long (excluding framing bits, but including FCS octets) and were otherwise well formed.
etherStatsFragments	The total number of packets received that were less than 64 octets in length (excluding framing bits but including FCS octets) and had either a bad FCS with an integral number of octets (FCS Error) or a bad FCS with a nonintegral number of octets (Alignment Error). Note It is entirely normal for etherStatsFragments to increment. This is because it counts both runts (which are normal occurrences due to collisions) and noise hits.
etherStatsPkts64Octets	The total number of packets (including bad packets) received that were 64 octets in length (excluding framing bits but including FCS octets).
etherStatsPkts65to127Octets	The total number of packets (including bad packets) received that were between 65 and 127 octets in length inclusive (excluding framing bits but including FCS octets).
etherStatsPkts128to255Octets	The total number of packets (including bad packets) received that were between 128 and 255 octets in length inclusive (excluding framing bits but including FCS octets).
etherStatsPkts256to511Octets	The total number of packets (including bad packets) received that were between 256 and 511 octets in length inclusive (excluding framing bits but including FCS octets).
etherStatsPkts512to1023Octets	The total number of packets (including bad packets) received that were between 512 and 1023 octets in length inclusive (excluding framing bits but including FCS octets).
etherStatsPkts1024to1518Octets	The total number of packets (including bad packets) received that were between 1024 and 1518 octets in length inclusive (excluding framing bits but including FCS octets).
etherStatsBroadcastPkts	The total number of good packets received that were directed to the broadcast address. Note that this does not include multicast packets.
etherStatsMulticastPkts	The total number of good packets received that were directed to a multicast address. Note that this number does not include packets directed to the broadcast address.

Table 15-20 CE-Series Ether Port PM Parameters (continued)

Parameter	Definition
etherStatsOversizePkts	The total number of packets received that were longer than 1518 octets (excluding framing bits, but including FCS octets) and were otherwise well formed. Note that for tagged interfaces, this number becomes 1522 bytes.
etherStatsJabbers	The total number of packets received that were longer than 1518 octets (excluding framing bits, but including FCS octets), and had either a bad FCS with an integral number of octets (FCS Error) or a bad FCS with a nonintegral number of octets (Alignment Error).
etherStatsOctets	The total number of octets of data (including those in bad packets) received on the network (excluding framing bits but including FCS octets)
etherStatsCollisions ²	Number of transmit packets that are collisions; the port and the attached device transmitting at the same time caused collisions.
etherStatsCRCAAlign Errors ²	The total number of packets received that had a length (excluding framing bits, but including FCS octets) of between 64 and 1518 octets, inclusive, but had either a bad FCS with an integral number of octets (FCS Error) or a bad FCS with a nonintegral number of octets (Alignment Error).
etherStatsDropEvents ²	Number of received frames dropped at the port level.
rxPauseFrames ¹	Number of received pause frames.
txPauseFrames ¹	Number of transmitted pause frames.
rxPktsDroppedInternalCongestion ¹	Number of received packets dropped due to overflow in frame buffer.
txPktsDroppedInternalCongestion ¹	Number of transmit queue drops due to drops in frame buffer.
rxControlFrames ¹	Number of received control frames.
mediaIndStatsRxFramesTruncated ¹	Number of received frames with length of 36 bytes or less.
mediaIndStatsRxFramesTooLong ¹	Number of received frames that are too long. The maximum is the programmed maximum frame size (for VSAN support); if the maximum frame size is set to default, then the maximum is the 2112 byte payload plus the 36 byte header, which is a total of 2148 bytes.
mediaIndStatsRxFramesBadCRC ¹	Number of received frames with CRC error.
mediaIndStatsTxFramesBadCRC ¹	Number of transmitted frames with CRC error.
mediaIndStatsRxShortPackets ¹	Number of received packets that are too small.

1. For CE1000-4 only

2. For CE100T-8 only

15.6.4.2 CE-Series Card Ether Ports Utilization Window

The Ether Ports Utilization window shows the percentage of Tx and Rx line bandwidth used by the Ethernet ports during consecutive time segments. The Utilization window provides an Interval drop-down list that enables you to set time intervals of 1 minute, 15 minutes, 1 hour, and 1 day. Line utilization is calculated with the following formulas:

$$Rx = (\text{inOctets} + \text{inPkts} * 20) * 8 / 100\% \text{ interval} * \text{maxBaseRate}$$

$$Tx = (\text{outOctets} + \text{outPkts} * 20) * 8 / 100\% \text{ interval} * \text{maxBaseRate}$$

The interval is defined in seconds. The maxBaseRate is defined by raw bits per second in one direction for the Ethernet port (that is, 1 Gbps). The maxBaseRate for CE-Series Ethernet cards is shown in [Table 15-14](#).



Note

Line utilization numbers express the average of ingress and egress traffic as a percentage of capacity.

15.6.4.3 CE-Series Card Ether Ports History Window

The Ethernet Ether Ports History window lists past Ethernet statistics for the previous time intervals. Depending on the selected time interval, the History window displays the statistics for each port for the number of previous time intervals as shown in [Table 15-15 on page 15-31](#). The listed parameters are defined in [Table 15-16 on page 15-32](#).

15.6.4.4 CE-Series Card POS Ports Statistics Parameters

The Ethernet POS Ports statistics window lists Ethernet POS parameters at the line level. [Table 15-21](#) defines the CE-Series Ethernet card POS Ports parameters.

Table 15-21 CE-Series Card POS Ports Parameters

Parameter	Definition
Time Last Cleared	A time stamp indicating the last time that statistics were reset.
Link Status	Indicates whether the Ethernet link is receiving a valid Ethernet signal (carrier) from the attached Ethernet device; up means present, and down means not present.
ifInOctets	Number of bytes received since the last counter reset.
rxTotalPkts	Number of received packets.
ifInDiscards ¹	The number of inbound packets that were chosen to be discarded even though no errors had been detected to prevent their being deliverable to a higher-layer protocol. One possible reason for discarding such a packet could be to free buffer space.
ifInErrors ¹	The number of inbound packets (or transmission units) that contained errors preventing them from being deliverable to a higher-layer protocol.
ifOutOctets	Number of bytes transmitted since the last counter reset.
txTotalPkts	Number of transmitted packets.
ifOutOversizePkts ¹	Packets greater than 1518 bytes transmitted out a port.
gfpStatsRxFrame ²	Number of received GFP frames.

Table 15-21 CE-Series Card POS Ports Parameters (continued)

Parameter	Definition
gfpStatsTxFrame ²	Number of transmitted GFP frames.
gfpStatsRxCRCErrors	Number of packets received with a payload FCS error.
gfpStatsRxOctets ²	Number of GFP bytes received.
gfpStatsTxOctets ²	Number of GFP bytes transmitted.
gfpStatsRxSBitErrors	Sum of all the single bit errors. In the GFP CORE HDR at the GFP-T receiver, these are correctable.
gfpStatsRxMBitErrors	Sum of all the multiple bit errors. In the GFP CORE HDR at the GFP-T receiver, these are uncorrectable.
gfpStatsRxTypeInvalid	Number of receive packets dropped due to Client Data Frame UPI errors.
gfpStatsRxCIDInvalid ¹	Number of packets with invalid CID.
gfpStatsCSFRaised	Number of GFP Client signal fail frames detected at the GFP-T receiver.
ifInPayloadCrcErrors ¹	Received payload CRC errors.
ifOutPayloadCrcErrors ¹	Transmitted payload CRC errors.
hdlcPktDrops	Number of received packets dropped before input.

1. Applicable only for CE100T-8

2. Applicable only for CE1000-4

15.6.4.5 CE-Series Card POS Ports Utilization Window

The POS Ports Utilization window shows the percentage of Tx and Rx line bandwidth used by the POS ports during consecutive time segments. The Utilization window provides an Interval drop-down list that enables you to set time intervals of 1 minute, 15 minutes, 1 hour, and 1 day. Line utilization is calculated with the following formulas:

$$Rx = (\text{inOctets} * 8) / (\text{interval} * \text{maxBaseRate})$$

$$Tx = (\text{outOctets} * 8) / (\text{interval} * \text{maxBaseRate})$$

The interval is defined in seconds. The maxBaseRate is defined by raw bits per second in one direction for the Ethernet port (that is, 1 Gbps). The maxBaseRate for CE-Series cards is shown in [Table 15-14 on page 15-31](#).



Note

Line utilization numbers express the average of ingress and egress traffic as a percentage of capacity.

15.6.4.6 CE-Series Card Ether Ports History Window

The Ethernet POS Ports History window lists past Ethernet POS ports statistics for the previous time intervals. Depending on the selected time interval, the History window displays the statistics for each port for the number of previous time intervals as shown in [Table 15-15 on page 15-31](#). The listed parameters are defined in [Table 15-20 on page 15-37](#).

15.7 Performance Monitoring for Optical Cards

This section lists PM parameters for ONS 15454 optical cards, including the OC-3, OC-12, OC-48, and OC-192 cards. Figure 15-20 shows the signal types that support near-end and far-end PMs.

Figure 15-20 Monitored Signal Types for the OC-3 Cards

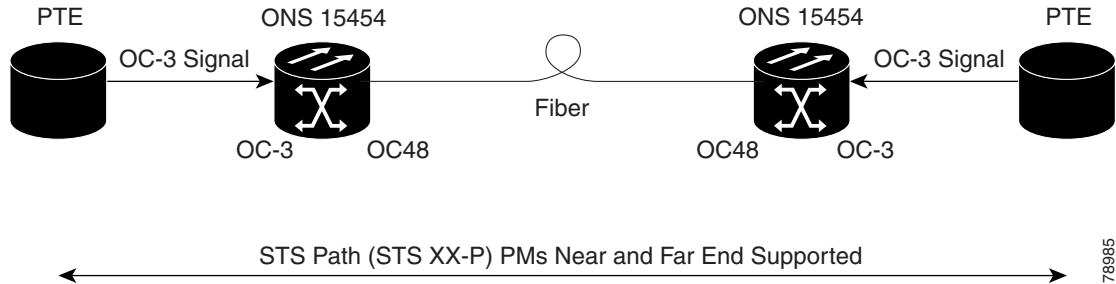

Note

The XX in Figure 15-20 represents all PMs listed in Table 15-22, Table 15-23, and Table 15-24 with the given prefix and/or suffix.

Figure 15-21 shows where overhead bytes detected on the ASICs produce PM parameters for the OC3 IR 4 SH 1310 and OC3 IR SH 1310-8 cards.

Figure 15-21 PM Read Points on the OC-3 Cards

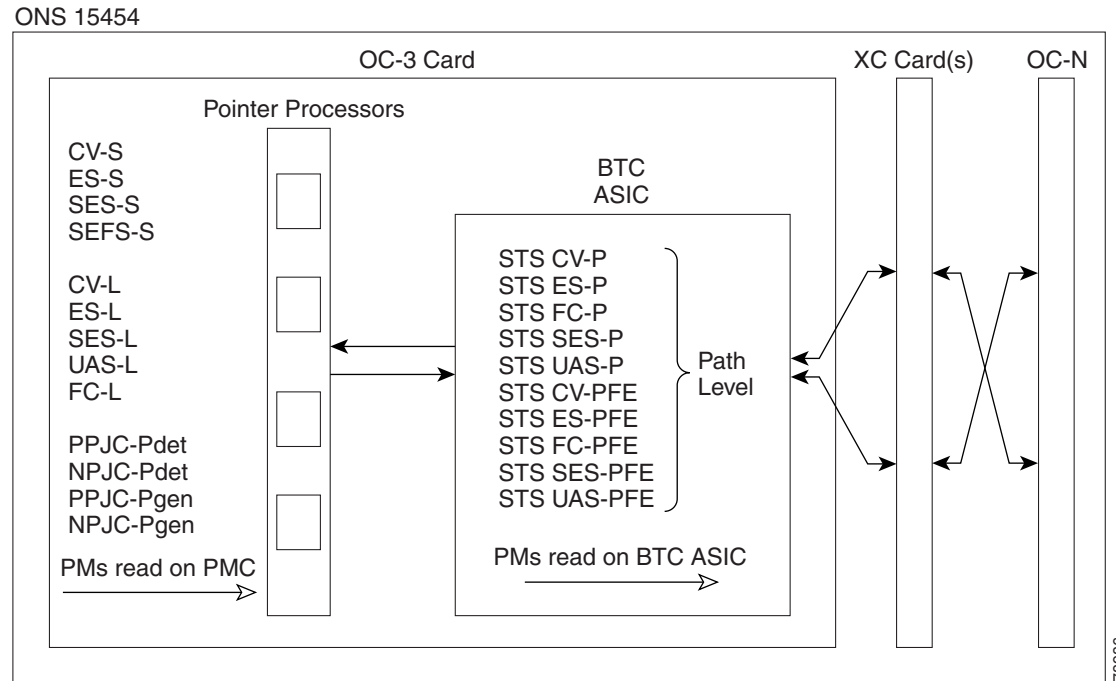

Note

For PM locations relating to protection switch counts, see the Telcordia GR-253-CORE document.

Table 15-22 and Table 15-23 list the PM parameters for OC-3 cards.

Table 15-22 OC-3 Card PMs

Section (NE)	Line (NE)	STS Path (NE)	Line (FE)	STS Path (FE) ¹
CV-S	CV-L	CV-P	CV-LFE	CV-PFE
ES-S	ES-L	ES-P	ES-LFE	ES-PFE
SES-S	SES-L	SES-P	SES-LFE	SES-PFE
SEF-S	UAS-L	UAS-P	UAS-LFE	UAS-PFE
	FC-L	FC-P	FC-LFE	FC-PFE
	PSC (1+1)	PPJC-PDET		
	PSD (1+1)	NPJC-PDET		
		PPJC-PGEN		
		NPJC-PGEN		
		PPJC-PDET-P		
		PPJC-PGEN-P		
		PJC-DIFF		

1. The STS Path (FE) PMs are valid only for the OC3-4 card on ONS 15454.

Table 15-23 OC3-8 Card PMs

Section (NE)	Line (NE)	Physical Layer (NE)	STS Path (NE)	Line (FE)	STS Path (FE)
CV-S	CV-L	LBCL	CV-P	CV-LFE	CV-PFE
ES-S	ES-L	OPT	ES-P	ES-LFE	ES-PFE
SES-S	SES-L	OPR	SES-P	SES-LFE	SES-PFE
SEF-S	UAS-L		UAS-P	UAS-LFE	UAS-PFE
	FC-L		FC-P	FC-LFE	FC-PFE
	PSC (1+1)		PPJC-PDET-P		
	PSD (1+1)		NPJC-PDET-P		
			PPJC-PGEN-P		
			NPJC-PGEN-P		
			PJCS-PDET-P		
			PJCS-PGEN-P		
			PJC-DIFF-P		

Table 15-24 lists the PM parameters for OC-12, OC-48, and OC-192 cards.

Table 15-24 OC-12, OC-48, OC-192 Card PMs

Section (NE)	Line (NE)	STS Path (NE)	Line (FE)
CV-S	CV-L	CV-P	CV-L
ES-S	ES-L	ES-P	ES-L
SES-S	SES--L	SES-P	SES-L
SEF-S	UASL	UAS-P	UAS-L
	FC-L	FC-P	FC-L
	PSC (1+1, 2F BLSR)	PPJC-PDET-P	
	PSD (1+1, 2F BLSR)	NPJC-PDET-P	
	PSC-W (4F BLSR)	PPJC-PGEN-P	
	PSD-W (4F BLSR)	NPJC-PGEN-P	
	PSC-S (4F BLSR)	PJCS-PGEN-P	
	PSD-S (4F BLSR)	PJCS-PDET-P	
	PSC-R (4F BLSR)	PJC-DIFF-P	
	PSD-R (4F BLSR)		

15.8 Performance Monitoring for Optical Multirate Cards

This section lists PM parameters for the optical multirate card, also known as the MRC-12 card.

Figure 15-22 shows where overhead bytes detected on the ASICs produce PM parameters for the MRC-12 card.

Figure 15-22 PM Read Points for the MRC-12 Card

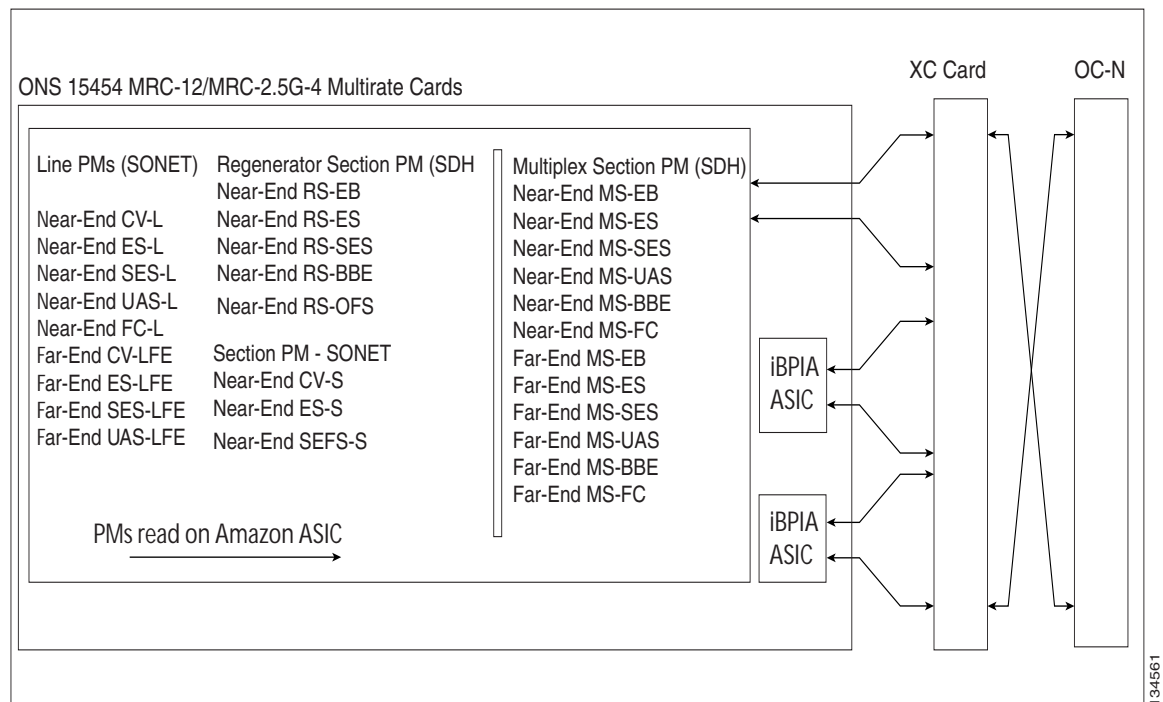

Table 15-25 lists the PM parameters for MRC-12 card.

Table 15-25 MRC Card PMs

Section (NE)	Line (NE)	Physical Layer (NE)	STS Path (NE)	Line (FE)	STS Path (FE)
CV-S	CV-L	LBC	CV-P	CV-LFE	CV-PFE
ES-S	ES-L	OPT	ES-P	ES-LFE	ES-PFE
SES-S	SES-L	OPR	SES-P	SES-LFE	SES-PFE
SEF-S	UAS-L		UAS-P	UAS-LFE	UAS-PFE
	FC-L		FC-P	FC-LFE	FC-PFE
	PSC (1+1)		PPJC-PDET-P		
	PSD (1+1)		NPJC-PDET-P		
			PPJC-PGEN-P		
			NPJC-PGEN-P		
			PJCS-PDET-P		
			PJCS-PGEN-P		
			PJC-DIFF-P		

15.9 Performance Monitoring for Storage Access Networking Cards

The following sections define PM parameters and definitions for the SAN card, also known as the FC_MR-4 or Fibre Channel card.

CTC provides FC_MR-4 performance information, including line-level parameters, port bandwidth consumption, and historical statistics. The FC_MR-4 card performance information is divided into the Statistics, Utilization, and History tabbed windows within the card view Performance tab window.

15.9.1 FC_MR-4 Statistics Window

The Statistics window lists parameters at the line level. The Statistics window provides buttons to change the statistical values shown. The Baseline button resets the displayed statistics values to zero. The Refresh button manually refreshes statistics. Auto-Refresh sets a time interval at which automatic refresh occurs. The Statistics window also has a Clear button. The Clear button sets the values on the card to zero. All counters on the card are cleared. [Table 15-26](#) defines the FC_MR-4 card statistics parameters.

Table 15-26 FC_MR-4 Card Statistics

Parameter	Definition
Time Last Cleared	Time stamp indicating the time at which the statistics were last reset.
Link Status	Indicates whether the Fibre Channel link is receiving a valid Fibre Channel signal (carrier) from the attached Fibre Channel device; up means present, and down means not present.
ifInOctets	Number of bytes received without error for the Fibre Channel payload.

Table 15-26 FC_MR-4 Card Statistics

Parameter	Definition
rxTotalPkts	Number of Fibre Channel frames received without errors.
ifInDiscards	Number of inbound packets that were chosen to be discarded even though no errors had been detected to prevent their being deliverable to a higher-layer protocol. One possible reason for discarding such a packet could be to free up buffer space.
ifInErrors	Sum of frames that are oversized, undersized, or with cyclic redundancy check (CRC) error.
ifOutOctets	Number of bytes transmitted without error for the Fibre Channel payload.
txTotalPkts	Number of Fibre Channel frames transmitted without errors.
ifOutDiscards	Number of outbound packets which were chosen to be discarded even though no errors had been detected to prevent their transmission. A possible reason for discarding such packets could be to free up buffer space.
gfpStatsRxSBitErrors	Number of single bit errors in core header error check (CHEC).
gfpStatsRxMBitErrors	Number of multiple bit errors in CHEC.
gfpStatsRxTypeInvalid	Number of invalid generic framing procedure (GFP) type field received. This includes unexpected user payload identifier (UPI) type and also errors in CHEC.
gfpStatsRxSblkCRCErrors	Number of super block CRC errors.
gfpStatsRoundTripLatencyUsec	Round trip delay for the end-to-end Fibre Channel transport in milli seconds.
gfpStatsRxDistanceExtBuffers	Number of buffer credit received for GFP-T receiver (valid only if distance extension is enabled).
gfpStatsTxDistanceExtBuffers	Number of buffer credit transmitted for GFP-T transmitter (valid only if distance extension is enabled).
mediaIndStatsRxFramesTruncated	Number of Fibre Channel frames received with frame size <= 36 bytes.
mediaIndStatsRxFramesTooLong	Number of Fibre Channel frames received with frame size higher than the provisioned maximum frame size.
mediaIndStatsRxFramesBadCRC	Number of Fibre Channel frames received with bad CRC.

Table 15-26 FC_MR-4 Card Statistics

Parameter	Definition
mediaIndStatsTxFramesBadCRC	Number of Fibre Channel frames transmitted with bad CRC.
fcStatsLinkRecoveries	Number of link recoveries.
fcStatsRxCredits	Number of buffers received to buffer credits T (valid only if distance extension is enable).
fcStatsTxCredits	Number of buffers transmitted to buffer credits T (valid only if distance extension is enable).
fcStatsZeroTxCredits	Number of transmit attempts that failed because of unavailable credits.
8b10bInvalidOrderedSets	8b10b loss of sync count on Fibre Channel line side.
8b10bStatsEncodingDispErrors	8b10b disparity violations count on Fibre Channel line side.
gfpStatsCSFRaised	Number of GFP Client Signal Fail frames detected.

15.9.2 FC_MR-4 Utilization Window

The Utilization window shows the percentage of Tx and Rx line bandwidth used by the ports during consecutive time segments. The Utilization window provides an Interval drop-down list that enables you to set time intervals of 1 minute, 15 minutes, 1 hour, and 1 day. Line utilization is calculated with the following formulas:

$$Rx = (inOctets + inPkts * 24) * 8 / 100\% \text{ interval} * \text{maxBaseRate}$$

$$Tx = (outOctets + outPkts * 24) * 8 / 100\% \text{ interval} * \text{maxBaseRate}$$

The interval is defined in seconds. The maxBaseRate is defined by raw bits per second in one direction for the port (that is, 1 Gbps or 2 Gbps). The maxBaseRate for FC_MR-4 cards is shown in [Table 15-27](#).

Table 15-27 maxBaseRate for STS Circuits

STS	maxBaseRate
STS-24	850000000
STS-48	850000000 x 2 ¹

- For 1 Gbps of bit rate being transported, there are only 850 Mbps of actual data because of 8b->10b conversion. Similarly, for 2 Gbps of bit rate being transported, there are only 1700 Mbps (850 Mbps x 2) of actual data.

**Note**

Line utilization numbers express the average of ingress and egress traffic as a percentage of capacity.

15.9.3 FC_MR-4 History Window

The History window lists past FC_MR-4 statistics for the previous time intervals. Depending on the selected time interval, the History window displays the statistics for each port for the number of previous time intervals as shown in [Table 15-28](#). The listed parameters are defined in [Table 15-26 on page 15-45](#).

Table 15-28 *FC_MR-4 History Statistics per Time Interval*

Time Interval	Number of Intervals Displayed
1 minute	60 previous time intervals
15 minutes	32 previous time intervals
1 hour	24 previous time intervals
1 day (24 hours)	7 previous time intervals



CHAPTER 16

SNMP

This chapter explains Simple Network Management Protocol (SNMP) as implemented by the Cisco ONS 15454.

For SNMP setup information, refer to the *Cisco ONS 15454 Procedure Guide*.

Chapter topics include:

- [16.1 SNMP Overview, page 16-1](#)
- [16.2 Basic SNMP Components, page 16-2](#)
- [16.3 SNMP External Interface Requirement, page 16-4](#)
- [16.4 SNMP Version Support, page 16-4](#)
- [16.5 SNMP Message Types, page 16-4](#)
- [16.6 SNMP Management Information Bases, page 16-5](#)
- [16.7 SNMP Trap Content, page 16-8](#)
- [16.8 SNMP Community Names, page 16-16](#)
- [16.9 Proxy Over Firewalls, page 16-16](#)
- [16.10 Remote Monitoring, page 16-16](#)

16.1 SNMP Overview

SNMP is an application-layer communication protocol that allows ONS 15454 network devices to exchange management information among these systems and with other devices outside the network. Through SNMP, network administrators can manage network performance, find and solve network problems, and plan network growth. Up to 10 SNMP trap destinations and five concurrent CTC user sessions are allowed per node.

The ONS 15454 uses SNMP for asynchronous event notification to a network management system (NMS). ONS SNMP implementation uses standard Internet Engineering Task Force (IETF) management information bases (MIBs) to convey node-level inventory, fault, and performance management information for generic read-only management of DS-1, DS-3, SONET, and Ethernet technologies. SNMP allows a generic SNMP manager such as HP OpenView Network Node Manager (NNM) or Open Systems Interconnection (OSI) NetExpert to be utilized for limited management functions.

The Cisco ONS 15454 supports SNMP Version 1 (SNMPv1) and SNMP Version 2c (SNMPv2c). These versions share many features, but SNMPv2c includes additional protocol operations and 64-bit performance monitoring support. This chapter describes both versions and gives SNMP configuration parameters for the ONS 15454.

**Note**

It is recommended that the SNMP Manager timeout value be set to 60 seconds. Under certain conditions, if this value is lower than the recommended time, the TCC card can reset. However, the response time depends on various parameters such as object being queried, complexity, and number of hops in the node, etc.

**Note**

The CERENT-MSDWDM-MIB.mib, CERENT-FC-MIB.mib, and CERENT-GENERIC-PM-MIB.mib in the CiscoV2 directory support 64-bit performance monitoring counters. The SNMPv1 MIB in the CiscoV1 directory does not contain 64-bit performance monitoring counters, but supports the lower and higher word values of the corresponding 64-bit counter. The other MIB files in the CiscoV1 and CiscoV2 directories are identical in content and differ only in format.

Figure 16-1 illustrates the basic layout idea of an SNMP-managed network.

Figure 16-1 Basic Network Managed by SNMP

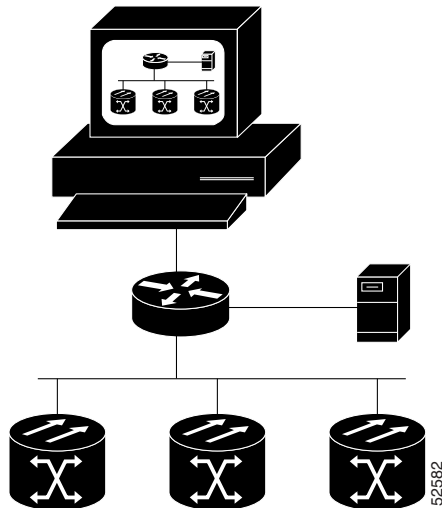

16.2 Basic SNMP Components

In general terms, an SNMP-managed network consists of a management system, agents, and managed devices.

A management system such as HP OpenView executes monitoring applications and controls managed devices. Management systems execute most of the management processes and provide the bulk of memory resources used for network management. A network might be managed by one or more management systems. Figure 16-2 illustrates the relationship between the network manager, the SNMP agent, and the managed devices.

Figure 16-2 Example of the Primary SNMP Components

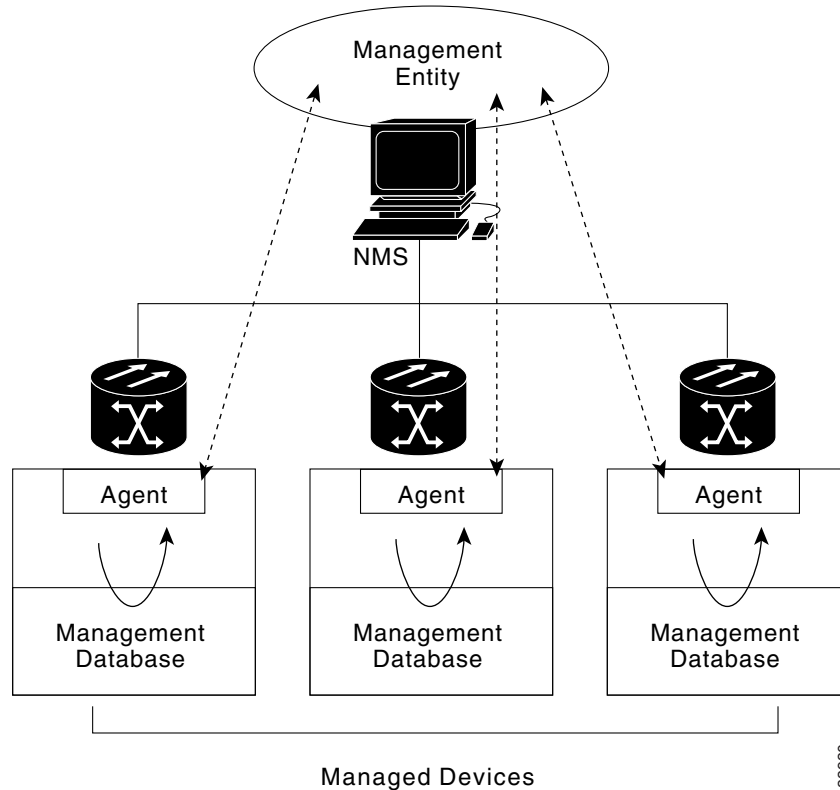

An agent (such as SNMP) residing on each managed device translates local management information data, such as performance information or event and error information caught in software traps, into a readable form for the management system. [Figure 16-3](#) illustrates SNMP agent get-requests that transport data to the network management software.

Figure 16-3 Agent Gathering Data from a MIB and Sending Traps to the Manager

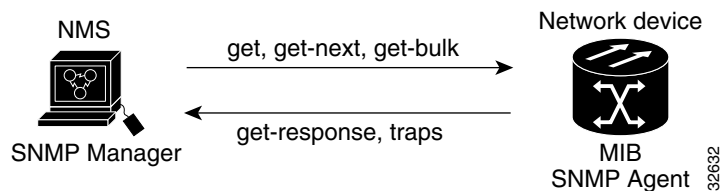

The SNMP agent captures data from MIBs, which are device parameter and network data repositories, or from error or change traps.

A managed element—such as a router, access server, switch, bridge, hub, computer host, or network element (such as an ONS 15454)—is accessed through the SNMP agent. Managed devices collect and store management information, making it available through SNMP to other management systems having the same protocol compatibility.

16.3 SNMP External Interface Requirement

Since all SNMP requests come from a third-party application, the only external interface requirement is that a third-part SNMP client application can upload RFC 3273 SNMP MIB variables in the etherStatsHighCapacityTable, etherHistoryHighCapacityTable, or mediaIndependentTable.

16.4 SNMP Version Support

The ONS 15454 supports SNMPv1 and SNMPv2c traps and get requests. The ONS 15454 SNMP MIBs define alarms, traps, and status. Through SNMP, NMS applications can query a management agent for data from functional entities such as Ethernet switches and SONET multiplexers using a supported MIB.



Note

ONS 15454 MIB files in the CiscoV1 and CiscoV2 directories are almost identical in content except for the difference in 64-bit performance monitoring features. The CiscoV2 directory contains three MIBs with 64-bit performance monitoring counters: CERENT-MSDWDM-MIB.mib, CERENT-FC-MIB.mib, and CERENT-GENERIC-PM-MIB.mib. The CiscoV1 directory does not contain any 64-bit counters, but it does support the lower and higher word values used in 64-bit counters. The two directories also have somewhat different formats.

16.5 SNMP Message Types

The ONS 15454 SNMP agent communicates with an SNMP management application using SNMP messages. [Table 16-1](#) describes these messages.

Table 16-1 ONS 15454 SNMP Message Types

Operation	Description
get-request	Retrieves a value from a specific variable.
get-next-request	Retrieves the value following the named variable; this operation is often used to retrieve variables from within a table. With this operation, an SNMP manager does not need to know the exact variable name. The SNMP manager searches sequentially to find the needed variable from within the MIB.
get-response	Replies to a get-request, get-next-request, get-bulk-request, or set-request sent by an NMS.
get-bulk-request	Fills the get-response with up to the max-repetition number of get-next interactions, similar to a get-next-request.
set-request	Provides remote network monitoring (RMON) MIB.
trap	Indicates that an event has occurred. An unsolicited message is sent by an SNMP agent to an SNMP manager.

16.6 SNMP Management Information Bases

Section 16.6.1 lists IETF-standard MIBs that are implemented in the ONS 15454 and shows their compilation order. Section 16.6.2 lists proprietary MIBs for the ONS 15454 and shows their compilation order. Section 16.6.3 contains information about the generic threshold and performance monitoring MIBs that can be used to monitor any network element (NE) contained in the network.

16.6.1 IETF-Standard MIBs for the ONS 15454

Table 16-2 lists the IETF-standard MIBs implemented in the ONS 15454 SNMP agents.

First compile the MIBs in Table 16-2. Compile the Table 16-3 MIBs next.



Caution

If you do not compile MIBs in the correct order, one or more might not compile correctly.

Table 16-2 IETF Standard MIBs Implemented in the ONS 15454 System

RFC ¹ Number	Module Name	Title/Comments
—	IANAifType-MIB.mib	Internet Assigned Numbers Authority (IANA) ifType
1213	RFC1213-MIB-rfc1213.mib	Management Information Base for Network
1907	SNMPV2-MIB-rfc1907.mib	Management of TCP/IP-based Internets: MIB-II Management Information Base for Version 2 of the Simple Network Management Protocol (SNMPv2)
1253	RFC1253-MIB-rfc1253.mib	OSPF Version 2 Management Information Base
1493	BRIDGE-MIB-rfc1493.mib	Definitions of Managed Objects for Bridges (This defines MIB objects for managing MAC bridges based on the IEEE 802.1D-1990 standard between Local Area Network [LAN] segments.)
2819	RMON-MIB-rfc2819.mib	Remote Network Monitoring Management Information Base
2737	ENTITY-MIB-rfc2737.mib	Entity MIB (Version 2)
2233	IF-MIB-rfc2233.mib	Interfaces Group MIB using SNMPv2
2358	EtherLike-MIB-rfc2358.mib	Definitions of Managed Objects for the Ethernet-like Interface Types
2493	PerfHist-TC-MIB-rfc2493.mib	Textual Conventions for MIB Modules Using Performance History Based on 15 Minute Intervals
2495	DS1-MIB-rfc2495.mib	Definitions of Managed Objects for the DS1, E1, DS2 and E2 Interface Types
2496	DS3-MIB-rfc2496.mib	Definitions of Managed Object for the DS3/E3 Interface Type
2558	SONET-MIB-rfc2558.mib	Definitions of Managed Objects for the SONET/SDH Interface Type

Table 16-2 IETF Standard MIBs Implemented in the ONS 15454 System (continued)

RFC ¹ Number	Module Name	Title/Comments
2674	P-BRIDGE-MIB-rfc2674.mib Q-BRIDGE-MIB-rfc2674.mib	Definitions of Managed Objects for Bridges with Traffic Classes, Multicast Filtering and Virtual LAN Extensions
3273	HC-RMON-MIB	The MIB module for managing remote monitoring device implementations, augmenting the original RMON MIB as specified in RFC 2819 and RFC 1513 and RMON-2 MIB as specified in RFC 2021

1. RFC = Request for Comment

16.6.2 Proprietary ONS 15454 MIBs

Each ONS 15454 is shipped with a software CD containing applicable proprietary MIBs. [Table 16-3](#) lists the proprietary MIBs for the ONS 15454.

Table 16-3 ONS 15454 Proprietary MIBs

MIB Number	Module Name
1	CERENT-GLOBAL-REGISTRY.mib
2	CERENT-TC.mib
3	CERENT-454.mib
4	CERENT-GENERIC.mib (not applicable to ONS 15454)
5	CISCO-SMI.mib
6	CISCO-VOA-MIB.mib
7	CERENT-MSDWDM-MIB.mib
8	CISCO-OPTICAL-MONITOR-MIB.mib
9	CERENT-HC-RMON-MIB.mib
10	CERENT-ENVMON-MIB.mib
11	CERENT-GENERIC-PM-MIB.mib

**Note**

If you cannot compile the proprietary MIBs correctly, log into the Technical Support Website at <http://www.cisco.com/techsupport> or call Cisco TAC (800) 553-2447.

**Note**

When SNMP indicates that the wavelength is unknown, it means that the corresponding card (MXP_2.5G_10E, TXP_MR_10E, MXP_2.5G_10G, TXP_MR_10G, TXP_MR_2.5G, or TXPP_MR_2.5G) works with the first tunable wavelength. For more information about MXP and TXP cards, refer to the *Cisco ONS 15454 DWDM Reference Manual*.

16.6.3 Generic Threshold and Performance Monitoring MIBs

In Release 7.0, a MIB called CERENT-GENERIC-PM-MIB allows network management stations (NMS) to use a single, generic MIB for accessing threshold and performance monitoring data of different interface types. The MIB is generic in the sense that it is not tied to any particular kind of interface. The MIB objects can be used to obtain threshold values, current performance monitoring (PM) counts, and historic PM statistics for each kind of monitor and any supported interval at the near end and far end.

Previously existing MIBs in the ONS 15454 system provide some of these counts. For example, SONET interface 15-minute current PM counts and historic PM statistics are available using the SONET-MIB. DS-1 and DS-3 counts and statistics are available through the DS1-MIB and DS-3 MIB respectively. The generic MIB provides these types of information and also fetches threshold values and single-day statistics. In addition, the MIB supports optics and dense wavelength division multiplexing (DWDM) threshold and performance monitoring information.

The CERENT-GENERIC-PM-MIB is organized into three different tables:

- `cerentGenericPmThresholdTable`
- `cerentGenericPmStatsCurrentTable`
- `cerentGenericPmStatsIntervalTable`

The `cerentGenericPmThresholdTable` is used to obtain the threshold values for the monitor types. It is indexed based on the interface index (`cerentGenericPmThresholdIndex`), monitor type (`cerentGenericPmThresholdMonType`), location (`cerentGenericPmThresholdLocation`), and time period (`cerentGenericPmThresholdPeriod`). The syntax of `cerentGenericPmThresholdMonType` is type `cerentMonitorType`, defined in CERENT-TC.mib. The syntax of `cerentGenericPmThresholdLocation` is type `cerentLocation`, defined in CERENT-TC.mib. The syntax of `cerentGenericPmThresholdPeriod` is type `cerentPeriod`, defined in CERENT-TC.mib.

Threshold values can be provided in 64-bit and 32-bit formats. (For more information about 64-bit counters, see the “[16.10.2 HC-RMON-MIB Support](#)” section on page 16-18.) The 64-bit values in `cerentGenericPmThresholdHCValue` can be used with agents that support SNMPv2. The two 32-bit values (`cerentGenericPmThresholdValue` and `cerentGenericPmThresholdOverFlowValue`) can be used by NMSs that only support SNMPv1. The objects compiled in the `cerentGenericPmThresholdTable` are shown in [Table 16-4](#).

Table 16-4 *cerentGenericPmThresholdTable*

Index Objects	Information Objects
<code>cerentGenericPmThresholdIndex</code>	<code>cerentGenericPmThresholdValue</code>
<code>cerentGenericPmThresholdMonType</code>	<code>cerentGenericPmThresholdOverFlowValue</code>
<code>cerentGenericPmThresholdLocation</code>	<code>cerentGenericPmThresholdHCValue</code>
<code>cerentGenericPmThresholdPeriod</code>	—

The second table within the MIB, `cerentGenericPmStatsCurrentTable`, compiles the current performance monitoring (PM) values for the monitor types. The table is indexed based on interface index (`cerentGenericPmStatsCurrentIndex`), monitor type (`cerentGenericPmStatsCurrentMonType`), location (`cerentGenericPmStatsCurrentLocation`) and time period (`cerentGenericPmStatsCurrentPeriod`). The syntax of `cerentGenericPmStatsCurrentIndex` is type `cerentLocation`, defined in CERENT-TC.mib. The syntax of `cerentGenericPmStatsCurrentMonType` is type `cerentMonitor`, defined in CERENT-TC.mib. The syntax of `cerentGenericPmStatsCurrentPeriod` is type `cerentPeriod`, defined in CERENT-TC.mib.

The `cerentGenericPmStatsCurrentTable` validates the current PM value using the `cerentGenericPmStatsCurrentValid` object and registers the number of valid intervals with historical PM statistics in the `cerentGenericPmStatsCurrentValidIntervals` object.

PM values are provided in 64-bit and 32-bit formats. The 64-bit values in `cerentGenericPmStatsCurrentHCValue` can be used with agents that support SNMPv2. The two 32-bit values (`cerentGenericPmStatsCurrentValue` and `cerentGenericPmStatsCurrentOverFlowValue`) can be used by NMS that only support SNMPv1. The `cerentGenericPmStatsCurrentTable` is shown in [Table 16-5](#).

Table 16-5 *cerentGenericPmStatsCurrentTable*

Index Objects	Informational Objects
<code>cerentGenericPmStatsCurrentIndex</code>	<code>cerentGenericPmStatsCurrentValue</code>
<code>cerentGenericPmStatsCurrentMonType</code>	<code>cerentGenericPmStatsCurrentOverFlowValue</code>
<code>cerentGenericPmStatsCurrentLocation</code>	<code>cerentGenericPmStatsCurrentHCValue</code>
<code>cerentGenericPmStatsCurrentPeriod</code>	<code>cerentGenericPmStatsCurrentValidData</code>
—	<code>cerentGenericPmStatsCurrentValidIntervals</code>

The third table in the MIB, `cerentGenericPmStatsIntervalTable`, obtains historic PM values for the monitor types. This table is indexed based on the interface index, monitor type, location, time period, and interval number. It validates the current PM value in the `cerentGenericPmStatsIntervalValid` object.

This table is indexed based on interface index (`cerentGenericPmStatsIntervalIndex`), monitor type (`cerentGenericPmStatsIntervalMonType`), location (`cerentGenericPmStatsIntervalLocation`), and period (`cerentGenericPmStatsIntervalPeriod`). The syntax of `cerentGenericPmStatsIntervalIndex` is type `cerentLocation`, defined in `CERENT-TC.mib`. The syntax of `cerentGenericPmStatsIntervalMonType` is type `cerentMonitor`, defined in `CERENT-TC.mib`. The syntax of `cerentGenericPmStatsIntervalPeriod` is type `cerentPeriod`, defined in `CERENT-TC.mib`.

The table provides historic PM values in 64-bit and 32-bit formats. The 64-bit values contained in the `cerentGenericPmStatsIntervalHCValue` table can be used with SNMPv2 agents. The two 32-bit values (`cerentGenericPmStatsIntervalValue` and `cerentGenericPmStatsIntervalOverFlowValue`) can be used by SNMPv1 NMS. The `cerentGenericPmStatsIntervalTable` is shown in [Table 16-6](#).

Table 16-6 *cerentGenericPmStatsIntervalTable*

Index Objects	Informational Objects
<code>cerentGenericPmStatsIntervalIndex</code>	<code>cerentGenericPmStatsIntervalValue</code>
<code>cerentGenericPmStatsIntervalMonType</code>	<code>cerentGenericPmStatsIntervalOverFlowValue</code>
<code>cerentGenericPmStatsIntervalLocation</code>	<code>cerentGenericPmStatsIntervalHCValue</code>
<code>cerentGenericPmStatsIntervalPeriod</code>	<code>cerentGenericPmStatsIntervalValidData</code>
<code>cerentGenericPmStatsIntervalNumber</code>	—

16.7 SNMP Trap Content

The ONS 15454 generates all alarms and events, such as raises and clears, as SNMP traps. These contain the following information:

- Object IDs that uniquely identify each event with information about the generating entity (the slot or port; synchronous transport signal [STS] and Virtual Tributary [VT]; bidirectional line switched ring [BLSR], Spanning Tree Protocol [STP], etc.).
- Severity and service effect of the alarm (critical, major, minor, or event; service-affecting or non-service-affecting).
- Date and time stamp showing when the alarm occurred.

16.7.1 Generic and IETF Traps

The ONS 15454 supports the generic IETF traps listed in [Table 16-7](#).

Table 16-7 **Generic IETF Traps**

Trap	From RFC No. MIB	Description
coldStart	RFC1907-MIB	Agent up, cold start.
warmStart	RFC1907-MIB	Agent up, warm start.
authenticationFailure	RFC1907-MIB	Community string does not match.
newRoot	RFC1493/ BRIDGE-MIB	Sending agent is the new root of the spanning tree.
topologyChange	RFC1493/ BRIDGE-MIB	A port in a bridge has changed from Learning to Forwarding or Forwarding to Blocking.
entConfigChange	RFC2737/ ENTITY-MIB	The entLastChangeTime value has changed.
dsx1LineStatusChange	RFC2495/ DS1-MIB	The value of an instance of dsx1LineStatus has changed. The trap can be used by an NMS to trigger polls. When the line status change results from a higher-level line status change (for example, a DS-3), no traps for the DS-1 are sent.
dsx3LineStatusChange	RFC2496/ DS3-MIB	The value of an instance of dsx3LineStatus has changed. This trap can be used by an NMS to trigger polls. When the line status change results in a lower-level line status change (for example, a DS-1), no traps for the lower-level are sent.
risingAlarm	RFC2819/ RMON-MIB	The SNMP trap that is generated when an alarm entry crosses the rising threshold and the entry generates an event that is configured for sending SNMP traps.
fallingAlarm	RFC2819/ RMON-MIB	The SNMP trap that is generated when an alarm entry crosses the falling threshold and the entry generates an event that is configured for sending SNMP traps.

16.7.2 Variable Trap Bindings

Each SNMP trap contains variable bindings that are used to create the MIB tables. ONS 15454 traps and variable bindings are listed in [Table 16-8](#). For each group (such as Group A), all traps within the group are associated with all of its variable bindings.

Table 16-8 ONS 15454 SNMPv2 Trap Variable Bindings

Group	Trap Name(s) Associated with	Variable Binding Number	SNMPv2 Variable Bindings	Description
A	dsx1LineStatusChange (from RFC 2495)	(1)	dsx1LineStatus	This variable indicates the line status of the interface. It contains loopback, failure, received alarm and transmitted alarm information.
		(2)	dsx1LineStatusLastChange	The value of MIB II's sysUpTime object at the time this DS1 entered its current line status state. If the current state was entered prior to the last proxy-agent reinitialization, the value of this object is zero.
		(3)	cerent454NodeTime	The time that an event occurred.
		(4)	cerent454AlarmState	The alarm severity and service-affecting status. Severities are Minor, Major, and Critical. Service-affecting statuses are Service-Affecting and Non-Service Affecting.
		(5)	snmpTrapAddress	The address of the SNMP trap.
B	dsx3LineStatusChange (from RFC 2496)	(1)	dsx3LineStatus	This variable indicates the line status of the interface. It contains loopback state information and failure state information.
		(2)	dsx3LineStatusLastChange	The value of MIB II's sysUpTime object at the time this DS3/E3 entered its current line status state. If the current state was entered prior to the last reinitialization of the proxy-agent, then the value is zero.
		(3)	cerent454NodeTime	The time that an event occurred.

Table 16-8 ONS 15454 SNMPv2 Trap Variable Bindings (continued)

Group	Trap Name(s) Associated with	Variable Binding Number	SNMPv2 Variable Bindings	Description
B (cont.)		(4)	cerent454AlarmState	The alarm severity and service-affecting status. Severities are Minor, Major, and Critical. Service-affecting statuses are Service-Affecting and Non-Service Affecting.
		(5)	snmpTrapAddress	The address of the SNMP trap.
C	coldStart (from RFC 1907)	(1)	cerent454NodeTime	The time that the event occurred.
	warmStart (from RFC 1907)	(2)	cerent454AlarmState	The alarm severity and service-affecting status. Severities are Minor, Major, and Critical. Service-affecting statuses are Service-Affecting and Non-Service Affecting.
	newRoot (from RFC)	(3)	snmpTrapAddress	The address of the SNMP trap.
	topologyChange (from RFC)		—	—
	entConfigChange (from RFC 2737)		—	—
	authenticationFailure (from RFC 1907)		—	—
D1	risingAlarm (from RFC 2819)	(1)	alarmIndex	This variable uniquely identifies each entry in the alarm table. When an alarm in the table clears, the alarm indexes change for each alarm listed.
		(2)	alarmVariable	The object identifier of the variable being sampled.
		(3)	alarmSampleType	The method of sampling the selected variable and calculating the value to be compared against the thresholds.
		(4)	alarmValue	The value of the statistic during the last sampling period.

Table 16-8 ONS 15454 SNMPv2 Trap Variable Bindings (continued)

Group	Trap Name(s) Associated with	Variable Binding Number	SNMPv2 Variable Bindings	Description
D1 (cont.)		(5)	alarmRisingThreshold	When the current sampled value is greater than or equal to this threshold, and the value at the last sampling interval was less than this threshold, a single event is generated. A single event is also generated if the first sample after this entry is greater than or equal to this threshold.
		(6)	cerent454NodeTime	The time that an event occurred.
		(7)	cerent454AlarmState	The alarm severity and service-affecting status. Severities are Minor, Major, and Critical. Service-affecting statuses are Service-Affecting and Non-Service Affecting.
		(8)	snmpTrapAddress	The address of the SNMP trap.
D2	fallingAlarm (from RFC 2819)	(1)	alarmIndex	This variable uniquely identifies each entry in the alarm table. When an alarm in the table clears, the alarm indexes change for each alarm listed.
		(2)	alarmVariable	The object identifier of the variable being sampled.
		(3)	alarmSampleType	The method of sampling the selected variable and calculating the value to be compared against the thresholds.
		(4)	alarmValue	The value of the statistic during the last sampling period.
		(5)	alarmFallingThreshold	When the current sampled value is less than or equal to this threshold, and the value at the last sampling interval was greater than this threshold, a single event is generated. A single is also generated if the first sample after this entry is less than or equal to this threshold.
		(6)	cerent454NodeTime	The time that an event occurred.

Table 16-8 ONS 15454 SNMPv2 Trap Variable Bindings (continued)

Group	Trap Name(s) Associated with	Variable Binding Number	SNMPv2 Variable Bindings	Description
D2 (cont.)		(7)	cerent454AlarmState	The alarm severity and service-affecting status. Severities are Minor, Major, and Critical. Service-affecting statuses are Service-Affecting and Non-Service Affecting.
		(8)	snmpTrapAddress	The address of the SNMP trap.
E	failureDetectedExternalToTheNE (from CERENT-454-mib)	(1)	cerent454NodeTime	The time that an event occurred.
		(2)	cerent454AlarmState	The alarm severity and service-affecting status. Severities are Minor, Major, and Critical. Service-affecting statuses are Service-Affecting and Non-Service Affecting.
		(3)	cerent454AlarmObjectType	The entity that raised the alarm. The NMS should use this value to decide which table to poll for further information about the alarm.
		(4)	cerent454AlarmObjectIndex	Every alarm is raised by an object entry in a specific table. This variable is the index of objects in each table; if the alarm is interface-related, this is the index of the interface in the interface table.
		(5)	cerent454AlarmSlotNumber	The slot of the object that raised the alarm. If a slot is not relevant to the alarm, the slot number is zero.
		(6)	cerent454AlarmPortNumber	The port of the object that raised the alarm. If a port is not relevant to the alarm, the port number is zero.
		(7)	cerent454AlarmLineNumber	The object line that raised the alarm. If a line is not relevant to the alarm, the line number is zero.
		(8)	cerent454AlarmObjectName	The TL1-style user-visible name that uniquely identifies an object in the system.

Table 16-8 ONS 15454 SNMPv2 Trap Variable Bindings (continued)

Group	Trap Name(s) Associated with	Variable Binding Number	SNMPv2 Variable Bindings	Description
E (cont.)		(9)	cerent454AlarmAdditionalInfo	Additional information for the alarm object. In the current version of the MIB, this object contains provisioned description for alarms that are external to the NE. If there is no additional information, the value is zero.
		(10)	snmpTrapAddress	The address of the SNMP trap.
F	performanceMonitor ThresholdCrossingAlert (from CERENT-454-mib)	(1)	cerent454NodeTime	The time that an event occurred.
		(2)	cerent454AlarmState	The alarm severity and service-affecting status. Severities are Minor, Major, and Critical. Service-affecting statuses are Service-Affecting and Non-Service Affecting.
		(3)	cerent454AlarmObjectType	The entity that raised the alarm. The NMS should use this value to decide which table to poll for further information about the alarm.
		(4)	cerent454AlarmObjectIndex	Every alarm is raised by an object entry in a specific table. This variable is the index of objects in each table; if the alarm is interface-related, this is the index of the interface in the interface table.
		(5)	cerent454AlarmSlotNumber	The slot of the object that raised the alarm. If a slot is not relevant to the alarm, the slot number is zero.
		(6)	cerent454AlarmPortNumber	The port of the object that raised the alarm. If a port is not relevant to the alarm, the port number is zero.
		(7)	cerent454AlarmLineNumber	The object line that raised the alarm. If a line is not relevant to the alarm, the line number is zero.
		(8)	cerent454AlarmObjectName	The TL1-style user-visible name that uniquely identifies an object in the system.
		(9)	cerent454ThresholdMonitorType	This object indicates the type of metric being monitored.

Table 16-8 ONS 15454 SNMPv2 Trap Variable Bindings (continued)

Group	Trap Name(s) Associated with	Variable Binding Number	SNMPv2 Variable Bindings	Description
F (cont.)		(10)	cerent454ThresholdLocation	Indicates whether the event occurred at the near or far end.
		(11)	cerent454ThresholdPeriod	Indicates the sampling interval period.
		(12)	cerent454ThresholdSetValue	The value of this object is the threshold provisioned by the NMS.
		(13)	cerent454ThresholdCurrentValue	—
		(14)	cerent454ThresholdDetectType	—
		(15)	snmpTrapAddress	The address of the SNMP trap.
G	All other traps (from CERENT-454-MIB) not listed above	(1)	cerent454NodeTime	The time that an event occurred.
		(2)	cerent454AlarmState	The alarm severity and service-affecting status. Severities are Minor, Major, and Critical. Service-affecting statuses are Service-Affecting and Non-Service Affecting.
		(3)	cerent454AlarmObjectType	The entity that raised the alarm. The NMS should use this value to decide which table to poll for further information about the alarm.
		(4)	cerent454AlarmObjectIndex	Every alarm is raised by an object entry in a specific table. This variable is the index of objects in each table; if the alarm is interface-related, this is the index of the interface in the interface table.
		(5)	cerent454AlarmSlotNumber	The slot of the object that raised the alarm. If a slot is not relevant to the alarm, the slot number is zero.
		(6)	cerent454AlarmPortNumber	The port of the object that raised the alarm. If a port is not relevant to the alarm, the port number is zero.
		(7)	cerent454AlarmLineNumber	The object line that raised the alarm. If a line is not relevant to the alarm, the line number is zero.

Table 16-8 ONS 15454 SNMPv2 Trap Variable Bindings (continued)

Group	Trap Name(s) Associated with	Variable Binding Number	SNMPv2 Variable Bindings	Description
G (cont.)		(8)	cerent454AlarmObjectName	The TL1-style user-visible name that uniquely identifies an object in the system.
		(9)	snmpTrapAddress	The address of the SNMP trap.

16.8 SNMP Community Names

Community names are used to group SNMP trap destinations. All ONS 15454 trap destinations can be provisioned as part of SNMP communities in Cisco Transport Controller (CTC). When community names are assigned to traps, the ONS 15454 treats the request as valid if the community name matches one that is provisioned in CTC. In this case, all agent-managed MIB variables are accessible to that request. If the community name does not match the provisioned list, SNMP drops the request.

16.9 Proxy Over Firewalls

SNMP and NMS applications have traditionally been unable to cross firewalls used for isolating security risks inside or from outside networks. Release 7.0 CTC enables network operations centers (NOCs) to access performance monitoring data such as RMON statistics or autonomous messages across firewalls by using an SNMP proxy element installed on a firewall.

The application-level proxy transports SNMP protocol data units (PDU) between the NMS and NEs, allowing requests and responses between the NMS and NEs and forwarding NE autonomous messages to the NMS. The proxy agent requires little provisioning at the NOC and no additional provisioning at the NEs.

The firewall proxy is intended for use in a gateway network element-end network element (GNE-ENE) topology with many NEs through a single NE gateway. Up to 64 SNMP requests (such as get, getnext, or getbulk) are supported at any time behind single or multiple firewalls. The proxy interoperates with common NMS such as HP OpenView.

For security reasons, the SNMP proxy feature must be enabled at all receiving and transmitting NEs to function. For instructions to do this, refer to the *Cisco ONS 15454 Procedure Guide*.

16.10 Remote Monitoring

The ONS 15454 incorporates RMON to allow network operators to monitor Ethernet card performance and events. The RMON thresholds are user-provisionable in CTC. Refer to the *Cisco ONS 15454 Procedure Guide* for instructions. Note that otherwise, RMON operation is invisible to the typical CTC user.

ONS 15454 system RMON is based on the IETF-standard MIB RFC 2819 and includes the following five groups from the standard MIB: Ethernet Statistics, History Control, Ethernet History, Alarm, and Event.

16.10.1 64-Bit RMON Monitoring over DCC

The ONS 15454 DCC is implemented over the IP protocol, which is not compatible with Ethernet. The system builds Ethernet equipment History and Statistics tables using HDLC statistics that are gathered over the DCC (running point-to-point protocol, or PPP). This release adds RMON DCC monitoring (for both IP and Ethernet) to monitor the health of remote DCC connections.

In R7.0, the implementation contains two MIBs for DCC interfaces. They are:

- `cMediaIndependentTable`—standard, `rfc3273`; the proprietary extension of the HC-RMON MIB used for reporting statistics
- `cMediaIndependentHistoryTable`—proprietary MIB used to support history

16.10.1.1 Row Creation in `MediaIndependentTable`

The `SetRequest` PDU for creating a row in the `mediaIndependentTable` should contain all the values required to activate a row in a single set operation along with an assignment of the status variable to `createRequest` (2). The `SetRequest` PDU for entry creation must have all the object IDs (OIDs) carrying an instance value of 0. That is, all the OIDs should be of the type `OID.0`.

In order to create a row, the `SetRequest` PDU should contain the following:

- `mediaIndependentDataSource` and its desired value
- `mediaIndependentOwner` and its desired value (The size of `mediaIndependentOwner` is limited to 32 characters.)
- `mediaIndependentStatus` with a value of `createRequest` (2)

The `mediaIndependentTable` creates a row if the `SetRequest` PDU is valid according to the above rules. When the row is created, the SNMP agent decides the value of `mediaIndependentIndex`. This value is not sequentially allotted or contiguously numbered. It changes when an Ethernet interface is added or deleted. The newly created row will have `mediaIndependentTable` value of `valid` (1).

If the row already exists, or if the `SetRequest` PDU values are insufficient or do not make sense, the SNMP agent returns an error code.

**Note**

`mediaIndependentTable` entries are not preserved if the SNMP agent is restarted.

The `mediaIndependentTable` deletes a row if the `SetRequest` PDU contains a `mediaIndependentStatus` with a value of `invalid` (4). The `varbind`'s OID instance value identifies the row for deletion. You can recreate a deleted row in the table if desired.

16.10.1.2 Row Creation in `cMediaIndependentHistoryControlTable`

SNMP row creation and deletion for the `cMediaIndependentHistoryControlTable` follows the same processes as for the `MediaIndependentTable`; only the variables differ.

In order to create a row, the `SetRequest` PDU should contain the following:

- `cMediaIndependentHistoryControlDataSource` and its desired value
- `cMediaIndependentHistoryControlOwner` and its desired value
- `cMediaIndependentHistoryControlStatus` with a value of `createRequest` (2)

16.10.2 HC-RMON-MIB Support

For the ONS 15454, the implementation of the high-capacity remote monitoring information base (HC-RMON-MIB, or RFC 3273) enables 64-bit support of existing RMON tables. This support is provided with the `etherStatsHighCapacityTable` and the `etherHistoryHighCapacityTable`. An additional table, the `mediaIndependentTable`, and an additional object, `hcRMONCapabilities`, are also added for this support. All of these elements are accessible by any third-party SNMP client having RFC 3273 support.

16.10.3 Ethernet Statistics RMON Group

The Ethernet Statistics group contains the basic statistics monitored for each subnetwork in a single table called the `etherStatsTable`.

16.10.3.1 Row Creation in `etherStatsTable`

The `SetRequest` PDU for creating a row in this table should contain all the values needed to activate a row in a single set operation, and an assigned status variable to `createRequest`. The `SetRequest` PDU object ID (OID) entries must all carry an instance value, or type OID, of 0.

In order to create a row, the `SetRequest` PDU should contain the following:

- The `etherStatsDataSource` and its desired value
- The `etherStatsOwner` and its desired value (size of this value is limited to 32 characters)
- The `etherStatsStatus` with a value of `createRequest` (2)

The `etherStatsTable` creates a row if the `SetRequest` PDU is valid according to the above rules. When the row is created, the SNMP agent decides the value of `etherStatsIndex`. This value is not sequentially allotted or contiguously numbered. It changes when an Ethernet interface is added or deleted. The newly created row will have `etherStatsStatus` value of `valid` (1).

If the `etherStatsTable` row already exists, or if the `SetRequest` PDU values are insufficient or do not make sense, the SNMP agent returns an error code.



Note

`etherStatsTable` entries are not preserved if the SNMP agent is restarted.

16.10.3.2 Get Requests and `GetNext` Requests

`Get` requests and `getNext` requests for the `etherStatsMulticastPkts` and `etherStatsBroadcastPkts` columns return a value of zero because the variables are not supported by ONS 15454 Ethernet cards.

16.10.3.3 Row Deletion in `etherStatsTable`

To delete a row in the `etherStatsTable`, the `SetRequest` PDU should contain an `etherStatsStatus` “invalid” value (4). The OID marks the row for deletion. If required, a deleted row can be recreated.

16.10.3.4 64-Bit etherStatsHighCapacity Table

The Ethernet statistics group contains 64-bit statistics in the etherStatsHighCapacityTable, which provides 64-bit RMON support for the HC-RMON-MIB. The etherStatsHighCapacityTable is an extension of the etherStatsTable that adds 16 new columns for performance monitoring data in 64-bit format. There is a one-to-one relationship between the etherStatsTable and etherStatsHighCapacityTable when rows are created or deleted in either table.

16.10.4 History Control RMON Group

The History Control group defines sampling functions for one or more monitor interfaces in the historyControlTable. The values in this table, as specified in RFC 2819, are derived from the historyControlTable and etherHistoryTable.

16.10.4.1 History Control Table

The RMON is sampled at one of four possible intervals. Each interval, or period, contains specific history values (also called buckets). [Table 16-9](#) lists the four sampling periods and corresponding buckets.

The historyControlTable maximum row size is determined by multiplying the number of ports on a card by the number of sampling periods. For example, an ONS 15454 E100 card contains 24 ports, which multiplied by periods allows 96 rows in the table. An E1000 card contains 14 ports, which multiplied by four periods allows 56 table rows.

Table 16-9 RMON History Control Periods and History Categories

Sampling Periods (historyControlValue Variable)	Total Values, or Buckets (historyControl Variable)
15 minutes	32
24 hours	7
1 minute	60
60 minutes	24

16.10.4.2 Row Creation in historyControlTable

The SetRequest PDU must be able to activate a historyControlTable row in one single-set operation. In order to do this, the PDU must contain all needed values and have a status variable value of 2 (createRequest). All OIDs in the SetRequest PDU should be type OID.0 type for entry creation.

To create a SetRequest PDU for the historyControlTable, the following values are required:

- The historyControlDataSource and its desired value
- The historyControlBucketsRequested and its desired value
- The historyControlInterval and its desired value
- The historyControlOwner and its desired value
- The historyControlStatus with a value of createRequest (2)

The `historyControlBucketsRequested` OID value is ignored because the number of buckets allowed for each sampling period, based upon the `historyControlInterval` value, is already fixed as listed in [Table 16-9](#).

The `historyControlInterval` value cannot be changed from the four allowed choices. If you use another value, the SNMP agent selects the closest smaller time period from the set buckets. For example, if the set request specifies a 25-minute interval, this falls between the 15-minute (32 bucket) variable and the 60-minute (24 bucket) variable. The SNMP agent automatically selects the lower, closer value, which is 15 minutes, so it allows 32 buckets.

If the `SetRequest` PDU is valid, a `historyControlTable` row is created. If the row already exists, or if the `SetRequest` PDU values do not make sense or are insufficient, the SNMP agent does not create the row and returns an error code.

16.10.4.3 Get Requests and GetNext Requests

These PDUs are not restricted.

16.10.4.4 Row Deletion in historyControl Table

To delete a row from the table, the `SetRequest` PDU should contain a `historyControlStatus` value of 4 (invalid). A deleted row can be recreated.

16.10.5 Ethernet History RMON Group

The ONS 15454 implements the `etherHistoryTable` as defined in RFC 2819. The group is created within the bounds of the `historyControlTable` and does not deviate from the RFC in its design.

16.10.5.1 64-Bit etherHistoryHighCapacityTable

64-bit Ethernet history for the HC-RMON-MIB is implemented in the `etherHistoryHighCapacityTable`, which is an extension of the `etherHistoryTable`. The `etherHistoryHighCapacityTable` adds four columns for 64-bit performance monitoring data. These two tables have a one-to-one relationship. Adding or deleting a row in one table will effect the same change in the other.

16.10.6 Alarm RMON Group

The Alarm group consists of the `alarmTable`, which periodically compares sampled values with configured thresholds and raises an event if a threshold is crossed. This group requires the implementation of the event group, which follows this section.

16.10.6.1 Alarm Table

The NMS uses the `alarmTable` to determine and provision network performance alarmable thresholds.

16.10.6.2 Row Creation in alarmTable

To create a row in the alarmTable, the SetRequest PDU must be able to create the row in one single-set operation. All OIDs in the SetRequest PDU should be type OID.0 type for entry creation. The table has a maximum number of 256 rows.

To create a SetRequest PDU for the alarmTable, the following values are required:

- The alarmInterval and its desired value
- The alarmVariable and its desired value
- The alarmSampleType and its desired value
- The alarmStartupAlarm and its desired value
- The alarmOwner and its desired value
- The alarmStatus with a value of createRequest (2)

If the SetRequest PDU is valid, a historyControlTable row is created. If the row already exists, or if the SetRequest PDU values do not make sense or are insufficient, the SNMP agent does not create the row and returns an error code.

In addition to the required values, the following restrictions must be met in the SetRequest PDU:

- The alarmOwner is a string of length 32 characters.
- The alarmRisingEventIndex always takes value 1.
- The alarmFallingEventIndex always takes value 2.
- The alarmStatus has only two values supported in SETs: createRequest (2) and invalid (4).
- The AlarmVariable is of the type OID.ifIndex, where ifIndex gives the interface this alarm is created on and OID is one of the OIDs supported in [Table 16-10](#).

Table 16-10 OIDs Supported in the AlarmTable

No.	Column Name	OID	Status
1	ifInOctets	{1.3.6.1.2.1.2.2.1.10}	—
2	IfInUcastPkts	{1.3.6.1.2.1.2.2.1.11}	—
3	ifInMulticastPkts	{1.3.6.1.2.1.31.1.1.1.2}	Unsupported in E100/E1000
4	ifInBroadcastPkts	{1.3.6.1.2.1.31.1.1.1.3}	Unsupported in E100/E1000
5	ifInDiscards	{1.3.6.1.2.1.2.2.1.13}	Unsupported in E100/E1000
6	ifInErrors	{1.3.6.1.2.1.2.2.1.14}	—
7	ifOutOctets	{1.3.6.1.2.1.2.2.1.16}	—
8	ifOutUcastPkts	{1.3.6.1.2.1.2.2.1.17}	—
9	ifOutMulticastPkts	{1.3.6.1.2.1.31.1.1.1.4}	Unsupported in E100/E1000
10	ifOutBroadcastPkts	{1.3.6.1.2.1.31.1.1.1.5}	Unsupported in E100/E1000
11	ifOutDiscards	{1.3.6.1.2.1.2.2.1.19}	Unsupported in E100/E1000
12	Dot3StatsAlignmentErrors	{1.3.6.1.2.1.10.7.2.1.2}	—
13	Dot3StatsFCSErrors	{1.3.6.1.2.1.10.7.2.1.3}	—
14	Dot3StatsSingleCollisionFrames	{1.3.6.1.2.1.10.7.2.1.4}	—
15	Dot3StatsMultipleCollisionFrames	{1.3.6.1.2.1.10.7.2.1.5}	—

Table 16-10 *OIDs Supported in the AlarmTable (continued)*

No.	Column Name	OID	Status
16	Dot3StatsDeferredTransmissions	{1.3.6.1.2.1.10.7.2.1.7}	—
17	Dot3StatsLateCollisions	{1.3.6.1.2.1.10.7.2.1.8}	—
18	Dot3StatsExcessiveCollisions	{1.3.6.1.2.1.10.7.2.1.9}	—
19	Dot3StatsFrameTooLong	{1.3.6.1.2.1.10.7.2.1.13}	—
20	Dot3StatsCarrierSenseErrors	{1.3.6.1.2.1.10.7.2.1.11}	Unsupported in E100/E1000
21	Dot3StatsSQETestErrors	{1.3.6.1.2.1.10.7.2.1.6}	Unsupported in E100/E1000
22	etherStatsUndersizePkts	{1.3.6.1.2.1.16.1.1.1.9}	—
23	etherStatsFragments	{1.3.6.1.2.1.16.1.1.1.11}	—
24	etherStatsPkts64Octets	{1.3.6.1.2.1.16.1.1.1.14}	—
25	etherStatsPkts65to127Octets	{1.3.6.1.2.1.16.1.1.1.15}	—
26	etherStatsPkts128to255Octets	{1.3.6.1.2.1.16.1.1.1.16}	—
27	etherStatsPkts256to511Octets	{1.3.6.1.2.1.16.1.1.1.17}	—
28	etherStatsPkts512to1023Octets	{1.3.6.1.2.1.16.1.1.1.18}	—
29	etherStatsPkts1024to1518Octets	{1.3.6.1.2.1.16.1.1.1.19}	—
30	EtherStatsBroadcastPkts	{1.3.6.1.2.1.16.1.1.1.6}	—
31	EtherStatsMulticastPkts	{1.3.6.1.2.1.16.1.1.1.7}	—
32	EtherStatsOversizePkts	{1.3.6.1.2.1.16.1.1.1.10}	—
33	EtherStatsJabbers	{1.3.6.1.2.1.16.1.1.1.12}	—
34	EtherStatsOctets	{1.3.6.1.2.1.16.1.1.1.4}	—
35	EtherStatsCollisions	{1.3.6.1.2.1.16.1.1.1.13}	—
36	EtherStatsCollisions	{1.3.6.1.2.1.16.1.1.1.8}	—
37	EtherStatsDropEvents	{1.3.6.1.2.1.16.1.1.1.3}	Unsupported in E100/E1000 and G1000

16.10.6.3 Get Requests and GetNext Requests

These PDUs are not restricted.

16.10.6.4 Row Deletion in alarmTable

To delete a row from the table, the SetRequest PDU should contain an alarmStatus value of 4 (invalid). A deleted row can be recreated. Entries in this table are preserved if the SNMP agent is restarted.

16.10.7 Event RMON Group

The Event group controls event generation and notification. It consists of two tables: the eventTable, which is a read-only list of events to be generated, and the logTable, which is a writable set of data describing a logged event. The ONS 15454 implements the logTable as specified in RFC 2819.

16.10.7.1 Event Table

The eventTable is read-only and unprovisionable. The table contains one row for rising alarms and another for falling ones. This table has the following restrictions:

- The eventType is always log-and-trap (4).
- The eventCommunity value is always a zero-length string, indicating that this event causes the trap to be despatched to all provisioned destinations.
- The eventOwner column value is always “monitor.”
- The eventStatus column value is always valid(1).

16.10.7.2 Log Table

The logTable is implemented exactly as specified in RFC 2819. The logTable is based upon data that is locally cached in a controller card. If there is a controller card protection switch, the existing logTable is cleared and a new one is started on the newly active controller card. The table contains as many rows as provided by the alarm controller.



APPENDIX **A**

Hardware Specifications



Note

The terms "Unidirectional Path Switched Ring" and "UPSR" may appear in Cisco literature. These terms do not refer to using Cisco ONS 15xxx products in a unidirectional path switched ring configuration. Rather, these terms, as well as "Path Protected Mesh Network" and "PPMN," refer generally to Cisco's path protection feature, which may be used in any topological network configuration. Cisco does not recommend using its path protection feature in any particular topological network configuration.

This appendix contains hardware and software specifications for the ONS 15454.

A.1 Shelf Specifications

This section provides specifications for shelf bandwidth; a list of topologies; Cisco Transport Controller (CTC) specifications; LAN, TL1, modem, alarm, and electrical interface assembly (EIA) interface specifications; timing, power, and environmental specifications; and shelf dimensions.

A.1.1 Bandwidth

The ONS 15454 has the following bandwidth specifications:

- Total bandwidth: 240 Gbps
- Data plane bandwidth: 160 Gbps
- SONET plane bandwidth: 80 Gbps

A.1.2 Configurations

The ONS 15454 can be configured as follows:

- Two-fiber path protection
- Path protected mesh network (PPMN)
- Two-fiber bidirectional line switch ring (BLSR)
- Four-fiber BLSR
- Add-drop multiplexer (ADM)
- Terminal mode

- Regenerator mode
- Hubbed rings
- Multihubbed rings
- Point-to-point
- Linear
- Linear with optical add/drop multiplexing (OADM)

A.1.3 Cisco Transport Controller

CTC, the ONS 15454 craft interface software, has the following specifications:

- 10BaseT
- TCC2/TCC2P access: RJ-45 connector
- Backplane access: LAN pin field

A.1.4 External LAN Interface

The ONS 15454 external LAN interface has the following specifications:

- 10BaseT Ethernet
- Backplane access: LAN pin field

A.1.5 TL1 Craft Interface

The ONS 15454 TL1 craft interface has the following specifications:

- Speed: 9600 bps
- TCC2/TCC2P access: EIA/TIA-232 DB-9 type connector
- Backplane access: CRAFT pin field

A.1.6 Modem Interface

The ONS 15454 modem interface has the following specifications:

- Hardware flow control
- TCC2/TCC2P: EIA/TIA-232 DB-9 type connector

A.1.7 Alarm Interface

The ONS 15454 alarm interface has the following specifications:

- Visual: Critical, Major, Minor, Remote
- Audible: Critical, Major, Minor, Remote
- Alarm contacts: 0.045 mm, -48 V, 50 mA

- Backplane access: Alarm pin fields

A.1.8 EIA Interface

The ONS 15454 EIA interface has the following specifications:

- SMB: AMP #415504-3 75-ohm, 4-leg connectors
- BNC: Trompeter #UCBJ224 75-ohm 4 leg connector (King and ITT are also compatible)
- AMP Champ: AMP#552246-1 with #552562-2 bail locks

A.1.9 BITS Interface

The ONS 15454 building integrated timing supply (BITS) interface has the following specifications:

- 2 DS-1 BITS inputs
- 2 derived DS-1 outputs
- Backplane access: BITS pin field

A.1.10 System Timing

The ONS 15454 has the following system timing specifications:

- Stratum 3 per Telcordia GR-253-CORE
- Free running accuracy: ± 4.6 ppm
- Holdover stability: 3.7×10^{-7} per day, including temperature (< 255 slips in first 24 hours)
- Reference: External BITS, line, internal

A.1.11 System Power

The ONS 15454 has the following power specifications:

- Input power: -48 VDC
- Power consumption: Configuration dependent; 72 W (fan tray only)
- Power requirements: -40.5 to -57 VDC
- Power terminals: #8-32 screw. Ring or fork type lug suitable for 10 AWG stranded conductor with a 0.375inch maximum width.
- ANSI shelf: Two 30 A fuses (customer supplied fuse and alarm panel)
- HD shelf: 30 A fuse per shelf (customer supplied fuse and alarm panel)

A.1.12 System Environmental Specifications

The ONS 15454 has the following environmental specifications:

- Operating temperature: 0 to +55 degrees Celsius; -40 to +65 degrees Celsius with industrial temperature rated cards

- Operating humidity: 5 to 95 percent, noncondensing

A.1.13 Dimensions

The ONS 15454 shelf assembly has the following dimensions:

- Height: 18.5 in. (40.7 cm)
- Width: 19 or 23 in. (41.8 or 50.6 cm) with mounting ears attached
- Depth: 12 in. (26.4 cm) (5 in. or 12.7 cm projection from rack)
- Weight: 55 lb (24.947 kg) empty

A.2 SFP, XFP, and GBIC Specifications

Table A-1 lists the specifications for the available Small Form-factor Pluggables (SFPs), 10 Gbps Pluggables (XFPs) and GBICs. In the table, the following acronyms are used:

- ESCON = Enterprise System Connection
- FICON = fiber connectivity
- GE = Gigabit Ethernet
- FC = Fibre Channel
- HDTV = high definition television
- CWDM = coarse wavelength division multiplexing

Table A-1 SFP, XFP, and GBIC Specifications

SFP/XFP Product ID	Interface	Transmitter Output Power Min/Max (dBm)	Receiver Input Power Min/Max (dBm)
15454-SFP-LC-SX/ 15454E-SFP-LC-SX	GE	-9.5 to -4	-17 to 0
15454-SFP-LC-LX/ 15454E-SFP-LC-LX	GE	-9.5 to -3	-19 to -3
15454-SFP3-1-IR=	OC-3	-15 to -8	-23 to -8
15454E-SFP-L.1.1=	STM-1	-15 to -8	-34 to -10
15454-SFP12-4-IR=	OC-12, D1 Video	-15 to -8	-28 to -7
15454E-SFP-L.4.1=	STM-4, D1 Video	-15 to -8	-28 to -8
15454-SFP-OC48-IR=	OC-48, DV6000 (C-Cor)	-5 to +0	-18 to +0
ONS-SE-2G-S1=	OC-48, STM-16	-10 to -3	-18 to -3
15454E-SFP-L.16.1=	STM-16, DV6000 (C-Cor)	-5 to +0	-18 to +0
15454-SFP-200/ 15454E-SFP-200	ESCON	-8 to -4	-28 to -3
15454-SFP-GEFC-SX=/ 15454E-SFP-GEFC-S=	FC (1 and 2 Gbps), FICON, GE	-10 to -3.5	-17 to 0 (1 FC and 1GE) -15 to 0 (2 FC)

Table A-1 SFP, XFP, and GBIC Specifications (continued)

SFP/XFP Product ID	Interface	Transmitter Output Power Min/Max (dBm)	Receiver Input Power Min/Max (dBm)
15454-SFP-GE+-LX= 15454E-SFP-GE+-LX=	FC (1 and 2 Gbps), FICON, GE, HDTV	-9.5 to -3	-20 to -3 (1 FC, 1GE, and 2 FC)
ONS-SE-200-MM=	ESCON	-20.5 to -15	-14 to -29 ¹
ONS-SE-G2F-SX=	Fibre Channel (1 and 2 Gbps), GE	-9.5 to 0 (GE) -10 to -3.5 (1G and 2G FC/FICON)	-17 to 0 ² (GE) -22 (1G FC/FICON) -20 (2G FC/FICON)
ONS-SE-G2F-LX=	Fibre Channel (1 and 2 Gbps), FICON, GE, HDTV	-9.5 to -3 (GE) -10 to -3.5 (1FC, 2FC, and FICON)	-19 to -3 ³ (GE) -22 (1G FC/FICON) -21 (2G FC/FICON)
ONS-SC-GE-SX=	GE	-9.5 to 0	-17 to 0 ²
ONS-SC-GE-LX=	GE	-9.5 to -3	-19 to -3 ³
ONS-SI-2G-S1	OC-48 SR	-10 to -3	-18 to -3
ONS-SI-2G-I1	OC-48 IR1	-5 to 0	-18 to 0
ONS-SI-2G-L1	OC-48 LR1	-2 to 3	-27 to -9
ONS-SI-2G-L2	OC-48 LR2	-2 to 3	-28 to -9
ONS-SC-2G-30.3 through ONS-SC-2G-60.6	OC-48 DWDM	0 to 4	-28 to -9
ONS-SI-622-I1	OC-3/OC-12 IR1 Dual rate	-15 to -8	-28 to -8
ONS-SI-622-L1	OC-12 LR1	-3 to 2	-28 to -8
ONS-SI-622-L2	OC-12 LR2	-3 to 2	-28 to -8
ONS-SE-622-1470 through ONS-SE-622-1610	OC-12 CWDM	0 to 5	-28 to -7
ONS-SI-155-I1	OC-3 IR1	-15 to -8	-28 to -8
ONS-SI-155-L1	OC-3 LR1	-5 to 0	-34 to -10
ONS-SI-155-L2	OC-3 LR2	-5 to 0	-34 to -10
ONS-SE-155-1470 through ONS-SE-155-1610	OC-3 CWDM	0 to 5	-34 to -7
ONS-XC-10G-S1	OC-192 SR1	-6 to -1	-11 to -1
ONS-XC-10G-I2	OC-192 IR2	-1 to +2	-14 to +2
ONS-XC-10G-L2	OC-192 LR2	0 to 4	-24 to -7
ONS-SE-100-FX	Fast Ethernet	-20 to -14	-30 to -14
ONS-SE-100-LX10	Fast Ethernet	-15 to -8	-25 to -8
15454-GBIC-SX	FC, GE	-9.5 to -3.5	-19 to -3
15454E-GBIC-SX	GE, FC		
15454-GBIC-LX/LH	GE, FC	-9 to -3	-19 to -3

Table A-1 SFP, XFP, and GBIC Specifications (continued)

SFP/XFP Product ID	Interface	Transmitter Output Power Min/Max (dBm)	Receiver Input Power Min/Max (dBm)
15454E-GBIC-LX/LH	GE, FC	-9 to -3	-19 to -3
ONS-GX-2FC-MMI	FC	-9.5 to -5	-20.5/-15 max
ONS-GX-2FC-SML	FC	-9 to -3	-18 to -3

1. Based on any valid 8B/10B code pattern measured at, or extrapolated to, 10E-15 BER measured at center of eye
2. Minimum Stressed Sensitivity (10-12): -12.5(62.5um) and -13.5(50um) dBm
3. Minimum Stressed Sensitivity (10⁻¹²): -14.4 dBm

A.3 General Card Specifications

This section provides power specifications and temperature ranges for all ONS 15454 cards.

A.3.1 Power

[Table A-2](#) provides power consumption information for the ONS 15454 cards.

Table A-2 Individual Card Power Requirements

Card Type	Card Name	Watts	Amperes	BTU/Hr.
Control Cards	TCC2	19.20	0.4	66.8
	TCC2P	27.00	0.56	92.2
	XCVT	34.40	0.72	117.46
	XC10G	48	1	163.68
	XC-VXC-10G	67	1.4	228.62
	AIC-I	4.8	0.1	15.3
	AEP	3	(from +5 VDC from AIC-I)	10.2

Table A-2 Individual Card Power Requirements (continued)

Card Type	Card Name	Watts	Amperes	BTU/Hr.
Electrical Cards	EC1-12	36.60	0.76	124.97
	DS1-14	12.60	0.26	43.02
	DS1N-14	12.60	0.26	43.02
	DS1/E1-56	36.00	0.76	124.97
	DS3-12	38.20	0.79	130.43
	DS3/EC1-48	30	0.58	95.6
	DS3N-12	38.20	0.79	130.43
	DS3i-N-12	30	0.63	102.4
	DS3-12E	26.80	0.56	91.51
	DS3N-12E	26.80	0.56	91.51
	DS3XM-12 Transmux	34	0.71	116.1
	DS3XM-6 Transmux	20	0.42	68
Optical Cards	OC3 IR 4	19.20	0.40	65.56
	OC3 IR 4/STM1 SH 1310	19.20	0.40	65.56
	OC3 IR 4/STM1SH 1310-8	26.00	0.48	78.5
	OC12 IR 1310	10.90	0.23	37.22
	OC12 LR 1310	9.28	0.2	31.68
	OC12 LR 1550	9.28	0.2	31.68
	OC12 LR/STM4 LH 1310	9.00	0.2	31.68
	OC12 LR/STM4 LH 1550	9.28	0.2	31.68
	OC12 IR/STM4 SH 1310-4	35.60	0.74	121.6
	OC48 IR 1310	32.20	0.67	109.94
	OC48 LR 1550	26.80	0.56	91.50
	OC48 IR/STM16 SH AS 1310	37.20	0.77	127.01
	OC48 LR/STM16 LH AS 1550	37.20	0.77	127.01
	OC48 ELR/STM16 EH 100 GHz	31.20	0.65	106.53
	OC48 ELR 200 GHz	31.20	0.65	106.53
Optical Cards	OC192 SR/STM64 IO H 1310	41.80	0.90	132.00
	OC192 IR/STM64 SH 1550	48.00	1.00	163.68
	OC192 LR/STM64 LH 1550	41.80	0.90	132.00
	OC192 LR/STM64 LH 15xx.xx	62.40	1.30	214.00
	15454_MRC-12	38	0.79	129.66
	OC192SR1/STM64IO Short Reach and OC-192/STM64 Any Reach ¹	40	0.83	136.49

Table A-2 Individual Card Power Requirements (continued)

Card Type	Card Name	Watts	Amperes	BTU/Hr.
Ethernet Cards	E100T-12	65	1.35	221.93
	E100T-G	65	1.35	221.93
	E1000-2	53.50	1.11	182.67
	E1000-2-G	53.50	1.11	182.67
	G1K-4	63.00 (including GBICs ²)	1.31	215.11
	ML100T-12	53	1.10	181.0
	ML1000-2	49 (including SFPs)	1.02	167.3
	ML100X-8	65	1.35	221.93
	CE-100T-8	53.14	1.10	181.3
	CE-1000-4	60	1.25	204.80
Storage Access Networking	FC_MR-4	60	1.25	212.00

1. These cards are designated as OC192-XFP in CTC.

2. GBICs = Gigabit Interface Converters

A.3.2 Temperature

Table A-3 provides temperature ranges and product names for ONS 15454 cards.



Note

The I-Temp symbol is displayed on the faceplate of an I-Temp compliant card. A card without this symbol is C-Temp compliant.

Table A-3 Card Temperature Ranges and Product Names

Card Type	Card Name	C-Temp Product Name (32 to 131 degrees Fahrenheit, 0 to +55 degrees Celsius)	I-Temp Product Name (-40 to 149 degrees Fahrenheit, -40 to +65 degrees Celsius)
Control Cards	TCC2	—	15454-TCC2
	TCC2P	—	15454-TCC2P
	XCVT	15454-XC-VT	15454-XC-VT-T
	XC10G	15454-XC-10G	—
	XC-VXC-10G	—	15454-XC-VXC-10G-T
	AIC-I	—	15454-AIC-I
	AEP	—	15454-AEP

Table A-3 Card Temperature Ranges and Product Names (continued)

Card Type	Card Name	C-Temp Product Name (32 to 131 degrees Fahrenheit, 0 to +55 degrees Celsius)	I-Temp Product Name (-40 to 149 degrees Fahrenheit, -40 to +65 degrees Celsius)
Electrical	EC1-12	15454-EC1-12	15454-EC1-12-T
	DS1-14	15454-DS1-14	15454-DS1-14-T
	DS1N-14	15454-DS1N-14	15454-DS1N-14-T
	DS1/E1-56	—	15454-DS1E1-56
	DS3-12	15454-DS3-12	15454-DS3-12-T
	DS3/EC1-48	—	15454-DS3_EC1-48
	DS3N-12	15454-DS3N-12	15454-DS3N-12-T
	DS3i-N-12	15454-DS3i-N-12	—
	DS3-12E	—	15454-DS3-12E-T
	DS3N-12E	—	15454-DS3N-12E-T
	DS3XM-12 (Transmux)	—	15454-DS3XM-12
	DS3XM-6 (Transmux)	15454-DS3XM-6	15454-DS3XM-6-T
	Optical	OC3 IR 4/STM1 SH 1310	15454-OC34IR1310
OC3 IR/STM1 SH 1310-8		15454-OC3I8-1310	—
OC12 IR/STM4 SH 1310		15454-OC12IIR1310	15454-OC12I13-T
OC12 LR/STM4 LH 1310		15454-OC12ILR1310	15454-OC12IL13-T
OC12 LR/STM4 LH 1550		15454-OC12ILR1550	15454-OC12IL15-T
OC12 IR/STM4 SH 1310-4		15454-OC12I4-1310	—
OC48 IR 1310		15454-OC48IIR1310	—
OC48 LR 1550		15454-OC48ILR1550	—
OC48 IR/STM16 SH AS 1310		15454-OC48IIR1310A	—
OC48 LR/STM16 LH AS 1550		15454-OC48ILR1550A	—
OC48 ELR/STM16 EH 100 GHz		15454-OC48E-1-xx.xx (all wavelengths)	—
OC48 ELR/STM16 EH 200 GHz		15454-OC48E-xx.xx (all wavelengths)	—

Table A-3 Card Temperature Ranges and Product Names (continued)

Card Type	Card Name	C-Temp Product Name (32 to 131 degrees Fahrenheit, 0 to +55 degrees Celsius)	I-Temp Product Name (-40 to 149 degrees Fahrenheit, -40 to +65 degrees Celsius)
Optical	OC 192 SR/STM64 IO 1310	15454-OC192IO1310	—
	OC192 IR/STM64 SH 1550	15454-OC192IR1550	—
	OC192 LR/STM64 LH 1550	15454-OC192LR1550	—
	OC192 LR/STM64 LH ITU 15xx.xx	15454-OC192LR15xx	—
	15454_MRC-12	—	15454-MRC-12-T
	OC-192/STM-64 SR1 Short Reach ¹	15454_OC-192/STM-64 SR1 Short Reach	—
	OC-192/STM-64 Any Reach ¹	15454_OC-192/STM-64 Any Reach	—
Ethernet	E100T-12	15454-E100T	—
	E100T-G	15454-E100T-G	—
	E1000-2	15454-E1000-2	—
	E1000-2-G	15454-E1000-2-G	—
	G1K-4	15454-G1K-4	—
	ML100T-12	15454-ML100T-12	—
	ML1000-2	15454-ML1000-2	—
	ML100X-8	—	15454-ML100X-8
	CE-100T-8	15454-CE100T-8	—
	CE-1000-4	15454-CE1000-4	—
Storage Access Networking	FC_MR-4	15454-FC_MR-4	—

1. Designated as OC192-XFP in CTC.

A.4 Common Control Card Specifications

This section provides specifications for the TCC2, TCC2P, XCVT, XC10G, XC-VXC-10G, and AIC-I cards.

For compliance information, refer to the *Cisco Optical Transport Products Safety and Compliance Information* document.

A.4.1 TCC2 Card Specifications

The TCC2 card has the following specifications:

- CTC software

- Interface: EIA/TIA-232 (local craft access, on TCC2 faceplate)
- Interface: 10BaseT LAN (on TCC2 faceplate)
- Interface: 10BaseT LAN (through the backplane)
- Synchronization
 - Stratum 3, per Telcordia GR-253-CORE
 - Free running access: Accuracy +/- 4.6 ppm
 - Holdover stability: $3.7 * 10 \text{ exp} - 7$ per day including temperature (< 255 slips in first 24 hours)
 - Reference: External BITS, line, internal
- Supply voltage monitoring
 - Both supply voltage inputs are monitored.
 - Normal operation: -40.5 to -56.7 V
 - Undervoltage: Major alarm
 - Overvoltage: Major alarm
- Environmental
 - Operating temperature: -40 to +149 degrees Fahrenheit (-40 to +65 degrees Celsius)
 - Operating humidity: 5 to 95 percent, noncondensing
 - Power consumption: 26.00 W, 0.54 A at -48 V, 88.8 BTU/hr
- Dimensions
 - Height: 12.650 in. (321.3 mm)
 - Width: 0.716 in. (18.2 mm)
 - Depth: 9.000 in. (228.6 mm)
 - Depth with backplane connector: 9.250 in. (235 mm)
 - Weight not including clam shell: 1.5 lb (0.7 kg)

A.4.2 TCC2P Card Specifications

The TCC2P card has the following specifications:

- CTC software
 - Interface: EIA/TIA-232 (local craft access, on TCC2P faceplate)
 - Interface: 10BaseT LAN (on TCC2P faceplate)
 - Interface: 10BaseT LAN (via backplane)
- Synchronization
 - Stratum 3, per Telcordia GR-253-CORE
 - Free running access: Accuracy +/- 4.6 ppm
 - Holdover stability: $3.7 * 10 \text{ exp} - 7$ per day including temperature (< 255 slips in first 24 hours)
 - Reference: External BITS, line, internal
- Supply voltage monitoring
 - Both supply voltage inputs are monitored.

- Normal operation: -40.5 to -56.7 V (in -48 VDC systems)
- Undervoltage: Major alarm
- Overvoltage: Major alarm
- Environmental
 - Operating temperature: -40 to +149 degrees Fahrenheit (-40 to +65 degrees Celsius)
 - Operating humidity: 5 to 95 percent, noncondensing
 - Power consumption: 26.00 W, 0.54 A at -48 V, 88.8 BTU/hr
- Dimensions
 - Height: 12.650 in. (321.3 mm)
 - Width: 0.716 in. (18.2 mm)
 - Depth: 9.000 in. (228.6 mm)
 - Depth with backplane connector: 9.250 in. (235 mm)
 - Weight not including clam shell: 1.5 lb (0.7 kg)

A.4.3 XCVT Card Specifications

The XCVT card has the following specifications:

- Environmental
 - Operating temperature:
 - C-Temp (15454-XC-VT): 32 to 131 degrees Fahrenheit (0 to +55 degrees Celsius)
 - I-Temp (15454-XC-VT-T): -40 to 149 degrees Fahrenheit (-40 to +65 degrees Celsius)
 - Operating humidity: 5 to 95 percent, noncondensing
 - Power consumption: 34.40 W, 0.72 A, 117.46 BTU/hr
- Dimensions
 - Height: 12.650 in. (321.3 mm)
 - Width: 0.716 in. (18.2 mm)
 - Depth: 9.000 in. (228.6 mm)
 - Card weight: 1.9 lb (0.8 kg)

A.4.4 XC10G Card Specifications

The XC10G card has the following specifications:

- Environmental
 - Operating temperature:
 - C-Temp (15454-XC-10G): 32 to 131 degrees Fahrenheit (0 to +55 degrees Celsius)
 - Operating humidity: 5 to 85 percent, noncondensing
 - Power consumption: 48 W, 1.00 A, 163.68 BTU/hr
- Dimensions

- Height: 12.650 in. (321.3 mm)
- Width: 0.716 in. (18.2 mm)
- Depth: 9.000 in. (228.6 mm)
- Card weight: 1.5 lb (0.6 kg)

A.4.5 XC-XVC-10G Card Specifications

The XC-XVC-10G card has the following specifications:

- Environmental
 - Operating temperature:
 - I-Temp (15454-XC-VXC-10G-T): -40 to 149 degrees Fahrenheit (-40 to +65 degrees Celsius)
 - Operating humidity: 5 to 85 percent, noncondensing
 - Power consumption: 60 W, 1.25 A, 204.73 BTU/hr
- Dimensions
 - Height: 12.650 in. (321.3 mm)
 - Width: 0.716 in. (18.2 mm)
 - Depth: 9.000 in. (228.6 mm)
 - Card weight: 1.5 lb (0.6 kg)

A.4.6 AIC-I Card Specifications

The AIC-I card has the following specifications:

- Alarm inputs
 - Number of inputs: 12 without alarm extension panel (AEP), 32 with AEP
 - Opto coupler isolated
 - Label is customer provisionable.
 - Severity is customer provisionable.
 - Common 32 V output for all alarm inputs
 - Each input limited to 2 mA
 - Termination: Wire-wrap on backplane without AEP, on AEP connectors with AEP
- Alarm outputs
 - Number of outputs: 4 (user configurable as inputs) without AEP, 16 with AEP
 - Switched by opto MOS (metal oxide semiconductor)
 - Triggered by definable alarm condition
 - Maximum allowed open circuit voltage: 60 VDC
 - Maximum allowed closed circuit current: 100 mA
 - Termination: Wire-wrap on backplane without AEP, on AEP connectors with AEP
- Express orderwire/Local orderwire (EOW/LOW)

- ITU-T G.711, ITU-T G.712, Telcordia GR-253-CORE
- A-law, mu-law



Note Due to the nature of mixed coding, in a mixed-mode configuration (A-law/mu-law) the orderwire is not ITU-T G.712 compliant.

- Orderwire party line
- Dual tone multifrequency (DTMF) signaling
- User data channel (UDC)
 - Bit rate: 64 kbps, bidirectional
 - ITU-T G.703
 - Input/output impedance: 120 ohm
 - Termination: RJ-11 connectors
- Data communications channel (DCC)
 - Bit rate: 576 kbps
 - EIA/TIA-485/V11
 - Input/output impedance: 120 ohm
 - Termination: RJ-45 connectors
- ACC connection for additional alarm interfaces
 - Connection to AEP
- Power monitoring alarming states:
 - Power failure (0 to -38 VDC)
 - Undervoltage (-38 to -40.5 VDC)
 - Overvoltage (beyond -56.7 VDC)
- Environmental
 - Operating temperature: -40 to 149 degrees Fahrenheit (-40 to +65 degrees Celsius)
 - Operating humidity: 5 to 95 percent, noncondensing
 - Power consumption (including AEP, if used): 8.00 W, 0.17 A, 27.3 BTU/hr
- Dimensions
 - Height: 12.650 in. (321.3 mm)
 - Width: 0.716 in. (18.2 mm)
 - Depth: 9.000 in. (228.6 mm)
 - Card weight: 1.8 lb (0.82 kg)

A.4.7 AEP Specifications

The AEP has the following specifications:

- Alarm inputs
 - Number of inputs: 32

- Optocoupler isolated
- Label customer provisionable
- Severity customer provisionable
- Common 32 V output for all alarm inputs
- Each input limited to 2 mA
- Termination: 50-pin AMP champ connector
- Alarm outputs
 - Number of outputs: 16
 - Switched by opto MOS
 - Triggered by definable alarm condition
 - Maximum allowed open circuit voltage: 60 VDC
 - Maximum allowed closed circuit current: 100 mA
 - Termination: 50-pin AMP champ connector
- Environmental
 - Overvoltage protection: as in ITU-T G.703 Annex B
 - Operating temperature: -40 to +65 degrees Celsius
 - Operating humidity: 5 to 95 percent, noncondensing
 - Power consumption: 3.00 W max., from +5 VDC from AIC-I, 10.2 BTU/hr max.
- Dimensions of AEP board
 - Height: 0.79 in. (20 mm)
 - Width: 13.0 in. (330 mm)
 - Depth: 3.5 in. (89 mm)
 - Weight: 0.4 lb (0.18 kg)

A.5 Electrical Card Specifications

This section provides specifications for the EC1-12, DS1-14, DS1N-14, DS1/E1-56, DS3/EC1-48, DS3-12, DS3N-12, DS3i-N-12, DS3-12E, DS3N-12E, DS3XM-6, DS3XM-12, and filler cards.

For compliance information, refer to the *Cisco Optical Transport Products Safety and Compliance Information* document.

A.5.1 EC1-12 Card Specifications

The EC1-12 card has the following specifications:

- Input
 - Bit rate: 51.84 Mbps +/- 20 ppm
 - Frame format: SONET
 - Line code: B3ZS

- Termination: Unbalanced coaxial cable
- Input impedance: 75 ohms +/- 5 percent
- Cable loss: Max 450 feet 734A, RG-59, 728A/Max 79 feet RG-179
- AIS: TR-TSY-000191 compliant
- Output
 - Bit rate: 51.84 Mbps +/- 20 ppm
 - Frame format: SONET
 - Line code: B3ZS
 - Termination: Unbalanced coaxial cable
 - Input impedance: 75 ohms +/- 5 percent
 - Cable loss: Max 450 feet 734A, RG-59, 728A/Max 79 feet RG-179
 - AIS: TR-TSY-000191 compliant
 - Power level: -1.8 +/- 5.7 dBm
 - Pulse shape: ANSI T1.102-1988 Figure 8
 - Pulse amplitude: 0.36 to 0.85 V peak
 - Loopback modes: Terminal and facility
 - Line build out: 0 to 225 feet (0 to 68.8 meters); 226 to 450 feet (68.9 to 137.2 meters)
- Electrical interface: BNC or SMB connectors
- Operating temperature
 - C-Temp (15454-EC1-12): 0 to 131 degrees Fahrenheit (0 to +55 degrees Celsius)
 - I-Temp (15454-EC1-12-T): -40 to 149 degrees Fahrenheit (-40 to +65 degrees Celsius)



Note The I-Temp symbol is displayed on the faceplate of an I-Temp compliant card. A card without this symbol is C-Temp compliant.

- Operating humidity: 5 to 95 percent, noncondensing
- Power consumption: 36.60 W, 0.76 A, 124.97 BTU/hr
- Dimensions
 - Height: 12.650 in. (321.3 mm)
 - Width: 0.716 in. (18.2 mm)
 - Depth: 9.000 in. (228.6 mm)
 - Card weight: 2.0 lb (0.9 kg)

A.5.2 DS1-14 and DS1N-14 Card Specifications

The DS1-14 and DS1N-14 cards have the following specifications:

- Input
 - Bit rate: 1.544 Mbps +/- 32 ppm
 - Frame format: Off, SF (D4), ESF

- Line code: AMI, B8ZS
- Termination: Wire-wrap, AMP Champ
- Input impedance: 100 ohms
- Cable loss: Max 655 feet ABAM #22 AWG
- AIS: TR-TSY-000191 compliant
- Output
 - Bit rate: 1.544 Mbps +/- 32 ppm
 - Frame format: Off, SF (D4), ESF
 - Line code: AMI, B8ZS
 - Termination: Wire-wrap, AMP Champ
 - Input impedance: 100 ohms
 - Cable loss: Max 655 feet ABAM #22 AWG
 - AIS: TR-TSY-000191 compliant
 - Power level: 12.5 to 17.9 dBm centered at 772 KHz, -16.4 to -11.1 dBm centered at 1544 KHz
 - Pulse shape: Telcordia GR-499-CORE Figure 9-5
 - Pulse amplitude: 2.4 to 3.6 V peak
 - Loopback modes: Terminal and facility
- Electrical interface: BNC or SMB connectors
- Surge protection: Telcordia GR-1089
- Operating temperature
 - C-Temp (15454-DS1-14 and 15454-DS1N-14): 0 to 131 degrees Fahrenheit (0 to +55 degrees Celsius)
 - I-Temp (15454-DS1-14-T and 15454-DS1N-14-T): -40 to 149 degrees Fahrenheit (-40 to +65 degrees Celsius)



Note The I-Temp symbol is displayed on the faceplate of an I-Temp compliant card. A card without this symbol is C-Temp compliant.

- Operating humidity: 5 to 95 percent, noncondensing
- Power consumption: 12.60 W, 0.26 A, 43.02 BTU/hr
- Dimensions
 - Height: 12.650 in. (321.3 mm)
 - Width: 0.716 in. (18.2 mm)
 - Depth: 9.000 in. (228.6 mm)
 - Card weight: 1.8 lb (0.8 kg)

A.5.3 DS1/E1-56 Card Specifications

The DS1/E1-56 card has the following specifications:

- Input
 - Bit rate: 1.544 Mbps \pm 32 ppm (DS-1); 2.048 Mbps \pm 50ppm (E1)
 - Frame format: Off, SF (D4), ESF (DS-1); E1 multiframe, E1 CRC multiframe, and unframed (ITU) (E1)
 - Line code: AMI, B8ZS (DS-1); HDB3 (E1)
 - Termination: Balanced, twisted pair, #22/24 AWG
 - Input impedance: 100 ohms \pm 5 percent (DS1); 120 ohms \pm 5% (E1)
 - Cable loss: Max 655 feet ABAM #22/24 AWG (DS1); Compliant per ITU-T G.703 (E1)
 - AIS: TR-TSY-000191 compliant
- Output
 - Bit rate: 1.544 Mbps \pm 32 ppm (DS-1); 2.048 Mbps \pm 50ppm (E1)
 - Frame format: Off, SF (D4), ESF (DS-1); E1 multiframe, E1 CRC multiframe, and unframed (ITU) (E1)
 - Line code: AMI, B8ZS (DS-1); HDB3 (E1)
 - Termination: Balanced, twisted pair, #22/24 AWG
 - Input impedance: 100 ohms \pm 5 percent (DS1); 120 ohms \pm 5% (E1)
 - Cable loss: Max 655 feet ABAM #22/24 AWG (DS1); Compliant per ITU-T G.703 (E1)
 - AIS: TR-TSY-000191 compliant
 - Power level: 12.6 to 17.9 dBm centered at 772 KHz
 - Pulse shape: Telcordia GR-499-CORE Figure 9-5 (DS-1); ITU-T G.703, Figure 15 (E1)
 - Pulse amplitude: 2.4 to 3.6 V peak (DS-1); 2.7 to 3.3 V peak (E1)
 - Loopback modes: Terminal and facility
- Electrical interface: SCSI (UBIC) connectors. UBIC-H: DS-1 and E1; UBIC-V: DS-1 only.
- Surge protection: Telcordia GR-1089
- Operating temperature
 - I-Temp (15454-DS1E1-56): -40 to 149 degrees Fahrenheit (-40 to +65 degrees Celsius)



Note The I-Temp symbol is displayed on the faceplate of an I-Temp compliant card. A card without this symbol is C-Temp compliant.

- Operating humidity: 5 to 95 percent, noncondensing
- Power consumption: 36.00 W, 0.76 A, 124.97 BTU/hr
- Dimensions
 - Height: 12.650 in. (321.3 mm)
 - Width: 0.716 in. (18.2 mm)
 - Depth: 9.000 in. (228.6 mm)

- Card weight: 2.0 lb (0.9 kg)

A.5.4 DS3/EC1-48 Card Specifications

The DS3/EC1-48 card has the following specifications:

- Input
 - Bit rate: 44.736 Mbps +/- 20 ppm
 - Frame format: DS-3 ANSI T1.107-1988
 - Line code: B3ZS
 - Termination: Unbalanced coaxial cable
 - Input impedance: 75 ohms +/-5 percent
 - Cable loss: Max 450 feet with 734A or 728A, Max 79 feet with RG-179
 - AIS: TR-TSY-000191 compliant
- Output
 - Bit rate: 44.736 Mbps +/- 20 ppm
 - Frame format: DS-3 ANSI T1.107-1988
 - Line code: B3ZS
 - Termination: Unbalanced coaxial cable
 - Input impedance: 75 ohms +/-5 percent
 - Cable loss: Max 900 feet with 734A or 728A cable, Max 79 feet with RG-179
 - AIS: TR-TSY-000191 compliant
 - Power level: -1.8 to +5.7 dBm
 - Pulse shape: ANSI T1.102-1988 Figure 8
 - Pulse amplitude: 0.36 to 0.85 V peak
 - Loopback modes: Terminal and facility
 - Line build out: 0 to 225 feet (0 to 68.8 meters); 226 to 450 feet (68.9 to 137.2 meters)
- Electrical interface: BNC or SMB connectors
- Surge protection: Telcordia GR-1089
- Operating temperature:
 - I-Temp (15454-DS3_EC1-48): -40 to 149 degrees Fahrenheit (-40 to +65 degrees Celsius)



Note The I-Temp symbol is displayed on the faceplate of an I-Temp compliant card. A card without this symbol is C-Temp compliant.

- Operating humidity: 5 to 95 percent, noncondensing
- Power consumption: 60W, 1.25A at -48V, 95.6 BTU/hr
- Dimensions
 - Height: 12.650 in. (321.3 mm)
 - Width: 0.716 in. (18.2 mm)

- Depth: 9.000 in. (228.6 mm)
- Weight: 1.7 lb (0.7 kg)

A.5.5 DS3-12 and DS3N-12 Card Specifications

The DS3-12 and DS3N-12 cards have the following specifications:

- Input
 - Bit rate: 44.736 Mbps +/- 20 ppm
 - Frame format: DS-3 ANSI T1.107-1988
 - Line code: B3ZS
 - Termination: Unbalanced coaxial cable
 - Input impedance: 75 ohms +/-5 percent
 - Cable loss: Max 450 feet 734A, RG-59, 728A/Max 79 feet RG-179
 - AIS: TR-TSY-000191 compliant
 - Output
 - Bit rate: 44.736 Mbps +/- 20 ppm
 - Frame format: DS-3 ANSI T1.107-1988
 - Line code: B3ZS
 - Termination: Unbalanced coaxial cable
 - Input impedance: 75 ohms +/-5 percent
 - Cable loss: Max 450 feet 734A, RG-59, 728A/Max 79 feet RG-179
 - AIS: TR-TSY-000191 compliant
 - Power level: -1.8 to +5.7 dBm
 - Pulse shape: ANSI T1.102-1988 Figure 8
 - Pulse amplitude: 0.36 to 0.85 V peak-to-peak
 - Loopback modes: Terminal and facility
 - Line build out: 0 to 225 feet (0 to 68.8 meters); 226 to 450 feet (68.9 to 137.2 meters)
 - Electrical interface: BNC or SMB connectors
 - Surge protection: Telcordia GR-1089
 - Operating temperature
 - C-Temp (15454-DS3-12 and 15454-DS3N-12): 0 to 131 degrees Fahrenheit (0 to +55 degrees Celsius)
 - I-Temp (15454-DS3-12-T and 15454-DS3N-12-T): -40 to 149 degrees Fahrenheit (-40 to +65 degrees Celsius)
- 

Note The I-Temp symbol is displayed on the faceplate of an I-Temp compliant card. A card without this symbol is C-Temp compliant.

- Operating humidity: 5 to 95 percent, noncondensing

- Power consumption: 38.20 W, 0.79 A, 130.43 BTU/hr
- Dimensions
 - Height: 12.650 in. (321.3 mm)
 - Width: 0.716 in. (18.2 mm)
 - Depth: 9.000 in. (228.6 mm)
 - DS3-12 card weight: 1.7 lb (0.7 kg)
 - DS3N-12 card weight: 1.8 lb (0.8 kg)

A.5.6 DS3i-N-12 Card Specifications

The DS3i-N-12 card has the following specifications:

- Input
 - Bit rate: 44.736 Mbps +/-20 ppm
 - Frame format: ITU-T G.704, ITU-T G.752/DS-3 ANSI T1.107-1988
 - Line code: B3ZS
 - Termination: Unbalanced coaxial cable
 - Input impedance: 75 ohms +/- 5 percent
 - Cable loss:
 - Maximum 137 m (450 ft): 734A, RG59, 728A
 - Maximum 24 m (79 ft): RG179
 - AIS: ITU-T G.704 compliant
- Output
 - Bit rate: 44.736 Mbps +/- 20 ppm
 - Frame format: ITU-T G.704, ITU-T G.752/DS-3 ANSI T1.107-1988
 - Line code: B3ZS
 - Termination: Unbalanced coaxial cable
 - Output impedance: 75 ohms +/-5 percent
 - AIS: ITU-T G.704 compliant
 - Power level: -1.8 to +5.7 dBm



Note The power level is for a signal of all ones and is measured at a center frequency of 22.368 MHz (3 +/-1 kHz) bandwidth.)

- Pulse shape: ITU-T G.703, Figure 14/ANSI T1.102-1988, Figure 8
- Pulse amplitude: 0.36 to 0.85 V peak-to-peak
- Loopback modes: Terminal and facility
- Line build out: 0 to 225 feet (0 to 68.8 meters); 226 to 450 feet (68.9 to 137.2 meters)
- Electrical interface connectors: SMB, BNC
- Environmental

- Overvoltage protection: As in ITU-T G.703 Annex B
- Operating temperature: +23 to +113 degrees Fahrenheit (-5 to +45 degrees Celsius)
- Operating humidity: 5 to 95 percent, noncondensing
- Power consumption: 26.80 W, 0.56 A at -48 V, 91.5 BTU/hr
- Dimensions
 - Height: 12.650 in. (321.3 mm)
 - Width: 0.716 in. (18.2 mm)
 - Depth: 9.000 in. (228.6 mm)
 - Depth with backplane connector: 9.250 in. (235 mm)
 - Weight not including clam shell: 1.9 lb (0.8 kg)

A.5.7 DS3-12E and DS3N-12E Card Specifications

The DS3-12E and DS3N-12E cards have the following specifications:

- Input
 - Bit rate: 44.736 Mbps +/- 20 ppm
 - Frame format: DS-3 ANSI T1.107-1988
 - Line code: B3ZS
 - Termination: Unbalanced coaxial cable
 - Input impedance: 75 ohms +/-5 percent
 - Cable loss: Max 450 feet 734A, RG-59, 728A/Max 79 feet RG-179
 - AIS: TR-TSY-000191 compliant
- Output
 - Bit rate: 44.736 Mbps +/- 20 ppm
 - Frame format: DS-3 ANSI T1.107-1988
 - Line code: B3ZS
 - Termination: Unbalanced coaxial cable
 - Input impedance: 75 ohms +/-5 percent
 - Cable loss: Max 450 feet 734A, RG-59, 728A/Max 79 feet RG-179
 - AIS: TR-TSY-000191 compliant
 - Power level: -1.8 to +5.7 dBm



Note The power level is for a signal of all ones and is measured at a center frequency of 22.368 MHz (3 +/-1 kHz) bandwidth.

- Pulse shape: ANSI T1.102-1988 Figure 8
- Pulse amplitude: 0.36 to 0.85 V peak-to-peak
- Loopback modes: Terminal and facility
- Line build out: 0 to 225 feet (0 to 68.8 meters); 226 to 450 feet (68.9 to 137.2 meters)

- Electrical interface: Connectors: BNC or SMB
- Surge protection: Telcordia GR-1089
- Operating temperature: I-Temp (15454-DS3-12E-T and 15454-DS3N-12E-T): –40 to 149 degrees Fahrenheit (–40 to +65 degrees Celsius)



Note The I-Temp symbol is displayed on the faceplate of an I-Temp compliant card. A card without this symbol is C-Temp compliant.

- Operating humidity: 5 to 95 percent, noncondensing
- Power consumption: 26.80 W, 0.56 A, 91.51 BTU/hr
- Dimensions
 - Height: 12.650 in. (321.3 mm)
 - Width: 0.716 in. (18.2 mm)
 - Depth: 9.000 in. (228.6 mm)
 - Depth with backplane connector: 9.250 in. (235.0 mm)
 - DS3-12E card weight: 1.8 lb (0.8 kg)
 - DS3N-12E card weight: 1.9 lb (0.8 kg)

A.5.8 DS3XM-12 Card Specifications

The DS3XM-12 card has the following specifications:

- Input
 - Bit rate: 44.736 Mbps +/-20 ppm
 - Frame format: DS-3 ANSI T1.107-1988
 - Line code: B3ZS
 - Termination: Unbalanced coaxial cable
 - Input impedance: 75 ohms +/-5 percent
 - Cable loss: Max 450 feet 734A, RG-59, 728A/Max 79 feet RG-179
 - AIS: TR-TSY-000191 compliant
- Output
 - Bit rate: 44.736 Mbps +/- 20 ppm
 - Frame format: DS-3 ANSI T1.107-1988
 - Line code: B3ZS
 - Termination: Unbalanced coaxial cable
 - Input impedance: 75 ohms +/-5 percent
 - Cable loss: Max 450 feet 734A, RG-59, 728A/Max 79 feet RG-179
 - AIS: TR-TSY-000191 compliant
 - Power level: –1.8 to +5.7 dBm
 - Pulse shape: ANSI T1.102-1988 Figure 8

- Pulse amplitude: 0.36 to 0.85 V peak-to-peak
- Loopback modes: Terminal and facility
- Line build out: 0 to 225 feet (0 to 68.8 meters); 226 to 450 feet (68.9 to 137.2 meters)
- Interface: BNC, SMB, UBIC and MiniBNC connectors
- Surge protection: Telcordia GR-1089
- Operating temperature:
 - I-Temp (15454-DS3XM-12): -40 to 149 degrees Fahrenheit (-40 to +65 degrees Celsius)



Note The I-Temp symbol is displayed on the faceplate of an I-Temp compliant card. A card without this symbol is C-Temp compliant.

- Operating humidity: 5 to 95 percent, noncondensing
- Power consumption: 34 W, 0.71A at -48 V, 116.1 BTU/hr
- Dimensions
 - Height: 12.65 in. (321.3 mm)
 - Width: 0.716 in. (18.2 mm)
 - Depth: 9.00 in. (228.6 mm)
 - Card weight: 1.8 lb (0.8 kg)

A.5.9 DS3XM-6 Card Specifications

The DS3XM-6 card has the following specifications:

- Input
 - Bit rate: 44.736 Mbps +/-20 ppm
 - Frame format: DS-3 ANSI T1.107-1988
 - Line code: B3ZS
 - Termination: Unbalanced coaxial cable
 - Input impedance: 75 ohms +/-5 percent
 - Cable loss: Max 450 feet 734A, RG-59, 728A/Max 79 feet RG-179
 - AIS: TR-TSY-000191 compliant
- Output
 - Bit rate: 44.736 Mbps +/- 20 ppm
 - Frame format: DS-3 ANSI T1.107-1988
 - Line code: B3ZS
 - Termination: Unbalanced coaxial cable
 - Input impedance: 75 ohms +/-5 percent
 - Cable loss: Max 450 feet 734A, RG-59, 728A/Max 79 feet RG-179
 - AIS: TR-TSY-000191 compliant
 - Power level: -1.8 to +5.7 dBm

- Pulse shape: ANSI T1.102-1988 Figure 8
- Pulse amplitude: 0.36 to 0.85 V peak-to-peak
- Loopback modes: Terminal and facility
- Line build out: 0 to 225 feet (0 to 68.8 meters); 226 to 450 feet (68.9 to 137.2 meters)
- Interface: BNC or SMB connectors
- Surge protection: Telcordia GR-1089
- Operating temperature:
 - C-Temp (15454-DS3XM-6): 0 to 131 degrees Fahrenheit (0 to +55 degrees Celsius)
 - I-Temp (15454-DS3XM-6-T): –40 to 149 degrees Fahrenheit (–40 to +65 degrees Celsius)



Note The I-Temp symbol is displayed on the faceplate of an I-Temp compliant card. A card without this symbol is C-Temp compliant.

- Operating humidity: 5 to 95 percent, noncondensing
- Power consumption: 20 W, 0.42 A, 68 BTU/hr
- Dimensions
 - Height: 12.650 in. (321.3 mm)
 - Width: 0.716 in. (18.2 mm)
 - Depth: 9.000 in. (228.6 mm)
 - Card weight: 1.8 lb (0.8 kg)

A.5.10 FILLER Card Specifications

The FILLER cards have the following specifications:

- Environmental
 - Operating temperature:
 - C-Temp: -40 to +149 degree Fahrenheit (-40 to +65 degrees Celsius)
 - Operating humidity: 5 to 95 percent, noncondensing
- Dimensions
 - Height: 12.650 in. (321.3 mm)
 - Width: 0.716 in. (18.2 mm)
 - Depth: 9.000 in. (228.6 mm)
 - Card weight: 0.4 lb (0.19 kg)

A.6 Optical Card Specifications

This section provides specifications for the OC3 IR4/STM1 SH 1310 (four-port), OC3 IR/STM1 SH 1310-8 (eight-port), OC12 IR/STM4 SH 1310, OC12 LR/STM4 LH 1310, OC12 LR STM4 LH 1550, OC12 IR/STM4 SH 1310-4 (four-port), OC48 IR 1310, OC48 LR 1550, OC48 IR/STM16 SH AS 1310,

OC48 LR/STM16 LH AS 1550, OC48 ELR 100 GHz, OC48 ELR 200 GHz, OC192 SR/STM64 IO 1310, OC192 IR/STM64 SH 1550, OC192 LR/STM64 LH 1550, OC192 LR/STM64 LH ITU 15xx.xx, 15454_MRC-12 (12-port), OC192SR1/STM64IO Short Reach, and OC192/STM64 Any Reach cards.

For compliance information, refer to the *Cisco Optical Transport Products Safety and Compliance Information*.

A.6.1 OC3 IR 4/STM1 SH 1310 Card Specifications

The OC3 IR 4/STM1 SH 1310 card has the following specifications:

- Line
 - Bit rate: 155.52 Mbps
 - Code: Scrambled non-return to zero (NRZ)
 - Fiber: 1310-nm single-mode
 - Loopback modes: Terminal and facility
 - Connector: SC
 - Compliance: Telcordia GR-253-CORE, ITU-T G.707, ITU-T G.957
- Transmitter
 - Maximum transmitter output power: –8 dBm
 - Minimum transmitter output power: –15 dBm
 - Center wavelength: 1274 to 1356 nm
 - Nominal wavelength: 1310 nm
 - Transmitter: Fabry Perot (FP) laser
 - Extinction Ratio: 8.2 dB
 - Dispersion Ratio: 96 ps/nm
- Receiver
 - Maximum receiver level: –8 dBm at BER 1×10^{-12}
 - Minimum receiver level: –28 dBm at BER 1×10^{-12}
 - Receiver: InGaAs/InP photodetector
 - Link loss budget: 13 dB
 - Receiver input wavelength range: 1274 to 1356 nm
 - Jitter tolerance: Telcordia GR-253/ITU-T G.823 compliant
- Environmental
 - Operating temperature:
 - C-Temp (15454-OC34IR1310): +23 to +113 degrees Fahrenheit (–5 to +45 degrees Celsius)
 - I-Temp (15454-OC34I13-T): –40 to 149 degrees Fahrenheit (–40 to +65 degrees Celsius)
 - Operating humidity: 5 to 95 percent, noncondensing
 - Power consumption: 19.20 W, 0.40 A at –48 V, 65.56 BTU/hr
- Dimensions
 - Height: 12.650 in. (321.3 mm)

- Width: 0.716 in. (18.2 mm)
- Depth: 9.000 in. (228.6 mm)
- Depth with backplane connector: 9.250 in. (235 mm)
- Weight not including clam shell: 1.0 lb (0.4 kg)

A.6.2 OC3 IR/STM1SH 1310-8 Card Specifications

The OC3 IR/STM1SH 1310-8 card has the following specifications:

- Line
 - Bit rate: 155.52 Mbps
 - Code: Scrambled NRZ
 - Fiber: 1310-nm single-mode
 - Loopback modes: Terminal and facility
 - Connector: LC
 - Compliance: Telcordia GR-253-CORE, ITU-T G.707, ITU-T G.957
- Transmitter
 - Maximum transmitter output power: -8 dBm
 - Minimum transmitter output power: -15 dBm
 - Center wavelength: 1261 to 1360 nm
 - Nominal wavelength: 1310 nm
 - Transmitter: Fabry Perot laser
 - Extinction ratio: 8.2 dB
 - Dispersion tolerance: 96 ps/nm
- Receiver
 - Maximum receiver level: -8 dBm at BER $1 * 10 \text{ exp} - 12$
 - Minimum receiver level: -28 dBm at BER $1 * 10 \text{ exp} - 12$
 - Receiver: InGaAs/InP photodetector
 - Link loss budget: 13 dB
 - Receiver input wavelength range: 1261 to 1360 nm
 - Jitter tolerance: Telcordia GR-253/ITU-T G.823 compliant
- Environmental
 - Operating temperature: +23 to +113 degrees Fahrenheit (-5 to +45 degrees Celsius)
 - Operating humidity: 5 to 95 percent, noncondensing
 - Power consumption: 23.00 W, 0.48 A at -48 V, 78.5 BTU/hr
- Dimensions
 - Height: 12.650 in. (321.3 mm)
 - Width: 0.716 in. (18.2 mm)
 - Depth: 9.000 in. (228.6 mm)

- Depth with backplane connector: 9.250 in. (235 mm)
- Weight not including clam shell: 1.0 lb (0.4 kg)

A.6.3 OC12 IR/STM4 SH 1310 Card Specifications

The OC12 IR/STM4 SH 1310 card has the following specifications:

- Line
 - Bit rate: 622.08 Mbps
 - Code: Scrambled NRZ
 - Fiber: 1310-nm single-mode
 - Loopback modes: Terminal and facility
 - Connectors: SC
 - Compliance: Telcordia GR-253-CORE, ITU-T G.707, ITU-T G.957
- Transmitter
 - Maximum transmitter output power: -8 dBm
 - Minimum transmitter output power: -15 dBm
 - Center wavelength: 1274 to 1356 nm
 - Nominal wavelength: 1310 nm
 - Transmitter: Fabry Perot laser
 - Extinction ratio: 8.2 dB
 - Dispersion tolerance: 96 ps/nm
- Receiver
 - Maximum receiver level: -8 dBm at BER $1 * 10 \text{ exp} - 12$
 - Minimum receiver level: -28 dBm at BER $1 * 10 \text{ exp} - 12$
 - Receiver: InGa As/InP photodetector
 - Link loss budget: 13 dB
 - Receiver input wavelength range: 1274 to 1356 nm
 - Jitter tolerance: Telcordia GR-253/ITU-T G.823 compliant
- Environmental
 - Operating temperature:
 - C-Temp (15454-OC121IR1310): +23 to +131 degrees Fahrenheit (-5 to +55 degrees Celsius)
 - I-Temp (15454-OC121I13-T): -40 to +149 degrees Fahrenheit (-40 to +65 degrees Celsius)
 - Operating humidity: 5 to 95 percent, noncondensing
 - Power consumption: 10.90 W, 0.23 A at -48 V, 37.22 BTU/hr
- Dimensions
 - Height: 12.650 in. (321.3 mm)
 - Width: 0.716 in. (18.2 mm)
 - Depth: 9.000 in. (228.6 mm)

- Weight not including clam shell: 1.4 lb (0.6 kg)

A.6.4 OC12 LR/STM4 LH 1310 Card Specifications

The OC12 LR/STM4 LH 1310 card has the following specifications:

- Line
 - Bit rate: 622.08 Mbps
 - Code: Scrambled NRZ
 - Fiber: 1310-nm single-mode
 - Loopback modes: Terminal and facility
 - Connectors: SC
 - Compliance: Telcordia SONET, Telcordia GR-253-CORE, ITU-T G.707, ITU-T G.957
- Transmitter
 - Maximum transmitter output power: +2 dBm
 - Minimum transmitter output power: –3 dBm
 - Center wavelength: 1280 to 1335 nm
 - Nominal wavelength: 1310 nm
 - Transmitter: Distributed feedback (DFB) laser
 - Extinction ratio: 10 dB
 - Dispersion tolerance: 190 ps/nm
- Receiver
 - Maximum receiver level: –8 dBm at BER 1×10^{-12}
 - Minimum receiver level: –28 dBm at BER 1×10^{-12}
 - Receiver: InGaAs/InP photodetector
 - Link loss budget: 25 dB
 - Receiver input wavelength range: 1280 to 1335 nm
 - Jitter tolerance: Telcordia GR-253/ITU-T G.823 compliant
- Environmental
 - Operating temperature:
 - C-Temp (15454-OC121LR1310): +23 to +131 degrees Fahrenheit (–5 to +55 degrees Celsius)
 - I-Temp (15454-OC121L13-T): –40 to +149 degrees Fahrenheit (–40 to +65 degrees Celsius)
 - Operating humidity: 5 to 95 percent, noncondensing
 - Power consumption: 9.28 W, 0.25 A, 41 BTU/hr
- Dimensions
 - Height: 12.650 in. (321.3 mm)
 - Width: 0.716 in. (18.2 mm)
 - Depth: 9.000 in. (228.6 mm)
 - Weight not including clam shell: 1.4 lb (0.6 kg)

A.6.5 OC12 LR/STM4 LH 1550 Card Specifications

The OC12 LR/STM4 LH 1550 card has the following specifications:

- Line
 - Bit rate: 622.08 Mbps
 - Code: Scrambled NRZ
 - Fiber: 1550-nm single-mode
 - Loopback modes: Terminal and facility
 - Connectors: SC
 - Compliance: Telcordia SONET, Telcordia GR-253-CORE, ITU-T G.707, ITU-T G.957
- Transmitter
 - Maximum transmitter output power: +2 dBm
 - Minimum transmitter output power: –3 dBm
 - Center wavelength: 1480 to 1580 nm
 - Nominal wavelength: 1550 nm
 - Transmitter: DFB laser
 - Dispersion tolerance: 1440 ps/nm
- Receiver
 - Maximum receiver level: –8 dBm at BER $1 * 10 \text{ exp} - 12$
 - Minimum receiver level: –28 dBm at BER $1 * 10 \text{ exp} - 12$
 - Receiver: InGaAs/InP photodetector
 - Link loss budget: 25 dB
 - Receiver input wavelength range: 1480 to 1580 nm
 - Jitter tolerance: Telcordia GR-253/ITU-T G.823 compliant
- Environmental
 - Operating temperature:
 - C-Temp (15454-OC121LR1550): +23 to +131 degrees Fahrenheit (–5 to +55 degrees Celsius)
 - I-Temp (15454-OC121L15-T): –40 to +149 degrees Fahrenheit (–40 to +65 degrees Celsius)
 - Operating humidity: 5 to 95 percent, noncondensing
 - Power consumption: 9.28 W, 0.19 A, 31.68 BTU/hr
- Dimensions
 - Height: 12.650 in. (321.3 mm)
 - Width: 0.716 in. (18.2 mm)
 - Depth: 9.000 in. (228.6 mm)
 - Weight not including clam shell: 1.4 lb (0.6 kg)

A.6.6 OC12 IR/STM4 SH 1310-4 Specifications

The OC12 IR/STM4 SH 1310-4 card has the following specifications:

- Line
 - Bit rate: 622.08 Mbps
 - Code: Scrambled NRZ
 - Fiber: 1310-nm single-mode
 - Loopback modes: Terminal and facility
 - Connector: SC
 - Compliance: Telcordia GR-253-CORE, ITU-T G.707, ITU-T G.957
- Transmitter
 - Maximum transmitter output power: –8 dBm
 - Minimum transmitter output power: –15 dBm
 - Center wavelength: 1274 to 1356 nm
 - Nominal wavelength: 1310 nm
 - Transmitter: Fabry Perot laser
 - Extinction ratio: 10 dB
 - Dispersion tolerance: 190 ps/nm
- Receiver
 - Maximum receiver level: –8 dBm
 - Minimum receiver level: –30 dBm
 - Receiver: InGaAs/InP photodetector
 - Link loss budget: 15 dB
 - Receiver input wavelength range: 1274 to 1356 nm
 - Jitter tolerance: Telcordia GR-253/ITU-T G.823 compliant
- Operating temperature
 - C-Temp: +23 to +131 degrees Fahrenheit (–5 to +55 degrees Celsius)
- Operating humidity
 - 5 to 95 percent, noncondensing
- Power consumption
 - 28 W, 0.58 A, 100 BTU/hr
- Dimensions
 - Height: 12.650 in. (321.3 mm)
 - Width: 0.716 in. (18.2 mm)
 - Depth: 9.000 in. (228.6 mm)
 - Weight not including clam shell: 1.0 lb (0.4 kg)

**Note**

Minimum transmit power, minimum receive power, and link loss budget might exceed standard specifications.

A.6.7 OC48 IR 1310 Card Specifications

The OC48 IR 1310 card has the following specifications:

- Line
 - Bit rate: 2.49 Gbps
 - Code: Scrambled NRZ
 - Fiber: 1310-nm single-mode
 - Loopback modes: Terminal and facility
 - Connectors: SC
 - Compliance: Telcordia GR-253-CORE
- Transmitter
 - Maximum transmitter output power: 0 dBm
 - Minimum transmitter output power: –5 dBm
 - Center wavelength: 1280 to 1350 nm
 - Nominal wavelength: 1310 nm
 - Transmitter: Uncooled direct modulated DFB
- Receiver
 - Maximum receiver level: 0 dBm
 - Minimum receiver level: –18 dBm
 - Receiver: InGaAs InP photodetector
 - Link loss budget: 13 dB minimum
 - Receiver input wavelength range: 1280 to 1350 nm
- Environmental
 - Operating temperature:
 - C-Temp (15454-OC481IR1310): +23 to +131 degrees Fahrenheit (–5 to +55 degrees Celsius)
 - Operating humidity: 5 to 95 percent, noncondensing
 - Power consumption: 32.20 W, 0.67 A, 109.94 BTU/hr
- Dimensions
 - Height: 12.650 in. (321.3 mm)
 - Width: 0.716 in. (18.2 mm)
 - Depth: 9.000 in. (228.6 mm)
 - Weight not including clam shell: 1.8 lb (0.8 kg)

A.6.8 OC48 LR 1550 Card Specifications

The OC48 LR 1550 card has the following specifications:

- Line
 - Bit rate: 2.49 Gbps
 - Code: Scrambled NRZ
 - Fiber: 1550-nm single-mode
 - Loopback modes: Terminal and facility
 - Connectors: SC
 - Compliance: Telcordia GR-253-CORE
- Transmitter
 - Maximum transmitter output power: +3 dBm
 - Minimum transmitter output power: –2 dBm
 - Center wavelength: 1520 to 1580 nm
 - Nominal wavelength: 1550 nm
 - Transmitter: DFB laser
- Receiver
 - Maximum receiver level: –8 dBm
 - Minimum receiver level: –28 dBm
 - Receiver: InGaAs avalanche photo diode (APD) photodetector
 - Link loss budget: 26 dB minimum, with 1 dB dispersion penalty
 - Receiver input wavelength range: 1520 to 1580 nm
- Environmental
 - Operating temperature:
 - C-Temp (15454-OC481LR1550): +23 to +131 degrees Fahrenheit (–5 to +55 degrees Celsius)
 - Operating humidity: 5 to 95 percent, noncondensing
 - Power consumption: 26.80 W, 0.56 A, 91.50 BTU/hr
- Dimensions
 - Height: 12.650 in. (321.3 mm)
 - Width: 0.716 in. (18.2 mm)
 - Depth: 9.000 in. (228.6 mm)
 - Weight not including clam shell: 1.8 lb (0.8 kg)

A.6.9 OC48 IR/STM16 SH AS 1310 Card Specifications

The OC48 IR/STM16 SH AS 1310 card has the following specifications:

- Line
 - Bit rate: 2.49 Gbps

- Code: Scrambled NRZ
- Fiber: 1310-nm single-mode
- Loopback modes: Terminal and facility
- Connectors: SC
- Compliance: Telcordia GR-253-CORE, ITU-T G.707, ITU-T G.957
- Transmitter
 - Maximum transmitter output power: 0 dBm
 - Minimum transmitter output power: -5 dBm
 - Center wavelength: 1280 to 1350 nm
 - Nominal wavelength: 1310 nm
 - Transmitter: DFB laser
 - Dispersion tolerance: 96 ps/nm
- Receiver
 - Maximum receiver level: 0 dBm
 - Minimum receiver level: -18 dBm
 - Receiver: InGaAs InP photodetector
 - Link loss budget: 13 dB minimum
 - Receiver input wavelength range: 1280 to 1350 nm
 - Jitter tolerance: Telcordia GR-253/ITU-T G.823 compliant
- Environmental
 - Operating temperature:
 - C-Temp (15454-OC481IR1310A): +23 to +131 degrees Fahrenheit (-5 to +55 degrees Celsius)
 - Operating humidity: 5 to 95 percent, noncondensing
 - Power consumption: 37.20 W, 0.77 A, 127.01 BTU/hr
- Dimensions
 - Height: 12.650 in. (321.3 mm)
 - Width: 0.716 in. (18.2 mm)
 - Depth: 9.000 in. (228.6 mm)
 - Weight not including clam shell: 2.2 lb (0.9 kg)

A.6.10 OC48 LR/STM16 LH AS 1550 Card Specifications

The OC48 LR/STM16 SH AS 1550 card has the following specifications:

- Line
 - Bit rate: 2.49 Gbps
 - Code: Scrambled NRZ
 - Fiber: 1550-nm single-mode
 - Loopback modes: Terminal and facility

- Connectors: SC
- Compliance: Telcordia GR-253-CORE, ITU-T G.707, ITU-T G.957
- Transmitter
 - Maximum transmitter output power: +3 dBm
 - Minimum transmitter output power: -2 dBm
 - Center wavelength: 1520 to 1580 nm
 - Nominal wavelength: 1550 nm
 - Transmitter: DFB laser
 - Dispersion ratio: 3600 ps/nm
- Receiver
 - Maximum receiver level: -8 dBm
 - Minimum receiver level: -28 dBm
 - Receiver: InGaAs APD photodetector
 - Link loss budget: 26 dB minimum, with 1 dB dispersion penalty
 - Receiver input wavelength range: 1520 to 1580 nm
 - Jitter tolerance: Telcordia GR-253/ITU-T G.823 compliant
- Environmental
 - Operating temperature:
 - C-Temp (15454-OC481LR1550A): +23 to +131 degrees Fahrenheit (-5 to +55 degrees Celsius)
 - Operating humidity: 5 to 95 percent, noncondensing
 - Power consumption: 37.20 W, 0.77 A, 127.01 BTU/hr
- Dimensions
 - Height: 12.650 in. (321.3 mm)
 - Width: 0.716 in. (18.2 mm)
 - Depth: 9.000 in. (228.6 mm)
 - Weight not including clam shell: 2.2 lb (0.9 kg)

A.6.11 OC48 ELR/STM 16 EH 100 GHz Card Specifications

The OC48 ELR 100 GHz card has the following specifications:

- Line
 - Bit rate: 2.49 Gbps
 - Code: Scrambled NRZ
 - Fiber: 1550-nm single-mode
 - Loopback modes: Terminal and facility
 - Connectors: SC
 - Compliance: Telcordia GR-253-CORE, ITU-T G.692, ITU-T G.958

- Transmitter
 - Maximum transmitter output power: 0 dBm
 - Minimum transmitter output power: –2 dBm
 - Center wavelength accuracy: +/- 0.12 nm
 - Transmitter: Electro-absorption laser
 - Dispersion tolerance: 5400 ps/nm
- Receiver
 - Maximum receiver level: –9 dBm
 - Minimum receiver level: –27 dBm at 1E–12 BER
 - Receiver: InGaAs APD photodetector
 - Link loss budget: 25 dB minimum at 1E–12 BER (not including the power dispersion penalty)
 - Dispersion penalty: 2 dB for a dispersion of up to 5400 ps/nm
 - Receiver input wavelength range: 1520 to 1580 nm
 - Jitter tolerance: Telcordia GR-253/ITU-T G.823 compliant
- Environmental
 - Operating temperature: C-Temp: +23 to +131 degrees Fahrenheit (–5 to +55 degrees Celsius)
 - Operating humidity: 5 to 95 percent, noncondensing
 - Power consumption: 31.20 W, 0.65 A, 106.53 BTU/hr
- Dimensions
 - Height: 12.650 in. (321.3 mm)
 - Width: 0.716 in. (18.2 mm)
 - Depth: 9.000 in. (228.6 mm)
 - Weight not including clam shell: 2.4 lb (1.1 kg)

A.6.12 OC48 ELR 200 GHz Card Specifications

The OC48 ELR 200 GHz card has the following specifications:

- Line
 - Bit rate: 2.49 Gbps
 - Code: Scrambled NRZ
 - Fiber: 1550-nm single-mode
 - Loopback modes: Terminal and facility
 - Connectors: SC
 - Compliance: Telcordia GR-253-CORE, ITU-T G692, ITU-T G958
- Transmitter
 - Maximum transmitter output power: 0 dBm
 - Minimum transmitter output power: –2 dBm
 - Center wavelength accuracy: +/- 0.25 nm

- Transmitter: Electro-absorption laser
 - Dispersion tolerance: 3600 ps/nm
- Receiver
 - Maximum receiver level: -8 dBm
 - Minimum receiver level: -28 dBm
 - Receiver: InGaAs APD photodetector
 - Link loss budget: 26 dB minimum, with 1 dB dispersion penalty
 - Receiver input wavelength range: 1520 to 1580 nm
 - Jitter tolerance: Telcordia GR-253/ITU-T G.823 compliant
- Environmental
 - Operating temperature:
 - C-Temp: +23 to +131 degrees Fahrenheit (-5 to +55 degrees Celsius)
 - Operating humidity: 5 to 95 percent, noncondensing
 - Power consumption: 31.20 W, 0.65 A, 106.53 BTU/hr
- Dimensions
 - Height: 12.650 in. (321.3 mm)
 - Width: 0.716 in. (18.2 mm)
 - Depth: 9.000 in. (228.6 mm)
 - Weight not including clam shell: 2.9 lb (1.3 kg)

A.6.13 OC192 SR/STM64 IO 1310 Card Specifications

The OC192 SR/STM64 IO 1310 card has the following specifications:

- Line
 - Bit rate: 9.95328 Gbps
 - Code: Scrambled NRZ
 - Fiber: 1310-nm single-mode
 - Maximum chromatic dispersion allowance: 6.6 ps/nm
 - Loopback modes: Terminal and facility
 - Connectors: SC
 - Compliance: Telcordia GR-253-CORE, ITU-T G.707, ITU-T G.957, ITU-T G.691
- Transmitter
 - Maximum transmitter output power: -1 dBm
 - Minimum transmitter output power: -6 dBm
 - Center wavelength: 1290 to 1330 nm
 - Nominal wavelength: 1310 nm
 - Transmitter: Directly modulated laser
- Receiver

- Maximum receiver level: -1 dBm at BER $1 * 10 \text{ exp} - 12$
- Minimum receiver level: -11 dBm at BER $1 * 10 \text{ exp} - 12$
- Receiver: PIN diode
- Link loss budget: 5 dB minimum, plus 1 dB dispersion penalty at BER = $1 * 10 \text{ exp} - 12$ including dispersion
- Receiver input wavelength range: 1290 to 1330 nm
- Dispersion tolerance: 6.6 ps/nm
- Environmental
 - Operating temperature: +23 to +131 degrees Fahrenheit (-5 to +55 degrees Celsius)
 - Operating humidity: 5 to 95 percent, noncondensing
 - Power consumption: 47.00 W, 0.98 A at -48 V, 160.5 BTU/hr
- Dimensions
 - Height: 12.650 in. (321.3 mm)
 - Width: 0.716 in. (18.2 mm)
 - Depth: 9.000 in. (228.6 mm)
 - Depth with backplane connector: 9.250 in. (235 mm)
 - Weight not including clam shell: 3.1 lb (1.3 kg)

A.6.14 OC192 IR/STM64 SH 1550 Card Specifications

The OC192 IR/STM64 SH 1550 card has the following specifications:

- Line
 - Bit rate: 9.95328 Gbps
 - Code: Scrambled NRZ
 - Fiber: 1550-nm single-mode
 - Maximum chromatic dispersion allowance: 800 ps/nm
 - Loopback modes: Terminal and facility



Note You must use a 3 to 15 dB fiber attenuator (5 dB recommended) when working with the OC192 IR/STM64 SH 1550 card in a loopback. Do not use fiber loopbacks with the OC192 IR/STM64 SH 1550 card. Using fiber loopbacks can cause irreparable damage to the OC192 IR/STM64 SH 1550 card.

- Connectors: SC
- Compliance: Telcordia GR-253-CORE, ITU-T G.707, ITU-T G.957, ITU-T G.691
- Transmitter
 - Maximum transmitter output power: +2 dBm
 - Minimum transmitter output power: -1 dBm
 - Center wavelength: 1530 to 1565 nm

- Nominal wavelength: 1550 nm
- Transmitter: Cooled EA (European accreditation) modulated laser
- Receiver
 - Maximum receiver level: -1 dBm at BER $1 * 10 \text{ exp} - 12$
 - Minimum receiver level: -14 dBm at BER $1 * 10 \text{ exp} - 12$
 - Receiver: PIN diode
 - Link loss budget: 13 dB minimum, plus 2 dB dispersion penalty at BER = $1 * 10 \text{ exp} - 12$ including dispersion
 - Receiver input wavelength range: 1530 to 1565 nm
 - Dispersion tolerance: 800 ps/nm
- Environmental
 - Operating temperature: +23 to +131 degrees Fahrenheit (-5 to +55 degrees Celsius)
 - Operating humidity: 5 to 95 percent, noncondensing
 - Power consumption: 50.00 W, 1.04 A at -48 V, 170.7 BTU/hr
- Dimensions
 - Height: 12.650 in. (321.3 mm)
 - Width: 0.716 in. (18.2 mm)
 - Depth: 9.000 in. (228.6 mm)
 - Depth with backplane connector: 9.250 in. (235 mm)
 - Weight not including clam shell: 3.1 lb (1.3 kg)

A.6.15 OC192 LR/STM64 LH 1550 Card Specifications

The OC192 LR/STM64 LH 1550 card has the following specifications:

- Line
 - Bit rate: 9.95328 Gbps
 - Code: Scrambled NRZ
 - Fiber: 1550-nm single-mode
 - Loopback modes: Terminal and facility



Note

You must use a fiber attenuator when connecting a fiber loopback to an OC192 LR/STM64 LH 1550 card. Use a 19 to 24 dB attenuator for 15454-OC192LR1550 or a 14 to 28 dB attenuator for 15454-OC192-LR2 (20 dB is recommended). Never connect a direct fiber loopback.

- Connectors: SC
- Compliance: Telcordia GR-253-CORE, ITU-T G.707, ITU-T G.957
- Transmitter
 - Maximum transmitter output power:
 - +10 dBm (15454-OC192LR1550);
 - +7 dBm (15454-OC192-LR2)

- Minimum transmitter output power:
 - +7 dBm (15454-OC192LR1550);
 - +4 dBm (15454-OC192-LR2)
- Center wavelength: 1530 to 1565 nm
- Nominal wavelength: 1550 nm
- Maximum chromatic dispersion allowed: 1600 ps/nm
- Transmitter: LN (Lithium Niobate) external modulator transmitter
- Receiver
 - Maximum receiver level:
 - 10 dBm (15454-OC192LR1550);
 - 7 dBm (15454-OC192LR1550)
 - Minimum receiver level:
 - 19 dBm (15454-OC192LR1550);
 - 24 dBm from 1530 to 1565 nm
 - 20 dBm from 1290 to 1330 nm (15454-OC192-LR2)
 - Receiver: APD/TIA
 - Link loss budget: 24 dB minimum, with no dispersion or 22 dB optical path loss at BER = $1 - \exp(-12)$ including dispersion
 - Receiver input wavelength range: 1530 to 1565 nm
 - Jitter tolerance: Telcordia GR-253/ITU-T G.823 compliant
- Environmental
 - Operating temperature:
 - C-Temp (15454-OC192LR1550): +23 to +131 degrees Fahrenheit (-5 to +55 degrees Celsius)
 - Operating humidity: 5 to 95 percent, noncondensing
 - Power consumption: 72.20 W, 1.50 A, 246.52 BTU/hr (15454-OC192LR1550); 52.00 W, 1.08 A at -48 V, 177.6 BTU/hr (15454-OC192-LR2)
- Dimensions
 - Height: 12.650 in. (321.3 mm)
 - Width: 0.716 in. (18.2 mm)
 - Depth: 9.000 in. (228.6 mm)
 - Weight not including clam shell: 3.1 lb (1.3 kg)

A.6.16 OC192 LR/STM64 LH ITU 15xx.xx Card Specifications

The OC192 LR/STM64 LH ITU 15xx.xx card has the following specifications:

- Line
 - Bit rate: 9.95328 Gbps
 - Code: Scrambled NRZ
 - Fiber: 1550-nm single-mode
 - Maximum chromatic dispersion allowance:

In deployments with a dispersion compensation unit (DCU): +/- 1000 ps/nm, with optical signal-to-noise ration (OSNR) of 19 dB (0.5 nm resolution bandwidth [RBW])

In deployments without a DCU: +/- 1200 ps/nm, with OSNR of 23 dB (0.5 nm RBW)

- Loopback modes: Terminal and facility



Note You must use a 20-dB fiber attenuator (15 to 25 dB) when working with the OC192 LR/STM64 LH 15xx.xx card in a loopback. Do not use fiber loopbacks with the OC192 LR/STM64 LH 15xx.xx card. Using fiber loopbacks causes irreparable damage to this card.

- Connectors: SC
- Compliance: Telcordia GR-253-CORE, ITU-T G.707, ITU-T G.691, ITU-T G.957
- Transmitter
 - Maximum transmitter output power: +6 dBm
 - Minimum transmitter output power: +3 dBm
 - Center wavelength: See wavelength plan
 - Center wavelength accuracy: +/- 0.040 nm
 - Transmitter: LN external modulator transmitter
- Receiver
 - Maximum receiver level: -8 dBm at BER $1 * 10^{exp - 12}$
 - Minimum receiver level: -22 dBm at BER $1 * 10^{exp - 12}$
 - Receiver: APD
 - Link loss budget: 25 dB minimum, plus 2 dB dispersion penalty at BER = $1 * 10^{exp - 12}$ including dispersion
 - Receiver input wavelength range: 1529 to 1565 nm
- Environmental
 - Operating temperature: +23 to +131 degrees Fahrenheit (-5 to +55 degrees Celsius)
 - Operating humidity: 5 to 95 percent, noncondensing
 - Power consumption: 52.00 W, 1.08 A at -48 V, 177.6 BTU/hr
- Dimensions
 - Height: 12.650 in. (321.3 mm)
 - Width: 0.716 in. (18.2 mm)
 - Depth: 9.000 in. (228.6 mm)
 - Depth with backplane connector: 9.250 in. (235 mm)
 - Weight not including clam shell: 3.1 lb (1.3 kg)
- Currently available wavelengths and versions of OC192 LR/STM64 LH ITU 15xx.xx card:

ITU grid blue band:

 - 1534.25 +/- 0.040 nm, OC192 LR/STM64 LH ITU 1534.25
 - 1535.04 +/- 0.040 nm, OC192 LR/STM64 LH ITU 1535.04

- 1535.82 +/- 0.040 nm, OC192 LR/STM64 LH ITU 1535.82
- 1536.61 +/- 0.040 nm, OC192 LR/STM64 LH ITU 1536.61
- 1538.19 +/- 0.040 nm, OC192 LR/STM64 LH ITU 1538.19
- 1538.98 +/- 0.040 nm, OC192 LR/STM64 LH ITU 1538.98
- 1539.77 +/- 0.040 nm, OC192 LR/STM64 LH ITU 1539.77
- 1540.56 +/- 0.040 nm, OC192 LR/STM64 LH ITU 1540.56

ITU grid red band:

- 1550.12 +/- 0.040 nm, OC192 LR/STM64 LH ITU 1550.12
- 1550.92 +/- 0.040 nm, OC192 LR/STM64 LH ITU 1550.92
- 1551.72 +/- 0.040 nm, OC192 LR/STM64 LH ITU 1551.72
- 1552.52 +/- 0.040 nm, OC192 LR/STM64 LH ITU 1552.52
- 1554.13 +/- 0.040 nm, OC192 LR/STM64 LH ITU 1554.13
- 1554.94 +/- 0.040 nm, OC192 LR/STM64 LH ITU 1554.94
- 1555.75 +/- 0.040 nm, OC192 LR/STM64 LH ITU 1555.75
- 1556.55 +/- 0.040 nm, OC192 LR/STM64 LH ITU 1556.55

A.6.17 15454_MRC-12 Card Specifications

The 15454_MRC-12 card has the following specifications:

- Line
 - Bit rate: up to OC-48 (2488.320 Mbps), depending on SFP



Note Each optical interface on the card can be configured as OC-3, OC-12, or OC-48, depending on the available backplane bandwidth and existing provisioned lines. In general, the card supports all different rates on the line side as long as the accumulated bandwidth does not exceed the total backplane allowed bandwidth.

- Fiber: 1550-nm single-mode
- Connectors: LC duplex connector for each SFP
- Compliance: Telcordia GR-253-CORE
- Transmitter
 - Maximum transmitter output power: Depends on SFP (see [A.2 SFP, XFP, and GBIC Specifications, page A-4](#))
 - Minimum transmitter output power: Depends on SFP (see [A.2 SFP, XFP, and GBIC Specifications, page A-4](#))
 - Center wavelength: See wavelength plan
 - Center wavelength accuracy: 1 nm to 4 nm, depending on SFP
 - Transmitter: FP and DFB laser
- Receiver

- Maximum receiver level: Depends on SFP (see [A.2 SFP, XFP, and GBIC Specifications, page A-4](#))
- Minimum receiver level: Depends on SFP (see [A.2 SFP, XFP, and GBIC Specifications, page A-4](#))
- Receiver: PIN PD
- Receiver input wavelength range: Depends on SFP
- Environmental
 - Operating temperature: –40 to +149 degrees Fahrenheit (–40 to +65 degrees Celsius)
 - Operating humidity: 5 to 95 percent, noncondensing
 - Power consumption: 38.00 W, 0.79 A at –48 V, 129.66 BTU/hr
- Dimensions
 - Height: 12.650 in. (321.3 mm)
 - Width: 0.716 in. (18.2 mm)
 - Depth: 9.000 in. (228.6 mm)
 - Depth with backplane connector: 9.250 in. (235 mm)
 - Weight not including clam shell: 3.1 lb (1.3 kg)
- Wavelength plan. Currently available wavelengths and versions of the 15454_MRC-12 card:
 - For ONS-SC-2G-30.3 through ONS-SC-2G-60.0 SFPs: 1530.33 nm to 1560.61 nm (32 distinct wavelengths at 100 GHz spacing)
 - For ONS-SE-622-1470 through ONS-SE-622-1610 SFPs: 1470 to 1610 nm (eight distinct wavelengths at 2500 GHz spacing)
 - For ONS_SE-155-1470 through ONS-SE-155-1610 SFPs: 1470 to 1610 nm (eight distinct wavelengths at 2500 GHz spacing)

A.6.18 OC192SR1/STM64IO Short Reach Card Specifications



Note

The OC192SR1/STM64IO Short Reach card is designated as OC192-XFP in CTC.

The OC192SR1/STM64IO Short Reach card has the following specifications:

- Line
 - Bit rate: OC-192 (9.9520 Gbps)
 - Fiber: 1310-nm single-mode
 - Connectors: LC duplex connector for the XFP
 - Compliance: Telcordia GR-253-CORE
- Transmitter
 - Maximum transmitter output power: –1 dBm
 - Minimum transmitter output power: –6 dBm
- Receiver
 - Maximum receiver level: –1 dBm

- Minimum receiver level: -11 dBm
- Receiver input wavelength range: 1260 to 1565 nm
- Environmental
 - Operating temperature: 32 to +131 degrees Fahrenheit (0 to +55 degrees Celsius)
 - Operating humidity: 5 to 95 percent, noncondensing
 - Power consumption: 40.00 W, 0.83 A at -48 V, 136.49 BTU/hr
- Dimensions
 - Height: 12.650 in. (321.3 mm)
 - Width: 0.716 in. (18.2 mm)
 - Depth: 9.000 in. (228.6 mm)
 - Depth with backplane connector: 9.250 in. (235 mm)
 - Weight not including clam shell: 3.1 lb (1.3 kg)

A.6.19 OC192/STM64 Any Reach Card Specifications



Note

The OC192/STM64 Any Reach card is designated as OC192-XFP in CTC.

The OC192/STM64 Any Reach card has the following specifications:

- Line
 - Bit rate: OC-192 (9.9520 Gbps)
 - Fiber: 1310-nm single-mode for ONS-XC-10G-S1 XFP, 1550-nm single mode for ONS-XC-10G-I2 and ONS-XC-10G-L2 XFPs
 - Connectors: LC duplex connector for the XFPs
 - Compliance: Telcordia GR-253-CORE
- Transmitter
 - Maximum transmitter output power: Depends on SFP (see [A.2 SFP, XFP, and GBIC Specifications, page A-4](#))
 - Minimum transmitter output power: Depends on SFP (see [A.2 SFP, XFP, and GBIC Specifications, page A-4](#))
- Receiver
 - Maximum receiver level: Depends on SFP (see [A.2 SFP, XFP, and GBIC Specifications, page A-4](#))
 - Minimum receiver level: Depends on SFP (see [A.2 SFP, XFP, and GBIC Specifications, page A-4](#))
 - Receiver input wavelength range: 1260 to 1565 nm
- Environmental
 - Operating temperature: 32 to +131 degrees Fahrenheit (0 to +55 degrees Celsius)
 - Operating humidity: 5 to 95 percent, noncondensing
 - Power consumption: 40.00 W, 0.83 A at -48 V, 136.49 BTU/hr

- Dimensions
 - Height: 12.650 in. (321.3 mm)
 - Width: 0.716 in. (18.2 mm)
 - Depth: 9.000 in. (228.6 mm)
 - Depth with backplane connector: 9.250 in. (235 mm)
 - Weight not including clam shell: 3.1 lb (1.3 kg)

A.7 Ethernet Card Specifications

This section includes specifications for the E100T-12, E100T-G, E1000-2, E1000-2-G, CE-1000-4, CE-100T-8, G1K-4, ML100T-12, ML1000-2, and ML100X-8 cards.

For compliance information, refer to the *Cisco Optical Transport Products Safety and Compliance Information* document.

A.7.1 E100T-12 Card Specifications

The E100T-12 card has the following specifications:

- Environmental
 - Operating temperature
 - C-Temp (15454-E100T): 32 to 131 degrees Fahrenheit (0 to +55 degrees Celsius)
 - Operating humidity: 5 to 95 percent, noncondensing
 - Power consumption: 65 W, 1.35 A, 221.93 BTU/hr
- Dimensions
 - Height: 12.650 in. (321.3 mm)
 - Width: 0.716 in. (18.2 mm)
 - Depth: 9.000 in. (228.6 mm)
 - Card weight: 2.3 lb (1.0 kg)

A.7.2 E100T-G Card Specifications

The E100T-G card has the following specifications:

- Environmental
 - Operating temperature:
 - C-Temp (15454-E100T-G): 32 to 131 degrees Fahrenheit (0 to +55 degrees Celsius)
 - Operating humidity: 5 to 95 percent, noncondensing
 - Power consumption: 65 W, 1.35 A, 221.93 BTU/hr
- Dimensions
 - Height: 12.650 in. (321.3 mm)
 - Width: 0.716 in. (18.2 mm)

- Depth: 9.000 in. (228.6 mm)
- Card weight: 2.3 lb (1.0 kg)

A.7.3 E1000-2 Card Specifications

The E1000-2 card has the following specifications:

- Environmental
 - Operating temperature:
C-Temp (15454-E1000-2): 32 to 131 degrees Fahrenheit (0 to +55 degrees Celsius)
 - Operating humidity: 5 to 95 percent, noncondensing
 - Power consumption: 53.50 W, 1.11 A, 182.67 BTU/hr
- Dimensions
 - Height: 12.650 in. (321.3 mm)
 - Width: 0.716 in. (18.2 mm)
 - Depth: 9.000 in. (228.6 mm)
 - Card weight: 2.1 lb (0.9 kg)

A.7.4 E1000-2-G Card Specifications

The E1000-2-G card has the following specifications:

- Environmental
 - Operating temperature:
C-Temp (15454-E1000-2-G): 32 to 131 degrees Fahrenheit (0 to +55 degrees Celsius)
 - Operating humidity: 5 to 95 percent, noncondensing
 - Power consumption: 53.50 W, 1.11 A, 182.67 BTU/hr
- Dimensions
 - Height: 12.650 in. (321.3 mm)
 - Width: 0.716 in. (18.2 mm)
 - Depth: 9.000 in. (228.6 mm)
 - Card weight: 2.1 lb (0.9 kg)

A.7.5 CE-1000-4 Card Specifications

The CE-1000-4 card has the following specifications:

- Environmental
 - Operating temperature: +23 to +131 degrees Fahrenheit (-5 to +55 degrees Celsius)
 - Operating humidity: 5 to 95 percent, noncondensing
 - Power consumption: 60 W, 1.25 A at -48 V, 204.8 BTU/hr

- Dimensions
 - Height: 12.650 in. (321.310 mm)
 - Width: 0.716 in. (18.2 mm)
 - Depth: 9.000 in. (228.6 mm)
 - Card weight: 2.1 lb (0.9 kg)

A.7.6 CE-100T-8 Card Specifications

The CE-100T-8 card has the following specifications:

- Environmental
 - Operating temperature
 - C-Temp (15454-CE100T): 32 to 131 degrees Fahrenheit (0 to +55 degrees Celsius)
 - Operating humidity: 0 to 95 percent, noncondensing
 - Power consumption: 53 W, 1.1 A, 181.3 BTU/hr
- Dimensions
 - Height: 12.650 in. (321.3 mm)
 - Width: 0.913 in. (23.19 mm)
 - Depth: 9.073 in. (230.45 mm)
 - Card weight: 1.8 lb (0.82 kg)

A.7.7 G1K-4 Card Specifications

The G1K-4 card has the following specifications:

- Environmental
 - Operating temperature: +23 to +131 degrees Fahrenheit (–5 to +55 degrees Celsius)
 - Operating humidity: 5 to 95 percent, noncondensing
 - Power consumption: 63.00 W, 1.31 A at –48 V, 215.1 BTU/hr
- Dimensions
 - Height: 12.650 in. (321.3 mm)
 - Width: 0.716 in. (18.2 mm)
 - Depth: 9.000 in. (228.6 mm)
 - Depth with backplane connector: 9.250 in. (235 mm)
 - Weight not including clam shell: 2.1 lb (0.9 kg)

A.7.8 ML100T-12 Card Specifications

The ML100T-12 card has the following specifications:

- Environmental

- Operating temperature: +23 to +131 degrees Fahrenheit (-5 to +55 degrees Celsius)
- Operating humidity: 5 to 95 percent, noncondensing
- Power consumption: 53.00 W, 1.10 A at -48 V, 181.0 BTU/hr
- Dimensions
 - Height: 12.650 in. (321.3 mm)
 - Width: 0.716 in. (18.2 mm)
 - Depth: 9.000 in. (228.6 mm)
 - Depth with backplane connector: 9.250 in. (235 mm)
 - Weight not including clam shell: 2.3 lb (1.0 kg)

A.7.9 ML1000-2 Card Specifications

The ML1000-2 card has the following specifications:

- Environmental
 - Operating temperature: +23 to +131 degrees Fahrenheit (-5 to +55 degrees Celsius)
 - Operating humidity: 5 to 95 percent, noncondensing
 - Power consumption: 49.00 W, 1.02 A at -48 V, 167.3 BTU/hr
- Dimensions
 - Height: 12.650 in. (321.3 mm)
 - Width: 0.716 in. (18.2 mm)
 - Depth: 9.000 in. (228.6 mm)
 - Depth with backplane connector: 9.250 in. (235 mm)
 - Weight not including clam shell: 0.9 kg (2.1 lb)

A.7.10 ML100X-8 Card Specifications

The ML100X-8 card has the following specifications:

- Environmental
 - Operating temperature: +23 to +131 degrees Fahrenheit (-5 to +55 degrees Celsius)
 - Operating humidity: 5 to 95 percent, noncondensing
 - Power consumption: 65.00 W, 1.35 A at -48 V, 221.93 BTU/hr
- Dimensions
 - Height: 12.650 in. (321.3 mm)
 - Width: 0.716 in. (18.2 mm)
 - Depth: 9.000 in. (228.6 mm)
 - Depth with backplane connector: 9.250 in. (235 mm)
 - Weight not including clam shell: 0.9 kg (2.1 lb)

A.8 Storage Access Networking Card Specifications

This section describes the FC_MR-4 (Fibre Channel) card specifications.

For compliance information, refer to the *Cisco Optical Transport Products Safety and Compliance Information* document.

A.8.1 FC_MR-4 Card Specifications

The FC_MR-4 card has the following specifications:

- Fibre Channel Support: FC-0 and FC-1 layers of ANSI X3.230 FC-PH
- GBIC Line Interface
 - Bit Rate: 1.0625 Gbit/s single-rate or 1.0625/2.125 dual-rate Gbit/s Fibre Channel (FC)
 - Wavelength/Fiber/Reach:
 - 850 nm, multimode fiber, 550 m (SX)
 - 1310 nm, single-mode fiber, 10 km (LX)
 - 1550 nm/, single-mode fiber, 80 km (ZX)
 - Hot pluggable
 - Auto-detection
- Transmitter
 - Maximum transmitter output power: depends on GBIC type (see [Table A-1](#))
 - Minimum transmitter output power: depends on GBIC type (see [Table A-1](#))
- Receiver
 - Maximum receiver level: depends on GBIC type (see [Table A-1](#))
 - Minimum receiver level: depends on GBIC type (see [Table A-1](#))
- Environmental
 - Operating temperature
 - C-Temp (15454-E100T): 23 to 131 degrees Fahrenheit (–5 to +55 degrees Celsius)
 - Operating humidity: 5 to 95 percent, noncondensing
 - Power consumption: 60 W, 1.35 A, 221.93 BTU/hr
- Dimensions
 - Height: 12.650 in. (321.3 mm)
 - Width: 0.716 in. (18.2 mm)
 - Depth: 9.000 in. (228.6 mm)
 - Card weight: 2.59 lb (1.17 kg)



APPENDIX **B**

Administrative and Service States

This appendix describes administrative and service states for Cisco ONS 15454 cards, ports, and cross-connects. For circuit state information, refer to [Chapter 11, “Circuits and Tunnels.”](#) Entity states in Software Release 5.0 and later are based on the generic state model defined in Telcordia GR-1093-CORE, Issue 2 and ITU-T X.731.

B.1 Service States

Service states include a Primary State (PST), a Primary State Qualifier (PSTQ), and one or more Secondary States (SST). [Table B-1](#) lists the service state PSTs and PSTQs supported by the ONS 15454.

Table B-1 *ONS 15454 Service State Primary States and Primary State Qualifiers*

Primary State, Primary State Qualifier	Definition
IS-NR	(In-Service and Normal) The entity is fully operational and will perform as provisioned.
OOS-AU	(Out-of-Service and Autonomous) The entity is not operational because of an autonomous event.
OOS-AUMA	(Out-of-Service and Autonomous Management) The entity is not operational because of an autonomous event and has also been manually removed from service.
OOS-MA	(Out-of-Service and Management) The entity has been manually removed from service.

[Table B-2](#) defines the SSTs supported by the ONS 15454.

Table B-2 ONS 15454 Secondary States

Secondary State	Definition
AINS	(Automatic In-Service) The entity is delayed before transitioning to the IS-NR service state. The transition to IS-NR depends on the correction of conditions, or on a soak timer. Alarm reporting is suppressed, but traffic is carried. Raised fault conditions, whether or not their alarms are reported, can be retrieved on the CTC Conditions tab or by using the TL1 RTRV-COND command.
DSBLD	(Disabled) The entity was manually removed from service and does not provide its provisioned functions. All services are disrupted; the entity is unable to carry traffic. Note OC-N ports and connections in the DSBLD state continue to send an Alarm Indication Signal Line (AIS-L).
FLT	(Fault) The entity has a raised alarm or condition.
LPBK	(Loopback) The entity is in loopback mode.
MEA	(Mismatched Equipment) An improper card is installed. For example, an installed card is not compatible with the card preprovisioning or the slot. This SST applies only to cards.
MT	(Maintenance) The entity has been manually removed from service for a maintenance activity but still performs its provisioned functions. Alarm reporting is suppressed, but traffic is carried. Raised fault conditions, whether or not their alarms are reported, can be retrieved on the CTC Conditions tab or by using the TL1 RTRV-COND command.
OOG	(Out of Group) The virtual concatenation (VCAT) member cross-connect is not used to carry VCAT group traffic. This state is used to put a member circuit out of the group and to stop sending traffic. OOS-MA,OOG only applies to the cross-connects on an end node where VCAT resides. The cross-connects on intermediate nodes are in the OOS-MA,MT service state.
SWDL	(Software Download) The card is involved in a software and database download. This SST applies only to cards.
UAS	(Unassigned) The card is not provisioned in the database. This SST applies only to cards.
UEQ	(Unequipped) The card is not physically present (that is, an empty slot). This SST applies only to cards.

B.2 Administrative States

Administrative states are used to manage service states. Administrative states consist of a PST and an SST. [Table B-3](#) lists the administrative states supported by the ONS 15454. See [Table B-2](#) for SST definitions.



Note

A change in the administrative state of an entity does not change the service state of supporting or supported entities.

Table B-3 ONS 15454 Administrative States

Administrative State (PST,SST)	Definition
IS	Puts the entity in service.
IS,AINS	Puts the entity in automatic in-service.
OOS,DSBLD	Removes the entity from service and disables it.
OOS,MT	Removes the entity from service for maintenance.
OOS,OOG	(VCAT circuits only) Removes a VCAT cross-connect cross-connect from service and from the group of members. Note Only CE-100T-8 cards in link capacity adjustment scheme (LCAS) mode and FC_MR-4 (enhanced mode) cards in software LCAS (SW-LCAS) mode accept the OOG state.

B.3 Service State Transitions

This section describes the transition from one service state to the next for cards, ports, and cross-connects. A service state transition is based on the action performed on the entity.



Note

When an entity is put in the OOS,MT administrative state, the ONS 15454 suppresses all standing alarms on that entity. All alarms and events appear on the Conditions tab. You can change this behavior for the LPBKFACILITY and LPBKTERMINAL alarms. To display these alarms on the Alarms tab, set the NODE.general.ReportLoopbackConditionsOnOOS-MTPorts to TRUE on the NE Defaults tab.

B.3.1 Card Service State Transitions

Table B-4 lists card service state transitions.

Table B-4 ONS 15454 Card Service State Transitions

Current Service State	Action	Next Service State
IS-NR	Change the administrative state to OOS,MT.	OOS-MA,MT
	Delete the card.	OOS-AUMA,UAS
	Remove the card.	OOS-AU,UEQ
	Reset the card.	OOS-AU,SWDL
	Alarm/condition is raised.	OOS-AU,FLT
OOS-AU,AINS & MEA	Remove the card.	OOS-AU,AINS & UEQ
	Delete the card.	OOS-AUMA,UAS if the card is valid OOS-AUMA,MEA & UAS if the card is invalid

Table B-4 ONS 15454 Card Service State Transitions (continued)

Current Service State	Action	Next Service State
OOS-AU,AINS & SWDL	Restart completed.	IS-NR
	Remove the card.	OOS-AU,AINS & UEQ
OOS-AU,AINS & UEQ	Insert a valid card.	OOS-AU,AINS & SWDL
	Insert an invalid card.	OOS-AU,AINS & MEA
	Delete the card.	OOS-AUMA,UAS & UEQ
OOS-AU,FLT	Remove the card.	OOS-AU,UEQ
	Delete the card.	OOS-AUMA,UAS
	Change the administrative state to OOS,MT.	OOS-AUMA,FLT & MT
	Reset the card.	OOS-AU,SWDL
	Alarm/condition is cleared.	IS-NR
OOS-AU,MEA	Remove the card.	OOS-AU,UEQ
	Delete the card.	OOS-AUMA,UAS if the card is valid OOS-AUMA,MEA & UAS if the card is invalid
	Change the administrative state to OOS,MT.	OOS-AUMA,MEA & MT
OOS-AU,SWDL	Restart completed.	IS-NR
	Remove the card.	OOS-AU,UEQ
OOS-AU,UEQ	Insert a valid card.	OOS-AU,SWDL
	Insert an invalid card.	OOS-AU,MEA
	Delete the card.	OOS-AUMA,UAS & UEQ
	Change the administrative state to OOS,MT.	OOS-AUMA,MT & UEQ
OOS-AUMA,FLT & MT	Remove the card.	OOS-AUMA,MT & UEQ
	Delete the card.	OOS-AUMA,UAS
	Change the administrative state to IS.	OOS-AU,FLT
	Reset the card.	OOS-AUMA,MT & SWDL
	Alarm/condition is cleared.	OOS-MA,MT
OOS-AUMA,MEA & MT	Change the administrative state to IS.	OOS-AU,MEA
	Remove the card.	OOS-AUMA,MT & UEQ
	Delete the card.	OOS-AUMA,UAS if the card is valid OOS-AUMA,MEA & UAS if the card is invalid

Table B-4 ONS 15454 Card Service State Transitions (continued)

Current Service State	Action	Next Service State
OOS-AUMA,MEA & UAS	Remove the card.	OOS-AUMA,UAS & UEQ
	Provision the card.	OOS-AU,MEA
OOS-AUMA,MT & SWDL	Restart completed.	OOS-MA,MT
	Remove the card.	OOS-AUMA,MT & UEQ
OOS-AUMA,MT & UEQ	Change the administrative state to IS.	OOS-AU,UEQ
	Insert a valid card.	OOS-AUMA,MT & SWDL
	Insert an invalid card.	OOS-AUMA,MEA & MT
	Delete the card.	OOS-AUMA,UAS & UEQ
OOS-AUMA,UAS	Remove the card.	OOS-AUMA,UAS & UEQ
	Provision an invalid card.	OOS-AU,MEA
	Provision a valid card.	OOS-AU,SWDL
OOS-AUMA,UAS & UEQ	Insert a valid card.	OOS-AU,SWDL
	Insert an invalid card.	OOS-AUMA,MEA & UAS
	Preprovision a card.	OOS-AU,AINS & UEQ
OOS-MA,MT	Change the administrative state to IS.	IS-NR
	Delete the card.	OOS-AUMA,UAS
	Remove the card.	OOS-AUMA,MT & UEQ
	Reset the card.	OOS-AUMA,MT & SWDL
	Alarm/condition is raised.	OOS-AUMA,FLT & MT

B.3.2 Port and Cross-Connect Service State Transitions

Table B-5 lists the port and cross-connect service state transitions. Port states do not impact cross-connect states with one exception. A cross-connect in the OOS-AU,AINS service state cannot transition autonomously into the IS-NR service state until the parent port is IS-NR.

The following ports do not support all of the service states listed in Table B-5:

- E-Series Ethernet ports do not support service states; these ports are either enabled or disabled.
- FC_MR-4 ports support the IS-NR; OOS-MA,DSBLD; and OOS-MA,MT service states; they do not support the OOS-AU,AINS service state.



Note

Deleting a port or cross-connect removes the entity from the system. The deleted entity does not transition to another service state.



Note

The DS1 port service state on the DS3XM-12 card is based on the DS3 service state.

Table B-5 ONS 15454 Port and Cross-Connect Service State Transitions

Current Service State	Action	Next Service State
IS-NR	Put the port or cross-connect in the OOS,MT administrative state.	OOS-MA,MT
	Put the port or cross-connect in the OOS,DSBLD administrative state.	OOS-MA,DSBLD OOS-MA,DSBLD & OOG for a VCAT cross-connect
	Put the port or cross-connect in the IS,AINS administrative state.	OOS-AU,AINS ¹
	Put the VCAT cross-connect in the OOS,OOG administrative state.	OOS-MA,MT & OOG
	Alarm/condition is raised.	OOS-AU,FLT OOS-AU,FLT & OOG for a VCAT cross-connect
OOS-AU,AINS	Put the port or cross-connect in the IS administrative state.	IS-NR
	Put the port or cross-connect in the OOS,MT administrative state.	OOS-MA,MT
	Put the port or cross-connect in the OOS,DSBLD administrative state.	OOS-MA,DSBLD OOS-MA,DSBLD & OOG for a VCAT cross-connect
	Put the VCAT cross-connect in the OOS,OOG administrative state.	OOS-MA,MT and OOG
	Alarm/condition is raised.	OOS-AU,AINS & FLT OOS-AU,AINS & FLT & OOG for a VCAT cross-connect
OOS-AU,AINS & FLT	Alarm/condition is cleared.	OOS-AU,AINS
	Put the port or cross-connect in the IS administrative state.	OOS-AU,FLT
	Put the port or cross-connect in the OOS,DSBLD administrative state.	OOS-MA,DSBLD
	Put the port or cross-connect in the OOS,MT administrative state.	OOS-AUMA,FLT & MT
	Put the VCAT cross-connect in the OOS,OOG administrative state.	OOS-AUMA,FLT & MT & OOG

Table B-5 ONS 15454 Port and Cross-Connect Service State Transitions (continued)

Current Service State	Action	Next Service State
OOS-AU,AINS & FLT & OOG	Alarm/condition is cleared.	OOS-AU,AINS or OOS-MA,MT <ul style="list-style-type: none"> If an In Group member is IS-NR or OOS-AU,AINS, the member transitions to OOS-AU,AINS If an In Group member is OOS-MA,MT, the member transitions to OOS-MA,MT
	Put the VCAT cross-connect in the IS administrative state.	OOS-AU,FLT & OOG
	Put the VCAT cross-connect in the OOS,DSBLD administrative state.	OOS-MA,DSBLD & OOG
	Put the VCAT cross-connect in the OOS,MT administrative state.	OOS-AUMA,FLT & MT & OOG
OOS-AU,FLT	Alarm/condition is cleared.	IS-NR
	Put the port or cross-connect in the IS,AINS administrative state.	OOS-AU,AINS & FLT
	Put the port or cross-connect in the OOS,DSBLD administrative state.	OOS-MA,DSBLD OOS-MA,DSBLD & OOG for a VCAT cross-connect
	Put the port or cross-connect in the OOS,MT administrative state	OOS-AUMA,FLT & MT
	Put the VCAT cross-connect in the OOS,OOG administrative state.	OOS-AUMA,FLT & MT & OOG
OOS-AU,FLT & OOG	Alarm/condition is cleared.	IS-NR or OOS-MA,MT <ul style="list-style-type: none"> If an In Group member is IS-NR or OOS-AU,AINS, the member transitions to IS-NR. If an In Group member is OOS-MA,MT, the member transitions to OOS-MA,MT
	Put the VCAT cross-connect in the IS,AINS administrative state.	OOS-AU,AINS & FLT & OOG
	Put the VCAT cross-connect in the OOS,DSBLD administrative state.	OOS-MA,DSBLD & OOG
	Put the VCAT cross-connect in the OOS,MT administrative state.	OOS-AUMA,FLT & MT & OOG
OOS-AUMA,FLT & LPBK & MT	Release the loopback.	OOS-AUMA,FLT & MT
	Alarm/condition is cleared.	OOS-MA,LPBK & MT

Table B-5 ONS 15454 Port and Cross-Connect Service State Transitions (continued)

Current Service State	Action	Next Service State
OOS-AUMA,FLT & LPBK & MT & OOG	Release the loopback.	OOS-AUMA,FLT & MT & OOG
	Alarm/condition is cleared.	OOS-MT,MT & OOG
OOS-AUMA,FLT & MT	Alarm/condition is cleared.	OOS-MA,MT
	Put the port or cross-connect in the IS administrative state.	OOS-AU,FLT
	Put the port or cross-connect in the IS,AINS administrative state.	OOS-AU,AINS & FLT
	Put the port or cross-connect in the OOS,DSBLD administrative state.	OOS-MA,DSBLD OOS-MA,DSBLD & OOG for a VCAT cross-connect
	Put the port or cross-connect in a loopback.	OOS-AUMA,FLT & LPBK & MT
	Put the VCAT cross-connect in the OOS,OOG administrative state.	OOS-AUMA,FLT & MT & OOG
OOS-AUMA,FLT & MT & OOG	Alarm/condition is cleared.	OOS-MA,MT & OOG
	Put the VCAT cross-connect in the IS administrative state.	OOS-AU,FLT & OOG
	Note VCAT In Group members are in the OOS-AU,FLT or IS-NR service state.	
	Put the VCAT cross-connect in the IS,AINS administrative state.	OOS-AU,AINS & FLT & OOG
	Note VCAT In Group members are in the OOS-AU,AINS & FLT or IS-NR service state.	
	Put the VCAT cross-connect in the OOS,DSBLD administrative state.	OOS-MA,DSBLD & OOG
	Put the VCAT cross-connect in the OOS,MT administrative state.	OOS-MA,FLT & MT
Note VCAT In Group members are in the OOS-MA,FLT & MT service state.		
	Operate a loopback.	OOS-MA,FLT & LPBK & MT & OOG

Table B-5 ONS 15454 Port and Cross-Connect Service State Transitions (continued)

Current Service State	Action	Next Service State
OOS-MA,DSBLD	Put the port or cross-connect in the IS administrative state.	IS-NR
	Put the port or cross-connect in the IS,AINS administrative state.	OOS-AU,AINS
	Put the port or cross-connect in the OOS,MT administrative state.	OOS-MA,MT
	Put the VCAT cross-connect in the OOS,OOG administrative state.	OOS-MA,MT & OOG
OOS-MA,LPBK & MT	Release the loopback. Note While in OOS-MA,LPBK & MT, both Cisco Transport Controller (CTC) and Transaction Language One (TL1) allow a cross-connect to be deleted, which also removes the loopback. This applies only to the cross-connect, not the ports.	OOS-MA,MT
	Alarm/condition is raised.	OOS-AUMA,FLT & LPBK & MT OOS-AUMA,FLT & LPBK & MT & OOG for a VCAT cross-connect
OOS-MA,LPBK & MT & OOG	Alarm/condition is raised.	OOS-AUMA,FLT & LPBK & MT & OOG
OOS-MA,MT	Put the port or cross-connect in the IS administrative state.	IS-NR
	Put the port or cross-connect in the IS,AINS administrative state.	OOS-AU,AINS
	Put the port or cross-connect in the OOS,DSBLD administrative state.	OOS-MA,DSBLD OOS-MA,DSBLD & OOG for a VCAT cross-connect
	Put the port or cross-connect in a loopback.	OOS-MA,LPBK & MT
	Put the VCAT cross-connect in the OOS,OOG administrative state.	OOS-MA,MT & OOG
	Alarm/condition is raised.	OOS-AUMA,FLT & MT OOS-AUMA,FLT & MT & OOG for a VCAT cross-connect
OOG-MA,MT & OOG	Alarm/condition is raised.	OOS-AUMA,FLT & MT & OOG

- For a VCAT cross-connect, an IS-NR to OOS-AU,AINS transition will not occur with a Loss of Multiframe (LOM) or Sequence Mismatch (SQM) condition on the member.



APPENDIX **C**

Network Element Defaults



Note

The terms "Unidirectional Path Switched Ring" and "UPSR" may appear in Cisco literature. These terms do not refer to using Cisco ONS 15xxx products in a unidirectional path switched ring configuration. Rather, these terms, as well as "Path Protected Mesh Network" and "PPMN," refer generally to Cisco's path protection feature, which may be used in any topological network configuration. Cisco does not recommend using its path protection feature in any particular topological network configuration.

This appendix describes the factory-configured (default) network element (NE) settings for the Cisco ONS 15454. It includes descriptions of card, node, and Cisco Transport Controller (CTC) default settings. To import, export, or edit the settings, refer to the "Maintain the Node" chapter of the *Cisco ONS 15454 Procedure Guide*. Cards supported by this platform that are not listed in this appendix are not supported by user-configurable NE defaults settings.

To change card settings individually (that is, without directly changing the NE defaults), refer to the "Change Card Settings" chapter of the *Cisco ONS 15454 Procedure Guide*. To change node settings, refer to the "Change Node Settings" chapter of the *Cisco ONS 15454 Procedure Guide*.

This appendix includes the following sections:

- [C.1 Network Element Defaults Description, page C-1](#)
- [C.2 Card Default Settings, page C-2](#)
- [C.3 Node Default Settings, page C-74](#)
- [C.4 CTC Default Settings, page C-86](#)

C.1 Network Element Defaults Description

The NE defaults are preinstalled on each Cisco ONS 15454 Advanced Timing, Communications, and Control (TCC2) and Advanced Timing, Communications, and Control Plus (TCC2P) card. They also ship as a file called 15454-defaults.txt on the CTC software CD in case you want to import the defaults onto existing TCC2/TCC2P cards. The NE defaults include card-level, CTC, and node-level defaults.

Changes to card provisioning that are made manually using the "Change Card Settings" chapter in the *Cisco ONS 15454 Procedure Guide* override default settings. If you use the CTC Defaults editor (in the node view Provisioning > Defaults tab) or import a new defaults file, any changes to card or port settings that result only affect cards that are installed or reprovisioned after the defaults have changed.

Changes that are made manually to most node-level default settings override the current settings, whether default or provisioned. If you change node-level default settings, either by using the Defaults editor or by importing a new defaults file, the new defaults reprovision the node immediately for all

settings except those relating to protection (1+1 bidirectional switching, 1+1 reversion time, 1+1 revertive switching, bidirectional line switched ring [BLSR] ring reversion time, BLSR ring revertive switching, BLSR span reversion time, and BLSR span revertive switching), which apply to subsequent provisioning.



Note Changing some node-level provisioning via NE defaults can cause CTC disconnection or a reboot of the node in order for the provisioning to take effect. Before you change a default, check in the Side Effects column of the Defaults editor (right-click a column header and select **Show Column > Side Effects**) and be prepared for the occurrence of any side effects listed for that default.

C.2 Card Default Settings

The tables in this section list the default settings for each SONET card. Cisco provides several types of user-configurable defaults for Cisco ONS 15454 optical, electrical, storage access networking, and Ethernet (or data) cards. Types of card defaults can be broadly grouped by function, as outlined in the following subsections. For information about individual card settings, refer to the “Change Card Settings” chapter of the *Cisco ONS 15454 Procedure Guide*.



Note When the card level defaults are changed, the new provisioning done after the defaults have changed is affected. Existing provisioning remains unaffected.



Note To view DWDM card defaults consult the *Cisco ONS 15454 DWDM Reference Manual*.

The following types of defaults are defined for SONET cards.

C.2.1 Configuration Defaults

Most card and port-level configuration defaults correspond to settings found in the CTC card-level Provisioning tabs.



Note The full set of Automatic Laser Shutdown (ALS) configuration defaults can be found in the CTC card-level Maintenance > ALS tab for supported cards. ALS defaults are supported for OC3-8, OC-48ELR, OC-192, OC192-XFP, and MRC-12 cards.

Configuration defaults that correspond to settings that are reachable from the CTC card-level Provisioning tabs (except as noted) include the following types of options (arranged by CTC subtab):

- Line—(DS-N, EC1-12, OC-N, MRC-12, G-series, and CE-series cards) Line-level configuration settings.



Note MRC-12 line configuration defaults are defined on a per OC-N rate basis.

- SONET STS—(OC-N and EC1-12 cards) SONET STS-level configuration settings.

- Port—(FC_MR-4 cards only) Port line-level configuration, distance extension, and enhanced FC/FICON ISL settings.
- Card—(DS1/E1-56, ML-series, and FC_MR-4 cards) Transport mode, operating mode, enable/disable retiming, and port to Virtual Tributary (VT) mapping standard settings (DS1/E1-56 only); or FC_MR-4 card mode settings (FC_MR-4 only); or framing mode (ML-series cards).
- DS1—(DS3XM-12 cards only) DS-1 rate virtual port-level line configuration settings.
- Broadband Ports—(DS3/EC1-48 cards only) Set the port rate as DS3, EC1, or unassigned (DS3 is the default).
- DS3—(DS3/EC1-48 cards only) DS-3 rate port-level line configuration settings.
- EC1—(DS3/EC1-48 cards only) EC-1 rate port-level line configuration, section trace, and SONET STS settings.
- ALS (card-level Maintenance > ALS tab)—(OC3-8, OC-48ELR, OC-192, OC192-XFP, and MRC-12 cards) ALS configuration defaults.
- IOS (card-level IOS tab)—(ML-series cards) Console port and RADIUS server access settings.
- Ether Ports—(CE-series cards) Line configuration settings (including 802 class of service [IEEE 802.1p CoS] and IP type of service [ToS]).
- POS Ports—(CE-series cards) Line configuration settings.

**Note**

Line configuration defaults for the CE-100T-8 card apply to both Ethernet port and packet-over-SONET (POS) port settings where the same setting exists for both.

**Note**

For further information about each card, consult the appropriate card reference chapter, that is, [Chapter 3, “Electrical Cards,”](#) [Chapter 4, “Optical Cards,”](#) [Chapter 5, “Ethernet Cards,”](#) and [Chapter 6, “Storage Access Networking Cards.”](#)

**Note**

For further information about IOS configuration defaults for ML-series cards, refer to the *Ethernet Card Software Feature and Configuration Guide for the Cisco ONS 15454, Cisco ONS 15454 SDH, and Cisco ONS 15327*.

C.2.2 Threshold Defaults

Threshold default settings define the default cumulative values (thresholds) beyond which a threshold crossing alert (TCA) will be raised, making it possible to monitor the network and detect errors early.

Card threshold default settings are provided as follows:

- PM thresholds—(DS-N, EC-1, OC-N, and MRC-12 cards) Can be expressed in counts or seconds; includes line, electrical path, and SONET thresholds.
- Physical Layer thresholds—(OC3-8, OC-192, OC-192XFP, and MRC-12 cards) Expressed in percentages; includes optics thresholds.

Threshold defaults are defined for near end and/or far end, at 15-minute and one-day intervals. Thresholds are further broken down by type, such as Section, Line, STS, or VT for performance monitoring (PM) thresholds, and TCA (warning) or Alarm for physical thresholds. PM threshold types define the layer to which the threshold applies. Physical threshold types define the level of response expected when the threshold is crossed.



Note For full descriptions of the thresholds you can set for each card, see [Chapter 15, “Performance Monitoring.”](#)



Note For additional information regarding PM parameter threshold defaults as defined by Telcordia specifications, refer to Telcordia GR-820-CORE and GR-253-CORE.

C.2.3 Defaults by Card

In the tables that follow, card defaults are defined by the default name, its factory-configured value, and the domain of allowable values that you can assign to it.



Note Some default values, such as certain thresholds, are interdependent. Before changing a value, review the domain for that default and any other related defaults for potential dependencies.

C.2.3.1 DS-1 Card Default Settings

[Table C-1](#) lists the DS-1 (DS1-14 and DS1N-14) card default settings.

Table C-1 DS-1 Card Default Settings

Default Name	Default Value	Default Domain
DS1.config.AINSSoakTime	08:00 (hours:mins)	00:00, 00:15, 00:30 .. 48:00
DS1.config.LineCoding	AMI	B8ZS, AMI
DS1.config.LineLength	0 - 131 ft	0 - 131 ft, 132 - 262 ft, 263 - 393 ft, 394 - 524 ft, 525 - 655 ft
DS1.config.LineType	D4	ESF, D4, UNFRAMED
DS1.config.SDBER	1E-7	1E-5, 1E-6, 1E-7, 1E-8, 1E-9
DS1.config.SFBER	1E-4	1E-3, 1E-4, 1E-5
DS1.config.State	IS,AINS	IS, OOS,DSBLD, OOS,MT, IS,AINS
DS1.pmthresholds.line.farend.15min.ES	65 (seconds)	0 - 900
DS1.pmthresholds.line.farend.1day.ES	648 (seconds)	0 - 86400
DS1.pmthresholds.line.nearend.15min.CV	13340 (BPV count)	0 - 1388700
DS1.pmthresholds.line.nearend.15min.ES	65 (seconds)	0 - 900
DS1.pmthresholds.line.nearend.15min.LOSS	10 (seconds)	0 - 900
DS1.pmthresholds.line.nearend.15min.SES	10 (seconds)	0 - 900

Table C-1 DS-1 Card Default Settings (continued)

Default Name	Default Value	Default Domain
DS1.pmthresholds.line.nearend.1day.CV	133400 (BPV count)	0 - 133315200
DS1.pmthresholds.line.nearend.1day.ES	648 (seconds)	0 - 86400
DS1.pmthresholds.line.nearend.1day.LOSS	10 (seconds)	0 - 86400
DS1.pmthresholds.line.nearend.1day.SES	100 (seconds)	0 - 86400
DS1.pmthresholds.path.farend.15min.CSS	25 (seconds)	0 - 900
DS1.pmthresholds.path.farend.15min.CV	13296 (BIP count)	0 - 287100
DS1.pmthresholds.path.farend.15min.ES	65 (seconds)	0 - 900
DS1.pmthresholds.path.farend.15min.ESA	25 (seconds)	0 - 900
DS1.pmthresholds.path.farend.15min.ESB	25 (seconds)	0 - 900
DS1.pmthresholds.path.farend.15min.SEFS	25 (seconds)	0 - 900
DS1.pmthresholds.path.farend.15min.SES	10 (seconds)	0 - 900
DS1.pmthresholds.path.farend.15min.UAS	10 (seconds)	0 - 900
DS1.pmthresholds.path.farend.1day.CSS	25 (seconds)	0 - 86400
DS1.pmthresholds.path.farend.1day.CV	132960 (BIP count)	0 - 27561600
DS1.pmthresholds.path.farend.1day.ES	648 (seconds)	0 - 86400
DS1.pmthresholds.path.farend.1day.ESA	25 (seconds)	0 - 86400
DS1.pmthresholds.path.farend.1day.ESB	25 (seconds)	0 - 86400
DS1.pmthresholds.path.farend.1day.SEFS	25 (seconds)	0 - 86400
DS1.pmthresholds.path.farend.1day.SES	100 (seconds)	0 - 86400
DS1.pmthresholds.path.farend.1day.UAS	10 (seconds)	0 - 86400
DS1.pmthresholds.path.nearend.15min.AISS	10 (seconds)	0 - 900
DS1.pmthresholds.path.nearend.15min.CV	13296 (BIP count)	0 - 287100
DS1.pmthresholds.path.nearend.15min.ES	65 (seconds)	0 - 900
DS1.pmthresholds.path.nearend.15min.FC	10 (count)	0 - 72
DS1.pmthresholds.path.nearend.15min.SAS	2 (seconds)	0 - 900
DS1.pmthresholds.path.nearend.15min.SES	10 (seconds)	0 - 900
DS1.pmthresholds.path.nearend.15min.UAS	10 (seconds)	0 - 900
DS1.pmthresholds.path.nearend.1day.AISS	10 (seconds)	0 - 86400
DS1.pmthresholds.path.nearend.1day.CV	132960 (BIP count)	0 - 27561600
DS1.pmthresholds.path.nearend.1day.ES	648 (seconds)	0 - 86400
DS1.pmthresholds.path.nearend.1day.FC	40 (count)	0 - 6912
DS1.pmthresholds.path.nearend.1day.SAS	17 (seconds)	0 - 86400
DS1.pmthresholds.path.nearend.1day.SES	100 (seconds)	0 - 86400
DS1.pmthresholds.path.nearend.1day.UAS	10 (seconds)	0 - 86400

Table C-1 DS-1 Card Default Settings (continued)

Default Name	Default Value	Default Domain
DS1.pmthresholds.sts.farend.15min.CV	15 (B3 count)	0 - 2160000
DS1.pmthresholds.sts.farend.15min.ES	12 (seconds)	0 - 900
DS1.pmthresholds.sts.farend.15min.FC	10 (count)	0 - 72
DS1.pmthresholds.sts.farend.15min.SES	3 (seconds)	0 - 900
DS1.pmthresholds.sts.farend.15min.UAS	10 (seconds)	0 - 900
DS1.pmthresholds.sts.farend.1day.CV	125 (B3 count)	0 - 207360000
DS1.pmthresholds.sts.farend.1day.ES	100 (seconds)	0 - 86400
DS1.pmthresholds.sts.farend.1day.FC	40 (count)	0 - 6912
DS1.pmthresholds.sts.farend.1day.SES	7 (seconds)	0 - 86400
DS1.pmthresholds.sts.farend.1day.UAS	10 (seconds)	0 - 86400
DS1.pmthresholds.sts.nearend.15min.CV	15 (B3 count)	0 - 2160000
DS1.pmthresholds.sts.nearend.15min.ES	12 (seconds)	0 - 900
DS1.pmthresholds.sts.nearend.15min.FC	10 (count)	0 - 72
DS1.pmthresholds.sts.nearend.15min.SES	3 (seconds)	0 - 900
DS1.pmthresholds.sts.nearend.15min.UAS	10 (seconds)	0 - 900
DS1.pmthresholds.sts.nearend.1day.CV	125 (B3 count)	0 - 207360000
DS1.pmthresholds.sts.nearend.1day.ES	100 (seconds)	0 - 86400
DS1.pmthresholds.sts.nearend.1day.FC	40 (count)	0 - 6912
DS1.pmthresholds.sts.nearend.1day.SES	7 (seconds)	0 - 86400
DS1.pmthresholds.sts.nearend.1day.UAS	10 (seconds)	0 - 86400
DS1.pmthresholds.vt.farend.15min.CV	15 (BIP8 count)	0 - 2160000
DS1.pmthresholds.vt.farend.15min.ES	12 (seconds)	0 - 900
DS1.pmthresholds.vt.farend.15min.SES	3 (seconds)	0 - 900
DS1.pmthresholds.vt.farend.15min.UAS	10 (seconds)	0 - 900
DS1.pmthresholds.vt.farend.1day.CV	125 (BIP8 count)	0 - 207360000
DS1.pmthresholds.vt.farend.1day.ES	100 (seconds)	0 - 86400
DS1.pmthresholds.vt.farend.1day.SES	7 (seconds)	0 - 86400
DS1.pmthresholds.vt.farend.1day.UAS	10 (seconds)	0 - 86400
DS1.pmthresholds.vt.nearend.15min.CV	15 (BIP8 count)	0 - 2160000
DS1.pmthresholds.vt.nearend.15min.ES	12 (seconds)	0 - 900
DS1.pmthresholds.vt.nearend.15min.SES	3 (seconds)	0 - 900
DS1.pmthresholds.vt.nearend.15min.UAS	10 (seconds)	0 - 900
DS1.pmthresholds.vt.nearend.1day.CV	125 (BIP8 count)	0 - 207360000
DS1.pmthresholds.vt.nearend.1day.ES	100 (seconds)	0 - 86400
DS1.pmthresholds.vt.nearend.1day.SES	7 (seconds)	0 - 86400
DS1.pmthresholds.vt.nearend.1day.UAS	10 (seconds)	0 - 86400

C.2.3.2 DS1/E1-56 Card Default Settings

Table C-2 lists the DS1/E1-56 card default settings.

Table C-2 DS1/E1-56 Card Default Settings

Default Name	Default Value	Default Domain
DS1-E1-56.config.OperatingMode	All DS1	All DS1, All E1
DS1-E1-56.config.PortToVtMappingMode	GR253	Industry when OperatingMode All E1; GR253, Industry when OperatingMode All DS1
DS1-E1-56.config.RetimingEnabled	FALSE	TRUE, FALSE
DS1-E1-56.DS1-PORT.config.AdminSSMIn	STU	PRS, STU, ST2, TNC, ST3E, ST3, SMC, ST4, DUS, RES
DS1-E1-56.DS1-PORT.config.AINSSoakTime	08:00 (hours:mins)	00:00, 00:15, 00:30 .. 48:00
DS1-E1-56.DS1-PORT.config.Ds1Mapping	Asynchronous	Asynchronous when LineType UNFRAMED, UNFRAMED; Asynchronous, Byte Synchronous when LineType ESF, D4, E1_MF, E1_CRCMF, AUTO FRAME, J_ESF
DS1-E1-56.DS1-PORT.config.FdlMode	T1.403	T1.403 when LineType UNFRAMED, AUTO FRAME; T1.403, BFDL when LineType ESF, D4, J_ESF
DS1-E1-56.DS1-PORT.config.LineCoding	AMI	B8ZS, AMI
DS1-E1-56.DS1-PORT.config.LineLength	0 - 131 ft	0 - 131 ft, 132 - 262 ft, 263 - 393 ft, 394 - 524 ft, 525 - 655 ft
DS1-E1-56.DS1-PORT.config.LineType	AUTO FRAME	ESF, D4, UNFRAMED, AUTO FRAME, J_ESF
DS1-E1-56.DS1-PORT.config.RetimingEnabled	FALSE	TRUE, FALSE
DS1-E1-56.DS1-PORT.config.SDBER	1E-7	1E-5, 1E-6, 1E-7, 1E-8, 1E-9
DS1-E1-56.DS1-PORT.config.SendDoNotUse	FALSE	TRUE, FALSE
DS1-E1-56.DS1-PORT.config.SFBER	1E-4	1E-3, 1E-4, 1E-5
DS1-E1-56.DS1-PORT.config.State	OOS,DSBLD	IS, OOS,DSBLD, OOS,MT, IS,AINS
DS1-E1-56.DS1-PORT.config.SyncMsgIn	FALSE	FALSE when LineType D4, E1_MF, E1_CRCMF, UNFRAMED, AUTO FRAME; FALSE, TRUE when LineType ESF, J_ESF
DS1-E1-56.DS1-PORT.pmthresholds.ds1network.farend.15min.ESFE	65 (seconds)	0 - 900
DS1-E1-56.DS1-PORT.pmthresholds.ds1network.farend.15min.ESNE	65 (seconds)	0 - 900
DS1-E1-56.DS1-PORT.pmthresholds.ds1network.farend.15min.SESFE	10 (seconds)	0 - 900

Table C-2 DS1/E1-56 Card Default Settings (continued)

Default Name	Default Value	Default Domain
DS1-E1-56.DS1-PORT.pmthresholds.ds1network.farend.15min.SESNE	10 (seconds)	0 - 900
DS1-E1-56.DS1-PORT.pmthresholds.ds1network.farend.15min.UASFE	10 (seconds)	0 - 900
DS1-E1-56.DS1-PORT.pmthresholds.ds1network.farend.15min.UASNE	10 (seconds)	0 - 900
DS1-E1-56.DS1-PORT.pmthresholds.ds1network.farend.1day.ESFE	648 (seconds)	0 - 86400
DS1-E1-56.DS1-PORT.pmthresholds.ds1network.farend.1day.ESNE	648 (seconds)	0 - 86400
DS1-E1-56.DS1-PORT.pmthresholds.ds1network.farend.1day.SESFE	100 (seconds)	0 - 86400
DS1-E1-56.DS1-PORT.pmthresholds.ds1network.farend.1day.SESNE	100 (seconds)	0 - 86400
DS1-E1-56.DS1-PORT.pmthresholds.ds1network.farend.1day.UASFE	10 (seconds)	0 - 86400
DS1-E1-56.DS1-PORT.pmthresholds.ds1network.farend.1day.UASNE	10 (seconds)	0 - 86400
DS1-E1-56.DS1-PORT.pmthresholds.line.farend.15min.ES	65 (seconds)	0 - 900
DS1-E1-56.DS1-PORT.pmthresholds.line.farend.1day.ES	648 (seconds)	0 - 86400
DS1-E1-56.DS1-PORT.pmthresholds.line.nearend.15min.CV	13340 (BPV count)	0 - 1388700
DS1-E1-56.DS1-PORT.pmthresholds.line.nearend.15min.ES	65 (seconds)	0 - 900
DS1-E1-56.DS1-PORT.pmthresholds.line.nearend.15min.LOSS	10 (seconds)	0 - 900
DS1-E1-56.DS1-PORT.pmthresholds.line.nearend.15min.SES	10 (seconds)	0 - 900
DS1-E1-56.DS1-PORT.pmthresholds.line.nearend.1day.CV	133400 (BPV count)	0 - 133315200
DS1-E1-56.DS1-PORT.pmthresholds.line.nearend.1day.ES	648 (seconds)	0 - 86400
DS1-E1-56.DS1-PORT.pmthresholds.line.nearend.1day.LOSS	10 (seconds)	0 - 86400
DS1-E1-56.DS1-PORT.pmthresholds.line.nearend.1day.SES	100 (seconds)	0 - 86400
DS1-E1-56.DS1-PORT.pmthresholds.path.farend.15min.CSS	25 (seconds)	0 - 900
DS1-E1-56.DS1-PORT.pmthresholds.path.farend.15min.CV	13296 (BIP count)	0 - 287100
DS1-E1-56.DS1-PORT.pmthresholds.path.farend.15min.ES	65 (seconds)	0 - 900
DS1-E1-56.DS1-PORT.pmthresholds.path.farend.15min.ESA	25 (seconds)	0 - 900
DS1-E1-56.DS1-PORT.pmthresholds.path.farend.15min.ESB	25 (seconds)	0 - 900
DS1-E1-56.DS1-PORT.pmthresholds.path.farend.15min.FC	10 (count)	0 - 72
DS1-E1-56.DS1-PORT.pmthresholds.path.farend.15min.SEFS	25 (seconds)	0 - 900
DS1-E1-56.DS1-PORT.pmthresholds.path.farend.15min.SES	10 (seconds)	0 - 900
DS1-E1-56.DS1-PORT.pmthresholds.path.farend.15min.UAS	10 (seconds)	0 - 900
DS1-E1-56.DS1-PORT.pmthresholds.path.farend.1day.CSS	25 (seconds)	0 - 86400

Table C-2 DS1/E1-56 Card Default Settings (continued)

Default Name	Default Value	Default Domain
DS1-E1-56.DS1-PORT.pmthresholds.path.farend.1day.CV	132960 (BIP count)	0 - 27561600
DS1-E1-56.DS1-PORT.pmthresholds.path.farend.1day.ES	648 (seconds)	0 - 86400
DS1-E1-56.DS1-PORT.pmthresholds.path.farend.1day.ESA	25 (seconds)	0 - 86400
DS1-E1-56.DS1-PORT.pmthresholds.path.farend.1day.ESB	25 (seconds)	0 - 86400
DS1-E1-56.DS1-PORT.pmthresholds.path.farend.1day.FC	40 (count)	0 - 6912
DS1-E1-56.DS1-PORT.pmthresholds.path.farend.1day.SEFS	25 (seconds)	0 - 86400
DS1-E1-56.DS1-PORT.pmthresholds.path.farend.1day.SES	100 (seconds)	0 - 86400
DS1-E1-56.DS1-PORT.pmthresholds.path.farend.1day.UAS	10 (seconds)	0 - 86400
DS1-E1-56.DS1-PORT.pmthresholds.path.nearend.15min.AISS	10 (seconds)	0 - 900
DS1-E1-56.DS1-PORT.pmthresholds.path.nearend.15min.CSS	25 (seconds)	0 - 900
DS1-E1-56.DS1-PORT.pmthresholds.path.nearend.15min.CV	13296 (BIP count)	0 - 287100
DS1-E1-56.DS1-PORT.pmthresholds.path.nearend.15min.ES	65 (seconds)	0 - 900
DS1-E1-56.DS1-PORT.pmthresholds.path.nearend.15min.FC	10 (count)	0 - 72
DS1-E1-56.DS1-PORT.pmthresholds.path.nearend.15min.SAS	2 (seconds)	0 - 900
DS1-E1-56.DS1-PORT.pmthresholds.path.nearend.15min.SES	10 (seconds)	0 - 900
DS1-E1-56.DS1-PORT.pmthresholds.path.nearend.15min.UAS	10 (seconds)	0 - 900
DS1-E1-56.DS1-PORT.pmthresholds.path.nearend.1day.AISS	10 (seconds)	0 - 86400
DS1-E1-56.DS1-PORT.pmthresholds.path.nearend.1day.CSS	25 (seconds)	0 - 86400
DS1-E1-56.DS1-PORT.pmthresholds.path.nearend.1day.CV	132960 (BIP count)	0 - 27561600
DS1-E1-56.DS1-PORT.pmthresholds.path.nearend.1day.ES	648 (seconds)	0 - 86400
DS1-E1-56.DS1-PORT.pmthresholds.path.nearend.1day.FC	40 (count)	0 - 6912
DS1-E1-56.DS1-PORT.pmthresholds.path.nearend.1day.SAS	17 (seconds)	0 - 86400
DS1-E1-56.DS1-PORT.pmthresholds.path.nearend.1day.SES	100 (seconds)	0 - 86400
DS1-E1-56.DS1-PORT.pmthresholds.path.nearend.1day.UAS	10 (seconds)	0 - 86400
DS1-E1-56.DS1-PORT.pmthresholds.sts.farend.15min.ES	12 (seconds)	0 - 900
DS1-E1-56.DS1-PORT.pmthresholds.sts.farend.15min.FC	10 (count)	0 - 72
DS1-E1-56.DS1-PORT.pmthresholds.sts.farend.15min.SES	3 (seconds)	0 - 900
DS1-E1-56.DS1-PORT.pmthresholds.sts.farend.15min.UAS	10 (seconds)	0 - 900
DS1-E1-56.DS1-PORT.pmthresholds.sts.farend.1day.ES	100 (seconds)	0 - 86400
DS1-E1-56.DS1-PORT.pmthresholds.sts.farend.1day.FC	40 (count)	0 - 6912

Table C-2 DS1/E1-56 Card Default Settings (continued)

Default Name	Default Value	Default Domain
DS1-E1-56.DS1-PORT.pmthresholds.sts.farend.1day.SES	7 (seconds)	0 - 86400
DS1-E1-56.DS1-PORT.pmthresholds.sts.farend.1day.UAS	10 (seconds)	0 - 86400
DS1-E1-56.DS1-PORT.pmthresholds.sts.nearend.15min.ES	12 (seconds)	0 - 900
DS1-E1-56.DS1-PORT.pmthresholds.sts.nearend.15min.FC	10 (count)	0 - 72
DS1-E1-56.DS1-PORT.pmthresholds.sts.nearend.15min.SES	3 (seconds)	0 - 900
DS1-E1-56.DS1-PORT.pmthresholds.sts.nearend.15min.UAS	10 (seconds)	0 - 900
DS1-E1-56.DS1-PORT.pmthresholds.sts.nearend.1day.ES	100 (seconds)	0 - 86400
DS1-E1-56.DS1-PORT.pmthresholds.sts.nearend.1day.FC	40 (count)	0 - 6912
DS1-E1-56.DS1-PORT.pmthresholds.sts.nearend.1day.SES	7 (seconds)	0 - 86400
DS1-E1-56.DS1-PORT.pmthresholds.sts.nearend.1day.UAS	10 (seconds)	0 - 86400
DS1-E1-56.DS1-PORT.pmthresholds.vt.farend.15min.ES	12 (seconds)	0 - 900
DS1-E1-56.DS1-PORT.pmthresholds.vt.farend.15min.FC	10 (count)	0 - 72
DS1-E1-56.DS1-PORT.pmthresholds.vt.farend.15min.SES	3 (seconds)	0 - 900
DS1-E1-56.DS1-PORT.pmthresholds.vt.farend.15min.UAS	10 (seconds)	0 - 900
DS1-E1-56.DS1-PORT.pmthresholds.vt.farend.1day.ES	100 (seconds)	0 - 86400
DS1-E1-56.DS1-PORT.pmthresholds.vt.farend.1day.FC	40 (count)	0 - 6912
DS1-E1-56.DS1-PORT.pmthresholds.vt.farend.1day.SES	7 (seconds)	0 - 86400
DS1-E1-56.DS1-PORT.pmthresholds.vt.farend.1day.UAS	10 (seconds)	0 - 86400
DS1-E1-56.DS1-PORT.pmthresholds.vt.nearend.15min.ES	12 (seconds)	0 - 900
DS1-E1-56.DS1-PORT.pmthresholds.vt.nearend.15min.FC	10 (count)	0 - 72
DS1-E1-56.DS1-PORT.pmthresholds.vt.nearend.15min.SES	3 (seconds)	0 - 900
DS1-E1-56.DS1-PORT.pmthresholds.vt.nearend.15min.UAS	10 (seconds)	0 - 900
DS1-E1-56.DS1-PORT.pmthresholds.vt.nearend.1day.ES	100 (seconds)	0 - 86400
DS1-E1-56.DS1-PORT.pmthresholds.vt.nearend.1day.FC	40 (count)	0 - 6912
DS1-E1-56.DS1-PORT.pmthresholds.vt.nearend.1day.SES	7 (seconds)	0 - 86400
DS1-E1-56.DS1-PORT.pmthresholds.vt.nearend.1day.UAS	10 (seconds)	0 - 86400
DS1-E1-56.E1-PORT.config.AdminSSMIn	STU	PRS, STU, ST2, TNC, ST3E, ST3, SMC, ST4, DUS, RES
DS1-E1-56.E1-PORT.config.AINSSoakTime	08:00 (hours:mins)	00:00, 00:15, 00:30 .. 48:00
DS1-E1-56.E1-PORT.config.LineCoding	HDB3	HDB3
DS1-E1-56.E1-PORT.config.LineType	AUTO FRAME	E1_MF, E1_CRCMF, AUTO FRAME, UNFRAMED
DS1-E1-56.E1-PORT.config.RetimingEnabled	FALSE	TRUE, FALSE

Table C-2 DS1/E1-56 Card Default Settings (continued)

Default Name	Default Value	Default Domain
DS1-E1-56.E1-PORT.config.SaBit	SA Bit 4	SA Bit 4, SA Bit 5, SA Bit 6, SA Bit 7, SA Bit 8
DS1-E1-56.E1-PORT.config.SDBER	1E-7	1E-5, 1E-6, 1E-7, 1E-8, 1E-9
DS1-E1-56.E1-PORT.config.SendDoNotUse	FALSE	TRUE, FALSE
DS1-E1-56.E1-PORT.config.SFBER	1E-4	1E-3, 1E-4, 1E-5
DS1-E1-56.E1-PORT.config.State	OOS,DSBL D	IS, OOS,DSBLD, OOS,MT, IS,AINS
DS1-E1-56.E1-PORT.config.SyncMsgIn	FALSE	FALSE, TRUE
DS1-E1-56.E1-PORT.pmthresholds.line.nearend.15min.CV	9 (BPV count)	0 - 1388700
DS1-E1-56.E1-PORT.pmthresholds.line.nearend.15min.ES	65 (seconds)	0 - 900
DS1-E1-56.E1-PORT.pmthresholds.line.nearend.15min.LOSS	10 (seconds)	0 - 900
DS1-E1-56.E1-PORT.pmthresholds.line.nearend.15min.SES	10 (seconds)	0 - 900
DS1-E1-56.E1-PORT.pmthresholds.line.nearend.1day.CV	90 (BPV count)	0 - 133315200
DS1-E1-56.E1-PORT.pmthresholds.line.nearend.1day.ES	648 (seconds)	0 - 86400
DS1-E1-56.E1-PORT.pmthresholds.line.nearend.1day.LOSS	10 (seconds)	0 - 900
DS1-E1-56.E1-PORT.pmthresholds.line.nearend.1day.SES	100 (seconds)	0 - 86400
DS1-E1-56.E1-PORT.pmthresholds.path.nearend.15min.AISS	10 (seconds)	0 - 900
DS1-E1-56.E1-PORT.pmthresholds.path.nearend.15min.BBE	9 (count)	0 - 287100
DS1-E1-56.E1-PORT.pmthresholds.path.nearend.15min.EB	9 (count)	0 - 450000
DS1-E1-56.E1-PORT.pmthresholds.path.nearend.15min.ES	65 (seconds)	0 - 900
DS1-E1-56.E1-PORT.pmthresholds.path.nearend.15min.SES	10 (seconds)	0 - 900
DS1-E1-56.E1-PORT.pmthresholds.path.nearend.15min.UAS	10 (seconds)	0 - 900
DS1-E1-56.E1-PORT.pmthresholds.path.nearend.1day.AISS	10 (seconds)	0 - 86400
DS1-E1-56.E1-PORT.pmthresholds.path.nearend.1day.BBE	90 (count)	0 - 27561600
DS1-E1-56.E1-PORT.pmthresholds.path.nearend.1day.EB	90 (count)	0 - 43200000
DS1-E1-56.E1-PORT.pmthresholds.path.nearend.1day.ES	648 (seconds)	0 - 86400
DS1-E1-56.E1-PORT.pmthresholds.path.nearend.1day.SES	100 (seconds)	0 - 86400
DS1-E1-56.E1-PORT.pmthresholds.path.nearend.1day.UAS	10 (seconds)	0 - 86400
DS1-E1-56.E1-PORT.pmthresholds.sts.farend.15min.ES	12 (seconds)	0 - 900
DS1-E1-56.E1-PORT.pmthresholds.sts.farend.15min.FC	10 (count)	0 - 72
DS1-E1-56.E1-PORT.pmthresholds.sts.farend.15min.SES	3 (seconds)	0 - 900
DS1-E1-56.E1-PORT.pmthresholds.sts.farend.15min.UAS	10 (seconds)	0 - 900

Table C-2 DS1/E1-56 Card Default Settings (continued)

Default Name	Default Value	Default Domain
DS1-E1-56.E1-PORT.pmthresholds.sts.farend.1day.ES	100 (seconds)	0 - 86400
DS1-E1-56.E1-PORT.pmthresholds.sts.farend.1day.FC	40 (count)	0 - 6912
DS1-E1-56.E1-PORT.pmthresholds.sts.farend.1day.SES	7 (seconds)	0 - 86400
DS1-E1-56.E1-PORT.pmthresholds.sts.farend.1day.UAS	10 (seconds)	0 - 86400
DS1-E1-56.E1-PORT.pmthresholds.sts.nearend.15min.ES	12 (seconds)	0 - 900
DS1-E1-56.E1-PORT.pmthresholds.sts.nearend.15min.FC	10 (count)	0 - 72
DS1-E1-56.E1-PORT.pmthresholds.sts.nearend.15min.SES	3 (seconds)	0 - 900
DS1-E1-56.E1-PORT.pmthresholds.sts.nearend.15min.UAS	10 (seconds)	0 - 900
DS1-E1-56.E1-PORT.pmthresholds.sts.nearend.1day.ES	100 (seconds)	0 - 86400
DS1-E1-56.E1-PORT.pmthresholds.sts.nearend.1day.FC	40 (count)	0 - 6912
DS1-E1-56.E1-PORT.pmthresholds.sts.nearend.1day.SES	7 (seconds)	0 - 86400
DS1-E1-56.E1-PORT.pmthresholds.sts.nearend.1day.UAS	10 (seconds)	0 - 86400
DS1-E1-56.E1-PORT.pmthresholds.vt.farend.15min.ES	65 (seconds)	0 - 900
DS1-E1-56.E1-PORT.pmthresholds.vt.farend.15min.FC	10 (count)	0 - 72
DS1-E1-56.E1-PORT.pmthresholds.vt.farend.15min.SES	10 (seconds)	0 - 900
DS1-E1-56.E1-PORT.pmthresholds.vt.farend.15min.UAS	10 (seconds)	0 - 900
DS1-E1-56.E1-PORT.pmthresholds.vt.farend.1day.ES	648 (seconds)	0 - 86400
DS1-E1-56.E1-PORT.pmthresholds.vt.farend.1day.FC	40 (count)	0 - 6912
DS1-E1-56.E1-PORT.pmthresholds.vt.farend.1day.SES	100 (seconds)	0 - 86400
DS1-E1-56.E1-PORT.pmthresholds.vt.farend.1day.UAS	10 (seconds)	0 - 86400
DS1-E1-56.E1-PORT.pmthresholds.vt.nearend.15min.ES	65 (seconds)	0 - 900
DS1-E1-56.E1-PORT.pmthresholds.vt.nearend.15min.FC	10 (count)	0 - 72
DS1-E1-56.E1-PORT.pmthresholds.vt.nearend.15min.SES	10 (seconds)	0 - 900
DS1-E1-56.E1-PORT.pmthresholds.vt.nearend.15min.UAS	10 (seconds)	0 - 900
DS1-E1-56.E1-PORT.pmthresholds.vt.nearend.1day.ES	648 (seconds)	0 - 86400
DS1-E1-56.E1-PORT.pmthresholds.vt.nearend.1day.FC	40 (count)	0 - 6912
DS1-E1-56.E1-PORT.pmthresholds.vt.nearend.1day.SES	100 (seconds)	0 - 86400
DS1-E1-56.E1-PORT.pmthresholds.vt.nearend.1day.UAS	10 (seconds)	0 - 86400

C.2.3.3 DS-3 Card Default Settings

Table C-3 lists the DS-3 card default settings.

Table C-3 DS-3 Card Default Settings

Default Name	Default Value	Default Domain
DS3.config.AINSSoakTime	08:00 (hours:mins)	00:00, 00:15, 00:30 .. 48:00
DS3.config.LineLength	0 - 225 ft	0 - 225 ft, 226 - 450 ft
DS3.config.SDBER	1E-7	1E-5, 1E-6, 1E-7, 1E-8, 1E-9
DS3.config.SFBER	1E-4	1E-3, 1E-4, 1E-5
DS3.config.State	IS,AINS	IS, OOS,DSBLD, OOS,MT, IS,AINS
DS3.pmthresholds.line.nearend.15min.CV	387 (BPV count)	0 - 38700
DS3.pmthresholds.line.nearend.15min.ES	25 (seconds)	0 - 900
DS3.pmthresholds.line.nearend.15min.LOSS	10 (seconds)	0 - 900
DS3.pmthresholds.line.nearend.15min.SES	4 (seconds)	0 - 900
DS3.pmthresholds.line.nearend.1day.CV	3865 (BPV count)	0 - 3715200
DS3.pmthresholds.line.nearend.1day.ES	250 (seconds)	0 - 86400
DS3.pmthresholds.line.nearend.1day.LOSS	10 (seconds)	0 - 86400
DS3.pmthresholds.line.nearend.1day.SES	40 (seconds)	0 - 86400
DS3.pmthresholds.sts.farend.15min.CV	15 (G1 count)	0 - 2160000
DS3.pmthresholds.sts.farend.15min.ES	12 (seconds)	0 - 900
DS3.pmthresholds.sts.farend.15min.FC	10 (count)	0 - 72
DS3.pmthresholds.sts.farend.15min.SES	3 (seconds)	0 - 900
DS3.pmthresholds.sts.farend.15min.UAS	10 (seconds)	0 - 900
DS3.pmthresholds.sts.farend.1day.CV	125 (G1 count)	0 - 207360000
DS3.pmthresholds.sts.farend.1day.ES	100 (seconds)	0 - 86400
DS3.pmthresholds.sts.farend.1day.FC	40 (count)	0 - 6912
DS3.pmthresholds.sts.farend.1day.SES	7 (seconds)	0 - 86400
DS3.pmthresholds.sts.farend.1day.UAS	10 (seconds)	0 - 86400
DS3.pmthresholds.sts.nearend.15min.CV	15 (B3 count)	0 - 2160000
DS3.pmthresholds.sts.nearend.15min.ES	12 (seconds)	0 - 900
DS3.pmthresholds.sts.nearend.15min.FC	10 (count)	0 - 72
DS3.pmthresholds.sts.nearend.15min.SES	3 (seconds)	0 - 900
DS3.pmthresholds.sts.nearend.15min.UAS	10 (seconds)	0 - 900
DS3.pmthresholds.sts.nearend.1day.CV	125 (B3 count)	0 - 207360000
DS3.pmthresholds.sts.nearend.1day.ES	100 (seconds)	0 - 86400
DS3.pmthresholds.sts.nearend.1day.FC	40 (count)	0 - 6912
DS3.pmthresholds.sts.nearend.1day.SES	7 (seconds)	0 - 86400
DS3.pmthresholds.sts.nearend.1day.UAS	10 (seconds)	0 - 86400

C.2.3.4 DS3/EC1-48 Card Default Settings

Table C-4 lists the DS3/EC1-48 card default settings.

Table C-4 DS3/EC1-48 Card Default Settings

Default Name	Default Value	Default Domain
DS3-EC1-48.Broadband.portAssignment	DS3-PORT	UNASSIGNED, DS3-PORT, EC1-PORT
DS3-EC1-48.DS3-PORT.config.AINSSoakTime	08:00 (hours:mins)	00:00, 00:15, 00:30 .. 48:00
DS3-EC1-48.DS3-PORT.config.FeInhibitLpbk	FALSE	TRUE, FALSE
DS3-EC1-48.DS3-PORT.config.LineLength	0 - 225 ft	0 - 225 ft, 226 - 450 ft
DS3-EC1-48.DS3-PORT.config.LineType	UNFRAMED	UNFRAMED, M13, C BIT, AUTO PROVISION FMT
DS3-EC1-48.DS3-PORT.config.SDBER	1E-7	1E-5, 1E-6, 1E-7, 1E-8, 1E-9
DS3-EC1-48.DS3-PORT.config.SFBER	1E-4	1E-3, 1E-4, 1E-5
DS3-EC1-48.DS3-PORT.config.State	IS,AINS	IS, OOS,DSBLD, OOS,MT, IS,AINS
DS3-EC1-48.DS3-PORT.pmthresholds.cpbitpath.farend.15min.AISS	10 (seconds)	0 - 86400
DS3-EC1-48.DS3-PORT.pmthresholds.cpbitpath.farend.15min.CV	382 (BIP count)	0 - 287100
DS3-EC1-48.DS3-PORT.pmthresholds.cpbitpath.farend.15min.ES	25 (seconds)	0 - 900
DS3-EC1-48.DS3-PORT.pmthresholds.cpbitpath.farend.15min.SAS	2 (seconds)	0 - 900
DS3-EC1-48.DS3-PORT.pmthresholds.cpbitpath.farend.15min.SES	4 (seconds)	0 - 900
DS3-EC1-48.DS3-PORT.pmthresholds.cpbitpath.farend.15min.UAS	10 (seconds)	0 - 900
DS3-EC1-48.DS3-PORT.pmthresholds.cpbitpath.farend.1day.AISS	10 (seconds)	0 - 86400
DS3-EC1-48.DS3-PORT.pmthresholds.cpbitpath.farend.1day.CV	3820 (BIP count)	0 - 27561600
DS3-EC1-48.DS3-PORT.pmthresholds.cpbitpath.farend.1day.ES	250 (seconds)	0 - 86400
DS3-EC1-48.DS3-PORT.pmthresholds.cpbitpath.farend.1day.SAS	8 (seconds)	0 - 86400
DS3-EC1-48.DS3-PORT.pmthresholds.cpbitpath.farend.1day.SES	40 (seconds)	0 - 86400
DS3-EC1-48.DS3-PORT.pmthresholds.cpbitpath.farend.1day.UAS	10 (seconds)	0 - 86400
DS3-EC1-48.DS3-PORT.pmthresholds.cpbitpath.nearend.15min.AISS	10 (seconds)	0 - 900
DS3-EC1-48.DS3-PORT.pmthresholds.cpbitpath.nearend.15min.CV	382 (BIP count)	0 - 287100
DS3-EC1-48.DS3-PORT.pmthresholds.cpbitpath.nearend.15min.ES	25 (seconds)	0 - 900
DS3-EC1-48.DS3-PORT.pmthresholds.cpbitpath.nearend.15min.SAS	2 (seconds)	0 - 900
DS3-EC1-48.DS3-PORT.pmthresholds.cpbitpath.nearend.15min.SES	4 (seconds)	0 - 900
DS3-EC1-48.DS3-PORT.pmthresholds.cpbitpath.nearend.15min.UAS	10 (seconds)	0 - 900
DS3-EC1-48.DS3-PORT.pmthresholds.cpbitpath.nearend.1day.AISS	10 (seconds)	0 - 86400

Table C-4 DS3/EC1-48 Card Default Settings (continued)

Default Name	Default Value	Default Domain
DS3-EC1-48.DS3-PORT.pmthresholds.cpbithpath.nearend.1day.CV	3820 (BIP count)	0 - 27561600
DS3-EC1-48.DS3-PORT.pmthresholds.cpbithpath.nearend.1day.ES	250 (seconds)	0 - 86400
DS3-EC1-48.DS3-PORT.pmthresholds.cpbithpath.nearend.1day.SAS	8 (seconds)	0 - 86400
DS3-EC1-48.DS3-PORT.pmthresholds.cpbithpath.nearend.1day.SES	40 (seconds)	0 - 86400
DS3-EC1-48.DS3-PORT.pmthresholds.cpbithpath.nearend.1day.UAS	10 (seconds)	0 - 86400
DS3-EC1-48.DS3-PORT.pmthresholds.line.nearend.15min.CV	387 (BPV count)	0 - 38700
DS3-EC1-48.DS3-PORT.pmthresholds.line.nearend.15min.ES	25 (seconds)	0 - 900
DS3-EC1-48.DS3-PORT.pmthresholds.line.nearend.15min.LOSS	10 (seconds)	0 - 900
DS3-EC1-48.DS3-PORT.pmthresholds.line.nearend.15min.SES	4 (seconds)	0 - 900
DS3-EC1-48.DS3-PORT.pmthresholds.line.nearend.1day.CV	3865 (BPV count)	0 - 3715200
DS3-EC1-48.DS3-PORT.pmthresholds.line.nearend.1day.ES	250 (seconds)	0 - 86400
DS3-EC1-48.DS3-PORT.pmthresholds.line.nearend.1day.LOSS	10 (seconds)	0 - 86400
DS3-EC1-48.DS3-PORT.pmthresholds.line.nearend.1day.SES	40 (seconds)	0 - 86400
DS3-EC1-48.DS3-PORT.pmthresholds.pbitpath.nearend.15min.AISS	10 (seconds)	0 - 900
DS3-EC1-48.DS3-PORT.pmthresholds.pbitpath.nearend.15min.CV	382 (BIP count)	0 - 287100
DS3-EC1-48.DS3-PORT.pmthresholds.pbitpath.nearend.15min.ES	25 (seconds)	0 - 900
DS3-EC1-48.DS3-PORT.pmthresholds.pbitpath.nearend.15min.SAS	2 (seconds)	0 - 900
DS3-EC1-48.DS3-PORT.pmthresholds.pbitpath.nearend.15min.SES	4 (seconds)	0 - 900
DS3-EC1-48.DS3-PORT.pmthresholds.pbitpath.nearend.15min.UAS	10 (seconds)	0 - 900
DS3-EC1-48.DS3-PORT.pmthresholds.pbitpath.nearend.1day.AISS	10 (seconds)	0 - 86400
DS3-EC1-48.DS3-PORT.pmthresholds.pbitpath.nearend.1day.CV	3820 (BIP count)	0 - 27561600
DS3-EC1-48.DS3-PORT.pmthresholds.pbitpath.nearend.1day.ES	250 (seconds)	0 - 86400
DS3-EC1-48.DS3-PORT.pmthresholds.pbitpath.nearend.1day.SAS	8 (seconds)	0 - 86400
DS3-EC1-48.DS3-PORT.pmthresholds.pbitpath.nearend.1day.SES	40 (seconds)	0 - 86400
DS3-EC1-48.DS3-PORT.pmthresholds.pbitpath.nearend.1day.UAS	10 (seconds)	0 - 86400
DS3-EC1-48.DS3-PORT.pmthresholds.sts.farend.15min.CV	15 (G1 count)	0 - 2160000
DS3-EC1-48.DS3-PORT.pmthresholds.sts.farend.15min.ES	12 (seconds)	0 - 900
DS3-EC1-48.DS3-PORT.pmthresholds.sts.farend.15min.FC	10 (count)	0 - 72
DS3-EC1-48.DS3-PORT.pmthresholds.sts.farend.15min.SES	3 (seconds)	0 - 900
DS3-EC1-48.DS3-PORT.pmthresholds.sts.farend.15min.UAS	10 (seconds)	0 - 900
DS3-EC1-48.DS3-PORT.pmthresholds.sts.farend.1day.CV	125 (G1 count)	0 - 207360000
DS3-EC1-48.DS3-PORT.pmthresholds.sts.farend.1day.ES	100 (seconds)	0 - 86400

Table C-4 DS3/EC1-48 Card Default Settings (continued)

Default Name	Default Value	Default Domain
DS3-EC1-48.DS3-PORT.pmthresholds.sts.farend.1day.FC	40 (count)	0 - 6912
DS3-EC1-48.DS3-PORT.pmthresholds.sts.farend.1day.SES	7 (seconds)	0 - 86400
DS3-EC1-48.DS3-PORT.pmthresholds.sts.farend.1day.UAS	10 (seconds)	0 - 86400
DS3-EC1-48.DS3-PORT.pmthresholds.sts.nearend.15min.CV	15 (B3 count)	0 - 2160000
DS3-EC1-48.DS3-PORT.pmthresholds.sts.nearend.15min.ES	12 (seconds)	0 - 900
DS3-EC1-48.DS3-PORT.pmthresholds.sts.nearend.15min.FC	10 (count)	0 - 72
DS3-EC1-48.DS3-PORT.pmthresholds.sts.nearend.15min.SES	3 (seconds)	0 - 900
DS3-EC1-48.DS3-PORT.pmthresholds.sts.nearend.15min.UAS	10 (seconds)	0 - 900
DS3-EC1-48.DS3-PORT.pmthresholds.sts.nearend.1day.CV	125 (B3 count)	0 - 207360000
DS3-EC1-48.DS3-PORT.pmthresholds.sts.nearend.1day.ES	100 (seconds)	0 - 86400
DS3-EC1-48.DS3-PORT.pmthresholds.sts.nearend.1day.FC	40 (count)	0 - 6912
DS3-EC1-48.DS3-PORT.pmthresholds.sts.nearend.1day.SES	7 (seconds)	0 - 86400
DS3-EC1-48.DS3-PORT.pmthresholds.sts.nearend.1day.UAS	10 (seconds)	0 - 86400
DS3-EC1-48.EC1-PORT.config.line.AINSSoakTime	08:00 (hours:mins)	00:00, 00:15, 00:30 .. 48:00
DS3-EC1-48.EC1-PORT.config.line.LineLength	0 - 225 ft	0 - 225 ft, 226 - 450 ft
DS3-EC1-48.EC1-PORT.config.line.PJStsMon#	0 (STS #)	0 - 1
DS3-EC1-48.EC1-PORT.config.line.SDBER	1E-7	1E-5, 1E-6, 1E-7, 1E-8, 1E-9
DS3-EC1-48.EC1-PORT.config.line.SFBER	1E-4	1E-3, 1E-4, 1E-5
DS3-EC1-48.EC1-PORT.config.line.State	IS,AINS	IS, OOS,DSBLD, OOS,MT, IS,AINS
DS3-EC1-48.EC1-PORT.config.sts.IPPMEnabled	FALSE	TRUE, FALSE
DS3-EC1-48.EC1-PORT.pmthresholds.line.farend.15min.CV	1312 (B2 count)	0 - 137700
DS3-EC1-48.EC1-PORT.pmthresholds.line.farend.15min.ES	87 (seconds)	0 - 900
DS3-EC1-48.EC1-PORT.pmthresholds.line.farend.15min.FC	10 (count)	0 - 72
DS3-EC1-48.EC1-PORT.pmthresholds.line.farend.15min.SES	1 (seconds)	0 - 900
DS3-EC1-48.EC1-PORT.pmthresholds.line.farend.15min.UAS	3 (seconds)	0 - 900
DS3-EC1-48.EC1-PORT.pmthresholds.line.farend.1day.CV	13120 (B2 count)	0 - 8850600
DS3-EC1-48.EC1-PORT.pmthresholds.line.farend.1day.ES	864 (seconds)	0 - 86400
DS3-EC1-48.EC1-PORT.pmthresholds.line.farend.1day.FC	40 (count)	0 - 72
DS3-EC1-48.EC1-PORT.pmthresholds.line.farend.1day.SES	4 (seconds)	0 - 86400
DS3-EC1-48.EC1-PORT.pmthresholds.line.farend.1day.UAS	10 (seconds)	0 - 86400
DS3-EC1-48.EC1-PORT.pmthresholds.line.nearend.15min.CV	1312 (B2 count)	0 - 137700
DS3-EC1-48.EC1-PORT.pmthresholds.line.nearend.15min.ES	87 (seconds)	0 - 900

Table C-4 DS3/EC1-48 Card Default Settings (continued)

Default Name	Default Value	Default Domain
DS3-EC1-48.EC1-PORT.pmthresholds.line.nearend.15min.FC	10 (count)	0 - 72
DS3-EC1-48.EC1-PORT.pmthresholds.line.nearend.15min.SES	1 (seconds)	0 - 900
DS3-EC1-48.EC1-PORT.pmthresholds.line.nearend.15min.UAS	3 (seconds)	0 - 900
DS3-EC1-48.EC1-PORT.pmthresholds.line.nearend.1day.CV	13120 (B2 count)	0 - 13219200
DS3-EC1-48.EC1-PORT.pmthresholds.line.nearend.1day.ES	864 (seconds)	0 - 86400
DS3-EC1-48.EC1-PORT.pmthresholds.line.nearend.1day.FC	40 (count)	0 - 6912
DS3-EC1-48.EC1-PORT.pmthresholds.line.nearend.1day.SES	4 (seconds)	0 - 86400
DS3-EC1-48.EC1-PORT.pmthresholds.line.nearend.1day.UAS	10 (seconds)	0 - 86400
DS3-EC1-48.EC1-PORT.pmthresholds.section.nearend.15min.CV	10000 (B1 count)	0 - 138600
DS3-EC1-48.EC1-PORT.pmthresholds.section.nearend.15min.ES	500 (seconds)	0 - 900
DS3-EC1-48.EC1-PORT.pmthresholds.section.nearend.15min.SEFS	500 (seconds)	0 - 900
DS3-EC1-48.EC1-PORT.pmthresholds.section.nearend.15min.SES	500 (seconds)	0 - 900
DS3-EC1-48.EC1-PORT.pmthresholds.section.nearend.1day.CV	100000 (B1 count)	0 - 13305600
DS3-EC1-48.EC1-PORT.pmthresholds.section.nearend.1day.ES	5000 (seconds)	0 - 86400
DS3-EC1-48.EC1-PORT.pmthresholds.section.nearend.1day.SEFS	5000 (seconds)	0 - 86400
DS3-EC1-48.EC1-PORT.pmthresholds.section.nearend.1day.SES	5000 (seconds)	0 - 86400
DS3-EC1-48.EC1-PORT.pmthresholds.sts1.nearend.15min.CV	15 (B3 count)	0 - 2160000
DS3-EC1-48.EC1-PORT.pmthresholds.sts1.nearend.15min.ES	12 (seconds)	0 - 900
DS3-EC1-48.EC1-PORT.pmthresholds.sts1.nearend.15min.FC	10 (count)	0 - 72
DS3-EC1-48.EC1-PORT.pmthresholds.sts1.nearend.15min.NPJC-PDET	60 (count)	0 - 7200000
DS3-EC1-48.EC1-PORT.pmthresholds.sts1.nearend.15min.NPJC-PGEN	60 (count)	0 - 7200000
DS3-EC1-48.EC1-PORT.pmthresholds.sts1.nearend.15min.PJCDIFF	60 (count)	0 - 1200
DS3-EC1-48.EC1-PORT.pmthresholds.sts1.nearend.15min.PJCS-PDET	100 (seconds)	0 - 7200000
DS3-EC1-48.EC1-PORT.pmthresholds.sts1.nearend.15min.PJCS-PGEN	100 (seconds)	0 - 7200000
DS3-EC1-48.EC1-PORT.pmthresholds.sts1.nearend.15min.PPJC-PDET	60 (count)	0 - 7200000
DS3-EC1-48.EC1-PORT.pmthresholds.sts1.nearend.15min.PPJC-PGEN	60 (count)	0 - 7200000
DS3-EC1-48.EC1-PORT.pmthresholds.sts1.nearend.15min.SES	3 (seconds)	0 - 900
DS3-EC1-48.EC1-PORT.pmthresholds.sts1.nearend.15min.UAS	10 (seconds)	0 - 900
DS3-EC1-48.EC1-PORT.pmthresholds.sts1.nearend.1day.CV	125 (B3 count)	0 - 207360000
DS3-EC1-48.EC1-PORT.pmthresholds.sts1.nearend.1day.ES	100 (seconds)	0 - 86400
DS3-EC1-48.EC1-PORT.pmthresholds.sts1.nearend.1day.FC	40 (count)	0 - 6912

Table C-4 DS3/EC1-48 Card Default Settings (continued)

Default Name	Default Value	Default Domain
DS3-EC1-48.EC1-PORT.pmthresholds.sts1.nearend.1day.NPJC-PDET	5760 (count)	0 - 691200000
DS3-EC1-48.EC1-PORT.pmthresholds.sts1.nearend.1day.NPJC-PGEN	5760 (count)	0 - 691200000
DS3-EC1-48.EC1-PORT.pmthresholds.sts1.nearend.1day.PJCDIFF	5760 (count)	0 - 115200
DS3-EC1-48.EC1-PORT.pmthresholds.sts1.nearend.1day.PJCS-PDET	9600 (seconds)	0 - 691200000
DS3-EC1-48.EC1-PORT.pmthresholds.sts1.nearend.1day.PJCS-PGEN	9600 (seconds)	0 - 691200000
DS3-EC1-48.EC1-PORT.pmthresholds.sts1.nearend.1day.PPJC-PDET	5760 (count)	0 - 691200000
DS3-EC1-48.EC1-PORT.pmthresholds.sts1.nearend.1day.PPJC-PGEN	5760 (count)	0 - 691200000
DS3-EC1-48.EC1-PORT.pmthresholds.sts1.nearend.1day.SES	7 (seconds)	0 - 86400
DS3-EC1-48.EC1-PORT.pmthresholds.sts1.nearend.1day.UAS	10 (seconds)	0 - 86400

C.2.3.5 DS3E Card Default Settings

Table C-5 lists the DS3E card default settings.

Table C-5 DS3E Card Default Settings

Default Name	Default Value	Default Domain
DS3E.config.AINSSoakTime	08:00 (hours:mins)	00:00, 00:15, 00:30 .. 48:00
DS3E.config.FeInhibitLpbk	FALSE	TRUE, FALSE
DS3E.config.LineLength	0 - 225 ft	0 - 225 ft, 226 - 450 ft
DS3E.config.LineType	UNFRAMED	UNFRAMED, M13, C BIT, AUTO PROVISION FMT
DS3E.config.SDBER	1E-7	1E-5, 1E-6, 1E-7, 1E-8, 1E-9
DS3E.config.SFBER	1E-4	1E-3, 1E-4, 1E-5
DS3E.config.State	IS,AINS	IS, OOS,DSBLD, OOS,MT, IS,AINS
DS3E.pmthresholds.cpbitpath.farend.15min.AISS	10 (seconds)	0 - 86400
DS3E.pmthresholds.cpbitpath.farend.15min.CV	382 (BIP count)	0 - 287100
DS3E.pmthresholds.cpbitpath.farend.15min.ES	25 (seconds)	0 - 900
DS3E.pmthresholds.cpbitpath.farend.15min.SAS	2 (seconds)	0 - 900
DS3E.pmthresholds.cpbitpath.farend.15min.SES	4 (seconds)	0 - 900
DS3E.pmthresholds.cpbitpath.farend.15min.UAS	10 (seconds)	0 - 900
DS3E.pmthresholds.cpbitpath.farend.1day.AISS	10 (seconds)	0 - 86400
DS3E.pmthresholds.cpbitpath.farend.1day.CV	3820 (BIP count)	0 - 27561600
DS3E.pmthresholds.cpbitpath.farend.1day.ES	250 (seconds)	0 - 86400
DS3E.pmthresholds.cpbitpath.farend.1day.SAS	8 (seconds)	0 - 86400
DS3E.pmthresholds.cpbitpath.farend.1day.SES	40 (seconds)	0 - 86400
DS3E.pmthresholds.cpbitpath.farend.1day.UAS	10 (seconds)	0 - 86400

Table C-5 DS3E Card Default Settings (continued)

Default Name	Default Value	Default Domain
DS3E.pmthresholds.cpbitpath.nearend.15min.AISS	10 (seconds)	0 - 900
DS3E.pmthresholds.cpbitpath.nearend.15min.CV	382 (BIP count)	0 - 287100
DS3E.pmthresholds.cpbitpath.nearend.15min.ES	25 (seconds)	0 - 900
DS3E.pmthresholds.cpbitpath.nearend.15min.SAS	2 (seconds)	0 - 900
DS3E.pmthresholds.cpbitpath.nearend.15min.SES	4 (seconds)	0 - 900
DS3E.pmthresholds.cpbitpath.nearend.15min.UAS	10 (seconds)	0 - 900
DS3E.pmthresholds.cpbitpath.nearend.1day.AISS	10 (seconds)	0 - 86400
DS3E.pmthresholds.cpbitpath.nearend.1day.CV	3820 (BIP count)	0 - 27561600
DS3E.pmthresholds.cpbitpath.nearend.1day.ES	250 (seconds)	0 - 86400
DS3E.pmthresholds.cpbitpath.nearend.1day.SAS	8 (seconds)	0 - 86400
DS3E.pmthresholds.cpbitpath.nearend.1day.SES	40 (seconds)	0 - 86400
DS3E.pmthresholds.cpbitpath.nearend.1day.UAS	10 (seconds)	0 - 86400
DS3E.pmthresholds.line.nearend.15min.CV	387 (BPV count)	0 - 38700
DS3E.pmthresholds.line.nearend.15min.ES	25 (seconds)	0 - 900
DS3E.pmthresholds.line.nearend.15min.LOSS	10 (seconds)	0 - 900
DS3E.pmthresholds.line.nearend.15min.SES	4 (seconds)	0 - 900
DS3E.pmthresholds.line.nearend.1day.CV	3865 (BPV count)	0 - 3715200
DS3E.pmthresholds.line.nearend.1day.ES	250 (seconds)	0 - 86400
DS3E.pmthresholds.line.nearend.1day.LOSS	10 (seconds)	0 - 86400
DS3E.pmthresholds.line.nearend.1day.SES	40 (seconds)	0 - 86400
DS3E.pmthresholds.pbitpath.nearend.15min.AISS	10 (seconds)	0 - 900
DS3E.pmthresholds.pbitpath.nearend.15min.CV	382 (BIP count)	0 - 287100
DS3E.pmthresholds.pbitpath.nearend.15min.ES	25 (seconds)	0 - 900
DS3E.pmthresholds.pbitpath.nearend.15min.SAS	2 (seconds)	0 - 900
DS3E.pmthresholds.pbitpath.nearend.15min.SES	4 (seconds)	0 - 900
DS3E.pmthresholds.pbitpath.nearend.15min.UAS	10 (seconds)	0 - 900
DS3E.pmthresholds.pbitpath.nearend.1day.AISS	10 (seconds)	0 - 86400
DS3E.pmthresholds.pbitpath.nearend.1day.CV	3820 (BIP count)	0 - 27561600
DS3E.pmthresholds.pbitpath.nearend.1day.ES	250 (seconds)	0 - 86400
DS3E.pmthresholds.pbitpath.nearend.1day.SAS	8 (seconds)	0 - 86400
DS3E.pmthresholds.pbitpath.nearend.1day.SES	40 (seconds)	0 - 86400
DS3E.pmthresholds.pbitpath.nearend.1day.UAS	10 (seconds)	0 - 86400
DS3E.pmthresholds.sts.farend.15min.CV	15 (G1 count)	0 - 2160000
DS3E.pmthresholds.sts.farend.15min.ES	12 (seconds)	0 - 900
DS3E.pmthresholds.sts.farend.15min.FC	10 (count)	0 - 72
DS3E.pmthresholds.sts.farend.15min.SES	3 (seconds)	0 - 900

Table C-5 DS3E Card Default Settings (continued)

Default Name	Default Value	Default Domain
DS3E.pmthresholds.sts.farend.15min.UAS	10 (seconds)	0 - 900
DS3E.pmthresholds.sts.farend.1day.CV	125 (G1 count)	0 - 207360000
DS3E.pmthresholds.sts.farend.1day.ES	100 (seconds)	0 - 86400
DS3E.pmthresholds.sts.farend.1day.FC	40 (count)	0 - 6912
DS3E.pmthresholds.sts.farend.1day.SES	7 (seconds)	0 - 86400
DS3E.pmthresholds.sts.farend.1day.UAS	10 (seconds)	0 - 86400
DS3E.pmthresholds.sts.nearend.15min.CV	15 (B3 count)	0 - 2160000
DS3E.pmthresholds.sts.nearend.15min.ES	12 (seconds)	0 - 900
DS3E.pmthresholds.sts.nearend.15min.FC	10 (count)	0 - 72
DS3E.pmthresholds.sts.nearend.15min.SES	3 (seconds)	0 - 900
DS3E.pmthresholds.sts.nearend.15min.UAS	10 (seconds)	0 - 900
DS3E.pmthresholds.sts.nearend.1day.CV	125 (B3 count)	0 - 207360000
DS3E.pmthresholds.sts.nearend.1day.ES	100 (seconds)	0 - 86400
DS3E.pmthresholds.sts.nearend.1day.FC	40 (count)	0 - 6912
DS3E.pmthresholds.sts.nearend.1day.SES	7 (seconds)	0 - 86400
DS3E.pmthresholds.sts.nearend.1day.UAS	10 (seconds)	0 - 86400

C.2.3.6 DS3I Card Default Settings

Table C-6 lists the DS3I card default settings.

Table C-6 DS3I Card Default Settings

Default Name	Default Value	Default Domain
DS3I.config.AINSSoakTime	08:00 (hours:mins)	00:00, 00:15, 00:30 .. 48:00
DS3I.config.FeInhibitLpbk	FALSE	TRUE, FALSE
DS3I.config.LineLength	0 - 225 ft	0 - 225 ft, 226 - 450 ft
DS3I.config.LineType	C BIT	UNFRAMED, M13, C BIT, AUTO PROVISION FMT
DS3I.config.SDBER	1E-7	1E-5, 1E-6, 1E-7, 1E-8, 1E-9
DS3I.config.SFBER	1E-4	1E-3, 1E-4, 1E-5
DS3I.config.State	IS,AINS	IS, OOS,DSBLD, OOS,MT, IS,AINS
DS3I.pmthresholds.cpbithpath.farend.15min.CVCP	382 (count)	0 - 287100
DS3I.pmthresholds.cpbithpath.farend.15min.ESCP	25 (seconds)	0 - 900
DS3I.pmthresholds.cpbithpath.farend.15min.SASCP	2 (seconds)	0 - 900
DS3I.pmthresholds.cpbithpath.farend.15min.SESCP	4 (seconds)	0 - 900
DS3I.pmthresholds.cpbithpath.farend.15min.UASCP	10 (seconds)	0 - 900
DS3I.pmthresholds.cpbithpath.farend.1day.CVCP	3820 (count)	0 - 27561600

Table C-6 DS3I Card Default Settings (continued)

Default Name	Default Value	Default Domain
DS3I.pmthresholds.cpbitpath.farend.1day.ESCP	250 (seconds)	0 - 86400
DS3I.pmthresholds.cpbitpath.farend.1day.SASCP	8 (seconds)	0 - 86400
DS3I.pmthresholds.cpbitpath.farend.1day.SESCP	40 (seconds)	0 - 86400
DS3I.pmthresholds.cpbitpath.farend.1day.UASCP	10 (seconds)	0 - 86400
DS3I.pmthresholds.cpbitpath.nearend.15min.CVCP	382 (count)	0 - 287100
DS3I.pmthresholds.cpbitpath.nearend.15min.ESCP	25 (seconds)	0 - 900
DS3I.pmthresholds.cpbitpath.nearend.15min.SESCP	4 (seconds)	0 - 900
DS3I.pmthresholds.cpbitpath.nearend.15min.UASCP	10 (seconds)	0 - 900
DS3I.pmthresholds.cpbitpath.nearend.1day.CVCP	3820 (count)	0 - 27561600
DS3I.pmthresholds.cpbitpath.nearend.1day.ESCP	250 (seconds)	0 - 86400
DS3I.pmthresholds.cpbitpath.nearend.1day.SESCP	40 (seconds)	0 - 86400
DS3I.pmthresholds.cpbitpath.nearend.1day.UASCP	10 (seconds)	0 - 86400
DS3I.pmthresholds.line.nearend.15min.CV	387 (BPV count)	0 - 38700
DS3I.pmthresholds.line.nearend.15min.ES	25 (seconds)	0 - 900
DS3I.pmthresholds.line.nearend.15min.LOSS	10 (seconds)	0 - 900
DS3I.pmthresholds.line.nearend.15min.SES	4 (seconds)	0 - 900
DS3I.pmthresholds.line.nearend.1day.CV	3865 (BPV count)	0 - 3715200
DS3I.pmthresholds.line.nearend.1day.ES	250 (seconds)	0 - 86400
DS3I.pmthresholds.line.nearend.1day.LOSS	10 (seconds)	0 - 86400
DS3I.pmthresholds.line.nearend.1day.SES	40 (seconds)	0 - 86400
DS3I.pmthresholds.pbitpath.nearend.15min.AISSP	10 (seconds)	0 - 900
DS3I.pmthresholds.pbitpath.nearend.15min.CVP	382 (count)	0 - 287100
DS3I.pmthresholds.pbitpath.nearend.15min.ESP	25 (seconds)	0 - 900
DS3I.pmthresholds.pbitpath.nearend.15min.SASP	2 (seconds)	0 - 900
DS3I.pmthresholds.pbitpath.nearend.15min.SESP	4 (seconds)	0 - 900
DS3I.pmthresholds.pbitpath.nearend.15min.UASP	10 (seconds)	0 - 900
DS3I.pmthresholds.pbitpath.nearend.1day.AISSP	10 (seconds)	0 - 86400
DS3I.pmthresholds.pbitpath.nearend.1day.CVP	3820 (count)	0 - 27561600
DS3I.pmthresholds.pbitpath.nearend.1day.ESP	250 (seconds)	0 - 86400
DS3I.pmthresholds.pbitpath.nearend.1day.SASP	8 (seconds)	0 - 86400
DS3I.pmthresholds.pbitpath.nearend.1day.SESP	40 (seconds)	0 - 86400
DS3I.pmthresholds.pbitpath.nearend.1day.UASP	10 (seconds)	0 - 86400
DS3I.pmthresholds.sts.farend.15min.CV	15 (G1 count)	0 - 2160000
DS3I.pmthresholds.sts.farend.15min.ES	12 (seconds)	0 - 900
DS3I.pmthresholds.sts.farend.15min.FC	10 (count)	0 - 72
DS3I.pmthresholds.sts.farend.15min.SES	3 (seconds)	0 - 900

Table C-6 DS3I Card Default Settings (continued)

Default Name	Default Value	Default Domain
DS3I.pmthresholds.sts.farend.15min.UAS	10 (seconds)	0 - 900
DS3I.pmthresholds.sts.farend.1day.CV	125 (G1 count)	0 - 207360000
DS3I.pmthresholds.sts.farend.1day.ES	100 (seconds)	0 - 86400
DS3I.pmthresholds.sts.farend.1day.FC	40 (count)	0 - 6912
DS3I.pmthresholds.sts.farend.1day.SES	7 (seconds)	0 - 86400
DS3I.pmthresholds.sts.farend.1day.UAS	10 (seconds)	0 - 86400
DS3I.pmthresholds.sts.nearend.15min.CV	15 (B3 count)	0 - 2160000
DS3I.pmthresholds.sts.nearend.15min.ES	12 (seconds)	0 - 900
DS3I.pmthresholds.sts.nearend.15min.FC	10 (count)	0 - 72
DS3I.pmthresholds.sts.nearend.15min.SES	3 (seconds)	0 - 900
DS3I.pmthresholds.sts.nearend.15min.UAS	10 (seconds)	0 - 900
DS3I.pmthresholds.sts.nearend.1day.CV	125 (B3 count)	0 - 207360000
DS3I.pmthresholds.sts.nearend.1day.ES	100 (seconds)	0 - 86400
DS3I.pmthresholds.sts.nearend.1day.FC	40 (count)	0 - 6912
DS3I.pmthresholds.sts.nearend.1day.SES	7 (seconds)	0 - 86400
DS3I.pmthresholds.sts.nearend.1day.UAS	10 (seconds)	0 - 86400

C.2.3.7 DS3XM-6 Card Default Settings

Table C-7 lists the DS3XM-6 card default settings.

Table C-7 DS3XM-6 Card Default Settings

Default Name	Default Value	Default Domain
DS3XM.config.AINSSoakTime	08:00 (hours:mins)	00:00, 00:15, 00:30 .. 48:00
DS3XM.config.FeInhibitLpbk	FALSE	TRUE, FALSE
DS3XM.config.LineLength	0 - 225 ft	0 - 225 ft, 226 - 450 ft
DS3XM.config.LineType	M13	M13, C BIT
DS3XM.config.SDBER	1E-7	1E-5, 1E-6, 1E-7, 1E-8, 1E-9
DS3XM.config.SFBER	1E-4	1E-3, 1E-4, 1E-5
DS3XM.config.State	IS,AINS	IS, OOS,DSBLD, OOS,MT, IS,AINS
DS3XM.pmthresholds.cpbithpath.farend.15min.AISS	10 (seconds)	0 - 86400
DS3XM.pmthresholds.cpbithpath.farend.15min.CV	382 (BIP count)	0 - 287100
DS3XM.pmthresholds.cpbithpath.farend.15min.ES	25 (seconds)	0 - 900
DS3XM.pmthresholds.cpbithpath.farend.15min.SAS	2 (seconds)	0 - 900
DS3XM.pmthresholds.cpbithpath.farend.15min.SES	4 (seconds)	0 - 900
DS3XM.pmthresholds.cpbithpath.farend.15min.UAS	10 (seconds)	0 - 900
DS3XM.pmthresholds.cpbithpath.farend.1day.AISS	10 (seconds)	0 - 86400

Table C-7 DS3XM-6 Card Default Settings (continued)

Default Name	Default Value	Default Domain
DS3XM.pmthresholds.cpbitpath.farend.1day.CV	3820 (BIP count)	0 - 27561600
DS3XM.pmthresholds.cpbitpath.farend.1day.ES	250 (seconds)	0 - 86400
DS3XM.pmthresholds.cpbitpath.farend.1day.SAS	8 (seconds)	0 - 86400
DS3XM.pmthresholds.cpbitpath.farend.1day.SES	40 (seconds)	0 - 86400
DS3XM.pmthresholds.cpbitpath.farend.1day.UAS	10 (seconds)	0 - 86400
DS3XM.pmthresholds.cpbitpath.nearend.15min.AISS	10 (seconds)	0 - 900
DS3XM.pmthresholds.cpbitpath.nearend.15min.CV	382 (BIP count)	0 - 287100
DS3XM.pmthresholds.cpbitpath.nearend.15min.ES	25 (seconds)	0 - 900
DS3XM.pmthresholds.cpbitpath.nearend.15min.SAS	2 (seconds)	0 - 900
DS3XM.pmthresholds.cpbitpath.nearend.15min.SES	4 (seconds)	0 - 900
DS3XM.pmthresholds.cpbitpath.nearend.15min.UAS	10 (seconds)	0 - 900
DS3XM.pmthresholds.cpbitpath.nearend.1day.AISS	10 (seconds)	0 - 86400
DS3XM.pmthresholds.cpbitpath.nearend.1day.CV	3820 (BIP count)	0 - 27561600
DS3XM.pmthresholds.cpbitpath.nearend.1day.ES	250 (seconds)	0 - 86400
DS3XM.pmthresholds.cpbitpath.nearend.1day.SAS	8 (seconds)	0 - 86400
DS3XM.pmthresholds.cpbitpath.nearend.1day.SES	40 (seconds)	0 - 86400
DS3XM.pmthresholds.cpbitpath.nearend.1day.UAS	10 (seconds)	0 - 86400
DS3XM.pmthresholds.ds1path.nearend.15min.AISS	10 (seconds)	0 - 900
DS3XM.pmthresholds.ds1path.nearend.15min.ES	65 (seconds)	0 - 900
DS3XM.pmthresholds.ds1path.nearend.15min.SAS	2 (seconds)	0 - 900
DS3XM.pmthresholds.ds1path.nearend.15min.SES	10 (seconds)	0 - 900
DS3XM.pmthresholds.ds1path.nearend.15min.UAS	10 (seconds)	0 - 900
DS3XM.pmthresholds.ds1path.nearend.1day.AISS	10 (seconds)	0 - 86400
DS3XM.pmthresholds.ds1path.nearend.1day.ES	648 (seconds)	0 - 86400
DS3XM.pmthresholds.ds1path.nearend.1day.SAS	17 (seconds)	0 - 86400
DS3XM.pmthresholds.ds1path.nearend.1day.SES	100 (seconds)	0 - 86400
DS3XM.pmthresholds.ds1path.nearend.1day.UAS	10 (seconds)	0 - 86400
DS3XM.pmthresholds.line.nearend.15min.CV	387 (BPV count)	0 - 38700
DS3XM.pmthresholds.line.nearend.15min.ES	25 (seconds)	0 - 900
DS3XM.pmthresholds.line.nearend.15min.LOSS	10 (seconds)	0 - 900
DS3XM.pmthresholds.line.nearend.15min.SES	4 (seconds)	0 - 900
DS3XM.pmthresholds.line.nearend.1day.CV	3865 (BPV count)	0 - 3715200
DS3XM.pmthresholds.line.nearend.1day.ES	250 (seconds)	0 - 86400
DS3XM.pmthresholds.line.nearend.1day.LOSS	10 (seconds)	0 - 86400
DS3XM.pmthresholds.line.nearend.1day.SES	40 (seconds)	0 - 86400
DS3XM.pmthresholds.pbitpath.nearend.15min.AISS	10 (seconds)	0 - 900

Table C-7 DS3XM-6 Card Default Settings (continued)

Default Name	Default Value	Default Domain
DS3XM.pmthresholds.pbitpath.nearend.15min.CV	382 (BIP count)	0 - 287100
DS3XM.pmthresholds.pbitpath.nearend.15min.ES	25 (seconds)	0 - 900
DS3XM.pmthresholds.pbitpath.nearend.15min.SAS	2 (seconds)	0 - 900
DS3XM.pmthresholds.pbitpath.nearend.15min.SES	4 (seconds)	0 - 900
DS3XM.pmthresholds.pbitpath.nearend.15min.UAS	10 (seconds)	0 - 900
DS3XM.pmthresholds.pbitpath.nearend.1day.AISS	10 (seconds)	0 - 86400
DS3XM.pmthresholds.pbitpath.nearend.1day.CV	3820 (BIP count)	0 - 27561600
DS3XM.pmthresholds.pbitpath.nearend.1day.ES	250 (seconds)	0 - 86400
DS3XM.pmthresholds.pbitpath.nearend.1day.SAS	8 (seconds)	0 - 86400
DS3XM.pmthresholds.pbitpath.nearend.1day.SES	40 (seconds)	0 - 86400
DS3XM.pmthresholds.pbitpath.nearend.1day.UAS	10 (seconds)	0 - 86400
DS3XM.pmthresholds.sts.farend.15min.CV	15 (B3 count)	0 - 2160000
DS3XM.pmthresholds.sts.farend.15min.ES	12 (seconds)	0 - 900
DS3XM.pmthresholds.sts.farend.15min.FC	10 (count)	0 - 72
DS3XM.pmthresholds.sts.farend.15min.SES	3 (seconds)	0 - 900
DS3XM.pmthresholds.sts.farend.15min.UAS	10 (seconds)	0 - 900
DS3XM.pmthresholds.sts.farend.1day.CV	125 (B3 count)	0 - 207360000
DS3XM.pmthresholds.sts.farend.1day.ES	100 (seconds)	0 - 86400
DS3XM.pmthresholds.sts.farend.1day.FC	40 (count)	0 - 6912
DS3XM.pmthresholds.sts.farend.1day.SES	7 (seconds)	0 - 86400
DS3XM.pmthresholds.sts.farend.1day.UAS	10 (seconds)	0 - 86400
DS3XM.pmthresholds.sts.nearend.15min.CV	15 (B3 count)	0 - 2160000
DS3XM.pmthresholds.sts.nearend.15min.ES	12 (seconds)	0 - 900
DS3XM.pmthresholds.sts.nearend.15min.FC	10 (count)	0 - 72
DS3XM.pmthresholds.sts.nearend.15min.SES	3 (seconds)	0 - 900
DS3XM.pmthresholds.sts.nearend.15min.UAS	10 (seconds)	0 - 900
DS3XM.pmthresholds.sts.nearend.1day.CV	125 (B3 count)	0 - 207360000
DS3XM.pmthresholds.sts.nearend.1day.ES	100 (seconds)	0 - 86400
DS3XM.pmthresholds.sts.nearend.1day.FC	40 (count)	0 - 6912
DS3XM.pmthresholds.sts.nearend.1day.SES	7 (seconds)	0 - 86400
DS3XM.pmthresholds.sts.nearend.1day.UAS	10 (seconds)	0 - 86400
DS3XM.pmthresholds.vt.farend.15min.CV	15 (BIP8 count)	0 - 2160000
DS3XM.pmthresholds.vt.farend.15min.ES	12 (seconds)	0 - 900
DS3XM.pmthresholds.vt.farend.15min.SES	3 (seconds)	0 - 900
DS3XM.pmthresholds.vt.farend.15min.UAS	10 (seconds)	0 - 900
DS3XM.pmthresholds.vt.farend.1day.CV	125 (BIP8 count)	0 - 207360000

Table C-7 DS3XM-6 Card Default Settings (continued)

Default Name	Default Value	Default Domain
DS3XM.pmthresholds.vt.farend.1day.ES	100 (seconds)	0 - 86400
DS3XM.pmthresholds.vt.farend.1day.SES	7 (seconds)	0 - 86400
DS3XM.pmthresholds.vt.farend.1day.UAS	10 (seconds)	0 - 86400
DS3XM.pmthresholds.vt.nearend.15min.CV	15 (BIP8 count)	0 - 2160000
DS3XM.pmthresholds.vt.nearend.15min.ES	12 (seconds)	0 - 900
DS3XM.pmthresholds.vt.nearend.15min.SES	3 (seconds)	0 - 900
DS3XM.pmthresholds.vt.nearend.15min.UAS	10 (seconds)	0 - 900
DS3XM.pmthresholds.vt.nearend.1day.CV	125 (BIP8 count)	0 - 207360000
DS3XM.pmthresholds.vt.nearend.1day.ES	100 (seconds)	0 - 86400
DS3XM.pmthresholds.vt.nearend.1day.SES	7 (seconds)	0 - 86400
DS3XM.pmthresholds.vt.nearend.1day.UAS	10 (seconds)	0 - 86400

C.2.3.8 DS3XM-12 Card Default Settings

Table C-8 lists the DS3XM-12 card default settings.

Table C-8 DS3XM-12 Card Default Settings

Default Name	Default Value	Default Domain
DS3XM12.config.AINSSoakTime	08:00 (hours:mins)	00:00, 00:15, 00:30 .. 48:00
DS3XM12.config.FeInhibitLpbk	FALSE	TRUE, FALSE
DS3XM12.config.LineLength	0 - 225 ft (feet)	0 - 225 ft, 226 - 450 ft
DS3XM12.config.LineType	M13	M13, C BIT
DS3XM12.config.SDBER	1E-7	1E-5, 1E-6, 1E-7, 1E-8, 1E-9
DS3XM12.config.SFBER	1E-4	1E-3, 1E-4, 1E-5
DS3XM12.config.State	OOS,DSBLD	IS, OOS,DSBLD, OOS,MT, IS,AINS
DS3XM12.ds1config.FdlMode	T1.403	T1.403, BFDL when LineType ESF, D4; T1.403 when LineType UNFRAMED, AUTO FRAME
DS3XM12.ds1config.LineType	AUTO FRAME	ESF, D4, UNFRAMED, AUTO FRAME
DS3XM12.pmthresholds.cpbitpath.farend.15min.AISS	10 (seconds)	0 - 86400
DS3XM12.pmthresholds.cpbitpath.farend.15min.CV	382 (BIP count)	0 - 287100
DS3XM12.pmthresholds.cpbitpath.farend.15min.ES	25 (seconds)	0 - 900
DS3XM12.pmthresholds.cpbitpath.farend.15min.SAS	2 (seconds)	0 - 900
DS3XM12.pmthresholds.cpbitpath.farend.15min.SES	4 (seconds)	0 - 900
DS3XM12.pmthresholds.cpbitpath.farend.15min.UAS	10 (seconds)	0 - 900
DS3XM12.pmthresholds.cpbitpath.farend.1day.AISS	10 (seconds)	0 - 86400
DS3XM12.pmthresholds.cpbitpath.farend.1day.CV	3820 (BIP count)	0 - 27561600

Table C-8 DS3XM-12 Card Default Settings (continued)

Default Name	Default Value	Default Domain
DS3XM12.pmthresholds.cpbitpath.farend.1day.ES	250 (seconds)	0 - 86400
DS3XM12.pmthresholds.cpbitpath.farend.1day.SAS	8 (seconds)	0 - 86400
DS3XM12.pmthresholds.cpbitpath.farend.1day.SES	40 (seconds)	0 - 86400
DS3XM12.pmthresholds.cpbitpath.farend.1day.UAS	10 (seconds)	0 - 86400
DS3XM12.pmthresholds.cpbitpath.nearend.15min.AISS	10 (seconds)	0 - 900
DS3XM12.pmthresholds.cpbitpath.nearend.15min.CV	382 (BIP count)	0 - 287100
DS3XM12.pmthresholds.cpbitpath.nearend.15min.ES	25 (seconds)	0 - 900
DS3XM12.pmthresholds.cpbitpath.nearend.15min.SAS	2 (seconds)	0 - 900
DS3XM12.pmthresholds.cpbitpath.nearend.15min.SES	4 (seconds)	0 - 900
DS3XM12.pmthresholds.cpbitpath.nearend.15min.UAS	10 (seconds)	0 - 900
DS3XM12.pmthresholds.cpbitpath.nearend.1day.AISS	10 (seconds)	0 - 86400
DS3XM12.pmthresholds.cpbitpath.nearend.1day.CV	3820 (BIP count)	0 - 27561600
DS3XM12.pmthresholds.cpbitpath.nearend.1day.ES	250 (seconds)	0 - 86400
DS3XM12.pmthresholds.cpbitpath.nearend.1day.SAS	8 (seconds)	0 - 86400
DS3XM12.pmthresholds.cpbitpath.nearend.1day.SES	40 (seconds)	0 - 86400
DS3XM12.pmthresholds.cpbitpath.nearend.1day.UAS	10 (seconds)	0 - 86400
DS3XM12.pmthresholds.ds1network.farend.15min.ESFE	65 (seconds)	0 - 900
DS3XM12.pmthresholds.ds1network.farend.15min.ESNE	65 (seconds)	0 - 900
DS3XM12.pmthresholds.ds1network.farend.15min.SESFE	10 (seconds)	0 - 900
DS3XM12.pmthresholds.ds1network.farend.15min.SESNE	10 (seconds)	0 - 900
DS3XM12.pmthresholds.ds1network.farend.15min.UASFE	10 (seconds)	0 - 900
DS3XM12.pmthresholds.ds1network.farend.15min.UASNE	10 (seconds)	0 - 900
DS3XM12.pmthresholds.ds1network.farend.1day.ESFE	648 (seconds)	0 - 86400
DS3XM12.pmthresholds.ds1network.farend.1day.ESNE	648 (seconds)	0 - 86400
DS3XM12.pmthresholds.ds1network.farend.1day.SESFE	100 (seconds)	0 - 86400
DS3XM12.pmthresholds.ds1network.farend.1day.SESNE	100 (seconds)	0 - 86400
DS3XM12.pmthresholds.ds1network.farend.1day.UASFE	10 (seconds)	0 - 86400
DS3XM12.pmthresholds.ds1network.farend.1day.UASNE	10 (seconds)	0 - 86400
DS3XM12.pmthresholds.ds1path.farend.15min.AISS	10 (seconds)	0 - 900
DS3XM12.pmthresholds.ds1path.farend.15min.CSS	25 (seconds)	0 - 900
DS3XM12.pmthresholds.ds1path.farend.15min.CV	13296 (count)	0 - 287100
DS3XM12.pmthresholds.ds1path.farend.15min.ES	65 (seconds)	0 - 900
DS3XM12.pmthresholds.ds1path.farend.15min.ESA	25 (seconds)	0 - 900
DS3XM12.pmthresholds.ds1path.farend.15min.ESB	25 (seconds)	0 - 900
DS3XM12.pmthresholds.ds1path.farend.15min.SEFS	25 (seconds)	0 - 900
DS3XM12.pmthresholds.ds1path.farend.15min.SES	10 (seconds)	0 - 900

Table C-8 DS3XM-12 Card Default Settings (continued)

Default Name	Default Value	Default Domain
DS3XM12.pmthresholds.ds1path.farend.15min.UAS	10 (seconds)	0 - 900
DS3XM12.pmthresholds.ds1path.farend.1day.AISS	10 (seconds)	0 - 86400
DS3XM12.pmthresholds.ds1path.farend.1day.CSS	25 (seconds)	0 - 86400
DS3XM12.pmthresholds.ds1path.farend.1day.CV	132960 (count)	0 - 27561600
DS3XM12.pmthresholds.ds1path.farend.1day.ES	648 (seconds)	0 - 86400
DS3XM12.pmthresholds.ds1path.farend.1day.ESA	25 (seconds)	0 - 86400
DS3XM12.pmthresholds.ds1path.farend.1day.ESB	25 (seconds)	0 - 86400
DS3XM12.pmthresholds.ds1path.farend.1day.SEFS	25 (seconds)	0 - 86400
DS3XM12.pmthresholds.ds1path.farend.1day.SES	100 (seconds)	0 - 86400
DS3XM12.pmthresholds.ds1path.farend.1day.UAS	10 (seconds)	0 - 86400
DS3XM12.pmthresholds.ds1path.nearend.15min.AISS	10 (seconds)	0 - 900
DS3XM12.pmthresholds.ds1path.nearend.15min.CV	13296 (count)	0 - 287100
DS3XM12.pmthresholds.ds1path.nearend.15min.ES	65 (seconds)	0 - 900
DS3XM12.pmthresholds.ds1path.nearend.15min.FC	10 (seconds)	0 - 900
DS3XM12.pmthresholds.ds1path.nearend.15min.SAS	2 (seconds)	0 - 900
DS3XM12.pmthresholds.ds1path.nearend.15min.SES	10 (seconds)	0 - 900
DS3XM12.pmthresholds.ds1path.nearend.15min.UAS	10 (seconds)	0 - 900
DS3XM12.pmthresholds.ds1path.nearend.1day.AISS	10 (seconds)	0 - 86400
DS3XM12.pmthresholds.ds1path.nearend.1day.CV	132960 (count)	0 - 27561600
DS3XM12.pmthresholds.ds1path.nearend.1day.ES	648 (seconds)	0 - 86400
DS3XM12.pmthresholds.ds1path.nearend.1day.FC	40 (seconds)	0 - 86400
DS3XM12.pmthresholds.ds1path.nearend.1day.SAS	17 (seconds)	0 - 86400
DS3XM12.pmthresholds.ds1path.nearend.1day.SES	100 (seconds)	0 - 86400
DS3XM12.pmthresholds.ds1path.nearend.1day.UAS	10 (seconds)	0 - 86400
DS3XM12.pmthresholds.line.nearend.15min.CV	387 (BPV count)	0 - 38700
DS3XM12.pmthresholds.line.nearend.15min.ES	25 (seconds)	0 - 900
DS3XM12.pmthresholds.line.nearend.15min.LOSS	10 (seconds)	0 - 900
DS3XM12.pmthresholds.line.nearend.15min.SES	4 (seconds)	0 - 900
DS3XM12.pmthresholds.line.nearend.1day.CV	3865 (BPV count)	0 - 3715200
DS3XM12.pmthresholds.line.nearend.1day.ES	250 (seconds)	0 - 86400
DS3XM12.pmthresholds.line.nearend.1day.LOSS	10 (seconds)	0 - 86400
DS3XM12.pmthresholds.line.nearend.1day.SES	40 (seconds)	0 - 86400
DS3XM12.pmthresholds.pbitpath.nearend.15min.AISS	10 (seconds)	0 - 900
DS3XM12.pmthresholds.pbitpath.nearend.15min.CV	382 (BIP count)	0 - 287100
DS3XM12.pmthresholds.pbitpath.nearend.15min.ES	25 (seconds)	0 - 900
DS3XM12.pmthresholds.pbitpath.nearend.15min.SAS	2 (seconds)	0 - 900

Table C-8 DS3XM-12 Card Default Settings (continued)

Default Name	Default Value	Default Domain
DS3XM12.pmthresholds.pbitpath.nearend.15min.SES	4 (seconds)	0 - 900
DS3XM12.pmthresholds.pbitpath.nearend.15min.UAS	10 (seconds)	0 - 900
DS3XM12.pmthresholds.pbitpath.nearend.1day.AISS	10 (seconds)	0 - 86400
DS3XM12.pmthresholds.pbitpath.nearend.1day.CV	3820 (BIP count)	0 - 27561600
DS3XM12.pmthresholds.pbitpath.nearend.1day.ES	250 (seconds)	0 - 86400
DS3XM12.pmthresholds.pbitpath.nearend.1day.SAS	8 (seconds)	0 - 86400
DS3XM12.pmthresholds.pbitpath.nearend.1day.SES	40 (seconds)	0 - 86400
DS3XM12.pmthresholds.pbitpath.nearend.1day.UAS	10 (seconds)	0 - 86400
DS3XM12.pmthresholds.sts.farend.15min.CV	15 (B3 count)	0 - 2160000
DS3XM12.pmthresholds.sts.farend.15min.ES	12 (seconds)	0 - 900
DS3XM12.pmthresholds.sts.farend.15min.FC	10 (count)	0 - 72
DS3XM12.pmthresholds.sts.farend.15min.SES	3 (seconds)	0 - 900
DS3XM12.pmthresholds.sts.farend.15min.UAS	10 (seconds)	0 - 900
DS3XM12.pmthresholds.sts.farend.1day.CV	125 (B3 count)	0 - 207360000
DS3XM12.pmthresholds.sts.farend.1day.ES	100 (seconds)	0 - 86400
DS3XM12.pmthresholds.sts.farend.1day.FC	40 (count)	0 - 6912
DS3XM12.pmthresholds.sts.farend.1day.SES	7 (seconds)	0 - 86400
DS3XM12.pmthresholds.sts.farend.1day.UAS	10 (seconds)	0 - 86400
DS3XM12.pmthresholds.sts.nearend.15min.CV	15 (B3 count)	0 - 2160000
DS3XM12.pmthresholds.sts.nearend.15min.ES	12 (seconds)	0 - 900
DS3XM12.pmthresholds.sts.nearend.15min.FC	10 (count)	0 - 72
DS3XM12.pmthresholds.sts.nearend.15min.SES	3 (seconds)	0 - 900
DS3XM12.pmthresholds.sts.nearend.15min.UAS	10 (seconds)	0 - 900
DS3XM12.pmthresholds.sts.nearend.1day.CV	125 (B3 count)	0 - 207360000
DS3XM12.pmthresholds.sts.nearend.1day.ES	100 (seconds)	0 - 86400
DS3XM12.pmthresholds.sts.nearend.1day.FC	40 (count)	0 - 6912
DS3XM12.pmthresholds.sts.nearend.1day.SES	7 (seconds)	0 - 86400
DS3XM12.pmthresholds.sts.nearend.1day.UAS	10 (seconds)	0 - 86400
DS3XM12.pmthresholds.vt.farend.15min.CV	15 (BIP8 count)	0 - 2160000
DS3XM12.pmthresholds.vt.farend.15min.ES	12 (seconds)	0 - 900
DS3XM12.pmthresholds.vt.farend.15min.SES	3 (seconds)	0 - 900
DS3XM12.pmthresholds.vt.farend.15min.UAS	10 (seconds)	0 - 900
DS3XM12.pmthresholds.vt.farend.1day.CV	125 (BIP8 count)	0 - 207360000
DS3XM12.pmthresholds.vt.farend.1day.ES	100 (seconds)	0 - 86400
DS3XM12.pmthresholds.vt.farend.1day.SES	7 (seconds)	0 - 86400
DS3XM12.pmthresholds.vt.farend.1day.UAS	10 (seconds)	0 - 86400

Table C-8 DS3XM-12 Card Default Settings (continued)

Default Name	Default Value	Default Domain
DS3XM12.pmthresholds.vt.nearend.15min.CV	15 (BIP8 count)	0 - 2160000
DS3XM12.pmthresholds.vt.nearend.15min.ES	12 (seconds)	0 - 900
DS3XM12.pmthresholds.vt.nearend.15min.SES	3 (seconds)	0 - 900
DS3XM12.pmthresholds.vt.nearend.15min.UAS	10 (seconds)	0 - 900
DS3XM12.pmthresholds.vt.nearend.1day.CV	125 (BIP8 count)	0 - 207360000
DS3XM12.pmthresholds.vt.nearend.1day.ES	100 (seconds)	0 - 86400
DS3XM12.pmthresholds.vt.nearend.1day.SES	7 (seconds)	0 - 86400
DS3XM12.pmthresholds.vt.nearend.1day.UAS	10 (seconds)	0 - 86400

C.2.3.9 EC1-12 Card Default Settings

Table C-9 lists the EC1-12 card default settings.

Table C-9 EC1-12 Card Default Settings

Default Name	Default Value	Default Domain
EC1.config.line.AINSSoakTime	08:00 (hours:mins)	00:00, 00:15, 00:30 .. 48:00
EC1.config.line.LineLength	0 - 225 ft	0 - 225 ft, 226 - 450 ft
EC1.config.line.PJStsMon#	0 (STS #)	0 - 1
EC1.config.line.RxEqualization	TRUE	TRUE, FALSE
EC1.config.line.SDBER	1E-7	1E-5, 1E-6, 1E-7, 1E-8, 1E-9
EC1.config.line.SFBER	1E-4	1E-3, 1E-4, 1E-5
EC1.config.line.State	IS,AINS	IS, OOS,DSBLD, OOS,MT, IS,AINS
EC1.config.sts.IPPMEnabled	FALSE	TRUE, FALSE
EC1.pmthresholds.line.farend.15min.CV	1312 (B2 count)	0 - 137700
EC1.pmthresholds.line.farend.15min.ES	87 (seconds)	0 - 900
EC1.pmthresholds.line.farend.15min.FC	10 (count)	0 - 72
EC1.pmthresholds.line.farend.15min.SES	1 (seconds)	0 - 900
EC1.pmthresholds.line.farend.15min.UAS	3 (seconds)	0 - 900
EC1.pmthresholds.line.farend.1day.CV	13120 (B2 count)	0 - 8850600
EC1.pmthresholds.line.farend.1day.ES	864 (seconds)	0 - 86400
EC1.pmthresholds.line.farend.1day.FC	40 (count)	0 - 72
EC1.pmthresholds.line.farend.1day.SES	4 (seconds)	0 - 86400
EC1.pmthresholds.line.farend.1day.UAS	10 (seconds)	0 - 86400
EC1.pmthresholds.line.nearend.15min.CV	1312 (B2 count)	0 - 137700
EC1.pmthresholds.line.nearend.15min.ES	87 (seconds)	0 - 900
EC1.pmthresholds.line.nearend.15min.FC	10 (count)	0 - 72
EC1.pmthresholds.line.nearend.15min.SES	1 (seconds)	0 - 900

Table C-9 EC1-12 Card Default Settings (continued)

Default Name	Default Value	Default Domain
EC1.pmthresholds.line.nearend.15min.UAS	3 (seconds)	0 - 900
EC1.pmthresholds.line.nearend.1day.CV	13120 (B2 count)	0 - 13219200
EC1.pmthresholds.line.nearend.1day.ES	864 (seconds)	0 - 86400
EC1.pmthresholds.line.nearend.1day.FC	40 (count)	0 - 6912
EC1.pmthresholds.line.nearend.1day.SES	4 (seconds)	0 - 86400
EC1.pmthresholds.line.nearend.1day.UAS	10 (seconds)	0 - 86400
EC1.pmthresholds.section.nearend.15min.CV	10000 (B1 count)	0 - 138600
EC1.pmthresholds.section.nearend.15min.ES	500 (seconds)	0 - 900
EC1.pmthresholds.section.nearend.15min.SEFS	500 (seconds)	0 - 900
EC1.pmthresholds.section.nearend.15min.SES	500 (seconds)	0 - 900
EC1.pmthresholds.section.nearend.1day.CV	100000 (B1 count)	0 - 13305600
EC1.pmthresholds.section.nearend.1day.ES	5000 (seconds)	0 - 86400
EC1.pmthresholds.section.nearend.1day.SEFS	5000 (seconds)	0 - 86400
EC1.pmthresholds.section.nearend.1day.SES	5000 (seconds)	0 - 86400
EC1.pmthresholds.sts1.nearend.15min.CV	15 (B3 count)	0 - 2160000
EC1.pmthresholds.sts1.nearend.15min.ES	12 (seconds)	0 - 900
EC1.pmthresholds.sts1.nearend.15min.FC	10 (count)	0 - 72
EC1.pmthresholds.sts1.nearend.15min.NPJC-PDET	60 (count)	0 - 7200000
EC1.pmthresholds.sts1.nearend.15min.NPJC-PGEN	60 (count)	0 - 7200000
EC1.pmthresholds.sts1.nearend.15min.PJCDIFF	60 (count)	0 - 14400000
EC1.pmthresholds.sts1.nearend.15min.PJCS-PDET	100 (seconds)	0 - 900
EC1.pmthresholds.sts1.nearend.15min.PJCS-PGEN	100 (seconds)	0 - 900
EC1.pmthresholds.sts1.nearend.15min.PPJC-PDET	60 (count)	0 - 7200000
EC1.pmthresholds.sts1.nearend.15min.PPJC-PGEN	60 (count)	0 - 7200000
EC1.pmthresholds.sts1.nearend.15min.SES	3 (seconds)	0 - 900
EC1.pmthresholds.sts1.nearend.15min.UAS	10 (seconds)	0 - 900
EC1.pmthresholds.sts1.nearend.1day.CV	125 (B3 count)	0 - 207360000
EC1.pmthresholds.sts1.nearend.1day.ES	100 (seconds)	0 - 86400
EC1.pmthresholds.sts1.nearend.1day.FC	40 (count)	0 - 6912
EC1.pmthresholds.sts1.nearend.1day.NPJC-PDET	5760 (count)	0 - 691200000
EC1.pmthresholds.sts1.nearend.1day.NPJC-PGEN	5760 (count)	0 - 691200000
EC1.pmthresholds.sts1.nearend.1day.PJCDIFF	5760 (count)	0 - 1382400000
EC1.pmthresholds.sts1.nearend.1day.PJCS-PDET	9600 (seconds)	0 - 86400
EC1.pmthresholds.sts1.nearend.1day.PJCS-PGEN	9600 (seconds)	0 - 86400
EC1.pmthresholds.sts1.nearend.1day.PPJC-PDET	5760 (count)	0 - 691200000
EC1.pmthresholds.sts1.nearend.1day.PPJC-PGEN	5760 (count)	0 - 691200000

Table C-9 EC1-12 Card Default Settings (continued)

Default Name	Default Value	Default Domain
EC1.pmthresholds.sts1.nearend.1day.SES	7 (seconds)	0 - 86400
EC1.pmthresholds.sts1.nearend.1day.UAS	10 (seconds)	0 - 86400

C.2.3.10 FC_MR-4 Card Default Settings

Table C-10 lists the FC_MR-4 card default settings.

Table C-10 FC_MR-4 Card Default Settings

Default Name	Default Value	Default Domain
FC-MR.config.card.Mode	Fibre Channel/FICON Enhanced	Fibre Channel Line Rate, Fibre Channel/FICON Enhanced when //port.MediaType Undefined; Fibre Channel/FICON Enhanced when //port.MediaType FICON - 1 Gbps ISL, FICON - 2 Gbps ISL; Fibre Channel Line Rate, Fibre Channel/FICON Enhanced when //port.MediaType Fibre Channel - 1 Gbps ISL, Fibre Channel - 2 Gbps ISL
FC-MR.config.port.AINSSoakTime	08:00 (hours:mins)	00:00, 00:15, 00:30 .. 48:00
FC-MR.config.port.distanceExtension.AutoadjustGFPBufferThreshold	TRUE	TRUE, FALSE
FC-MR.config.port.distanceExtension.AutoDetect	TRUE	TRUE, FALSE
FC-MR.config.port.distanceExtension.NumCredits	32	2 - 256
FC-MR.config.port.distanceExtension.NumGFPBuffers	16	16, 32, 48 .. 1200
FC-MR.config.port.DistanceExtensionVsLinkRecovery	Distance Extension	Neither Distance Extension nor Link Recovery, Distance Extension, LinkRecovery when MediaType Undefined; Distance Extension when MediaType FICON - 1 Gbps ISL, FICON - 2 Gbps ISL; Neither Distance Extension nor Link Recovery, Distance Extension, LinkRecovery when MediaType Fibre Channel - 1 Gbps ISL, Fibre Channel - 2 Gbps ISL
FC-MR.config.port.enhancedFibreChannelFicon.IngressIdleFiltering	TRUE	TRUE, FALSE
FC-MR.config.port.enhancedFibreChannelFicon.MaxFrameSize	2148	2148, 2152, 2156, 2160, 2164, 2168, 2172

Table C-10 FC_MR-4 Card Default Settings (continued)

Default Name	Default Value	Default Domain
FC-MR.config.port.MediaType	Undefined	Fibre Channel - 1 Gbps ISL, Fibre Channel - 2 Gbps ISL, FICON - 1 Gbps ISL, FICON - 2 Gbps ISL, Undefined
FC-MR.config.port.State	OOS,DSBLD	IS, OOS,DSBLD, OOS,MT, IS,AINS

C.2.3.11 Ethernet Card Default Settings

Table C-11 lists the G1000 (G1K-4), ML1000, ML100T, ML-100X-8, and CE-100T-8 card default settings.

Table C-11 Ethernet Card Default Settings

Default Name	Default Value	Default Domain
CE-1000-4.config.AINSSoakTime	08:00 (hours:mins)	00:00, 00:15, 00:30 .. 48:00
CE-1000-4.config.State	OOS,DSBLD	IS, OOS,DSBLD, OOS,MT, IS,AINS
CE-1000-4.etherPortConfig.AutoNegotiation	TRUE	TRUE, FALSE
CE-1000-4.etherPortConfig.FlowControl	Symmetric	None, Symmetric, Pass Through
CE-1000-4.etherPortConfig.MTU	10004 (bytes)	1548, 10004
CE-1000-4.posPortConfig.FramingType	GFP-F	HDLC, GFP-F
CE-100T-8.config.AINSSoakTime	08:00 (hours:mins)	00:00, 00:15, 00:30 .. 48:00
CE-100T-8.config.State	OOS,DSBLD	IS, OOS,DSBLD, OOS,MT, IS,AINS
CE-100T-8.etherPortConfig.802-1Q-VlanCoS	7 (count)	0 - 7
CE-100T-8.etherPortConfig.IP-ToS	255 (count)	0 - 255
G1000.config.AINSSoakTime	08:00 (hours:mins)	00:00, 00:15, 00:30 .. 48:00
G1000.config.State	OOS,DSBLD	IS, OOS,DSBLD, OOS,MT, IS,AINS
ML1000.config.card.Mode	HDLC	HDLC, GFP-F
ML1000.ios.consolePortAccess	TRUE	TRUE, FALSE
ML1000.ios.radiusServerAccess	FALSE	TRUE, FALSE
ML100T.config.card.Mode	HDLC	HDLC, GFP-F
ML100T.ios.consolePortAccess	TRUE	TRUE, FALSE
ML100T.ios.radiusServerAccess	FALSE	TRUE, FALSE
ML100X-8.config.card.Mode	HDLC	HDLC, GFP-F
ML100X-8.ios.consolePortAccess	TRUE	TRUE, FALSE
ML100X-8.ios.radiusServerAccess	FALSE	TRUE, FALSE

C.2.3.12 OC-3 Card Default Settings

Table C-12 lists the OC-3 (OC3 IR 4/STM1 SH 1310) card default settings.

Table C-12 OC-3 Card Default Settings

Default Name	Default Value	Default Domain
OC3.config.line.AdminSSMIn	STU	PRS, STU, ST2, TNC, ST3E, ST3, SMC, ST4, DUS, RES
OC3.config.line.AINSSoakTime	08:00 (hours:mins)	00:00, 00:15, 00:30 .. 48:00
OC3.config.line.PJStsMon#	0 (STS #)	0 - 3
OC3.config.line.SDBER	1E-7	1E-5, 1E-6, 1E-7, 1E-8, 1E-9
OC3.config.line.Send<FF>DoNotUse	FALSE	FALSE when SendDoNotUse TRUE; FALSE, TRUE when SendDoNotUse FALSE
OC3.config.line.SendDoNotUse	FALSE	FALSE, TRUE
OC3.config.line.SFBER	1E-4	1E-3, 1E-4, 1E-5
OC3.config.line.State	IS,AINS	IS, OOS,DSBLD, OOS,MT, IS,AINS
OC3.config.line.SyncMsgIn	TRUE	FALSE, TRUE
OC3.config.sts.IPPMEnabled	FALSE	TRUE, FALSE
OC3.pmthresholds.line.farend.15min.CV	1312 (B2 count)	0 - 137700
OC3.pmthresholds.line.farend.15min.ES	87 (seconds)	0 - 900
OC3.pmthresholds.line.farend.15min.FC	10 (count)	0 - 72
OC3.pmthresholds.line.farend.15min.SES	1 (seconds)	0 - 900
OC3.pmthresholds.line.farend.15min.UAS	3 (seconds)	0 - 900
OC3.pmthresholds.line.farend.1day.CV	13120 (B2 count)	0 - 13219200
OC3.pmthresholds.line.farend.1day.ES	864 (seconds)	0 - 86400
OC3.pmthresholds.line.farend.1day.FC	40 (count)	0 - 6912
OC3.pmthresholds.line.farend.1day.SES	4 (seconds)	0 - 86400
OC3.pmthresholds.line.farend.1day.UAS	10 (seconds)	0 - 86400
OC3.pmthresholds.line.nearend.15min.CV	1312 (B2 count)	0 - 137700
OC3.pmthresholds.line.nearend.15min.ES	87 (seconds)	0 - 900
OC3.pmthresholds.line.nearend.15min.FC	10 (count)	0 - 72
OC3.pmthresholds.line.nearend.15min.PSC	1 (count)	0 - 600
OC3.pmthresholds.line.nearend.15min.PSD	300 (seconds)	0 - 900
OC3.pmthresholds.line.nearend.15min.SES	1 (seconds)	0 - 900
OC3.pmthresholds.line.nearend.15min.UAS	3 (seconds)	0 - 900
OC3.pmthresholds.line.nearend.1day.CV	13120 (B2 count)	0 - 13219200
OC3.pmthresholds.line.nearend.1day.ES	864 (seconds)	0 - 86400
OC3.pmthresholds.line.nearend.1day.FC	40 (count)	0 - 6912
OC3.pmthresholds.line.nearend.1day.PSC	5 (count)	0 - 57600
OC3.pmthresholds.line.nearend.1day.PSD	600 (seconds)	0 - 86400
OC3.pmthresholds.line.nearend.1day.SES	4 (seconds)	0 - 86400
OC3.pmthresholds.line.nearend.1day.UAS	10 (seconds)	0 - 86400

Table C-12 OC-3 Card Default Settings (continued)

Default Name	Default Value	Default Domain
OC3.pmthresholds.section.nearend.15min.CV	10000 (B1 count)	0 - 138600
OC3.pmthresholds.section.nearend.15min.ES	500 (seconds)	0 - 900
OC3.pmthresholds.section.nearend.15min.SEFS	500 (seconds)	0 - 900
OC3.pmthresholds.section.nearend.15min.SES	500 (seconds)	0 - 900
OC3.pmthresholds.section.nearend.1day.CV	100000 (B1 count)	0 - 13305600
OC3.pmthresholds.section.nearend.1day.ES	5000 (seconds)	0 - 86400
OC3.pmthresholds.section.nearend.1day.SEFS	5000 (seconds)	0 - 86400
OC3.pmthresholds.section.nearend.1day.SES	5000 (seconds)	0 - 86400
OC3.pmthresholds.sts1.nearend.15min.CV	15 (B3 count)	0 - 2160000
OC3.pmthresholds.sts1.nearend.15min.ES	12 (seconds)	0 - 900
OC3.pmthresholds.sts1.nearend.15min.FC	10 (count)	0 - 72
OC3.pmthresholds.sts1.nearend.15min.NPJC-PDET	60 (count)	0 - 7200000
OC3.pmthresholds.sts1.nearend.15min.NPJC-PGEN	60 (count)	0 - 7200000
OC3.pmthresholds.sts1.nearend.15min.PJCDIFF	60 (count)	0 - 14400000
OC3.pmthresholds.sts1.nearend.15min.PJCS-PDET	100 (seconds)	0 - 900
OC3.pmthresholds.sts1.nearend.15min.PJCS-PGEN	100 (seconds)	0 - 900
OC3.pmthresholds.sts1.nearend.15min.PPJC-PDET	60 (count)	0 - 7200000
OC3.pmthresholds.sts1.nearend.15min.PPJC-PGEN	60 (count)	0 - 7200000
OC3.pmthresholds.sts1.nearend.15min.SES	3 (seconds)	0 - 900
OC3.pmthresholds.sts1.nearend.15min.UAS	10 (seconds)	0 - 900
OC3.pmthresholds.sts1.nearend.1day.CV	125 (B3 count)	0 - 207360000
OC3.pmthresholds.sts1.nearend.1day.ES	100 (seconds)	0 - 86400
OC3.pmthresholds.sts1.nearend.1day.FC	40 (count)	0 - 6912
OC3.pmthresholds.sts1.nearend.1day.NPJC-PDET	5760 (count)	0 - 691200000
OC3.pmthresholds.sts1.nearend.1day.NPJC-PGEN	5760 (count)	0 - 691200000
OC3.pmthresholds.sts1.nearend.1day.PJCDIFF	5760 (count)	0 - 1382400000
OC3.pmthresholds.sts1.nearend.1day.PJCS-PDET	9600 (seconds)	0 - 86400
OC3.pmthresholds.sts1.nearend.1day.PJCS-PGEN	9600 (seconds)	0 - 86400
OC3.pmthresholds.sts1.nearend.1day.PPJC-PDET	5760 (count)	0 - 691200000
OC3.pmthresholds.sts1.nearend.1day.PPJC-PGEN	5760 (count)	0 - 691200000
OC3.pmthresholds.sts1.nearend.1day.SES	7 (seconds)	0 - 86400
OC3.pmthresholds.sts1.nearend.1day.UAS	10 (seconds)	0 - 86400
OC3.pmthresholds.sts3c.nearend.15min.CV	25 (B3 count)	0 - 2160000
OC3.pmthresholds.sts3c.nearend.15min.ES	20 (seconds)	0 - 900
OC3.pmthresholds.sts3c.nearend.15min.FC	10 (count)	0 - 72
OC3.pmthresholds.sts3c.nearend.15min.NPJC-PDET	60 (count)	0 - 7200000

Table C-12 OC-3 Card Default Settings (continued)

Default Name	Default Value	Default Domain
OC3.pmthresholds.sts3c.nearend.15min.NPJC-PGEN	60 (count)	0 - 7200000
OC3.pmthresholds.sts3c.nearend.15min.PJCDIFF	60 (count)	0 - 14400000
OC3.pmthresholds.sts3c.nearend.15min.PJCS-PDET	100 (seconds)	0 - 900
OC3.pmthresholds.sts3c.nearend.15min.PJCS-PGEN	100 (seconds)	0 - 900
OC3.pmthresholds.sts3c.nearend.15min.PPJC-PDET	60 (count)	0 - 7200000
OC3.pmthresholds.sts3c.nearend.15min.PPJC-PGEN	60 (count)	0 - 7200000
OC3.pmthresholds.sts3c.nearend.15min.SES	3 (seconds)	0 - 900
OC3.pmthresholds.sts3c.nearend.15min.UAS	10 (seconds)	0 - 900
OC3.pmthresholds.sts3c.nearend.1day.CV	250 (B3 count)	0 - 207360000
OC3.pmthresholds.sts3c.nearend.1day.ES	200 (seconds)	0 - 86400
OC3.pmthresholds.sts3c.nearend.1day.FC	40 (count)	0 - 6912
OC3.pmthresholds.sts3c.nearend.1day.NPJC-PDET	5760 (count)	0 - 691200000
OC3.pmthresholds.sts3c.nearend.1day.NPJC-PGEN	5760 (count)	0 - 691200000
OC3.pmthresholds.sts3c.nearend.1day.PJCDIFF	5760 (count)	0 - 1382400000
OC3.pmthresholds.sts3c.nearend.1day.PJCS-PDET	9600 (seconds)	0 - 86400
OC3.pmthresholds.sts3c.nearend.1day.PJCS-PGEN	9600 (seconds)	0 - 86400
OC3.pmthresholds.sts3c.nearend.1day.PPJC-PDET	5760 (count)	0 - 691200000
OC3.pmthresholds.sts3c.nearend.1day.PPJC-PGEN	5760 (count)	0 - 691200000
OC3.pmthresholds.sts3c.nearend.1day.SES	7 (seconds)	0 - 86400
OC3.pmthresholds.sts3c.nearend.1day.UAS	10 (seconds)	0 - 86400

C.2.3.13 OC3-8 Card Default Settings

Table C-13 lists the eight-port OC3-8 (OC3 IR/STM1 SH 1310-8) card default settings.

Table C-13 OC3-8 Card Default Settings

Default Name	Default Value	Default Domain
OC3-8.config.line.AdminSSMIn	STU	PRS, STU, ST2, TNC, ST3E, ST3, SMC, ST4, DUS, RES
OC3-8.config.line.AINSSoakTime	08:00 (hours:mins)	00:00, 00:15, 00:30 .. 48:00
OC3-8.config.line.AlsMode	Disabled	Disabled, Auto Restart, Manual Restart, Manual Restart for Test
OC3-8.config.line.AlsRecoveryPulseDuration	2.0 (seconds)	2.0, 2.1, 2.2 .. 100.0 when AlsMode Disabled, Auto Restart, Manual Restart; 80.0, 80.1, 80.2 .. 100.0 when AlsMode Manual Restart for Test
OC3-8.config.line.AlsRecoveryPulseInterval	100 (seconds)	60 - 300
OC3-8.config.line.PJStsMon#	0 (STS #)	0 - 3

Table C-13 OC3-8 Card Default Settings (continued)

Default Name	Default Value	Default Domain
OC3-8.config.line.SDBER	1E-7	1E-5, 1E-6, 1E-7, 1E-8, 1E-9
OC3-8.config.line.Send<FF>DoNotUse	FALSE	FALSE when SendDoNotUse TRUE; FALSE, TRUE when SendDoNotUse FALSE
OC3-8.config.line.SendDoNotUse	FALSE	FALSE, TRUE
OC3-8.config.line.SFBER	1E-4	1E-3, 1E-4, 1E-5
OC3-8.config.line.State	IS,AINS	IS, OOS,DSBLD, OOS,MT, IS,AINS
OC3-8.config.line.SyncMsgIn	TRUE	FALSE, TRUE
OC3-8.config.sts.IPPMEnabled	FALSE	TRUE, FALSE
OC3-8.physicalthresholds.alarm.LBC-HIGH	200 (%)	LBC-LOW, LBC-LOW + 1.0, LBC-LOW + 2.0 .. 255.0
OC3-8.physicalthresholds.alarm.LBC-LOW	20 (%)	0.0, 1.0, 2.0 .. LBC-HIGH
OC3-8.physicalthresholds.alarm.OPR-HIGH	200 (%)	OPR-LOW, OPR-LOW + 1.0, OPR-LOW + 2.0 .. 255.0
OC3-8.physicalthresholds.alarm.OPR-LOW	50 (%)	0.0, 1.0, 2.0 .. OPR-HIGH
OC3-8.physicalthresholds.alarm.OPT-HIGH	120 (%)	OPT-LOW, OPT-LOW + 1.0, OPT-LOW + 2.0 .. 255.0
OC3-8.physicalthresholds.alarm.OPT-LOW	80 (%)	0.0, 1.0, 2.0 .. OPT-HIGH
OC3-8.physicalthresholds.warning.15min.LBC-HIGH	200 (%)	LBC-LOW, LBC-LOW + 1.0, LBC-LOW + 2.0 .. 255.0
OC3-8.physicalthresholds.warning.15min.LBC-LOW	20 (%)	0.0, 1.0, 2.0 .. LBC-HIGH
OC3-8.physicalthresholds.warning.15min.OPR-HIGH	200 (%)	OPR-LOW, OPR-LOW + 1.0, OPR-LOW + 2.0 .. 255.0
OC3-8.physicalthresholds.warning.15min.OPR-LOW	50 (%)	0.0, 1.0, 2.0 .. OPR-HIGH
OC3-8.physicalthresholds.warning.15min.OPT-HIGH	120 (%)	OPT-LOW, OPT-LOW + 1.0, OPT-LOW + 2.0 .. 255.0
OC3-8.physicalthresholds.warning.15min.OPT-LOW	80 (%)	0.0, 1.0, 2.0 .. OPT-HIGH
OC3-8.physicalthresholds.warning.1day.LBC-HIGH	200 (%)	LBC-LOW, LBC-LOW + 1.0, LBC-LOW + 2.0 .. 255.0
OC3-8.physicalthresholds.warning.1day.LBC-LOW	20 (%)	0.0, 1.0, 2.0 .. LBC-HIGH
OC3-8.physicalthresholds.warning.1day.OPR-HIGH	200 (%)	OPR-LOW, OPR-LOW + 1.0, OPR-LOW + 2.0 .. 255.0
OC3-8.physicalthresholds.warning.1day.OPR-LOW	50 (%)	0.0, 1.0, 2.0 .. OPR-HIGH
OC3-8.physicalthresholds.warning.1day.OPT-HIGH	120 (%)	OPT-LOW, OPT-LOW + 1.0, OPT-LOW + 2.0 .. 255.0
OC3-8.physicalthresholds.warning.1day.OPT-LOW	80 (%)	0.0, 1.0, 2.0 .. OPT-HIGH
OC3-8.pmthresholds.line.farend.15min.CV	1312 (B2 count)	0 - 137700
OC3-8.pmthresholds.line.farend.15min.ES	87 (seconds)	0 - 900
OC3-8.pmthresholds.line.farend.15min.FC	10 (count)	0 - 72

Table C-13 OC3-8 Card Default Settings (continued)

Default Name	Default Value	Default Domain
OC3-8.pmthresholds.line.farend.15min.SES	1 (seconds)	0 - 900
OC3-8.pmthresholds.line.farend.15min.UAS	3 (seconds)	0 - 900
OC3-8.pmthresholds.line.farend.1day.CV	13120 (B2 count)	0 - 13219200
OC3-8.pmthresholds.line.farend.1day.ES	864 (seconds)	0 - 86400
OC3-8.pmthresholds.line.farend.1day.FC	40 (count)	0 - 6912
OC3-8.pmthresholds.line.farend.1day.SES	4 (seconds)	0 - 86400
OC3-8.pmthresholds.line.farend.1day.UAS	10 (seconds)	0 - 86400
OC3-8.pmthresholds.line.nearend.15min.CV	1312 (B2 count)	0 - 137700
OC3-8.pmthresholds.line.nearend.15min.ES	87 (seconds)	0 - 900
OC3-8.pmthresholds.line.nearend.15min.FC	10 (count)	0 - 72
OC3-8.pmthresholds.line.nearend.15min.PSC	1 (count)	0 - 600
OC3-8.pmthresholds.line.nearend.15min.PSD	300 (seconds)	0 - 900
OC3-8.pmthresholds.line.nearend.15min.SES	1 (seconds)	0 - 900
OC3-8.pmthresholds.line.nearend.15min.UAS	3 (seconds)	0 - 900
OC3-8.pmthresholds.line.nearend.1day.CV	13120 (B2 count)	0 - 13219200
OC3-8.pmthresholds.line.nearend.1day.ES	864 (seconds)	0 - 86400
OC3-8.pmthresholds.line.nearend.1day.FC	40 (count)	0 - 6912
OC3-8.pmthresholds.line.nearend.1day.PSC	5 (count)	0 - 57600
OC3-8.pmthresholds.line.nearend.1day.PSD	600 (seconds)	0 - 86400
OC3-8.pmthresholds.line.nearend.1day.SES	4 (seconds)	0 - 86400
OC3-8.pmthresholds.line.nearend.1day.UAS	10 (seconds)	0 - 86400
OC3-8.pmthresholds.section.nearend.15min.CV	10000 (B1 count)	0 - 138600
OC3-8.pmthresholds.section.nearend.15min.ES	500 (seconds)	0 - 900
OC3-8.pmthresholds.section.nearend.15min.SEFS	500 (seconds)	0 - 900
OC3-8.pmthresholds.section.nearend.15min.SES	500 (seconds)	0 - 900
OC3-8.pmthresholds.section.nearend.1day.CV	100000 (B1 count)	0 - 13305600
OC3-8.pmthresholds.section.nearend.1day.ES	5000 (seconds)	0 - 86400
OC3-8.pmthresholds.section.nearend.1day.SEFS	5000 (seconds)	0 - 86400
OC3-8.pmthresholds.section.nearend.1day.SES	5000 (seconds)	0 - 86400
OC3-8.pmthresholds.sts1.nearend.15min.CV	15 (B3 count)	0 - 2160000
OC3-8.pmthresholds.sts1.nearend.15min.ES	12 (seconds)	0 - 900
OC3-8.pmthresholds.sts1.nearend.15min.FC	10 (count)	0 - 72
OC3-8.pmthresholds.sts1.nearend.15min.NPJC-PDET	60 (count)	0 - 7200000
OC3-8.pmthresholds.sts1.nearend.15min.NPJC-PGEN	60 (count)	0 - 7200000
OC3-8.pmthresholds.sts1.nearend.15min.PJCDIFF	60 (count)	0 - 14400000
OC3-8.pmthresholds.sts1.nearend.15min.PJCS-PDET	100 (seconds)	0 - 900

Table C-13 OC3-8 Card Default Settings (continued)

Default Name	Default Value	Default Domain
OC3-8.pmthresholds.sts1.nearend.15min.PJCS-PGEN	100 (seconds)	0 - 900
OC3-8.pmthresholds.sts1.nearend.15min.PPJC-PDET	60 (count)	0 - 7200000
OC3-8.pmthresholds.sts1.nearend.15min.PPJC-PGEN	60 (count)	0 - 7200000
OC3-8.pmthresholds.sts1.nearend.15min.SES	3 (seconds)	0 - 900
OC3-8.pmthresholds.sts1.nearend.15min.UAS	10 (seconds)	0 - 900
OC3-8.pmthresholds.sts1.nearend.1day.CV	125 (B3 count)	0 - 207360000
OC3-8.pmthresholds.sts1.nearend.1day.ES	100 (seconds)	0 - 86400
OC3-8.pmthresholds.sts1.nearend.1day.FC	40 (count)	0 - 6912
OC3-8.pmthresholds.sts1.nearend.1day.NPJC-PDET	5760 (count)	0 - 691200000
OC3-8.pmthresholds.sts1.nearend.1day.NPJC-PGEN	5760 (count)	0 - 691200000
OC3-8.pmthresholds.sts1.nearend.1day.PJCDIFF	5760 (count)	0 - 1382400000
OC3-8.pmthresholds.sts1.nearend.1day.PJCS-PDET	9600 (seconds)	0 - 86400
OC3-8.pmthresholds.sts1.nearend.1day.PJCS-PGEN	9600 (seconds)	0 - 86400
OC3-8.pmthresholds.sts1.nearend.1day.PPJC-PDET	5760 (count)	0 - 691200000
OC3-8.pmthresholds.sts1.nearend.1day.PPJC-PGEN	5760 (count)	0 - 691200000
OC3-8.pmthresholds.sts1.nearend.1day.SES	7 (seconds)	0 - 86400
OC3-8.pmthresholds.sts1.nearend.1day.UAS	10 (seconds)	0 - 86400
OC3-8.pmthresholds.sts3c.nearend.15min.CV	25 (B3 count)	0 - 2160000
OC3-8.pmthresholds.sts3c.nearend.15min.ES	20 (seconds)	0 - 900
OC3-8.pmthresholds.sts3c.nearend.15min.FC	10 (count)	0 - 72
OC3-8.pmthresholds.sts3c.nearend.15min.NPJC-PDET	60 (count)	0 - 7200000
OC3-8.pmthresholds.sts3c.nearend.15min.NPJC-PGEN	60 (count)	0 - 7200000
OC3-8.pmthresholds.sts3c.nearend.15min.PJCDIFF	60 (count)	0 - 14400000
OC3-8.pmthresholds.sts3c.nearend.15min.PJCS-PDET	100 (seconds)	0 - 900
OC3-8.pmthresholds.sts3c.nearend.15min.PJCS-PGEN	100 (seconds)	0 - 900
OC3-8.pmthresholds.sts3c.nearend.15min.PPJC-PDET	60 (count)	0 - 7200000
OC3-8.pmthresholds.sts3c.nearend.15min.PPJC-PGEN	60 (count)	0 - 7200000
OC3-8.pmthresholds.sts3c.nearend.15min.SES	3 (seconds)	0 - 900
OC3-8.pmthresholds.sts3c.nearend.15min.UAS	10 (seconds)	0 - 900
OC3-8.pmthresholds.sts3c.nearend.1day.CV	250 (B3 count)	0 - 207360000
OC3-8.pmthresholds.sts3c.nearend.1day.ES	200 (seconds)	0 - 86400
OC3-8.pmthresholds.sts3c.nearend.1day.FC	40 (count)	0 - 6912
OC3-8.pmthresholds.sts3c.nearend.1day.NPJC-PDET	5760 (count)	0 - 691200000
OC3-8.pmthresholds.sts3c.nearend.1day.NPJC-PGEN	5760 (count)	0 - 691200000
OC3-8.pmthresholds.sts3c.nearend.1day.PJCDIFF	5760 (count)	0 - 1382400000
OC3-8.pmthresholds.sts3c.nearend.1day.PJCS-PDET	9600 (seconds)	0 - 691200000

Table C-13 OC3-8 Card Default Settings (continued)

Default Name	Default Value	Default Domain
OC3-8.pmthresholds.sts3c.nearend.1day.PJCS-PGEN	9600 (seconds)	0 - 86400
OC3-8.pmthresholds.sts3c.nearend.1day.PPJC-PDET	5760 (count)	0 - 691200000
OC3-8.pmthresholds.sts3c.nearend.1day.PPJC-PGEN	5760 (count)	0 - 691200000
OC3-8.pmthresholds.sts3c.nearend.1day.SES	7 (seconds)	0 - 86400
OC3-8.pmthresholds.sts3c.nearend.1day.UAS	10 (seconds)	0 - 86400

C.2.3.14 OC-12 Card Default Settings

Table C-14 lists the OC-12 (OC12 IR/STM4 SH 1310, OC12 LR/STM4 LH 1310, and OC12 LR/STM4 LH 1550) card default settings.

Table C-14 OC-12 Card Default Settings

Default Name	Default Value	Default Domain
OC12.config.line.AdminSSMIn	STU	PRS, STU, ST2, TNC, ST3E, ST3, SMC, ST4, DUS, RES
OC12.config.line.AINSSoakTime	08:00 (hours:mins)	00:00, 00:15, 00:30 .. 48:00
OC12.config.line.PJStsMon#	0 (STS #)	0 - 12
OC12.config.line.SDBER	1E-7	1E-5, 1E-6, 1E-7, 1E-8, 1E-9
OC12.config.line.Send<FF>DoNotUse	FALSE	FALSE when SendDoNotUse TRUE; FALSE, TRUE when SendDoNotUse FALSE
OC12.config.line.SendDoNotUse	FALSE	FALSE, TRUE
OC12.config.line.SFBER	1E-4	1E-3, 1E-4, 1E-5
OC12.config.line.State	IS,AINS	IS, OOS,DSBLD, OOS,MT, IS,AINS
OC12.config.line.SyncMsgIn	TRUE	FALSE, TRUE
OC12.config.sts.IPPMEnabled	FALSE	TRUE, FALSE
OC12.pmthresholds.line.farend.15min.CV	5315 (B2 count)	0 - 552600
OC12.pmthresholds.line.farend.15min.ES	87 (seconds)	0 - 900
OC12.pmthresholds.line.farend.15min.FC	10 (count)	0 - 72
OC12.pmthresholds.line.farend.15min.SES	1 (seconds)	0 - 900
OC12.pmthresholds.line.farend.15min.UAS	3 (seconds)	0 - 900
OC12.pmthresholds.line.farend.1day.CV	53150 (B2 count)	0 - 53049600
OC12.pmthresholds.line.farend.1day.ES	864 (seconds)	0 - 86400
OC12.pmthresholds.line.farend.1day.FC	40 (count)	0 - 6912
OC12.pmthresholds.line.farend.1day.SES	4 (seconds)	0 - 86400
OC12.pmthresholds.line.farend.1day.UAS	10 (seconds)	0 - 86400
OC12.pmthresholds.line.nearend.15min.CV	5315 (B2 count)	0 - 552600
OC12.pmthresholds.line.nearend.15min.ES	87 (seconds)	0 - 900

Table C-14 OC-12 Card Default Settings (continued)

Default Name	Default Value	Default Domain
OC12.pmthresholds.line.nearend.15min.FC	10 (count)	0 - 72
OC12.pmthresholds.line.nearend.15min.PSC	1 (count)	0 - 600
OC12.pmthresholds.line.nearend.15min.PSC-W	1 (count)	0 - 600
OC12.pmthresholds.line.nearend.15min.PSD	300 (seconds)	0 - 900
OC12.pmthresholds.line.nearend.15min.PSD-W	300 (seconds)	0 - 900
OC12.pmthresholds.line.nearend.15min.SES	1 (seconds)	0 - 900
OC12.pmthresholds.line.nearend.15min.UAS	3 (seconds)	0 - 900
OC12.pmthresholds.line.nearend.1day.CV	53150 (B2 count)	0 - 53049600
OC12.pmthresholds.line.nearend.1day.ES	864 (seconds)	0 - 86400
OC12.pmthresholds.line.nearend.1day.FC	40 (count)	0 - 6912
OC12.pmthresholds.line.nearend.1day.PSC	5 (count)	0 - 57600
OC12.pmthresholds.line.nearend.1day.PSC-W	5 (count)	0 - 57600
OC12.pmthresholds.line.nearend.1day.PSD	600 (seconds)	0 - 86400
OC12.pmthresholds.line.nearend.1day.PSD-W	600 (seconds)	0 - 86400
OC12.pmthresholds.line.nearend.1day.SES	4 (seconds)	0 - 86400
OC12.pmthresholds.line.nearend.1day.UAS	10 (seconds)	0 - 86400
OC12.pmthresholds.section.nearend.15min.CV	10000 (B1 count)	0 - 553500
OC12.pmthresholds.section.nearend.15min.ES	500 (seconds)	0 - 900
OC12.pmthresholds.section.nearend.15min.SEFS	500 (seconds)	0 - 900
OC12.pmthresholds.section.nearend.15min.SES	500 (seconds)	0 - 900
OC12.pmthresholds.section.nearend.1day.CV	100000 (B1 count)	0 - 53136000
OC12.pmthresholds.section.nearend.1day.ES	5000 (seconds)	0 - 86400
OC12.pmthresholds.section.nearend.1day.SEFS	5000 (seconds)	0 - 86400
OC12.pmthresholds.section.nearend.1day.SES	5000 (seconds)	0 - 86400
OC12.pmthresholds.sts1.nearend.15min.CV	15 (B3 count)	0 - 2160000
OC12.pmthresholds.sts1.nearend.15min.ES	12 (seconds)	0 - 900
OC12.pmthresholds.sts1.nearend.15min.FC	10 (count)	0 - 72
OC12.pmthresholds.sts1.nearend.15min.NPJC-PDET	60 (count)	0 - 7200000
OC12.pmthresholds.sts1.nearend.15min.NPJC-PGEN	60 (count)	0 - 7200000
OC12.pmthresholds.sts1.nearend.15min.PJCDIFF	60 (count)	0 - 14400000
OC12.pmthresholds.sts1.nearend.15min.PJCS-PDET	100 (seconds)	0 - 900
OC12.pmthresholds.sts1.nearend.15min.PJCS-PGEN	100 (seconds)	0 - 900
OC12.pmthresholds.sts1.nearend.15min.PPJC-PDET	60 (count)	0 - 7200000
OC12.pmthresholds.sts1.nearend.15min.PPJC-PGEN	60 (count)	0 - 7200000
OC12.pmthresholds.sts1.nearend.15min.SES	3 (seconds)	0 - 900
OC12.pmthresholds.sts1.nearend.15min.UAS	10 (seconds)	0 - 900

Table C-14 OC-12 Card Default Settings (continued)

Default Name	Default Value	Default Domain
OC12.pmthresholds.sts1.nearend.1day.CV	125 (B3 count)	0 - 207360000
OC12.pmthresholds.sts1.nearend.1day.ES	100 (seconds)	0 - 86400
OC12.pmthresholds.sts1.nearend.1day.FC	40 (count)	0 - 6912
OC12.pmthresholds.sts1.nearend.1day.NPJC-PDET	5760 (count)	0 - 691200000
OC12.pmthresholds.sts1.nearend.1day.NPJC-PGEN	5760 (count)	0 - 691200000
OC12.pmthresholds.sts1.nearend.1day.PJCDIFF	5760 (count)	0 - 1382400000
OC12.pmthresholds.sts1.nearend.1day.PJCS-PDET	9600 (seconds)	0 - 86400
OC12.pmthresholds.sts1.nearend.1day.PJCS-PGEN	9600 (seconds)	0 - 86400
OC12.pmthresholds.sts1.nearend.1day.PPJC-PDET	5760 (count)	0 - 691200000
OC12.pmthresholds.sts1.nearend.1day.PPJC-PGEN	5760 (count)	0 - 691200000
OC12.pmthresholds.sts1.nearend.1day.SES	7 (seconds)	0 - 86400
OC12.pmthresholds.sts1.nearend.1day.UAS	10 (seconds)	0 - 86400
OC12.pmthresholds.sts12c.nearend.15min.CV	75 (B3 count)	0 - 2160000
OC12.pmthresholds.sts12c.nearend.15min.ES	60 (seconds)	0 - 900
OC12.pmthresholds.sts12c.nearend.15min.FC	10 (count)	0 - 72
OC12.pmthresholds.sts12c.nearend.15min.NPJC-PDET	60 (count)	0 - 7200000
OC12.pmthresholds.sts12c.nearend.15min.NPJC-PGEN	60 (count)	0 - 7200000
OC12.pmthresholds.sts12c.nearend.15min.PJCDIFF	60 (count)	0 - 14400000
OC12.pmthresholds.sts12c.nearend.15min.PJCS-PDET	100 (seconds)	0 - 900
OC12.pmthresholds.sts12c.nearend.15min.PJCS-PGEN	100 (seconds)	0 - 900
OC12.pmthresholds.sts12c.nearend.15min.PPJC-PDET	60 (count)	0 - 7200000
OC12.pmthresholds.sts12c.nearend.15min.PPJC-PGEN	60 (count)	0 - 7200000
OC12.pmthresholds.sts12c.nearend.15min.SES	3 (seconds)	0 - 900
OC12.pmthresholds.sts12c.nearend.15min.UAS	10 (seconds)	0 - 900
OC12.pmthresholds.sts12c.nearend.1day.CV	750 (B3 count)	0 - 207360000
OC12.pmthresholds.sts12c.nearend.1day.ES	600 (seconds)	0 - 86400
OC12.pmthresholds.sts12c.nearend.1day.FC	40 (count)	0 - 6912
OC12.pmthresholds.sts12c.nearend.1day.NPJC-PDET	5760 (count)	0 - 691200000
OC12.pmthresholds.sts12c.nearend.1day.NPJC-PGEN	5760 (count)	0 - 691200000
OC12.pmthresholds.sts12c.nearend.1day.PJCDIFF	5760 (count)	0 - 1382400000
OC12.pmthresholds.sts12c.nearend.1day.PJCS-PDET	9600 (seconds)	0 - 86400
OC12.pmthresholds.sts12c.nearend.1day.PJCS-PGEN	9600 (seconds)	0 - 86400
OC12.pmthresholds.sts12c.nearend.1day.PPJC-PDET	5760 (count)	0 - 691200000
OC12.pmthresholds.sts12c.nearend.1day.PPJC-PGEN	5760 (count)	0 - 691200000
OC12.pmthresholds.sts12c.nearend.1day.SES	7 (seconds)	0 - 86400
OC12.pmthresholds.sts12c.nearend.1day.UAS	10 (seconds)	0 - 86400

Table C-14 OC-12 Card Default Settings (continued)

Default Name	Default Value	Default Domain
OC12.pmthresholds.sts3c-9c.nearend.15min.CV	25 (B3 count)	0 - 2160000
OC12.pmthresholds.sts3c-9c.nearend.15min.ES	20 (seconds)	0 - 900
OC12.pmthresholds.sts3c-9c.nearend.15min.FC	10 (count)	0 - 72
OC12.pmthresholds.sts3c-9c.nearend.15min.NPJC-PDET	60 (count)	0 - 7200000
OC12.pmthresholds.sts3c-9c.nearend.15min.NPJC-PGEN	60 (count)	0 - 7200000
OC12.pmthresholds.sts3c-9c.nearend.15min.PJCDIFF	60 (count)	0 - 14400000
OC12.pmthresholds.sts3c-9c.nearend.15min.PJCS-PDET	100 (seconds)	0 - 900
OC12.pmthresholds.sts3c-9c.nearend.15min.PJCS-PGEN	100 (seconds)	0 - 900
OC12.pmthresholds.sts3c-9c.nearend.15min.PPJC-PDET	60 (count)	0 - 7200000
OC12.pmthresholds.sts3c-9c.nearend.15min.PPJC-PGEN	60 (count)	0 - 7200000
OC12.pmthresholds.sts3c-9c.nearend.15min.SES	3 (seconds)	0 - 900
OC12.pmthresholds.sts3c-9c.nearend.15min.UAS	10 (seconds)	0 - 900
OC12.pmthresholds.sts3c-9c.nearend.1day.CV	250 (B3 count)	0 - 207360000
OC12.pmthresholds.sts3c-9c.nearend.1day.ES	200 (seconds)	0 - 86400
OC12.pmthresholds.sts3c-9c.nearend.1day.FC	40 (count)	0 - 6912
OC12.pmthresholds.sts3c-9c.nearend.1day.NPJC-PDET	5760 (count)	0 - 691200000
OC12.pmthresholds.sts3c-9c.nearend.1day.NPJC-PGEN	5760 (count)	0 - 691200000
OC12.pmthresholds.sts3c-9c.nearend.1day.PJCDIFF	5760 (count)	0 - 1382400000
OC12.pmthresholds.sts3c-9c.nearend.1day.PJCS-PDET	9600 (seconds)	0 - 86400
OC12.pmthresholds.sts3c-9c.nearend.1day.PJCS-PGEN	9600 (seconds)	0 - 86400
OC12.pmthresholds.sts3c-9c.nearend.1day.PPJC-PDET	5760 (count)	0 - 691200000
OC12.pmthresholds.sts3c-9c.nearend.1day.PPJC-PGEN	5760 (count)	0 - 691200000
OC12.pmthresholds.sts3c-9c.nearend.1day.SES	7 (seconds)	0 - 86400
OC12.pmthresholds.sts3c-9c.nearend.1day.UAS	10 (seconds)	0 - 86400

C.2.3.15 OC12-4 Card Default Settings

Table C-15 lists the four-port OC12-4 (OC12 IR/STM4 SH 1310-4) card default settings.

Table C-15 OC12-4 Card Default Settings

Default Name	Default Value	Default Domain
OC12-4.config.line.AdminSSMIn	STU	PRS, STU, ST2, TNC, ST3E, ST3, SMC, ST4, DUS, RES
OC12-4.config.line.AINSSoakTime	08:00 (hours:mins)	00:00, 00:15, 00:30 .. 48:00
OC12-4.config.line.PJStsMon#	0 (STS #)	0 - 12
OC12-4.config.line.SDBER	1E-7	1E-5, 1E-6, 1E-7, 1E-8, 1E-9

Table C-15 OC12-4 Card Default Settings (continued)

Default Name	Default Value	Default Domain
OC12-4.config.line.Send<FF>DoNotUse	FALSE	FALSE when SendDoNotUse TRUE; FALSE, TRUE when SendDoNotUse FALSE
OC12-4.config.line.SendDoNotUse	FALSE	FALSE, TRUE
OC12-4.config.line.SFBER	1E-4	1E-3, 1E-4, 1E-5
OC12-4.config.line.State	IS,AINS	IS, OOS,DSBLD, OOS,MT, IS,AINS
OC12-4.config.line.SyncMsgIn	TRUE	FALSE, TRUE
OC12-4.config.sts.IPPMEnabled	FALSE	TRUE, FALSE
OC12-4.pmthresholds.line.farend.15min.CV	5315 (B2 count)	0 - 552600
OC12-4.pmthresholds.line.farend.15min.ES	87 (seconds)	0 - 900
OC12-4.pmthresholds.line.farend.15min.FC	10 (count)	0 - 72
OC12-4.pmthresholds.line.farend.15min.SES	1 (seconds)	0 - 900
OC12-4.pmthresholds.line.farend.15min.UAS	3 (seconds)	0 - 900
OC12-4.pmthresholds.line.farend.1day.CV	53150 (B2 count)	0 - 53049600
OC12-4.pmthresholds.line.farend.1day.ES	864 (seconds)	0 - 86400
OC12-4.pmthresholds.line.farend.1day.FC	40 (count)	0 - 6912
OC12-4.pmthresholds.line.farend.1day.SES	4 (seconds)	0 - 86400
OC12-4.pmthresholds.line.farend.1day.UAS	10 (seconds)	0 - 86400
OC12-4.pmthresholds.line.nearend.15min.CV	5315 (B2 count)	0 - 552600
OC12-4.pmthresholds.line.nearend.15min.ES	87 (seconds)	0 - 900
OC12-4.pmthresholds.line.nearend.15min.FC	10 (count)	0 - 72
OC12-4.pmthresholds.line.nearend.15min.PSC	1 (count)	0 - 600
OC12-4.pmthresholds.line.nearend.15min.PSC-W	1 (count)	0 - 600
OC12-4.pmthresholds.line.nearend.15min.PSD	300 (seconds)	0 - 900
OC12-4.pmthresholds.line.nearend.15min.PSD-W	300 (seconds)	0 - 900
OC12-4.pmthresholds.line.nearend.15min.SES	1 (seconds)	0 - 900
OC12-4.pmthresholds.line.nearend.15min.UAS	3 (seconds)	0 - 900
OC12-4.pmthresholds.line.nearend.1day.CV	53150 (B2 count)	0 - 53049600
OC12-4.pmthresholds.line.nearend.1day.ES	864 (seconds)	0 - 86400
OC12-4.pmthresholds.line.nearend.1day.FC	40 (count)	0 - 6912
OC12-4.pmthresholds.line.nearend.1day.PSC	5 (count)	0 - 57600
OC12-4.pmthresholds.line.nearend.1day.PSC-W	5 (count)	0 - 57600
OC12-4.pmthresholds.line.nearend.1day.PSD	600 (seconds)	0 - 86400
OC12-4.pmthresholds.line.nearend.1day.PSD-W	600 (seconds)	0 - 86400
OC12-4.pmthresholds.line.nearend.1day.SES	4 (seconds)	0 - 86400
OC12-4.pmthresholds.line.nearend.1day.UAS	10 (seconds)	0 - 86400
OC12-4.pmthresholds.section.nearend.15min.CV	10000 (B1 count)	0 - 553500

Table C-15 OC12-4 Card Default Settings (continued)

Default Name	Default Value	Default Domain
OC12-4.pmthresholds.section.nearend.15min.ES	500 (seconds)	0 - 900
OC12-4.pmthresholds.section.nearend.15min.SEFS	500 (seconds)	0 - 900
OC12-4.pmthresholds.section.nearend.15min.SES	500 (seconds)	0 - 900
OC12-4.pmthresholds.section.nearend.1day.CV	100000 (B1 count)	0 - 53136000
OC12-4.pmthresholds.section.nearend.1day.ES	5000 (seconds)	0 - 86400
OC12-4.pmthresholds.section.nearend.1day.SEFS	5000 (seconds)	0 - 86400
OC12-4.pmthresholds.section.nearend.1day.SES	5000 (seconds)	0 - 86400
OC12-4.pmthresholds.sts1.nearend.15min.CV	15 (B3 count)	0 - 2160000
OC12-4.pmthresholds.sts1.nearend.15min.ES	12 (seconds)	0 - 900
OC12-4.pmthresholds.sts1.nearend.15min.FC	10 (count)	0 - 72
OC12-4.pmthresholds.sts1.nearend.15min.NPJC-PDET	60 (count)	0 - 7200000
OC12-4.pmthresholds.sts1.nearend.15min.NPJC-PGEN	60 (count)	0 - 7200000
OC12-4.pmthresholds.sts1.nearend.15min.PJCDIFF	60 (count)	0 - 14400000
OC12-4.pmthresholds.sts1.nearend.15min.PJCS-PDET	100 (seconds)	0 - 900
OC12-4.pmthresholds.sts1.nearend.15min.PJCS-PGEN	100 (seconds)	0 - 900
OC12-4.pmthresholds.sts1.nearend.15min.PPJC-PDET	60 (count)	0 - 7200000
OC12-4.pmthresholds.sts1.nearend.15min.PPJC-PGEN	60 (count)	0 - 7200000
OC12-4.pmthresholds.sts1.nearend.15min.SES	3 (seconds)	0 - 900
OC12-4.pmthresholds.sts1.nearend.15min.UAS	10 (seconds)	0 - 900
OC12-4.pmthresholds.sts1.nearend.1day.CV	125 (B3 count)	0 - 207360000
OC12-4.pmthresholds.sts1.nearend.1day.ES	100 (seconds)	0 - 86400
OC12-4.pmthresholds.sts1.nearend.1day.FC	40 (count)	0 - 6912
OC12-4.pmthresholds.sts1.nearend.1day.NPJC-PDET	5760 (count)	0 - 691200000
OC12-4.pmthresholds.sts1.nearend.1day.NPJC-PGEN	5760 (count)	0 - 691200000
OC12-4.pmthresholds.sts1.nearend.1day.PJCDIFF	5760 (count)	0 - 1382400000
OC12-4.pmthresholds.sts1.nearend.1day.PJCS-PDET	9600 (seconds)	0 - 86400
OC12-4.pmthresholds.sts1.nearend.1day.PJCS-PGEN	9600 (seconds)	0 - 86400
OC12-4.pmthresholds.sts1.nearend.1day.PPJC-PDET	5760 (count)	0 - 691200000
OC12-4.pmthresholds.sts1.nearend.1day.PPJC-PGEN	5760 (count)	0 - 691200000
OC12-4.pmthresholds.sts1.nearend.1day.SES	7 (seconds)	0 - 86400
OC12-4.pmthresholds.sts1.nearend.1day.UAS	10 (seconds)	0 - 86400
OC12-4.pmthresholds.sts12c.nearend.15min.CV	75 (B3 count)	0 - 2160000
OC12-4.pmthresholds.sts12c.nearend.15min.ES	60 (seconds)	0 - 900
OC12-4.pmthresholds.sts12c.nearend.15min.FC	10 (count)	0 - 72
OC12-4.pmthresholds.sts12c.nearend.15min.NPJC-PDET	60 (count)	0 - 7200000
OC12-4.pmthresholds.sts12c.nearend.15min.NPJC-PGEN	60 (count)	0 - 7200000

Table C-15 OC12-4 Card Default Settings (continued)

Default Name	Default Value	Default Domain
OC12-4.pmthresholds.sts12c.nearend.15min.PJCDIFF	60 (count)	0 - 14400000
OC12-4.pmthresholds.sts12c.nearend.15min.PJCS-PDET	100 (seconds)	0 - 900
OC12-4.pmthresholds.sts12c.nearend.15min.PJCS-PGEN	100 (seconds)	0 - 900
OC12-4.pmthresholds.sts12c.nearend.15min.PPJC-PDET	60 (count)	0 - 7200000
OC12-4.pmthresholds.sts12c.nearend.15min.PPJC-PGEN	60 (count)	0 - 7200000
OC12-4.pmthresholds.sts12c.nearend.15min.SES	3 (seconds)	0 - 900
OC12-4.pmthresholds.sts12c.nearend.15min.UAS	10 (seconds)	0 - 900
OC12-4.pmthresholds.sts12c.nearend.1day.CV	750 (B3 count)	0 - 207360000
OC12-4.pmthresholds.sts12c.nearend.1day.ES	600 (seconds)	0 - 86400
OC12-4.pmthresholds.sts12c.nearend.1day.FC	40 (count)	0 - 6912
OC12-4.pmthresholds.sts12c.nearend.1day.NPJC-PDET	5760 (count)	0 - 691200000
OC12-4.pmthresholds.sts12c.nearend.1day.NPJC-PGEN	5760 (count)	0 - 691200000
OC12-4.pmthresholds.sts12c.nearend.1day.PJCDIFF	5760 (count)	0 - 1382400000
OC12-4.pmthresholds.sts12c.nearend.1day.PJCS-PDET	9600 (seconds)	0 - 86400
OC12-4.pmthresholds.sts12c.nearend.1day.PJCS-PGEN	9600 (seconds)	0 - 86400
OC12-4.pmthresholds.sts12c.nearend.1day.PPJC-PDET	5760 (count)	0 - 691200000
OC12-4.pmthresholds.sts12c.nearend.1day.PPJC-PGEN	5760 (count)	0 - 691200000
OC12-4.pmthresholds.sts12c.nearend.1day.SES	7 (seconds)	0 - 86400
OC12-4.pmthresholds.sts12c.nearend.1day.UAS	10 (seconds)	0 - 86400
OC12-4.pmthresholds.sts3c-9c.nearend.15min.CV	25 (B3 count)	0 - 2160000
OC12-4.pmthresholds.sts3c-9c.nearend.15min.ES	20 (seconds)	0 - 900
OC12-4.pmthresholds.sts3c-9c.nearend.15min.FC	10 (count)	0 - 72
OC12-4.pmthresholds.sts3c-9c.nearend.15min.NPJC-PDET	60 (count)	0 - 7200000
OC12-4.pmthresholds.sts3c-9c.nearend.15min.NPJC-PGEN	60 (count)	0 - 7200000
OC12-4.pmthresholds.sts3c-9c.nearend.15min.PJCDIFF	60 (count)	0 - 14400000
OC12-4.pmthresholds.sts3c-9c.nearend.15min.PJCS-PDET	100 (seconds)	0 - 900
OC12-4.pmthresholds.sts3c-9c.nearend.15min.PJCS-PGEN	100 (seconds)	0 - 900
OC12-4.pmthresholds.sts3c-9c.nearend.15min.PPJC-PDET	60 (count)	0 - 7200000
OC12-4.pmthresholds.sts3c-9c.nearend.15min.PPJC-PGEN	60 (count)	0 - 7200000
OC12-4.pmthresholds.sts3c-9c.nearend.15min.SES	3 (seconds)	0 - 900
OC12-4.pmthresholds.sts3c-9c.nearend.15min.UAS	10 (seconds)	0 - 900
OC12-4.pmthresholds.sts3c-9c.nearend.1day.CV	250 (B3 count)	0 - 207360000
OC12-4.pmthresholds.sts3c-9c.nearend.1day.ES	200 (seconds)	0 - 86400
OC12-4.pmthresholds.sts3c-9c.nearend.1day.FC	40 (count)	0 - 6912
OC12-4.pmthresholds.sts3c-9c.nearend.1day.NPJC-PDET	5760 (count)	0 - 691200000
OC12-4.pmthresholds.sts3c-9c.nearend.1day.NPJC-PGEN	5760 (count)	0 - 691200000

Table C-15 OC12-4 Card Default Settings (continued)

Default Name	Default Value	Default Domain
OC12-4.pmthresholds.sts3c-9c.nearend.1day.PJCDIFF	5760 (count)	0 - 1382400000
OC12-4.pmthresholds.sts3c-9c.nearend.1day.PJCS-PDET	9600 (seconds)	0 - 86400
OC12-4.pmthresholds.sts3c-9c.nearend.1day.PJCS-PGEN	9600 (seconds)	0 - 86400
OC12-4.pmthresholds.sts3c-9c.nearend.1day.PPJC-PDET	5760 (count)	0 - 691200000
OC12-4.pmthresholds.sts3c-9c.nearend.1day.PPJC-PGEN	5760 (count)	0 - 691200000
OC12-4.pmthresholds.sts3c-9c.nearend.1day.SES	7 (seconds)	0 - 86400
OC12-4.pmthresholds.sts3c-9c.nearend.1day.UAS	10 (seconds)	0 - 86400

C.2.3.16 OC-48 Card Default Settings

Table C-16 lists the OC-48 (OC48 IR 1310, OC48 LR 1550, OC48 IR/STM16 SH AS 1310, OC48 LR/STM16 LH AS 1550, OC48 ELR/STM16 EH 100 GHz, and OC48 ELR 200 GHz) card default settings.

Table C-16 OC-48 Card Default Settings

Default Name	Default Value	Default Domain
OC48.config.line.AdminSSMIn	STU	PRS, STU, ST2, TNC, ST3E, ST3, SMC, ST4, DUS, RES
OC48.config.line.AINSSoakTime	08:00 (hours:mins)	00:00, 00:15, 00:30 .. 48:00
OC48.config.line.AlsMode	Disabled	Disabled, Auto Restart, Manual Restart, Manual Restart for Test
OC48.config.line.AlsRecoveryPulseDuration	2.0 (seconds)	2.0, 2.1, 2.2 .. 100.0 when AlsMode Disabled, Auto Restart, Manual Restart; 80.0, 80.1, 80.2 .. 100.0 when AlsMode Manual Restart for Test
OC48.config.line.AlsRecoveryPulseInterval	100 (seconds)	60 - 300
OC48.config.line.PJStsMon#	0 (STS #)	0 - 48
OC48.config.line.SDBER	1E-7	1E-5, 1E-6, 1E-7, 1E-8, 1E-9
OC48.config.line.Send<FF>DoNotUse	FALSE	FALSE when SendDoNotUse TRUE; FALSE, TRUE when SendDoNotUse FALSE
OC48.config.line.SendDoNotUse	FALSE	FALSE, TRUE
OC48.config.line.SFBER	1E-4	1E-3, 1E-4, 1E-5
OC48.config.line.State	IS,AINS	IS, OOS,DSBLD, OOS,MT, IS,AINS
OC48.config.line.SyncMsgIn	TRUE	FALSE, TRUE
OC48.config.sts.IPPMEnabled	FALSE	TRUE, FALSE
OC48.pmthresholds.line.farend.15min.CV	21260 (B2 count)	0 - 2212200
OC48.pmthresholds.line.farend.15min.ES	87 (seconds)	0 - 900
OC48.pmthresholds.line.farend.15min.FC	10 (count)	0 - 72

Table C-16 OC-48 Card Default Settings (continued)

Default Name	Default Value	Default Domain
OC48.pmthresholds.line.farend.15min.SES	1 (seconds)	0 - 900
OC48.pmthresholds.line.farend.15min.UAS	3 (seconds)	0 - 900
OC48.pmthresholds.line.farend.1day.CV	212600 (B2 count)	0 - 212371200
OC48.pmthresholds.line.farend.1day.ES	864 (seconds)	0 - 86400
OC48.pmthresholds.line.farend.1day.FC	40 (count)	0 - 6912
OC48.pmthresholds.line.farend.1day.SES	4 (seconds)	0 - 86400
OC48.pmthresholds.line.farend.1day.UAS	10 (seconds)	0 - 86400
OC48.pmthresholds.line.nearend.15min.CV	21260 (B2 count)	0 - 2212200
OC48.pmthresholds.line.nearend.15min.ES	87 (seconds)	0 - 900
OC48.pmthresholds.line.nearend.15min.FC	10 (count)	0 - 72
OC48.pmthresholds.line.nearend.15min.PSC	1 (count)	0 - 600
OC48.pmthresholds.line.nearend.15min.PSC-R	1 (count)	0 - 600
OC48.pmthresholds.line.nearend.15min.PSC-S	1 (count)	0 - 600
OC48.pmthresholds.line.nearend.15min.PSC-W	1 (count)	0 - 600
OC48.pmthresholds.line.nearend.15min.PSD	300 (seconds)	0 - 900
OC48.pmthresholds.line.nearend.15min.PSD-R	300 (seconds)	0 - 900
OC48.pmthresholds.line.nearend.15min.PSD-S	300 (seconds)	0 - 900
OC48.pmthresholds.line.nearend.15min.PSD-W	300 (seconds)	0 - 900
OC48.pmthresholds.line.nearend.15min.SES	1 (seconds)	0 - 900
OC48.pmthresholds.line.nearend.15min.UAS	3 (seconds)	0 - 900
OC48.pmthresholds.line.nearend.1day.CV	212600 (B2 count)	0 - 212371200
OC48.pmthresholds.line.nearend.1day.ES	864 (seconds)	0 - 86400
OC48.pmthresholds.line.nearend.1day.FC	40 (count)	0 - 6912
OC48.pmthresholds.line.nearend.1day.PSC	5 (count)	0 - 57600
OC48.pmthresholds.line.nearend.1day.PSC-R	5 (count)	0 - 57600
OC48.pmthresholds.line.nearend.1day.PSC-S	5 (count)	0 - 57600
OC48.pmthresholds.line.nearend.1day.PSC-W	5 (count)	0 - 57600
OC48.pmthresholds.line.nearend.1day.PSD	600 (seconds)	0 - 86400
OC48.pmthresholds.line.nearend.1day.PSD-R	600 (seconds)	0 - 86400
OC48.pmthresholds.line.nearend.1day.PSD-S	600 (seconds)	0 - 86400
OC48.pmthresholds.line.nearend.1day.PSD-W	600 (seconds)	0 - 86400
OC48.pmthresholds.line.nearend.1day.SES	4 (seconds)	0 - 86400
OC48.pmthresholds.line.nearend.1day.UAS	10 (seconds)	0 - 86400
OC48.pmthresholds.section.nearend.15min.CV	10000 (B1 count)	0 - 2151900
OC48.pmthresholds.section.nearend.15min.ES	500 (seconds)	0 - 900
OC48.pmthresholds.section.nearend.15min.SEFS	500 (seconds)	0 - 900

Table C-16 OC-48 Card Default Settings (continued)

Default Name	Default Value	Default Domain
OC48.pmthresholds.section.nearend.15min.SES	500 (seconds)	0 - 900
OC48.pmthresholds.section.nearend.1day.CV	100000 (B1 count)	0 - 206582400
OC48.pmthresholds.section.nearend.1day.ES	5000 (seconds)	0 - 86400
OC48.pmthresholds.section.nearend.1day.SEFS	5000 (seconds)	0 - 86400
OC48.pmthresholds.section.nearend.1day.SES	5000 (seconds)	0 - 86400
OC48.pmthresholds.sts1.nearend.15min.CV	15 (B3 count)	0 - 2160000
OC48.pmthresholds.sts1.nearend.15min.ES	12 (seconds)	0 - 900
OC48.pmthresholds.sts1.nearend.15min.FC	10 (count)	0 - 72
OC48.pmthresholds.sts1.nearend.15min.NPJC-PDET	60 (count)	0 - 7200000
OC48.pmthresholds.sts1.nearend.15min.NPJC-PGEN	60 (count)	0 - 7200000
OC48.pmthresholds.sts1.nearend.15min.PJCDIFF	60 (count)	0 - 14400000
OC48.pmthresholds.sts1.nearend.15min.PJCS-PDET	100 (seconds)	0 - 900
OC48.pmthresholds.sts1.nearend.15min.PJCS-PGEN	100 (seconds)	0 - 900
OC48.pmthresholds.sts1.nearend.15min.PPJC-PDET	60 (count)	0 - 7200000
OC48.pmthresholds.sts1.nearend.15min.PPJC-PGEN	60 (count)	0 - 7200000
OC48.pmthresholds.sts1.nearend.15min.SES	3 (seconds)	0 - 900
OC48.pmthresholds.sts1.nearend.15min.UAS	10 (seconds)	0 - 900
OC48.pmthresholds.sts1.nearend.1day.CV	125 (B3 count)	0 - 207360000
OC48.pmthresholds.sts1.nearend.1day.ES	100 (seconds)	0 - 86400
OC48.pmthresholds.sts1.nearend.1day.FC	40 (count)	0 - 6912
OC48.pmthresholds.sts1.nearend.1day.NPJC-PDET	5760 (count)	0 - 691200000
OC48.pmthresholds.sts1.nearend.1day.NPJC-PGEN	5760 (count)	0 - 691200000
OC48.pmthresholds.sts1.nearend.1day.PJCDIFF	5760 (count)	0 - 1382400000
OC48.pmthresholds.sts1.nearend.1day.PJCS-PDET	9600 (seconds)	0 - 86400
OC48.pmthresholds.sts1.nearend.1day.PJCS-PGEN	9600 (seconds)	0 - 86400
OC48.pmthresholds.sts1.nearend.1day.PPJC-PDET	5760 (count)	0 - 691200000
OC48.pmthresholds.sts1.nearend.1day.PPJC-PGEN	5760 (count)	0 - 691200000
OC48.pmthresholds.sts1.nearend.1day.SES	7 (seconds)	0 - 86400
OC48.pmthresholds.sts1.nearend.1day.UAS	10 (seconds)	0 - 86400
OC48.pmthresholds.sts12c-48c.nearend.15min.CV	75 (B3 count)	0 - 2160000
OC48.pmthresholds.sts12c-48c.nearend.15min.ES	60 (seconds)	0 - 900
OC48.pmthresholds.sts12c-48c.nearend.15min.FC	10 (count)	0 - 72
OC48.pmthresholds.sts12c-48c.nearend.15min.NPJC-PDET	60 (count)	0 - 7200000
OC48.pmthresholds.sts12c-48c.nearend.15min.NPJC-PGEN	60 (count)	0 - 7200000
OC48.pmthresholds.sts12c-48c.nearend.15min.PJCDIFF	60 (count)	0 - 14400000
OC48.pmthresholds.sts12c-48c.nearend.15min.PJCS-PDET	100 (seconds)	0 - 900

Table C-16 OC-48 Card Default Settings (continued)

Default Name	Default Value	Default Domain
OC48.pmthresholds.sts12c-48c.nearend.15min.PJCS-PGEN	100 (seconds)	0 - 900
OC48.pmthresholds.sts12c-48c.nearend.15min.PPJC-PDET	60 (count)	0 - 7200000
OC48.pmthresholds.sts12c-48c.nearend.15min.PPJC-PGEN	60 (count)	0 - 7200000
OC48.pmthresholds.sts12c-48c.nearend.15min.SES	3 (seconds)	0 - 900
OC48.pmthresholds.sts12c-48c.nearend.15min.UAS	10 (seconds)	0 - 900
OC48.pmthresholds.sts12c-48c.nearend.1day.CV	750 (B3 count)	0 - 207360000
OC48.pmthresholds.sts12c-48c.nearend.1day.ES	600 (seconds)	0 - 86400
OC48.pmthresholds.sts12c-48c.nearend.1day.FC	40 (count)	0 - 6912
OC48.pmthresholds.sts12c-48c.nearend.1day.NPJC-PDET	5760 (count)	0 - 691200000
OC48.pmthresholds.sts12c-48c.nearend.1day.NPJC-PGEN	5760 (count)	0 - 691200000
OC48.pmthresholds.sts12c-48c.nearend.1day.PJCDIFF	5760 (count)	0 - 1382400000
OC48.pmthresholds.sts12c-48c.nearend.1day.PJCS-PDET	9600 (seconds)	0 - 86400
OC48.pmthresholds.sts12c-48c.nearend.1day.PJCS-PGEN	9600 (seconds)	0 - 86400
OC48.pmthresholds.sts12c-48c.nearend.1day.PPJC-PDET	5760 (count)	0 - 691200000
OC48.pmthresholds.sts12c-48c.nearend.1day.PPJC-PGEN	5760 (count)	0 - 691200000
OC48.pmthresholds.sts12c-48c.nearend.1day.SES	7 (seconds)	0 - 86400
OC48.pmthresholds.sts12c-48c.nearend.1day.UAS	10 (seconds)	0 - 86400
OC48.pmthresholds.sts3c-9c.nearend.15min.CV	25 (B3 count)	0 - 2160000
OC48.pmthresholds.sts3c-9c.nearend.15min.ES	20 (seconds)	0 - 900
OC48.pmthresholds.sts3c-9c.nearend.15min.FC	10 (count)	0 - 72
OC48.pmthresholds.sts3c-9c.nearend.15min.NPJC-PDET	60 (count)	0 - 7200000
OC48.pmthresholds.sts3c-9c.nearend.15min.NPJC-PGEN	60 (count)	0 - 7200000
OC48.pmthresholds.sts3c-9c.nearend.15min.PJCDIFF	60 (count)	0 - 14400000
OC48.pmthresholds.sts3c-9c.nearend.15min.PJCS-PDET	100 (seconds)	0 - 900
OC48.pmthresholds.sts3c-9c.nearend.15min.PJCS-PGEN	100 (seconds)	0 - 900
OC48.pmthresholds.sts3c-9c.nearend.15min.PPJC-PDET	60 (count)	0 - 7200000
OC48.pmthresholds.sts3c-9c.nearend.15min.PPJC-PGEN	60 (count)	0 - 7200000
OC48.pmthresholds.sts3c-9c.nearend.15min.SES	3 (seconds)	0 - 900
OC48.pmthresholds.sts3c-9c.nearend.15min.UAS	10 (seconds)	0 - 900
OC48.pmthresholds.sts3c-9c.nearend.1day.CV	250 (B3 count)	0 - 207360000
OC48.pmthresholds.sts3c-9c.nearend.1day.ES	200 (seconds)	0 - 86400
OC48.pmthresholds.sts3c-9c.nearend.1day.FC	40 (count)	0 - 6912
OC48.pmthresholds.sts3c-9c.nearend.1day.NPJC-PDET	5760 (count)	0 - 691200000
OC48.pmthresholds.sts3c-9c.nearend.1day.NPJC-PGEN	5760 (count)	0 - 691200000
OC48.pmthresholds.sts3c-9c.nearend.1day.PJCDIFF	5760 (count)	0 - 1382400000
OC48.pmthresholds.sts3c-9c.nearend.1day.PJCS-PDET	9600 (seconds)	0 - 86400

Table C-16 OC-48 Card Default Settings (continued)

Default Name	Default Value	Default Domain
OC48.pmthresholds.sts3c-9c.nearend.1day.PJCS-PGEN	9600 (seconds)	0 - 86400
OC48.pmthresholds.sts3c-9c.nearend.1day.PPJC-PDET	5760 (count)	0 - 691200000
OC48.pmthresholds.sts3c-9c.nearend.1day.PPJC-PGEN	5760 (count)	0 - 691200000
OC48.pmthresholds.sts3c-9c.nearend.1day.SES	7 (seconds)	0 - 86400
OC48.pmthresholds.sts3c-9c.nearend.1day.UAS	10 (seconds)	0 - 86400

C.2.3.17 OC-192 Card Default Settings

[Table C-17](#) lists the OC-192 (OC192 SR/STM64 IO 1310, OC192 LR/STM64 LH ITU 15xx.xx, OC192 IR/STM64 SH 1550, and OC192 LR/STM64 LH 1550) card default settings.

Table C-17 OC-192 Card Default Settings

Default Name	Default Value	Default Domain
OC192.config.line.AdminSSMIn	STU	PRS, STU, ST2, TNC, ST3E, ST3, SMC, ST4, DUS, RES
OC192.config.line.AINSSoakTime	08:00 (hours:mins)	00:00, 00:15, 00:30 .. 48:00
OC192.config.line.AlsMode	Disabled	Disabled, Auto Restart, Manual Restart, Manual Restart for Test
OC192.config.line.AlsRecoveryPulseDuration	2.0 (seconds)	2.0, 2.1, 2.2 .. 100.0 when AlsMode Disabled, Auto Restart, Manual Restart; 80.0, 80.1, 80.2 .. 100.0 when AlsMode Manual Restart for Test
OC192.config.line.AlsRecoveryPulseInterval	100 (seconds)	60 - 300
OC192.config.line.PJStsMon#	0 (STS #)	0 - 192
OC192.config.line.SDBER	1E-7	1E-5, 1E-6, 1E-7, 1E-8, 1E-9
OC192.config.line.Send<FF>DoNotUse	FALSE	FALSE when SendDoNotUse TRUE; FALSE, TRUE when SendDoNotUse FALSE
OC192.config.line.SendDoNotUse	FALSE	FALSE, TRUE
OC192.config.line.SFBER	1E-4	1E-3, 1E-4, 1E-5
OC192.config.line.State	IS,AINS	IS, OOS,DSBLD, OOS,MT, IS,AINS
OC192.config.line.SyncMsgIn	TRUE	FALSE, TRUE
OC192.config.sts.IPPMEnabled	FALSE	TRUE, FALSE
OC192.physicalthresholds.alarm.LBC-HIGH	200 (%)	LBC-LOW, LBC-LOW + 1.0, LBC-LOW + 2.0 .. 255.0
OC192.physicalthresholds.alarm.LBC-LOW	20 (%)	0.0, 1.0, 2.0 .. LBC-HIGH
OC192.physicalthresholds.alarm.OPR-HIGH	200 (%)	OPR-LOW, OPR-LOW + 1.0, OPR-LOW + 2.0 .. 255.0

Table C-17 OC-192 Card Default Settings (continued)

Default Name	Default Value	Default Domain
OC192.physicalthresholds.alarm.OPR-LOW	50 (%)	0.0, 1.0, 2.0 .. OPR-HIGH
OC192.physicalthresholds.alarm.OPT-HIGH	120 (%)	OPT-LOW, OPT-LOW + 1.0, OPT-LOW + 2.0 .. 255.0
OC192.physicalthresholds.alarm.OPT-LOW	80 (%)	0.0, 1.0, 2.0 .. OPT-HIGH
OC192.physicalthresholds.warning.15min.LBC-HIGH	200 (%)	LBC-LOW, LBC-LOW + 1.0, LBC-LOW + 2.0 .. 255.0
OC192.physicalthresholds.warning.15min.LBC-LOW	20 (%)	0.0, 1.0, 2.0 .. LBC-HIGH
OC192.physicalthresholds.warning.15min.OPR-HIGH	200 (%)	OPR-LOW, OPR-LOW + 1.0, OPR-LOW + 2.0 .. 255.0
OC192.physicalthresholds.warning.15min.OPR-LOW	50 (%)	0.0, 1.0, 2.0 .. OPR-HIGH
OC192.physicalthresholds.warning.15min.OPT-HIGH	120 (%)	OPT-LOW, OPT-LOW + 1.0, OPT-LOW + 2.0 .. 255.0
OC192.physicalthresholds.warning.15min.OPT-LOW	80 (%)	0.0, 1.0, 2.0 .. OPT-HIGH
OC192.physicalthresholds.warning.1day.LBC-HIGH	200 (%)	LBC-LOW, LBC-LOW + 1.0, LBC-LOW + 2.0 .. 255.0
OC192.physicalthresholds.warning.1day.LBC-LOW	20 (%)	0.0, 1.0, 2.0 .. LBC-HIGH
OC192.physicalthresholds.warning.1day.OPR-HIGH	200 (%)	OPR-LOW, OPR-LOW + 1.0, OPR-LOW + 2.0 .. 255.0
OC192.physicalthresholds.warning.1day.OPR-LOW	50 (%)	0.0, 1.0, 2.0 .. OPR-HIGH
OC192.physicalthresholds.warning.1day.OPT-HIGH	120 (%)	OPT-LOW, OPT-LOW + 1.0, OPT-LOW + 2.0 .. 255.0
OC192.physicalthresholds.warning.1day.OPT-LOW	80 (%)	0.0, 1.0, 2.0 .. OPT-HIGH
OC192.pmthresholds.line.farend.15min.CV	85040 (B2 count)	0 - 8850600
OC192.pmthresholds.line.farend.15min.ES	87 (seconds)	0 - 900
OC192.pmthresholds.line.farend.15min.FC	10 (count)	0 - 72
OC192.pmthresholds.line.farend.15min.SES	1 (seconds)	0 - 900
OC192.pmthresholds.line.farend.15min.UAS	3 (seconds)	0 - 900
OC192.pmthresholds.line.farend.1day.CV	850400 (B2 count)	0 - 849657600
OC192.pmthresholds.line.farend.1day.ES	864 (seconds)	0 - 86400
OC192.pmthresholds.line.farend.1day.FC	40 (count)	0 - 6912
OC192.pmthresholds.line.farend.1day.SES	4 (seconds)	0 - 86400
OC192.pmthresholds.line.farend.1day.UAS	10 (seconds)	0 - 86400
OC192.pmthresholds.line.nearend.15min.CV	85040 (B2 count)	0 - 8850600
OC192.pmthresholds.line.nearend.15min.ES	87 (seconds)	0 - 900
OC192.pmthresholds.line.nearend.15min.FC	10 (count)	0 - 72
OC192.pmthresholds.line.nearend.15min.PSC	1 (count)	0 - 600
OC192.pmthresholds.line.nearend.15min.PSC-R	1 (count)	0 - 600
OC192.pmthresholds.line.nearend.15min.PSC-S	1 (count)	0 - 600

Table C-17 OC-192 Card Default Settings (continued)

Default Name	Default Value	Default Domain
OC192.pmthresholds.line.nearend.15min.PSC-W	1 (count)	0 - 600
OC192.pmthresholds.line.nearend.15min.PSD	300 (seconds)	0 - 900
OC192.pmthresholds.line.nearend.15min.PSD-R	300 (seconds)	0 - 900
OC192.pmthresholds.line.nearend.15min.PSD-S	300 (seconds)	0 - 900
OC192.pmthresholds.line.nearend.15min.PSD-W	300 (seconds)	0 - 900
OC192.pmthresholds.line.nearend.15min.SES	1 (seconds)	0 - 900
OC192.pmthresholds.line.nearend.15min.UAS	3 (seconds)	0 - 900
OC192.pmthresholds.line.nearend.1day.CV	850400 (B2 count)	0 - 849657600
OC192.pmthresholds.line.nearend.1day.ES	864 (seconds)	0 - 86400
OC192.pmthresholds.line.nearend.1day.FC	40 (count)	0 - 6912
OC192.pmthresholds.line.nearend.1day.PSC	5 (count)	0 - 57600
OC192.pmthresholds.line.nearend.1day.PSC-R	5 (count)	0 - 57600
OC192.pmthresholds.line.nearend.1day.PSC-S	5 (count)	0 - 57600
OC192.pmthresholds.line.nearend.1day.PSC-W	5 (count)	0 - 57600
OC192.pmthresholds.line.nearend.1day.PSD	600 (seconds)	0 - 86400
OC192.pmthresholds.line.nearend.1day.PSD-R	600 (seconds)	0 - 86400
OC192.pmthresholds.line.nearend.1day.PSD-S	600 (seconds)	0 - 86400
OC192.pmthresholds.line.nearend.1day.PSD-W	600 (seconds)	0 - 86400
OC192.pmthresholds.line.nearend.1day.SES	4 (seconds)	0 - 86400
OC192.pmthresholds.line.nearend.1day.UAS	10 (seconds)	0 - 86400
OC192.pmthresholds.section.nearend.15min.CV	10000 (B1 count)	0 - 7967700
OC192.pmthresholds.section.nearend.15min.ES	500 (seconds)	0 - 900
OC192.pmthresholds.section.nearend.15min.SEFS	500 (seconds)	0 - 900
OC192.pmthresholds.section.nearend.15min.SES	500 (seconds)	0 - 900
OC192.pmthresholds.section.nearend.1day.CV	100000 (B1 count)	0 - 764899200
OC192.pmthresholds.section.nearend.1day.ES	5000 (seconds)	0 - 86400
OC192.pmthresholds.section.nearend.1day.SEFS	5000 (seconds)	0 - 86400
OC192.pmthresholds.section.nearend.1day.SES	5000 (seconds)	0 - 86400
OC192.pmthresholds.sts1.nearend.15min.CV	15 (B3 count)	0 - 2160000
OC192.pmthresholds.sts1.nearend.15min.ES	12 (seconds)	0 - 900
OC192.pmthresholds.sts1.nearend.15min.FC	10 (count)	0 - 72
OC192.pmthresholds.sts1.nearend.15min.NPJC-PDET	60 (count)	0 - 7200000
OC192.pmthresholds.sts1.nearend.15min.NPJC-PGEN	60 (count)	0 - 7200000
OC192.pmthresholds.sts1.nearend.15min.PJCDIFF	60 (count)	0 - 14400000
OC192.pmthresholds.sts1.nearend.15min.PJCS-PDET	100 (seconds)	0 - 900
OC192.pmthresholds.sts1.nearend.15min.PJCS-PGEN	100 (seconds)	0 - 900

Table C-17 OC-192 Card Default Settings (continued)

Default Name	Default Value	Default Domain
OC192.pmthresholds.sts1.nearend.15min.PPJC-PDET	60 (count)	0 - 7200000
OC192.pmthresholds.sts1.nearend.15min.PPJC-PGEN	60 (count)	0 - 7200000
OC192.pmthresholds.sts1.nearend.15min.SES	3 (seconds)	0 - 900
OC192.pmthresholds.sts1.nearend.15min.UAS	10 (seconds)	0 - 900
OC192.pmthresholds.sts1.nearend.1day.CV	125 (B3 count)	0 - 207360000
OC192.pmthresholds.sts1.nearend.1day.ES	100 (seconds)	0 - 86400
OC192.pmthresholds.sts1.nearend.1day.FC	40 (count)	0 - 6912
OC192.pmthresholds.sts1.nearend.1day.NPJC-PDET	5760 (count)	0 - 691200000
OC192.pmthresholds.sts1.nearend.1day.NPJC-PGEN	5760 (count)	0 - 691200000
OC192.pmthresholds.sts1.nearend.1day.PJCDIFF	5760 (count)	0 - 1382400000
OC192.pmthresholds.sts1.nearend.1day.PJCS-PDET	9600 (seconds)	0 - 86400
OC192.pmthresholds.sts1.nearend.1day.PJCS-PGEN	9600 (seconds)	0 - 86400
OC192.pmthresholds.sts1.nearend.1day.PPJC-PDET	5760 (count)	0 - 691200000
OC192.pmthresholds.sts1.nearend.1day.PPJC-PGEN	5760 (count)	0 - 691200000
OC192.pmthresholds.sts1.nearend.1day.SES	7 (seconds)	0 - 86400
OC192.pmthresholds.sts1.nearend.1day.UAS	10 (seconds)	0 - 86400
OC192.pmthresholds.sts12c-192c.nearend.15min.CV	75 (B3 count)	0 - 2160000
OC192.pmthresholds.sts12c-192c.nearend.15min.ES	60 (seconds)	0 - 900
OC192.pmthresholds.sts12c-192c.nearend.15min.FC	10 (count)	0 - 72
OC192.pmthresholds.sts12c-192c.nearend.15min.NPJC-PDET	60 (count)	0 - 7200000
OC192.pmthresholds.sts12c-192c.nearend.15min.NPJC-PGEN	60 (count)	0 - 7200000
OC192.pmthresholds.sts12c-192c.nearend.15min.PJCDIFF	60 (count)	0 - 14400000
OC192.pmthresholds.sts12c-192c.nearend.15min.PJCS-PDET	100 (seconds)	0 - 900
OC192.pmthresholds.sts12c-192c.nearend.15min.PJCS-PGEN	100 (seconds)	0 - 900
OC192.pmthresholds.sts12c-192c.nearend.15min.PPJC-PDET	60 (count)	0 - 7200000
OC192.pmthresholds.sts12c-192c.nearend.15min.PPJC-PGEN	60 (count)	0 - 7200000
OC192.pmthresholds.sts12c-192c.nearend.15min.SES	3 (seconds)	0 - 900
OC192.pmthresholds.sts12c-192c.nearend.15min.UAS	10 (seconds)	0 - 900
OC192.pmthresholds.sts12c-192c.nearend.1day.CV	750 (B3 count)	0 - 207360000
OC192.pmthresholds.sts12c-192c.nearend.1day.ES	600 (seconds)	0 - 86400
OC192.pmthresholds.sts12c-192c.nearend.1day.FC	40 (count)	0 - 6912
OC192.pmthresholds.sts12c-192c.nearend.1day.NPJC-PDET	5760 (count)	0 - 691200000
OC192.pmthresholds.sts12c-192c.nearend.1day.NPJC-PGEN	5760 (count)	0 - 691200000
OC192.pmthresholds.sts12c-192c.nearend.1day.PJCDIFF	5760 (count)	0 - 1382400000
OC192.pmthresholds.sts12c-192c.nearend.1day.PJCS-PDET	9600 (seconds)	0 - 691200000
OC192.pmthresholds.sts12c-192c.nearend.1day.PJCS-PGEN	9600 (seconds)	0 - 86400

Table C-17 OC-192 Card Default Settings (continued)

Default Name	Default Value	Default Domain
OC192.pmthresholds.sts12c-192c.nearend.1day.PPJC-PDET	5760 (count)	0 - 691200000
OC192.pmthresholds.sts12c-192c.nearend.1day.PPJC-PGEN	5760 (count)	0 - 691200000
OC192.pmthresholds.sts12c-192c.nearend.1day.SES	7 (seconds)	0 - 86400
OC192.pmthresholds.sts12c-192c.nearend.1day.UAS	10 (seconds)	0 - 86400
OC192.pmthresholds.sts3c-9c.nearend.15min.CV	25 (B3 count)	0 - 2160000
OC192.pmthresholds.sts3c-9c.nearend.15min.ES	20 (seconds)	0 - 900
OC192.pmthresholds.sts3c-9c.nearend.15min.FC	10 (count)	0 - 72
OC192.pmthresholds.sts3c-9c.nearend.15min.NPJC-PDET	60 (count)	0 - 7200000
OC192.pmthresholds.sts3c-9c.nearend.15min.NPJC-PGEN	60 (count)	0 - 7200000
OC192.pmthresholds.sts3c-9c.nearend.15min.PJCDIFF	60 (count)	0 - 14400000
OC192.pmthresholds.sts3c-9c.nearend.15min.PJCS-PDET	100 (seconds)	0 - 900
OC192.pmthresholds.sts3c-9c.nearend.15min.PJCS-PGEN	100 (seconds)	0 - 900
OC192.pmthresholds.sts3c-9c.nearend.15min.PPJC-PDET	60 (count)	0 - 7200000
OC192.pmthresholds.sts3c-9c.nearend.15min.PPJC-PGEN	60 (count)	0 - 7200000
OC192.pmthresholds.sts3c-9c.nearend.15min.SES	3 (seconds)	0 - 900
OC192.pmthresholds.sts3c-9c.nearend.15min.UAS	10 (seconds)	0 - 900
OC192.pmthresholds.sts3c-9c.nearend.1day.CV	250 (B3 count)	0 - 207360000
OC192.pmthresholds.sts3c-9c.nearend.1day.ES	200 (seconds)	0 - 86400
OC192.pmthresholds.sts3c-9c.nearend.1day.FC	40 (count)	0 - 6912
OC192.pmthresholds.sts3c-9c.nearend.1day.NPJC-PDET	5760 (count)	0 - 691200000
OC192.pmthresholds.sts3c-9c.nearend.1day.NPJC-PGEN	5760 (count)	0 - 691200000
OC192.pmthresholds.sts3c-9c.nearend.1day.PJCDIFF	5760 (count)	0 - 1382400000
OC192.pmthresholds.sts3c-9c.nearend.1day.PJCS-PDET	9600 (seconds)	0 - 86400
OC192.pmthresholds.sts3c-9c.nearend.1day.PJCS-PGEN	9600 (seconds)	0 - 86400
OC192.pmthresholds.sts3c-9c.nearend.1day.PPJC-PDET	5760 (count)	0 - 691200000
OC192.pmthresholds.sts3c-9c.nearend.1day.PPJC-PGEN	5760 (count)	0 - 691200000
OC192.pmthresholds.sts3c-9c.nearend.1day.SES	7 (seconds)	0 - 86400
OC192.pmthresholds.sts3c-9c.nearend.1day.UAS	10 (seconds)	0 - 86400

C.2.3.18 OC192-XFP Default Settings

Table C-18 lists the OC192-XFP default settings.

Table C-18 OC192-XFP Default Settings

Default Name	Default Value	Default Domain
OC192-XFP.config.line.AINSSoakTime	08:00 (hours:mins)	00:00, 00:15, 00:30 .. 48:00
OC192-XFP.config.line.AlsMode	Disabled	Disabled, Auto Restart, Manual Restart, Manual Restart for Test
OC192-XFP.config.line.AlsRecoveryPulseDuration	2.0 (seconds)	2.0, 2.1, 2.2 .. 100.0 when AlsMode Disabled, Auto Restart, Manual Restart; 80.0, 80.1, 80.2 .. 100.0 when AlsMode Manual Restart for Test
OC192-XFP.config.line.AlsRecoveryPulseInterval	100 (seconds)	60 - 300
OC192-XFP.config.line.PJStsMon#	0 (STS #)	0 - 192
OC192-XFP.config.line.SDBER	1E-7	1E-5, 1E-6, 1E-7, 1E-8, 1E-9
OC192-XFP.config.line.Send<FF>DoNotUse	FALSE	FALSE when SendDoNotUse TRUE; FALSE, TRUE when SendDoNotUse FALSE
OC192-XFP.config.line.SendDoNotUse	FALSE	FALSE, TRUE
OC192-XFP.config.line.SFBER	1E-4	1E-3, 1E-4, 1E-5
OC192-XFP.config.line.State	IS,AINS	IS, OOS,DSBLD, OOS,MT, IS,AINS
OC192-XFP.config.line.SyncMsgIn	TRUE	FALSE, TRUE
OC192-XFP.config.sts.IPPMEnabled	FALSE	TRUE, FALSE
OC192-XFP.physicalthresholds.alarm.LBC-HIGH	200 (%)	LBC-LOW, LBC-LOW + 1.0, LBC-LOW + 2.0 .. 255.0
OC192-XFP.physicalthresholds.alarm.LBC-LOW	20 (%)	0.0, 1.0, 2.0 .. LBC-HIGH
OC192-XFP.physicalthresholds.alarm.OPR-HIGH	200 (%)	OPR-LOW, OPR-LOW + 1.0, OPR-LOW + 2.0 .. 255.0
OC192-XFP.physicalthresholds.alarm.OPR-LOW	50 (%)	0.0, 1.0, 2.0 .. OPR-HIGH
OC192-XFP.physicalthresholds.alarm.OPT-HIGH	120 (%)	OPT-LOW, OPT-LOW + 1.0, OPT-LOW + 2.0 .. 255.0
OC192-XFP.physicalthresholds.alarm.OPT-LOW	80 (%)	0.0, 1.0, 2.0 .. OPT-HIGH
OC192-XFP.physicalthresholds.warning.15min.LBC-HIGH	200 (%)	LBC-LOW, LBC-LOW + 1.0, LBC-LOW + 2.0 .. 255.0
OC192-XFP.physicalthresholds.warning.15min.LBC-LOW	20 (%)	0.0, 1.0, 2.0 .. LBC-HIGH
OC192-XFP.physicalthresholds.warning.15min.OPR-HIGH	200 (%)	OPR-LOW, OPR-LOW + 1.0, OPR-LOW + 2.0 .. 255.0
OC192-XFP.physicalthresholds.warning.15min.OPR-LOW	50 (%)	0.0, 1.0, 2.0 .. OPR-HIGH
OC192-XFP.physicalthresholds.warning.15min.OPT-HIGH	120 (%)	OPT-LOW, OPT-LOW + 1.0, OPT-LOW + 2.0 .. 255.0
OC192-XFP.physicalthresholds.warning.15min.OPT-LOW	80 (%)	0.0, 1.0, 2.0 .. OPT-HIGH

Table C-18 OC192-XFP Default Settings (continued)

Default Name	Default Value	Default Domain
OC192-XFP.physicalthresholds.warning.1day.LBC-HIGH	200 (%)	LBC-LOW, LBC-LOW + 1.0, LBC-LOW + 2.0 .. 255.0
OC192-XFP.physicalthresholds.warning.1day.LBC-LOW	20 (%)	0.0, 1.0, 2.0 .. LBC-HIGH
OC192-XFP.physicalthresholds.warning.1day.OPR-HIGH	200 (%)	OPR-LOW, OPR-LOW + 1.0, OPR-LOW + 2.0 .. 255.0
OC192-XFP.physicalthresholds.warning.1day.OPR-LOW	50 (%)	0.0, 1.0, 2.0 .. OPR-HIGH
OC192-XFP.physicalthresholds.warning.1day.OPT-HIGH	120 (%)	OPT-LOW, OPT-LOW + 1.0, OPT-LOW + 2.0 .. 255.0
OC192-XFP.physicalthresholds.warning.1day.OPT-LOW	80 (%)	0.0, 1.0, 2.0 .. OPT-HIGH
OC192-XFP.pmthresholds.line.farend.15min.CV	85040 (B2 count)	0 - 8850600
OC192-XFP.pmthresholds.line.farend.15min.ES	87 (seconds)	0 - 900
OC192-XFP.pmthresholds.line.farend.15min.FC	10 (count)	0 - 72
OC192-XFP.pmthresholds.line.farend.15min.SES	1 (seconds)	0 - 900
OC192-XFP.pmthresholds.line.farend.15min.UAS	3 (seconds)	0 - 900
OC192-XFP.pmthresholds.line.farend.1day.CV	850400 (B2 count)	0 - 849657600
OC192-XFP.pmthresholds.line.farend.1day.ES	864 (seconds)	0 - 86400
OC192-XFP.pmthresholds.line.farend.1day.FC	40 (count)	0 - 6912
OC192-XFP.pmthresholds.line.farend.1day.SES	4 (seconds)	0 - 86400
OC192-XFP.pmthresholds.line.farend.1day.UAS	10 (seconds)	0 - 86400
OC192-XFP.pmthresholds.line.nearend.15min.CV	85040 (B2 count)	0 - 8850600
OC192-XFP.pmthresholds.line.nearend.15min.ES	87 (seconds)	0 - 900
OC192-XFP.pmthresholds.line.nearend.15min.FC	10 (count)	0 - 72
OC192-XFP.pmthresholds.line.nearend.15min.PSC	1 (count)	0 - 600
OC192-XFP.pmthresholds.line.nearend.15min.PSC-R	1 (count)	0 - 600
OC192-XFP.pmthresholds.line.nearend.15min.PSC-S	1 (count)	0 - 600
OC192-XFP.pmthresholds.line.nearend.15min.PSC-W	1 (count)	0 - 600
OC192-XFP.pmthresholds.line.nearend.15min.PSD	300 (seconds)	0 - 900
OC192-XFP.pmthresholds.line.nearend.15min.PSD-R	300 (seconds)	0 - 900
OC192-XFP.pmthresholds.line.nearend.15min.PSD-S	300 (seconds)	0 - 900
OC192-XFP.pmthresholds.line.nearend.15min.PSD-W	300 (seconds)	0 - 900
OC192-XFP.pmthresholds.line.nearend.15min.SES	1 (seconds)	0 - 900
OC192-XFP.pmthresholds.line.nearend.15min.UAS	3 (seconds)	0 - 900
OC192-XFP.pmthresholds.line.nearend.1day.CV	850400 (B2 count)	0 - 849657600
OC192-XFP.pmthresholds.line.nearend.1day.ES	864 (seconds)	0 - 86400
OC192-XFP.pmthresholds.line.nearend.1day.FC	40 (count)	0 - 6912
OC192-XFP.pmthresholds.line.nearend.1day.PSC	5 (count)	0 - 57600
OC192-XFP.pmthresholds.line.nearend.1day.PSC-R	5 (count)	0 - 57600

Table C-18 OC192-XFP Default Settings (continued)

Default Name	Default Value	Default Domain
OC192-XFP.pmthresholds.line.nearend.1day.PSC-S	5 (count)	0 - 57600
OC192-XFP.pmthresholds.line.nearend.1day.PSC-W	5 (count)	0 - 57600
OC192-XFP.pmthresholds.line.nearend.1day.PSD	600 (seconds)	0 - 86400
OC192-XFP.pmthresholds.line.nearend.1day.PSD-R	600 (seconds)	0 - 86400
OC192-XFP.pmthresholds.line.nearend.1day.PSD-S	600 (seconds)	0 - 86400
OC192-XFP.pmthresholds.line.nearend.1day.PSD-W	600 (seconds)	0 - 86400
OC192-XFP.pmthresholds.line.nearend.1day.SES	4 (seconds)	0 - 86400
OC192-XFP.pmthresholds.line.nearend.1day.UAS	10 (seconds)	0 - 86400
OC192-XFP.pmthresholds.section.nearend.15min.CV	10000 (B1 count)	0 - 7967700
OC192-XFP.pmthresholds.section.nearend.15min.ES	500 (seconds)	0 - 900
OC192-XFP.pmthresholds.section.nearend.15min.SEFS	500 (seconds)	0 - 900
OC192-XFP.pmthresholds.section.nearend.15min.SES	500 (seconds)	0 - 900
OC192-XFP.pmthresholds.section.nearend.1day.CV	100000 (B1 count)	0 - 764899200
OC192-XFP.pmthresholds.section.nearend.1day.ES	5000 (seconds)	0 - 86400
OC192-XFP.pmthresholds.section.nearend.1day.SEFS	5000 (seconds)	0 - 86400
OC192-XFP.pmthresholds.section.nearend.1day.SES	5000 (seconds)	0 - 86400
OC192-XFP.pmthresholds.sts1.farend.15min.CV	15 (B3 count)	0 - 2160000
OC192-XFP.pmthresholds.sts1.farend.15min.ES	12 (seconds)	0 - 900
OC192-XFP.pmthresholds.sts1.farend.15min.FC	10 (count)	0 - 72
OC192-XFP.pmthresholds.sts1.farend.15min.SES	3 (seconds)	0 - 900
OC192-XFP.pmthresholds.sts1.farend.15min.UAS	10 (seconds)	0 - 900
OC192-XFP.pmthresholds.sts1.farend.1day.CV	125 (B3 count)	0 - 207360000
OC192-XFP.pmthresholds.sts1.farend.1day.ES	100 (seconds)	0 - 86400
OC192-XFP.pmthresholds.sts1.farend.1day.FC	40 (count)	0 - 6912
OC192-XFP.pmthresholds.sts1.farend.1day.SES	7 (seconds)	0 - 86400
OC192-XFP.pmthresholds.sts1.farend.1day.UAS	10 (seconds)	0 - 86400
OC192-XFP.pmthresholds.sts1.nearend.15min.CV	15 (B3 count)	0 - 2160000
OC192-XFP.pmthresholds.sts1.nearend.15min.ES	12 (seconds)	0 - 900
OC192-XFP.pmthresholds.sts1.nearend.15min.FC	10 (count)	0 - 72
OC192-XFP.pmthresholds.sts1.nearend.15min.NPJC-PDET	60 (count)	0 - 7200000
OC192-XFP.pmthresholds.sts1.nearend.15min.NPJC-PGEN	60 (count)	0 - 7200000
OC192-XFP.pmthresholds.sts1.nearend.15min.PJCDIFF	60 (count)	0 - 1200
OC192-XFP.pmthresholds.sts1.nearend.15min.PJCS-PDET	100 (seconds)	0 - 7200000
OC192-XFP.pmthresholds.sts1.nearend.15min.PJCS-PGEN	100 (seconds)	0 - 7200000
OC192-XFP.pmthresholds.sts1.nearend.15min.PPJC-PDET	60 (count)	0 - 7200000
OC192-XFP.pmthresholds.sts1.nearend.15min.PPJC-PGEN	60 (count)	0 - 7200000

Table C-18 OC192-XFP Default Settings (continued)

Default Name	Default Value	Default Domain
OC192-XFP.pmthresholds.sts1.nearend.15min.SES	3 (seconds)	0 - 900
OC192-XFP.pmthresholds.sts1.nearend.15min.UAS	10 (seconds)	0 - 900
OC192-XFP.pmthresholds.sts1.nearend.1day.CV	125 (B3 count)	0 - 207360000
OC192-XFP.pmthresholds.sts1.nearend.1day.ES	100 (seconds)	0 - 86400
OC192-XFP.pmthresholds.sts1.nearend.1day.FC	40 (count)	0 - 6912
OC192-XFP.pmthresholds.sts1.nearend.1day.NPJC-PDET	5760 (count)	0 - 691200000
OC192-XFP.pmthresholds.sts1.nearend.1day.NPJC-PGEN	5760 (count)	0 - 691200000
OC192-XFP.pmthresholds.sts1.nearend.1day.PJCDIFF	5760 (count)	0 - 115200
OC192-XFP.pmthresholds.sts1.nearend.1day.PJCS-PDET	9600 (seconds)	0 - 691200000
OC192-XFP.pmthresholds.sts1.nearend.1day.PJCS-PGEN	9600 (seconds)	0 - 691200000
OC192-XFP.pmthresholds.sts1.nearend.1day.PPJC-PDET	5760 (count)	0 - 691200000
OC192-XFP.pmthresholds.sts1.nearend.1day.PPJC-PGEN	5760 (count)	0 - 691200000
OC192-XFP.pmthresholds.sts1.nearend.1day.SES	7 (seconds)	0 - 86400
OC192-XFP.pmthresholds.sts1.nearend.1day.UAS	10 (seconds)	0 - 86400
OC192-XFP.pmthresholds.sts12c-192c.farend.15min.CV	75 (B3 count)	0 - 2160000
OC192-XFP.pmthresholds.sts12c-192c.farend.15min.ES	60 (seconds)	0 - 900
OC192-XFP.pmthresholds.sts12c-192c.farend.15min.FC	10 (count)	0 - 72
OC192-XFP.pmthresholds.sts12c-192c.farend.15min.SES	3 (seconds)	0 - 900
OC192-XFP.pmthresholds.sts12c-192c.farend.15min.UAS	10 (seconds)	0 - 900
OC192-XFP.pmthresholds.sts12c-192c.farend.1day.CV	750 (B3 count)	0 - 207360000
OC192-XFP.pmthresholds.sts12c-192c.farend.1day.ES	600 (seconds)	0 - 86400
OC192-XFP.pmthresholds.sts12c-192c.farend.1day.FC	40 (count)	0 - 6912
OC192-XFP.pmthresholds.sts12c-192c.farend.1day.SES	7 (seconds)	0 - 86400
OC192-XFP.pmthresholds.sts12c-192c.farend.1day.UAS	10 (seconds)	0 - 86400
OC192-XFP.pmthresholds.sts12c-192c.nearend.15min.CV	75 (B3 count)	0 - 2160000
OC192-XFP.pmthresholds.sts12c-192c.nearend.15min.ES	60 (seconds)	0 - 900
OC192-XFP.pmthresholds.sts12c-192c.nearend.15min.FC	10 (count)	0 - 72
OC192-XFP.pmthresholds.sts12c-192c.nearend.15min.NPJC-PDET	60 (count)	0 - 7200000
OC192-XFP.pmthresholds.sts12c-192c.nearend.15min.NPJC-PGEN	60 (count)	0 - 7200000
OC192-XFP.pmthresholds.sts12c-192c.nearend.15min.PJCDIFF	60 (count)	0 - 1200
OC192-XFP.pmthresholds.sts12c-192c.nearend.15min.PJCS-PDET	100 (seconds)	0 - 7200000
OC192-XFP.pmthresholds.sts12c-192c.nearend.15min.PJCS-PGEN	100 (seconds)	0 - 7200000
OC192-XFP.pmthresholds.sts12c-192c.nearend.15min.PPJC-PDET	60 (count)	0 - 7200000
OC192-XFP.pmthresholds.sts12c-192c.nearend.15min.PPJC-PGEN	60 (count)	0 - 7200000
OC192-XFP.pmthresholds.sts12c-192c.nearend.15min.SES	3 (seconds)	0 - 900
OC192-XFP.pmthresholds.sts12c-192c.nearend.15min.UAS	10 (seconds)	0 - 900

Table C-18 OC192-XFP Default Settings (continued)

Default Name	Default Value	Default Domain
OC192-XFP.pmthresholds.sts12c-192c.nearend.1day.CV	750 (B3 count)	0 - 207360000
OC192-XFP.pmthresholds.sts12c-192c.nearend.1day.ES	600 (seconds)	0 - 86400
OC192-XFP.pmthresholds.sts12c-192c.nearend.1day.FC	40 (count)	0 - 6912
OC192-XFP.pmthresholds.sts12c-192c.nearend.1day.NPJC-PDET	5760 (count)	0 - 691200000
OC192-XFP.pmthresholds.sts12c-192c.nearend.1day.NPJC-PGEN	5760 (count)	0 - 691200000
OC192-XFP.pmthresholds.sts12c-192c.nearend.1day.PJCDIFF	5760 (count)	0 - 115200
OC192-XFP.pmthresholds.sts12c-192c.nearend.1day.PJCS-PDET	9600 (seconds)	0 - 691200000
OC192-XFP.pmthresholds.sts12c-192c.nearend.1day.PJCS-PGEN	9600 (seconds)	0 - 691200000
OC192-XFP.pmthresholds.sts12c-192c.nearend.1day.PPJC-PDET	5760 (count)	0 - 691200000
OC192-XFP.pmthresholds.sts12c-192c.nearend.1day.PPJC-PGEN	5760 (count)	0 - 691200000
OC192-XFP.pmthresholds.sts12c-192c.nearend.1day.SES	7 (seconds)	0 - 86400
OC192-XFP.pmthresholds.sts12c-192c.nearend.1day.UAS	10 (seconds)	0 - 86400
OC192-XFP.pmthresholds.sts3c-9c.farend.15min.CV	25 (B3 count)	0 - 2160000
OC192-XFP.pmthresholds.sts3c-9c.farend.15min.ES	20 (seconds)	0 - 900
OC192-XFP.pmthresholds.sts3c-9c.farend.15min.FC	10 (count)	0 - 72
OC192-XFP.pmthresholds.sts3c-9c.farend.15min.SES	3 (seconds)	0 - 900
OC192-XFP.pmthresholds.sts3c-9c.farend.15min.UAS	10 (seconds)	0 - 900
OC192-XFP.pmthresholds.sts3c-9c.farend.1day.CV	250 (B3 count)	0 - 207360000
OC192-XFP.pmthresholds.sts3c-9c.farend.1day.ES	200 (seconds)	0 - 86400
OC192-XFP.pmthresholds.sts3c-9c.farend.1day.FC	40 (count)	0 - 6912
OC192-XFP.pmthresholds.sts3c-9c.farend.1day.SES	7 (seconds)	0 - 86400
OC192-XFP.pmthresholds.sts3c-9c.farend.1day.UAS	10 (seconds)	0 - 86400
OC192-XFP.pmthresholds.sts3c-9c.nearend.15min.CV	25 (B3 count)	0 - 2160000
OC192-XFP.pmthresholds.sts3c-9c.nearend.15min.ES	20 (seconds)	0 - 900
OC192-XFP.pmthresholds.sts3c-9c.nearend.15min.FC	10 (count)	0 - 72
OC192-XFP.pmthresholds.sts3c-9c.nearend.15min.NPJC-PDET	60 (count)	0 - 7200000
OC192-XFP.pmthresholds.sts3c-9c.nearend.15min.NPJC-PGEN	60 (count)	0 - 7200000
OC192-XFP.pmthresholds.sts3c-9c.nearend.15min.PJCDIFF	60 (count)	0 - 1200
OC192-XFP.pmthresholds.sts3c-9c.nearend.15min.PJCS-PDET	100 (seconds)	0 - 7200000
OC192-XFP.pmthresholds.sts3c-9c.nearend.15min.PJCS-PGEN	100 (seconds)	0 - 7200000
OC192-XFP.pmthresholds.sts3c-9c.nearend.15min.PPJC-PDET	60 (count)	0 - 7200000
OC192-XFP.pmthresholds.sts3c-9c.nearend.15min.PPJC-PGEN	60 (count)	0 - 7200000
OC192-XFP.pmthresholds.sts3c-9c.nearend.15min.SES	3 (seconds)	0 - 900
OC192-XFP.pmthresholds.sts3c-9c.nearend.15min.UAS	10 (seconds)	0 - 900
OC192-XFP.pmthresholds.sts3c-9c.nearend.1day.CV	250 (B3 count)	0 - 207360000
OC192-XFP.pmthresholds.sts3c-9c.nearend.1day.ES	200 (seconds)	0 - 86400

Table C-18 OC192-XFP Default Settings (continued)

Default Name	Default Value	Default Domain
OC192-XFP.pmthresholds.sts3c-9c.nearend.1day.FC	40 (count)	0 - 6912
OC192-XFP.pmthresholds.sts3c-9c.nearend.1day.NPJC-PDET	5760 (count)	0 - 691200000
OC192-XFP.pmthresholds.sts3c-9c.nearend.1day.NPJC-PGEN	5760 (count)	0 - 691200000
OC192-XFP.pmthresholds.sts3c-9c.nearend.1day.PJCDIFF	5760 (count)	0 - 115200
OC192-XFP.pmthresholds.sts3c-9c.nearend.1day.PJCS-PDET	9600 (seconds)	0 - 691200000
OC192-XFP.pmthresholds.sts3c-9c.nearend.1day.PJCS-PGEN	9600 (seconds)	0 - 691200000
OC192-XFP.pmthresholds.sts3c-9c.nearend.1day.PPJC-PDET	5760 (count)	0 - 691200000
OC192-XFP.pmthresholds.sts3c-9c.nearend.1day.PPJC-PGEN	5760 (count)	0 - 691200000
OC192-XFP.pmthresholds.sts3c-9c.nearend.1day.SES	7 (seconds)	0 - 86400
OC192-XFP.pmthresholds.sts3c-9c.nearend.1day.UAS	10 (seconds)	0 - 86400

C.2.3.19 MRC-12 Card Default Settings

Table C-19 lists the MRC-12 card default settings.

Table C-19 MRC-12 Card Default Settings

Default Name	Default Value	Default Domain
MRC-12.config.oc12.line.AINSSoakTime	08:00 (hours:mins)	00:00, 00:15, 00:30 .. 48:00
MRC-12.config.oc12.line.AlsMode	Disabled	Disabled, Auto Restart, Manual Restart, Manual Restart for Test
MRC-12.config.oc12.line.AlsRecoveryPulseDuration	2.0 (seconds)	2.0, 2.1, 2.2 .. 100.0 when AlsMode Disabled, Auto Restart, Manual Restart; 80.0, 80.1, 80.2 .. 100.0 when AlsMode Manual Restart for Test
MRC-12.config.oc12.line.AlsRecoveryPulseInterval	100 (seconds)	60 - 300
MRC-12.config.oc12.line.PJStsMon#	0 (STS #)	0 - 12
MRC-12.config.oc12.line.SDBER	1E-7	1E-5, 1E-6, 1E-7, 1E-8, 1E-9
MRC-12.config.oc12.line.Send<FF>DoNotUse	FALSE	FALSE when SendDoNotUse TRUE; FALSE, TRUE when SendDoNotUse FALSE
MRC-12.config.oc12.line.SendDoNotUse	FALSE	FALSE, TRUE
MRC-12.config.oc12.line.SFBER	1E-4	1E-3, 1E-4, 1E-5
MRC-12.config.oc12.line.State	IS,AINS	IS, OOS,DSBLD, OOS,MT, IS,AINS
MRC-12.config.oc12.line.SyncMsgIn	TRUE	FALSE, TRUE
MRC-12.config.oc12.sts.IPPMEnabled	FALSE	TRUE, FALSE
MRC-12.config.oc3.line.AINSSoakTime	08:00 (hours:mins)	00:00, 00:15, 00:30 .. 48:00

Table C-19 MRC-12 Card Default Settings (continued)

Default Name	Default Value	Default Domain
MRC-12.config.oc3.line.AlsMode	Disabled	Disabled, Auto Restart, Manual Restart, Manual Restart for Test
MRC-12.config.oc3.line.AlsRecoveryPulseDuration	2.0 (seconds)	2.0, 2.1, 2.2 .. 100.0 when AlsMode Disabled, Auto Restart, Manual Restart; 80.0, 80.1, 80.2 .. 100.0 when AlsMode Manual Restart for Test
MRC-12.config.oc3.line.AlsRecoveryPulseInterval	100 (seconds)	60 - 300
MRC-12.config.oc3.line.PJStsMon#	0 (STS #)	0 - 3
MRC-12.config.oc3.line.SDBER	1E-7	1E-5, 1E-6, 1E-7, 1E-8, 1E-9
MRC-12.config.oc3.line.Send<FF>DoNotUse	FALSE	FALSE when SendDoNotUse TRUE; FALSE, TRUE when SendDoNotUse FALSE
MRC-12.config.oc3.line.SendDoNotUse	FALSE	FALSE, TRUE
MRC-12.config.oc3.line.SFBER	1E-4	1E-3, 1E-4, 1E-5
MRC-12.config.oc3.line.State	IS,AINS	IS, OOS,DSBLD, OOS,MT, IS,AINS
MRC-12.config.oc3.line.SyncMsgIn	TRUE	FALSE, TRUE
MRC-12.config.oc3.sts.IPPMEnabled	FALSE	TRUE, FALSE
MRC-12.config.oc48.line.AINSSoakTime	08:00 (hours:mins)	00:00, 00:15, 00:30 .. 48:00
MRC-12.config.oc48.line.AlsMode	Disabled	Disabled, Auto Restart, Manual Restart, Manual Restart for Test
MRC-12.config.oc48.line.AlsRecoveryPulseDuration	2.0 (seconds)	2.0, 2.1, 2.2 .. 100.0 when AlsMode Disabled, Auto Restart, Manual Restart; 80.0, 80.1, 80.2 .. 100.0 when AlsMode Manual Restart for Test
MRC-12.config.oc48.line.AlsRecoveryPulseInterval	100 (seconds)	60 - 300
MRC-12.config.oc48.line.PJStsMon#	0 (STS #)	0 - 48
MRC-12.config.oc48.line.SDBER	1E-7	1E-5, 1E-6, 1E-7, 1E-8, 1E-9
MRC-12.config.oc48.line.Send<FF>DoNotUse	FALSE	FALSE when SendDoNotUse TRUE; FALSE, TRUE when SendDoNotUse FALSE
MRC-12.config.oc48.line.SendDoNotUse	FALSE	FALSE, TRUE
MRC-12.config.oc48.line.SFBER	1E-4	1E-3, 1E-4, 1E-5
MRC-12.config.oc48.line.State	IS,AINS	IS, OOS,DSBLD, OOS,MT, IS,AINS
MRC-12.config.oc48.line.SyncMsgIn	TRUE	FALSE, TRUE
MRC-12.config.oc48.sts.IPPMEnabled	FALSE	TRUE, FALSE

Table C-19 MRC-12 Card Default Settings (continued)

Default Name	Default Value	Default Domain
MRC-12.physicalthresholds.oc12.alarm.LBC-HIGH	200 (%)	LBC-LOW, LBC-LOW + 1.0, LBC-LOW + 2.0 .. 255.0
MRC-12.physicalthresholds.oc12.alarm.LBC-LOW	20 (%)	0.0, 1.0, 2.0 .. LBC-HIGH
MRC-12.physicalthresholds.oc12.alarm.OPR-HIGH	200 (%)	OPR-LOW, OPR-LOW + 1.0, OPR-LOW + 2.0 .. 255.0
MRC-12.physicalthresholds.oc12.alarm.OPR-LOW	50 (%)	0.0, 1.0, 2.0 .. OPR-HIGH
MRC-12.physicalthresholds.oc12.alarm.OPT-HIGH	120 (%)	OPT-LOW, OPT-LOW + 1.0, OPT-LOW + 2.0 .. 255.0
MRC-12.physicalthresholds.oc12.alarm.OPT-LOW	80 (%)	0.0, 1.0, 2.0 .. OPT-HIGH
MRC-12.physicalthresholds.oc12.warning.15min.LBC-HIGH	200 (%)	LBC-LOW, LBC-LOW + 1.0, LBC-LOW + 2.0 .. 255.0
MRC-12.physicalthresholds.oc12.warning.15min.LBC-LOW	20 (%)	0.0, 1.0, 2.0 .. LBC-HIGH
MRC-12.physicalthresholds.oc12.warning.15min.OPR-HIGH	200 (%)	OPR-LOW, OPR-LOW + 1.0, OPR-LOW + 2.0 .. 255.0
MRC-12.physicalthresholds.oc12.warning.15min.OPR-LOW	50 (%)	0.0, 1.0, 2.0 .. OPR-HIGH
MRC-12.physicalthresholds.oc12.warning.15min.OPT-HIGH	120 (%)	OPT-LOW, OPT-LOW + 1.0, OPT-LOW + 2.0 .. 255.0
MRC-12.physicalthresholds.oc12.warning.15min.OPT-LOW	80 (%)	0.0, 1.0, 2.0 .. OPT-HIGH
MRC-12.physicalthresholds.oc12.warning.1day.LBC-HIGH	200 (%)	LBC-LOW, LBC-LOW + 1.0, LBC-LOW + 2.0 .. 255.0
MRC-12.physicalthresholds.oc12.warning.1day.LBC-LOW	20 (%)	0.0, 1.0, 2.0 .. LBC-HIGH
MRC-12.physicalthresholds.oc12.warning.1day.OPR-HIGH	200 (%)	OPR-LOW, OPR-LOW + 1.0, OPR-LOW + 2.0 .. 255.0
MRC-12.physicalthresholds.oc12.warning.1day.OPR-LOW	50 (%)	0.0, 1.0, 2.0 .. OPR-HIGH
MRC-12.physicalthresholds.oc12.warning.1day.OPT-HIGH	120 (%)	OPT-LOW, OPT-LOW + 1.0, OPT-LOW + 2.0 .. 255.0
MRC-12.physicalthresholds.oc12.warning.1day.OPT-LOW	80 (%)	0.0, 1.0, 2.0 .. OPT-HIGH
MRC-12.physicalthresholds.oc3.alarm.LBC-HIGH	200 (%)	LBC-LOW, LBC-LOW + 1.0, LBC-LOW + 2.0 .. 255.0
MRC-12.physicalthresholds.oc3.alarm.LBC-LOW	20 (%)	0.0, 1.0, 2.0 .. LBC-HIGH
MRC-12.physicalthresholds.oc3.alarm.OPR-HIGH	200 (%)	OPR-LOW, OPR-LOW + 1.0, OPR-LOW + 2.0 .. 255.0
MRC-12.physicalthresholds.oc3.alarm.OPR-LOW	50 (%)	0.0, 1.0, 2.0 .. OPR-HIGH
MRC-12.physicalthresholds.oc3.alarm.OPT-HIGH	120 (%)	OPT-LOW, OPT-LOW + 1.0, OPT-LOW + 2.0 .. 255.0
MRC-12.physicalthresholds.oc3.alarm.OPT-LOW	80 (%)	0.0, 1.0, 2.0 .. OPT-HIGH
MRC-12.physicalthresholds.oc3.warning.15min.LBC-HIGH	200 (%)	LBC-LOW, LBC-LOW + 1.0, LBC-LOW + 2.0 .. 255.0
MRC-12.physicalthresholds.oc3.warning.15min.LBC-LOW	20 (%)	0.0, 1.0, 2.0 .. LBC-HIGH

Table C-19 MRC-12 Card Default Settings (continued)

Default Name	Default Value	Default Domain
MRC-12.physicalthresholds.oc3.warning.15min.OPR-HIGH	200 (%)	OPR-LOW, OPR-LOW + 1.0, OPR-LOW + 2.0 .. 255.0
MRC-12.physicalthresholds.oc3.warning.15min.OPR-LOW	50 (%)	0.0, 1.0, 2.0 .. OPR-HIGH
MRC-12.physicalthresholds.oc3.warning.15min.OPT-HIGH	120 (%)	OPT-LOW, OPT-LOW + 1.0, OPT-LOW + 2.0 .. 255.0
MRC-12.physicalthresholds.oc3.warning.15min.OPT-LOW	80 (%)	0.0, 1.0, 2.0 .. OPT-HIGH
MRC-12.physicalthresholds.oc3.warning.1day.LBC-HIGH	200 (%)	LBC-LOW, LBC-LOW + 1.0, LBC-LOW + 2.0 .. 255.0
MRC-12.physicalthresholds.oc3.warning.1day.LBC-LOW	20 (%)	0.0, 1.0, 2.0 .. LBC-HIGH
MRC-12.physicalthresholds.oc3.warning.1day.OPR-HIGH	200 (%)	OPR-LOW, OPR-LOW + 1.0, OPR-LOW + 2.0 .. 255.0
MRC-12.physicalthresholds.oc3.warning.1day.OPR-LOW	50 (%)	0.0, 1.0, 2.0 .. OPR-HIGH
MRC-12.physicalthresholds.oc3.warning.1day.OPT-HIGH	120 (%)	OPT-LOW, OPT-LOW + 1.0, OPT-LOW + 2.0 .. 255.0
MRC-12.physicalthresholds.oc3.warning.1day.OPT-LOW	80 (%)	0.0, 1.0, 2.0 .. OPT-HIGH
MRC-12.physicalthresholds.oc48.alarm.LBC-HIGH	200 (%)	LBC-LOW, LBC-LOW + 1.0, LBC-LOW + 2.0 .. 255.0
MRC-12.physicalthresholds.oc48.alarm.LBC-LOW	20 (%)	0.0, 1.0, 2.0 .. LBC-HIGH
MRC-12.physicalthresholds.oc48.alarm.OPR-HIGH	200 (%)	OPR-LOW, OPR-LOW + 1.0, OPR-LOW + 2.0 .. 255.0
MRC-12.physicalthresholds.oc48.alarm.OPR-LOW	50 (%)	0.0, 1.0, 2.0 .. OPR-HIGH
MRC-12.physicalthresholds.oc48.alarm.OPT-HIGH	120 (%)	OPT-LOW, OPT-LOW + 1.0, OPT-LOW + 2.0 .. 255.0
MRC-12.physicalthresholds.oc48.alarm.OPT-LOW	80 (%)	0.0, 1.0, 2.0 .. OPT-HIGH
MRC-12.physicalthresholds.oc48.warning.15min.LBC-HIGH	200 (%)	LBC-LOW, LBC-LOW + 1.0, LBC-LOW + 2.0 .. 255.0
MRC-12.physicalthresholds.oc48.warning.15min.LBC-LOW	20 (%)	0.0, 1.0, 2.0 .. LBC-HIGH
MRC-12.physicalthresholds.oc48.warning.15min.OPR-HIGH	200 (%)	OPR-LOW, OPR-LOW + 1.0, OPR-LOW + 2.0 .. 255.0
MRC-12.physicalthresholds.oc48.warning.15min.OPR-LOW	50 (%)	0.0, 1.0, 2.0 .. OPR-HIGH
MRC-12.physicalthresholds.oc48.warning.15min.OPT-HIGH	120 (%)	OPT-LOW, OPT-LOW + 1.0, OPT-LOW + 2.0 .. 255.0
MRC-12.physicalthresholds.oc48.warning.15min.OPT-LOW	80 (%)	0.0, 1.0, 2.0 .. OPT-HIGH
MRC-12.physicalthresholds.oc48.warning.1day.LBC-HIGH	200 (%)	LBC-LOW, LBC-LOW + 1.0, LBC-LOW + 2.0 .. 255.0
MRC-12.physicalthresholds.oc48.warning.1day.LBC-LOW	20 (%)	0.0, 1.0, 2.0 .. LBC-HIGH
MRC-12.physicalthresholds.oc48.warning.1day.OPR-HIGH	200 (%)	OPR-LOW, OPR-LOW + 1.0, OPR-LOW + 2.0 .. 255.0
MRC-12.physicalthresholds.oc48.warning.1day.OPR-LOW	50 (%)	0.0, 1.0, 2.0 .. OPR-HIGH

Table C-19 MRC-12 Card Default Settings (continued)

Default Name	Default Value	Default Domain
MRC-12.physicalthresholds.oc48.warning.1day.OPT-HIGH	120 (%)	OPT-LOW, OPT-LOW + 1.0, OPT-LOW + 2.0 .. 255.0
MRC-12.physicalthresholds.oc48.warning.1day.OPT-LOW	80 (%)	0.0, 1.0, 2.0 .. OPT-HIGH
MRC-12.pmthresholds.oc12.line.farend.15min.CV	5315 (B2 count)	0 - 552600
MRC-12.pmthresholds.oc12.line.farend.15min.ES	87 (seconds)	0 - 900
MRC-12.pmthresholds.oc12.line.farend.15min.FC	10 (count)	0 - 72
MRC-12.pmthresholds.oc12.line.farend.15min.SES	1 (seconds)	0 - 900
MRC-12.pmthresholds.oc12.line.farend.15min.UAS	3 (seconds)	0 - 900
MRC-12.pmthresholds.oc12.line.farend.1day.CV	53150 (B2 count)	0 - 53049600
MRC-12.pmthresholds.oc12.line.farend.1day.ES	864 (seconds)	0 - 86400
MRC-12.pmthresholds.oc12.line.farend.1day.FC	40 (count)	0 - 6912
MRC-12.pmthresholds.oc12.line.farend.1day.SES	4 (seconds)	0 - 86400
MRC-12.pmthresholds.oc12.line.farend.1day.UAS	10 (seconds)	0 - 86400
MRC-12.pmthresholds.oc12.line.nearend.15min.CV	5315 (B2 count)	0 - 552600
MRC-12.pmthresholds.oc12.line.nearend.15min.ES	87 (seconds)	0 - 900
MRC-12.pmthresholds.oc12.line.nearend.15min.FC	10 (count)	0 - 72
MRC-12.pmthresholds.oc12.line.nearend.15min.PSC	1 (count)	0 - 600
MRC-12.pmthresholds.oc12.line.nearend.15min.PSC-W	1 (count)	0 - 600
MRC-12.pmthresholds.oc12.line.nearend.15min.PSD	300 (seconds)	0 - 900
MRC-12.pmthresholds.oc12.line.nearend.15min.PSD-W	300 (seconds)	0 - 900
MRC-12.pmthresholds.oc12.line.nearend.15min.SES	1 (seconds)	0 - 900
MRC-12.pmthresholds.oc12.line.nearend.15min.UAS	3 (seconds)	0 - 900
MRC-12.pmthresholds.oc12.line.nearend.1day.CV	53150 (B2 count)	0 - 53049600
MRC-12.pmthresholds.oc12.line.nearend.1day.ES	864 (seconds)	0 - 86400
MRC-12.pmthresholds.oc12.line.nearend.1day.FC	40 (count)	0 - 6912
MRC-12.pmthresholds.oc12.line.nearend.1day.PSC	5 (count)	0 - 57600
MRC-12.pmthresholds.oc12.line.nearend.1day.PSC-W	5 (count)	0 - 57600
MRC-12.pmthresholds.oc12.line.nearend.1day.PSD	600 (seconds)	0 - 86400
MRC-12.pmthresholds.oc12.line.nearend.1day.PSD-W	600 (seconds)	0 - 86400
MRC-12.pmthresholds.oc12.line.nearend.1day.SES	4 (seconds)	0 - 86400
MRC-12.pmthresholds.oc12.line.nearend.1day.UAS	10 (seconds)	0 - 86400
MRC-12.pmthresholds.oc12.section.nearend.15min.CV	10000 (B1 count)	0 - 553500
MRC-12.pmthresholds.oc12.section.nearend.15min.ES	500 (seconds)	0 - 900
MRC-12.pmthresholds.oc12.section.nearend.15min.SEFS	500 (seconds)	0 - 900
MRC-12.pmthresholds.oc12.section.nearend.15min.SES	500 (seconds)	0 - 900
MRC-12.pmthresholds.oc12.section.nearend.1day.CV	100000 (B1 count)	0 - 53136000

Table C-19 MRC-12 Card Default Settings (continued)

Default Name	Default Value	Default Domain
MRC-12.pmthresholds.oc12.section.nearend.1day.ES	5000 (seconds)	0 - 86400
MRC-12.pmthresholds.oc12.section.nearend.1day.SEFS	5000 (seconds)	0 - 86400
MRC-12.pmthresholds.oc12.section.nearend.1day.SES	5000 (seconds)	0 - 86400
MRC-12.pmthresholds.oc12.sts1.farend.15min.CV	15 (B3 count)	0 - 2160000
MRC-12.pmthresholds.oc12.sts1.farend.15min.ES	12 (seconds)	0 - 900
MRC-12.pmthresholds.oc12.sts1.farend.15min.FC	10 (count)	0 - 72
MRC-12.pmthresholds.oc12.sts1.farend.15min.SES	3 (seconds)	0 - 900
MRC-12.pmthresholds.oc12.sts1.farend.15min.UAS	10 (seconds)	0 - 900
MRC-12.pmthresholds.oc12.sts1.farend.1day.CV	125 (B3 count)	0 - 207360000
MRC-12.pmthresholds.oc12.sts1.farend.1day.ES	100 (seconds)	0 - 86400
MRC-12.pmthresholds.oc12.sts1.farend.1day.FC	40 (count)	0 - 6912
MRC-12.pmthresholds.oc12.sts1.farend.1day.SES	7 (seconds)	0 - 86400
MRC-12.pmthresholds.oc12.sts1.farend.1day.UAS	10 (seconds)	0 - 86400
MRC-12.pmthresholds.oc12.sts1.nearend.15min.CV	15 (B3 count)	0 - 2160000
MRC-12.pmthresholds.oc12.sts1.nearend.15min.ES	12 (seconds)	0 - 900
MRC-12.pmthresholds.oc12.sts1.nearend.15min.FC	10 (count)	0 - 72
MRC-12.pmthresholds.oc12.sts1.nearend.15min.NPJC-PDET	60 (count)	0 - 7200000
MRC-12.pmthresholds.oc12.sts1.nearend.15min.NPJC-PGEN	60 (count)	0 - 7200000
MRC-12.pmthresholds.oc12.sts1.nearend.15min.PJCDIFF	60 (count)	0 - 1200
MRC-12.pmthresholds.oc12.sts1.nearend.15min.PJCS-PDET	100 (seconds)	0 - 7200000
MRC-12.pmthresholds.oc12.sts1.nearend.15min.PJCS-PGEN	100 (seconds)	0 - 7200000
MRC-12.pmthresholds.oc12.sts1.nearend.15min.PPJC-PDET	60 (count)	0 - 7200000
MRC-12.pmthresholds.oc12.sts1.nearend.15min.PPJC-PGEN	60 (count)	0 - 7200000
MRC-12.pmthresholds.oc12.sts1.nearend.15min.SES	3 (seconds)	0 - 900
MRC-12.pmthresholds.oc12.sts1.nearend.15min.UAS	10 (seconds)	0 - 900
MRC-12.pmthresholds.oc12.sts1.nearend.1day.CV	125 (B3 count)	0 - 207360000
MRC-12.pmthresholds.oc12.sts1.nearend.1day.ES	100 (seconds)	0 - 86400
MRC-12.pmthresholds.oc12.sts1.nearend.1day.FC	40 (count)	0 - 6912
MRC-12.pmthresholds.oc12.sts1.nearend.1day.NPJC-PDET	5760 (count)	0 - 691200000
MRC-12.pmthresholds.oc12.sts1.nearend.1day.NPJC-PGEN	5760 (count)	0 - 691200000
MRC-12.pmthresholds.oc12.sts1.nearend.1day.PJCDIFF	5760 (count)	0 - 115200
MRC-12.pmthresholds.oc12.sts1.nearend.1day.PJCS-PDET	9600 (seconds)	0 - 691200000
MRC-12.pmthresholds.oc12.sts1.nearend.1day.PJCS-PGEN	9600 (seconds)	0 - 691200000
MRC-12.pmthresholds.oc12.sts1.nearend.1day.PPJC-PDET	5760 (count)	0 - 691200000
MRC-12.pmthresholds.oc12.sts1.nearend.1day.PPJC-PGEN	5760 (count)	0 - 691200000
MRC-12.pmthresholds.oc12.sts1.nearend.1day.SES	7 (seconds)	0 - 86400

Table C-19 MRC-12 Card Default Settings (continued)

Default Name	Default Value	Default Domain
MRC-12.pmthresholds.oc12.sts1.nearend.1day.UAS	10 (seconds)	0 - 86400
MRC-12.pmthresholds.oc12.sts12c.farend.15min.CV	75 (B3 count)	0 - 2160000
MRC-12.pmthresholds.oc12.sts12c.farend.15min.ES	60 (seconds)	0 - 900
MRC-12.pmthresholds.oc12.sts12c.farend.15min.FC	10 (count)	0 - 72
MRC-12.pmthresholds.oc12.sts12c.farend.15min.SES	3 (seconds)	0 - 900
MRC-12.pmthresholds.oc12.sts12c.farend.15min.UAS	10 (seconds)	0 - 900
MRC-12.pmthresholds.oc12.sts12c.farend.1day.CV	750 (B3 count)	0 - 207360000
MRC-12.pmthresholds.oc12.sts12c.farend.1day.ES	600 (seconds)	0 - 86400
MRC-12.pmthresholds.oc12.sts12c.farend.1day.FC	40 (count)	0 - 6912
MRC-12.pmthresholds.oc12.sts12c.farend.1day.SES	7 (seconds)	0 - 86400
MRC-12.pmthresholds.oc12.sts12c.farend.1day.UAS	10 (seconds)	0 - 86400
MRC-12.pmthresholds.oc12.sts12c.nearend.15min.CV	75 (B3 count)	0 - 2160000
MRC-12.pmthresholds.oc12.sts12c.nearend.15min.ES	60 (seconds)	0 - 900
MRC-12.pmthresholds.oc12.sts12c.nearend.15min.FC	10 (count)	0 - 72
MRC-12.pmthresholds.oc12.sts12c.nearend.15min.NPJC-PDET	60 (count)	0 - 7200000
MRC-12.pmthresholds.oc12.sts12c.nearend.15min.NPJC-PGEN	60 (count)	0 - 7200000
MRC-12.pmthresholds.oc12.sts12c.nearend.15min.PJCDIFF	60 (count)	0 - 1200
MRC-12.pmthresholds.oc12.sts12c.nearend.15min.PJCS-PDET	100 (seconds)	0 - 7200000
MRC-12.pmthresholds.oc12.sts12c.nearend.15min.PJCS-PGEN	100 (seconds)	0 - 7200000
MRC-12.pmthresholds.oc12.sts12c.nearend.15min.PPJC-PDET	60 (count)	0 - 7200000
MRC-12.pmthresholds.oc12.sts12c.nearend.15min.PPJC-PGEN	60 (count)	0 - 7200000
MRC-12.pmthresholds.oc12.sts12c.nearend.15min.SES	3 (seconds)	0 - 900
MRC-12.pmthresholds.oc12.sts12c.nearend.15min.UAS	10 (seconds)	0 - 900
MRC-12.pmthresholds.oc12.sts12c.nearend.1day.CV	750 (B3 count)	0 - 207360000
MRC-12.pmthresholds.oc12.sts12c.nearend.1day.ES	600 (seconds)	0 - 86400
MRC-12.pmthresholds.oc12.sts12c.nearend.1day.FC	40 (count)	0 - 6912
MRC-12.pmthresholds.oc12.sts12c.nearend.1day.NPJC-PDET	5760 (count)	0 - 691200000
MRC-12.pmthresholds.oc12.sts12c.nearend.1day.NPJC-PGEN	5760 (count)	0 - 691200000
MRC-12.pmthresholds.oc12.sts12c.nearend.1day.PJCDIFF	5760 (count)	0 - 115200
MRC-12.pmthresholds.oc12.sts12c.nearend.1day.PJCS-PDET	9600 (seconds)	0 - 691200000
MRC-12.pmthresholds.oc12.sts12c.nearend.1day.PJCS-PGEN	9600 (seconds)	0 - 691200000
MRC-12.pmthresholds.oc12.sts12c.nearend.1day.PPJC-PDET	5760 (count)	0 - 691200000
MRC-12.pmthresholds.oc12.sts12c.nearend.1day.PPJC-PGEN	5760 (count)	0 - 691200000
MRC-12.pmthresholds.oc12.sts12c.nearend.1day.SES	7 (seconds)	0 - 86400
MRC-12.pmthresholds.oc12.sts12c.nearend.1day.UAS	10 (seconds)	0 - 86400
MRC-12.pmthresholds.oc12.sts3c-9c.farend.15min.CV	25 (B3 count)	0 - 2160000

Table C-19 MRC-12 Card Default Settings (continued)

Default Name	Default Value	Default Domain
MRC-12.pmthresholds.oc12.sts3c-9c.farend.15min.ES	20 (seconds)	0 - 900
MRC-12.pmthresholds.oc12.sts3c-9c.farend.15min.FC	10 (count)	0 - 72
MRC-12.pmthresholds.oc12.sts3c-9c.farend.15min.SES	3 (seconds)	0 - 900
MRC-12.pmthresholds.oc12.sts3c-9c.farend.15min.UAS	10 (seconds)	0 - 900
MRC-12.pmthresholds.oc12.sts3c-9c.farend.1day.CV	250 (B3 count)	0 - 207360000
MRC-12.pmthresholds.oc12.sts3c-9c.farend.1day.ES	200 (seconds)	0 - 86400
MRC-12.pmthresholds.oc12.sts3c-9c.farend.1day.FC	40 (count)	0 - 6912
MRC-12.pmthresholds.oc12.sts3c-9c.farend.1day.SES	7 (seconds)	0 - 86400
MRC-12.pmthresholds.oc12.sts3c-9c.farend.1day.UAS	10 (seconds)	0 - 86400
MRC-12.pmthresholds.oc12.sts3c-9c.nearend.15min.CV	25 (B3 count)	0 - 2160000
MRC-12.pmthresholds.oc12.sts3c-9c.nearend.15min.ES	20 (seconds)	0 - 900
MRC-12.pmthresholds.oc12.sts3c-9c.nearend.15min.FC	10 (count)	0 - 72
MRC-12.pmthresholds.oc12.sts3c-9c.nearend.15min.NPJC-PDET	60 (count)	0 - 7200000
MRC-12.pmthresholds.oc12.sts3c-9c.nearend.15min.NPJC-PGEN	60 (count)	0 - 7200000
MRC-12.pmthresholds.oc12.sts3c-9c.nearend.15min.PJCDIFF	60 (count)	0 - 1200
MRC-12.pmthresholds.oc12.sts3c-9c.nearend.15min.PJCS-PDET	100 (seconds)	0 - 7200000
MRC-12.pmthresholds.oc12.sts3c-9c.nearend.15min.PJCS-PGEN	100 (seconds)	0 - 7200000
MRC-12.pmthresholds.oc12.sts3c-9c.nearend.15min.PPJC-PDET	60 (count)	0 - 7200000
MRC-12.pmthresholds.oc12.sts3c-9c.nearend.15min.PPJC-PGEN	60 (count)	0 - 7200000
MRC-12.pmthresholds.oc12.sts3c-9c.nearend.15min.SES	3 (seconds)	0 - 900
MRC-12.pmthresholds.oc12.sts3c-9c.nearend.15min.UAS	10 (seconds)	0 - 900
MRC-12.pmthresholds.oc12.sts3c-9c.nearend.1day.CV	250 (B3 count)	0 - 207360000
MRC-12.pmthresholds.oc12.sts3c-9c.nearend.1day.ES	200 (seconds)	0 - 86400
MRC-12.pmthresholds.oc12.sts3c-9c.nearend.1day.FC	40 (count)	0 - 6912
MRC-12.pmthresholds.oc12.sts3c-9c.nearend.1day.NPJC-PDET	5760 (count)	0 - 691200000
MRC-12.pmthresholds.oc12.sts3c-9c.nearend.1day.NPJC-PGEN	5760 (count)	0 - 691200000
MRC-12.pmthresholds.oc12.sts3c-9c.nearend.1day.PJCDIFF	5760 (count)	0 - 115200
MRC-12.pmthresholds.oc12.sts3c-9c.nearend.1day.PJCS-PDET	9600 (seconds)	0 - 691200000
MRC-12.pmthresholds.oc12.sts3c-9c.nearend.1day.PJCS-PGEN	9600 (seconds)	0 - 691200000
MRC-12.pmthresholds.oc12.sts3c-9c.nearend.1day.PPJC-PDET	5760 (count)	0 - 691200000
MRC-12.pmthresholds.oc12.sts3c-9c.nearend.1day.PPJC-PGEN	5760 (count)	0 - 691200000
MRC-12.pmthresholds.oc12.sts3c-9c.nearend.1day.SES	7 (seconds)	0 - 86400
MRC-12.pmthresholds.oc12.sts3c-9c.nearend.1day.UAS	10 (seconds)	0 - 86400
MRC-12.pmthresholds.oc3.line.farend.15min.CV	1312 (B2 count)	0 - 137700
MRC-12.pmthresholds.oc3.line.farend.15min.ES	87 (seconds)	0 - 900
MRC-12.pmthresholds.oc3.line.farend.15min.FC	10 (count)	0 - 72

Table C-19 MRC-12 Card Default Settings (continued)

Default Name	Default Value	Default Domain
MRC-12.pmthresholds.oc3.line.farend.15min.SES	1 (seconds)	0 - 900
MRC-12.pmthresholds.oc3.line.farend.15min.UAS	3 (seconds)	0 - 900
MRC-12.pmthresholds.oc3.line.farend.1day.CV	13120 (B2 count)	0 - 13219200
MRC-12.pmthresholds.oc3.line.farend.1day.ES	864 (seconds)	0 - 86400
MRC-12.pmthresholds.oc3.line.farend.1day.FC	40 (count)	0 - 6912
MRC-12.pmthresholds.oc3.line.farend.1day.SES	4 (seconds)	0 - 86400
MRC-12.pmthresholds.oc3.line.farend.1day.UAS	10 (seconds)	0 - 86400
MRC-12.pmthresholds.oc3.line.nearend.15min.CV	1312 (B2 count)	0 - 137700
MRC-12.pmthresholds.oc3.line.nearend.15min.ES	87 (seconds)	0 - 900
MRC-12.pmthresholds.oc3.line.nearend.15min.FC	10 (count)	0 - 72
MRC-12.pmthresholds.oc3.line.nearend.15min.PSC	1 (count)	0 - 600
MRC-12.pmthresholds.oc3.line.nearend.15min.PSD	300 (seconds)	0 - 900
MRC-12.pmthresholds.oc3.line.nearend.15min.SES	1 (seconds)	0 - 900
MRC-12.pmthresholds.oc3.line.nearend.15min.UAS	3 (seconds)	0 - 900
MRC-12.pmthresholds.oc3.line.nearend.1day.CV	13120 (B2 count)	0 - 13219200
MRC-12.pmthresholds.oc3.line.nearend.1day.ES	864 (seconds)	0 - 86400
MRC-12.pmthresholds.oc3.line.nearend.1day.FC	40 (count)	0 - 6912
MRC-12.pmthresholds.oc3.line.nearend.1day.PSC	5 (count)	0 - 57600
MRC-12.pmthresholds.oc3.line.nearend.1day.PSD	600 (seconds)	0 - 86400
MRC-12.pmthresholds.oc3.line.nearend.1day.SES	4 (seconds)	0 - 86400
MRC-12.pmthresholds.oc3.line.nearend.1day.UAS	10 (seconds)	0 - 86400
MRC-12.pmthresholds.oc3.section.nearend.15min.CV	10000 (B1 count)	0 - 138600
MRC-12.pmthresholds.oc3.section.nearend.15min.ES	500 (seconds)	0 - 900
MRC-12.pmthresholds.oc3.section.nearend.15min.SEFS	500 (seconds)	0 - 900
MRC-12.pmthresholds.oc3.section.nearend.15min.SES	500 (seconds)	0 - 900
MRC-12.pmthresholds.oc3.section.nearend.1day.CV	100000 (B1 count)	0 - 13305600
MRC-12.pmthresholds.oc3.section.nearend.1day.ES	5000 (seconds)	0 - 86400
MRC-12.pmthresholds.oc3.section.nearend.1day.SEFS	5000 (seconds)	0 - 86400
MRC-12.pmthresholds.oc3.section.nearend.1day.SES	5000 (seconds)	0 - 86400
MRC-12.pmthresholds.oc3.sts1.farend.15min.CV	15 (B3 count)	0 - 2160000
MRC-12.pmthresholds.oc3.sts1.farend.15min.ES	12 (seconds)	0 - 900
MRC-12.pmthresholds.oc3.sts1.farend.15min.FC	10 (count)	0 - 72
MRC-12.pmthresholds.oc3.sts1.farend.15min.SES	3 (seconds)	0 - 900
MRC-12.pmthresholds.oc3.sts1.farend.15min.UAS	10 (seconds)	0 - 900
MRC-12.pmthresholds.oc3.sts1.farend.1day.CV	125 (B3 count)	0 - 207360000
MRC-12.pmthresholds.oc3.sts1.farend.1day.ES	100 (seconds)	0 - 86400

Table C-19 MRC-12 Card Default Settings (continued)

Default Name	Default Value	Default Domain
MRC-12.pmthresholds.oc3.sts1.farend.1day.FC	40 (count)	0 - 6912
MRC-12.pmthresholds.oc3.sts1.farend.1day.SES	7 (seconds)	0 - 86400
MRC-12.pmthresholds.oc3.sts1.farend.1day.UAS	10 (seconds)	0 - 86400
MRC-12.pmthresholds.oc3.sts1.nearend.15min.CV	15 (B3 count)	0 - 2160000
MRC-12.pmthresholds.oc3.sts1.nearend.15min.ES	12 (seconds)	0 - 900
MRC-12.pmthresholds.oc3.sts1.nearend.15min.FC	10 (count)	0 - 72
MRC-12.pmthresholds.oc3.sts1.nearend.15min.NPJC-PDET	60 (count)	0 - 7200000
MRC-12.pmthresholds.oc3.sts1.nearend.15min.NPJC-PGEN	60 (count)	0 - 7200000
MRC-12.pmthresholds.oc3.sts1.nearend.15min.PJCDIFF	60 (count)	0 - 1200
MRC-12.pmthresholds.oc3.sts1.nearend.15min.PJCS-PDET	100 (seconds)	0 - 7200000
MRC-12.pmthresholds.oc3.sts1.nearend.15min.PJCS-PGEN	100 (seconds)	0 - 7200000
MRC-12.pmthresholds.oc3.sts1.nearend.15min.PPJC-PDET	60 (count)	0 - 7200000
MRC-12.pmthresholds.oc3.sts1.nearend.15min.PPJC-PGEN	60 (count)	0 - 7200000
MRC-12.pmthresholds.oc3.sts1.nearend.15min.SES	3 (seconds)	0 - 900
MRC-12.pmthresholds.oc3.sts1.nearend.15min.UAS	10 (seconds)	0 - 900
MRC-12.pmthresholds.oc3.sts1.nearend.1day.CV	125 (B3 count)	0 - 207360000
MRC-12.pmthresholds.oc3.sts1.nearend.1day.ES	100 (seconds)	0 - 86400
MRC-12.pmthresholds.oc3.sts1.nearend.1day.FC	40 (count)	0 - 6912
MRC-12.pmthresholds.oc3.sts1.nearend.1day.NPJC-PDET	5760 (count)	0 - 691200000
MRC-12.pmthresholds.oc3.sts1.nearend.1day.NPJC-PGEN	5760 (count)	0 - 691200000
MRC-12.pmthresholds.oc3.sts1.nearend.1day.PJCDIFF	5760 (count)	0 - 115200
MRC-12.pmthresholds.oc3.sts1.nearend.1day.PJCS-PDET	9600 (seconds)	0 - 691200000
MRC-12.pmthresholds.oc3.sts1.nearend.1day.PJCS-PGEN	9600 (seconds)	0 - 691200000
MRC-12.pmthresholds.oc3.sts1.nearend.1day.PPJC-PDET	5760 (count)	0 - 691200000
MRC-12.pmthresholds.oc3.sts1.nearend.1day.PPJC-PGEN	5760 (count)	0 - 691200000
MRC-12.pmthresholds.oc3.sts1.nearend.1day.SES	7 (seconds)	0 - 86400
MRC-12.pmthresholds.oc3.sts1.nearend.1day.UAS	10 (seconds)	0 - 86400
MRC-12.pmthresholds.oc3.sts3c.farend.15min.CV	25 (B3 count)	0 - 2160000
MRC-12.pmthresholds.oc3.sts3c.farend.15min.ES	20 (seconds)	0 - 900
MRC-12.pmthresholds.oc3.sts3c.farend.15min.FC	10 (count)	0 - 72
MRC-12.pmthresholds.oc3.sts3c.farend.15min.SES	3 (seconds)	0 - 900
MRC-12.pmthresholds.oc3.sts3c.farend.15min.UAS	10 (seconds)	0 - 900
MRC-12.pmthresholds.oc3.sts3c.farend.1day.CV	250 (B3 count)	0 - 207360000
MRC-12.pmthresholds.oc3.sts3c.farend.1day.ES	200 (seconds)	0 - 86400
MRC-12.pmthresholds.oc3.sts3c.farend.1day.FC	40 (count)	0 - 6912
MRC-12.pmthresholds.oc3.sts3c.farend.1day.SES	7 (seconds)	0 - 86400

Table C-19 MRC-12 Card Default Settings (continued)

Default Name	Default Value	Default Domain
MRC-12.pmthresholds.oc3.sts3c.farend.1day.UAS	10 (seconds)	0 - 86400
MRC-12.pmthresholds.oc3.sts3c.nearend.15min.CV	25 (B3 count)	0 - 2160000
MRC-12.pmthresholds.oc3.sts3c.nearend.15min.ES	20 (seconds)	0 - 900
MRC-12.pmthresholds.oc3.sts3c.nearend.15min.FC	10 (count)	0 - 72
MRC-12.pmthresholds.oc3.sts3c.nearend.15min.NPJC-PDET	60 (count)	0 - 7200000
MRC-12.pmthresholds.oc3.sts3c.nearend.15min.NPJC-PGEN	60 (count)	0 - 7200000
MRC-12.pmthresholds.oc3.sts3c.nearend.15min.PJCDIFF	60 (count)	0 - 1200
MRC-12.pmthresholds.oc3.sts3c.nearend.15min.PJCS-PDET	100 (seconds)	0 - 7200000
MRC-12.pmthresholds.oc3.sts3c.nearend.15min.PJCS-PGEN	100 (seconds)	0 - 7200000
MRC-12.pmthresholds.oc3.sts3c.nearend.15min.PPJC-PDET	60 (count)	0 - 7200000
MRC-12.pmthresholds.oc3.sts3c.nearend.15min.PPJC-PGEN	60 (count)	0 - 7200000
MRC-12.pmthresholds.oc3.sts3c.nearend.15min.SES	3 (seconds)	0 - 900
MRC-12.pmthresholds.oc3.sts3c.nearend.15min.UAS	10 (seconds)	0 - 900
MRC-12.pmthresholds.oc3.sts3c.nearend.1day.CV	250 (B3 count)	0 - 207360000
MRC-12.pmthresholds.oc3.sts3c.nearend.1day.ES	200 (seconds)	0 - 86400
MRC-12.pmthresholds.oc3.sts3c.nearend.1day.FC	40 (count)	0 - 6912
MRC-12.pmthresholds.oc3.sts3c.nearend.1day.NPJC-PDET	5760 (count)	0 - 691200000
MRC-12.pmthresholds.oc3.sts3c.nearend.1day.NPJC-PGEN	5760 (count)	0 - 691200000
MRC-12.pmthresholds.oc3.sts3c.nearend.1day.PJCDIFF	5760 (count)	0 - 115200
MRC-12.pmthresholds.oc3.sts3c.nearend.1day.PJCS-PDET	9600 (seconds)	0 - 691200000
MRC-12.pmthresholds.oc3.sts3c.nearend.1day.PJCS-PGEN	9600 (seconds)	0 - 691200000
MRC-12.pmthresholds.oc3.sts3c.nearend.1day.PPJC-PDET	5760 (count)	0 - 691200000
MRC-12.pmthresholds.oc3.sts3c.nearend.1day.PPJC-PGEN	5760 (count)	0 - 691200000
MRC-12.pmthresholds.oc3.sts3c.nearend.1day.SES	7 (seconds)	0 - 86400
MRC-12.pmthresholds.oc3.sts3c.nearend.1day.UAS	10 (seconds)	0 - 86400
MRC-12.pmthresholds.oc48.line.farend.15min.CV	21260 (B2 count)	0 - 2212200
MRC-12.pmthresholds.oc48.line.farend.15min.ES	87 (seconds)	0 - 900
MRC-12.pmthresholds.oc48.line.farend.15min.FC	10 (count)	0 - 72
MRC-12.pmthresholds.oc48.line.farend.15min.SES	1 (seconds)	0 - 900
MRC-12.pmthresholds.oc48.line.farend.15min.UAS	3 (seconds)	0 - 900
MRC-12.pmthresholds.oc48.line.farend.1day.CV	212600 (B2 count)	0 - 212371200
MRC-12.pmthresholds.oc48.line.farend.1day.ES	864 (seconds)	0 - 86400
MRC-12.pmthresholds.oc48.line.farend.1day.FC	40 (count)	0 - 6912
MRC-12.pmthresholds.oc48.line.farend.1day.SES	4 (seconds)	0 - 86400
MRC-12.pmthresholds.oc48.line.farend.1day.UAS	10 (seconds)	0 - 86400
MRC-12.pmthresholds.oc48.line.nearend.15min.CV	21260 (B2 count)	0 - 2212200

Table C-19 MRC-12 Card Default Settings (continued)

Default Name	Default Value	Default Domain
MRC-12.pmthresholds.oc48.line.nearend.15min.ES	87 (seconds)	0 - 900
MRC-12.pmthresholds.oc48.line.nearend.15min.FC	10 (count)	0 - 72
MRC-12.pmthresholds.oc48.line.nearend.15min.PSC	1 (count)	0 - 600
MRC-12.pmthresholds.oc48.line.nearend.15min.PSC-R	1 (count)	0 - 600
MRC-12.pmthresholds.oc48.line.nearend.15min.PSC-S	1 (count)	0 - 600
MRC-12.pmthresholds.oc48.line.nearend.15min.PSC-W	1 (count)	0 - 600
MRC-12.pmthresholds.oc48.line.nearend.15min.PSD	300 (seconds)	0 - 600
MRC-12.pmthresholds.oc48.line.nearend.15min.PSD-R	300 (seconds)	0 - 900
MRC-12.pmthresholds.oc48.line.nearend.15min.PSD-S	300 (seconds)	0 - 900
MRC-12.pmthresholds.oc48.line.nearend.15min.PSD-W	300 (seconds)	0 - 900
MRC-12.pmthresholds.oc48.line.nearend.15min.SES	1 (seconds)	0 - 900
MRC-12.pmthresholds.oc48.line.nearend.15min.UAS	3 (seconds)	0 - 900
MRC-12.pmthresholds.oc48.line.nearend.1day.CV	212600 (B2 count)	0 - 212371200
MRC-12.pmthresholds.oc48.line.nearend.1day.ES	864 (seconds)	0 - 86400
MRC-12.pmthresholds.oc48.line.nearend.1day.FC	40 (count)	0 - 6912
MRC-12.pmthresholds.oc48.line.nearend.1day.PSC	5 (count)	0 - 57600
MRC-12.pmthresholds.oc48.line.nearend.1day.PSC-R	5 (count)	0 - 57600
MRC-12.pmthresholds.oc48.line.nearend.1day.PSC-S	5 (count)	0 - 57600
MRC-12.pmthresholds.oc48.line.nearend.1day.PSC-W	5 (count)	0 - 57600
MRC-12.pmthresholds.oc48.line.nearend.1day.PSD	600 (seconds)	0 - 86400
MRC-12.pmthresholds.oc48.line.nearend.1day.PSD-R	600 (seconds)	0 - 86400
MRC-12.pmthresholds.oc48.line.nearend.1day.PSD-S	600 (seconds)	0 - 86400
MRC-12.pmthresholds.oc48.line.nearend.1day.PSD-W	600 (seconds)	0 - 86400
MRC-12.pmthresholds.oc48.line.nearend.1day.SES	4 (seconds)	0 - 86400
MRC-12.pmthresholds.oc48.line.nearend.1day.UAS	10 (seconds)	0 - 86400
MRC-12.pmthresholds.oc48.section.nearend.15min.CV	10000 (B1 count)	0 - 2151900
MRC-12.pmthresholds.oc48.section.nearend.15min.ES	500 (seconds)	0 - 900
MRC-12.pmthresholds.oc48.section.nearend.15min.SEFS	500 (seconds)	0 - 900
MRC-12.pmthresholds.oc48.section.nearend.15min.SES	500 (seconds)	0 - 900
MRC-12.pmthresholds.oc48.section.nearend.1day.CV	100000 (B1 count)	0 - 206582400
MRC-12.pmthresholds.oc48.section.nearend.1day.ES	5000 (seconds)	0 - 86400
MRC-12.pmthresholds.oc48.section.nearend.1day.SEFS	5000 (seconds)	0 - 86400
MRC-12.pmthresholds.oc48.section.nearend.1day.SES	5000 (seconds)	0 - 86400
MRC-12.pmthresholds.oc48.sts1.farend.15min.CV	15 (B3 count)	0 - 2160000
MRC-12.pmthresholds.oc48.sts1.farend.15min.ES	12 (seconds)	0 - 900
MRC-12.pmthresholds.oc48.sts1.farend.15min.FC	10 (count)	0 - 72

Table C-19 MRC-12 Card Default Settings (continued)

Default Name	Default Value	Default Domain
MRC-12.pmthresholds.oc48.sts1.farend.15min.SES	3 (seconds)	0 - 900
MRC-12.pmthresholds.oc48.sts1.farend.15min.UAS	10 (seconds)	0 - 900
MRC-12.pmthresholds.oc48.sts1.farend.1day.CV	125 (B3 count)	0 - 207360000
MRC-12.pmthresholds.oc48.sts1.farend.1day.ES	100 (seconds)	0 - 86400
MRC-12.pmthresholds.oc48.sts1.farend.1day.FC	40 (count)	0 - 6912
MRC-12.pmthresholds.oc48.sts1.farend.1day.SES	7 (seconds)	0 - 86400
MRC-12.pmthresholds.oc48.sts1.farend.1day.UAS	10 (seconds)	0 - 86400
MRC-12.pmthresholds.oc48.sts1.nearend.15min.CV	15 (B3 count)	0 - 2160000
MRC-12.pmthresholds.oc48.sts1.nearend.15min.ES	12 (seconds)	0 - 900
MRC-12.pmthresholds.oc48.sts1.nearend.15min.FC	10 (count)	0 - 72
MRC-12.pmthresholds.oc48.sts1.nearend.15min.NPJC-PDET	60 (count)	0 - 7200000
MRC-12.pmthresholds.oc48.sts1.nearend.15min.NPJC-PGEN	60 (count)	0 - 7200000
MRC-12.pmthresholds.oc48.sts1.nearend.15min.PJCDIFF	60 (count)	0 - 1200
MRC-12.pmthresholds.oc48.sts1.nearend.15min.PJCS-PDET	100 (seconds)	0 - 7200000
MRC-12.pmthresholds.oc48.sts1.nearend.15min.PJCS-PGEN	100 (seconds)	0 - 7200000
MRC-12.pmthresholds.oc48.sts1.nearend.15min.PPJC-PDET	60 (count)	0 - 7200000
MRC-12.pmthresholds.oc48.sts1.nearend.15min.PPJC-PGEN	60 (count)	0 - 7200000
MRC-12.pmthresholds.oc48.sts1.nearend.15min.SES	3 (seconds)	0 - 900
MRC-12.pmthresholds.oc48.sts1.nearend.15min.UAS	10 (seconds)	0 - 900
MRC-12.pmthresholds.oc48.sts1.nearend.1day.CV	125 (B3 count)	0 - 207360000
MRC-12.pmthresholds.oc48.sts1.nearend.1day.ES	100 (seconds)	0 - 86400
MRC-12.pmthresholds.oc48.sts1.nearend.1day.FC	40 (count)	0 - 6912
MRC-12.pmthresholds.oc48.sts1.nearend.1day.NPJC-PDET	5760 (count)	0 - 691200000
MRC-12.pmthresholds.oc48.sts1.nearend.1day.NPJC-PGEN	5760 (count)	0 - 691200000
MRC-12.pmthresholds.oc48.sts1.nearend.1day.PJCDIFF	5760 (count)	0 - 115200
MRC-12.pmthresholds.oc48.sts1.nearend.1day.PJCS-PDET	9600 (seconds)	0 - 691200000
MRC-12.pmthresholds.oc48.sts1.nearend.1day.PJCS-PGEN	9600 (seconds)	0 - 691200000
MRC-12.pmthresholds.oc48.sts1.nearend.1day.PPJC-PDET	5760 (count)	0 - 691200000
MRC-12.pmthresholds.oc48.sts1.nearend.1day.PPJC-PGEN	5760 (count)	0 - 691200000
MRC-12.pmthresholds.oc48.sts1.nearend.1day.SES	7 (seconds)	0 - 86400
MRC-12.pmthresholds.oc48.sts1.nearend.1day.UAS	10 (seconds)	0 - 86400
MRC-12.pmthresholds.oc48.sts12c-48c.farend.15min.CV	75 (B3 count)	0 - 2160000
MRC-12.pmthresholds.oc48.sts12c-48c.farend.15min.ES	60 (seconds)	0 - 900
MRC-12.pmthresholds.oc48.sts12c-48c.farend.15min.FC	10 (count)	0 - 72
MRC-12.pmthresholds.oc48.sts12c-48c.farend.15min.SES	3 (seconds)	0 - 900
MRC-12.pmthresholds.oc48.sts12c-48c.farend.15min.UAS	10 (seconds)	0 - 900

Table C-19 MRC-12 Card Default Settings (continued)

Default Name	Default Value	Default Domain
MRC-12.pmthresholds.oc48.sts12c-48c.farend.1day.CV	750 (B3 count)	0 - 207360000
MRC-12.pmthresholds.oc48.sts12c-48c.farend.1day.ES	600 (seconds)	0 - 86400
MRC-12.pmthresholds.oc48.sts12c-48c.farend.1day.FC	40 (count)	0 - 6912
MRC-12.pmthresholds.oc48.sts12c-48c.farend.1day.SES	7 (seconds)	0 - 86400
MRC-12.pmthresholds.oc48.sts12c-48c.farend.1day.UAS	10 (seconds)	0 - 86400
MRC-12.pmthresholds.oc48.sts12c-48c.nearend.15min.CV	75 (B3 count)	0 - 2160000
MRC-12.pmthresholds.oc48.sts12c-48c.nearend.15min.ES	60 (seconds)	0 - 900
MRC-12.pmthresholds.oc48.sts12c-48c.nearend.15min.FC	10 (count)	0 - 72
MRC-12.pmthresholds.oc48.sts12c-48c.nearend.15min.NPJC-PDET	60 (count)	0 - 7200000
MRC-12.pmthresholds.oc48.sts12c-48c.nearend.15min.NPJC-PGEN	60 (count)	0 - 7200000
MRC-12.pmthresholds.oc48.sts12c-48c.nearend.15min.PJCDIFF	60 (count)	0 - 1200
MRC-12.pmthresholds.oc48.sts12c-48c.nearend.15min.PJCS-PDET	100 (seconds)	0 - 7200000
MRC-12.pmthresholds.oc48.sts12c-48c.nearend.15min.PJCS-PGEN	100 (seconds)	0 - 7200000
MRC-12.pmthresholds.oc48.sts12c-48c.nearend.15min.PPJC-PDET	60 (count)	0 - 7200000
MRC-12.pmthresholds.oc48.sts12c-48c.nearend.15min.PPJC-PGEN	60 (count)	0 - 7200000
MRC-12.pmthresholds.oc48.sts12c-48c.nearend.15min.SES	3 (seconds)	0 - 900
MRC-12.pmthresholds.oc48.sts12c-48c.nearend.15min.UAS	10 (seconds)	0 - 900
MRC-12.pmthresholds.oc48.sts12c-48c.nearend.1day.CV	750 (B3 count)	0 - 207360000
MRC-12.pmthresholds.oc48.sts12c-48c.nearend.1day.ES	600 (seconds)	0 - 86400
MRC-12.pmthresholds.oc48.sts12c-48c.nearend.1day.FC	40 (count)	0 - 6912
MRC-12.pmthresholds.oc48.sts12c-48c.nearend.1day.NPJC-PDET	5760 (count)	0 - 691200000
MRC-12.pmthresholds.oc48.sts12c-48c.nearend.1day.NPJC-PGEN	5760 (count)	0 - 691200000
MRC-12.pmthresholds.oc48.sts12c-48c.nearend.1day.PJCDIFF	5760 (count)	0 - 115200
MRC-12.pmthresholds.oc48.sts12c-48c.nearend.1day.PJCS-PDET	9600 (seconds)	0 - 691200000
MRC-12.pmthresholds.oc48.sts12c-48c.nearend.1day.PJCS-PGEN	9600 (seconds)	0 - 691200000
MRC-12.pmthresholds.oc48.sts12c-48c.nearend.1day.PPJC-PDET	5760 (count)	0 - 691200000
MRC-12.pmthresholds.oc48.sts12c-48c.nearend.1day.PPJC-PGEN	5760 (count)	0 - 691200000
MRC-12.pmthresholds.oc48.sts12c-48c.nearend.1day.SES	7 (seconds)	0 - 86400
MRC-12.pmthresholds.oc48.sts12c-48c.nearend.1day.UAS	10 (seconds)	0 - 86400
MRC-12.pmthresholds.oc48.sts3c-9c.farend.15min.CV	25 (B3 count)	0 - 2160000
MRC-12.pmthresholds.oc48.sts3c-9c.farend.15min.ES	20 (seconds)	0 - 900
MRC-12.pmthresholds.oc48.sts3c-9c.farend.15min.FC	10 (count)	0 - 72
MRC-12.pmthresholds.oc48.sts3c-9c.farend.15min.SES	3 (seconds)	0 - 900
MRC-12.pmthresholds.oc48.sts3c-9c.farend.15min.UAS	10 (seconds)	0 - 900
MRC-12.pmthresholds.oc48.sts3c-9c.farend.1day.CV	250 (B3 count)	0 - 207360000
MRC-12.pmthresholds.oc48.sts3c-9c.farend.1day.ES	200 (seconds)	0 - 86400

Table C-19 MRC-12 Card Default Settings (continued)

Default Name	Default Value	Default Domain
MRC-12.pmthresholds.oc48.sts3c-9c.farend.1day.FC	40 (count)	0 - 6912
MRC-12.pmthresholds.oc48.sts3c-9c.farend.1day.SES	7 (seconds)	0 - 86400
MRC-12.pmthresholds.oc48.sts3c-9c.farend.1day.UAS	10 (seconds)	0 - 86400
MRC-12.pmthresholds.oc48.sts3c-9c.nearend.15min.CV	25 (B3 count)	0 - 2160000
MRC-12.pmthresholds.oc48.sts3c-9c.nearend.15min.ES	20 (seconds)	0 - 900
MRC-12.pmthresholds.oc48.sts3c-9c.nearend.15min.FC	10 (count)	0 - 72
MRC-12.pmthresholds.oc48.sts3c-9c.nearend.15min.NPJC-PDET	60 (count)	0 - 7200000
MRC-12.pmthresholds.oc48.sts3c-9c.nearend.15min.NPJC-PGEN	60 (count)	0 - 7200000
MRC-12.pmthresholds.oc48.sts3c-9c.nearend.15min.PJCDIFF	60 (count)	0 - 1200
MRC-12.pmthresholds.oc48.sts3c-9c.nearend.15min.PJCS-PDET	100 (seconds)	0 - 7200000
MRC-12.pmthresholds.oc48.sts3c-9c.nearend.15min.PJCS-PGEN	100 (seconds)	0 - 7200000
MRC-12.pmthresholds.oc48.sts3c-9c.nearend.15min.PPJC-PDET	60 (count)	0 - 7200000
MRC-12.pmthresholds.oc48.sts3c-9c.nearend.15min.PPJC-PGEN	60 (count)	0 - 7200000
MRC-12.pmthresholds.oc48.sts3c-9c.nearend.15min.SES	3 (seconds)	0 - 900
MRC-12.pmthresholds.oc48.sts3c-9c.nearend.15min.UAS	10 (seconds)	0 - 900
MRC-12.pmthresholds.oc48.sts3c-9c.nearend.1day.CV	250 (B3 count)	0 - 207360000
MRC-12.pmthresholds.oc48.sts3c-9c.nearend.1day.ES	200 (seconds)	0 - 86400
MRC-12.pmthresholds.oc48.sts3c-9c.nearend.1day.FC	40 (count)	0 - 6912
MRC-12.pmthresholds.oc48.sts3c-9c.nearend.1day.NPJC-PDET	5760 (count)	0 - 691200000
MRC-12.pmthresholds.oc48.sts3c-9c.nearend.1day.NPJC-PGEN	5760 (count)	0 - 691200000
MRC-12.pmthresholds.oc48.sts3c-9c.nearend.1day.PJCDIFF	5760 (count)	0 - 115200
MRC-12.pmthresholds.oc48.sts3c-9c.nearend.1day.PJCS-PDET	9600 (seconds)	0 - 691200000
MRC-12.pmthresholds.oc48.sts3c-9c.nearend.1day.PJCS-PGEN	9600 (seconds)	0 - 691200000
MRC-12.pmthresholds.oc48.sts3c-9c.nearend.1day.PPJC-PDET	5760 (count)	0 - 691200000
MRC-12.pmthresholds.oc48.sts3c-9c.nearend.1day.PPJC-PGEN	5760 (count)	0 - 691200000
MRC-12.pmthresholds.oc48.sts3c-9c.nearend.1day.SES	7 (seconds)	0 - 86400
MRC-12.pmthresholds.oc48.sts3c-9c.nearend.1day.UAS	10 (seconds)	0 - 86400

C.3 Node Default Settings

Table C-20 on page C-76 lists the node-level default settings for the Cisco ONS 15454. Cisco provides the following user-configurable defaults for each Cisco ONS 15454 node:

- Circuit settings—Set the administrative state and path protection circuit defaults, and whether to have circuits send a payload defect indication condition (PDIP).
- General settings—Set general node management defaults, including whether to use Daylight Savings Time (DST), whether to insert Alarm Indication Signal VT (AIS-V) in each VT when the carrying STS crosses the signal degrade (SD) path bit error rate (BER) threshold, the IP address of

the NTP/SNTP server to be used, the time zone where the node is located, the SD path BER value, the defaults description, whether to raise a condition on an empty card slot, and whether to report loopback conditions on Out-of-Service, Maintenance (OOS-MT) state ports.

- Power Monitor settings—Set default voltage thresholds for the node.
- Network settings—Set whether to prevent display of node IP addresses in CTC (applicable for all users except Superusers); default gateway node type; whether to raise an alarm when the backplane LAN cable is disconnected; and whether to display the IP address in the LCD in an editable mode (in which you can change the IP address directly from LCD screen), to display the IP address on the LCD as read-only, or to suppress display of the IP on the LCD entirely.
- OSI settings—Set Open System Interconnection (OSI) main setup, generic routing encapsulation (GRE) tunnel, link access protocol on the D channel (LAP-D), router subnet, and TID address resolution protocol (TARP) settings.
- 1+1 and Optimized 1+1 protection settings—Set whether or not protected circuits have bidirectional switching, are revertive, and what the reversion time is; set optimized 1+1 detection, recovery, and verify guard timer values.



Note Optimized 1+1 supports three timers that ensure the correct state of the cards at key points in card communication. A verification guard timer is used when a Force is issued, to ensure that the far end has a chance to respond. A detection guard timer is used to ensure the presence of an SF/SD condition before switching away from a card. A recover guard timer ensures the absence of SF/SD prior to switching to a card. You can change the default number of seconds before these timers expire by changing the NE default for the corresponding timer to a value within its domain of allowable values.

- BLSR protection settings—Set whether BLSR-protected circuits are revertive, and what the reversion time is, at both the ring and span levels.
- Legal Disclaimer—Set the legal disclaimer that warns users at the login screen about the possible legal or contractual ramifications of accessing equipment, systems, or networks without authorization.
- Security Grant Permissions—Set default user security levels for activating/reverting software, performance monitoring data clearing, database restoring, and retrieving audit logs.
- Security DataComm settings—Set default security settings for TCC Ethernet IP address and IP netmask, and CTC backplane IP suppression; set secure mode on and secure mode locked (for TCC2P cards only).
- Security Access settings—Set default security settings for LAN access, shell access, serial craft access, element management system (EMS) access (including Internet Inter-Object Request Broker Protocol [IIOP] listener port number), TL1 access, and SNMP access.
- Security RADIUS settings—Set default RADIUS server settings for accounting port number, authentication port number, and whether to enable the node as a final authenticator.
- Security Policy settings—Set the allowable failed logins before lockout, idle user timeout for each user-level, optional lockout duration or manual unlock enabled, password reuse and change frequency policies, number of characters difference between the old and new password, password aging by security level, enforced single concurrent session per user, and option to disable inactive user after a set inactivity period.
- BITS Timing settings—Set the AIS threshold, Admin SSM, coding, facility type, framing, state, and line build-out (LBO) settings for building integrated timing supply 1 (BITS-1) and BITS2 timing.

- General Timing settings—Set the mode (External, Line, or Mixed), quality of reserved (RES) timing (set the rule that defines the order of clock quality from lowest to highest), revertive, reversion time, and SSM message set for node timing.

**Note**

Any node level defaults changed using the **Provisioning > Defaults** tab, changes existing node level provisioning. Although this is service affecting, it depends on the type of defaults changed, for example, general, and all timing and security attributes. The “Changing default values for some node level attributes overrides the current provisioning.” message is displayed. The Side Effects column of the Defaults editor (right-click a column header and select **Show Column > Side Effects**) explains the effect of changing the default values. However, when the card level defaults are changed using the **Provisioning > Defaults** tab, existing card provisioning remains unaffected.

**Note**

For more information about each individual node setting, refer to the “Change Node Settings” chapter of the *Cisco ONS 15454 Procedure Guide*.

Table C-20 Node Default Settings

Default Name	Default Value	Default Domain
NODE.circuits.SendPDIP	FALSE	TRUE, FALSE
NODE.circuits.State	IS,AINS	IS, OOS,DSBLD, OOS,MT, IS,AINS
NODE.circuits.upsr.AllowUpsrOverOnePlusOne	FALSE	TRUE, FALSE
NODE.circuits.upsr.ReversionTime	5.0 (minutes)	0.5, 1.0, 1.5 .. 12.0
NODE.circuits.upsr.Revertive	FALSE	TRUE, FALSE
NODE.circuits.upsr.STS_SDBER	1E-6	1E-5, 1E-6, 1E-7, 1E-8, 1E-9
NODE.circuits.upsr.STS_SFBER	1E-4	1E-3, 1E-4, 1E-5
NODE.circuits.upsr.SwitchOnPDIP	FALSE	TRUE, FALSE
NODE.circuits.upsr.VT_SDBER	1E-6	1E-5, 1E-6, 1E-7, 1E-8
NODE.circuits.upsr.VT_SFBER	1E-4	1E-3, 1E-4, 1E-5
NODE.general.DefaultsDescription	Factory Defaults	Free form field
NODE.general.InsertAISVOnSDP	FALSE	TRUE, FALSE
NODE.general.NtpSntpServer	0.0.0.0	IP Address
NODE.general.RaiseConditionOnEmptySlot	FALSE	TRUE, FALSE
NODE.general.SDPBER	1E-6	1E-5, 1E-6, 1E-7, 1E-8, 1E-9
NODE.general.ShowLoopbackAlarmsOnPortsUndergoingMaintenance	FALSE	FALSE, TRUE
NODE.general.TimeZone	(GMT-08:00) Pacific Time (US & Canada), Tijuana	(For applicable time zones, see Table C-21 on page C-83.)

Table C-20 Node Default Settings (continued)

Default Name	Default Value	Default Domain
NODE.general.UseDST	TRUE	TRUE, FALSE
NODE.network.general.AlarmMissingBackplaneLAN	FALSE	TRUE, FALSE
NODE.network.general.CtcIpDisplaySuppression	FALSE	TRUE, FALSE
NODE.network.general.GatewaySettings	None	LeaveAsIs, None, ENE, GNE, ProxyOnlyNode
NODE.network.general.LcdIpSetting	Allow Configuration	Allow Configuration, Display Only, Suppress Display
NODE.osi.greTunnel.OspfCost	110	110, 120, 130 .. 65530
NODE.osi.greTunnel.SubnetMask	24 (bits)	8, 9, 10 .. 32
NODE.osi.lapd.Mode	AITS	AITS, UITS
NODE.osi.lapd.MTU	512	512, 513, 514 .. 1500
NODE.osi.lapd.Role	Network	Network, User
NODE.osi.lapd.T200	200 (ms)	200, 300, 400 .. 20000
NODE.osi.lapd.T203	10000 (ms)	4000, 4100, 4200 .. 120000
NODE.osi.mainSetup.L1L2LSPBufferSize	512 (bytes)	512 - 1500
NODE.osi.mainSetup.L1LSPBufferSize	512 (bytes)	512 - 1500
NODE.osi.mainSetup.NodeRoutingMode	Intermediate System Level 1	End System, Intermediate System Level 1, Intermediate System Level 1/Level 2
NODE.osi.subnet.DISPriority	63	1, 2, 3 .. 127
NODE.osi.subnet.ESH	10 (sec)	10, 20, 30 .. 1000
NODE.osi.subnet.GCCISISCost	60	1, 2, 3 .. 63
NODE.osi.subnet.IIH	3 (sec)	1, 2, 3 .. 600
NODE.osi.subnet.ISH	10 (sec)	10, 20, 30 .. 1000
NODE.osi.subnet.LANISISCost	20	1, 2, 3 .. 63
NODE.osi.subnet.LDCCISISCost	40	1, 2, 3 .. 63
NODE.osi.subnet.OSCISISCost	60	1, 2, 3 .. 63
NODE.osi.subnet.SDCCISISCost	60	1, 2, 3 .. 63
NODE.osi.tarp.L1DataCache	TRUE	FALSE, TRUE
NODE.osi.tarp.L2DataCache	FALSE	FALSE, TRUE
NODE.osi.tarp.LANStormSuppression	TRUE	FALSE, TRUE
NODE.osi.tarp.LDB	TRUE	FALSE, TRUE
NODE.osi.tarp.LDBEntry	5 (min)	1 - 10
NODE.osi.tarp.LDBFlush	5 (min)	0 - 1440
NODE.osi.tarp.PDU sL1Propagation	TRUE	FALSE, TRUE

Table C-20 Node Default Settings (continued)

Default Name	Default Value	Default Domain
NODE.osi.tarp.PDUsL2Propagation	TRUE	FALSE, TRUE
NODE.osi.tarp.PDUsOrigination	TRUE	FALSE, TRUE
NODE.osi.tarp.T1Timer	15 (sec)	0 - 3600
NODE.osi.tarp.T2Timer	25 (sec)	0 - 3600
NODE.osi.tarp.T3Timer	40 (sec)	0 - 3600
NODE.osi.tarp.T4Timer	20 (sec)	0 - 3600
NODE.osi.tarp.Type4PDUDelay	0 (sec)	0 - 255
NODE.powerMonitor.EHIBATVG	-56.5 (Vdc)	-54.0, -54.5, -55.0, -55.5, -56.0, -56.5
NODE.powerMonitor.ELWBATVG	-40.5 (Vdc)	-40.5, -41.0, -41.5, -42.0, -42.5, -43.0, -43.5, -44.0
NODE.powerMonitor.HIBATVG	-54.0 (Vdc)	-44.0, -44.5, -45.0 .. -56.5
NODE.powerMonitor.LWBATVG	-44.0 (Vdc)	-40.5, -41.0, -41.5 .. -54.0
NODE.protection.1+1.BidirectionalSwitching	FALSE	TRUE, FALSE
NODE.protection.1+1.DetectionGuardTimer	1 (seconds)	0, 0.05, 0.1, 0.5, 1, 2, 3, 4, 5
NODE.protection.1+1.RecoveryGuardTimer	1 (seconds)	0, 0.05, 0.1 .. 10
NODE.protection.1+1.ReversionTime	5.0 (minutes)	0.5, 1.0, 1.5 .. 12.0
NODE.protection.1+1.Revertive	FALSE	TRUE, FALSE
NODE.protection.1+1.VerifyGuardTimer	0.5 (seconds)	0.5, 1
NODE.protection.blsr.RingReversionTime	5.0 (minutes)	0.5, 1.0, 1.5 .. 12.0
NODE.protection.blsr.RingRevertive	TRUE	TRUE, FALSE
NODE.protection.blsr.SpanReversionTime	5.0 (minutes)	0.5, 1.0, 1.5 .. 12.0
NODE.protection.blsr.SpanRevertive	TRUE	TRUE, FALSE
NODE.protection.splitter.ReversionTime	5.0 (minutes)	0.5, 1.0, 1.5 .. 12.0
NODE.protection.splitter.Revertive	FALSE	TRUE, FALSE
NODE.protection.ycable.ReversionTime	5.0 (minutes)	0.5, 1.0, 1.5 .. 12.0
NODE.protection.ycable.Revertive	FALSE	TRUE, FALSE
NODE.security.dataComm.CtcBackplaneIpDisplaySuppression	TRUE	FALSE, TRUE when isSecureModeSupportedOnControlCard TRUE; (NOT SUPPORTED) when isSecureModeSupportedOnControlCard FALSE
NODE.security.dataComm.DefaultTCCEthernetIP	10.0.0.1	IP Address
NODE.security.dataComm.DefaultTCCEthernetIPNetmask	24 (bits)	8, 9, 10 .. 32
NODE.security.dataComm.isSecureModeSupportedOnControlCard	TRUE	FALSE, TRUE

Table C-20 Node Default Settings (continued)

Default Name	Default Value	Default Domain
NODE.security.dataComm.LcdBackplaneIpSetting	Display Only	Allow Configuration, Display Only, Suppress Display when isSecureModeSupportedOnControlCard TRUE; (NOT SUPPORTED) when isSecureModeSupportedOnControlCard FALSE
NODE.security.dataComm.SecureModeLocked	FALSE	FALSE, TRUE when isSecureModeSupportedOnControlCard TRUE; (NOT SUPPORTED) when isSecureModeSupportedOnControlCard FALSE
NODE.security.dataComm.SecureModeOn (May reboot node)	FALSE	FALSE, TRUE when isSecureModeSupportedOnControlCard TRUE; (NOT SUPPORTED) when isSecureModeSupportedOnControlCard FALSE
NODE.security.emsAccess.AccessState	NonSecure	NonSecure, Secure
NODE.security.emsAccess.IIOPListenerPort (May reboot node)	57790 (port #)	0 - 65535
NODE.security.grantPermission.ActivateRevertSoftware	Superuser	Provisioning, Superuser
NODE.security.grantPermission.PMClearingPrivilege	Provisioning	Provisioning, Superuser
NODE.security.grantPermission.RestoreDB	Superuser	Provisioning, Superuser
NODE.security.grantPermission.RetrieveAuditLog	Superuser	Provisioning, Superuser
NODE.security.idleUserTimeout.Maintenance	01:00 (hours:mins)	00:00, 00:01, 00:02 .. 16:39
NODE.security.idleUserTimeout.Provisioning	00:30 (hours:mins)	00:00, 00:01, 00:02 .. 16:39
NODE.security.idleUserTimeout.Retrieve	00:00 (hours:mins)	00:00, 00:01, 00:02 .. 16:39
NODE.security.idleUserTimeout.Superuser	00:15 (hours:mins)	00:00, 00:01, 00:02 .. 16:39
NODE.security.lanAccess.LANAccess (May disconnect CTC from node)	Front & Backplane	No LAN Access, Front Only, Backplane Only, Front & Backplane
NODE.security.lanAccess.RestoreTimeout	5 (minutes)	0 - 60

Table C-20 Node Default Settings (continued)

Default Name	Default Value	Default Domain
NODE.security.legalDisclaimer.LoginWarningMessage	<html><center>WARNING</center>This system is restricted to authorized users for business purposes. Unauthorized access is a violation of the law. This service may be monitored for administrative and security reasons. By proceeding, you consent to this monitoring.	Free form field
NODE.security.other.DisableInactiveUser	FALSE	FALSE, TRUE
NODE.security.other.InactiveDuration	45 (days)	1, 2, 3 .. 99 when DisableInactiveUser TRUE; 45 when DisableInactiveUser FALSE
NODE.security.other.SingleSessionPerUser	FALSE	TRUE, FALSE
NODE.security.passwordAging.EnforcePasswordAging	FALSE	TRUE, FALSE
NODE.security.passwordAging.maintenance.AgingPeriod	45 (days)	20 - 90
NODE.security.passwordAging.maintenance.WarningPeriod	5 (days)	2 - 20
NODE.security.passwordAging.provisioning.AgingPeriod	45 (days)	20 - 90
NODE.security.passwordAging.provisioning.WarningPeriod	5 (days)	2 - 20
NODE.security.passwordAging.retrieve.AgingPeriod	45 (days)	20 - 90
NODE.security.passwordAging.retrieve.WarningPeriod	5 (days)	2 - 20
NODE.security.passwordAging.superuser.AgingPeriod	45 (days)	20 - 90
NODE.security.passwordAging.superuser.WarningPeriod	5 (days)	2 - 20
NODE.security.passwordChange.CannotChangeNewPassword	FALSE	TRUE, FALSE
NODE.security.passwordChange.CannotChangeNewPasswordForNDays	20 (days)	20 - 95

Table C-20 Node Default Settings (continued)

Default Name	Default Value	Default Domain
NODE.security.passwordChange.NewPasswordMustDifferFromOldByNCharacters	1 (characters)	1 - 20
NODE.security.passwordChange.PreventReusingLastNPasswords	1 (times)	1 - 10
NODE.security.passwordChange.RequirePasswordChangeOnFirstLoginToNewAccount	FALSE	TRUE, FALSE
NODE.security.radiusServer.AccountingPort	1813 (port)	0 - 32767
NODE.security.radiusServer.AuthenticationPort	1812 (port)	0 - 32767
NODE.security.radiusServer.EnableNodeAsFinalAuthenticator	TRUE	FALSE, TRUE
NODE.security.serialCraftAccess.EnableCraftPort	TRUE	TRUE, FALSE
NODE.security.shellAccess.AccessState	NonSecure	Disabled, NonSecure, Secure
NODE.security.shellAccess.EnableShellPassword	FALSE	TRUE, FALSE
NODE.security.shellAccess.TelnetPort	23	23 - 9999
NODE.security.snmpAccess.AccessState	NonSecure	Disabled, NonSecure
NODE.security.tl1Access.AccessState	NonSecure	Disabled, NonSecure, Secure
NODE.security.userLockout.FailedLoginsAllowedBeforeLockout	5 (times)	0 - 10
NODE.security.userLockout.LockoutDuration	00:30 (mins:secs)	00:00, 00:05, 00:10 .. 10:00
NODE.security.userLockout.ManualUnlockBySuperuser	FALSE	TRUE, FALSE
NODE.timing.bits-1.AdminSSMIn	STU	PRS, STU, ST2, TNC, ST3E, ST3, SMC, ST4, DUS, RES
NODE.timing.bits-1.AISThreshold	SMC	PRS, STU, ST2, TNC, ST3E, ST3, SMC, ST4, DUS, RES
NODE.timing.bits-1.Coding	B8ZS	B8ZS, AMI when FacilityType DS1; AMI when FacilityType 64kHz+8kHz
NODE.timing.bits-1.CodingOut	B8ZS	B8ZS, AMI when FacilityTypeOut DS1; AMI when FacilityTypeOut 6MHz
NODE.timing.bits-1.FacilityType	DS1	DS1, 64kHz+8kHz
NODE.timing.bits-1.FacilityTypeOut	DS1	DS1, 6MHz
NODE.timing.bits-1.Framing	ESF	ESF, D4 when FacilityType DS1; N/A when FacilityType 64kHz+8kHz

Table C-20 Node Default Settings (continued)

Default Name	Default Value	Default Domain
NODE.timing.bits-1.FramingOut	ESF	ESF, D4 when FacilityTypeOut DS1; N/A when FacilityTypeOut 6MHz
NODE.timing.bits-1.LBO	0-133	0-133, 134-266, 267-399, 400-533, 534-655
NODE.timing.bits-1.State	IS	IS, OOS,DSBLD
NODE.timing.bits-1.StateOut	IS	IS, OOS,DSBLD
NODE.timing.bits-2.AdminSSMIn	STU	PRS, STU, ST2, TNC, ST3E, ST3, SMC, ST4, DUS, RES
NODE.timing.bits-2.AISThreshold	SMC	PRS, STU, ST2, TNC, ST3E, ST3, SMC, ST4, DUS, RES
NODE.timing.bits-2.Coding	B8ZS	B8ZS, AMI when FacilityType DS1; AMI when FacilityType 64kHz+8kHz
NODE.timing.bits-2.CodingOut	B8ZS	B8ZS, AMI when FacilityTypeOut DS1; AMI when FacilityTypeOut 6MHz
NODE.timing.bits-2.FacilityType	DS1	DS1, 64kHz+8kHz
NODE.timing.bits-2.FacilityTypeOut	DS1	DS1, 6MHz
NODE.timing.bits-2.Framing	ESF	ESF, D4 when FacilityType DS1; N/A when FacilityType 64kHz+8kHz
NODE.timing.bits-2.FramingOut	ESF	ESF, D4 when FacilityTypeOut DS1; N/A when FacilityTypeOut 6MHz
NODE.timing.bits-2.LBO	0-133	0-133, 134-266, 267-399, 400-533, 534-655
NODE.timing.bits-2.State	IS	IS, OOS,DSBLD
NODE.timing.bits-2.StateOut	IS	IS, OOS,DSBLD
NODE.timing.general.Mode	External	External, Line, Mixed

Table C-20 Node Default Settings (continued)

Default Name	Default Value	Default Domain
NODE.timing.general.QualityOfRES	RES=DUS	PRS<RES, STU<RES<PRS, ST2<RES<STU, ST3<RES<ST2, SMC<RES<ST3, ST4<RES<SMC, RES<ST4, RES=DUS when SSMMMessageSet Generation 1; PRS<RES, STU<RES<PRS, ST2<RES<STU, TNC<RES<ST2, ST3E<RES<TNC, ST3<RES<ST3E, SMC<RES<ST3, ST4<RES<SMC, RES<ST4, RES=DUS when SSMMMessageSet Generation 2
NODE.timing.general.ReversionTime	5.0 (minutes)	0.5, 1.0, 1.5 .. 12.0
NODE.timing.general.Revertive	FALSE	TRUE, FALSE
NODE.timing.general.SSMMMessageSet	Generation 1	Generation 1, Generation 2

C.3.1 Time Zones

Table C-21 lists the time zones that apply for node time zone defaults. Time zones in the table are ordered by their relative relationships to Greenwich Mean Time (GMT), and the default values are displayed in the correct format for valid default input.

Table C-21 Time Zones

Time Zone (GMT +/- Hours)	Default Value
GMT-11:00	(GMT-11:00) Midway Islands, Samoa
GMT-10:00	(GMT-10:00) Hawaiian Islands, Tahiti
GMT-09:00	(GMT-09:00) Anchorage - Alaska
GMT-08:00	(GMT-08:00) Pacific Time (US & Canada), Tijuana
GMT-07:00	(GMT-07:00) Mountain Time (US & Canada)
GMT-07:00	(GMT-07:00) Phoenix - Arizona
GMT-06:00	(GMT-06:00) Central Time (US & Canada)
GMT-06:00	(GMT-06:00) Mexico City
GMT-06:00	(GMT-06:00) Costa Rica, Managua, San Salvador
GMT-06:00	(GMT-06:00) Saskatchewan

Table C-21 Time Zones (continued)

Time Zone (GMT +/- Hours)	Default Value
GMT-05:00	(GMT-05:00) Bogota, Lima, Quito
GMT-05:00	(GMT-05:00) Eastern Time (US & Canada)
GMT-05:00	(GMT-05:00) Havana
GMT-05:00	(GMT-05:00) Indiana (US)
GMT-04:00	(GMT-04:00) Asuncion
GMT-04:00	(GMT-04:00) Caracas, La Paz, San Juan
GMT-04:00	(GMT-04:00) Atlantic Time (Canada), Halifax, Saint John, Charlottetown
GMT-04:00	(GMT-04:00) Santiago
GMT-04:00	(GMT-04:00) Thule (Qaanaaq)
GMT-03:30	(GMT-03:30) St. John's - Newfoundland
GMT-03:00	(GMT-03:00) Brasilia, Rio de Janeiro, Sao Paulo
GMT-03:00	(GMT-03:00) Buenos Aires, Georgetown
GMT-03:00	(GMT-03:00) Godthab (Nuuk) - Greenland
GMT-02:00	(GMT-02:00) Mid-Atlantic
GMT-01:00	(GMT-01:00) Azores, Scoresbysund
GMT-01:00	(GMT-01:00) Praia - Cape Verde
GMT 00:00	(GMT 00:00) Casablanca, Reykjavik, Monrovia
GMT	(GMT) Greenwich Mean Time
GMT 00:00	(GMT 00:00) Dublin, Edinburgh, London, Lisbon
GMT+01:00	(GMT+01:00) Amsterdam, Berlin, Rome, Stockholm, Paris
GMT+01:00	(GMT+01:00) Belgrade, Bratislava, Budapest, Ljubljana, Prague
GMT+01:00	(GMT+01:00) Brussels, Copenhagen, Madrid, Vienna
GMT+01:00	(GMT+01:00) Sarajevo, Skopje, Sofija, Vilnius, Warsaw, Zagreb
GMT+01:00	(GMT+01:00) West Central Africa, Algiers, Lagos, Luanda
GMT+01:00	(GMT+01:00) Windhoek (Namibia)
GMT+02:00	(GMT+02:00) Al Jizah, Alexandria, Cairo
GMT+02:00	(GMT+02:00) Amman
GMT+02:00	(GMT+02:00) Athens, Bucharest, Istanbul
GMT+02:00	(GMT+02:00) Beirut
GMT+02:00	(GMT+02:00) Cape Town, Harare, Johannesburg, Pretoria
GMT+02:00	(GMT+02:00) Jerusalem
GMT+02:00	(GMT+02:00) Kaliningrad, Minsk
GMT+03:00	(GMT+03:00) Aden, Antananarivo, Khartoum, Nairobi
GMT+03:00	(GMT+03:00) Baghdad
GMT+03:00	(GMT+03:00) Kuwait, Riyadh
GMT+03:00	(GMT+03:00) Moscow, St. Petersburg, Novgorod

Table C-21 Time Zones (continued)

Time Zone (GMT +/- Hours)	Default Value
GMT+03:30	(GMT+03:30) Tehran
GMT+04:00	(GMT+04:00) Abu Dhabi, Mauritius, Muscat
GMT+04:00	(GMT+04:00) Aqtau, T'bilisi
GMT+04:00	(GMT+04:00) Baku
GMT+04:00	(GMT+04:00) Yerevan, Samara
GMT+04:30	(GMT+04:30) Kabul
GMT+05:00	(GMT+05:00) Chelyabinsk, Prem, Yekaterinburg, Ufa
GMT+05:00	(GMT+05:00) Islamabad, Karachi, Tashkent
GMT+05:30	(GMT+05:30) Calcutta, Mumbai, New Delhi, Chennai
GMT+05:45	(GMT+05:45) Kathmandu
GMT+06:00	(GMT+06:00) Almaty
GMT+06:00	(GMT+06:00) Colombo, Dhaka, Astana
GMT+06:00	(GMT+06:00) Novosibirsk, Omsk
GMT+06:30	(GMT+06:30) Cocos, Rangoon
GMT+07:00	(GMT+07:00) Bangkok, Hanoi, Jakarta
GMT+07:00	(GMT+07:00) Krasnoyarsk, Norilsk, Novokuznetsk
GMT+08:00	(GMT+08:00) Irkutsk, Ulaan Bataar
GMT+08:00	(GMT+08:00) Beijing, Shanghai, Hong Kong, Urumqi
GMT+08:00	(GMT+08:00) Perth
GMT+08:00	(GMT+08:00) Singapore, Manila, Taipei, Kuala Lumpur
GMT+09:00	(GMT+09:00) Chita, Yakutsk
GMT+09:00	(GMT+09:00) Osaka, Sapporo, Tokyo
GMT+09:00	(GMT+09:00) Palau, Pyongyang, Seoul
GMT+09:30	(GMT+09:30) Adelaide, Broken Hill
GMT+09:30	(GMT+09:30) Darwin
GMT+10:00	(GMT+10:00) Brisbane, Port Moresby, Guam
GMT+10:00	(GMT+10:00) Canberra, Melbourne, Sydney
GMT+10:00	(GMT+10:00) Hobart
GMT+10:00	(GMT+10:00) Khabarovsk, Vladivostok
GMT+10:30	(GMT+10:30) Lord Howe Island
GMT+11:00	(GMT+11:00) Honiara, Magadan, Solomon Islands
GMT+11:00	(GMT+11:00) Noumea - New Caledonia
GMT+11:30	(GMT+11:30) Kingston - Norfolk Island
GMT+12:00	(GMT+12:00) Andyra, Kamchatka
GMT+12:00	(GMT+12:00) Auckland, Wellington
GMT+12:00	(GMT+12:00) Marshall Islands, Eniwetok

Table C-21 Time Zones (continued)

Time Zone (GMT +/- Hours)	Default Value
GMT+12:00	(GMT+12:00) Suva - Fiji
GMT+12:45	(GMT+12:45) Chatham Island
GMT+13:00	(GMT+13:00) Nuku'alofa - Tonga
GMT+13:00	(GMT+13:00) Rawaki, Phoenix Islands
GMT+14:00	(GMT+14:00) Line Islands, Kiritimati - Kiribati

C.4 CTC Default Settings

Table C-22 on page C-86 lists the CTC-level default settings for the Cisco ONS 15454. Cisco provides the following user-configurable defaults for CTC:

- Automatic Routing—Set circuit creation with the Route Automatically check box selected by default.
- Create TL1-like—Set whether to create only TL1-like circuits; that is, instruct the node to create only cross-connects, allowing the resulting circuits to be in an upgradable state.
- Local domain creation and viewing—Set whether domains that you create and view persist globally (all CTC sessions), or only locally (within the current CTC session).
- Network Map—Set the default network map (which country's map is displayed in CTC network view).

Table C-22 CTC Default Settings

Default Name	Default Value	Default Domain
CTC.circuits.AutoRoute	TRUE	TRUE, FALSE
CTC.circuits.CreateLikeTL1	FALSE	TRUE, FALSE
CTC.network.LocalDomainCreationAndViewing	FALSE	TRUE, FALSE
CTC.network.Map	United States	-none-, Germany, Japan, Netherlands, South Korea, United Kingdom, United States



Numerics

- 1+1 optical port protection
 - creating linear ADMs [15](#)
 - description [13](#)
- 1:1 electrical card protection
 - cards supported [2](#)
 - description [2](#)
 - electrical interface assemblies [6](#)
 - example, shelf configurations by EIA type [9](#)
- 1:N electrical card protection
 - cards supported [3](#)
 - description [3](#)
 - DS3XM-12 portless [28](#)
 - electrical interface assemblies [6](#)
 - example, shelf configurations by EIA type [10](#)
 - miniBNC [22](#)
 - revertive switching [4](#)
 - rules [4](#)
- 15454_MRC-12 card. *See* MRC-12 card
- 802.1Q. *See* IEEE 802.1Q

A

- access control list [28](#)
- ACO [67](#)
- add-drop multiplexer. *See* linear ADM
- administrative states
 - automatic alarm suppression [3](#)
 - description [2](#)
- AEP
 - AIC-I compatibility [27](#)
 - cross-connect card compatibility [3](#)
 - description [55](#)
 - I-Temp [8](#)
 - power requirements [6](#)
 - software compatibility [3](#)
 - specifications [14](#)
- AIC card, software compatibility [3](#)
- AIC-I card
 - See also* AEP
 - See also* external alarms and controls
 - card-level LEDs [28](#)
 - cross-connect card compatibility [3](#)
 - description [27](#)
 - power monitoring [31](#)
 - power requirements [6](#)
 - software compatibility [3](#)
 - specifications [13](#)
 - temperature range [8](#)
- AIP
 - description [13](#)
 - location [11](#)
 - replacing [13](#)
- air filter [63](#)
- AISS-P parameter [5](#)
- AIMS [33](#)
- alarm expansion panel. *See* AEP
- alarm interface panel. *See* AIP
- alarm profiles
 - description [9](#)
 - applying [13](#)
 - comparing [11](#)
 - creating [10](#)
 - editing [12](#)
 - list by node [11](#)

- loading [11](#)
- modifying [10](#)
- saving [11](#)
- alarms
 - alarm suppressed by user [14](#)
 - alarm suppression with OOS,MT [3, 13, 3](#)
 - autodelete [4](#)
 - changing default severities. *See* alarm profiles
 - circuits affected [5](#)
 - deleting [4](#)
 - entries in session [7](#)
 - filter [4](#)
 - history [7](#)
 - log buffer capacities [9](#)
 - profiles. *See* alarm profiles
 - severities. *See* alarm profiles
 - synchronizing [4](#)
 - time zone [4](#)
 - traps. *See* SNMP
 - viewing [2](#)
- AMP Champ EIA
 - cable management [55](#)
 - card protection description [12](#)
 - connectors per side [5](#)
 - description [28](#)
 - pin assignments [30](#)
- applying alarm profiles [13](#)
- assigning Superuser privileges to Provisioning users [6](#)
- audit trail
 - capacities [8](#)
 - description [7](#)
- automatic protection switching
 - XC10G card switch matrix [19](#)
 - XCVT card switch matrix [15](#)
 - XC-VXC-10G card switch matrix [22](#)
- AEP connections [57](#)
- alarm contacts [66](#)
- AMP Champ [30](#)
- backplane pin field [64](#)
- BNC [18](#)
- LAN connections [67](#)
- MiniBNC [23](#)
- timing connections [67](#)
- TL1 craft interface connections [68](#)
- UBIC-H [35, 40, 42, 46, 48](#)
- backplane covers
 - description [10](#)
 - illustration [11](#)
 - lower backplane cover [11](#)
 - rear plastic cover [12](#)
- backplane ground posts [64](#)
- backplane IP address. *See* secure mode
- bandwidth
 - allocation and routing [27](#)
 - four-fiber BLSR capacity [9](#)
 - line percentage used by CE-Series Ethernet cards [40](#)
 - line percentage used by E-Series Ethernet cards [31](#)
 - line percentage used by G-Series Ethernet cards [33](#)
 - line percentage used by the FC_MR-4 card [47](#)
 - specifications [1](#)
 - two-fiber BLSR capacity [9](#)
- bay assembly [6](#)
- BBE-PM parameter [5](#)
- BBER-PM parameter [5](#)
- BBER-SM parameter [5](#)
- BBE-SM parameter [5](#)
- bidirectional line switched ring. *See* BLSR
- BIEC parameter [5](#)
- BITS
 - external node timing source [1](#)
 - input and output on the TCC2 card [8](#)
 - input and output on the TCC2P card [12](#)
 - interface specifications [3](#)
 - pin field assignments [67](#)

B

backplane connections

blades. *See* cards

BLSR

- bandwidth capacity [9](#)
- fiber connections [13](#)
- four-fiber [6](#)
- increasing the traffic speed [20](#)
- maximum node number [3](#)
- protection channel access circuits [21](#)
- ring switching [8](#)
- span switching [7](#)
- squelch tables [22](#)
- two-fiber description [3](#)
- two-fiber ring example [10](#)

BNC EIA

- description [17](#)
- card protection description [11](#)
- connectors per side [5](#)
- DS-3 card requirements [12](#)
- insertion and removal tool [19](#)

bridge and roll [36](#)

C

C2 byte [24](#)

cables

- CAT-5 (LAN) [52, 6, 7](#)
- coaxial. *See* coaxial cable
- DS-1 *See* DS-1 cables
- Ethernet [50](#)
- fiber management, standard [53](#)
- fiber management, tie-down bar [54](#)
- routing [52](#)
- UBIC-V. *See* UBIC-V cables

card protection

- See also* 1+1 optical port protection
- See also* 1+1 optimized optical protection
- See also* 1:1 electrical card protection
- See also* 1:N electrical card protection
- unprotected [14](#)

cards

- See also* cards indexed individually by name
- colors in node view [8](#)
- common-control card summary [1](#)
- preprovisioning [10](#)
- replacement [72](#)
- service state. *See* service states
- slot requirements [69](#)
- software compatibility [3](#)
- symbol and slot correspondence [70](#)

card view

- description [14](#)
- list of tabs [15](#)

CE-1000-4 card

- See also* Ethernet cards
- circuit types [28](#)
- compatible GBICs [32](#)
- cross-connect compatibility [31](#)
- description [28](#)
- LEDs [30](#)
- link capacity adjustment [34](#)
- port status [31](#)
- slot compatibility [31](#)
- specifications [46](#)
- SW-LCAS [29](#)
- VCAT differential delay [29](#)

CE-100T-8 card

- See also* Ethernet cards
- circuit types [26](#)
- cross-connect compatibility [28](#)
- description [25](#)
- LEDs [27](#)
- link capacity adjustment [34](#)
- port status [27](#)
- slot compatibility [28](#)
- specifications [47](#)
- VCAT circuits [33](#)

CGV parameter [5](#)

changing

- See also* modifying
- alarm severities [9](#)
- display of conditions [6](#)
- security policies [6](#)
- circuits
 - See also* STS
 - See also* VCAT circuits
 - See also* VT1.5 signals
 - attributes [2](#)
 - automatic routing [26](#)
 - autorange [2](#)
 - constraint-based routing [32](#)
 - exporting [3, 10](#)
 - filtering [3](#)
 - finding circuits with alarms [5](#)
 - manual routing detail [28](#)
 - maximize resources [15](#)
 - merging [42](#)
 - monitoring [19](#)
 - properties [2](#)
 - protection types [9](#)
 - reconfigured [43](#)
 - repairing [14](#)
 - service states [7](#)
 - statuses [6](#)
 - UDC circuits [42](#)
 - unidirectional with multiple drops [18](#)
 - viewing STS and VT matrices [15](#)
- Cisco IP tunnels [45](#)
- Cisco Transport Controller. *See* CTC
- CLNP [33](#)
- CLNS [33](#)
- coaxial cable
 - attenuation rates [15](#)
 - cable management [55](#)
 - description [37](#)
 - maximum distance [15](#)
- colors
 - cards in node view [8](#)
 - DCC colors in network view [13](#)
 - nodes in network view [13](#)
 - port colors and service states [9](#)
 - port state [11](#)
- common control cards
 - See* TCC2 card
 - See* TCC2P card
 - See* XC10G card
 - See* XCVT card
 - See* XC-VXC-10G card
- common fiber routing (VCAT) [33](#)
- comparing alarm profiles [11](#)
- computer requirements [4](#)
- conditions
 - changing display [6](#)
 - viewing [5](#)
- connecting to LANs using static routes [7](#)
- connectionless network protocol [33](#)
- connectionless network service [33](#)
- corporate LAN [7](#)
- cost [8](#)
- craft connection [7](#)
- creating
 - alarm profiles [10](#)
 - CTC user accounts [1](#)
 - linear ADMs [15](#)
- CSS parameter [5](#)
- CSS-P parameter [5](#)
- CTC
 - autodiscovery of newer software releases [3](#)
 - compatibility [73](#)
 - computer requirements [4](#)
 - concurrent session limit [3](#)
 - delivery methods [1](#)
 - exporting data [16](#)
 - printing data [16](#)
 - remote connection [7](#)
 - reverting to earlier load [18](#)
 - specifications [2](#)

- timing setup [1](#)
- C-Temp ranges [8](#)
- CVCP-PFE parameter [5](#)
- CVCP-P parameter [5](#)
- CV-PFE parameter [5](#)
- CV-P parameter [5](#)
- CVP-P parameter [5](#)
- CV-S parameter [6](#)
- CV-V parameter [6](#)

D

- database
 - See also* TCC2 card
 - See also* TCC2P card
 - description [17](#)
 - MAC address [13](#)
 - reverting [18](#)
- data cards. *See* Ethernet cards
- data communications channel. *See* DCC
- datagrams [4](#)
- DCC
 - AIC-I compatibility [32](#)
 - consolidating connections [13](#)
 - icon [14](#)
 - pin assignments [32](#)
 - termination on TCC2 card [7](#)
 - termination on TCC2P card [11](#)
 - viewing connections [13](#)
- DCC tunnels [16](#)
- DCG parameter [6](#)
- deep door kit [6](#)
- deleting
 - alarms [4](#)
- destination
 - host [4](#)
 - routing table [26](#)
- DHCP
 - default gateway and IP address assigned automatically [3](#)
 - description [7](#)
- documentation
 - audience [xli](#)
 - conventions in this book [xliv](#)
 - objectives [xli](#)
 - organization [xlii](#)
 - related to this book [xliv](#)
- domains, keeping node and secure IPs separate [18](#)
- drops
 - multiple drops [18](#)
 - secondary sources and drops [27](#)
 - service state requirements for drop ports [8](#)
- DS1/E1-56 card
 - See also* electrical cards
 - See also* UBIC-H EIA
 - See also* UBIC-V EIA
 - card-level LEDs [11](#)
 - description [9](#)
 - factory defaults [7](#)
 - port status [12](#)
 - slot compatibility [10](#)
 - specifications [18](#)
 - UBIC-H EIA J-labeling [35](#)
- DS1-14 card
 - See also* electrical cards
 - card-level LEDs [8](#)
 - cross-connect cards [8](#)
 - description [5](#)
 - EIA compatibility [16, 17](#)
 - EIA requirement [14](#)
 - factory defaults [4](#)
 - port status [9](#)
 - slot compatibility [6](#)
 - specifications [16](#)
 - traffic mapping [5](#)
- DS-1 cables
 - electrical interface adapter [38](#)

- overview [37](#)
- twisted-pair cable routing [55](#)
- twisted pair installation [37](#)
- See also* UBIC-H cables
- See also* UBIC-V cables
- DS1N-14 card
 - See also* electrical cards
 - card-level LEDs [8](#)
 - cross-connect cards [8](#)
 - description [5](#)
 - EIA compatibility [16, 17](#)
 - EIA requirement [14](#)
 - factory defaults [4](#)
 - port status [9](#)
 - slot compatibility [6](#)
 - specifications [16](#)
- DS3/EC1-48 card
 - See also* UBIC-V EIA
 - See also* electrical cards
 - See also* MiniBNC EIA
 - See also* UBIC-H EIA
 - card-level LEDs [17](#)
 - description [15](#)
 - EIA compatibility [16](#)
 - factory defaults [14](#)
 - J-labeling port assignments [24](#)
 - port status [18](#)
 - slot restrictions [15](#)
 - specifications [19](#)
 - UBIC-H EIA J-labeling [35](#)
- DS3-12 card
 - See also* electrical cards
 - BNC [18](#)
 - card-level LEDs [14](#)
 - description [12](#)
 - EIA compatibility [15, 16](#)
 - EIA requirement [14](#)
 - factory defaults [12, 13](#)
 - port status [15](#)
- slot compatibility [13](#)
- specifications [20](#)
- DS3-12E card
 - See also* electrical cards
 - card-level LEDs [23](#)
 - card protection [21](#)
 - description [20](#)
 - EIA compatibility [15, 16](#)
 - factory defaults [18](#)
 - port status [24](#)
 - slot compatibility [21](#)
 - specifications [22](#)
- DS3 CV-L parameter [5](#)
- DS3i-N-12 card
 - See also* electrical cards
 - card-level LEDs [20](#)
 - description [18](#)
 - EIA compatibility [15, 16](#)
 - factory defaults [20](#)
 - features [19](#)
 - port status [20](#)
 - slot compatibility [18](#)
 - specifications [21](#)
- DS3N-12 card
 - See also* electrical cards
 - card-level LEDs [14](#)
 - description [12](#)
 - EIA compatibility [15, 16](#)
 - EIA requirement [14](#)
 - factory defaults [12, 13](#)
 - port status [15](#)
 - slot compatibility [13](#)
 - specifications [20](#)
- DS3N-12E card
 - See also* electrical cards
 - card-level LEDs [23](#)
 - card protection [21](#)
 - description [20](#)
 - EIA compatibility [15, 16](#)

factory defaults [18](#)
 port-level LEDs [24](#)
 slot compatibility [21](#)
 specifications [22](#)

DS3XM-12 card

See also electrical cards

backplane configurations [26](#)
 card-level LEDs [30](#)
 description [26](#)
 EIA compatibility [15, 16](#)
 EIA requirement [14](#)
 factory defaults [25](#)
 ported mode [27](#)
 portless mode [27, 5, 15](#)
 port status [31](#)
 slot compatibility [27, 29](#)
 specifications [23](#)
 XC10G card support [21](#)
 XCVT card support [17](#)
 XC-VXC-10G card support [26](#)

DS3XM-6 card

See also electrical cards

card-level LEDs [25](#)
 description [24](#)
 EIA compatibility [16](#)
 EIA requirement [14](#)
 factory defaults [22](#)
 port status [26](#)
 slot compatibility [24](#)
 specifications [24](#)
 traffic mapping [25](#)
 XC10G card support [21](#)
 XCVT card support [17, 25](#)
 XC-VXC-10G card support [26](#)

DS-N cards. *See* electrical cards

dual GNEs [18](#)

dual IP addresses. *See* secure mode

DWDM

See also the *Cisco ONS 15454 DWDM Reference Manual*

GBICs [33](#)
 OC48 ELR/STM16 EH 100 GHz cards [26](#)
 OC48 ELR 200 GHz cards [28](#)

Dynamic Host Configuration Protocol. *See* DHCP

E

E1000-2 card

See also Ethernet cards

compatible GBICs [32](#)
 cross-connect compatibility [10](#)
 description [8](#)
 LEDs [10](#)
 port status [10](#)
 slot compatibility [10](#)
 specifications [46](#)

E1000-2-G card

See also Ethernet cards

compatible GBICs [32](#)
 cross-connect compatibility [13](#)
 description [11](#)
 LEDs [13](#)
 port status [13](#)
 slot compatibility [13](#)
 specifications [46](#)

E100T-12 card

See also Ethernet cards

cross-connect compatibility [5](#)
 description [3](#)
 LEDs [5](#)
 port status [5](#)
 slot compatibility [5](#)

E100T-G card

See also Ethernet cards

cross-connect compatibility [8](#)
 description [6](#)
 LEDs [7](#)

- port status [7](#)
- slot compatibility [7](#)
- specifications [45](#)
- E100-TX connector pinout [50](#)
- E-1 signal. *See* DS1/E1-56 card
- east port [13](#)
- EC-1
 - See* circuits
 - See* DS3/EC1-48 card
 - See* EC1-12 card
- EC1-12 card
 - See also* electrical cards
 - card-level LEDs [5](#)
 - cross-connect cards [5](#)
 - description [3](#)
 - EIA compatibility [15, 16](#)
 - EIA requirement [14](#)
 - factory defaults [29](#)
 - performance monitoring [12](#)
 - port status [5](#)
 - slot compatibility [4](#)
 - specifications [15](#)
- editing
 - alarm profiles [12](#)
- EIA
 - See also* AMP Champ EIA
 - See also* BNC EIA
 - See also* high-density BNC EIA
 - See also* MiniBNC EIA
 - See also* SMB EIA
 - See also* UBIC-H EIA
 - See also* UBIC-V EIA
 - card protection [5](#)
 - description [14](#)
 - installation overview [15](#)
 - replacement [37](#)
 - shelf assembly compatibility [15](#)
 - specifications [3](#)
- EIA/TIA-232 [68, 12](#)
- electrical cards
 - See also* 1:1 electrical card protection
 - See also* 1:N electrical card protection
 - See also* cards indexed individually by name
 - cross-connect card compatibility [4](#)
 - EIA requirement [2](#)
 - overview [2](#)
 - path trace capability [24](#)
 - performance monitoring [12](#)
 - ports, line rates, and connectors [70](#)
 - power requirements [7](#)
 - product names [9](#)
 - protection [1](#)
 - software compatibility [3](#)
 - temperature ranges [9](#)
- electrical codes [2](#)
- electrical interface assemblies. *See* EIA
- electromagnetic compatibility [37](#)
- enabling
 - ONS15454 gateway using Proxy ARP [4](#)
 - secure mode [20](#)
- ENE
 - definition [14](#)
 - filtering packets for the firewall [17](#)
 - firewall tunnel example [30](#)
 - GNE load balancing [18](#)
 - OSI/IP routing scenarios [52 to 56](#)
 - proxy tunnel and firewall tunnel requirement [29](#)
 - SOCKS proxy server scenario [12](#)
- enterprise LAN. *See* corporate LAN
- environmental specifications [3](#)
- errorless side switch
 - DS1/E1-56 card [10](#)
 - DS3/EC1-48 card [15](#)
 - DS3XM-12 card [26](#)
 - MRC-12 card [42](#)
 - XC-VXC-10G card [24](#)
- ESA-P parameter [6](#)
- ESB-P parameter [6](#)

- ESCP-PFE parameter [6](#)
- ESCP-P parameter [6](#)
- ESH [37](#)
- ES-IS protocol [36, 38](#)
- ES-L parameter [6](#)
- ES-NP parameter [6](#)
- ES-PFE parameter [6](#)
- ES-PM parameter [6](#)
- ES-P parameter [6](#)
- ESP-P parameter [6](#)
- ESR-PM parameter [6](#)
- ESR-SM parameter [6](#)
- ES-SM parameter [7](#)
- ES-S parameter [7](#)
- ES-V parameter [7](#)
- Ethernet
 - See also* Ethernet cards
 - cables [50](#)
 - RMON [16](#)
- Ethernet cards
 - See also* CE-1000-4 card
 - See also* CE-100T-8 card
 - See also* E1000-2 card
 - See also* E1000-2-G card
 - See also* E100T-12 card
 - See also* E100T-G card
 - See also* G1K-4 card
 - See also* ML1000-2 card
 - See also* ML100T-12 card
 - See also* ML100X-8 card
 - cross-connect card compatibility [5](#)
 - factory defaults [32](#)
 - overview [2](#)
 - path trace capability [24](#)
 - performance monitoring [29](#)
 - power requirements [8](#)
 - service disruption [14](#)
 - software compatibility [3](#)
 - specifications [45](#)
 - temperature range [10](#)
 - examples
 - 1:N protection configuration [2, 3](#)
 - basic LAN configuration [3](#)
 - BLSR bandwidth reuse [10](#)
 - BLSR ring switching [8](#)
 - BLSR span switching [7](#)
 - BLSR traffic rerouting following a fiber break [5](#)
 - common fiber routing on a VCAT circuit [33](#)
 - CTC and node on the same subnet [3](#)
 - CTC and nodes connected to a router [3](#)
 - dual roll on the same circuit [41](#)
 - dual roll with two circuits [41](#)
 - five-node, two-fiber BLSR [10](#)
 - foreign node connected to the DCC network [29](#)
 - four-fiber BLSR fiber connections [13](#)
 - four-fiber BLSRs [6](#)
 - four-shelf node (fiber-optic bus) [17](#)
 - GNE in a multivendor OSI network [52, 54, 56](#)
 - G-Series Ethernet cards with CWDM or DWDM GBICs [34](#)
 - IP-over-CLNS tunnel with a GNE endpoint [55](#)
 - manual TARP adjacencies [41](#)
 - nodes connected to a router with secure mode enabled [22](#)
 - nodes on the same subnet with secure mode enabled [21](#)
 - OSI/IP European network [59, 61](#)
 - OSI GNE with an IP connection to the DCN [57, 58](#)
 - path-protected mesh networks [15](#)
 - protocol flow in an IP-over-CLNS tunnel [45](#)
 - Proxy ARP [5](#)
 - remote node connected to an ENE Ethernet port [30](#)
 - roll from one circuit to another [40](#)
 - SOCKS proxy server implementation [14, 15](#)
 - split fiber routing on a CE-Series card VCAT circuit [34](#)
 - static routes [7](#)
 - TCA raised on electrical ports [2](#)
 - three-node linear ADM [15](#)
 - traffic pattern on a two-fiber BLSR [5](#)

- two-fiber BLSR [3](#)
- two-fiber BLSR fiber connections [13](#)
- unprotected configuration [14](#)
- exporting
 - circuits [3, 10](#)
 - CTC data [16](#)
- extended fiber clips [6](#)
- external alarms and controls
 - See also* AEP
 - See also* AIC-I card
 - alarm contact connections [66](#)
 - backplane connection location [11](#)
 - description [29, 14](#)
 - wire-wrap and pin connections [56](#)
- external firewalls [27](#)
- external switching commands [14](#)
- external timing [1](#)

F

- facility data link [18](#)
- factory defaults. *See* network element defaults
- fan-tray air filter. *See* air filter
- fan-tray assembly
 - description [61](#)
 - air filter [63](#)
 - fan failure [62](#)
 - fan speed [62](#)
- FC_MR-4 card
 - See also* VCAT circuits
 - applications [7](#)
 - compatible GBICs [8](#)
 - cross-connect compatibility [6, 4](#)
 - description [1](#)
 - factory defaults [31](#)
 - LEDs [3](#)
 - modes [4](#)
 - path trace capability [24](#)
 - performance monitoring [45](#)
 - ports, line rates, and connectors [71](#)
 - power requirements [8](#)
 - software link capacity adjustment (SW-LCAS) [34](#)
 - specifications [49](#)
 - temperature range [10](#)
 - VCAT circuits [33](#)
- FC-L parameter [7](#)
- FC-PFE parameter [7](#)
- FC-PM parameter [7](#)
- FC-P parameter [7](#)
- FC-SM parameter [7](#)
- ferrites [72](#)
- fiber capacity, per shelf [54](#)
- fiber guide [52](#)
- Fibre Channel card. *See* FC_MR-4 card
- filler card
 - description [60](#)
 - specifications [25](#)
- filtering
 - circuits [3](#)
 - firewall packets with ENE and GNE nodes [17](#)
- finding
 - circuits with alarms [5](#)
 - safety and warning information [1](#)
- firewall
 - external [27](#)
 - filtering packets [17](#)
 - firewall proxy with SNMP [16](#)
 - tunnel [29](#)
- flange [5](#)
- Force switch. *See* external switching commands
- four-fiber BLSR. *See* BLSR
- front door
 - equipment access [6](#)
 - ground strap [8](#)
 - label [9](#)
 - removing [9](#)
- FT-TD [43](#)
- fuse and alarm panel [2, 5](#)

FX interface [21](#)

G

G1000-4 card

description [14](#)

GBIC. *See* GBIC

LEDs [15](#)

port status [15](#)

slot compatibility [16](#)

STS-24c restriction [15](#)

G1K-4 card

See also Ethernet cards

compatible GBICs [32](#)

cross-connect compatibility [18](#)

description [16](#)

DWDM and CWDM GBIC compatibility [33](#)

LEDs [18](#)

port status [18](#)

slot compatibility [18](#)

specifications [47](#)

STS-24c restriction [17](#)

gateway

on routing table [26](#)

Proxy ARP-enabled [2, 4](#)

returning MAC address [4](#)

gateway network element. *See* GNE

gateway settings [13](#)

GBIC

overview [31](#)

card compatibility [32](#)

CE-1000-4 card [28](#)

compatible cards [50](#)

CWDM and DWDM [33](#)

description [32](#)

G1000-4 card [14](#)

G1K-4 card [16](#)

GNE

definition [14](#)

dual GNEs on the same subnet [18](#)

filtering packets for the firewall [17](#)

firewall configuration with SOCKS proxy server disabled [28](#)

firewall configuration with SOCKS proxy server enabled [28](#)

in a multivendor OSI network [52, 54, 56](#)

load balancing [18](#)

open GNE [29](#)

proxy tunnel and firewall tunnel requirement [29](#)

SOCKS proxy server scenario [12](#)

go-and-return path protection routing [20](#)

GRE tunnels [45](#)

grounding [63](#)

ground posts [64](#)

ground strap [8](#)

H

hex key [7](#)

high-density BNC EIA

card protection description [11](#)

connectors per side [5](#)

description [19](#)

insertion and removal tool [19](#)

high-density cards

See also DS1/E1-56 card

See also DS3/EC1-48 card

card protection by EIA type [8, 11](#)

card protection description [5](#)

high-density shelf

See also high-density cards

AIP [13](#)

EIA compatibility [16](#)

fan-tray assembly [62](#)

requirements [3](#)

sheet metal cover [11](#)

high-level data link control [32](#)

hop [8](#)

idle user timeout [6](#)

IEEE 802.1Q [4, 7, 12](#)

IETF [9](#)

increasing

- BLSR traffic speed [20](#)
- linear ADM traffic speed [20](#)
- path protection traffic speed [20](#)

insertion and removal tool

- BNC and high-density BNC [19](#)
- MiniBNC [27](#)

in-service topology upgrades [21](#)

installation

- See also* rack installation
- overview [2](#)
- reversible mounting bracket [4](#)

intermediate path performance monitoring. *See* IPPM

intermediate system hello [37](#)

Internet protocol. *See* IP

interoperability

- JRE compatibility [4](#)
- logging in [3](#)
- software and hardware matrix [73](#)

IOS parameter [7](#)

IP

- dual addresses. *See* secure mode
- dual IP addresses using secure mode [20](#)
- environments [1](#)
- keeping node IP and secure IP in separate domains [18](#)
- networking [1 to 23](#)
- provisioning two addresses [20](#)
- requirements [2](#)
- subnetting [2](#)

IP addressing scenarios

- CTC and nodes connected to router [3](#)
- CTC and nodes on same subnet [3](#)
- default gateway on CTC workstation [6](#)
- dual GNEs on a subnet [18](#)

- IP addressing with secure mode enabled [20](#)
- OSPF [10](#)
- Proxy ARP and gateway [4](#)
- static routes connecting to LANs [7](#)

IPC parameter [7](#)

IP-encapsulated tunnel [18](#)

IP-over-CLNS tunnels

- description [45](#)
- GNE as endpoint example [55](#)
- provisioning in CTC and Cisco IOS [46](#)
- tunneling from an ONS node to a router [48](#)
- tunneling from an ONS node to a router across an OSI DCN [49](#)
- tunneling from an ONS node to a vendor GRE [47](#)

IPPM [3](#)

ISH [37](#)

IS-IS protocol [36, 38](#)

ISO-DCC format [34](#)

I-Temp ranges [8](#)

J

J0 section trace [23](#)

J1/J2 bytes [23](#)

J1 path trace [20, 23](#)

J2 path trace [23](#)

JAR files [3](#)

Java [1](#)

J-labeling

- See* MiniBNC EIA
- See* UBIC-H EIA

JRE

- requirement [4](#)
- software compatibility [4](#)

jumper slack storage reels [52](#)

K

K byte [4](#)

L

label, front door [10](#)

LAN interface specifications [2](#)

LAN pin field [67](#)

LAN port

- TCC2 card [8](#)
- TCC2P card [12](#)

LAP-D [33](#)

laser warning [10](#)

LBCL-AVG parameter [7](#)

LBCL-MAX parameter [7](#)

LBCL-MIN parameter [7](#)

LCAS [26, 34](#)

LCD [62, 1](#)

LDB [41](#)

linear ADM

- See also* 1+1 optical card protection
- description [15](#)
- increasing the traffic speed [20](#)

line terminating cards [3](#)

line timing [1](#)

link capacity adjustment [34](#)

link consolidation

- description [13](#)
- icons [14](#)

link control protocol [32](#)

link-state packet [37](#)

loading alarm profiles [11](#)

LOFC parameter [7](#)

logging in, interoperability issues [3](#)

login node groups [11](#)

LOSS-L parameter [8](#)

lower backplane cover. *See* backplane covers

LSP [37](#)

M

MAC address

AIP [13](#)

- proxy ARP [4](#)
- repeater mode [20](#)
- retrieve table [4](#)
- secure mode [20](#)

Maintenance user [1](#)

management information base. *See* MIB

Manual switch. *See* external switching commands

maximum transmission unit [33](#)

merging circuits [42](#)

MIB [5](#)

Microsoft Internet Explorer [3](#)

MiniBNC EIA

- card protection description [12](#)
- connectors [21](#)
- connectors per side [5](#)
- description [20](#)
- insertion and removal tool [26](#)
- J-labeling [23](#)
- shelf compatibility [16](#)
- Trompetor requirement [14](#)

ML1000-2 card

- See also* Ethernet cards
- compatible SFPs [32](#)
- cross-connect compatibility [25](#)
- description [23](#)
- LEDs [25](#)
- port status [25](#)
- slot compatibility [25](#)
- specifications [48](#)

ML100T-12 card

- See also* Ethernet cards
- cross-connect compatibility [21](#)
- description [19](#)
- LEDs [20](#)
- port status [21](#)
- slot compatibility [21](#)
- specifications [47](#)

ML100X-8 card

See also Ethernet cards
 compatible SFPs [32](#)
 cross-connect compatibility [23](#)
 description [21](#)
 LEDs [23](#)
 port status [23](#)
 slot compatibility [23](#)
 specifications [48](#)
 modem interface [2](#)
 modifying
 See also changing
 alarm profiles [10](#)
 modules
 See cards
 See SFPs
 monitor circuits [19](#)
 monitoring
 circuits [19](#)
 power [31](#)
 traffic [23](#)
 mounting bracket, reversible [4](#)
 mounting the shelf assembly [5](#)
 MRC-12 card
 See also optical cards
 See also SFPs
 description [41](#)
 factory defaults [60](#)
 J0 section trace [23](#)
 LEDs [45](#)
 maximum bandwidth [43](#)
 performance monitoring [44](#)
 port and line rates [43](#)
 port status [46](#)
 SFP compatibility [50](#)
 specifications [42](#)
 topologies [41](#)
 multiple drops [18](#)

N

NE defaults. *See* network element defaults
 Netscape [3](#)
 network conversions [21](#)
 network element defaults
 description [1](#)
 card default tables [2](#)
 CTC defaults [86](#)
 node defaults [74](#)
 networks
 default configuration. *See* UPSR
 IP networking [1 to 23](#)
 open GNE [29](#)
 SONET topologies [1 to 17](#)
 third party, using server trails [43](#)
 timing example [2](#)
 network view
 description [11](#)
 DCC link states [13](#)
 link consolidation [13](#)
 logical network view [12](#)
 node status (icon colors) [13](#)
 security level by tabs [5](#)
 tabs list [12](#)
 NIOS parameter [8](#)
 node view
 card colors [8](#)
 creating users [1](#)
 port colors [9](#)
 security level by tab [2](#)
 tabs list [10](#)
 viewing popup information [10](#)
 NPJC-Pdet parameter [4](#)
 NPJC-PDET-P parameter [8](#)
 NPJC-Pgen parameter [4](#)
 NPJC-PGEN-P parameter [8](#)
 NSAP
 address fields [34](#)

- in virtual OSI routers [44](#)
- manually link to TIDs [42](#)
- TARP translation [39](#)
- used by CLNP to identify network devices [34](#)

O

OC12 IR/STM4 SH 1310-4 card

See also optical cards

- description [15](#)
- factory defaults [42](#)
- LEDs [17](#)
- port status [17](#)
- ring limitation [16](#)
- slot compatibility [16](#)
- specifications [31](#)

OC12 IR/STM4 SH 1310 card

See also optical cards

- description [9](#)
- factory defaults [39](#)
- LEDs [10](#)
- port status [11](#)
- slot compatibility [10](#)
- specifications [28](#)
- topologies [10](#)

OC12 LR/STM4 LH 1310 card

See also optical cards

- description [11](#)
- factory defaults [39](#)
- LEDs [12](#)
- port status [13](#)
- slot compatibility [12](#)
- specifications [29](#)
- topologies [12](#)

OC12 LR/STM4 LH 1550 card

See also optical cards

- description [13](#)
- factory defaults [39](#)
- LEDs [14](#)

- port status [15](#)
- slot compatibility [14](#)
- specifications [30](#)
- topologies [14](#)

OC192/STM64 Any Reach card. *See* OC192-XFP card

OC192 IR/STM64 SH 1550 card

See also optical cards

- description [31](#)
- factory defaults [50](#)
- LEDs [32](#)
- port status [33](#)
- slot compatibility [32](#)
- specifications [38](#)
- topologies [32](#)

OC192 LR/STM64 LH 1550 card

See also optical cards

- description [33](#)
- factory defaults [50](#)
- LEDs [38](#)
- port status [38](#)
- slot compatibility [37](#)
- specifications [39](#)
- topologies [37](#)

OC192 LR/STM64 LH ITU 15xx.xx card

See also optical cards

- description [38](#)
- factory defaults [50](#)
- LEDs [40](#)
- port status [41](#)
- slot compatibility [40](#)
- specifications [40](#)
- topologies [40](#)

OC192 SR/STM64 IO 1310 card

See also optical cards

- description [29](#)
- factory defaults [50](#)
- LEDs [30](#)
- port status [31](#)
- slot compatibility [30](#)

- specifications [37](#)
- topologies [30](#)
- OC192 SR1/STM64 IO Short Reach card. *See* OC192-XFP card
- OC192-XFP cards
 - See also* optical cards
 - See also* XFPs
 - description [46](#)
 - factory defaults [54](#)
 - J0 section trace [23](#)
 - LEDs [49](#)
 - port status [49](#)
 - slot compatibility [47](#)
 - specifications [43, 44](#)
 - XFP compatibility [50](#)
- OC3 IR/STM1 SH 1310-8 card
 - See also* optical cards
 - description [7](#)
 - factory defaults [35](#)
 - LEDs [9](#)
 - port status [9](#)
 - slot compatibility [8](#)
 - specifications [27](#)
 - topologies [8](#)
- OC3 IR 4/STM1 SH 1310 card
 - See also* optical cards
 - description [5](#)
 - factory defaults [32](#)
 - LEDs [7](#)
 - port status [7](#)
 - slot compatibility [6](#)
 - specifications [26](#)
 - topologies [6](#)
- OC-48 any-slot card
 - See* OC48 IR/STM16 SH AS 1310 card
 - See* OC48 LR/STM16 LH AS 1550 card
- OC48 ELR/STM16 EH 100 GHz cards
 - See also* optical cards
 - description [25](#)
- factory defaults [46](#)
- LEDs [27](#)
- port status [27](#)
- slot compatibility [26](#)
- specifications [35](#)
- topologies [26](#)
- OC48 ELR 200 GHz cards
 - See also* optical cards
 - description [27](#)
 - factory defaults [46](#)
 - LEDs [29](#)
 - port status [29](#)
 - slot compatibility [28](#)
 - specifications [36](#)
 - topologies [28](#)
- OC48 IR/STM16 SH AS 1310 card
 - See also* optical cards
 - description [21](#)
 - factory defaults [46](#)
 - LEDs [22](#)
 - port status [23](#)
 - slot compatibility [22](#)
 - specifications [33](#)
 - topologies [22](#)
- OC48 IR 1310 card
 - See also* optical cards
 - description [17](#)
 - factory defaults [46](#)
 - LEDs [18](#)
 - port status [19](#)
 - slot compatibility [18](#)
 - specifications [32](#)
 - topologies [18](#)
- OC48 LR/STM16 LH AS 1550 card
 - See also* optical cards
 - description [23](#)
 - factory defaults [46](#)
 - LEDs [24](#)
 - port status [25](#)

- slot compatibility [24](#)
 - specifications [34](#)
 - topologies [24](#)
 - OC48 LR 1550 card
 - See also* optical cards
 - description [19](#)
 - factory defaults [46](#)
 - LEDs [20](#)
 - port status [21](#)
 - slot compatibility [20](#)
 - specifications [33](#)
 - topologies [20](#)
 - OC-N cards. *See* optical cards
 - open GNE [29](#)
 - Open Shortest Path First. *See* OSPF
 - OPR-AVG parameter [8](#)
 - OPR-MAX parameter [8](#)
 - OPR-MIN parameter [8](#)
 - OPR parameter [8](#)
 - OPT-AVG parameter [8](#)
 - optical cards
 - See also* cards indexed individually by name
 - cross-connect card compatibility [4](#)
 - line terminating cards [3](#)
 - network element defaults [32 to 74](#)
 - overview [2](#)
 - path trace capability [24](#)
 - performance monitoring [42](#)
 - ports, line rates, and connectors [71](#)
 - power requirements [7](#)
 - product names [9](#)
 - protection. *See* 1+1 optical port protection *and* optimized 1+1 optical protection
 - software compatibility [4](#)
 - specifications [25](#)
 - temperature ranges [9](#)
 - timing [1](#)
 - upgrading to a higher rate while in-service [18](#)
 - optimized 1+1 optical protection [13](#)
 - OPT-MAX parameter [8](#)
 - OPT-MIN parameter [8](#)
 - optocoupler isolation [56](#)
 - OPT parameter [8](#)
 - OPWR-AVG parameter [8](#)
 - OPWR-MAX parameter [8](#)
 - OPWR-MIN parameter [8](#)
 - orderwire
 - description [30](#)
 - express [30](#)
 - local [30](#)
 - loop [31](#)
 - pin assignments (AIC-I card) [31](#)
 - OSI
 - connectionless network service [33](#)
 - mediation with TCP/IP [42](#)
 - networking scenarios [51](#)
 - overview [31](#)
 - protocol list [32](#)
 - provisioning in CTC [63](#)
 - routing [36](#)
 - virtual routers [43](#)
 - OSPF
 - advertising user-provisioned links [24](#)
 - alternative to static routes [7](#)
 - common scenarios [2](#)
 - definition [10](#)
 - in OSI routing scenarios [52](#)
-
- ## P
- passwords [6](#)
 - patch panel tool [19, 26](#)
 - path-protected mesh network. *See* PPMN
 - Path Protection
 - increasing the traffic speed [20](#)
 - path signal label [24](#)
 - path trace [23](#)
 - PCA [21](#)

- PCM [30](#)
- performance monitoring
 - DS1/E1 parameters [14](#)
 - DS1 and DS1N parameters [16](#)
 - DS3/EC1-48 parameters [27](#)
 - DS3-12E and DS3N-12E parameters [19](#)
 - DS3 and DS3N parameters [18](#)
 - DS3i-N-12 parameters [21](#)
 - DS3XM-12 parameters [25](#)
 - DS3XM-6 parameters [23](#)
 - EC1-12 card [12](#)
 - Ethernet cards [29](#)
 - FC_MR-4 card [45](#)
 - IPPM [3](#)
 - OC-N cards [42](#)
 - parameter definitions [4](#)
 - thresholds [1](#)
- pin assignments. *See* backplane connections
- ping [2](#)
- pinned hex key [7](#)
- PJCDIFF-P parameter [8](#)
- PJCS-PDET-P parameter [9](#)
- PJCS-PGEN-P parameter [9](#)
- pluggable device
 - See* pluggable port modules
 - See* SFPs
 - See* XFPs
- pluggable port modules [52, 20](#)
- pointer justification counts [4](#)
- point-to-point. *See* linear ADM
- point-to-point protocol [32](#)
- popup data [10](#)
- portless transmux interfaces. *See* DS3XM-12 card
- port service state. *See* service states
- power
 - fan-tray assembly [62](#)
 - monitoring [31](#)
 - specifications [3](#)
 - supply [63](#)
- PPJC-Pdet parameter [4](#)
- PPJC-PDET-P parameter [8](#)
- PPJC-Pgen parameter [4](#)
- PPJC-PGEN-P parameter [8](#)
- PPMN [15](#)
- preprovisioning
 - See also* provisioning cards [10](#)
- printing CTC data [16](#)
- processing TARP [40](#)
- protection switching
 - BLSR span switching [7](#)
 - nonrevertive 1+1 [13](#)
 - revertive [4](#)
 - ring switching [8](#)
- protocols
 - ES-IS [38](#)
 - IP [1](#)
 - IS-IS [38](#)
 - LAP-D (OSI) [33](#)
 - OSPF. *See* OSPF
 - point-to-point (OSI) [32](#)
 - Proxy ARP. *See* Proxy ARP
 - SNMP. *See* SNMP
 - SNTP [13](#)
 - SSM [3](#)
- provisionable patchcords
 - between OCH filter and OCH trunk port [24](#)
 - consolidate links [13](#)
 - definition [24](#)
 - optical port requirements [25](#)
- provisioning
 - See also* preprovisioning
 - IP-over-CLNS tunnels [46](#)
 - security policies [6](#)
 - two IP addresses [20](#)
- Provisioning user [1](#)
- Proxy ARP
 - common scenarios [2](#)

- enabling an ONS 15454 gateway [4](#)
- use with static routes [5](#)
- proxy tunnel [29](#)
- PSC parameter [9](#)
- PSC-R parameter [9](#)
- PSC-S parameter [9](#)
- PSC-W parameter [9](#)
- PSD parameter [9](#)
- PSD-R parameter [9](#)
- PSD-S parameter [10](#)
- PST [1](#)
- PSTQ [1](#)

R

- rack installation
 - overview [3](#)
 - bay assembly [6](#)
 - multiple nodes [5](#)
 - single node [5](#)
- rack size [2](#)
- RADIUS authentication [8](#)
- rear cover. *See* backplane covers
- reconfigured circuits [43](#)
- remote network monitoring. *See* RMON
- removing the front door [9](#)
- repairing circuits [14](#)
- repeater mode [18, 2, 20, 21](#)
- replacing
 - AIP [13](#)
 - cards [72](#)
 - EIAs [37](#)
- resetting the active TCC2/TCC2P card [14](#)
- Retrieve user [1](#)
- reverting software [18](#)
- revertive switching. *See* protection switching
- RG-179 cable. *See* coaxial cable
- RG59 (735A) cable. *See* coaxial cable
- RIB [36](#)
- rings
 - See also* BLSR
 - maximum per node [1](#)
 - virtual [16](#)
- RJ-11
 - orderwire pin assignments [31](#)
 - UDC pin assignments [31](#)
- RJ-45
 - See also* TCC2 card *or* TCC2P card
 - connectors on cards [71](#)
 - DCCs on AIC-I card [32](#)
 - LAN pin assignments [68](#)
 - PC connection [6](#)
 - Superuser access [6](#)
 - TCC2 port description [8](#)
 - TCC2P port description [12](#)
- RMON [16 to 23](#)
- roll
 - automatic [38](#)
 - dual [39](#)
 - manual [38](#)
 - one cross-connection [39](#)
 - path [38](#)
 - protected circuits [42](#)
 - restrictions on two-circuit rolls [41](#)
 - single [39](#)
 - status [38](#)
 - two cross-connections [39](#)
 - unprotected circuits [42](#)
 - window [37](#)
- routing
 - bandwidth [27](#)
 - circuits, constraint-based [32](#)
 - circuits automatically [26](#)
 - circuits manually [28](#)
 - common fiber on VCAT circuits [33](#)
 - go-and-return path protection [20](#)
 - OSI [36](#)
 - split fiber on VCAT circuits [34](#)

traffic [26](#)
 VCAT members [33](#)
 routing information base [36](#)
 routing table [26](#)
 RS-232. *See* EIA/TIA-232

S

safety, finding information about [1](#)
 SAPI [33](#)
 SASCP-P parameter [10](#)
 SASP parameter [10](#)
 SASP-P parameter [10](#)
 saving alarm profiles [11](#)
 SCSI connectors
 See UBIC-H EIA
 See UBIC-V EIA
 SDCC. *See* DCC
 secondary sources [27](#)
 secure mode
 enabling [20](#)
 examples [2](#)
 locked and unlocked behavior [23](#)
 secure shell [6](#)
 security
 default password [1](#)
 idle user timeout [6](#)
 levels [1](#)
 policies [6](#)
 RADIUS [8](#)
 secure (locked) mode [20](#)
 tasks per level [2,5](#)
 viewing level [8](#)
 SEF-S parameter [10](#)
 server trails
 description [43](#)
 link icon [14](#)
 Service Access Point Identifier [33](#)
 service states

See also administrative states
 card service state location [14](#)
 card service state transitions [3](#)
 cross-connect state transitions [5](#)
 description [1](#)
 port colors [9](#)
 port state transitions [5](#)
 SESCO-PFE parameter [10](#)
 SESCO-P parameter [10](#)
 SES-L parameter [10](#)
 SES-PFE parameter [10](#)
 SES-PM parameter [10](#)
 SES-P parameter [10](#)
 SESP-P parameter [10](#)
 SESR-PM parameter [11](#)
 SESR-SM parameter [11](#)
 SES-SM parameter [10](#)
 SES-S parameter [10](#)
 SES-V parameter [11](#)
 SFPs
 compatibility by card [49,32](#)
 description [50,35](#)
 Ethernet cards [31](#)
 optical cards [49](#)
 specifications [4](#)
 shared secrets [9](#)
 shelf assembly
 description [3](#)
 bay assembly [6](#)
 dimensions [4,33,4](#)
 environmental specifications [3](#)
 fiber capacity [54](#)
 four-node configuration [17](#)
 mounting [5](#)
 Simple Network Management Protocol. *See* SNMP
 SMB EIA
 balun requirement [38](#)
 card protection description [12](#)
 connectors per side [5](#)

- description [27](#)
- DS-3 card requirements [12](#)
- twisted pair wire-wrap requirement [37](#)
- SNMP
 - community names [16](#)
 - components [2](#)
 - external interfaces [4](#)
 - message types [4](#)
 - MIBs [5](#)
 - overview [1](#)
 - RMON [16](#)
 - trap content [8](#)
 - version support [4](#)
- soak time [8](#)
- SOCKS proxy server
 - common scenarios [2](#)
 - definition [12](#)
 - firewall with SOCKS enabled [28](#)
 - open GNE network [29](#)
 - proxy and firewall tunnels [29](#)
- software
 - See also* CTC
 - autodiscovery of newer releases [3](#)
 - card compatibility [3](#)
 - delivery methods [1](#)
 - reverting [18](#)
- SONET
 - K1, K2, and K3 bytes [4](#)
 - path signal label [24](#)
 - synchronization status messaging [3](#)
 - timing parameters [1](#)
 - topologies [1](#)
- spacers [12](#)
- span upgrades [20](#)
- SPE. *See* synchronous payload envelope
- split fiber routing (VCAT) [33](#)
- squelch table
 - STS [22](#)
 - VT [22](#)
- SSH [6](#)
- SSM
 - description [3](#)
 - message set [3](#)
- SST [1](#)
- ST3 clock [1](#)
- state
 - See* administrative states
 - See* circuits, states
 - See* service states
- static routes
 - common scenario [2](#)
 - connecting to LANs [7](#)
- storage access networking cards. *See* FC_MR-4 card
- string [23,24](#)
- STS
 - CTC matrices [15](#)
 - ML-Series card capacity [20,22](#)
 - squelch table [22](#)
 - STS-24c restriction with G1K-4 card [17](#)
 - time slot assignments [4](#)
 - XC10G switch matrix [19](#)
 - XCVT switch matrix [15](#)
 - XC-VXC-10G switch matrix [22](#)
- subnet
 - CTC and nodes on different subnets [3](#)
 - CTC and nodes on same subnet [3](#)
 - multiple subnets on the network [6](#)
 - using static routes [7](#)
 - with Proxy ARP [4,5](#)
- subnet mask
 - 24-bit [26](#)
 - 32-bit [27](#)
 - access to nodes [8](#)
 - destination host or network [26](#)
- Superuser
 - assigning Superuser privileges to Provisioning users [6](#)
 - changing security policies [6](#)
 - description [1](#)

SW-LCAS 34

synchronization status messaging. *See* SSM

synchronizing alarms 4

synchronous payload envelope 4

T

tabs

card view 15

network view 12

node view 10

overview 7

TARP

data cache 40

descripton 39

loop detection buffer 41

manual adjacencies 41

PDU fields 39

PDU types 39

processing 40

TCA

definition 2

IPPM paths 3

list of ports that report TX and RX direction 2

RX and TX on electrical ports 2

TCC+ card, software compatibility 3

TCC2 card

description 6

card-level LEDs 8

craft interface 2

cross-connect card compatibility 3

database description 17

DCC termination 7

EIA/TIA-232 port 68

fan speed control 62

interface ports 8

LAN port 67, 7

network-level LEDs 9

node database 8

power requirements 6

redundant installation process 8

repeater mode 20

reset service disruption 14

slot compatibility 8

soft reset 17

software 1

software compatibility 3

specifications 10

temperature ranges 8

TCC2P card

description 10

behavior when secure mode is enabled 21

card-level LEDs 13

craft interface 2

cross-connect card compatibility 3

database description 17

DCC termination 11

EIA/TIA-232 port 68

enhancements over TCC2 10

fan speed control 62

functionality 11

LAN interface cable 10

LAN port 67, 7

network-level LEDs 13

node database 12

power requirements 6

redundant installation process 12

repeater mode 2, 20

reset service disruption 14

secure (locked) mode 20

slot compatibility 12

soft reset 17

software 1

software compatibility 3

specifications 11

system timing 12

temperature ranges 8

TCP/IP

- and OSI mediation [42](#)
- DCN communication [31](#)
- TCC2P access [12](#)
- TDM [12](#)
- TEI [33](#)
- Telcordia
 - alarm severities [1](#)
 - performance monitoring [1](#)
 - standard racks [3](#)
 - VT mapping standards [16, 20, 25](#)
- temperature ranges [8](#)
- Terminal Endpoint Identifier [33](#)
- third-party equipment [2, 16](#)
- tie-down bar [54](#)
- time slot assignments [4](#)
- timing
 - BITS pin fields [67](#)
 - parameters [1](#)
 - report [1](#)
 - specifications [3](#)
- TL1
 - AID in CTC [8](#)
 - command reference [3](#)
 - connection requirements [7](#)
 - craft interface connection [68](#)
 - interface specifications [2](#)
- topology host, VLANs [43](#)
- topology upgrade
 - in-service topology upgrades, description [21](#)
 - node addition or removal [23](#)
 - Path Protection to two-fiber BLSR [23](#)
 - point-to-point or linear ADM to two-fiber BLSR [22](#)
 - two-fiber to four-fiber BLSR [23](#)
 - unprotected point-to-point or linear ADM to Path Protection [22](#)
- traffic monitoring [23](#)
- traffic routing [26](#)
- transmission timers [33](#)
- transmux card

- See* DS3XM-12 card
- See* DS3XM-6 card
- T-TD [42](#)
- tunnels
 - Cisco IP tunnels [45](#)
 - DCC tunnels [16](#)
 - GRE tunnels [45](#)
 - IP-encapsulated tunnels [18](#)
 - IP-over CLNS tunnels [45](#)
- twisted pair wire-wrap [37](#)
- two-fiber BLSR. *See* BLSR

U

- UASCP-PFE parameter [11](#)
- UASCP-P parameter [11](#)
- UAS-L parameter [11](#)
- UAS-PFE parameter [11](#)
- UAS-PM parameter [11](#)
- UAS-P parameter [11](#)
- UASP-P parameter [12](#)
- UAS-SM parameter [12](#)
- UAS-V parameter [12](#)
- UBIC-H cables
 - connector pins [45](#)
 - description [44](#)
 - DS-1 pin assignments [40, 46](#)
 - DS-3/EC-1 pin assignments [42, 48](#)
- UBIC-H EIA
 - card protection description [12](#)
 - connector labeling [34](#)
 - connectors per side [5](#)
 - description [33](#)
 - J labeling [34](#)
 - shelf assembly compatibility [17](#)
 - See also* UBIC-H cables
- UBIC-V cables
 - connector pins [39, 51, 52](#)
 - description [39](#)

UBIC-V EIA

- card protection description [12](#)
- connectors per side [5](#)
- description [32](#)
- SCSI connectors [14](#)
- shelf assembly compatibility [17](#)
- slot designations [32](#)
- See also* UBIC-V cables

UDC [31](#)UITS [33](#)UNC-WORDS parameter [12](#)

UNIX

- software location [3](#)
- workstation requirements [4](#)

upgrading

- See* span upgrades
- See* topology upgrade

UPSR

- go-and-return routing [20](#)
- open-ended circuits [20](#)

user. *See* security

user data channel [31, 42](#)

user-defined alarms. *See* external alarms and controls

V

VAP

- definition [23](#)
- merged circuits [42](#)

VCAT circuits

- description [33](#)
- add or delete member [35](#)
- circuit states [33](#)
- common fiber routing [33](#)
- differential delay on the CE-1000-4 [29](#)
- differential delay on the FC_MR-4 card [2](#)
- in-service topology upgrade support [21](#)
- member routing [33](#)
- non-LCAS VCAT circuits [35](#)

server trail support [44](#)

sizes [3](#)

split routing [33](#)

supported rates [35](#)

viewing

- alarms [2](#)
- conditions [5](#)
- DCC connections [13](#)
- node view popup information [10](#)
- security level [8](#)
- STS and VT matrices [15](#)
- topology hosts and provisioned VLANs [43](#)

views

- See* card view
- See* network view
- See* node view

virtual links. *See* provisionable patchcords

virtual rings [16](#)

VLAN

- IEEE 802.1Q tag [12](#)
- IEEE 802.1Q VLAN tag [9](#)
- merged circuits [42](#)
- viewing topology hosts and provisioned VLANs [43](#)

VPC parameter [12](#)

VT1.5 signals

- BLSR example [14](#)
- cross-connect card bandwidth [12](#)
- CTC matrices [15](#)
- DS-1 transport [5, 8](#)
- DS3XM-12 card [26](#)
- DS3XM-6 card [24](#)
- squelch table [22](#)
- XC10G card [19](#)
- XCVT card [15](#)
- XC-VXC-10G card [23](#)

VT2 signals [23](#)

VT mapping [16, 20, 25](#)

W
WAN [2](#)

warnings

definition [xlv](#)finding information about [I](#)west port [13](#)

X

XC10G card

bandwidth [12](#)card-level LEDs [21](#)description [18](#)functionality [19](#)hardware compatibility [75](#)power requirements [6](#)slot compatibility [19](#)software compatibility [3](#)specifications [12](#)temperature range [8](#)VT mapping [20](#)

XC card

hardware compatibility [73](#)software compatibility [3](#)

XCVT card

bandwidth [12](#)card-level LEDs [17](#)compatibility limitations [22](#)cross-connect matrix [16](#)description [14](#)functionality [15](#)hardware compatibility [73](#)power requirements [6](#)slot compatibility [16](#)software compatibility [3](#)specifications [12](#)temperature range [8](#)VT mapping [16](#)

XC-VXC-10G card

bandwidth [12](#)card-level LEDs [26](#)cross-connect matrix [25](#)description [22](#)errorless side switch [24](#)hardware compatibility [75](#)power requirements [6](#)slot compatibility [24](#)software compatibility [3](#)specifications [13](#)STS and VT capacity [23](#)temperature range [8](#)VT mapping [25](#)

XFPs

compatibility by card [49](#)description [51](#)span length [48](#)specifications [4](#)

