



Turn Up Network



Note

The terms "Unidirectional Path Switched Ring" and "UPSR" may appear in Cisco literature. These terms do not refer to using Cisco ONS 15xxx products in a unidirectional path switched ring configuration. Rather, these terms, as well as "Path Protected Mesh Network" and "PPMN," refer generally to Cisco's path protection feature, which may be used in any topological network configuration. Cisco does not recommend using its path protection feature in any particular topological network configuration.

This chapter explains how to turn up and test Cisco ONS 15600s in point-to-point networks, bidirectional line switched rings (BLSRs), path protection configurations, and dual-ring interconnects (DRIs).

Before You Begin

This section lists the chapter procedures (NTPs). Turn to a procedure for applicable tasks (DLPs).

1. [NTP-E32 Verify Node Turn-Up, page 5-2](#)—Complete this procedure before beginning network turn-up.
2. [NTP-E33 Provision a Point-to-Point Connection, page 5-3](#)—Complete this procedure as needed to connect two ONS 15600s in a point-to-point network.
3. [NTP-E34 Point-to-Point Network Acceptance Test, page 5-4](#)—Complete this procedure after you provision the point-to-point network.
4. [NTP-E163 Provision BLSR Nodes, page 5-6](#)—Complete this procedure to provision ONS 15600s in a two-fiber BLSR.
5. [NTP-E164 Create a BLSR, page 5-9](#)—Complete this procedure after provisioning the BLSR nodes.
6. [NTP-E89 Two-Fiber BLSR Acceptance Test, page 5-10](#)—Complete this procedure after you provision a two-fiber BLSR.
7. [NTP-E165 Four-Fiber BLSR Acceptance Test, page 5-12](#)—Complete this procedure after you provision a four-fiber BLSR.
8. [NTP-E170 Provision a Traditional BLSR Dual-Ring Interconnect, page 5-14](#)—As needed, complete this procedure after you provision a BLSR.
9. [NTP-E171 Provision an Integrated BLSR Dual-Ring Interconnect, page 5-16](#)—As needed, complete this procedure after you provision a BLSR.
10. [NTP-E35 Provision Path Protection Nodes, page 5-17](#)—Complete this procedure as needed to create a path protection.

11. [NTP-E36 Path Protection Acceptance Test, page 5-19](#)—Complete this procedure after you provision the path protection.
12. [NTP-E137 Provision a Traditional Path Protection Dual-Ring Interconnect, page 5-21](#)—As needed, complete this procedure after you provision a path protection.
13. [NTP-E138 Provision an Integrated Path Protection Dual-Ring Interconnect, page 5-23](#)—As needed, complete this procedure after you provision a path protection.
14. [NTP-E172 Provision a Traditional BLSR/Path Protection Dual-Ring Interconnect, page 5-24](#)—As needed, complete this procedure after you provision a path protection and BLSR.
15. [NTP-E173 Provision an Integrated BLSR/Path Protection Dual-Ring Interconnect, page 5-27](#)—As needed, complete this procedure after you provision a path protection and BLSR.
16. [NTP-E141 Provision an Open-Ended Path Protection, page 5-29](#)—As needed, complete this procedure after you provision a path protection.
17. [NTP-E142 Open-Ended Path Protection Acceptance Test, page 5-31](#)—As needed, complete this procedure after you provision an open-ended path protection.
18. [NTP-E86 Create a Logical Network Map, page 5-33](#)—Complete as needed.

NTP-E32 Verify Node Turn-Up

Purpose	This procedure verifies that each ONS 15600 is ready for network turn-up.
Tools/Equipment	None
Prerequisite Procedures	Chapter 4, “Turn Up Node”
Required/As Needed	Required
Onsite/Remote	Onsite
Security Level	Provisioning or higher

-
- Step 1** Complete the [“DLP-E26 Log into CTC” task on page 16-39](#). If you are already logged in, continue with Step 2.
- Step 2** Complete the [“DLP-E161 Single Shelf Control Card Switch Test” task on page 17-48](#).
- Step 3** From the View menu, choose **Go To Network View**.
- Step 4** Click the **Alarms** tab. Complete the following steps:
- a. Verify that the alarm filter is not on. See the [“DLP-E157 Disable Alarm Filtering” task on page 17-46](#) for instructions.
 - b. Verify that no critical or major alarms appear on the network. If alarms appear, investigate and resolve them before continuing. Refer to the *Cisco ONS 15600 Troubleshooting Guide* for procedures.
- Step 5** From the View menu, choose **Go To Previous View** to return to node view.
- Step 6** Verify that the SW Version and Defaults that appear in the node view status area match the software version and NE defaults shown in your site plan. If either are not correct, complete the following procedures as needed:
- If the software is not the correct version, install the correct version from the ONS 15600 software CD. Upgrade procedures are located on the CD. Follow the upgrade procedures appropriate to the software currently installed on the node.

- If the node defaults are not correct, refer to the “Network Element Defaults” appendix in the *Cisco ONS 15600 Reference Manual*.
- Step 7** Click the **Provisioning > General** tabs. Verify that all general node information settings match the settings of your site plan. If not, see the “[NTP-E22 Set Up Date, Time, and Contact Information](#)” procedure on page 4-4.
- Step 8** Click the **Provisioning > Timing** tabs. Verify that timing settings match the settings of your site plan. If not, see the “[NTP-E96 Change Node Management Information](#)” procedure on page 11-2.
- Step 9** Click the **Provisioning > Network** tabs. Ensure that the IP settings and other CTC network access information is correct. If not, see the “[NTP-E59 Change CTC Network Access](#)” procedure on page 11-2.
- Step 10** Click the **Provisioning > Protection** tabs. Verify that all protection groups have been created according to your site plan. If not, see the “[NTP-E25 Create a 1+1 Protection Group](#)” procedure on page 4-7 or the “[NTP-E61 Modify or Delete Optical 1+1 Port Protection Settings](#)” procedure on page 11-4.
- Step 11** Click the **Provisioning > Security** tabs. Verify that all users have been created and their security levels match the settings indicated by your site plan. If not, see the “[NTP-E63 Modify Users and Change Security](#)” procedure on page 11-6.
- Step 12** If Simple Network Management Protocol (SNMP) is provisioned on the shelf, click the **Provisioning > SNMP** tabs. Verify that all SNMP settings match the settings of your site plan. If not, see the “[NTP-E64 Change SNMP Settings](#)” procedure on page 11-6.
- Step 13** Provision the network using the applicable procedure shown in the “[Before You Begin](#)” section on page 5-1.
- Stop. You have completed this procedure.**
-

NTP-E33 Provision a Point-to-Point Connection

Purpose	This procedure provisions 1+1 protected spans between two ONS 15600 nodes, an ONS 15600 and an ONS 15454 node, or an ONS 15600 and an ONS 15327 node.
Tools/Equipment	PC or UNIX workstation set up for ONS 15600 access
Prerequisite Procedures	NTP-E32 Verify Node Turn-Up , page 5-2
Required/As Needed	Required
Onsite/Remote	Onsite
Security Level	Provisioning or higher

- Step 1** Attach fiber from working port to working port and from protect port to protect port on the two nodes that you will provision for a point-to-point configuration.
- Step 2** Complete the “[DLP-E26 Log into CTC](#)” task on page 16-39 at either node. The node view appears. If you are already logged in, continue with [Step 3](#).
- Step 3** Click the **Provisioning > Protection** tabs. Verify that 1+1 protection is created for the OC-N ports. Complete the “[NTP-E25 Create a 1+1 Protection Group](#)” procedure on page 4-7 if protection has not been created.



Note The switching direction (unidirectional versus bidirectional) and the revertive setting (nonrevertive versus revertive) must be the same at each end.

- Step 4** Repeat Steps 2 and 3 for the second node.
- Step 5** Verify that the working and protect ports in the 1+1 protection groups correspond to the physical fiber connections between the nodes; that is, verify that the working port in one node connects to the working port in the other node and that the protect port in one node connects to the protect port in the other node.
- Step 6** Complete the “[DLP-E114 Provision Section DCC Terminations](#)” task on page 17-14 for the working OC-N port on both point-to-point nodes. Alternatively, if additional bandwidth is needed for CTC management, complete the “[DLP-E189 Provision Line DCC Terminations](#)” task on page 17-68.



Note Data communications channel (DCC) terminations are not provisioned on the protect port.



Note If point-to-point nodes are not connected to a LAN, you will need to create the DCC terminations using a direct (craft) connection to the node. Remote provisioning is possible only after all nodes in the network have DCC terminations provisioned to in-service OC-N ports.

- Step 7** As needed, complete the “[DLP-E190 Provision a Proxy Tunnel](#)” task on page 17-70.
- Step 8** As needed, complete the “[DLP-E191 Provision a Firewall Tunnel](#)” task on page 17-71.
- Step 9** As needed, complete the “[DLP-E194 Create a Provisionable Patchcord](#)” task on page 17-72.
- Step 10** Verify that timing is set up at both point-to-point nodes. If not, complete the “[NTP-E24 Set Up Timing](#)” procedure on page 4-6. If a node uses line timing, set the working OC-N as the timing source.
- Step 11** Complete the “[DLP-E115 Change the Service State for a Port](#)” task on page 17-16 to put the protect OC-N ports in service at both nodes.
- Step 12** Complete the “[NTP-E34 Point-to-Point Network Acceptance Test](#)” procedure on page 5-4.

Stop. You have completed this procedure.

NTP-E34 Point-to-Point Network Acceptance Test

Purpose	This procedure tests a point-to-point ONS 15600 network.
Tools/Equipment	Optical power meter and fiber jumpers OC-N SONET/SDH test set Fiber cables An additional OC-N port depending on the span bandwidth at each node. These ports are required for test set connectivity. These are the ports you use as the circuit source and destination.
Prerequisite Procedures	NTP-E33 Provision a Point-to-Point Connection , page 5-3
Required/As Needed	Required

Onsite/Remote	Onsite
Security Level	Provisioning or higher

-
- Step 1** Complete the “[DLP-E26 Log into CTC](#)” task on page 16-39 at one of the point-to-point nodes. The node view appears. If you are already logged in, continue with [Step 2](#).
- Step 2** From the View menu, choose **Go To Network View**.
- Step 3** Click the **Alarms** tab. Complete the following steps:
- Verify that the alarm filter is not on. See the “[DLP-E157 Disable Alarm Filtering](#)” task on page 17-46 for instructions.
 - Verify that no unexplained alarms appear on the network. If unexplained alarms appear, resolve them before continuing. Refer to the *Cisco ONS 15600 Troubleshooting Guide*.
 - Complete the “[DLP-E265 Export CTC Data](#)” task on page 18-84 to export alarm information.
- Step 4** Click the **Conditions** tab. Complete the following steps:
- Verify that no unexplained conditions appear on the network. If unexplained conditions appear, resolve them before continuing. Refer to the *Cisco ONS 15600 Troubleshooting Guide*.
 - Complete the “[DLP-E265 Export CTC Data](#)” task on page 18-84 to export condition data.
- Step 5** On the network map, double-click the node that you logged into in [Step 1](#).
- Step 6** Create a test circuit from the login node to the other point-to-point node. Complete the “[NTP-E160 Create an Automatically Routed Optical Circuit](#)” procedure on page 6-4. When you set the circuit state, choose **IS** and check the **Apply to drop ports** check box. Choose one of the following options:
- For an OC-3 span, create an STS3c test circuit.
 - For an OC-12 span, create an STS12c test circuit.
 - For an OC-48 span, create an STS48c test circuit.
 - For an OC-192 span, create an STS192c test circuit. If an OC-192 test set is not available, create an OC-48 test circuit across an OC-192 span.
- Step 7** Configure the test set for the test circuit type you created. For information about configuring your test set, consult your test set user guide.
- Step 8** Verify the integrity of all patch cables that will be used in this test by connecting one end to the test set transmit (Tx) connector the other to the test set receive (Rx) connector. Use appropriate attenuation on the test set receive connector; for more information, refer to the test set manual. If the test set does not run error-free, check the cable for damage and check the test set to make sure it is set up correctly before going to [Step 9](#).
- Step 9** Create a physical loopback at the circuit destination port. To do so, attach one end of a patch cable to the destination port’s Tx connector; attach the other end to the port’s Rx connector.
-  **Note** Use an appropriately sized attenuator when connecting transmit ports to receive ports. On the long-reach optical cards (OC48 LR 16 Port 1550 and the OC192 LR 4 Port 1550), use a 15-dBm attenuator; on the short-reach optical cards (OC48 SR 16 Port 1310 and OC192 SR4 Port 1310), use a 3-dBm attenuator.
-
- Step 10** At the circuit source port:
- Connect the Tx connector of the test set to the Rx connector on the circuit source port.
 - Connect the test set Rx connector to the circuit Tx connector on the circuit source port.



Note Use appropriate attenuation on the test set receive connector; for more information, refer to the test set manual.

- Step 11** Verify that the test set displays a clean signal. If a clean signal is not present, repeat Steps 7 through 10 to make sure the test set and cabling are configured correctly. If the problem persists, refer to the *Cisco ONS 15600 Troubleshooting Guide*.
- Step 12** Inject BIT errors from the test set. Verify that the errors display at the test sets, indicating a complete end-to-end circuit.
- Step 13** Complete the “[DLP-E39 Optical 1+1 Manual Protection Switch Test](#)” task on page 16-55.
- Step 14** Set up and complete a long-term bit error rate (BER) test on the working and the protect spans. Use the existing configuration and follow your site requirements for the specified length of time. Record the test results and configuration.
- Step 15** Remove any loopbacks, switches, or test sets from the nodes after all testing is complete.
- Step 16** From the View menu, choose **Go To Network View**.
- Step 17** Click the **Alarms** tab. Complete the following steps:
- Verify that the alarm filter is not on. See the “[DLP-E157 Disable Alarm Filtering](#)” task on page 17-46 for instructions.
 - Verify that no unexplained alarms appear on the network. If unexplained alarms appear, resolve them before continuing. Refer to the *Cisco ONS 15600 Troubleshooting Guide*.
 - Complete the “[DLP-E265 Export CTC Data](#)” task on page 18-84 to export alarm data.
- Step 18** If a node fails any test, repeat the test to verify correct setup and configuration. If the test fails again, refer to the next level of support.
- Step 19** Complete the “[DLP-E163 Delete Circuits](#)” task on page 17-49 to delete the test circuit.
- After all tests are successfully completed and no alarms exist in the network, the network is ready for service application.
- Stop. You have completed this procedure.**

NTP-E163 Provision BLSR Nodes

Purpose	This procedure provisions ONS 15600 nodes for a BLSR.
Tools/Equipment	None
Prerequisite Procedures	NTP-E32 Verify Node Turn-Up , page 5-2
Required/As Needed	As needed
Onsite/Remote	Onsite
Security Level	Provisioning or higher

- Step 1** Complete the “[DLP-E234 Install Fiber-Optic Cables for BLSR Configurations](#)” task on page 18-47, verifying that the following rules are observed:

- Verify that the east port at one node is connected to the west port on an adjacent node, and that this east-to-west port connection is used at all BLSR nodes, similar to [Figure 5-1](#). In the figure, the OC-N drop card on the left side of the shelf is the west port, and the drop card on the right side of the shelf is considered the east port.

Figure 5-1 Four-Node, Two-Fiber BLSR Fiber Connection Example

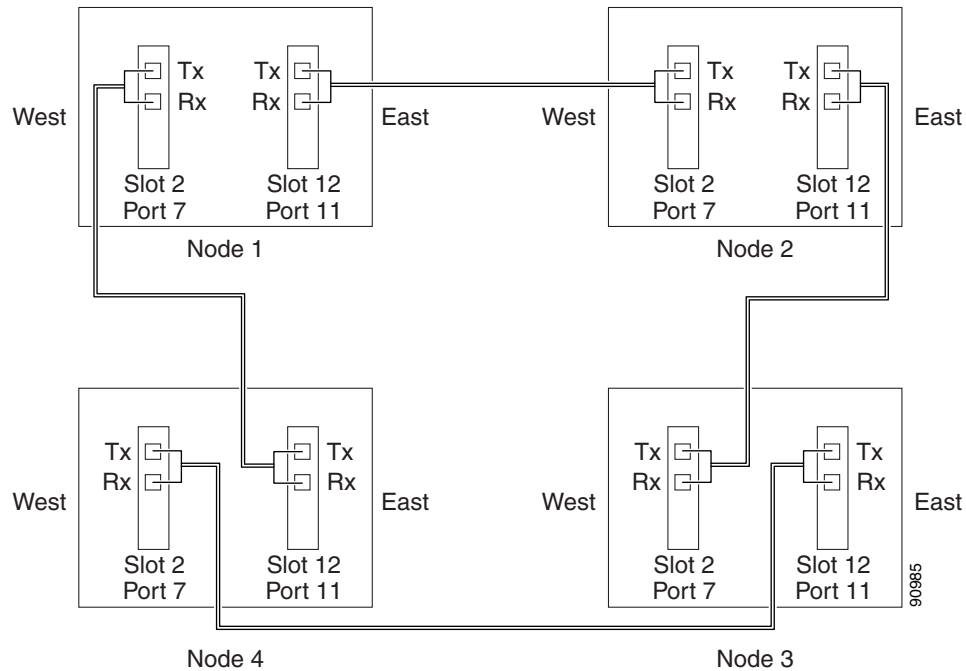

- For four-fiber BLSRs, verify that the same east-to-west port connection is used for the working and protect fibers, similar to [Figure 5-2](#). Verify that the working and protect port connections are not mixed. The working ports are the ports where you will provision the DCC terminations.

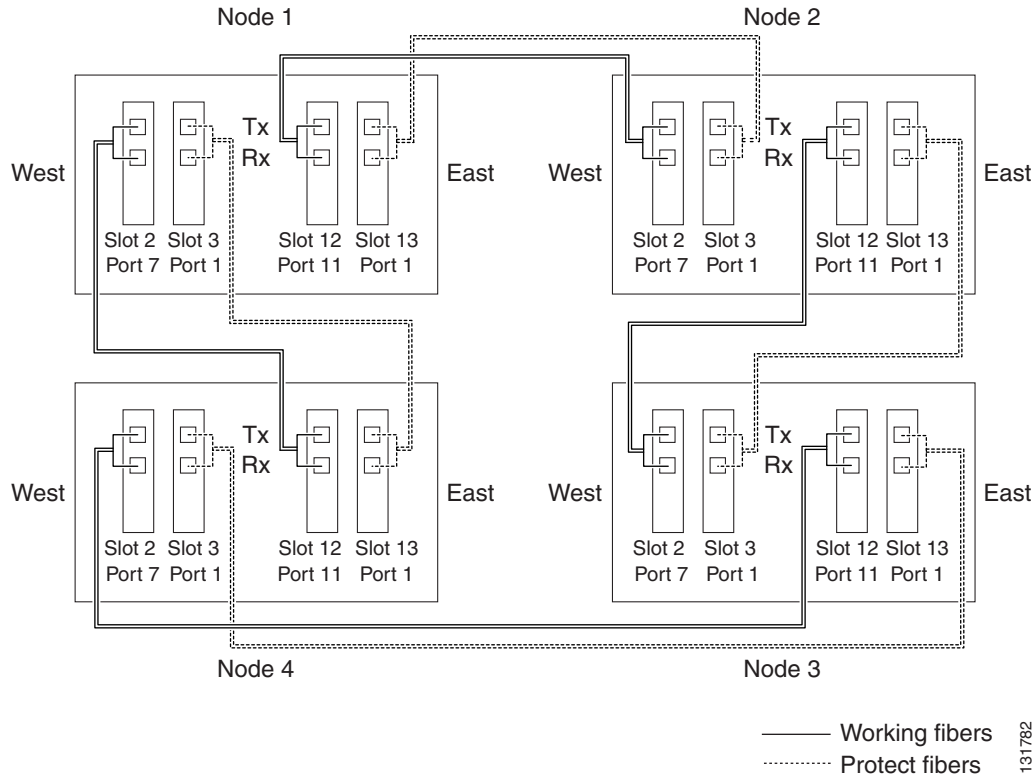
Figure 5-2 Four-Node, Four-Fiber BLSR Fiber Connection Example

- Step 2** Complete the “[DLP-E26 Log into CTC](#)” task on page 16-39 at the node that you want to configure in the BLSR. If you are already logged in, continue with Step 3.
- Step 3** Complete the “[DLP-E114 Provision Section DCC Terminations](#)” task on page 17-14. Provision the two cards/ports that will serve as the BLSR ports at the node. For four-fiber BLSRs, provision the DCC terminations on the OC-N ports that will carry the working traffic, but do not provision DCCs on the protect ports.



Note If an ONS 15600 is not connected to a corporate LAN, DCC provisioning must be performed through a direct (craft) connection to the node. Remote provisioning is possible only after all nodes in the network have DCCs provisioned to in-service OC-N ports.

- Step 4** For four-fiber BLSRs, complete the “[DLP-E115 Change the Service State for a Port](#)” task on page 17-16 to put the protect OC-N cards and ports in service.
- Step 5** As needed, complete the “[DLP-E190 Provision a Proxy Tunnel](#)” task on page 17-70.
- Step 6** As needed, complete the “[DLP-E191 Provision a Firewall Tunnel](#)” task on page 17-71.
- Step 7** As needed, complete the “[DLP-E194 Create a Provisionable Patchcord](#)” task on page 17-72.
- Step 8** If a BLSR span passes through third-party equipment that cannot transparently transport the K3 byte, complete the “[DLP-E116 Remap the K3 Byte](#)” task on page 17-17. This task is not necessary for most users.
- Step 9** Repeat Steps 2 through 8 at each node that will be in the BLSR. Verify that the DCC Termination Failure (EOC) and Loss of Signal (LOS) alarms are cleared after DCCs are provisioned on all nodes in the ring.

- Step 10** Complete the “[NTP-E164 Create a BLSR](#)” procedure on page 5-9.
Stop. You have completed this procedure.
-

NTP-E164 Create a BLSR

Purpose	This procedure creates a BLSR at each BLSR-provisioned node.
Tools/Equipment	None
Prerequisite Procedures	NTP-E163 Provision BLSR Nodes , page 5-6
Required/As Needed	Required
Onsite/Remote	Onsite or remote
Security Level	Provisioning or higher

- Step 1** Complete the “[DLP-E26 Log into CTC](#)” task on page 16-39 at a node on the network where you will create the BLSR. If you are already logged in, continue with Step 2.
- Step 2** Complete one of the following tasks:
- [DLP-E219 Create a Two-Fiber BLSR Using the BLSR Wizard](#), page 18-23—Use this task to create a two-fiber BLSR using the CTC BLSR wizard. The BLSR wizard checks to see that each node is ready for BLSR provisioning, then provisions all of the nodes at once. Using the BLSR wizard is recommended.
 - [DLP-E221 Create a Four-Fiber BLSR Using the BLSR Wizard](#), page 18-26—Use this task to create a four-fiber BLSR using the CTC BLSR wizard. The BLSR wizard checks to see that each node is ready for BLSR provisioning, then provisions all of the nodes at once. Using the BLSR wizard is recommended.
 - [DLP-E220 Create a Two-Fiber BLSR Manually](#), page 18-25—Use this task to provision a two-fiber BLSR manually at each node that will be in the BLSR.
 - [DLP-E222 Create a Four-Fiber BLSR Manually](#), page 18-28—Use this task to provision a four-fiber BLSR manually at each node that will be in the BLSR.
- Step 3** Complete the “[NTP-E89 Two-Fiber BLSR Acceptance Test](#)” procedure on page 5-10 or the “[NTP-E165 Four-Fiber BLSR Acceptance Test](#)” procedure on page 5-12.
Stop. You have completed this procedure.
-

NTP-E89 Two-Fiber BLSR Acceptance Test

Purpose	This procedure tests a two-fiber BLSR.
Tools/Equipment	Test set and cables appropriate for the test circuit
Prerequisite Procedures	NTP-E163 Provision BLSR Nodes, page 5-6 NTP-E164 Create a BLSR, page 5-9
Required/As Needed	As needed
Onsite/Remote	Onsite
Security Level	Provisioning or higher



Note

This procedure requires that you create test circuits and perform span switches around the ring. For clarity, “Node 1” refers to the login node where you begin the procedure. “Node 2” refers to the node connected to the East OC-N trunk (span) port of Node 1, “Node 3” refers to the node connected to the East OC-N trunk port of Node 2, etc.

-
- Step 1** Complete the [“DLP-E26 Log into CTC” task on page 16-39](#) at one of the nodes on the BLSR that you are testing. (This node will be called Node 1.) If you are already logged in, continue with [Step 2](#).
- Step 2** From the View menu, choose **Go To Network View**.
- Step 3** Click the **Alarms** tab. Complete the following steps:
- Verify that the alarm filter is not on. See the [“DLP-E157 Disable Alarm Filtering” task on page 17-46](#) for instructions.
 - Verify that no unexplained alarms appear on the network. If unexplained alarms appear, resolve them before continuing. Refer to the *Cisco ONS 15600 Troubleshooting Guide*.
 - Complete the [“DLP-E265 Export CTC Data” task on page 18-84](#) to export alarm data.
- Step 4** Click the **Conditions** tab. Complete the following steps:
- Verify that no unexplained conditions appear on the network. If unexplained conditions appear, resolve them before continuing. Refer to the *Cisco ONS 15600 Troubleshooting Guide*.
 - Complete the [“DLP-E265 Export CTC Data” task on page 18-84](#) to export condition data.
- Step 5** In network view, double-click Node 1.
- Step 6** Complete the [“DLP-E226 BLSR Exercise Ring Test” task on page 18-34](#).
- Step 7** Create a test circuit from Node 1 to the node connected to the east OC-N trunk port of Node 1. (This node will be called Node 2.) Complete the [“NTP-E160 Create an Automatically Routed Optical Circuit” procedure on page 6-4](#). When you set the circuit state, choose **IS** and check the **Apply to drop ports** check box.
- Step 8** Configure the test set for the test circuit type you created.
- Step 9** Verify the integrity of all patch cables that will be used in this test by connecting the test set Tx connector to the test set Rx connector. Use appropriate attenuation; for more information, refer to the test set manual. If the test set does not run error-free, check the cable for damage and check the test set to make sure it is set up correctly before going to the next step.
- Step 10** Create a physical loopback at the circuit destination port: attach one end of a patch cable to the destination port’s Tx connector; attach the other end to the port’s Rx connector.



Note Use an appropriately sized attenuator when connecting transmit ports to receive ports. On the long-reach optical cards (OC48 LR 16 Port 1550 and the OC192 LR 4 Port 1550), use a 15-dBm attenuator; on the short-reach optical cards (OC48 SR 16 Port 1310 and OC192 SR4 Port 1310), use a 3-dBm attenuator.

- Step 11** At the circuit source port:
- Connect the test set Tx connector, using appropriate attenuation, to the circuit Rx connector.
 - Connect the test set Rx connector, using appropriate attenuation, to the circuit Tx connector.



Note For information about the appropriate level of attenuation, refer to the test set manual.

- Step 12** Verify that the test set displays a clean signal. If a clean signal is not present, repeat Steps 7 through 11 to make sure the test set and cabling are configured correctly.
- Step 13** Inject BIT errors from the test set. Verify that the errors display at the test set, verifying a complete end-to-end circuit.
- Step 14** Complete the “[DLP-E227 BLSR Switch Test](#)” task on page 18-35 at Node 1.
- Step 15** Set up and complete a BER test on the test circuit. Use the existing configuration and follow your site requirements for length of time. Record the test results and configuration.
- Step 16** Complete the “[DLP-E163 Delete Circuits](#)” task on page 17-49 for the test circuit.
- Step 17** Repeat Steps 5 through 16 for Nodes 2 and higher, working your way around the BLSR, testing each node and span in the ring. Work your way around the BLSR creating test circuits between every two consecutive nodes.
- Step 18** After you test the entire ring, remove any loopbacks and test sets from the nodes.
- Step 19** If a node fails any test, repeat the test while verifying correct setup and configuration. If the test fails again, refer to the next level of support.

After all tests are successfully completed and no alarms exist in the network, the network is ready for service application. Continue with [Chapter 6, “Create Circuits.”](#)

Stop. You have completed this procedure.

NTP-E165 Four-Fiber BLSR Acceptance Test

Purpose	This procedure tests a four-fiber BLSR.
Tools/Equipment	Test set and cables appropriate to the test circuit you will create
Prerequisite Procedures	NTP-E163 Provision BLSR Nodes, page 5-6 NTP-E164 Create a BLSR, page 5-9
Required/As Needed	As needed
Onsite/Remote	Onsite
Security Level	Provisioning and higher



Caution

This procedure might be service affecting if performed on a node carrying traffic.



Note

This procedure requires that you create test circuits and perform a ring switch. For clarity, “Node 1” refers to the login node where you begin the procedure. “Node 2” refers to the node connected to the east OC-N trunk (span) port of Node 1, “Node 3” refers to the node connected to the east OC-N trunk port of Node 2, and so on.

-
- Step 1** Complete the [“DLP-E26 Log into CTC” task on page 16-39](#) on the BLSR you are testing. (This node will be called Node 1.) If you are already logged in, continue with Step 2.
- Step 2** From the View menu, choose **Go to Network View**.
- Step 3** Click the **Alarms** tab.
- Verify that the alarm filter is not on. See the [“DLP-E157 Disable Alarm Filtering” task on page 17-46](#) as necessary.
 - Verify that no unexplained alarms appear on the network. If unexplained alarms appear, resolve them before continuing. Refer to the *Cisco ONS 15600 Troubleshooting Guide* if necessary.
 - As necessary, complete the [“DLP-E265 Export CTC Data” task on page 18-84](#) to export the alarm information.
- Step 4** Click the **Conditions** tab.
- Verify that no unexplained conditions appear on the network. If unexplained conditions appear, resolve them before continuing. Refer to the *Cisco ONS 15600 Troubleshooting Guide* if necessary.
 - As necessary, complete the [“DLP-E265 Export CTC Data” task on page 18-84](#) to export the condition information.
- Step 5** On the network map, double-click Node 1.
- Step 6** Complete the [“DLP-E224 Four-Fiber BLSR Exercise Span Test” task on page 18-30](#).
- Step 7** Complete the [“DLP-E226 BLSR Exercise Ring Test” task on page 18-34](#).
- Step 8** Create a test circuit from Node 1 to the node connected to the east OC-N trunk port of Node 1. (This node will be called Node 2.) Complete the [“NTP-E160 Create an Automatically Routed Optical Circuit” procedure on page 6-4](#). When you set the circuit state, choose **IS** and check the **Apply to drop ports** check box.
- Step 9** Configure the test set for the test circuit type you created.

- Step 10** Verify the integrity of all patch cables that will be used in this test by connecting one end of the cable to the test set Tx connector and the other end of the cable to the test set Rx connector. If the test set does not run error-free, check the cable for damage and check the test set to make sure it is set up correctly before continuing.
- Step 11** Create a physical loopback at the circuit destination port. To do so, attach one end of a patch cable to the destination port's Tx connector; attach the other end to the port's Rx connector.
- Step 12** At the circuit source port:
- Connect the Tx connector of the test set to the circuit Rx connector.
 - Connect the test set Rx connector to the circuit Tx connector.
- Step 13** Verify that the test set shows a clean signal. If a clean signal does not appear, repeat Steps 6 through 12 to make sure the test set and cabling are configured correctly.
- Step 14** Inject global BIT errors from the test set. Verify that the errors appear at the test set, verifying a complete end-to-end circuit.
- Step 15** Complete the [“DLP-E227 BLSR Switch Test” task on page 18-35](#) to test the BLSR protection switching at Node 1.
- Step 16** Complete the [“DLP-E225 Four-Fiber BLSR Span Switching Test” task on page 18-32](#) at Node 1.
- Step 17** Set up and complete a BER test on the test circuit between Node 1 and 2. Use the existing configuration and follow your site requirements for length of time. Record the test results and configuration.
- Step 18** Complete the [“DLP-E163 Delete Circuits” task on page 17-49](#) for the test circuit.
- Step 19** At Node 2, repeat Steps 5 through 18, creating a test circuit between Node 2 and the node connected to the east OC-N trunk (span) port of Node 2 (Node 3). Work your way around the BLSR creating test circuits between every two consecutive nodes.
- Step 20** After you test the entire ring, remove any loopbacks and test sets from the nodes.
- Step 21** Click the **Alarms** tab.
- Verify that the alarm filter is not on. See the [“DLP-E157 Disable Alarm Filtering” task on page 17-46](#) as necessary.
 - Verify that no unexplained alarms appear. If unexplained alarms appear, resolve them before continuing. Refer to the *Cisco ONS 15600 Troubleshooting Guide* if necessary.
 - As necessary, complete the [“DLP-E265 Export CTC Data” task on page 18-84](#) to export the alarm information.
- Step 22** Click the **Conditions** tab.
- Verify that no unexplained conditions appear. If unexplained conditions appear, resolve them before continuing. Refer to the *Cisco ONS 15600 Troubleshooting Guide* if necessary.
 - As necessary, complete the [“DLP-E265 Export CTC Data” task on page 18-84](#) to export the condition information.
- Step 23** If a node fails any test, repeat the test while verifying correct setup and configuration. If the test fails again, refer to the next level of support.

After all tests are successfully completed and no alarms exist in the network, the network is ready for service application. Continue with [Chapter 6, “Create Circuits.”](#)

Stop. You have completed this procedure.

NTP-E170 Provision a Traditional BLSR Dual-Ring Interconnect

Purpose	This procedure provisions BLSRs in a traditional DRI topology. DRIs interconnect two or more BLSRs to provide an additional level of protection.
Tools/Equipment	None
Prerequisite Procedures	NTP-E32 Verify Node Turn-Up, page 5-2
Required/As Needed	As needed
Onsite/Remote	Onsite
Security Level	Provisioning or higher



Note To route circuits on the DRI, you must check the Dual Ring Interconnect check box during circuit creation.

-
- Step 1** Complete the “[DLP-E26 Log into CTC](#)” task on page 16-39. If you are already logged in, continue with Step 2.
- Step 2** Complete the following steps if you have not provisioned the BLSRs that you will interconnect in a BLSR DRI. If the BLSRs are created, go to Step 3.
- a. Complete the “[NTP-E163 Provision BLSR Nodes](#)” task on page 5-6 to provision the BLSRs.
 - b. Complete the “[NTP-E164 Create a BLSR](#)” procedure on page 5-9 to create the BLSRs.
 - c. Complete the “[NTP-E89 Two-Fiber BLSR Acceptance Test](#)” procedure on page 5-10 to test two-fiber BLSRs.
- Step 3** Verify that the BLSR DRI interconnect nodes have OC-N cards installed and have fiber connections to the other interconnect nodes. The following rules apply:
- The OC-N cards that will connect the BLSRs must be installed at the interconnect nodes.
 - The interconnect nodes must have fiber connections. [Figure 5-3](#) shows an example of fiber connections for a traditional two-fiber BLSR DRI.

Figure 5-3 Traditional Two-Fiber BLSR DRI Fiber Connection Example

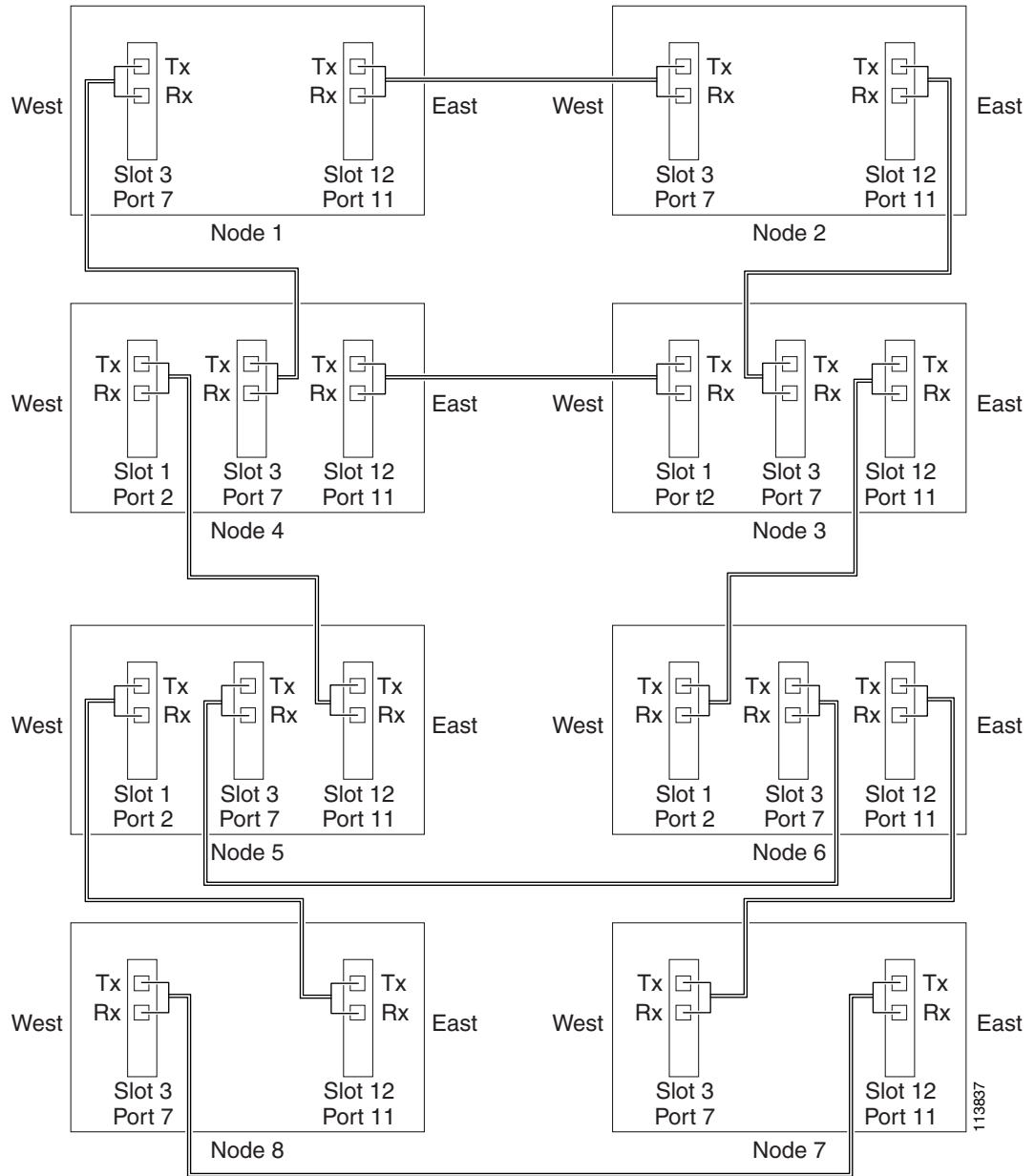

Stop. You have completed this procedure.

NTP-E171 Provision an Integrated BLSR Dual-Ring Interconnect

Purpose	This procedure provisions BLSRs in an integrated DRI topology.
Tools/Equipment	None
Prerequisite Procedures	NTP-E32 Verify Node Turn-Up, page 5-2
Required/As Needed	As needed
Onsite/Remote	Onsite
Security Level	Provisioning or higher

-
- Step 1** Complete the “[DLP-E26 Log into CTC](#)” task on page 16-39 at a node in the BLSR DRI network. If you are already logged in, continue with Step 2.
- Step 2** Complete the following steps if you have not provisioned the BLSRs that you will interconnect in a BLSR DRI. If the BLSRs are created, go to Step 3.
- a. Complete the “[NTP-E163 Provision BLSR Nodes](#)” task on page 5-6 to provision the BLSRs.
 - b. Complete the “[NTP-E164 Create a BLSR](#)” task on page 5-9 to create the BLSRs.
 - c. Complete the “[NTP-E89 Two-Fiber BLSR Acceptance Test](#)” task on page 5-10 to test two-fiber BLSRs.
- Step 3** Verify that the BLSR DRI interconnect node has OC-N cards installed and has fiber connections to the other interconnect node. The following rules apply:
- The OC-N cards that will connect the BLSRs must be installed at the two interconnect nodes.
 - The two interconnect nodes must have the correct fiber connections. [Figure 5-4](#) shows an example of an integrated two-fiber BLSR DRI configuration.

Figure 5-4 Integrated Two-Fiber BLSR DRI Example

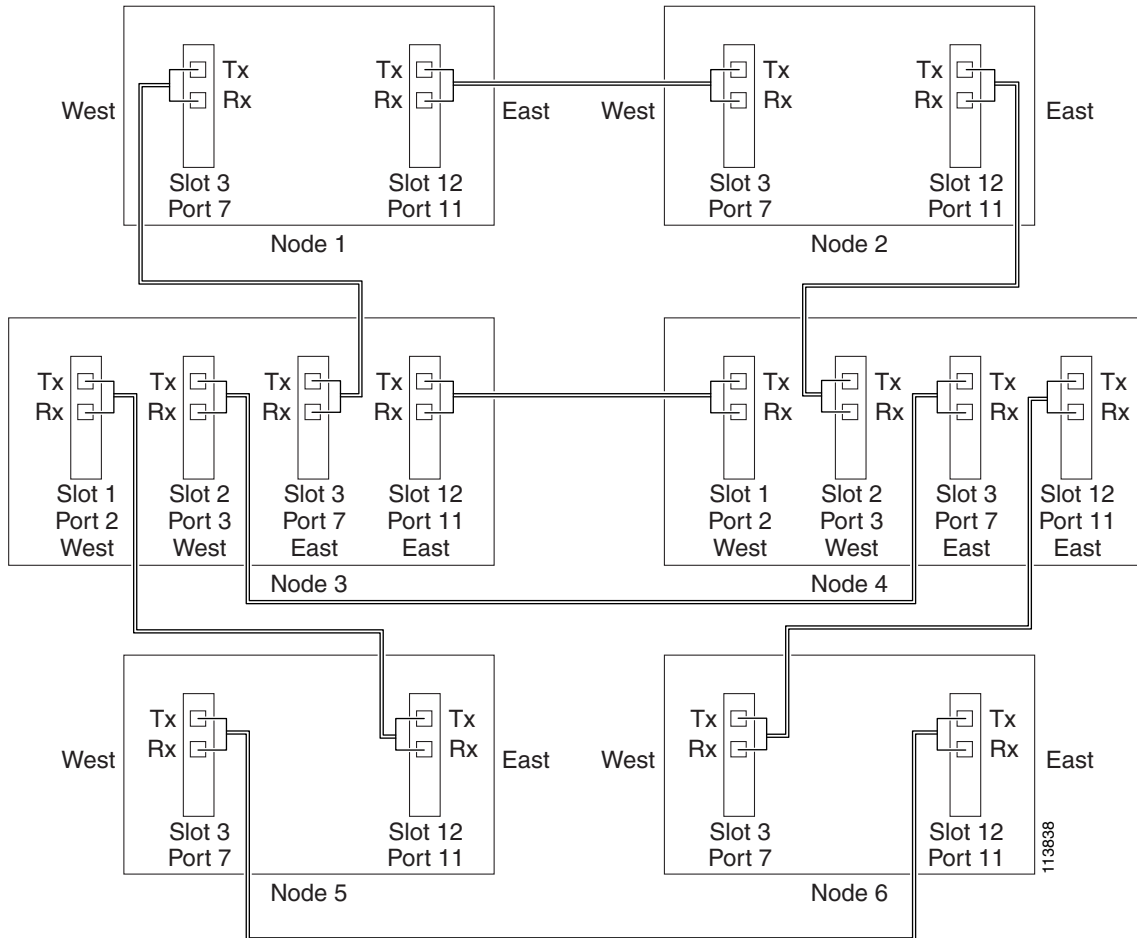

Stop. You have completed this procedure.

NTP-E35 Provision Path Protection Nodes

Purpose	This procedure provisions ONS 15600 nodes for a path protection.
Tools/Equipment	None
Prerequisite Procedures	NTP-E32 Verify Node Turn-Up, page 5-2
Required/As Needed	As needed
Onsite/Remote	Onsite
Security Level	Provisioning or higher

- Step 1** Verify that the fiber is correctly connected to the ports on the path protection trunk (span) OC-N card. Fiber connected to an east port at one node should be connected to the west port on an adjacent node using an appropriately sized attenuator, fibered similarly to the example in [Figure 5-5](#).

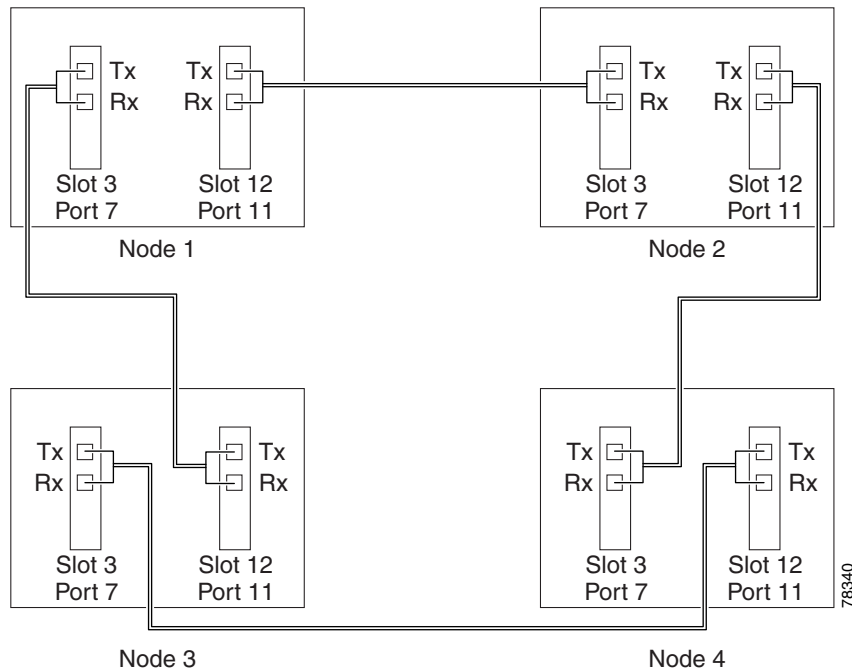
Figure 5-5 Path Protection Fiber Connection Example

- Step 2** Complete the “[DLP-E26 Log into CTC](#)” task on page 16-39 at a node on the path protection that you are turning up. If you are already logged in, continue with [Step 3](#).
- Step 3** Complete the “[DLP-E114 Provision Section DCC Terminations](#)” task on page 17-14 or the “[DLP-E189 Provision Line DCC Terminations](#)” task on page 17-68 for the cards/ports that will host the path protection on the node, for example, Slot 3 (OC-48)/Port 7 and Slot 12 (OC-48)/ Port 11.



Note If an ONS 15600 is not connected to a corporate LAN, you must perform Section DCC (SDCC) or Line DCC (LDCC) provisioning through a local craft connection. Remote provisioning is possible only after all nodes in the network have SDCC or LDCC terminations provisioned to in-service OC-N ports.

- Step 4** Repeat Steps 2 and 3 for each node in the path protection.
- Step 5** As needed, complete the “[DLP-E190 Provision a Proxy Tunnel](#)” task on page 17-70.
- Step 6** As needed, complete the “[DLP-E191 Provision a Firewall Tunnel](#)” task on page 17-71.
- Step 7** As needed, complete the “[DLP-E194 Create a Provisionable Patchcord](#)” task on page 17-72.
- Step 8** If necessary, complete the “[DLP-E115 Change the Service State for a Port](#)” task on page 17-16 for all ports that you configured as SDCC or LDCC terminations. (CTC usually puts ports in service by default when you complete the DCC terminations.) Repeat this step at each node that will be in the path protection.
- Step 9** Complete the “[NTP-E36 Path Protection Acceptance Test](#)” procedure on page 5-19.

Stop. You have completed this procedure.

NTP-E36 Path Protection Acceptance Test

Purpose	This procedure creates drop ports at two of the nodes in the path protection to support test set connections (source and destination ports).
Tools/Equipment	Test set and cables appropriate to the test circuit you will create.
Prerequisite Procedures	NTP-E32 Verify Node Turn-Up, page 5-2 NTP-E35 Provision Path Protection Nodes, page 5-17
Required/As Needed	Required if you provisioned a path protection
Onsite/Remote	Onsite
Security Level	Provisioning or higher

-
- Step 1** Complete the “[DLP-E26 Log into CTC](#)” task on page 16-39 at one of the nodes on the path protection that you are testing. If you are already logged in, continue with [Step 2](#).
- Step 2** From the View menu, choose **Go To Network View**.
- Step 3** Click the **Alarms** tab. Complete the following steps:
- Verify that the alarm filter is not on. See the “[DLP-E157 Disable Alarm Filtering](#)” task on page 17-46 for instructions.
 - Verify that no unexplained alarms appear on the network. If unexplained alarms appear, resolve them before continuing. Refer to the *Cisco ONS 15600 Troubleshooting Guide*.
 - Complete the “[DLP-E265 Export CTC Data](#)” task on page 18-84 to export alarm data.
- Step 4** Click the **Conditions** tab. Complete the following steps:
- Verify that no unexplained conditions appear on the network. If unexplained conditions appear, resolve them before continuing. Refer to the *Cisco ONS 15600 Troubleshooting Guide*.
 - Complete the “[DLP-E265 Export CTC Data](#)” task on page 18-84 to export condition data.
- Step 5** On the network map, double-click the node that you logged into in [Step 1](#).
- Step 6** Create a fully protected circuit as appropriate for the path protection spans. If an OC-192 test set is not available, create an OC-48 test circuit across an OC-192 span. See the “[NTP-E160 Create an Automatically Routed Optical Circuit](#)” procedure on page 6-4. When you set the circuit state, choose **IS** and check the **Apply to drop ports** check box.
- Step 7** Configure the test set for the test circuit type you created. For information about configuring your test set, consult your test set user guide.
- Step 8** Verify the integrity of all patch cables that will be used in this test by connecting one end to the test set Tx connector and the other to the test set Rx connector. Use appropriate attenuation on the test set receive connector; for more information, refer to the test set manual. If the test set does not run error-free, check the cable for damage and check the test set to make sure it is set up correctly before going to [Step 9](#).
- Step 9** Create a physical loopback at the circuit destination port:
- Attach one end of a patch cable to the destination port’s Tx connector.
 - Attach the other end to the port’s Rx connector.



Note Use an appropriately sized attenuator when connecting transmit ports to receive ports. On the long-reach optical cards (OC48 LR 16 Port 1550 and the OC192 LR 4 Port 1550), use a 15-dBm attenuator; on the short-reach optical cards (OC48 SR 16 Port 1310 and OC192 SR4 Port 1310), use a 3-dBm attenuator.

- Step 10** At the circuit source port:
- a. Connect the Tx connector of the test set to the circuit Rx connector.
 - b. Connect the test set Rx connector to the circuit Tx connector.



Note Use appropriate attenuation on the test set receive connector; for more information, refer to the test set manual.

- Step 11** Verify that the test set has a clean signal. If a clean signal is not present, repeat Steps 6 through 10 to verify that the test set and cabling are configured correctly.
- Step 12** Inject BIT errors from the test set. Verify that the errors display at the test set, indicating a complete end-to-end circuit.
- Step 13** From the View menu, choose **Go To Network View**.
- Step 14** Click one of the two spans coming from the circuit source node.
- Step 15** Complete the “[DLP-E40 Path Protection Switching Test](#)” task on page 16-56.
Although a service interruption under 60 ms may occur, the test circuit should continue to work before, during, and after the switches. If the circuit stops working, do not continue. Contact your next level of support.
- Step 16** In network view, click the other circuit source span and repeat [Step 15](#).
- Step 17** Set up and complete a long-term BER test. Use the existing configuration and follow your site requirements for length of time. Record the test results and configuration.
- Step 18** Remove any loopbacks, switches, or test sets from the nodes after all testing is complete.
- Step 19** From the View menu, choose **Go To Network View**.
- Step 20** Click the **Alarms** tab. Complete the following steps:
- a. Verify that the alarm filter is not on. See the “[DLP-E157 Disable Alarm Filtering](#)” task on page 17-46 for instructions.
 - b. Verify that no unexplained alarms appear on the network. If unexplained alarms appear, resolve them before continuing. Refer to the *Cisco ONS 15600 Troubleshooting Guide*.
 - c. Complete the “[DLP-E265 Export CTC Data](#)” task on page 18-84 to export alarm data.
- Step 21** Click the **Conditions** tab. Complete the following steps:
- a. Verify that no unexplained conditions appear on the network. If unexplained conditions appear, resolve them before continuing. Refer to the *Cisco ONS 15600 Troubleshooting Guide*.
 - b. Complete the “[DLP-E265 Export CTC Data](#)” task on page 18-84 to export condition data.

Step 22 If a node fails any test, repeat the test verifying correct setup and configuration. If the test fails again, refer to the next level of support.

After all tests are successfully completed and no alarms exist in the network, the network is ready for service application.

Stop. You have completed this procedure.

NTP-E137 Provision a Traditional Path Protection Dual-Ring Interconnect

Purpose	This procedure provisions path protection configurations in a traditional DRI topology. DRIs interconnect two or more path protection configurations to provide an additional level of protection.
Tools/Equipment	None
Prerequisite Procedures	NTP-E32 Verify Node Turn-Up, page 5-2
Required/As Needed	As needed
Onsite/Remote	Onsite
Security Level	Provisioning or higher



Note To route circuits on the DRI, you must check the Dual Ring Interconnect check box during circuit creation.

Step 1 Complete the “[DLP-E26 Log into CTC](#)” task on page 16-39. If you are already logged in, continue with Step 2.

Step 2 Complete the following steps if you have not provisioned the path protection configurations that you will interconnect in a path protection DRI. If the path protection configurations are created, go to Step 3.

- Complete the “[NTP-E35 Provision Path Protection Nodes](#)” procedure on page 5-17 to provision the path protection configurations.
- Complete the “[NTP-E36 Path Protection Acceptance Test](#)” procedure on page 5-19 to test the path protection configurations.



Note All path protection configurations that will be interconnected must have the same OC-N rate.

Step 3 Verify that the path protection DRI interconnect nodes have OC-N cards installed and have fiber connections to the other interconnect node. Note that:

- The OC-N cards that will connect the path protection configurations must be installed at the interconnect nodes. The OC-N cards in the path protection nodes and the interconnect nodes must be the same type.
- The interconnect nodes must have fiber connections.

An example is shown in [Figure 5-6](#). This example shows a path protection DRI with two rings, Nodes 1 through 4 and 5 through 8. In the example, an additional OC-N is installed in Slot 12, Port 3 at Node 4 and connected to an OC-N in Slot 4, Port 2 at Node 6. Nodes 3 and 5 are interconnected with OC-N cards in Slot 4, Port 2 (Node 3) and Slot 12, Port 3 (Node 5).

Figure 5-6 Traditional Path Protection DRI Fiber Connection Example

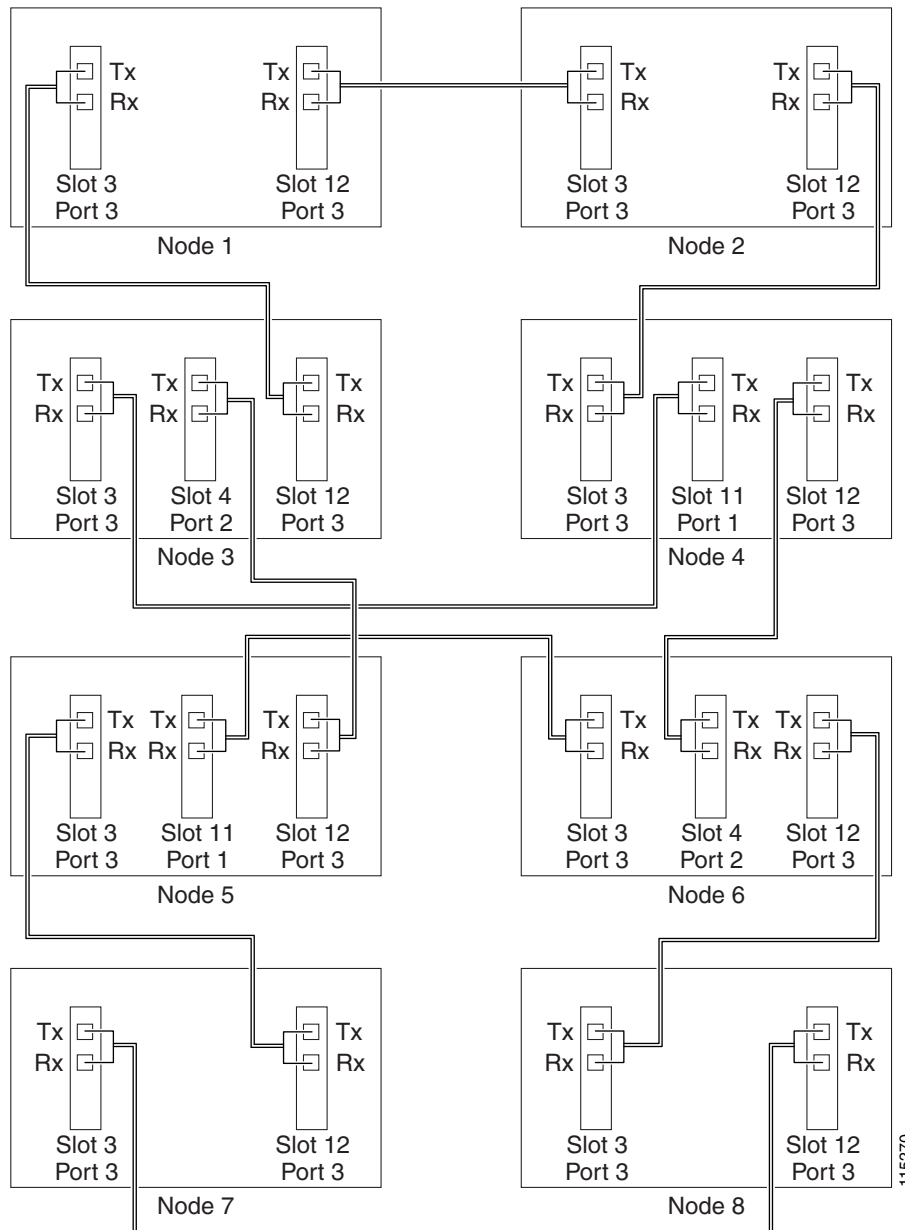

Stop. You have completed this procedure.

NTP-E138 Provision an Integrated Path Protection Dual-Ring Interconnect

Purpose	This procedure provisions path protection configurations in an integrated DRI topology.
Tools/Equipment	None
Prerequisite Procedures	NTP-E32 Verify Node Turn-Up, page 5-2
Required/As Needed	As needed
Onsite/Remote	Onsite
Security Level	Provisioning or higher

-
- Step 1** Complete the “[DLP-E26 Log into CTC](#)” task on page 16-39 at a node in the path protection DRI network. If you are already logged in, continue with Step 2.
- Step 2** Complete the following steps if you have not provisioned the path protection configurations that you will interconnect in a path protection DRI. If the path protection configurations are created, continue with Step 3.
- Complete the “[NTP-E35 Provision Path Protection Nodes](#)” procedure on page 5-17 to provision the path protection configurations.
 - Complete the “[NTP-E36 Path Protection Acceptance Test](#)” procedure on page 5-19 to test the path protection configurations.



Note All path protection configurations that will be interconnected must have the same OC-N rate.

- Step 3** Verify that the path protection DRI interconnect nodes have OC-N cards installed and have fiber connections to the other interconnect node. Note that:
- The OC-N cards that will connect the path protection configurations must be installed at the interconnect nodes. The OC-N cards in the path protection nodes and the interconnect nodes must be the same type.
 - The interconnect nodes must have the correct fiber connections.

An example is shown in [Figure 5-7](#). This example shows a path protection DRI with two rings.

Figure 5-7 Integrated Path Protection DRI Example

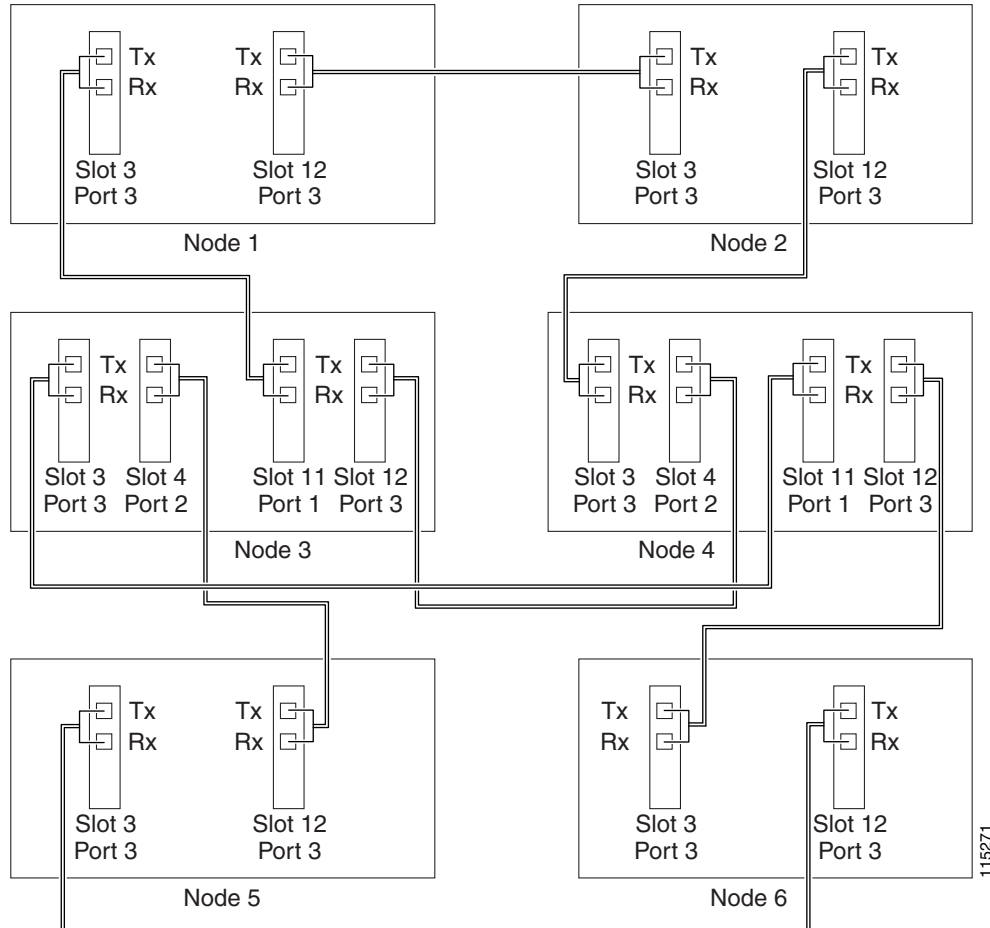

Stop. You have completed this procedure.

NTP-E172 Provision a Traditional BLSR/Path Protection Dual-Ring Interconnect

Purpose	This procedure provisions a BLSR and a path protection in a traditional DRI topology. DRIs interconnect ring topologies to provide an additional level of protection.
Tools/Equipment	None
Prerequisite Procedures	NTP-E32 Verify Node Turn-Up, page 5-2
Required/As Needed	As needed
Onsite/Remote	Onsite
Security Level	Provisioning or higher

**Note**

To route circuits on the DRI, you must check the Dual Ring Interconnect check box during circuit creation.

-
- Step 1** Complete the “[DLP-E26 Log into CTC](#)” task on page 16-39. If you are already logged in, continue with Step 2.
- Step 2** Complete the following steps if you have not provisioned the BLSR and path protection that you will interconnect in a traditional DRI. If the BLSR and path protection are created, go to Step 3.
- a. To provision and test the BLSR, complete the following:
 - [NTP-E163 Provision BLSR Nodes](#), page 5-6
 - [NTP-E164 Create a BLSR](#), page 5-9
 - [NTP-E89 Two-Fiber BLSR Acceptance Test](#), page 5-10
 - b. To provision and test the path protection, complete the following:
 - [NTP-E35 Provision Path Protection Nodes](#), page 5-17
 - [NTP-E36 Path Protection Acceptance Test](#), page 5-19
- Step 3** Verify that the DRI interconnect nodes have OC-N cards installed and have fiber connections to the other interconnect node:
- The OC-N cards that will connect the BLSR and path protection must be installed at the interconnect nodes. The OC-N ports in the path protection nodes and the interconnect nodes must be the same rate.
 - The interconnect nodes must have fiber connections. An example is shown in [Figure 5-8](#).

Figure 5-8 Traditional BLSR to Path Protection DRI Fiber Connection Example

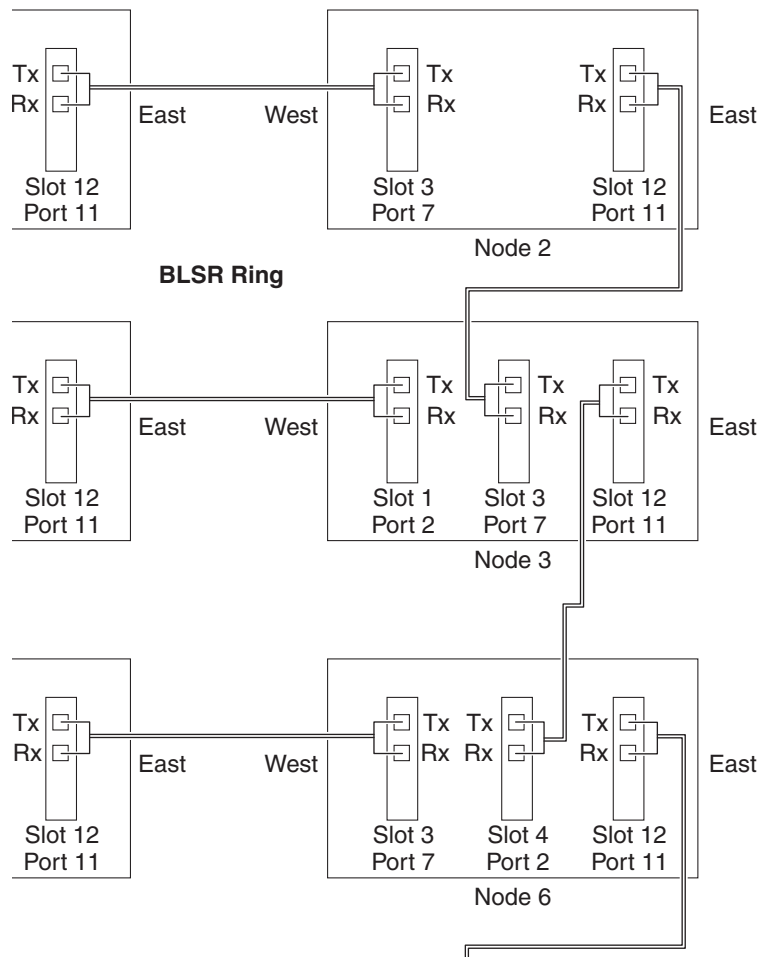

Stop. You have completed this procedure.

NTP-E173 Provision an Integrated BLSR/Path Protection Dual-Ring Interconnect

Purpose	This procedure provisions a BLSR and a path protection in an integrated DRI topology.
Tools/Equipment	None
Prerequisite Procedures	NTP-E32 Verify Node Turn-Up, page 5-2
Required/As Needed	As needed
Onsite/Remote	Onsite
Security Level	Provisioning or higher

-
- Step 1** Complete the “[DLP-E26 Log into CTC](#)” task on [page 16-39](#) at a node in the BLSR and path protection DRI network. If you are already logged in, continue with Step 2.
- Step 2** Complete the following steps if you have not provisioned the BLSR and path protection that you will interconnect in an integrated DRI. If the BLSR and path protection are created, continue with Step 3.
- a. To provision and test the BLSR, complete the following:
 - [NTP-E163 Provision BLSR Nodes, page 5-6](#)
 - [NTP-E164 Create a BLSR, page 5-9](#)
 - [NTP-E89 Two-Fiber BLSR Acceptance Test, page 5-10](#)
 - b. To provision and test the path protection, complete the following:
 - [NTP-E35 Provision Path Protection Nodes, page 5-17](#)
 - [NTP-E36 Path Protection Acceptance Test, page 5-19](#)
- Step 3** Verify that the BLSR and path protection DRI interconnect nodes have OC-N cards installed and have fiber connections to the other interconnect node:
- The OC-N cards that will connect the BLSR and path protection must be installed at the interconnect nodes. The OC-N ports in the path protection nodes and the interconnect nodes must be the same rate.
 - The interconnect nodes must have the correct fiber connections. An example is shown in [Figure 5-9](#).

Figure 5-9 Integrated BLSR to Path Protection DRI Example

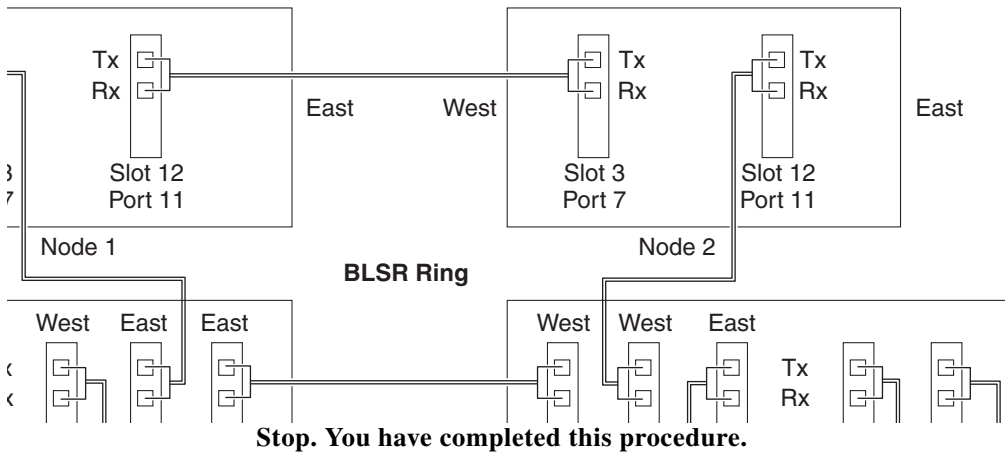

NTP-E141 Provision an Open-Ended Path Protection

Purpose	This procedure provisions ONS 15600s in an open-ended path protection connected to a third-party vendor network. This topology allows you to route a circuit from one ONS 15600 network to another ONS 15600 network through the third-party network.
Tools/Equipment	None
Prerequisite Procedures	NTP-E32 Verify Node Turn-Up, page 5-2
Required/As Needed	As needed
Onsite/Remote	Onsite
Security Level	Provisioning or higher

- Step 1** Verify that the fiber is correctly connected to the path protection trunk (span) OC-N cards at each open-ended path protection node. [Figure 5-10](#) shows an example. Node 1 is connected to ONS 15600 Nodes 2 and 3 through Slots 12 and 2. Trunk cards at Nodes 2 and 3 are connected to the third-party vendor equipment.

Figure 5-10 ONS 15600 Open-Ended Path Protection Configurations Fiber Connection Example

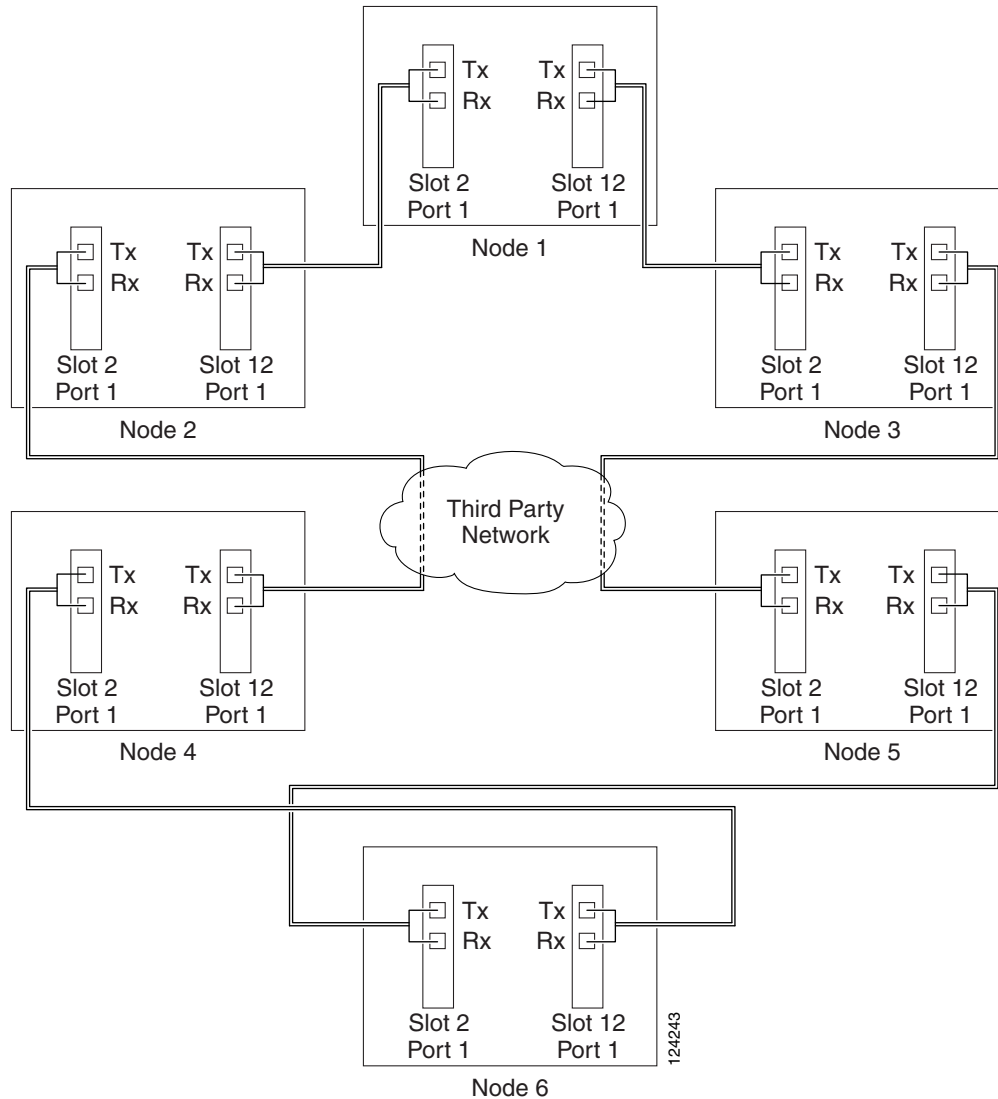

- Step 2** Verify that the third-party cards or units to which the ONS 15600 trunk cards are connected are the same OC-N rate as the ONS 15600 trunk cards. The third-party time slots must match the ONS 15600 card time slots to which they are connected. For example, if your trunk card is an OC-48, the third-party vendor card or unit must have STSs 1-48 available.
- Step 3** Log into an ONS 15600 in the path protection you are turning up. See the “[DLP-E26 Log into CTC](#)” task on page 16-39. If you are already logged in, continue with Step 4.
- Step 4** Complete the “[DLP-E114 Provision Section DCC Terminations](#)” task on page 17-14 or the “[DLP-E189 Provision Line DCC Terminations](#)” task on page 17-68 for the ONS 15600 cards and ports that are connected to another ONS 15600. Do not create DCC or LDCC terminations for the card and port that connects to the third-party equipment. For example in [Figure 5-10](#), DCC terminations are created at the following cards and ports:
- Nodes 1 and 6: Slot 2, Port 1 and Slot 12, Port 1
 - Node 2 and 5: Slot 12, Port 1
 - Node 3 and 4: Slot 2, Port 1



Note If an ONS 15600 is not connected to a corporate LAN, DCC or LDCC provisioning must be performed through a direct (craft) connection. Remote provisioning is possible only after all nodes in the network have DCC or LDCC terminations provisioned to in-service OC-N ports.

- Step 5** Repeat Steps 3 and 4 for each node in the path protection.
- Step 6** As needed, complete the “[DLP-E190 Provision a Proxy Tunnel](#)” task on page 17-70.
- Step 7** As needed, complete the “[DLP-E191 Provision a Firewall Tunnel](#)” task on page 17-71.
- Step 8** As needed, complete the “[DLP-E194 Create a Provisionable Patchcord](#)” task on page 17-72.
- Step 9** Following the documentation provided by the third-party vendor, provision the optical loop leading from the ONS 15600 connection at one end to the ONS 15600 connection at the other end. In other words, you will create an open-ended path protection using procedures for the third-party equipment.
- Step 10** Complete the “[NTP-E142 Open-Ended Path Protection Acceptance Test](#)” procedure on page 5-31. Stop. You have completed this procedure.

NTP-E142 Open-Ended Path Protection Acceptance Test

Purpose	This procedure tests an open-ended path protection.
Tools/Equipment	Test set and cables appropriate to the test circuit you will create.
Prerequisite Procedures	NTP-E141 Provision an Open-Ended Path Protection , page 5-29
Required/As Needed	As needed
Onsite/Remote	Onsite
Security Level	Provisioning or higher



Caution

This procedure might be service-affecting if performed on a node carrying traffic.



Note

Although a service interruption under 60 ms might occur, the test circuit should continue to work before, during, and after the switches. If the circuit stops working, do not continue. Contact your next level of support.

- Step 1** Complete the “[DLP-E26 Log into CTC](#)” task on page 16-39 at the node that will be the source node for traffic traversing the third-party network. If you are already logged in, continue with Step 2.
- Step 2** From the View menu, choose **Go to Network View**.
- Step 3** Click the **Alarms** tab. Complete the following steps:
- Verify that the alarm filter is not on. See the “[DLP-E157 Disable Alarm Filtering](#)” task on page 17-46 for instructions.
 - Verify that no unexplained alarms appear on the network. If unexplained alarms appear, resolve them before continuing. Refer to the *Cisco ONS 15600 Troubleshooting Guide*.
 - Complete the “[DLP-E265 Export CTC Data](#)” task on page 18-84 to export alarm information.

- Step 4** Click the **Conditions** tab. Complete the following steps:
- Verify that no unexplained conditions appear on the network. If unexplained conditions appear, resolve them before continuing. Refer to the *Cisco ONS 15600 Troubleshooting Guide*.
 - Complete the “[DLP-E265 Export CTC Data](#)” task on page 18-84 to export condition data.
- Step 5** On the network map, double-click the node that you logged into in Step 1.
- Step 6** Create a test circuit from that node to the OC-N trunk (span) cards on the nodes that connect to the third-party network. For example, in [Figure 5-10 on page 5-30](#), a circuit is created from Node 1 to the Slot 12 OC-N card at Node 2, and a secondary circuit destination is created on the Slot 2 OC-N card at Node 3. See the “[NTP-E160 Create an Automatically Routed Optical Circuit](#)” procedure on page 6-4. When you set the circuit state, choose **IS** and check the **Apply to drop ports** check box.
- Step 7** Create a circuit within the third-party network from ONS 15600 connection ports to the second set of ONS 15600 connection ports on both path protection spans. Refer to the third-party equipment documentation for circuit creation procedures.
- Step 8** Repeat [Step 6](#) to create a second circuit at the terminating node on the other side of the third-party network. In [Figure 5-10](#), this is Node 6. However, this circuit will have two sources, one at Node 4/Slot 2, and one at Node 5/Slot 12. The destination will be a drop card on Node 6.
- Step 9** Configure the test set for the test circuit type you created. For information about configuring your test set, consult your test set user guide.
- Step 10** Verify the integrity of all patch cables that will be used in this test by connecting the test set Tx connector to the test set Rx connector. Use appropriate attenuation; for more information, refer to the test set manual. If the test set does not run error-free, check the cable for damage and check the test set to make sure it is set up correctly before going to the next step.
- Step 11** Create a physical loopback at the circuit destination card:
- Attach one end of a patch cable to the destination port’s Tx connector.
 - Attach the other end to the port’s Rx connector.
- Step 12** At the circuit source card:
- Connect the Tx connector of the test set to the circuit Rx connector.
 - Connect the test set Rx connector to the circuit Tx connector.
- Step 13** Verify that the test set shows a clean signal. If a clean signal does not appear, repeat [Steps 6 through 12](#) to make sure the test set and cabling are configured correctly.
- Step 14** Inject BIT errors from the test set. To verify that you have a complete end-to-end circuit, verify that the errors appear at the test set.
- Step 15** From the View menu, choose **Go to Network View**.
- Step 16** Click one of the two spans leaving the circuit source node.
- Step 17** Complete the “[DLP-E40 Path Protection Switching Test](#)” task on page 16-56 to test the path protection switching function on this span.
- Step 18** In network view, click the other circuit source span and repeat [Step 17](#).
- Step 19** Set up and complete a BER test. Use the existing configuration and follow your site requirements for the length of time. Record the test results and configuration.
- Step 20** Complete the “[DLP-E163 Delete Circuits](#)” task on page 17-49 for the test circuit.
- Step 21** Remove any loopbacks, switches, or test sets from the nodes after all testing is complete.

- Step 22** Click the **Alarms** tab. Complete the following steps:
- Verify that the alarm filter is not on. See the “[DLP-E157 Disable Alarm Filtering](#)” task on page 17-46 for instructions.
 - Verify that no unexplained alarms appear on the network. If unexplained alarms appear, resolve them before continuing. Refer to the *Cisco ONS 15600 Troubleshooting Guide*.
 - Complete the “[DLP-E265 Export CTC Data](#)” task on page 18-84 to export alarm information.
- Step 23** Click the **Conditions** tab. Complete the following steps:
- Verify that no unexplained conditions appear on the network. If unexplained conditions appear, resolve them before continuing. Refer to the *Cisco ONS 15600 Troubleshooting Guide*.
 - Complete the “[DLP-E265 Export CTC Data](#)” task on page 18-84 to export condition data.
- Step 24** Repeat Steps 5 through 23 for each node that will be a source or destination for circuits traversing the third-party network.
- Step 25** If a node fails any test, repeat the test while verifying correct setup and configuration. If the test fails again, refer to the next level of support.
- After all tests are successfully completed and no alarms exist in the network, the network is ready for service application. Continue with Chapter 6, “[Create Circuits](#).”
- Stop. You have completed this procedure.
-

NTP-E86 Create a Logical Network Map

Purpose	This procedure positions nodes in the network view. This procedure allows a Superuser to create a consistent network view for all nodes on the network.
Tools	None
Prerequisite Procedures	NTP-E32 Verify Node Turn-Up , page 5-2
Required/As Needed	As needed
Onsite/Remote	Onsite or remote
Security Level	Superuser

- Step 1** Complete the “[DLP-E26 Log into CTC](#)” task on page 16-39. If you are already logged in, continue with [Step 2](#).
- Step 2** From the View menu, choose **Go To Network View**.
- Step 3** Change the position of the nodes in the network view according to your site plan. To do this:
- Press the **Ctrl** key while you drag and drop a node icon to a new location.
 - Deselect the previously selected node.
 - Repeat Step a for each node you need to position.
- Step 4** On the network view map, right-click and choose **Save Node Position**.
- Step 5** Click **Yes** in the **Save Node Position** dialog box.
- CTC displays a progress bar and saves the new node positions.



Note Nodes on the network map can be moved by users with Retrieve, Provisioning, and Maintenance security levels, but new network views can only be saved by a Superuser. To restore the view to a previously saved version of the network map, right-click on the network view map and choose **Reset Node Position**.

Stop. You have completed this procedure.
