



Common Control Cards

This chapter describes Cisco ONS 15454 common control card functions. For installation and turn-up procedures, refer to the *Cisco ONS 15454 Procedure Guide*.



Note

The terms "Unidirectional Path Switched Ring" and "UPSR" may appear in Cisco literature. These terms do not refer to using Cisco ONS 15xxx products in a unidirectional path switched ring configuration. Rather, these terms, as well as "Path Protected Mesh Network" and "PPMN," refer generally to Cisco's path protection feature, which may be used in any topological network configuration. Cisco does not recommend using its path protection feature in any particular topological network configuration.

Chapter topics include:

- [2.1 Common Control Card Overview, page 2-1](#)
- [2.2 TCC2 Card, page 2-7](#)
- [2.3 XC Card, page 2-12](#)
- [2.4 XCVT Card, page 2-14](#)
- [2.5 XC10G Card, page 2-18](#)
- [2.6 AIC Card, page 2-22](#)
- [2.7 AIC-I Card, page 2-26](#)

2.1 Common Control Card Overview

The card overview section summarizes card functions and compatibility.



Note

Each card is marked with a symbol that corresponds to a slot (or slots) on the ONS 15454 shelf assembly. The cards are then installed into slots displaying the same symbols. See the "[1.13.1 Card Slot Requirements](#)" section on [page 1-43](#) for a list of slots and symbols.

2.1.1 Common Control Cards

[Table 2-1](#) lists seven common control cards for the Cisco ONS 15454 and summarizes card functions.

Table 2-1 Common Control Card Functions

Card	Description	For Additional Information...
TCC2	The TCC2 is the main processing center for the ONS 15454 and provides system initialization, provisioning, alarm reporting, maintenance, and diagnostics. It has additional features including supply voltage monitoring, support for up to 84 data communication channel/generic communication channel (DCC/GCC) terminations, and an on-card lamp test.	See the “2.2 TCC2 Card” section on page 2-7.
XC	The XC card is the central element for switching; it establishes connections and performs time division switching (TDS).	See the “2.3 XC Card” section on page 2-12.
XCVT	The XCVT card is the central element for switching; it establishes connections and performs TDS. The XCVT can manage STS and VT circuits up to 48c.	See the “2.4 XCVT Card” section on page 2-14.
XC10G	The XC10G card is the central element for switching; it establishes connections and performs TDS. The XC10G can manage STS and VT circuits up to 192c. The XC10G allows up to four times the bandwidth of XC and XCVT cards.	See the “2.5 XC10G Card” section on page 2-18.
AIC	The AIC card provides customer-defined (environmental) alarms with its additional input/output alarm contact closures. It also provides orderwire.	See the “2.6 AIC Card” section on page 2-22.
AIC-I	The AIC-I card provides customer-defined (environmental) alarms with its additional input/output alarm contact closures. It also provides orderwire, user-data channels, and supply voltage monitoring.	See the “2.7 AIC-I Card” section on page 2-26.
AEP	The AEP board provides 48 dry alarm contacts: 32 inputs and 16 outputs. It can be used with the AIC-I card.	See the “1.9 Alarm Expansion Panel” section on page 1-30.

2.1.2 Card Compatibility

This sections lists ONS 15454 cards, compatible software versions, and compatible cross-connect cards. In the tables below, “Yes” means cards are compatible with the listed software versions and cross-connect cards. Table cells with dashes mean cards are not compatible with the listed software versions or cross-connect cards.

Table 2-2 lists the Cisco Transport Controller (CTC) software release compatibility for each common-control card.

Table 2-2 Common-Control Card Software Release Compatibility

Card	R2.2.1	R2.2.2	R3.0.1	R3.1	R3.2	R3.3	R3.4	R4.0	R4.1	R4.5	R4.6
TCC+	Yes	Yes	Yes	Yes	Yes	Yes	Yes	Yes	Yes	—	—
TCC2	—	—	—	—	—	—	—	Yes	Yes	Yes	Yes
XC	Yes	Yes	Yes	Yes	Yes	Yes	Yes	Yes	Yes	—	Yes
XCVT	Yes	Yes	Yes	Yes	Yes	Yes	Yes	Yes	Yes	Yes	Yes
XC10G	—	—	—	Yes	Yes	Yes	Yes	Yes	Yes	—	Yes
AIC	Yes	Yes	Yes	Yes	Yes	Yes	Yes	Yes	Yes	Yes	Yes
AIC-I	—	—	—	—	—	—	Yes	Yes	Yes	Yes	Yes
AEP	—	—	—	—	—	—	Yes	Yes	Yes	Yes	Yes

Table 2-3 lists the cross-connect card compatibility for each common-control card.

Table 2-3 Common-Control Card Cross-Connect Compatibility

Card	XC Card	XCVT Card	XC10G Card
TCC+	Yes	Yes	Yes
TCC2	Yes	Yes	Yes
XC	Yes	—	—
XCVT	—	Yes	—
XC10G	—	—	Yes ¹
AIC	Yes	Yes	Yes
AIC-I	Yes	Yes	Yes
AEP	Yes	Yes	Yes

1. The XC10G card requires a TCC+/TCC2 card, Software R3.1 or later, and the 15454-SA-ANSI or 15454-SA-HD shelf assembly to operate.

Table 2-4 lists the CTC software compatibility for each electrical card.

Table 2-4 Electrical Card Software Release Compatibility

Electrical Card	R2.2.1	R2.2.2	R3.0.1	R3.1	R3.2	R3.3	R3.4	R4.0	R4.1	R4.5	R4.6
EC1-12	Yes	Yes	Yes	Yes	Yes	Yes	Yes	Yes	Yes	—	Yes
DS1-14	Yes	Yes	Yes	Yes	Yes	Yes	Yes	Yes	Yes	—	Yes
DS1N-14	Yes	Yes	Yes	Yes	Yes	Yes	Yes	Yes	Yes	—	Yes
DS3-12	Yes	Yes	Yes	Yes	Yes	Yes	Yes	Yes	Yes	—	Yes
DS3N-12	Yes	Yes	Yes	Yes	Yes	Yes	Yes	Yes	Yes	—	Yes

Table 2-4 Electrical Card Software Release Compatibility (continued)

Electrical Card	R2.2.1	R2.2.2	R3.0.1	R3.1	R3.2	R3.3	R3.4	R4.0	R4.1	R4.5	R4.6
DS3-12E	—	Yes ¹	Yes	Yes	Yes	Yes	Yes	Yes	Yes	—	Yes
DS3N-12E	—	Yes ¹	Yes	Yes	Yes	Yes	Yes	Yes	Yes	—	Yes
DS3XM-6 (Transmux)	Yes	Yes	Yes	Yes	Yes	Yes	Yes	Yes	Yes	—	Yes
DS3i-N-12	—	—	—	—	—	—	—	—	Yes (4.1.2)	—	Yes

1. Use Software R3.0 or later to enable all enhanced performance monitoring functions on the DS-3E cards. With Software R2.2.2, the DS-3E cards operate as the older DS-3 cards without enhanced performance monitoring.

Table 2-5 lists the cross-connect card compatibility for each electrical card.

Table 2-5 Electrical Card Cross-Connect Compatibility

Electrical Card	XC Card	XCVT Card	XC10G Card ¹
EC1-12	Yes	Yes	Yes
DS1-14	Yes	Yes	Yes
DS1N-14	Yes	Yes	Yes
DS3-12	Yes	Yes	Yes
DS3N-12	Yes	Yes	Yes
DS3-12E	Yes	Yes	Yes
DS3N-12E	Yes	Yes	Yes
DS3XM-6 (Transmux)	Yes	Yes	Yes
DS3i-N-12	No	Yes	Yes

1. The XC10G card requires a TCC2 card, Software R3.1 or later, and the 15454-SA-ANSI or 154545-SA-HD shelf assembly to operate.

Table 2-6 lists the CTC software compatibility for each optical card.

Table 2-6 Optical Card Software Release Compatibility

Optical Card	R2.2.1	R2.2.2	R3.0.1	R3.1	R3.2	R3.3	R3.4	R4.0	R4.1	R4.5	R4.6
OC3 IR 4 1310	Yes	Yes	Yes	Yes	Yes	Yes	Yes	Yes	Yes	—	Yes
OC3 IR 4/STM1 SH 1310	Yes	Yes	Yes	Yes	Yes	Yes	Yes	Yes	Yes	—	Yes
OC3 IR /STM1 SH 1310-8	—	—	—	—	—	—	—	Yes	Yes	—	Yes
OC12 IR/STM4 SH 1310	Yes	Yes	Yes	Yes	Yes	Yes	Yes	Yes	Yes	—	Yes
OC12 IR 1310	Yes	Yes	Yes	Yes	Yes	Yes	Yes	Yes	Yes	—	Yes

Table 2-6 Optical Card Software Release Compatibility (continued)

Optical Card	R2.2.1	R2.2.2	R3.0.1	R3.1	R3.2	R3.3	R3.4	R4.0	R4.1	R4.5	R4.6
OC12 LR 1310	Yes	Yes	Yes	Yes	Yes	Yes	Yes	Yes	Yes	—	Yes
OC12 LR 1550	Yes	Yes	Yes	Yes	Yes	Yes	Yes	Yes	Yes	—	Yes
OC12 LR/STM4 LH 1310	Yes	Yes	Yes	Yes	Yes	Yes	Yes	Yes	Yes	—	Yes
OC12 LR/STM4 LH 1550	Yes	Yes	Yes	Yes	Yes	Yes	Yes	Yes	Yes	—	Yes
OC12 IR/STM4 SH 1310-4	—	—	—	—	—	Yes	Yes	Yes	Yes	—	Yes
OC48 IR 1310	Yes	Yes	Yes	Yes	Yes	Yes	Yes	Yes	Yes	—	Yes
OC48 LR 1550	Yes	Yes	Yes	Yes	Yes	Yes	Yes	Yes	Yes	—	Yes
OC48 IR/STM16 SH AS 1310 ¹	—	—	—	Yes	Yes	Yes	Yes	Yes	Yes	—	Yes
OC48 LR/STM16 LH AS 1550 ²	—	—	—	Yes	Yes	Yes	Yes	Yes	Yes	—	Yes
OC48 ELR/STM16 EH 100 GHz	Yes	Yes	Yes	Yes	Yes	Yes	Yes	Yes	Yes	—	Yes
OC48 ELR 200 GHz	Yes	Yes	Yes	Yes	Yes	Yes	Yes	Yes	Yes	—	Yes
OC192 SR/STM64 IO 1310	—	—	—	—	—	—	—	Yes	Yes	—	Yes
OC192 IR/STM64 SH 1550	—	—	—	—	—	—	—	Yes	Yes	—	Yes
OC192 LR/STM64 LH 1550	—	—	—	Yes	Yes	Yes	Yes	Yes	Yes	—	Yes
OC192 LR/STM64 LH ITU 15xx.xx	—	—	—	—	—	—	—	Yes	Yes	—	Yes
TXP_MR_10G	—	—	—	—	—	—	—	Yes	Yes	Yes	Yes
MXP_2.5G_10G	—	—	—	—	—	—	—	Yes	Yes	Yes	Yes
TXP_MR_2.5G	—	—	—	—	—	—	—	Yes	Yes	Yes	Yes
TXPP_MR_2.5G	—	—	—	—	—	—	—	Yes	Yes	Yes	Yes
FC_MR-4 ³	—	—	—	—	—	—	—	—	—	—	Yes

1. To enable OC-192 and OC-48 any-slot card operation, use the XC10G card, the TCC+/TCC2 card, Software R3.1 or later, and the 15454-SA-ANSI or 154545-SA-HD shelf assembly. Do not pair an XC or XCVT with an XC10G.
2. To enable OC-192 and OC-48 any-slot card operation, use the XC10G card, the TCC+/TCC2 card, Software R3.1 or later, and the 15454-SA-ANSI or 154545-SA-HD shelf assembly. Do not pair an XC or XCVT with an XC10G.
3. The FC_MR-4 card requires an XC10G card; it is not compatible with the XC or XCVT.

Table 2-7 lists the cross-connect card compatibility for each optical card.

Table 2-7 Optical Card Cross-Connect Compatibility

Optical Card	XC Card	XCVT Card	XC10G Card ¹
OC3 IR 4 1310	Yes	Yes	Yes
OC3 IR 4/STM1 SH 1310	Yes	Yes	Yes

Table 2-7 Optical Card Cross-Connect Compatibility (continued)

Optical Card	XC Card	XCVT Card	XC10G Card ¹
OC3 IR /STM1SH 1310-8	—	—	Yes
OC12 IR 1310	Yes	Yes	Yes
OC12 LR 1310	Yes	Yes	Yes
OC12 LR 1550	Yes	Yes	Yes
OC12 IR/STM4 SH 1310	Yes	Yes	Yes
OC12 LR/STM4 LH 1310	Yes	Yes	Yes
OC12 LR/STM4 LH 1550	Yes	Yes	Yes
OC12 IR/STM4 SH 1310-4	—	—	Yes
OC48 IR 1310	Yes	Yes	Yes
OC48 LR 1550	Yes	Yes	Yes
OC48 IR/STM16 SH AS 1310	Yes (R3.2 and later in Slots 5, 6, 12, 13)	Yes (R3.2 and later in Slots 5, 6, 12, 13)	Yes
OC48 LR/STM16 LH AS 1550	Yes (R3.2 and later in Slots 5, 6, 12, 13)	Yes (R3.2 and later in Slots 5, 6, 12, 13)	Yes
OC48 ELR/STM16 EH 100 GHz	Yes	Yes	Yes
OC48 ELR 200 GHz	Yes	Yes	Yes
OC192 SR/STM64 IO 1310	—	—	Yes
OC192 IR/STM64 SH 1550	—	—	Yes
OC192 LR/STM64 LH 1550	—	—	Yes
OC192 LR/STM64 LH ITU 15xx.xx	—	—	Yes
TXP_MR_10G	Yes	Yes	Yes
MXP_2.5G_10G	Yes	Yes	Yes
TXP_MR_2.5G	Yes	Yes	Yes
TXPP_MR_2.5G	Yes	Yes	Yes
FC_MR_4	—	Yes (only in trunk slots, for operation in Fiber Channel mode only)	Yes

1. The XC10G card requires a TCC+/TCC2 card, Software R3.1 or later, and the 15454-SA-ANSI or 15454-SA-HD shelf assembly to operate.

Table 2-8 lists the CTC software compatibility for each Ethernet card.

Table 2-8 Ethernet Card Software Compatibility

Ethernet Cards	R2.2.1	R2.2.2	R3.0.1	R3.1	R3.2	R3.3	R3.4	R4.0	R4.1	R4.5	R4.6
E100T-12	Yes	Yes	Yes	Yes	Yes	Yes	Yes	Yes	Yes	—	Yes
E1000-2	Yes	Yes	Yes	Yes	Yes	Yes	Yes	Yes	Yes	—	Yes
E100T-G	Yes	Yes	Yes	Yes	Yes	Yes	Yes	Yes	Yes	—	Yes

Table 2-8 Ethernet Card Software Compatibility (continued)

Ethernet Cards	R2.2.1	R2.2.2	R3.0.1	R3.1	R3.2	R3.3	R3.4	R4.0	R4.1	R4.5	R4.6
E1000-2-G	Yes	Yes	Yes	Yes	Yes	Yes	Yes	Yes	Yes	—	Yes
G1000-4	—	—	—	—	Yes	Yes	Yes	Yes	Yes	—	Yes
G1K-4	—	—	—	—	Yes	Yes	Yes	Yes	Yes	—	Yes
ML100T-12	—	—	—	—	—	—	—	Yes	Yes	—	Yes
ML1000-2	—	—	—	—	—	—	—	Yes	Yes	—	Yes

Table 2-9 lists the cross-connect card compatibility for each Ethernet card.

Table 2-9 Ethernet Card Cross-Connect Compatibility

Ethernet Cards	XC Card	XCVT Card	XC10G Card ¹
E100T-12	Yes	Yes	—
E1000-2	Yes	Yes	—
E100T-G	Yes	Yes	Yes
E1000-2-G	Yes	Yes	Yes
G1000-4	—	—	Yes
G1K-4	Yes, in Slots 5, 6, 12, 13	Yes, in Slots 5, 6, 12, 13	Yes
ML100T-12	Yes, in Slots 5, 6, 12, 13	Yes, in Slots 5, 6, 12, 13	Yes
ML1000-2	Yes, in Slots 5, 6, 12, 13	Yes, in Slots 5, 6, 12, 13	Yes

1. The XC10G card requires a TCC+/TCC2 card, Software R3.1 or later and the 15454-SA-ANSI or 154545-SA-HD shelf assembly to operate.

DWDM cards are compatible with Software R4.5 and 4.6. In Software R4.5, DWDM cards are not compatible with XC, XCVT, or XC10G cards.

2.2 TCC2 Card

The Advanced Timing Communications and Control (TCC2) card performs system initialization, provisioning, alarm reporting, maintenance, diagnostics, IP address detection/resolution, SONET section overhead (SOH) data communication channel/generic communication channel (DCC/GCC) termination, and system fault detection for the ONS 15454. The TCC2 also ensures that the system maintains Stratum 3 (Telcordia GR-253-CORE) timing requirements. It monitors the supply voltage of the system.



Note

The TCC2 card requires Software Release 4.0.0 or later.

**Note**

The LAN interface of the TCC2 card meets the standard Ethernet specifications by supporting a cable length of 328 ft (100 m) at temperatures from 32 to 149 degrees Fahrenheit (0 to 65 degrees Celsius). The interfaces can operate with a cable length of 32.8 ft (10 m) maximum at temperatures from -40 to 32 degrees Fahrenheit (-40 to 0 degrees Celsius).

Figure 2-1 shows the TCC2 faceplate.

Figure 2-1 TCC2 Faceplate

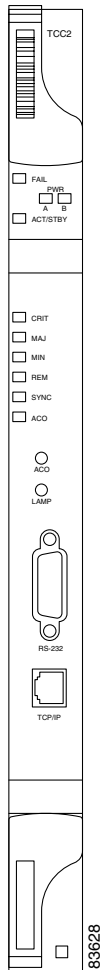
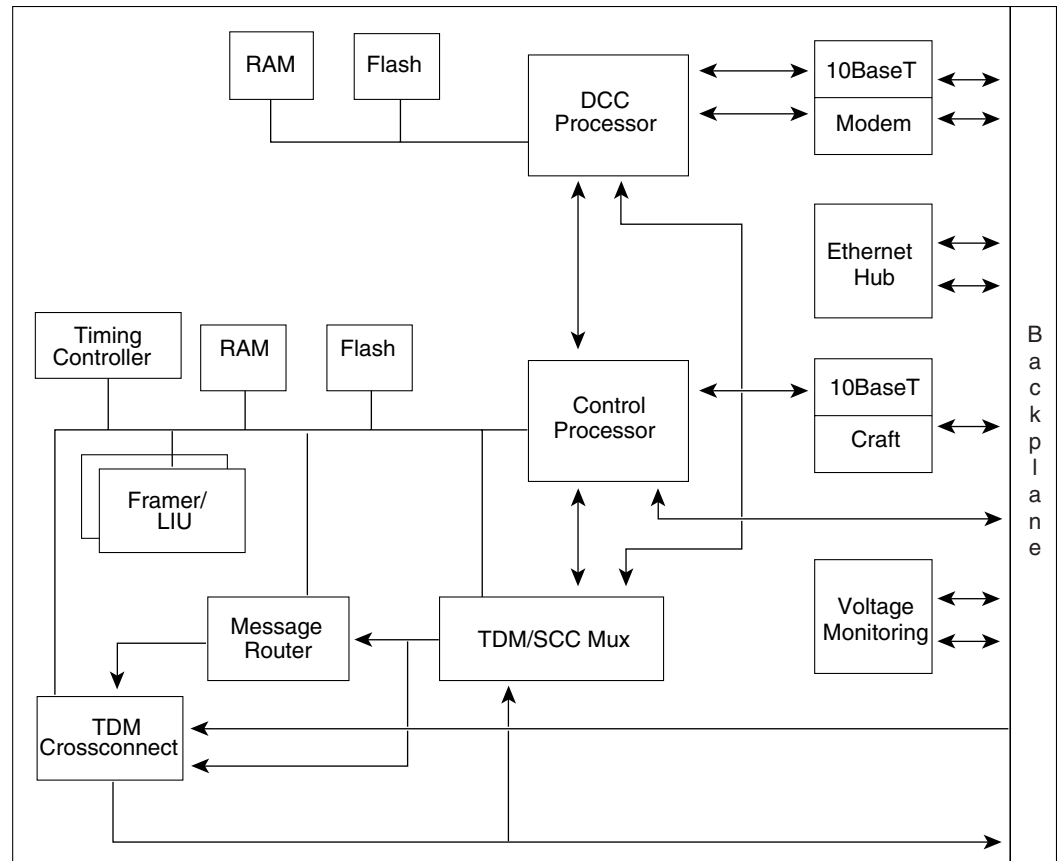

Figure 2-2 shows a block diagram of the card.

Figure 2-2 TCC2 Block Diagram



2.2.1 TCC2 Functionality

The TCC2 card supports multichannel, high-level data link control (HDLC) processing for the DCC. Up to 32 DCCs can be routed over the TCC2 card and up to 32 DCCs can be terminated at the TCC2 card (subject to the available optical digital communication channels). The TCC2 selects and processes 32 DCCs to facilitate remote system management interfaces. The TCC2 hardware is prepared for 84 DCCs, which will be available in a future software release.

The TCC2 also originates and terminates a cell bus carried over the module. The cell bus supports links between any two cards in the node, which is essential for peer-to-peer communication. Peer-to-peer communication accelerates protection switching for redundant cards.

The node database, IP address, and system software are stored in TCC2 nonvolatile memory, which allows quick recovery in the event of a power or card failure.

The TCC2 performs all system-timing functions for each ONS 15454. The TCC2 monitors the recovered clocks from each traffic card and two BITS ports for frequency accuracy. The TCC2 selects a recovered clock, a BITS, or an internal Stratum 3 reference as the system-timing reference. You can provision any of the clock inputs as primary or secondary timing sources. A slow-reference tracking loop allows the TCC2 to synchronize with the recovered clock, which provides holdover if the reference is lost.

The TCC2 monitors both supply voltage inputs on the shelf. An alarm is generated if one of the supply voltage inputs has a voltage out of the specified range.

Install TCC2 cards in Slots 7 and 11 for redundancy. If the active TCC2 fails, traffic switches to the protect TCC2. All TCC2 protection switches conform to protection switching standards when the bit error rate (BER) counts are not in excess of $1 * 10^{exp - 3}$ and completion time is less than 50 ms.

The TCC2 card has two built-in interface ports for accessing the system: an RJ-45 10baseT LAN interface and an EIA/TIA-232 ASCII interface for local craft access. It also has a 10baseT LAN port for user interfaces via the backplane.

**Note**

Cisco does not support operation of the ONS 15454 with only one TCC2 card. For full functionality and to safeguard your system, always operate with two TCC2 cards.

**Note**

When a second TCC2 card is inserted into a node, it synchronizes its software, its backup software, and its database with the active TCC2. If the software version of the new TCC2 does not match the version on the active TCC2, the newly inserted TCC2 copies from the active TCC2, taking about 15 to 20 minutes to complete. If the backup software version on the new TCC2 does not match the version on the active TCC2, the newly inserted TCC2 copies the backup software from the active TCC2 again, taking about 15 to 20 minutes. Copying the database from the active TCC2 takes about 3 minutes. Depending on the software version and backup version the new TCC2 started with, the entire process can take between 3 and 40 minutes.

2.2.2 TCC2 Card-Level Indicators

The TCC2 faceplate has eight LEDs. [Table 2-10](#) describes the two card-level LEDs on the TCC2 faceplate.

Table 2-10 TCC2 Card-Level Indicators

Card-Level LEDs	Definition
Red FAIL LED	This LED is on during reset. The FAIL LED flashes during the boot and write process. Replace the card if the FAIL LED persists.
ACT/STBY LED Green (Active) Yellow (Standby)	Indicates the TCC2 is active (green) or in standby (yellow) mode. The ACT/STBY LED also provides the timing reference and shelf control. When the active TCC2 is writing to its database or to the standby TCC2 database, the card LEDs blink. To avoid memory corruption, do not remove the TCC2 when the active or standby LED is blinking.

2.2.3 Network-Level Indicators

[Table 2-11](#) describes the six network-level LEDs on the TCC2 faceplate.

Table 2-11 TCC2 Network-Level Indicators

System-Level LEDs	Definition
Red CRIT LED	Indicates critical alarms in the network at the local terminal.
Red MAJ LED	Indicates major alarms in the network at the local terminal.
Yellow MIN LED	Indicates a minor alarm in the network at the local terminal.

Table 2-11 TCC2 Network-Level Indicators (continued)

System-Level LEDs	Definition
Red REM LED	Provides first-level alarm isolation. The remote (REM) LED turns red when an alarm is present in one or more of the remote terminals.
Green SYNC LED	Indicates that node timing is synchronized to an external reference.
Green ACO LED	After pressing the ACO button, the ACO LED turns green. The ACO button opens the audible alarm closure on the backplane. ACO is stopped if a new alarm occurs. After the originating alarm is cleared, the ACO LED and audible alarm control are reset.

2.2.4 TCC2 Card Specifications

The TCC2 card has the following specifications:

- CTC software
 - Interface: EIA/TIA-232 (local craft access, on TCC2 faceplate)
 - Interface: 10baseT LAN (on TCC2 faceplate)
 - Interface: 10baseT LAN (via backplane)
- Synchronization
 - Stratum 3, per Telcordia GR-253-CORE
 - Free running access: Accuracy +/- 4.6 ppm
 - Holdover stability: $3.7 * 10 \text{ exp} - 7$ per day including temperature (< 255 slips in first 24 hours)
 - Reference: External BITS, line, internal
- Supply voltage monitoring
 - Both supply voltage inputs are monitored.
 - Normal operation: -40.5 to -56.7 V
 - Undervoltage: Major alarm
 - Overvoltage: Major alarm
- Environmental
 - Operating temperature: -40 to +149 degrees Fahrenheit (-40 to +65 degrees Celsius)
 - Operating humidity: 5 to 95%, noncondensing
 - Power consumption: 26.00 W, 0.54 A at -48 V, 88.8 BTU/hr
- Dimensions
 - Height: 12.650 in. (321.3 mm)
 - Width: 0.716 in. (18.2 mm)
 - Depth: 9.000 in. (228.6 mm)
 - Depth with backplane connector: 235 mm (9.250 in.)
 - Weight not including clam shell: 0.7 kg (1.5 lb)

- Compliance: For compliance information, refer to the *Cisco Optical Transport Products Safety and Compliance Information*.

2.3 XC Card

The cross-connect (XC) card is the central element for ONS 15454 switching. Available cross-connect cards are the XC, XCVT, and XC10G cards. The XC establishes connections and performs time division switching (TDS) at the STS-1 level between ONS 15454 traffic cards. [Figure 2-3](#) shows the XC card faceplate and block diagram.

Figure 2-3 XC Card Faceplate and Block Diagram

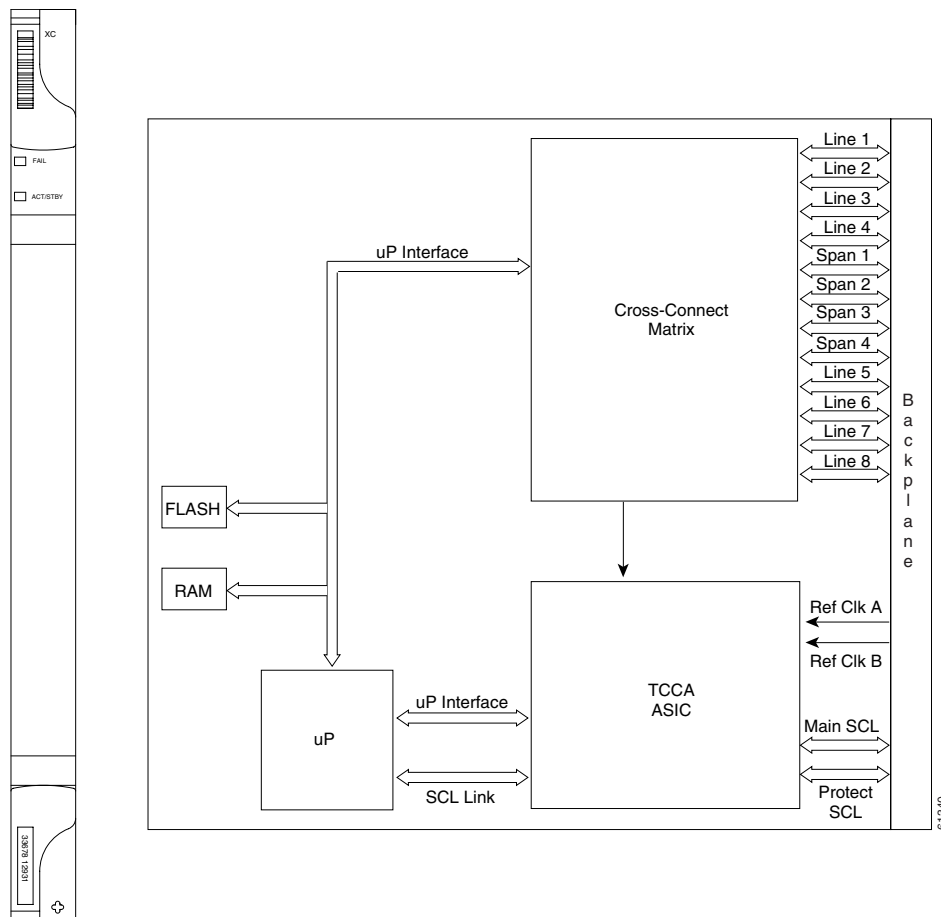

2.3.1 XC Functionality

The switch matrix on the XC card consists of 288 bidirectional ports ([Figure 2-4](#)). When creating bidirectional STS-1 cross-connects, each cross-connect uses two STS-1 ports. This results in 144 bidirectional STS-1 cross-connects. The switch matrix is fully crosspoint and broadcast supporting. Any

STS-1 on any port can be connected to any other port, meaning that the STS cross-connections are nonblocking. Network operators can concentrate or groom low-speed traffic from traffic cards onto high-speed transport spans and drop low-speed traffic from transport spans onto traffic cards.

Figure 2-4 XC Cross-Connect Matrix

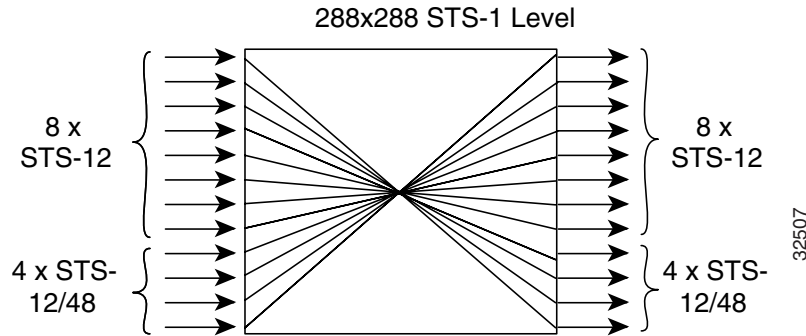

The XC card has 12 input ports and 12 output ports. Four input and output ports operate at either STS-12 or STS-48 rates. The remaining eight input and output ports operate at the STS-12 rate. An STS-1 on any of the input ports can be mapped to an STS-1 output port, thus providing full STS-1 time slot assignments (TSA).

The XC card works with the TCC2 card to maintain connections and set up cross-connects within the ONS 15454. The XC, XCVT, or XC10G is required to operate the ONS 15454. You establish cross-connect and provisioning information through CTC. The TCC2 establishes the proper internal cross-connect information and relays the setup information to the cross-connect card.



Caution

Do not operate the ONS 15454 with only one XC, XCVT, or XC10G card. Two cross-connect cards of the same type (either two XC, two XCVT, or two XC10G cards) must always be installed.

The card has no external interfaces. All cross-connect card interfaces are provided through the ONS 15454 backplane.

2.3.2 XC Card-Level Indicators

Table 2-12 describes the two card-level LEDs on the XC faceplate.

Table 2-12 XC Card-Level Indicators

Card-Level Indicators	Definition
Red FAIL LED	Indicates that the card's processor is not ready. If the FAIL LED persists, replace the card.
ACT/STBY LED Green (Active) Amber (Standby)	Indicates whether the XC card is active and carrying traffic (green) or in standby mode as a protect card (amber).

2.3.3 XC Card Specifications

The XC card has the following specifications:

- Cross-connect functionality
 - Connection setup time: 5 ms
 - Latency: 270 ns
- Environmental
 - Operating temperature:
 - C-Temp (15454-XC): 32 to 131 degrees Fahrenheit (0 to +55 degrees Celsius)
 - I-Temp (15454-XC-T): –40 to 149 degrees Fahrenheit (–40 to +65 degrees Celsius)
 - Operating humidity: 5 to 95%, noncondensing
 - Power consumption: 29 W, 0.6 A, 99 BTU/hr
- Dimensions
 - Height: 12.650 in. (321.3 mm)
 - Width: 0.716 in. (18.2 mm)
 - Depth: 9.000 in. (228.6 mm)
 - Card weight: 1.5 lb (0.7 kg)
- Compliance
 - For compliance information, refer to the *Cisco Optical Transport Products Safety and Compliance Information*.

2.4 XCVT Card

The XCVT card provides the same STS capability as a standard XC card and also provides VT cross-connection. The XCVT provides nonblocking STS-48 capacity to Slots 5, 6, 12, and 13, and nonbidirectional blocking STS-12 capacity to Slots 1 to 5 and 14 to 17. Any STS-1 on any port can be connected to any other port, meaning that the STS cross-connections are nonblocking.

[Figure 2-5](#) shows the XCVT faceplate and block diagram.

Figure 2-5 XCVT Faceplate and Block Diagram

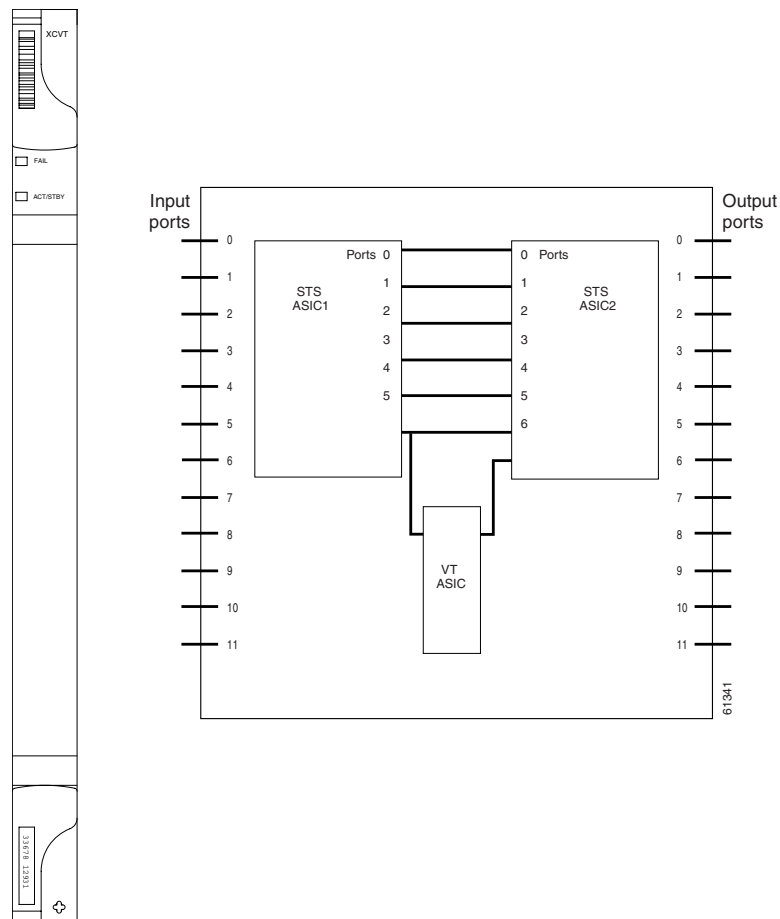

2.4.1 XCVT Functionality

The STS-1 switch matrix on the XCVT card consists of 288 bidirectional ports and adds a VT matrix that can manage up to 336 bidirectional VT1.5 ports or the equivalent of a bidirectional STS-12. The VT1.5-level signals can be cross connected, dropped, or rearranged. The TCC2 assigns bandwidth to each slot on a per STS-1 or per VT1.5 basis. The switch matrices are fully crosspoint and broadcast supporting.

The XCVT card provides:

- 288 STS bidirectional ports
- 144 STS bidirectional cross-connects
- 672 VT1.5 ports via 24 logical STS ports
- 336 VT1.5 bidirectional cross-connects
- Nonblocking at the STS level
- STS-1/3c/6c/12c/48c cross-connects

The XCVT card works with the TCC2 card to maintain connections and set up cross-connects within the node. The XCVT, XC10G, or XC is required to operate the ONS 15454. You can establish cross-connect (circuit) information through CTC. The TCC2 establishes the proper internal cross-connect information and relays the setup information to the XCVT card.

**Caution**

Do not operate the ONS 15454 with only one XC, XCVT, or XC10G card. Two cross-connect cards of the same type (either two XC, two XCVT, or two XC10G cards) must always be installed.

Figure 2-6 shows the cross-connect matrix.

Figure 2-6 XCVT Cross-Connect Matrix

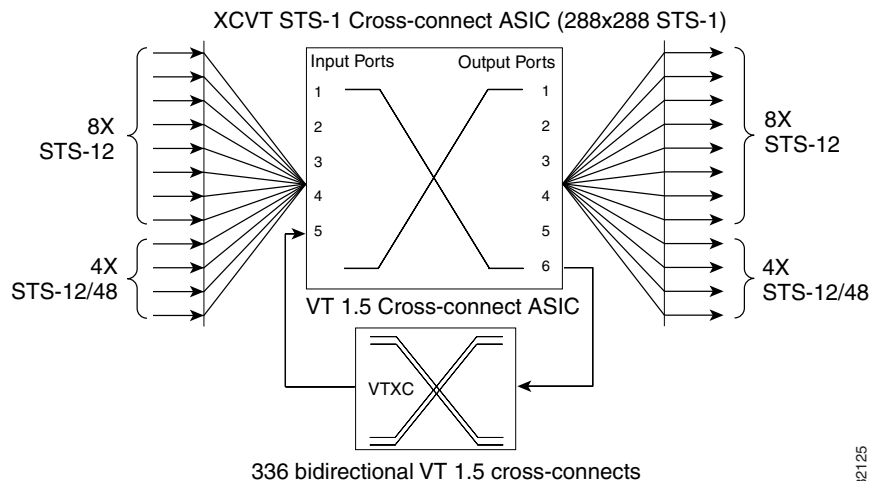

2.4.2 VT Mapping

The VT structure is designed to transport and switch payloads below the DS-3 rate. The ONS 15454 performs Virtual Tributary (VT) mapping according to Telcordia GR-253-CORE standards. Table 2-13 shows the VT numbering scheme for the ONS 15454 as it relates to the Telcordia standard.

Table 2-13 VT Mapping

ONS 15454 VT Number	Telcordia Group/VT Number
VT1	Group1/VT1
VT2	Group2/VT1
VT3	Group3/VT1
VT4	Group4/VT1
VT5	Group5/VT1
VT6	Group6/VT1
VT7	Group7/VT1
VT8	Group1/VT2
VT9	Group2/VT2

Table 2-13 VT Mapping (continued)

ONS 15454 VT Number	Telcordia Group/VT Number
VT10	Group3/VT2
VT11	Group4/VT2
VT12	Group5/VT2
VT13	Group6/VT2
VT14	Group7/VT2
VT15	Group1/VT3
VT16	Group2/VT3
VT17	Group3/VT3
VT18	Group4/VT3
VT19	Group5/VT3
VT20	Group6/VT3
VT21	Group7/VT3
VT22	Group1/VT4
VT23	Group2/VT4
VT24	Group3/VT4
VT25	Group4/VT4
VT26	Group5/VT4
VT27	Group6/VT4
VT28	Group7/VT4

2.4.3 XCVT Hosting DS3XM-6

A single DS3XM-6 can demultiplex (map down to a lower rate) six DS-3 signals into 168 VT1.5s that the XCVT card manages and cross connects. XCVT cards host a maximum of 336 bidirectional VT1.5s. In most network configurations, two DS3XM-6 cards are paired as working and protect cards.

2.4.4 XCVT Card-Level Indicators

Table 2-14 shows the two card-level LEDs on the XCVT card faceplate.

Table 2-14 XCVT Card-Level Indicators

Card-Level Indicators	Definition
Red FAIL LED	Indicates that the card's processor is not ready. Replace the card if the red FAIL LED persists.
ACT/STBY LED Green (Active) Amber (Standby)	Indicates whether the XCVT card is active and carrying traffic (green) or in standby mode to the active XCVT card (amber).

2.4.5 XC/XCVT Compatibility

The XCVT card is compatible with the XC cards. The XCVT card supports run-time compatibility with the XC cross-connect both within a single node and within a ring of mixed XCVT and XC nodes. However, working and protect cards within a single ONS 15454 must be either two XC cards or two XCVT cards.

The XC and XCVT cards are supported in path protection and bidirectional line switched ring (BLSR) configurations. VT and STS-level cross-connect and protection management are also supported in either type of ring. Nodes that rearrange or drop VTs must use an XCVT. Nodes that only rearrange or drop STSs can use an XC. You do not need to upgrade STS-only nodes to XCVT in a ring that can handle both VT and STS drop/rearrangement.

When upgrading from XC to XCVT cards, the first XCVT card installed acts as an XC card until the second XCVT card is installed.

2.4.6 XCVT Card Specifications

The XCVT card has the following specifications:

- Environmental
 - Operating temperature:
 - C-Temp (15454-XC-VT): 32 to 131 degrees Fahrenheit (0 to +55 degrees Celsius)
 - I-Temp (15454-XC-VT-T): –40 to 149 degrees Fahrenheit (–40 to +65 degrees Celsius)
 - Operating humidity: 5 to 95%, noncondensing
 - Power consumption: 34.40 W, 0.72 A, 117.46 BTU/hr
- Dimensions
 - Height: 12.650 in. (321.3 mm)
 - Width: 0.716 in. (18.2 mm)
 - Depth: 9.000 in. (228.6 mm)
 - Card weight: 1.9 lb (0.8 kg)
- Compliance
 - For compliance information, refer to the *Cisco Optical Transport Products Safety and Compliance Information*.

2.5 XC10G Card

The XC10G card cross connects STS-12, STS-48, and STS-192 signal rates. The XC10G allows up to four times the bandwidth of the XC and XCVT cards. The XC10G provides a maximum of 576 STS-1 cross-connections through 1152 STS-1 ports. Any STS-1 on any port can be connected to any other port, meaning that the STS cross-connections are nonblocking.

Figure 2-7 shows the XC10G faceplate and block diagram.

Figure 2-7 XC10G Faceplate and Block Diagram

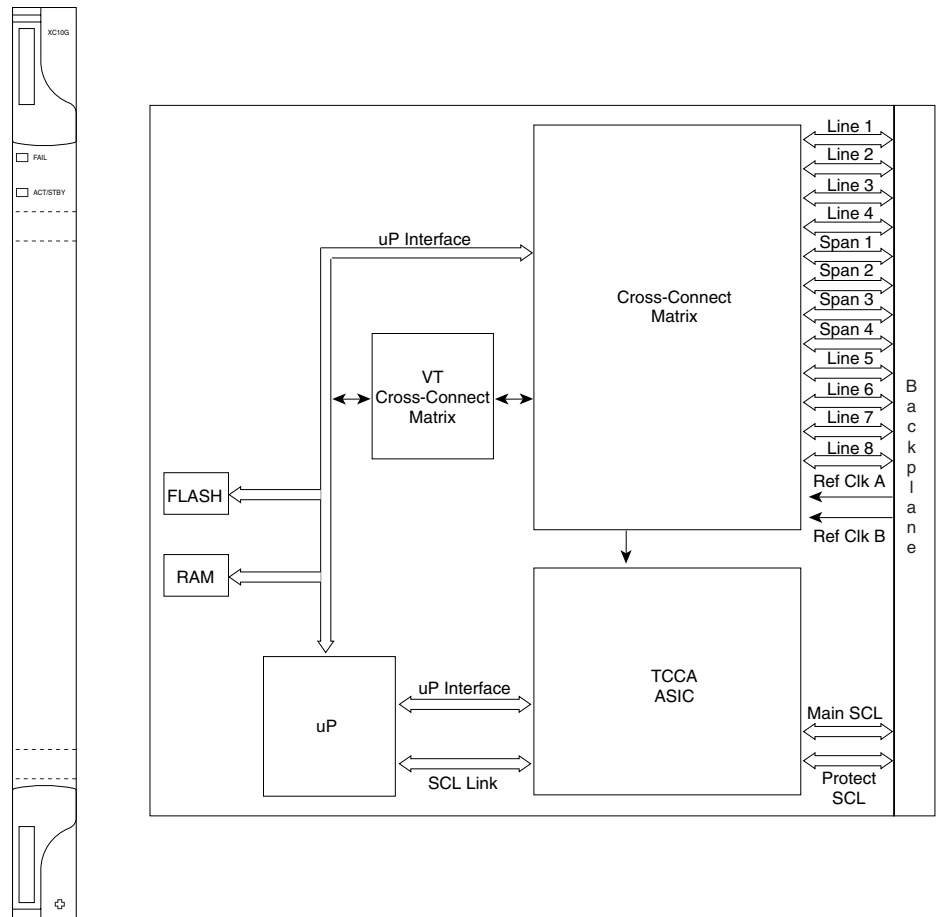

2.5.1 XC10G Functionality

The XC10G card manages up to 672 bidirectional VT1.5 ports and 1152 bidirectional STS-1 ports. The TCC2 assigns bandwidth to each slot on a per STS-1 or per VT1.5 basis.

The XC10G, XCVT, or XC is required to operate the ONS 15454. You can establish cross-connect (circuit) information through the Cisco Transport Controller (CTC). The TCC2 establishes the proper internal cross-connect information and sends the setup information to the cross-connect card.

The XC10G card provides:

- 1152 STS bidirectional ports
- 576 STS bidirectional cross-connects
- 672 VT1.5 ports via 24 logical STS ports
- 336 VT1.5 bidirectional cross-connects
- Nonblocking at STS level
- STS-1/3c/6c/12c/48c/192c cross-connects

**Caution**

Do not operate the ONS 15454 with only one XC, XCVT, or XC10G card. Two cross-connect cards of the same type (either two XC, two XCVT, or two XC10G cards) must always be installed.

Figure 2-8 shows the cross-connect matrix.

Figure 2-8 XC10G Cross-Connect Matrix

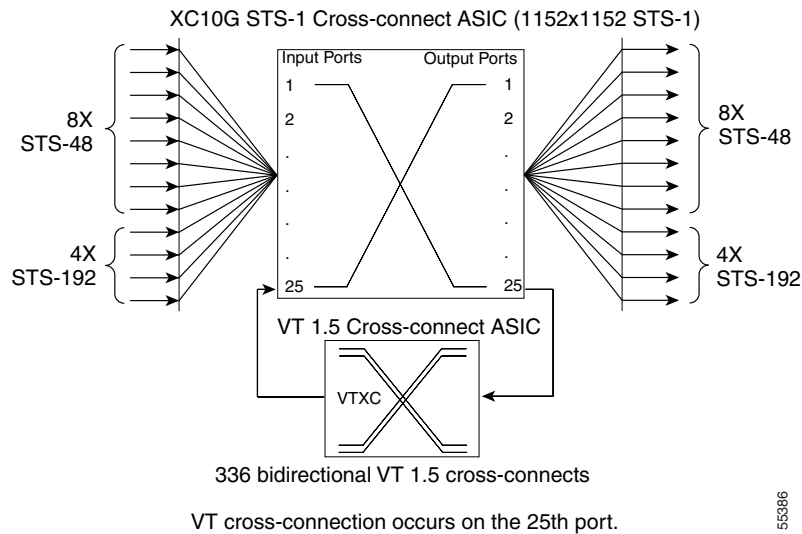

2.5.2 VT Mapping

The VT structure is designed to transport and switch payloads below the DS-3 rate. The ONS 15454 performs VT mapping according to Telcordia GR-253-CORE standards. Table 2-15 shows the VT numbering scheme for the ONS 15454 as it relates to the Telcordia standard.

Table 2-15 VT Mapping

ONS 15454 VT Number	Telcordia Group/VT Number
VT1	Group1/VT1
VT2	Group2/VT1
VT3	Group3/VT1
VT4	Group4/VT1
VT5	Group5/VT1
VT6	Group6/VT1
VT7	Group7/VT1
VT8	Group1/VT2
VT9	Group2/VT2
VT10	Group3/VT2
VT11	Group4/VT2

Table 2-15 VT Mapping (continued)

ONS 15454 VT Number	Telcordia Group/VT Number
VT12	Group5/VT2
VT13	Group6/VT2
VT14	Group7/VT2
VT15	Group1/VT3
VT16	Group2/VT3
VT17	Group3/VT3
VT18	Group4/VT3
VT19	Group5/VT3
VT20	Group6/VT3
VT21	Group7/VT3
VT22	Group1/VT4
VT23	Group2/VT4
VT24	Group3/VT4
VT25	Group4/VT4
VT26	Group5/VT4
VT27	Group6/VT4
VT28	Group7/VT4

2.5.3 XC10G Hosting DS3XM-6

A single DS3XM-6 can demultiplex (map down to a lower rate) six DS-3 signals into 168 VT1.5s that the XC10G card manages and cross connects. XC10G cards host a maximum of 336 bidirectional VT1.5 ports. In most network configurations two DS3XM-6 cards are paired as working and protect cards.

2.5.4 XC10G Card-Level Indicators

[Table 2-16](#) describes the two card-level LEDs on the XC10G faceplate.

Table 2-16 XC10G Card-Level Indicators

Card-Level Indicators	Definition
Red FAIL LED	Indicates that the card's processor is not ready. This LED illuminates during reset. The FAIL LED flashes during the boot process. Replace the card if the red FAIL LED persists.
ACT/STBY LED Green (Active) Amber (Standby)	Indicates whether the XC10G is active and carrying traffic (green), or in standby mode to the active XC10G card (amber).

2.5.5 XC/XCVT/XC10G Compatibility

The XC10G supports the same features as the XC and XCVT cards. The XC10G card is required for OC-192 operation and OC-48 any-slot operation. Do not use the XCVT or XC cards if you are using the OC-192 card, or if you install an OC-48 any-slot cards in Slots 1 to 4 or 14 to 17.



Note

A configuration mismatch alarm occurs when an XC or XCVT cross-connect card co-exists with an OC-192 card placed in Slots 5, 6, 12, or 13, or with an OC-48 card placed in Slots 1 to 4 or 14 to 17.

The TCC2 card, Software R3.1 or later, and the 15454-SA-ANSI or 15454-SA-HD shelf assembly are required for the operation of the XC10G. If you are using Ethernet cards, the E1000-2-G or the E100T-G must be used when the XC10G cross-connect card is in use. Do not pair an XC or XCVT with an XC10G. When upgrading from XC or XCVT to the XC10G card, refer to the *Cisco ONS 15454 Procedure Guide* for more information.

The upgrade procedure from the XC/XCVT cards to the XC10G card only applies to XC/XCVT cards that are installed in the 15454-SA-ANSI or 15454-SA-HD (Software R3.1 and later). You cannot perform this upgrade from shelves released prior to Software R3.1.

2.5.6 XC10G Card Specifications

The XC10G card has the following specifications:

- Environmental
 - Operating temperature:
 - C-Temp (15454-XC-10G): 32 to 131 degrees Fahrenheit (0 to +55 degrees Celsius)
 - Operating humidity: 5 to 85%, noncondensing
 - Power consumption: 48 W, 1.64 A, 268.4 BTU/hr
- Dimensions
 - Height: 12.650 in. (321.3 mm)
 - Width: 0.716 in. (18.2 mm)
 - Depth: 9.000 in. (228.6 mm)
 - Card weight: 1.5 lb (0.6 kg)
- Compliance
 - For compliance information, refer to the *Cisco Optical Transport Products Safety and Compliance Information*.

2.6 AIC Card

The optional Alarm Interface Controller (AIC) card provides customer-defined alarm input/output (I/O) and supports local and express orderwire. [Figure 2-9](#) shows the AIC faceplate and a block diagram of the card.

Figure 2-9 AIC Faceplate and Block Diagram

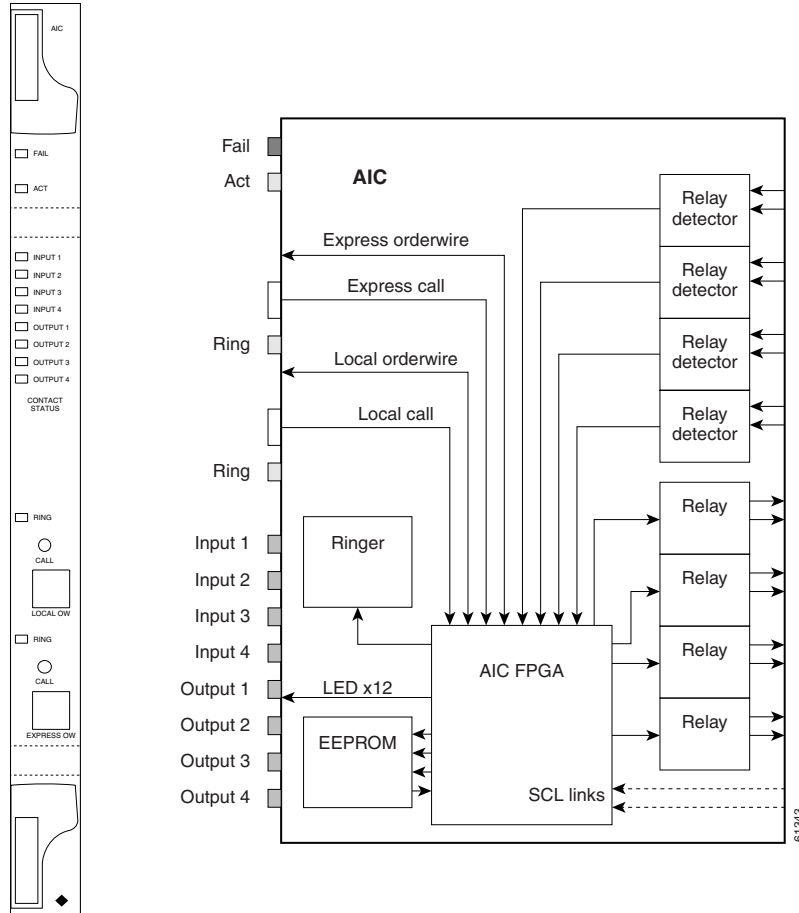

2.6.1 External Alarms and Controls

The AIC card provides provisionable input/output alarm contact closures for up to four external alarms and four external controls. The physical connections are made using the backplane wire-wrap pins. The alarms are defined using CTC and TL1. For instructions, refer to the *Cisco ONS 15454 Procedure Guide*.

Each alarm contact has a corresponding LED on the front panel of the AIC that indicates the status of the alarm. External alarms (input contacts) are typically used for external sensors such as open doors, temperature sensors, flood sensors, and other environmental conditions. External controls (output contacts) are typically used to drive visual or audible devices such as bells and lights, but they can control other devices such as generators, heaters, and fans.

You can program each of the four input alarm contacts separately. Choices include:

- Alarm on Closure or Alarm on Open
- Alarm severity of any level (Critical, Major, Minor, Not Alarmed, Not Reported)
- Service Affecting or Non-Service Affecting alarm-service level

- 63-character alarm description for CTC display in the alarm log. You cannot assign the fan-tray abbreviation for the alarm; the abbreviation reflects the generic name of the input contacts. The alarm condition remains raised until the external input stops driving the contact or you provision the alarm input.

The output contacts can be provisioned to close on a trigger or to close manually. The trigger can be a local alarm severity threshold, a remote alarm severity, or a virtual wire:

- Local NE alarm severity: A hierarchy of non-reported, non-alarmed, minor, major or critical alarm severities that you set to cause output closure. For example, if the trigger is set to minor, a minor alarm or above is the trigger.
- Remote NE alarm severity: Same as the Local NE alarm severity but applies to remote alarms only.
- Virtual wire entities: You can provision any environmental alarm input to raise a signal on any virtual wire on external outputs 1 through 4 when the alarm input is an event. You can provision a signal on any virtual wire as a trigger for an external control output.

You can also program the output alarm contacts (external controls) separately. In addition to provisionable triggers, you can manually force each external output contact to open or close. Manual operation takes precedence over any provisioned triggers that might be present.

2.6.2 Orderwire

Orderwire allows a craftsman to plug a phoneset into an ONS 15454 and communicate with craftspeople working at other ONS 15454s or other facility equipment. The orderwire is a pulse code modulation (PCM) encoded voice channel that uses E1 or E2 bytes in section/line overhead.

The AIC allows simultaneous use of both local (section overhead signal) and express (line overhead channel) orderwire channels on a SONET ring or particular optics facility. Local orderwire also allows communication at regeneration sites when the regenerator is not a Cisco device.

You can provision orderwire functions with CTC similar to the current provisioning model for DCC/GCC channels. In CTC you provision the orderwire communications network during ring turn-up so that all NEs on the ring can reach one another. Orderwire terminations (that is, the optics facilities that receive and process the orderwire channels) are provisionable. Both express and local orderwire can be configured as on or off on a particular SONET facility. The ONS 15454 supports up to four orderwire channel terminations per shelf, which allow linear, single ring, dual ring, and small hub-and-spoke configurations. Orderwire is not protected in ring topologies such as BLSR and path protection.



Caution

Do not configure orderwire loops. Orderwire loops cause feedback that disables the orderwire channel.

The ONS 15454 implementation of both local and express orderwire is broadcast in nature. The line acts as a party line. There is no signaling for private point-to-point connections. Anyone who picks up the orderwire channel can communicate with all other participants on the connected orderwire subnetwork. The local orderwire party line is separate from the express orderwire party line. Up to four OC-N facilities for each local and express orderwire are provisionable as orderwire paths.

The AIC supports a “call” button on the module front panel which, when pressed, causes all ONS 15454 AICs on the orderwire subnetwork to “ring.” The ringer/buzzer resides on the AIC. There is also a “ring” LED that mimics the AIC ringer. It flashes when any “call” button is pressed on the orderwire subnetwork. The “call” button and ringer LED allow a remote craftsman to get the attention of craftspeople across the network.

Table 2-17 shows the pins on the orderwire ports that correspond to the tip and ring orderwire assignments.

Table 2-17 Orderwire Pin Assignments

RJ-11 Pin Number	Description
1	Four-wire receive ring
2	Four-wire transmit tip
3	Two-wire ring
4	Two-wire tip
5	Four-wire transmit ring
6	Four-wire receive tip

When provisioning the orderwire subnetwork, make sure that an orderwire loop does not exist. Loops cause oscillation and an unusable orderwire channel. [Figure 2-10](#) shows the standard RJ-11 orderwire pins.

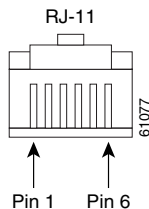
Figure 2-10 RJ-11 Connector

2.6.3 AIC Card Specifications

The AIC card has the following specifications:

- Environmental
 - Operating temperature:
 - C-Temp (15454-AIC): 32 to 131 degrees Fahrenheit (0 to +55 degrees Celsius)
 - I-Temp (15454-AIC-T): –40 to 149 degrees Fahrenheit (–40 to +65 degrees Celsius)
 - Operating humidity: 5 to 95%, noncondensing
 - Power consumption: 6.01 W, 0.12 A, 20.52 BTU/hr
- Dimensions
 - Height: 12.650 in. (321.3 mm)
 - Width: 0.716 in. (18.2 mm)
 - Depth: 9.000 in. (228.6 mm)
 - Card weight: 1.6 lb (0.7 kg)
- Compliance
 - For compliance information, refer to the *Cisco Optical Transport Products Safety and Compliance Information*.

2.7 AIC-I Card

The optional Alarm Interface Controller-International (AIC-I) card provides customer-defined (environmental) alarms and controls and supports local and express orderwire. It provides 12 customer-defined input and 4 customer-defined input/output contacts. The physical connections are via the backplane wire-wrap pin terminals. If you use the additional alarm expansion panel (AEP), the AIC-I card can support up to 32 inputs and 16 outputs, which are connected on the AEP connectors. A power monitoring function monitors the supply voltage (–48 VDC). [Figure 2-11](#) shows the AIC-I faceplate and a block diagram of the card.

Note

After you have upgraded a shelf to the AIC-I card and set new attributes, you cannot downgrade the shelf back to the AIC card.

Figure 2-11 AIC-I Faceplate and Block Diagram

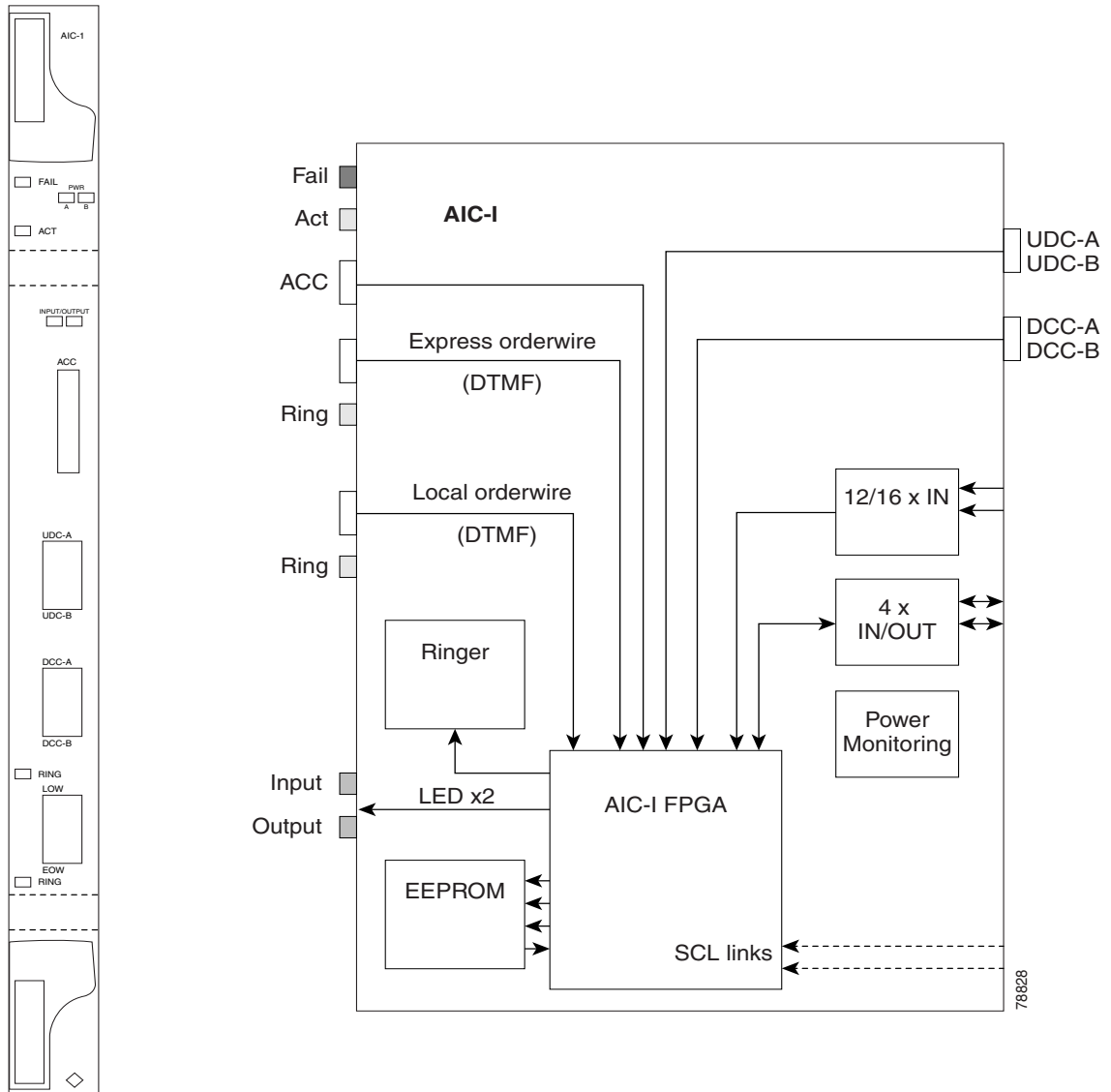

2.7.1 AIC-I Card-Level Indicators

Table 2-18 describes the eight card-level LEDs on the AIC-I card faceplate.

Table 2-18 AIC-I Card-Level Indicators

Card-Level LEDs	Description
Red FAIL LED	Indicates that the card's processor is not ready. The FAIL LED is on during Reset and flashes during the boot process. Replace the card if the red FAIL LED persists.
Green ACT LED	Indicates the AIC-I card is provisioned for operation.
Green/red PWR A LED	The PWR A LED is green when a supply voltage within specified range has been sensed on supply input A. It is red when the input voltage on supply input A is out of range.
Green/red PWR B LED	The PWR B LED is green when a supply voltage within specified range has been sensed on supply input B. It is red when the input voltage on supply input B is out of range.
Yellow INPUT LED	The INPUT LED is yellow when there is an alarm condition on at least one of the alarm inputs.
Yellow OUTPUT LED	The OUTPUT LED is yellow when there is an alarm condition on at least one of the alarm outputs.
Green RING LED	The RING LED on the local orderwire (LOW) side is flashing green when a call is received on the LOW.
Green RING LED	The RING LED on the express orderwire (EOW) side is flashing green when a call is received on the EOW.

2.7.2 External Alarms and Controls

The AIC-I card provides input/output alarm contact closures. You can define up to 12 external alarm inputs and 4 external alarm inputs/outputs (user configurable). The physical connections are made using the backplane wire-wrap pins. See the “[1.9 Alarm Expansion Panel](#)” section on page 1-30 for information about increasing the number of input/output contacts.

LEDs on the front panel of the AIC-I indicate the status of the alarm lines, one LED representing all of the inputs and one LED representing all of the outputs. External alarms (input contacts) are typically used for external sensors such as open doors, temperature sensors, flood sensors, and other environmental conditions. External controls (output contacts) are typically used to drive visual or audible devices such as bells and lights, but they can control other devices such as generators, heaters, and fans.

You can program each of the twelve input alarm contacts separately. You can program each of the sixteen input alarm contacts separately. Choices include:

- Alarm on Closure or Alarm on Open
- Alarm severity of any level (Critical, Major, Minor, Not Alarmed, Not Reported)
- Service Affecting or Non-Service Affecting alarm-service level

- 63-character alarm description for CTC display in the alarm log. You cannot assign the fan-tray abbreviation for the alarm; the abbreviation reflects the generic name of the input contacts. The alarm condition remains raised until the external input stops driving the contact or you unprovision the alarm input.

You cannot assign the fan-tray abbreviation for the alarm; the abbreviation reflects the generic name of the input contacts. The alarm condition remains raised until the external input stops driving the contact or you provision the alarm input.

The output contacts can be provisioned to close on a trigger or to close manually. The trigger can be a local alarm severity threshold, a remote alarm severity, or a virtual wire:

- Local NE alarm severity: A hierarchy of non-reported, non-alarmed, minor, major or critical alarm severities that you set to cause output closure. For example, if the trigger is set to minor, a minor alarm or above is the trigger.
- Remote NE alarm severity: Same as the Local NE alarm severity but applies to remote alarms only.
- Virtual wire entities: You can provision any environmental alarm input to raise a signal on any virtual wire on external outputs 1 through 4 when the alarm input is an event. You can provision a signal on any virtual wire as a trigger for an external control output.

You can also program the output alarm contacts (external controls) separately. In addition to provisionable triggers, you can manually force each external output contact to open or close. Manual operation takes precedence over any provisioned triggers that might be present.

**Note**

The number of inputs and outputs can be increased using the AEP. The AEP is connected to the shelf backplane and requires an external wire-wrap panel.

2.7.3 Orderwire

Orderwire allows a craftsperson to plug a phoneset into an ONS 15454 and communicate with craftspeople working at other ONS 15454s or other facility equipment. The orderwire is a pulse code modulation (PCM) encoded voice channel that uses E1 or E2 bytes in section/line overhead.

The AIC-I allows simultaneous use of both local (section overhead signal) and express (line overhead channel) orderwire channels on a SONET ring or particular optics facility. Express orderwire also allows communication via regeneration sites when the regenerator is not a Cisco device.

You can provision orderwire functions with CTC similar to the current provisioning model for DCC/GCC channels. In CTC you provision the orderwire communications network during ring turn-up so that all NEs on the ring can reach one another. Orderwire terminations (that is, the optics facilities that receive and process the orderwire channels) are provisionable. Both express and local orderwire can be configured as on or off on a particular SONET facility. The ONS 15454 supports up to four orderwire channel terminations per shelf. This allows linear, single ring, dual ring, and small hub-and-spoke configurations. Keep in mind that orderwire is not protected in ring topologies such as BLSR and path protection.

**Caution**

Do not configure orderwire loops. Orderwire loops cause feedback that disables the orderwire channel.

The ONS 15454 implementation of both local and express orderwire is broadcast in nature. The line acts as a party line. Anyone who picks up the orderwire channel can communicate with all other participants on the connected orderwire subnetwork. The local orderwire party line is separate from the express orderwire party line. Up to four OC-N facilities for each local and express orderwire are provisionable as orderwire paths.

**Note**

The OC3 IR 4/STM1 SH 1310 card does not support the express orderwire channel.

The AIC-I supports selective dual tone multifrequency (DTMF) dialing for telephony connectivity, which causes one AIC-I card or all ONS 15454 AIC-I cards on the orderwire subnetwork to “ring.” The ringer/buzzer resides on the AIC-I. There is also a “ring” LED that mimics the AIC-I ringer. It flashes when a call is received on the orderwire subnetwork. A party line call is initiated by pressing *0000 on the DTMF pad. Individual dialing is initiated by pressing * and the individual four-digit number on the DTMF pad.

Table 2-19 shows the pins on the orderwire connector that correspond to the tip and ring orderwire assignments. , shown in .

Table 2-19 Orderwire Pin Assignments

RJ-11 Pin Number	Description
1	Four-wire receive ring
2	Four-wire transmit tip
3	Two-wire ring
4	Two-wire tip
5	Four-wire transmit ring
6	Four-wire receive tip

When provisioning the orderwire subnetwork, make sure that an orderwire loop does not exist. Loops cause oscillation and an unusable orderwire channel.

Figure 2-12 shows the standard RJ-11 connectors used for orderwire ports.

Figure 2-12 RJ-11 Connector

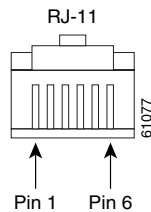

2.7.4 Power Monitoring

The AIC-I card provides a power monitoring circuit that monitors the supply voltage of –48 VDC for presence, undervoltage, or overvoltage.

2.7.5 User Data Channel

The user data channel (UDC) features a dedicated data channel of 64 kbps (F1 byte) between two nodes in an ONS 15454 network. Each AIC-I card provides two user data channels, UDC-A and UDC-B, through separate RJ-11 connectors on the front of the AIC-I card. Each UDC can be routed to an individual optical interface in the ONS 15454. For instructions, refer to the *Cisco ONS 15454 Procedure Guide*.

The UDC ports are standard RJ-11 receptacles. [Table 2-20](#) lists the UDC pin assignments.

Table 2-20 UDC Pin Assignments

RJ-11 Pin Number	Description
1	For future use
2	TXN
3	RXN
4	RXP
5	TXP
6	For future use

2.7.6 Data Communications Channel

The DCC features a dedicated data channel of 576 kbps (D4 to D12 bytes) between two nodes in an ONS 15454 network. Each AIC-I card provides two data communications channels, DCC-A and DCC-B, through separate RJ-45 connectors on the front of the AIC-I card. Each DCC can be routed to an individual optical interface in the ONS 15454. For instructions, refer to the *Cisco ONS 15454 Procedure Guide*.

The DCC ports are standard RJ-45 receptacles. [Table 2-21](#) lists the DCC pin assignments.

Table 2-21 DCC Pin Assignments

RJ-45 Pin Number	Description
1	TCLKP
2	TCLKN
3	TXP
4	TXN
5	RCLKP
6	RCLKN
7	RXP
8	RXN

2.7.7 AIC-I Card Specifications

The AIC-I card has the following specifications:

- Alarm inputs

- Number of inputs: 12 without AEP, 32 with AEP
- Opto coupler isolated
- Label customer provisionable
- Severity customer provisionable
- Common 32 V output for all alarm inputs
- Each input limited to 2 mA
- Termination: Wire-wrap on backplane without AEP, on AEP connectors with AEP
- Alarm outputs
 - Number of outputs: 4 (user configurable as inputs) without AEP, 16 with AEP
 - Switched by opto MOS (metal oxide semiconductor)
 - Triggered by definable alarm condition
 - Maximum allowed open circuit voltage: 60 VDC
 - Maximum allowed closed circuit current: 100 mA
 - Termination: Wire-wrap on backplane without AEP, on AEP connectors with AEP
- EOW/LOW
 - ITU-T G.711, ITU-T G.712, Telcordia GR-253-CORE
 - A-law, mu-law



Note Due to the nature of mixed coding, in a mixed-mode configuration A-law/mu-law the orderwire is not ITU-T G.712 compliant.

- Orderwire party line
- DTMF signaling
- UDC
 - Bit rate: 64 kbps, codirectional
 - ITU-T G.703
 - Input/output impedance: 120 ohm
 - Termination: RJ-11 connectors
- DCC
 - Bit rate: 576 kbps
 - EIA/TIA-485/V11
 - Input/output impedance: 120 ohm
 - Termination: RJ-45 connectors
- ACC connection for additional alarm interfaces
 - Connection to AEP

- Power monitoring alarming states:
 - Power failure (0 to –38 VDC)
 - Undervoltage (–38 to –40.5 VDC)
 - Overvoltage (beyond –56.7 VDC)
- Environmental
 - Operating temperature: –40 to 149 degrees Fahrenheit (–40 to +65 degrees Celsius)
 - Operating humidity: 5 to 95%, noncondensing
 - Power consumption (including AEP, if used): 8.00 W, 0.17 A, 27.3 BTU/hr
- Dimensions
 - Height: 12.650 in. (321.3 mm)
 - Width: 0.716 in. (18.2 mm)
 - Depth: 9.000 in. (228.6 mm)
 - Card weight: 1.8 lb (0.82 kg)
- Compliance
 - For compliance information, refer to the *Cisco Optical Transport Products Safety and Compliance Information*.