



# Configure Segment Routing Path Computation Element

The Segment Routing Path Computation Element (SR-PCE) provides stateful PCE functionality by extending the existing IOS-XR PCEP functionality with additional capabilities. SR-PCE is supported on the MPLS data plane and IPv4 control plane.

**Table 1: Feature History Table**

Feature Name	Release Information	Feature Description
SR-PCE: Single PCE scale enhancement	Release 7.5.1	With this feature, support for a single PCE is enhanced to 50000 nodes, 100000 LSPs, 500000 links, and 2000 PCEP sessions.

- [About SR-PCE, on page 1](#)
- [Usage Guidelines and Limitations, on page 3](#)
- [Configure SR-PCE, on page 3](#)
- [PCE-Initiated SR Policies, on page 7](#)
- [SR-PCE Flexible Algorithm Multi-Domain Path Computation, on page 9](#)
- [Exclude Network Resources during Path Computation over SR-TE Policies, on page 14](#)
- [Configure the Shortest Path for Disjoint Candidate Paths, on page 19](#)
- [Enable Strict Disjointness for SR-TE policies in the PCE, on page 22](#)
- [ACL Support for PCEP Connection, on page 24](#)
- [Anycast SID-Aware Path Computation, on page 24](#)
- [SR-PCE IPv4 Unnumbered Interface Support, on page 29](#)
- [Inter-Domain Path Computation Using Redistributed SID, on page 31](#)
- [PCE Support for MPLS-TE LSPs, on page 34](#)
- [Configuring the North-Bound API on SR-PCE, on page 37](#)

## About SR-PCE

The path computation element protocol (PCEP) describes a set of procedures by which a path computation client (PCC) can report and delegate control of head-end label switched paths (LSPs) sourced from the PCC to a PCE peer. The PCE can request the PCC to update and modify parameters of LSPs it controls. The stateful

model also enables a PCC to allow the PCE to initiate computations allowing the PCE to perform network-wide orchestration.

SR-PCE learns topology information by way of IGP (OSPF or IS-IS) or through BGP Link-State (BGP-LS).

SR-PCE is capable of computing paths using the following methods:

- TE metric—SR-PCE uses the TE metric in its path calculations to optimize cumulative TE metric.
- IGP metric—SR-PCE uses the IGP metric in its path calculations to optimize reachability.
- LSP Disjointness—SR-PCE uses the path computation algorithms to compute a pair of disjoint LSPs. The disjoint paths can originate from the same head-end or different head-ends. Disjoint level refers to the type of resources that should not be shared by the two computed paths. SR-PCE supports the following disjoint path computations:
  - Link – Specifies that links are not shared on the computed paths.
  - Node – Specifies that nodes are not shared on the computed paths.
  - SRLG – Specifies that links with the same SRLG value are not shared on the computed paths.
  - SRLG-node – Specifies that SRLG and nodes are not shared on the computed paths.

When the first request is received with a given disjoint-group ID, the first LSP is computed, encoding the shortest path from the first source to the first destination. When the second LSP request is received with the same disjoint-group ID, information received in both requests is used to compute two disjoint paths: one path from the first source to the first destination, and another path from the second source to the second destination. Both paths are computed at the same time.

### TCP Authentication Option

TCP Message Digest 5 (MD5) authentication has been used for authenticating PCEP (TCP) sessions by using a clear text or encrypted password. This feature introduces support for TCP Authentication Option (TCP-AO), which replaces the TCP MD5 option.

TCP-AO uses Message Authentication Codes (MACs), which provides the following:

- Protection against replays for long-lived TCP connections
- More details on the security association with TCP connections than TCP MD5
- A larger set of MACs with minimal system and operational changes

TCP-AO is compatible with Master Key Tuple (MKT) configuration. TCP-AO also protects connections when using the same MKT across repeated instances of a connection. TCP-AO protects the connections by using traffic key that are derived from the MKT, and then coordinates changes between the endpoints.



---

**Note** TCP-AO and TCP MD5 are never permitted to be used simultaneously. TCP-AO supports IPv6, and is fully compatible with the proposed requirements for the replacement of TCP MD5.

---

# Usage Guidelines and Limitations

To ensure PCEP compatibility, we recommend that the Cisco IOS XR version on the SR-PCE be the same or later than the Cisco IOS XR version on the PCC or head-end.

## Configure SR-PCE

This task explains how to configure SR-PCE.

### SUMMARY STEPS

1. **configure**
2. **pce**
3. **address ipv4** *address*
4. **state-sync ipv4** *address*
5. **tcp-buffer size** *size*
6. **password** {**clear** | **encrypted**} *password*
7. **tcp-ao** *key-chain* [**include-tcp-options**] [**accept-ao-mismatch-connection**]
8. **segment-routing** {**strict-sid-only** | **te-latency**}
9. **timers**
10. **keepalive** *time*
11. **minimum-peer-keepalive** *time*
12. **reoptimization** *time*
13. **exit**

### DETAILED STEPS

	Command or Action	Purpose
Step 1	<b>configure</b> <b>Example:</b> RP/0/RP0/CPU0:router# <code>configure</code>	Enters global configuration mode.
Step 2	<b>pce</b> <b>Example:</b> RP/0/RP0/CPU0:router(config)# <code>pce</code>	Enables PCE and enters PCE configuration mode.
Step 3	<b>address ipv4</b> <i>address</i> <b>Example:</b> RP/0/RP0/CPU0:router(config-pce)# <code>address ipv4 192.168.0.1</code>	Configures a PCE IPv4 address.

	Command or Action	Purpose
<b>Step 4</b>	<p><b>state-sync ipv4</b> <i>address</i></p> <p><b>Example:</b></p> <pre>RP/0/RP0/CPU0:router(config-pce)# state-sync ipv4 192.168.0.3</pre>	Configures the remote peer for state synchronization.
<b>Step 5</b>	<p><b>tcp-buffer size</b> <i>size</i></p> <p><b>Example:</b></p> <pre>RP/0/RP0/CPU0:router(config-pce)# tcp-buffer size 1024000</pre>	Configures the transmit and receive TCP buffer size for each PCEP session, in bytes. The default buffer size is 256000. The valid range is from 204800 to 1024000.
<b>Step 6</b>	<p><b>password</b> {<b>clear</b>   <b>encrypted</b>} <i>password</i></p> <p><b>Example:</b></p> <pre>RP/0/RP0/CPU0:router(config-pce)# password encrypted pwd1</pre>	<p>Enables TCP MD5 authentication for all PCEP peers. Any TCP segment coming from the PCC that does not contain a MAC matching the configured password will be rejected. Specify if the password is encrypted or clear text.</p> <p><b>Note</b> TCP-AO and TCP MD5 are never permitted to be used simultaneously.</p>
<b>Step 7</b>	<p><b>tcp-ao</b> <i>key-chain</i> [<b>include-tcp-options</b>] [<b>accept-ao-mismatch-connection</b>]</p> <p><b>Example:</b></p> <pre>RP/0/RP0/CPU0:router(config-pce)# tcp-ao pce_tcp_ao include-tcp-options</pre>	<p>Enables TCP Authentication Option (TCP-AO) authentication for all PCEP peers. Any TCP segment coming from the PCC that does not contain a MAC matching the configured key chain will be rejected.</p> <ul style="list-style-type: none"> <li>• <b>include-tcp-options</b>—Includes other TCP options in the header for MAC calculation.</li> <li>• <b>accept-ao-mismatch-connection</b>—Accepts connection even if there is a mismatch of AO options between peers.</li> </ul> <p><b>Note</b> TCP-AO and TCP MD5 are never permitted to be used simultaneously.</p>
<b>Step 8</b>	<p><b>segment-routing</b> {<b>strict-sid-only</b>   <b>te-latency</b>}</p> <p><b>Example:</b></p> <pre>RP/0/RP0/CPU0:router(config-pce)# segment-routing strict-sid-only</pre>	<p>Configures the segment routing algorithm to use strict SID or TE latency.</p> <p><b>Note</b> This setting is global and applies to all LSPs that request a path from this controller.</p>
<b>Step 9</b>	<p><b>timers</b></p> <p><b>Example:</b></p> <pre>RP/0/RP0/CPU0:router(config-pce)# timers</pre>	Enters timer configuration mode.

	Command or Action	Purpose
Step 10	<b>keepalive</b> <i>time</i> <b>Example:</b> RP/0/RP0/CPU0:router(config-pce-timers)# <b>keepalive</b> <b>60</b>	Configures the timer value for locally generated keep-alive messages. The default time is 30 seconds.
Step 11	<b>minimum-peer-keepalive</b> <i>time</i> <b>Example:</b> RP/0/RP0/CPU0:router(config-pce-timers)# <b>minimum-peer-keepalive 30</b>	Configures the minimum acceptable keep-alive timer that the remote peer may propose in the PCEP OPEN message during session establishment. The default time is 20 seconds.
Step 12	<b>reoptimization</b> <i>time</i> <b>Example:</b> RP/0/RP0/CPU0:router(config-pce-timers)# <b>reoptimization 600</b>	Configures the re-optimization timer. The default timer is 1800 seconds.
Step 13	<b>exit</b> <b>Example:</b> RP/0/RP0/CPU0:router(config-pce-timers)# <b>exit</b>	Exits timer configuration mode and returns to PCE configuration mode.

## Configure the Disjoint Policy (Optional)

This task explains how to configure the SR-PCE to compute disjointness for a pair of LSPs signaled by PCCs that do not include the PCEP association group-ID object in their PCEP request. This can be beneficial for deployments where PCCs do not support this PCEP object or when the network operator prefers to manage the LSP disjoint configuration centrally.

### SUMMARY STEPS

1. **disjoint-path**
2. **group-id** *value* **type** {link | node | srlg | srlg-node} [**sub-id** *value*]
3. **strict**
4. **lsp** {1 | 2} **pcc** *ipv4 address* **lsp-name** *lsp\_name* [**shortest-path**]

### DETAILED STEPS

	Command or Action	Purpose
Step 1	<b>disjoint-path</b> <b>Example:</b>	Enters disjoint configuration mode.

	Command or Action	Purpose
	RP/0/RP0/CPU0:router(config-pce)# <b>disjoint-path</b>	
<b>Step 2</b>	<p><b>group-id</b> <i>value</i> <b>type</b> {<b>link</b>   <b>node</b>   <b>srlg</b>   <b>srlg-node</b>} [<b>sub-id</b> <i>value</i>]</p> <p><b>Example:</b></p> <pre>RP/0/RP0/CPU0:router(config-pce-disjoint)# group-id 1 type node sub-id 1</pre>	<p>Configures the disjoint group ID and defines the preferred level of disjointness (the type of resources that should not be shared by the two paths):</p> <ul style="list-style-type: none"> <li>• <b>link</b>—Specifies that links are not shared on the computed paths.</li> <li>• <b>node</b>—Specifies that nodes are not shared on the computed paths.</li> <li>• <b>srlg</b>—Specifies that links with the same SRLG value are not shared on the computed paths.</li> <li>• <b>srlg-node</b>—Specifies that SRLG and nodes are not shared on the computed paths.</li> </ul> <p>If a pair of paths that meet the requested disjointness level cannot be found, then the paths will automatically fallback to a lower level:</p> <ul style="list-style-type: none"> <li>• If the requested disjointness level is SRLG or node, then link-disjoint paths will be computed.</li> <li>• If the requested disjointness level was link, or if the first fallback from SRLG or node disjointness failed, then the lists of segments encoding two shortest paths, without any disjointness constraint, will be computed.</li> </ul>
<b>Step 3</b>	<p><b>strict</b></p> <p><b>Example:</b></p> <pre>RP/0/RP0/CPU0:router(config-pce-disjoint)# strict</pre>	<p>(Optional) Prevents the automatic fallback behavior of the preferred level of disjointness. If a pair of paths that meet the requested disjointness level cannot be found, the disjoint calculation terminates and no new path is provided. The existing path is not modified.</p>
<b>Step 4</b>	<p><b>lsp</b> {<b>1</b>   <b>2</b>} <b>pcc ipv4</b> <i>address</i> <b>lsp-name</b> <i>lsp_name</i> [<b>shortest-path</b>]</p> <p><b>Example:</b></p> <pre>RP/0/RP0/CPU0:router(config-pce-disjoint)# lsp 1 pcc ipv4 192.168.0.1 lsp-name rtrA_t1 shortest-path RP/0/RP0/CPU0:router(config-pce-disjoint)# lsp 2 pcc ipv4 192.168.0.5 lsp-name rtrE_t2</pre>	<p>Adds LSPs to the disjoint group.</p> <p>The <b>shortest-path</b> keyword forces one of the disjoint paths to follow the shortest path from the source to the destination. This option can only be applied to the the first LSP specified.</p>

## Global Maximum-delay Constraint

This feature allows a PCE to compare the cumulative latency of a computed path against a global maximum-delay constraint value. If the latency of the computed path exceeds this global constraint, the path

is not considered valid. This ensures that all latency-based paths computed by the PCE and signaled to the PCCs in the network do not exceed this maximum-delay constraint.

```
pce
  constraints
    bounds
      cumulative
        type
          latency <1-4294967295> Bound metric value in microseconds
```

### Configuration

To configure a PCE for specifying maximum cumulative latency metric, you must complete the following configurations:

```
RP/0/RSP0/CPU0:ios(config)# pce
RP/0/RSP0/CPU0:ios(config-pce)# constraints
RP/0/RSP0/CPU0:ios(config-pce-constr)# bounds
RP/0/RSP0/CPU0:ios(config-pce-constr-bounds)# cumulative
RP/0/RSP0/CPU0:ios(config-pce-constr-bounds-type)# type latency 1000000
RP/0/RSP0/CPU0:ios(config-pce-constr-bounds-type)#
```

### Verification

Verify using the **show** command:

```
RP/0/RSP0/CPU0:ios(config-pce-constr-bounds-type)# show
Wed Oct 12 22:18:22.962 UTC
pce
  constraints
    bounds
      cumulative
        type latency 1000000
    !
  !
!
```

## PCE-Initiated SR Policies

Use cases based on centralized optimization, such as congestion mitigation solutions, rely on the ability of the PCE to signal and instantiate SR-TE policies in the network. We refer to this as PCE-initiated SR-TE policies.

PCE-initiated SR-TE policies can be triggered via Crossworks Network Controller (recommended approach) or via CLI at the PCE.

For more information on configuring SR-TE policies, see the [SR-TE Policy Overview](#).

The PCE deploys the SR-TE policy using PCC-PCE communication protocol (PCEP).

1. PCE sends a PCInitiate message to the PCC.
2. If the PCInitiate message is valid, the PCC sends a PCRpt message; otherwise, it sends PCErr message.
3. If the PCInitiate message is accepted, the PCE updates the SR-TE policy by sending PCUpd message.

You can achieve high-availability by configuring multiple PCEs with SR-TE policies. If the head-end (PCC) loses connectivity with one PCE, another PCE can assume control of the SR-TE policy.

### Configuration Example: PCE-Initiated SR Policy with Explicit SID List

To configure a PCE-initiated SR-TE policy, you must complete the following configurations:

1. Enter PCE configuration mode.
2. Create the segment list.



---

**Note** When configuring an explicit path using IP addresses of intermediate links, the SR-TE process prefers the protected Adj-SID of the link, if one is available.

---

3. Create the policy.

```

/* Enter PCE configuration mode and create the SR-TE segment lists */
Router# configure
Router(config)# pce

/* Create the SR-TE segment lists */
Router(config-pce)# segment-routing
Router(config-pce-sr)# traffic-eng
Router(config-pce-sr-te)# segment-list name addr2a
Router(config-pce-sr-te-sl)# index 10 address ipv4 10.1.1.2
Router(config-pce-sr-te-sl)# index 20 address ipv4 10.2.3.2
Router(config-pce-sr-te-sl)# index 30 address ipv4 10.1.1.4
Router(config-pce-sr-te-sl)# exit

/* Create the SR-TE policy */
Router(config-pce-sr-te)# peer ipv4 10.1.1.1
Router(config-pce-sr-te)# policy P1
Router(config-pce-sr-te-policy)# color 2 end-point ipv4 2.2.2.2
Router(config-pce-sr-te-policy)# candidate-paths
Router(config-pce-sr-te-policy-path)# preference 50
Router(config-pce-sr-te-policy-path-preference)# explicit segment-list addr2a
Router(config-pce-sr-te-pp-info)# commit
Router(config-pce-sr-te-pp-info)# end
Router(config)#

```

### Running Config

```

pce
 segment-routing
  traffic-eng
  segment-list name addr2a
    index 10 address ipv4 10.1.1.2
    index 20 address ipv4 10.2.3.2
    index 30 address ipv4 10.1.1.4
  !
  peer ipv4 10.1.1.1
  policy P1
    color 2 end-point ipv4 2.2.2.2
    candidate-paths
    preference 50

```



```

explicit segment-list addr2a
!
!

```

## SR-PCE Flexible Algorithm Multi-Domain Path Computation

Table 2: Feature History Table

Feature Name	Release Information	Feature Description
SR-PCE: Flex Algo Aware Policy Computation + Live-Live Disjointness Enhancements	Release 7.3.1	This feature is now supported on routers that have the Cisco NC57 line cards installed and operate in the native and compatible modes. To enable the native mode, use the <b>hw-module profile npu native-mode-enable</b> command in the configuration mode. Ensure that you reload the router after configuring the native mode.

Flexible Algorithm provides a traffic engineered path automatically computed by the IGP to any destination reachable by the IGP. With the SR-PCE Flexible Algorithm Multi-Domain Path Computation feature, SR-PCE can use Flexible Algorithms to compute multi-domain paths. See the [Enabling Segment Routing Flexible Algorithm](#) chapter for information about Segment Routing Flexible Algorithm.

The SR-PCE Flexible Algorithm Multi-Domain Path Computation feature incorporates the following functionality:

- BGP-LS has been augmented to allow selected nodes to advertise the Flexible Algorithm definition (FAD) to the SR-PCE
- PCEP has been augmented (vendor-specific object) to allow a PCC to indicate SR policy constraint based on the Flexible Algorithm instance number
- SR-PCE algorithms have been augmented to compute paths based on a Flexible Algorithm constraint

The SR-PCE Flexible Algorithm multi-domain path computation requires the following:

- The same Flexible Algorithm instance ID is used across domains.
- The metric for those Flexible Algorithm instances must be the same across domains.
- The affinity constraints for those Flexible Algorithm instances may be different across domains.
- Multiple Flexible Algorithms can exist in a domain.

For example, considering a multi-domain topology (Domain 1 and Domain 2), the following scenarios meet the requirements listed above:

Scenario	Domain 1	Domain 2
Scenario 1	Flexible Algorithm 128, metric delay	Flexible Algorithm 128, metric delay

Scenario	Domain 1	Domain 2
Scenario 2	Flexible Algorithm 128, metric delay	Flexible Algorithm 128, metric delay, exclude affinity blue
Scenario 3	Flexible Algorithm 128, metric delay, exclude affinity yellow	Flexible Algorithm 128, metric delay, exclude affinity blue
Scenario 4	Flexible Algorithm 128, metric delay Flexible Algorithm 129, metric IGP	Flexible Algorithm 128, metric delay Flexible Algorithm 129, metric IGP



**Note** The use of a Flexible Algorithm constraint in a multi-domain SR topology does not preclude the use of an SR policy that are optimized for a particular metric type. For example, a policy can request a PCE for a Multi Domain policy based on metric delay. SR-PCE computes the path and encodes it with regular prefix SIDs and Adj-SIDs as required. Alternatively, a policy can request to have a constraint for a Flexible Algorithm instance X, which is defined in multiple domains and it minimizes based on metric delay. In this case, the SR-PCE computes the multi-domain path and encodes it using only Flexible Algorithm prefix SIDs. This case benefits from the optimized label stack size that Flexible Algorithm provides (1 label per domain).

## Example: SR-PCE Flexible Algorithm Multi-Domain Path Computation Use Case

The following use case depicts a multi-domain topology with two IS-IS processes, each with a Flexible Algorithm instance of 128 that minimizes metric delay. A multi-domain SR policy programmed at Node 1 leverages a Flexible Algorithm 128 path computed by the SR-PCE toward Node 8.

Figure 1: Multi-Domain Topology

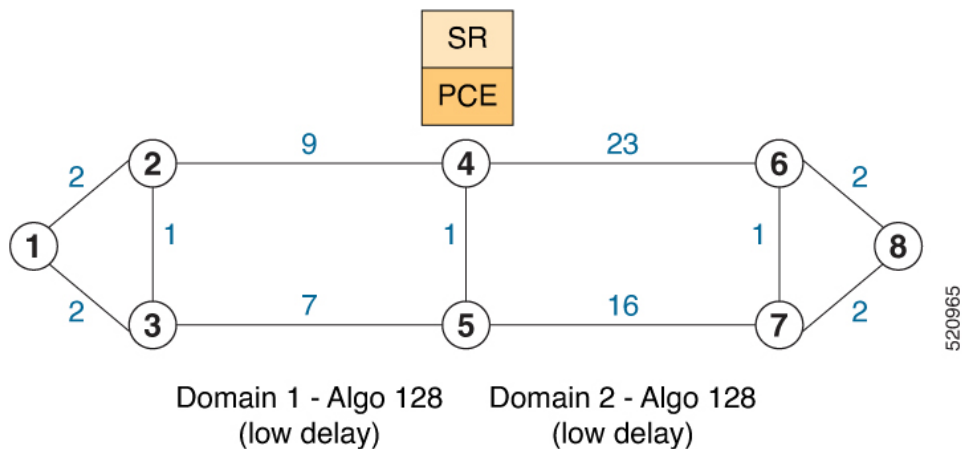

### Configuration on Node 8

#### IS-IS and Flexible Algorithm Configuration

```
router isis 2
 is-type level-2-only
```

```

net 49.0002.0000.0000.0008.00
distribute link-state
flex-algo 128
  metric-type delay
  advertise-definition

address-family ipv4 unicast
  metric-style wide
  router-id 10.1.1.8
  segment-routing mpls
!
interface Loopback0
  passive
  address-family ipv4 unicast
  prefix-sid absolute 16008
  prefix-sid algorithm 128 absolute 16808
!

```

### Configuration on Node 4 (ABR/ASBR)

#### IS-IS and Flexible Algorithm Configuration

```

router isis 1
  is-type level-2-only
  net 49.0001.0000.0000.0004.00
  distribute link-state instance-id 100
  flex-algo 128
    metric-type delay
    advertise-definition

address-family ipv4 unicast
  metric-style wide
  router-id 10.1.1.4
  segment-routing mpls
!
interface Loopback0
  passive
  address-family ipv4 unicast
  prefix-sid absolute 16004
  prefix-sid algorithm 128 absolute 16804
!
router isis 2
  is-type level-2-only
  net 49.0002.0000.0000.0004.00
  distribute link-state instance-id 200
  flex-algo 128
    metric-type delay
    advertise-definition

address-family ipv4 unicast
  metric-style wide
  router-id 10.1.1.4
  segment-routing mpls
!
interface Loopback0
  passive
  address-family ipv4 unicast
  prefix-sid absolute 16004
  prefix-sid algorithm 128 absolute 16804
!

```

#### BGP-LS Configuration

```

router bgp 65000
  bgp router-id 10.1.1.4
  address-family link-state link-state
  !
  neighbor-group AS65000-LS-group
  remote-as 65000
  update-source Loopback0
  address-family link-state link-state
  !
  !
  neighbor 10.1.1.10
  use neighbor-group AS65000-LS-group
  description *** To SR-PCE ***
  !
  !
  !

```

## Configuration on Node 1

### IS-IS and Flexible Algorithm Configuration

```

router isis 1
  is-type level-2-only
  net 49.0001.0000.0000.0001.00
  distribute link-state
  flex-algo 128
    metric-type delay
    advertise-definition

  address-family ipv4 unicast
    metric-style wide
    router-id 10.1.1.1
    segment-routing mpls
  !
  interface Loopback0
    passive
    address-family ipv4 unicast
    prefix-sid absolute 16001
    prefix-sid algorithm 128 absolute 16801
  !

```

### SR Policy Configuration

```

segment-routing
  traffic-eng
  policy FOO
    color 100 end-point ipv4 10.1.1.8
    candidate-paths
    preference 100
    dynamic
    pcep
    !
    !
    constraints
    segments
    sid-algorithm 128
    !
    !
    !
    !
    !
    !

```

```
!
```

### PCC Configuration

```
segment-routing
traffic-eng
  pcc
    source-address ipv4 10.1.1.1
    pce address ipv4 10.1.1.10
    precedence 10
    !
    report-all
    !
  !
!
```

### Configuration on PCE

```
pce
address ipv4 10.1.1.10
rest
!
!
router bgp 65000
  bgp router-id 10.1.1.10
  address-family link-state link-state
  !
  neighbor-group AS65000-LS-group
    remote-as 65000
    update-source Loopback0
  address-family link-state link-state
  !
  !
  neighbor 10.1.1.4
    use neighbor-group AS65000-LS-group
    description *** To Node-4 ***
  !
  !
  neighbor 10.1.1.5
    use neighbor-group AS65000-LS-group
    description *** To Node-5 ***
  !
  !
!
```

# Exclude Network Resources during Path Computation over SR-TE Policies

*Table 3: Feature History Table*

Feature Name	Release Information	Feature Description
Exclude Network Resources during Path Computation over SR-TE Policies	Release 24.1.1	

Feature Name	Release Information	Feature Description
		<p>Introduced in this release on: NCS 5500 fixed port routers; NCS 5700 fixed port routers; NCS 5500 modular routers (NCS 5500 line cards; NCS 5700 line cards [Mode: Compatibility; Native]).</p> <p>You can reduce the risk of attacks due to less secure network resources and IP addresses, improve network performance affected by overloaded or congested paths, and ensure higher levels of network stability and availability that could be impacted by resources experiencing issues and requiring maintenance. These improvements are possible because you can now exclude specific network resources using their IP addresses during path computation for traffic over SR-TE policies.</p> <p>Previously, you could not exclude network resources during path computation.</p> <p>The feature introduces these changes:</p> <p><b>CLI:</b></p> <ul style="list-style-type: none"> <li>• The <b>resources</b> option is introduced in the <b>segment-routing traffic-eng policy</b> and <b>segment-routing traffic-eng on-demand color</b> commands.</li> <li>• The <b>resource-list</b> keyword is introduced in the <b>segment-routing traffic-eng</b> command.</li> </ul> <p><b>YANG Data Models:</b></p> <ul style="list-style-type: none"> <li>• <a href="#">Cisco-IOS-XR-infra-xtc-oper.yang</a></li> <li>• <a href="#">Cisco-IOS-XR-infra-xtc-agent-oper.yang</a></li> <li>• <a href="#">Cisco-IOS-XR-infra-xtc-agent-cfg.yang</a></li> </ul> <p>See (<a href="#">GitHub</a>, <a href="#">Yang Data Models Navigator</a>)</p>

You can configure the SR-TE policies as either single or disjoint candidate paths that do not include certain IP addresses or subnets when traffic is routed through the network.

The key benefits of the feature are:

- **Security** - Excluding certain IP addresses or network resources can help protect sensitive resources from unauthorized access or attacks.
- **Performance** - By excluding certain resources, traffic can be directed away from congested parts of the network.
- **Isolation** - Excluding resources can help isolate different parts of the network, preventing issues in one part of the network from affecting others.

## Configuration to exclude network resources during Path Computation

To exclude network resources during path computation for traffic, you must complete these high-level tasks in order:

1. Configure the network resources or IP addresses that you want to exclude from the network list.
2. Associate the excluded network resources to candidate paths for SR-TE or ODN SR-TE policies.

### Configure the network resources or IP addresses to exclude from the network list

Perform the following task to configure a list of IPv4 addresses that you want to exclude from the network resource list:

```
Router(config)#segment-routing traffic-eng
Router(config-sr-te)#resource-list node_resc_list
Router(config-sr-te-rl)#index 1 ipv4 10.10.10.1
Router(config-sr-te-rl)#index 2 ipv4 10.10.10.8
```

#### Running Configuration

```
!
segment-routing
 traffic-eng
  resource-list node_resc_list
    index 1 ipv4 10.10.10.1
    index 2 ipv4 10.10.10.8
!
!
```

### Associate the excluded network resources to candidate paths for SR-TE policies

Perform the following task to associate the excluded IPv4 addresses to one or more candidate paths for SR-TE policies:

```
Router(config)#segment-routing traffic-eng
Router(config-sr-te)#policy dynamic pcep_policy
Router(config-sr-te-policy)#candidate-paths
Router(config-sr-te-policy-path)#preference 100
Router(config-sr-te-policy-path-pref)#constraints resources exclude resource-list
node_resc_list
```

#### Running Configuration



```

!
segment-routing
 traffic-eng
  policy dynamic_pcep_policy
    candidate-paths
      preference 100
      constraints
        resources
          exclude resource-list node_resc_list
    !
  !
!
!
!
!
!

```

## Verification

```
Router#show segment-routing traffic-eng policy endpoint ipv4 100.2.1.1 color 8001
```

```

Wed Aug 30 22:21:50.014 UTC
SR-TE policy database
-----
Color: 8001, End-point: 100.2.1.1
Name: srte_c_8001_ep_100.2.1.1
Status:
Admin: up Operational: up for 00:00:50 (since Aug 30 22:20:59.341)
Candidate-paths:
Preference: 100 (configuration) (active)
Name: dynamic_pcep_policy
Requested BSID: 8001
PCC info:
Symbolic name: cfg_dynamic_pcep_policy_discr_100
PLSP-ID: 14042
Constraints:
Protection Type: protected-preferred
Maximum SID Depth: 12
Exclude Resources: node_resc_list
10.10.10.1
10.10.10.8
Dynamic (pce 100.7.1.1) (valid)
Metric Type: TE, Path Accumulated Metric: 440
SID[0]: 41111 [Adjacency-SID, 101.1.5.1 - 101.1.5.2]
SID[1]: 21600 [Prefix-SID, 100.6.1.1]
SID[2]: 41600 [Adjacency-SID, 101.2.6.2 - 101.2.6.1]
Attributes:
Binding SID: 8001
Forward Class: Not Configured
Steering labeled-services disabled: yes
Steering BGP disabled: no
IPv6 caps enable: yes
Invalidation drop enabled: no
Max Install Standby Candidate Paths: 0

```

## Associate the excluded network resources to candidate paths for ODN SR-TE policies

Perform the following task to associate the excluded IPv4 addresses for ODN SR-TE policies:

```

Router(config)#segment-routing
Router(config-sr)#traffic-eng
Router(config-sr-te)#on-demand color 7001
Router(config-sr-te-color)#constraints resources exclude resource-list node_resc_list

```

## Running Configuration

```

!
segment-routing
 traffic-eng
  on-demand color 7001
  constraints
   resources
    exclude resource-list node_resc_list
  !
!
!
!
!

```

## Verification

```
Router#show segment-routing traffic-eng policy endpoint ipv4 100.2.1.1 color 7001
```

```
Wed Aug 30 22:53:01.079 UTC
```

```
SR-TE policy database
```

```
-----
```

```

Color: 7001, End-point: 100.2.1.1
Name: srte_c_7001_ep_100.2.1.1
Status:
  Admin: up   Operational: up for 00:31:56 (since Aug 30 22:21:04.869)
Candidate-paths:
  Preference: 200 (BGP ODN) (inactive) (shutdown)
  Requested BSID: dynamic
  Constraints:
    Protection Type: protected-preferred
    Maximum SID Depth: 12
    Exclude Resources: node_resc_list
    10.10.10.1
    10.10.10.8
  Dynamic (inactive)
    Metric Type: IGP,   Path Accumulated Metric: 0
  Preference: 100 (BGP ODN) (active)
  Requested BSID: dynamic
  PCC info:
    Symbolic name: bgp_c_7001_ep_100.2.1.1_discr_100
    PLSP-ID: 14044
  Constraints:
    Protection Type: protected-preferred
    Maximum SID Depth: 12
    Exclude Resources: node_resc_list
    10.10.10.1
    10.10.10.8
  Dynamic (pce 100.7.1.1) (valid)
    Metric Type: IGP,   Path Accumulated Metric: 440
    SID[0]: 41111 [Adjacency-SID, 101.1.5.1 - 101.1.5.2]
    SID[1]: 21600 [Prefix-SID, 100.6.1.1]
    SID[2]: 41600 [Adjacency-SID, 101.2.6.2 - 101.2.6.1]
Attributes:
  Binding SID: 51679
  Forward Class: Not Configured
  Steering labeled-services disabled: yes
  Steering BGP disabled: no
  IPv6 caps enable: yes
  Invalidation drop enabled: no
  Max Install Standby Candidate Paths: 0

```

# Configure the Shortest Path for Disjoint Candidate Paths

Table 4: Feature History Table

Feature Name	Release Information	Feature Description
Configure the Shortest Path for Disjoint Candidate Paths	Release 24.1.1	<p>Introduced in this release on: NCS 5500 fixed port routers; NCS 5700 fixed port routers; NCS 5500 modular routers (NCS 5500 line cards; NCS 5700 line cards [Mode: Compatibility; Native]).</p> <p>You can now configure the available disjoint paths for Label Switched Paths (LSPs) to prefer the shortest path between two points in the network. This configuration ensures that traffic is routed along the most efficient route in the network.</p> <p>Previously, you could not configure the shortest path preference for disjoint LSPs.</p> <p>The feature introduces these changes:</p> <p><b>CLI:</b></p> <p>The <b>shortest-path</b> keyword is introduced in the <b>policy candidate-paths constraints disjoint-path</b> command.</p> <p><b>YANG Data Models:</b></p> <ul style="list-style-type: none"> <li>• Cisco-IOS-XR-infra-xtc-oper.yang</li> <li>• Cisco-IOS-XR-infra-xtc-agent-oper.yang</li> <li>• Cisco-IOS-XR-infra-xtc-agent-cfg.yang</li> </ul> <p>See (<a href="#">GitHub</a>, <a href="#">Yang Data Models Navigator</a>)</p>

The configuration enables the available disjoint paths to indicate preference for the shortest path between two points in the network. This way the traffic is contained within specific network planes as per the affinity constraints while still provisioning Label Switched Paths (LSPs) that are diverse from each other to meet the path disjointness requirement.

In earlier releases, if path disjointness was configured for LSPs, the Path Computation Element (PCE) prioritized finding disjoint paths for the LSPs over adhering to the affinity constraints.

## Configure the shortest path for disjoint candidate paths

Perform the following task to indicate the disjoint path preference for the shortest path in the network:

```
Router(config)#segment-routing traffic-eng
Router(config-sr-te)#policy dynamic_pcep_policy_disjoint
Router(config-sr-te-policy)#candidate-paths
Router(config-sr-te-policy-path)#preference 100
Router(config-sr-te-policy-path-pref)#constraints disjoint-path group-id 1 type link
shortest-path
```

### Running Configuration

```
!
segment-routing
 traffic-eng
   policy dynamic_pcep_policy
   candidate-paths
     preference 100
   constraints
     disjoint-path group-id 1 type link shortest-path
!
!
!
!
!
```

### Verification

```
Router#show pce lsp name cfg_dynamic_pcep_policy_disjoint_discr_100 detail
```

Output received:

Wed Aug 30 18:33:57.807 UTC

PCE's tunnel database:

-----

PCC 100.1.1.1:

Tunnel Name: cfg\_dynamic\_pcep\_policy\_disjoint\_discr\_100

Color: 30115

Interface Name: srte\_c\_30115\_ep\_100.2.1.1

LSPs:

LSP[0]:

source 100.1.1.1, destination 100.2.1.1, tunnel ID 9031, LSP ID 24

State: Admin up, Operation active

Setup type: Segment Routing

Binding SID: 30115

Maximum SID Depth: 12

Preference: 100

Bandwidth: requested 0 kbps, applied 0 kbps

Protection type: protected-preferred

Prefix-SID algorithm: 0 (set: 0)

PCEP information:

PLSP-ID 0x36e9, flags: D:1 S:0 R:0 A:1 O:2 C:0

LSP Role: Exclude LSP

State-sync PCE: None

PCC: 100.1.1.1

LSP is subdelegated to: None

Reported path:

Metric type: TE, Accumulated Metric 30

SID[0]: Node, Label 21200, Address 100.2.1.1

Computed path: (Local PCE)

Computed Time: Wed Aug 30 18:31:12 UTC 2023 (00:02:45 ago)

```
Metric type: TE, Accumulated Metric 30
  SID[0]: Node, Label 21200, Address 100.2.1.1
Reverse path: (Local PCE)
None
  Computed Time: Wed Aug 30 18:31:12 UTC 2023 (00:02:45 ago)
Recorded path:
None
Disjoint Group Information:
  Type Link-Disjoint, Group 1 (SP)
SR Policy Association Group:
  Color: 30115, Endpoint: 100.2.1.1
  Policy Name: srte_c_30115_ep_100.2.1.1
  Preference: 100
  CP Name: dynamic_pcep_policy_disjoint
```

## Enable Strict Disjointness for SR-TE policies in the PCE

Table 5: Feature History Table

Feature Name	Release Information	Feature Description
Enable Strict Disjointness for SR-TE Policies in the PCE	Release 24.1.1	<p>Introduced in this release on: NCS 5500 fixed port routers; NCS 5700 fixed port routers; NCS 5500 modular routers (NCS 5500 line cards; NCS 5700 line cards [Mode: Compatibility; Native]).</p> <p>You can now enforce strict disjoint constraints for Label Switched Paths (LSPs) and minimize the risk of a single point of failure that affects multiple LSPs. With this feature, if disjoint paths cannot be found for LSPs, the Path Computation Element (PCE) does not return any path.</p> <p>Previously, enforcing strict disjoint constraints for disjoint paths for LSPs was not possible.</p> <p>The feature introduces these changes:</p> <p><b>CLI:</b></p> <p>The <b>fallback disable</b> keyword is introduced in the <a href="#">segment-routing traffic-eng policy</a> and <a href="#">segment-routing traffic-eng on-demand color</a> commands.</p> <p><b>YANG Data Models:</b></p> <ul style="list-style-type: none"> <li>• <a href="#">Cisco-IOS-XR-infra-xtc-oper.yang</a></li> <li>• <a href="#">Cisco-IOS-XR-infra-xtc-agent-oper.yang</a></li> <li>• <a href="#">Cisco-IOS-XR-infra-xtc-agent-cfg.yang</a></li> </ul> <p>See (<a href="#">GitHub</a>, <a href="#">Yang Data Models Navigator</a>)</p>

When you enable `fallback disable`, the Path Computation Element (PCE) does not return any path for LSPs that are not disjoint if there are no disjoint candidate paths. In other words, when the PCE does not find multiple LSPs that satisfy the disjointness requirement, it returns no path. This indicates that there might be a networking issue that prevents the establishment of the desired redundancy, and you can investigate and address the underlying problem.

Without the option, the PCE can relax disjointness by applying an objective function or use a local policy when no objective function is requested.

Enforcing strict disjointness ensures that LSPs do not share any common links or nodes along their paths, minimizing the risk of a single point of failure affecting multiple LSPs. The feature is critical to maintain network reliability and ensures that traffic is properly routed in the event of a network failure.

## Configure Strict Disjointness in the PCE

### Enable strict disjointness for ODN SR-TE policies

Perform the following steps to enable strict disjointness for ODN SR-TE policies:

```
Router(config)#segment-routing traffic-eng
Router(config-sr-te)#on-demand color 4
Router(config-sr-te-color)#dynamic
Router(config-sr-te-color-dyn)#disjoint-path group-id 1 type node fallback disable
Router(config-sr-te-color-dyn)#commit
```

### Running Configuration

```
segment-routing
 traffic-eng
  on-demand color 4
  dynamic
  disjoint-path group-id 1 type node fallback disable
  !
  !
  !
  !
```

### Enable strict disjointness for SR-TE policies

Perform the following steps to enable strict disjointness for SR-TE policies:

```
Router(config)#segment-routing traffic-eng
Router(config-sr-te)#policy foo
Router(config-sr-te-policy)#color 1 end-point ipv4 10.10.10.1
Router(config-sr-te-policy)#candidate-paths preference 100
Router(config-sr-te-policy-path-pref)#constraints disjoint-path group-id 1 type node fallback
  disable
Router(config-sr-te-policy-path-pref)#commit
```

### Running Configuration

```
segment-routing
 traffic-eng
  policy foo
  color 1 end-point ipv4 10.10.10.1
  candidate-paths
  preference 100
  dynamic
  pcep
  !
  metric
  type latency
  !
  !
  constraints
  disjoint-path group-id 1 type node fallback disable
  !
```

```

!
!
!
!
!

```

### Verification

```

Router#sh pce association
Wed Mar 13 14:38:27.173 PDT

PCE's association database:
-----
Association: Type Node-Disjoint, Group 1, Strict
Associated LSPs:
LSP[0]:
  PCC 10.10.10.1, tunnel name cfg_foo_discr_100, PLSP ID 4, tunnel ID 8, LSP ID 2,
Configured on PCC
LSP[1]:
  PCC 10.10.10.1, tunnel name bgp_c_4_ep_10.10.10.2_discr_100, PLSP ID 1, tunnel ID 5,
LSP ID 3, Configured on PCC
Status: Satisfied

```

## ACL Support for PCEP Connection

PCE protocol (PCEP) (RFC5440) is a client-server model running over TCP/IP, where the server (PCE) opens a port and the clients (PCC) initiate connections. After the peers establish a TCP connection, they create a PCE session on top of it.

The ACL Support for PCEP Connection feature provides a way to protect a PCE server using an Access Control List (ACL) to restrict IPv4 PCC peers at the time the TCP connection is created based on the source address of a client. When a client initiates the TCP connection, the ACL is referenced, and the client source address is compared. The ACL can either permit or deny the address and the TCP connection will proceed or not.

Refer to the Implementing Access Lists and Prefix Lists chapter in the *IP Addresses and Services Configuration Guide for Cisco NCS 5500 Series Routers* for detailed ACL configuration information.

To apply an ACL to the PCE, use the **pce peer-filter ipv4 access-list *acl\_name*** command.

The following example shows how to configure an ACL and apply it to the PCE:

```

pce
 address ipv4 10.1.1.5
 peer-filter ipv4 access-list sample-peer-filter
!
ipv4 access-list sample-peer-filter
 10 permit ipv4 host 10.1.1.6 any
 20 permit ipv4 host 10.1.1.7 any
 30 deny ipv4 any any
!

```

## Anycast SID-Aware Path Computation

This feature allows the SR-TE head-end or SR-PCE to compute a path that is encoded using Anycast prefix SIDs of nodes along the path.



An Anycast SID is a type of prefix SID that identifies a set of nodes and is configured with n-flag clear. The set of nodes (Anycast group) is configured to advertise a shared prefix address and prefix SID. Anycast routing enables the steering of traffic toward multiple advertising nodes, providing load-balancing and redundancy. Packets addressed to an Anycast address are forwarded to the topologically nearest nodes.



**Note** For information on configuring Anycast SID, see [Configuring a Prefix-SID on the IS-IS Enabled Loopback Interface](#) and [Configuring a Prefix-SID on the OSPF-Enabled Loopback Interface](#).

This example shows how Anycast SIDs are inserted into a computed SID list.

The following figure shows 3 isolated IGP domains without redistribution and without BGP 3107. Each Area Border Router (ABR) 1 through 4 is configured with a node SID. ABRs 1 and 2 share Anycast SID 16012 and ABRs 3 and 4 share Anycast SID 16034.

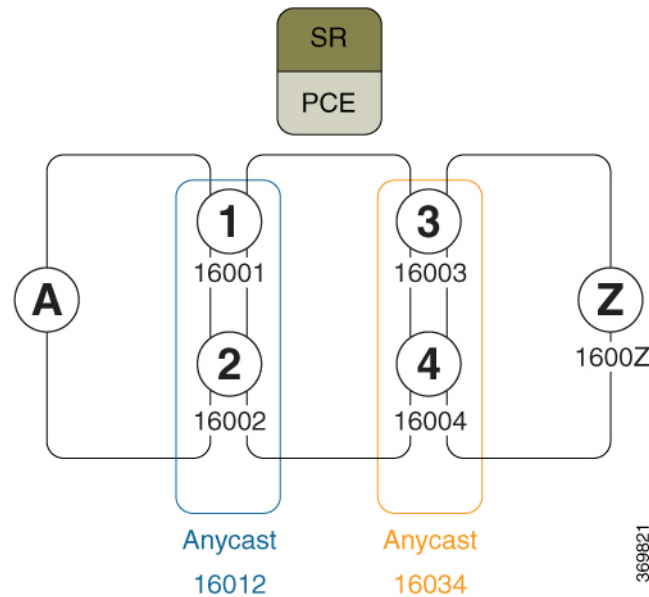

Consider the case where nodes A and Z are provider edge (PE) routers in the same VPN. Node A receives a VPN route with BGP next-hop to node Z. Node A resolves the SR path to node Z based on ODN behaviors with delegation of path computation to SR-PCE.

Before considering Anycast SIDs, the head-end router or SR-PCE computes the SID list.

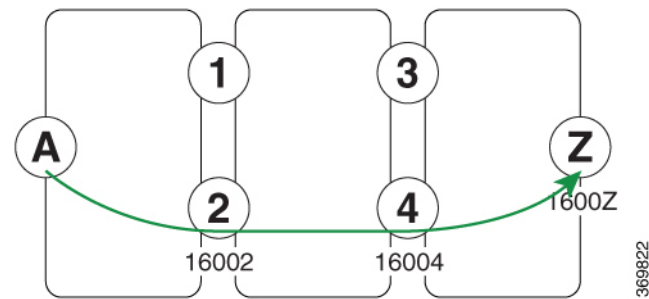

Assume that the computed path from node A to node Z traverses node 2 and node 4. This translates to SID list {16002, 16004, 1600Z} when node SIDs are leveraged to encode the path.

When an Anycast SID-aware path is requested, the path computation algorithm performs the following:

- **Path Computation**—Computes the path according to optimization objectives and constraints
- **Path Encoding**—Encodes the path in a SID list leveraging node-SIDs and adj-SIDs as applicable
- **Anycast SID Replacement**—Reiterates the original SID list by replacing node SIDs with Anycast SIDs present on the nodes along the computed path.

If a node has multiple Anycast SIDs, the algorithm considers them according to their weights. See [Weighted Anycast SIDs](#), on page 28.

- **Optimality Validation**—The new paths are validated against the original optimization objectives and constraints (maintain same cumulative metric as original SID list and do not violate path constraints).
- **Anycast SID Promotion**—If the optimality validation is successful, then the Anycast-encoded SID list is signaled and instantiated in the forwarding.

The following figure depicts cumulative metrics between nodes in the network.

Under these conditions, the optimality check is met, and therefore, the Anycast-encoded SID list from node A to node Z is {16012,16034,1600Z}.

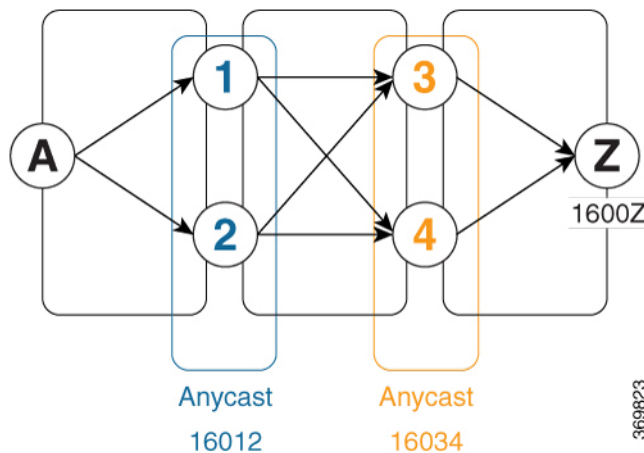

The Anycast SID aware path computation also provides resiliency. For example, if one of the ABRs (in this case, ABR 1) becomes unavailable or unreachable, the path from node A to node Z {16012,16034,1600Z} will still be valid and usable.

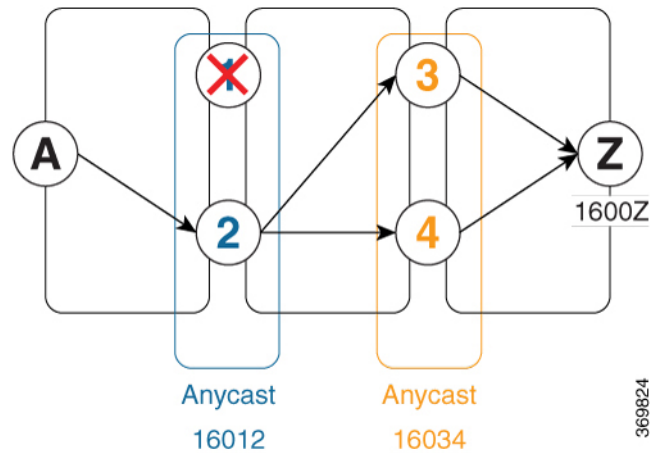

### Configuration Examples

1. Configure Prefix SIDs on the ABR nodes.
  - a. Configure each node with a node SID.
  - b. Configure each group of nodes with a shared Anycast SID.

See [Configuring a Prefix-SID on the IS-IS Enabled Loopback Interface](#) and [Configuring a Prefix-SID on the OSPF-Enabled Loopback Interface](#).

2. Configure SR policies to include Anycast SIDs for path computation using the **anycast-sid-inclusion** command.

This example shows how to configure a local SR policy to include Anycast SIDs for PCC-initiated path computation at the head-end router:

```
Router(config)# segment-routing traffic-eng
Router(config-sr-te)# policy FOO
Router(config-sr-te-policy)# color 10 end-point ipv4 10.1.1.10
Router(config-sr-te-policy)# candidate-paths
Router(config-sr-te-policy-path)# preference 100
Router(config-sr-te-policy-path-pref)# dynamic
Router(config-sr-te-pp-info)# anycast-sid-inclusion
```

### Running Configuration

Use the **anycast-sid-inclusion** command to request Anycast SID-aware path computation for the following SR policy types:

- Local SR policy with PCC-initiated path computation at the head-end router:

```
segment-routing
 traffic-eng
  policy FOO
    color 10 end-point ipv4 10.1.1.10
    candidate-paths
      preference 100
      dynamic
      anycast-sid-inclusion
```

- Local SR policy with PCC-initiated/PCE-delegated path computation at the SR-PCE:

```

segment-routing
traffic-eng
policy BAR
color 20 end-point ipv4 10.1.1.20
candidate-paths
preference 100
dynamic
pcep
anycast-sid-inclusion

```

- On-demand SR policies with a locally computed dynamic path at the head-end, or centrally computed dynamic path at the SR-PCE:

```

segment-routing
traffic-eng
on-demand color 10
dynamic
anycast-sid-inclusion

```

- On-demand SR policies with centrally computed dynamic path at the SR-PCE:

```

segment-routing
traffic-eng
on-demand color 20
dynamic
pcep
anycast-sid-inclusion

```

## Weighted Anycast SIDs

**Table 6: Feature History Table**

Feature Name	Release Information	Feature Description
Weighted Anycast SID-Aware Path Computation	Release 7.3.1	<p>This feature extends Anycast SIDs with weighted nodes.</p> <p>Weighted Anycast nodes advertise a cost (weight) along with the Anycast SID. Traffic is then distributed according to the weights.</p> <p>Weighted Anycast SIDs allow for highly available paths with node redundancy and path optimality that provide Fast Re-Route (FRR) for node failure of service provider edge (PE) routers and ABR/ASBRs nodes in multi-domain networks.</p>

Weighted Anycast nodes advertise a cost along with the Anycast SID. This cost serves as a weight. The native SR path computation algorithms are augmented to compute optimum paths relying on Weighted Anycast SIDs during path encoding. Traffic to the SID is then distributed according to the weights.

The following example shows how node SID, Anycast SID, and Weighted Anycast SID are applied on node 1:

```

router isis 1
 interface Loopback0
  address-family ipv4 unicast
  prefix-sid absolute 16001 // Node SID
  !
  !
 interface Loopback1
  prefix-attributes anycast
  address-family ipv4 unicast
  prefix-sid absolute 16012 // Anycast SID - (prefer node 1 or 2)
  !
  !
 interface Loopback2
  prefix-attributes anycast
  address-family ipv4 unicast
  weight 1
  prefix-sid absolute 17012 // Weighted Anycast SID (prefer node 1)
  !
  !
 interface Loopback3
  prefix-attributes anycast
  address-family ipv4 unicast
  weight 100000
  prefix-sid absolute 18012 // Weighted Anycast SID (prefer node 2)
  !
  !
  !

```

## SR-PCE IPv4 Unnumbered Interface Support

This feature allows IPv4 unnumbered interfaces to be part of an SR-PCE topology database.

An unnumbered IPv4 interface is not identified by its own unique IPv4 address. Instead, it is identified by the router ID of the node where this interfaces resides and the local SNMP index assigned for this interface.

This feature provides enhancements to the following components:

- IGPs (IS-IS and OSPF):
  - Support the IPv4 unnumbered interfaces in the SR-TE context by flooding the necessary interface information in the topology
- SR-PCE:



---

**Note** SR-PCE and path computation clients (PCCs) need to be running Cisco IOS XR 7.0.2 or later.

---

- Compute and return paths from a topology containing IPv4 unnumbered interfaces.
  - Process reported SR policies from a head-end router that contain hops with IPv4 unnumbered adjacencies.
- PCEP extensions for IPv4 unnumbered interfaces adhere to IETF RFC8664 “PCEP Extensions for Segment Routing” (<https://datatracker.ietf.org/doc/rfc8664/>). The unnumbered hops use a Node or

Adjacency Identifier (NAI) of type 5. This indicates that the segment in the explicit routing object (ERO) is an unnumbered adjacency with an IPv4 ID and an interface index.

- SR-TE process at the head-end router:
  - Compute its own local path over a topology, including unnumbered interfaces.
  - Process PCE-computed paths that contain hops with IPv4 unnumbered interfaces.
  - Report a path that contains hops with IPv4 unnumbered interfaces to the PCE.

### Configuration Example

The following example shows how to configure an IPv4 unnumbered interface:

```
RP/0/0/CPU0:rtrA(config)# interface GigabitEthernet0/0/0/0
RP/0/0/CPU0:rtrA(config-if)# ipv4 point-to-point
RP/0/0/CPU0:rtrA(config-if)# ipv4 unnumbered Loopback0
```

To bring up the IPv4 unnumbered adjacency under the IGP, configure the link as point-to-point under the IGP configuration. The following example shows how to configure the link as point-to-point under the IGP configuration:

```
RP/0/0/CPU0:rtrA(config)# router ospf one
RP/0/0/CPU0:rtrA(config-ospf)# area 0
RP/0/0/CPU0:rtrA(config-ospf-ar)# interface GigabitEthernet0/0/0/0
RP/0/0/CPU0:rtrA(config-ospf-ar-if)# network point-to-point
```

### Verification

Use the **show ipv4 interface** command to display information about the interface:

```
RP/0/0/CPU0:rtrA# show ipv4 interface GigabitEthernet0/0/0/0 brief
Tue Apr  2 12:59:53.140 EDT
Interface                               IP-Address      Status          Protocol
GigabitEthernet0/0/0/0                 192.168.0.1    Up              Up
```

This interface shows the IPv4 address of Loopback0.

Use the **show snmp interface** command to find the SNMP index for this interface:

```
RP/0/0/CPU0:rtrA# show snmp interface
Tue Apr  2 13:02:49.190 EDT
ifName : Null0                ifIndex : 3
ifName : Loopback0           ifIndex : 10
ifName : GigabitEthernet0/0/0/0 ifIndex : 6
```

The interface is identified with the pair (IPv4:192.168.0.1, index:6).

Use the **show ospf neighbor** command to display the adjacency:

```
RP/0/0/CPU0:rtrA# show ospf neighbor gigabitEthernet 0/0/0/0 detail
...
Neighbor 192.168.0.4, interface address 192.168.0.4
  In the area 0 via interface GigabitEthernet0/0/0/0
  Neighbor priority is 1, State is FULL, 6 state changes
...
Adjacency SIDs:
  Label: 24001,      Dynamic, Unprotected
```

Neighbor Interface ID: 4

The output of the **show pce ipv4 topology** command is enhanced to display the interface index instead of the IP address for unnumbered interfaces:

```
RP/0/0/CPU0:sr-pce# show pce ipv4 topology
...
Link[2]: unnumbered local index 6, remote index 4
Local node:
  OSPF router ID: 192.168.0.1 area ID: 0 ASN: 0
Remote node:
  TE router ID: 192.168.0.4
  OSPF router ID: 192.168.0.4 area ID: 0 ASN: 0
Metric: IGP 1, TE 1, Latency 1 microseconds
Bandwidth: Total 125000000 Bps, Reservable 0 Bps
Admin-groups: 0x00000000
Adj SID: 24001 (unprotected)
```

The output of **show pce lsp detail** command includes unnumbered hops:

```
RP/0/0/CPU0:sr-pce# show pce lsp detail
...
Reported path:
Metric type: TE, Accumulated Metric 3
SID[0]: Adj unnumbered, Label 24001, local 192.168.0.1(6), remote 192.168.0.4(4)
SID[1]: Adj unnumbered, Label 24002, local 192.168.0.4(7), remote 192.168.0.3(7)
SID[2]: Adj unnumbered, Label 24000, local 192.168.0.3(5), remote 192.168.0.2(5)
Computed path: (Local PCE)
Computed Time: Wed Apr 03 11:01:46 EDT 2019 (00:01:06 ago)
Metric type: TE, Accumulated Metric 3
SID[0]: Adj unnumbered, Label 24001, local 192.168.0.1(6), remote 192.168.0.4(4)
SID[1]: Adj unnumbered, Label 24002, local 192.168.0.4(7), remote 192.168.0.3(7)
SID[2]: Adj unnumbered, Label 24000, local 192.168.0.3(5), remote 192.168.0.2(5)
```

## Inter-Domain Path Computation Using Redistributed SID

Table 7: Feature History Table

Feature Name	Release Information	Feature Description
SR-PCE: Inter-Domain Computation using Redistributed SID (SRTE - BGP-LU Domains Interworking)	Release 7.3.1	This feature is now supported on routers that have the Cisco NC57 line cards installed and operate in the native and compatible modes. To enable the native mode, use the <b>hw-module profile npu native-mode-enable</b> command in the configuration mode. Ensure that you reload the router after configuring the native mode.

A Path Computation Element (PCE) computes SR-TE paths based on SR topology database that stores connectivity, state, and TE attributes of SR network nodes and links. BGP Labeled Unicast (BGP-LU) provides

MPLS transport across IGP boundaries by advertising loopbacks and label binding of impact edge and border routers across IGP boundaries.

This feature adds new functionality to the SR-PCE that enables it to compute a path for remote non-SR end-point device distributed by BGP-LU.

The remote end-point device in the BGP-LU domain is unknown to the SR-PCE. For the SR-PCE to know about the end-point device, the gateway ABR/ASBR learns the end-point prefix via BGP-LU. The prefix is then redistributed to SR-PCE topology database from the gateway ABR/ASBR. SR-PCE then can compute the best path from the head-end device to the selected gateway router.

The following topology shows an SR domain and a BGP-LU domain, with a gateway ABR/ASBR between the two domains.

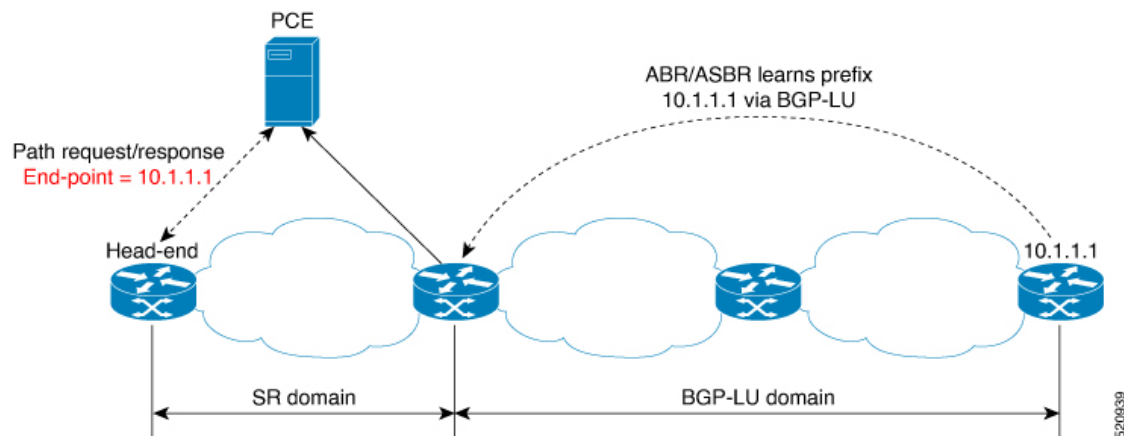

1. The gateway ABR/ASBR is configured with BGP/IGP helper to learn the remote prefix through BGP-LU and redistribute the remote prefix to the IGP helper, then to SR-PCE.
2. The SR-PCE selects the best gateway node to BGP-LU domain and computes the path to reach the remote prefix through the gateway node.
3. The head-end device in the SR domain requests a path to the remote destination and signals the SR profile interworking with the BGP-LU domain.

The BGP-LU prefix advertisement to SR-PCE Traffic Engineer Database (TED) is done by creating an IGP helper on the ABR/ASBR to redistribute BGP-LU prefix information to IGP. IGP then sends the prefix information to the SR-PCE via BGP-LS.

If there are multiple ABR/ASBRs advertising the same remote BGP-LU prefix, the SR-PCE selects the best gateway node to the BGP-LU domain using the accumulative metric from the head-end device to the gateway and the advertised metric from the gateway to the destination.



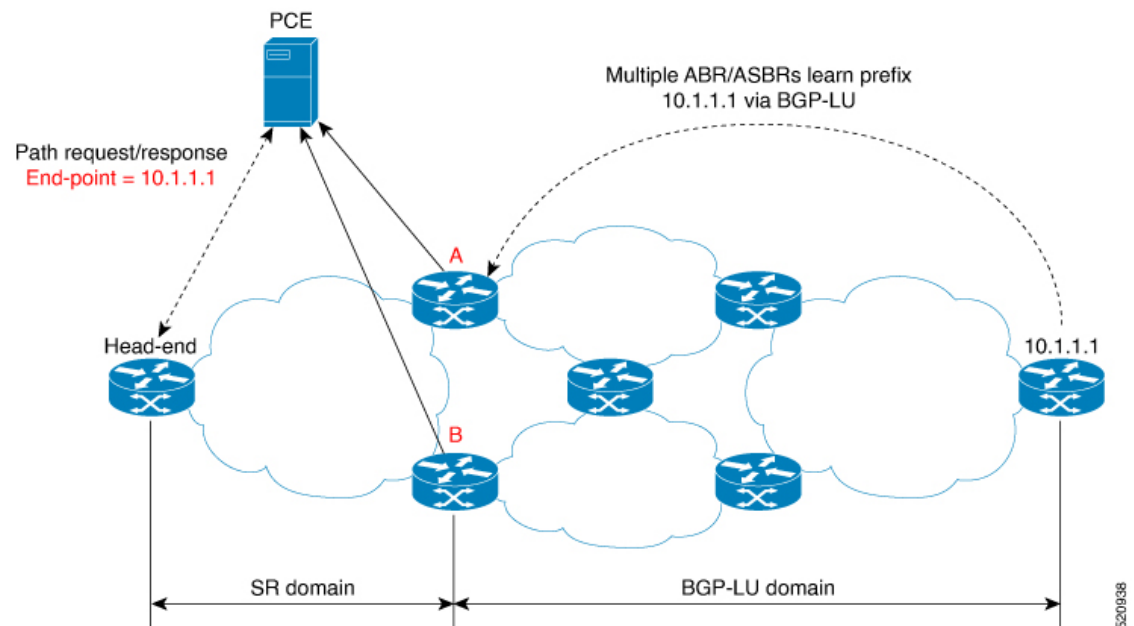

## Example: Inter-Domain Path Computation Using Redistributed SID

The following examples show the configurations for the IGP helper, BGP-LU, and proxy BGP-SR:

### Configuration on the End-Point Device

Configure the end-point device to allocate a label for the BGP-LU prefix on the end-point device:

```
router bgp 3107
  bgp router-id 1.0.0.8
  address-family ipv4 unicast
    network 1.0.0.8/32 route-policy bgplu-com
    allocate-label all

route-policy bgplu-com
  set community (65002:999)
end-policy
```

### Configuration on the Gateway ABR/ASBR

1. Configure the remote prefix set and create the route policy for the BGP-LU domain:

```
prefix-set bgplu
  1.0.0.7/32,
  1.0.0.8/32,
  1.0.0.101/32,
  1.0.0.102/32
end-set
!

route-policy bgp2isis
  if destination in bgplu then
    pass
  else
    drop
  endif
```

```
end-policy
!
end
```

2. Configure the helper IGP instance on the Loopback interface:

```
router isis 101
 is-type level-2-only
 net 49.0001.0000.1010.1010.00
 distribute link-state instance-id 9999
 nsf cisco
 nsf lifetime 120
 address-family ipv4 unicast
 metric-style wide
 maximum-paths 64
 router-id Loopback10
 redistribute bgp 3107 metric 200 route-policy bgp2isis
 segment-routing mpls sr-prefer
!
interface Loopback10 >>> this loopback is for gateway SR-TE node-id
 passive
 address-family ipv4 unicast
 prefix-sid index 2001 explicit-null
```

3. Configure the gateway proxy BGP-SR and SR Mapping Server to allocate SR labels:

```
router bgp 3107
 address-family ipv4 unicast
 segment-routing prefix-sid-map
 allocate-label all

segment-routing
 global-block 16000 23999
 mapping-server
 prefix-sid-map
 address-family ipv4
 1.0.0.7/32 2007
 1.0.0.8/32 2008
 1.0.0.101/32 2101
 1.0.0.102/32 2102
```

## PCE Support for MPLS-TE LSPs

This feature allows Cisco's SR-PCE to act as a Path Computation Element (PCE) for MPLS Traffic Engineering Label Switched Paths (MPLS-TE LSPs).



---

**Note** For more information about MPLS-TE, refer to the "Implementing MPLS Traffic Engineering" chapter in the *MPLS Configuration Guide for Cisco NCS 5500 Series Routers*.

---

The supported functionality is summarized below:

- PCE type: Active Stateful PCE
- MPLS-TE LSP initiation methods:
  - PCE Initiated—An active stateful PCE initiates an LSP and maintains the responsibility of updating the LSP.

- PCC Initiated—A PCC initiates the LSP and may delegate the control later to the Active stateful PCE.
- MPLS-TE LSP metric—Metric optimized by the path computation algorithm:
  - IGP metric
  - TE metric
  - Latency metric
- MPLS-TE LSP constraints—TE LSP attributes to be taken into account by the PCE during path computation:
  - Resource Affinities
  - Path Disjointness
- MPLS-TE LSP parameters:
  - Setup priority—The priority of the TE LSP with respect to taking resources
  - Hold priority—The priority of the TE LSP with respect to holding resources
  - FRR L flag—The "Local Protection Desired" bit. Can be set from an application instantiating an MPLS-TE LSP via SR-PCE. SR-PCE passes this flag to the PCC, and the PCC will enable FRR for that LSP.
  - Signaled Bandwidth—This value can be set from an application instantiating an MPLS-TE LSP via SR-PCE. SR-PCE passes this value to the PCC.
  - Binding SID—A segment identifier (SID) that a headend binds to an MPLS-TE LSP. When the headend receives a packet with active segment (top MPLS label) matching the BSID of a local MPLS-TE LSP, the headend steers the packet into the associated MPLS-TE LSP.

Cisco Crosswork Optimization Engine is an application that leverages the SR-PCE in order to visualize and instantiate MPLS-TE LSPs. For more information, refer to the [Visualize SR Policies and RSVP-TE Tunnels](#) chapter in the [Cisco Crosswork Optimization Engine 1.2.1 User Guide](#).



---

**Note** No extra configuration is required to enable MPLS-TE support at SR-PCE.

---

#### **Example: Configuring a PCEP Session (Stateful Mode) on MPLS-TE PCC**

The following example shows the configuration for an MPLS-TE PCC to establish a PCEP session with a PCE (IPv4 address 10.1.1.100).



---

**Note** MPLS-TE PCC must operate in the stateful PCEP mode when connecting to SR-PCE.

---

The **instantiation** keyword enables the PCC to support MPLS-TE LSP instantiation by PCE (PCE-initiated).

The **report** keyword enables the PCC to report all the MPLS-TE LSPs configured on that node.



---

**Note** PCE-initiated LSPs are automatically reported to all configured PCEs.

---

The **autoroute-announce** keyword enables autoroute-announce globally for all PCE-initiated LSPs on the PCC.

The **redundancy pcc-centric** keywords enable PCC-centric high-availability model for PCE-initiated LSPs. The PCC-centric model changes the default PCC delegation behavior to the following:

- After LSP creation, LSP is automatically delegated to the PCE that computed it.
- If this PCE is disconnected, then the LSP is redelegated to another PCE.
- If the original PCE is reconnected, then the delegation fallback timer is started. When the timer expires, the LSP is redelegated back to the original PCE, even if it has worse preference than the current PCE.

```
mpls traffic-eng
 pce
  peer ipv4 10.1.1.100
  !
  stateful-client
  instantiation
  report
  autoroute-announce
  redundancy pcc-centric
  !
  !
  !
end
```

### Example: Configuring Multiple PCEP Sessions from a PCC Acting as MPLS-TE and SR-TE Headend Toward a Common PCE

The following example shows the configuration for a PCC (IPv4 addresses 10.1.1.1 and 10.1.1.2) to establish two PCEP sessions with a common PCE (IPv4 address 10.1.1.100). One session is configured under MPLS-TE, and the other under SR-TE.



---

**Note** The two PCEP sessions must use a different source address on the PCC when connecting to the same PCE.

---

For more information regarding PCEP configuration at SR-TE PCC, see the *Configure the Head-End Router as PCEP PCC* topic.

```
mpls traffic-eng
 pce
  peer source ipv4 10.1.1.1
  peer ipv4 10.1.1.100
  !
  !
  !
end

segment-routing
 traffic-eng
```

```
pcc
  source-address ipv4 10.1.1.2
  pce address ipv4 10.1.1.100
  !
  !
  !
end
```

## Configuring the North-Bound API on SR-PCE

Table 8: Feature History Table

Feature Name	Release Information	Feature Description
SR-PCE: Stateful North-Bound API for Tree-SID	Release 7.5.1	<p>The SR-PCE provides a north-bound HTTP-based API to allow communication between the SR-PCE and the Cisco Crosswork Optimization Engine.</p> <p>This release adds stateful north-bound APIs to support real-time monitoring of Tree-SID states on the SR-PCE using a subscription model.</p> <p>For more information, refer to the <a href="#">Cisco Crosswork Optimization Engine User Guides</a>.</p>

Table 9: Feature History Table

Feature Name	Release Information	Feature Description
SR-PCE: North-Bound API for SRv6 and Flexible Algorithm in Cisco Optimization Engine (COE) v3.0 release	Release 7.3.2	<p>The SR-PCE provides a north-bound HTTP-based API to allow communication between the SR-PCE and the Cisco Crosswork Optimization Engine.</p> <p>This release adds support for the following:</p> <ul style="list-style-type: none"> <li>• Reporting of Flexible Algorithm participation and definitions</li> <li>• SRv6 topology information (nodes, links, Node uSIDs and Adj uSIDs)</li> <li>• SRv6 uSID list and uB6 SIDs allocated for a policy</li> </ul> <p>For more information, refer to the <a href="#">Cisco Crosswork Optimization Engine User Guides</a>.</p>
SR-PCE: North-Bound API Enhancements for Cisco Optimization Engine (COE) v1.0 release	Release 7.3.1	<p>This feature is now supported on routers that have the Cisco NC57 line cards installed and operate in the native and compatible modes. To enable the native mode, use the <b>hw-module profile npu native-mode-enable</b> command in the configuration mode. Ensure that you reload the router after configuring the native mode.</p>

The SR-PCE provides a north-bound HTTP-based API to allow communication between SR-PCE and external clients and applications.

Over this API, an external application can leverage the SR-PCE for topology discovery, SR policy discovery, and SR policy instantiation.

The Cisco Crosswork Optimization Engine is an application that leverages the SR-PCE. For more information, refer to the [Cisco Crosswork Optimization Engine User Guides](#).

Use the following commands under PCE configuration mode to configure the API to allow communication between SR-PCE and external clients or applications.



---

**Note** The API server is enabled by default when SR-PCE is configured.

---

Command	Description
<b>rest authentication basic</b>	(Optional) Specify basic (plaintext) authentication. By default, authentication is disabled.
<b>rest username</b> <i>password</i> { <b>clear</b>   <b>encrypted</b> } <i>password</i>	Add credentials when connecting to API. <b>Note</b> This command is used only if authentication is configured.
<b>rest sibling ipv4</b> <i>address</i>	Opens a synchronization channel to another PCE in the same high availability (HA) pair. <b>Note</b> For more information regarding SR-PCE HA pairs, refer to the <a href="#">Multiple Cisco SR-PCE HA Pairs</a> chapter of the <a href="#">Cisco Crosswork Optimization Engine 1.2.1 User Guide</a> .

Command	Description
<b>api authentication</b> { <b>basic</b>   <b>digest</b> }	Specify the type of authentication: <ul style="list-style-type: none"> <li>• <b>basic</b> – Use HTTP Basic authentication (plaintext)</li> <li>• <b>digest</b> – Use HTTP Digest authentication (MD5)</li> </ul>
<b>api username</b> <i>password</i> { <b>clear</b>   <b>encrypted</b> } <i>password</i>	Add credentials when connecting to API.
<b>api sibling ipv4</b> <i>address</i>	Opens a synchronization channel to another PCE in the same high availability (HA) pair. <b>Note</b> For more information regarding SR-PCE HA pairs, refer to the <a href="#">Multiple Cisco SR-PCE HA Pairs</a> chapter of the <a href="#">Cisco Crosswork Optimization Engine 1.2.1 User Guide</a> .

### Example: Configuring API on SR-PCE

```
pce
 address ipv4 10.1.1.100
 rest
  user admin
  password encrypted 1304131F0202
  !
  authentication basic
  sibling ipv4 10.1.1.200
  !
  !
end
```

```
pce
 address ipv4 10.1.1.100
 api
```

```

user admin
  password encrypted 1304131F0202
  !
  authentication digest
  sibling ipv4 10.1.1.200
  !
!
end

```

The following example shows the current active connections:

```

RP/0/0/CPU0:pce1# show tcp brief | i 8080
Thu Aug  6 00:40:15.408 PDT
0xe9806fb8 0x60000000      0      0      :::8080      :::0      LISTEN
0xe94023b8 0x60000000      0      0      10.1.1.100:50487      10.1.1.200:8080      ESTAB
0xeb20bb40 0x60000000      0      0      10.1.1.100:8080      10.1.1.200:44401      ESTAB
0xe98031a0 0x60000000      0      0      0.0.0.0:8080      0.0.0.0:0      LISTEN

```

The first and fourth entries show the API server listening for IPv4 and IPv6 connections.

The second and third entries show the established sibling connection between PCE1 (10.1.1.100) and PCE2 (10.1.1.200).