



Connect Router to the Network

- [Port Connection Guidelines](#) , on page 1
- [Interfaces and Port Description](#), on page 2
- [Connect to the Console Port](#), on page 2
- [Create the Initial Router Configuration](#), on page 3
- [Connect to the Management Ethernet Port](#), on page 5
- [Install and Remove Transceiver Modules](#), on page 7
- [Connect Interface Ports](#), on page 20
- [Connecting a Cable to the GNSS Antenna Interface](#) , on page 21
- [Maintain Transceivers and Optical Cables](#), on page 22

Port Connection Guidelines

Depending on the chassis, you can use Quad Small Form-Factor Pluggable Plus (QSFP+), QSFP28, SFP28, and RJ-45 connectors to connect the ports on the router to other network devices.

To prevent damage to the fiber-optic cables, Cisco recommends that you keep the transceivers disconnected from their fiber-optic cables when installing the transceiver in the router. Before removing a transceiver from the router, remove the cable from the transceiver.

To maximize the effectiveness and life of your transceivers and optical cables, do the following:

- Wear an ESD-preventative wrist strap that is connected to an earth ground whenever handling transceivers. The router is typically grounded during installation and provides an ESD port to which you can connect your wrist strap.
- Do not remove and insert a transceiver more often than is necessary. Repeated removals and insertions can shorten its useful life.
- Keep the transceivers and fiber-optic cables clean and dust free to maintain high signal accuracy and to prevent damage to the connectors. Attenuation (loss of light) is increased by contamination and should be kept below 0.35 dB.
 - Clean these parts before installation to prevent dust from scratching the fiber-optic cable ends.
 - Clean the connectors regularly; the required frequency of cleaning depends upon the environment. In addition, clean connectors when they are exposed to dust or accidentally touched. Both wet and dry cleaning techniques can be effective; refer to your site's fiber-optic connection cleaning procedures.

- Do not touch the ends of connectors. Touching the ends can leave fingerprints and cause other contamination.
- Inspect routinely for dust and damage. If you suspect damage, clean and then inspect fiber ends under a microscope to determine if damage has occurred.



Warning **Statement 1051**—Laser Radiation

Invisible laser radiation may be emitted from disconnected fibers or connectors. Do not stare into beams or view directly with optical instruments.

Interfaces and Port Description



Note For location of ports on the routers, see [Network Interfaces](#).

Connect to the Console Port

Before you create a network management connection for the router or connect the router to the network, you must create a local management connection through a console terminal and configure an IP address for the router. You also can use the console to perform the following functions (each of which can be performed through the management interface after you make that connection):

- Configure the router using the command-line interface (CLI).
- Monitor network statistics and errors.
- Configure Simple Network Management Protocol (SNMP) agent parameters.
- Download software updates.

The system console port is an RJ-45 receptacle for connecting a data terminal to perform the initial configuration of NCS 5700 chassis.

Follow this procedure to connect a data terminal to the console port.

Before you begin

- The router must be fully installed in its rack, connected to a power source, and grounded.
- The necessary cabling for the console, management, and network connections must be available.
 - An RJ-45 rollover cable and DB9F/RJ-45 adapter.
 - Network cabling should already be routed to the location of the installed router.

Procedure

- Step 1** Set your terminal to these operational values: 115200 bps, 8 data bits, no parity, 1 stop bits (115200 8N1).
- Step 2** Attach the terminal end of the cable to the interface port on the data terminal.
- Step 3** Attach the other end of the cable to the console port.

Table 1: RJ-45 Straight-through Cable Pin-outs

RJ-45 Pin	Signal
1	—
2	—
3	Tx
4	Ground (GND)
5	GND
6	Rx
7	—
8	—

Create the Initial Router Configuration

You must assign an IP address to the router management interface so that you can then connect the router to the network.

After you boot the router, follow the guided setup/prompts to configure the router. To enable you to connect the router to the network, you can use the default choices for each configuration except for the IP address, which you must provide.



Note These routers are designed to boot up in less than 30 minutes, provided the neighboring devices are in full operational state.



Note Note down the router's unique name. It helps to identify the router among the devices in the network.

Before you begin

- Connect a console device with the router.

- Connect a power source to the router.
- Determine the IP address and netmask needed for the Management interfaces: `MgmtEth0/RP0/CPU0/0` and `MgmtEth0/RP1/CPU0/0`

Procedure

Step 1 Power up the router.

The LEDs on each power supply light up (green) when the power supply units are sending power to the router. The Administrative User Dialog prompt appears.

Step 2 When the system is booted up for the first time, you must enter root-system username. Use the default username and password that is provided to you. Later, you can create new username and password. The following prompt appears:

```
!!!!!!!!!!!!!!!!!!!!!! NO root-system username is configured. Need to configure root-system username.
!!!!!!!!!!!!!!!!!!!!!!
```

```
--- Administrative User Dialog ---
```

```
Enter root-system username:
% Entry must not be null.
```

```
Enter root-system username: cisco
Enter secret:
Use the 'configure' command to modify this configuration.
User Access Verification
```

```
Username: cisco
Password:
```

```
RP/0/RP0/CPU0:ios#
```

Note Username is cisco. Reach out to your accounts team to obtain the password. You can later modify the password in Step 3.

Step 3 Enter a new password to use for this router.

The software checks the security strength of your password and rejects your password if it is not considered to be a strong password. To increase the security strength of your password, make sure that it adheres to the following guidelines:

- At least eight characters
- Minimizes or avoids the use of consecutive characters (such as "abcd")
- Minimizes or avoids repeating characters (such as "aaa")
- Does not contain recognizable words from the dictionary
- Does not contain proper names
- Contains both uppercase and lowercase characters
- Contains numbers as well as letters

- Note** Clear text passwords cannot include the dollar sign (\$) special character.
- Tip** If a password is trivial (such as a short, easy-to-decipher password), the software rejects the password configuration. Be sure to configure a strong password as explained in this step. Passwords are case sensitive. If you enter a strong password, the software asks you to confirm the password.
- Step 4** Reenter the password.
When you enter the same password, the software accepts the password .
- Step 5** Enter the IP address for the management interface.
- Step 6** Enter a network mask for the management interface.
- Step 7** The software asks if you need to edit the configuration. Enter **no** to not edit the configuration.
- Step 8** The software asks if you need to save the configuration. Enter **yes** to save the configuration.
-

Connect to the Management Ethernet Port

The management Ethernet port provides out-of-band management, which enables you to use the command-line interface (CLI) to manage the router by its IP address. This port uses a 10/100/1000 Ethernet connection with an RJ-45 interface.



Note To prevent an IP address conflict, do not connect the management Ethernet port until the initial configuration is complete.

To connect cables to the system management port, attach Category 5 cables directly to the RJ-45 receptacle on the management Ethernet port.



Note To comply with GR-1089-CORE, Railway EN 50121, Smartgrid IEC 61850, and IEEE 1613, the intra-building port(s) of the equipment must use shielded intra-building cabling/wiring that is grounded at both ends.

Before you begin

You must have completed the initial router configuration.

Procedure

- Step 1** Plug the cable directly into the RJ-45 receptacle.
- Step 2** Connect the network end of your RJ-45 cable to a switch, hub, repeater, or other external equipment.
-

Accessing RJ-45 Cable

The RJ-45 cable is available on the Management port. To access the RJ-45 cable, perform the following steps:



Note When the router is fully operational, all ports are populated with cables. It becomes difficult to access the RJ-45 cable using bare hands. Hence the below procedure is recommended to remove RJ-45 cable from the management port.

1. Insert the Philips flat-head screwdriver in between the timing ports.

Figure 1: Inserting a screwdriver between the timing ports

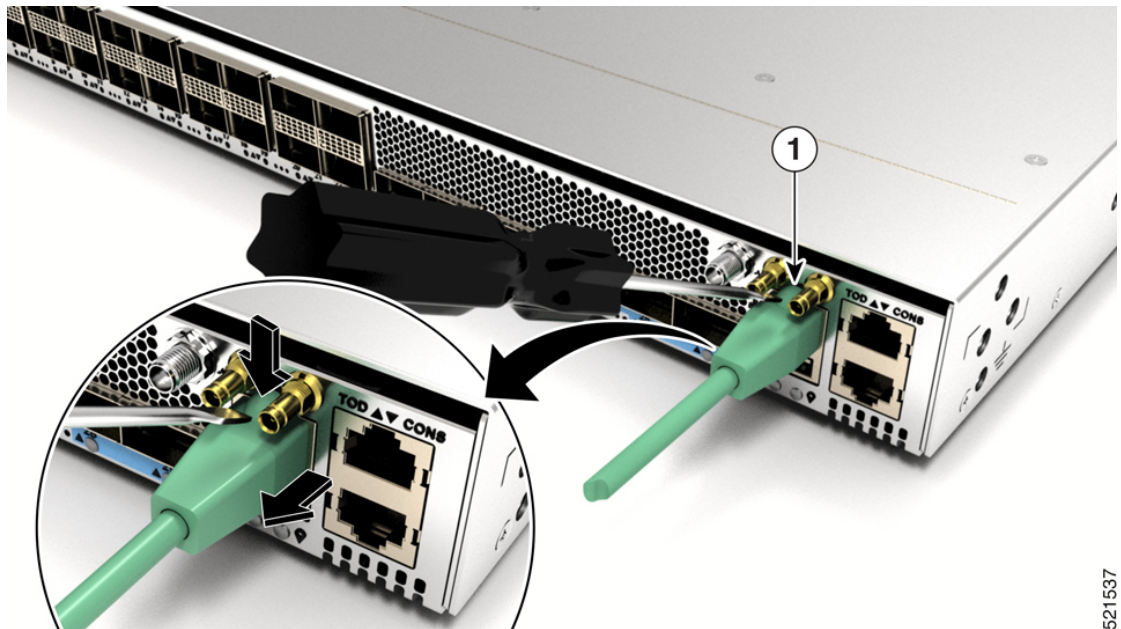

2. Press the clip on the RJ-45 jack downwards and pull the RJ-45 jack from the port. This releases the RJ-45 cable from the port.

Figure 2: Remove RJ-45 Cable from the Jack

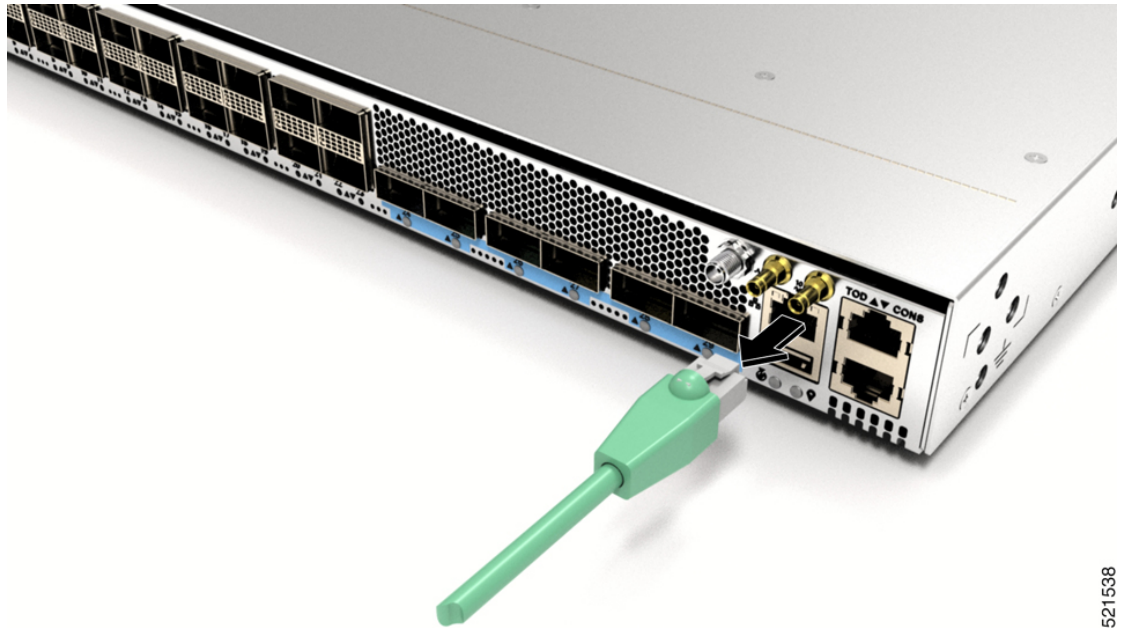

521538

Install and Remove Transceiver Modules

Install and Remove SFP28 and SFP+ Modules

Before you remove or install an SFP28 or SFP+ module, read the installation information in this section.



Note The Cisco NCS 57B1 router has only QSFP-DD sockets, therefore you need QSA module (QSFP to SFP+ Adapter) CVR-QSFP-SFP10G to support SFP+ module.



Note The Cisco NCS-57C3-MOD router has three rows of SFP28 ports. In the top row, install SFP28 transceivers with the electrical connectors on the bottom. In the two bottom rows, install SFP28 transceivers with the electrical connectors on the top.

Figure 3: QSFP to SFP+ Adapter

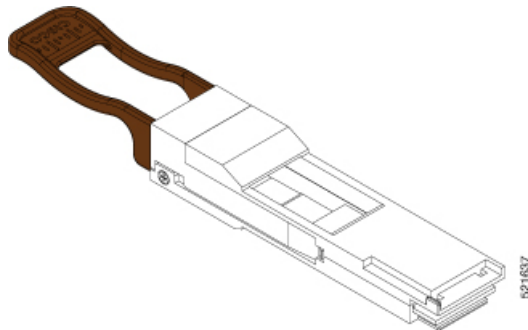

Insert CVR-QSFP-SFP10G in to the QSFP-DD port of the line card, followed by the insertion of the SFP+ pluggable.

Use the **show inventory** command to get details of the Cisco devices that are installed in the router. The adapter details are displayed.



Note The CVR-QSFP-SFP10G support is expected in a future release. Therefore, in release 7.3.15 SFP+ modules can't be used.



Warning **Statement 1051**—Laser Radiation

Invisible laser radiation may be emitted from disconnected fibers or connectors. Do not stare into beams or view directly with optical instruments.



Caution Protect the line card by inserting a clean SFP+ module cage cover, shown in the figure below, into the optical module cage when there is no SFP+ module installed.

Figure 4: SFP+ Module Cage Cover

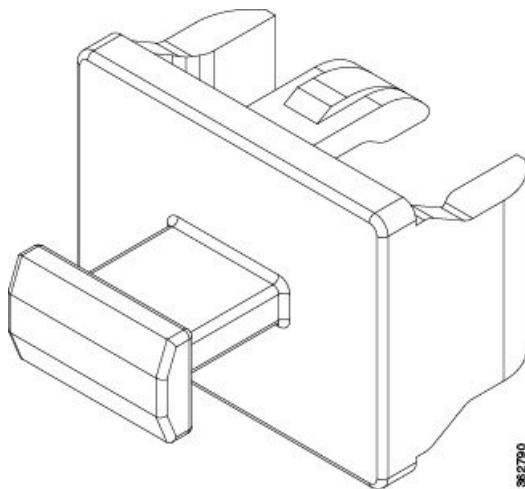



Caution Protect the SFP+ modules by inserting clean dust covers into them after the cables are removed. Be sure to clean the optic surfaces of the fiber cables before you plug them back into the optical ports of another module. Avoid getting dust and other contaminants into the optical ports of your SFP+ modules, because the optics do not work correctly when obstructed by dust.



Caution We strongly recommended that you do not install or remove the SFP+ module with fiber-optic cables attached to it because of the potential of damaging the cable, the cable connector, or the optical interfaces in the module. Disconnect all cables before removing or installing an SFP+ module. Removing and inserting a module can shorten its useful life, so you should not remove and insert modules any more than is absolutely necessary.



Note When installing an SFP+ module, you should hear a click as the triangular pin on the bottom of the module snaps into the hole in the receptacle. The click indicates that the module is correctly seated and secured in the receptacle. Verify that the modules are completely seated and secured in their assigned receptacles on the line card by firmly pushing on each SFP+ module.

Bale Clasp SFP+ Module

The bale clasp SFP+ module has a clasp that you use to remove or install the module (see the figure below).

Figure 5: Bale Clasp SFP+ Module

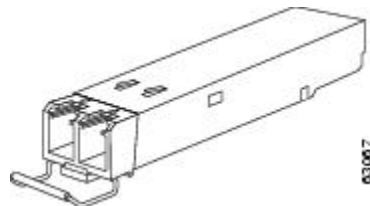

Install a Bale Clasp SFP+ Module

To install this type of SFP+ module, follow these steps:

Procedure

- Step 1** Attach an ESD-preventive wrist or ankle strap and follow its instructions for use.
- Step 2** Close the bale clasp before inserting the SFP+ module.
- Step 3** Insert the QSA module (CVR-QSFP-SFP10G) in to the port. Line up the SFP+ module with the QSA module and slide it into the module.

Note When installing an SFP+ module, you should hear a click as the triangular pin on the bottom of the SFP+ module snaps into the hole in the receptacle. This click indicates that the module is correctly seated and secured in the receptacle. Verify that the SFP+ modules are completely seated and secured in their assigned receptacles on the line card by firmly pushing on each SFP+ module. Use the QSA adapter for using SFP+ modules.

Remove a Bale Clasp SFP+ Module

To remove this type of SFP+ module, follow these steps:

Procedure

- Step 1** Attach an ESD-preventive wrist or ankle strap and follow its instructions for use.
- Step 2** Disconnect and remove all interface cables from the ports; note the current connections of the cables to the ports on the line card.
- Step 3** Open the bale clasp on the SFP+ module with your index finger, as shown in the figure below. If the bale clasp is obstructed and you cannot use your index finger to open it, use a small flat-blade screwdriver or other long, narrow instrument to open the bale clasp.
- Step 4** Grasp the SFP+ module between your thumb and index finger and carefully remove it from the port, as shown in the figure below.

Note This action must be performed during your first instance. After all the ports are populated, this may not be possible.

Figure 6: Removing a Bale Clasp SFP+ Module

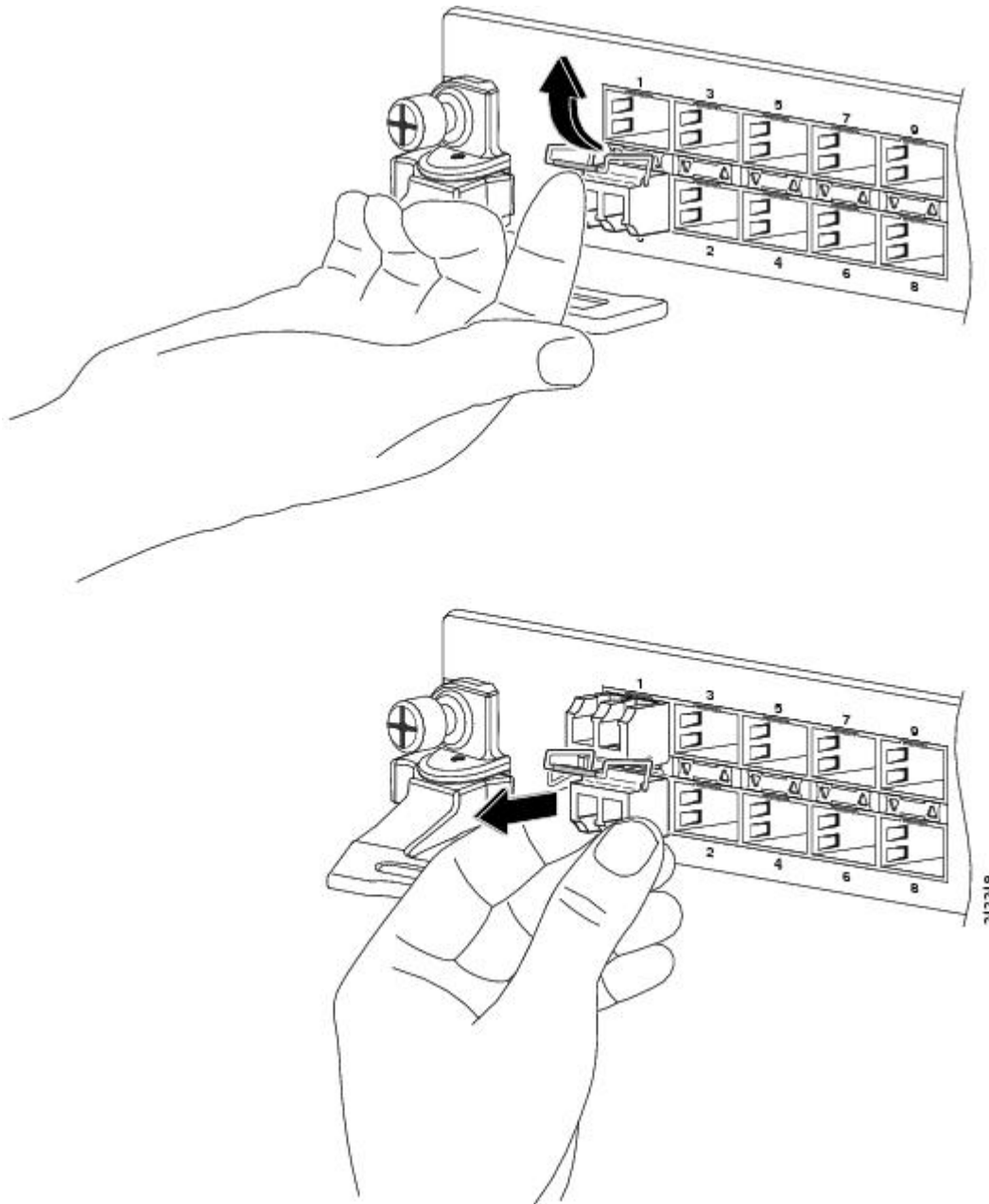

- Step 5** Place the removed SFP+ module on an antistatic mat, or immediately place it in a static shielding bag if you plan to return it to the factory.
- Step 6** Protect your line card by inserting a clean SFP+ module cage covers into the optical module cage when there is no SFP+ module installed.

Install and Remove QSFP-DD Transceiver Modules

This section provides the installation, cabling, and removal instructions for the QSFP-DD transceiver modules. The modules are hot-swappable I/O devices that connect the system's module port electrical circuitry with either a copper or a fiber-optic network.

The following figure shows a 400-Gigabit QSFP-DD optical transceiver. The transceiver is used primarily in short reach applications in switches, routers, and data center equipment where it provides higher density than SFP+ modules. The 100GE/400GE QSFP-DD optical transceiver and 100-Gigabit QSFP28 optical transceiver are similar to the 40-Gigabit QSFP+ optical transceiver.

Figure 7: 400-Gigabit QSFP-DD Transceiver Module - Front view

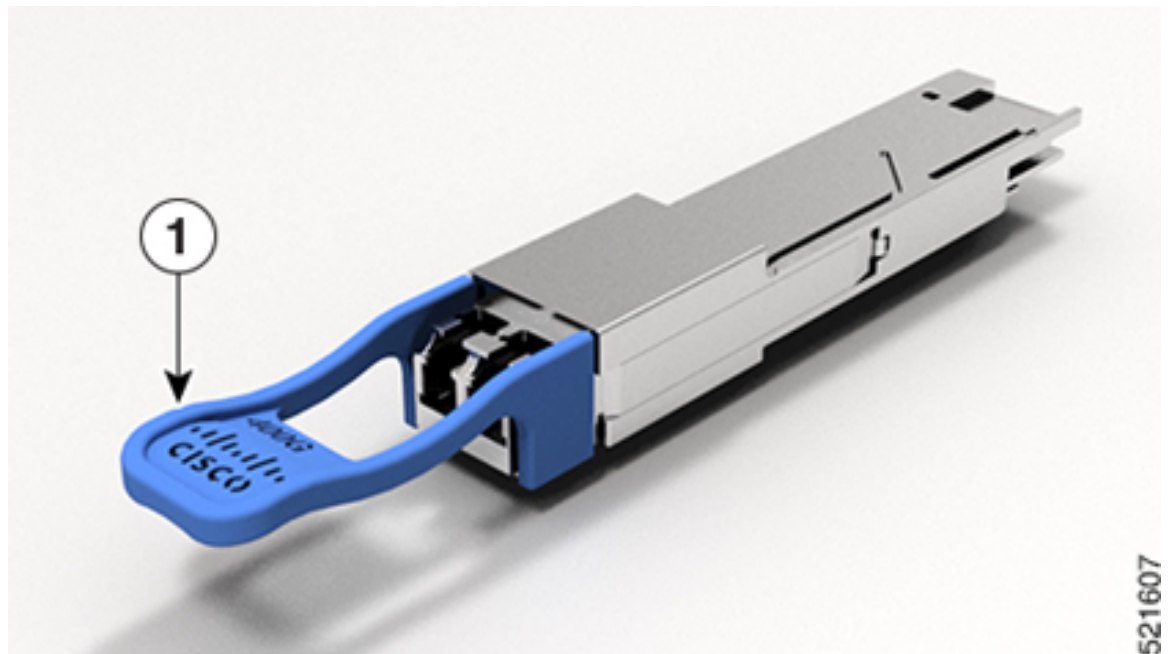
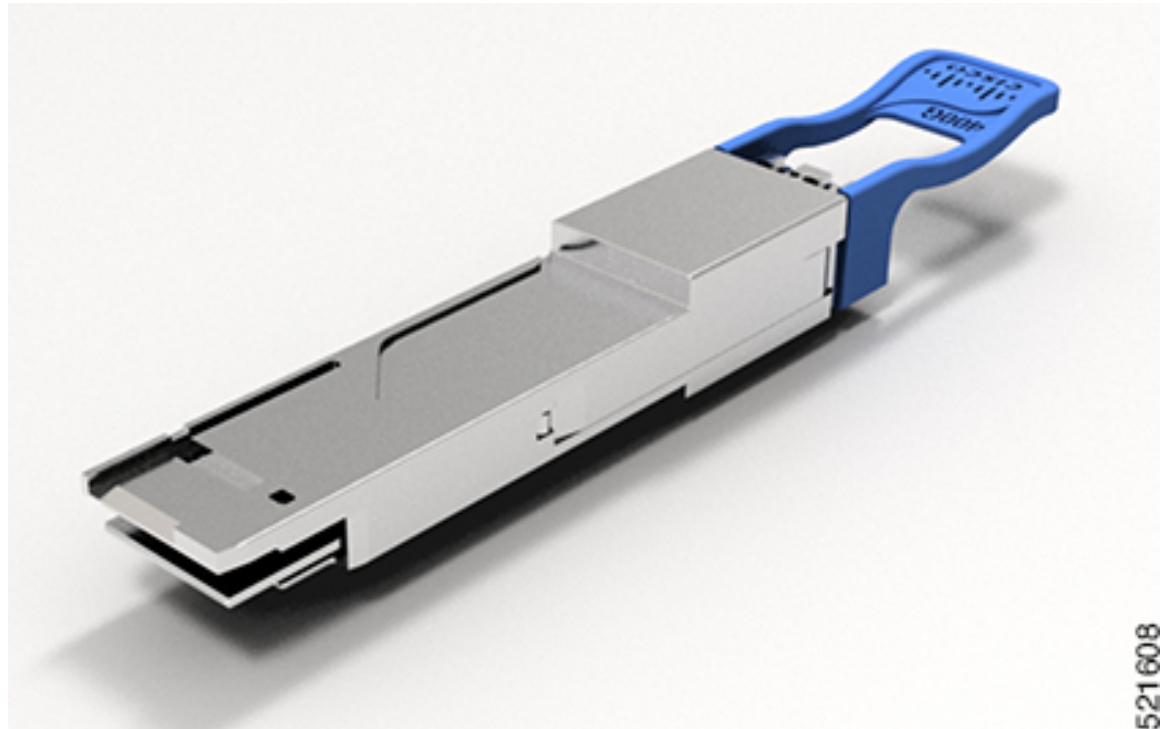

Figure 8: 400-Gigabit QSFP-DD Transceiver Module - Rear view



1	Pull-tab latch.
---	-----------------



Caution The QSFP-DD transceiver module is a static-sensitive device. Always use an ESD wrist strap or similar individual grounding device when handling QSFP-DD transceiver modules or coming into contact with system modules.

The QSFP-DD transceiver module has a pull-tab latch.

To install the QSFP-DD transceiver module, follow these steps:

Before you begin

You need these tools to install the transceiver modules:

- Wrist strap or other personal grounding device to prevent ESD occurrences.
- Antistatic mat or antistatic foam to set the transceiver on.
- Fiber-optic end-face cleaning tools and inspection equipment. See [Inspection and Cleaning Procedures for Fiber-Optic Connections](#).

Procedure

- Step 1** Attach an ESD wrist strap to yourself and a properly grounded point on the chassis or the rack.
- Step 2** Remove the QSFP-DD transceiver module from its protective packaging.
- Step 3** Check the label on the QSFP-DD transceiver module body to verify that you have the correct model for your network.

Note Do not remove the dust plug until you're ready to attach the network interface cable.

- Step 4** Hold the QSFP-DD transceiver module by the pull-tab.
- Step 5** Align the QSFP-DD transceiver module in front of the module's transceiver socket opening and carefully slide the transceiver into the socket until the transceiver contact with the socket electrical connector.

Figure 9: Inserting QSFP-DD Transceiver Module

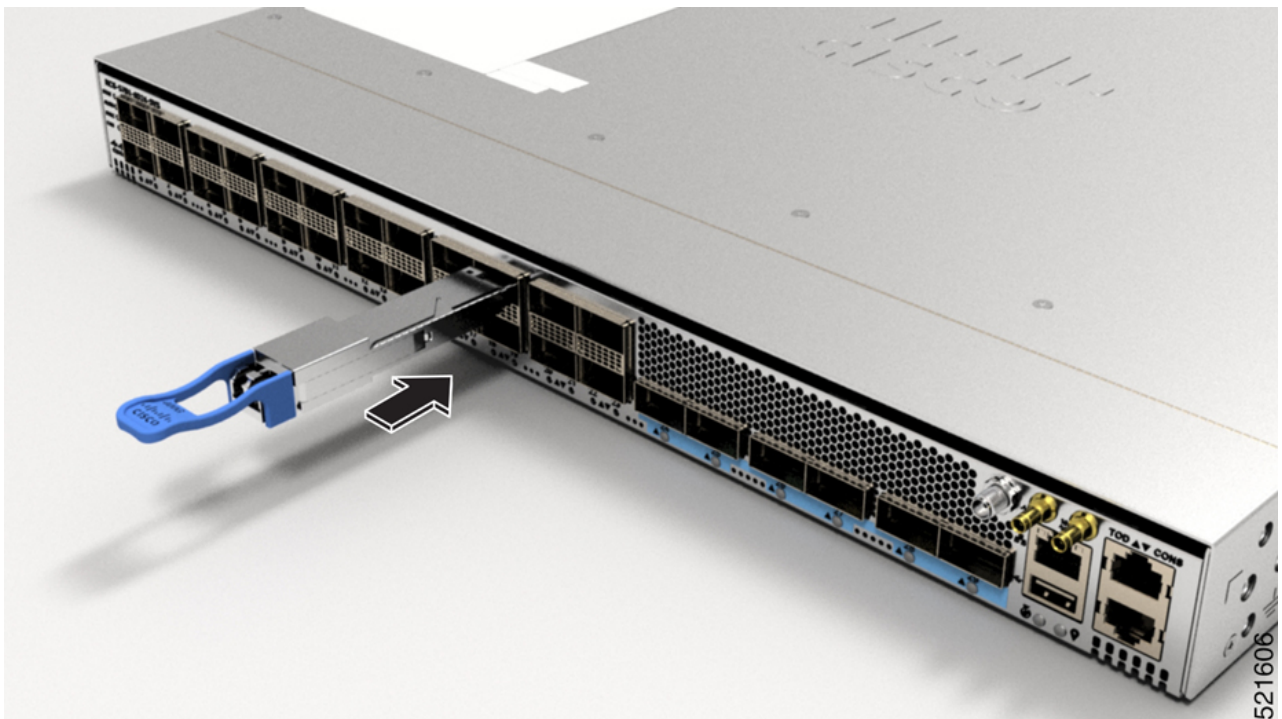

- Step 6** Holding the pull-tab, fully seat the transceiver in the module's transceiver socket until it clicks.

Install and Remove QSFP+/QSFP28 Transceiver Modules

This section provides the installation, cabling, and removal instructions for the 40-Gigabit Quad Small Form-Factor Pluggable Plus (QSFP+) and 100 Gigabit (QSFP28) transceiver modules. The modules are hot-swappable input/output (I/O) devices that connect the system's module port electrical circuitry with either a copper or a fiber-optic network.

The following figure shows the 40-Gigabit optical QSFP+ transceiver. The transceiver is used primarily in short reach applications in switches, routers, and data center equipment where it provides higher density than SFP+ modules. The 100-Gigabit optical QSFP28 transceiver is similar to the 40-Gigabit optical QSFP transceiver.

Figure 10: 40-Gigabit QSFP+ Transceiver Module (Optical)

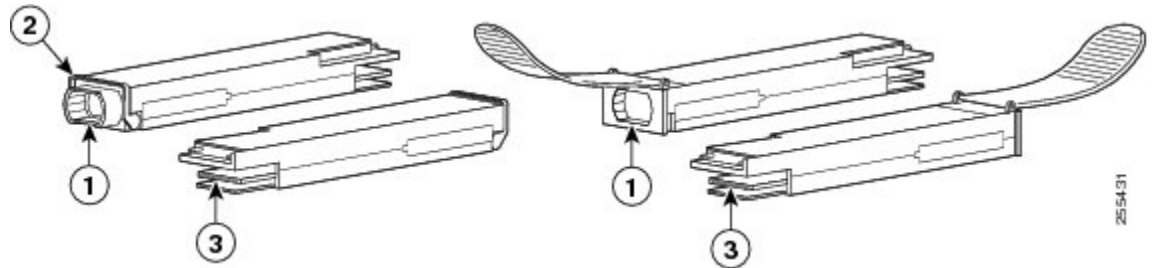

1	40GBASE QSFP+ transceiver body	3	Electrical connection to the module circuit
2	Bail-clasp latch		

Overview

The 40-Gigabit (GE) QSFP+ and 100 Gigabit (QSFP28) transceiver module is a hot-swappable, parallel fiber-optical module with 4 independent optical transmit and receive channels. These channels can terminate in another 40-Gigabit QSFP+ transceiver, or the channels can be broken out to 4 separate 10-Gigabit SFP+ transceivers. The QSFP+ transceiver module connects the electrical circuitry of the system with an optical external network.

The following figure shows the 40-Gigabit optical QSFP+ transceiver. The transceiver is used primarily in short reach applications in switches, routers, and data center equipment where it provides higher density than SFP+ modules. The 100-Gigabit optical QSFP28 transceiver is similar to the 40-Gigabit optical QSFP transceiver.

Figure 11: 40-Gigabit QSFP+ Transceiver Module (Optical)

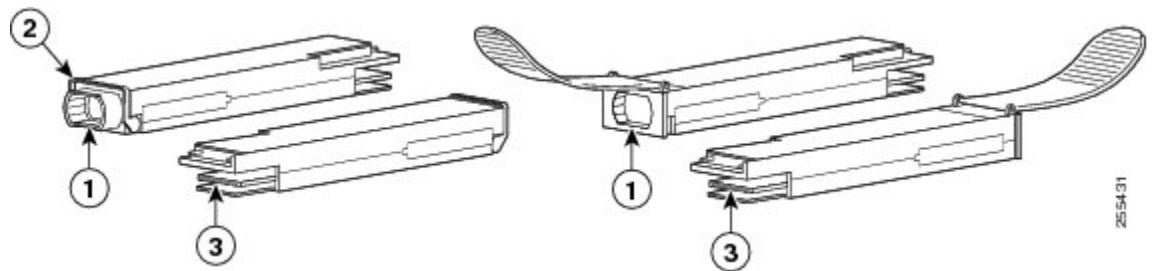

1	40GBASE QSFP+ transceiver body	3	Electrical connection to the module circuit
2	Bail-clasp latch		

Required Tools and Equipment

You need these tools to install the 40-Gigabit QSFP+ / 100-Gigabit QSFP28 transceiver modules:

- Wrist strap or other personal grounding device to prevent ESD occurrences.

- Antistatic mat or antistatic foam to set the transceiver on.
- Fiber-optic end-face cleaning tools and inspection equipment.

Installing the 40-Gigabit QSFP+ or 100-Gigabit Transceiver Module

The QSFP+ or QSFP28 transceiver module can have either a bail-clasp latch or a pull-tab latch. Installation procedures for both types of latches are provided.



Caution The QSFP+ or QSFP28 transceiver module is a static-sensitive device. Always use an ESD wrist strap or similar individual grounding device when handling QSFP+ or QSFP28 transceiver modules or coming into contact with system modules.

To install an QSFP+ or QSFP28 transceiver module, follow these steps:

Procedure

-
- Step 1** Attach an ESD wrist strap to yourself and a properly grounded point on the chassis or the rack.
 - Step 2** Remove the QSFP+ or QSFP28 transceiver module from its protective packaging.
 - Step 3** Check the label on the QSFP+ or QSFP28 transceiver module body to verify that you have the correct model for your network.
 - Step 4** For optical QSFP+ or QSFP28 transceiver modules, remove the optical bore dust plug and set it aside.
 - Step 5** For QSFP+ or QSFP28 transceiver modules equipped with a pull-tab, hold the transceiver so that the identifier label is on the top.
 - Step 6** For QSFP+ or QSFP28 transceiver modules equipped with a bail-clasp latch, keep the bail-clasp aligned in a vertical position.
 - Step 7** Align the QSFP+ or QSFP28 transceiver module in front of the module's transceiver socket opening and carefully slide the QSFP+ or QSFP28 transceiver into the socket until the transceiver makes contact with the socket electrical connector (see the figure below).

Figure 12: Installing the 40-Gigabit QSFP+ or 100-Gigabit QSFP28 Transceiver Module (Optical Transceiver Equipped with a Bail-Clasp Latch Shown)

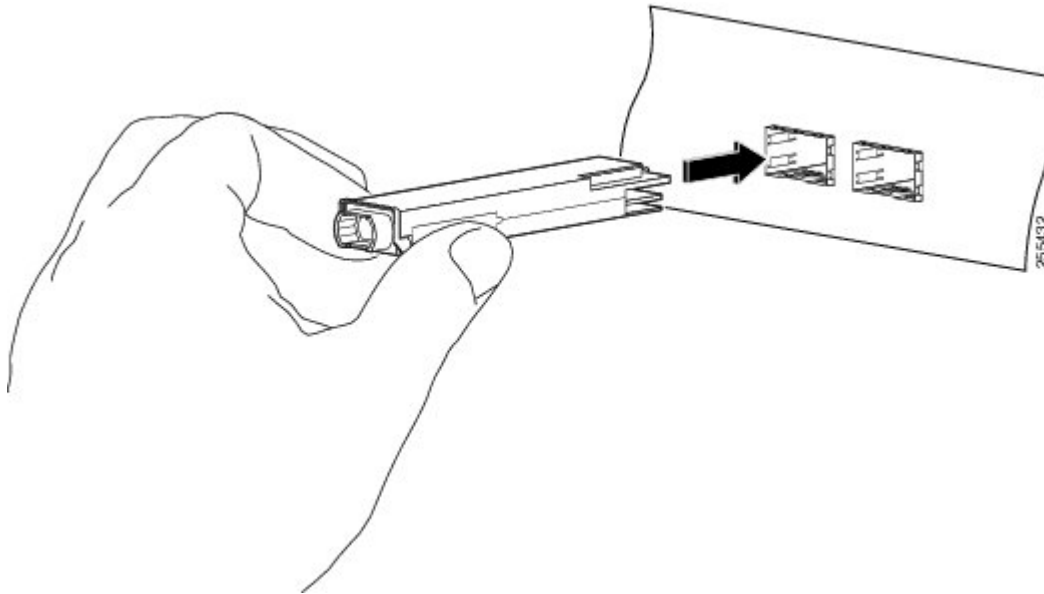

Step 8 Press firmly on the front of the QSFP+ or QSFP28 transceiver module with your thumb to fully seat the transceiver in the module's transceiver socket (see the below figure).

Caution If the latch is not fully engaged, you might accidentally disconnect the QSFP+ or QSFP28 transceiver module.

Figure 13: Seating the 40-Gigabit QSFP+ or 100-Gigabit QSFP28 Transceiver Module (Optical Transceiver Equipped with a Bail-Clasp Latch Shown)

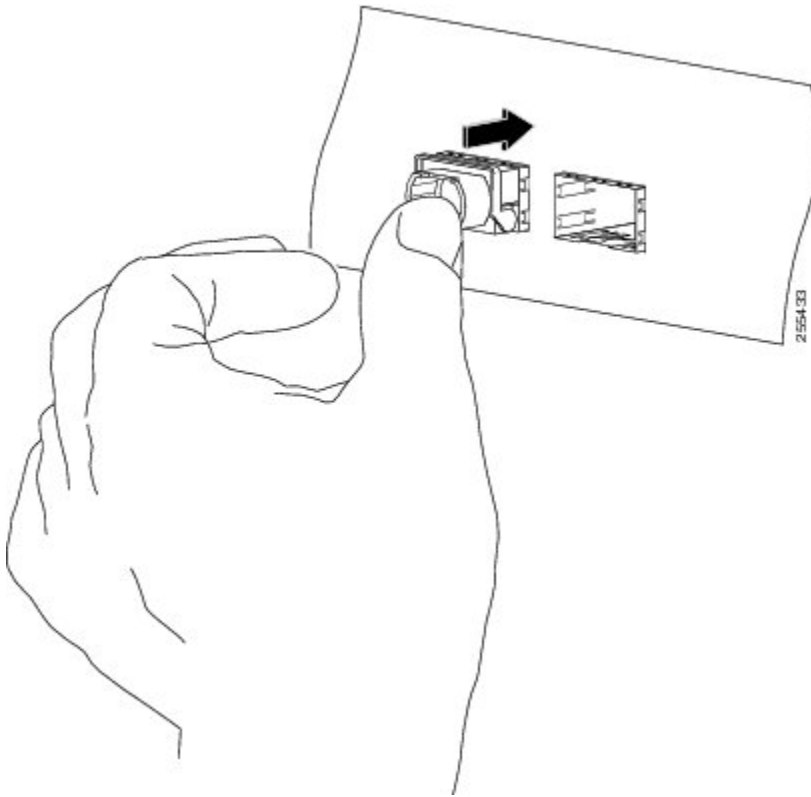

- Step 9** For optical QSFP+ or QSFP28 transceiver modules, reinstall the dust plug into the QSFP+ or QSFP28 transceivers optical bore until you are ready to attach the network interface cable. Do not remove the dust plug until you are ready to attach the network interface cable.

Attach the Optical Network Cable

Before you begin

Before you remove the dust plugs and make any optical connections, follow these guidelines:

- Keep the protective dust plugs installed in the unplugged fiber-optic cable connectors and in the transceiver optical bores until you are ready to make a connection.
- Inspect and clean the MPO connector end faces just before you make any connections.
- Grasp the MPO connector only by the housing to plug or unplug a fiber-optic cable.



Note 40-Gigabit QSFP+ or QSFP28 transceiver modules are keyed to prevent incorrect insertion.



Note The multiple-fiber push-on (MPO) connectors on the optical QSFP+ or QSFP28 transceivers support network interface cables with either physical contact (PC) or ultra-physical contact (UPC) flat polished face types. The MPO connectors on the optical QSFP+ or QSFP28 transceivers do not support network interface cables with an angle-polished contact (APC) face type.

Procedure

- Step 1** Remove the dust plugs from the optical network interface cable MPO connectors. Save the dust plugs for future use.
- Step 2** Inspect and clean the MPO connector's fiber-optic end faces.
- Step 3** Remove the dust plugs from the QSFP+ or QSFP28 transceiver module optical bores.
- Step 4** Immediately attach the network interface cable MPO connectors to the QSFP+ or QSFP28 transceiver module (see the figure below).

Figure 14: Cabling a 40-Gigabit QSFP+ or QSFP28 Transceiver Module

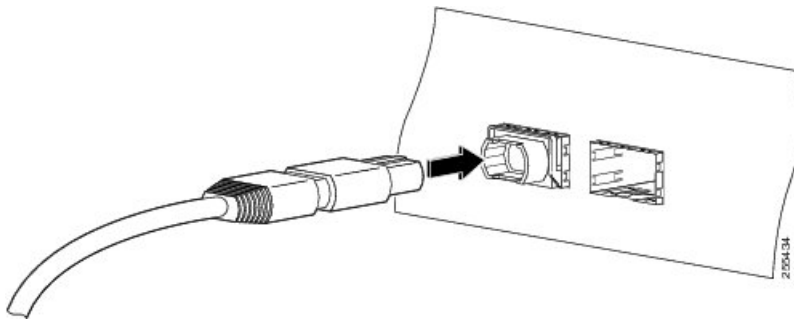

Removing the 40-Gigabit QSFP+ or 100-Gigabit QSFP28 Transceiver Module



Caution The QSFP+ or QSFP28 transceiver module is a static-sensitive device. Always use an ESD wrist strap or similar individual grounding device when handling QSFP+ or QSFP28 transceiver modules or coming into contact with modules.

To remove a QSFP+ or QSFP28 transceiver module, follow these steps:

Procedure

- Step 1** For optical QSFP+ or QSFP28 transceiver modules, disconnect the network interface cable from the QSFP+ or QSFP28 transceiver connector.
- Step 2** For QSFP+ or QSFP28 transceiver modules equipped with a bail-clasp latch (see the below figure, top view):
 - a) Pivot the bail-clasp down to the horizontal position.

- b) Immediately install the dust plug into the transceivers optical bore.
- c) Grasp the sides of the QSFP+ or QSFP28 transceiver and slide it out of the module socket.

Step 3 For QSFP+ or QSFP28 transceivers equipped with a pull tab latch (see the below figure, bottom view):

- a) Immediately install the dust plug into the transceiver's optical bore.
- b) Grasp the tab and gently pull to release the transceiver from the socket.
- c) Slide the transceiver out of the socket.

Figure 15: Removing the 40-Gigabit QSFP+ or 100-Gigabit QSFP28 Transceiver Module

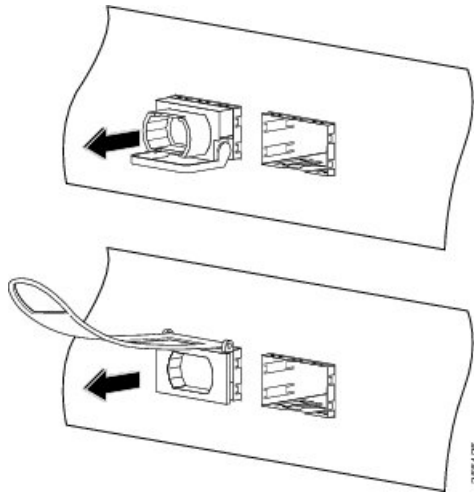

Step 4 Place the QSFP+ or QSFP28 transceiver module into an antistatic bag.

Connect Interface Ports

You can connect optical interface ports on line cards with other devices for network connectivity.

Connect a Fiber-Optic Port to the Network

Depending on the line card model that you are using, you can use either QSFP+ or QSFP28 transceivers. Some transceivers work with fiber-optic cables that you attach to the transceivers and other transceivers work with pre-attached copper cables. When installing fiber-optic cables for a port, you must install SFP transceivers for 1-Gigabit optical ports or install SFP+ transceivers for 10-Gigabit optical ports or QSFP+ transceivers for 100-Gigabit ports before installing the fiber-optic cable in the transceivers.



Caution Removing and installing a transceiver can shorten its useful life. Do not remove and insert transceivers any more than is absolutely necessary. We recommended that you disconnect cables before installing or removing transceivers to prevent damage to the cable or transceiver.

Disconnect Optical Ports from the Network

When you need to remove fiber-optic transceivers, you must first remove the fiber-optic cables from the transceiver before you remove the transceiver from the port.

Connecting a Cable to the GNSS Antenna Interface

Depending on the router, the GNSS LED is located on the front or the rear side of the router.

Procedure

Step 1 Connect one end of a shielded coaxial cable to the GNSS RF IN port.

Step 2 Connect the other end of the shielded coaxial cable to the GNSS antenna after the primary protector.

Note The GNSS RF In port should have a primary protector installed to meet the Local Safety guidelines. The GNSS RF In coaxial cable shield must be connected to the Facility Equipment Ground through the chassis. The chassis must have the ground wire connected to the Facility Equipment Ground.

GPS Port Pinouts

The platform is capable of receiving or sourcing GPS signals of 1 PPS & 10 MHz. These interfaces are provided by two mini-coax 50-Ohm, 1.0/2.3 DIN series connector on the front panel. Similarly there are two mini-coax 50-Ohm connectors provided in the front panel to output this 1PPS and 10MHz.

The table below summarizes the GPS port pinouts.

Table 2: GPS Port Pinouts

	10 MHz (Input and Output)	1PPS (Input and Output)
Waveform	Input—Sine wave Output—Square wave	Input—Rectangular pulse Output—Rectangular pulse
Amplitude	Input— > 1.7 volt p-p(+8 to +10 dBm) Output— > 2.4 volts TTL compatible	Input— > 2.4 volts TTL compatible Output— > 2.4 volts TTL compatible
Impedance	50 ohms	50 ohms
Pulse Width	50% duty cycle	26 microseconds
Rise Time	Input—AC coupled Output—5 nanoseconds	40 nanoseconds

Maintain Transceivers and Optical Cables

Transceivers and fiber-optic cables must be kept clean and free of dust to maintain high signal accuracy and to prevent damage to the connectors. Attenuation (loss of light) is increased by contamination and should be below 0.35 dB.

Consider the following maintenance guidelines:

- Transceivers are static sensitive. To prevent ESD damage, wear an ESD-preventative wrist strap that is connected to the grounded chassis.
- Do not remove and insert a transceiver any more than is necessary. Repeated removals and insertions can shorten its useful life.
- Keep all optical connections covered when not in use. Clean them before use to prevent dust from scratching the fiber-optic cable ends.
- Do not touch the ends of connectors. Touching the ends would leave fingerprints and cause other contamination.
- Clean the connectors regularly; the required frequency of cleaning depends upon the environment. In addition, clean connectors if they are exposed to dust or have been accidentally touched. Both wet and dry cleaning techniques can be effective; refer to your site's fiber-optic connection cleaning procedures.
- Inspect routinely for dust and damage. Clean and then inspect fiber ends under a microscope to determine whether any damage has occurred.