



Replace Chassis Components



Note The images in this chapter are only for representation purposes, unless specified otherwise. The chassis' actual appearance and size may vary.

- [Replace a Route Processor Card, on page 1](#)
- [Replace a System Controller Module, on page 4](#)
- [Installing and Removing a Blank Line Card , on page 6](#)
- [Replace a Line Card, on page 9](#)
- [Replace a Fan Tray, on page 14](#)
- [Replace Fabric Card, on page 18](#)
- [Replace Power Supplies, on page 26](#)

Replace a Route Processor Card

The router supports up to two redundant route processor cards. When two route processor cards are installed in the router, one acts as an active card and the other as the standby card. When the active route processor card is removed, the router automatically makes the standby route processor card active and the card that you are removing, the standby route processor. If the router has only one route processor card installed, a new route processor can be installed in the empty route processor slot during operation.



Warning **Statement 1029**—Blank Faceplates and Cover Panels

Blank faceplates and cover panels serve three important functions: they prevent exposure to hazardous voltages and currents inside the chassis; they contain electromagnetic interference (EMI) that might disrupt other equipment; and they direct the flow of cooling air through the chassis. Do not operate the system unless all cards, faceplates, front covers, and rear covers are in place.



Note Before replacing the card, you must perform a graceful shutdown of the card to avoid disk corruption.

Watch [Replace a Route Processor Card \(Video\)](#)

Procedure

- Step 1** Open the packaging for the new route processor card, inspect the card for damage, and verify that the card is the same type as the other route processor card installed in the chassis.
- If the card is damaged, alert the Technical Assistance Center (TAC).
- Step 2** If you are installing the card in an empty slot, remove the blank card that is already in that slot by unscrewing its captive screw and pulling it out of the slot. Go to Step 4.
- Step 3** If you are replacing a card that is currently in the chassis, remove the existing card from the chassis by following these steps:
- Disconnect the following cables from the card:
 - Console cable
 - Ethernet Management cable
 - If there are any external drives attached to the card through its USB ports, detach those drives.
 - Run the **hw-module location <loc> shutdown** command in admin EXEC mode, which gracefully shuts down route processor module to prevent any of the file systems from being corrupted.
 - Verify that the route processor Status (STS) LED for the slot that you specified turns off. Also, you can verify that the card is in powered off state running the **show platform** command to verify the status of the card to be **POWERED_OFF**.
 - Slide the middle section of the ejector handle toward the end of the handle and rotate the handle away from the front of the card (see Callouts 1 and 2 in the following figure).

The card unseats its connectors from the midplane and moves slightly out of the chassis.

Figure 1: Remove Route Processor card from Chassis

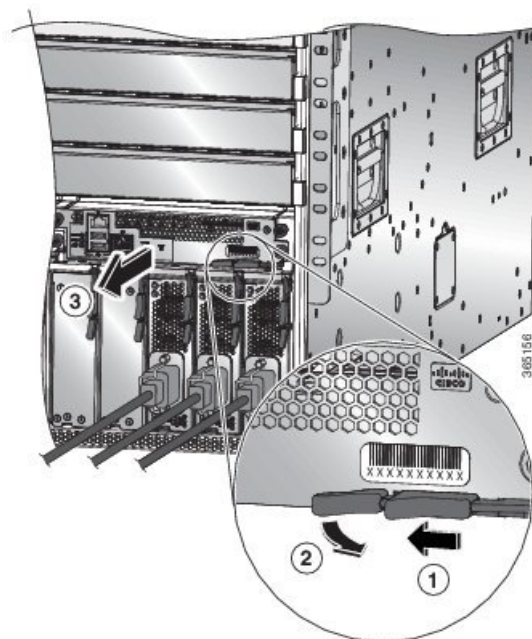

1	Slide the middle handle toward the end of the ejector lever.	2	Rotate the ejector lever away from the card.
3	Pull on the lever to slide the card part way out of the chassis. Release the lever, hold the front of the card and pull the card all the way out of the chassis.		

- f) Use one hand to hold the front of the card, place your other hand under the card to support its weight, pull the card out of the chassis, and set it on an antistatic surface or inside an antistatic bag.

Step 4

To install a new card, follow these steps:

- a) Pull the middle section of the ejector handle toward the end of the handle and rotate the handle away from the front of the card.

This action opens the lever so that the card can be fully inserted into the slot.

- b) Hold the front of the card with one hand and place your other hand under the card to support its weight.
- c) Align the back of the card to the guides in the open route processor slot and slide the card all the way into the slot (see the following figure).

The card stops when its front is about 0.25 inches (0.6 cm) outside the front of the chassis.

Figure 2: Install route processor card into Chassis

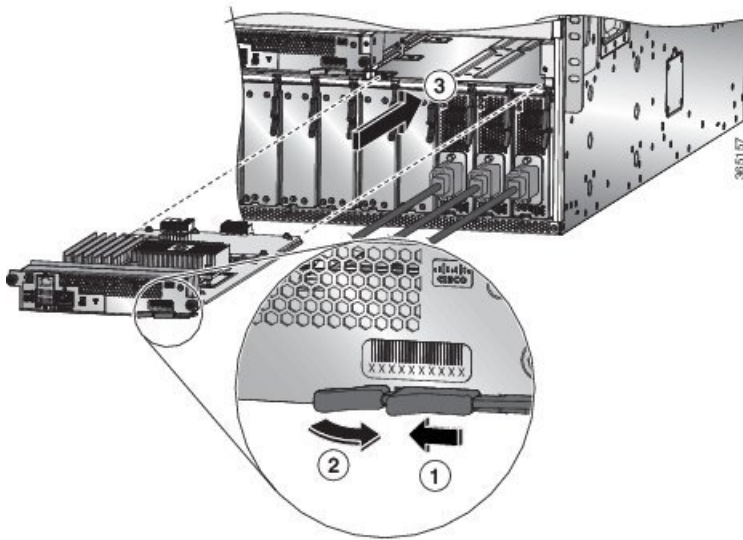

1	Slide the middle handle toward the end of the ejector lever.	3	Slide the back end of the card into the open route processor slot.
2	Rotate the ejector lever away from the card.		

- d) Rotate the lever all the way to the front of the chassis until it locks in place with a click.
Make sure that the other end of the lever engages behind the front of the slot so that the card fully seats onto the connectors on the midplane.
- e) Screw in the two captive screws to secure the card to the chassis. Tighten the screws to 8 in-lb (0.9 N·m) of torque.
- f) Attach the following cables to the card:
 - Console cable—Attach to the Console port.

- Management cable—Attach to the Management Ethernet port.
- g) Verify that the route processor card LEDs turn on and appear as follows:
- The Status (STS) LED blinks in amber color, then turns to solid amber color, and later turns to green color.
 - The Active (ACT) LED is amber or green.

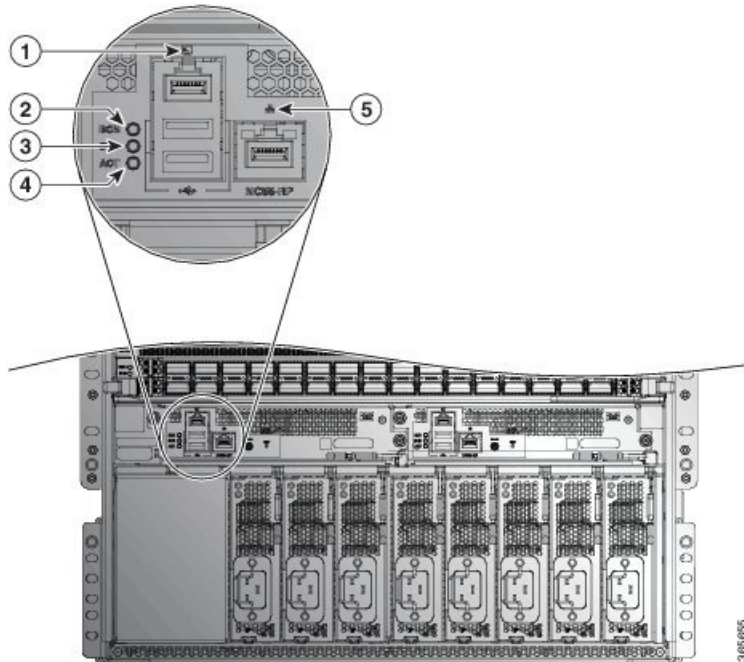

Replace a System Controller Module

The router can operate with one or two system controller modules installed in the chassis. You can replace one system controller module while there is another one installed in the chassis.



Warning Statement 1029—Blank Faceplates and Cover Panels

Blank faceplates and cover panels serve three important functions: they prevent exposure to hazardous voltages and currents inside the chassis; they contain electromagnetic interference (EMI) that might disrupt other equipment; and they direct the flow of cooling air through the chassis. Do not operate the system unless all cards, faceplates, front covers, and rear covers are in place.

Watch [Replace a System Controller Module \(Video\)](#)

Procedure

- Step 1** Open the packaging for the new system controller module and inspect the module for damage. If the module is damaged, alert the Technical Assistance Center (TAC).
- Step 2** If you are installing the module in an empty slot, remove the blank module that is already in that slot by unscrewing its captive screw and pulling it out of the slot. Go to Step 4.
- Step 3** If you are replacing a module that is currently in the chassis, remove the existing module from the chassis by following these steps:
- Run the **hw-module location <loc> shutdown** command in admin EXEC mode, to gracefully shut down the card.
 - Unscrew the two captive screws (one on each side of the module) until the screws are no longer in contact with the chassis.
 - Slide and hold the middle handle on the ejector lever toward the end of the lever.
 - Rotate the ejector lever away from the front of the module.
- As you rotate the lever, the module unseats from the midplane and moves slightly forward.
- Use the lever to pull the module a couple of inches (about 5 cm) out of the slot.
 - Use one hand to hold the front of the module, place your other hand under the module to support its weight, pull the module out of the chassis, and set it on an antistatic surface or inside an antistatic bag.
- Step 4** To install the new module, follow these steps:
- Slide and hold the middle handle on the ejector lever toward the end of the lever (see the following figure).

Figure 3: Removing a System Controller Module from a Chassis

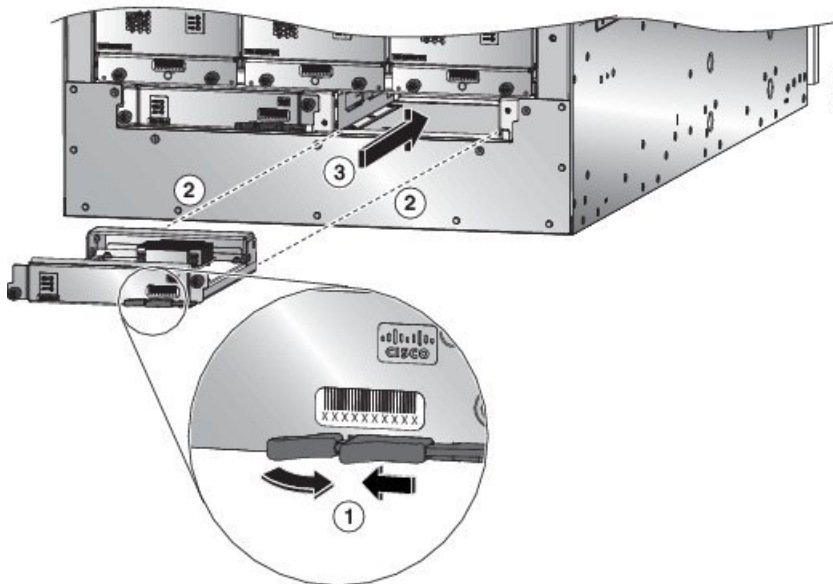

1	Slide the middle handle on the ejector lever to the end of the lever and rotate the lever away from the module.	3	Slide the module all the way into the chassis.
---	---	---	--

2	Align the back of the module to the open slot in the chassis.		
---	---	--	--

- b) Hold the front of the module with one hand and place your other hand under the module to support it.
- c) Align the back of the module to the guides in the open controller slot and slide the module all the way into the slot. The module stops when its front is about 0.25 inches (0.6 cm) outside the front of the chassis.
- d) Rotate the ejector lever all the way to the front of the chassis until it locks in place with a click. The module is fully seated on the midplane.
- e) Screw in the two captive screws to secure the module to the chassis. Tighten each of these screws to 8 in-lb (0.9 N·m) of torque.
- f) Verify that the Status (STS) LED blinks in amber color, turns to solid amber color, and later turns to green color, and the Active (ACT) LED is amber or green.

Installing and Removing a Blank Line Card

When a line card slot is not in use, fill the empty slot with a blank line card to allow the router to conform to electromagnetic interference (EMI) emissions requirements and to allow proper airflow across the line cards.

Figure 4: Blank Line Card (NC55-5500-LC-BLNK)

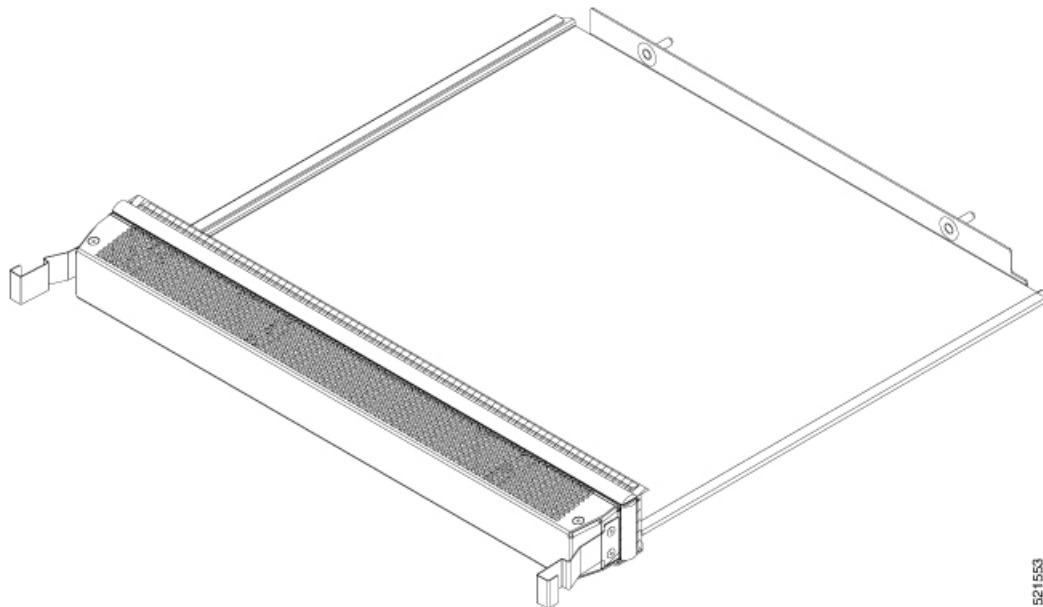

521553

Installing a Blank Line Card

This procedure shows how to insert a blank line card into a line card slot:

Procedure

- Step 1** Hold the front of the blank line card with one hand and place your other hand under it.
- Step 2** Align the back of the blank line card with the guides in the open line card slot and slide it all the way into the slot. The two latches on the sides of the blank line card should be locked onto the brackets on the side of the chassis.
- To prevent jamming the blank line card between the upper and the lower edges of the slot, make certain that you position it correctly, as shown in this illustration.

Figure 5: Inserting a Blank Line Card

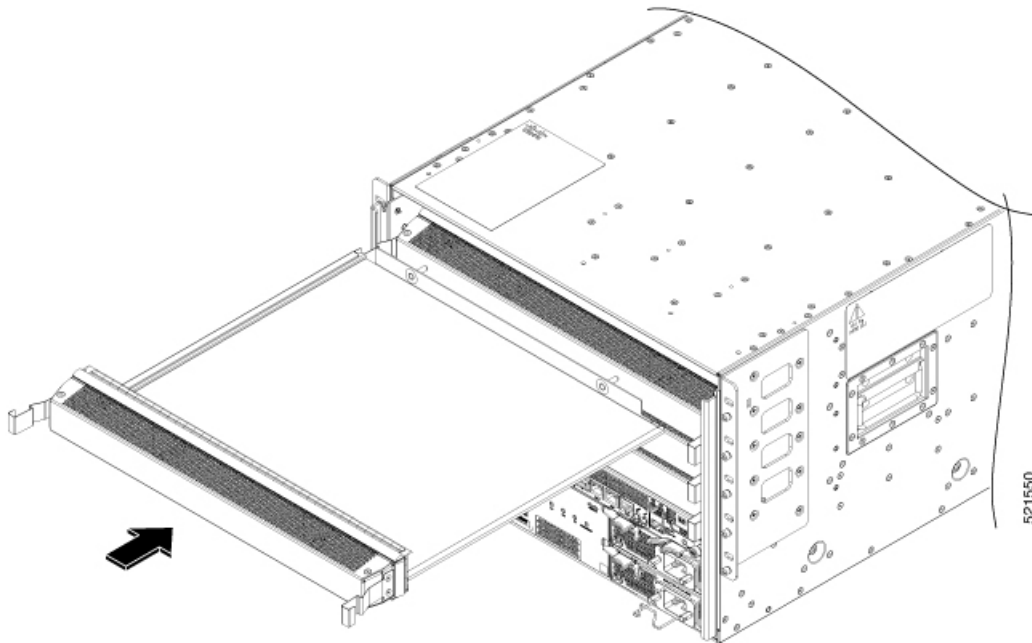

- Note** The latches are stiff and may require extra force to fully engage with the brackets on the sides of the chassis.

Removing a Blank Line Card

This procedure shows how to remove a blank line card from a line card slot:

Procedure

- Step 1** Press the two latches on the sides of a blank line card using your forefingers so that it is unlocked from the brackets on the side of the chassis. Gently pull it out a bit.

Figure 6: Hold the Latches on the sides

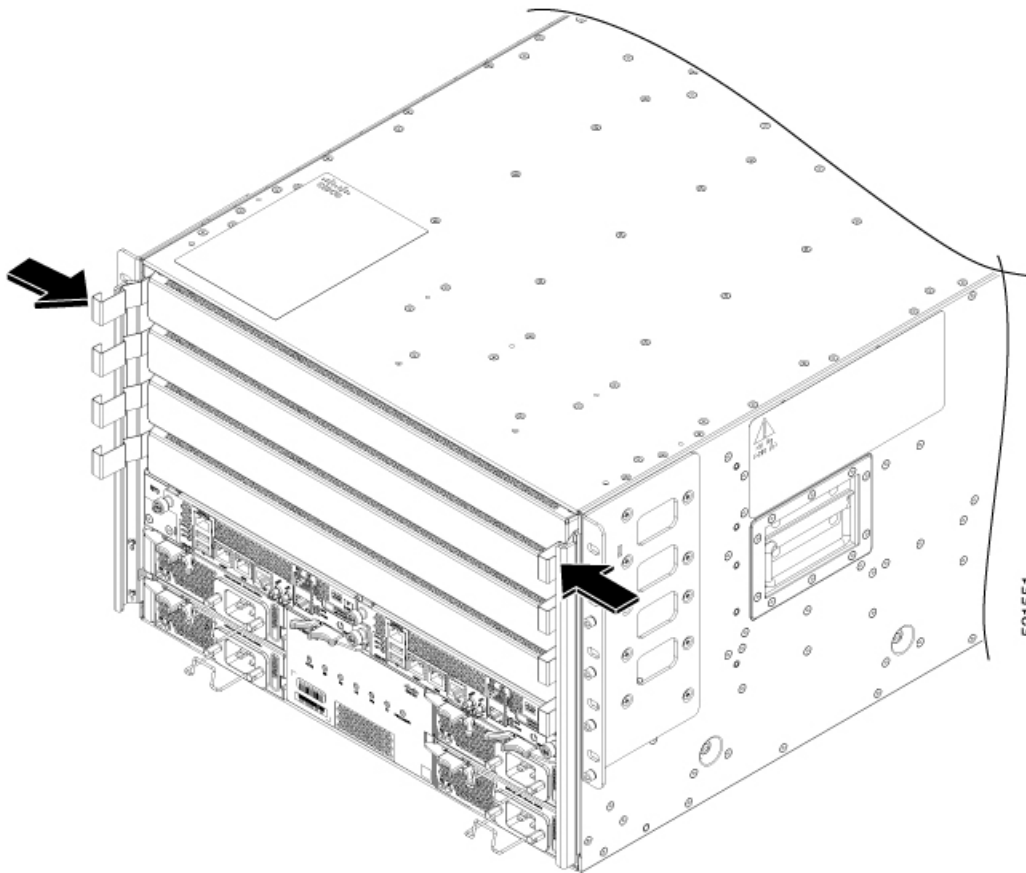

Step 2 Hold the blank line card using both hands, and pull it completely out of the chassis slot.

Figure 7: Removing the Blank Line Card

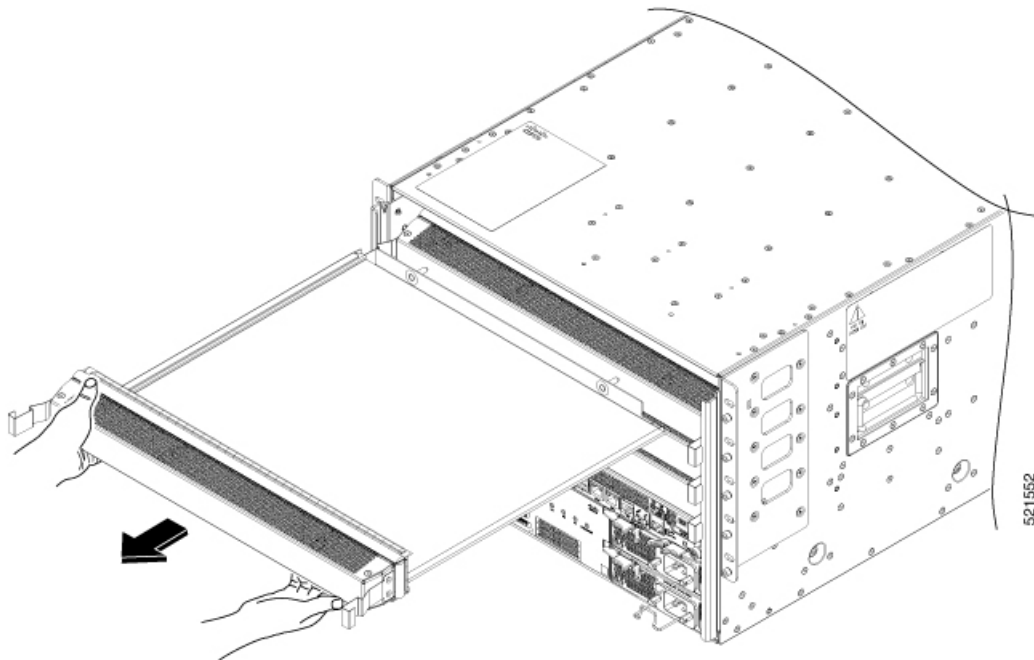

Note The latches are stiff and may require extra force to fully disengage from the brackets on the sides of the chassis.

Replace a Line Card

The router can operate with one or more line cards installed in the chassis. If there is at least one line card installed and operating in the chassis, you can replace another line card or install a new line card in an empty line card slot.



Warning **Statement 1029**—Blank Faceplates and Cover Panels

Blank faceplates and cover panels serve three important functions: they prevent exposure to hazardous voltages and currents inside the chassis; they contain electromagnetic interference (EMI) that might disrupt other equipment; and they direct the flow of cooling air through the chassis. Do not operate the system unless all cards, faceplates, front covers, and rear covers are in place.



Warning **Statement 1051**—Laser Radiation

Invisible laser radiation may be emitted from disconnected fibers or connectors. Do not stare into beams or view directly with optical instruments.

Watch [Replace a Line Card \(Video\)](#)

Procedure

Step 1 Open the packaging for the new line card and inspect the module for damage.

If the module is damaged, contact the Technical Assistance Center (TAC).

Step 2 If you are replacing a module that is currently in the chassis, remove the existing module from the chassis by following these steps:

- a) Disconnect and label each of the interface cables from the module.
- b) Run the **hw-module location <loc> shutdown** command in admin EXEC mode, which gracefully shuts down the line card. Alternatively, you can execute the **hw-module shut location <loc>** command in XR config mode.
- c) Verify that the line card Status (STS) LED for the slot that you specified turns off. Also, you can verify that the card is in powered off state running the **show platform** command to verify the status of the card to be POWERED_OFF.
- d) Rotate each of the two ejector levers away from the center of the chassis (see the following figure).

Figure 8: Remove a Line Card from the Chassis

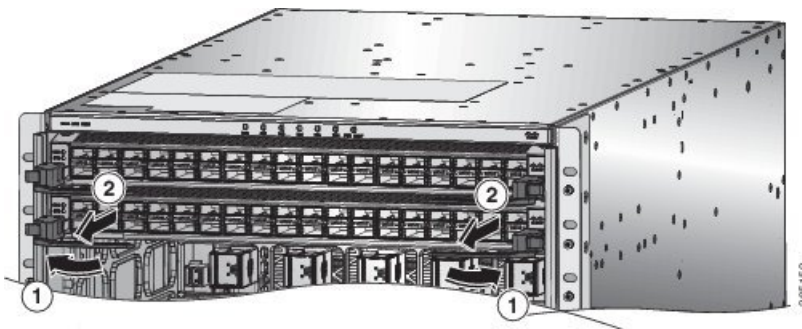

1	Rotate the ejector handle on each end of the module away from the center of the chassis until they no longer hold onto the mounting bracket.	2	Pull each ejector handle to remove the module part way from the chassis.
---	--	---	--

The levers unlock themselves from the brackets on the side of the chassis.

- e) Use the levers to pull the module a couple of inches (about 5 cm) from the chassis.
- f) Use one hand to hold the front of the module, place your other hand under the module to support its weight, pull it out of the chassis, and set it on an antistatic surface or inside an antistatic bag.

Step 3 To install the new module, follow these steps:

- a) Rotate the end of each of the two ejector levers away from the center of the chassis.
- b) Hold the front of the module with one hand and place your other hand under the module to support its weight.
- c) Align the back of the module to the guides in the open line card slot and slide the module all the way into the slot (see the following figure).

The module stops when its front is about 0.25 inches (0.6 cm) outside the front of the chassis. The two levers move part way to the front of the chassis.

Figure 9: Insert a Line Card into the Chassis

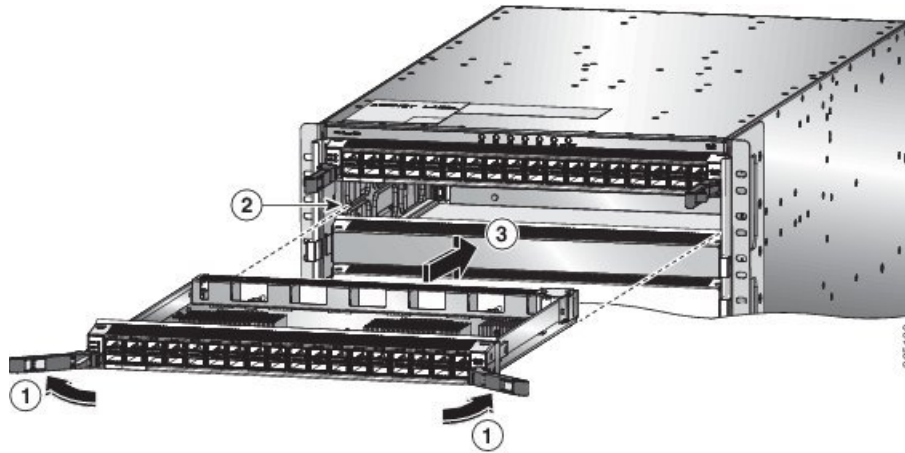

1	Rotate the ejector handle on each end of the module away from the center of the chassis.	3	Slide the module all the way into the slot.
2	Align the bottom of the back of the module with tracks on either side of the slot.		

- d) Rotate the ends of the two levers toward the center of the chassis.
 When the levers point straight out from the chassis, their other ends should be locked onto the brackets on the side of the chassis.
 As you rotate the levers, the front of the module moves all the way to the front of the chassis and the module fully seats on the midplane of the chassis.
- e) Attach each interface cable to the appropriate port on the line card. Use the label on each cable to determine which port each cable attaches to.
- f) Login to the System admin config mode. Power on the card gracefully using the **no hw-module shutdown location <loc>** command. Alternatively, you can execute the **hw-module unshut location <loc>** or **no hw-module shut location <loc>** command in XR config mode.
- g) Verify that the line card LEDs turn on and appear as follows:
 - The Status (STS) LED blinks in amber color, then turns to solid amber color, and later turns to green color.
 - For each connected port, the port LED turns on and becomes green or amber.

Installing and Removing Modular Port Adapters

The following sections describe how to install or remove MPA:

Handling Modular Port Adapters

Each modular port adapter (MPA) circuit board is mounted to a metal carrier and is sensitive to electrostatic discharge (ESD) damage.



Caution Always handle the MPA by the carrier edges and handle; never touch the MPA components or connector pins (See the figure below).

When a bay is not in use, a blank MPA Slot Filler must fill the empty bay to allow the router or switch to conform to electromagnetic interference (EMI) emissions requirements and to allow proper airflow across the installed modules. If you plan to install a MPA in a bay that is not in use, you must first remove the blank.

Figure 10: Handling a Modular Port Adapter

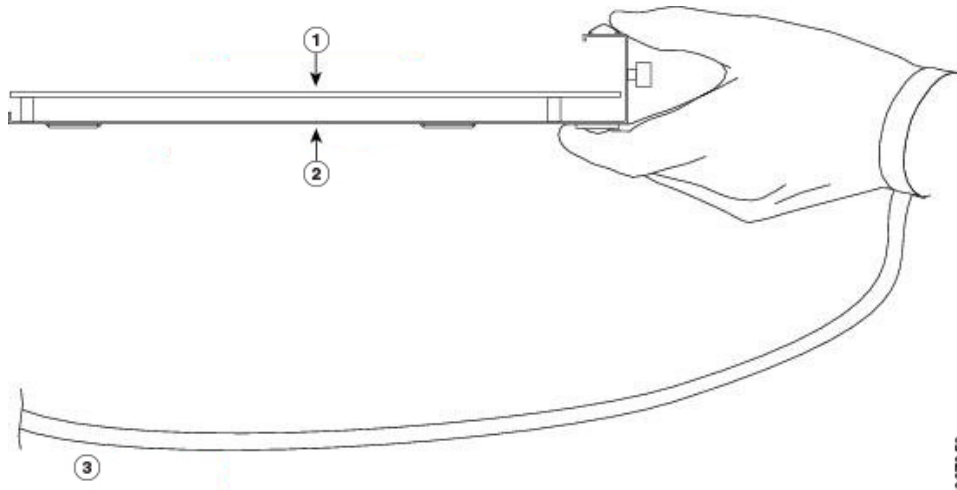

1	Printed Circuit Board	2	Metal Carrier
3	Grounding Strap		

Online Insertion and Removal



Caution Cisco IOS XR Software 6.6.1 and later releases support online insertion and removal (OIR) of Cisco NCS 5500 series modular port adapters (MPAs).

Cisco NCS 5500 series modular port adapters (MPAs) support online insertion and removal (OIR). Modular port adapters (MPAs) can be inserted or removed independently from the modular line card (MLC). OIR of a MLC with installed modular port adapters (MPAs) is also supported.

Limitation:

- During online insertion and removal of MPA on the Cisco ASR 9000 Series router, the field-programmable gate array (FPGA) turns off and the physical interface (PHY) is unavailable to inhibit the clock. As a result, you will observe a SyncE jump of 80 - 120 ns on downstream nodes.

Modular port adapters (MPAs) support the following types of OIR:

- Soft OIR

Soft OIR uses the IOS XR **hw-module subslot** *rack/slot/subslot* **reload**, **hw-module subslot** *rack/slot/subslot* **shutdown**, and **no hw-module subslot** *rack/slot/subslot* **shutdown** commands to complete online insertion and removal.

- Managed OIR

A managed online insertion and removal of Modular port adapters (MPAs) is comprised of the following steps:

- Shut down the MPA with the **hw-module subslot** *rack/slot/subslot* **shutdown** command.
- Confirm that the LEDs have gone from green to off.
- Execute the **do show platform** command to verify that the MPA to be removed is in the disabled state.
- Physically remove the MPA to be replaced.
- Physically insert the replacement MPA. After inserting the MPA in the slot, tighten the MPA screw located on the right side within 10 seconds. Ensure that you first tighten the right screw and then the left.



Note Tighten the captive screws on the MPA within 10 seconds. Otherwise, the MPA shuts down and moves to **Disabled** state. To recover the MPA, tighten both the captive screws and then execute the **hw-module subslot** *rack/slot/subslot* **reload** command.

- Return the MPA to the up state with the **no hw-module subslot** *rack/slot/subslot* **shutdown** command.

- Hard OIR

You can perform the OIR in a running system, by performing the following steps, without executing any commands:

- Loosen the right ejector screw.
- Loosen the left ejector screw.
- Remove and replace the MPA.

Modular Port Adapter Installation and Removal

This section provides step-by-step instructions for removing and installing a modular port adapter (MPA) in a NC55-MOD-A-S and NC55-MOD-A-SE-S modular line card (MLC).



Note After you remove the MPA from the slot, wait for 60 seconds before you reinsert the MPA.



Note After you unscrew both ejector screws, wait for 15 seconds before removing MPA from the slot.

To remove and install a MPA, do the following:

1. To insert the MPA, locate the guide rails inside the MLC that hold the MPA in place. They are at the bottom left and bottom right of the MPA slot and are recessed about an inch.
2. Carefully slide the MPA all the way in the MLC until the MPA is firmly seated in the MPA interface connector. When fully seated, the MPA might be slightly behind the faceplate.



Note The MPA will slide easily into the slot if it is properly aligned on the tracks. If the MPA does not slide easily, do NOT force it. Remove the MPA and reposition it, paying close attention to engaging it on the tracks. Push the MPA inside the slot until you hear a click. Continue to push the MPA further until you hear a second click. The MPA is fully seated only after the second click is heard.

3. After the MPA is properly seated, use a number 2 Phillips screwdriver to tighten the captive screws on the MPA. Ensure that you first tighten the right screw and then the left.



Note Tighten the captive screws on the MPA within 10 seconds. Otherwise, the MPA shuts down and moves to **Disabled** state. To recover the MPA, tighten both the captive screws and then execute the **hw-module subslot rack/slot/subslot reload** command.



Note Avoid over torquing the MPA captive screws when installing the MPA. Tighten the captive screws on the MPA to a torque of 6 +/-0.5 inch-pound.

4. To remove the MPA from the MLC, use a number 2 Phillips screwdriver to loosen the captive screws on the MPA. Ensure that you first loosen the right screw and then the left.
5. Grasp the MPA and pull the MPA from the MLC. (You have already disconnected the cables from the MPA.)

Replace a Fan Tray

You can remove a fan tray to either replace it with another fan tray or to replace a fabric cards located behind it.

The router uses three fan trays but it can operate with two fan trays while you replace one or remove one to replace one of the fabric cards behind the fan tray. When you remove one fan tray, the other fan trays speed up their fans to maintain the designed airflow.



Note If you cannot replace a fan tray within three minutes, we recommend that you leave it in the chassis until you are ready to replace it.



Note If you remove more than one fan tray at a time during operations, the router allows up to two minutes of operations before shutting down unless you replace extra missing fan trays within that time. If the router senses an over temperature condition when multiple fan trays are removed, the shutdown can occur in less than two minutes.



Note In the case of a single fan tray failure, for the Cisco NCS 5500 series modular routers to continue operations, the maximum permissible temperature is 30°C, at an altitude of 1800 meters.

To replace a fan tray, you must perform the following functions:

1. Remove the fan tray. For more information, see [Remove Fan Tray, on page 15](#).
2. If you need to replace a fabric card behind the removed fan tray, see [Replace Fabric Card, on page 18](#).
3. Install a fan tray as explained in [Install Fan Tray, on page 16](#).

Watch [Replace a Fan Tray \(Video\)](#)

Remove Fan Tray

Remove only one fan tray at a time during router operations. If you remove more than one fan tray at a time, the router will shut down within two minutes unless you replace the extra fan trays that you removed within that time.

Procedure

Step 1 Unscrew the four captive screws on the front of the fan tray until each screw is free of the chassis (see the following figure).

Figure 11: Remove Fan Tray from the Chassis

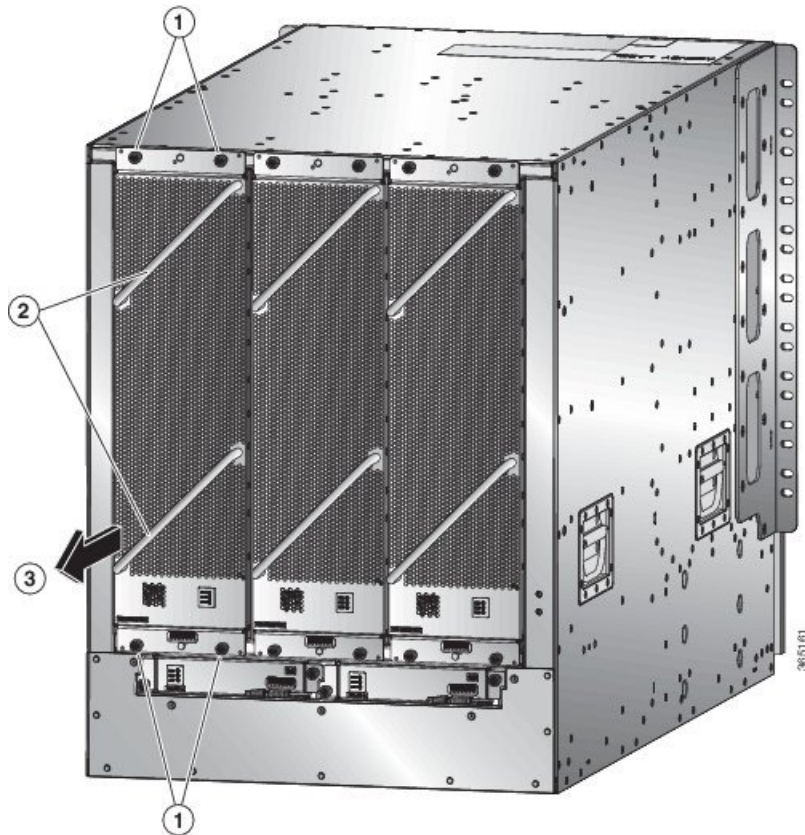

1	Unscrew four captive screws (two at the top of the module and two at the bottom of the module).	3	Pull on the fan tray to slide it out of the chassis. Set the fan tray on an antistatic surface.
2	Hold the two fan tray handles with your two hands.		

Step 2 Hold both handles on the front of the fan tray with both of your hands and pull the fan tray out of the slot.

Step 3 Set the fan tray on antistatic material or inside an antistatic bag.

Install Fan Tray

Before you begin

- Fan tray slot is open in the chassis.
- Fan tray is available for installation.
- If you are replacing a fabric card behind the open fan tray slot, ensure that the fabric card replacement operation is completed.

Procedure

Step 1 Use both of your hands to hold the two handles on the front of the fan tray that you are installing.

Figure 12: Install Fan Tray in Chassis

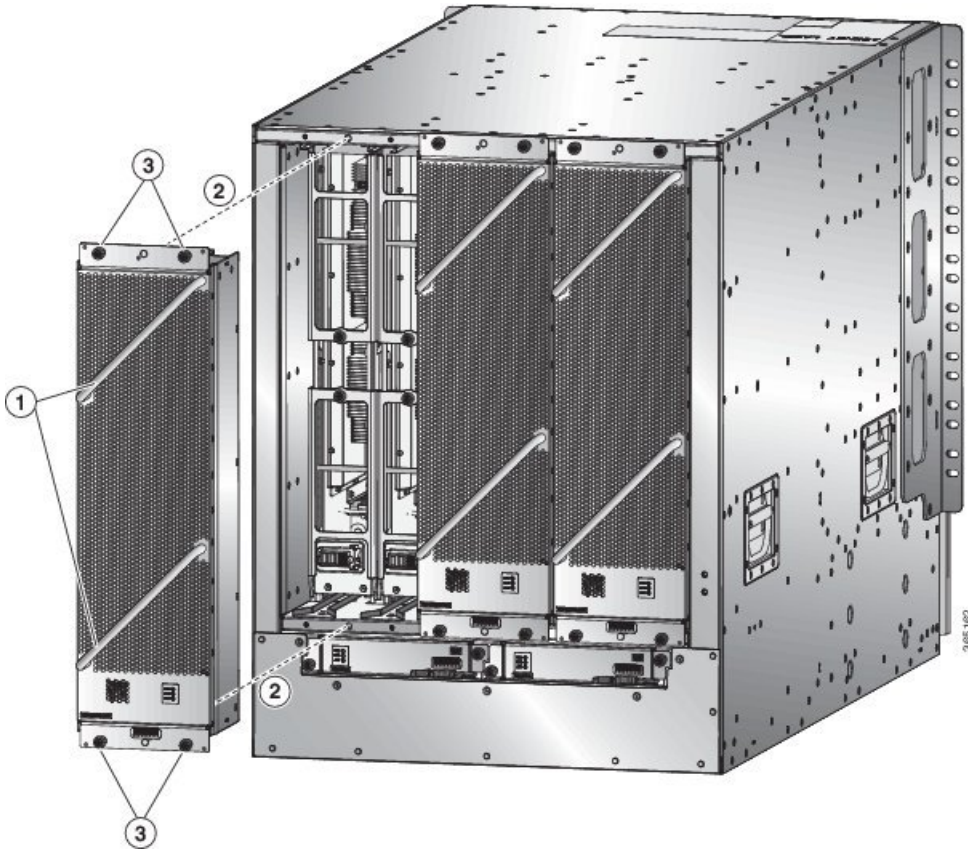

1	Hold the two fan tray handles with your two hands.	3	Screw in four captive screws and tighten each screw to 8 in-lb (0.9 N·m) of torque.
2	Position the back of the fan tray to the open fan tray slot. The pins on the top and bottom of the fan tray should align to holes in the chassis and the two sets of rails on the top of the fan tray should align to two sets of tracks on the top of the open slot. Slide the fan tray all the way into the slot.		

Step 2 Position the fan tray with its rear (the side with the electrical connectors) at the opening for the fan tray slot in the chassis.

Step 3 Align the two tracks on the top of the fan tray with the two sets of rails at the top of the open fan tray slot in the chassis.

Step 4 Slide the fan tray all the way into the slot until the front of the fan tray touches the chassis.

Make sure that the four captive screws on the front of the fan tray align with the four screw holes in the chassis.

Step 5 Screw in the four captive screws to secure the fan tray to the chassis. Tighten the screws to 8 in-lb (0.9 N·m) of torque.

Step 6 Verify that the fan tray STATUS LED turns on and becomes green.

Replace Fabric Card

The router uses either three or six fabric cards but you can replace a fabric card while others are operating. To replace a fabric card, you must do each of the following:

- Shutdown the fabric card being replaced.
- Remove the fan tray covering the fabric card in the chassis.
- Remove the fabric card.
- Install the new fabric card.
- Reinstall the fan tray over the fabric card.
- Activate the fabric card.

To maintain the designed airflow while you remove the fan tray, the fans in the other fan trays increase their speed. During operations, it is recommended that you remove only one fan tray at a time and reinstall that fan tray within three minutes to avoid the possibility of having the router overheat and shut down. If you remove more than one fan tray at a time, the router will shut down if you do not reinstall the extra missing fan trays within two minutes (the shutdown can occur earlier if the router overheats).



Note If the router does not have all of the fabric slots filled, fill them as indicated in the following table and insert blank filler plates in the open slots. If you do not fill the recommended slots with fabric cards, some of the fans will not power up.

Table 1: Fabric Card Slots to Fill

Number of Fabric cards	Slots to be Filled
1 (Not allowed)	N.A.
2 (Not recommended)	N.A.
3 (Minimum recommended number)	Labeled as FC1, FC3, and FC5
4	Labeled as FC1, FC2, FC3, and FC5
5	Labeled as FC0, FC1, FC2, FC3, and FC5, or Labeled as FC1, FC2, FC3, FC4, and FC5
6 (Fully populated)	Labeled as FC0, FC1, FC2, FC3, FC4, and FC5



Note NCS 5508 and NCS 5516 chassis requires fully populated second generation fabric cards for fans to perform at 100%.

To replace a fabric card, you must perform these operations, which are explained in the topics that follow:

1. Remove the fan tray that covers the fabric card that you are replacing.
2. Shut down and remove the fabric card.
3. Install the new fabric card.
4. Install the fan tray over the new fabric card.

Watch [Replace Fabric Card \(Video\)](#)

Removing a Fabric Card

Before you begin

- You must wear an electrostatic discharge (ESD) wrist strap or other ESD protective device while handling modules.
- Prepare an antistatic surface or packing materials for each module that you remove from the chassis.



Note After executing the command in sysadmin config mode, **commit** the command for the configuration to take effect.

Procedure

-
- Step 1** If you are replacing a fabric card, open the packaging for the new module and inspect it for damage. If the module is damaged, alert the Technical Assistance Center (TAC) and stop this replacement process until you have an undamaged module to install.
- Step 2** To prevent loss of packets during operations, shut down the fabric card as follows:
- a) Shut the fabric control plane using the **controller fabric plane <plane-id> shutdown** command in the sysadmin config mode.

There are six planes and the value of the *<plane-id>* is between 0 to 5.

When you are replacing the card, shutdown the corresponding fabric plane of the card. For example, when you are replacing the card in slot 0 (0/FC0), shut down fabric plane 0.
 - b) Run the **hw-module shutdown location <loc>** command in the sysadmin config mode. Alternatively, you can execute the **hw-module shut location <loc>** command in XR config mode.

- c) Verify that the fabric (FAB/FC) LED for the slot that you specified turns off, on the fan tray. Also, you can verify that the card is in powered off state running the **show platform** command in the sysadmin mode to verify the status of the card to be POWERED_OFF.

Step 3 Remove the fan tray that covers the fabric card by following these steps:

- a) Unscrew the four captive screws on the front of the fan tray (one on each corner of the front of the fan tray) until each screw is free of the chassis (see Callout 1 in the following figure).

Figure 13: Removing a Fan Tray from the Chassis

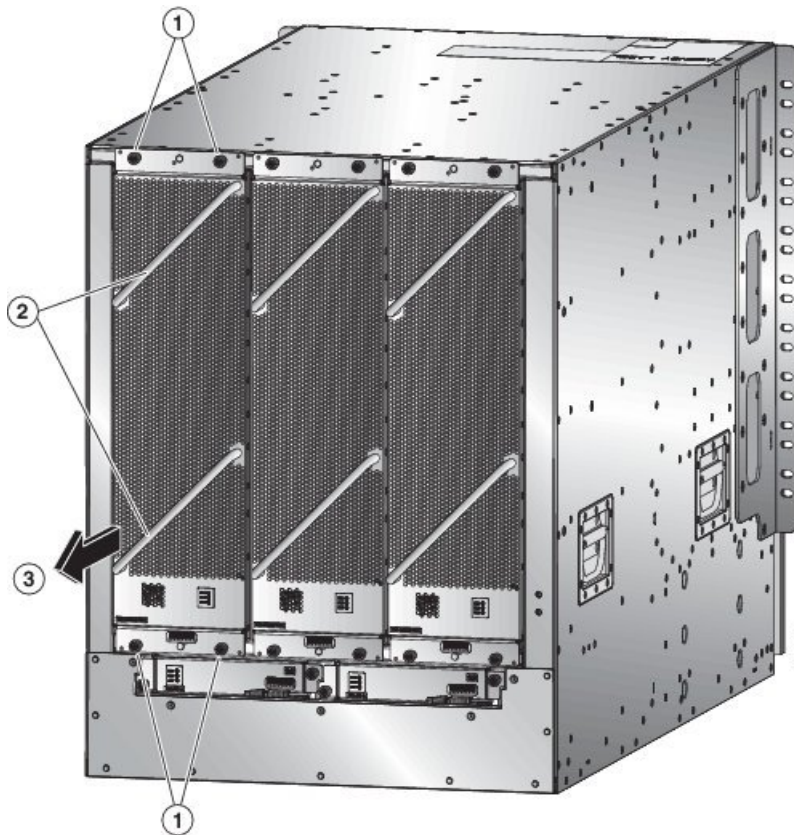

1	Unscrew four captive screws (two at the top of the module and two at the bottom of the module).	3	Pull on the fan tray to slide it out of the chassis. Set the fan tray on an antistatic surface.
2	Hold the two fan tray handles with your two hands.		

- b) Hold both handles on the front of the fan tray with both of your hands and pull the fan tray out of the slot.
 c) Set the fan tray on antistatic material or inside an antistatic bag.

Step 4 Remove the fabric card that you are replacing by following these steps:

- a) Unscrew the screw on the center of each of the two handles on the fabric card (see Callout 1 in the following figure).

Figure 14: Unlocking a Fabric Card from its Slot in the Chassis

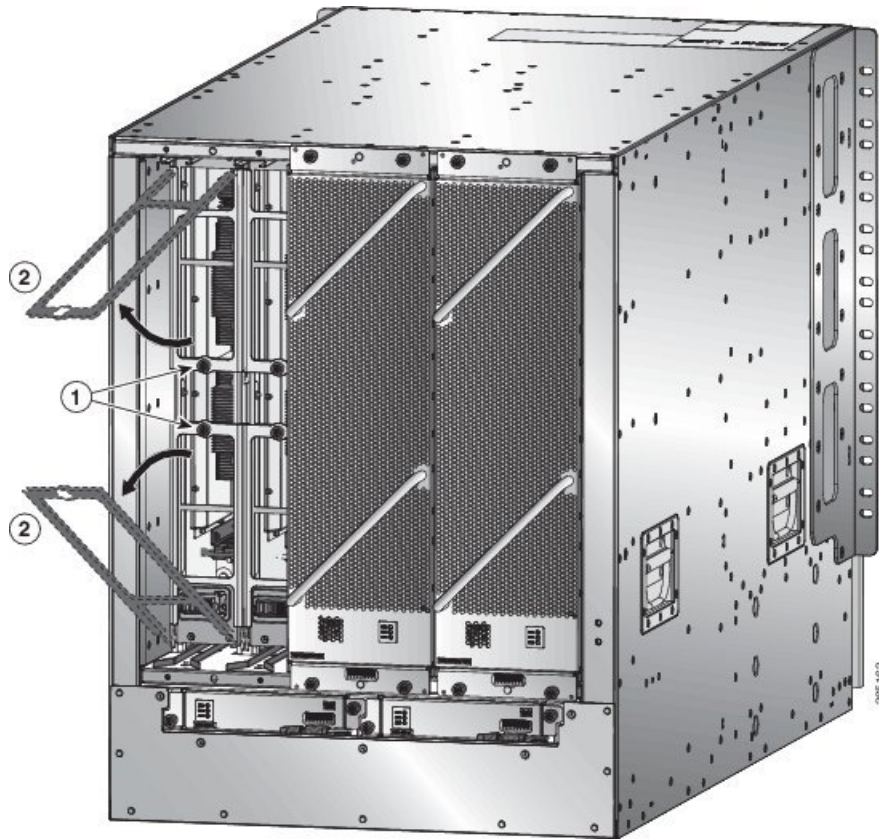

1	Unscrew two captive screws (one on each ejector handle).	2	Rotate both ejector handles away from the front of the fabric card.
---	--	---	---

- b) Rotate the two handles at least 30 degrees so that the other end of each handle no longer holds the module in the slot (see Callout 2 in the previous figure).
- c) With each of the two handles in your two hands, pull the module a couple of inches (about 5 cm) out of the slot (see the following figure).

Figure 15: Removing a Fabric Card from the Chassis

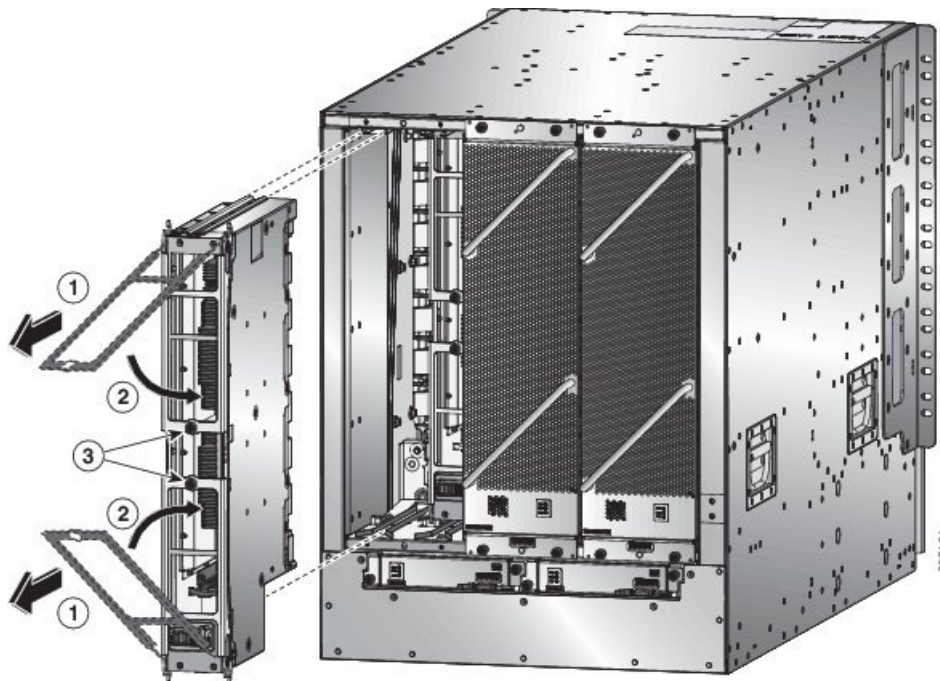

1	Pull on both handles to partially remove the fabric card from the chassis	3	Screw in the two captive screws (one on each handle) to the module. Tighten each of these screws to 8 in-lb (0.9 N·m) of torque.
2	Rotate both ejector handles to the front of the module.		

- d) Rotate both handles back to the front of the module until they click in place. Fasten each handle to the module using the captive screw on the back of the handle. Tighten the screw to 8 in-lb (0.9 N·m) of torque (see callouts 2 and 3 in the previous figure).
- e) Place one hand under the fabric card to support its weight, place your other hand on the front of the module, and slide the module out of the slot.
- f) Rotate the module 90 degrees and lay it flat on an antistatic surface or in an antistatic bag.

- Step 5** Replace the card, and login to the System admin config mode. Power on the card gracefully using the **no hw-module shutdown location <loc>** command. Alternatively, you can execute the **hw-module unshut location <loc>** or **no hw-module shut location <loc>** command in XR config mode.
- Step 6** Verify that the card shows as operational in XR VM and System Admin VM using the **show platform** command in the sysadmin mode. From the System admin config mode, enable the plane using the **no controller fabric plane <plane-id> shutdown** command.
- Step 7** Verify if the plane displays “UP UP” using the **show controllers fabric plane all** command in the sysadmin mode.

Restrictions for using XR plane hw-module configuration

These are the restrictions for using XR plane hw-module configuration:

- The XR plane hw-module config is supported only in Single-SDR system (SOST). In Multi-SDR, the configuration gets rejected with an appropriate error message.
- In XR plane, the show running-config shows only the unshut configuration if it is explicitly configured. To remove the unshut configuration execute the no hw-module unshut location <loc> command in XR config mode.
- When the hw-module is configured as unshut in XR, the admin exec hw-module operation like reload, shutdown, offline and so on are allowed. Similarly, when the hw-module is shut down through admin exec command, unshut config from XR will not bring the card out of shut down.
- The XR plane hw-module config overwrites the sysadmin hw-module config for the same location, if any.
- Although the XR side hw-module config are synced to sysadmin, the show running-config in sysadmin shows only the shut config. The unshut config will not explicitly shown in sysadmin, as the unshut is treated as no hw-module shut in sysadmin.
- The sysadmin hw-module config is not synced to an XR plane, so the show running-config in XR does not show any hw-module config that are directly configured from sysadmin plane.
- When the XR plane is used for hw-module shut or hw-module unshut config, the sysadmin plane should not be used to modify the same hw-module config.
- When XR RP VM is deleted, the shutdown config replicated to the sysadmin remains. Even if the XR VM is created again, the shutdown config presented earlier cannot be recovered again in the XR side.

Install a Fabric Card

Procedure

- Step 1** Place one hand on the front of the module and turn the module 90 degrees so that the electrical connectors are on the bottom.
- Step 2** Unscrew the two captive screws (one on each ejector handle) and rotate the ejector handles away from the chassis (see Callouts 1 and 2 in the following figure). Be sure that the locking posts on the top and bottom of the chassis (see Callout 3) rotate into the module so that the module can slide fully into the slot.

Figure 16: Installing a Fabric Card in a Chassis

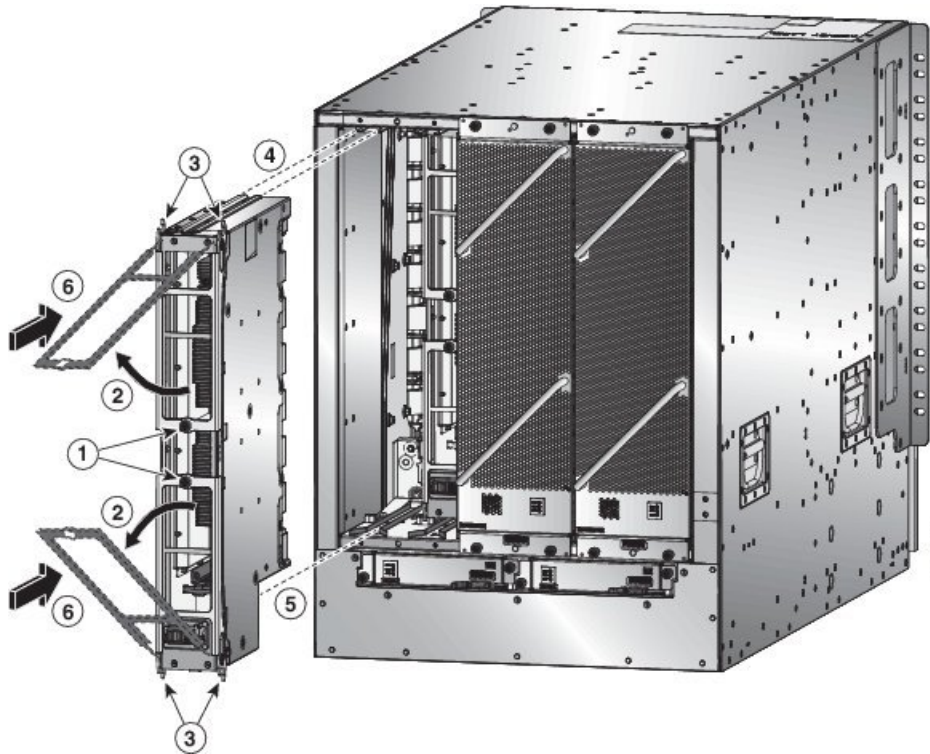

1	Unscrew two captive screws (one on each ejector handle).	4	Align the rails on the top of the module to the track on the top of the open slot.
2	Rotate both ejector handles away from the front of the module.	5	Align the bottom of the module so that it slides into the tracks on the bottom of the open slot.
3	Be sure that the locking posts fully rotate down into the module	6	Slide the module all the way into the slot.

- Step 3** Fit the guide rails on the top of the module into the track on the top of the slot and make sure that the guide bar on the bottom of the module goes into the module guide at the bottom of the slot.
- Step 4** Slide the module all the way into the slot.
- Step 5** Rotate both ejector levers to the front of the chassis and be sure that the module is locked to the top and bottom of the slot.
- Step 6** Screw in the captive screw on each of the two levers so that each lever is locked in place on the module. Tighten each screw to 8 in-lb (0.9 N·m) of torque.
- Step 7** Reinstall the fan module over the replaced fabric card by following these steps:
- Use both of your hands to hold the two handles on the front of the fan tray that you are installing.

Figure 17: Install Fan Tray in Chassis

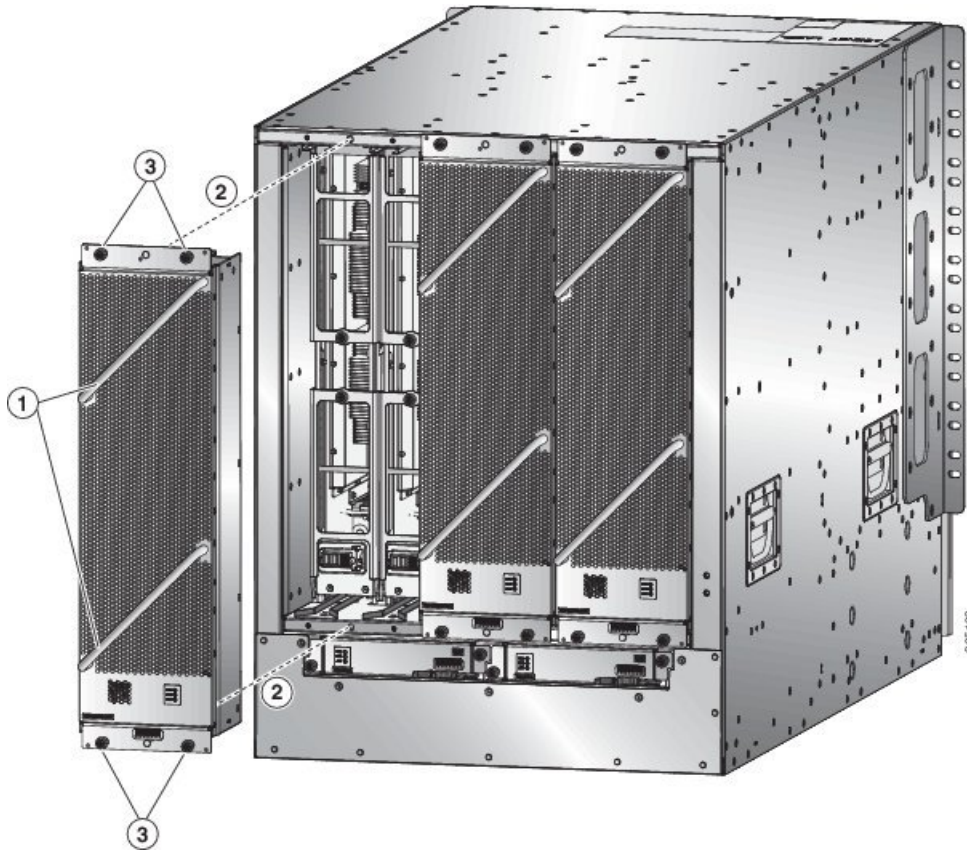

1	Hold the two fan tray handles with your two hands.	3	Screw in four captive screws and tighten each screw to 8 in-lb (0.9 N·m) of torque.
2	Position the back of the fan tray to the open fan tray slot. The pins on the top and bottom of the fan tray should align to holes in the chassis and the two sets of rails on the top of the fan tray should align to two sets of tracks on the top of the open slot. Slide the fan tray all the way into the slot.		

- b) Position the fan tray with its rear (the side with the electrical connectors) at the opening for the fan tray slot in the chassis.
- c) Align the two tracks on the top of the fan tray with the two sets of rails at the top of the open fan tray slot in the chassis.
- d) Slide the fan tray all the way into the slot until the front of the fan tray touches the chassis.
Make sure that the four captive screws on the front of the fan tray align with the four screw holes in the chassis.
- e) Screw in the four captive screws to secure the fan tray to the chassis. Tighten the screws to 8 in-lb (0.9 N·m) of torque.
- f) Verify that the fan tray and fabric card STATUS LEDs (on the fan tray) turn on and become green.

Replace Power Supplies

The number of power supplies that you install depends on the power requirements of the router and the power mode that you are using. To determine the power requirements of the router, see the [Weight, Quantity and Power Consumption](#) section.

If you are using only one power source for the combined mode or $n+1$ redundancy mode, you can install the power supplies in any of the power supply slots on the chassis. If you are using two power sources for the $n+n$ redundancy mode, you must connect the power supplies in slots 1 through 4 to one power source and the power supplies in slots 5 through 8 to the other power source. With $n+n$ redundancy mode, divide the power supplies evenly between the first half of the slots and the last half of the slots so that the amount of redundant power for the router equals the amount of available power for the router.



Note The NCS 5516 with the 3.15-kW HVAC/HVDC power supply supports $n+n$ line redundancy mode. The 3-kW AC or DC power supplies can be used for $n+1$ redundancy mode.

You can install or replace the power supplies in the router so long as all of the power supplies are the same type:

- Cisco NCS 5500 3-kW Standard AC Power Supply
- Cisco NCS 5500 3-kW Standard DC Power Supply
- Cisco NCS 5500 3.15-kW HVAC/HVDC Power Supply

Replace AC Power Supply

Before you begin

- The AC power source must be installed within reach of the power cables.
- The AC power source must meet the power specifications required by the router.
- There are one or two AC power sources available. If using $n+n$ redundancy, there must be two power sources available. Otherwise, only one power source is required.

Procedure

- Step 1** Open the packaging for the new 3-kW standard AC power supply and inspect the module for damage. If the module is damaged, contact the Technical Assistance Center (TAC).
- Step 2** If you are installing the module in an empty slot, remove the blank filler plate that is already in that slot by unscrewing its captive screw and pulling it out of the slot.
- If you are using the combined power mode or $n+1$ redundancy, you can use any power supply slot in the chassis.
 - If you are using $n+n$ redundancy mode, you must be sure that you are inserting the power supply in a slot used for the desired power supply:

- **NCS 5504:** The power supplies in slots 1 and 2 must be connected to one power source and the power supplies in slots 3 and 4 must be connected to the other power source
- **NCS 5508:** The power supplies in slots 1 through 4 must be connected to one power source and the power supplies in slots 5 through 8 must be connected to the other power source

Go to Step 4.

Step 3

If you are replacing a power supply that is currently in the chassis, remove the existing module from the chassis by following these steps:

- Disconnect the power cable from the power supply and verify that the output and input LEDs turn off.
- Slide the middle of the ejector lever down to the end of the lever and rotate the lever up so that its other end no longer holds onto the chassis (see the following figure).

The power supply unlocks from the chassis and moves out slightly.

Figure 18: Remove Power Supply from the Chassis

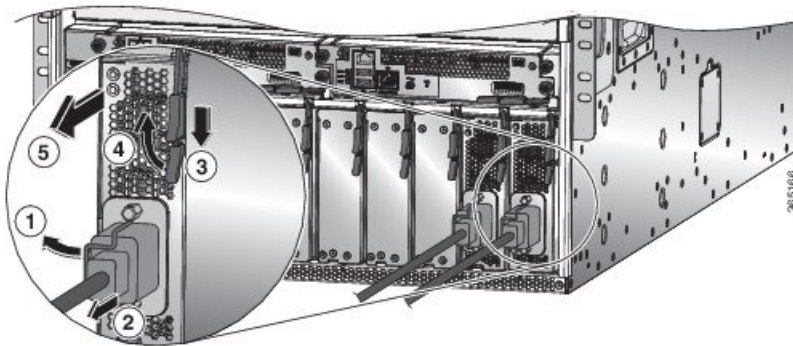

1	Rotate the cable retention clip away from the power cable plug.	4	Rotate the ejector lever away from the module.
2	Pull the power cable plug out of the receptacle.	5	Pull on the ejector lever to slide the power supply partially (2 inches [5 cm]) out of the chassis. Hold the front of the power supply and pull it all the way out of the chassis.
3	Slide and hold the middle handle on the ejector lever toward the end of the lever.		

- Pull on the lever to move the power supply about 2 inches (5 cm) out of the slot.

Caution Do not use the ejector lever to fully remove the power supply from the chassis. The ejector lever cannot support the full weight of the power supply. Using the ejector lever to fully remove the power supply from the chassis can damage the power supply and the ejector lever.

- Place one hand on the front of the power supply and your other hand under the power supply to support its weight.
- Pull the module out of the slot and place it on an antistatic surface or inside an antistatic bag.

Step 4

To install the new power supply, follow these steps:

- a) Ensure that the power supply is not connected to an AC power source. If it is connected to a power source, remove the power cable from the power supply and wait at least five seconds before doing the next step.
- b) Hold the front of the module with one hand and place your other hand under the module to support its weight.
- c) Rotate the power supply 90 degrees so that the power receptacle is positioned on the lower front side and so that the back of the power supply is oriented to slide into the open power supply slot.
- d) Slide the guide bracket that is located on the top of the power supply into the track at the top of the power supply slot. Slide the power supply all the way into the slot.

The front of the power supply will be about 0.25 inches (0.6 cm) outside the chassis.

- e) Slide the handle on the middle of the power supply ejector handle about 0.25 inches (0.6 cm) and rotate the lever away from the front of the power supply while pushing the power supply all the way into the chassis (see the following figure).

Figure 19: Installing a Power Supply in a Chassis

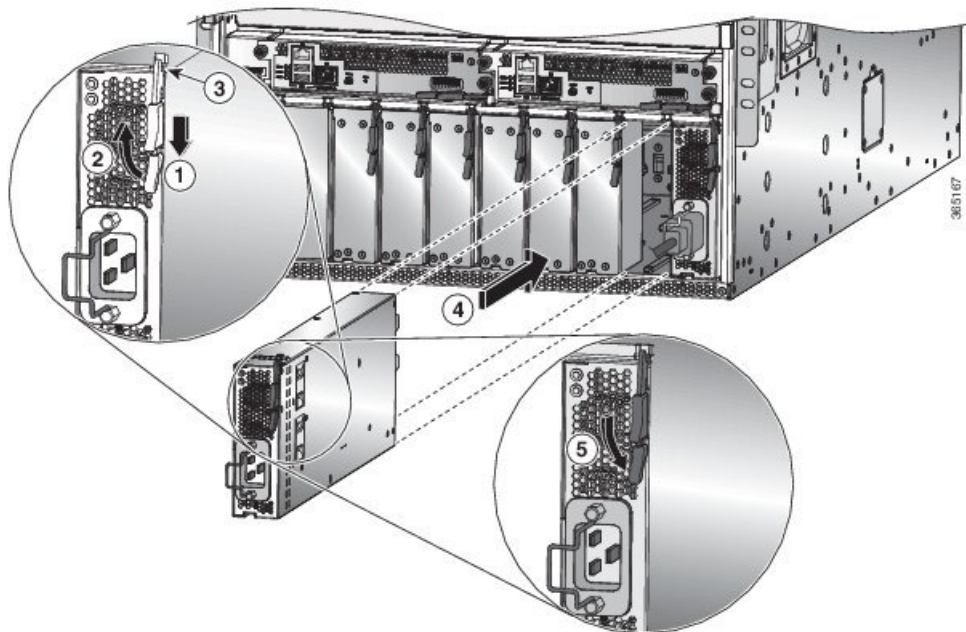

1	Slide and hold the middle handle on the ejector lever toward the end of the lever.	4	Slide the rear end of the power supply all the way into the slot and press the ejector lever toward the front of the power supply to lock it in the slot.
2	Rotate the ejector lever away from the module.	5	Rotate the lever to the front of the power supply and verify that the power supply is locked into its slot by trying to pull it out.
3	Make sure that the locking knob has rotated into the power supply and cannot prevent the power supply from sliding all the way into the chassis slot.		

- f) Rotate the ejector lever toward the front of the power supply and be sure that the other end of the lever locks into the chassis.

The lever should click when you rotate it all the way to the front of the power supply. Be sure that the power supply is fully inserted into the slot (the front of the power supply should be even with the surface of the chassis) and securely in place.

- g) Attach the power cable to the power receptacle on the power supply and rotate the power cable holder onto the plug on the cable.
- h) Make sure that the other end of the power cable is attached to the AC power source in one of the following ways:
 - If you are using the combined power mode or the $n+1$ redundancy mode, you must connect the power cable to the same power source as used by the other power supplies in the same router.
 - If you are using the $n+n$ redundancy mode, you must connect the power cable to the same power source as used by the other power supplies in the same set of power supply slots in the chassis.
 - **NCS 5504:** The power cables for slots 1 and 2 must be connected to one power source and the power cables in slots 3 and 4 must be connected to another power source.
 - **NCS 5508:** The power cables for slots 1 through 4 must be connected to one power source and the power cables in slots 5 through 8 must be connected to another power source.
 - **NCS 5516:** The power cables for slots 1 through 5 must be connected to one power source and the power cables in slots 6 through 10 must be connected to another power source.
- i) Verify that the OK LED turns on and eventually becomes green.

Replace DC Power Supply

Before you begin

- The power source must be installed within reach of the power cables.
- The power source must meet the power specifications required by the switch.
- There are one or two power sources available. If using $n+n$ redundancy, there must be two power sources available. Otherwise, only one power source is required.
- Prepare an antistatic surface or antistatic bag for the power supply that you are removing.

Procedure

- Step 1** Open the packaging for the new DC power supply and inspect the module for damage.
If the module is damaged, contact the Technical Assistance Center (TAC).
- Step 2** If you are installing the module in an empty slot, remove the blank filler plate that is already in that slot by unscrewing its captive screw and pulling it out of the slot. Go to Step 4.
- Step 3** If you are replacing a power supply that is currently in the chassis, remove the existing module from the chassis by following these steps:
 - a) Turn off the power to the power supply that you are replacing as follows:

1. Shut off the power supply by setting its power switch to 0.
2. If the power supply is connected to a DC circuit, shut off the circuit at the circuit breaker.
3. Verify that the OK LED has turned off (indicates that there is no power going to the power supply).

Note The FAULT LED might be on and amber colored to indicate that the power source connection has been broken.

b) Disconnect the power cables from the power supply as follows:

1. Remove the three screws on the safety cover for the terminal box located on the front of the power supply and pull the cover off the terminal box as shown in the following figure.

Note The terminal box has four slots for four power terminals (ordered as negative [-], positive [+], positive [+], and negative [-]). Each terminal has two nuts that you use to fasten a power cable to the terminal.

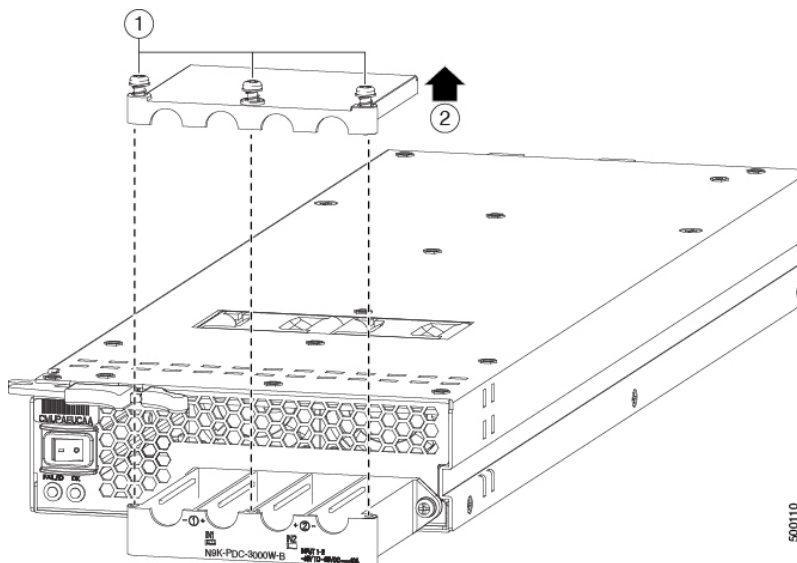

1	Remove 3 screws from the safety cover.	2	Remove the cover.
---	--	---	-------------------

2. Unscrew the two nuts holding each of the four cables to the terminal box, remove the cables, and replace the nuts on the two posts in each of the slots.
3. Replace the safety cover on the terminal box and secure it in place with three screws.

c) Remove the power supply from the chassis as follows:

1. Slide the middle of the ejector lever down to the end of the lever and rotate the lever away from the chassis.
The power supply unlocks from the chassis and moves out slightly.
2. Pull on the lever to move the power supply about 2 inches (5 cm) out of the slot.
3. Place one hand on the front of the power supply and your other hand under the power supply to support its weight.
4. Pull the module out of the slot and place it on an antistatic surface or inside an antistatic bag.

Step 4

To install the new power supply, follow these steps:

- a) If you are using a DC power source, ensure that the circuit is turned off at the circuit breaker.
- b) Hold the front of the power supply module with one hand and place your other hand under the module to support its weight.
- c) Slide the guide bracket into the track of the power supply slot. Slide the power supply into the slot until the front of the module stops about 0.25 inches (0.6 cm) in front of the module.
- d) Slide the handle on the middle of the power supply release lever towards the end of the module and rotate the lever away from the front of the power supply while pushing the power supply all the way into the chassis (see the following figure).

Figure 20: Install DC Power Supply

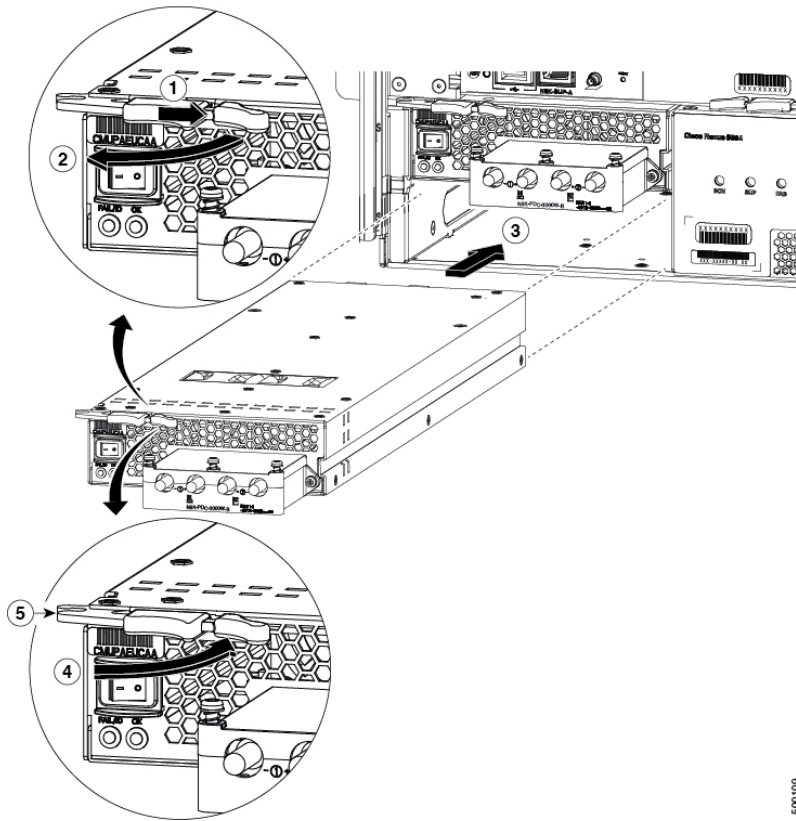

1	Slide and hold the middle handle next to the outer handle.	4	Rotate the lever towards the front of the module.
2	Fully rotate the release lever away from the front of the module.	5	Make sure that the other end of the lever grabs the chassis to push the module onto the connectors in
3	Slide the power supply into the open power supply slot in the chassis until it stops with the front of the module about 0.25 inches (0.6 cm) in front of the chassis.		

- e) Rotate the ejector lever toward the front of the power supply and be sure that the other end of the lever locks into the chassis.

The lever should click when you rotate it all the way to the front of the power supply. Be sure that the power supply is fully inserted into the slot (the front of the power supply should be even with the surface of the chassis) and securely in place.

Step 5 Connect the power cables to the power supply as follows:

- a) Verify that the circuit breakers for both input lines from the DC power source are turned off.
- b) Use a torque screwdriver to unscrew three screws on the cover for the terminal box that is located on the front of the power supply and lift off the cover as shown in the following figure.

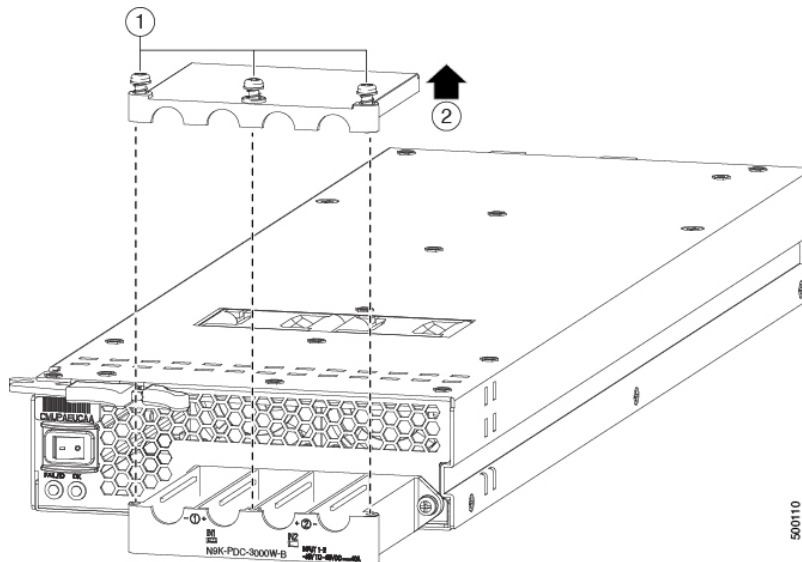

1	Remove 3 screws from the safety cover.	2	Remove the cover.
---	--	---	-------------------

- c) Remove the two nuts from each terminal post in each slot of the terminal box.
- d) Place each of the lugs for the two positive cables on the terminal posts for the positive slots (two middle slots) of the terminal box and fasten each lug using two nuts tightened to 40 in-lb (4.5 N·m) of torque.
- e) Place each of the lugs for the two negative cables on the terminal posts for the negative slots (two side slots) of the terminal box and fasten each lug using two nuts tightened to 40 in-lb (4.5 N·m) of torque.
- f) Replace the safety cover on the terminal box and fasten it in place using its three screws.

Step 6 Power up the power supply as follows:

- a) Turn on the power source circuit breaker for both input lines.

Verify that the Input 1 (IN1) and Input 2 (IN2) LEDs light up on the power supply.

- b) Turn the power switch on the power supply to ON (labeled 1 on the power supply).

The LEDs should flash and then the OK LED should turn on (green) in addition to the Input LEDs.

Replace HVAC/HCDC Power Supply

Before you begin

- The power source must be installed within reach of the power cables.
- The power source must meet the power specifications required by the switch.
- There are one or two power sources available. If using $n+n$ redundancy, there must be two power sources available. Otherwise, only one power source is required.

Procedure

- Step 1** Open the packaging for the new HVAC/HVDC power supply and inspect the module for damage.
If the module is damaged, contact the Technical Assistance Center (TAC).
- Step 2** If you are installing the module in an empty slot, remove the blank filler plate that is already in that slot by unscrewing its captive screw and pulling it out of the slot.
Go to Step 4.
- Step 3** If you are replacing a power supply that is currently in the chassis, remove the existing module from the chassis by following these steps:

Figure 21: Removing an HVAC/HVDC Power Supply

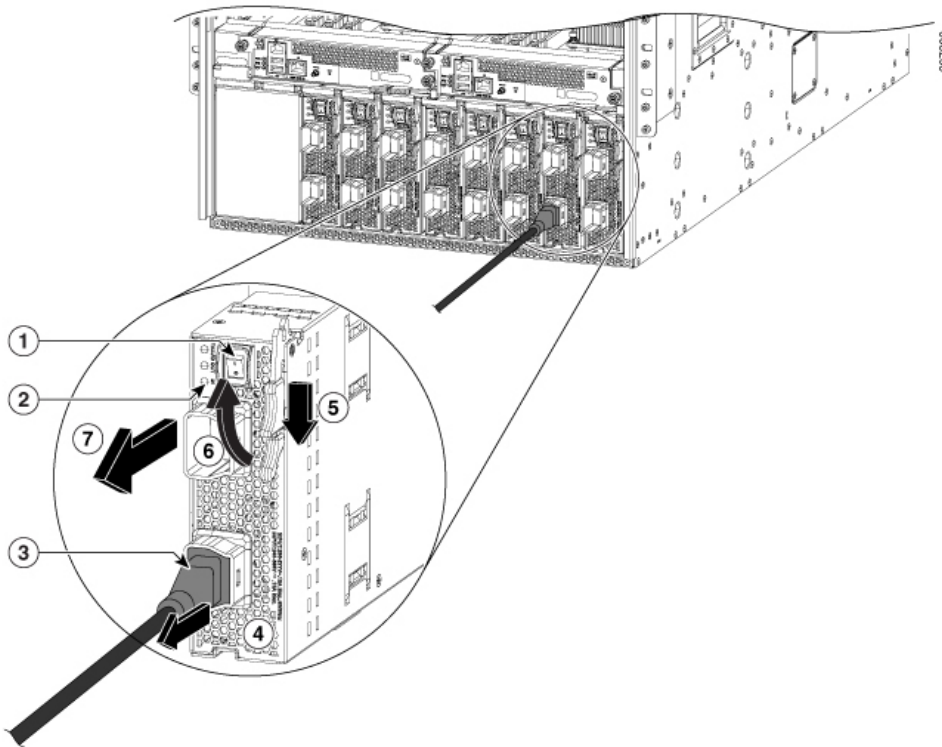

1	Turn off the power supply (and circuit breaker for a DC circuit)	5	Pull the middle lever handle toward the end of the lever.
2	Verify that the OK LED turns off. Note The FAULT LED might be on and amber colored to indicate that the power source connection has been broken.	6	Rotate the release lever away from the power supply.
3	Press and hold the release button on the plug.	7	Pull the module out of the slot and place it on an antistat surface or inside an antistatic bag.
4	Pull the power cable plug out of the power supply receptacle.		

Step 4 To install the new power supply, follow these steps:

Note If you are using a DC power source, ensure that the circuit is turned off at the circuit breaker.

Figure 22: Installing an HVAC/HVDC Power Supply

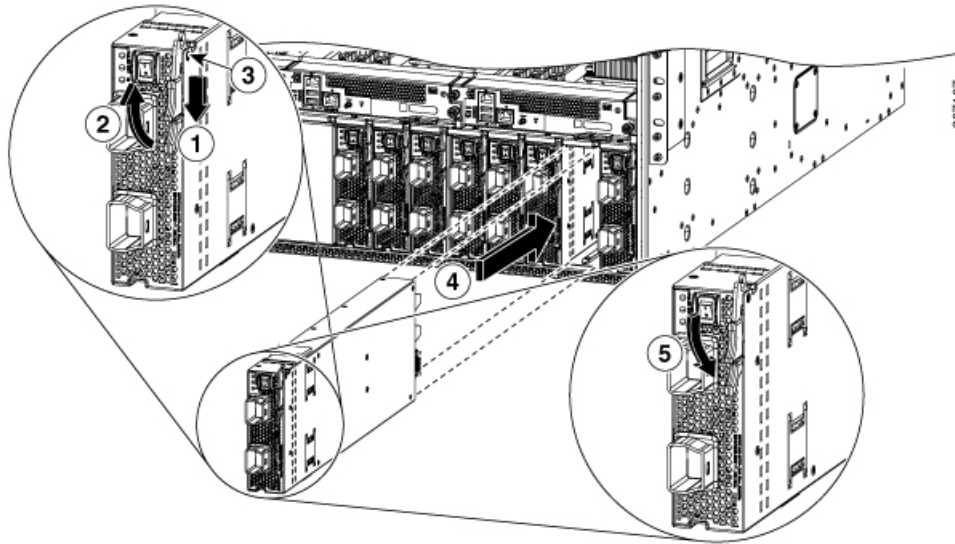

1	Slide and hold the middle handle on the ejector lever toward the end of the lever.	4	Slide the rear end of the power supply all the way into the slot and press the ejector lever toward the front of the power supply to lock it in the slot.
2	Rotate the ejector lever away from the module.	5	Rotate the lever to the front of the power supply and that the power supply is locked into its slot by trying to pull it out.
3	Make sure that the locking knob has rotated into the power supply and cannot prevent the power supply from sliding all the way into the chassis slot.		

Step 5 Attach the power cable to the power receptacle on the power supply.

Note If you are using $n+n$ redundancy mode, you must connect one set of the power supply inputs to one power grid and the other set of the power supply inputs to another power grid (for example, connect grid A to the receptacles closest to the power switch on the power supplies, and connect grid B to the receptacles furthest from the power switch on the power supplies).

Step 6 Make sure that the other end of the power cable is attached to the power source.

Step 7 If you connected the power supply to a DC power source do the following, turn on the circuit breaker for the DC power source.

Step 8 Turn on the power supply by setting the power switch to on (1).

Step 9 Verify that the OK LED turns on and eventually becomes green.

