



# Configuring SIP Message Timer and Response Features

This chapter describes how to configure Session Initiation Protocol (SIP) message components, session timers, and responses. It describes the following features:

## History for the Internal Cause Code Consistency Between SIP and H.323 Feature

Release	Modification
12.2(11)T	These features were introduced.

## History for the SIP - Configurable PSTN Cause Code Mapping Feature

Release	Modification
12.2(2)XB	This feature was introduced.
12.2(2)XB2	This feature was implemented on an additional platform.
12.2(8)T	This feature was integrated into this release.
12.2(11)T	This feature was implemented on additional platforms.

## History for the SIP Accept-Language Header Support Feature

Release	Modification
12.3(1)	The SIP Accept-Language Header Support feature was introduced.

## History for the SIP Enhanced 180 Provisional Response Handling Feature

Release	Modification
12.2(13)T	The features were introduced.

**History for the SIP Extensions for Caller Identity and Privacy Feature**

Release	Modification
12.2(13)T	The features were introduced.

**History for the SIP INVITE Request with Malformed Via Header Feature**

Release	Modification
12.2(2)XB	This feature was introduced.
12.2(8)T	This feature was integrated into this release.
12.2(11)T	Support was added for additional platforms.

**History for the SIP Session Timer Support Feature**

Release	Modification
12.2(11)T	These features were introduced.
12.4(9)T	This feature was updated to support RFC 4028.

**History for the SIP: Cisco IOS Gateway Reason Header and Buffered Calling Name Completion Feature**

Release	Modification
12.3(8)T	This feature was introduced.

**History for the SIP: SIP Header/URL Support and SUBSCRIBE/NOTIFY for External Triggers Feature**

Release	Modification
12.3(4)T	This feature was introduced.

**History for the SIP Stack Portability Feature**

Release	Modification
12.4(1)T	This feature was introduced.

**History for the SIP: Domain Name Support in SIP Headers Feature**

Release	Modification
12.4(2)T	This feature was introduced.

**History for the SIP Gateway Support for SDP Session Information and Permit Hostname CLI Feature**

Release	Modification
12.4(9)T	This feature was introduced.

**History for the Outbound Proxy Support for the SIP Gateway**

Release	Modification
12.4(15)T	This feature was introduced.
12.4(20)T	Support was added for disabling outbound proxy support for SIP on a per dial peer basis

**History for the SIP Support for PAI**

Release	Modification
12.4(15)T	This feature was introduced.

**History for the SIP History-info Header Support Feature**

Release	Modification
12.4(22)T	This feature was introduced.
15.1(2)T	Support was added to enhance the privacy by enabling Cisco UBE to summarize the content of the history-info header in the outgoing message without letting out any internal topology information.

**Feature History for Support for SIP 181 Call is Being Forwarded Message**

Release	Modification
15.0(1)XA	Support for SIP 181 Call is Being Forwarded message was added to Cisco IOS SIP TDM gateways and Cisco UBEs.
15.1(1)T	This feature was integrated into this release.

**Feature History for Support for Expires Timer Reset on Receiving or Sending SIP 183 Message**

Release	Modification
15.0(1)XA	Support for resetting the Expires timer upon receipt of SIP 183 messages on Cisco Unified Communications Manager Express (Cisco Unified CME), a Cisco IOS voice gateway, or a Cisco UBE.
15.1(1)T	This feature was integrated into this release.

### Feature History for Support for Stripping off Progress Indication from Incoming ISDN Messages on SIP and H.323 TDM Gateways

Release	Modification
15.0(1)XA	Support for stripping off progress indication from incoming ISDN messages on Cisco IOS SIP and H.323 TDM gateways and on Cisco UBEs.
15.1(1)T	This feature was integrated into this release.

### History for the SIP: Via Header Support Feature

Release	Modification
15.1(1)T	This feature was introduced.

### History for the SIP: SIP Trunk Registration feature

Release	Modification
15.1(2)T	This feature was introduced.

- [Finding Feature Information, on page 4](#)
- [Prerequisites for SIP Message Timer and Response Features, on page 4](#)
- [Restrictions for SIP Message Timer and Response Features, on page 5](#)
- [Information About SIP Message Components Session Timers and Response Features, on page 7](#)
- [How to Configure SIP Message Timer and Response Features, on page 76](#)
- [Configuration Examples for SIP Message Timer and Response Features, on page 143](#)
- [Additional References, on page 173](#)

## Finding Feature Information

Your software release may not support all the features documented in this module. For the latest caveats and feature information, see [Bug Search Tool](#) and the release notes for your platform and software release. To find information about the features documented in this module, and to see a list of the releases in which each feature is supported, see the feature information table at the end of this module.

Use Cisco Feature Navigator to find information about platform support and Cisco software image support. To access Cisco Feature Navigator, go to [www.cisco.com/go/cfn](http://www.cisco.com/go/cfn). An account on Cisco.com is not required.

## Prerequisites for SIP Message Timer and Response Features

### All SIP Message Components, Session Timers, and Responses Features

- Ensure that the gateway has voice functionality that is configurable for SIP.

- Establish a working IP network. Refer to the following Cisco IOS IP Configuration Guides by navigating to them from the Product Support page (<http://www.cisco.com/web/psa/products/index.html?c=268438303>) according to your Cisco IOS release):
  - *Cisco IOS IP Addressing Services Configuration Guide*
  - *Cisco IOS IP Mobility Configuration Guide*
  - *Cisco IOS IP Multicast Configuration Guide*
  - *Cisco IOS IP Routing Protocols Configuration Guide*
- Configure VoIP.
- Configure SIP voice functionality.

### **SIP: Cisco IOS Gateway Reason Header and Buffered Calling Name Completion Feature**

- For the reason header, do the following:
  - Configure the CLI reason-header override, in SIP user-agent (SIP UA) configuration mode, if you want the Reason header to take precedence over existing cause-code-mapping tables on the gateway receiving Reason header.
- For buffered calling name completion (such as buffer-invite timers), do the following:
  - Complete the prerequisites associated with the Support for the ISDN Calling Name Display feature in release 12.3(4)T (refer to the “Configuring SIP DTMF Features” chapter).
  - Configure a buffer invite timer value.
- Ensure that the incoming ISDN setup contains a name-to-follow indication as described in [Generic Requirements for ISDN Calling Name Identification Services for Primary Rate Interface \(PRI\) specification, GR-1367](#).

## **Restrictions for SIP Message Timer and Response Features**

### **All SIP Message Components, Session Timers, and Responses Features**

- Via handling for TCP is not implemented.

### **SIP Permit Hostname Command Features**

- The maximum length of a hostname is 30 characters; SIP INVITE message support will truncate any hostname over 30 characters.

### **SIP Accept-Language Header Support Feature**

- The Accept-Language header provided by the inbound SIP call leg is passed to the outbound call leg only if that call leg is SIP as well.

### **SIP Extensions for Caller Identity and Privacy Feature**

- This feature does not support the Anonymity header described in the Internet Engineering Task Force (IETF) specification, draft-ietf-privacy-.02.txt. The feature implements presentation level anonymity at

Layer 5, rather than at the IP address level. Since the SIP gateway assumes that all adjacent signaling devices are trusted, it is recommended that border SIP proxy servers enforce anonymity policies at administrative boundaries.

- The IETF specification, draft-ietf-privacy-.02.txt, for mapping of North American Numbering Plan Area (NANPA) defined Automatic Number Identification Information Indicators (ANI II) or Originating Line Information (OLI) digits, is still under development. The current implementation of Cisco IOS VoiceXML supports carrying the ANI II digits as digits, rather than as a string representation of the numbering plan-tagged ANI II digits.

### **SIP INVITE Request with Malformed Via Header Feature**

- Distributed Call Signaling (DCS) headers and extensions are not supported.

### **SIP Session Timer Support Feature**

- This feature enables the SIP Portable stack and IOS gateway to comply with IETF RFC 4028 specification for SIP session timer.
- Cisco SIP gateways cannot initiate the use of SIP session timers but do fully support session timers if another user agent requests it.
- The Min-SE value can be set only by using the **min-se** command described in this document. It cannot be set using the CISCO-SIP-UA-MIB.

### **SIP: SIP Header/URL Support and SUBSCRIBE/NOTIFY for External Triggers Feature**

- For outbound calls, an application is allowed to pass any extended or nonstandard header except for the following:
  - Call-ID
  - Supported
  - Require
  - Min-SE
  - Session-Expires
  - Max-Forwards
  - CSeq
  - The “Tag” parameter within From and To headers (From and To headers themselves are allowed)

All other headers may be overwritten by the application to create the header lines in the SIP INVITE message.

- SUBSCRIBE and NOTIFY methods are supported for Tool Command Language (Tcl) applications only.

### **SIP Gateway Support for SDP Session Information Feature**

- The maximum length of a received session information line is 1000 characters; SIP gateway support truncates any session information line over 1000 characters.

### SIP: SIP Support for PAI

- Privacy for REGISTER messages is not supported. When a gateway registers with another endpoint, the gateway assumes this endpoint is within the trusted domain, therefore privacy regarding this transaction is unnecessary.

### SIP History-info Header Support Feature

- History-info header support is provided on Cisco IOS SIP time-division multiplexing (TDM) gateways and SIP-SIP Cisco Unified Border Elements (Cisco UBEs) only.
- Cisco IOS SIP gateways cannot use the information in the history-info header to make routing decisions.

## Information About SIP Message Components Session Timers and Response Features

### Internal Cause Code Consistency Between SIP and H.323

The Internal Cause Code Consistency Between SIP and H.323 feature establishes a standard set of categories for internal causes of voice call failures. Before this feature, the cause code that was passed when an internal failure occurred was not standardized or based on any defined rules. The nonstandardization led to confusing or incorrect cause code information, and possibly contributed to billing errors.

This feature establishes a standard set of categories for internal causes of voice call failures. Internal cause-code consistency enables more efficient and effective operation of combined SIP and H.323 networks, which reduces operational expenses and improves service availability.



---

**Note** RFC 2543-bis-04 enhancements obsolete the SIP cause codes 303 *Redirection: See Other* and 411 *Client Error: Length required*. For information on RFC 2543-bis-04 enhancements, refer to the “Achieving SIP RFC Compliance” chapter.

---

H.323 and SIP standard cause codes that are now generated accurately reflect the nature of each internal failure. This capability makes the H.323 and SIP call control protocols consistent with cause codes that are generated for common problems. Also, for each internal failure, an ITU-T Q.850 release cause code is also assigned and the table below maps the new standard categories with the Q.850 release cause code and description that is assigned to each category.

Table 1: H.323 and SIP Standard Category and Q.850 Cause Code Mapping

Standard Category	Standard Category Description	Q.850 Cause Code	Q.850 Release Cause Description
Socket Failure	<p>Typical scenarios:</p> <ul style="list-style-type: none"> <li>• Transmission Control Protocol (TCP) socket connection failure.</li> <li>• Problem sending an H.323 SETUP.</li> <li>• Problem sending a SIP INVITE.</li> <li>• Send or receive error occurs on connected socket.</li> </ul>	27	<p>CC_CAUSE_DESTINATION_OUT_OF_ORDER</p> <p>The destination indicated by the user cannot be reached because the destination's interface is not functioning correctly.</p> <p>The signaling message was unable to be delivered to the remote party.</p>
Destination Address Resolution Failure	<p>Typical scenarios:</p> <ul style="list-style-type: none"> <li>• Domain Name System (DNS) resolution failure.</li> <li>• Invalid session target in configuration.</li> </ul>	3	<p>CC_CAUSE_NO_ROUTE</p> <p>The called party cannot be reached because the network that the call has been routed through does not serve the desired destination.</p>
Call Setup Timeout Failure	<p>Typical scenarios:</p> <ul style="list-style-type: none"> <li>• No H.323 call proceeding.</li> <li>• No H.323 alerting or connect message received from the terminating gateway.</li> <li>• Invite expires timer reached maximum number of retries allowed.</li> </ul>	102	<p>CC_CAUSE_RECOVERY_ON_TIMER_EXPIRY</p> <p>A procedure has been initiated by the expiry of a timer in association with error handling procedures.</p>
Internal Resource Allocation Failure	<p>Typical scenarios:</p> <ul style="list-style-type: none"> <li>• Out of memory.</li> <li>• Internal access to the TCP socket becomes unavailable.</li> </ul>	47	<p>CC_CAUSE_NO_RESOURCE</p> <p>A "resource unavailable" event has occurred.</p>
Invalid Message Received Error	<p>Typical scenarios:</p> <ul style="list-style-type: none"> <li>• An invalid message was received.</li> </ul>	95	<p>CC_CAUSE_INVALID_MESSAGE</p> <p>An invalid message event has occurred.</p>



Standard Category	Standard Category Description	Q.850 Cause Code	Q.850 Release Cause Description
Mandatory IE Missing Error	Typical scenarios: <ul style="list-style-type: none"> <li>Mandatory Contact field missing in SIP message.</li> <li>Session Description Protocol (SDP) body is missing.</li> </ul>	96	CC_CAUSE_MANDATORY_IE_MISSING The equipment sending this cause has received a message that is missing an information element (IE). This information element must be present in the message before the message can be processed.
Invalid IE Contents Error	Typical scenarios: <ul style="list-style-type: none"> <li>SIP Contact field is present, but format is bad.</li> </ul>	100	CC_CAUSE_INVALID_IE_CONTENTS The equipment sending this cause code has received an information element that it has implemented. However, the equipment sending this cause code has not implemented one or more of the specific fields.
Message in Invalid Call State	Typical scenarios: <ul style="list-style-type: none"> <li>An unexpected message was received that is incompatible with the call state.</li> </ul>	101	CC_CAUSE_MESSAGE_IN_INCOMP_CALL_STATE Indicates that a message has been received that is incompatible with the call state.
Internal Error	Typical scenarios: <ul style="list-style-type: none"> <li>Failed to send message to Public Switched Telephone Network (PSTN).</li> </ul>	127	CC_CAUSE_INTERWORKING There has been interworking with a network that does not provide causes for actions it takes. Precise cause cannot be ascertained.
QoS Error	Typical scenarios: <ul style="list-style-type: none"> <li>Quality of service (QoS) error.</li> </ul>	49	CC_CAUSE_QOS_UNAVAILABLE The requested QoS cannot be provided.
Media Negotiation Failure	Typical scenarios: <ul style="list-style-type: none"> <li>No codec match occurred.</li> <li>H.323 or H.245 problem leading to failure in media negotiation.</li> </ul>	65	CC_CAUSE_BEARER_CAPABILITY_NOT_IMPLEMENTED The equipment sending this cause does not support the bearer capability requested.

## SIP - Configurable PSTN Cause Code Mapping

For calls to be established between a SIP network and a PSTN network, the two networks must be able to interoperate. One aspect of their interoperation is the mapping of PSTN cause codes, which indicate reasons for PSTN call failure or completion, to SIP status codes or events. The opposite is also true: SIP status codes or events are mapped to PSTN cause codes. Event mapping tables found in this document show the standard or default mappings between SIP and PSTN.

However, you may want to customize the SIP user-agent software to override the default mappings between the SIP and PSTN networks. The SIP - Configurable PSTN Cause Code Mapping feature allows you to configure specific map settings between the PSTN and SIP networks. Thus, any SIP status code can be mapped to any PSTN cause code, or vice versa.

When set, these settings can be stored in the NVRAM and are restored automatically on bootup.

## Default Mappings

The table below lists PSTN cause codes and the corresponding SIP event mappings that are set by default. Any code other than the codes listed are mapped by default to *500 Internal server error*.

**Table 2: Default PSTN Cause Code to SIP Event Mappings**

PSTN Cause Code	Description	SIP Event
1	Unallocated number	404 Not found
2	No route to specified transit network	404 Not found
3	No route to destination	404 Not found
17	User busy	486 Busy here
18	No user response	480 Temporarily unavailable
19	No answer from the user	
20	Subscriber absent	
21	Call rejected	403 Forbidden
22	Number changed	410 Gone
26	Non-selected user clearing	404 Not found
27	Destination out of order	404 Not found
28	Address incomplete	484 Address incomplete
29	Facility rejected	501 Not implemented
31	Normal, unspecified	404 Not found
34	No circuit available	503 Service unavailable
38	Network out of order	503 Service unavailable
41	Temporary failure	503 Service unavailable
42	Switching equipment congestion	503 Service unavailable
47	Resource unavailable	503 Service unavailable
55	Incoming class barred within Closed User Group (CUG)	403 Forbidden

PSTN Cause Code	Description	SIP Event
57	Bearer capability not authorized	403 Forbidden
58	Bearer capability not presently available	501 Not implemented
65	Bearer capability not implemented	501 Not implemented
79	Service or option not implemented	501 Not implemented
87	User not member of Closed User Group (CUG)	503 Service Unavailable
88	Incompatible destination	400 Bad request
95	Invalid message	400 Bad request
102	Recover on Expires timeout	408 Request timeout
111	Protocol error	400 Bad request
<b>Any code other than those listed above:</b>	<b>500 Internal server error</b>	

The table below lists the SIP events and the corresponding PSTN cause codes mappings that are set by default.

**Table 3: Default SIP Event to PSTN Cause Code Mapping**

SIP Event	PSTN Cause Code	Description
400 Bad request	127	Interworking, unspecified
401 Unauthorized	57	Bearer capability not authorized
402 Payment required	21	Call rejected
403 Forbidden	57	Bearer capability not authorized
404 Not found	1	Unallocated number
405 Method not allowed	127	Interworking, unspecified
406 Not acceptable		
407 Proxy authentication required	21	Call rejected
408 Request timeout	102	Recover on Expires timeout
409 Conflict	41	Temporary failure
410 Gone	1	Unallocated number
411 Length required	127	Interworking, unspecified
413 Request entity too long		
414 Request URI (URL) too long		

SIP Event	PSTN Cause Code	Description
415 Unsupported media type	79	Service or option not implemented
420 Bad extension	127	Interworking, unspecified
480 Temporarily unavailable	18	No user response
481 Call leg does not exist	127	Interworking, unspecified
482 Loop detected		
483 Too many hops		
484 Address incomplete	28	Address incomplete
485 Address ambiguous	1	Unallocated number
486 Busy here	17	User busy
487 Request cancelled	127	Interworking, unspecified
488 Not acceptable here	127	Interworking, unspecified
500 Internal server error	41	Temporary failure
501 Not implemented	79	Service or option not implemented
502 Bad gateway	38	Network out of order
503 Service unavailable	63	Service or option unavailable
504 Gateway timeout	102	Recover on Expires timeout
505 Version not implemented	127	Interworking, unspecified
580 Precondition Failed	47	Resource unavailable, unspecified
600 Busy everywhere	17	User busy
603 Decline	21	Call rejected
604 Does not exist anywhere	1	Unallocated number
606 Not acceptable	58	Bearer capability not presently available

## Benefits of SIP - Configurable PSTN Cause Code Mapping

The feature offers control and flexibility. By using CLI commands, you can easily customize the default or standard mappings that are currently available between PSTN and SIP networks. This allows for flexibility when setting up deployment sites.

## SIP Accept-Language Header Support

The SIP Accept-Language Header Support feature introduces support for the Accept-Language header in SIP INVITE messages and in OPTIONS responses. This feature enables you to configure up to nine languages to be carried in SIP messages and to indicate multiple language preferences of first choice, second choice, and so on.

Feature benefits include the following:

- Allows service providers to support language-based features
- Allows VXML applications providers to support language-based services

To configure Accept-Language header support, you need to understand the following concepts:

### Feature Design of SIP Accept-Language Header Support

Cisco implements this feature on SIP trunking gateways by supporting a new header, Accept-Language, as defined in the Internet Engineering Task Force (IETF) specification, draft-ietf-sip-rfc2543bis-09, SIP: Session Initiation Protocol. The Accept-Language header is used in SIP INVITES, which establish media sessions between user agents, and in SIP OPTIONS responses, which list user-agent capabilities. The header specifies language preferences for reason phrases, session descriptions, or status responses. A SIP proxy may also use the Accept-Language header to route to a human operator.

The Accept-Language header supports 139 languages, as specified in the International Organization for Standardization (ISO) specification, ISO 639: Codes for Representation of Names of Languages. The SIP Accept-Language Header Support feature allows you to configure up to nine languages to be carried in INVITE messages and OPTIONS responses. This feature also supports the qvalue (q=) parameter, which allows you to indicate multiple language preferences, that is, first choice, second choice, and so on.

### Sample INVITE Message

The following is a sample outgoing INVITE message for a gateway configured to support the Sindhi, Zulu, and Lingala languages.

```
11:38:42: Sent:
INVITE sip:36602@172.18.193.120:5060 SIP/2.0
Via: SIP/2.0/UDP 172.18.193.98:5060
From: <sip:172.18.193.98>;tag=27FB000-42E
To: <sip:36602@172.18.193.120>
Date: Mon, 01 Mar 1993 11:38:42 GMT
Call-ID: 23970D87-155011CC-8009E835-18264FDE@172.18.193.98
Supported: timer,100rel
Min-SE: 1800
Cisco-Guid: 0-0-0-0
User-Agent: Cisco-SIPGateway/IOS-12.x
Accept-Language: sd, zu, ln;q=0.123
Allow: INVITE, OPTIONS, BYE, CANCEL, ACK, PRACK, COMET, Refer, SUBSCRIBE, NOTIFY, INFO
CSeq: 101 INVITE
Max-Forwards: 10
Remote-Party-ID: <sip:172.18.193.98>;party=calling;screen=no;privacy=off
Timestamp: 730985922
Contact: <sip:172.18.193.98:5060>
Expires: 300
Allow-Events: telephone-event
Content-Type: application/sdp
Content-Length: 322
v=0
```

```

o=CiscoSystemsSIP-GW-UserAgent 5606 9265 IN IP4 172.18.193.98
s=SIP Call
c=IN IP4 172.18.193.98
t=0 0
m=audio 16434 RTP/AVP 18 100 101
c=IN IP4 172.18.193.98
a=rtpmap:18 G729/8000
a=fmtp:18 annexb=no
a=rtpmap:100 X-NSE/8000
a=fmtp:100 192-194
a=rtpmap:101 telephone-event/8000
a=fmtp:101 0-16
a=ptime:10

```

## Sample OPTIONS Response

The following is a sample OPTIONS response from a gateway configured to support the Yoruba, Sindhi, and English languages.

```

11:28:44: Received:
OPTIONS sip:36601@172.18.193.98:5060;user=phone SIP/2.0
Via: SIP/2.0/UDP 172.18.193.120:5060
From: "user" <sip:36602@172.18.193.120>
To: <sip:36601@172.18.193.98>
Date: Mon, 01 Mar 1993 02:55:01 GMT
Call-ID: BB8A5738-14EE11CC-8008B310-2C18B10E@172.18.193.120
Accept: application/sdp
CSeq: 110 OPTIONS
Contact: <sip:36601@172.18.193.98:5060>
Content-Length: 0
11:28:44: Sent:
SIP/2.0 200 OK
Via: SIP/2.0/UDP 172.18.193.120:5060
From: "user" <sip:36602@172.18.193.120>
To: <sip:36601@172.18.193.98>;tag=2768F24-1DB2
Date: Mon, 01 Mar 1993 11:28:44 GMT
Call-ID: BB8A5738-14EE11CC-8008B310-2C18B10E@172.18.193.120
Server: Cisco-SIPGateway/IOS-12.x
Content-Type: application/sdp
CSeq: 110 OPTIONS
Supported: 100rel
Accept-Language: yo, sd;q=0.234, en;q=0.123
Allow: INVITE, OPTIONS, BYE, CANCEL, ACK, PRACK, COMET, Refer , SUBSCRIBE, NOTIFY, INFO
Accept: application/sdp
Allow-Events: telephone-event
Content-Length: 170
v=0
o=CiscoSystemsSIP-GW-UserAgent 7292 5756 IN IP4 172.18.193.98
s=SIP Call
c=IN IP4 172.18.193.98
t=0 0
m=audio 0 RTP/AVP 18 0 8 4 2 15 3
c=IN IP4 172.18.193.98

```

## SIP Enhanced 180 Provisional Response Handling

The SIP Enhanced 180 Provisional Response Handling feature provides the ability to enable or disable early media cut-through on Cisco IOS gateways for SIP 180 response messages. The feature allows you to specify whether 180 messages with Session Description Protocol (SDP) are handled in the same way as 183 responses with SDP. The 180 Ringing message is a provisional or informational response used to indicate that the

INVITE message has been received by the user agent and that alerting is taking place. The 183 Session Progress response indicates that information about the call state is present in the message body media information. Both 180 and 183 messages may contain SDP which allow an early media session to be established prior to the call being answered.

Prior to the implementation of this feature, Cisco gateways handled a 180 Ringing response with SDP in the same manner as a 183 Session Progress response; that is, the SDP was assumed to be an indication that the far end would send early media. Cisco gateways handled a 180 response without SDP by providing local ringback, rather than early media cut-through. This feature provides the capability to ignore the presence or absence of SDP in 180 messages, and as a result, treat all 180 messages in a uniform manner. The SIP Enhanced 180 Provisional Response Handling feature introduces the new disable-early-media 180 command that enables you to specify which call treatment, early media or local ringback, is provided for 180 responses with SDP.

The table below shows the call treatments available with this feature.

**Table 4: Call Treatments with SIP Enhanced 180 Provisional Response Handling Feature**

Response Message	Cisco IOS VoiceXML Status	Treatment
180 response with SDP	Enabled (default)	Early media cut-through
180 response with SDP	Disabled	Local ringback
180 response without SDP	Not affected by the new feature	Local ringback
183 response with SDP	Not affected by the new feature	Early media cut-through

## SIP Extensions for Caller Identity and Privacy

To configure the SIP Extensions for Caller Identity and Privacy feature, you must understand the following concepts:

### Privacy Screening and Presentation Indicators

Cisco implements this feature on SIP trunking gateways by supporting a header, Remote-Party-ID, as defined in the IETF specification, draft-ietf-privacy-.02.txt, SIP Extensions for Caller Identity and Privacy. The Remote-Part-ID header identifies the calling party and carries presentation and screening information. In previous SIP implementations, the From header was used to indicate calling party identity, and once defined in the initial INVITE request, could not be modified for that session. Implementing the Remote-Part-ID header, which can be modified, added, or removed as a call session is being established, overcomes previous limitations and enables call participant privacy indication, screening, and verification. The feature uses the Remote-Part-ID header to support translation capability between Integrated Services Digital Networks (ISDN) messages and Remote-Party-ID SIP tags. The SIP header also enables support for certain telephony services, and some regulatory and public safety requirements, by providing screening and presentation indicators.

The SIP Extensions for Caller Identity and Privacy feature introduces command-line interface (CLI) commands to enable remote-party-id translations and to configure alternative calling information treatments for calls entering the SIP trunking gateway. Configurable treatment options are:

- Calling name and number pass-through (default).
- No calling name or number sent in the forwarded Setup message.
- Calling name unconditionally set to the configured string in the forwarded Setup message.

- Calling number unconditionally set to the configured string in the forwarded Setup message.

You can configure alternative calling information treatments for calls exiting the SIP trunking gateway. Configurable treatment options are as follows:

- Calling name and number pass-through (default).
- No calling name or number sent in the forwarded INVITE message.
- Display-name of the From header unconditionally set to the configured string in the forwarded INVITE message.
- User part of the From header unconditionally set to the configured string in the forwarded INVITE message.
- Display-name of the Remote-Party-ID header unconditionally set to the configured string in the forwarded INVITE message.
- User part of the Remote-Party-ID header unconditionally set to the configured string in the forwarded INVITE message.

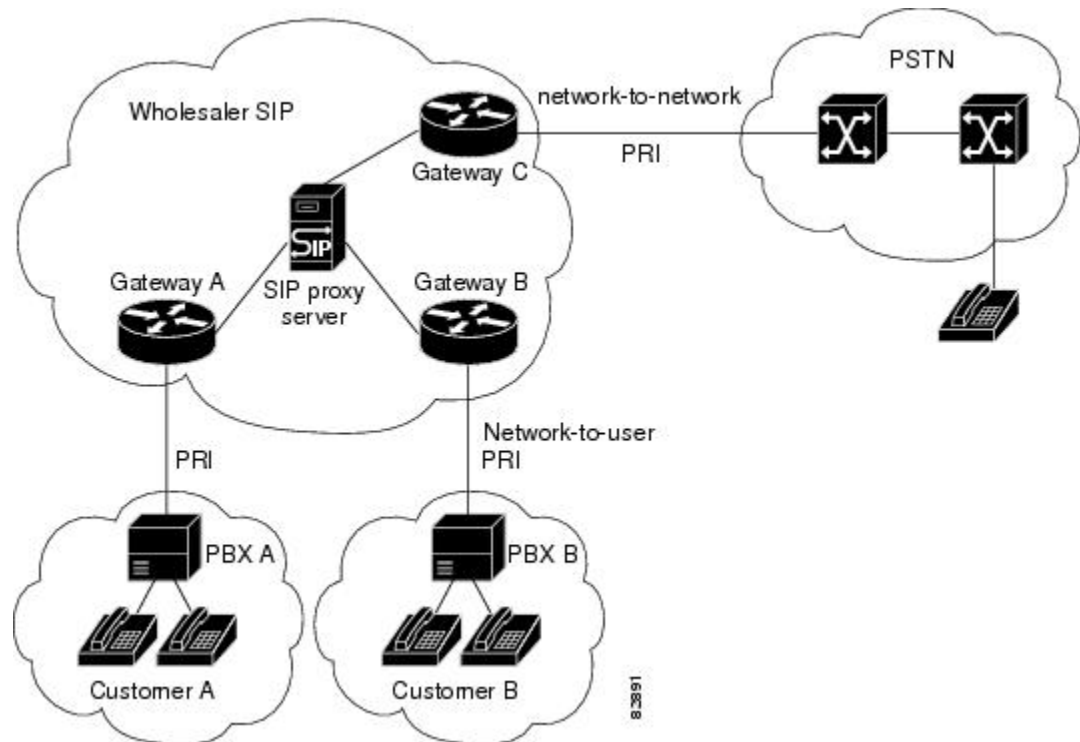
## Remote-Party-ID Implementation

This section discusses the implementation of the Remote-Party-ID feature in a SIP network. Before the implementation of this feature, there was no mechanism to modify the contents of the From header field. With the feature enabled, SIP gateways provide translation capability for ISDN screening and presentation identifiers in call setup messages. SIP gateways and proxy servers require configuration to support Remote-Party-ID feature.

The figure below shows a typical network where the feature is implemented. Gateway C is configured for unscreened discard, that is, if the incoming SIP INVITE request does not contain a screened Remote-Party-ID header (;screen=yes), no calling name or number is sent in the forwarded Setup message.



Figure 1: Wholesaler SIP Network



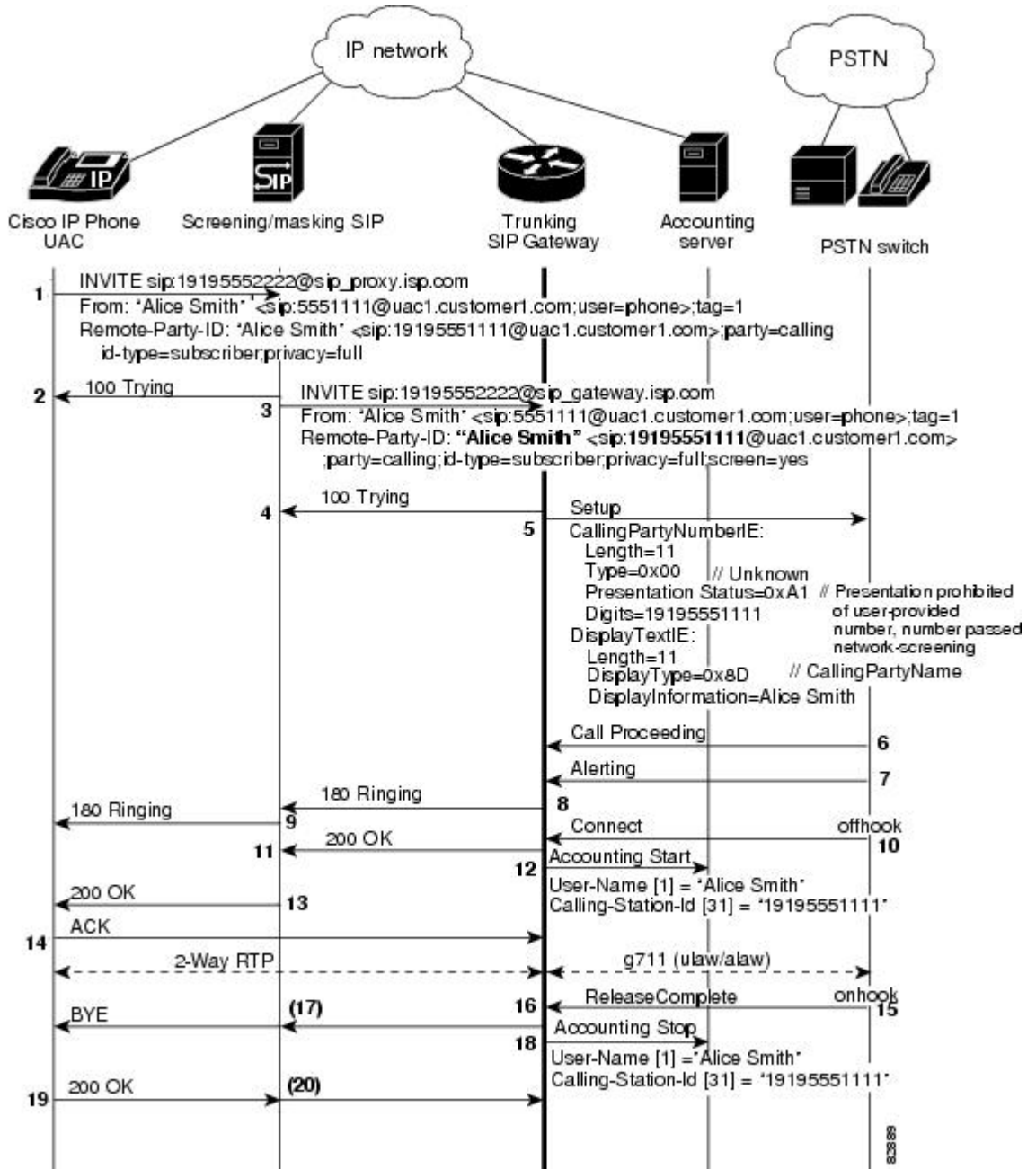
**Note** With respect to privacy and screening indication, it is the responsibility of the proxy server to protect display-name information and enforce privacy policies at the administrative boundary.

The figures in the Inbound and Outbound Call Flows section illustrate various calling information treatment options using the commands available with the feature. Calling information treatment is determined by the parameters specified in the Setup message and Remote-Party-ID configuration on the SIP gateway.

## Inbound and Outbound Call Flows

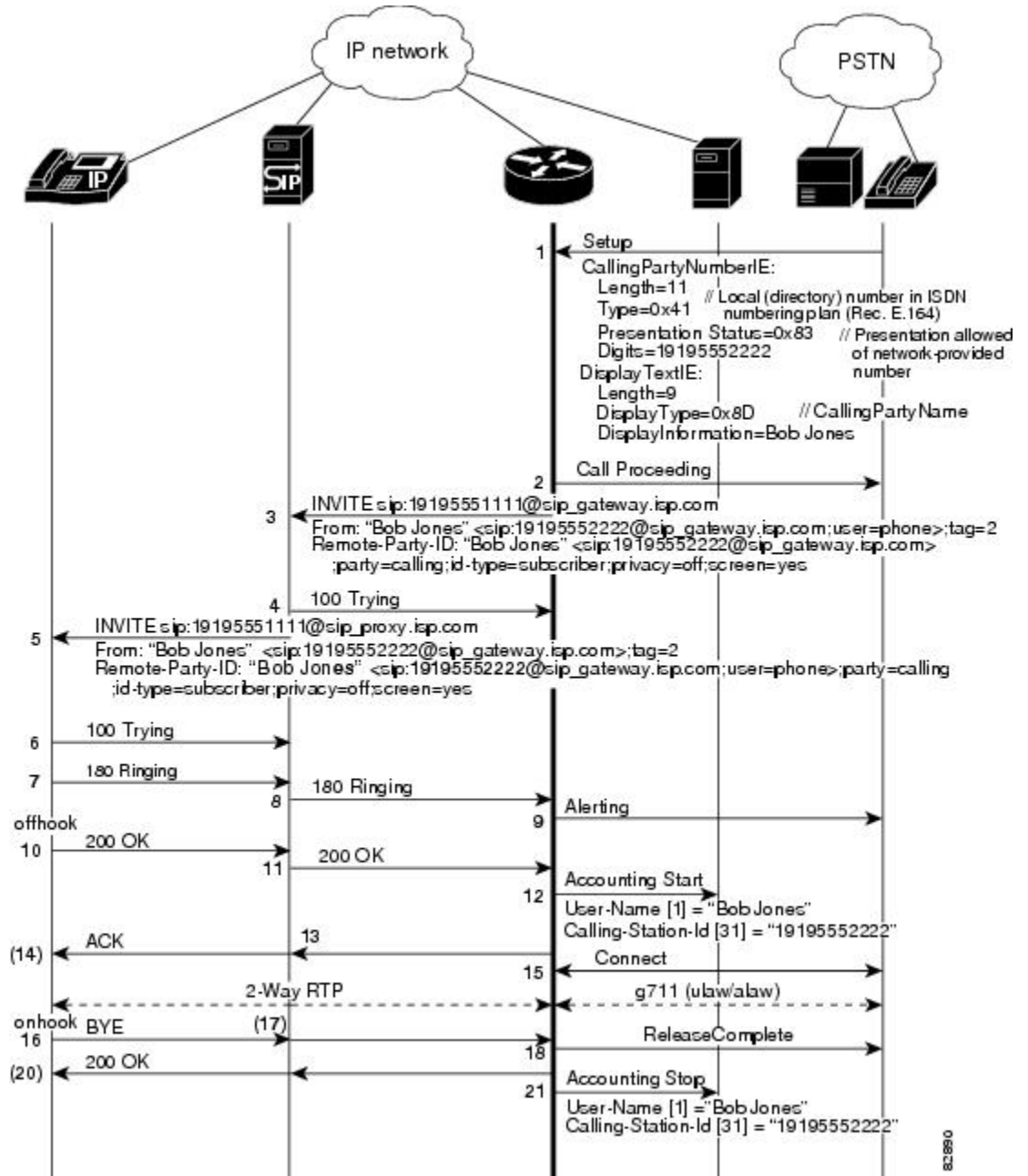
This section presents inbound and outbound call flows for the Remote-Party-ID feature. The figure below shows the SIP-to-PSTN default behavior where the calling party name and number are passed. The feature enables this treatment by default and no configuration is required.

Figure 2: SIP-to-PSTN Default Call Flow with Remote-Party-ID



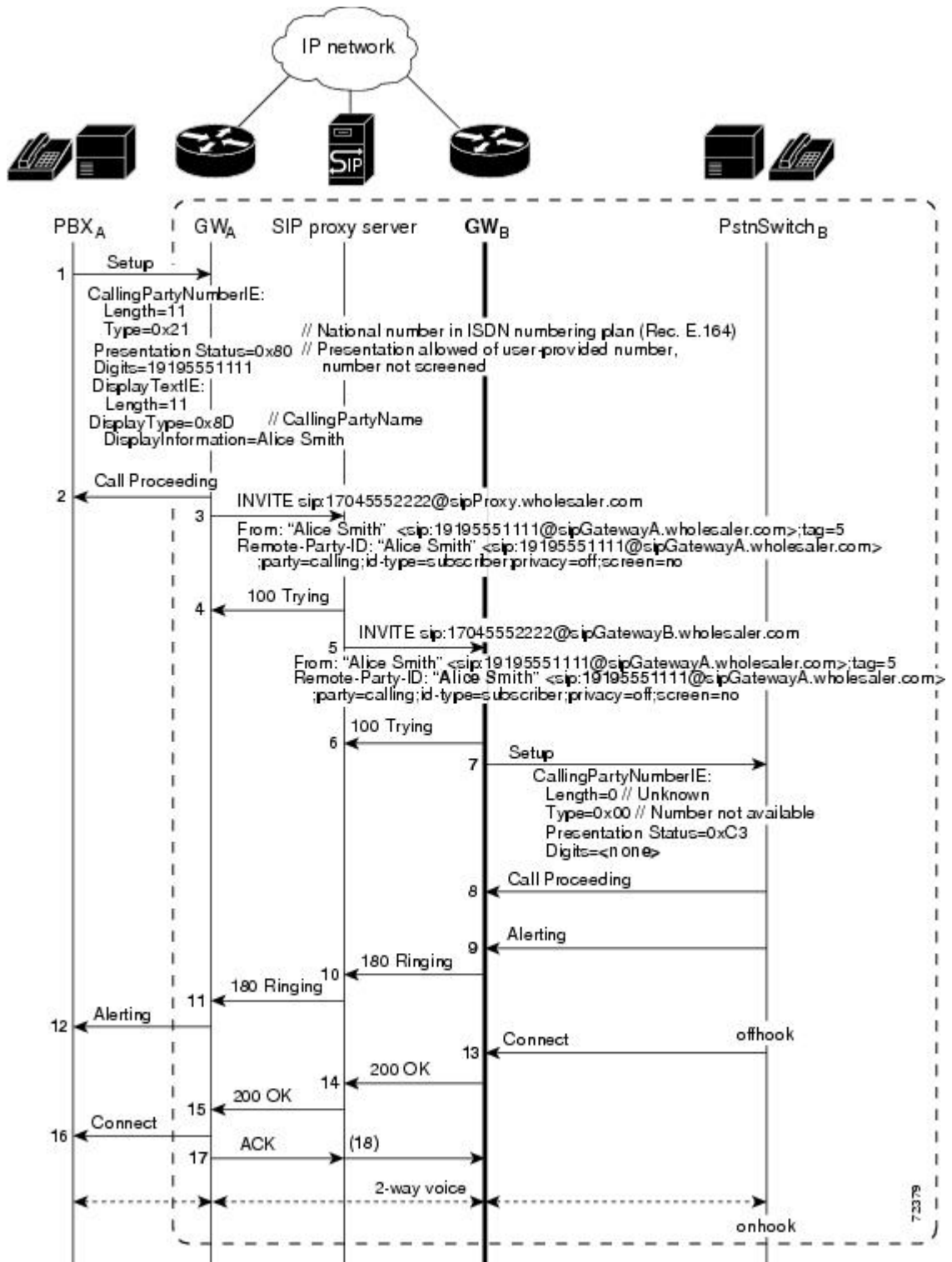
The figure below shows the PSTN-to-SIP default behavior where the calling party name and number are passed. This feature enables this treatment by default and no configuration is required.

Figure 3: PSTN-to-SIP Default Call Flow with Remote-Party-ID Translation, No Privacy Requested



The figure below shows the call flow for discarding the calling name and number at Gateway B. The Setup message includes ISDN information elements (IEs) that specify calling information treatment. The INVITE message from Gateway A includes the corresponding Remote-Party-ID SIP tags.

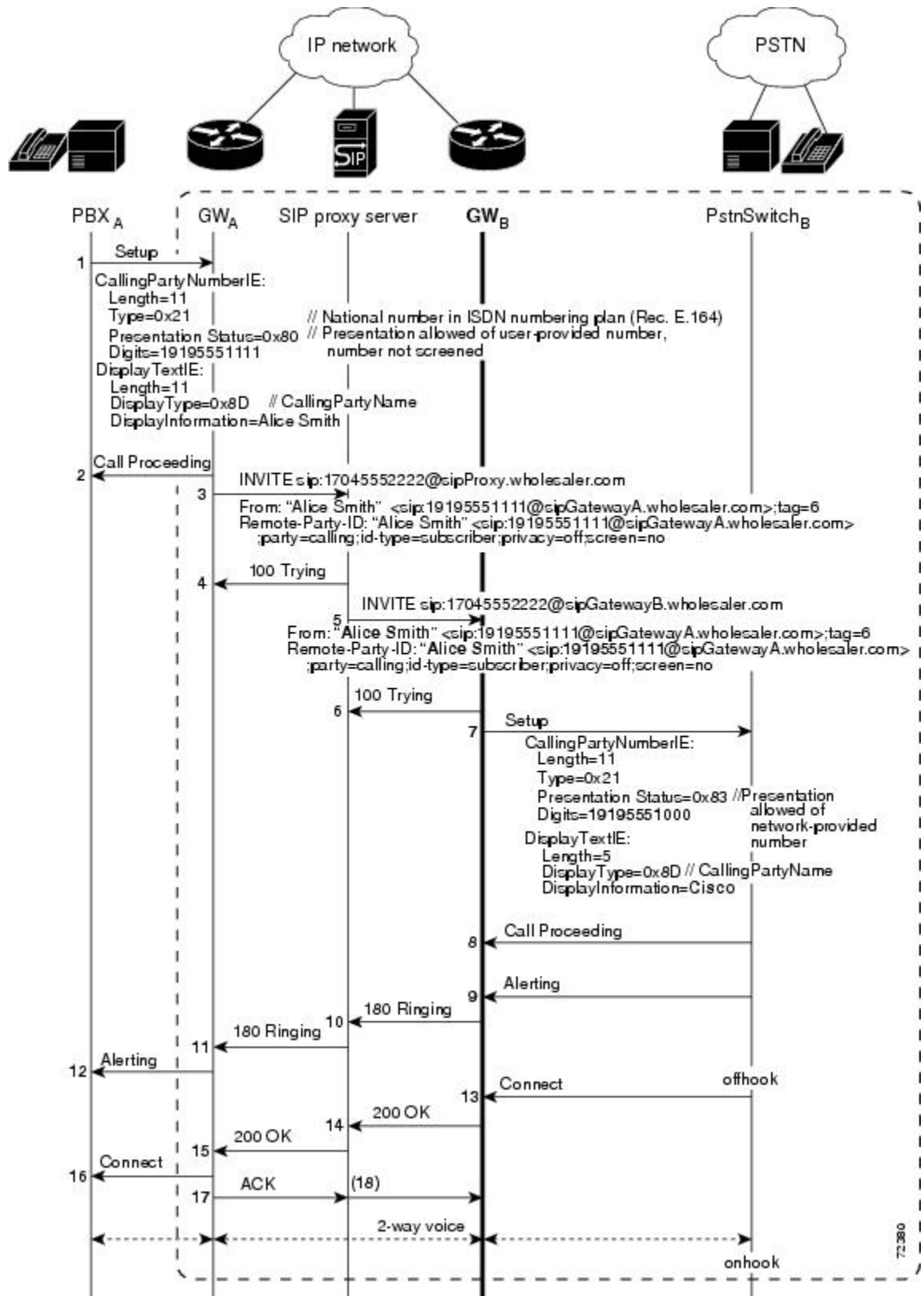
Figure 4: Discarding Calling Name and Number at Gateway



The figure below shows Gateway B overriding the calling name and number received in the Setup message from Gateway A. To configure Gateway B to override calling name and number, use the following commands:

- **remote-party-id**
- calling-info sip-to-pstn name set name
- calling-info sip-to-pstn number set number

*Figure 5: Overriding Calling Name and Number at Gateway*



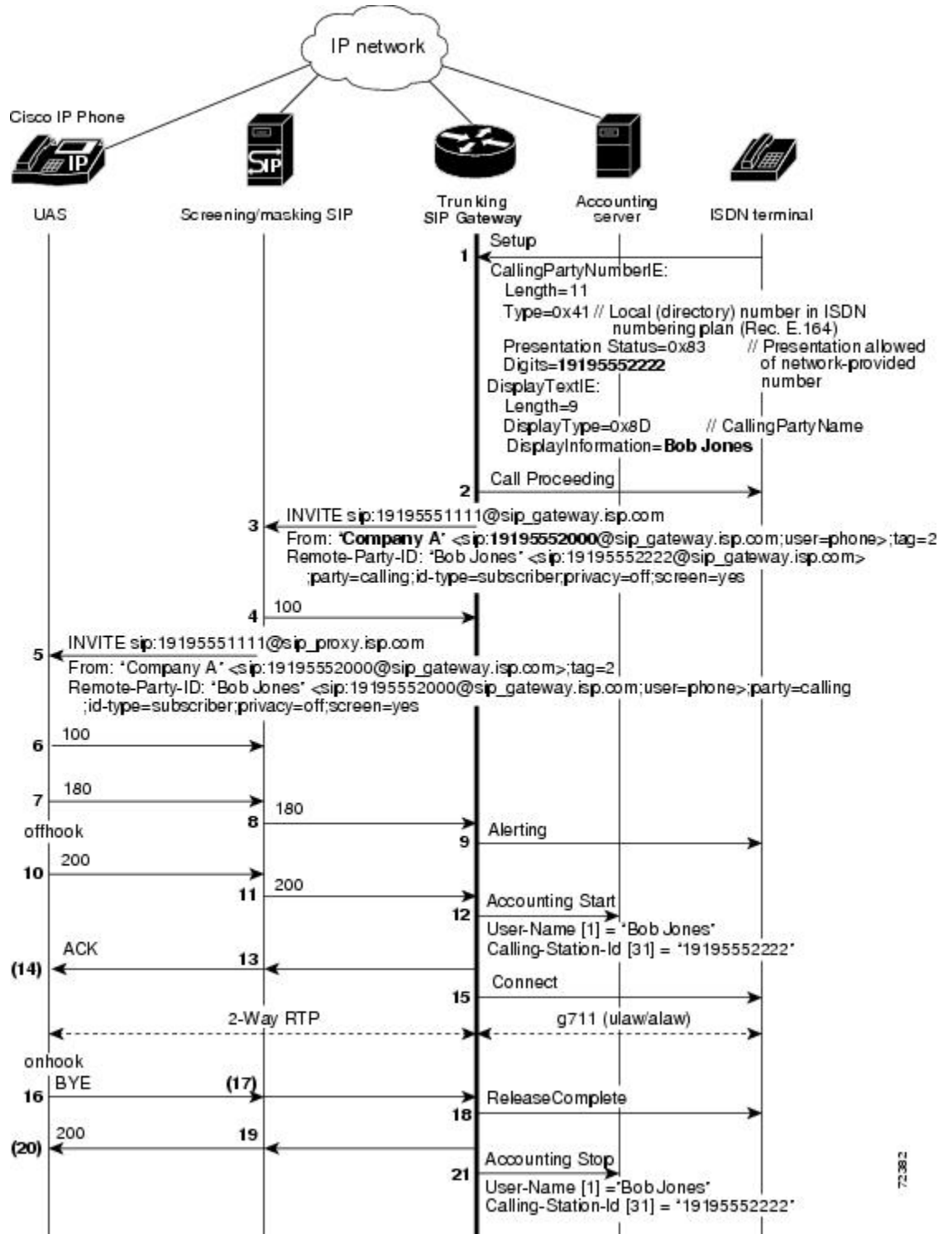
72380

In the figure below the trunking SIP gateway is configured to override the calling name and number of the From header. To configure this call treatment option, use the following commands:

- remote-party-id
- calling-info pstn-to-sip from name set name
- calling-info pstn-to-sip from number set number

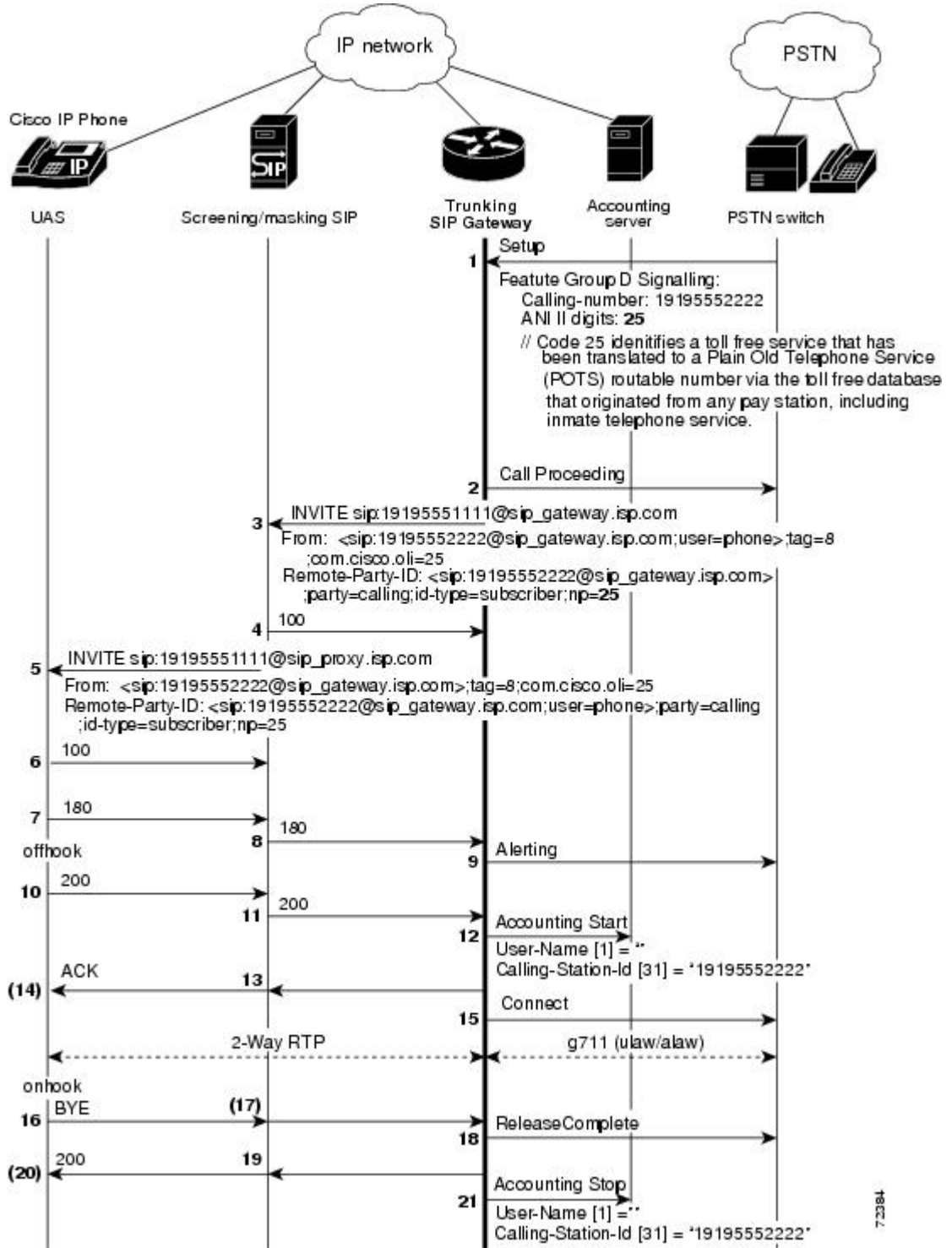


Figure 6: Overriding Calling Name and Number of From Header



The figure below shows translation of OLI or ANI II digits for a billing application. The Remote-Party-ID feature enables this treatment by default; no configuration tasks are required. If the feature was disabled by using the no remote-party-id command, use the remote-party-id command to re-enable the feature.

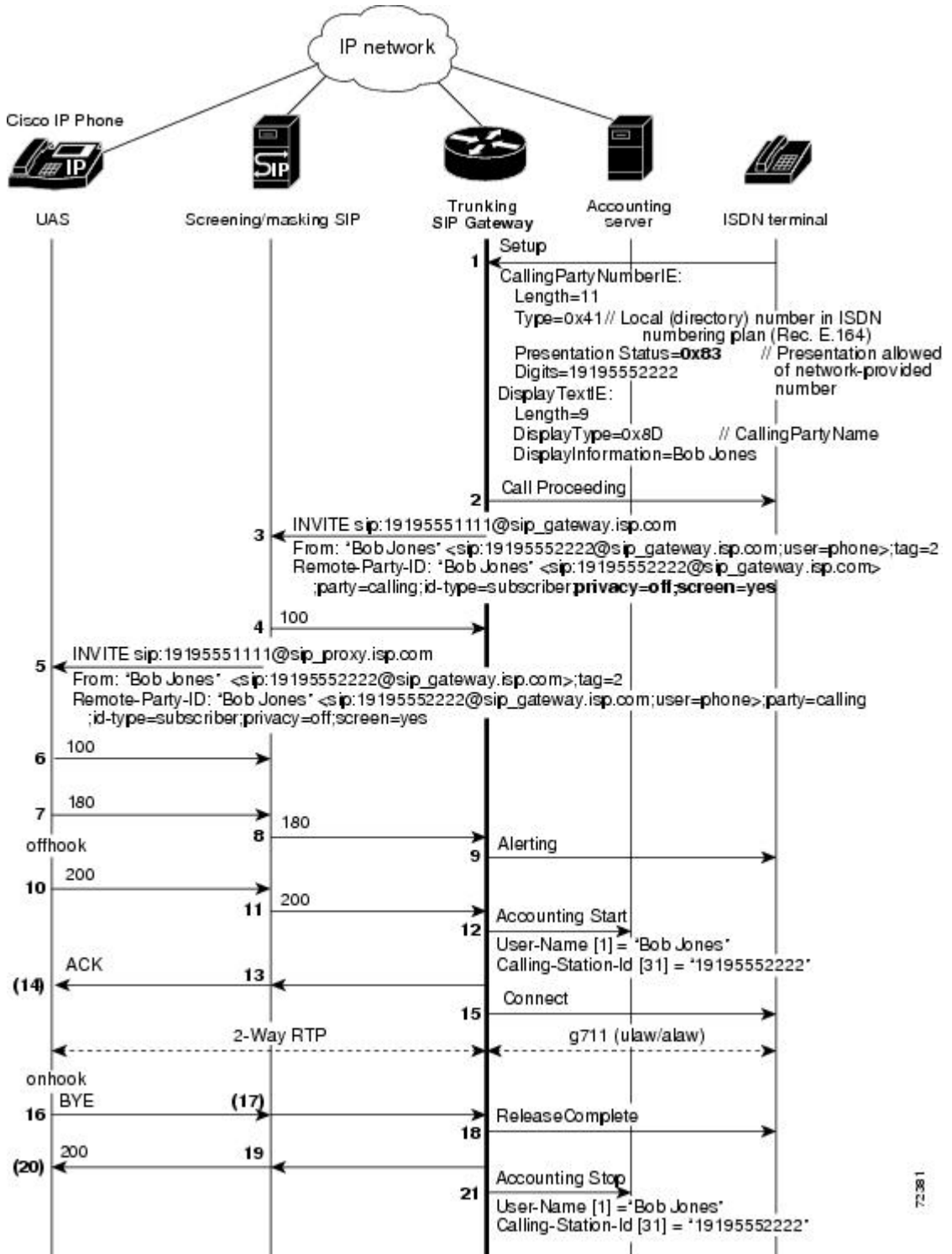
Figure 7: Passing OLI from CAS to SIP



72984

The next two figures show the SIP trunking gateway capability to provide translation between ISDN screening and presentation identifiers and SIP Remote-Party-ID extensions. The two figures show the difference in call treatment, with and without privacy requested. With no privacy requested, the calling party name and number are passed unchanged.

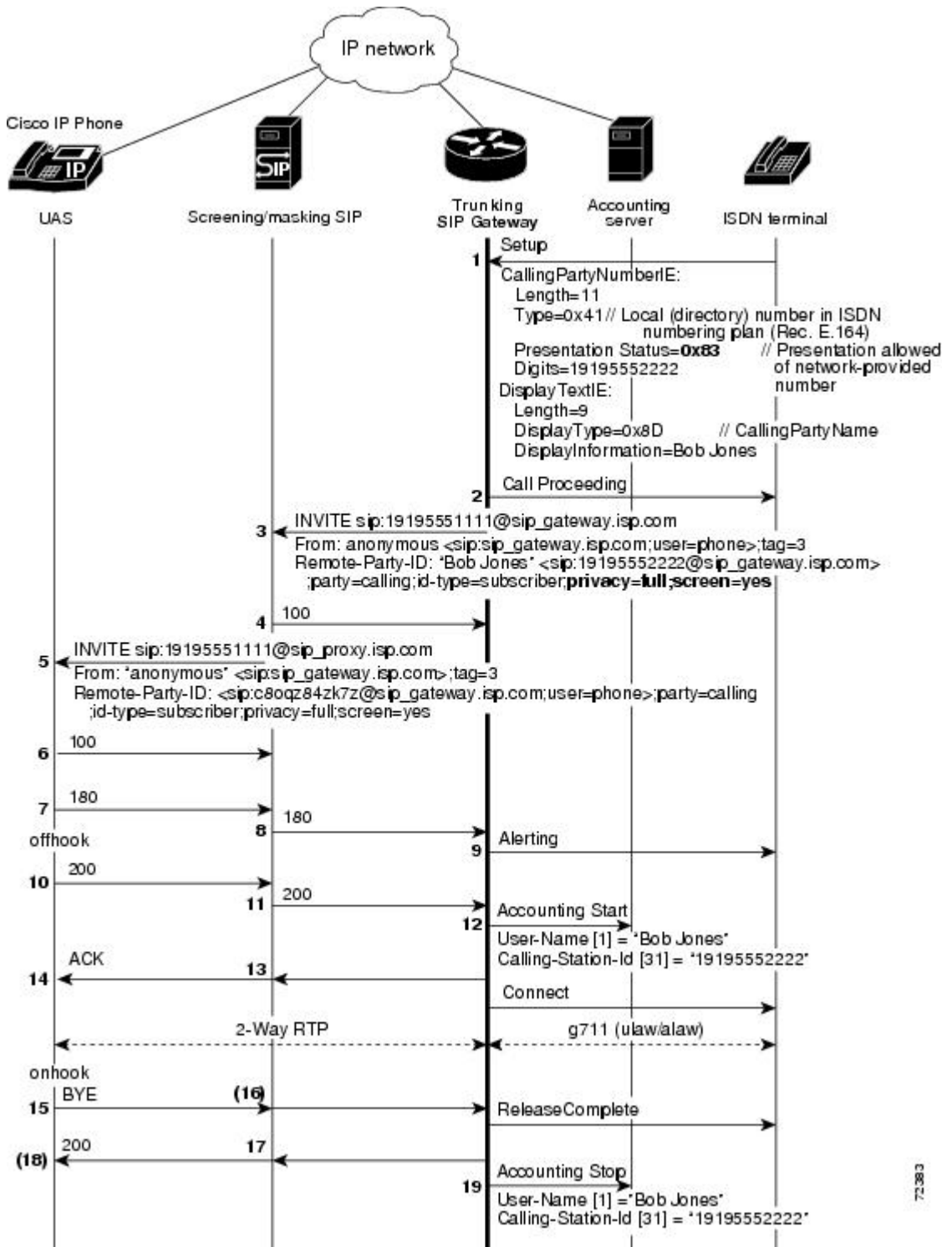
Figure 8: PSTN-to-SIP Call Flow with Remote-Party-ID Translation, No Privacy Requested



72381

With privacy requested, as shown in the figure below, screened identity information is still logged in accounting records for billing information, but the user field is not populated in the From header of the outgoing INVITE message, and the display-name is populated with “anonymous.”

Figure 9: PSTN-to-SIP Call Flow with Remote-Party-ID, Privacy Requested



7-383

## Remote-Party-ID in SIP and PSTN Messages

The ability to provide marking, screening, and PSTN translation of identity information to and from Remote-Party-ID extensions is supported in SIP INVITE and PSTN messages. This section discusses the formats of SIP INVITE and PSTN messages, and has the following subsections:

### Remote-Party-ID Header

The SIP Remote-Party-ID header identifies the calling party and includes user, party, screen and privacy headers that specify how a call is presented and screened. The header contains a URL and an optional display name that identifies a user. A valid Remote-Party-ID header may be either a SIP URL or a TEL URL.



**Note** For information on header syntax, see "Remote-Party-ID Syntax" and "Screening and Presentation Information".

The following example shows representative Remote-Party-ID headers, including user, party, screen, and privacy.

```
02:32:17:Received:
INVITE sip:3331000@172.27.184.118:5060;user=phone SIP/2.0
Via:SIP/2.0/UDP 10.0.0.1:5070
Supported:org.ietf.sip.100rel
From:"alice" <sip:555-1001@10.0.0.1:5070>
To:sip:555-1002@172.27.184.118:5060
Remote-Party-ID:"Alice Smith"
<sip:5551111@192.0.2.67;user=phone>;party=calling;screen=no;privacy=off
Call-ID:00000001@10.0.0.1:5070
CSeq:1 INVITE
Contact:"alice" <sip:10.0.0.1:5070>
Content-Type:application/sdp
v=0
o=- 2890844526 2890844526 IN IP4 A3C47F2146789F0
s=-
c=IN IP4 10.0.0.1
t=36124033 0
m=audio 49170 RTP/AVP 0
```

### Remote-Party-ID Syntax

Remote-Party-ID fields identify the calling party depending upon how the field is marked. If the party is unmarked, a Remote-Party-ID in a header represents the identity of the calling party.

Remote-Party-ID follows the Augmented Backus-Naur Format (ABNF). Refer to draft-ietf-sip-privacy-02.txt for the definitive specification. Fields are as follows:

- Remote-Party-ID = "Remote-Party-ID" ":" [display-name] "<" addr-spec ">" \*(";" rpi-token)
- rpi-token = rpi-screen | rpi-pty-type | rpi-id-type | rpi-privacy | other-rpi-token
- rpi-screen = "screen" "=" ("no" | "yes")
- rpi-pty-type = "party" "=" ( "calling" | "called" | token )
- rpi-id-type = "id-type" "=" ( "subscriber" | "user" | "alias" | "return" | "term" | token )
- rpi-privacy = "privacy" "=" 1#( ("full" | "name" | "uri" | "off" | token ) [ "-" ( "network" | token ) ] )
- other-rpi-token = ["-"] token ["=" (token | quoted-string)]

## ISDN Syntax

ISDN messages follow the format specified in ISDN Primary Rate Interface Call Control Switching and Signalling Generic Requirements for Class II Equipment, TR-NWT-001268, Revisions 1-4, Telcordia Technologies Technical Reference, 2001 and ISDN Basic Rate Interface Call Control Switching and Signalling Generic Requirements, GR-268-CORE, July 1998, to signal call control. ISDN messages are composed of information elements (IEs). The Cisco IOS VoiceXML feature uses Calling Party Number and Display Text IEs to provide specified screening and presentation treatment. The Calling Party Number IE specifies the origin of the calling number and presentation status, and the Display Text IE supplies calling party name information that is formatted for display by a terminal for a human user. See the Setup message in "ISDN Syntax" for sample IE information.

### Screening and Presentation Information

The Remote-Party-ID header and ISDN Setup messages contain tags used to specify screened identity information. The table below lists translation of screening and presentation information included in the Remote-Party-ID SIP tags for SIP to PSTN networks.

**Table 5: SIP to PSTN Translation of Screening and Presentation Information**

Remote-Party-ID SIP Tags	PSTN Octet 3A
;privacy=off;screen=no	Presentation allowed of user-provided number, number not screened (0x80)
;privacy=off;screen=yes	Presentation allowed of user-provided number, number passed network screening (0x81)
;privacy=[full uri name];screen=no	Presentation prohibited of user-provided number, number not screened (0xA0)
;privacy=[full uri name];screen=yes	Presentation prohibited of user-provided number, number passed network screening (0xA1)
;screen=no	Presentation allowed of user-provided number, number not screened (0x80)
;screen=yes	Presentation allowed of user-provided number, number passed network screening (0x81)
;privacy=off	Presentation allowed of user-provided number, number not screened (0x80)
;privacy=[full uri name]	Presentation prohibited of user-provided number, number not screened (0xA0)
(no screen or privacy tags)	Presentation allowed of user-provided number, number not screened (0x80)

The table below provides the same translation for PSTN to SIP networks.



**Table 6: PSTN to SIP Translation of Screening and Presentation Information**

<b>PSTN Octet 3A</b>	<b>Remote-Party-ID SIP Tags</b>
Presentation allowed of user-provided number, number not screened (0x80)	;privacy=off;screen=no
Presentation allowed of user-provided number, number passed network screening (0x81)	;privacy=off;screen=yes
Presentation allowed of user-provided number, number failed network screening (0x82)	;privacy=off;screen=no
Presentation allowed of network-provided number (0x83)	;privacy=off;screen=yes
Presentation prohibited of user-provided number, number not screened (0xA0)	;privacy=full;screen=no
Presentation prohibited of user-provided number, number passed network screening (0xA1)	;privacy=full;screen=yes
Presentation prohibited of user-provided number, number failed network screening (0xA2)	;privacy=full;screen=no
Presentation prohibited of network-provided number (0xA3)	;privacy=full;screen=yes
Number not available (0xC3)	(no screen or privacy tags are sent)

The table below lists the corresponding translation for ISDN tags in binary and hex formats.

**Table 7: ISDN Tags in Binary and Hex Formats**

<b>Binary (Bits)</b>	<b>Hex</b>	<b>Meaning</b>
<b>8 7 6 5 4 3 2 1</b>		
1 0 0 0 0 0 0 0	0x80	Presentation allowed of user-provided number, number not screened
1 0 0 0 0 0 0 1	0x81	Presentation allowed of user-provided number, number passed network screening
1 0 0 0 0 0 1 0	0x82	Presentation allowed of user-provided number, number failed network screening
1 0 0 0 0 0 1 1	0x83	Presentation allowed of network-provided number
1 0 1 0 0 0 0 0	0xA0	Presentation prohibited of user-provided number, number not screened
1 0 1 0 0 0 0 1	0xA1	Presentation prohibited of user-provided number, number passed network screening
1 0 1 0 0 0 1 1	0xA3	Presentation prohibited of network-provided number
1 1 0 0 0 0 1 1	0xC3	Number not available

## Benefits of SIP Extensions for Caller Identity and Privacy

- Expands PSTN interoperability

- Supports the ability to override privacy and screening indicators
- Enables network verification and screening of a call participant identity by SIP proxy servers
- Supports logging of screened identity information in accounting records for billing information
- Provides enhanced subscriber information that supports the enabling of service creation platforms and application servers for service providers
- Allows the service provider enhanced control of the ability to identify a subscriber and its qualifications within the network

## SIP Via Header Support

Each SIP request includes a Via header that may have an maddr (multiple address) parameter. The maddr parameter indicates an alternate address for where to send the SIP response.

The value of the maddr parameter can be an IP address or a hostname. If a maddr parameter is a hostname, the SIP stack performs a DNS query to resolve the name to an IP address. In compliance with RFC 3261, this feature allows the SIP request sender to specify the response destination using the maddr parameter in the Via header.



**Note** Prior to Cisco IOS Release 15.1(1)T, replies to SIP requests could be sent only to the source IP address (the IP address where the SIP request originated).

The sender of the SIP request is a far-end SIP endpoint with which the Cisco IOS gateway is communicating. The far-end endpoint manages SIP dialogs across multiple nodes. The far-end endpoint is a SIP INVITE request to initiate a new dialog with the Cisco IOS gateway. It uses the maddr parameter in the Via header to specify a destination address for SIP responses. SIP dialog to the Cisco IOS gateway can originate from one IP address, but subsequent responses go to the destination address specified in the maddr parameter.

The following SIP request shows a destination address specified using the maddr parameter in the Via header (192.168.199.200). The SIP response is sent to this address.

```
INVITEsip:1234@10.105.209.114:5060 SIP/2.0
Via: SIP/2.0/TCP 192.168.199.200:5060; branch=z9hg4K0245fc9a5; maddr=192.168.10.11
From: <sip:1234@10.105.209.114>
Date: Tue, 23 Mar 2010 21:42:14 GMT
Call-ID: f06cc480-ba9135b6-1-c8c71ac@192.168.199.200
Supported: timer, resource-priority, replaces
Min-SE: 1800
User-Agent: Cisco-CUCM8.0
Allow: INVITE, OPTIONS, INFO, BYE, CANCEL, ACK, PRACK, UPDATE, REFER, SUBSCRIBE, NOTIFY
CSeq: 101 INVITE
Contact: <sip:3001@192.168.199.200:5060;transport=tcp>
Expires: 1800
Allow-Events: presence, kpml
Supported: X-Cisco-srtp-fallback
Support: Geolocation
Call-Info: <sip:192.168.199.200:5060>;method="NOTIFY; Event=telephone-event;Duration=500"
Cisco-Guid: 4033660032-3130078646-0000000001-3368489644
Session Expires: 1800
P-Asserted-Identity: <sip:3001@192.168.199.200>
Content-Length: 0
```

## SIP INVITE Request with Malformed Via Header

A SIP INVITE requests that a user or service participate in a session. Each INVITE contains a Via header that indicates the transport path taken by the request so far, and where to send a response.

In the past, when an INVITE contained a malformed Via header, the gateway would print a debug message and discard the INVITE without incrementing a counter. However, the printed debug message was often inadequate, and it was difficult to detect that messages were being discarded.

The SIP INVITE Request with Malformed Via Header feature provides a response to the malformed request. A counter, *Client Error: Bad Request*, increments when a response is sent for a malformed Via field. *Bad Request* is a class 400 response and includes the explanation *Malformed Via Field*. The response is sent to the source IP address (the IP address where the SIP request originated) at User Datagram Protocol (UDP) port 5060.



---

**Note** This feature applies to messages arriving on UDP, because the Via header is not used to respond to messages arriving on TCP.

---

Feature benefits include the following:

- The system now increments a counter and sends a response, rather than simply discarding an INVITE message that contains a malformed Via header.
- The counter provides a useful and immediate indication that an INVITE message has been discarded, and the response allows the result to be propagated back to the sender.

## SIP Session Timer Support

The SIP Session Timer Support feature adds the capability to periodically refresh SIP sessions by sending repeated INVITE requests. The repeated INVITE requests (re-INVITES), are sent during an active call leg to allow user agents or proxies to determine the status of a SIP session. Without this keepalive mechanism, proxies that remember incoming and outgoing requests (stateful proxies) may continue to retain call state needlessly. If a user agent fails to send a BYE message at the end of a session or if the BYE message is lost because of network problems, a stateful proxy does not know that the session has ended. The re-INVITES ensure that active sessions stay active and completed sessions are terminated.

In addition to re-INVITES, UPDATE can also be used as a method for session keepalives. The SIP stack supports both re-INVITE and UPDATE. The gateway continues to use re-INVITE for session refresh.

The SIP Session Timer Support feature also adds two new general headers that are used to negotiate the value of the refresh interval.

- A Session-Expires header is used in an INVITE if the user-agent client (UAC) wants to use the session timer.
- The Minimum Session Expiration (Min-SE) header conveys the minimum allowed value for the session expiration.

## Role of the User Agents

The initial INVITE request establishes the duration of the session and may include a Session-Expires header and a Min-SE header. These headers indicate the session timer value required by the UAC. A receiving

user-agent server (UAS) or proxy can lower the session timer value, but not lower than the value of the Min-SE header. If the session timer duration is lower than the configured minimum, the proxy or UAS can also send out a 422 response message. If the UAS or proxy finds that the session timer value is acceptable, it copies the Session-Expires header into the 2xx class response.

A UAS or proxy can also insert a Session-Expires header in the INVITE if the UAC did not include one. Thus a UAC can receive a Session-Expires header in a response even if none was present in the request.

In the 2xx response, the *refresher* parameter in the Session-Expires header indicates who performs the re-INVITEs or UPDATE. For example, if the parameter contains the value UAC, the UAC performs the refreshes. For compatibility issues, only one of the two user agents needs to support the session timer feature, and in that case, the user agent that supports the feature performs the refreshes.

Re-INVITEs are processed identically to INVITE requests, but go out in predetermined session intervals. Re-INVITEs carry the new session expiration time. The user agent that is responsible for generating re-INVITE requests sends a re-INVITE out before the session expires. If there is no response, the user agent sends a BYE request to terminate the call before session expiration. If a re-INVITE is not sent before the session expiration, either the UAC or the UAS can send a BYE.

If the 2xx response does not contain a Session-Expires header, there is no session expiration and re-INVITEs do not need to be sent.

## Session-Expires Header

The Session-Expires header conveys the session interval for a SIP call. It is placed in an INVITE request and is allowed in any 2xx class response to an INVITE. Its presence indicates that the UAC wishes to use the session timer for this call. Unlike the SIP-Expires header, it can only contain a delta-time, which is the current time, plus the session interval from the response.

For example, if a UAS generates a 200 OK response to a INVITE that contained a Session-Expires header with a value of 90 seconds (1.5 minutes), the UAS computes the session expiration as 1.5 minutes after the time when the 200 OK response was sent. For each proxy, the session expiration is 1.5 minutes after the time when the 2xx was received or sent. For the UAC, the expiration time is 1.5 minutes after the receipt of the final response.

When the gateway acts as an UAS, it is responsible for refreshes. The refresh interval is a minimum of 32 seconds, or one-third the refresh interval. When the gateway act as an UAC, the refresh interval is one-half the refresh interval.

If the session is not refreshed, the minimum time to send a BYE before the session expires is 32 seconds.

The recommended value for the Session-Expires header is 90 seconds.

The syntax of the Session-Expires header is as follows:

```
Session-Expires = ("Session-Expires" |
"x"
) ":" delta-seconds
                [refresher]
refresher       = ";" "refresher" "=" "UAS"|"UAC"
```

The *refresher* parameter is optional in the initial INVITE, although the UAC can set it to UAC to indicate that it will do the refreshes. The 200 OK response must have the refresher parameter set.

## Min-SE Header

Because of the processing load of INVITE requests, the proxy, UAC, and UAS can have a configured minimum timer value that they can accept. The **min-se** (SIP) command sets the minimum timer, and it is conveyed in the Min-SE header in the initial INVITE request.

When making a call, the presence of the Min-SE header informs the UAS and any proxies of the minimum value that the UAC accepts for the session timer duration, in units of delta-seconds. The default value is 90 seconds (1.5 minutes). By not reducing the session interval below the value set, the UAS and proxies prevent the UAC from having to reject a call with a 422 error. Once set, the **min-se** command value affects all calls originated by the router. If the Min-SE header is not present, the user agent accepts any value.

The syntax of the Min-SE header is:

```
Min-SE = "Min-SE" ":" delta-seconds
```

## 422 Response Message

If the value of the Session-Expires header is too small, the UAS or proxy rejects the call with a 422 *Session Timer Too Small* response message. With the 422 response message, the proxy or UAS includes a Min-SE header indicating the minimum session value it can accept. The UAC may then retry the call with a larger session timer value.

If a 422 response message is received after an INVITE request, the UAC can retry the INVITE.

## Supported and Require Headers

The presence of the *timer* argument in the Supported header indicates that the user agent supports the SIP session timer. The presence of the *timer* argument in the Require header indicates that the opposite user agent must support the SIP session timer for the call to be successful.

## Benefits of SIP Session Timer Support

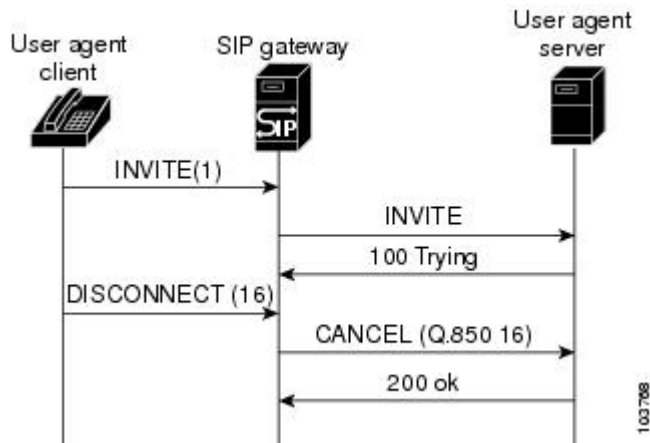
- This feature provides a periodic refresh of SIP sessions. The periodic refresh allows user agents and proxies to monitor the status of a SIP session, preventing hung network resources when network failures occur.
- Only one of the two user-agent or proxy participants in a call needs to have the SIP Session Timer Support feature implemented. This feature is easily compatible with older SIP networks.

## SIP Cisco IOS Gateway Reason Header and Buffered Calling Name Completion

### Reason Header

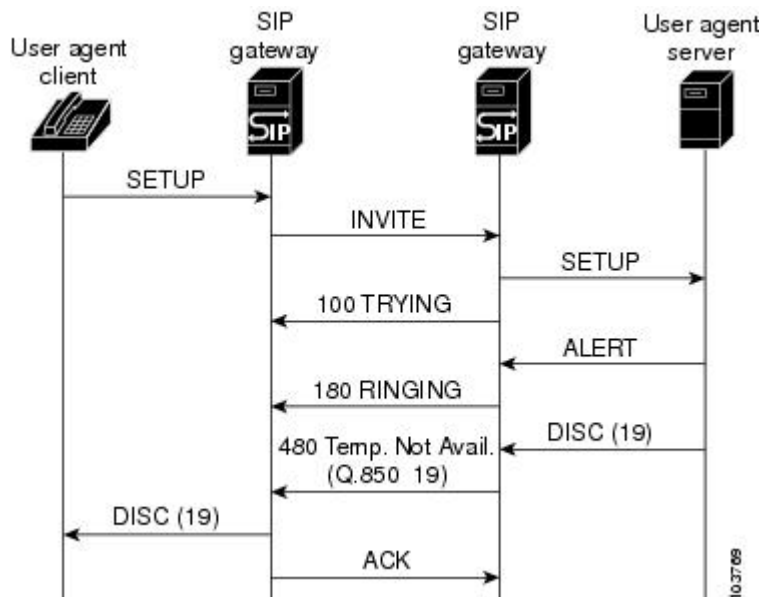
The Reason header facilitates PSTN interworking. This is achieved by having the side receiving a Disconnect message response append a Reason header to the outgoing Bye or Cancel message request and 4xx, 5xx, or 6xx message response, indicating the Q.850 cause code that passed down from the PSTN (see the figure below).

Figure 10: PSTN Interworking Using Reason Header Example



SIP implementations on PSTN gateways are plagued with issues related to mapping ISDN-disconnect message-request cause codes to SIP response status codes, which stem from the mapping on the gateway receiving the disconnect. Specifically, more than one ISDN-disconnect message-request cause code maps to one SIP status code. For example, on SIP gateways, ISDN cause codes 18, 19, and 20 all map to the SIP status code of 480 message response. This makes it impossible to deterministically relay the cause-code value on the remote end. The Reason header can carry the actual cause code (see the figure below).

Figure 11: Reason Header in Action; Extinguishing the Ambiguity in SIP Status Codes



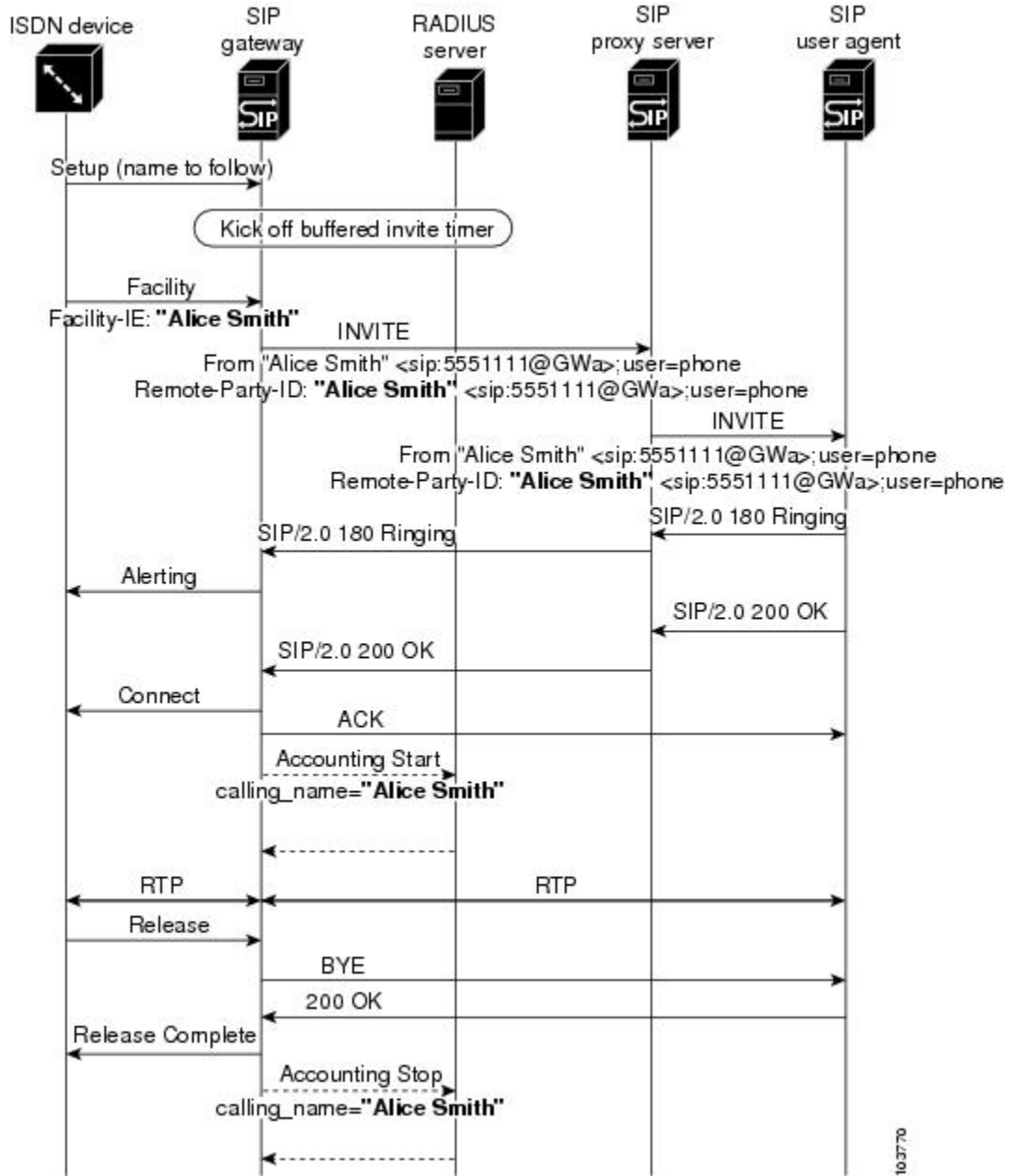
## Buffered Calling-Name Completion

As shown in the figure below, Cisco IOS SIP has always supported receiving calling-name information in the display information element (IE) of a Setup message request. Support for receiving calling-name information in the facility IE of a Setup message request, of a Facility message request, and of a NOTIFY message request were supported through the Support for the ISDN Calling Name Display feature in release 12.3(4)T (refer to the “Configuring SIP DTMF Features” chapter).

The Buffered Calling Name Completion feature adds support for buffering the INVITE message request when the calling-name information is going to arrive in a subsequent facility IE of a Facility message request.

When an originating gateway (OGW) receives a Setup message with an indication that calling-name information is enabled, the configuration is checked for INVITE-message display-name buffering. When buffering is enabled, the INVITE message is buffered until the time specified in the configuration. If a Facility message with display information in the From and Remote Party ID headers of the INVITE message is received, then send it out. If no Facility message is received in the specified time, send out only the INVITE message.

Figure 12: Calling Name in Facility IE of Facility



103770

## SIP SIP Header URL Support and SUBSCRIBE NOTIFY for External Triggers

The SIP: SIP Header/URL Support and SUBSCRIBE/NOTIFY for External Triggers feature provides a mechanism for applications to send and receive SIP headers and to send SUBSCRIBE messages and receive NOTIFY events. Where appropriate, this section discusses separately the features that make up this feature set, the SIP Header Support feature along with the SUBSCRIBE and NOTIFY for External Triggers feature.

Feature benefits include the following:

- Enables the creation of presence-based, subscribe-to-be-notified services that are triggered by events external to a session
- Allows service providers to expand services to include VoiceXML-driven voice browser applications
- Allows the SIP gateway to subscribe to triggered applications and custom event-packages
- Supports distributed voice-web scenarios and call and contact center integration applications by providing access to SIP headers

### Feature Design of SIP Header Support

Prior to the implementation of this feature, voice applications running on the gateway did not have access to headers sent in SIP requests. The SIP Header Passing feature makes SIP headers, the fields which specify session details in SIP messages, available to applications. This feature supports the following capabilities for VoiceXML and Tcl IVR 2.0 applications:

- Set SIP headers for outgoing SIP INVITE messages.
- Obtain information about SIP headers for incoming calls and create session variables to access the headers in VoiceXML document or Tcl IVR 2.0 script.
- Set and obtain extended and non-standard headers (user-defined header attribute-value pairs)

Using headers in SIP INVITE messages, voice applications can pass information about a call to an application on another server. For example, if the caller has entered an account number and the application transfers the call to another application on another platform, the account number can be passed in a SIP Header. An example scenario is an airline application transferring the call to a hotel reservation application hosted at a different service provider. This feature enables the respective sites to share context information about the caller.

This feature introduces a new command, the **header-passing** command, to either enable or disable passing headers from INVITE messages to applications.

The SIP Header Passing feature also provides enhanced inbound and outbound dial-peer matching services.

### Feature Design of SIP SUBSCRIBE and NOTIFY for External Triggers

This feature implements support for two SIP methods, SUBSCRIBE and NOTIFY, and for a new Event header, as defined in the IETF draft, draft-roach-sip-subscribe-notify-02.txt, Event Notification in SIP.

#### Overview of the Application

The SIP event notification mechanism uses the SUBSCRIBE method to request notification of an event at a later time. The NOTIFY method provides notification that an event which has been requested by an earlier SUBSCRIBE method has occurred, or provides further details about the event. The new feature makes headers in incoming SIP INVITE, SUBSCRIBE, and NOTIFY messages available to applications for use in event



subscription. Similarly, to allow an application to place an outbound call using SIP, this feature passes headers in the URL for use by the SIP service provider interface (SPI) to create an outgoing INVITE request.

The new feature also supports the capability to subscribe to standard event packages, such as Message Waiting Indicator and Presence, and to application-specific custom event packages, as defined in SIP-Specific Event Notification, an earlier draft of RFC 3265, *Session Initiation Protocol (SIP)-Specific Event Notification*.

For information on these capabilities, see the following:

- "Cisco IOS Tcl IVR and VoiceXML Application Guide".
- "Cisco VoiceXML Programmer's Guide".
- "Tcl IVR API Version 2.0 Programming Guide".

Cisco implements the SUBSCRIBE and NOTIFY for External Triggers feature using the Application SUBSCRIBE/NOTIFY Layer (ASNL). ASNL is a software interface layer between the application and signaling protocol stacks that allows the application to subscribe to interested events and to pass notification when it is received.

The SUBSCRIBE and NOTIFY for External Triggers allows external SIP servers to trigger a particular voice application, behavior or activity on Cisco voice gateways. For example, a client application on the gateway subscribes to a particular event in a server. When the event takes place, the server notifies the client of that event. On receiving this event notification, the client application triggers a particular action in the gateway. The client and server must mutually agree on the events they can handle and the processing of those events.

### Example of a Application

The SUBSCRIBE and NOTIFY for External Triggers feature supports various applications of external triggers. In the following scenario, a user requests a stock reminder service, for example "Let me know if Stock X reaches 100. Here is a phone number to reach me." The SUBSCRIBE and NOTIFY for External Triggers feature supports an application like this in the following manner:

- The user dials into the gateway.
- The gateway sends a subscription request to the server on the user's behalf. The subscription request contains details of the event: event name, expiration time, and other information related to the event. The request can contain any application specific headers and content.
- When the server determines, through some other means, that Stock X has reached 100, it sends a notification request to the client. The SIP NOTIFY request from the server can contain any application specific headers and content.
- This notification request triggers the client on the gateway to call the specified user or destination.

Other external trigger applications include mid-call triggers such as call center queuing and subscription to a wake-up call service.

### RFC 3265 Compliance for the Feature

The Cisco implementation of SIP SUBSCRIBE and NOTIFY methods is based on an earlier draft of SIP-Specific Event Notification, and deviates from RFC 3265, *Session Initiation Protocol (SIP)-Specific Event Notification* in the following capabilities:

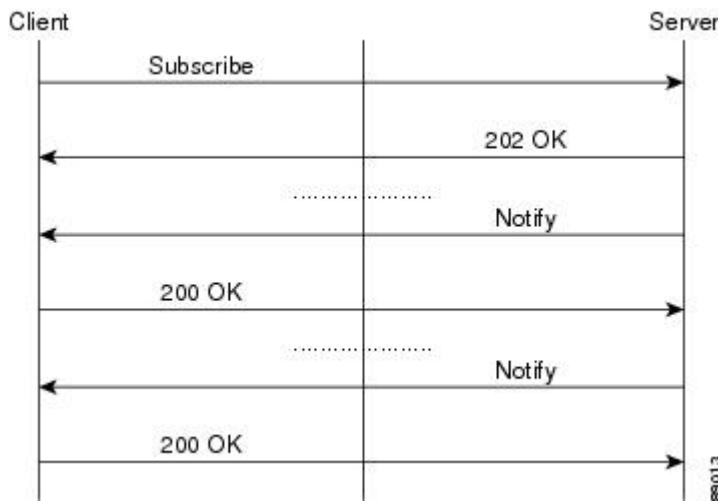
- The Cisco client does not support the following:
  - Embedded parameters in event package names.

- Subscription-State header. To terminate a subscription, the notifier or user agent sends a NOTIFY request to the Cisco gateway with the Expires header set to zero.
- Forking.
- State deltas.
- In the Cisco SIP implementation, a subscription request always creates a new dialog, and cannot send a SUBSCRIBE request for an existing dialog.
- The Cisco SIP implementation does not prevent man-in-the-middle attacks as defined in RFC 3265.
- Event package registration with the IANA is not required; instead you have the flexibility to specify your own event package.

**SUBSCRIBE and NOTIFY Message Flow**

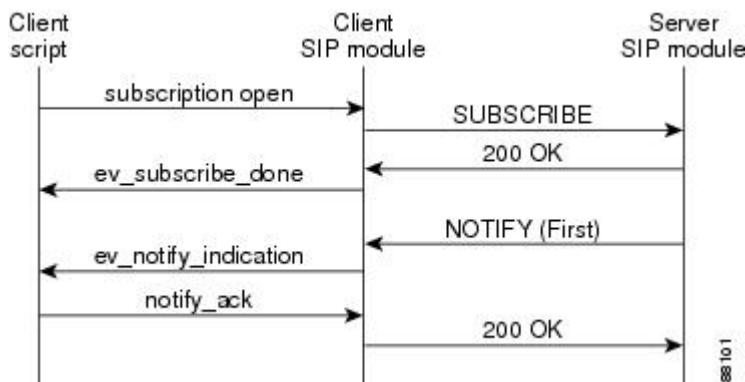
The figure below shows a typical message flow for SUBSCRIBE and NOTIFY messages.

*Figure 13: SUBSCRIBE and NOTIFY Message Flow*



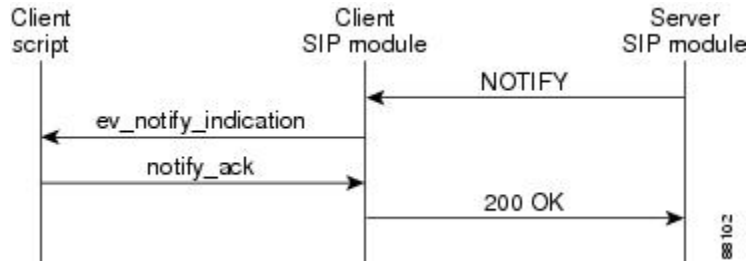
The figure below shows the message flow for a successful subscription.

*Figure 14: Successful Subscription*



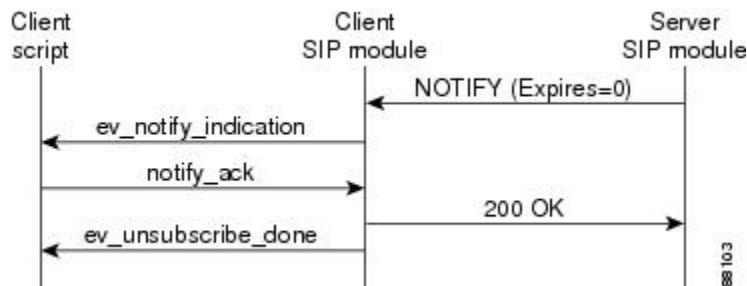
The figure below shows a completed subscription. The server can send any number of NOTIFY messages as long as the subscription is active.

**Figure 15: Subscription Completed**



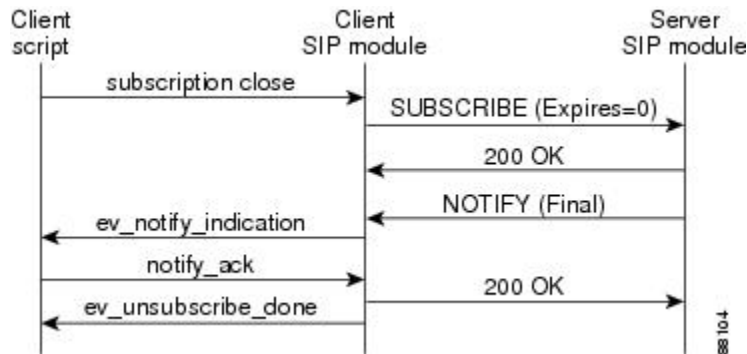
The figure below shows the message flow for subscription termination by the server.

**Figure 16: Subscription Termination by the Server**



The figure below shows the message flow for subscription termination by the client.

**Figure 17: Subscription Termination by the Client**



**Sample Messages**

This section presents a sequence of SIP messages sent and received between gateways during the message flow shown in "Sample Messages" in the preceding section.

**Example: Subscription Request Sent From Client**

This example shows a SUBSCRIBE request sent to the server. The example includes a nonstandard Subject header and an Event header.

```

*Apr 19 08:38:52.525: //-1//TCL2:HN01C24D3C:/tcl_PutsCmd:
Sending MWI client request to server
*Apr 19 08:38:52.525:
*Apr 19 08:38:52.529: Sent:
    
```

```

SUBSCRIBE sip:user@10.7.104.88:5060 SIP/2.0
Via: SIP/2.0/UDP 10.7.102.35:5060
From: <sip:10.7.102.35>;tag=1C24D44-20FD
To: <sip:user@10.7.104.88>
Date: Wed, 19 Apr 2000 08:38:52 UTC
Call-ID: C4BB7610-150411D4-802186E3-AD119804
CSeq: 101 SUBSCRIBE
Timestamp: 956133532
Subject: Hi There
Contact: <sip:10.7.102.35:5060>
Event: message-summary
Expires: 500 )
Content-Type: text/plain
Content-Length: 21
This is from client

```

### Example: Subscription Response Received from the Server

This example shows a response from the server to a subscription request.

```

*Apr 19 08:38:52.537: Received:
SIP/2.0 202 Accepted
Via: SIP/2.0/UDP 10.7.102.35:5060
From: <sip:10.7.102.35>;tag=1C24D44-20FD
To: <sip:user@10.7.104.88>;tag=1D80E90-2072
Date: Sun, 17 Nov 2002 02:59:19 GMT
Call-ID: C4BB7610-150411D4-802186E3-AD119804
Server: Cisco-SIPGateway/IOS-12.x
Timestamp: 956133532
Content-Length: 0
CSeq: 101 SUBSCRIBE
Expires: 500
*Apr 19 08:38:52.541: //-1//TCL2:HN01C24D3C:/tcl_PutsCmd: ***** act_Subscribe : SUBSCRIPTION
DONE received
*Apr 19 08:38:52.541: //-1//TCL2:HN01C24D3C:/tcl_PutsCmd: *** act_subscribe: subscription
status=sn_000

```

### Example: NOTIFY Request from the Server

This example shows the initial NOTIFY request from a server and includes an application-specific nonstandard Hello header.

```

*Apr 19 08:38:52.545: Received:
NOTIFY sip:10.7.102.35:5060 SIP/2.0
Via: SIP/2.0/UDP 10.7.104.88:5060
From: <sip:user@10.7.104.88>;tag=1D80E90-2072
To: <sip:10.7.102.35>;tag=1C24D44-20FD
Date: Sun, 17 Nov 2002 02:59:19 GMT
Call-ID: C4BB7610-150411D4-802186E3-AD119804
User-Agent: Cisco-SIPGateway/IOS-12.x
Max-Forwards: 6
Timestamp: 1037501959
CSeq: 101 NOTIFY
Event: message-summary
Hello: Hello world
Contact: <sip:user@10.7.104.88:5060>
Content-Length: 43
Content-Type: text/plain
This is content(message body) from server

```

**Example: An Application Reads Header and Body Information in a NOTIFY Request**

This example shows an application accessing the From and Hello headers in the NOTIFY request.

```
*Apr 19 08:38:52.549: //-1//TCL2:HN01C24D3C:/tcl_PutsCmd: *** act_Notify : NOTIFY RECEIVED
t
*Apr 19 08:38:52.549: //-1//TCL2:HN01C24D3C:/tcl_PutsCmd:
From header is: <sip:user@10.7.104.88>;tag=1D80E90-2072
*Apr 19 08:38:52.549: //-1//TCL2:HN01C24D3C:/tcl_PutsCmd:
Hello header is: Hello world
*Apr 19 08:38:52.549: //-1//TCL2:HN01C24D3C:/tcl_PutsCmd:
content_type received=text/plain
*Apr 19 08:38:52.549:
*Apr 19 08:38:52.553: //-1//TCL2:HN01C24D3C:/tcl_PutsCmd:
content received=This is content(message body) from server
```

**Example: NOTIFY Request Sent From the Client**

This example shows a NOTIFY request sent from a client.

```
*Apr 19 08:38:52.553: Sent:
SIP/2.0 200 OK
Via: SIP/2.0/UDP 10.7.102.35:5060
From: <sip:user@10.7.104.88>;tag=1D80E90-2072
To: <sip:10.7.102.35>;tag=1C24D44-20FD
Date: Wed, 19 Apr 2000 08:38:52 UTC
Call-ID: C4BB7610-150411D4-802186E3-AD119804
CSeq: 101 NOTIFY
Timestamp: 956133532
Event: message-summary
Content-Length: 0
```

**Example: The Client receives a NOTIFY Message**

This example shows a NOTIFY message received by a client.

```
c5300-5#
*Apr 19 08:38:57.565: Received:
NOTIFY sip:10.7.102.35:5060 SIP/2.0
Via: SIP/2.0/UDP 10.7.104.88:5060
From: <sip:user@10.7.104.88>;tag=1D80E90-2072
To: <sip:10.7.102.35>;tag=1C24D44-20FD
Date: Sun, 17 Nov 2002 02:59:19 GMT
Call-ID: C4BB7610-150411D4-802186E3-AD119804
User-Agent: Cisco-SIPGateway/IOS-12.x
Max-Forwards: 6
Timestamp: 1037501964
CSeq: 102 NOTIFY
Event: message-summary
Hello: Hello world
Contact: <sip:user@10.7.104.88:5060>
Content-Length: 35
Content-Type: text/plain
this is just a notify from server
*Apr 19 08:38:57.569: //-1//TCL2:HN01C24D3C:/tcl_PutsCmd: *** act_Notify : NOTIFY RECEIVED
*Apr 19 08:38:57.569: //-1//TCL2:HN01C24D3C:/tcl_PutsCmd:
From header is: <sip:user@10.7.104.88>;tag=1D80E90-2072
*Apr 19 08:38:57.569: //-1//TCL2:HN01C24D3C:/tcl_PutsCmd:
Hello header is: Hello world
*Apr 19 08:38:57.569: //-1//TCL2:HN01C24D3C:/tcl_PutsCmd:
content_type received=text/plain
```

```
*Apr 19 08:38:57.569: //-1//TCL2:HN01C24D3C:/tcl_PutsCmd:
content received=this is just a notify from server
```

### Example: The Client Sends a NOTIFY Message

This example shows a client sending a NOTIFY message.

```
*Apr 19 08:38:57.573: Sent:
SIP/2.0 200 OK
Via: SIP/2.0/UDP 10.7.102.35:5060
From: <sip:user@10.7.104.88>;tag=1D80E90-2072
To: <sip:10.7.102.35>;tag=1C24D44-20FD
Date: Wed, 19 Apr 2000 08:38:57 UTC
Call-ID: C4BB7610-150411D4-802186E3-AD119804
CSeq: 102 NOTIFY
Timestamp: 956133537
Event: message-summary
Content-Length: 0
```

### Example: The Client Initiates a Subscription Termination

This example shows a client initiating a subscription termination request using the Expires header set to zero.

```
*Apr 19 08:38:57.577: Sent:
SUBSCRIBE sip:user@10.7.104.88:5060 SIP/2.0
Via: SIP/2.0/UDP 10.7.102.35:5060
From: <sip:10.7.102.35>;tag=1C24D44-20FD
To: <sip:user@10.7.104.88>;tag=1D80E90-2072
Date: Wed, 19 Apr 2000 08:38:57 UTC
Call-ID: C4BB7610-150411D4-802186E3-AD119804
CSeq: 102 SUBSCRIBE
Timestamp: 956133537
Subject: Hi There
Contact: <sip:10.7.102.35:5060>
Event: message-summary
Expires: 0
Content-Type: text/plain
Content-Length: 21
This is from client
```

### Example: The Client Receives a Response to a Subscription Termination Request

This example shows a client receiving a response to a subscription termination request.

```
*Apr 19 08:38:57.589: Received:
SIP/2.0 200 OK
Via: SIP/2.0/UDP 10.7.102.35:5060
From: <sip:10.7.102.35>;tag=1C24D44-20FD
To: <sip:user@10.7.104.88>;tag=1D80E90-2072
Date: Sun, 17 Nov 2002 02:59:24 GMT
Call-ID: C4BB7610-150411D4-802186E3-AD119804
Server: Cisco-SIPGateway/IOS-12.x
Timestamp: 956133532
Content-Length: 0
CSeq: 102 SUBSCRIBE
Expires: 0
Contact: <sip:user@10.7.104.88:5060>
```

**Example: The Client Receives a Final NOTIFY Message**

This example shows a client receiving a final NOTIFY message that a subscription is finished.

```
c5300-5#
*Apr 19 08:39:02.585: Received:
NOTIFY sip:10.7.102.35:5060 SIP/2.0
Via: SIP/2.0/UDP 10.7.104.88:5060
From: <sip:user@10.7.104.88>;tag=1D80E90-2072
To: <sip:10.7.102.35>;tag=1C24D44-20FD
Date: Sun, 17 Nov 2002 02:59:24 GMT
Call-ID: C4BB7610-150411D4-802186E3-AD119804
User-Agent: Cisco-SIPGateway/IOS-12.x
Max-Forwards: 6
Timestamp: 1037501969
CSeq: 103 NOTIFY
Event: message-summary
Hello: Hello world
Contact: <sip:user@10.7.104.88:5060>
Content-Length: 35
Content-Type: text/plain
this is just a notify from server
*Apr 19 08:39:02.589: //-1//TCL2:HN01C24D3C:/tcl_PutsCmd: *** act_Notify : FINAL NOTIFY
RECEIVED
*Apr 19 08:39:02.589: //-1//TCL2:HN01C24D3C:/tcl_PutsCmd: status=sn_004
*Apr 19 08:39:02.589: //-1//TCL2:HN01C24D3C:/tcl_PutsCmd:
From header is: <sip:user@10.7.104.88>;tag=1D80E90-2072
*Apr 19 08:39:02.593: //-1//TCL2:HN01C24D3C:/tcl_PutsCmd: act_UnsubscribeDone : !!!
SUBSCRIPTION IS OVER !!!
```

**Example: A Final NOTIFY Message to a Server**

This example shows a final NOTIFY message to a server.

```
*Apr 19 08:39:02.593: Sent:
SIP/2.0 200 OK
Via: SIP/2.0/UDP 10.7.102.35:5060
From: <sip:user@10.7.104.88>;tag=1D80E90-2072
To: <sip:10.7.102.35>;tag=1C24D44-20FD
Date: Wed, 19 Apr 2000 08:39:02 UTC
Call-ID: C4BB7610-150411D4-802186E3-AD119804
CSeq: 103 NOTIFY
Timestamp: 956133542
Event: message-summary
Content-Length: 0
```

## SIP Stack Portability

The SIP Stack Portability feature implements the following capabilities to the Cisco IOS SIP gateway stack:

- It receives inbound Refer message requests both within a dialog and outside of an existing dialog from the user agents (UAs).
- It sends and receives SUBSCRIBE or NOTIFY message requests via UAs.
- It receives unsolicited NOTIFY message requests without having to subscribe to the event that was generated by the NOTIFY message request.
- It supports outbound delayed media.

It sends an INVITE message request without Session Description Protocol (SDP) and provides SDP information in either the PRACK or ACK message request for both initial call establishment and mid-call re-INVITE message requests.

- It sets SIP headers and content body in requests and responses.

The stack applies certain rules and restrictions for a subset of headers and for some content types (such as SDP) to protect the integrity of the stack's functionality and to maintain backward compatibility. When receiving SIP message requests, it reads the SIP header and any attached body without any restrictions.

To make the best use of SIP call-transfer features, you should understand the following concepts:

## SIP Call-Transfer Basics

### Basic Terminology of SIP Call Transfer

Call transfer allows a wide variety of decentralized multiparty call operations. These decentralized call operations form the basis for third-party call control, and thus are important features for VoIP and SIP. Call transfer is also critical for conference calling, where calls can transition smoothly between multiple point-to-point links and IP-level multicasting.

#### Refer Message Request

The SIP Refer message request provides call-transfer capabilities to supplement the SIP BYE and ALSO message requests already implemented on Cisco IOS SIP gateways. The Refer message request has three main roles:

- Originator--User agent that initiates the transfer or Refer request.
- Recipient--User agent that receives the Refer request and is transferred to the final-recipient.
- Final-Recipient--User agent introduced into a call with the recipient.




---

**Note** A gateway can be a recipient or final recipient, but not an originator.

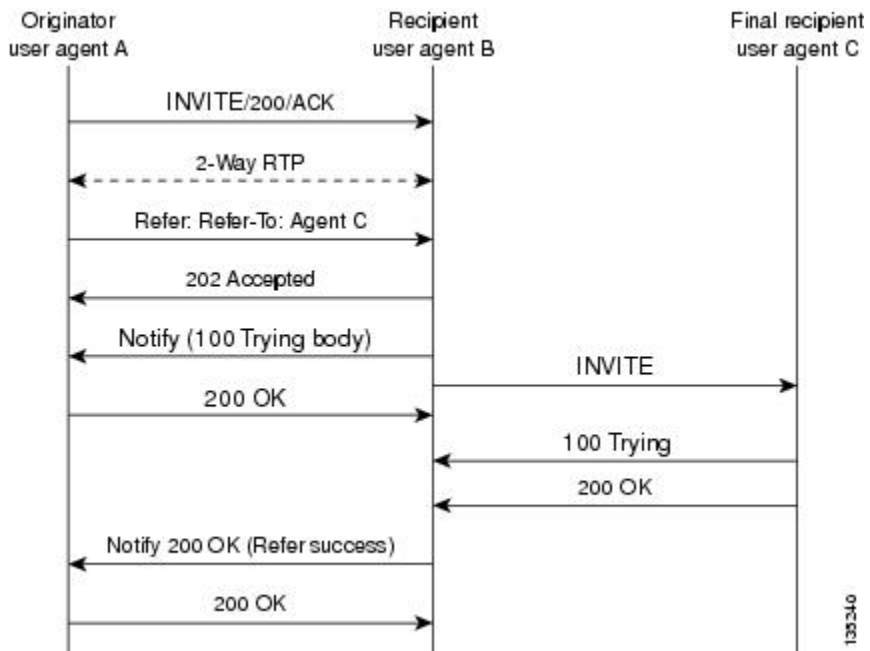
---

The Refer message request always begins within the context of an existing call and starts with the *originator*. The originator sends a Refer request to the *recipient* (user agent receiving the Refer request) to initiate a triggered INVITE request. The triggered INVITE request uses the SIP URL contained in the Refer-To header as the destination of the INVITE request. The recipient then contacts the resource in the Refer-To header (*final recipient*), and returns a SIP 202 (Accepted) response to the originator. The recipient also must notify the originator of the outcome of the Refer transaction--whether the final recipient was successfully contacted or not. The notification is accomplished using the SIP NOTIFY message request, SIP's event notification mechanism. A NOTIFY message with a message body of SIP 200 OK indicates a successful transfer, and a message body of SIP 503 Service Unavailable indicates an unsuccessful transfer. If the call was successful, a call between the recipient and the final recipient results.

The figure below represents the call flow of a successful Refer transaction initiated within the context of an existing call.



Figure 18: Successful Refer transaction



**Refer-To Header**

The recipient receives from the originator a Refer request that always contains a single Refer-To header. The Refer-To header includes a SIP URL that indicates the party to be invited and must be in SIP URL format.



**Note**

The TEL URL format cannot be used in a Refer-To header, because it does not provide a host portion, and without one, the triggered INVITE request cannot be routed.

The Refer-To header may contain three additional overloaded headers to form the triggered INVITE request. If any of these three headers are present, they are included in the triggered INVITE request. The three headers are:

- **Accept-Contact--Optional** in a Refer request. A SIP Cisco IOS gateway that receives an INVITE request with an Accept-Contact does not act upon this header. This header is defined in draft-ietf-sip-callerprefs-03.txt and may be used by user agents that support caller preferences.
- **Proxy-Authorization--Nonstandard** header that SIP gateways do not act on. It is echoed in the triggered INVITE request because proxies occasionally require it for billing purposes.
- **Replaces--Header** used by SIP gateways to indicate whether the originator of the Refer request is requesting a blind or attended transfer. It is required if the originator is performing an attended transfer, and not required for a blind transfer.

All other headers present in the Refer-To are ignored, and are not sent in the triggered INVITE.




---

**Note** The Refer-To and Contact headers are required in the Refer request. The absence of these headers results in a 4xx class response to the Refer request. Also, the Refer request must contain exactly one Refer-To header. Multiple Refer-To headers result in a 4xx class response.

---

### Referred-By Header

The Referred-By header is required in a Refer request. It identifies the originator and may also contain a signature (included for security purposes). SIP gateways echo the contents of the Referred-By header in the triggered INVITE request, but on receiving an INVITE request with this header, gateways do not act on it.




---

**Note** The Referred-By header is required in a Refer request. The absence of this header results in a 4xx class response to the Refer request. Also, the Refer request must contain exactly one Referred-By header. Multiple Referred-By headers result in a 4xx class response.

---

### NOTIFY Message Request

Once the outcome of the Refer transaction is known, the recipient of the Refer request must notify the originator of the outcome of the Refer transaction--whether the final-recipient was successfully contacted or not. The notification is accomplished using the NOTIFY message request, SIP's event notification mechanism. The notification contains a message body with a SIP response status line and the response class in the status line indicates the success or failure of the Refer transaction.

The NOTIFY message must do the following:

- Reflect the same To, From, and Call-ID headers that were received in the Refer request.
- Contain an Event header refer.
- Contain a message body with a SIP response line. For example: SIP/2.0 200 OK to report a successful Refer transaction, or SIP/2.0 503 Service Unavailable to report a failure. To report that the recipient disconnected before the transfer finished, it must use SIP/2.0 487 Request Canceled.

Two Cisco IOS commands pertain to the NOTIFY message request:

- The **timers notify** command sets the amount of time that the recipient should wait before retransmitting a NOTIFY message to the originator.
- The **retry notify** command configures the number of times a NOTIFY message is retransmitted to the originator.




---

**Note** For information on these commands, see the *Cisco IOS Voice Command Reference*.

---

## Types of SIP Call Transfer Using the Refer Message Request

This section discusses how the Refer message request facilitates call transfer.

There are two types of call transfer: blind and attended. The primary difference between the two is that the Replaces header is used in attended call transfers. The Replaces header is interpreted by the final recipient and contains a Call-ID header, indicating that the initial call leg is to be replaced with the incoming INVITE request.

As outlined in the Refer message request, there are three main roles:

- Originator--User agent that initiates the transfer or Refer request.
- Recipient--User agent that receives the Refer request and is transferred to the final recipient.
- Final-Recipient--User agent introduced into a call with the recipient.

A gateway can be a recipient or final recipient, but not an originator.

### Blind Call-Transfer Process

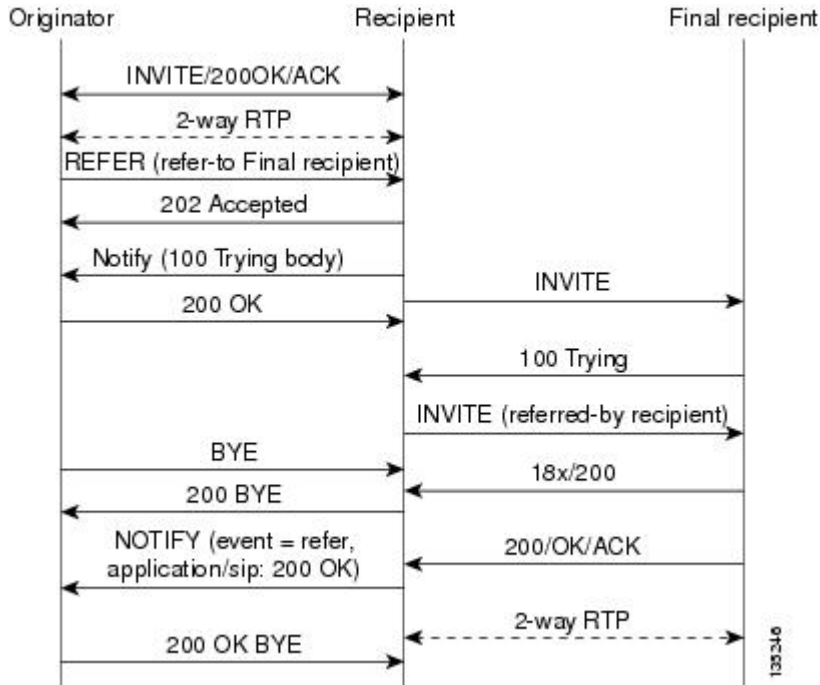
A blind, or unattended, transfer is one in which the transferring phone connects the caller to a destination line before ringback begins. This is different from a consultative, or attended, transfer in which one of the transferring parties either connects the caller to a ringing phone (ringback heard) or speaks with the third party before connecting the caller to the third party. Blind transfers are often preferred by automated devices that do not have the capability to make consultation calls.

Blind transfer works as described in the Refer Message Request section. The process is as follows:

1. Originator (user agent that initiates the transfer or Refer request) does the following:
  1. Sets up a call with recipient (user agent that receives the Refer request)
  2. Issues a Refer request to recipient
2. Recipient does the following:
  1. Sends an INVITE request to final recipient (user agent introduced into a call with the recipient)
  2. Returns a SIP 202 (Accepted) response to originator
  3. Notifies originator of the outcome of the Refer transaction--whether final recipient was successfully (SIP 200 OK) contacted or not (SIP 503 Service Unavailable)
3. If successful, a call is established between recipient and final recipient.
4. The original signaling relationship between originator and recipient terminates when either of the following occurs:
5. One of the parties sends a Bye request.
6. Recipient sends a Bye request after successful transfer (if originator does not first send a Bye request after receiving an acknowledgment for the NOTIFY message).

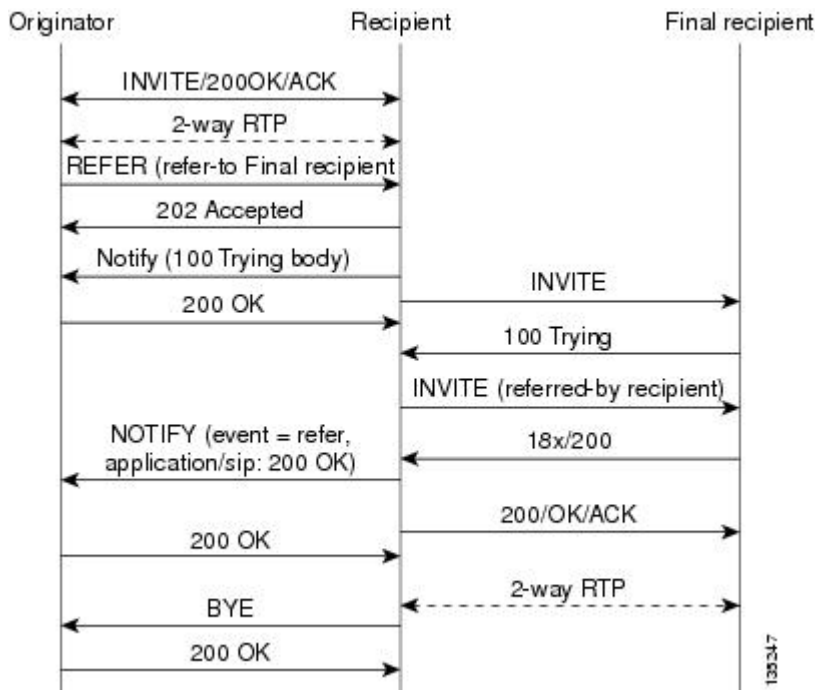
The figure below shows a successful blind or unattended call transfer in which the originator initiates a Bye request to terminate signaling with the recipient.

Figure 19: Successful Blind or Unattended Transfer--Originator Initiating a Bye Request



The figure below shows a successful blind or unattended call transfer in which the recipient initiates a Bye request to terminate signaling with the originator. A NOTIFY message is always sent by the recipient to the originator after the final outcome of the call is known.

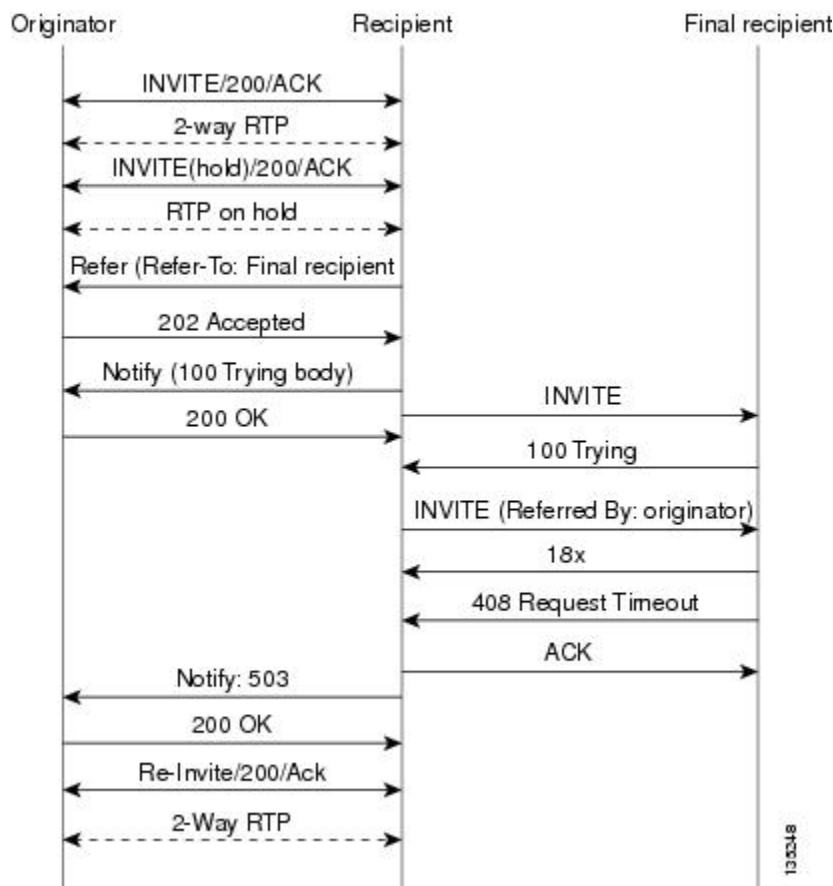
Figure 20: Successful Blind or Unattended Transfer--Recipient Initiating a Bye Request



If a failure occurs with the triggered INVITE to the final recipient, the call between originator and recipient is not disconnected. Rather, with blind transfer the process is as follows:

1. Originator sends a re-INVITE that takes the call off hold and returns to the original call with recipient.
2. Final recipient sends an 18x informational response to recipient.
3. The call fails; the originator cannot recover the call with recipient. Failure can be caused by an error condition or timeout.
4. The call leg between originator and recipient remains active (see the figure below).
5. If the INVITE to final recipient fails (408 Request Timeout), the following occurs:
  1. Recipient notifies originator of the failure with a NOTIFY message.
  2. Originator sends a re-INVITE and returns to the original call with the recipient.

**Figure 21: Failed Blind Transfer--Originator Returns to Original Call with Recipient**



**Attended Transfer**

In attended transfers, the Replaces header is inserted by the initiator of the Refer message request as an overloaded header in the Refer-To and is copied into the triggered INVITE request sent to the final recipient. The header has no effect on the recipient, but is interpreted by the final recipient as a way to distinguish between blind transfer and attended transfer. The attended transfer process is as follows:

1. Originator does the following:
  1. Sets up a call with recipient.
  2. Places recipient on hold.
  3. Establishes a call to final recipient.
  4. Sends recipient a Refer message request with an overloaded Replaces header in the Refer-To header.
2. Recipient does the following:
  1. Sends a triggered INVITE request to final recipient. (Request includes the Replaces header, identifying the call leg between the originator and the final recipient.)
  2. Recipient returns a SIP 202 (Accepted) response to originator. (Response acknowledges that the INVITE has been sent.)
3. Final recipient establishes a direct signaling relationship with recipient. (Replaces header indicates that the initial call leg is to be shut down and replaced by the incoming INVITE request.)
4. Recipient notifies originator of the outcome of the Refer transaction. (Outcome indicates whether or not the final recipient was successfully contacted.)
5. Recipient terminates the session with originator by sending a Bye request.

### Replaces Header

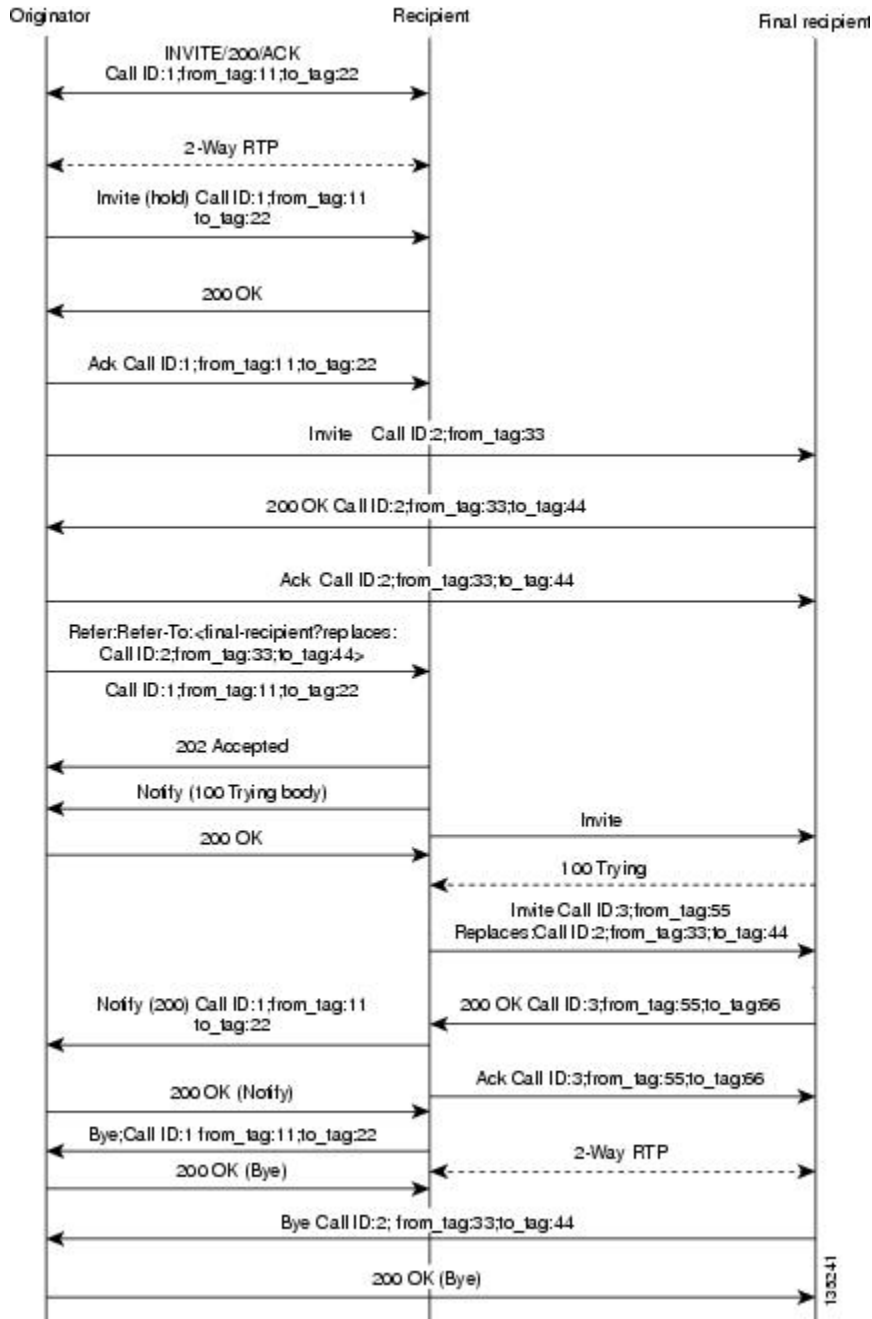
The Replaces header is required in attended transfers. It indicates to the final recipient that the initial call leg (identified by the Call-ID header and tags) is to be shut down and replaced by the incoming INVITE request. The final recipient sends a Bye request to the originator to terminate its session.

If the information provided by the Replaces header does not match an existing call leg, or if the information provided by the Replaces header matches a call leg but the call leg is not active (a Connect, 200 OK to the INVITE request has not been sent by the final-recipient), the triggered INVITE does not replace the initial call leg and the triggered INVITE request is processed normally.

Any failure resulting from the triggered INVITE request from the recipient to the final recipient does not drop the call between the originator and the final recipient. In these scenarios, all calls that are active (originator to recipient and originator to final recipient) remain active after the failed attended transfer attempt

The figure below shows a call flow for a successful attended transfer.

Figure 22: Successful Attended Transfer



**Attended Transfer with Early Completion**

Attended transfers allow the originator to have a call established between both the recipient and the final recipient. With attended transfer with early completion, the call between the originator and the final recipient does not have to be active, or in the talking state, before the originator can transfer it to the recipient. The originator establishes a call with the recipient and only needs to be setting up a call with the final recipient.

The final recipient may be ringing, but has not answered the call from the originator when it receives a re-INVITE to replace the call with the originator and the recipient.

The process for attended transfer with early completion is as follows (see the figure below):

1. Originator does the following:
  1. Sets up a call with recipient.
  2. Places the recipient on hold.
  3. Contacts the final recipient.
  4. After receiving an indication that the final recipient is ringing, sends recipient a Refer message request with an overloaded Replaces header in the Refer-To header. (The Replaces header is required in attended transfers and distinguishes between blind transfer and attended transfers.)
2. Recipient does the following:
  1. Returns a SIP 202 (Accepted) response to the originator. (to acknowledge that the INVITE has been sent.)
  2. Upon receipt of the Refer message request, sends a triggered INVITE request to final recipient. (The request includes the Replaces header, which indicates that the initial call leg, as identified by the Call-ID header and tags, is to be shut down and replaced by the incoming INVITE request.)
3. Final recipient establishes a direct signaling relationship with recipient.
4. Final recipient tries to match the Call-ID header and the To or From tag in the Replaces header of the incoming INVITE with an active call leg in its call control block. If a matching active call leg is found, final recipient replies with the same status as the found call leg. However, it then terminates the found call leg with a 487 Request Cancelled response.

**Note**

---

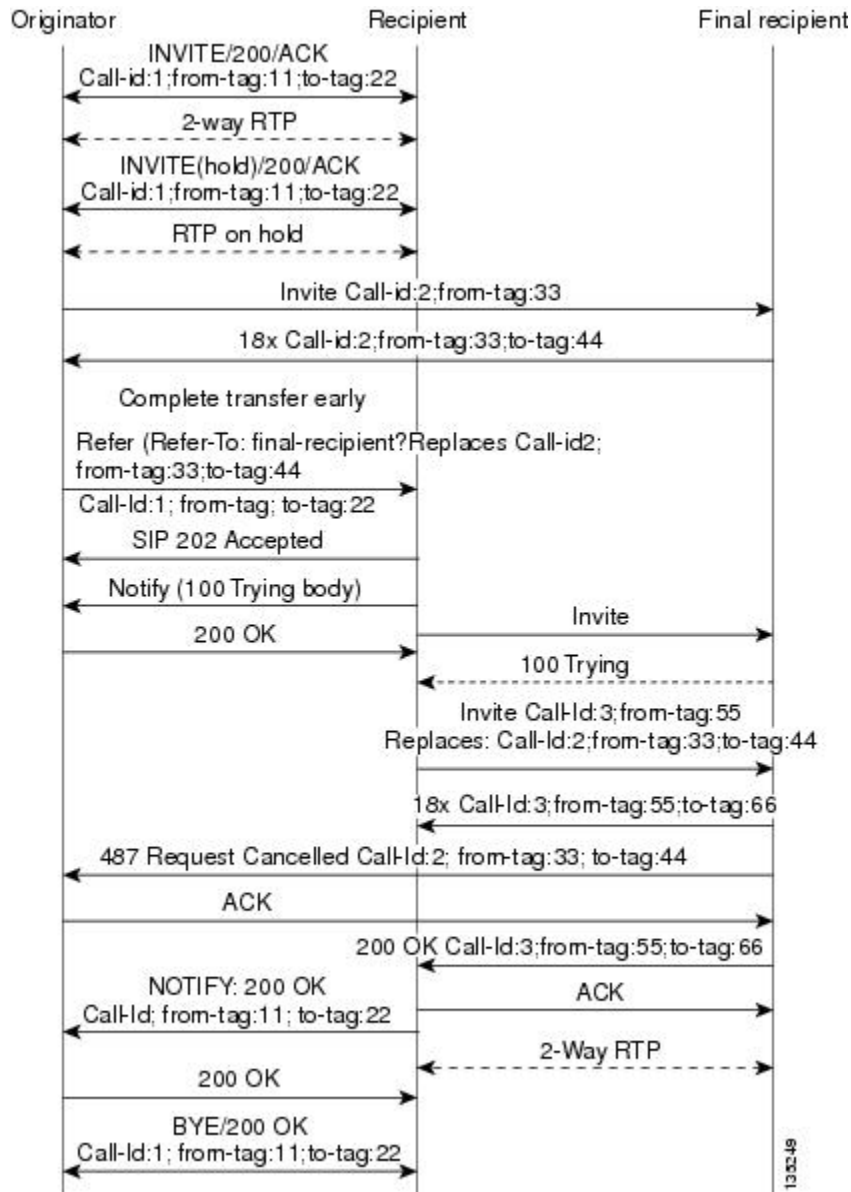
If early transfer is attempted and the call involves quality of service (QoS) or Resource Reservation Protocol (RSVP), the triggered INVITE from the recipient with the Replaces header is not processed and the transfer fails. The session between originator and final recipient remains unchanged.

---

1. Recipient notifies originator of the outcome of the Refer transaction--that is, whether final recipient was successfully contacted or not.
2. Recipient or originator terminates the session by sending a Bye request.



Figure 23: Attended Transfer with Early Completion



**VSA for Call Transfer**

You can use a vendor-specific attribute (VSA) for SIP call transfer.

**Referred-By Header**

For consistency with existing billing models, Referred-By and Requested-By headers are populated in call history tables as a VSA. Cisco VSAs are used for VoIP call authorization. The new VSA tag **supp-svc-xfer-by** helps to associate the call legs for call-detail-record (CDR) generation. The call legs can be originator-to-recipient or recipient-to-final-recipient.

The VSA tag **supp-svc-xfer-by** contains the user@host portion of the SIP URL of the Referred-By header for transfers performed with the Refer message request. For transfers performed with the Bye/Also message request, the tag contains user@host portion of the SIP URL of the Requested-By header. For each call on the gateway, two RADIUS records are generated: start and stop. The **supp-svc-xfer-by**VSA is generated only for stop records and is generated only on the recipient gateway--the gateway receiving the Refer or Bye/Also message.

The VSA is generated when a gateway that acts as a recipient receives a Refer or Bye/Also message with the Referred-By or Requested-By headers. There are usually two pairs of start and stop records. There is a start and stop record between the recipient and the originator and also between the recipient to final recipient. In the latter case, the VSA is generated between the recipient to the final recipient only.

### Business Group Field

A new business group VSA field has been added that assists service providers with billing. The field allows service providers to add a proprietary header to call records. The VSA tag for business group ID is **cust-biz-grp-id** and is generated only for stop records. It is generated when the gateway receives an initial INVITE with a vendor dial-plan header to be used in call records. In cases when the gateway acts as a recipient, the VSA is populated in the stop records between the recipient and originator and the final recipient.




---

**Note** For information on VSAs, see the *RADIUS VSA Voice Implementation Guide*.

---

## SIP Call Transfer and Call Forwarding Using Tcl IVR 2.0 and VoiceXML Applications

### SIP Call Transfer and Call Forwarding with a Tcl IVR Script

When using a Tcl IVR 2.0 application, you can implement SIP support of blind, or attended, call-transfer and call-forwarding requests from a Cisco IOS gateway. A blind transfer is one in which the transferring phone connects the caller to a destination line before ringback begins. This is different from a consultative transfer in which one of the transferring parties either connects the caller to a ringing phone (ringback heard) or speaks with the third party before connecting the caller to the third party. Blind transfers are often preferred by automated devices that do not have the capability to make consultation calls.

Before implementing blind transfer and call forwarding, you must write a custom Tcl IVR 2.0 script that implements call transfer and call forwarding. The script is responsible for receiving the hookflash event, providing dial tone, matching against the dial plan, initiating call transfer, and reestablishing the original call if the transfer attempt fails.




---

**Note** For information on writing a Tcl IVR script, see "Tcl IVR API Version 2.0 Programming Guide".

---

When the Tcl IVR script runs on the Cisco gateway, it can respond to requests to initiate blind call transfer (transfer without consultation) on a SIP call leg. SIP call forwarding on ephones (IP phones that are not configured on the gateway) is also supported.




---

**Note** SIP call transfer and call forwarding are compliant with VoiceXML. VoiceXML scripts can also be used to implement call transfer and call forwarding.

---

## Release Link Trunking on SIP Gateways

Release link trunking (RLT) functionality has been added to Cisco IOS SIP gateways. With RLT functionality, SIP call transfer now can be triggered by channel associated signaling (CAS) trunk signaling, which the custom Tcl IVR application can monitor. After a SIP call transfer has transpired and the CAS interface is no longer required, the CAS interface can be released.

The RLT functionality can be used to initiate blind transfers on SIP gateways. Blind call transfer uses the Refer message request. A full description of blind transfer and the Refer message request can be found in the “Configuring SIP Call-Transfer Features” chapter.

### RLT and SIP Call Transfers

Call transfer can be triggered by CAS trunk signaling and then captured by the Tcl IVR script on a gateway. The process begins with the originator (the SIP user agent that initiates the transfer or Refer message request) responding with a dial tone once the originator receives the signal or hookflash from the PSTN call leg. The originator then prepares to receive dual-tone multifrequency (DTMF) digits that identify the final recipient (the user agent introduced into a call with the recipient).

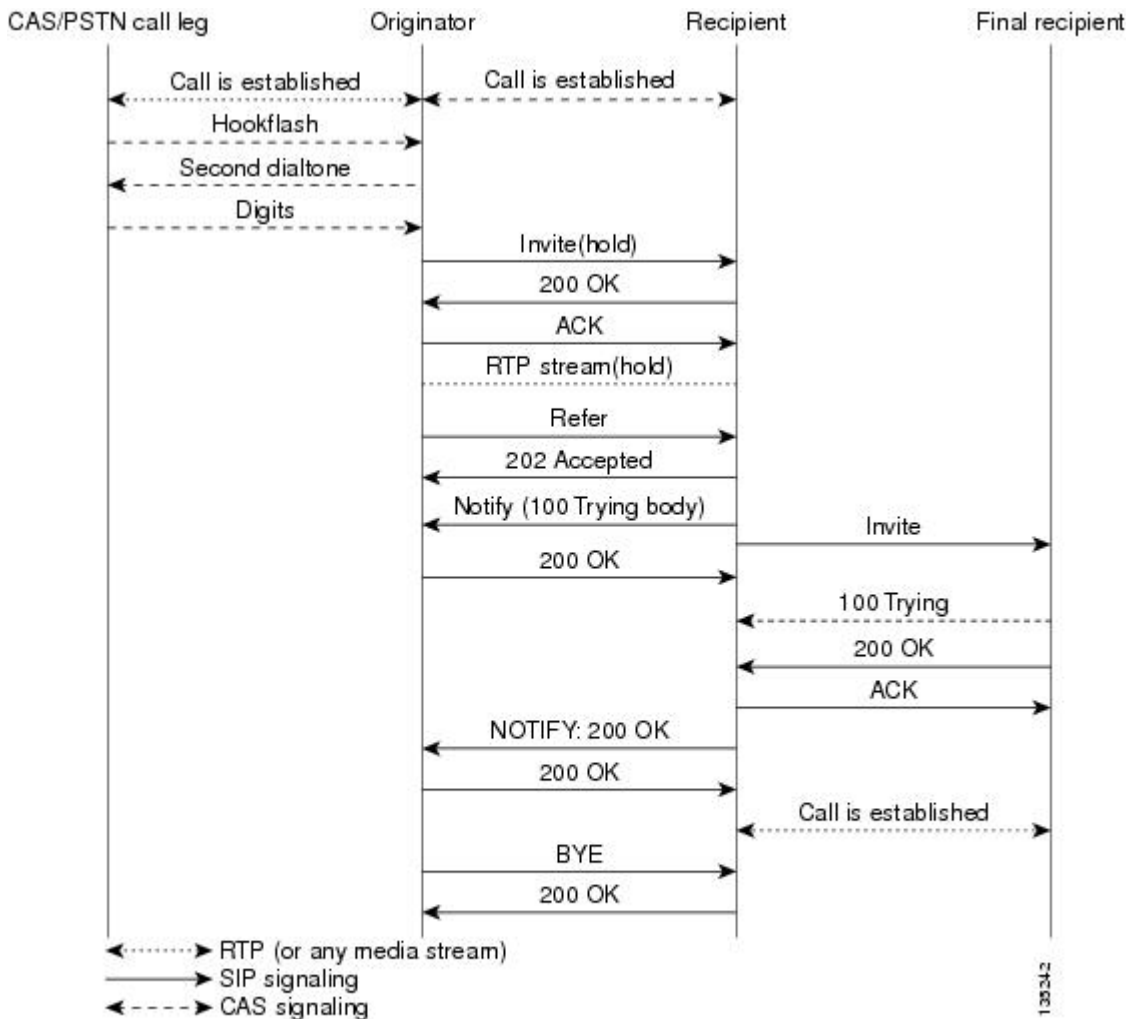
Once the first DTMF digit is received, the dial tone is discontinued. DTMF-digit collection is not completed until a 4-second interdigit timeout occurs, or an on-hook is received on that specific CAS time slot. Call transfer starts when DTMF-digit collection is successful. If digit collection fails, for example, if not enough DTMF digits or invalid digits are collected, the initial call is reestablished.

Once the DTMF digits are successfully collected, the Tcl IVR script can initiate call transfer. SIP messaging begins when the transfer is initiated with the Refer message request. The originator sends an INVITE to the recipient (the user agent that receives the Refer message request and is transferred to the final recipient) to hold the call and request that the recipient not return Real-Time Transport Protocol (RTP) packets to the originator. The originator then sends a SIP Refer message request to the recipient to start the transfer process. When the recipient receives the request, the recipient returns a 202 *Accepted* acknowledgment to the originator. The Tcl IVR script run by the originator can then release the CAS trunk and close the primary call. See the figure below.

If the recipient does not support the Refer message request, a 501 *Not implemented* message is returned. However, for backward compatibility purposes, the call transfer is automatically continued with the Bye/Also message request. The originator sends a Bye/Also request to the recipient and releases the CAS trunk with the PSTN call leg. The primary call between the originator and the recipient is closed when a 200 OK response is received.

In all other cases of call-transfer failures, the primary call between the originator and the recipient is immediately shut down.

Figure 24: Call Transfer Using the Refer Message Request



**SIP and TEL URLs in Call Transfers**

When the SIP call-transfer originator collects DTMF digits from the CAS trunk, it attempts to find a dial peer. If a dial peer is found, the session target in the dial peer is used to formulate a SIP URL. This URL can be used with both the Refer message request and the Bye/Also message request. A SIP URL is in the following form:

`sip:JohnSmith@example.com`

If a valid dial peer is not found, a Telephone Uniform Resource Locator (TEL URL) is formulated in the Refer-To header. A TEL URL is in the following form:

`tel:+11235550100`

The choice of which URL to use is critical when correctly routing SIP calls. For example, the originating gateway can send out a Bye with an Also header, but the Also header can carry only a SIP URL. The Also header cannot carry a TEL URL. That is, if the gateway decides to send a Bye/Also but cannot find a matched dial peer, the gateway reports an error on the transfer gateway and sends a Bye without the Also header.

If the recipient of a SIP call transfer is a SIP phone, the phone must have the capability to interpret either the Refer message request or the Bye/Also message request for the call transfer to work. If the recipient is a Cisco IOS gateway, there needs to be a matching dial peer for the Refer-To *user*. *User*, looking at the previous example, can be either *JohnSmith* or *11235550100*. The dial peer also needs to have an application session defined, where session can be the name of a Tcl IVR application. If there is no match, a 4xx error is sent back and no transfer occurs. If there is a POTS dial-peer match, a call is made to that POTS phone. Before Cisco IOS Release 12.2(15)T, if there is a VoIP match, the Refer-To URL is used to initiate a SIP call. In Release 12.2(15)T and later releases, the application session target in the dial peer is used for the SIP call.

### SIP Gateway Initiation of Call Transfers

SIP gateways can also initiate, or originate, attended call transfers. The process begins when the originator establishes a call with the recipient. When the user on the PSTN call leg wants to transfer the call, the user uses hookflash to get a second dial tone and then enters the final recipient's number. The Tcl IVR script can then put the original call on hold and set up the call to the final-recipient, making the originator active with the final-recipient. The Refer message request is sent out when the user hangs up to transfer the call. The Refer message request contains a Replaces header that contains three tags: *SIP CallID*, *from*, and *to*. The tags are passed along in the INVITE from the recipient to the final recipient, giving the final recipient adequate information to replace the call leg. The host portion of the Refer message request is built from the established initial call. The following is an example of a Refer message request that contains a Replaces header:

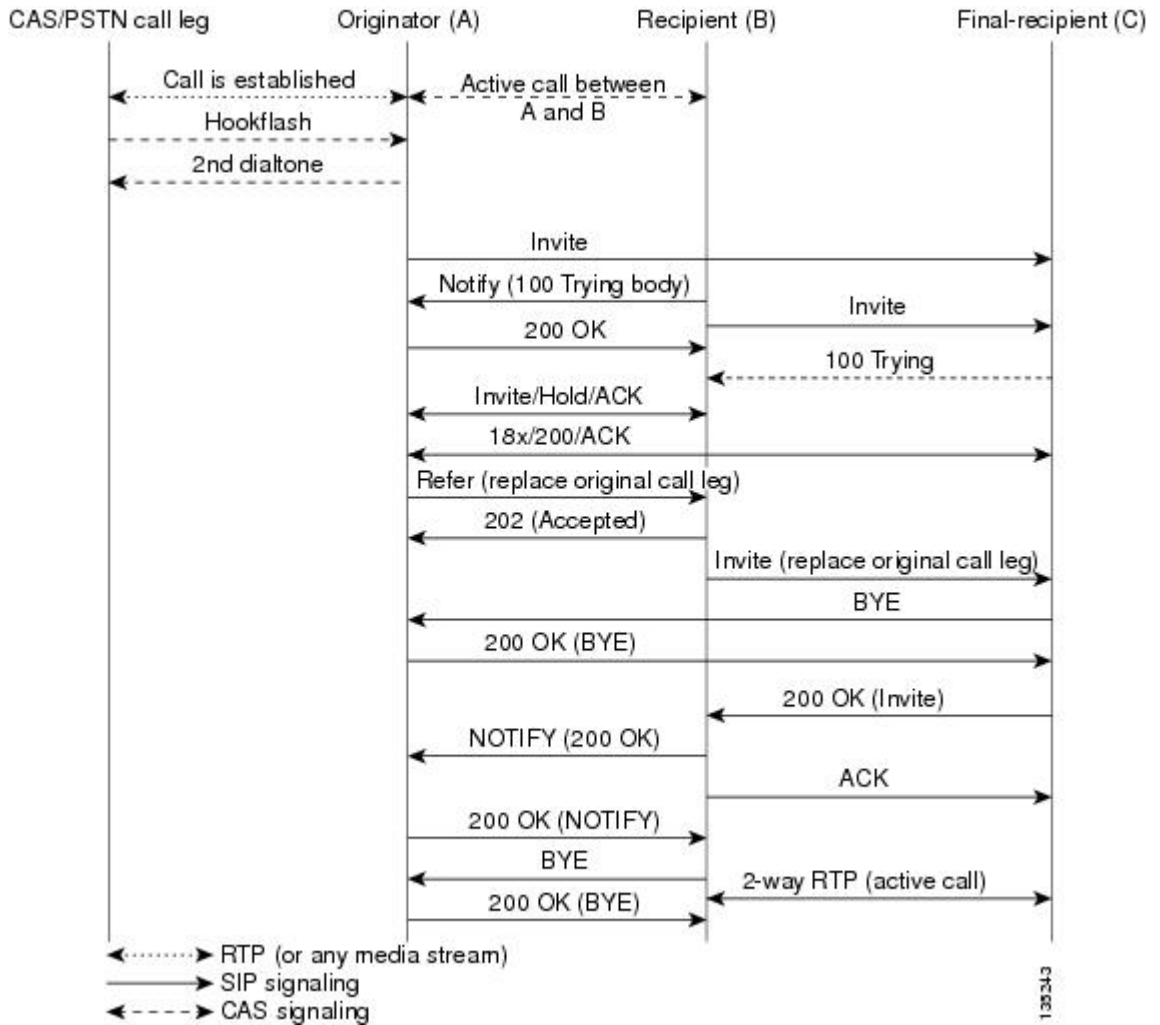


**Note** IP addresses and host names in examples are fictitious.

```
Refer sip:5550100@172.16.190.100:5060;user=phone SIP/2.0
Via: SIP/2.0/UDP 172.16.190.99:5060
From: "5550101" <sip:5555555@172.16.190.187>
To: <sip:5550100@172.16.190.187>;tag=A7C2C-1E8C
Date: Sat, 01 Jan 2000 05:15:06 GMT
Call-ID: c2943000-106ae5-1c5f-3428@172.16.197.182
User-Agent: Cisco-SIPGateway/IOS-12.x
Max-Forwards: 6
Timestamp: 946685709
CSeq: 103 Refer
Refer-To:
sip:5550101@10.102.17.217?Replaces=DD713380-339C11CC-80BCF308-92BA812C@172.16.195.77;to-tag=A5438-23E4;from-tag=C9122EDB-2408
Referred-By: <sip:5550101@172.16.190.99>
Content-Length: 0
```

Once the NOTIFY is received by the originator, the Tcl IVR script can disconnect the call between the originator and the recipient. The call between the originator and the final recipient is disconnected by the recipient sending a BYE to the originator. See the figure below for a call flow of a successful call transfer.

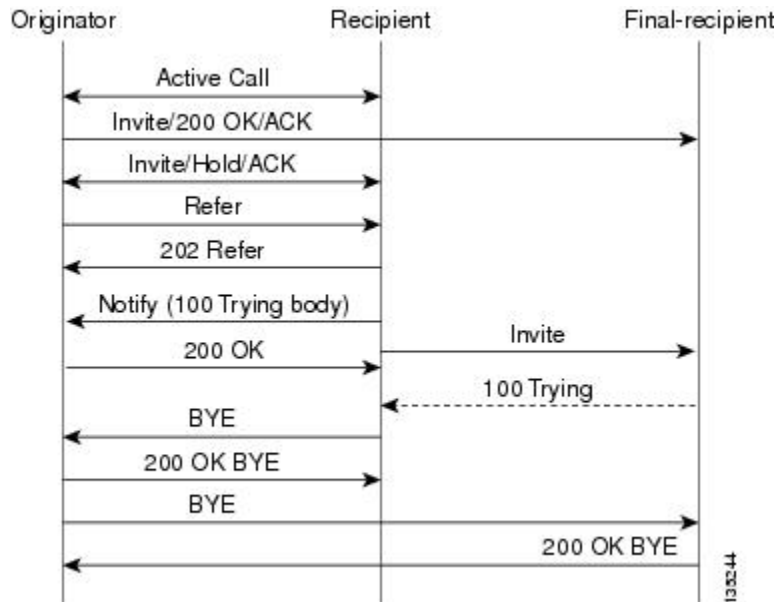
Figure 25: Successful Attended Call Transfer Initiated by the Originator



If the recipient does not support the Refer message request, a 501 *Not implemented* message is returned.

In all other cases of call-transfer failures, the primary call between the originator and the recipient is immediately shut down. The figure below shows the recipient hanging up the call before the transfer completes. The item to notice is that the NOTIFY message is never sent.

Figure 26: Unsuccessful Call Transfer--Recipient Hangs Up Before Transfer Completes



### SIP Call Forwarding

SIP call forwarding is supported only on ephones--IP phones that are not configured on the gateway. Foreign exchange station (FXS), foreign exchange office (FXO), T1, E1, and CAS phones are not supported.

With ephones, four different types of SIP call forwarding are supported:

- Call Forward Unavailable
- Call Forward No Answer
- Call Forward Busy
- Call Forward Unconditional

In all four of these call-forwarding types, a 302 *Moved Temporarily* response is sent to the user-agent client. A Diversion header included in the 302 response indicates the type of forward.

The 302 response also includes a Contact header, which is generated by the calling number that is provided by the custom Tcl IVR script. The 302 response also includes the host portion found in the dial peer for that calling number. If the calling number cannot match a VoIP dial-peer or POTS dial-peer number, a 503 *Service Unavailable* message is sent, except in the case of the Call Forward No Answer. With Call Forward No Answer, call forwarding is ignored, the phone rings, and the expires timer clears the call if there is no answer.



**Note** In Cisco IOS Release 12.2(15)T, when SIP with ephones is used, DTMF is not supported. Voice can be established, but DTMF cannot be relayed in- or out-of-band. Custom scripting is also necessary for ephones to initiate call forwarding.

## SUBSCRIBE or NOTIFY Message Request Support

The Cisco IOS gateway accepts in dialog the SUBSCRIBE message requests with the same Call-Id and tags (to and from) for out-of-band (OOB) DTMF for Event header: telephone event. There can be an ID parameter in it, but the gateway supports in-dialog subscription for only one event. After the subscription is accepted, an initial NOTIFY message request is sent and includes a Subscription-State header as per RFC 3265.

When a digit is pressed on the PSTN end, the digit event is sent in the NOTIFY message requests. The Subscription-State header in these requests is active.

When the subscription expires before it is refreshed, the gateway terminates it by sending a NOTIFY message request with a Subscription-State header value set to terminated. The subscriber can always refresh the subscription by sending another SUBSCRIBE message request with the same Call-Id and tags as in the initial SUBSCRIBE message request.

If the INVITE message request dialog is terminated before the subscription expires, the subscription is terminated by sending a NOTIFY message request with a Subscription-State header value set to terminated. The gateway does not support generating in-dialog SUBSCRIBE message request.

## SIP NOTIFY-Based Out-of-Band DTMF Relay

The Skinny Client Control Protocol (SCCP) IP phones do not support in-band DTMF digits; they are capable of sending only out-of-band DTMF digits. To support SCCP devices, originating and terminating SIP gateways can use Cisco-proprietary NOTIFY-based out-of-band DTMF relay. In addition, NOTIFY-based out-of-band DTMF relay can also be used by analog phones attached to analog voice ports (FXS) on the router.

NOTIFY-based out-of-band DTMF relay sends messages bidirectionally between the originating and terminating gateways for a DTMF event during a call. If multiple DTMF relay mechanisms are enabled on a SIP dial peer and are negotiated successfully, NOTIFY-based out-of-band DTMF relay takes precedence.

The originating gateway sends an INVITE message with a SIP Call-Info header to indicate the use of NOTIFY-based out-of-band DTMF relay. The terminating gateway acknowledges the message with an 18x or 200 Response message, also using the Call-Info header. The Call-Info header for NOTIFY-based out-of-band relay appears as follows:

```
Call-Info: <sip: address>; method="NOTIFY;Event=telephone-event;Duration=msec"
```



**Note** Duration is the interval between NOTIFY messages sent for a single digit and is set by means of the **notify telephone-event** command.

The NOTIFY-based out-of-band DTMF relay mechanism is negotiated by the SIP INVITE and 18x/200 Response messages. Then, when a DTMF event occurs, the gateway sends a SIP NOTIFY message for that event. In response, the gateway expects to receive a 200 OK message.

The NOTIFY-based out-of-band DTMF relay mechanism is similar to the DTMF message format described in RFC 2833. NOTIFY-based out-of-band DTMF relay consists of 4 bytes in a binary encoded format. The message format is shown in the figure below; the table below describes the fields.

**Figure 27: Message Format of NOTIFY-Based Out-of-Band DTMF Relay**

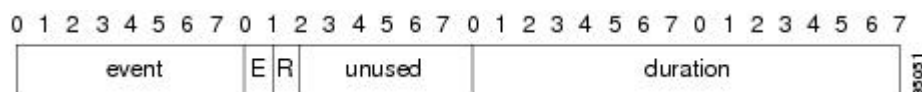




Table 8: Fields in NOTIFY-Based Out-of-Band DTMF relay Message

Field	Description
event	The DTMF event that is between 0--9, A, B, C, D, #, * and flash.
E	E signifies the end bit. If E is set to a value of 1, the NOTIFY message contains the end of the DTMF event. Thus, the duration parameter in this final NOTIFY message measures the complete duration of the event.
R	Reserved.
unused	In RFC 2833, unused corresponds to the volume field, but is not used in NOTIFY-based out-of-band DTMF relay.
duration	Duration of this DTMF event, in milliseconds.

### Sending NOTIFY Messages

As soon as the DTMF event is recognized, the gateway sends out an initial NOTIFY message for this event with the duration negotiated in the Call-Info header of the SIP INVITE. For the initial NOTIFY message, the end bit is set to zero. Afterward, one of the following actions can occur:

- If the duration of the DTMF event is less than the negotiated duration, the originating gateway sends an end NOTIFY message for this event with the duration field containing the exact duration of the event and the end bit set to 1.
- If the duration of the DTMF event is greater than the negotiated duration, the originating gateway sends another NOTIFY message for this event after the initial timer runs out. The updated NOTIFY message has a duration of twice the negotiated duration. The end bit is set to 0 because the event is not yet over. If the event lasts beyond the duration specified in the first updated NOTIFY message, another updated NOTIFY message is sent with three times the negotiated duration.
- If the duration of the DTMF event is exactly the negotiated duration, either of the preceding two actions occurs, depending on whether the end of the DTMF event occurred before or after the timer ran out.

For example, if the negotiated duration is 600 ms, as soon as a DTMF event occurs, the initial NOTIFY message is sent with duration as 600 ms. Then a timer starts for this duration.

- If the DTMF event lasts only 300 ms, the timer stops and an end NOTIFY message is sent with the duration as 300 ms.
- If the DTMF event lasts longer than 600 ms (such as 1000 ms), when the timer expires an updated NOTIFY message is sent with the duration as 1200 ms and the timer restarts. When the DTMF event ends, an end NOTIFY message is sent with the duration set to 1000 ms.

Every DTMF event corresponds to at least two NOTIFY message requests: an initial NOTIFY message and an end NOTIFY message. There might also be some update NOTIFY message requests involved, if the total duration of the event is greater than the negotiated max-duration interval. Because DTMF events generally last for less than 1000 ms, setting the duration using the **notify telephone-event** command to more than 1000 ms reduces the total number of NOTIFY messages sent. The default value of the **notify telephone-event** command is 2000 ms.

## Receiving NOTIFY Messages

Once a NOTIFY message is received by the terminating gateway, the DTMF tone plays and a timer is set for the value in the duration field. Afterward, one of the following actions can occur:

- If an end NOTIFY message for a DTMF event is received, the tone stops.
- If an update is received, the timer is updated according to the duration field.
- If an update or end NOTIFY message is not received before the timer expires, the tone stops and all subsequent NOTIFY messages for the same DTMF event or DTMF digit are ignored until an end NOTIFY message is received.
- If a NOTIFY message for a different DTMF event is received before an end NOTIFY message for the current DTMF event is received (which is an unlikely case), the current tone stops and the new tone plays. This is an unlikely case because for every DTMF event there needs to be an end NOTIFY message, and unless this is successfully sent and a 200 OK is received, the gateway cannot send other NOTIFY messages.




---

**Note** In-band tones are not passed while NOTIFY-based out-of-band DTMF relay is used as the DTMF relay message request.

---

Two commands allow you to enable or disable NOTIFY-based out-of-band DTMF relay on a dial peer. The functionality is advertised to the other end using INVITE messages if it is enabled by the commands, and must be configured on both the originating and terminating SIP gateways. A third command allows you to verify DTMF relay status:

- **dtmf-relay (VoIP)**
- **notify telephone-event**
- **show sip-ua status**

The NOTIFY message request has a Subscription-State header per RFC 3265. Refer to the “Configuring SIP DTMF Features” module for additional information that relates to the DTMF feature.

## Support for RFC 3312--QoS

This feature provides implementation on the gateway with suitable enhancements to the common stack to support quality of service (QoS) RSVP calls adhering to RFC 3312. This feature changes the existing implementation and follows RFC 3312 to provide QoS services using RSVP.

### SIP Portable Stack Considerations for QoS

The portable SIP stack is unaware of the type of call (QoS or regular). All QoS-related information carried by SIP or SDP are passed by or to the application. The application takes the necessary steps to distinguish the type of call and handle it accordingly, transparent to the portable SIP stack. From the portable SIP stack’s perspective, the call flow for establishing a QoS call is similar to that of a non-QoS call. The only additions to the portable SIP stack application for establishing or modifying QoS calls are as follows:

- Ability to send the UPDATE message request
- Support for initiating and handling 183 and PRACK message request for midcall INVITE message requests

## Behavior for QoS with RFC 3312 for Cisco IOS Gateways

The following lists the behavior that SIP QoS calls exhibits on Cisco IOS gateways, with RFC 3312 complaint stack as opposed to existing ICEE implementation:

- The QoS information is conveyed and confirmed through the following set of SDP attributes as proposed by RFC 3312.

**Current Status**--This attribute carries the current status of the network resources for a particular media stream in either offer or answer SDP. The gateways generates the following values depending on the state of the reservation.

**Desired Status**--This attribute states the preconditions for a particular media stream. For the Cisco IOS gateway the reservation is always applicable end-to-end status with resources reserved in either direction. The strength tag is configurable.

**Confirmation Status**--This attribute carries the information for the other gateway to notify back (using the UPDATE message request) once resource reservations are done on its end. On Cisco IOS gateways the originating gateways never request confirmation from the terminating gateway and if that fails, then the call is not presented and is terminated with a 580 (Precondition Failure) message response. The terminating gateway always asks for confirmation from the originating gateway when its reservations are done using the UPDATE message request. This is requested through the 183 message response for the INVITE message request.

- RFC 3312 requires the UA to use an UPDATE message request to notify the other gateway with the confirmation once the reservations are done on its end. The UPDATE message request transaction happens only if the received 183 message response contained the confirmation status attribute. The COMET message request is being used to convey that the reservations are met. With the RFC 3312 compliancy the COMET message request usage is obsolete.
- The originated INVITE message request contains the precondition option tag for use in Require and Supported header fields as in RFC 3312. With this the Content-Disposition header and Session=qos headers for QoS calls are no longer used.
- RFC 3312 suggests that the UA includes SDP (indicating QoS failure) in 580 Precondition Not Met message response. If a UAC does not make a QoS offer in the INVITE message request or gets a bad QoS offer in 18x or 2xx message response, then corresponding CANCEL or BYE message request contains an SDP body indicating QoS failure. This behavior is recommended but not mandatory as per RFC. This is kept as similar to existing implementation; 580, CANCEL, and BYE message requests continue to be sent, without SDP.
- RFC 3312 suggests the use of reliable provision responses (183/PRACK/200OK) for doing midcall QoS modifications. The current stack implementation uses the offer or answer model (Re-INVITE/200 OK/ACK) to do QoS modifications after the call is active. The new RFC recommendation for midcall does not give any advantage or extra functionality over the existing implementation. It complicates the midcall handling done by the stack. Midcall reliable provisional responses are not used by any other SIP feature, and there is no application that has an immediate need for this midcall functionality. Hence this feature continues using the existing stack's midcall INVITE offer/answer transaction for doing RSVP modifications for QoS calls.

## Backward Compatibility

The QoS call flows are not backward compatible on Cisco IOS gateways. SIP continues to use existing RSVP Cisco IOS subsystem and its APIs but the SIP or SDP signalling involved is different from the existing implementation.

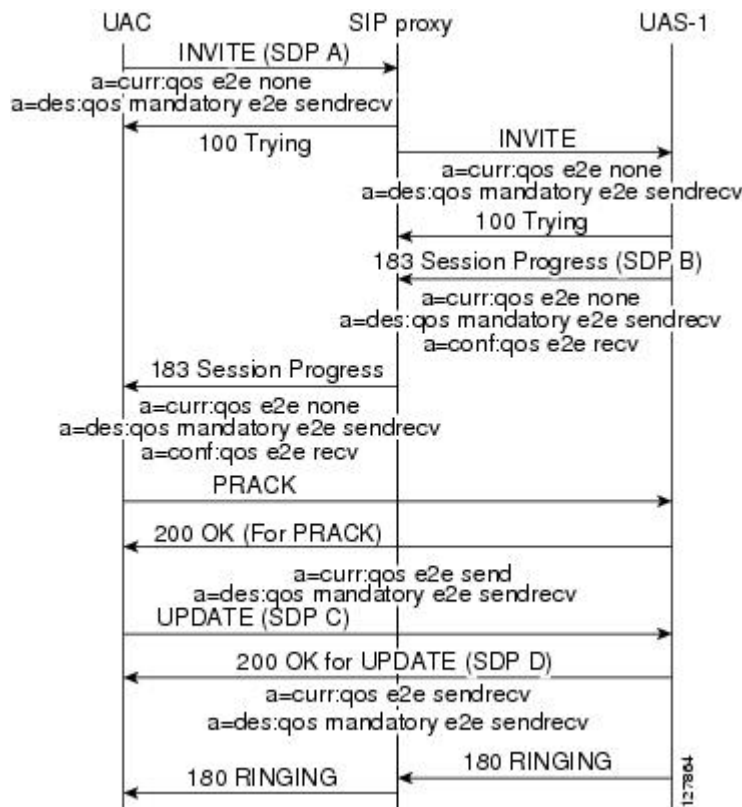
## COMET Message Request Obsolescence

This feature stack is obsolete the usage (sending or receiving) of COMET message requests. This message request is replaced by UPDATE message request. This change has minor impact on the Call Admission Control feature on Cisco IOS gateways. QoS is the only other feature to use COMET. The CAC feature is using the UPDATE message request instead of COMET.

## QoS Call Flow

The flows shown in the figure below show a two-party call that invokes RSVP services to reserve resources before the called party is alerted. On the Cisco IOS gateway for this feature implementation the originating gateway does not need confirmation for INVITE message request preconditions. All the QoS SDP attributes shown are media-level attributes. If multiple media lines are associated with their own QoS attributes, then only the first media line QoS is honored.

Figure 28: Successful QoS Call Establishment



## Support for the Achieving SIP RFC Compliance Feature

The Achieving SIP RFC Compliance feature enhances SIP gateway compliance for RFCs 3261, 3262, and 3264. This feature inherits these enhancements for the portable stack. Refer to the “Achieving SIP RFC Compliance” chapter for a description of introduced enhancements.

## Enhanced Redirect Handling

The portable stack handles redirections (3xx or 485 message responses) internally. When a 3xx or 485 class message response is received by the SIP stack, the stack sends out a new INVITE message request to the

contact in the 3xx message response, without notification to the application. In this feature, the functionality is opened up to the application. Upon receipt of a 3xx or 485 message response the application has the ability to take over the redirect response. When the application decides to handle the redirect, the SIP stack disconnects the original call that the 3xx or 485 message response received, and the application takes over responsibilities for setting up the new call.

### Cisco IOS Behavior

There are no changes in the handling of redirects in Cisco IOS software. The stack continues to perform the redirections.

## Diversion Header Draft 06 Compliance

This feature upgrades the Diversion header draft implementation to the draft-levy-diversion-06.txt version. This upgrade adds the capability to send or receive two new parameters in the Diversion header. The stack adds two new fields to set or pass this information to and from the application.




---

**Note** The draft-levy-diversion-06.txt version has since expired. Current standard uses History-Info header (refer to [RFC 4244](#) , [An Extension to the Session Initiation Protocol \(SIP\) for Request History Information](#) .

---

## SIP Domain Name Support in SIP Headers

The SIP: Domain Name Support in SIP Headers feature adds a command line interface (CLI) switch to provide a host or domain name in the host portion of the locally generated SIP headers (for example, From, RPID, and Call-ID). This feature also affects outgoing dialog-initiating SIP requests (for example, INVITE and SUBSCRIBE message requests).

To configure this feature, you should understand the following concepts:

Vendor-specific attribute (VSA) is introduced to generate information about the locally configured host or domain name in the accounting records generated by the gateway. For a complete list of VSA changes, see the RADIUS VSA Voice Implementation Guide .

## Call Active and History VoIP Records

Call active and history VoIP records present the local hostname. They have the following format:

```
#show call active voice
VOIP:
LocalHostname=example.com
```

These records are generated for calls created in the context of the INVITE message request.

## SIP Headers

The CLI affects the host portion of the following SIP headers generated for an outbound VoIP call from the SIP gateway:

- Call-ID--The Call-ID header in the SIP messages has an existing format of unique-string@ipaddr. With the CLI, the Call-ID has a value in the form of unique-string@localhostname or unique-string@domain-name. The dialog initiating the SIP requests that are affected namely are the INVITE and SUBSCRIBE message requests.

- From--The From header in the following dialog initiating requests. The INVITE and SUBSCRIBE message requests originating from the gateway have host or domain name in the host portion of the SIP URI. When the CLI is configured, the Remote-Party-ID header also has a hostname in the host portion of the SIP URI. The Remote-Party-ID header is sent out in the INVITE and INFO message requests from the gateway.

Other SIP headers such as Contact and Via are not affected by configuring the new CLI. Those headers continue to have IP addresses even when the CLI is configured.

These changes do not affect the Session Definition Protocol (SDP).

SIP headers that are provided by the application to SIP via header passing mechanisms always override headers generated by SIP.

## Sample SIP Header Messages

This section contains the following sample SIP header messages with the SIP: Domain Name Support in SIP Headers feature disabled and enabled:

### Feature Disabled--INVITE Message Request Sent from the Gateway

```
Sent:
INVITE sip:9002@example.sip.com:5060 SIP/2.0
Via:SIP/2.0/TCP 172.18.195.49;branch=z9hG4bK597
Remote-Party-ID:<sip:9001@172.18.195.49>;party=calling;screen=no;privacy=off
From:<sip:9001@172.18.195.49>;tag=3AA7574-11BA
To:<sip:9002@example.sip.com>
Date:Tue, 31 Aug 2004 13:40:57 GMT
Call-ID:3924408D-FA8A11D8-80208D32-72E3122E@172.18.195.49
Supported:100rel,timer,resource-priority
Min-SE:1800
Cisco-Guid:940277299-4203352536-2149420338-1927483950
User-Agent:Cisco-SIPGateway/IOS-12.x
Allow:INVITE, OPTIONS, BYE, CANCEL, ACK, PRACK, UPDATE, Refer , SUBSCRIBE, NOTIFY, INFO,
REGISTER
CSeq:101 INVITE
Max-Forwards:70
Timestamp:1093959657
Contact:<sip:9001@172.18.195.49:5060;transport=tcp>
Expires:180
Allow-Events:telephone-event
Content-Type:multipart/mixed;boundary=uniqueBoundary
Mime-Version:1.0
Content-Length:418
--uniqueBoundary
Content-Type:application/sdp
Content-Disposition:session;handling=required
v=0
o=CiscoSystemsSIP-GW-UserAgent 4780 5715 IN IP4 172.18.195.49
s=SIP Call
c=IN IP4 172.18.195.49
t=0 0
m=audio 18336 RTP/AVP 18 101 19
c=IN IP4 172.18.195.49
a=rtpmap:18 G729/8000
a=fmtp:18 annexb=no
a=rtpmap:101 telephone-event/8000
a=fmtp:101 0-16
a=rtpmap:19 CN/8000
```

```
a=ptime:20
--uniqueBoundary--
```

### Feature Enabled--INVITE Message Request Sent from the Gateway

```
Sent:
INVITE sip:9002@example.sip.com:5060 SIP/2.0
Via:SIP/2.0/TCP 172.18.195.49;branch=z9hG4bK22C7
Remote-Party-ID:<sip:9001@gw11.example.com>;party=calling;screen=no;privacy=off
From:<sip:9001@gw11.example.com>;tag=39CF740-FFC
To:<sip:9002@example.sip.com>
Date:Tue, 31 Aug 2004 13:26:13 GMT
Call-ID:2A101AD3-FA8811D8-801C8D32-72E3122E@gw11.example.com
Supported:100rel,timer,resource-priority
Min-SE:1800
Cisco-Guid:686218050-4203221464-2149158194-1927483950
User-Agent:Cisco-SIPGateway/IOS-12.x
Allow:INVITE, OPTIONS, BYE, CANCEL, ACK, PRACK, UPDATE, Refer , SUBSCRIBE, NOTIFY, INFO,
REGISTER
CSeq:101 INVITE
Max-Forwards:70
Timestamp:1093958773
Contact:<sip:9001@172.18.195.49:5060;transport=tcp>
Expires:180
Allow-Events:telephone-event
Content-Type:multipart/mixed;boundary=uniqueBoundary
Mime-Version:1.0
Content-Length:418
--uniqueBoundary
Content-Type:application/sdp
Content-Disposition:session;handling=required
v=0
o=CiscoSystemsSIP-GW-UserAgent 5250 7833 IN IP4 172.18.195.49
s=SIP Call
c=IN IP4 172.18.195.49
t=0 0
m=audio 18998 RTP/AVP 18 101 19
c=IN IP4 172.18.195.49
a=rtpmap:18 G729/8000
a=fmtp:18 annexb=no
a=rtpmap:101 telephone-event/8000
a=fmtp:101 0-16
a=rtpmap:19 CN/8000
a=ptime:20
--uniqueBoundary--
```

## SIP Gateway Support for SDP Session Information and Permit Hostname CLI

The SIP GW Support for SDP Session Information and Permit Hostname CLI Feature adds support to Cisco IOS SIP gateways for both SDP session information and validation of hostnames in initial INVITE requests.

### SDP Changes for Session Information Line

The SDP Session Information line can exist multiple times within a session description. The line, represented by “i=” in the SDP, can be present at the session-level as well as the media-level. You can have only one session description per packet. The session description contains one session-level, but can have multiple media-levels.

The following is a sample SDP description. The highlighted lines represent the updates to reflect RFC 2327:

```

v=0
o=mhandley 2890844526 2890842807 IN IP4 126.16.64.4
s=SDP Seminar
i=A Seminar on the session description protocol
u=http://www.cs.ucl.ac.uk/staff/M.Handley/sdp.03.ps
e=mjh@isi.edu (Mark Handley)
c=IN IP4 224.2.17.12/127
t=2873397496 2873404696
a=recvonly
m=audio 49170 RTP/AVP 0
i=media-information 1
m=video 51372 RTP/AVP 31
i=media-information 2
m=application 32416 udp wb
a=orient:portrait

```

The session information is optional, therefore internal structures are not built to expect this parameter. Specifically, internal memory is only allocated for this parameter when it is present in SDP, or when the application specifies that it be built into an outgoing message. In order to protect the internal operation of the Cisco IOS gateway, the maximum allowable length of a received session information line is 1000 characters. Session information lines over 1000 characters are truncated.

While the RFC detailing SDP indicates to only expect one session information line at the appropriate level, the Cisco IOS gateway will not “drop” the SDP in the event that this rule is violated. In the event that multiple “i=” lines are received at a particular level, the first parsed line that contains data is stored. All subsequent lines for that level are dropped.

## Validating Hostname in Initial INVITE Request URI

Beginning with Cisco IOS Software Release 12.4(9)T, administrators can validate hostnames of incoming initial INVITE messages. When the gateway processes an initial INVITE, a determination is made whether or not the host portion is in ipv4 format or a domain name.

If the host portion is an IP address, its IP address is compared with the interfaces on the gateway. If a match is found, the INVITE is processed as normal. If there is not a match, the gateway sends a **400 Bad Request - ‘Invalid IP Address’** message.

If the initial INVITE has a domain name in the host of the request URI, the gateway checks this domain name against a list of configured hostnames. If you configure no hostnames, existing behavior executes and the INVITE is processed. If you configure hostnames for this gateway, the gateway compares the host name in the request URI to the configured hostname list. If a match is found, the INVITE is processed as normal. If there is not a match, the gateway sends a **400 Bad Request - ‘Invalid host’** message.

You can configure up to 10 hostnames by re-entering the **permit hostname dns** command. Use the **no** form of this command to remove any configured hostnames.

The following example shows a configured list of hostnames. The highlighted lines represent the updates to reflect RFC 2327.

```

sip-ua
retry invite 1
registrar ipv4:172.18.193.97 expires 3600
permit hostname dns:sinise.sip.com
permit hostname dns:liotta.sip.com
permit hostname dns:sipgw.sip.com
permit hostname dns:yourgw.sip.com
permit hostname dns:csps.sip.com
!

```



The following example shows an initial INVITE message with a hostname. The highlighted line represents the updates to reflect RFC 2327.

```
INVITE sip:777@sinise.sip.com;user=phone SIP/2.0
Via: SIP/2.0/UDP 172.18.201.173:5060;branch=z9hG4bK2C419
To: <sip:777@172.18.197.154>
From: <sip:333@64.102.17.246>;tag=B87C0-B65
Date: Thu, 23 Feb 2006 16:49:26 GMT
Call-ID: 4EAF670B-A3C311DA-80148B65-6E225A8E@172.18.197.154
Contact: <sip:333@172.18.201.173>
Supported: 100rel, eatit
Allow: INVITE, OPTIONS, BYE, CANCEL, ACK, PRACK, COMET, Refer, SUBSCRIBE, NOTIFY, INFO
Max-Forwards: 70
Cseq: 104 INVITE
Expires: 60
Timestamp: 730947404
Content-Length: 211
Content-Type: application/sdp
^M
v=0
o=CiscoSystemsSIP-GW-UserAgent 6109 4520 IN IP4 172.18.201.173
s=SIP Call
c=IN IP4 111.11.111.111
t=0 0
m=audio 16880 RTP/AVP 0 19
c=IN IP4 111.11.111.111
a=rtpmap:0 PCMU/8000
a=rtpmap:19 CN/8000
a=ptime:20
```

## Outbound Proxy Support for the SIP Gateway

The Outbound Proxy Support for the SIP Gateway feature allows you to configure an outbound proxy server on a SIP gateway. You can use the **outbound-proxy** command to globally configure a SIP gateway to send all dialog initiating requests (such as INVITE, SUBSCRIBE, and REGISTER) to a specified destination. You can also use the **voice-class sip outbound-proxy** command to configure these settings on an individual dial peer, overriding the global gateway settings (refer to the *Cisco IOS Voice Command Reference*).

The request-uri of these dialog initiating requests are extracted from the session-target and does not reflect that the request is sent to a configured outbound-proxy server. The outbound-proxy server, based on the host in the request-uri, routes it accordingly. However, in some scenarios, it is possible that calls coming in over a SIP trunk to Cisco Unified CME get forwarded to the outbound SIP proxy rather than directly to the phone. To correct this behavior, use the **outbound-proxy system** command to configure SIP line-side phones on Cisco Unified CME (refer to the *Cisco Unified Communications Manager Express Command Reference*).

## SIP SIP Support for PAI

The SIP Support for PAI feature allows you to configure privacy headers into associated SIP request messages, as defined in RFC 3323 and RFC 3325. This feature introduces the **privacy and asserted-id commands which you can use to build various privacy-header requests into common SIP messages**, as shown in the table below.

Table 9: Privacy Header Request Options

Cisco IOS Command	SIP Message Header Options
privacy	ACK, BYE, CANCEL, INVITE, OPTIONS, SUBSCRIBE, NOTIFY, PRACK, IFO, and UPD
privacy pai	BYE, INVITE, OPTIONS, SUBSCRIBE, NOTIFY, and Refer
privacy ppi	BYE, INVITE, OPTIONS, SUBSCRIBE, NOTIFY, and Refer

## SIP History-info Header Support

The SIP History-info Header Support feature provides support for the history-info header in SIP INVITE messages only. The SIP gateway generates history information in the INVITE message for all forwarded and transferred calls. The history-info header records the call or dialog history. The receiving application uses the history-info header information to determine how and why the call has reached it.

The receiving application can use the call or dialog history to enhance services, such as calls to voice mail servers or sessions initiated to call centers from a click-to-talk SIP URL on a web page.

To configure the SIP History-info Header Support feature, you need to understand the following concepts:

### Feature Design of SIP History-Info Header Support

Cisco implements SIP History-Info Header Support on SIP TDM gateways and SIP-SIP Cisco UBEs by supporting the history-info header, as defined in [RFC 4244](#), [An Extension to the Session Initiation Protocol \(SIP\) for Request History Information](#). The history-info header forms part of the SIP INVITE messages that establish media sessions between user agents, and the subsequent responses to the INVITE messages.

Support for history-info headers on a gateway is enabled using the **history-info** command. The system supports multiple history-info headers (maximum of nine) for a single INVITE message. The headers are contained in a comma-separated list.

### SIP History-Info Header Support on SIP TDM Gateways

When the TDM gateway sends an INVITE message, it creates the history-info header based on the request URI.

When the gateway receives a redirected PSTN call, it builds the history-info header using the redirect information provided by the PSTN source signaling address, the local host configuration (DNS name), and the host registrar.

To maintain the correct order and to record any redirection of a request, the header includes index information (as a series of dot-delimited digits). The index format is defined in RFC 4244 section 4.3.3.1.3.

If history-info headers are enabled for the SIP stage, the gateway sends both diversion headers and history-info headers in the outbound request. However, the history-info header takes precedence when the gateway maps the header to the ISDN redirect number.



**Note** SIP-TDM gateways support the latest redirecting-number information from the ISDN leg to the peer SIP leg. They do not send multiple redirecting number-information. The History-Info header is inserted on the peer SIP leg based on the latest redirecting number.

## SIP History-Info Header Support on SIP-SIP Cisco Unified Border Element Gateways

When the Cisco UBE gateway receives an inbound INVITE message without a history-Info header, it generates the history-Info header based on the request URI of the outbound INVITE message. If privacy is enabled on the gateway, history is added to the privacy settings.

When Cisco UBE receives an outbound message, it adds the history-Info header to the message based on the request URI. Cisco UBE supports multiple history-Info headers, and history-Info headers received on the incoming SIP call leg are sent to the peer SIP leg. Cisco UBE can support up to a maximum of nine history-Info headers. If Cisco UBE receives a message with nine or more headers, it keeps only the first eight messages and adds a new header to the end of the header list.

When history-Info privacy is configured on the Cisco UBE, it transparently passes all history-Info and privacy headers in the message from one SIP stage to the next.

If history-Info headers are enabled for the SIP stage, the gateway behaves as follows:

- If no history-Info header is present, Cisco UBE converts the diversion headers to history-Info headers and sets the *cause* parameter to 302. Cisco UBE, then sends both the diversion and the history-Info headers to the next SIP stage.
- If no diversion headers are present, Cisco UBE converts all the history-Info headers with the cause parameter is set to 302 to diversion headers. Cisco UBE then sends both the diversion and history-Info headers to the next SIP stage.
- If both diversion headers and history-Info headers are present, no conversion is performed.

If history-Info headers are disabled for the SIP stage, Cisco UBE sends all diversion headers (including any new diversion headers) to the next SIP stage.

## SIP Trunk Registration

The Cisco IOS gateway registers all its POTS dial peers to the registrar when the registrar is configured on the Gateway. With the introduction of trunk registration support, registration of a single number would represent the SIP trunk. SIP trunk registration can be associated with multiple dial-peers for routing outbound calls. This registration will represent all the gateway end points for routing calls from or to the endpoints.

IOS-SIP gateway sends the REGISTER request to the configured registrar after resolving the outbound-proxy DNS name. On successful registration, IOS-SIP gateway re-uses the Outbound Proxy IP address, port number, service-route response received for sending subsequent REGISTER/INVITE.

## Support for SIP 181 Call is Being Forwarded Message

Support for SIP 181 Call is Being Forwarded message on Cisco IOS SIP TDM gateways and Cisco UBEs. This feature is enabled by default, allowing Cisco IOS SIP TDM gateways and Cisco UBEs to pass SIP 181 messages as is. To disable this feature for all SIP 181 messages or for SIP 181 messages either with or without SDP, see the **block** and **voice-class sip block** commands in the *Cisco IOS Voice Command Reference*.

On the Cisco UBE, this feature also adds the ability to receive SIP 181 messages on one leg and send out SIP 183 messages on the other leg. For details about enabling this feature on a Cisco UBE, see the **map resp-code** and **voice-class sip map resp-code** commands, also in the *Cisco IOS Voice Command Reference*.

## Support for Expires Timer Reset on Receiving or Sending SIP 183 Message

Support for resetting the Expires timer upon receipt of SIP 183 messages on Cisco Unified Communications Manager Express (Cisco Unified CME), a Cisco IOS voice gateway, or a Cisco UBE. When the terminating device lacks answer supervision or does not send the required SIP 200 OK message within the timer expiry, you can enable this feature to send periodic SIP 183 messages to reset the Expires timer and preserve the call until final response. This feature can be enabled globally or on a specific dial peer. Additionally, you can configure this feature based on the presence or absence of SDP.

For details about enabling this feature, see the **reset timer expires** and **voice-class sip reset timer expires** commands in the *Cisco IOS Voice Command Reference*.

## Support for Stripping off Progress Indication from Incoming ISDN Messages on SIP and H.323 TDM Gateways

You can use the **progress\_ind** command to configure replacement behavior on outbound dial peers on a Cisco IOS SIP or H.323 TDM voice gateway or Cisco UBE to ensure proper end-to-end signaling of VoIP calls. You can also use this command to configure removal (stripping) of PIs on outbound dial peers on Cisco IOS voice gateways or Cisco UBEs, such as when configuring a Cisco IOS SIP gateway (or SIP-SIP Cisco UBE) to not generate additional SIP 183 Session In Progress messages.

However, before configuring the **progress\_ind** command on an outbound dial peer, you must configure a destination pattern on the dial peer. To configure a destination pattern for an outbound dial peer, use the **destination-pattern** command in dial peer voice configuration mode. Once you have set a destination pattern on the dial peer, you can then use the **progress\_ind** command, also in dial peer voice configuration mode, to override and replace or remove the default progress indication (PI) in specific call message types.

For messages that contain multiple PIs, behavior configured using the **progress\_ind** command will override only the first PI in the message. Additionally, configuring a replacement PI will not result in an override of the default PI in call Progress messages if the Progress message is sent after a backward cut-through event, such as when an Alert message with a PI of 8 was sent before the Progress message.

For details about enabling this feature, see the **progress\_ind** command in the *Cisco IOS Voice Command Reference*.

## How to Configure SIP Message Timer and Response Features

**Note**

For help with a procedure, see the verification and troubleshooting sections listed above. Before you perform a procedure, familiarize yourself with the following information:

# Configuring Internal Cause Code Consistency Between SIP and H.323

## Configure Internal Cause Code Consistency Between SIP and H.323

The standard set of cause-code categories that is now generated for internal voice call failures is used by default. To configure internal failures with existing or nonstandard H.323 and SIP cause codes, perform the following steps.

### SUMMARY STEPS

1. **enable**
2. **configure terminal**
3. **voice service voip**
4. **cause-code legacy**
5. **exit**

### DETAILED STEPS

	Command or Action	Purpose
Step 1	<b>enable</b> <b>Example:</b> <pre>Router&gt; enable</pre>	Enters privileged EXEC mode or any other security level set by a system administrator. Enter your password if prompted.
Step 2	<b>configure terminal</b> <b>Example:</b> <pre>Router# configure terminal</pre>	Enters global configuration mode.
Step 3	<b>voice service voip</b> <b>Example:</b> <pre>Router(config)# voice service voip</pre>	Enters voice service VoIP configuration mode.
Step 4	<b>cause-code legacy</b> <b>Example:</b> <pre>Router(config-voi-srv)# cause-code legacy</pre>	Represents internal failures with existing or nonstandard H.323 or SIP cause codes. The keyword is as follows: <ul style="list-style-type: none"> <li>• <b>legacy</b> --Sets the internal cause code to the former and nonstandard set of values. Used for backward compatibility.</li> </ul>
Step 5	<b>exit</b> <b>Example:</b> <pre>Router(config-voi-srv)# exit</pre>	Exits the current mode.

# Configuring SIP - Configurable PSTN Cause Code Mapping

## Map PSTN Codes to SIP Status Codes

To configure incoming PSTN cause codes to SIP status codes, perform the following steps.

### SUMMARY STEPS

1. `enable`
2. `configure terminal`
3. `sip-ua`
4. `set pstn-cause value sip-status value`
5. `exit`

### DETAILED STEPS

	Command or Action	Purpose
Step 1	<b>enable</b> <b>Example:</b> <pre>Router&gt; enable</pre>	Enters privileged EXEC mode or any other security level set by a system administrator. Enter your password if prompted.
Step 2	<b>configure terminal</b> <b>Example:</b> <pre>Router# configure terminal</pre>	Enters global configuration mode.
Step 3	<b>sip-ua</b> <b>Example:</b> <pre>Router(config)# sip-ua</pre>	Enters SIP user-agent configuration mode.
Step 4	<b>set pstn-cause value sip-status value</b> <b>Example:</b> <pre>Router(config-sip-ua)# set pstn-cause 111 sip-status 400</pre>	Use this command to map an incoming PSTN cause code to a SIP error status code. Keywords and arguments are as follows: <ul style="list-style-type: none"> <li>• <b>pstn-cause value</b> --PSTN cause code. Range: 1 to 127.</li> <li>• <b>sip-status value</b> --SIP status code that is to correspond with the PSTN cause code. Range: 400 to 699.</li> </ul>
Step 5	<b>exit</b> <b>Example:</b> <pre>Router(config-sip-ua)# exit</pre>	Exits the current mode.

## Map SIP Status Codes to PSTN Cause Codes

To map incoming SIP status codes to PSTN cause codes, complete the following steps.

### SUMMARY STEPS

1. **enable**
2. **configure terminal**
3. **sip-ua**
4. **set sip-status *value* pstn-cause *value***
5. **exit**

### DETAILED STEPS

	Command or Action	Purpose
Step 1	<b>enable</b> <b>Example:</b> <pre>Router&gt; enable</pre>	Enters privileged EXEC mode or any other security level set by a system administrator. Enter your password if prompted.
Step 2	<b>configure terminal</b> <b>Example:</b> <pre>Router# configure terminal</pre>	Enters global configuration mode.
Step 3	<b>sip-ua</b> <b>Example:</b> <pre>Router(config)# sip-ua</pre>	Enters SIP user-agent configuration mode.
Step 4	<b>set sip-status <i>value</i> pstn-cause <i>value</i></b> <b>Example:</b> <pre>Router(config-sip-ua)# set sip-status 400 pstn-cause 111</pre>	Maps an incoming PSTN cause code to a SIP error status code. Keywords and arguments are as follows: <ul style="list-style-type: none"> <li>• <b>sip-status <i>value</i></b> --SIP status code that is to correspond with the PSTN cause code. Range: 400 to 699.</li> <li>• <b>pstn-cause <i>value</i></b> --PSTN cause code. Range: 1 to 127.</li> </ul>
Step 5	<b>exit</b> <b>Example:</b> <pre>Router(config-sip-ua)# exit</pre>	Exits the current mode.

## Configuring SIP Accept-Language Header Support

You can configure Accept-Language header support in two different configuration modes: voice service configuration mode and dial-peer voice configuration mode. The gateway first checks for languages configured

under the dial-peer voice configuration mode and failing a match will then default to the global voice service configuration. If no languages are configured in either mode, then the header is not added.



**Note** For the Accept-Language header to be included in the 200 OK response to an OPTIONS request, you must enable this feature in voice service configuration mode.

Perform this task to enable Accept-Language header support and specify languages carried in the Accept-Language header of SIP INVITE requests and OPTIONS responses.

## SUMMARY STEPS

1. **enable**
2. **configure terminal**
3. Do one of the following:
  - **voice service pots**
  - 
  - **dial-peer voice tag pots**
4. **supported-language language-code language-param qvalue**
5. **exit**

## DETAILED STEPS

	Command or Action	Purpose
<b>Step 1</b>	<b>enable</b> <b>Example:</b> Router> enable	Enters privileged EXEC mode, or any other security level set by a system administrator. Enter your password if prompted.
<b>Step 2</b>	<b>configure terminal</b> <b>Example:</b> Router# configure terminal	Enters global configuration mode.
<b>Step 3</b>	Do one of the following: <ul style="list-style-type: none"> <li>• <b>voice service pots</b></li> <li>•</li> <li>• <b>dial-peer voice tag pots</b></li> </ul> <b>Example:</b> Router(config)# <b>voice service pots</b> <b>Example:</b> <b>Example:</b>	Enters global voice service configuration mode or dial-peer voice configuration mode.  <b>Note</b> Voice service configuration mode configures the gateway to support the Accept-Language header in both outgoing SIP INVITE messages and OPTIONS responses. Dial-peer voice configuration mode configures it to support the header in INVITE messages only.



	Command or Action	Purpose
	<p><b>Example:</b></p> <pre>Router(config)# dial-peer voice 1 pots</pre>	
<b>Step 4</b>	<p><b>supported-language</b> <i>language-code</i> <b>language-param</b> <i>qvalue</i></p> <p><b>Example:</b></p> <pre>Router(conf-voi-serv)# supported-language EO language-param .25</pre>	<p>Specifies languages carried in the Accept-Language header in outgoing SIP INVITE messages and OPTIONS responses. Keywords and arguments are as follows:</p> <ul style="list-style-type: none"> <li>• <b>language-code</b> --Any of 139 supported languages designated by a two-letter ISO-639 country code. The note below shows a partial list of supported language codes and languages. To display a complete listing, use the help command supported-language ?</li> <li>• <b>language-param</b> <i>qvalue</i> --Priority of the language, in descending order according to the assigned parameter value. You can assign a value for each language. Range: 0, a decimal fraction in the range 0.001 to 0.999, and 1. Default: 1 (highest priority).</li> </ul>
<b>Step 5</b>	<p><b>exit</b></p> <p><b>Example:</b></p> <pre>Router(conf-voi-serv)# exit</pre>	<p>Exits the current mode.</p>

**What to do next**

The following is a partial list of supported language codes and languages. To display a complete listing, use the help command supported-language ?.

AR--Arabic	HE--Hebrew	ES--Spanish
ZH--Chinese	GA--Irish	SW--Swahili
EN--English	IT--Italian	SV--Swedish
EO--Esperanto	JA--Japanese	VI--Vietnamese
DE--German	KO--Korean	YI--Yiddish
EL--Greek	RU--Russian	ZU--Zulu

## Configuring SIP Enhanced 180 Provisional Response Handling

This feature allows you to do the following:

- Enable or disable early media cut-through treatment for SIP 180 messages with SDP
- Configure uniform call treatment for 180 messages with or without SDP



**Note** Early media cut-through for 180 messages with SDP is disabled by default; no configuration tasks are required to disable it. To re-enable the feature or to disable it after it has been re-enabled, perform the following steps.

## SUMMARY STEPS

1. **enable**
2. **configure terminal**
3. **sip-ua**
4. Do one of the following:
  - **disable-early-media 180**
  - 
  - 
  - **no disable-early-media 180**
5. **exit**

## DETAILED STEPS

	Command or Action	Purpose
<b>Step 1</b>	<b>enable</b> <b>Example:</b> Router> enable	Enters privileged EXEC mode or any other security level set by a system administrator. Enter your password if prompted.
<b>Step 2</b>	<b>configure terminal</b> <b>Example:</b> Router# configure terminal	Enters global configuration mode.
<b>Step 3</b>	<b>sip-ua</b> <b>Example:</b> Router(config)# sip-ua	Enters SIP user-agent configuration mode.
<b>Step 4</b>	Do one of the following: <ul style="list-style-type: none"> <li>• <b>disable-early-media 180</b></li> <li>•</li> <li>•</li> <li>• <b>no disable-early-media 180</b></li> </ul> <b>Example:</b> Router(config-sip-ua)# disable-early-media 180 <b>Example:</b>	Disables or (by means of <b>no</b> form of the command) reenables early media cut-through for 180 messages with SDP.

	Command or Action	Purpose
	<b>Example:</b>  <b>Example:</b> Router(config-sip-ua)# no disable-early-media 180	
<b>Step 5</b>	<b>exit</b>  <b>Example:</b> Router(config-sip-ua)# exit	Exits the current mode.

## Configuring SIP Extensions for Caller Identity and Privacy

### Configure Remote Party-ID

This feature is enabled by default; no configuration tasks are required to enable this feature. If the feature is disabled by means of the no remote-party-id command, perform this task to re-enable the feature.

#### SUMMARY STEPS

1. enable
2. configure terminal
3. sip-ua
4. remote-party-id
5. exit

#### DETAILED STEPS

	Command or Action	Purpose
<b>Step 1</b>	<b>enable</b>  <b>Example:</b> Router> enable	Enters privileged EXEC mode or any other security level set by a system administrator. Enter your password if prompted.
<b>Step 2</b>	<b>configure terminal</b>  <b>Example:</b> Router# configure terminal	Enters global configuration mode.
<b>Step 3</b>	<b>sip-ua</b>  <b>Example:</b> Router(config)# sip-ua	Enters SIP user-agent configuration mode.

	Command or Action	Purpose
<b>Step 4</b>	<b>remote-party-id</b> <b>Example:</b> <pre>Router(config-sip-ua)# remote-party-id</pre>	(Optional) Configures remote-party-id translation. The following apply: <ul style="list-style-type: none"> <li>• If a Remote-Party-ID header is present in the incoming INVITE message, the calling name and number extracted from the Remote-Party-ID header are sent as the calling name and number in the outgoing Setup message. This is the default behavior. Use the <b>remote-party-id</b> command to enable this option.</li> <li>• When no Remote-Party-ID header is available, no translation occurs so the calling name and number are extracted from the From header and are sent as the calling name and number in the outgoing Setup message. This treatment also occurs when the feature is disabled.</li> </ul>
<b>Step 5</b>	<b>exit</b> <b>Example:</b> <pre>Router(config-sip-ua)# exit</pre>	Exits the current mode.

## Configure SIP-to-PSTN Calling-Info Policy

When Remote-Party-ID support is enabled, the default calling-info treatment is the following:

- The calling name and calling number are bidirectionally translated between the display-name and the user part of the Remote-Party-ID header of the SIP INVITE message and the calling name and calling number of the PSTN Setup message.
- If a PSTN to SIP call is marked as presentation prohibited, the display-name is populated with “anonymous”. Otherwise, the display-name and user part of the From header of the outgoing INVITE are populated with the calling name and calling number.

To override the default calling-info treatment, perform this task to optionally configure SIP to PSTN calling-info policy.

### SUMMARY STEPS

1. **enable**
2. **configure terminal**
3. **sip-ua**
4. **calling-info sip-to-pstn [unscreened discard] [name set *name*] [number set *number*]**
5. **exit**

## DETAILED STEPS

	Command or Action	Purpose
Step 1	<b>enable</b> <b>Example:</b> <pre>Router&gt; enable</pre>	Enters privileged EXEC mode or any other security level set by a system administrator. Enter your password if prompted.
Step 2	<b>configure terminal</b> <b>Example:</b> <pre>Router# configure terminal</pre>	Enters global configuration mode.
Step 3	<b>sip-ua</b> <b>Example:</b> <pre>Router(config)# sip-ua</pre>	Enters SIP user-agent configuration mode.
Step 4	<b>calling-info sip-to-pstn [unscreened discard] [name set <i>name</i>] [number set <i>number</i>]</b> <b>Example:</b> <pre>Router(config-sip-ua)# calling-info sip-to-pstn unscreened discard</pre>	Specifies calling-information treatment for SIP-to-PSTN calls. Keywords and arguments are as follows: <ul style="list-style-type: none"> <li>• <b>unscreened discard</b> --Calling name and number are discarded. If the incoming SIP INVITE message does not contain a screened (;screen=yes) Remote-Party-ID header, then no name or number is sent in the forwarded Setup message.</li> <li>• <b>name set <i>name</i></b> --Calling name is unconditionally set to the <i>name</i> argument, a configured ASCII string, in the forwarded Setup message.</li> <li>• <b>number set <i>number</i></b> --Calling number is unconditional set to the <i>number</i> argument, a configured ASCII string, in the forwarded Setup message.</li> </ul>
Step 5	<b>exit</b> <b>Example:</b> <pre>Router(config-sip-ua)# exit</pre>	Exits the current mode.

## Configure PSTN-to-SIP Calling-Info Policy

To override the default calling-info treatment, perform this task to optionally configure PSTN to SIP calling-info policy.

## SUMMARY STEPS

1. **enable**
2. **configure terminal**
3. **sip-ua**

4. `calling-info pstn-to-sip [unscreened discard] [from [name set name] [number set number]] [remote-party-id [name set name] [number set number]]`
5. `exit`

## DETAILED STEPS

	Command or Action	Purpose
Step 1	<p><b>enable</b></p> <p><b>Example:</b></p> <pre>Router&gt; enable</pre>	Enters privileged EXEC mode or any other security level set by a system administrator. Enter your password if prompted.
Step 2	<p><b>configure terminal</b></p> <p><b>Example:</b></p> <pre>Router# configure terminal</pre>	Enters global configuration mode.
Step 3	<p><b>sip-ua</b></p> <p><b>Example:</b></p> <pre>Router(config)# sip-ua</pre>	Enters SIP user-agent configuration mode.
Step 4	<p><b>calling-info pstn-to-sip [unscreened discard] [from [name set <i>name</i>] [number set <i>number</i>]] [remote-party-id [name set <i>name</i>] [number set <i>number</i>]]</b></p> <p><b>Example:</b></p> <pre>Router(config-sip-ua)# calling-info pstn-to-sip unscreened discard</pre>	<p>Specifies calling-information treatment for PSTN-to-SIP calls. Keywords and arguments are as follows:</p> <ul style="list-style-type: none"> <li>• <b>unscreened discard</b> --Calling name and number are discarded. Unless the screening indicator in the incoming Setup is marked as “user-provided, passed screening” or “network-provided,” no calling name or number is sent in the forwarded INVITE message.</li> <li>• <b>from name set <i>name</i></b> --Display name of the From header is unconditionally set to the <i>name</i> argument, a configured ASCII string, in the forwarded INVITE message.</li> <li>• <b>from number set <i>number</i></b> --User part of the From header is unconditionally set to the <i>number</i> argument, a configured ASCII string, in the forwarded INVITE message.</li> <li>• <b>remote-part-id name set <i>name</i></b> --Display name of the Remote-Party-ID header is unconditionally set to the <i>name</i> argument, a configured ASCII string, in the forwarded INVITE message.</li> <li>• <b>remote-party-id number set <i>number</i></b> --User part of the Remote-Party-ID header is unconditionally set to the <i>number</i> argument, a configured ASCII string, in the forwarded INVITE message.</li> </ul>

	Command or Action	Purpose
Step 5	<b>exit</b> <b>Example:</b> <pre>Router(config-sip-ua)# exit</pre>	Exits the current mode.

## Configuring SIP INVITE Request with Malformed Via Header

There are no configuration steps for this feature. Use the **show sip-ua statistics** command (see "Verifying SIP Message Components Session Timers and Responses Configuration") to display the Bad Request counter.

## Configuring Privacy Headers

You can configure privacy headers according to values defined in RFC 3323 and RFC 3325 as shown in the table below.

*Table 10: Privacy Header Values*

Header Value	Description
Header	Indicates that the privacy service enforces privacy for all headers in the SIP message which might identify information about the subscriber.
Session	Indicates that the information held in the session description protocol (SDP) is hidden outside the trusted domain.
User	Enforces user-level privacy for the subscriber by removing any user identification from the SIP message.
Critical	Indicates that the message is rejected if the privacy service cannot or will not enforce the specified privacy.  <b>Note</b> You can only add critical to privacy headers if you also choose a privacy header for user, header, session, or ID.
ID	Indicates the Network-Asserted Identity remains private with respect to SIP entries outside the user-authenticated trusted domain.
PSTN	Indicates information passed in from the PSTN Octet 3a of the CALLING PARTY Information Element enables privacy information on the VoIP side of the call (see the Privacy Header PSTN with UAC Gateway section).
System	Use system settings.
Disable	Disables the privacy.

## UAC Gateway Behavior

When you configure the **privacy** command to use one of the header values shown in the table above, then the gateway's outgoing message request contains a privacy header set to the corresponding privacy value. The

following example shows the format of the “From” header, if you configure the **privacy** command, based on RFC 3323:

```
From: "Anonymous" <sip:anonymous@anonymous.invalid>; tag=<tag value>
```

If you configure the **privacy critical** command, the gateway adds a Proxy-Require header with the value set to critical. Thus, in the unlikely event that the user agent sends a request to an intermediary that does not support the described extension, the request will fail.

If you configure the **asserted-id pa** command, the gateway builds a PAI into the common SIP stack. The **asserted-id pa** command has priority over the Remote-Party-ID (RPID) header and removes this header from any outbound message even if the router is configured to use the RPID header.

If you configure the **asserted-id ppi** command, the gateway builds a PPI into the common SIP stack. The **asserted-id ppi** command has priority over the Remote-Party-ID (RPID) header and removes this header from any outbound message even if the router is configured to use the RPID header.

## Privacy Header PSTN with UAC Gateway

You can use the **privacy pstn** command to derive information passed in from the PSTN Octet 3a of the CALLING PARTY Information Element to enable privacy information on the VoIP side of the call. The data within the CALLING PARTY field indicates whether or not you want to relay calling information. The CALLING PARTY field also supplies information and details about who supplied the information, and whether or not the information has been verified.

The table below summarizes the relationship between the ISDN Octet 3a values and the SIP-header values that the UAC gateway generates, when you configure the **privacy pstn** command.

**Table 11: ISDN Octet 3a-to-SIP Header Mapping for UAC Gateways**

ISDN Octet 3a	SIP Headers			
Presentation Status Bit(5)	Number Origin Bits(0,1)	From	Asserted-ID	Privacy
Presentation allowed.	User provided, number not screened.	No change.	PPI.	Not included.
Presentation allowed.	User provided, number passed, and network screened.	No change.	PAI.	Not included.
Presentation allowed.	User provided, number failed, and network screened.	No change.	PPI.	Not included.
Presentation	Network-provided number.	No change.	PAI.	Not included.
Presentation prohibited.	User provided, number not screened (00).	Anonymous.	P-Preferred Identity.	ID.
Presentation prohibited.	User provided, number passed, and network screened (01).	Anonymous.	P-Asserted Identity.	ID.
Presentation prohibited.	Network provided number (11).	Anonymous.	P-Asserted Identity.	ID.



## Interaction with Caller ID When Privacy Exists

When you configure the **privacy pstn** command, on the UAC gateway side of the call, after configuring the **substitute name** command under the **clid (voice-service-voip)** command and defining no “Display Name” parameter, then the PAI or PPI substitutes the calling number in the Display field.

The following example show a PAI header when the **substitute name** command is not set:

```
P-Asserted_Identity: <sip:5551212@example.com>
```

If you set the **substitute name** command, the header in the example is modified:

```
P-Asserted_Identity: "5551212" <sip:5551212@example.com>
```

When you configure the **privacy pstn** command, after configuring the **strip pi-restrict all** command under the **clid (voice-service-voip)** command, and if the CALLING INFORMATION Octet 3a indicates that the number is restricted, then the PAI/PPI value is not sent.

On the UAS gateway side of the call, if you configure the **clid network-provided** command, it will override any value you set by using the **privacy** command. If you configure the **clid network-provided** command and a PPI is received, the number in the Octet 3a is set to “Network Provided.” If you do not configure the **clid network-provided** command, the number in the Octet 3a is set to “User Provided.”

If you configure the **calling-info pstn-to-sip unscreened discard** command and the **privacy pstn** command, and if the calling number has a screening indicator of “User-provided, not screened,” or “User-provided, failed screen” the PAI/PPI is not sent.

The table below summarizes the interaction when you configure the **privacy pstn** command.

**Table 12: Interactions When Using the privacy pstn Command**

Presentation Indication	Screening Indication	calling-info pstn-to-sip Command	Generated Headers
See the SIP: SIP Support for PAI section.	See the SIP: SIP Support for PAI section.	Not set.	If you do not configure the <b>calling-info pstn-to-sip</b> command, then see the SIP: SIP Support for PAI section.
Presentation allowed.	User provided, not screened.	Unscreened discard.	From: <sip:example.com>; tag=1 Contact: <sip:example.com>
Presentation allowed.	User provided number passed network screening.	Unscreened discard.	From: <sip:5551212@example.com>; tag=1 Contact: <sip:5551212@example.com:5060> P-Asserted-Identity: <sip:5551212@example.com>
Presentation allowed.	User provided number failed network screening.	Unscreened discard.	From: <sip:example.com>; tag=1 Contact: <sip:example.com>

Presentation Indication	Screening Indication	calling-info pstn-to-sip Command	Generated Headers
Presentation prohibited.	User provided number, not screened.	Unscreened discard.	From: "Anonymous" <sip:anonymous@anonymous.com>; tag=1 Contact: <sip:example.com> Privacy: ID
Presentation prohibited	User provided number, failed network screening.	Unscreened discard	From: "Anonymous" <sip:anonymous@anonymous.com>; tag=1 Contact: <sip:example.com> Privacy: ID
Presentation prohibited	User provided number, passed network screening.	Unscreened discard	From: "Anonymous" <sip:anonymous@anonymous.com>; tag=1 P-Asserted-Identity: Contact: <sip:5551212@example.com:> Privacy: ID
Presentation prohibited	Network-provided number	Unscreened discard	

## Configuring SIP Session Timer Support

To configure SIP session timer support including the Min-SE value, perform the following steps.

### SUMMARY STEPS

1. **enable**
2. **configure terminal**
3. **voice service voip**
4. **sip**
5. **min-se time**
6. **exit**

### DETAILED STEPS

	Command or Action	Purpose
<b>Step 1</b>	<b>enable</b> <b>Example:</b>  Router> enable	Enters privileged EXEC mode or any other security level set by a system administrator. Enter your password if prompted.
<b>Step 2</b>	<b>configure terminal</b> <b>Example:</b>  Router# configure terminal	Enters global configuration mode.

	Command or Action	Purpose
Step 3	<b>voice service voip</b> <b>Example:</b> <pre>Router(config)# voice service voip</pre>	Enters voice service VoIP configuration mode.
Step 4	<b>sip</b> <b>Example:</b> <pre>Router(conf-voi-serv)# sip</pre>	Enters SIP configuration mode.
Step 5	<b>min-se time</b> <b>Example:</b> <pre>Router(conf-serv-ua)# min-se 90</pre>	Changes the minimum-session-expiration header value for all calls that use the SIP session timer support feature. The argument is as follows: <ul style="list-style-type: none"> <li>• <i>time</i> --Time, in seconds. Range: 60 to 86400 (one day). Default: 90 (1.5 minutes).</li> </ul>
Step 6	<b>exit</b> <b>Example:</b> <pre>Router(conf-serv-ua)# exit</pre>	Exits the current mode.

## Configuring SIP Cisco IOS Gateway Reason Header and Buffered Calling Name Completion

The SIP: Cisco IOS Gateway Reason Header and Buffered Calling Name Completion feature implements support for Reason headers and buffered calling-name completion. Reason-header support on Cisco IOS gateways is defined by RFC 3326.

Feature benefits include the following:

- Reason-header support facilitates PSTN internetworking by providing a more deterministic method of transporting the actual PSTN disconnect cause code to a remote PSTN gateway.
- Buffered calling-name completion (such as buffered-invite timers) makes the process of receiving ISDN-display information in a subsequent ISDN FACILITY message transparent to the remote SIP endpoint.
- The requirement of an external SIP user-agent server (UAS) to support INFO message responses before the call is active is removed.

### Configure Reason-Header Override

#### SUMMARY STEPS

1. **enable**
2. **configure terminal**
3. **sip-ua**

4. `reason-header override`
5. `exit`

#### DETAILED STEPS

	Command or Action	Purpose
<b>Step 1</b>	<b>enable</b> <b>Example:</b> <code>Router&gt; enable</code>	Enters privileged EXEC mode or any other security level set by a system administrator. Enter your password if prompted.
<b>Step 2</b>	<b>configure terminal</b> <b>Example:</b> <code>Router# configure terminal</code>	Enters global configuration mode.
<b>Step 3</b>	<b>sip-ua</b> <b>Example:</b> <code>Router(config)# sip-ua</code>	Enters SIP user-agent configuration mode.
<b>Step 4</b>	<b>reason-header override</b> <b>Example:</b> <code>Router(config-sip-ua)# reason-header override</code>	Enables Reason-header override support.
<b>Step 5</b>	<b>exit</b> <b>Example:</b> <code>Router(config-sip-ua)# exit</code>	Exits the current mode.

## Configure Buffer Calling-Name Completion

#### SUMMARY STEPS

1. `enable`
2. `configure terminal`
3. `sip-ua`
4. `timers buffer-invite timer`
5. `exit`

## DETAILED STEPS

	Command or Action	Purpose
Step 1	<b>enable</b> <b>Example:</b> <pre>Router&gt; enable</pre>	Enters privileged EXEC mode or any other security level set by a system administrator. Enter your password if prompted.
Step 2	<b>configure terminal</b> <b>Example:</b> <pre>Router# configure terminal</pre>	Enters global configuration mode.
Step 3	<b>sip-ua</b> <b>Example:</b> <pre>Router(config)# sip-ua</pre>	Enters SIP-user-agent configuration mode.
Step 4	<b>timers buffer-invite timer</b> <b>Example:</b> <pre>Router(config-sip-ua)# timers buffer-invite 500</pre>	Enables the SIP buffer-invite timer and sets the timer interval. The argument is as follows: <ul style="list-style-type: none"> <li><i>timer</i> --Buffer-invite timer value, in ms. Range: 50 to 5000.</li> </ul>
Step 5	<b>exit</b> <b>Example:</b> <pre>Router(config-sip-ua)# exit</pre>	Exits the current mode.

## Configuring SIP SIP Header URL Support and SUBSCRIBE NOTIFY for External Triggers

### Configure SIP Header Support

## SUMMARY STEPS

1. **enable**
2. **configure terminal**
3. **voice service voip**
4. **sip**
5. **header-passing**
6. **exit**

## DETAILED STEPS

	Command or Action	Purpose
<b>Step 1</b>	<b>enable</b> <b>Example:</b>  Router> Enable	Enables privileged EXEC mode. Enter your password if prompted.
<b>Step 2</b>	<b>configure terminal</b> <b>Example:</b>  Router# configure terminal	Enters global configuration mode.
<b>Step 3</b>	<b>voice service voip</b> <b>Example:</b>  Router(config)# voice service voip	Enters voice service VoIP configuration mode.
<b>Step 4</b>	<b>sip</b> <b>Example:</b>  Router(conf-voi-serv)# sip	Enters SIP configuration mode.
<b>Step 5</b>	<b>header-passing</b> <b>Example:</b>  Router(conf-serv-sip)# header-passing	Enables or disables SIP header-passing to applications. When the gateway receives SIP INVITE, SUBSCRIBE, and NOTIFY messages, this command enables passing SIP headers associated with these messages to the target application in the gateway.
<b>Step 6</b>	<b>exit</b> <b>Example:</b>  Router(conf-serv-sip)# exit	Exits the current mode.

## Configure SIP SUBSCRIBE and NOTIFY for External Triggers

To configure SIP subscription options, perform the following steps.

**Before you begin**

- Enable SIP header passing.

## SUMMARY STEPS

1. **enable**
2. **configure terminal**
3. **voice service voip**
4. **sip**
5. **subscription asnl session history [duration *minutes*] [count *number*]**

6. **subscription maximum originate** *number*
7. **exit**
8. **sip-ua**
9. **retry subscribe** *number*
10. **exit**

## DETAILED STEPS

	Command or Action	Purpose
<b>Step 1</b>	<b>enable</b> <b>Example:</b> <pre>Router&gt; enable</pre>	Enables privileged EXEC mode. Enter your password if prompted.
<b>Step 2</b>	<b>configure terminal</b> <b>Example:</b> <pre>Router# configure terminal</pre>	Enters global configuration mode.
<b>Step 3</b>	<b>voice service voip</b> <b>Example:</b> <pre>Router(config)# voice service voip</pre>	Enters voice service VoIP configuration mode.
<b>Step 4</b>	<b>sip</b> <b>Example:</b> <pre>Router(conf-voi-serv)# sip</pre>	Enters SIP configuration mode.
<b>Step 5</b>	<b>subscription asnl session history</b> [ <i>duration minutes</i> ] [ <i>count number</i> ] <b>Example:</b> <pre>Router(conf-serv-sip)# subscription asnl session history duration 10 count 100</pre>	(Optional) Specifies how long to keep Application SUBSCRIBE/NOTIFY Layer (ASNL) subscription history records and how many records to keep in memory.
<b>Step 6</b>	<b>subscription maximum originate</b> <i>number</i> <b>Example:</b> <pre>Router(conf-serv-sip)# subscription maximum originate 10</pre>	(Optional) Specifies the maximum number of outstanding subscriptions to be originated by the gateway, up to two times the maximum number of dial peers on the platform. Default is the maximum number of dial peers on the platform.
<b>Step 7</b>	<b>exit</b> <b>Example:</b> <pre>Router(conf-serv-sip)# exit</pre>	Exits the current mode.

	Command or Action	Purpose
<b>Step 8</b>	<b>sip-ua</b> <b>Example:</b> <pre>Router(config)# sip-ua</pre>	Enters SIP user-agent configuration mode.
<b>Step 9</b>	<b>retry subscribe <i>number</i></b> <b>Example:</b> <pre>Router(config-sip-ua)# retry subscribe 10</pre>	(Optional) Sets the number of times that a SIP SUBSCRIBE message is resent to the other user agent.
<b>Step 10</b>	<b>exit</b> <b>Example:</b> <pre>Router(config-sip-ua)# exit</pre>	Exits the current mode.

## Configuring SIP Stack Portability

No configuration tasks are required to configure the SIP stack portability feature. The feature is enabled by default.

## Configuring SIP Domain Name Support in SIP Headers

### Configure the Hostname in Locally Generated SIP Headers

You can configure the hostname in either of two configuration modes:



**Note** Dial-peer-specific configuration takes precedence over more general gateway-wide configuration.

#### Gateway-Wide Configuration Mode

This procedure allows global configuration of the local hostname for use for locally generated URIs.

#### SUMMARY STEPS

1. **enable**
2. **configure terminal**
3. **voice service voip**
4. **sip**
5. **localhost dns:local-host-name-string**
6. **exit**



## DETAILED STEPS

	Command or Action	Purpose
Step 1	<b>enable</b> <b>Example:</b>  Router> enable	Enables privileged EXEC mode. Enter your password if prompted.
Step 2	<b>configure terminal</b> <b>Example:</b>  Router# configure terminal	Enters global configuration mode.
Step 3	<b>voice service voip</b> <b>Example:</b>  Router(config)# voice service voip	Enters voice service VoIP configuration mode.
Step 4	<b>sip</b> <b>Example:</b>  Router(config-voip-serv)# sip	Enters SIP configuration mode.
Step 5	<b>localhost dns:local-host-name-string</b> <b>Example:</b>  Router(config-serv-sip)# localhost dns:example.com	Enters a local hostname string.
Step 6	<b>exit</b> <b>Example:</b>  Router(config-serv-sip)# exit	Exits the current mode.

## Dial-Peer-Specific Configuration Mode

This procedure allows dial-peer configuration of the local hostname for use for locally generated URIs.



**Note** This procedure takes precedence over more general gateway-wide configuration.

## SUMMARY STEPS

1. enable
2. configure terminal
3. dial-peer voice tag voip
4. voice-class sip localhost [dns]:local host-name-string
5. exit

## DETAILED STEPS

	Command or Action	Purpose
<b>Step 1</b>	<b>enable</b> <b>Example:</b>  Router> enable	Enables privileged EXEC mode. Enter your password if prompted.
<b>Step 2</b>	<b>configure terminal</b> <b>Example:</b>  Router# configure terminal	Enters global configuration mode.
<b>Step 3</b>	<b>dial-peer voice tag voip</b> <b>Example:</b>  Router# dial-peer voice 100 voip	Enters dial-peer configuration mode for the specified dial peer.
<b>Step 4</b>	<b>voice-class sip localhost [dns]:local host-name-string</b> <b>Example:</b>  Router(config-dial-peer)# voice-class sip localhost dns:example.com	Enters a local hostname string.
<b>Step 5</b>	<b>exit</b> <b>Example:</b>  Router(config-dial-peer)# exit	Exits the current mode.

## Monitor the Hostname in Locally Generated SIP Headers

This procedure monitors the gateway-wide or dial-peer-specific configuration.

## SUMMARY STEPS

1. enable
2. show call active voice
3. show call history voice
4. exit

## DETAILED STEPS

	Command or Action	Purpose
<b>Step 1</b>	<b>enable</b> <b>Example:</b>  Router> enable	Enables privileged EXEC mode. Enter your password if prompted.

	Command or Action	Purpose
Step 2	<b>show call active voice</b> <b>Example:</b> Router# show call active voice	Displays call information for voice calls in progress.
Step 3	<b>show call history voice</b> <b>Example:</b> Router# show call history voice	Displays the call history table for voice calls.
Step 4	<b>exit</b> <b>Example:</b> Router# exit	Exits the current mode.

### Examples

This section provides the following command output:

#### show call active Command Output: Example

The following example shows active-call command output when the local hostname is enabled.

```
Router# show call active voice
```

```
Telephony call-legs:1
SIP call-legs:1
H323 call-legs:0
Call agent controlled call-legs:0
Multicast call-legs:0
Total call-legs:2
```

```

GENERIC:
SetupTime=126640 ms
Index=1
PeerAddress=9001
PeerSubAddress=
PeerId=100
PeerIfIndex=6
LogicalIfIndex=4
ConnectTime=130300 ms
CallDuration=00:00:47 sec
CallState=4
CallOrigin=2
ChargedUnits=0
InfoType=speech
TransmitPackets=2431
TransmitBytes=48620
ReceivePackets=2431
ReceiveBytes=48620
TELE:

```

## Examples

```

ConnectionId=[0xA0DC41CF 0x115511D9 0x8002EC82 0xAB4FD5BE]
IncomingConnectionId=[0xA0DC41CF 0x115511D9 0x8002EC82 0xAB4FD5BE]
CallID=1
TxDuration=48620 ms

VoiceTxDuration=48620 ms
FaxTxDuration=0 ms
CoderTypeRate=g729r8
NoiseLevel=-61
ACOMLevel=3
OutSignalLevel=-35
InSignalLevel=-30
InfoActivity=2
ERLLevel=3
SessionTarget=
ImgPages=0
CallerName=
CallerIDBlocked=False
OriginalCallingNumber=
OriginalCallingOctet=0x0
OriginalCalledNumber=
OriginalCalledOctet=0x80
OriginalRedirectCalledNumber=
OriginalRedirectCalledOctet=0x0
TranslatedCallingNumber=9001
TranslatedCallingOctet=0x0
TranslatedCalledNumber=
TranslatedCalledOctet=0x80
TranslatedRedirectCalledNumber=
TranslatedRedirectCalledOctet=0x0
GwCollectedCalledNumber=9002
GENERIC:
SetupTime=128980 ms
Index=1
PeerAddress=9002
PeerSubAddress=
PeerId=3301
PeerIfIndex=7
LogicalIfIndex=0
ConnectTime=130300 ms
CallDuration=00:00:50 sec
CallState=4
CallOrigin=1
ChargedUnits=0
InfoType=speech
TransmitPackets=2587
TransmitBytes=51740
ReceivePackets=2587
ReceiveBytes=51740
VOIP:
ConnectionId[0xA0DC41CF 0x115511D9 0x8002EC82 0xAB4FD5BE]
IncomingConnectionId[0xA0DC41CF 0x115511D9 0x8002EC82 0xAB4FD5BE]
CallID=2
RemoteIPAddress=172.18.193.87
RemoteUDPPort=17602
RemoteSignallingIPAddress=172.18.193.87
RemoteSignallingPort=5060
RemoteMediaIPAddress=172.18.193.87
RemoteMediaPort=17602
RoundTripDelay=2 ms
SelectedQoS=best-effort
tx_DtmfRelay=inband-voice

```

```
FastConnect=FALSE
AnnexE=FALSE
Separate H245 Connection=FALSE
H245 Tunneling=FALSE
SessionProtocol=sipv2
ProtocolCallId=A240B4DC-115511D9-8005EC82-AB4FD5BE@pip.example.com
SessionTarget=172.18.193.87
OnTimeRvPlayout=48620
GapFillWithSilence=0 ms
GapFillWithPrediction=0 ms
GapFillWithInterpolation=0 ms
GapFillWithRedundancy=0 ms
HiWaterPlayoutDelay=70 ms
LoWaterPlayoutDelay=69 ms
TxPakNumber=2434
TxSignalPak=0
TxComfortNoisePak=0
TxDuration=48680
TxVoiceDuration=48680
RxPakNumber=2434
RxSignalPak=0
RxDuration=0
TxVoiceDuration=48670
VoiceRxDuration=48620
RxOutOfSeq=0
RxLatePak=0
RxEarlyPak=0
PlayDelayCurrent=69
PlayDelayMin=69
PlayDelayMax=70
PlayDelayClockOffset=43547
PlayDelayJitter=0
PlayErrPredictive=0
PlayErrInterpolative=0
PlayErrSilence=0
PlayErrBufferOverflow=0
PlayErrRetroactive=0
PlayErrTalkspurt=0
OutSignalLevel=-35
InSignalLevel=-30
LevelTxPowerMean=0
LevelRxPowerMean=-302
LevelBgNoise=0
ERLLevel=3
ACOMLevel=3
ErrRxDrop=0
ErrTxDrop=0
ErrTxControl=0
ErrRxControl=0
ReceiveDelay=69 ms
LostPackets=0
EarlyPackets=0
LatePackets=0
SRTP = off
VAD = enabled
CoderTypeRate=g729r8
CodecBytes=20
Media Setting=flow-around
CallerName=
CallerIDBlocked=False
OriginalCallingNumber=9001
OriginalCallingOctet=0x0
OriginalCalledNumber=9002
OriginalCalledOctet=0x80
```

```

OriginalRedirectCalledNumber=
OriginalRedirectCalledOctet=0x0
TranslatedCallingNumber=9001
TranslatedCallingOctet=0x0
TranslatedCalledNumber=9002
TranslatedCalledOctet=0x80
TranslatedRedirectCalledNumber=
TranslatedRedirectCalledOctet=0x0
GwCollectedCalledNumber=9002
GwOutpulsedCalledNumber=9002
GwOutpulsedCalledOctet3=0x80
GwOutpulsedCallingNumber=9001
GwOutpulsedCallingOctet3=0x0
GwOutpulsedCallingOctet3a=0x0
MediaInactiveDetected=no
MediaInactiveTimestamp=
MediaControlReceived=
Username=
LocalHostname=pip.example.com ! LocalHostname field
Telephony call-legs:1
SIP call-legs:1
H323 call-legs:0
Call agent controlled call-legs:0
Multicast call-legs:0
Total call-legs:2

```

### show call history Command Output: Example

The following example shows call-history command output when the local hostname is enabled.

```

Router# show call history voice
Telephony call-legs:1
SIP call-legs:1
H323 call-legs:0
Call agent controlled call-legs:0
Total call-legs:2
GENERIC:
SetupTime=128980 ms
Index=1
PeerAddress=9002
PeerSubAddress=
PeerId=3301
PeerIfIndex=7
LogicalIfIndex=0
DisconnectCause=10
DisconnectText=normal call clearing (16)
ConnectTime=130300 ms
DisconnectTime=329120 ms
CallDuration=00:03:18 sec
CallOrigin=1
ReleaseSource=4
ChargedUnits=0
InfoType=speech
TransmitPackets=9981
TransmitBytes=199601
ReceivePackets=9987
ReceiveBytes=199692
VOIP:
ConnectionId[0xA0DC41CF 0x115511D9 0x8002EC82 0xAB4FD5BE]
IncomingConnectionId[0xA0DC41CF 0x115511D9 0x8002EC82 0xAB4FD5BE]
CallID=2
RemoteIPAddress=172.18.193.87
RemoteUDPPort=17602

```

```
RemoteSignallingIPAddress=172.18.193.87
RemoteSignallingPort=5060
RemoteMediaIPAddress=172.18.193.87
RemoteMediaPort=17602
SRTP = off
RoundTripDelay=1 ms
SelectedQoS=best-effort
tx_DtmfRelay=inband-voice
FastConnect=FALSE
AnnexE=FALSE
Separate H245 Connection=FALSE
H245 Tunneling=FALSE
SessionProtocol=sipv2
ProtocolCallId=A240B4DC-115511D9-8005EC82-AB4FD5BE@pip.example.com
SessionTarget=172.18.193.87
OnTimeRvPlayout=195880
GapFillWithSilence=0 ms
GapFillWithPrediction=0 ms
GapFillWithInterpolation=0 ms
GapFillWithRedundancy=0 ms
HiWaterPlayoutDelay=70 ms
LoWaterPlayoutDelay=69 ms
ReceiveDelay=69 ms
LostPackets=0
EarlyPackets=0
LatePackets=0
VAD = enabled
CoderTypeRate=g729r8
CodecBytes=20
cvVoIPCallHistoryIcpif=2
MediaSetting=flow-around
CallerName=
CallerIDBlocked=False
OriginalCallingNumber=9001
OriginalCallingOctet=0x0
OriginalCalledNumber=9002
OriginalCalledOctet=0x80
OriginalRedirectCalledNumber=
OriginalRedirectCalledOctet=0x0
TranslatedCallingNumber=9001
TranslatedCallingOctet=0x0
TranslatedCalledNumber=9002
TranslatedCalledOctet=0x80
TranslatedRedirectCalledNumber=
TranslatedRedirectCalledOctet=0x0
GwCollectedCalledNumber=9002
GwOutpulsedCalledNumber=9002
GwOutpulsedCalledOctet3=0x80
GwOutpulsedCallingNumber=9001
GwOutpulsedCallingOctet3=0x0
GwOutpulsedCallingOctet3a=0x0
MediaInactiveDetected=no
MediaInactiveTimestamp=
MediaControlReceived=
LocalHostname=pip.example.com ! LocalHostname field
Username=
GENERIC:
SetupTime=126640 ms
Index=2
PeerAddress=9001
PeerSubAddress=
PeerId=100
PeerIfIndex=6
LogicalIfIndex=4
```

```

DisconnectCause=10
DisconnectText=normal call clearing (16)
ConnectTime=130300 ms
DisconnectTime=330080 ms
CallDuration=00:03:19 sec
CallOrigin=2
ReleaseSource=4
ChargedUnits=0
InfoType=speech
TransmitPackets=9987
TransmitBytes=199692
ReceivePackets=9981
ReceiveBytes=199601
TELE:
ConnectionId=[0xA0DC41CF 0x115511D9 0x8002EC82 0xAB4FD5BE]
IncomingConnectionId=[0xA0DC41CF 0x115511D9 0x8002EC82 0xAB4FD5BE]
CallID=1
TxDuration=195940 ms
VoiceTxDuration=195940 ms
FaxTxDuration=0 ms
CoderTypeRate=g729r8
NoiseLevel=-73
ACOMLevel=4
SessionTarget=
ImgPages=0
CallerName=
CallerIDBlocked=False
OriginalCallingNumber=
OriginalCallingOctet=0x0
OriginalCalledNumber=
OriginalCalledOctet=0x80
OriginalRedirectCalledNumber=
OriginalRedirectCalledOctet=0x0
TranslatedCallingNumber=9001
TranslatedCallingOctet=0x0
TranslatedCalledNumber=
TranslatedCalledOctet=0x80
TranslatedRedirectCalledNumber=
TranslatedRedirectCalledOctet=0x0
GwCollectedCalledNumber=9002

```

## Configuring SIP Gateway Support for Session Information

There are no tasks for configuring SIP gateway support for session information.

## Configuring SIP Gateway Support for Permit Hostname CLI

To configure a list of hostname to validate against incoming INVITE messages, perform the following steps.




---

**Note** Hostname can be a maximum of 30 characters; hostnames longer than 30 characters are truncated.

---

>

---

### SUMMARY STEPS

1. enable



2. `configure terminal`
3. `sip-ua`
4. `permit hostname dns: <domain name>`
5. `exit`

#### DETAILED STEPS

	Command or Action	Purpose
Step 1	<b>enable</b> <b>Example:</b> <pre>Router&gt; enable</pre>	Enables privileged EXEC mode. <ul style="list-style-type: none"> <li>• Enter your password if prompted.</li> </ul>
Step 2	<b>configure terminal</b> <b>Example:</b> <pre>Router# configure terminal</pre>	Enters global configuration mode.
Step 3	<b>sip-ua</b> <b>Example:</b> <pre>Router (config)# sip-ua</pre>	Enters SIP user-agent configuration mode.
Step 4	<b>permit hostname dns: &lt;domain name&gt;</b> <b>Example:</b> <pre>Router (config-sip-ua)# permit hostname dns:sip.example.com</pre>	Validates a hostname of initial incoming INVITE messages. The argument is: <ul style="list-style-type: none"> <li>• <i>domain name</i>-- Domain name in DNS format. Domain names can be up to 30 characters in length; those domain names exceeding 30 characters are truncated.</li> </ul>
Step 5	<b>exit</b> <b>Example:</b> <pre>Router (config-sip-ua)# exit</pre>	Exits the current mode.

## Configuring Outbound Proxy Support for the SIP Gateway

### Configuring an Outbound-Proxy Server Globally on a Gateway

To configure SIP support for an outbound-proxy server globally on a SIP gateway, follow these steps:

#### SUMMARY STEPS

1. `enable`
2. `configure terminal`
3. `voice service {pots | voatm | vofr | voip}`
4. `sip`

5. `outbound-proxy < ipv4:A:B:C:D: port/dns:host.domain>`
6. `exit`

### DETAILED STEPS

	Command or Action	Purpose
<b>Step 1</b>	<b>enable</b> <b>Example:</b> <pre>Router&gt; enable</pre>	Enables privileged EXEC mode. <ul style="list-style-type: none"> <li>• Enter your password if prompted.</li> </ul>
<b>Step 2</b>	<b>configure terminal</b> <b>Example:</b> <pre>Router# configure terminal</pre>	Enters global configuration mode.
<b>Step 3</b>	<b>voice service {pots   voatm   vofr   voip}</b> <b>Example:</b> <pre>Router(config)# voice service voip</pre>	Enters voice service VoIP configuration mode and specifies the voice encapsulation.
<b>Step 4</b>	<b>sip</b> <b>Example:</b> <pre>Router(conf-voi-ser)# sip</pre>	Enters SIP configuration mode.
<b>Step 5</b>	<b>outbound-proxy &lt; ipv4:A:B:C:D: port/dns:host.domain&gt;</b> <b>Example:</b> <pre>Router(conf-ser-sip)# outbound-proxy dns:sipprefix.example.com</pre>	Configures an outbound proxy server. This example shows how to configure an outbound-proxy server to a SIP proxy server in the domain example.com.
<b>Step 6</b>	<b>exit</b> <b>Example:</b> <pre>Router (conf-ser-sip)# exit</pre>	Exits the current mode.

## Configuring an Outbound-Proxy Server on a Dial Peer

### SUMMARY STEPS

1. `enable`
2. `configure terminal`
3. `dial-peer voice tag {pots | vofr | voip}`
4. `voice-class sip`
5. `sip`
6. `outbound-proxy {ipv4:ip-address[:port-number] | dns:host:domain}`

## 7. exit

## DETAILED STEPS

	Command or Action	Purpose
Step 1	<b>enable</b> <b>Example:</b> Router> enable	Enables privileged EXEC mode. <ul style="list-style-type: none"><li>• Enter your password if prompted.</li></ul>
Step 2	<b>configure terminal</b> <b>Example:</b> Router# configure terminal	Enters global configuration mode.
Step 3	<b>dial-peer voice tag {pots   vofr   voip}</b> <b>Example:</b> Router(conf)# dial-peer voice 111 voip	Define a particular dial peer, specifies the method of voice encapsulation, and enters dial-peer configuration mode.
Step 4	<b>voice-class sip</b> <b>Example:</b> Router(config-dial-peer)# voice service voip	Enters dial-peer VoIP configuration mode.
Step 5	<b>sip</b> <b>Example:</b> Router(conf-voi-serv)# sip	Enters SIP configuration mode.
Step 6	<b>outbound-proxy {ipv4:ip-address[:port-number]   dns:host.domain}</b> <b>Example:</b> Router(conf-serv-sip)# outbound-proxy ipv4:10.1.1.1	Configures an outbound proxy server. This example shows how to configure an outbound-proxy server to IP address 10.1.1.1.
Step 7	<b>exit</b> <b>Example:</b> Router (conf-ser-sip)# exit	Exits the current mode.

## Configuring SIP Support for PAI

This section provides procedures for configuring the following supplementary services:

### Configuring a Privacy Header

To configure a privacy header in support of RFC 3323, follow these steps:

**SUMMARY STEPS**

1. **enable**
2. **configure terminal**
3. **voice service voip**
4. **sip**
5. **privacy {pstn | *privacy-option* [critical]}**
6. **exit**

**DETAILED STEPS**

	<b>Command or Action</b>	<b>Purpose</b>
<b>Step 1</b>	<b>enable</b> <b>Example:</b> <pre>Router&gt; enable</pre>	Enables privileged EXEC mode. <ul style="list-style-type: none"> <li>• Enter your password if prompted.</li> </ul>
<b>Step 2</b>	<b>configure terminal</b> <b>Example:</b> <pre>Router# configure terminal</pre>	Enters global configuration mode.
<b>Step 3</b>	<b>voice service voip</b> <b>Example:</b> <pre>Router(config)# voice service voip</pre>	Enters voice service VoIP configuration mode.
<b>Step 4</b>	<b>sip</b> <b>Example:</b> <pre>Router(conf-voi-ser)# sip</pre>	Enters SIP configuration mode.
<b>Step 5</b>	<b>privacy {pstn   <i>privacy-option</i> [critical]}</b> <b>Example:</b> <pre>Router(conf-ser-sip)# privacy pstn</pre>	Configures a privacy header set to a value supported by RFC 3323.  In this example, the privacy information from the PSTN side of a call is passed on to the VoIP side. The PSTN information is passed in the Octet 3a of the CALLING PARTY Information Element.
<b>Step 6</b>	<b>exit</b> <b>Example:</b> <pre>Router (conf-ser-sip)# exit</pre>	Exits the current mode.

**Configuring a Privacy Level**

To configure a privacy header level for PAI or PPI, follow these steps:

**SUMMARY STEPS**

1. `enable`
2. `configure terminal`
3. `voice service voip`
4. `sip`
5. `asserted-id [pai | ppi]`
6. `exit`

**DETAILED STEPS**

	<b>Command or Action</b>	<b>Purpose</b>
<b>Step 1</b>	<b>enable</b> <b>Example:</b> <pre>Router&gt; enable</pre>	Enables privileged EXEC mode. <ul style="list-style-type: none"> <li>• Enter your password if prompted.</li> </ul>
<b>Step 2</b>	<b>configure terminal</b> <b>Example:</b> <pre>Router# configure terminal</pre>	Enters global configuration mode.
<b>Step 3</b>	<b>voice service voip</b> <b>Example:</b> <pre>Router(config)# voice service voip</pre>	Enters voice service VoIP configuration mode.
<b>Step 4</b>	<b>sip</b> <b>Example:</b> <pre>Router(conf-voi-ser)# sip</pre>	Enters SIP configuration mode.
<b>Step 5</b>	<b>asserted-id [pai   ppi]</b> <b>Example:</b> <pre>Router(conf-ser-sip)# asserted-id ppi</pre>	Configures a privacy header. In this example, a P-Preferred-Identity header is configured.
<b>Step 6</b>	<b>exit</b> <b>Example:</b> <pre>Router (conf-ser-sip)# exit</pre>	Exits the current mode.

**Configuring a Name and Number in the asserted-id Header****SUMMARY STEPS**

1. `enable`
2. `configure terminal`

3. `voice service voip`
4. `sip`
5. `caller-info pstn-to-sip {unscreened discard | {from | remote-party-id | asserted-id} {name set name | number set number}}}`
6. `exit`

## DETAILED STEPS

	Command or Action	Purpose
<b>Step 1</b>	<b>enable</b> <b>Example:</b> <pre>Router&gt; enable</pre>	Enables privileged EXEC mode. <ul style="list-style-type: none"> <li>• Enter your password if prompted.</li> </ul>
<b>Step 2</b>	<b>configure terminal</b> <b>Example:</b> <pre>Router# configure terminal</pre>	Enters global configuration mode.
<b>Step 3</b>	<b>voice service voip</b> <b>Example:</b> <pre>Router(config)# voice service voip</pre>	Enters voice service VoIP configuration mode.
<b>Step 4</b>	<b>sip</b> <b>Example:</b> <pre>Router(conf-voi-ser)# sip</pre>	Enters SIP configuration mode.
<b>Step 5</b>	<b>caller-info pstn-to-sip {unscreened discard   {from   remote-party-id   asserted-id} {name set name   number set number}}}</b> <b>Example:</b> <pre>Router(conf-ser-sip)# caller-info pstn-to-sip asserted-id name set example</pre>	Configures a name that is populated in the asserted-id field.
<b>Step 6</b>	<b>exit</b> <b>Example:</b> <pre>Router (conf-ser-sip)# exit</pre>	Exits the current mode.

## Configuring SIP History-info Header Support

You can configure SIP History-info Header Support in two different configuration modes: voice service sip configuration (global level) and dial peer voice configuration (dial-peer level) mode. The gateway first checks if support is configured under the dial peer voice configuration mode, and failing a match, then defaults to the voice service configuration. If support is not configured in either mode, then the header is not added.

## Configuring SIP History-info Header Support Globally

Perform this task to configure history-info header support at a global level in SIP configuration (conf-serv-sip) mode.

### SUMMARY STEPS

1. **enable**
2. **configure terminal**
3. **voice service voip**
4. **sip**
5. **history-info**
6. **exit**

### DETAILED STEPS

	Command or Action	Purpose
Step 1	<b>enable</b> <b>Example:</b> Router> enable	Enters privileged EXEC mode, or other security level set by a system administrator. <ul style="list-style-type: none"> <li>• Enter your password if prompted.</li> </ul>
Step 2	<b>configure terminal</b> <b>Example:</b> Router# configure terminal	Enters global configuration mode.
Step 3	<b>voice service voip</b> <b>Example:</b> Router(config)# voice service voip	Enters voice service VoIP configuration mode.
Step 4	<b>sip</b> <b>Example:</b> Router(conf-voi-serv)# sip	Enters SIP configuration mode.
Step 5	<b>history-info</b> <b>Example:</b> Router(conf-serv-sip)# history-info	Configures history-info header support globally.
Step 6	<b>exit</b> <b>Example:</b> Router(conf-serv-sip)# exit	Exits the current mode.

## Configuring SIP History-info Header Support at the Dial-Peer Level

Perform this task to configure history-info header support at the dial-peer level, in dial peer voice configuration (config-dial-peer) mode.

### SUMMARY STEPS

1. **enable**
2. **configure terminal**
3. **dial-peer voice tag voip**
4. **voice-class sip history-info**
5. **exit**

### DETAILED STEPS

	Command or Action	Purpose
<b>Step 1</b>	<b>enable</b> <b>Example:</b> Router> enable	Enters privileged EXEC mode, or other security level set by a system administrator. <ul style="list-style-type: none"> <li>• Enter your password if prompted.</li> </ul>
<b>Step 2</b>	<b>configure terminal</b> <b>Example:</b> Router# configure terminal	Enters global configuration mode.
<b>Step 3</b>	<b>dial-peer voice tag voip</b> <b>Example:</b> Router(config)# dial-peer voice 2 voip	Enters dial peer VoIP configuration mode.
<b>Step 4</b>	<b>voice-class sip history-info</b> <b>Example:</b> Router(config-dial-peer)# voice-class sip history-info	Configures history-info header support for a dial peer.
<b>Step 5</b>	<b>exit</b> <b>Example:</b> Router(config-dial-peer)# exit	Exits the current mode.

## Configuring Call Routing on SIP History-info Header Support Globally

Perform this task to configure call routing on history-info header at a global level in SIP configuration (conf-serv-sip) mode.



**SUMMARY STEPS**

1. **enable**
2. **configure terminal**
3. **voice service voip**
4. **sip**
5. **call route history-info**
6. **exit**

**DETAILED STEPS**

	<b>Command or Action</b>	<b>Purpose</b>
<b>Step 1</b>	<b>enable</b> <b>Example:</b> Router> enable	Enters privileged EXEC mode, or other security level set by a system administrator. <ul style="list-style-type: none"> <li>• Enter your password if prompted.</li> </ul>
<b>Step 2</b>	<b>configure terminal</b> <b>Example:</b> Router# configure terminal	Enters global configuration mode.
<b>Step 3</b>	<b>voice service voip</b> <b>Example:</b> Router(config)# voice service voip	Enters voice service VoIP configuration mode.
<b>Step 4</b>	<b>sip</b> <b>Example:</b> Router(conf-voi-serv) # sip	Enters SIP configuration mode.
<b>Step 5</b>	<b>call route history-info</b> <b>Example:</b> Router(conf-serv-sip) # call-route history-info	Configures call-route history-info header support globally.
<b>Step 6</b>	<b>exit</b> <b>Example:</b> Router(conf-serv-sip) # exit	Exits the current mode.

**Configuring Call Routing on SIP History-info Header Support at the Dial-Peer Level**

Perform this task to configure call routing on history-info header support at the dial-peer level, in dial peer voice configuration (config-dial-peer) mode.

**SUMMARY STEPS**

1. **enable**
2. **configure terminal**
3. **dial-peer voice tag voip**
4. **voice-class sip call-route history-info**
5. **exit**

**DETAILED STEPS**

	<b>Command or Action</b>	<b>Purpose</b>
<b>Step 1</b>	<b>enable</b> <b>Example:</b> Router> enable	Enters privileged EXEC mode, or other security level set by a system administrator. <ul style="list-style-type: none"> <li>• Enter your password if prompted.</li> </ul>
<b>Step 2</b>	<b>configure terminal</b> <b>Example:</b> Router# configure terminal	Enters global configuration mode.
<b>Step 3</b>	<b>dial-peer voice tag voip</b> <b>Example:</b> Router(config)# dial-peer voice 2 voip	Enters dial peer VoIP configuration mode.
<b>Step 4</b>	<b>voice-class sip call-route history-info</b> <b>Example:</b> Router(config-dial-peer)# voice-class sip call-route history-info	Configures call-route history-info header support for a dial peer.
<b>Step 5</b>	<b>exit</b> <b>Example:</b> Router(config-dial-peer)# exit	Exits the current mode.

**Configuring SIP Trunk Registration**

The IOS Gateway registers all its POTS dial peers to the registrar when the registrar is configured on the Gateway. The gateway now supports registering the number configured in the command. With the introduction of trunk registration support, registration of a single number would represent the SIP trunk. SIP trunk registration can be associated with multiple dial peers for routing outbound calls. On successful registration, all subsequent registration refresh and outbound calls will use the same outbound proxy IP address and port used for the registration.

**SUMMARY STEPS**

1. **enable**

2. **configure terminal**
3. Do one of the following:
  - **voice service voip**
  - **dial-peer voice**
4. **sip**
5. **outbound-proxy dns:host:domain reuse**
6. Do one of the following:
  - **preloaded-route sip-server service-route**
  - **voice-class sip preloaded-route sip-server service-route**
7. **exit**
8. **exit**
9. **dial-peer voice tag pots**
10. **no sip-register**
11. **exit**
12. **sip-ua**
13. **credentials number number username username password password realm realm**
14. **registrar registrar-server-address[:port] auth-realm realm**
15. **exit**
16. Do one of the following:
  - **voice service voip**
  - **dial-peer voice**
17. **sip**
18. Do one of the following:
  - **associate registered-number number**
  - **voice-class sip associate registered-number number**
19. Do one of the following:
  - **call-route p-called-party-id**
  - or
  - **voice-class sip call-route p-called-party-id**
20. **end**

**DETAILED STEPS**

	<b>Command or Action</b>	<b>Purpose</b>
<b>Step 1</b>	<b>enable</b> <b>Example:</b> Router> enable	Enters privileged EXEC mode. Enter your password if prompted.
<b>Step 2</b>	<b>configure terminal</b> <b>Example:</b>	Enters global configuration mode.

	Command or Action	Purpose
	Router# configure terminal	
<b>Step 3</b>	<p>Do one of the following:</p> <ul style="list-style-type: none"> <li>• <b>voice service voip</b></li> <li>• <b>dial-peer voice</b></li> </ul> <p><b>Example:</b></p> <pre>Router(config)# voice service voip</pre> <p><b>Example:</b></p> <pre>Router(config)# dial-peer voice</pre>	Enters voice service VoIP configuration mode or dial peer configuration mode.
<b>Step 4</b>	<p><b>sip</b></p> <p><b>Example:</b></p> <pre>Router(config-voi-serv)# sip</pre>	Enters voice service VoIP SIP configuration mode.
<b>Step 5</b>	<p><b>outbound-proxy dns:host:domain reuse</b></p> <p><b>Example:</b></p> <pre>Router(config-serv-sip)# outbound-proxy dns:obp.twc.com reuse</pre>	Defines the outbound proxy information with the reuse option.
<b>Step 6</b>	<p>Do one of the following:</p> <ul style="list-style-type: none"> <li>• <b>preloaded-route sip-server service-route</b></li> <li>• <b>voice-class sip preloaded-route sip-server service-route</b></li> </ul> <p><b>Example:</b></p> <pre>Router(config-serv-sip)# preloaded-route sip-server service-route</pre> <p><b>Example:</b></p> <pre>Router(config-dial-peer)# voice-class sip preloaded-route sip-server service-route</pre>	Use this command under global or dial-peer configuration mode to add service route and outbound proxy information after successful trunk registration.
<b>Step 7</b>	<p><b>exit</b></p> <p><b>Example:</b></p> <pre>Router(config-serv-sip)# exit</pre>	Exits voice service VOIP SIP configuration mode and returns to the voice service VOIP mode.
<b>Step 8</b>	<p><b>exit</b></p> <p><b>Example:</b></p> <pre>Router(config-voi-serv)# exit</pre>	Exits voice service VOIP configuration mode and returns to global configuration mode.

	Command or Action	Purpose
Step 9	<p><b>dial-peer voice tag pots</b></p> <p><b>Example:</b></p> <pre>Router(config)# dial-peer voice 100 pots</pre>	<p>Enters dial-peer voice configuration mode.</p> <p><b>Note</b> Voice service configuration mode configures the gateway to support the Accept-Language header in both outgoing SIP INVITE messages and OPTIONS responses. Dial-peer voice configuration mode configures it to support the header in INVITE messages only.</p>
Step 10	<p><b>no sip-register</b></p> <p><b>Example:</b></p> <pre>Router(config-dial-peer)# no sip-register</pre>	Use this command under each dial peer to limit the gateway to register only one number.
Step 11	<p><b>exit</b></p> <p><b>Example:</b></p> <pre>Router(config-dial-peer)# exit</pre>	Exits dial-peer configuration mode and enters the global configuration mode.
Step 12	<p><b>sip-ua</b></p> <p><b>Example:</b></p> <pre>Router(config)# sip-ua</pre>	Enters SIP user-agent configuration mode.
Step 13	<p><b>credentials number number username username password password realm realm</b></p> <p><b>Example:</b></p> <pre>Router(config-sip-ua)# credentials number 1234 username abc password pass realm cisco.com</pre>	Configures a single number registration. Deregistration of the number when the POTS interface goes down will be triggered for the POTS dial peer only when the dial peer is already registered. This is not the case for the POTS interface.
Step 14	<p><b>registrar registrar-server-address[:port] auth-realm realm</b></p> <p><b>Example:</b></p> <pre>Router(config-sip-ua)# registrar ipv4:209.165.201.2 auth-realm cisco.com</pre>	Associates a protection domain with the registrar using the auth-realm option. Configure the authentication for the number with the same realm.
Step 15	<p><b>exit</b></p> <p><b>Example:</b></p> <pre>Router(config-sip-ua)# exit</pre>	Exits SIP user-agent configuration mode and enters the global configuration mode.
Step 16	<p>Do one of the following:</p> <ul style="list-style-type: none"> <li>• <b>voice service voip</b></li> <li>• <b>dial-peer voice</b></li> </ul> <p><b>Example:</b></p> <pre>Router(config)# voice service voip</pre>	Enters voice service VoIP configuration mode or dial-peer configuration mode.

	Command or Action	Purpose
	<p><b>Example:</b></p> <pre>Router(config)# dial-peer voice</pre>	
<b>Step 17</b>	<p><b>sip</b></p> <p><b>Example:</b></p> <pre>Router(config-voi-serv)# sip</pre>	Enters voice service VoIP SIP configuration mode.
<b>Step 18</b>	<p>Do one of the following:</p> <ul style="list-style-type: none"> <li>• <b>associate registered-number</b> <i>number</i></li> <li>• <b>voice-class sip associate registered-number</b> <i>number</i></li> </ul> <p><b>Example:</b></p> <pre>Router(config-voi-serv-sip)# associate registered-number 1234</pre> <p><b>Example:</b></p> <pre>Router(config-dial-peer)# voice-class sip associate registered-number 1234</pre>	Associates a registered number under a global voice service configuration level or dial peer. This is required for trunk registration to obtain the service route and outbound proxy information used for last registration.
<b>Step 19</b>	<p>Do one of the following:</p> <ul style="list-style-type: none"> <li>• <b>call-route p-called-party-id</b></li> <li>• or</li> <li>• <b>voice-class sip call-route p-called-party-id</b></li> </ul> <p><b>Example:</b></p> <pre>Router(config-voi-serv-sip)# call-route p-called-party-id</pre> <p><b>Example:</b></p> <pre>Router(config-dial-peer)# voice-class sip call-route p-called-party-id</pre>	Routes the call based on the p-called party-id header in the incoming INVITE at the global voice service configuration level or dial peer level.
<b>Step 20</b>	<p><b>end</b></p> <p><b>Example:</b></p> <pre>Router(config-serv-sip)# exit</pre>	Exits voice service VoIP SIP configuration model and returns to privileged exec mode.

## Configuring Support for SIP 181 Call is Being Forwarded Message

You can configure support for SIP 181 Call is Being Forwarded messages either globally or on a specific dial-peer. Use the **block** command in voice service SIP configuration mode to globally configure Cisco IOS voice gateways and Cisco UBEs to drop specified SIP provisional response messages. To configure settings for an individual dial peer, use the **voice-class sip block** command in dial peer voice configuration mode.

Both globally and at the dial peer level, you can also use the **sdp** keyword to further control when the specified SIP message is dropped based on either the absence or presence of SDP information.

Additionally, you can use commands introduced for this feature to configure a Cisco UBE, either globally or at the dial peer level, to map specific received SIP provisional response messages to a different SIP provisional response message on the outgoing SIP dial peer. To do so, use the **map resp-code** command in voice service SIP configuration mode for global configuration or, to configure a specific dial peer, use the **voice-class sip map resp-code** in dial peer voice configuration mode.

## Configuring Support for SIP 181 Call is Being Forwarded Message Globally

Perform this task to configure support for SIP 181 messages at a global level in SIP configuration (conf-serv-sip) mode.

### SUMMARY STEPS

1. **enable**
2. **configure terminal**
3. **voice service voip**
4. **sip**
5. **block {180 | 181 | 183} [sdp {absent | present}]**
6. **exit**

### DETAILED STEPS

	Command or Action	Purpose
Step 1	<b>enable</b> <b>Example:</b>  Router> enable	Enters privileged EXEC mode, or other security level set by a system administrator.  • Enter your password if prompted.
Step 2	<b>configure terminal</b> <b>Example:</b>  Router# configure terminal	Enters global configuration mode.
Step 3	<b>voice service voip</b> <b>Example:</b>  Router(config)# voice service voip	Enters voice service VoIP configuration mode.
Step 4	<b>sip</b> <b>Example:</b>  Router(conf-voi-serv)# sip	Enters SIP configuration mode.
Step 5	<b>block {180   181   183} [sdp {absent   present}]</b> <b>Example:</b>	Configures support of SIP 181 messages globally so that messages are passed as is. The sdp keyword is optional and allows for dropping or passing of SIP 181 messages based on the presence or absence of SDP.

	Command or Action	Purpose
	<code>Router(conf-serv-sip)# block 181 sdp present</code>	
<b>Step 6</b>	<b>exit</b> <b>Example:</b> <code>Router(conf-serv-sip)# exit</code>	Exits the current mode.

## Configuring Support for SIP 181 Call is Being Forwarded Message at the Dial-Peer Level

Perform this task to configure support for SIP 181 messages at the dial-peer level, in dial peer voice configuration (config-dial-peer) mode.

### SUMMARY STEPS

1. **enable**
2. **configure terminal**
3. **dial-peer voice tag voip**
4. **voice-class sip block {180 | 181 | 183} [sdp {absent | present}]**
5. **exit**

### DETAILED STEPS

	Command or Action	Purpose
<b>Step 1</b>	<b>enable</b> <b>Example:</b> <code>Router&gt; enable</code>	Enters privileged EXEC mode, or other security level set by a system administrator. <ul style="list-style-type: none"> <li>• Enter your password if prompted.</li> </ul>
<b>Step 2</b>	<b>configure terminal</b> <b>Example:</b> <code>Router# configure terminal</code>	Enters global configuration mode.
<b>Step 3</b>	<b>dial-peer voice tag voip</b> <b>Example:</b> <code>Router(config)# dial-peer voice 2 voip</code>	Enters dial peer VoIP configuration mode.
<b>Step 4</b>	<b>voice-class sip block {180   181   183} [sdp {absent   present}]</b> <b>Example:</b> <code>Router(config-dial-peer)# voice-class sip block 181 sdp present</code>	Configures support of SIP 181 messages on a specific dial peer so that messages are passed as is. The sdp keyword is optional and allows for dropping or passing of SIP 181 messages based on the presence or absence of SDP.



	Command or Action	Purpose
Step 5	<b>exit</b> <b>Example:</b> Router(config-dial-peer)# exit	Exits the current mode.

## Configuring Mapping of SIP Provisional Response Messages Globally

Perform this task to configure mapping of specific received SIP provisional response messages at a global level in SIP configuration (conf-serv-sip) mode.

### SUMMARY STEPS

1. enable
2. configure terminal
3. voice service voip
4. sip
5. map resp-code 181 to 183
6. exit

### DETAILED STEPS

	Command or Action	Purpose
Step 1	<b>enable</b> <b>Example:</b> Router> enable	Enters privileged EXEC mode, or other security level set by a system administrator. <ul style="list-style-type: none"> <li>• Enter your password if prompted.</li> </ul>
Step 2	<b>configure terminal</b> <b>Example:</b> Router# configure terminal	Enters global configuration mode.
Step 3	<b>voice service voip</b> <b>Example:</b> Router(config)# voice service voip	Enters voice service VoIP configuration mode.
Step 4	<b>sip</b> <b>Example:</b> Router(conf-voi-serv)# sip	Enters SIP configuration mode.
Step 5	<b>map resp-code 181 to 183</b> <b>Example:</b> Router(conf-serv-sip)# map resp-code 181 to 183	Enables mapping globally of received SIP messages of a specified message type to a different SIP message type.

	Command or Action	Purpose
<b>Step 6</b>	<b>exit</b> <b>Example:</b> <pre>Router(conf-serv-sip)# exit</pre>	Exits the current mode.

## Configuring Mapping of SIP Provisional Response Messages at the Dial-Peer Level

Perform this task to configure mapping of received SIP provisional response messages at the dial-peer level, in dial peer voice configuration (config-dial-peer) mode.

### SUMMARY STEPS

1. **enable**
2. **configure terminal**
3. **dial-peer voice tag voip**
4. **voice-class sip map resp-code 181 to 183**
5. **exit**

### DETAILED STEPS

	Command or Action	Purpose
<b>Step 1</b>	<b>enable</b> <b>Example:</b> <pre>Router&gt; enable</pre>	Enters privileged EXEC mode, or other security level set by a system administrator. <ul style="list-style-type: none"> <li>• Enter your password if prompted.</li> </ul>
<b>Step 2</b>	<b>configure terminal</b> <b>Example:</b> <pre>Router# configure terminal</pre>	Enters global configuration mode.
<b>Step 3</b>	<b>dial-peer voice tag voip</b> <b>Example:</b> <pre>Router(config)# dial-peer voice 2 voip</pre>	Enters dial peer VoIP configuration mode.
<b>Step 4</b>	<b>voice-class sip map resp-code 181 to 183</b> <b>Example:</b> <pre>Router(config-dial-peer)# voice-class sip map resp-code 181 to 183</pre>	Enables mapping of received SIP messages of a specified SIP message type on a specific dial peer to a different SIP message type.
<b>Step 5</b>	<b>exit</b> <b>Example:</b> <pre>Router(config-dial-peer)# exit</pre>	Exits the current mode.

# Configuring Support for Expires Timer Reset on Receiving or Sending SIP 183 Message

You can configure support for resetting the Expires timer upon receipt or sending of SIP 183 messages to reset the Expires timer and preserve the call until final response. You can enable this feature globally, using the **reset timer expires** command in voice service SIP configuration mode, or on a specific dial-peer using the **voice-class sip reset timer expires** command in dial peer voice configuration mode.

## Configuring Reset of Expires Timer Globally

Perform this task to enable resetting of the Expires timer at the global level in SIP configuration (conf-serv-sip) mode.

### SUMMARY STEPS

1. **enable**
2. **configure terminal**
3. **voice service voip**
4. **sip**
5. **reset timer expires 183**
6. **exit**

### DETAILED STEPS

	Command or Action	Purpose
Step 1	<b>enable</b> <b>Example:</b>  Router> enable	Enters privileged EXEC mode, or other security level set by a system administrator.  • Enter your password if prompted.
Step 2	<b>configure terminal</b> <b>Example:</b>  Router# configure terminal	Enters global configuration mode.
Step 3	<b>voice service voip</b> <b>Example:</b>  Router(config)# voice service voip	Enters voice service VoIP configuration mode.
Step 4	<b>sip</b> <b>Example:</b>  Router(conf-voi-serv)# sip	Enters SIP configuration mode.
Step 5	<b>reset timer expires 183</b> <b>Example:</b>	Enables resetting of the Expires timer on receiving SIP 183 messages globally.

	Command or Action	Purpose
	<code>Router(conf-serv-sip)# reset timer expires 183</code>	
<b>Step 6</b>	<b>exit</b> <b>Example:</b> <code>Router(conf-serv-sip)# exit</code>	Exits the current mode.

## Configuring Reset of Expires Timer at the Dial-Peer Level

Perform this task to enable resetting of the Expires timer at the dial-peer level in dial peer voice configuration (config-dial-peer) mode.

### SUMMARY STEPS

1. **enable**
2. **configure terminal**
3. **dial-peer voice tag voip**
4. **voice-class sip reset timer expires 183**
5. **exit**

### DETAILED STEPS

	Command or Action	Purpose
<b>Step 1</b>	<b>enable</b> <b>Example:</b> <code>Router&gt; enable</code>	Enters privileged EXEC mode, or other security level set by a system administrator. <ul style="list-style-type: none"> <li>• Enter your password if prompted.</li> </ul>
<b>Step 2</b>	<b>configure terminal</b> <b>Example:</b> <code>Router# configure terminal</code>	Enters global configuration mode.
<b>Step 3</b>	<b>dial-peer voice tag voip</b> <b>Example:</b> <code>Router(config)# dial-peer voice 2 voip</code>	Enters dial peer VoIP configuration mode.
<b>Step 4</b>	<b>voice-class sip reset timer expires 183</b> <b>Example:</b> <code>Router(config-dial-peer)# voice-class sip reset timer expires 183</code>	Enables resetting of the Expires timer on receiving SIP 183 messages on a specific dial peer.
<b>Step 5</b>	<b>exit</b> <b>Example:</b>	Exits the current mode.

	Command or Action	Purpose
	Router(config-dial-peer)# exit	

## Configuring Support for Stripping off Progress Indication

Perform this task to configure support for stripping off PI from incoming ISDN messages on a Cisco IOS SIP or H.323 TDM voice gateway or on a Cisco UBE.

### SUMMARY STEPS

1. **enable**
2. **configure terminal**
3. **dial-peer voice tag pots**
4. **destination-pattern** *[+]string[T]*
5. **progress\_ind** *{{alert | callproc} {enable pi-number | disable | strip [strip-pi-number]} | {connect | disconnect | progress | setup} {enable pi-number | disable}}*
6. **exit**

### DETAILED STEPS

	Command or Action	Purpose
<b>Step 1</b>	<b>enable</b> <b>Example:</b> Router> enable	Enters privileged EXEC mode, or other security level set by a system administrator.  • Enter your password if prompted.
<b>Step 2</b>	<b>configure terminal</b> <b>Example:</b> Router# configure terminal	Enters global configuration mode.
<b>Step 3</b>	<b>dial-peer voice tag pots</b> <b>Example:</b> Router(config)# dial-peer voice 3 pots	Enters dial peer POTS configuration mode.
<b>Step 4</b>	<b>destination-pattern</b> <i>[+]string[T]</i> <b>Example:</b> Router(config-dial-peer)# destination-pattern 555	Specifies either the prefix or the full E.164 telephone number to be used for a dial peer.
<b>Step 5</b>	<b>progress_ind</b> <i>{{alert   callproc} {enable pi-number   disable   strip [strip-pi-number]}   {connect   disconnect   progress   setup} {enable pi-number   disable}}</i> <b>Example:</b>	Configure an outbound dial peer to override and remove or replace the default PI in specified call message types.

	Command or Action	Purpose
	Router(config-dial-peer)# progress_ind callproc strip 8	
<b>Step 6</b>	<b>exit</b> <b>Example:</b> Router(config-dial-peer)# exit	Exits the current mode.

## Verifying SIP Message Components Session Timers and Responses Configuration

To verify SIP message components, session timers, and responses configuration, perform the following steps as appropriate (commands are listed in alphabetical order).

### SUMMARY STEPS

1. **show call active voice**
2. **show call application sessions**
3. **show call history**
4. **show logging**
5. **show running-config**
6. **show sip min-se**
7. **show sip-ua map pstn-sip**
8. **show sip-ua map sip-pstn**
9. **show sip-ua statistics**
10. **show sip-ua status**
11. **show sip-ua timers**
12. **show subscription {asnl session {active | history [errors | session-id *session-id* | url] | statistics} | sip} [summary]**

### DETAILED STEPS

#### Step 1 **show call active voice**

Use this command to display call information for voice calls in progress.

**Note** For sample output, see "Monitor the Hostname in Locally Generated SIP Headers".

#### Step 2 **show call application sessions**

Use this command to view whether the application is running.

##### **Example:**

```
Router# show call application sessions
TCL Sessions
  There are 1 active TCL sessions
```

```

      SID Name          Called   Calling   App Name          Legs
      1                50276   50280    testapp31         4
VXML Sessions
No running VXML sessions

```

**Step 3** **show call history**

Use this command, optionally with the **voice** keyword, to display the call history table for voice calls.

**Example:**

```

Router# show call history
DisconnectCause=10
DisconnectText=normal call clearing
.
.
.

```

**Note** For more sample output, see "Monitor the Hostname in Locally Generated SIP Headers".

**Step 4** **show logging**

Use this command to display the state of logging (syslog).

The following partial sample output shows that the outgoing gateway is receiving a 180 message with SDP and is configured to ignore the SDP.

**Example:**

```

Router# show logging
Log Buffer (600000 bytes):
00:12:19:%SYS-5-CONFIG_I:Configured from console by console
00:12:19:%SYS-5-CONFIG_I:Configured from console by console
00:12:20:0x639F6EEC :State change from (STATE_NONE, SUBSTATE_NONE) to
(STATE_IDLE, SUBSTATE_NONE)
00:12:20:****Adding to UAC table
00:12:20:adding call id 2 to table
00:12:20: Queued event from SIP SPI :SIPSPI_EV_CC_CALL_SETUP
00:12:20:CCSIP-SPI-CONTROL: act_idle_call_setup
00:12:20: act_idle_call_setup:Not using Voice Class Codec
00:12:20:act_idle_call_setup:preferred_codec set[0] type :g711ulaw
bytes:160
00:12:20:sipSPICopyPeerDataToCCB:From CLI:Modem NSE payload = 100,
Passthrough = 0,Modem relay = 0, Gw-Xid = 1
SPRT latency 200, SPRT Retries = 12, Dict Size = 1024
String Len = 32, Compress dir = 3
00:12:20:sipSPICanSetFallbackFlag - Local Fallback is not active
00:12:20:****Deleting from UAC table
00:12:20:****Adding to UAC table
00:12:20: Queued event from SIP SPI :SIPSPI_EV_CREATE_CONNECTION
00:12:20:0x639F6EEC :State change from (STATE_IDLE, SUBSTATE_NONE) to
(STATE_IDLE, SUBSTATE_CONNECTING)
00:12:20:0x639F6EEC :State change from (STATE_IDLE,
SUBSTATE_CONNECTING) to (STATE_IDLE, SUBSTATE_CONNECTING)
00:12:20:sipSPIUsetBillingProfile:sipCallId for billing records =
41585FCE-14F011CC-8005AF80-D4AA3153@10.1.1.42
00:12:20:CCSIP-SPI-CONTROL: act_idle_connection_created
00:12:20:CCSIP-SPI-CONTROL: act_idle_connection_created:Connid(1)
created to 10.1.1.15:5060, local_port 57838
00:12:20:CCSIP-SPI-CONTROL: sipSPIOutgoingCallSDP
00:12:20:sipSPISetMediaSrcAddr: media src addr for stream 1 = 10.1.1.42
00:12:20:sipSPIReserveRtpPort:reserved port 18978 for stream 1
00:12:20: convert_codec_bytes_to_ptime:Values :Codec:g711ulaw

```

```

codebytes :160, ptime:20
00:12:20:sip_generate_sdp_xcaps_list:Modem Relay disabled. X-cap not needed
00:12:20:Received Octet3A=0x00 -> Setting ;screen=no ;privacy=off
00:12:20:sipSPIAddLocalContact
00:12:20: Queued event from SIP SPI :SIPSPI_EV_SEND_MESSAGE
00:12:20:sip_stats_method
00:12:20:sipSPIProcessRtpSessions
00:12:20:sipSPIAddStream:Adding stream 1 (callid 2) to the VOIP RTP library
00:12:20:sipSPISetMediaSrcAddr: media src addr for stream 1 = 10.1.1.42
00:12:20:sipSPIUpdateRtcpSession:for m-line 1
00:12:20:sipSPIUpdateRtcpSession:rtcp_session info
laddr = 10.1.1.42, lport = 18978, raddr = 0.0.0.0,
rport=0, do_rtcp=FALSE
src_callid = 2, dest_callid = -1
00:12:20:sipSPIUpdateRtcpSession:No rtp session, creating a new one
00:12:20:sipSPIAddStream:In State Idle
00:12:20:act_idle_connection_created:Transaction active. Facilities will be queued.
00:12:20:0x639F6EEC :State change from (STATE_IDLE,
SUBSTATE_CONNECTING) to (STATE_SENT_INVITE, SUBSTATE_NONE)
00:12:20:Sent:
INVITE sip:222@10.1.1.15:5060 SIP/2.0
Via:SIP/2.0/UDP 10.1.1.42:5060
From:"111" <sip:111@10.1.1.42>;tag=B4DC4-9E1
To:<sip:222@10.1.1.15>
Date:Mon, 01 Mar 1993 00:12:20 GMT
Call-ID:41585FCE-14F011CC-8005AF80-D4AA3153@10.1.1.42
Supported:timer
Min-SE: 1800
Cisco-Guid:1096070726-351277516-2147659648-3567923539
User-Agent:Cisco-SIPGateway/IOS-12.x
Allow:INVITE, OPTIONS, BYE, CANCEL, ACK, PRACK, COMET, Refer , SUBSCRIBE,
NOTIFY, INFO
CSeq:101 INVITE
Max-Forwards:6
Remote-Party-ID:<sip:111@10.1.1.42>;party=calling;screen=no;privacy=off
Timestamp:730944740
Contact:<sip:111@10.1.1.42:5060>
Expires:180
Allow-Events:telephone-event
Content-Type:application/sdp
Content-Length:230
v=0
o=CiscoSystemsSIP-GW-UserAgent 4629 354 IN IP4 10.1.1.42
s=SIP Call
c=IN IP4 10.1.1.42
t=0 0
m=audio 18978 RTP/AVP 0 100
c=IN IP4 10.1.1.42
a=rtpmap:0 PCMU/8000
a=rtpmap:100 X-NSE/8000
a=fmtp:100 192-194
a=ptime:20
00:12:21:Received:
SIP/2.0 100 Trying
Via:SIP/2.0/UDP 10.1.1.42:5060
From:"111" <sip:111@10.1.1.42>;tag=B4DC4-9E1
To:<sip:222@10.1.1.15>;tag=442AC-22
Date:Wed, 16 Feb 2000 18:19:56 GMT
Call-ID:41585FCE-14F011CC-8005AF80-D4AA3153@10.1.1.42
Timestamp:730944740
Server:Cisco-SIPGateway/IOS-12.x
CSeq:101 INVITE
Allow-Events:telephone-event
Content-Length:0

```



```

00:12:21:HandleUdpSocketReads :Msg enqueued for SPI with IPaddr:
10.1.1.15:5060
00:12:21:CCSIP-SPI-CONTROL: act_sentininvite_new_message
00:12:21:CCSIP-SPI-CONTROL: sipSPICheckResponse
00:12:21:sip_stats_status_code
00:12:21: Roundtrip delay 420 milliseconds for method INVITE
00:12:21:0x639F6EEC :State change from (STATE_SENT_INVITE,
SUBSTATE_NONE) to (STATE_REC'D_PROCEEDING, SUBSTATE_PROCEEDING_PROCEEDING)
00:12:21:Received:
SIP/2.0 180 Ringing
Via:SIP/2.0/UDP 10.1.1.42:5060
From:"111" <sip:111@10.1.1.42>;tag=B4DC4-9E1
To:<sip:222@10.1.1.15>;tag=442AC-22
Date:Wed, 16 Feb 2000 18:19:56 GMT
Call-ID:41585FCE-14F011CC-8005AF80-D4AA3153@10.1.1.42
Timestamp:730944740
Server:Cisco-SIPGateway/IOS-12.x
CSeq:101 INVITE
Allow-Events:telephone-event
Contact:<sip:222@192.0.2.59:5060>
Record-Route:<sip:222@10.1.1.15:5060;maddr=10.1.1.15>
Content-Length:230
Content-Type:application/sdp
v=0
o=CiscoSystemsSIP-GW-UserAgent 4629 354 IN IP4 10.1.1.42
s=SIP Call
c=IN IP4 10.1.1.42
t=0 0
m=audio 18978 RTP/AVP 0 100
c=IN IP4 10.1.1.42
a=rtpmap:0 PCMU/8000
a=rtpmap:100 X-NSE/8000
a=fmtp:100 192-194
a=ptime:20
00:12:21:HandleUdpSocketReads :Msg enqueued for SPI with IPaddr:
10.1.1.15:5060
00:12:21:CCSIP-SPI-CONTROL: act_rec'dproc_new_message
00:12:21:CCSIP-SPI-CONTROL: act_rec'dproc_new_message_response
00:12:21:CCSIP-SPI-CONTROL: sipSPICheckResponse
00:12:21:sip_stats_status_code
00:12:21: Roundtrip delay 496 milliseconds for method INVITE
00:12:21:CCSIP-SPI-CONTROL: act_rec'dproc_new_message_response :Early
media disabled for 180:Ignoring SDP if present
00:12:21:HandleSIP1xxRinging:SDP in 180 will be ignored if present: No
early media cut through
00:12:21:HandleSIP1xxRinging:SDP Body either absent or ignored in 180
RINGING:- would wait for 200 OK to do negotiation.
00:12:21:HandleSIP1xxRinging:MediaNegotiation expected in 200 OK
00:12:21:sipSPIGetGtdBody:No valid GTD body found.
00:12:21:sipSPICreateRawMsg:No GTD passed.
00:12:21:0x639F6EEC :State change from (STATE_REC'D_PROCEEDING,
SUBSTATE_PROCEEDING_PROCEEDING) to (STATE_REC'D_PROCEEDING,
SUBSTATE_PROCEEDING_ALERTING)
00:12:21:HandleSIP1xxRinging:Transaction Complete. Lock on Facilities
released.
00:12:22:Received:
SIP/2.0 200 OK
Via:SIP/2.0/UDP 10.1.1.42:5060
From:"111" <sip:111@10.1.1.42>;tag=B4DC4-9E1
To:<sip:222@10.1.1.15>;tag=442AC-22
Date:Wed, 16 Feb 2000 18:19:56 GMT
Call-ID:41585FCE-14F011CC-8005AF80-D4AA3153@10.1.1.42
Timestamp:730944740
Server:Cisco-SIPGateway/IOS-12.x

```

```

CSeq:101 INVITE
Allow:INVITE, OPTIONS, BYE, CANCEL, ACK, PRACK, COMET, Refer , SUBSCRIBE,
NOTIFY, INFO
Allow-Events:telephone-event
Contact:<sip:222@10.1.1.59:5060>
Record-Route:<sip:222@10.1.1.15:5060;maddr=10.1.1.15>
Content-Type:application/sdp
Content-Length:231
v=0
o=CiscoSystemsSIP-GW-UserAgent 9600 4816 IN IP4 10.1.1.59
s=SIP Call
c=IN IP4 10.1.1.59
t=0 0
m=audio 19174 RTP/AVP 0 100
c=IN IP4 10.1.1.59
a=rtpmap:0 PCMU/8000
a=rtpmap:100 X-NSE/8000
a=fmtp:100 192-194
a=ptime:20

```

**Step 5**     **show running-config**

Use this command to display the contents of the currently running configuration file or the configuration for a specific interface. Use it to display the current configuration and to verify header passing and subscription configuration.

**Note**     If early media (the default setting) is enabled, this command does not show any information related to the feature.

The following sample output shows that the `disable-early-media 180` command was used.

**Example:**

```

Router# show running-config
.
.
.
dial-peer voice 223 pots
  application session
  destination-pattern 223
  port 1/0/0
!
gateway
!
sip-ua
  disable-early-media 180

```

**Step 6**     **show sip min-se**

Use this command to show the current value of a minimum-session-expiration header for calls that use SIP.

**Example:**

```

Router# show sip min-se
SIP UA MIN-SE Value (seconds)
Min-SE: 90

```

**Step 7**     **show sip-ua map pstn-sip**

Use this command to display the mapping table of PSTN cause codes and their corresponding SIP error status codes or the mapping table of PSTN-to-SIP codes.

**Example:**

```
Router# show sip-ua map pstn-sip
PSTN-Cause   Configured   Default
              SIP-Status   SIP-Status
1             404          404
2             404          404
3             404          404
4             500          500
.
.
.
110           500          500
111           400          400
126           500          500
127           500          500
```

### Step 8 show sip-ua map sip-pstn

Use this command to display the mapping table of PSTN cause codes and their corresponding SIP error status codes or the mapping table of SIP-to-PSTN codes.

#### Example:

```
Router# show sip-ua map sip-pstn
SIP-Status   Configured   Default
              PSTN-Cause   PSTN-Cause
400           127          127
401           57           57
402           21           21
403           57           57
.
.
.
600           17           17
603           21           21
604           1            1
606           58           58
```

### Step 9 show sip-ua statistics

Use this command to display response, traffic, and retry SIP statistics, including the Bad Request counter. Use it to verify configuration of the SIP INVITE Request with Malformed Via Header feature, which increments a counter (shown as *Client Error: Bad Request*) when a malformed Via header is received.

**Note** To reset counters after you view statistics, use the **clear sip-ua statistics** command.

The following sample output shows response, traffic, and retry SIP statistics, including the Bad Request counter. Use it to verify configuration of the SIP INVITE Request with Malformed Via Header feature, which increments a counter (shown as *Client Error: Bad Request*) when a malformed Via header is received.

#### Example:

```
Router# show sip-ua statistics
SIP Response Statistics (Inbound/Outbound
)
Informational:
  Trying 0/0, Ringing 0/0,
  Forwarded 0/0, Queued 0/0,
  SessionProgress 0/0
Success:
  OkInvite 0/0, OkBye 0/0,
  OkCancel 0/0, OkOptions 0/0,
```

```

    OkPrack 0/0, OkPreconditionMet 0/0
Redirection (Inbound only):
    MultipleChoice 0, MovedPermanently 0,
    MovedTemporarily 0, SeeOther 0,
    UseProxy 0, AlternateService 0
Client Error:
    BadRequest
0/0
, Unauthorized 0/0,
    PaymentRequired 0/0, Forbidden 0/0,
    NotFound 0/0, MethodNotAllowed 0/0,
    NotAcceptable 0/0, ProxyAuthReqd 0/0,
    ReqTimeout 0/0, Conflict 0/0, Gone 0/0,
    LengthRequired 0/0, ReqEntityTooLarge 0/0,
    ReqURITooLarge 0/0, UnsupportedMediaType 0/0,
    BadExtension 0/0, TempNotAvailable 0/0,
    CallLegNonExistent 0/0, LoopDetected 0/0,
    TooManyHops 0/0, AddrIncomplete 0/0,
    Ambiguous 0/0, BusyHere 0/0,
    RequestCancel 0/0, NotAcceptableMedia 0/0
Server Error:
    InternalError 0/0, NotImplemented 0/0,
    BadGateway 0/0, ServiceUnavail 0/0,
    GatewayTimeout 0/0, BadSipVer 0/0,
    PreCondFailure 0/0
Global Failure:
    BusyEverywhere 0/0, Decline 0/0,
    NotExistAnywhere 0/0, NotAcceptable 0/0
SIP Total Traffic Statistics (Inbound/Outbound)
    Invite 0/0, Ack 0/0, Bye 0/0,
    Cancel 0/0, Options 0/0,
    Prack 0/0, Comet 0/0
Retry Statistics
    Invite 0, Bye 0, Cancel 0, Response 0,
    Prack 0, Comet 0, Reliable1xx 0

```

## Step 10 show sip-ua status

Use this command to display status for the SIP user agent.

The following sample output shows status for the SIP user agent after the **disable-early-media 180** command was used.

### Example:

```

Router# show sip-ua status
SIP User Agent Status
SIP User Agent for UDP :ENABLED
SIP User Agent for TCP :ENABLED
SIP User Agent bind status(signaling):ENABLED 10.0.0.0
SIP User Agent bind status(media):ENABLED 0.0.0.0
SIP early-media for 180 responses with SDP:DISABLED
SIP max-forwards :6
SIP DNS SRV version:2 (rfc 2782)
NAT Settings for the SIP-UA
Role in SDP:NONE
Check media source packets:DISABLED
Redirection (3xx) message handling:ENABLED
SDP application configuration:
  Version line (v=) required
  Owner line (o=) required
  Timespec line (t=) required
Media supported:audio image
Network types supported:IN

```

```
Address types supported:IP4
Transport types supported:RTP/AVP udptl
```

**Step 11 show sip-ua timers**

Use this command to display all SIP UA information.

**Example:**

```
Router# show sip-ua timers
SIP UA Timer Values (milliseconds)
trying 500, expires 150000, connect 500, disconnect 500
comet 500, prack 500, rellxx 500, notify 500, refer 500,
hold 2880 minutes, buffer-invite 500
```

**Step 12 show subscription {asnl session {active | history [errors | session-id session-id | url] | statistics} | sip} [summary]**

Use this command to display information about Application SUBSCRIBE/NOTIFY Layer (ASNL)-based and non-ASNL-based SIP subscriptions.

**Example:**

```
Router# show subscription asnl session history
ASNL Subscription History Records Details:
=====
Total history records = 1
Total error count = 0
Total subscription requests sent = 1
Total subscription requests received = 0
Total notification requests sent = 0
Total notification requests received = 3
URL: sip:user@10.7.104.88
Event Name : stress
Session ID : 8
Expiration Time : 50 seconds
Subscription Duration : 10 seconds
Protocol : ASNL_PROTO_SIP
Remote IP address : 10.7.104.88
Port : 5060
Call ID : 5
Total Subscriptions Sent : 1
Total Subscriptions Received: 0
Total Notifications Sent : 0
Total Notifications Received : 3
Last response code : ASNL_UNSUBSCRIBE_SUCCESS
Last error code : ASNL_NONE
First Subscription Time : 10:55:12 UTC Apr 9 2000
Last Subscription Time : 10:55:12 UTC Apr 9 2000
First Notify Time : 10:55:12 UTC Apr 9 2000
Last Notify Time : 10:55:22 UTC Apr 9 2000
Router# show subscription asnl session history summary
ASNL Subscription History Records Summary:
=====
Total history records = 2
Total error count = 0
Total subscription requests sent = 2
Total subscription requests received = 0
Total notification requests sent = 0
Total notification requests received = 6
URL Session ID Call ID
--- -----
sip:user@10.7.104.88 9 5
sip:user@10.7.104.88 8 5
```

The following sample output shows the error type `ASNL_SUBSCRIBE_FAILED`. This error indicates that the subscription request has failed.

**Example:**

```
Router# show subscription asnl session history summary
ASNL Subscription History Records Summary:
=====
Total history records = 8
Total error count = 6
  Total error type (ASNL_SUBSCRIBE_FAILED) = 6
Total subscription requests sent = 8
Total subscription requests received = 0
Total notification requests sent = 0
Total notification requests received = 6
URL                               Session ID  Call ID
---                               -
sip:user@10.7.104.88              15         N/A
  ASNL_SUBSCRIBE_FAILED
sip:user@10.7.104.88              14         N/A
  ASNL_SUBSCRIBE_FAILED
sip:user@10.7.104.88              13         N/A
  ASNL_SUBSCRIBE_FAILED
sip:user@10.7.104.88              12         N/A
  ASNL_SUBSCRIBE_FAILED
sip:user@10.7.104.88              11         N/A
  ASNL_SUBSCRIBE_FAILED
sip:user@10.7.104.88              10         N/A
  ASNL_SUBSCRIBE_FAILED
sip:user@10.7.104.88              9          5
sip:user@10.7.104.88              8          5
Router# show subscription asnl session history error
ASNL Subscription History Error Statistics:
=====
Total history records              = 8
Total history records with errors = 6
URL      : sip:user@10.7.104.88
Session ID: 15
Call ID  : N/A
Event Name: newstress
Error    : ASNL_SUBSCRIBE_FAILED
URL      : sip:user@10.7.104.88
Session ID: 14
Call ID  : N/A
Event Name: newstress
Error    : ASNL_SUBSCRIBE_FAILED
URL      : sip:user@10.7.104.88
Session ID: 13
Call ID  : N/A
Event Name: newstress
Error    : ASNL_SUBSCRIBE_FAILED
URL      : sip:user@10.7.104.88
Session ID: 12
Call ID  : N/A
Event Name: newstress
Error    : ASNL_SUBSCRIBE_FAILED
URL      : sip:user@10.7.104.88
Session ID: 11
Call ID  : N/A
Event Name: newstress
Error    : ASNL_SUBSCRIBE_FAILED
URL      : sip:user@10.7.104.88
Session ID: 10
```

```

Call ID      : N/A
Event Name:  newstress
Error       :  ASNL_SUBSCRIBE_FAILED
Router# show subscription asnl session history url
ASNL Subscription History URL Records Details:
=====
Total history records = 3
Total history records with errors = 0
Total number of different URLs = 1
Total number of different events = 2
Total subscription requests sent = 3
Total subscription requests received = 0
Total notification requests sent = 0
Total notification requests received = 9
URL: sip:user@10.7.104.88
  Event Name: stress1
  Session ID: 19          Call ID: N/A
  Event Name: stress
  Session ID: 18          Call ID: 5
  Event Name: newstress
  Session ID: 17          Call ID: N/A
Total error count for this URL                = 0
Total events subscribed by this URL           = 0
Total subscription requests sent for this URL = 3
Total subscription requests received for this URL = 0
Total notification requests sent for this URL  = 0
Total notification requests received for this URL = 9
Router# show subscription asnl session history url summary
ASNL Subscription History URL Records Summary:
=====
Total history records = 3
Total history records with errors = 0
Total number of different URLs = 1
Total number of different events = 2
Total subscription requests sent = 3
Total subscription requests received = 0
Total notification requests sent = 0
Total notification requests received = 9
Router# show subscription asnl session statistics
ASNL Subscription and Notification Statistics:
=====
Total subscription requests sent = 3

```

## Troubleshooting Tips for SIP Message Timer and Response Features



**Note** For general troubleshooting tips and a list of important **debug** commands, see the “General Troubleshooting Tips” section of the “Basic SIP Configuration” module.

- Make sure that you can make a voice call.
- Use the **debug asnl events** command to verify that the SIP subscription server is up. For example, the output displays a pending message if the client is unsuccessful in communicating with the server:
- If this is an H.323 gateway, use the **debug cch323** family of commands to enable H.323 debugging capabilities.

- If this is a SIP gateway, use the **debug ccsip** family of commands to enable SIP debugging capabilities. Use the **debug ccsip all** command to view all the SIP messages to trace a call.
- Use the **debug isdn q931** command to display information about call setup and tear down of ISDN network connections (layer 3) between the local router (user side) and the network.
- Use the **debug radius** command to display information associated with RADIUS.
- Use the **debug voip ccapi protoheaders** command to view messages sent between the originating and terminating gateways. If no headers are being received by the terminating gateway, verify that the **header-passing** command is enabled on the originating gateway.
- Use the **debug voip ivr script** command to display any errors that might occur when the Tcl script is run.

Following is sample output for some of these commands:

### Sample Output for the debug asnl events Command

```
Router# debug asnl events
*Mar 1 02:48:48.831: //-1//ASNL:SUB7:/asnl_subscribe: resp = ASNL_SUBSCRIBE_PENDING[2]
```

### Sample Output for the debug ccsip all Command: Originating Gateway

```
Router# debug ccsip all
*Mar 1 01:45:53.783: Sent:
INVITE sip:debbie@example.com:5060 SIP/2.0
Via: SIP/2.0/UDP 10.1.1.109:5060
From: sip:nobody;tag=60F374-1061
To: sip:debbie@example.com
Date: Mon, 01 Mar 1993 01:45:53 GMT
Call-ID: 52F25057-14FD11CC-802B86FA-EE2DDC42@10.1.1.109
Subject: HelloSipTCL
AccountInfo: 123123
Priority: Urgent
testID: AL_FEAT_SIP_URL_O_RV_11
Supported: timer,100rel
Min-SE: 1800
Cisco-Guid: 1145332256-352129484-2150139642-3995982914
User-Agent: Cisco-SIPGateway/IOS-12.x
Allow: INVITE, OPTIONS, BYE, CANCEL, ACK, PRACK, COMET, Refer, SUBSCRIBE, NOTIFY, INFO
CSeq: 101 INVITE
Max-Forwards: 6
Remote-Party-ID: <sip:50006@10.1.1.109>;party=calling;screen=no;privacy=off
Timestamp: 730950353
Contact: <sip:50006@10.1.1.109:5060>
Expires: 180
Allow-Events: telephone-event
Content-Type: application/sdp
Content-Length: 234
v=0
o=CiscoSystemsSIP-GW-UserAgent 2819 5222 IN IP4 10.1.1.109
s=SIP Call
c=IN IP4 10.1.1.109
t=0 0
m=audio 16488 RTP/AVP 0 100
c=IN IP4 10.1.1.109
a=rtpmap:0 PCMU/8000
a=rtpmap:100 X-NSE/8000
```



```
a=fmtp:100 192-194
a=ptime:20
```

### Sample Output for the debug ccsip all Command: Terminating Gateway

```
*Jan 26 00:15:39.250: Received:
INVITE sip:debbie@example.com:5060 SIP/2.0
Via: SIP/2.0/UDP 10.1.1.109:5060
From: sip:nobody;tag=60F374-1061
To: sip:debbie@example.com
Date: Mon, 01 Mar 1993 01:45:53 GMT
Call-ID: 52F25057-14FD11CC-802B86FA-EE2DDC42@10.1.1.109
Subject: HelloSipTCL
AccountInfo: 123123
Priority: Urgent
testID: AL_FEAT_SIP_URL_O_RV_11
Supported: timer,100rel
Min-SE: 1800
Cisco-Guid: 1145332256-352129484-2150139642-3995982914
User-Agent: Cisco-SIPGateway/IOS-12.x
Allow: INVITE, OPTIONS, BYE, CANCEL, ACK, PRACK, COMET, Refer , SUBSCRIBE, NOTIFY, INFO
CSeq: 101 INVITE
Max-Forwards: 6
Remote-Party-ID: <sip:50006@10.1.1.109>;party=calling;screen=no;privacy=off
Timestamp: 730950353
Contact: <sip:50006@10.1.1.109:5060>
Expires: 180
Allow-Events: telephone-event
Content-Type: application/sdp
Content-Length: 234
v=0
o=CiscoSystemsSIP-GW-UserAgent 2819 5222 IN IP4 10.1.1.109
s=SIP Call
c=IN IP4 10.1.1.109
t=0 0
m=audio 16488 RTP/AVP 0 100
c=IN IP4 10.1.1.109
a=rtpmap:0 PCMU/8000
a=rtpmap:100 X-NSE/8000
a=fmtp:100 192-194
a=ptime:20
```

### Sample Output for the debug ccsip all Command: SIP Trunk Registration

```
Sent:
REGISTER sip:9.13.40.83:5099 SIP/2.0
Via: SIP/2.0/UDP 9.44.48.152:5060;branch=z9hG4bK1E19829
From: <sip:1234@9.13.40.83>;tag=187A1230-B2B
To: <sip:1234@9.13.40.83>
Call-ID: A3EC4165-192D11DF-8037BEFF-D94B81E0
Max-Forwards: 70
CSeq: 2 REGISTER
Contact: <sip:1234@9.44.48.152:5060>
Expires: 180
Supported: path
Authorization: Digest
username="test",realm="cisco.com",uri="sip:9.13.40.83:5099",response="",nonce=""
Content-Length: 0
```

### Sample Output for the debug ccsip messages Command

The following shows sample output for one side of a call.

```

Router# debug ccsip messages
SIP Call messages tracing is enabled
Router#
*Mar 6 14:19:14: Sent:
INVITE sip:3660210@192.0.2.231;user=phone;phone-context=unknown SIP/2.0
Via: SIP/2.0/UDP 192.0.2.230:55820
From: "3660110" <sip:3660110@192.0.2.230>
To: <sip:3660210@192.0.2.231;user=phone;phone-context=unknown>
Date: Sat, 06 Mar 1993 19:19:14 GMT
Call-ID: ABBAE7AF-823100E2-0-1CD274BC@172.18.192.194
Cisco-Guid: 2881152943-2184249568-0-483551624
User-Agent: Cisco VoIP Gateway/ IOS 12.x/ SIP enabled
CSeq: 101 INVITE
Max-Forwards: 6
Timestamp: 731427554
Contact: <sip:3660110@192.0.2.230:5060;user=phone>
Expires: 180
Content-Type: application/sdp
Content-Length: 138
v=0
o=CiscoSystemsSIP-GW-UserAgent 5596 7982 IN IP4 192.0.2.230
s=SIP Call
t=0 0
c=IN IP4 192.0.2.230
m=audio 20762 RTP/AVP 0
*Mar 6 14:19:14: Received:
SIP/2.0 100 Trying
Via: SIP/2.0/UDP 192.0.2.230:55820
From: "3660110" <sip:3660110@192.0.2.230>
To: <sip:3660210@192.0.2.231;user=phone;phone-context=unknown>
Date: Mon, 08 Mar 1993 22:45:12 GMT
Call-ID: ABBAE7AF-823100E2-0-1CD274BC@172.18.192.194
Timestamp: 731427554
Server: Cisco VoIP Gateway/ IOS 12.x/ SIP enabled
CSeq: 101 INVITE
Content-Length: 0
*Mar 6 14:19:14: Received:
SIP/2.0 180 Ringing
Via: SIP/2.0/UDP 192.0.2.230:55820
From: "3660110" <sip:3660110@192.0.2.230>
To: <sip:3660210@192.0.2.231;user=phone;phone-context=unknown>
Date: Mon, 08 Mar 1993 22:45:12 GMT
Call-ID: ABBAE7AF-823100E2-0-1CD274BC@172.18.192.194
Timestamp: 731427554
Server: Cisco VoIP Gateway/ IOS 12.x/ SIP enabled
CSeq: 101 INVITE
Content-Type: application/sdp
Content-Length: 138
v=0
o=CiscoSystemsSIP-GW-UserAgent 1193 7927 IN IP4 192.0.2.231
s=SIP Call
t=0 0
c=IN IP4 192.0.2.231
m=audio 20224 RTP/AVP 0
*Mar 6 14:19:16: Received:
SIP/2.0 200 OK
Via: SIP/2.0/UDP 192.0.2.230:55820
From: "3660110" <sip:3660110@192.0.2.230>
To: <sip:3660210@192.0.2.231;user=phone;phone-context=unknown>;tag=27DBC6D8-1357
Date: Mon, 08 Mar 1993 22:45:12 GMT

```

```

Call-ID: ABBAE7AF-823100E2-0-1CD274BC@172.18.192.194
Timestamp: 731427554
Server: Cisco VoIP Gateway/ IOS 12.x/ SIP enabled
Contact: <sip:3660210@192.0.2.231:5060;user=phone>
CSeq: 101 INVITE
Content-Type: application/sdp
Content-Length: 138
v=0
o=CiscoSystemsSIP-GW-UserAgent 1193 7927 IN IP4 192.0.2.231
s=SIP Call
t=0 0
c=IN IP4 192.0.2.231
m=audio 20224 RTP/AVP 0
*Mar 6 14:19:16: Sent:
ACK sip:3660210@192.0.2.231:5060;user=phone SIP/2.0
Via: SIP/2.0/UDP 192.0.2.230:55820
From: "3660110" <sip:3660110@192.0.2.230>
To: <sip:3660210@192.0.2.231;user=phone;phone-context=unknown>;tag=27DBC6D8-1357
Date: Sat, 06 Mar 1993 19:19:14 GMT
Call-ID: ABBAE7AF-823100E2-0-1CD274BC@172.18.192.194
Max-Forwards: 6
Content-Type: application/sdp
Content-Length: 138
CSeq: 101 ACK
v=0
o=CiscoSystemsSIP-GW-UserAgent 5596 7982 IN IP4 192.0.2.230
s=SIP Call
t=0 0
c=IN IP4 192.0.2.230
m=audio 20762 RTP/AVP 0
*Mar 6 14:19:19: Received:
BYE sip:3660110@192.0.2.230:5060;user=phone SIP/2.0
Via: SIP/2.0/UDP 192.0.2.231:53600
From: <sip:3660210@192.0.2.231;user=phone;phone-context=unknown>;tag=27DBC6D8-1357
To: "3660110" <sip:3660110@192.0.2.230>
Date: Mon, 08 Mar 1993 22:45:14 GMT
Call-ID: ABBAE7AF-823100E2-0-1CD274BC@172.18.192.194
User-Agent: Cisco VoIP Gateway/ IOS 12.x/ SIP enabled
Max-Forwards: 6
Timestamp: 731612717
CSeq: 101 BYE
Content-Length: 0
*Mar 6 14:19:19: Sent:
SIP/2.0 200 OK
Via: SIP/2.0/UDP 192.0.2.231:53600
From: <sip:3660210@192.0.2.231;user=phone;phone-context=unknown>;tag=27DBC6D8-1357
To: "3660110" <sip:3660110@192.0.2.230>
Date: Sat, 06 Mar 1993 19:19:19 GMT
Call-ID: ABBAE7AF-823100E2-0-1CD274BC@172.18.192.194
Server: Cisco VoIP Gateway/ IOS 12.x/ SIP enabled
Timestamp: 731612717
Content-Length:
CSeq: 101 BYE

```

The following shows sample output for the other side of the call.

```

Router# debug ccsip messages
SIP Call messages tracing is enabled
Router#
*Mar 8 17:45:12: Received:
INVITE sip:3660210@192.0.2.231;user=phone;phone-context=unknown SIP/2.0
Via: SIP/2.0/UDP 192.0.2.230:55820
From: "3660110" <sip:3660110@192.0.2.230>
To: <sip:3660210@192.0.2.231;user=phone;phone-context=unknown>

```

```

Date: Sat, 06 Mar 1993 19:19:14 GMT
Call-ID: ABBAE7AF-823100E2-0-1CD274BC@172.18.192.194
Cisco-Guid: 2881152943-2184249568-0-483551624
User-Agent: Cisco VoIP Gateway/ IOS 12.x/ SIP enabled
CSeq: 101 INVITE
Max-Forwards: 6
Timestamp: 731427554
Contact: <sip:3660110@192.0.2.230:5060;user=phone>
Expires: 180
Content-Type: application/sdp
Content-Length: 138
v=0
o=CiscoSystemsSIP-GW-UserAgent 5596 7982 IN IP4 192.0.2.230
s=SIP Call
t=0 0
c=IN IP4 192.0.2.230
m=audio 20762 RTP/AVP 0
*Mar 8 17:45:12: Sent:
SIP/2.0 100 Trying
Via: SIP/2.0/UDP 192.0.2.230:55820
From: "3660110" <sip:3660110@192.0.2.230>
To: <sip:3660210@192.0.2.231;user=phone;phone-context=unknown>
Date: Mon, 08 Mar 1993 22:45:12 GMT
Call-ID: ABBAE7AF-823100E2-0-1CD274BC@172.18.192.194
Timestamp: 731427554
Server: Cisco VoIP Gateway/ IOS 12.x/ SIP enabled
CSeq: 101 INVITE
Content-Length: 0
*Mar 8 17:45:12: Sent:
SIP/2.0 180 Ringing
Via: SIP/2.0/UDP 192.0.2.230:55820
From: "3660110" <sip:3660110@192.0.2.230>
To: <sip:3660210@192.0.2.231;user=phone;phone-context=unknown>
Date: Mon, 08 Mar 1993 22:45:12 GMT
Call-ID: ABBAE7AF-823100E2-0-1CD274BC@172.18.192.194
Timestamp: 731427554
Server: Cisco VoIP Gateway/ IOS 12.x/ SIP enabled
CSeq: 101 INVITE
Content-Type: application/sdp
Content-Length: 138
v=0
o=CiscoSystemsSIP-GW-UserAgent 1193 7927 IN IP4 192.0.2.231
s=SIP Call
t=0 0
c=IN IP4 192.0.2.231
m=audio 20224 RTP/AVP 0
*Mar 8 17:45:14: Sent:
SIP/2.0 200 OK
Via: SIP/2.0/UDP 192.0.2.230:55820
From: "3660110" <sip:3660110@192.0.2.230>
To: <sip:3660210@192.0.2.231;user=phone;phone-context=unknown>;tag=27DBC6D8-1357
Date: Mon, 08 Mar 1993 22:45:12 GMT
Call-ID: ABBAE7AF-823100E2-0-1CD274BC@172.18.192.194
Timestamp: 731427554
Server: Cisco VoIP Gateway/ IOS 12.x/ SIP enabled
Contact: <sip:3660210@192.0.2.231:5060;user=phone>
CSeq: 101 INVITE
Content-Type: application/sdp
Content-Length: 138
v=0
o=CiscoSystemsSIP-GW-UserAgent 1193 7927 IN IP4 192.0.2.231
s=SIP Call
t=0 0
c=IN IP4 192.0.2.231

```

```

m=audio 20224 RTP/AVP 0
*Mar 8 17:45:14: Received:
ACK sip:3660210@192.0.2.231:5060;user=phone SIP/2.0
Via: SIP/2.0/UDP 192.0.2.230:55820
From: "3660110" <sip:3660110@192.0.2.230>
To: <sip:3660210@192.0.2.231;user=phone;phone-context=unknown>;tag=27DBC6D8-1357
Date: Sat, 06 Mar 1993 19:19:14 GMT
Call-ID: ABBAE7AF-823100E2-0-1CD274BC@172.18.192.194
Max-Forwards: 6
Content-Type: application/sdp
Content-Length: 138
CSeq: 101 ACK
v=0
o=CiscoSystemsSIP-GW-UserAgent 5596 7982 IN IP4 192.0.2.230
s=SIP Call
t=0 0
c=IN IP4 192.0.2.230
m=audio 20762 RTP/AVP 0
*Mar 8 17:45:17: Sent:
BYE sip:3660110@192.0.2.230:5060;user=phone SIP/2.0
Via: SIP/2.0/UDP 192.0.2.231:53600
From: <sip:3660210@192.0.2.231;user=phone;phone-context=unknown>;tag=27DBC6D8-1357
To: "3660110" <sip:3660110@192.0.2.230>
Date: Mon, 08 Mar 1993 22:45:14 GMT
Call-ID: ABBAE7AF-823100E2-0-1CD274BC@172.18.192.194
User-Agent: Cisco VoIP Gateway/ IOS 12.x/ SIP enabled
Max-Forwards: 6
Timestamp: 731612717
CSeq: 101 BYE
Content-Length: 0
*Mar 8 17:45:17: Received:
SIP/2.0 200 OK
Via: SIP/2.0/UDP 192.0.2.231:53600
From: <sip:3660210@192.0.2.231;user=phone;phone-context=unknown>;tag=27DBC6D8-1357
To: "3660110" <sip:3660110@192.0.2.230>
Date: Sat, 06 Mar 1993 19:19:19 GMT
Call-ID: ABBAE7AF-823100E2-0-1CD274BC@172.18.192.194
Server: Cisco VoIP Gateway/ IOS 12.x/ SIP enabled
Timestamp: 731612717
Content-Length: 0
CSeq: 101 BYE

```

### Sample Output for the debug isdn q931 Command

The following shows sample output of a call-setup procedure for an outgoing call.

```

Router# debug isdn q931
Router# debug isdn q931
TX -> SETUP pd = 8 callref = 0x04
Bearer Capability i = 0x8890
Channel ID i = 0x83
Called Party Number i = 0x80, `415555121202'
RX <- CALL_PROC pd = 8 callref = 0x84
Channel ID i = 0x89
RX <- CONNECT pd = 8 callref = 0x84
TX -> CONNECT_ACK pd = 8 callref = 0x04....
Success rate is 0 percent (0/5)

```

The following shows sample output of a call-setup procedure for an incoming call.

```

Router# debug isdn q931
RX <- SETUP pd = 8 callref = 0x06

```

```

Bearer Capability i = 0x8890
Channel ID i = 0x89
Calling Party Number i = 0x0083, `81012345678902'
TX -> CONNECT pd = 8 callref = 0x86
RX <- CONNECT_ACK pd = 8 callref = 0x06

```

The following shows sample output of a call teardown procedure from the network.

```

Router# debug isdn q931
RX <- DISCONNECT pd = 8 callref = 0x84
Cause i = 0x8790
Looking Shift to Codeset 6
Codeset 6 IE 0x1 1 0x82 `10'
TX -> RELEASE pd = 8 callref = 0x04
Cause i = 0x8090
RX <- RELEASE_COMP pd = 8 callref = 0x84

```

The following shows sample output of a call teardown procedure from the router.

```

Router# debug isdn q931
TX -> DISCONNECT pd = 8 callref = 0x05
Cause i = 0x879081
RX <- RELEASE pd = 8 callref = 0x85
Looking Shift to Codeset 6
Codeset 6 IE 0x1 1 0x82 `10'
TX <- RELEASE_COMP pd = 8 callref = 0x05

```

### Sample Output for the debug voip ccapi protoheaders Command: Originating Gateway

```

Router# debug voip ccapi protoheaders
voip ccAPI protocol headers/bodies passing info debugging is on
*Mar 1 01:23:14.711: //-1/xxxxxxxxxxxx/CCAPI/ccGetUriDataFromTDCContainer: urlp=642D8EF0,
urlp->original_url=sip:debbie@example.com?Subject=Hello&Priority=Urgent&testID=AL_FEAT_SIP_URL_O_RV_11
*Mar 1 01:23:14.711: //-1/xxxxxxxxxxxx/CCAPI/ccSetupReqDataTDFreeHelper: data=6472C678
*Mar 1 01:23:25.155: //-1/xxxxxxxxxxxx/CCAPI/ccSetupReqDataTDFreeHelper: data=632FFD54

```

### Sample Output for the debug voip ccapi protoheaders Command: Terminating Gateway

```

*Jan 25 23:53:00.102: //-1/xxxxxxxxxxxx/CCAPI/ccGetUriDataFromTDCContainer: urlp=63CFFCD4,
urlp->original_url=sip:nobody;tag=4C3670-14E3
*Jan 25 23:53:00.102: //-1/xxxxxxxxxxxx/CCAPI/ccGetUriDataFromTDCContainer: urlp=652DAF54,
urlp->original_url=sip:debbie@example.com:5060
*Jan 25 23:53:00.110: //-1/xxxxxxxxxxxx/CCAPI/ccGetUriDataFromTDCContainer: urlp=63CFFCD4,
urlp->original_url=sip:nobody;tag=4C3670-14E3
*Jan 25 23:53:00.110: //-1/xxxxxxxxxxxx/CCAPI/ccGetUriDataFromTDCContainer: urlp=652DAF54,
urlp->original_url=sip:debbie@example.com:5060
*Jan 25 23:53:00.122: //148/256F0CED801A/CCAPI/ccGetAvlistProtoHeader: tag=35,
reqHeader=64417738, reqCount=1, sess_protocol=SIP

```

### Sample Output for the debug voip ivr script Command

In the following example, the script fails because the application that is specified in the notificationReceiver field in the script is not configured on the gateway with the **call application voicecommand**:

```

Router# debug voip ivr script
*Mar 1 02:44:24.927: //73//TCL2:/TclInterpDriver: Tcl_Eval Failed in action=act_Setup
code=1
code=ERROR
*Mar 1 02:44:24.927: IVR TCL script failure

```

```

Result:
          notifyRecr is not a configured application. Processing
subscriptionInfo array failed.
*Mar 1 02:44:24.927:  IVR TCL script failure errorInfo:
          notifyRecr is not a configured application. Processing
subscriptionInfo array failed.
          while executing
"subscription open sip:anglee@sip-server1 subinfo"
          invoked from within
"set subscription_id [subscription open sip:anglee@sip-server1 subinfo]..."
          (procedure "subscribeService" line 49)
          invoked from within
"subscribeService"
          (procedure "act_Setup" line 44)
          invoked from within
"act_Setup"

```

## Configuration Examples for SIP Message Timer and Response Features

### Internal Cause Code Consistency Between SIP and H.323 Example

This example shows a H.323 and SIP configuration with the **cause-code legacy** command configured. The **cause-code legacy** command sets internal failures with nonstandard H.323 or SIP cause codes. The **cause-code legacy** command is generally used for backward compatibility purposes, as standard cause codes are used by default.

```

Router# show running-config
Building configuration...
Current configuration : 4271 bytes
!
version 12.3
service timestamps debug datetime msec
service timestamps log datetime msec
no service password-encryption
!
enable password %1$5dQA*0
!
voice-card 3
!
ip subnet-zero
!
ip domain-name example.com
ip name-server 10.100.0.40
!
isdn switch-type primary-net5
!
voice service voip
cause-code legacy
h323
call start slow
!
no voice hpi capture buffer
no voice hpi capture destination
!
fax interface-type fax-mail

```

```

mta receive maximum-recipients 0
ccm-manager mgcp
!
controller E1 3/0
pri-group timeslots 1-31
!
controller E1 3/1
pri-group timeslots 1-31
!
interface FastEthernet0/0
ip address 10.102.0.33 255.255.255.0
duplex auto
speed auto
!
interface FastEthernet0/1
ip address 10.101.0.33 255.255.255.0
duplex auto
speed auto
h323-gateway voip interface
h323-gateway voip id gatekeeper31 ipaddr 10.101.0.35 1718
h323-gateway voip h323-id gateway31
h323-gateway voip tech-prefix 1#
!
interface Serial3/0:15
no ip address
no logging event link-status
isdn switch-type primary-net5
isdn incoming-voice voice
no cdp enable
!
interface Serial3/1:15
no ip address
no logging event link-status
isdn switch-type primary-net5
isdn incoming-voice voice
no cdp enable
!
ip classless
ip route 0.0.0.0 0.0.0.0 10.102.0.1
ip http server
ip pim bidir-enable
!
call rsvp-sync
!
voice-port 1/0/0
!
voice-port 1/0/1
!
voice-port 3/0:15
!
voice-port 3/1:15
!
mgcp ip qos dscp cs5 media
mgcp ip qos dscp cs3 signaling
!
mgcp profile default
!
dial-peer cor custom
!
dial-peer voice 1001096 pots
destination-pattern 1001096
port 1/0/0
!
dial-peer voice 1001097 pots

```



```
destination-pattern 1001097
port 1/0/1
!
dial-peer voice 1003000 pots
destination-pattern 10030..
port 3/1:15
!
dial-peer voice 1003100 pots
destination-pattern 10031..
port 3/1:15
!
dial-peer voice 2000000 voip
destination-pattern 2.....
session protocol sipv2
session target ipv4:10.101.0.40
!
dial-peer voice 3000000 voip
destination-pattern 3.....
session protocol sipv2
session target sip-server
!
dial-peer voice 4000000 voip
destination-pattern 4.....
session target ras
!
gateway
!
sip-ua
sip-server ipv4:10.100.0.40
!
line con 0
exec-timeout 0 0
line aux 0
line vty 0 4
session-timeout 20
password password
login
!
end
```

## SIP - Configurable PSTN Cause Code Mapping Example

This examples shows the two commands that change the standard mappings between the SIP and PSTN networks. The **set sip-status** command and **set pstn-cause** command are highlighted in the following configuration.

```
Router# show running-config
Building configuration...
Current configuration : 1564 bytes
!
version 12.3
service timestamps debug uptime
service timestamps log uptime
no service password-encryption
!
hostname 3660-1
!
clock timezone GMT 0
voice-card 1
!
ip subnet-zero
```

```

!
ip domain-name example.sip.com
ip name-server 10.10.1.8
!
isdn switch-type primary-5ess
!
voice service voip
    sip
!
no voice hpi capture buffer
no voice hpi capture destination
!
fax interface-type fax-mail
mta receive maximum-recipients 0
!
controller T1 1/0
    framing esf
    linecode b8zs
    ds0-group 0 timeslots 1-24 type e&m-wink-start
    ds0 busyout 2-24
!
controller T1 1/1
    framing sf
    linecode ami
!
interface FastEthernet0/0
    no ip address
    shutdown
    duplex auto
    speed auto
!
interface FastEthernet0/1
    ip address 10.10.1.3 255.255.255.0
    duplex auto
    speed auto
    ip rsvp bandwidth 75000 75000
!
ip classless
ip route 0.0.0.0 0.0.0.0 FastEthernet0/1
ip http server
ip pim bidir-enable
!
call rsvp-sync
!
voice-port 1/0:0
    output attenuation 3
!
voice-port 2/0/0
!
voice-port 2/0/1
!
voice-port 2/1/0
!
voice-port 2/1/1
!
mgcp profile default
!
dial-peer cor custom
!
dial-peer voice 3640110 voip
    application session
    incoming called-number 3640110
    destination-pattern 3640110
    rtp payload-type nte 102

```

```

session protocol sipv2
session target ipv4:10.10.1.4
dtmf-relay rtp-nte
codec g711ulaw
!
dial-peer voice 3660110 pots
application session
destination-pattern 3660110
port 2/0/0
!
sip-ua
set sip-status 486 pstn-cause 34
set pstn-cause 17 sip-status 503
no oli
!
line con 0
exec-timeout 0 0
line aux 0
line vty 0 4
login
!
end

```

## SIP Accept-Language Header Support Examples

The following provides partial output for SIP Accept-Language Header Support configured in voice service configuration mode and dial-peer configuration mode.

```

Router# show running-config
Building configuration...
Current configuration :2791 bytes
.
.
.
voice service pots
supported-language yo
supported-language sd language-param 0.234
supported-language fr language-param 0.123
.
.
.
end!
Router# show running-config
Building configuration...
Current configuration :2791 bytes
.
.
.
dial-peer voice 1 pots
application session
destination-pattern 36601
port 2/0/0
supported-language sd
supported-language zu
supported-language ln language-param 0.123
.
.
.
end!

```

## SIP Extensions for Caller Identity and Privacy Example

In the following example, the PSTN name is set to Company A and the PSTN number is set to 5550111.

```
Router(config-sip-ua)# calling-info sip-to-pstn name set CompanyA
Router(config-sip-ua)# calling-info sip-to-pstn number set 5550111
!
Router# show running-config
Building configuration...
Current configuration :2791 bytes
!
version 12.3
service timestamps debug uptime
service timestamps log uptime
no service password-encryption
!
hostname 3640
!
voice-card 2
!
ip subnet-zero
!
no ip domain lookup
ip domain name example.com
ip name-server 172.18.195.113
!
isdn switch-type primary-ni
!
fax interface-type fax-mail
mta receive maximum-recipients 0
ccm-manager mgcp
!
controller T1 2/0
 framing esf
 linecode b8zs
 pri-group timeslots 1-24
!
controller T1 2/1
 framing esf
 linecode b8zs
 pri-group timeslots 1-24
!
interface Ethernet0/0
 ip address 172.18.197.22 255.255.255.0
 half-duplex
!
interface Serial0/0
 no ip address
 shutdown
!
interface TokenRing0/0
 no ip address
 shutdown
 ring-speed 16
!
interface FastEthernet1/0
 no ip address
 shutdown
 duplex auto
 speed auto
!
interface Serial2/0:23
 no ip address
```

```
no logging event link-status
isdn switch-type primary-ni
isdn incoming-voice voice
isdn outgoing display-ie
no cdp enable
!
interface Serial2/1:23
no ip address
no logging event link-status
isdn switch-type primary-ni
isdn incoming-voice voice
isdn outgoing display-ie
no cdp enable
!
ip classless
ip route 0.0.0.0 0.0.0.0 Ethernet0/0
no ip http server
ip pim bidir-enable
!
call rsvp-sync
!
voice-port 2/0:23
!
voice-port 2/1:23
!
voice-port 3/0/0
!
voice-port 3/0/1
!
mgcp ip qos dscp cs5 media
mgcp ip qos dscp cs3 signaling
!
mgcp profile default
!
dial-peer cor custom
!
dial-peer voice 1 voip
incoming called-number 5552222
destination-pattern 5552222
session protocol sipv2
session target ipv4:172.18.197.27
!
dial-peer voice 2 pots
destination-pattern 5551111
no digit-strip
direct-inward-dial
port 2/0:23
!
gateway
!
sip-ua
calling-info sip-to-pstn name set CompanyA
calling-info sip-to-pstn number set 5550111
!
line con 0
line aux 0
line vty 0 4
login
!
end!
```

## SIP Session Timer Support Example

This example contains partial output showing that the Min-SE value has been changed from its default value. If the default value of 90 seconds remains unchanged, configuration data is not provided.

```
Router# show running-config
.
.
.
!
voice service voip
  sip
    min-se 950
!
.
.
.
```

## SIP Cisco IOS Gateway Reason Header and Buffered Calling Name Completion Examples

### Reason Header Enabled

The following examples shows output for the **show running-config** command with reason header enabled.

```
Current configuration :4643 bytes
!
version 12.3
no parser cache
service timestamps debug datetime msec localtime
service timestamps log datetime msec localtime
no service password-encryption
service internal
!
hostname cartman
!
boot-start-marker
boot-end-marker
!
no logging buffered
enable secret 5 $1$exgC$6yn9bof7/cYMhpNH9DfOp/
enable password password1
!
username 4444
username 232
username username1 password 0 password2
clock timezone EST -5
aaa new-model
!
aaa authentication login h323 group radius
aaa authorization exec h323 group radius
aaa accounting connection h323 start-stop group radius
aaa session-id common
ip subnet-zero
ip tcp path-mtu-discovery
!
ip domain name example.sip.com
ip name-server 172.18.192.48
```

```
!  
ip dhcp pool 1  
  host 172.18.193.173 255.255.255.0  
  client-identifier 0030.94c2.5d00  
  option 150 ip 172.18.193.98  
  default-router 172.18.193.98  
!  
no scripting tcl init  
no scripting tcl encdir  
!  
voice call carrier capacity active  
!  
voice service pots  
!  
voice service voip  
  sip  
  rellxx disable  
!  
voice class codec 1  
  codec preference 1 g729r8  
  codec preference 2 g711ulaw  
  codec preference 5 g726r16  
  codec preference 6 g726r24  
  codec preference 7 g726r32  
  codec preference 8 g723ar53  
  codec preference 9 g723ar63  
!  
fax interface-type fax-mail  
!  
translation-rule 100  
!  
interface FastEthernet0/0  
  ip address 172.18.193.98 255.255.255.0  
  duplex auto  
  speed auto  
  no cdp enable  
  ip rsvp bandwidth 75000 75000  
!  
interface FastEthernet0/1  
  ip address 10.1.1.98 255.0.0.0  
  shutdown  
  duplex auto  
  speed auto  
  no cdp enable  
!  
ip http server  
ip classless  
ip route 0.0.0.0 0.0.0.0 FastEthernet0/0  
ip route 10.0.0.0 255.0.0.0 172.18.193.1  
ip route 172.18.0.0 255.255.0.0 172.18.193.1  
!  
ip radius source-interface FastEthernet0/0  
logging source-interface FastEthernet0/0  
dialer-list 1 protocol ip permit  
snmp-server engineID local 00000009020000309426F6D0  
snmp-server community public RO  
snmp-server community private RW  
snmp-server packetsize 4096  
snmp-server enable traps tty  
!  
tftp-server flash:XMLDefault.cnf.xml  
!  
radius-server host 172.18.192.108 auth-port 1645 acct-port 1646  
radius-server retransmit 1
```

```

radius-server key lab
radius-server vsa send accounting
radius-server vsa send authentication
!
control-plane
!
voice-port 1/0/0
!
voice-port 1/0/1
!
voice-port 1/1/0
  station-id number 36601
  caller-id enable
!
voice-port 1/1/1
!
voice-port 2/0/0
  caller-id enable
!
voice-port 2/0/1
!
voice-port 2/1/0
!
voice-port 2/1/1
!
mgcp
mgcp sdp simple
!
dial-peer cor custom
!
dial-peer voice 6 voip
  destination-pattern 36602
  session protocol sipv2
  session target ipv4:10.102.17.80
  session transport tcp
  incoming called-number 36601
  codec g711ulaw
!
dial-peer voice 5 voip
  application session
  destination-pattern 5550123
  session protocol sipv2
  session target ipv4:172.18.197.182
!
dial-peer voice 1 pots
  destination-pattern 36601
  port 2/0/0
!
dial-peer voice 38 voip
  application session
  destination-pattern 3100802
  voice-class codec 1
  session protocol sipv2
  session target ipv4:172.18.193.99
  dtmf-relay cisco-rtsp
!
dial-peer voice 81 voip
  application session
  destination-pattern 3100801
  session protocol sipv2
  session target ipv4:172.18.193.100
  dtmf-relay rtp-nte
!
dial-peer voice 41 voip

```



```
application session
destination-pattern 777
session protocol sipv2
session target ipv4:172.18.199.94
session transport udp
!
dial-peer voice 7 voip
application session
destination-pattern 999
session protocol sipv2
session target ipv4:172.18.193.98
incoming called-number 999
!
dial-peer voice 2 pots
destination-pattern 361
port 2/1/1
!
dial-peer voice 55 voip
destination-pattern 5678
session protocol sipv2
session target ipv4:192.0.2.208:5061
!
dial-peer voice 361 voip
incoming called-number 361
!
dial-peer voice 100 voip
!
dial-peer voice 3 pots
destination-pattern 36601
port 2/0/1
!
dial-peer voice 111 pots
!
dial-peer voice 11 pots
preference 5
destination-pattern 123
port 2/0/0
!
dial-peer voice 12 pots
destination-pattern 456
port 2/0/0
!
dial-peer voice 14 pots
destination-pattern 980
port 2/0/0
!
dial-peer voice 15 pots
destination-pattern 789
port 2/0/0
!
gateway
!
sip-ua
retry invite 2
retry response 4
retry bye 2
retry cancel 1
timers expires 300000
sip-server dns:example-srv.sip.com
reason-header override ! reason header enabled
!
telephony-service
mwi relay
mwi expires 600
```

```

max-conferences 8
!
banner motd ^Chello^C
!
line con 0
  exec-timeout 0 0
  transport preferred all
  transport output all
line aux 0
  transport preferred all
  transport output all
line vty 0 4
password password1
  transport preferred all
  transport input all
  transport output all
!
end

```

The following shows output for the **show sip-ua status** command with reason header enabled.

```

SIP User Agent Status
SIP User Agent for UDP :ENABLED
SIP User Agent for TCP :ENABLED
SIP User Agent bind status(signaling):DISABLED
SIP User Agent bind status(media):DISABLED
SIP early-media for 180 responses with SDP:ENABLED
SIP max-forwards :70
SIP DNS SRV version:2 (rfc 2782)
NAT Settings for the SIP-UA
Role in SDP:NONE
Check media source packets:DISABLED
Maximum duration for a telephone-event in NOTIFYs:2000 ms
SIP support for ISDN SUSPEND/RESUME:ENABLED
Redirection (3xx) message handling:ENABLED
Reason Header will override Response/Request Codes:ENABLED ! Reason Header Enabled
SDP application configuration:
  Version line (v=) required
  Owner line (o=) required
  Timespec line (t=) required
  Media supported:audio image
  Network types supported:IN
  Address types supported:IP4
  Transport types supported:RTP/AVP udpt1

```

### Reason Header Disabled

The following shows output for the **show running-config** command with reason header disabled.

```

Current configuration :4619 bytes
!
version 12.3
no parser cache
service timestamps debug datetime msec localtime
service timestamps log datetime msec localtime
no service password-encryption
service internal
!
hostname Router
!
boot-start-marker
boot-end-marker

```

```
!  
no logging buffered  
enable secret 5 $1$exgC$6yn9bof7/cYMhpNH9DfOp/  
enable password password1  
!  
username 4444  
username 232  
username username1 password 0 password2  
clock timezone EST -5  
aaa new-model  
!  
aaa authentication login h323 group radius  
aaa authorization exec h323 group radius  
aaa accounting connection h323 start-stop group radius  
aaa session-id common  
ip subnet-zero  
ip tcp path-mtu-discovery  
!  
ip domain name example.sip.com  
ip name-server 172.18.192.48  
!  
ip dhcp pool 1  
  host 172.18.193.173 255.255.255.0  
  client-identifier 0030.94c2.5d00  
  option 150 ip 172.18.193.98  
  default-router 172.18.193.98  
!  
no scripting tcl init  
no scripting tcl encdir  
!  
voice call carrier capacity active  
!  
voice service pots  
!  
voice service voip  
  sip  
  rel1xx disable  
!  
voice class codec 1  
  codec preference 1 g729r8  
  codec preference 2 g711ulaw  
  codec preference 5 g726r16  
  codec preference 6 g726r24  
  codec preference 7 g726r32  
  codec preference 8 g723ar53  
  codec preference 9 g723ar63  
!  
fax interface-type fax-mail  
!  
translation-rule 100  
!  
interface FastEthernet0/0  
  ip address 172.18.193.98 255.255.255.0  
  duplex auto  
  speed auto  
  no cdp enable  
  ip rsvp bandwidth 75000 75000  
!  
interface FastEthernet0/1  
  ip address 10.1.1.98 255.0.0.0  
  shutdown  
  duplex auto  
  speed auto  
  no cdp enable
```

```

!
ip http server
ip classless
ip route 0.0.0.0 0.0.0.0 FastEthernet0/0
ip route 10.0.0.0 255.0.0.0 172.18.193.1
ip route 172.18.0.0 255.255.0.0 172.18.193.1
!
ip radius source-interface FastEthernet0/0
logging source-interface FastEthernet0/0
dialer-list 1 protocol ip permit
snmp-server engineID local 00000009020000309426F6D0
snmp-server community public RO
snmp-server community private RW
snmp-server packetsize 4096
snmp-server enable traps tty
!
tftp-server flash:XMLDefault.cnf.xml
!
radius-server host 172.18.192.108 auth-port 1645 acct-port 1646
radius-server retransmit 1
radius-server key lab
radius-server vsa send accounting
radius-server vsa send authentication
!
control-plane
!
voice-port 1/0/0
!
voice-port 1/0/1
!
voice-port 1/1/0
  station-id number 36601
  caller-id enable
!
voice-port 1/1/1
!
voice-port 2/0/0
  caller-id enable
!
voice-port 2/0/1
!
voice-port 2/1/0
!
voice-port 2/1/1
!
mgcp
mgcp sdp simple
!
dial-peer cor custom
!
dial-peer voice 6 voip
  destination-pattern 36602
  session protocol sipv2
  session target ipv4:10.102.17.80
  session transport tcp
  incoming called-number 36601
  codec g711ulaw
!
dial-peer voice 5 voip
  application session
  destination-pattern 5550123
  session protocol sipv2
  session target ipv4:172.18.197.182
!

```

```
dial-peer voice 1 pots
 destination-pattern 36601
 port 2/0/0
!
dial-peer voice 38 voip
 application session
 destination-pattern 3100802
 voice-class codec 1
 session protocol sipv2
 session target ipv4:172.18.193.99
 dtmf-relay cisco-rtp
!
dial-peer voice 81 voip
 application session
 destination-pattern 3100801
 session protocol sipv2
 session target ipv4:172.18.193.100
 dtmf-relay rtp-nte
!
dial-peer voice 41 voip
 application session
 destination-pattern 777
 session protocol sipv2
 session target ipv4:172.18.199.94
 session transport udp
!
dial-peer voice 7 voip
 application session
 destination-pattern 999
 session protocol sipv2
 session target ipv4:172.18.193.98
 incoming called-number 999
!
dial-peer voice 2 pots
 destination-pattern 361
 port 2/1/1
!
dial-peer voice 55 voip
 destination-pattern 5678
 session protocol sipv2
 session target ipv4:10.102.17.208:5061
!
dial-peer voice 361 voip
 incoming called-number 361
!
dial-peer voice 100 voip
!
dial-peer voice 3 pots
 destination-pattern 36601
 port 2/0/1
!
dial-peer voice 111 pots
!
dial-peer voice 11 pots
 preference 5
 destination-pattern 123
 port 2/0/0
!
dial-peer voice 12 pots
 destination-pattern 456
 port 2/0/0
!
dial-peer voice 14 pots
 destination-pattern 980
```

```

port 2/0/0
!
dial-peer voice 15 pots
 destination-pattern 789
 port 2/0/0
!
gateway
!
sip-ua
 retry invite 2
 retry response 4
 retry bye 2
 retry cancel 1
 timers expires 300000
 sip-server dns:example-srv.sip.com
!
telephony-service
 mwi relay
 mwi expires 600
 max-conferences 8
!
banner motd ^Chello^C
!
line con 0
 exec-timeout 0 0
 transport preferred all
 transport output all
line aux 0
 transport preferred all
 transport output all
line vty 0 4
password password1
 transport preferred all
 transport input all
 transport output all
!
end

```

The following shows output for the **show sip-ua status** command with reason header disabled.

```

SIP User Agent Status
SIP User Agent for UDP :ENABLED
SIP User Agent for TCP :ENABLED
SIP User Agent bind status(signaling):DISABLED
SIP User Agent bind status(media):DISABLED
SIP early-media for 180 responses with SDP:ENABLED
SIP max-forwards :70
SIP DNS SRV version:2 (rfc 2782)
NAT Settings for the SIP-UA
Role in SDP:NONE
Check media source packets:DISABLED
Maximum duration for a telephone-event in NOTIFYs:2000 ms
SIP support for ISDN SUSPEND/RESUME:ENABLED
Redirection (3xx) message handling:ENABLED
Reason Header will override Response/Request Codes:DISABLED ! Reason Header Disabled
SDP application configuration:
 Version line (v=) required
 Owner line (o=) required
 Timespec line (t=) required
 Media supported:audio image
 Network types supported:IN
 Address types supported:IP4
 Transport types supported:RTP/AVP udpt1

```

## Buffer Calling Completion Enabled

```
Current configuration :4646 bytes
!
version 12.3
no parser cache
service timestamps debug datetime msec localtime
service timestamps log datetime msec localtime
no service password-encryption
service internal
!
hostname Router
!
boot-start-marker
boot-end-marker
!
no logging buffered
enable secret 5 $1$exgC$6yn9bof7/cYMhpNH9DfOp/
enable password password1
!
username 4444
username 232
username username1 password 0 password2
clock timezone EST -5
aaa new-model
!
aaa authentication login h323 group radius
aaa authorization exec h323 group radius
aaa accounting connection h323 start-stop group radius
aaa session-id common
ip subnet-zero
ip tcp path-mtu-discovery
!
ip domain name example.sip.com
ip name-server 172.18.192.48
!
ip dhcp pool 1
  host 172.18.193.173 255.255.255.0
  client-identifier 0030.94c2.5d00
  option 150 ip 172.18.193.98
  default-router 172.18.193.98
!
no scripting tcl init
no scripting tcl encdir
!
voice call carrier capacity active
!
voice service pots
!
voice service voip
  sip
  rel1xx disable
!
voice class codec 1
  codec preference 1 g729r8
  codec preference 2 g711ulaw
  codec preference 5 g726r16
  codec preference 6 g726r24
  codec preference 7 g726r32
  codec preference 8 g723ar53
  codec preference 9 g723ar63
!
fax interface-type fax-mail
```

```

!
translation-rule 100
!
interface FastEthernet0/0
 ip address 172.18.193.98 255.255.255.0
 duplex auto
 speed auto
 no cdp enable
 ip rsvp bandwidth 75000 75000
!
interface FastEthernet0/1
 ip address 10.1.1.98 255.0.0.0
 shutdown
 duplex auto
 speed auto
 no cdp enable
!
ip http server
ip classless
ip route 0.0.0.0 0.0.0.0 FastEthernet0/0
ip route 10.0.0.0 255.0.0.0 172.18.193.1
ip route 172.18.0.0 255.255.0.0 172.18.193.1
!
ip radius source-interface FastEthernet0/0
logging source-interface FastEthernet0/0
dialer-list 1 protocol ip permit
snmp-server engineID local 00000009020000309426F6D0
snmp-server community public RO
snmp-server community private RW
snmp-server packetsize 4096
snmp-server enable traps tty
!
tftp-server flash:XMLDefault.cnf.xml
!
radius-server host 172.18.192.108 auth-port 1645 acct-port 1646
radius-server retransmit 1
radius-server key lab
radius-server vsa send accounting
radius-server vsa send authentication
!
control-plane
!
voice-port 1/0/0
!
voice-port 1/0/1
!
voice-port 1/1/0
 station-id number 36601
 caller-id enable
!
voice-port 1/1/1
!
voice-port 2/0/0
 caller-id enable
!
voice-port 2/0/1
!
voice-port 2/1/0
!
voice-port 2/1/1
!
mgcp
mgcp sdp simple
!

```



```
dial-peer cor custom
!
dial-peer voice 6 voip
 destination-pattern 36602
 session protocol sipv2
 session target ipv4:10.102.17.80
 session transport tcp
 incoming called-number 36601
 codec g711ulaw
!
dial-peer voice 5 voip
 application session
 destination-pattern 5550123
 session protocol sipv2
 session target ipv4:172.18.197.182
!
dial-peer voice 1 pots
 destination-pattern 36601
 port 2/0/0
!
dial-peer voice 38 voip
 application session
 destination-pattern 3100802
 voice-class codec 1
 session protocol sipv2
 session target ipv4:172.18.193.99
 dtmf-relay cisco-rtsp
!
dial-peer voice 81 voip
 application session
 destination-pattern 3100801
 session protocol sipv2
 session target ipv4:172.18.193.100
 dtmf-relay rtp-nte
!
dial-peer voice 41 voip
 application session
 destination-pattern 777
 session protocol sipv2
 session target ipv4:172.18.199.94
 session transport udp
!
dial-peer voice 7 voip
 application session
 destination-pattern 999
 session protocol sipv2
 session target ipv4:172.18.193.98
 incoming called-number 999
!
dial-peer voice 2 pots
 destination-pattern 361
 port 2/1/1
!
dial-peer voice 55 voip
 destination-pattern 5678
 session protocol sipv2
 session target ipv4:10.102.17.208:5061
!
dial-peer voice 361 voip
 incoming called-number 361
!
dial-peer voice 100 voip
!
dial-peer voice 3 pots
```

```

destination-pattern 36601
port 2/0/1
!
dial-peer voice 111 pots
!
dial-peer voice 11 pots
preference 5
destination-pattern 123
port 2/0/0
!
dial-peer voice 12 pots
destination-pattern 456
port 2/0/0
!
dial-peer voice 14 pots
destination-pattern 980
port 2/0/0
!
dial-peer voice 15 pots
destination-pattern 789
port 2/0/0
!
gateway
!
sip-ua
retry invite 2
retry response 4
retry bye 2
retry cancel 1
timers expires 300000
timers buffer-invite 5000 ! Buffer Calling Completion enabled
sip-server dns:example-srv.sip.com
!
!
telephony-service
mwi relay
mwi expires 600
max-conferences 8
!
banner motd ^Chello^C
!
line con 0
exec-timeout 0 0
transport preferred all
transport output all
line aux 0
transport preferred all
transport output all
line vty 0 4
password password1
transport preferred all
transport input all
transport output all
!
end

```

### Buffer Calling Completion Disabled

```

Current configuration :4619 bytes
!
version 12.3
no parser cache
service timestamps debug datetime msec localtime

```

```
service timestamps log datetime msec localtime
no service password-encryption
service internal
!
hostname Router
!
boot-start-marker
boot-end-marker
!
no logging buffered
enable secret 5 $1$exgC$6yn9bof7/cYMhpNH9DfOp/
enable password password1
!
username 4444
username 232
username username1 password 0 password2
clock timezone EST -5
aaa new-model
!
aaa authentication login h323 group radius
aaa authorization exec h323 group radius
aaa accounting connection h323 start-stop group radius
aaa session-id common
ip subnet-zero
ip tcp path-mtu-discovery
!
ip domain name example.sip.com
ip name-server 172.18.192.48
!
ip dhcp pool 1
  host 172.18.193.173 255.255.255.0
  client-identifier 0030.94c2.5d00
  option 150 ip 172.18.193.98
  default-router 172.18.193.98
!
no scripting tcl init
no scripting tcl encdir
!
voice call carrier capacity active
!
voice service pots
!
voice service voip
  sip
  rel1xx disable
!
voice class codec 1
  codec preference 1 g729r8
  codec preference 2 g711ulaw
  codec preference 5 g726r16
  codec preference 6 g726r24
  codec preference 7 g726r32
  codec preference 8 g723ar53
  codec preference 9 g723ar63
!
fax interface-type fax-mail
!
translation-rule 100
!
interface FastEthernet0/0
  ip address 172.18.193.98 255.255.255.0
  duplex auto
  speed auto
  no cdp enable
```

```

    ip rsvp bandwidth 75000 75000
    !
interface FastEthernet0/1
  ip address 10.1.1.98 255.0.0.0
  shutdown
  duplex auto
  speed auto
  no cdp enable
  !
ip http server
ip classless
ip route 0.0.0.0 0.0.0.0 FastEthernet0/0
ip route 10.0.0.0 255.0.0.0 172.18.193.1
ip route 172.18.0.0 255.255.0.0 172.18.193.1
!
ip radius source-interface FastEthernet0/0
logging source-interface FastEthernet0/0
dialer-list 1 protocol ip permit
snmp-server engineID local 00000009020000309426F6D0
snmp-server community public RO
snmp-server community private RW
snmp-server packetsize 4096
snmp-server enable traps tty
!
tftp-server flash:XMLDefault.cnf.xml
!
radius-server host 172.18.192.108 auth-port 1645 acct-port 1646
radius-server retransmit 1
radius-server key lab
radius-server vsa send accounting
radius-server vsa send authentication
!
control-plane
!
voice-port 1/0/0
!
voice-port 1/0/1
!
voice-port 1/1/0
  station-id number 36601
  caller-id enable
!
voice-port 1/1/1
!
voice-port 2/0/0
  caller-id enable
!
voice-port 2/0/1
!
voice-port 2/1/0
!
voice-port 2/1/1
!
mgcp
mgcp sdp simple
!
dial-peer cor custom
!
dial-peer voice 6 voip
  destination-pattern 36602
  session protocol sipv2
  session target ipv4:192.0.2.80
  session transport tcp
  incoming called-number 36601

```

```
    codec g711ulaw
  !
dial-peer voice 5 voip
  application session
  destination-pattern 5550123
  session protocol sipv2
  session target ipv4:172.18.197.182
  !
dial-peer voice 1 pots
  destination-pattern 36601
  port 2/0/0
  !
dial-peer voice 38 voip
  application session
  destination-pattern 3100802
  voice-class codec 1
  session protocol sipv2
  session target ipv4:172.18.193.99
  dtmf-relay cisco-rtp
  !
dial-peer voice 81 voip
  application session
  destination-pattern 3100801
  session protocol sipv2
  session target ipv4:172.18.193.100
  dtmf-relay rtp-nte
  !
dial-peer voice 41 voip
  application session
  destination-pattern 777
  session protocol sipv2
  session target ipv4:172.18.199.94
  session transport udp
  !
dial-peer voice 7 voip
  application session
  destination-pattern 999
  session protocol sipv2
  session target ipv4:172.18.193.98
  incoming called-number 999
  !
dial-peer voice 2 pots
  destination-pattern 361
  port 2/1/1
  !
dial-peer voice 55 voip
  destination-pattern 5678
  session protocol sipv2
  session target ipv4:10.102.17.208:5061
  !
dial-peer voice 361 voip
  incoming called-number 361
  !
dial-peer voice 100 voip
  !
dial-peer voice 3 pots
  destination-pattern 36601
  port 2/0/1
  !
dial-peer voice 111 pots
  !
dial-peer voice 11 pots
  preference 5
  destination-pattern 123
```

```

port 2/0/0
!
dial-peer voice 12 pots
destination-pattern 456
port 2/0/0
!
dial-peer voice 14 pots
destination-pattern 980
port 2/0/0
!
dial-peer voice 15 pots
destination-pattern 789
port 2/0/0
!
gateway
!
sip-ua
retry invite 2
retry response 4
retry bye 2
retry cancel 1
timers expires 300000
sip-server dns:example-srv.sip.com
!
telephony-service
mwi relay
mwi expires 600
max-conferences 8
!
banner motd ^Chello^C
!
line con 0
exec-timeout 0 0
transport preferred all
transport output all
line aux 0
transport preferred all
transport output all
line vty 0 4
password password1
transport preferred all
transport input all
transport output all
!
end

```

## SIP SIP Header URL Support and SUBSCRIBE NOTIFY for External Triggers Examples

### SIP Header Support and Subscription

In the following example, header passing is enabled and a default server IP address is configured. The history log is configured to retain 100 history records, each of which is retained for fifteen minutes after the subscription is removed. SUBSCRIBE messages are configured to retransmit six times.

```

Router# show running-config
Building configuration...
version 12.2
no service pad

```

```
service timestamps debug datetime msec
service timestamps log uptime
no service password-encryption
service internal
!
hostname Router
!
subscription asnl session history duration 15
subscription asnl session history count 100
logging buffered 1000000 debugging
!
resource-pool disable
!
ip subnet-zero
ip host server.example.com 10.7.104.88
!!
isdn switch-type primary-5ess
isdn voice-call-failure 0
!
voice call carrier capacity active
!
voice service voip
h323
sip
!!
The Cisco IOS VoiceXML features are enabled, and the maximum number of subscriptions to be
  originated by the gateway is configured.
header-passing
subscription maximum originate 200
!
mta receive maximum-recipients 0
!
controller T1 0
  framing esf
  clock source line primary
  linecode b8zs
  cablelength short 133
  pri-group timeslots 1-24
!
controller T1 1
  framing sf
  clock source line secondary 1
  linecode ami
!
controller T1 2
  framing sf
  clock source line secondary 2
  linecode ami
!
controller T1 3
  framing sf
  clock source line secondary 3
  linecode ami
!
interface Ethernet0
  ip address 10.7.102.35 255.255.0.0
  ip helper-address 223.255.254.254
  no ip mroute-cache
  no cdp enable
!
interface Serial0
  no ip address
  no ip mroute-cache
  shutdown
```

```

clockrate 2015232
no fair-queue
no cdp enable
!
interface Serial1
no ip address
no ip mroute-cache
shutdown
clockrate 2015232
no fair-queue
no cdp enable
!
interface Serial2
no ip address
no ip mroute-cache
shutdown
clockrate 2015232
no fair-queue
no cdp enable
!
interface Serial3
no ip address
no ip mroute-cache
shutdown
clockrate 2015232
no fair-queue
no cdp enable
!
interface Serial0:23
no ip address
ip mroute-cache
dialer-group 1
isdn switch-type primary-5ess
isdn incoming-voice modem
isdn disconnect-cause 1
fair-queue 64 256 0
no cdp enable
!
interface FastEthernet0
ip address 172.19.139.114 255.255.255.0
no ip mroute-cache
duplex auto
speed auto
no cdp enable
!
ip default-gateway 172.19.139.1
ip classless
ip route 172.71.56.39 255.255.255.255 172.19.139.1
ip route 10.255.254.0 255.255.255.0 10.7.104.1
no ip http server
!
ip pim bidir-enable
!
!
no cdp run
!
call application voice mwi tftp://dirt/ramsubra/cli_mwi.tcl
!
voice-port 0:D
!
no mgcp timer receive-rtcp
!
mgcp profile default
!

```



```

dial-peer cor custom
!
dial-peer voice 1 pots
  application mwi
  destination-pattern 408.....
  incoming called-number 52943
  port 0:D
  prefix 950
!
dial-peer voice 789 voip
  destination-pattern 789
  session target ipv4:10.7.104.88
  codec g711ulaw
!
dial-peer voice 766 voip
  application get_headers_tcl
  session protocol sipv2
  session target ipv4:10.7.102.35
  incoming uri request 766
  codec g711ulaw
!
dial-peer voice 88888 pots
  destination-pattern 767....
  port 0:D
  prefix 9767
!
sip-ua
  retry subscribe 6
!
line con 0
  exec-timeout 0 0
  logging synchronous level all
line aux 0
line vty 0 4
!
end

```

## SIP Domain Name Support in SIP Headers Examples

### Configuration in Gateway-Wide Global Configuration Mode

The following example shows the command output when the local hostname uses the gateway-wide global configuration settings.

```

Router# show running-config
Building configuration...
Current configuration :3512 bytes
!
! Last configuration change at 14:25:20 EDT Tue Aug 31 2004
! NVRAM config last updated at 14:17:44 EDT Tue Aug 31 2004
!
version 12.3
service timestamps debug datetime msec localtime
service timestamps log datetime msec localtime
no service password-encryption
! voice service voip
  sip
    localhost dns:example.com
!
!

```

### Configuration in Dial-Peer-Specific Dial-Peer Configuration Mode

The following example shows the command output when the local hostname uses the dial-peer configuration settings.

```
Router# show running-config
Building configuration...
Current configuration :3512 bytes
!
! Last configuration change at 14:25:20 EDT Tue Aug 31 2004
! NVRAM config last updated at 14:17:44 EDT Tue Aug 31 2004
!
version 12.3
service timestamps debug datetime msec localtime
service timestamps log datetime msec localtime
no service password-encryption
!
!
dial-peer voice 3301 voip
destination-pattern 9002
voice-class sip localhost dns:gw11.example.com
session protocol sipv2
session target dns:example.sip.com
session transport tcp
dtmf-relay rtp-nte
!
```

## SIP Gateway Support for Permit Hostname Example

The following example shows a configured list of hostnames.

```
router>
enable
router#
configure terminal
router (config)#
sip-ua
router (config-sip-ua)#
permit hostname dns:
esample1.sip.com
router (config-sip-ua)#
permit hostname dns:example2.sip.comrouter (config-sip-ua)#
permit hostname dns:example3.sip.comrouter (config-sip-ua)#
permit hostname dns:example4.sip.comrouter (config-sip-ua)#
permit hostname dns:example5.sip.comrouter (config-sip-ua)#
exit
```

## Outbound-Proxy Support for the SIP Gateway Examples

The following example shows how to configure an outbound-proxy server globally on a gateway for the specified IP address:

```
gateway> enable
gateway# configure terminal
Enter configuration commands, one per line. End with CNTL/Z.
gateway(config)# voice service voip
gateway(conf-voi-serv)# sip
gateway(conf-serv-sip)# outbound-proxy ipv4:10.1.1.1
```

The following example shows how to configure an outbound-proxy server globally on a gateway for the specified domain:

```
gateway> enable
gateway# configure terminal
Enter configuration commands, one per line. End with CNTL/Z.
gateway(config)# voice service voip
gateway(conf-voi-serv)# sip
gateway(conf-serv-sip)# outbound-proxy dns:sipproxy.example.com
```

The following examples shows how to configure an outbound-proxy server on a dial peer for the specified IP address:

```
gateway> enable
gateway# configure terminal
Enter configuration commands, one per line. End with CNTL/Z.
gateway(config)# dial-peer voice 111 voip
gateway(conf-dial-peer)# voice-class sip
gateway(conf-dial-peer)# outbound-proxy ipv4:10.1.1.1
```

The following examples shows how to configure an outbound-proxy server on a dial peer for the specified domain:

```
gateway> enable
gateway# configure terminal
Enter configuration commands, one per line. End with CNTL/Z.
gateway(config)# dial-peer voice 111 voip
gateway(conf-dial-peer)# voice-class sip
gateway(conf-dial-peer)# outbound-proxy dns:sipproxy.example.com
```

The following example shows how to disable the global outbound proxy feature for all line-side SIP phones on Cisco Unified CME:

```
gateway> enable
gateway# configure
  terminal
Enter configuration commands, one per line. End with CNTL/Z.
gateway(config)# voice register global
gateway(config-register-global)# no outbound-proxy
```

## SIP SIP Support for PAI Examples

### Configuring a Privacy Header Example

```
gateway> enable
gateway# configure terminal
Enter configuration commands, one per line. End with CNTL/Z.
gateway(config)# voice service voip
gateway(conf-voi-serv)# sip
gateway(conf-serv-sip)# privacy
```

### Configuring PPI Example

The following example shows how to configure a privacy header level for PPI:

```
gateway> enable
```

```
gateway# configure terminal
Enter configuration commands, one per line. End with CNTL/Z.
gateway(config)# voice service voip
gateway(conf-voi-serv)# sip
gateway(conf-serv-sip)# asserted-id ppi
```

## Configuring PAI Example

The following example shows how to configure a privacy header level for PAI:

```
gateway> enable
gateway# configure terminal
Enter configuration commands, one per line. End with CNTL/Z.
gateway(config)# voice service voip
gateway(conf-voi-serv)# sip
gateway(conf-serv-sip)# asserted-id pai
```

## SIP History-Info Header Support Examples

The following example shows how to configure history-info header support at the global level:

```
gateway> enable
gateway# configure terminal
Enter configuration commands, one per line. End with CNTL/Z.
gateway(config)# voice service voip
gateway(conf-voi-serv)# sip
gateway(conf-serv-sip)# history-info
```

The following example shows partial output from the **show running-config** command when history-info header support is configured at the global level:

```
gateway# show running-config
Building configuration...
Current configuration : 10198 bytes
.
.
voice service voip
  fax protocol t38 ls-redundancy 0 hs-redundancy 0 fallback none
  sip
    privacy user critical
    history-info
.
.
dial-peer voice 1 voip
  voice-class sip resource priority namespace drsn
  voice-class sip privacy header id critical
!
dial-peer voice 2 voip
  voice-class sip privacy header critical
.
.
end
```

The following example shows how to configure history-info header support at the dial-peer level:

```
gateway> enable
gateway# configure terminal
Enter configuration commands, one per line. End with CNTL/Z.
```

```
gateway(config)# dial-peer voice 2 voip
gateway(config-dial-peer)# voice-class sip history-info
```

The following example shows partial output from the **show running-config** command when history-info header support is configured at the dial-peer level:

```
gateway# show running-config
Building configuration...
Current configuration : 10183 bytes
.
.
voice service voip
  fax protocol t38 ls-redundancy 0 hs-redundancy 0 fallback none
  sip
    privacy user critical
.
.
dial-peer voice 1 voip
voice-class sip resource priority namespace drsn
voice-class sip privacy header id critical
!
dial-peer voice 2 voip
  voice-class sip privacy header history critical
.
.
end
```

## Additional References

The following sections provide references related to the SIP message, timer, and response features.

### Related Documents

Related Topic	Document Title
“Achieving SIP RFC Compliance” module	<i>Cisco IOS SIP Configuration Guide</i>
“Overview of SIP” module	<i>Cisco IOS SIP Configuration Guide</i>
<i>Cisco IOS Tcl IVR and VoiceXML Application Guide</i>	Cisco IOS Release 12.3(14)T and later: <a href="http://www.cisco.com/en/US/docs/ios/voice/ivr/configuration/guide/tcl_c.html">http://www.cisco.com/en/US/docs/ios/voice/ivr/configuration/guide/tcl_c.html</a>
	Cisco IOS releases prior to 12.3(14)T: <a href="http://www.cisco.com/en/US/docs/ios/voice/ivr/pre12.3_14_t/configuration/guide/ivrapp.pdf">http://www.cisco.com/en/US/docs/ios/voice/ivr/pre12.3_14_t/configuration/guide/ivrapp.pdf</a>
<i>Cisco IOS Voice Command Reference</i>	<a href="http://www.cisco.com/en/US/docs/ios/voice/command/reference/vr_book.html">http://www.cisco.com/en/US/docs/ios/voice/command/reference/vr_book.html</a>

Related Topic	Document Title
<i>Cisco Unified Communications Manager Express Command Reference</i>	<a href="http://www.cisco.com/en/US/docs/voice_ip_comm/cucme/command/reference/cme_cr.html">http://www.cisco.com/en/US/docs/voice_ip_comm/cucme/command/reference/cme_cr.html</a>
Cisco Unified Communications Manager Express support documentation	<a href="http://www.cisco.com/en/US/products/sw/voicesw/ps4625/tsd_products_support_series_home.html">http://www.cisco.com/en/US/products/sw/voicesw/ps4625/tsd_products_support_series_home.html</a>
<i>Cisco Unified SIP SRST System Administrator Guide</i>	<a href="http://www.cisco.com/en/US/docs/voice_ip_comm/cusrst/admin/sccp_sip_srst/configuration/guide/srst_">http://www.cisco.com/en/US/docs/voice_ip_comm/cusrst/admin/sccp_sip_srst/configuration/guide/srst_</a>
<i>Cisco VoiceXML Programmer's Guide</i>	<a href="http://www.cisco.com/en/US/docs/ios/voice/vxml/developer/guide/vxmlprg.html">http://www.cisco.com/en/US/docs/ios/voice/vxml/developer/guide/vxmlprg.html</a>
<i>Tcl IVR API Version 2.0 Programming Guide</i>	<a href="http://www.cisco.com/en/US/docs/ios/voice/tcl/developer/guide/tclivr2.html">http://www.cisco.com/en/US/docs/ios/voice/tcl/developer/guide/tclivr2.html</a>

### Standards

Standard	Title
International Organization for Standardization (ISO) specification, ISO 639	<a href="#">Codes for Representation of Names of Languages</a>

### MIBs

MIB	MIBs Link
None	To locate and download MIBs for selected platforms, Cisco IOS releases, and feature sets, use Cisco MIB Locator found at the following URL: <a href="http://www.cisco.com/go/mibs">http://www.cisco.com/go/mibs</a>

**RFCs**

<b>RFC</b>	<b>Title</b>
RFC 2833	<a href="#">RTP Payload for DTMF Digits, Telephony Tones and Telephony Signals</a>
RFC 3261	<a href="#">SIP: Session Initiation Protocol</a>
RFC 3262	<a href="#">Reliability of Provisional Responses in the Session Initiation Protocol (SIP)</a>
RFC 3264	<a href="#">An Offer/Answer Model with the Session Description Protocol (SDP)</a>
RFC 3265	<a href="#">Session Initiation Protocol (SIP)-Specific Event Notification</a>
RFC 3312	<a href="#">Integration of Resource Management and Session Initiation Protocol (SIP)</a>
RFC 3323	<a href="#">A Privacy Mechanism for the Session Initiation Protocol (SIP)</a>
RFC 3325	<a href="#">Private Extensions to the Session Initiation Protocol (SIP) for Asserted Identity within Trusted Networks</a>
RFC 3326	<a href="#">The Reason Header Field for the Session Initiation Protocol (SIP)</a>
RFC 4028	<a href="#">Session Timers in the Session Initiation Protocol (SIP)</a>
RFC 4244	<a href="#">An Extension to the Session Initiation Protocol (SIP) for Request History Information</a>

**Technical Assistance**

<b>Description</b>	<b>Link</b>
<p>The Cisco Support website provides extensive online resources, including documentation and tools for troubleshooting and resolving technical issues with Cisco products and technologies.</p> <p>To receive security and technical information about your products, you can subscribe to various services, such as the Product Alert Tool (accessed from Field Notices), the Cisco Technical Services Newsletter, and Really Simple Syndication (RSS) Feeds.</p> <p>Access to most tools on the Cisco Support website requires a Cisco.com user ID and password.</p>	<a href="http://www.cisco.com/techsupport">http://www.cisco.com/techsupport</a>

