



BGP Support for 4-byte ASN

The Cisco implementation of 4-byte autonomous system (AS) numbers uses asplain (65538, for example) as the default regular expression match and the output display format for AS numbers. However, you can configure 4-byte AS numbers in both the asplain format and the asdot format as described in RFC 5396. In addition, 4-byte ASN route distinguisher (RD) and route target (RT) BGP support for 4-byte autonomous numbers is added.

- [Finding Feature Information, page 1](#)
- [Information About BGP Support for 4-byte ASN, page 1](#)
- [How to Configure BGP Support for 4-byte ASN, page 5](#)
- [Configuration Examples for BGP Support for 4-byte ASN, page 11](#)
- [Additional References for BGP Support for 4-byte ASN, page 16](#)
- [Feature Information for BGP Support for 4-byte ASN, page 17](#)

Finding Feature Information

Your software release may not support all the features documented in this module. For the latest caveats and feature information, see [Bug Search Tool](#) and the release notes for your platform and software release. To find information about the features documented in this module, and to see a list of the releases in which each feature is supported, see the feature information table at the end of this module.

Use Cisco Feature Navigator to find information about platform support and Cisco software image support. To access Cisco Feature Navigator, go to www.cisco.com/go/cfn. An account on Cisco.com is not required.

Information About BGP Support for 4-byte ASN

BGP Autonomous System Number Formats

Prior to January 2009, BGP autonomous system (AS) numbers that were allocated to companies were 2-octet numbers in the range from 1 to 65535 as described in RFC 4271, *A Border Gateway Protocol 4 (BGP-4)*. Due to increased demand for AS numbers, the Internet Assigned Number Authority (IANA) started to allocate

four-octet AS numbers in the range from 65536 to 4294967295. RFC 5396, *Textual Representation of Autonomous System (AS) Numbers*, documents three methods of representing AS numbers. Cisco has implemented the following two methods:

- **Asplain**—Decimal value notation where both 2-byte and 4-byte AS numbers are represented by their decimal value. For example, 65526 is a 2-byte AS number and 234567 is a 4-byte AS number.
- **Asdot**—Autonomous system dot notation where 2-byte AS numbers are represented by their decimal value and 4-byte AS numbers are represented by a dot notation. For example, 65526 is a 2-byte AS number and 1.169031 is a 4-byte AS number (this is dot notation for the 234567 decimal number).

For details about the third method of representing autonomous system numbers, see RFC 5396.

Asdot Only Autonomous System Number Formatting

In Cisco IOS XE Release 2.3, the 4-octet (4-byte) AS numbers are entered and displayed only in asdot notation, for example, 1.10 or 45000.64000. When using regular expressions to match 4-byte AS numbers the asdot format includes a period, which is a special character in regular expressions. A backslash must be entered before the period (for example, 1\.14) to ensure the regular expression match does not fail. The table below shows the format in which 2-byte and 4-byte AS numbers are configured, matched in regular expressions, and displayed in **show** command output in Cisco IOS images where only asdot formatting is available.

Table 1: Asdot Only 4-Byte AS Number Format

Format	Configuration Format	Show Command Output and Regular Expression Match Format
asdot	2-byte: 1 to 65535 4-byte: 1.0 to 65535.65535	2-byte: 1 to 65535 4-byte: 1.0 to 65535.65535

Asplain as Default AS Number Formatting

In Cisco IOS XE Release 2.4 and later releases, the Cisco implementation of 4-byte AS numbers uses asplain as the default display format for AS numbers, but you can configure 4-byte AS numbers in both the asplain and asdot format. In addition, the default format for matching 4-byte AS numbers in regular expressions is asplain, so you must ensure that any regular expressions to match 4-byte AS numbers are written in the asplain format. If you want to change the default **show** command output to display 4-byte autonomous system numbers in the asdot format, use the **bgp asnotation dot** command under router configuration mode. When the asdot format is enabled as the default, any regular expressions to match 4-byte AS numbers must be written using the asdot format, or the regular expression match will fail. The tables below show that although you can configure 4-byte AS numbers in either asplain or asdot format, only one format is used to display **show** command output and control 4-byte AS number matching for regular expressions, and the default is asplain format. To display 4-byte AS numbers in **show** command output and to control matching for regular expressions in the asdot format, you must configure the **bgp asnotation dot** command. After enabling the **bgp asnotation dot** command, a hard reset must be initiated for all BGP sessions by entering the **clear ip bgp *** command.



Note

If you are upgrading to an image that supports 4-byte AS numbers, you can still use 2-byte AS numbers. The **show** command output and regular expression match are not changed and remain in asplain (decimal value) format for 2-byte AS numbers regardless of the format configured for 4-byte AS numbers.

Table 2: Default Asplain 4-Byte AS Number Format

Format	Configuration Format	Show Command Output and Regular Expression Match Format
asplain	2-byte: 1 to 65535 4-byte: 65536 to 4294967295	2-byte: 1 to 65535 4-byte: 65536 to 4294967295
asdot	2-byte: 1 to 65535 4-byte: 1.0 to 65535.65535	2-byte: 1 to 65535 4-byte: 65536 to 4294967295

Table 3: Asdot 4-Byte AS Number Format

Format	Configuration Format	Show Command Output and Regular Expression Match Format
asplain	2-byte: 1 to 65535 4-byte: 65536 to 4294967295	2-byte: 1 to 65535 4-byte: 1.0 to 65535.65535
asdot	2-byte: 1 to 65535 4-byte: 1.0 to 65535.65535	2-byte: 1 to 65535 4-byte: 1.0 to 65535.65535

Reserved and Private AS Numbers

In Cisco IOS XE Release 2.3 and later releases, the Cisco implementation of BGP supports RFC 4893. RFC 4893 was developed to allow BGP to support a gradual transition from 2-byte AS numbers to 4-byte AS numbers. A new reserved (private) AS number, 23456, was created by RFC 4893 and this number cannot be configured as an AS number in the Cisco IOS CLI.

RFC 5398, *Autonomous System (AS) Number Reservation for Documentation Use*, describes new reserved AS numbers for documentation purposes. Use of the reserved numbers allow configuration examples to be accurately documented and avoids conflict with production networks if these configurations are literally copied. The reserved numbers are documented in the IANA AS number registry. Reserved 2-byte AS numbers are in the contiguous block, 64496 to 64511 and reserved 4-byte AS numbers are from 65536 to 65551 inclusive.

Private 2-byte AS numbers are still valid in the range from 64512 to 65534 with 65535 being reserved for special use. Private AS numbers can be used for internal routing domains but must be translated for traffic that is routed out to the Internet. BGP should not be configured to advertise private AS numbers to external networks. Cisco IOS software does not remove private AS numbers from routing updates by default. We recommend that ISPs filter private AS numbers.



Note

AS number assignment for public and private networks is governed by the IANA. For information about AS numbers, including reserved number assignment, or to apply to register an AS number, see the following URL: <http://www.iana.org/>.

Cisco Implementation of 4-Byte Autonomous System Numbers

In Cisco IOS XE Release 2.4 and later releases, the Cisco implementation of 4-byte autonomous system (AS) numbers uses asplain—65538, for example—as the default regular expression match and output display format for AS numbers, but you can configure 4-byte AS numbers in both the asplain format and the asdot format as described in RFC 5396. To change the default regular expression match and output display of 4-byte AS numbers to asdot format, use the **bgp asnotation dot** command followed by the **clear ip bgp *** command to perform a hard reset of all current BGP sessions. For more details about 4-byte AS number formats, see the “BGP Autonomous System Number Formats” section.

In Cisco IOS XE Release 2.3, the Cisco implementation of 4-byte AS numbers uses asdot—1.2, for example—as the only configuration format, regular expression match, and output display, with no asplain support. For an example of BGP peers in two autonomous systems using 4-byte numbers, see the figure below. To view a configuration example of the configuration between three neighbor peers in separate 4-byte autonomous systems configured using asdot notation, see the “Example: Configuring a BGP Routing Process and Peers Using 4-Byte Autonomous System Numbers” section.

Cisco also supports RFC 4893, which was developed to allow BGP to support a gradual transition from 2-byte AS numbers to 4-byte AS numbers. To ensure a smooth transition, we recommend that all BGP speakers within an AS that is identified using a 4-byte AS number be upgraded to support 4-byte AS numbers.



Note

A new private AS number, 23456, was created by RFC 4893, and this number cannot be configured as an AS number in the Cisco IOS CLI.

Figure 1: BGP Peers in Two Autonomous Systems Using 4-Byte Numbers

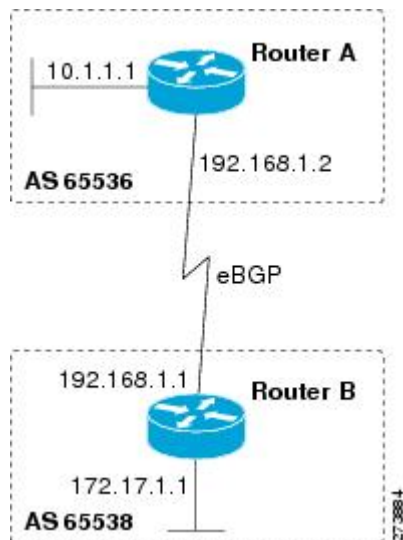

How to Configure BGP Support for 4-byte ASN

Configuring a BGP Routing Process and Peers Using 4-Byte Autonomous System Numbers

Perform this task to configure a Border Gateway Protocol (BGP) routing process and BGP peers when the BGP peers are located in an autonomous system (AS) that uses 4-byte AS numbers. The address family configured here is the default IPv4 unicast address family, and the configuration is done at Router B in the figure above (in the “Cisco Implementation of 4-Byte Autonomous System Numbers” section). The 4-byte AS numbers in this task are formatted in the default asplain (decimal value) format; for example, Router B is in AS number 65538 in the figure above. Remember to perform this task for any neighbor routers that are to be BGP peers.

Before You Begin



Note

By default, neighbors that are defined using the **neighbor remote-as** command in router configuration mode exchange only IPv4 unicast address prefixes. To exchange other address prefix types, such as IPv6 prefixes, neighbors must also be activated using the **neighbor activate** command in address family configuration mode for the other prefix types.

SUMMARY STEPS

1. **enable**
2. **configure terminal**
3. **router bgp** *autonomous-system-number*
4. **neighbor** *ip-address* **remote-as** *autonomous-system-number*
5. Repeat Step 4 to define other BGP neighbors, as required.
6. **address-family ipv4** [**unicast** | **multicast** | **vrf** *vrf-name*]
7. **neighbor** *ip-address* **activate**
8. Repeat Step 7 to activate other BGP neighbors, as required.
9. **network** *network-number* [**mask** *network-mask*] [**route-map** *route-map-name*]
10. **end**
11. **show ip bgp** [*network*] [*network-mask*]
12. **show ip bgp summary**

DETAILED STEPS

	Command or Action	Purpose
Step 1	enable	Enables privileged EXEC mode.

	Command or Action	Purpose
	<p>Example:</p> <pre>Device> enable</pre>	<ul style="list-style-type: none"> Enter your password if prompted.
Step 2	<p>configure terminal</p> <p>Example:</p> <pre>Device# configure terminal</pre>	Enters global configuration mode.
Step 3	<p>router bgp <i>autonomous-system-number</i></p> <p>Example:</p> <pre>Device(config)# router bgp 65538</pre>	<p>Enters router configuration mode for the specified routing process.</p> <ul style="list-style-type: none"> In this example, the 4-byte AS number, 65538, is defined in asplain notation.
Step 4	<p>neighbor <i>ip-address</i> remote-as <i>autonomous-system-number</i></p> <p>Example:</p> <pre>Device(config-router)# neighbor 192.168.1.2 remote-as 65536</pre>	<p>Adds the IP address of the neighbor in the specified AS to the IPv4 multiprotocol BGP neighbor table of the local device.</p> <ul style="list-style-type: none"> In this example, the 4-byte AS number, 65536, is defined in asplain notation.
Step 5	Repeat Step 4 to define other BGP neighbors, as required.	--
Step 6	<p>address-family ipv4 [unicast multicast vrf <i>vrf-name</i>]</p> <p>Example:</p> <pre>Device(config-router)# address-family ipv4 unicast</pre>	<p>Specifies the IPv4 address family and enters address family configuration mode.</p> <ul style="list-style-type: none"> The unicast keyword specifies the IPv4 unicast address family. By default, the device is placed in configuration mode for the IPv4 unicast address family if the unicast keyword is not specified with the address-family ipv4 command. The multicast keyword specifies IPv4 multicast address prefixes. The vrf keyword and <i>vrf-name</i> argument specify the name of the virtual routing and forwarding (VRF) instance to associate with subsequent IPv4 address family configuration mode commands.
Step 7	<p>neighbor <i>ip-address</i> activate</p> <p>Example:</p> <pre>Device(config-router-af)# neighbor 192.168.1.2 activate</pre>	Enables the neighbor to exchange prefixes for the IPv4 unicast address family with the local device.

	Command or Action	Purpose
Step 8	Repeat Step 7 to activate other BGP neighbors, as required.	--
Step 9	network <i>network-number</i> [mask <i>network-mask</i>] [route-map <i>route-map-name</i>] Example: Device(config-router-af)# network 172.17.1.0 mask 255.255.255.0	(Optional) Specifies a network as local to this AS and adds it to the BGP routing table. <ul style="list-style-type: none"> For exterior protocols the network command controls which networks are advertised. Interior protocols use the network command to determine where to send updates.
Step 10	end Example: Device(config-router-af)# end	Exits address family configuration mode and returns to privileged EXEC mode.
Step 11	show ip bgp [<i>network</i>] [<i>network-mask</i>] Example: Device# show ip bgp 10.1.1.0	(Optional) Displays the entries in the BGP routing table. Note Only the syntax applicable to this task is used in this example. For more details, see the <i>Cisco IOS IP Routing: BGP Command Reference</i> .
Step 12	show ip bgp summary Example: Device# show ip bgp summary	(Optional) Displays the status of all BGP connections.

Examples

The following output from the **show ip bgp** command at Router B shows the BGP routing table entry for network 10.1.1.0 learned from the BGP neighbor at 192.168.1.2 in Router A in the figure above with its 4-byte AS number of 65536 displayed in the default asplain format.

```
RouterB# show ip bgp 10.1.1.0
BGP routing table entry for 10.1.1.0/24, version 2
Paths: (1 available, best #1)
  Advertised to update-groups:
    2
  65536
    192.168.1.2 from 192.168.1.2 (10.1.1.99)
      Origin IGP, metric 0, localpref 100, valid, external, best
```

The following output from the **show ip bgp summary** command shows the 4-byte AS number 65536 for the BGP neighbor 192.168.1.2 of Router A in the figure above after this task has been configured on Router B:

```
RouterB# show ip bgp summary
BGP router identifier 172.17.1.99, local AS number 65538
BGP table version is 3, main routing table version 3
2 network entries using 234 bytes of memory
2 path entries using 104 bytes of memory
```

```

3/2 BGP path/bestpath attribute entries using 444 bytes of memory
1 BGP AS-PATH entries using 24 bytes of memory
0 BGP route-map cache entries using 0 bytes of memory
0 BGP filter-list cache entries using 0 bytes of memory
BGP using 806 total bytes of memory
BGP activity 2/0 prefixes, 2/0 paths, scan interval 60 secs
Neighbor      V      AS MsgRcvd MsgSent  TblVer  InQ  OutQ  Up/Down  Stated
192.168.1.2   4      65536    6      6       3    0    0 00:01:33    1

```

Troubleshooting Tips

Use the **ping** command to verify basic network connectivity between the BGP devices.

Modifying the Default Output and Regular Expression Match Format for 4-Byte Autonomous System Numbers

Perform this task to modify the default output format for 4-byte autonomous system (AS) numbers from asplain format to asdot notation format. The **show ip bgp summary** command is used to display the changes in output format for the 4-byte AS numbers.

SUMMARY STEPS

1. **enable**
2. **show ip bgp summary**
3. **configure terminal**
4. **router bgp** *autonomous-system-number*
5. **bgp asnotation dot**
6. **end**
7. **clear ip bgp ***
8. **show ip bgp summary**
9. **show ip bgp regexp** *regexp*
10. **configure terminal**
11. **router bgp** *autonomous-system-number*
12. **no bgp asnotation dot**
13. **end**
14. **clear ip bgp ***

DETAILED STEPS

	Command or Action	Purpose
Step 1	enable Example: Device> enable	Enables privileged EXEC mode. <ul style="list-style-type: none"> • Enter your password if prompted.

	Command or Action	Purpose
Step 2	show ip bgp summary Example: Device# show ip bgp summary	Displays the status of all Border Gateway Protocol (BGP) connections.
Step 3	configure terminal Example: Device# configure terminal	Enters global configuration mode.
Step 4	router bgp <i>autonomous-system-number</i> Example: Device(config)# router bgp 65538	Enters router configuration mode for the specified routing process. <ul style="list-style-type: none"> In this example, the 4-byte AS number, 65538, is defined in asplain notation.
Step 5	bgp asnotation dot Example: Device(config-router)# bgp asnotation dot	Changes the default output format of BGP 4-byte AS numbers from asplain (decimal values) to dot notation. <p>Note 4-byte AS numbers can be configured using either asplain format or asdot format. This command affects only the output displayed for show commands or the matching of regular expressions.</p>
Step 6	end Example: Device(config-router)# end	Exits address family configuration mode and returns to privileged EXEC mode.
Step 7	clear ip bgp * Example: Device# clear ip bgp *	Clears and resets all current BGP sessions. <ul style="list-style-type: none"> In this example, a hard reset is performed to ensure that the 4-byte AS number format change is reflected in all BGP sessions. <p>Note Only the syntax applicable to this task is used in this example. For more details, see the <i>Cisco IOS IP Routing: BGP Command Reference</i>.</p>
Step 8	show ip bgp summary Example: Device# show ip bgp summary	Displays the status of all BGP connections.
Step 9	show ip bgp regexp <i>regexp</i> Example: Device# show ip bgp regexp ^1\.0\$	Displays routes that match the AS path regular expression. <ul style="list-style-type: none"> In this example, a regular expression to match a 4-byte AS path is configured using asdot format.

	Command or Action	Purpose
Step 10	configure terminal Example: Device# configure terminal	Enters global configuration mode.
Step 11	router bgp <i>autonomous-system-number</i> Example: Device(config)# router bgp 65538	Enters router configuration mode for the specified routing process. <ul style="list-style-type: none"> • In this example, the 4-byte AS number, 65538, is defined in asplain notation.
Step 12	no bgp asnotation dot Example: Device(config-router)# no bgp asnotation dot	Resets the default output format of BGP 4-byte AS numbers back to asplain (decimal values). Note 4-byte AS numbers can be configured using either asplain format or asdot format. This command affects only the output displayed for show commands or the matching of regular expressions.
Step 13	end Example: Device(config-router)# end	Exits router configuration mode and returns to privileged EXEC mode.
Step 14	clear ip bgp * Example: Device# clear ip bgp *	Clears and resets all current BGP sessions. <ul style="list-style-type: none"> • In this example, a hard reset is performed to ensure that the 4-byte AS number format change is reflected in all BGP sessions. Note Only the syntax applicable to this task is used in this example. For more details, see the <i>Cisco IOS IP Routing: BGP Command Reference</i> .

Examples

The following output from the **show ip bgp summary** command shows the default asplain format of the 4-byte AS numbers. Note the asplain format of the 4-byte AS numbers, 65536 and 65550.

```
Router# show ip bgp summary
```

```
BGP router identifier 172.17.1.99, local AS number 65538
BGP table version is 1, main routing table version 1
Neighbor      V      AS MsgRcvd MsgSent  TblVer  InQ  OutQ  Up/Down  Statd
192.168.1.2   4      65536    7      7        1    0    0 00:03:04    0
192.168.3.2   4      65550    4      4        1    0    0 00:00:15    0
```

After the **bgp asnotation dot** command is configured (followed by the **clear ip bgp *** command to perform a hard reset of all current BGP sessions), the output is converted to asdot notation format as shown in the

following output from the **show ip bgp summary** command. Note the asdot format of the 4-byte AS numbers, 1.0 and 1.14 (these are the asdot conversions of the 65536 and 65550 AS numbers).

```
Router# show ip bgp summary

BGP router identifier 172.17.1.99, local AS number 1.2
BGP table version is 1, main routing table version 1
Neighbor      V      AS MsgRcvd MsgSent   TblVer   InQ  OutQ  Up/Down  Statd
192.168.1.2   4        1.0      9       9         1     0     0 00:04:13    0
192.168.3.2   4        1.14     6       6         1     0     0 00:01:24    0
```

After the **bgp asnotation dot** command is configured (followed by the **clear ip bgp *** command to perform a hard reset of all current BGP sessions), the regular expression match format for 4-byte AS paths is changed to asdot notation format. Although a 4-byte AS number can be configured in a regular expression using either asplain format or asdot format, only 4-byte AS numbers configured using the current default format are matched. In the first example below, the **show ip bgp regexp** command is configured with a 4-byte AS number in asplain format. The match fails because the default format is currently asdot format and there is no output. In the second example using asdot format, the match passes and the information about the 4-byte AS path is shown using the asdot notation.



Note

The asdot notation uses a period, which is a special character in Cisco regular expressions. To remove the special meaning, use a backslash before the period.

```
Router# show ip bgp regexp ^65536$

Router# show ip bgp regexp ^1\.0$

BGP table version is 2, local router ID is 172.17.1.99
Status codes: s suppressed, d damped, h history, * valid, > best, i - internal,
               r RIB-failure, S Stale
Origin codes: i - IGP, e - EGP, ? - incomplete
   Network        Next Hop           Metric LocPrf Weight Path
*> 10.1.1.0/24    192.168.1.2         0             0 1.0 i
```

Configuration Examples for BGP Support for 4-byte ASN

Examples: Configuring a BGP Routing Process and Peers Using 4-Byte Autonomous System Numbers

Asplain Format

The following example shows the configuration for Router A, Router B, and Router E in the figure below with a Border Gateway Protocol (BGP) process configured between three neighbor peers (at Router A, at

Router B, and at Router E) in separate 4-byte autonomous systems configured using asplain notation. IPv4 unicast routes are exchanged with all peers.

Figure 2: BGP Peers Using 4-Byte Autonomous System Numbers in Asplain Format

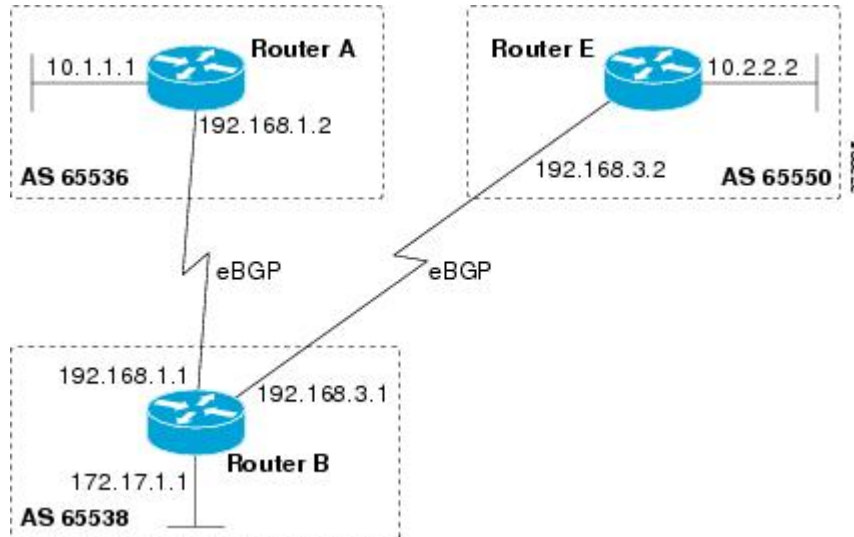

Router A

```
router bgp 65536
  bgp router-id 10.1.1.99
  no bgp default ipv4-unicast
  bgp fast-external-fallover
  bgp log-neighbor-changes
  timers bgp 70 120
  neighbor 192.168.1.1 remote-as 65538
  !
  address-family ipv4
    neighbor 192.168.1.1 activate
    no auto-summary
    no synchronization
    network 10.1.1.0 mask 255.255.255.0
  exit-address-family
```

Router B

```
router bgp 65538
  bgp router-id 172.17.1.99
  no bgp default ipv4-unicast
  bgp fast-external-fallover
  bgp log-neighbor-changes
  timers bgp 70 120
  neighbor 192.168.1.2 remote-as 65536
  neighbor 192.168.3.2 remote-as 65550
  neighbor 192.168.3.2 description finance
  !
  address-family ipv4
    neighbor 192.168.1.2 activate
    neighbor 192.168.3.2 activate
    no auto-summary
    no synchronization
    network 172.17.1.0 mask 255.255.255.0
  exit-address-family
```

Router E

```

router bgp 65550
  bgp router-id 10.2.2.99
  no bgp default ipv4-unicast
  bgp fast-external-fallover
  bgp log-neighbor-changes
  timers bgp 70 120
  neighbor 192.168.3.1 remote-as 65538
  !
  address-family ipv4
    neighbor 192.168.3.1 activate
    no auto-summary
    no synchronization
    network 10.2.2.0 mask 255.255.255.0
  exit-address-family

```

Asdot Format

The following example shows how to create the configuration for Router A, Router B, and Router E in the figure below with a BGP process configured between three neighbor peers (at Router A, at Router B, and at Router E) in separate 4-byte autonomous systems configured using the default asdot format. IPv4 unicast routes are exchanged with all peers.

Figure 3: BGP Peers Using 4-Byte Autonomous System Numbers in Asdot Format

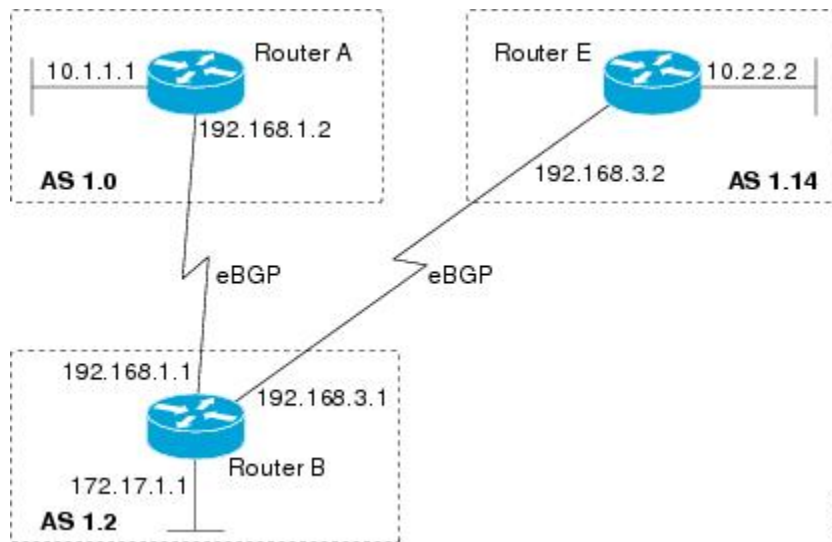
**Router A**

```

router bgp 1.0
  bgp router-id 10.1.1.99
  no bgp default ipv4-unicast
  bgp fast-external-fallover
  bgp log-neighbor-changes
  timers bgp 70 120
  neighbor 192.168.1.1 remote-as 1.2
  !
  address-family ipv4
    neighbor 192.168.1.1 activate
    no auto-summary
    no synchronization

```

```
network 10.1.1.0 mask 255.255.255.0
exit-address-family
```

Router B

```
router bgp 1.2
  bgp router-id 172.17.1.99
  no bgp default ipv4-unicast
  bgp fast-external-fallover
  bgp log-neighbor-changes
  timers bgp 70 120
  neighbor 192.168.1.2 remote-as 1.0
  neighbor 192.168.3.2 remote-as 1.14
  neighbor 192.168.3.2 description finance
  !
  address-family ipv4
    neighbor 192.168.1.2 activate
    neighbor 192.168.3.2 activate
    no auto-summary
    no synchronization
    network 172.17.1.0 mask 255.255.255.0
  exit-address-family
```

Router E

```
router bgp 1.14
  bgp router-id 10.2.2.99
  no bgp default ipv4-unicast
  bgp fast-external-fallover
  bgp log-neighbor-changes
  timers bgp 70 120
  neighbor 192.168.3.1 remote-as 1.2
  !
  address-family ipv4
    neighbor 192.168.3.1 activate
    no auto-summary
    no synchronization
    network 10.2.2.0 mask 255.255.255.0
  exit-address-family
```

Examples: Configuring a VRF and Setting an Extended Community Using a BGP 4-Byte Autonomous System Number

Asplain Default Format in Cisco IOS Release 12.0(32)SY8, 12.0(33)S3, 12.2(33)SRE, 12.2(33)SX11, and Later Releases

The following example is available in Cisco IOS Release 12.0(32)SY8, 12.0(33)S3, 12.2(33)SRE, 12.2(33)XNE, 12.2(33)SX11, and later releases and shows how to create a VRF with a route target that uses a 4-byte autonomous system number, 65537, and how to set the route target to extended community value 65537:100 for routes that are permitted by the route map:

```
ip vrf vpn_red
  rd 64500:100
  route-target both 65537:100
  exit
route-map red_map permit 10
  set extcommunity rt 65537:100
end
```

After the configuration is completed, use the **show route-map** command to verify that the extended community is set to the route target that contains the 4-byte autonomous system number of 65537:

```
RouterB# show route-map red_map
route-map red_map, permit, sequence 10
  Match clauses:
  Set clauses:
    extended community RT:65537:100
  Policy routing matches: 0 packets, 0 bytes
```

4-Byte Autonomous System Number RD Support

The following example shows how to create a VRF with a route distinguisher that contains a 4-byte AS number 65536, and a route target that contains a 4-byte autonomous system number, 65537:

```
ip vrf vpn_red
 rd 65536:100
 route-target both 65537:100
 exit
```

After the configuration is completed, use the **show vrf** command to verify that the 4-byte AS number route distinguisher is set to 65536:100:

```
RouterB# show vrf vpn_red
Current configuration : 36 bytes
vrf definition x
 rd 65536:100
!
```

Asdot Default Format in Cisco IOS Release 12.0(32)S12, and 12.4(24)T

The following example is available in Cisco IOS Release 12.0(32)S12, and 12.4(24)T and shows how to create a VRF with a route target that uses a 4-byte autonomous system number, 1.1, and how to set the route target to the extended community value 1.1:100 for routes that are permitted by the route map.



Note

In Cisco IOS Release 12.0(32)SY8, 12.0(33)S3, 12.2(33)SX11, and later releases, this example works if you have configured asdot as the default display format using the **bgp asnotation dot** command.

```
ip vrf vpn_red
 rd 64500:100
 route-target both 1.1:100
 exit
route-map red_map permit 10
 set extcommunity rt 1.1:100
 end
```

After the configuration is completed, use the **show route-map** command to verify that the extended community is set to the route target that contains the 4-byte autonomous system number of 1.1.

```
RouterB# show route-map red_map
route-map red_map, permit, sequence 10
  Match clauses:
  Set clauses:
    extended community RT:1.1:100
  Policy routing matches: 0 packets, 0 bytes
```

Asdot Default Format for 4-Byte Autonomous System Number RD Support

The following example works if you have configured asdot as the default display format using the **bgp asnotation dot** command:

```
ip vrf vpn_red
 rd 1.0:100
 route-target both 1.1:100
 exit
```

Additional References for BGP Support for 4-byte ASN

Related Documents

Related Topic	Document Title
Cisco IOS commands	Cisco IOS Master Command List, All Releases
BGP commands	Cisco IOS IP Routing: BGP Command Reference

Standards and RFCs

Standard/RFC	Title
RFC 4893	<i>BGP Support for Four-octet AS Number Space</i>
RFC 5396	<i>Textual Representation of Autonomous System (AS) Numbers</i>
RFC 5398	<i>Autonomous System (AS) Number Reservation for Documentation Use</i>
RFC 5668	<i>4-Octet AS Specific BGP Extended Community</i>

Technical Assistance

Description	Link
The Cisco Support and Documentation website provides online resources to download documentation, software, and tools. Use these resources to install and configure the software and to troubleshoot and resolve technical issues with Cisco products and technologies. Access to most tools on the Cisco Support and Documentation website requires a Cisco.com user ID and password.	http://www.cisco.com/cisco/web/support/index.html

Feature Information for BGP Support for 4-byte ASN

The following table provides release information about the feature or features described in this module. This table lists only the software release that introduced support for a given feature in a given software release train. Unless noted otherwise, subsequent releases of that software release train also support that feature.

Use Cisco Feature Navigator to find information about platform support and Cisco software image support. To access Cisco Feature Navigator, go to www.cisco.com/go/cfn. An account on Cisco.com is not required.

Table 4: Feature Information for BGP Support for 4-byte ASN

Feature Name	Releases	Feature Information
BGP Support for 4-byte ASN	12.0(32)S12 12.0(33)S3 12.2(33)SRE 15.0(1)S	The BGP Support for 4-Byte ASN feature introduced support for 4-byte autonomous system numbers. The following commands were introduced or modified: bgp asnotation dot , bgp confederation identifier , bgp confederation peers , all clear ip bgp commands that configure an autonomous system number, ip as-path access-list , ip extcommunity-list , match source-protocol , neighbor local-as , neighbor remote-as , redistribute (IP) , router bgp , route-target , set as-path , set extcommunity , set origin , all show ip bgp commands that display an autonomous system number, and show ip extcommunity-list .
BGP—4-Byte ASN RD and RT Support	15.4(3)S	The BGP Support for 4-Byte ASN RD and RT support for 4-byte autonomous system numbers was added.

