

Cisco Nexus Dashboard Fabric Controller Release Notes

Release 12.1.2e

Note: Cisco Data Center Network Manager (DCNM) is renamed as Cisco Nexus Dashboard Fabric Controller (NDFC) from Release 12.0.1a.

The documentation set for this product strives to use bias-free language. For this documentation set, bias-free is defined as language that does not imply discrimination based on age, disability, gender, racial identity, ethnic identity, sexual orientation, socioeconomic status, and intersectionality. Exceptions may be present in the documentation due to language that is hardcoded in the user interfaces of the product software, language used based on RFP documentation or language that is used by a referenced third-party product.

Overview

Cisco Nexus Dashboard Fabric Controller is the comprehensive management solution for all NX-OS deployments spanning LAN Fabric, SAN, and IP Fabric for Media (IPFM) networks in data centers powered by Cisco. Cisco Nexus Dashboard Fabric Controller also supports other devices, such as IOS-XE switches, IOS-XR routers, and non-Cisco devices. Being a multi-fabric controller, Cisco Nexus Dashboard Fabric Controller manages multiple deployment models like VXLAN EVPN, Classic 3-Tier, FabricPath, and Routed Fabrics for LAN while providing ready-to-use control, management, monitoring, and automation capabilities. In addition, Cisco NDFC when enabled as a SAN Controller automates Cisco MDS Switches and Cisco Nexus Family infrastructure in NX-OS mode with a focus on storage-specific features and analytics.

Cisco Nexus Dashboard Fabric Controller Release Notes describes the features, bugs, and limitations for Cisco Nexus Dashboard Fabric Controller. For more information about this product, see <https://www.cisco.com/c/en/us/support/cloud-systems-management/nexus-dashboard-fabric-controller-12/model.html>.

Nexus Dashboard Fabric Controller focuses on Control and Management for three primary market segments:

- LAN including VXLAN, Multi-Site, Classic Ethernet, and External Fabrics supporting Cisco Nexus switches with NX-OS, additional support for IOS-XR, IOS-XE, and adjacent Host, Compute, Virtual Machine, and Container Management systems.
- SAN for Cisco MDS and Cisco Nexus switches with NX-OS, including support for integration with storage arrays and additionally Host, and Virtual Machine systems.
- Media Control for Multicast Video production networks using Cisco Nexus switches operated as standalone NX-OS, with additional integrations for 3rd party media control systems.

Cisco Nexus Dashboard Fabric Controller, Release 12 is available as an application running exclusively on top of the Cisco Nexus Dashboard Virtual or Physical Appliance.

Virtual Nexus Dashboard deployment with OVA is also referred to as virtual Nexus Dashboard (vND) deployment, while the deployment of Nexus Dashboard on physical appliance (Service Engine) is known as physical Nexus Dashboard (pND) deployment. To deploy Nexus Dashboard based on your requirement, refer to [Cisco Nexus Dashboard Deployment Guide](#).

Beginning with Release 12, Cisco Nexus Dashboard Fabric Controller has a single installation mode. Post-installation, it supports selection from multiple personas at run-time. After the Nexus Dashboard Fabric Controller Release 12.1.2e is installed, you can choose from one of the following personas:

- **Fabric Discovery**—discover, monitor, and visualize LAN deployments.
- **Fabric Controller**—LAN Controller for Classic Ethernet (vPC), Routed, VXLAN, Multi-Site, and IP Fabric for Media Deployments.
- **SAN Controller**—SAN Controller for MDS and Nexus switches with SAN Insights.

All features/services are modularized, broken into smaller microservices, and the required microservices are orchestrated based on the feature set or feature selections. If any microservice or feature experiences a disruption, only that specific microservice is restarted and recovered, minimizing disruption to the overall system.

In contrast to the previous DCNM Active-Standby HA model, Cisco NDFC introduces Active-Active HA deployment model utilizing all three nodes in a cluster for deploying microservices. This is a significant improvement in both latency and effective resource utilization.

For more information, see [Cisco Nexus Dashboard Fabric Controller \(Formerly DCNM\)](#).

NDFC Release 12.1.2e supports Nexus Dashboard Orchestrator (NDO) based hybrid cloud solution that offers seamless connectivity between on-premises and cloud networks. This solution uses NDFC to manage on-premises VXLAN-based fabric and on-premises IPN devices (such as Cisco Catalyst 8000V, Cisco ASR 1000, and so on), for optional IPSec connectivity. Cloud sites (AWS or Microsoft Azure) are managed by Cloud Network Controller. NDO service is used to orchestrate connectivity between on-premises and cloud sites, and between two or more cloud sites. VXLAN is used to build overlay tunnels between the sites with BGP EVPN as the control plane of choice and an optional IPSec tunnel from on-premises to cloud routers, for additional security. For more information, see [Hybrid Cloud Connectivity Deployment for Cisco NX-OS](#).

Change History

Date	Description
31 January 2023	Release 12.1.2e became available.

Deployment Options

The following deployment options are available for Cisco Nexus Dashboard Fabric Controller:

- NDFC on Single node (non-HA Cluster)

On Single node Nexus Dashboard, you can deploy NDFC with the following personas:

- Fabric Discovery for lab/non-production environments (<= 25 switches)
- Fabric Controller for lab/non-production environments (<= 25 switches)
- Fabric Controller in IP Fabric for Media controller mode for production environments
- SAN Controller for production environments (<= 80 switches) with or without SAN Insights

Note: Fabric Controller/Fabric Discovery deployment is for Lab purposes only. Do not deploy this in your production environment.

- NDFC on a 3-node virtual (vND) or physical (pND) Nexus Dashboard Cluster (Active-Active HA mode)

On 3-Node Nexus Dashboard, you can deploy NDFC with the following personas:

- Fabric Discovery
- Fabric Controller
- SAN Controller with or without SAN Insights
- NDFC on a 5-node virtual Nexus Dashboard (vND) Cluster (Active-Active HA mode)

On 5-Node Nexus Dashboard, you can deploy NDFC with the following personas:

- Fabric Discovery
- Fabric Controller
- On a 4-node or 5-node Nexus Dashboard, you can deploy Nexus Dashboard Insights (NDI) along with NDFC with the following personas:
 - NDI and NDFC in Fabric Discovery persona (NDFC-Monitored mode) – 4 pND nodes
 - NDI and NDFC in Fabric Controller persona (NDFC-Managed mode) – 5 pND nodes
- NDFC on a Nexus Dashboard running on Red Hat Enterprise Linux (RHEL)

On a 1-node or 3-node Nexus Dashboard on the RHEL server, you can deploy NDFC with the SAN Controller with or without SAN Insights

- NDFC on a virtual Nexus Dashboard (vND) with KVM hypervisor

On a 1-node or 3-node Nexus Dashboard, you can enable Fabric Controller, Fabric Discovery, or SAN Controller personas.

Refer to [Nexus Dashboard Capacity Planning](#) to determine the number of switches supported for each deployment. For information about NDFC Scale enhancements, see [Verified Scalability Guide for Cisco Nexus Dashboard Fabric Controller](#).

In the 3-node and 5-node deployment, there are three Nexus Dashboard master nodes. In the 5-node deployment, the additional 2 nodes serve as worker nodes. The 3-node or 5-node cluster deployment is an active-active solution, that is, all nodes are utilized to run micro-services of Nexus Dashboard Fabric Controller. When a node fails, microservices being executed on the node, are moved to the other nodes. Nexus Dashboard Fabric Controller functions normally in a one-node failure scenario. However, it is expected that there will be a brief disruption to services that must be migrated on node failure. After the migration of services is complete, the supported scale will continue to be supported but at degraded performance. For optimal NDFC performance, a system with one failed node is not desirable and must be rectified at the earliest. If two Master nodes fail, the 3-node or 5-node cluster cannot tolerate the failure and all NDFC services will be disrupted.

Cohosting of NDFC-Managed mode with Nexus Dashboard Insights (NDI)

Starting Release 12.1.1e, you can host NDFC and Nexus Dashboard Insights on the same Nexus Dashboard cluster in Managed mode to manage fabrics and Nexus Dashboard Insights to monitor the same fabrics. In Fabric Discovery mode, NDI on the same Nexus Dashboard cluster is supported from NDFC Release 12.0.2f. This requires 4 physical Nexus Dashboard nodes for a maximum scale of up to 50 switches. This functionality is also supported on NDFC Release 12.1.1e with the paired Nexus Dashboard Insights release.

Note: Nexus Dashboard deployed on KVM does not support cohosting NDFC and NDI on the same Nexus Dashboard cluster.

Note: For cohosting NDFC and NDI on the same Nexus Dashboard cluster, Nexus Dashboard nodes must be Layer 2 adjacent. Support for Layer 3 adjacency for cohosted deployments will be introduced in upcoming releases.

The following table shows the compatible versions for Nexus Dashboard and services.

Services	Compatible Version
Nexus Dashboard	2.3.2d
Nexus Dashboard Fabric Controller	12.1.2e

The following table shows the supported scale for NDFC and NDI cohosted on the same Nexus Dashboard Cluster.

Specification	Supported Scale
Number of physical Nexus Dashboard nodes	5
Number of switches supported	50
Number of flows supported in Nexus Dashboard Insights	10000

For information about the supported scale for NDFC one Nexus Dashboard Cluster, and Insights and Orchestrator services on a different Nexus Dashboard Cluster, see [Verified Scalability Limits for Nexus Dashboard Insights](#).

Deployment Profile Simplification

Nexus Dashboard deployment profile simplification is intended to help streamline the onboarding of services against a given deployment scale and relieve the task of remembering the cross-connect of deployments.

Beginning with Cisco Nexus Dashboard Release 2.2.1h, resource profile selection has been reduced to several more intuitive parameters directly related to your deployment use case. These parameters, such as the number of switches or flows describe the fabric size and use case intent and allow the cluster to intelligently determine the resources needed for the service. The parameters are categorized as **Network Scale**.

NDFC selects an appropriate profile from among the predefined set of profiles to match the scale.

Note: You must restart the services on the Nexus Dashboard after modifying the network scale parameters.

To view or modify the Network Scale parameters on Cisco Nexus Dashboard, perform the following steps:

1. Choose Nexus Dashboard > Cluster Configuration > Network Scale.
2. Click the edit icon to modify the network scale parameters.
3. In the **Number of Sites** field, provide the target number of sites for your deployment that this Nexus Dashboard cluster manages.
4. In the **Number of Switches** field, provide the target number of switch nodes for your deployment.

5. In the **Flows per second** field, provide the target number of flows for LAN/IPFM/SAN-Insights deployments or scale that is supported by NDFC and Nexus Dashboard Insights cohosted setup.

The deployment profiles in NDFC Release 12.1.2e use a different naming convention for these deployment profiles which is more in line with the scale numbers that each profile supports.

On the fresh install of Nexus Dashboard, the “Network Scale” is empty. We recommend that you define the number of sites, switches, and flows per second in the Network Scale. In such a scenario, the service selects a default profile based on the number of cluster nodes.

If the available cluster compute capacity is less than the desired Network Scale, Cisco NDFC installation displays an error. You must resolve the network scale values on Nexus Dashboard and proceed to install NDFC. Note that the recommendations specified in the error message provide useful suggestions about remedial action.

Nexus Dashboard assigns profile names for supported scale values with NDFC Release 12.1.2e. For validated scale numbers, refer to [Cisco NDFC Verified Scalability, Release 12.1.2e](#).

When you upgrade to NDFC 12.1.2e, the individual containers are restarted and the newly spawned 12.1.2e containers start with new resource requests and limit values.

Layer-3 Reachability between Cluster Nodes

From Release 12.1.2e, NDFC can be deployed as a service on Nexus Dashboard with Layer 3 adjacent nodes. A sample NDFC Layer3 adjacent Physical Connectivity topology is shown in the following image.

When using Layer 3 adjacency between the Nexus Dashboard nodes on which the NDFC service is running, the persistent IP addresses are advertised using the Nexus Dashboard Data or Fabric interface. The Layer 3 Persistent IP subnet pool must be unique and will be advertised to the fabric using BGP on Nexus Dashboard. Cisco NDFC container pods, such as EPL/SNMP Trap/SCP that requires Persistent IPs, are advertised as /32 BGP entries with the next hop of Nexus Dashboard Data Interface. Also, the BGP session between the Nexus Dashboard node and the uplink switches must be configured using directly connected links.

To deploy Layer 3 cluster connectivity, Nexus Dashboard nodes use BGP local and remote autonomous system configuration, along with Data Network gateway of the node to establish eBGP sessions with neighboring routers over the Data interface. As Nexus Dashboard nodes use gateway IPs to establish sessions, the neighboring BGP peers must be Layer 2 adjacent. Peers without Layer 2 adjacent connectivity are not supported. You must configure the BGP network correctly to ensure that the Nexus Dashboard routes are transmitted correctly.

Nexus Dashboard uses BGP session to publish /32 routes for reaching NDFC features using external IPs obtained from the Persistent IP subnet. If a node or network fails, the external IPs are not reachable until recovery is complete (if the network can recover itself).

NDFC L3 Adjacency Physical Connectivity

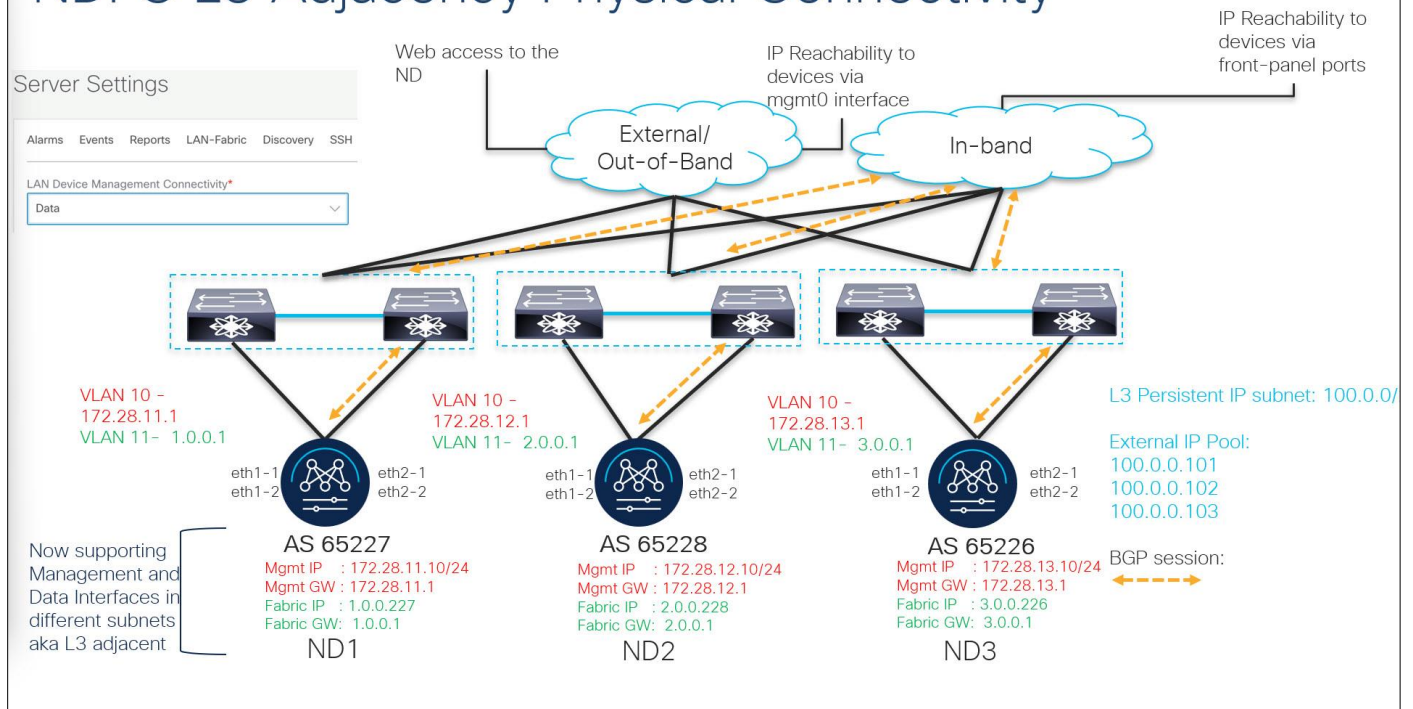

Upgrade or modification from an existing Layer-2 adjacent Nexus Dashboard cluster to a Layer-3 adjacent cluster is not supported. When using Layer 3 adjacency, NDFC service is supported only when the switch connectivity is through the Nexus Dashboard Data interface. Choose **NDFC UI > Settings > Admin** tab. From the **LAN Device Management Connectivity** drop-down list, select **Data**.

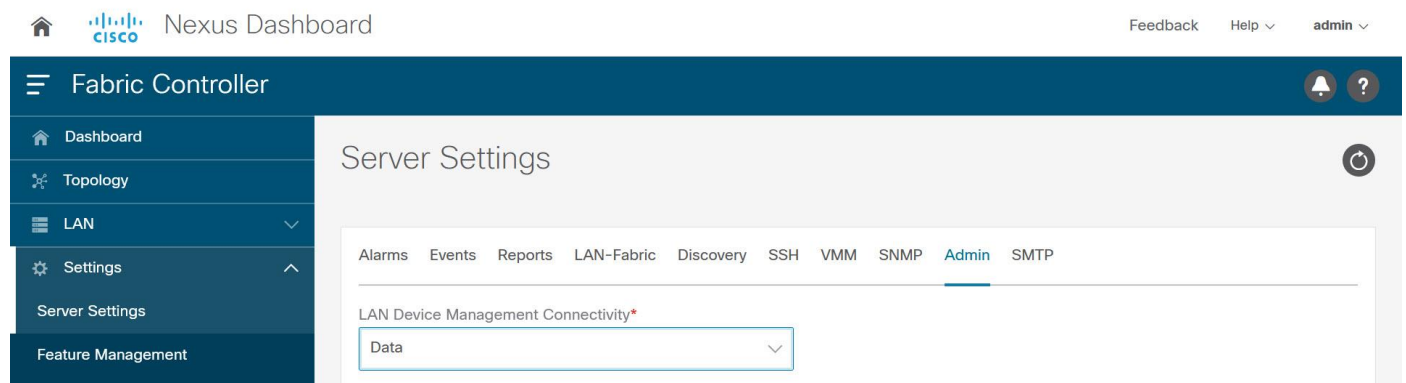

The following table provides information about different scenarios about Layer 3 adjacent cluster nodes connectivity.

Network details	Support provided
Modify or upgrade from Layer 2 adjacency to Layer 3 adjacency	Not supported; redeploy cluster if necessary
Modify or upgrade from Layer 3 adjacency to Layer 2 adjacency	Not supported; redeploy cluster if necessary

Network details	Support provided
NDFC to Switch connectivity over the Management interface	Supported (The traffic initiated by the switch to NDFC is routed via the Data Interface)
NDFC to Switch connectivity over Data interface	Supported
Nexus Dashboard BGP traffic over Nexus Dashboard Management interface	Not supported
Nexus Dashboard BGP traffic over Nexus Dashboard Data interface	Supported
Nexus Dashboard BGP peer L2-Adjacent	Supported
Nexus Dashboard BGP peer L3-Adjacent	Not supported

Refer to [Cisco Nexus Dashboard User Guide, Release 2.2.x](#) for more information.

System Requirements

This chapter lists the tested and supported hardware and software specifications for Cisco Nexus Dashboard Fabric Controller architecture. The application is in English locales only.

The following sections describe the various system requirements for the proper functioning of your Cisco Nexus Dashboard Fabric Controller, Release 12.1.2e.

Note: We recommend that you do not upgrade any underlying third-party software separately. All the necessary software components will be updated during the inline upgrade procedure. Upgrading the components outside of the Nexus Dashboard Fabric Controller causes functionality issues.

Cisco Nexus Dashboard Version Compatibility

Cisco Nexus Dashboard Fabric Controller (NDFC) requires Nexus Dashboard version 2.3.1c or higher. If you try to upload NDFC 12.1.2e on a Nexus Dashboard version earlier than 2.3.1c, you will not be allowed to upload the application. To download the correct version of Nexus Dashboard, visit [Software Download - Nexus Dashboard](#).

Nexus Dashboard Server Resource (CPU/Memory) Requirements

The following table provides information about Server Resource (CPU/Memory) Requirements to run NDFC on top of Nexus Dashboard. Refer to [Nexus Dashboard Capacity Planning](#) to determine the number of switches supported for each deployment.

Cisco Nexus Dashboard can be deployed using number of different form factors. NDFC can be deployed on the following form factors:

- pND - Physical Nexus Dashboard
- vND - Virtual Nexus Dashboard
- rND - RHEL Nexus Dashboard

Table 1. Server Resource (CPU/Memory) Requirements to run NDFC on top of Nexus Dashboard

Management Interface	Node Type	CPUs	Memory	Storage (Throughput: 40-50MB/s)
Fabric Discovery	Virtual Node (vND) – app OVA	16vCPUs	64GB	550GB SSD
	Physical Node (pND) (PID: SE-NODE-G2 and ND-NODE-L4T)	2 x 10-core 2.2G Intel Xeon Silver CPU	256 GB of RAM	4 x 2.4TB HDDs 400GB SSD 1.2TB NVME drive
Fabric Controller	Virtual Node (vND) – app OVA	16vCPUs	64GB	550GB SSD
	Physical Node (pND) (PID: SE-NODE-G2 and ND-NODE-L4T)	2 x 10-core 2.2G Intel Xeon Silver CPU	256 GB of RAM	4 x 2.4TB HDDs 400GB SSD 1.2TB NVME drive
SAN Controller	Virtual Node (vND) – app OVA (without SAN Insights)	16vCPUs (with physical reservation)	64GB (with physical reservation)	550GB SSD
	App Node (rND) (without SAN Insights)	16vCPUs (with physical reservation)	64GB (with physical reservation)	550GB SSD
	Data Node (vND) – Data OVA (with SAN Insights)	32vCPUs (with physical reservation)	128GB (with physical reservation)	3TB SSD
	Data Node (rND) (with SAN Insights)	32vCPUs (with physical reservation)	128GB (with physical reservation)	3TB SSD
	Physical Node (pND) (PID: SE-NODE-G2 and ND-NODE-L4T)	2x 10-core 2.2G Intel Xeon Silver CPU	256 GB of RAM	4x 2.4TB HDDs 400GB SSD 1.2TB NVME drive

Nexus Dashboard Networks

When first configuring Nexus Dashboard, on every node, you must provide two IP addresses for the two Nexus Dashboard interfaces—one connected to the Data Network and the other to the Management Network. The data network is typically used for the nodes' clustering and north-south connectivity to the physical network. The management network typically connects to the Cisco Nexus Dashboard Web UI, CLI, or API.

For enabling the Nexus Dashboard Fabric Controller, the Management and Data Interfaces on a Nexus Dashboard node must be in different subnets. Different nodes that belong to the same Nexus Dashboard cluster can either be Layer-2 adjacent or Layer-3 adjacent. For more information, see [Layer-3 Reachability between Cluster Nodes](#).

Connectivity between the Nexus Dashboard nodes is required on both networks with the round trip time (RTT) not exceeding 50ms. Other applications running on the same Nexus Dashboard cluster may have lower RTT requirements and you must always use the lowest RTT requirement when deploying multiple applications in the same Nexus Dashboard cluster. For more information, see [Cisco Nexus Dashboard Deployment Guide](#).

The following table provides information about network requirements for NDFC on Nexus Dashboard.

Management Interface	Data Interface	Persistent IPs
Layer 2 adjacent	Layer 2 adjacent	<p>One of the following for LAN:</p> <ul style="list-style-type: none"> • If using default LAN Device Management Connectivity (set to Management): <ul style="list-style-type: none"> ◦ 2 IPs in management network for SNMP/Syslog and SCP services ◦ Plus one IP per fabric for EPL (if enabled) in data network ◦ Plus one IP for Telemetry receiver in management network if IP Fabric for Media is enabled • If LAN Device Management Connectivity is set to Data: <ul style="list-style-type: none"> ◦ 2 IPs in data network for SNMP/Syslog and SCP services ◦ Plus one IP per fabric for EPL (if enabled) in data network ◦ Plus one IP for Telemetry receiver in data network if IP Fabric for Media is enabled <p>For SAN:</p> <ul style="list-style-type: none"> • 2 IPs in data network for SNMP/Syslog and SCP services • Plus one IP per Nexus Dashboard node in data network if SAN Insights receivers is enabled
Layer 3 adjacent	Layer 3 adjacent	<p>For LAN:</p> <ul style="list-style-type: none"> • LAN Device Management Connectivity on NDFC must be set to Data • 2 IPs for SNMP/Syslog and SCP/POAP services • Plus one IP per fabric for EPL <p>These IPs must be part of a subnet that is different from Nexus Dashboard management and Nexus Dashboard data subnets associated with any of Nexus Dashboard nodes. These IPs must belong to the Layer-3 External Persistent Service Pool.</p> <p>Note: SAN Controller and IP Fabric for Media modes are not supported in this deployment.</p>

Supported Latency

As Cisco Nexus Dashboard Fabric Controller is deployed atop Cisco Nexus Dashboard, the latency factor depends on Cisco Nexus Dashboard. See [Cisco Nexus Dashboard Deployment Guide](#) for information about latency.

Supported Web Browsers

Cisco Nexus Dashboard Fabric Controller is supported on the following Web browsers:

- Google Chrome version 109.0.5414.87 (64 bit)
- Microsoft Edge version 109.0.1518.61 (64 bit)
- Mozilla Firefox version 108.0.1 (64 bit)

Other Supported Software

The following table lists the other software that is supported by Cisco Nexus Dashboard Fabric Controller Release 12.1.2e.

Component	Features
Security	<ul style="list-style-type: none">• ACS versions 4.0, 5.1, 5.5, and 5.8• ISE version 2.6• ISE version 3.0• Telnet Disabled: SSH Version 1, SSH Version 2, Global Enforce SNMP Privacy Encryption.• Web Client: HTTPS with TLS 1, 1.1, 1.2, and 1.3

New Software Features

The following sections include information about the new features, enhancements, and hardware support introduced in the Cisco Nexus Dashboard Fabric Controller, Release 12.1.2e.

Preview Features

The following preview features are available in Cisco NDFC Release 12.1.2e for Fabric Controller persona.

Product Impact	Features	Description
Ease of Use	Private VLAN support for VXLAN EVPN fabrics	NDFC can now be used to easily provision private-VLANs in a Data Center VXLAN EVPN fabric. The overlay network deployment workflow has been enhanced to support flexible provisioning of primary and secondary VLANs on appropriate VTEPs. All provisioning options supported for the private-VLAN feature on NX-OS, are available in NDFC.
	Enhanced Classic LAN Fabric support	A new fabric has been introduced for automated provisioning of 3-tier Access-Aggregation-Core related vPC deployments. This includes easy provisioning of FHRP and VRF Lite connectivity on the Aggregation-Core tiers. Current support is for greenfield deployments of Nexus 7000 and 9000 switches. The LAN Classic, Enhanced Classic, and External Connectivity Network fabrics can be part of a Fabric Group.

Common Enhancements to all Personas

The following features are new in Cisco NDFC Release 12.1.2e for all personas in Cisco Nexus Dashboard Fabric Controller.

Product Impact	Features	Description
Ease of Use	Disable Promiscuous mode for virtual Nexus Dashboard (vND) deployments	From Release 12.1.2e, you can disable promiscuous mode on port groups associated with the vND management and data interface vNICs. All features that use persistent IP will continue to work even for Layer-2 adjacent vND deployments.
	Elasticsearch to Open Search database	From Release 12.1.2e, NDFC uses an OpenSearch database for storing time series data. As part of the upgrade process from prior NDFC releases, data is seamlessly migrated from Elasticsearch to OpenSearch.
	Inline Backup Restore	This feature enables you to perform a config-only restore on an existing NDFC system using a prior backup. The backup itself may be a full backup or a config-only backup. In prior releases, a restore from a backup file, could only be performed on a freshly installed NDFC, with no persona enabled. Now you can also restore the backup on an In-Service system where some persona has already been enabled.
Interoperability	NDFC with Nexus Dashboard QCOW2 deployments on KVM hypervisor on RHEL Release 8.6	NDFC can be installed on a virtual Nexus Dashboard cluster running on top of KVM hypervisor running on top of CentOS and RHEL operating systems. All 3 personas namely, Fabric Controller, Fabric Discovery, and SAN Controller are supported. For more information about deploying a cluster, see Cisco Nexus Dashboard Deployment Guide .
Performance and Scalability	Resource Utilization for MinIO and CockroachDB	NDFC Release 12.1.2e uses CockroachDB which is a distributed SQL database primarily for configuration data. It uses MinIO as an object store for storing blob files like switch images, patches, and so on. Both CockroachDB and MinIO export statistics that are collected and made available on Nexus Dashboard Web UI > Infrastructure > Resource Utilization , dashboards namely, CockroachDB and Minio Overview .
Licensing	NDFC Licensing for 3rd Party Devices	NDFC licenses for 3rd party devices will be supported in the DCN 3rd Party Essentials License tier. Customers can now purchase the DCN 3rd Party Essentials for Arista devices onboarded into NDFC.

Fabric Controller Enhancements

The following features are new in Cisco NDFC Release 12.1.2e for the Fabric Controller.

Product Impact	Feature	Description
Ease of Use	Configuring IP Prefix list	IP Prefix lists allow route filtering and/or redistribution of routes that are exchanged between routing domains. A prefix list contains one or more IPv4 or IPv6 network prefixes, the associated prefix length values, and various matching parameters. NDFC now allows users to create and manage IP prefix lists natively using pre-packaged best-practices prefix list templates.

Product Impact	Feature	Description
	Configuring Native VLAN for ethernet interfaces without using freeform configuration	This feature allows you to configure native VLAN for trunk interfaces. A Native VLAN field has been added to the int_trunk_host template to allow users to set the field directly.
	Interface Group Support with Policy Inheritance	NDFC 12.1.2e allows you to now optionally associate a shared interface policy with an Interface Group. The same shared policy is automatically inherited by all the interfaces that are members of a given interface group. This functionality is currently supported for Ethernet trunk interfaces.
	Interface group support for Layer-2 ToRs	The Interface Group functionality has been extended to allow ToR switch trunk interfaces along with the leaf trunk interfaces, as members. This allows for easy deployment of overlay networks across any kind of leaf-ToR VXLAN EVPN deployments.
	Secure POAP	NDFC now allows touchless Day-0 bring-up of Nexus 9000 devices via secure POAP using HTTPs. To support interoperability scenarios, NDFC can simultaneously support POAP with some switches using the traditional HTTP transport option versus POAP for other switches using the secure HTTPS transport option.
	Support for additional DHCP relay servers for overlay networks	NDFC 12.1.2e supports a maximum of 16 DHCP relay servers for overlay networks in Data Center VXLAN EVPN fabrics.
	Support to specify and honor pre-provisioned links	Additional parameters such as MTU, speed, and so on, are introduced with the existing pre-provisioned link template that provisions planned fabric links in Data Center VXLAN EVPN fabrics. These parameters are preserved during subsequent Recalculate & Deploy after the device has completed bootstrap.
Interoperability	Hybrid Cloud Connectivity	NDFC now provides hybrid cloud connectivity of VXLAN EVPN on-premises fabrics to the public cloud (AWS or Azure). NDFC also provisions the IPsec IPN devices (ASR 1000, Catalyst 8000V and so on) on the on-premises side. The public cloud connectivity is managed via the Cloud Network Controller. Nexus Dashboard Orchestrator is used to orchestrate connectivity between on-premises and cloud sites via the NDFC and CNC respectively. VXLAN over an optional IPsec tunnel is used as the data plane while BGP EVPN is used as the control plane.

Product Impact	Feature	Description
Performance and Scalability	Scale Enhancements	<p>The following enhancements are introduced with Release 12.1.2e:</p> <ul style="list-style-type: none"> • Support for 500 switches in Easy Fabrics (Data Center VXLAN EVPN and BGP Fabrics) and 1000 switches in External Fabrics (Flexible Network fabrics, Classic LAN fabrics, External Connectivity Network fabrics, and Multi-Site Interconnect Network fabrics) • Supports 200 switches per fabric. • Enhanced VNI Scale (2500 Layer-2 only Networks or 500 VRFs and 2000 Layer-3 Networks), 4K Networks (VNIs) on a single switch. <p>For more information, see Cisco NDFC Verified Scalability Guide.</p>

Fabric Controller with IP Fabric for Media (IPFM) Enhancements

The following features are new in Cisco NDFC Release 12.1.2e for the Fabric Controller with IP Fabric for Media (IPFM).

Product Impact	Feature	Description
Performance and Scalability	PTP monitoring in scaled deployments	This feature provides flexibility to enable or disable notifications when the system encounters high volume of correction events. By default, high correction notification is disabled. You can also configure the frequency for generating notifications.
Ease of Use	Dynamic allocation of host port IPs using defined switch level pool	NDFC allows you to export the selected interfaces with different types of policies. However, you can import many interfaces with the same policy, at one go.
Performance and Scalability	RTP flow monitoring enhancement	From Release 12.1.2e, a new hyperlink is introduced to switches in RTP/EDI Flow Monitor > Active Flows to view end-to-end flow topology for each fabric. If there are multiple receivers, you can choose a receiver from the Select Receiver drop-down list to view the topology for that receiver.
Performance and Scalability	NBM mode support changes in default and user-defined VRFs	Release 12.1.2e allows configuring and monitoring of both NBM active and passive VRFs in IPFM fabrics.

SAN Controller Enhancements

The following features are new in Cisco Nexus Dashboard Fabric Controller Release 12.1.2e for the SAN Controller.

Product Impact	Feature	Description
Interoperability	Support for NDFC with Nexus Dashboard on RHEL 8.6	From Release 12.1.2e, NDFC is supported with Nexus Dashboard deployed on Red Hat Enterprise Linux (RHEL) 8.6 version. NDFC SAN Controller is supported with without SAN Insights.
Performance and Scalability	Enhancements to SAN Insights	<ul style="list-style-type: none"> Enhanced scale supports up to 1M ITLs/ITNs. You can modify, activate, or utilize data of SAN Insights anomaly policies which are in inactive state. VM information from VMware vCenter discovery is combined with SAN Insight Data to provide end-to-end visibility from VM to LUNs.
Ease of Use	Enhancements to Zoning	<ul style="list-style-type: none"> From Release 12.1.2e, you can click Topology icon next to the Zone name to view Zone Topology. The topology is displayed in a hierarchical left-right layout by default. A column is introduced to display the port status.
Ease of Use	FC Name Server	Name Server stores name entries for all hosts in the FCNS database. The Name Server tab displays name server entries for the selected Fabric. Note that this data is pulled from the Switches discovery, and therefore, the duplicate entries are removed.
Ease of Use	DIRL Congestion management enhancements	<ul style="list-style-type: none"> From Release 12.1.2e, DIRL is supported with NPV switches also. DIRL specifies the interface on which the analysis is collected. You can view the trend, which provides information about Ingress, Egress, DIRL counter(s) values of the current DIRL with event timestamps for the selected DIRL interface.
Ease of Use	Host and Storage Dashboard display discovery source information	On the Host and Storage Dashboards, a new icon is introduced next to the host name and storage name that displays the type of discovery. It displays if the enclosure is from a VMware vCenter or storage or FC discovery.
Ease of Use	Configuration Drift	A new monitoring job is executed daily to check for differences in baseline configuration and current configuration. Configuration Drift feature displays Yes when there is a difference between baseline and current configuration and an appropriate alarm is raised.

Product Impact	Feature	Description
Ease of Use	UCS discovery	From Release 12.1.2e, NDFC allows you to discover switches using UCS credentials.

New Hardware Features

The following new hardware is supported with Cisco Nexus Dashboard Fabric Controller Release 12.1.2e.

- N35-T-48X - Cisco Nexus 3550-T switch
- N9K-C9808 - Cisco Nexus 9800 Series 8 Slot Chassis switch
- N9K-C9348D-GX2A - Cisco Nexus 9348D-GX2A Switch with 48p 400/100-Gbps QSFP-DD ports and 2p 1/10 SFP+ ports
- N9K-C9408 - 4RU 8-slot LEM-based modular Cisco Nexus 9408 switch
- DS-C9124V-K9 - Cisco MDS 9124V 64-Gbps 24-Port Fibre Channel Switch
- DS-C9148V-K9 - Cisco MDS 9148V 64-Gbps 48-Port Fibre Channel Switch

Upgrade Paths

The following table summarizes the type of upgrade that you must follow to upgrade to Release 12.1.2e.

Go to [Software Download](#) to download the Upgrade Tool scripts.

Current Release Number	Deployment Type	Upgrade process when upgrading to Release 12.1.2e
12.1.1e	All	Upgrade Nexus Dashboard version to 2.3.1 Upgrade NDFC application to 12.1.2e
12.0.2f	All	Upgrade Nexus Dashboard version 2.1.1e to version 2.3.1 Upgrade NDFC application to 12.1.2e.
12.0.1a	All	Direct upgrade is not supported.
11.5(4)	All	Backup using DCNM_To_NDFC_Upgrade_Tool_LIN_WIN.zip Restore on Nexus Dashboard Fabric Controller Web UI > Operations > Backup & Restore

Supported Cisco Platforms and Software Versions

The compatibility matrix provides information regarding the compatibility of Cisco Nexus Dashboard Fabric Controller Release 12.1.2e with various switches, applications, and other devices. See [Cisco NDFC Compatibility Matrix, Release 12.1.2e](#).

You supported hardware platforms and software versions, see [Compatibility Matrix for Cisco NDFC](#).

Cisco Nexus Dashboard and Services compatibility information for specific Cisco Nexus Dashboard, services, and fabric versions. See [Cisco Nexus Dashboard and Services Compatibility Matrix](#).

For recommendation on Nexus Dashboard cluster sizing for cohosting services, see the [Nexus Dashboard Capacity Planning tool](#).

Supported Non-Nexus and Non-Cisco Platforms

You supported hardware platforms and software versions, see [Compatibility Matrix for Cisco NDFC](#).

Supported Non-Nexus Devices

- Cisco ASR 1001-X
- Cisco ASR 1002-HX
- Cisco ASR-9001
- Cisco Catalyst 8000V, 8200, 8300, 8500 series routers
- Cisco Catalyst 9300-48U
- Cisco Catalyst 9300-24T
- Cisco Catalyst 9300-48P
- Cisco Catalyst 9500-48YC
- Cisco Catalyst 9500-32C
- Cisco CSR 1000v
- Cisco NCS 5501
- Cisco 8000 series routers
- Arista DCS-7050SX3-48YC12

Supported IBM Directors and Switches

- IBM SAN16C-R 8977-R16 SAN Switch Extension Switch
- IBM SAN32C-6 8977-T32 32X32G FC SAN Switch
- IBM SAN48C-6 8977-T48 48X32G FC SAN Switch
- IBM SAN50C-R 8977-R50 50-Port SAN Extension Switch
- IBM SAN96C-6 8977-T96 96X32G FC SAN Switch
- IBM SAN192C-6 8978-E04 (4 Module) SAN Director
- IBM SAN384C-6 8978-E08 (8 Module) SAN Director
- IBM SAN768C-6 8978-E16 (16 Module) SAN Director

Resolved Issues

The following table lists the Open bugs for Cisco Nexus Dashboard Fabric Controller, Release 12.1.2e. Click the bug ID to access the Bug Search Tool and see additional information about the bug.

Identifier	Headline
CSCvz49031	SAN: Archive failure reasons are not reported

Identifier	Headline
CSCvz73651	Rep: Programmable Report for performance failed with no error details on SAN setup
CSCwa84457	Scale Longevity: Memory leak on Java built in HTTP client lib. - NDFC ISSU Wizard will fail
CSCwb13035	NDFC12.1 : hyperlink in e-mail report does not redirect to the statistics view
CSCwb20987	San insights dashboard page taking 2 mins to load with 500k itl/itn
CSCwb54083	NDFC Sanity: Pending config for VRF Lite Deployment between two CAT9K
CSCwb57420	After upgrade VRFs edit without any change moves the vrf to pending state
CSCwb62482	[MSG Scale] power off one node (pnd2) and config status changed to NA for many switches
CSCwb73342	NDFC server setting to Data from mgmt, disable and reenable NDFC has POAP container is not running
CSCwb80045	Deploy of one network changes status of other pending nw to deployed for interface attach/detach
CSCwb84876	[ipfm_easyfabric] failed to load data on running recalculate config
CSCwb90993	Automation - Upgrade ND Only-Compliance call failed. Error connecting to App
CSCwb94545	When RBAC user has only DashboardUser for All domain with MSD fabrics tab UI is broken
CSCwb94757	NDFC Sanity: Serial Number of Stack Wise Config switch is incorrect
CSCwb96335	Gray area is not shown for the vPC with MCTless
CSCwb96429	Replacement device's links are all red in the topology after completing manual RMA
CSCwb98046	CLI Mode: Edit vrf from NDO seen as pending on the ndfc
CSCwe21853	After upgrade if older version of NDFC is deleted, NDFC will not come up if at least 2 nodes reboot Note: This bug is resolved for Nexus Dashboard release 2.3.2b and later but remains open for Nexus Dashboard release 2.3.1c.
CSCwc02069	Easy Fabric: 'Unshut Host Interfaces by Default' does not take effect for preserve config = no
CSCwc02779	Deploy failure on BGW for L3 networks when fabric is in CLI mode
CSCwc06397	Topology for Host enclosures is not getting displayed for scale fabrics

Open Issues

The following table lists the Open bugs for Cisco Nexus Dashboard Fabric Controller, Release 12.1.2e. Click the bug ID to access the Bug Search Tool and see additional information about the caveat.

Identifier	Headline
CSCwb80045	Deploy of one network changes status of other pending nw to deployed for interface attach/detach
CSCwd86943	[MSG Scale] power off one node (pnd2) and config status changed to NA for many switches

Identifier	Headline
CSCwd95598	Network Export failed to save " dhcpServers" fields properly
CSCwd98202	Longevity: telemetry-syncn status API failing on flows/RTP flow monitoring page
CSCwe00204	API output is getting truncated for allowed vlan list
CSCwe05045	[LAN]: Action menu items for events under fabric overview and switch overview are greyed out
CSCwe12223	IPFM Longevity: CDB pod reset 137
CSCwe12281	Quick detach of network with IG on leaf and tor interfaces deployed
CSCwe21895	Navigating to NDFC URL in browser address is reaching ND-OneView after sign-in - bookmarks fail
CSCwe52834	Error message in fabric setting page states to enable promiscuous mode

Known Issues

Bug ID	Description	Exists in
CSCwd85885	Network creation error on upgraded setup.	12.0.1a
CSCwd84563	Upgrade to v2.3 from v2.1.2d - No warning messages to disable old App/containers.	Nexus Dashboard Release 2.1.2d
CSCwf66965	After the upgrade to release 12.1.2e, the default VRF is no longer deployed.	12.1.1
CSCwh62924	vCenter Visualization plugin crash when VMware DVS configured with PVLAN.	Releases prior to 12.1.3b

Related Content

Navigating the Cisco Nexus Dashboard Fabric Controller Documentation

This document describes and provides links to the user documentation available for Cisco Nexus Dashboard Fabric Controller. To find a document online, use one of the links in this section.

Document Title	Description
Cisco Nexus Dashboard Fabric Controller Documentation Roadmap, Release 12.1.2e	Describes and provides links to the user documentation available for Cisco Nexus Dashboard Fabric Controller.
Cisco Nexus Dashboard Fabric Controller Compatibility Matrix, Release 12.1.2e	Lists the Cisco Nexus and the Cisco MDS platforms and their software releases that are compatible with Cisco Nexus Dashboard Fabric Controller.
Verified Scalability Guide for Cisco Nexus Dashboard Fabric Controller, Release 12.1.2e	Lists the supported scalability parameters for Cisco Nexus Dashboard Fabric Controller.

Document Title	Description
Cisco Nexus Dashboard Fabric Controller Configuration Guides	<p>These configuration guides provide conceptual and procedural information on the Cisco Nexus Dashboard Fabric Controller Web GUI.</p> <ul style="list-style-type: none"> • Cisco NDFC-Fabric Controller Configuration Guide, Release 12.1.2e • Cisco NDFC-SAN Controller Configuration Guide, Release 12.1.2e
Cisco Nexus Dashboard Fabric Controller Configuration Examples and TechNotes	<p>These documents guide you to deploy various solutions and use-cases using NDFC.</p>
Cisco Nexus Dashboard Fabric Controller Installation Guide, Release 12.1.2e	<p>These documents guide you to plan your requirements and deployment of the Cisco Nexus Dashboard Fabric Controller.</p>
Cisco Nexus Dashboard Fabric Controller Software Upgrade Matrix	<p>Lists the software upgrade paths that are supported for Cisco Nexus Dashboard Fabric Controller.</p>
Cisco Nexus Dashboard Fabric Controller Open Source Licensing, Release 12.1.2e	<p>Provides information about the Cisco Nexus Dashboard Fabric Controller Open-Source Licensing Information.</p>
Cisco Nexus Dashboard Fabric Controller REST APIs on DevNet	<p>Provides REST APIs that allow third parties to test and develop application software. The REST API documentation is packaged with the product and can be accessed through any browser.</p> <ul style="list-style-type: none"> • Nexus Dashboard Fabric Controller (LAN) API • Nexus Dashboard Fabric Controller (SAN) API

Platform-Specific Documents

The documentation set for platform-specific documents that Cisco Nexus Dashboard Fabric Controller manages includes the following:

Cisco Nexus 2000 Series Fabric Extender Documentation

<https://www.cisco.com/c/en/us/products/switches/nexus-2000-series-fabric-extenders/index.html>

Cisco Nexus 3000 Series Switch Documentation

<https://www.cisco.com/c/en/us/support/switches/nexus-3000-series-switches/series.html>

Cisco Nexus 4000 Series Switch Documentation

<https://www.cisco.com/c/en/us/support/switches/nexus-4000-series-switches/series.html>

Cisco Nexus 5000 Series Switch Documentation

<https://www.cisco.com/c/en/us/support/switches/nexus-5000-series-switches/series.html>

Cisco Nexus 6000 Series Switch Documentation

<https://www.cisco.com/c/en/us/support/switches/nexus-6000-series-switches/series.html>

Cisco Nexus 7000 Series Switch Documentation

<https://www.cisco.com/c/en/us/support/switches/nexus-7000-series-switches/series.html>

Cisco Nexus 9000 Series Switch Documentation

<https://www.cisco.com/c/en/us/support/switches/nexus-9000-series-switches/series.html>

Nexus Dashboard and Services Documentation

- [Cisco Nexus Dashboard Release Notes](#)
- [Cisco Nexus Dashboard Orchestrator Release Notes](#)
- [Cisco Nexus Dashboard Insights Release Notes](#)
- [Cisco Nexus Dashboard Capacity Planning](#)
- [Cisco Nexus Dashboard and Services Compatibility Matrix](#)

Documentation Feedback

To provide technical feedback on this document, or to report an error or omission, please send your comments to: ndfc-docfeedback@cisco.com.

You can also use the feedback form available in the right pane of every online document. We appreciate your feedback.

Legal Information

Cisco and the Cisco logo are trademarks or registered trademarks of Cisco and/or its affiliates in the U.S. and other countries. To view a list of Cisco trademarks, go to this URL:

<https://www.cisco.com/c/en/us/about/legal/trademarks.html>. Third-party trademarks mentioned are the property of their respective owners. The use of the word partner does not imply a partnership relationship between Cisco and any other company. (1721R)

Any Internet Protocol (IP) addresses and phone numbers used in this document are not intended to be actual addresses and phone numbers. Any examples, command display output, network topology diagrams, and other figures included in the document are shown for illustrative purposes only. Any use of actual IP addresses or phone numbers in illustrative content is unintentional and coincidental.

© 2023 Cisco Systems, Inc. All rights reserved.