



## **Cisco MDS 9700 Series Multilayer Directors Hardware Installation Guide**

**First Published:** 2013-12-07

**Last Modified:** 2023-03-13

### **Americas Headquarters**

Cisco Systems, Inc.  
170 West Tasman Drive  
San Jose, CA 95134-1706  
USA  
<http://www.cisco.com>  
Tel: 408 526-4000  
800 553-NETS (6387)  
Fax: 408 527-0883



# CONTENTS

**Full Cisco Trademarks with Hardware License ?**

---

**PREFACE**

**Preface xi**

- Audience xi
- Document Conventions xi
- Related Documentation xii
- Communications, Services, and Additional Information xii

---

**CHAPTER 1**

**New and Changed Information 1**

- New and Changed Information 1

---

**CHAPTER 2**

**Product Overview 5**

- Cisco MDS 9718 Director 5
  - Cisco MDS 9718 Director Features 6
- Cisco MDS 9710 Director 7
  - Cisco MDS 9710 Director Features 8
- Cisco MDS 9706 Director 9
  - Cisco MDS 9706 Director Features 10
- Chassis Description 10
  - Cisco MDS 9718 Director Chassis 10
  - Cisco MDS 9710 Director Chassis 15
  - Cisco MDS 9706 Director Chassis 18
- System LEDs 21
- Supervisor Modules 21
  - Cisco MDS 9700 Series Supervisor-4 Module 21

Cisco MDS 9700 Series Supervisor-1E Module	25
Cisco MDS 9700 Series Supervisor-1 Module	28
Crossbar Fabric Switching Modules	32
Cisco MDS 9718 Director Crossbar Fabric Switching Modules	32
Cisco MDS 9710 Director Crossbar Fabric Switching Modules	34
Cisco MDS 9706 Director Crossbar Fabric Switching Modules	37
Fiber Channel Switching Modules	40
Cisco MDS 48-Port 64-Gbps Fiber Channel Switching Module	40
Cisco MDS 48-Port 32-Gbps Fiber Channel Switching Module	43
Cisco MDS 48-Port 16-Gbps Fiber Channel Switching Module	44
SAN Extension Modules	46
Cisco MDS 24/10 port SAN Extension Module	46
Fiber Channel over Ethernet Switching Modules	48
Cisco MDS 24-Port 40-Gbps Fiber Channel over Ethernet Module	49
Cisco MDS 48-Port 10-Gbps Fiber Channel over Ethernet Module	50
Fan Modules or Trays	52
Cisco MDS 9718 Director Fan Modules	53
Cisco MDS 9710 Director Fan Modules	55
Cisco MDS 9706 Director Fan Modules	56
Power Supplies	56
Supported Transceivers	59
Fiber Channel SFP+ Transceivers	59

---

**CHAPTER 3**
**Preparing the Site 61**

Humidity Requirements	61
Altitude Requirements	61
Dust and Particulate Requirements	62
Minimizing Electromagnetic and Radio Frequency Interference	62
Shock and Vibration Requirements	63
Grounding Requirements	63
Planning for Power Requirements	63
Power Modes Overview	64
Rack and Cabinet Requirements	66
General Requirements for Open Four-Post Racks	66

General Rack and Cabinet Requirements for Cisco MDS 9700 Series Directors	66
Rack and Cabinet Requirements for the Cisco MDS 9718 Chassis	67
Rack and Cabinet Requirements for the Cisco MDS 9710 Chassis	67
Rack and Cabinet Requirements for the Cisco MDS 9706 Chassis	67
Clearance Requirements for Cisco MDS 9700 Series Directors	68
Rack-Mounting Guidelines	70
Before Installing the Rack-Mount Support Brackets	70
Installing and Removing the Brackets	71
Installing the Cisco MDS 9700 Series Shelf Bracket Kit into a Rack	71
Installing the Switch on the Brackets	72
Installing the Switch on the Rack-Mount Support Brackets	72
Installing the Switch on the Shelf Brackets	73
Removing the Shelf Bracket Kit	74

---

**CHAPTER 4**

**Installing the Cisco MDS 9700 Series Switches 75**

Preparing for Installation	75
Unpacking and Inspecting the Switch	76
Required Equipments	77
Installation Guidelines	78
Attaching Bottom-Support Rails to a Two-Post Rack	79
Attaching Bottom-Support Rails to a Four-Post Rack	80
Installing the Cisco MDS 9706 Chassis in a Two-Post Rack	85
Installing the Cisco MDS 9710 and MDS 9718 Series Switch on a Four-Post Rack or Cabinet	90
Installing the Cisco MDS 9700 Series Switch on a Four-Post Rack or Cabinet	92
System Grounding	100
Proper Grounding Practices	100
Preventing Electrostatic Discharge Damage	101
Establishing the System Ground	102
Required Tools and Equipment	103

---

**CHAPTER 5**

**Connecting the Cisco MDS 9700 Series Switches 105**

Connection Guidelines	105
Preparing for Network Connections	106
Connecting to the Console Port	106

Connecting to the MGMT 10/100/1000 Ethernet Port	107
Connecting to a Fibre Channel or Fibre Channel over Ethernet (FCoE) Port	108
Removing and Installing SFP+ and QSFP+ Transceivers	108
Removing an SFP+ or QSFP+ Transceiver	109
Installing an SFP+ Transceiver	110
Removing and Installing Cables into SFP+ or QSFP+ Transceivers	111
Removing a Cable from an SFP+ or QSFP+ Transceiver	111
Installing a Cable into an SFP+ or QSFP+ Transceiver	111
Maintaining SFP+ and QSFP+ Transceivers and Fiber-Optic Cables	112

**CHAPTER 6**

<b>Installing, Removing, and Verifying Field Replaceable Units</b>	<b>115</b>
Installing a Supervisor Module	115
Removing a Supervisor Module	117
Installing a Line Card Module	119
Removing a Line Card Module	120
Upgrading Fibre Channel switching Modules (Line cards)	122
Nondisruptive Migration from Supervisor-1/1E to Supervisor-4 Modules	123
Requirements	124
Components Used	124
Guidelines and Limitations	124
Prerequisites	126
Nondisruptive Supervisor-4 Migration on Dual Supervisor Switch	129
Nondisruptive Supervisor-4 Migration on Single Supervisor Switch	136
Supervisor-4 Migration Verification	143
Supervisor-4 Migration Clean Up	147
Troubleshooting	148
Disruptive Migration from Supervisor-1/1E to Supervisor-4 Modules	153
Installing a Switching Module	158
Removing a Switching Module	159
Verifying Installation of the Supervisor and Switching Modules	159
Crossbar Fabric Switching Modules	160
Installing a Crossbar Fabric Switching Module	161
Removing a Crossbar Fabric Switching Module	165

Nondisruptive Migration from Crossbar Fabric-1 Switching Modules to Crossbar Fabric-3 Switching Modules	166
Requirements	166
Components Used	166
Prerequisites	167
Performing a Nondisruptive Migration from Crossbar Fabric-1 Switching Modules to Crossbar Fabric-3 Switching Modules	168
Verification	171
Recovery Procedure	172
Troubleshooting	172
Power Supply in a Switch Chassis	172
Installing an AC Power Supply	173
Connecting an AC Power Supply to an AC Power Source	173
Removing an AC Power Supply	175
Installing a DC Power Supply	175
Connecting a DC Power Supply Directly to DC Power Sources	176
Removing a DC Power Supply	179
Installing and Removing Fan Modules or Trays	180
Installing a Fan Module or tray	180
Removing a Fan Module or Tray	182
Powering up the Switch and Verifying the Component Installation	183
<hr/>	
<b>CHAPTER 7</b>	<b>Technical Specifications 187</b>
Switch Specifications	187
Switch Specifications for Cisco MDS 9706 Director	187
Switch Specifications for Cisco MDS 9710 Director	188
Switch Specifications for Cisco MDS 9718 Director	188
Module Specifications	189
Supervisor-4 Module Specifications	189
Supervisor-1E Module Specifications	189
Supervisor-1 Module Specifications	190
Crossbar Fabric Switching Module Specifications	190
40-Gigabit FCoE Switching Module Specifications	191
10-Gigabit FCoE Switching Module Specifications	192

10-Gigabit FCoE Switching Module Specifications	192
48-Port 64-Gbps FC Switching Module Specifications	193
48-Port 32-Gbps FC Switching Module Specifications	193
48-Port 16-Gbps FC Switching Module Specifications	194
Power Specifications	194
Power Supply Specifications — 3000-W AC Power Supply	195
Power Supply Specifications — 3500-W High Voltage AC/DC Power Supply	195
Power Supply Fuse Information	196
Component Power Requirements and Heat Dissipation	196
Power Requirements and Heat Dissipation for MDS 9710 with 3000 W AC Power Supplies and 64 Gbps Fibre Channel switching modules	198
Power Requirements and Heat Dissipation for MDS 9710 with 3000 W AC Power Supplies and 32 Gbps Fibre Channel switching modules	199
AC Power Consumption for the Cisco MDS 9706 Director	199
AC Power Consumption for the Cisco MDS 9710 Director	200
AC Power Consumption for the Cisco MDS 9718 Director	201
AC Power Supply Requirements for Grid Redundancy of Cisco MDS 9706 Director	201
AC Power Supply Requirements for Grid Redundancy of Cisco MDS 9710 Director	202
AC Power Supply Requirements for Grid Redundancy of Cisco MDS 9718 Director	203
SFP+ Transceiver Specifications	204

---

**CHAPTER 8**
**Cable and Port Specifications 205**

Cables and Adapters Provided	205
Console Port	205
Console Port Pinouts	205
Connecting the Console Port to a Computer Using the DB-25 Adapter	206
Out of Band Management 10/100/1000 Ethernet Port	206
Supported Power Cords and Plugs	208
Power Cords	208
Supported Plugs for 3000 W AC Power Supplies	208
Power Supply AC Power Cords	210

---

**CHAPTER 9**
**Site Planning and Maintenance Records 213**

Contacting Customer Service	213
-----------------------------	-----

Finding the Chassis Serial Number 213

Site Preparation Checklist 214

---

CHAPTER 10

**Accessory Kit Contents 215**

Accessory Kit Contents 215



THE SPECIFICATIONS AND INFORMATION REGARDING THE PRODUCTS IN THIS MANUAL ARE SUBJECT TO CHANGE WITHOUT NOTICE. ALL STATEMENTS, INFORMATION, AND RECOMMENDATIONS IN THIS MANUAL ARE BELIEVED TO BE ACCURATE BUT ARE PRESENTED WITHOUT WARRANTY OF ANY KIND, EXPRESS OR IMPLIED. USERS MUST TAKE FULL RESPONSIBILITY FOR THEIR APPLICATION OF ANY PRODUCTS.

THE SOFTWARE LICENSE AND LIMITED WARRANTY FOR THE ACCOMPANYING PRODUCT ARE SET FORTH IN THE INFORMATION PACKET THAT SHIPPED WITH THE PRODUCT AND ARE INCORPORATED HEREIN BY THIS REFERENCE. IF YOU ARE UNABLE TO LOCATE THE SOFTWARE LICENSE OR LIMITED WARRANTY, CONTACT YOUR CISCO REPRESENTATIVE FOR A COPY.

The following information is for FCC compliance of Class A devices: This equipment has been tested and found to comply with the limits for a Class A digital device, pursuant to part 15 of the FCC rules. These limits are designed to provide reasonable protection against harmful interference when the equipment is operated in a commercial environment. This equipment generates, uses, and can radiate radio-frequency energy and, if not installed and used in accordance with the instruction manual, may cause harmful interference to radio communications. Operation of this equipment in a residential area is likely to cause harmful interference, in which case users will be required to correct the interference at their own expense.

The following information is for FCC compliance of Class B devices: This equipment has been tested and found to comply with the limits for a Class B digital device, pursuant to part 15 of the FCC rules. These limits are designed to provide reasonable protection against harmful interference in a residential installation. This equipment generates, uses and can radiate radio frequency energy and, if not installed and used in accordance with the instructions, may cause harmful interference to radio communications. However, there is no guarantee that interference will not occur in a particular installation. If the equipment causes interference to radio or television reception, which can be determined by turning the equipment off and on, users are encouraged to try to correct the interference by using one or more of the following measures:

- Reorient or relocate the receiving antenna.
- Increase the separation between the equipment and receiver.
- Connect the equipment into an outlet on a circuit different from that to which the receiver is connected.
- Consult the dealer or an experienced radio/TV technician for help.

Modifications to this product not authorized by Cisco could void the FCC approval and negate your authority to operate the product.

The Cisco implementation of TCP header compression is an adaptation of a program developed by the University of California, Berkeley (UCB) as part of UCB's public domain version of the UNIX operating system. All rights reserved. Copyright © 1981, Regents of the University of California.

NOTWITHSTANDING ANY OTHER WARRANTY HEREIN, ALL DOCUMENT FILES AND SOFTWARE OF THESE SUPPLIERS ARE PROVIDED "AS IS" WITH ALL FAULTS. CISCO AND THE ABOVE-NAMED SUPPLIERS DISCLAIM ALL WARRANTIES, EXPRESSED OR IMPLIED, INCLUDING, WITHOUT LIMITATION, THOSE OF MERCHANTABILITY, FITNESS FOR A PARTICULAR PURPOSE AND NONINFRINGEMENT OR ARISING FROM A COURSE OF DEALING, USAGE, OR TRADE PRACTICE.

IN NO EVENT SHALL CISCO OR ITS SUPPLIERS BE LIABLE FOR ANY INDIRECT, SPECIAL, CONSEQUENTIAL, OR INCIDENTAL DAMAGES, INCLUDING, WITHOUT LIMITATION, LOST PROFITS OR LOSS OR DAMAGE TO DATA ARISING OUT OF THE USE OR INABILITY TO USE THIS MANUAL, EVEN IF CISCO OR ITS SUPPLIERS HAVE BEEN ADVISED OF THE POSSIBILITY OF SUCH DAMAGES.

Any Internet Protocol (IP) addresses and phone numbers used in this document are not intended to be actual addresses and phone numbers. Any examples, command display output, network topology diagrams, and other figures included in the document are shown for illustrative purposes only. Any use of actual IP addresses or phone numbers in illustrative content is unintentional and coincidental.

All printed copies and duplicate soft copies of this document are considered uncontrolled. See the current online version for the latest version.

Cisco has more than 200 offices worldwide. Addresses and phone numbers are listed on the Cisco website at [www.cisco.com/go/offices](http://www.cisco.com/go/offices).

Cisco and the Cisco logo are trademarks or registered trademarks of Cisco and/or its affiliates in the U.S. and other countries. To view a list of Cisco trademarks, go to this URL: <https://www.cisco.com/c/en/us/about/legal/trademarks.html>. Third-party trademarks mentioned are the property of their respective owners. The use of the word partner does not imply a partnership relationship between Cisco and any other company. (1721R)

© 2013–2023 Cisco Systems, Inc. All rights reserved.





## Preface

---

This preface describes the audience, organization of, and conventions used in the Cisco MDS 9000 Series Configuration Guides. It also provides information on how to obtain related documentation, and contains the following chapters:

- [Audience, on page xi](#)
- [Document Conventions, on page xi](#)
- [Related Documentation, on page xii](#)
- [Communications, Services, and Additional Information, on page xii](#)

## Audience

To use this installation guide, you need to be familiar with electronic circuitry and wiring practices, and preferably be an electronic or electromechanical technician.

## Document Conventions

This document uses the following conventions:



---

**Note** Means *reader take note*. Notes contain helpful suggestions or references to material not covered in the manual.

---



---

**Caution** Means *reader be careful*. In this situation, you might do something that could result in equipment damage or loss of data.

---

Warnings use the following conventions:



---

**Warning** This warning symbol means danger. You are in a situation that could cause bodily injury. Before you work on any equipment, be aware of the hazards involved with electrical circuitry and be familiar with standard practices for preventing accidents. Use the statement number provided at the end of each warning to locate its translation in the translated safety warnings that accompanied this device. Statement 1071.

---

## Related Documentation

The documentation set for the Cisco MDS 9000 Series Switches includes the following documents.

### Release Notes

<http://www.cisco.com/c/en/us/support/storage-networking/mds-9000-nx-os-san-os-software/products-release-notes-list.html>

### Regulatory Compliance and Safety Information

<http://www.cisco.com/c/en/us/td/docs/switches/datacenter/mds9000/hw/regulatory/compliance/RCSI.html>

### Compatibility Information

<http://www.cisco.com/c/en/us/support/storage-networking/mds-9000-nx-os-san-os-software/products-device-support-tables-list.html>

### Installation and Upgrade

<http://www.cisco.com/c/en/us/support/storage-networking/mds-9000-nx-os-san-os-software/products-installation-guides-list.html>

### Configuration

<http://www.cisco.com/c/en/us/support/storage-networking/mds-9000-nx-os-san-os-software/products-installation-and-configuration-guides-list.html>

### CLI

<http://www.cisco.com/c/en/us/support/storage-networking/mds-9000-nx-os-san-os-software/products-command-reference-list.html>

### Troubleshooting and Reference

<http://www.cisco.com/c/en/us/support/storage-networking/mds-9000-nx-os-san-os-software/tsd-products-support-troubleshoot-and-alerts.html>

To find a document online, use the Cisco MDS NX-OS Documentation Locator at:

[http://www.cisco.com/c/en/us/td/docs/storage/san\\_switches/mds9000/roadmaps/doclocator.html](http://www.cisco.com/c/en/us/td/docs/storage/san_switches/mds9000/roadmaps/doclocator.html)

## Communications, Services, and Additional Information

- To receive timely, relevant information from Cisco, sign up at [Cisco Profile Manager](#).
- To get the business impact you're looking for with the technologies that matter, visit [Cisco Services](#).
- To submit a service request, visit [Cisco Support](#).
- To discover and browse secure, validated enterprise-class apps, products, solutions and services, visit [Cisco DevNet](#).
- To obtain general networking, training, and certification titles, visit [Cisco Press](#).
- To find warranty information for a specific product or product family, access [Cisco Warranty Finder](#).

### **Cisco Bug Search Tool**

[Cisco Bug Search Tool](#) (BST) is a web-based tool that acts as a gateway to the Cisco bug tracking system that maintains a comprehensive list of defects and vulnerabilities in Cisco products and software. BST provides you with detailed defect information about your products and software.





# CHAPTER 1

## New and Changed Information

- [New and Changed Information, on page 1](#)

### New and Changed Information

The following table lists the new and changed features available with each supported Cisco MDS NX-OS release for the Cisco MDS 9700 Series, with the latest release first.

**Table 1: Documented Features for the Cisco MDS 9700 Directors**

Feature	Description	Changed in Release	Where Documented
Reduced allocated power (reserved power) for each fan tray	The maximum power allocated to each fan tray has been reduced by optimizing the fan speed. The following switches: <ul style="list-style-type: none"> <li>• MDS 9706</li> <li>• MDS 9710</li> <li>• MDS 9718</li> </ul>	9.4(1)	<a href="#">Technical Specifications, on page 187</a>
Manageability of PSUs in MDS 9700 director switches	Support to power off unneeded PSUs in the following switches has been added: <ul style="list-style-type: none"> <li>• MDS 9706</li> <li>• MDS 9710</li> <li>• MDS 9718</li> </ul> <p>This can be used when there are PSUs in the chassis that are not used based on the power requirements of the switch. It prevents unnecessary alarms in system management software, such as NDFC.</p> <p>For more information, see the <a href="#">Cisco MDS 9000 Series Fundamentals Configuration Guide</a>.</p>	9.4(1)	<a href="#">Installing and Removing Fan Modules or Trays, on page 180</a>

Feature	Description	Changed in Release	Where Documented
Cisco MDS 48-Port 64-Gbps Fibre Channel Switching Module	The Cisco MDS 48-Port 64-Gbps Fibre Channel Switching Module (DS-X9748-3072K9) was added for Cisco MDS 9700 Series Multilayer Directors.	9.2(1)	<a href="#">Product Overview, on page 5</a>
Support for Cisco MDS 9700 Crossbar Fabric-3 Switching Module	Support for Cisco MDS 9700 Crossbar Fabric-3 Switching Module (DS-X9718-FAB3) was added for Cisco MDS 9718 Director.	8.4(2a)	<a href="#">Product Overview, on page 5</a>
Support for Cisco MDS 9700 Supervisor-4 Module	Support for Cisco MDS 9700 Supervisor-4 Module (DS-X97-SF4-K9) was added for Cisco MDS 9718 Director.	8.4(2a)	<a href="#">Product Overview, on page 5</a>
Nondisruptive Migration from a Supervisor-1E Module to a Supervisor-4 Module	Support for nondisruptive migration from a Supervisor-1E Module to Supervisor-4 Module was added for Cisco MDS 9718 Director.	8.4(2a)	<a href="#">Nondisruptive Migration from Supervisor-1/E to Supervisor-4 Modules, on page 123</a>
Nondisruptive Migration from Crossbar Fabric-1 Switching Modules to Crossbar Fabric-3 Switching Modules	Support for nondisruptive migration from Crossbar Fabric-1 Switching Modules to Crossbar Fabric-3 Switching Modules was added for Cisco MDS 9718 Director.	8.4(2a)	<a href="#">Nondisruptive Migration from Crossbar Fabric-1 Switching Modules to Crossbar Fabric-3 Switching Modules, on page 166</a>
Support for Cisco MDS 9700 Crossbar Fabric-3 Switching Module	Support for Cisco MDS 9700 Crossbar Fabric-3 Switching Module (DS-X9710-FAB3) was added for Cisco MDS 9710 Director.  Support for Cisco MDS 9700 Crossbar Fabric-3 Switching Module (DS-X9706-FAB3) was added for Cisco MDS 9706 Director.	8.4(1)	<a href="#">Product Overview, on page 5</a>
Support for Cisco MDS 9700 Supervisor-4 Module	Support for Cisco MDS 9700 Supervisor-4 Module (DS-X97-SF4-K9) was added for Cisco MDS 9710 and 9706 Directors.	8.4(1)	<a href="#">Product Overview, on page 5</a>
Nondisruptive Migration from a Supervisor-1 Module to a Supervisor-4 Module	Support for nondisruptive migration from a Supervisor-1 Module to Supervisor-4 Module was added for Cisco MDS 9710 and 9706 Directors.	8.4(1)	<a href="#">Nondisruptive Migration from Supervisor-1/E to Supervisor-4 Modules, on page 123</a>
Nondisruptive Migration from Crossbar Fabric-1 Switching Modules to Crossbar Fabric-3 Switching Modules	Support for nondisruptive migration from Crossbar Fabric-1 Switching Modules to Crossbar Fabric-3 Switching Modules was added for Cisco MDS 9710 and 9706 Directors.	8.4(1)	<a href="#">Nondisruptive Migration from Crossbar Fabric-1 Switching Modules to Crossbar Fabric-3 Switching Modules, on page 166</a>



Feature	Description	Changed in Release	Where Documented
Support for Cisco MDS 9700 HVDC PSU (DS-CHV-3.5KW)	Support for Cisco MDS 9700 HVDC PSU (DS-CHV-3.5KW) was added.	8.1(1b)	<a href="#">Product Overview, on page 5</a>
Cisco MDS 48-Port 32-Gbps Fibre Channel Switching Module	The Cisco MDS 48-Port 32-Gbps Fibre Channel Switching Module is supported on Cisco MDS 9700 Series Multilayer Directors.	8.1(1)	<a href="#">Cisco MDS 48-Port 32-Gbps Fiber Channel Switching Module, on page 43</a>
High-Voltage DC PSU	A 3500W High-Voltage DC (HVDC) Power Supply Unit (DS-CHV-3.5KW) is supported on Cisco MDS 9706 and Cisco MDS 9710 Directors.	6.2(19)	<a href="#">Power Supplies, on page 56</a>
Cisco MDS 24/10 port SAN Extension Module	The Cisco MDS 24/10 port SAN Extension Module is supported on Cisco MDS 9700 Series Multilayer Directors. With 24 line rate 2, 4, 8, 10, and 16-Gbps Fibre Channel ports and eight 1 and 10GE or two 40GE Fibre Channel over IP (FCIP) ports, this module enables large and scalable deployment of SAN extension solutions.	7.3(0)DY(1)	<a href="#">Cisco MDS 24/10 port SAN Extension Module, on page 46</a>
Cisco MDS 9718 Multilayer Director	The Cisco MDS 9718 chassis has 18 slots for one or two supervisor modules and up to 16 I/O modules. The chassis also holds up to six fabric modules, up to 16 AC or DC 3-kW power supplies, and three fan trays.	7.3(0)D1(1)	<a href="#">Cisco MDS 9718 Director, on page 5 and Technical Specifications, on page 187</a>
Cisco MDS-24 port 40-Gbps Fibre Channel over Ethernet Module	The Cisco MDS 9700 24-Port 40-Gbps Fibre Channel over Ethernet (FCoE) Module provides Cisco Unified fabric connectivity to the SAN core.	7.3(0)	<a href="#">Cisco MDS 24-Port 40-Gbps Fiber Channel over Ethernet Module, on page 49</a>
Cisco MDS 9706 Multilayer Director	Added the Cisco MDS 9706 Multilayer Director (DS-C9706). The chassis consists of 6 horizontal slots, where slots 1, 2, 5, and 6 are reserved for switching, services, and slots 3 and 4 for supervisor modules only.	6.2(9)	<a href="#">Cisco MDS 9706 Director, on page 9 and Technical Specifications, on page 187</a>
Cisco MDS 48-Port 10-Gigabit Fibre Channel over Ethernet Module	Added the Cisco MDS 48-Port 10-Gigabit Fibre Channel over Ethernet module (DS-X9848-480K9).	6.2(7)	<a href="#">Cisco MDS 48-Port 10-Gbps Fiber Channel over Ethernet Module, on page 50</a>
Supported SFP+ Transceiver	Added Supported 10-Gbps SFP+ Transceiver.	6.2(7)	<a href="#">Technical Specifications, on page 187</a>





## CHAPTER 2

# Product Overview

---

The Cisco MDS 9700 Series of Multilayer Directors elevate the standard for director-class switches. It allows a deployment of high-performance SANs with low cost of ownership, layering a rich set of intelligent features onto a high-performance, protocol-agnostic switch fabric.

The Cisco MDS 9700 Series of Multilayer Directors addresses the stringent requirements of large data center storage environments — Providing high availability, security, scalability, ease of management, and transparent integration of new technologies.

The Cisco MDS 9700 Series of Multilayer Directors include the following directors:

- Cisco MDS 9718 Director
- Cisco MDS 9710 Director
- Cisco MDS 9706 Director

This chapter has the following topics:

- [Cisco MDS 9718 Director, on page 5](#)
- [Cisco MDS 9710 Director, on page 7](#)
- [Cisco MDS 9706 Director, on page 9](#)
- [Chassis Description , on page 10](#)
- [System LEDs , on page 21](#)
- [Supervisor Modules, on page 21](#)
- [Crossbar Fabric Switching Modules, on page 32](#)
- [Fiber Channel Switching Modules, on page 40](#)
- [SAN Extension Modules, on page 46](#)
- [Fiber Channel over Ethernet Switching Modules, on page 48](#)
- [Fan Modules or Trays , on page 52](#)
- [Power Supplies, on page 56](#)
- [Supported Transceivers, on page 59](#)

## Cisco MDS 9718 Director

The Cisco MDS 9718 Director is a high-port density switch that is designed to meet the requirements of a large-scale enterprise data center storage environment. It provides superior performance, scalability, redundancy,

multiprotocol convergence, and enterprise-grade availability in a data center network. The Cisco MDS 9718 Director includes the following components:

- An 18-slot chassis (DS-C9718)
- 1-2 supervisor modules. The supervisor modules include the following types:
  - Cisco MDS 9700 Supervisor-4 Module (DS-X97-SF4-K9)
  - Cisco MDS 9700 Supervisor-1E Module (DS-X97-SF1E-K9)
- 1-6 crossbar switching fabric modules. The crossbar switching fabric modules include the following types:
  - Cisco MDS 9718 Crossbar Fabric-3 Switching Module (DS-X9718-FAB3)
  - Cisco MDS 9718 Crossbar Fabric-1 Switching Module (DS-X9718-FAB1)
- 1-16 I/O modules. The I/O modules include the following types:
  - A 48-Port 64-Gbps Fiber Channel Switching Module (DS-X9748-3072K9)
  - A 48-Port 32-Gbps Fiber Channel Switching Module (DS-X9648-1536K9)
  - A 48-Port 16-Gbps Fiber Channel Switching Module (DS-X9448-768K9)
  - A 48-Port 10-Gbps Fiber Channel over Ethernet Module (DS-X9848-480K9)
  - A 24-Port 40-Gbps Fiber Channel over Ethernet (FCoE) Module (DS-X9824-960K9)
  - A 24/10-port SAN Extension Module (DS-X9334-K9)
- Three fan modules or trays
  - Cisco MDS 9718 Fan Module (DS-C9718-FAN)
- 1-16 power supply units. The power supply units include the following types:
  - Cisco MDS 9700 3000W AC power supply (DS-CAC97-3KW)
  - Cisco MDS 9700 3000W DC power supply (DS-CDC97-3KW)
  - Cisco MDS 9700 3500W High-Voltage power supply (DS-CHV-3.5KW)
- Cisco MDS 9718 Accessory Kit for Cisco (DS-9718-KIT-CCO)

The Cisco MDS 9718 Director supports up to 768 ports in an 18-slot modular chassis, with up to 1152 ports in a single rack. The 768 ports can be configured as 2/4/8/10/16/32/64-Gbps Fiber Channel ports, or 1/10-Gbps Fiber Channel over Ethernet (FCoE) ports, or 384 40-Gbps FCoE ports, or a mix of both Fiber Channel and FCoE ports. In addition to the FC and FCoE ports the Cisco MDS 9718 Director supports up to 128 1/10-Gbps IPStorage ports or 32 25-Gbps IPStorage ports or 32 40-Gbps IPStorage ports. These IPStorage ports are used for establishing FCIP ISLs.

## Cisco MDS 9718 Director Features

The Cisco MDS 9718 Director supports the following features:

- Up to 6(DS-X9718-FAB3) x 512 x 16 slots = 49.152-Tbps per chassis Fiber Channel switching, full duplex-bandwidth
- Up to 6(DS-X9718-FAB1) x 256 x 16 slots = 24.576-Tbps per chassis Fiber Channel switching, full duplex-bandwidth
- Up to 6(DS-X9718-FAB3) x 440 x 16 slots = 42.240-Tbps per chassis FCoE switching bandwidth
- Up to 6(DS-X9718-FAB1) x 220 x 16 slots = 21.120-Tbps per chassis FCoE switching bandwidth
- Comprehensive security features
- Intelligent network services, including VSAN technology, IVR, and smart zoning
- SAN management tools including Cisco Nexus Dashboard Fabric Controller (Formerly Cisco Data Center Network Manager (DCNM)) and the command-line interface (CLI)
- Online diagnostics (GOLD, Call Home, and so on)
- Multiprotocol architecture, including Fiber Channel, Fiber Channel over Ethernet (FCoE), Fiber Channel over IP (FCIP), and NVMe over fabrics
- High availability with full redundant components, including fabric cards, supervisors, and power supplies
- Industry-leading scalability

## Cisco MDS 9710 Director

The Cisco MDS 9710 Director is a high-performance SAN switch that is designed to meet the requirements of an enterprise data center storage environment. The Cisco MDS 9710 Director includes the following components that are designed specifically for a deployment in the Cisco MDS 9700 series:

- A 10-slot chassis (DS-C9710)
- 1-2 supervisor modules. The supervisor modules include the following types:
  - Cisco MDS 9700 Supervisor-4 Module (DS-X97-SF4-K9)
  - Cisco MDS 9700 Supervisor-1 Module (DS-X97-SF1-K9)
- 1-6 crossbar switching fabric modules. The crossbar switching fabric modules include the following types:
  - Cisco MDS 9710 Crossbar Fabric-3 Switching Module (DS-X9710-FAB3)
  - Cisco MDS 9710 Crossbar Fabric-1 Switching Module (DS-X9710-FAB1)
- 1-8 I/O modules. These I/O modules include the following types:
  - A 48-Port 64-Gbps Fiber Channel Switching Module (DS-X9748-3072K9)
  - A 48-Port 32-Gbps Fiber Channel Switching Module (DS-X9648-1536K9)
  - A 48-Port 16-Gbps Fiber Channel Switching Module (DS-X9448-768K9)
  - A 48-Port 10-Gbps Fiber Channel over Ethernet Module (DS-X9848-480K9)

- A 24-Port 40-Gbps Fiber Channel over Ethernet (FCoE) Module (DS-X9824-960K9)
- A 24/10-port SAN Extension Module (DS-X9334-K9)
- Three fan modules or trays
  - Cisco MDS 9710 Fan Module (DS-C9710-FAN)
- 1-8 power supply units. The power supply units include the following types:
  - Cisco MDS 9700 3000W AC power supply (DS-CAC97-3KW)
  - Cisco MDS 9700 3000W DC power supply (DS-CDC97-3KW)
  - Cisco MDS 9700 3500W High-Voltage power supply (DS-CHV-3.5KW)
- Cisco MDS 9710 Accessory Kit for Cisco (DS-9710-KIT-CCO)

The Cisco MDS 9710 Director supports up to 384 ports in a 10-slot modular chassis, with up to 1152 ports in a single rack. The 384 ports can be configured as 2/4/8/10/16/32/64-Gbps Fiber Channel ports, or 1/10-Gbps Fiber Channel over Ethernet (FCoE) ports, or 192 40-Gbps FCoE ports, or a mix of both Fiber Channel and FCoE ports. In addition to the FC and FCoE ports the Cisco MDS 9710 Director supports up to 64 1/10-Gbps IPStorage ports or 16 25-Gbps IPStorage ports or 16 40-Gbps IPStorage ports. These IPStorage ports are used for establishing FCIP ISLs.

## Cisco MDS 9710 Director Features

The Cisco MDS 9710 Director supports the following features:

- Up to 6(DS-X9710-FAB3) x 512 x 8 slots = 24.576-Tbps per chassis Fiber Channel switching, full-duplex bandwidth
- Up to 6(DS-X9710-FAB1) x 256 x 8 slots = 12.288-Tbps per chassis Fiber Channel switching, half-duplex bandwidth
- Up to 6(DS-X9710-FAB3) x 440 x 8 slots = 21.120-Tbps per chassis FCoE switching bandwidth
- Up to 6(DS-X9710-FAB1) x 220 x 8 slots = 10.560-Tbps per chassis FCoE switching bandwidth
- Comprehensive security features
- Intelligent network services, including VSAN technology, IVR, and smart zoning
- SAN management tools including Cisco Nexus Dashboard Fabric Controller (NDFC) and the command-line interface (CLI)
- Online diagnostics (GOLD, Call Home, and so on)
- Multiprotocol architecture, including Fiber Channel, Fiber Channel over Ethernet (FCoE), Fiber Channel over IP (FCIP), and NVMe over fabrics
- High availability with full redundant components, including fabric cards, supervisors, and power supplies
- Industry-leading scalability

# Cisco MDS 9706 Director

The Cisco MDS 9706 Director is designed for a deployment in small-to medium-sized storage networks that can support enterprise clouds and business transformation.

The Cisco MDS 9706 Director includes the following components:

- A 6-slot chassis (DS-C9706)
- 1-2 supervisor modules. The supervisor modules include the following types:
  - Cisco MDS 9700 Supervisor-4 Module (DS-X97-SF4-K9)
  - Cisco MDS 9700 Supervisor-1 Module (DS-X97-SF1-K9)
- 1-6 crossbar switching fabric modules. The crossbar switching fabric modules include the following types:
  - Cisco MDS 9706 Crossbar Fabric-3 Switching Module (DS-X9706-FAB3)
  - Cisco MDS 9706 Crossbar Fabric-1 Switching Module (DS-X9706-FAB1)
- 1-4 I/O modules. These I/O modules include the following types:
  - A 48-Port 64-Gbps Fiber Channel Switching Module (DS-X9748-3072K9)
  - A 48-Port 32-Gbps Fiber Channel Switching Module (DS-X9648-1536K9)
  - A 48-Port 16-Gbps Fiber Channel Switching Module (DS-X9448-768K9)
  - A 48-Port 10-Gbps Fiber Channel over Ethernet Module (DS-X9848-480K9)
  - A 24-Port 40-Gbps Fiber Channel over Ethernet (FCoE) Module (DS-X9824-960K9)
  - A 24/10-port SAN Extension Module (DS-X9334-K9)
- Three fan modules or trays
  - Cisco MDS 9706 Fan Module (DS-C9706-FAN)
- 1-4 power supply units. The power supply units include the following types:
  - Cisco MDS 9700 3000W AC power supply (DS-CAC97-3KW)
  - Cisco MDS 9700 3000W DC power supply (DS-CDC97-3KW)
  - Cisco MDS 9700 3500W High-Voltage power supply (DS-CHV-3.5KW)
- Cisco MDS 9706 Accessory Kit for Cisco (DS-9706-KIT-CCO)

The Cisco MDS 9706 supports up to 192 ports in a 6-slot modular chassis, with up to 768 ports in a single rack. The 192 ports can be configured as 2/4/8/10/16/32/64-Gbps Fiber Channel ports, or 1/10-Gbps Fiber Channel over Ethernet (FCoE) ports, or 96 40-Gbps FCoE ports, or a mix of both Fiber Channel and FCoE ports. In addition to the FC and FCoE ports the Cisco MDS 9706 Director supports up to 32 1/10-Gbps IPStorage ports or 8 25-Gbps IPStorage ports or 8 40-Gbps IPStorage ports. These IPStorage ports are used for establishing FCIP ISLs.

## Cisco MDS 9706 Director Features

The Cisco MDS 9706 Director supports the following features:

- Up to 6(DS-X9706-FAB3) x 512 x 4 slots = 12.288-Tbps per chassis Fiber Channel switching, full-duplex bandwidth
- Up to 6(DS-X9706-FAB1) x 256 x 4 slots = 6.144-Tbps per chassis Fiber Channel switching, full-duplex bandwidth
- Up to 6(DS-X9706-FAB3) x 440 x 4 slots = 10.560-Tbps per chassis FCoE switching bandwidth
- Up to 6(DS-X9706-FAB1) x 220 x 4 slots = 5.280-Tbps per chassis FCoE switching bandwidth
- Comprehensive security features
- Intelligent network services, including VSAN technology, IVR, and smart zoning
- SAN management tools including Cisco Nexus Dashboard Fabric Controller (Formerly Cisco Data Center Network Manager (DCNM)) and the command-line interface (CLI)
- Online diagnostics (GOLD, Call Home, and so on)
- Multiprotocol architecture, including Fiber Channel, Fiber Channel over Ethernet (FCoE), Fiber Channel over IP (FCIP), and NVMe over fabrics
- High availability with full redundant components, including fabric cards, supervisors, and power supplies
- Industry-leading scalability

## Chassis Description

This section describes the chassis in the Cisco MDS 9700 Multilayer Director Series. The chassis are:

### Cisco MDS 9718 Director Chassis

The Cisco MDS 9718 Director (DS-C9718) is an 18-slot chassis with up to two supervisor modules and up to 16 I/O modules. The chassis holds up to six crossbar fabric switching modules, up to 16 AC or DC 3-kW power supplies, and three fan modules. Airflow is front-to-back (port-side intake) in the Cisco MDS 9718 chassis.



---

**Note** The base configuration of the Cisco MDS 9718 (DS-C9718) Director ships with two supervisor modules (DS-X97-SF4-K9), six crossbar fabric switching modules (DS-X9718-FAB3), and 12 power supplies.

---

To group the networking cables for each I/O module on this chassis, you can install cable management frames on the chassis. You can also install an optional locking front door, an optional set of air filters on the front door, and cable management frames.

The following figure shows the standard hardware features seen from the front of the chassis.



Figure 1: Cisco MDS 9718 Chassis Front View

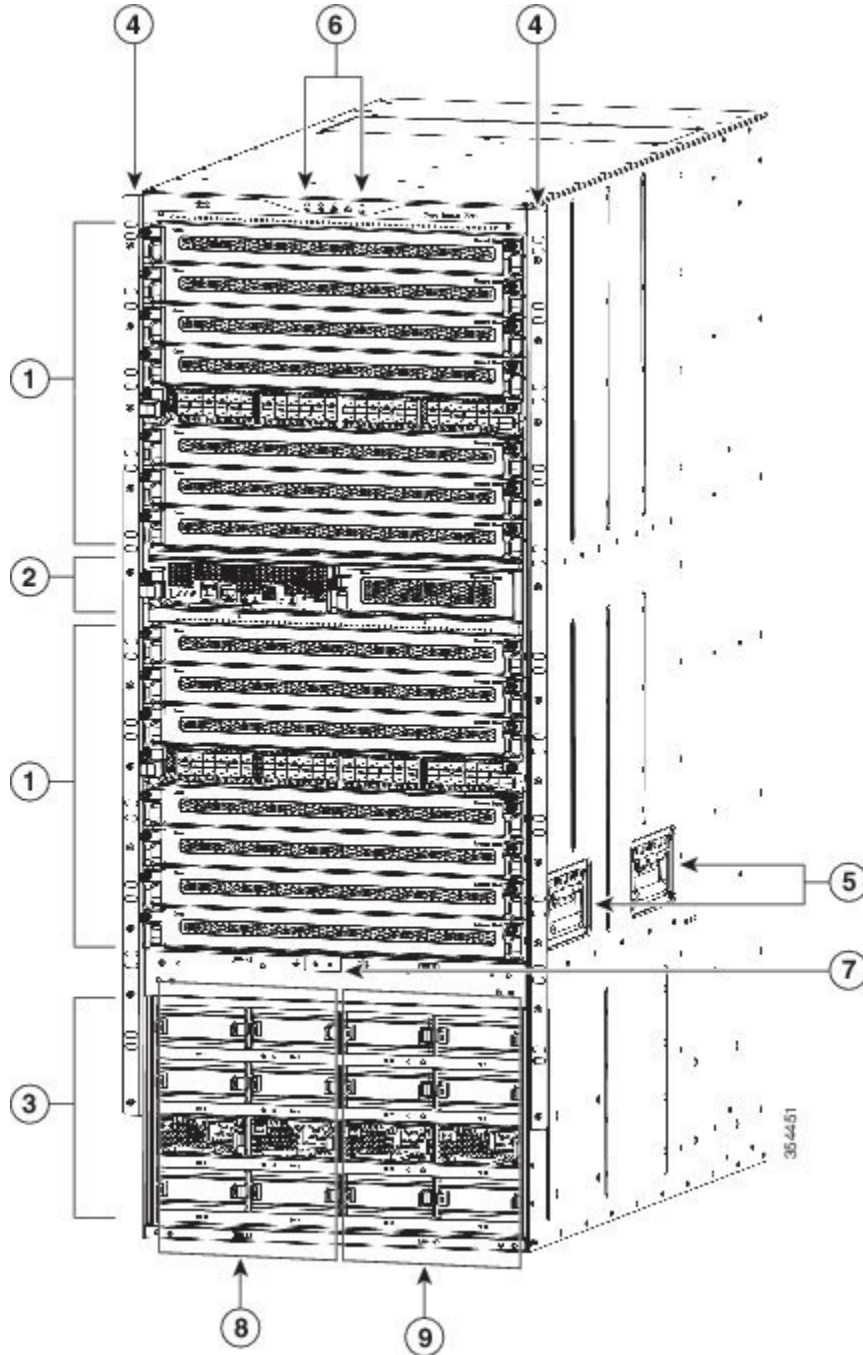

1	I/O modules slots numbered 1-8 and 11-18 from top to bottom.	6	Chassis LEDs
---	--	---	--------------

2	<p>Supervisor modules (one or two) in slots numbered 9 and 10 from left to right.</p> <p>Each slot is half the width of the chassis and each slot can hold one supervisor module.</p>	7	Ground point
3	<p>Power supply unit bays numbered 1-16, starting from the top left and increasing left to right and top to bottom.</p> <ul style="list-style-type: none"> <li>• There are four rows of power supply bays at the bottom of the chassis. Each bay can hold one power supply.</li> <li>• The top row has bays 1-4, numbered left to right.</li> <li>• The second row has bays 5-8, numbered left to the right.</li> <li>• The third row has bays 9-12, numbered left to the right.</li> <li>• The fourth row has bays 13-16, numbered left to the right.</li> </ul>	8	Grid A PSU bays (1, 2, 5, 6, 9, 10, 13, 14)
4	Chassis mounting brackets	9	Grid B PSU bays (3, 4, 7, 8, 11, 12, 15, 16)
5	<p>Chassis handles</p> <p><b>Note</b> Handles are to be used only for positioning an empty chassis.</p>		

The following figure shows the standard hardware features seen from the rear of the chassis.

*Figure 2: Cisco MDS 9718 Chassis Rear View*

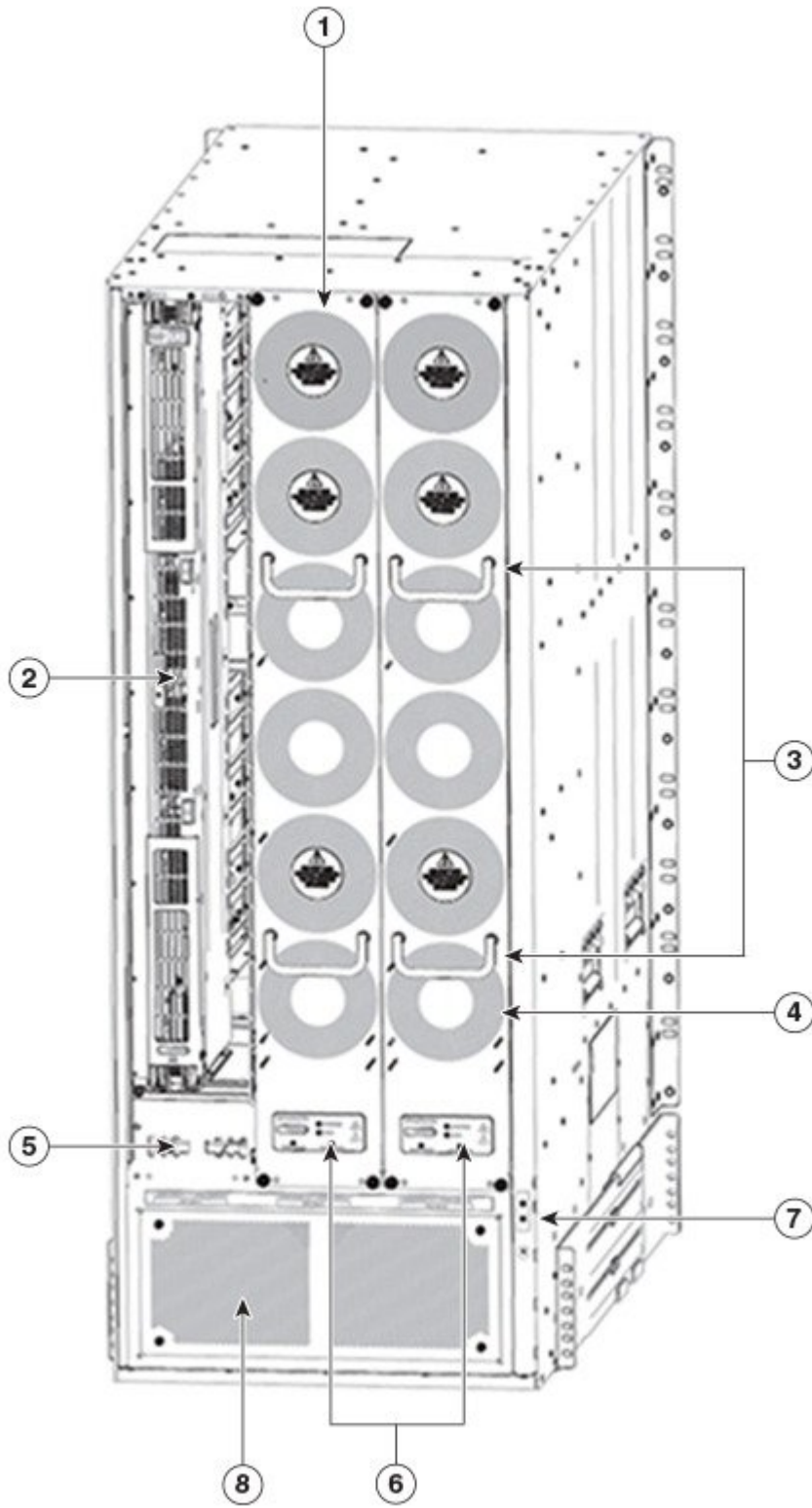

354820

1	Fan modules or trays - (Three fan modules or trays) 1-3 are numbered left to the right. When the fan modules are installed, they cover the crossbar fabric switching modules.  Only two fan modules or trays are shown in the figure. One fan module or tray is removed to show the crossbar fabric switching module in the back.	5	Fan power connector
2	Crossbar fabric switching modules - (up to six crossbar fabric switching modules with two modules behind each fan module or tray). The crossbar fabric switching modules 1 and 2 are behind the fan module 1, fabric modules 3 and 4 are behind the fan module 2, and fabric modules 5 and 6 are behind the fan module 3.	6	Fan and crossbar fabric switching modules LEDs
3	Fan module or tray handle	7	Ground point
4	Fan module or tray exhaust	8	PSU exhaust

## Cisco MDS 9710 Director Chassis

The Cisco MDS 9710 Director (DS-C9710) is a 10-slot chassis with up to two supervisor modules and up to 8 I/O modules. The chassis holds up to six crossbar fabric switching modules, up to 8 AC or DC 3-kW power supplies, and three fan modules. Airflow is front-to-back (port-side intake) in the Cisco MDS 9710 chassis.



**Note** The base configuration of the Cisco MDS 9710 (DS-C9710) Director ships with two supervisor modules (DS-X97-SF4-K9), three crossbar fabric switching modules (DS-X9718-FAB3), and six power supplies.

The following figure shows the front view of the Cisco MDS 9710 chassis.

Figure 3: Cisco MDS 9710 Chassis Front View

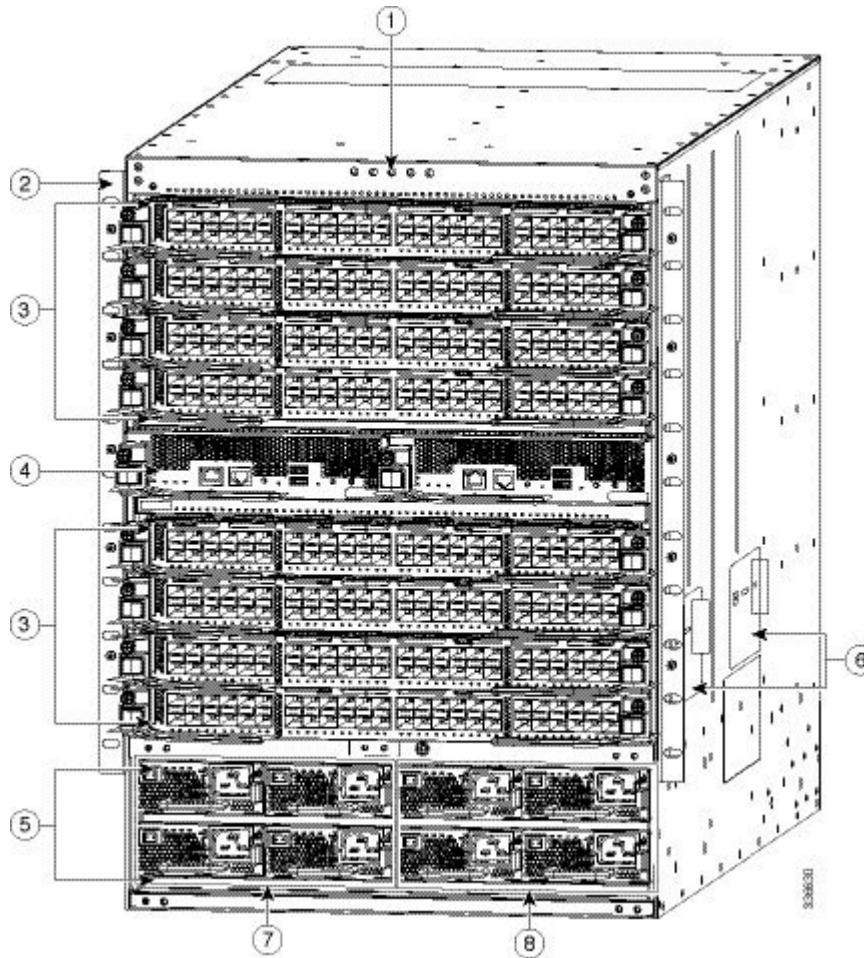

1	Chassis LEDs
2	Chassis mounting brackets
3	I/O modules slots numbered 1-4 and 7-10 from top to bottom
4	Supervisor modules (one or two) in slots numbered 5 and 6 from left to right. Each slot is half the width of the chassis and each slot can hold one supervisor module
5	Power supplies (up to 8 bays). <ul style="list-style-type: none"> <li>• There are two rows of power supply bays at the bottom of the chassis. Each bay can hold one power supply.</li> <li>• The top row has bays 1-4, numbered left to right.</li> <li>• The second row has bays 5-8, numbered left to the right.</li> </ul>

6	Chassis handles <b>Note</b> Handles are to be used only for positioning an empty chassis.
7	Grid A PSU bays (1, 2, 5, 6)
8	Grid B PSU bays (3, 4, 7, 8)

The following figure shows the rear view of the Cisco MDS 9710 chassis.

**Figure 4: Cisco MDS 9710 Chassis Rear View**

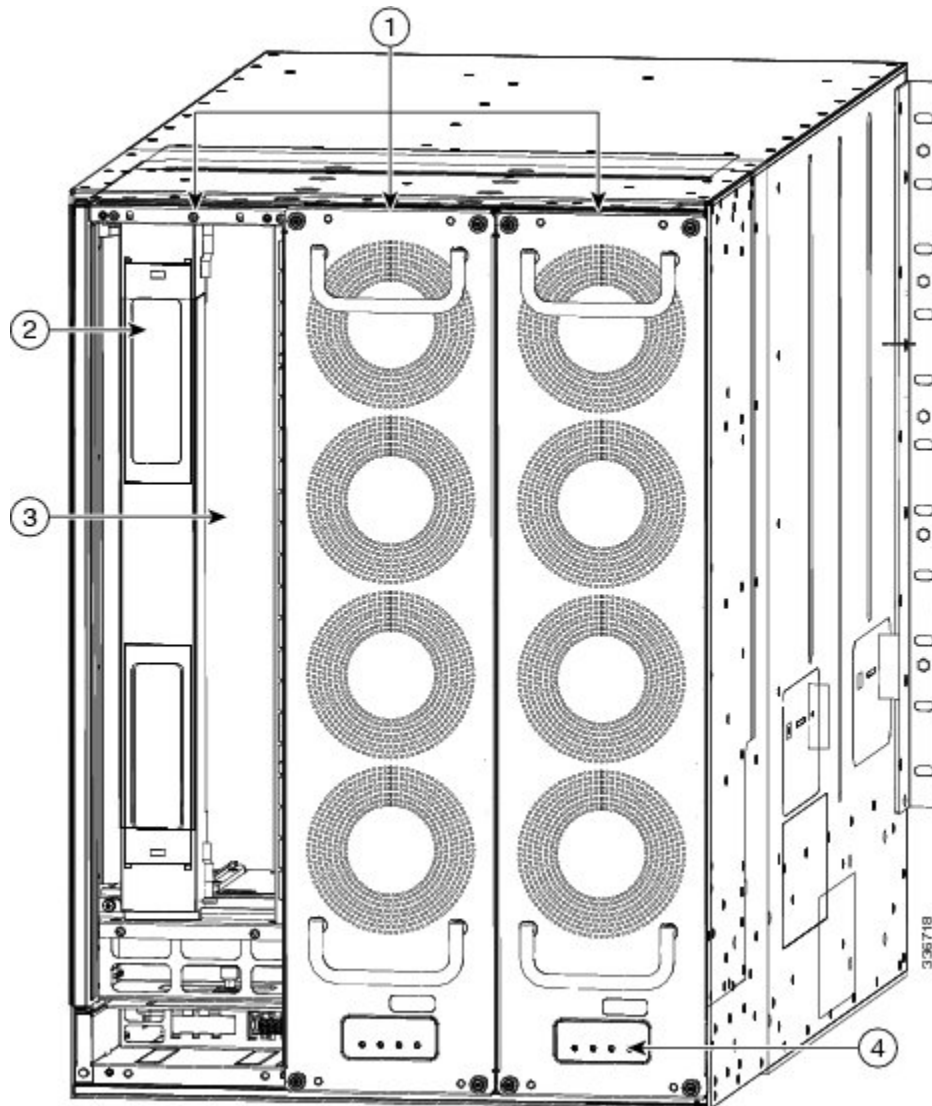

1	Fan modules or trays - (Three fan modules or trays) 1-3 are numbered left to the right. When the fan modules or trays are installed, they cover the crossbar fabric switching modules.  Only two fan modules or trays are shown in the figure. One fan module or tray is removed to show the crossbar fabric switching module in back.
2	Crossbar fabric switching modules - (up to six crossbar fabric switching modules with two modules behind each fan module). The crossbar fabric switching modules 1 and 2 are behind the fan module or tray 1, fabric modules or trays 3 and 4 are behind the fan module or tray 2, and fabric modules or trays 5 and 6 are behind the fan module or tray 3.
3	Midplane
4	Crossbar fabric switching modules and fan LEDs

The Cisco MDS 9710 chassis can be mounted on a standard 19-inch EIA equipment rack by using the standard rack-mount hardware, or mounted on a standard two-post Telco rack, with mounting rails.

## Cisco MDS 9706 Director Chassis

The Cisco MDS 9706 Director (DS-C9706) is a six-slot chassis with one or two supervisor modules, and up to four I/O modules. The chassis holds up to six crossbar fabric switching modules, up to four AC or DC 3-kW power supplies and three fan modules. Airflow is front-to-back (port-side intake) in the Cisco MDS 9706 chassis.



---

**Note** The base configuration of MDS 9706 (DS-C9706) ships with two supervisor modules (DS-X97-SF4-K9), three crossbar fabric switching modules (DS-X9718-FAB3), and four power supplies.

---

The following figure shows the front view of the Cisco MDS 9706 chassis.



Figure 5: Cisco MDS 9706 Chassis Front View

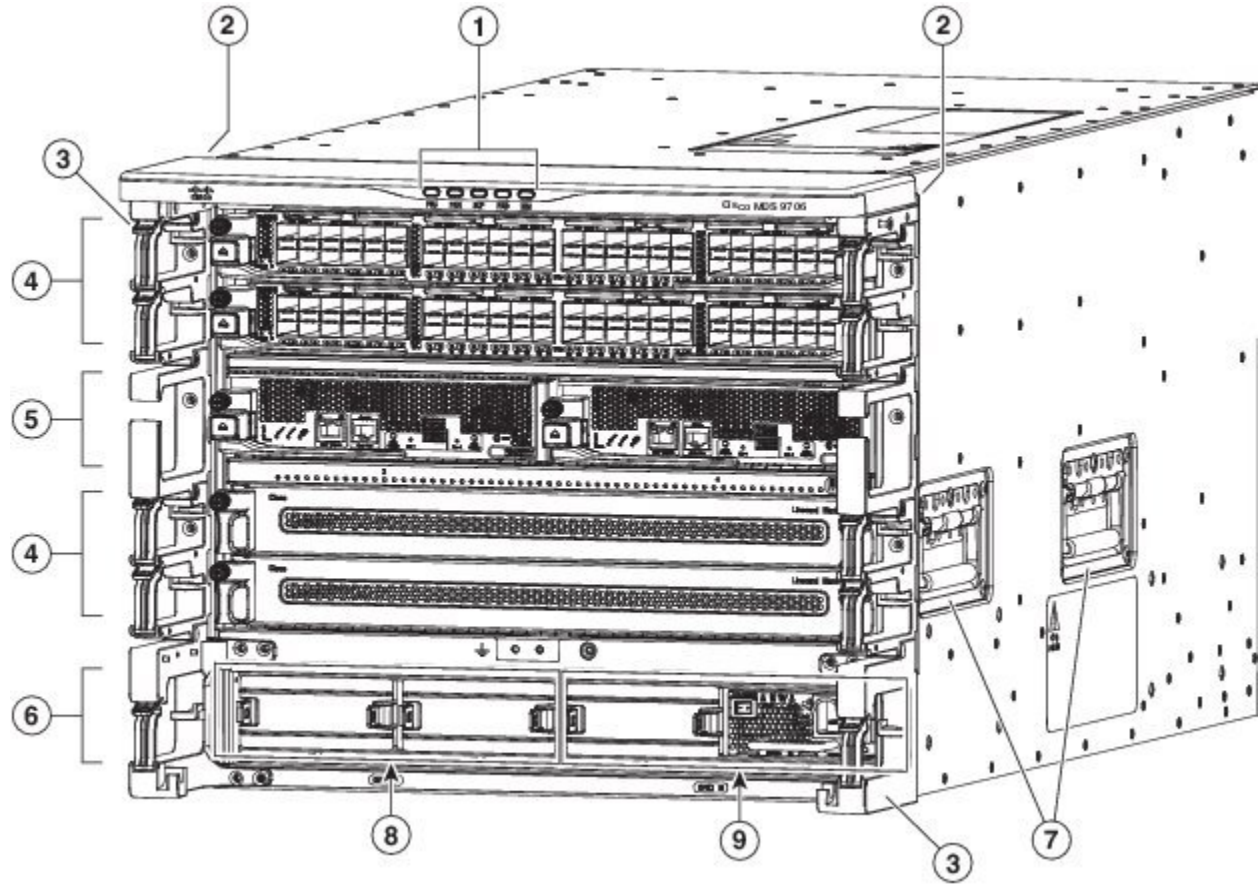

1	Chassis LEDs
2	Chassis mounting brackets
3	Cable management frame
4	I/O modules slots numbered 1-2 and 5-6 from top to bottom
5	Supervisor modules (one or two) in slots numbered 3 and 4 from left to right. Each slot is half the width of the chassis and each slot can hold one supervisor module
6	Power supplies (up to 4 bays). The last row has 4 bays of power supply at the bottom of the chassis. Each bay can hold one power supply.
7	Chassis handles <b>Note</b> Handles are to be used only for positioning an empty chassis

8	Grid A PSU bays (1, 2 slots)
9	Grid B PSU bays (3, 4 slots)

The following figure shows the rear view of the Cisco MDS 9706 chassis.

Figure 6: Cisco MDS 9706 Chassis Rear View

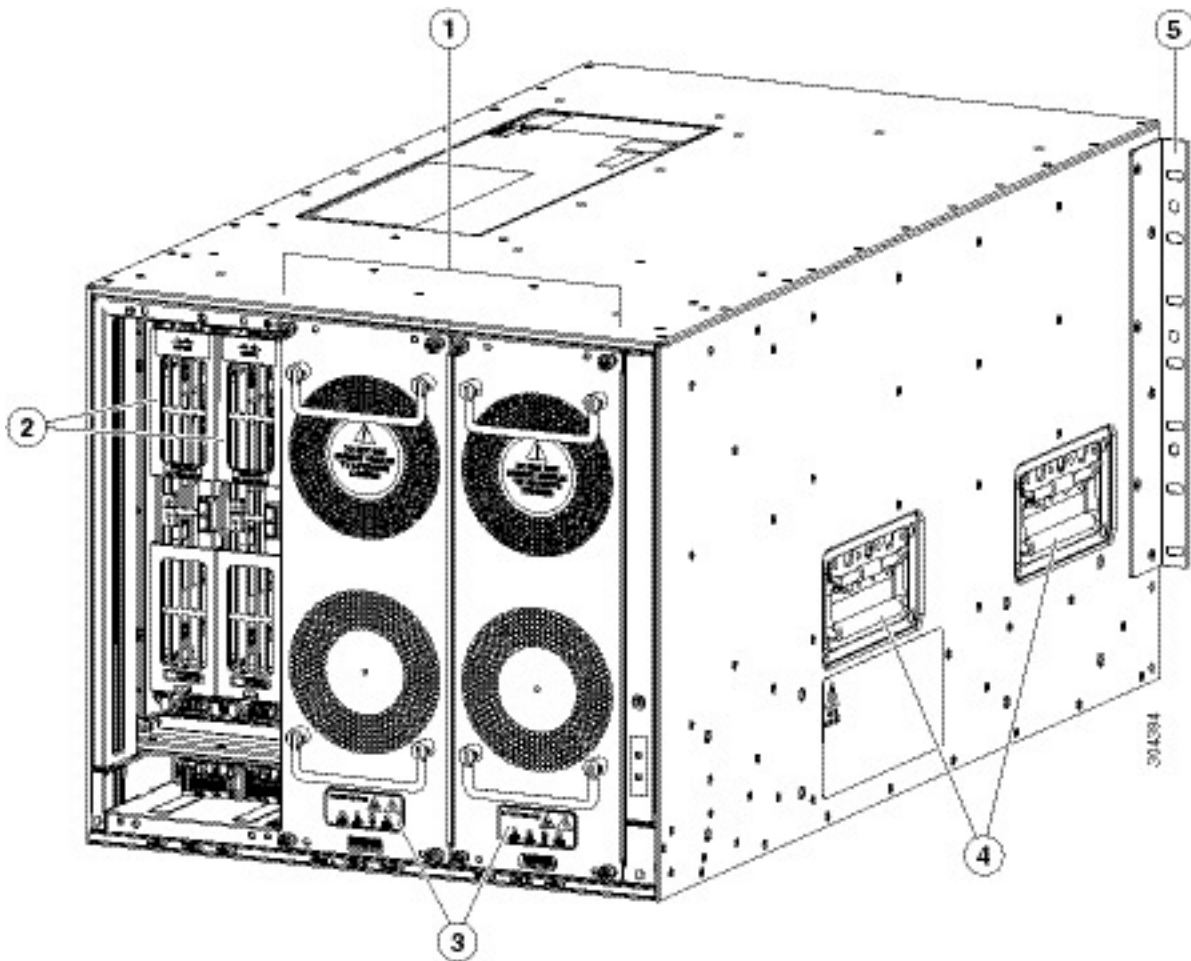

1	<p>Fan modules or trays - (Three fan modules or trays) 1-3 are numbered left to the right. When the fan modules or trays are installed, they cover the crossbar fabric switching modules.</p> <p>Only two fan modules or trays are shown in the figure. One fan module or tray is removed to show the crossbar fabric switching module in back.</p>
2	<p>Crossbar fabric switching modules - (up to six crossbar fabric switching modules with two modules behind each fan module).</p> <p>The crossbar fabric switching modules 1 and 2 are behind the fan module or tray 1, fabric modules 3 and 4 are behind the fan module or tray 2, and fabric modules 5 and 6 are behind the fan module or tray 3.</p>

3	Crossbar fabric switching modules and fan LEDs
4	Handles used for adjusting the chassis placement
5	Vertical mounting brackets

## System LEDs

The following table describes the system LEDs for the Cisco MDS 9700 Series.

**Table 2: Cisco MDS 9700 Series System LEDs**

LED	Status	Description
Power supply unit	Green	Power supply units are operational.
	Amber	One of the following problems has occurred: <ul style="list-style-type: none"> <li>• Any power supply unit LED is red.</li> <li>• Any power supply unit is down.</li> </ul>
Fan module	Green	Fan modules are operational.
	Amber	At least one I/O module has the red STATUS LED.
Supervisor modules	Green	Supervisor modules are operational.
	Amber	At least one I/O module has the red STATUS LED.
Crossbar fabric switching modules	Green	Crossbar fabric switching modules are operational.
	Amber	At least one I/O module has the red STATUS LED.
I/O modules	Green	Switching modules are operational.
	Amber	At least one I/O module has the red STATUS LED.

## Supervisor Modules

This section describes supervisor modules that are supported by different Cisco MDS 9700 Series switches. The supervisor modules are:

### Cisco MDS 9700 Series Supervisor-4 Module

The Cisco MDS 9700 Series Supervisor-4 Module (DS-X97-SF4-K9) provides control and management functions for the Cisco MDS Director switches and enables intelligent, resilient, scalable, and high-performance multilayer SAN switching.

The Cisco MDS 9700 Series Supervisor-4 Module (DS-X97-SF4-K9) is supported on the Cisco MDS 9706 and 9710 Multilayer Directors from Cisco MDS NX-OS Release 8.4(1) or later. It is supported on the Cisco MDS 9718 Multilayer Director from Cisco MDS NX-OS Release 8.4(2a) or later.

The Cisco MDS 9700 Series Supervisor-4 Module supports the following features:

- Supports up to 768 2/4/8/10/16/32/64-Gbps Fiber Channel ports, or 1/10-Gbps FCoE ports in a single Cisco MDS 9718 Multilayer Director chassis
- Supports up to 384 2/4/8/10/16/32/64-Gbps Fiber Channel ports, or 1/10-Gbps FCoE ports in a single Cisco MDS 9710 Multilayer Director chassis
- Supports up to 192 2/4/8/10/16/32/64-Gbps Fiber Channel ports, or 1/10-Gbps FCoE ports in a single Cisco MDS 9706 Multilayer Director chassis
- Supports up to 384 40-Gbps FCoE ports in a single Cisco MDS 9718 Multilayer Director chassis
- Supports up to 192 40-Gbps FCoE ports in a single Cisco MDS 9710 Multilayer Director chassis
- Supports up to 96 40-Gbps FCoE ports in a single Cisco MDS 9706 Multilayer Director chassis
- Supports up to 48-Tbps in a single Cisco MDS 9718 Multilayer Director chassis
- Supports up to 24-Tbps in a single Cisco MDS 9710 Multilayer Director chassis
- Supports up to 12-Tbps in a single Cisco MDS 9706 Multilayer Director chassis
- Supports DS-X9718-FAB3, DS-X9710-FAB3 and DS-X9706-FAB3 crossbar fabric switching modules on the Cisco MDS 9718, Cisco MDS 9710 and Cisco MDS 9706 Multilayer Directors respectively
- Multipathing based on Fabric Shortest Path First (FSPF)
- Nondisruptive software upgrades
- Provides high availability. The Cisco MDS 9700 Series Supervisor-4 Module can automatically restart failed processes, making it exceptionally robust. In the rare event that a supervisor module is reset, complete synchronization between the Active and Standby supervisor modules helps ensure a Stateful Failover with no disruption of traffic.
- Supports Secure Boot capabilities
- Supports two USB 3.0 ports
- Network management through the command-line interface (CLI) and through Cisco Data Center Network Manager (DCNM)
- Extensive security features including RADIUS and TACACS+, Fiber Channel Security Protocol (FC-SP), Secure File Transfer Protocol (SFTP), Secure Shell (SSH) Protocol, and Simple Network Management Protocol Version 3 (SNMPv3) implementing Advanced Encryption Standard (AES), VSANs, hardware-enforced zoning, ACLs, and per-VSAN role-based access control
- Integrated hardware-based virtual SAN (VSAN) technology and inter-VSAN routing (IVR)
- Network services such as access control lists (ACLs) and quality of service (QoS)
- Smart zoning
- Power-on self-test (POST) and diagnostics
- Switched Port Analyzer (SPAN) and Remote Switched Port Analyzer (RSPAN)

The following figure shows the Cisco MDS 9700 Series Supervisor-4 Module.

Figure 7: Cisco MDS 9700 Series Supervisor-4 Module Front View

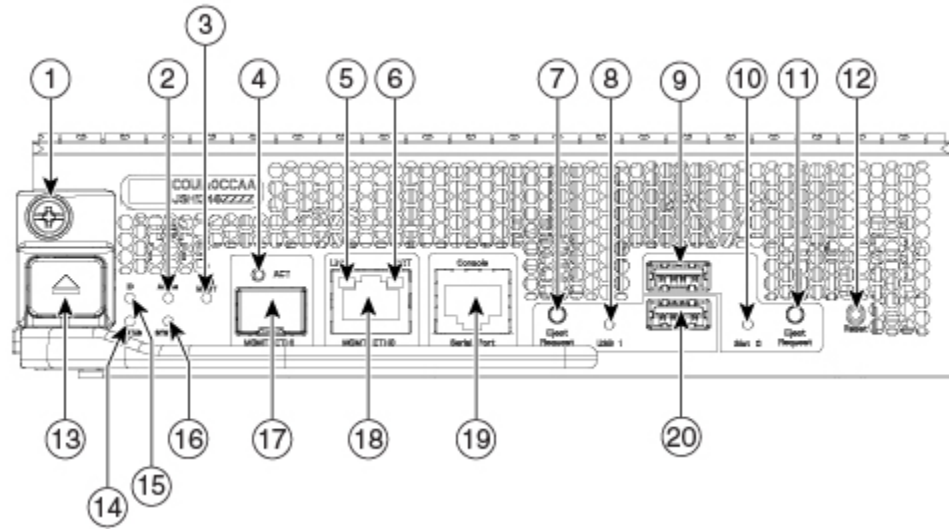

956/097

1	Module retaining screw
2	Active: supervisor redundancy status LED
3	PWR MGMT: system power status LED
4	ACT: management port packet activity LED
5	Link: management port link status LED
6	ACT: management port packet activity LED
7	Eject Request: eject request button for USB3 device
8	USB3: usb3 status LED
9	USB Slot 0: USB ports
10	Slot0: slot0 status LED
11	Eject Request: eject request button for a slot0 device
12	Reset: module reset button
13	Module lock release button
14	Status: system diagnostic test status LED
15	ID: locator LED
16	System: system environment status LED
17	MGMT Ethernet1: MGMT1 Ethernet out of band management port
	Note: The MGMT1 Ethernet port is not yet supported.
18	MGMT Ethernet0: MGMT0 Ethernet out of band management port.
19	Console Serial Port: module RS232 serial console port
20	USB Slot 1: USB port

The following table describes the LEDs on the Cisco MDS 9700 Series Supervisor-4 Module.

**Table 3: Cisco MDS 9700 Series Supervisor-4 Module LEDs**

LED	Status	Description
ID	Blinking blue	A user has activated this LED to allow a person to find the module.
	Off	Location identification is deactivated for this module.
Status	Green	All module diagnostics passed. The module is operational.
	Red	Indicates one of the following conditions: <ul style="list-style-type: none"> <li>The module has detected an error and cannot power up.</li> <li>The module is not properly inserted.</li> <li>A bootup or runtime diagnostic test has failed.</li> </ul>
	Blinking Red	Indicates one of the following conditions: <ul style="list-style-type: none"> <li>An over temperature condition has occurred. (A temperature threshold has been exceeded during an environmental monitoring.)</li> <li>The module is resetting.</li> <li>The ejector lever is open.</li> </ul>
	Off	The module is not receiving power.
System	Green	All environmental sensors in the system are within operating range.
	Amber	At least one power supply has failed or the power supply is low.
	Red	The temperature of the supervisor module exceeded the maximum allowed.
Active	Green	The supervisor is operational and in the HA-active state.
	Amber	The supervisor module is in the HA-standby state.
Power Management	Green	There is sufficient power available for all installed modules.
	Amber	There is insufficient power for all installed modules.
MGMT0 Ethernet	Green	The mgmt0 interface is administratively active when the module is in the HA-active state. From Cisco MDS NX-OS Release 8.4(2), when the module is in the HA-standby state, the mgmt0 interface is not administratively active.
	Amber	On Cisco MDS NX-OS Release 8.4(1a) or earlier, when the module is in the HA-standby state, the mgmt0 interface is not administratively active.
	Off	The mgmt0 interface is uninitialized. No signal is detected.
ACT	Green	Frames are being transmitted or received by the interface.
	Off	There is no activity on the interface.

LED	Status	Description
Link	Green	The management port link is operational.
	Amber	The management port link has been disabled by s
	Blinking amber	The management port has been disabled by a har
	Off	No link signal received.
USB3	Green	The flash device is mounted.
	Red	The device is a valid device type, but failed to be file system format.
	Off	The flash device is not mounted and can be safely
Slot0	Green	The flash device is mounted.
	Red	The device is a valid device type, but failed to be file system format.
	Off	The flash device is not mounted and can be safely

## Cisco MDS 9700 Series Supervisor-1E Module

The Cisco MDS 9700 Series Supervisor-1E Module (DS-X97-SF1E-K9) delivers advanced switching technology and resources to support the 18 slot chassis (DS-C9718).

The DS-X97-SF1E-K9 module is designed for the Cisco MDS 9718 Director.

The Cisco MDS 9700 Series Supervisor-1E Module supports the following features:

- Supports up to 768 2/4/8/10/16/32-Gbps Fiber Channel ports, or 1/10-Gbps FCoE ports in a single Cisco MDS 9718 Multilayer Director chassis
- Supports up to 384 40-Gbps FCoE ports in a single Cisco MDS 9718 Multilayer Director chassis
- Supports up to 48-Tbps of Fiber Channel system bandwidth
- Supports DS-X9718-FAB1 crossbar fabric switching module on the Cisco MDS 9718 Multilayer Director
- Multipathing based on Fabric Shortest Path First (FSPF)
- Nondisruptive software upgrades
- Provides high availability. The Cisco MDS 9700 Series Supervisor-1E Module can automatically restart failed processes, making it exceptionally robust. In the rare event that a supervisor module is reset, complete synchronization between the Active and Standby supervisor modules helps ensure a Stateful Failover with no disruption of traffic.
- Network management through the command-line interface (CLI) and through Cisco Data Center Network Manager (DCNM)
- Extensive security features including RADIUS and TACACS+, Fiber Channel Security Protocol (FC-SP), Secure File Transfer Protocol (SFTP), Secure Shell (SSH) Protocol, and Simple Network Management Protocol Version 3 (SNMPv3) implementing Advanced Encryption Standard (AES), VSANs, hardware-enforced zoning, ACLs, and per-VSAN role-based access control (RBAC)
- Support for virtual SAN (VSAN) technology and inter-VSAN routing (IVR)

- Network services such as access control lists (ACLs) and quality of service (QoS)
- Smart zoning
- Power-on self-test (POST) and diagnostics
- Switched Port Analyzer (SPAN) and Remote Switched Port Analyzer (RSPAN)

The following figure shows the Cisco MDS 9700 Series Supervisor-1E Module.

**Figure 8: Cisco MDS 9700 Series Supervisor-1E Module**

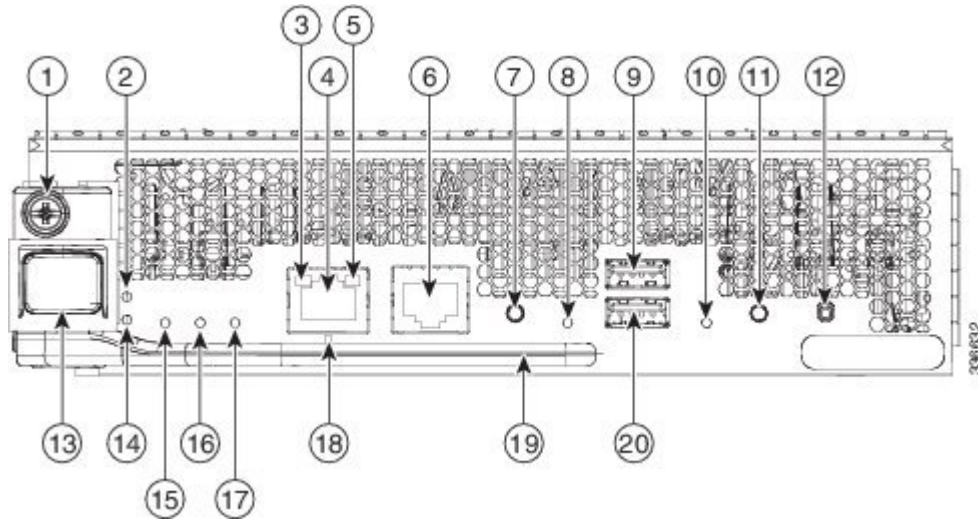

1	Module retaining screw
2	ID: locator LED
3	Link: management port link status LED
4	MGMT Ethernet: MGMT0 Ethernet out of band port
5	ACT: management port packet activity LED
6	Console Serial Port: module serial console port
7	Eject Request: eject request button for USB1 device
8	USB1: usb1 status LED
9	USB1 USB port
10	Slot0: slot0 status LED
11	Eject Request: eject request button for a slot0 device
12	Reset: module reset button
13	Module lock release button
14	Status: system diagnostic test status LED
15	System: system environment status LED
16	Active: supervisor redundancy status LED



17	PWR MGMT: system power status LED
18	Management port operational status LED
19	Module ejection lever
20	Slot0 USB port

The following table describes the LEDs on the Cisco MDS 9700 Series Supervisor-1E Module.

**Table 4: Cisco MDS 9700 Series Supervisor-1E Module LEDs**

LED	Status	Description
ID	Blinking blue	A user has activated this LED to allow a person to find the module.
	Off	Location identification is deactivated for this module.
Status	Green	All module diagnostics passed. The module is operational.
	Red	Indicates one of the following conditions: <ul style="list-style-type: none"> <li>• The module has detected an error and cannot power up.</li> <li>• The module is not properly inserted.</li> <li>• A bootup or runtime diagnostic test has failed.</li> </ul>
	Blinking Red	Indicates one of the following conditions: <ul style="list-style-type: none"> <li>• An over temperature condition has occurred. (This condition is not detected by an environmental monitoring.)</li> <li>• The module is resetting.</li> <li>• The ejector lever is open.</li> </ul>
	Off	The module is not receiving power.
System	Green	All environmental sensors in the system are within normal operating range.
	Amber	At least one power supply has failed or the power source is insufficient.
	Red	The temperature of the supervisor module exceeded the maximum allowed temperature.
	Off	The slot has detected a slot ID parity error.
Active	Green	The supervisor is operational and in the HA-active state.
	Amber	The supervisor module is in HA-standby state.
Power Management	Green	There is sufficient power available for all installed modules.
	Amber	There is insufficient power for all installed modules.

LED	Status	Description
MGMT0 Ethernet	Green	The mgmt0 interface is administratively active when the management port link is operational. From Cisco MDS NX-OS Release 8.4(2), when the supervisor is not administratively active.
	Amber	On Cisco MDS NX-OS Release 8.4(1a) or earlier, when the mgmt0 interface is not administratively active.
	Blinking amber	The management port link is bad and has been disabled.
	Off	The mgmt0 interface is uninitialized. No signal is detected.
ACT	Blinking Green	Frames are being transmitted or received by the interface.
	Off	There is no activity on the interface.
Link	Green	The management port link is operational.
	Off	No link signal received.
LOG FLASH	Green	The log flash CompactFlash or USB disk is being accessed.
	Off	The expansion flash CompactFlash or USB disk is not being accessed. This LED is off.
Slot0	Green	The log flash CompactFlash or USB disk is being accessed.
	Off	The expansion flash CompactFlash or USB disk is not being accessed. This LED is off.

## Cisco MDS 9700 Series Supervisor-1 Module

The Cisco MDS 9700 Series Supervisor-1 Module (DS-X97-SF1-K9) provides control and management functions for the Director switches and enables high-performance switching.

The Cisco MDS 9700 Series Supervisor-1 Module (DS-X97-SF1-K9) is designed specifically for the Cisco MDS 9706 and 9710 chassis.

The Cisco MDS 9700 Series Supervisor-1 Module supports the following features:

- Supports up to 384 2/4/8/10/16/32-Gbps Fiber Channel ports, or 1/10-Gbps FCoE ports in a single Cisco MDS 9710 Multilayer Director chassis
- Supports up to 192 2/4/8/10/16/32-Gbps Fiber Channel ports, or 1/10-Gbps FCoE ports in a single Cisco MDS 9706 Multilayer Director chassis
- Supports up to 192 40-Gbps FCoE ports in a single Cisco MDS 9710 Multilayer Director chassis
- Supports up to 96 40-Gbps FCoE ports in a single Cisco MDS 9706 Multilayer Director chassis
- Up to 24 terabits per second (Tbps) in a single Cisco MDS 9710 Multilayer Director chassis
- Up to 12 terabits per second (Tbps) in a single Cisco MDS 9706 Multilayer Director chassis
- Supports DS-X9710-FAB1 and DS-X9706-FAB1 crossbar fabric switching module on the Cisco MDS 9710 and 9706 Multilayer Directors respectively

- Multipathing based on Fabric Shortest Path First (FSPF)
- Nondisruptive software upgrades
- Provides high availability. The Cisco MDS 9700 Series Supervisor-1 Module has the ability to automatically restart failed processes, making it exceptionally robust. In the rare event that a supervisor module is reset, complete synchronization between the Active and Standby supervisor modules helps ensure a Stateful Failover with no disruption of traffic.
- Stateful process restart and failover
- Fully redundant operation
- Network management through the command-line interface (CLI) and through Cisco Data Center Network Manager (DCNM)
- Extensive security features including RADIUS and TACACS+, Fiber Channel Security Protocol (FC-SP), Secure File Transfer Protocol (SFTP), Secure Shell (SSH) Protocol, and Simple Network Management Protocol Version 3 (SNMPv3) implementing Advanced Encryption Standard (AES), VSANs, hardware-enforced zoning, ACLs, and per-VSAN role-based access control
- Support for virtual SAN (VSAN) technology and inter-VSAN routing (IVR)
- Network services such as access control lists (ACLs) and quality of service (QoS)
- Smart zoning
- Power-on self-test (POST) and diagnostics
- Switched Port Analyzer (SPAN) and Remote Switched Port Analyzer (RSPAN)

The following figure shows the Cisco MDS 9700 Series Supervisor-1 Module.

**Figure 9: Cisco MDS 9700 Series Supervisor-1 Module Front View**

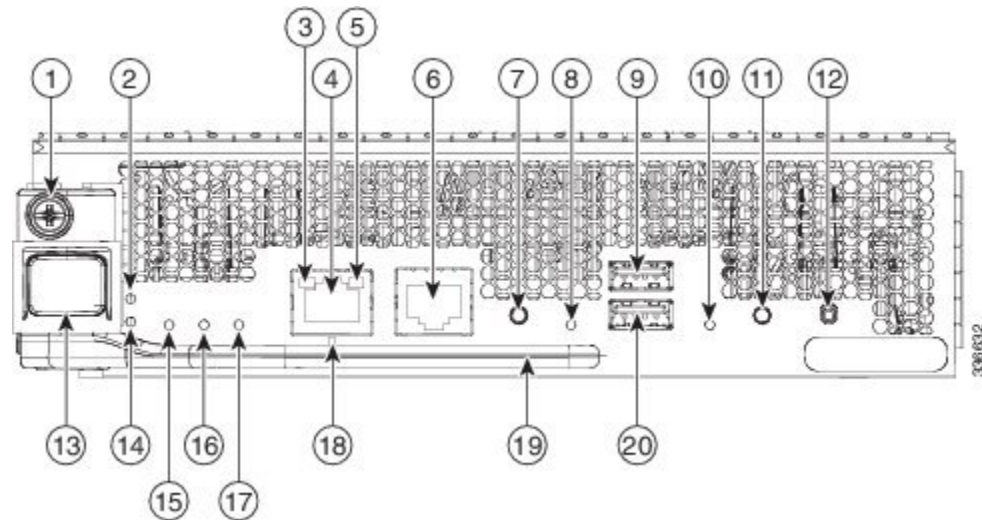

1	Module retaining screw
2	ID: locator LED
3	Link: management port link status LED

4	MGMT Ethernet: MGMT0 Ethernet out of band port
5	ACT: management port packet activity LED
6	Console Serial Port: module serial console port
7	Eject Request: eject request button for USB1 device
8	USB1: usb1 status LED
9	USB1: USB port (USB 3.0)
10	Slot0: slot0 status LED
11	Eject Request: eject request button for a slot0 device
12	Reset: module reset button
13	Module lock release button
14	Status: system diagnostic test status LED
15	System: system environment status LED
16	Active: supervisor redundancy status LED
17	PWR MGMT: system power status LED
18	Management port operational status LED
19	Module ejection lever
20	Slot0: USB port (USB 2.0)

The following table describes the LEDs on the Cisco MDS 9700 Series Supervisor-1 Module.

**Table 5: Cisco MDS 9700 Series Supervisor-1 Module LEDs**

LED	Status	Description
ID	Blinking blue	A user has activated this LED to allow a pers
	Off	Location identification is deactivated for this

LED	Status	Description
Status	Green	All module diagnostics passed. The module is operational.
	Red	Indicates one of the following conditions: <ul style="list-style-type: none"> <li>The module has detected an error and is in a failed state.</li> <li>The module is not properly inserted.</li> <li>A bootup or runtime diagnostic test failed.</li> </ul>
	Blinking Red	Indicates one of the following conditions: <ul style="list-style-type: none"> <li>An over temperature condition has occurred during an environmental monitoring test.</li> <li>The module is resetting.</li> <li>The ejector lever is open.</li> </ul>
	Off	The module is not receiving power.
System	Green	All environmental sensors in the system are operational.
	Amber	At least one power supply has failed or the temperature of the supervisor module is high.
	Red	The temperature of the supervisor module is high.
Active	Green	The supervisor is operational and in a HA state.
	Amber	The supervisor module is in a HA standby state.
Power Management	Green	There is sufficient power available for all installed modules.
	Amber	There is insufficient power for all installed modules.
MGMT0 Ethernet	Green	The mgmt0 interface is administratively active. From Cisco MDS NX-OS Release 8.4(2) onwards, the mgmt0 interface is not administratively active.
	Amber	On Cisco MDS NX-OS Release 8.4(1a) onwards, the mgmt0 interface is not administratively active.
	Off	The mgmt0 interface is uninitialized. No link signal received.
ACT	Green	Frames are being transmitted or received on the interface.
	Off	There is no activity on the interface.
Link	Green	The management port link is operational.
	Amber	The management port link has been disabled.
	Blinking amber	The management port has been disabled by the system.
	Off	No link signal received.

LED	Status	Description
USB1	Green	The flash device is mounted.
	Red	The device is a valid device type, but failed to format.
	Off	The flash device is not mounted and can be s
Slot0	Green	The flash device is mounted.
	Red	The device is a valid device type, but failed to format.
	Off	The flash device is not mounted and can be s

## Crossbar Fabric Switching Modules

In this section, details about the following crossbar fabric switching modules are provided:

### Cisco MDS 9718 Director Crossbar Fabric Switching Modules

The Cisco MDS 9718 Director supports up to six crossbar fabric (xbar) switching modules. The crossbar fabric switching modules, DS-X9718-FAB1 and DS-X9718-FAB3 are supported. The crossbar fabric switching modules are installed vertically at the back of the chassis behind the fan modules.

Crossbar fabric switching modules slots 1 and 2 are behind the fan module slot 1, the crossbar fabric switching modules slots 3 and 4 are behind the fan module slot 2, and crossbar fabric switching modules slots 5 and 6 are behind the fan module slot 3.

Cisco MDS 48-Port 32-Gbps Fiber Channel Switching Module needs a minimum of 6 (DS-X9718-FAB1) Crossbar Fabric-1 Switching Modules to deliver full bandwidth to all the modules in the switch. Each DS-X9718-FAB1 Crossbar Fabric-1 Switching Module provides 256-Gbps of fiber channel bandwidth per slot.

Cisco MDS 48-Port 32-Gbps Fiber Channel Switching Module needs a minimum of 3 (DS-X9718-FAB3) Crossbar Fabric-3 Switching Modules to deliver full bandwidth to all the modules in the switch. Each DS-X9718-FAB3 Crossbar Fabric-3 Switching Module provides 512-Gbps of fiber channel bandwidth per slot. A fourth crossbar fabric switching module is required for N+1 protection.

The DS-X9718-FAB1 Crossbar Fabric-1 Switching Modules are supported from Cisco MDS NX-OS Release 7.3(1) or later. DS-X9718-FAB1 modules are supported only with Supervisor-1E Modules (DS-X97-SF1E-K9).

The DS-X9718-FAB3 Crossbar Fabric-3 Switching Modules are supported from Cisco MDS NX-OS Release 8.4(2a) or later. DS-X9718-FAB3 modules are supported only with Supervisor-4 Module (DS-X97-SF4-K9).





---

**Note** You cannot have a mix of different supervisor modules or a mix of different crossbar fabric switching modules in a chassis, except during migration of a supervisor module or a crossbar fabric switching module.

---

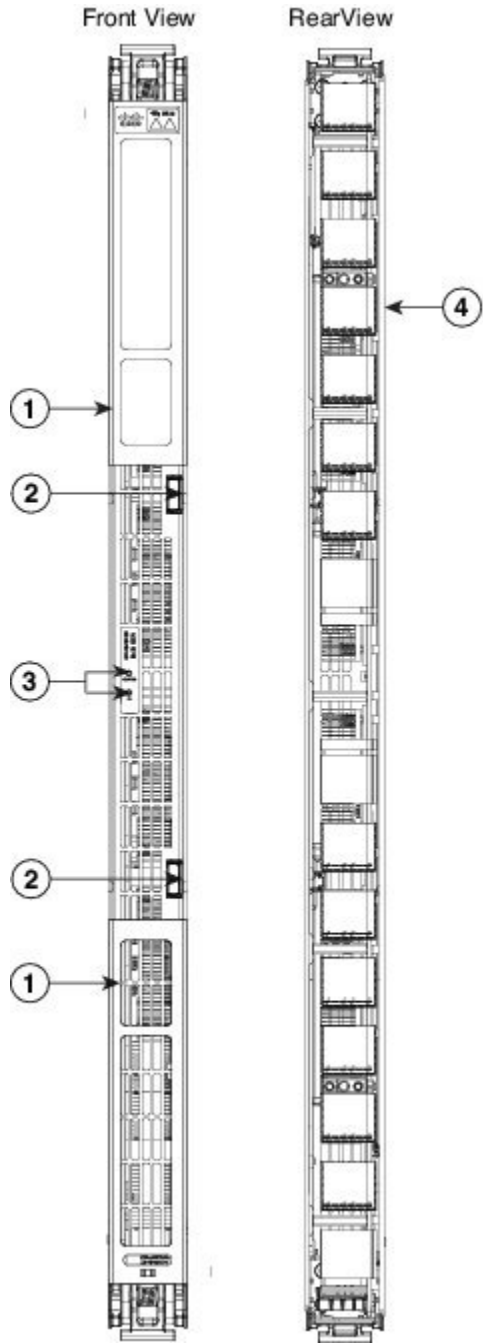
Figure 10: Cisco MDS 9718 Crossbar Fabric Switching Module



1	Locking lever
2	Unlocking button
3	Crossbar fabric switching module LEDs
4	Connector pins

The LEDs on the crossbar fabric switching modules indicate the status of the modules. The table shown below describes the LEDs.

**Table 6: Cisco MDS 9718 Director Crossbar Modules LEDs**

LED	Status	Description
Status	Green	All diagnostics pass. The module is operational (no error).
	Red	Indicates one of the following: <ul style="list-style-type: none"> <li>• The diagnostic test has failed. The module is not operational during the initialization sequence.</li> <li>• The inlet air temperature of the system has exceeded the threshold (a major environmental warning). The module is damaged.</li> </ul>
	Blinking Red	Indicates one of the following: <ul style="list-style-type: none"> <li>• The crossbar fabric switching module has just been inserted.</li> <li>• An over temperature condition has occurred and the module is not operational.</li> <li>• The power was turned off with a CLI command.</li> <li>• The module is resetting and both ejector levers are open.</li> </ul>
	Off	The module is not receiving power.
Locator ID	Blinking Blue	The operator has activated this LED to identify this module.
	Off	Operator has not flagged this card for identification.

Since the crossbar fabric switching modules are located behind the fan modules in the chassis, the LEDs on the crossbar fabric switching modules are not easily visible from the back of the chassis. So, crossbar fabric switching module status LEDs are provided on the fan modules as well. Since each fan module covers two crossbar fabric switching modules, the status LEDs for the two crossbar fabric switching modules are present on each fan module. If the fan module is removed the status and locator LEDs on crossbar fabric switching modules will be visible.

When a crossbar fabric switching module needs to be located, the locator LED of the corresponding fan module needs to be activated, followed by the locator LED of the crossbar fabric switching module, using the CLIs **locator-led fan** < fan module number > and **locator-led xbar** < xbar slot number >. For example, to locate a crossbar fabric switching module in slot 4, the locator LED of the fan module 2 needs to be activated followed by the locator LED of the crossbar fabric switching module 4.

## Cisco MDS 9710 Director Crossbar Fabric Switching Modules

The Cisco MDS 9710 Director supports up to six crossbar (xbar) fabric switching modules. The crossbar fabric switching modules DS-X9710-FAB1 and DS-X9710-FAB3 are supported. The crossbar fabric switching modules are installed vertically at the back of the chassis behind the fan modules.

Crossbar fabric switching modules slots 1 and 2 are behind the fan module slot 1, the crossbar fabric switching modules slots 3 and 4 are behind the fan module slot 2, and crossbar fabric switching modules slots 5 and 6 are behind the fan module slot 3.



Cisco MDS 48-Port 32-Gbps Fiber Channel Switching Module needs a minimum of 6 (DS-X9710-FAB1) Crossbar Fabric-1 Switching Modules to deliver full bandwidth to all the modules in the switch. Each DS-X9710-FAB1 Crossbar Fabric-1 Switching Module provides 256-Gbps of fiber channel bandwidth per slot.

Cisco MDS 48-Port 32-Gbps Fiber Channel Switching Module needs a minimum of 3 (DS-X9710-FAB3) Crossbar Fabric-3 Switching Modules to deliver full bandwidth to all the modules in the switch. Each DS-X9710-FAB3 Crossbar Fabric-3 Switching Module provides 512-Gbps of fiber channel bandwidth per slot. A fourth crossbar fabric switching module is required for N+1 protection.

The DS-X9710-FAB1 crossbar fabric switching module is supported from Cisco MDS NX-OS Release 6.2(1) or later. DS-X9710-FAB1 modules are supported only with Supervisor-1 Modules (DS-X97-SF1-K9).

The DS-X9710-FAB3 crossbar fabric switching module is supported from Cisco MDS NX-OS Release 8.4(1) or later. DS-X9710-FAB3 modules are supported only with Supervisor-4 Modules (DS-X97-SF4-K9).



---

**Note** You cannot have a mix of different supervisor modules or a mix of different crossbar fabric switching modules in a chassis, except during migration of a supervisor module or a crossbar fabric switching module.

---

Figure 11: Cisco MDS 9710 Crossbar Fabric Switching Module

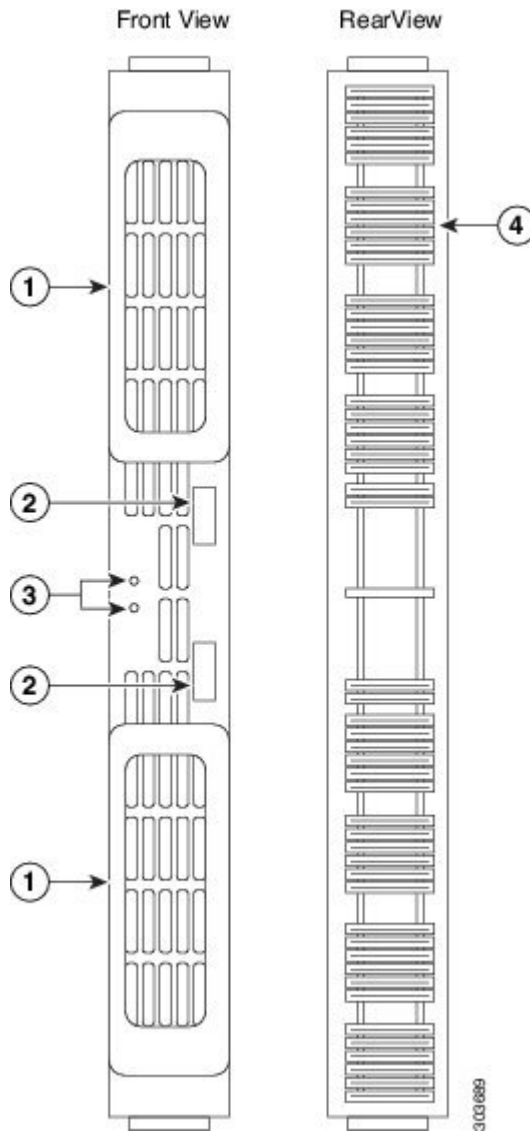

1	Locking lever
2	Unlocking button
3	Crossbar fabric switching module LEDs
4	Connector pins

The LEDs on the crossbar fabric switching modules indicate the status of the modules. The table below describes the LEDs.

Table 7: Cisco MDS 9710 Director Crossbar Fabric Switching Modules LEDs

LED	Status	Description
Status	Green	All diagnostics pass. The module is operational (normal sequence).
	Orange	One of the following occurs: <ul style="list-style-type: none"> <li>The module is booting or running diagnostics (normal sequence).</li> <li>An over temperature condition occurred (a minor temperature exceeded during environmental monitoring).</li> </ul>
	Red, Blinking	One of the following occurs: <ul style="list-style-type: none"> <li>The diagnostic test failed. The module is not operational. A major fault occurred during the initialization sequence.</li> <li>An over temperature condition occurred (a major temperature exceeded during environmental monitoring).</li> <li>Crossbar fabric switching module has been manually reset.</li> </ul>
	Red	Bad slot ID parity.
	Off	The module is not receiving power.
Locator ID	Blue Blinking	Operator has flagged this card for identification.
	Off	Operator has not flagged this card for identification.

Since the crossbar fabric switching modules are located behind the fan modules in the chassis, the LEDs on the crossbar fabric switching modules are not easily visible from the back of the chassis. So, crossbar fabric switching module status LEDs are provided on the fan modules as well. Each fan module covers two crossbar fabric switching modules, the status LEDs for the two crossbar fabric switching modules are present on each fan module. If the fan module is removed, the status and locator LEDs on the crossbar fabric switching modules will be visible.

When a fabric module needs to be located, the locator LED of the corresponding fan module must be activated, followed by the locator LED of the crossbar fabric switching module, using the CLIs **locator-led fan** < fan module number > and **locator-led xbar** < xbar slot number >. For example, to locate the crossbar fabric switching module in slot 4, the locator LED of the fan module 2 needs to be activated followed by the locator LED of the crossbar fabric switching module 4.

## Cisco MDS 9706 Director Crossbar Fabric Switching Modules

The Cisco MDS 9706 Director supports up to six crossbar (xbar) fabric switching modules. The crossbar fabric switching modules DS-X9706-FAB1 and DS-X9706-FAB3 are supported. The crossbar fabric switching modules are installed vertically at the back of the chassis behind the fan modules. Crossbar fabric switching modules slots 1 and 2 are behind the fan module slot 1, crossbar fabric switching modules slots 3 and 4 are behind the fan module slot 2, and crossbar fabric switching modules slots 5 and 6 are behind the fan module slot 3.

Cisco MDS 48-Port 32-Gbps Fiber Channel Switching Module needs a minimum of 6 (DS-X9706-FAB1) Crossbar Fabric-1 Switching Modules to deliver full bandwidth to all the modules in the switch. Each DS-X9706-FAB1 Crossbar Fabric-1 Switching Module provides 256-Gbps of fiber channel bandwidth per slot.

Cisco MDS 48-Port 32-Gbps Fiber Channel Switching Module needs a minimum of 3 (DS-X9706-FAB3) Crossbar Fabric-3 Switching Modules to deliver full bandwidth to all the modules in the switch. Each DS-X9706-FAB3 Crossbar Fabric-3 Switching Module provides 512-Gbps of fiber channel bandwidth per slot. A fourth crossbar fabric switching module is required for N+1 protection.

The DS-X9706-FAB1 crossbar fabric switching module is supported from Cisco MDS NX-OS Release 6.2(9) or later. DS-X9706-FAB1 modules are supported only with Supervisor-1 Modules (DS-X97-SF1-K9).

The DS-X9706-FAB3 crossbar fabric switching module is supported from Cisco MDS NX-OS Release 8.4(1) or later. DS-X9706-FAB3 modules are supported only with Supervisor-4 Modules (DS-X97-SF4-K9).



---

**Note** You cannot have a mix of different supervisor modules or a mix of different crossbar fabric switching modules in a chassis, except during migration of a supervisor module or a crossbar fabric switching module.

---

Figure 12: Cisco MDS 9706 Crossbar Fabric Switching Module

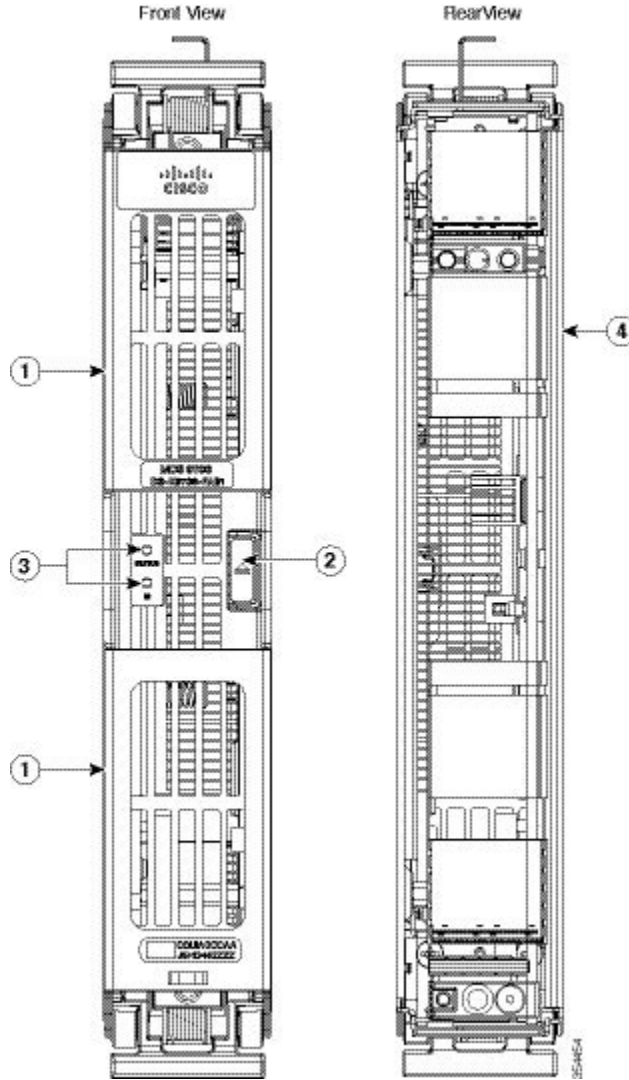

1	Locking lever	3	Crossbar fabric switching module LEDs
2	Unlocking button	4	Connector pins

The LEDs on the crossbar fabric switching modules indicate the status of the modules. The table below describes the LEDs.

Table 8: Cisco MDS 9706 Director Crossbar Fabric Switching Modules LEDs

LED	Status	Description
Status	Green	All diagnostics pass. The module is operational (normal initialization sequence).
	Orange	One of the following occurs: <ul style="list-style-type: none"> <li>The module is booting or running diagnostics (normal initialization sequence).</li> <li>An over temperature condition occurred (a minor threshold was exceeded during environmental monitoring).</li> </ul>
	Red, Blinking	One of the following occurs: <ul style="list-style-type: none"> <li>The diagnostic test failed. The module is not operational because a fault occurred during the initialization sequence.</li> <li>An over temperature condition occurred (a major threshold was exceeded during environmental monitoring).</li> <li>Crossbar fabric switching module has been manually powered off.</li> </ul>
	Red	Bad slot ID parity.
	Off	The module is not receiving power.
Locator ID	Blue Blinking	Operator has flagged this card for identification.
	Off	Operator has not flagged this card for identification.

The crossbar fabric switching modules are located behind the fan modules in the chassis, the LEDs on the crossbar fabric switching module are not easily visible from the back of the chassis. So, the crossbar fabric switching module status LEDs are provided on the fan modules as well. Each fan module covers two crossbar fabric switching modules, the status LEDs for two crossbar fabric modules are present on each fan module. If the fan module is removed, the status and locator LEDs on the crossbar fabric switching modules will be visible.

When a crossbar fabric switching module needs to be located, the locator LED of the corresponding fan module must be activated, followed by the locator LED of fabric module, using the CLIs **locator-led fan** < fan module number > and **locator-led xbar** < xbar slot number >. For example, to locate the crossbar fabric switching module in slot 4, the locator LED of the fan module 2 needs to be activated followed by the locator LED of the crossbar fabric switching module 4.

## Fiber Channel Switching Modules

In this section, the following fiber channel switching modules are discussed:

### Cisco MDS 48-Port 64-Gbps Fiber Channel Switching Module

The Cisco MDS 9700 48-Port 64-Gbps Fiber Channel Switching Module is designed specifically for the Cisco MDS 9700 Multilayer Director Switches. With 64-Gbps Fiber Channel ports, the 64-Gbps 48 port Fiber

Channel Switching Module meets the high performance needs for flash memory and Non-Volatile Memory Express (NVMe) over Fiber Channel SANs. The switching module has a built in Network Processing Unit (NPU) for inline analytics. This module also supports hot-swappable Enhanced Small Form-Factor Pluggable (SFP+) transceivers.

Individual ports can be configured with Cisco 64-Gbps, 32-Gbps, and 16-Gbps SFP+ transceivers. Each port supports 1000 buffer credits when configured as E port. With the Cisco Enterprise Package license, up to 16000 buffer credits can be allocated to an individual port when all other ports in the port group are configured with minimum BB credits, enabling full link bandwidth over long distances with no degradation in link utilization.



**Note** Cisco MDS 9700 Series Supervisor-4 Module (DS-X97-SF4-K9) and Cisco MDS Crossbar Fabric-3 Switching Modules (depending on the chassis type) are required for Cisco MDS 9700 48-Port 64-Gbps Fiber Channel Switching Module to function.

In Cisco MDS NX-OS Release 9.2(1), the SAN Analytics feature is not supported on Cisco MDS 9700 48-Port 64-Gbps Fiber Channel Switching Module.

For more information on the Cisco MDS 48-Port 64-Gbps Fiber Channel Switching Module, see the [Cisco MDS 9700 48-Port 64-Gbps Fibre Channel Switching Module datasheet](#).



**Note** The 64-Gbps module supports Forward Error Correction (FEC) on links configured for 16-Gbps speed only with Transmitter Training Signal (TTS). This is a change from the 16 Gbps and 32 Gbps Fiber Channel modules. For more information, see the [Cisco MDS 9000 Series Interfaces Configuration Guide, Release 9.x](#).

The following figure shows a Cisco MDS 48-Port 64-Gbps Fiber Channel Switching Module.

**Figure 13: Cisco MDS 48-Port 64-Gbps Fiber Channel Switching Module**

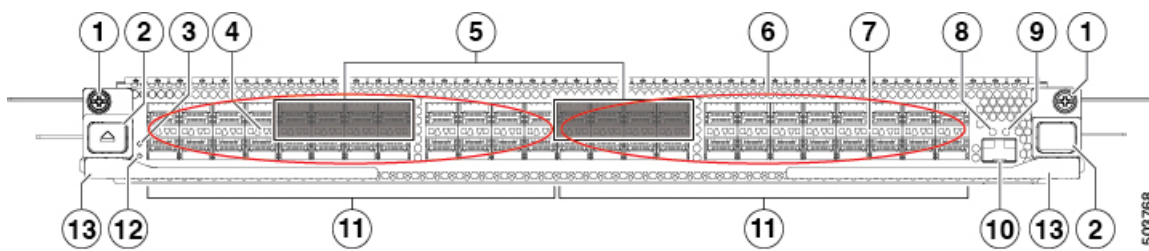

1	Detention screw (2)
2	Unlocking button (2)
3	Locator LED
4	FC port status LEDs (48)
5	Fiber Channel encryption ports <sup>1</sup> (8)
6	Airflow grill
7	FC ports (48 x 4/8/16/32/64 Gbps, pluggable SFP and SFP+ compatible)
8	Analytics port link status LED

9	Analytics port link activity LED
10	Ethernet Analytics port <sup>2</sup> (1 Gbps, pluggable SFP compatible)
11	Fiber Channel port group. A port group consists of 24 ports.
12	Status LED
13	Ejector levers (2)

<sup>1</sup> Encryption ports support AES 128-bit link-level encryption. Support for AES 256-bit encryption will be added in future releases.

<sup>2</sup> Not operational (supported in future releases).

The following table describes the LEDs for the 48-Port 64-Gbps Fiber Channel Switching Module.

**Table 9: Cisco MDS 48-Port 64-Gbps Fiber Channel Switching Module LEDs**

LED	Status	Description
Status	Green	All diagnostic tests passed. The module is operational (normal initialization sequence).
	Blinking Red	One of the following conditions exist: <ul style="list-style-type: none"> <li>• The module is resetting. The switch has been powered on or the module has been hot inserted during the normal initialization sequence.</li> <li>• The module is resetting and ejector levers are out.</li> <li>• The module does not have sufficient power.</li> <li>• An over temperature condition has occurred. (A major temperature threshold has been exceeded during environmental monitoring.)</li> <li>• The module failed to download code and configure information successfully during the initial reset, the module does not come online.</li> </ul>
	Solid Red	One of the following conditions exist: <ul style="list-style-type: none"> <li>• The module has detected a slot ID parity error on the mid plane. The module cannot determine its slot number and will not respond to the supervisor.</li> <li>• The module has failed diagnostics tests and has powered off.</li> </ul>
	Off	The module is not receiving power.



LED	Status	Description
Locator	Blinking Blue	The operator has activated this LED via the <b>locator-led</b> command to identify this module in the chassis.
	Off	The operator has not activated this LED via the <b>locator-led</b> command.
Link	Green	The port is active (the link is connected and operational).
	Solid Orange	The port is disabled by the administrator or is not initializing.
	Blinking Orange	The port is faulty and has been automatically disabled by the software.
	Off	The port is not active or the link is not connected.

## Cisco MDS 48-Port 32-Gbps Fiber Channel Switching Module

The Cisco MDS 9700 48-Port 32-Gbps Fiber Channel Switching Module is designed specifically for the Cisco MDS 9700 Multilayer Director Switches. With 768 line-rate 32-Gbps Fiber Channel ports per director, the 32-Gbps 48 port Fiber Channel Switching Module meets the high-performance needs for flash-memory and Non-Volatile Memory Express (NVMe) over Fiber Channel workloads. The switching module has built-in network processing unit for inline analytics. This module also supports hot-swappable Enhanced Small Form-Factor Pluggable (SFP+) transceivers.

Individual ports can be configured with Cisco 32-Gbps, 16-Gbps, and 8-Gbps SFP+ transceivers. Each port supports 500 buffer credits when configured as E port for exceptional extensibility without the need for additional licenses. With the Cisco Enterprise Package license, up to 8170 buffer credits can be allocated to an individual port when all other ports in the port group are configured with minimum BB credit, enabling full link bandwidth over long distances with no degradation in link utilization.

For more information on the Cisco MDS 48-Port 32-Gbps Fiber Channel Switching Module, see the [Cisco MDS 9700 48-Port 32-Gbps Fibre Channel Switching Module Data Sheet](#).

Figure 14: Cisco MDS 48-Port 32-Gbps Fiber Channel Switching Module

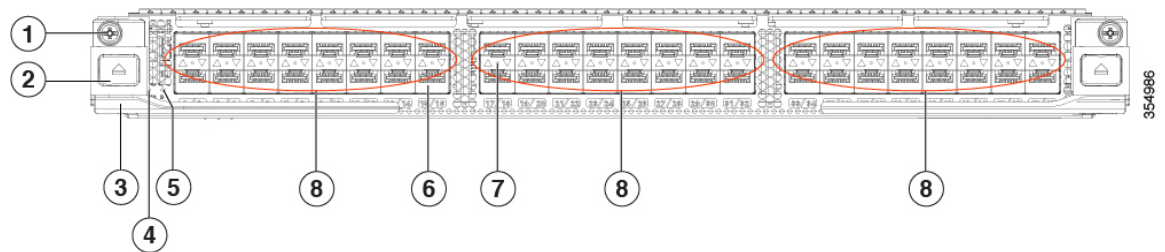

1	Detention screw	5	Locator LED
2	Unlocking button	6	FC ports
3	Ejector Lever	7	Link LEDs

4	Status LED	8	Fiber Channel port group. A port group consists of 16 ports.
---	------------	---	--

The following table describes the LEDs for the 48-Port 32-Gbps Fiber Channel Switching Module.

**Table 10: Cisco MDS 48-Port 32-Gbps Fiber Channel Switching Module LEDs**

LED	Status	Description
Status	Green	All diagnostics pass. The module is operational (normal initialization sequence).
	Orange	One of the following occurs or occurred: <ul style="list-style-type: none"> <li>The module is booting or running diagnostics (normal initialization sequence).</li> <li>An over temperature condition has occurred. (A minor temperature threshold has been exceeded during environmental monitoring.)</li> </ul>
	Blinking Red	One of the following occurs: <ul style="list-style-type: none"> <li>The module is resetting. The switch has been powered on or the module has been hot inserted during the normal initialization sequence.</li> <li>An over temperature condition has occurred. (A major temperature threshold has been exceeded during environmental monitoring.)</li> <li>If the module fails to download code and configuration information successfully during the initial reset, the LED stays blinking red; the module does not come online.</li> </ul>
	Solid Red	The module has detected a slot ID parity error on the mid plane. The module cannot determine its slot number and will not respond to the supervisor.
	Off	The module is not receiving power.
ID	Blinking blue	The operator has activated this LED to identify this module in the chassis.
	Off	This module is not selected.
Link	Green	The port is active (the link is connected and operational).
	Solid Orange	SFP is not present or Admin is down.
	Blinking Orange	A fault condition exists.
	Off	The port is not active or the link is not connected.

## Cisco MDS 48-Port 16-Gbps Fiber Channel Switching Module

The Cisco MDS 9700 48-Port 16-Gbps Switching Module is designed specifically for the Cisco MDS 9700 Series Director Switches. These modules are hot-swappable and compatible with 2, 4, 8, 10, and 16-Gbps interfaces, and they support hot-swappable Enhanced Small Form-Factor Pluggable (SFP+) transceivers.

The FC switching module has 12, 4-port, port groups. Each port group is capable of a speed of 64-Gbps in each direction simultaneously. The ports of this switching module support expansion port (E port), fabric port (F port), fabric loop port (FL port), SPAN destination port (SD port), and (TE port) port mode.

Individual ports can be configured with Cisco 16-Gbps, 8-Gbps, or 10-Gbps shortwave or longwave SFP+ transceivers. Each port that is configured as mode E supports 500 buffer credits with no additional licensing required. With the Cisco Enterprise Package, up to 4095 buffer credits can be allocated to an individual port.

The FC switching module also provides Cisco VMpath technology that enables advanced virtual machine-aware SAN provisioning and monitoring for virtualized data centers. With Cisco VMpath, you can monitor, manage, and control SAN resource allocation and performance on a per-virtual machine basis and map out paths from the server to storage.

The FC switching module is hot-swappable and has hot-swappable SFP+ transceivers. It includes online diagnostics, stateful process restart, and nondisruptive supervisor failover. In addition, the FC switching module has any module, any port configuration for port channels, fabric-based multipathing, per-VSAN fabric services, and port tracking. The module also supports Virtual Routing Redundancy Protocol (VRRP) for management.

The Cisco MDS 9700 48-Port 16-Gbps Fiber Channel Switching Module provides the following features:

- Configuration file management
- Nondisruptive software upgrades for FC interfaces
- Call Home
- Power-management LEDs
- Port beaconing
- System LED
- SNMP traps for alerts
- Network boot

The following figure shows a 48-Port 16-Gbps Fiber Channel Switching Module. The front panel connectors support standard modular SFP+ transceivers and the speed detection is autosensing.

**Figure 15: 48-Port 16-Gbps Fiber Channel Switching Module**

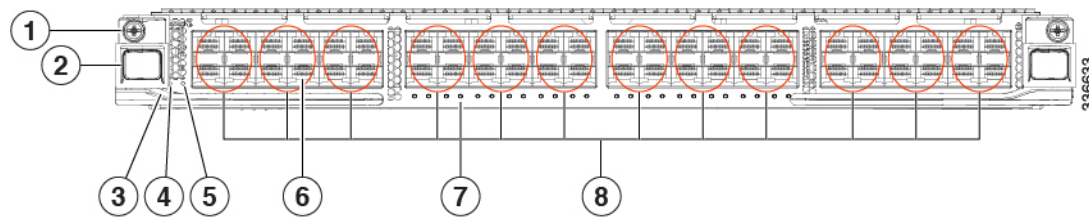

<b>1</b>	Detent screw	<b>5</b>	Locator LED
<b>2</b>	Unlocking button	<b>6</b>	Fiber Channel ports
<b>3</b>	Ejector Lever	<b>7</b>	Link LEDs
<b>4</b>	Status LED	<b>8</b>	Fiber Channel port group. A port group consists of 4 ports.

The following table describes the LEDs for the 48-Port 16-Gbps Fiber Channel Switching Module.

LED	Status	Description
Status	Green	All diagnostics pass. The module is operational (normal initialization sequence).
	Orange	One of the following occurs or occurred: <ul style="list-style-type: none"> <li>The module is booting or running diagnostics (normal initialization sequence).</li> <li>The inlet air temperature of the system has exceeded the maximum system operating temperature limit (a minor environmental warning). To ensure maximum product life, you should immediately correct the environmental temperature and restore the system to normal operation.</li> </ul>
	Red	One of the following occurs: <ul style="list-style-type: none"> <li>The diagnostic test failed. The module is not operational because a fault occurred during the initialization sequence.</li> <li>The inlet air temperature of the system has exceeded the safe operating temperature limits of the card (a major environmental warning). The card has been shut down to prevent permanent damage.</li> </ul>
ID	Blinking blue	The operator has activated this LED to identify this module in the chassis.
	Off	This module is not being identified.
Link	Solid green	Link is up.
	Intermittent blinking green	Link is up (traffic on port).
	Solid orange	SFP is not present or Admin is down.
	Blinking orange	A fault condition exists.
	Off	The port is not active or the link is not connected.

## SAN Extension Modules

The following section describes the Cisco MDS 9000 SAN extension modules.

### Cisco MDS 24/10 port SAN Extension Module

The Cisco MDS 24/10 port SAN Extension Module provides a high performance, flexible, unified platform for deploying enterprise class disaster recovery and business continuance SAN extension solutions. The MDS 24/10 port SAN Extension Module is supported on Cisco MDS 9700 Series Multilayer Director Switches. With 24 line rate 2-, 4-, 8-, 10-, and 16-Gbps Fiber Channel ports and eight 1 and 10GE or two 40GE Fiber Channel over IP (FCIP) ports, this module enables large and scalable deployment of SAN extension solutions.

The SAN extension module has two independent service engines that can each be individually and incrementally enabled to scale as business requirements expand. The SAN extension module supports the full range of services available on other Cisco MDS 9000 Family Fiber Channel switching modules, including virtual SAN (VSAN), security, and traffic management services. The FCIP module uses Cisco expertise and knowledge of IP networks to deliver outstanding SAN extension performance, reducing latency for disk and tape operations with FCIP acceleration features, including FCIP write acceleration and FCIP tape write and read acceleration. Hardware-based encryption helps secure sensitive traffic with IP Security (IPsec), and hardware-based compression dramatically enhances performance for both high and low speed links, enabling immediate cost savings in expensive WAN infrastructure. Multiple FCIP interfaces within a single engine or across service engines can be grouped into a port channel of up to 16 links for high availability and increased aggregate throughput.

For more information on the Cisco MDS 24/10 Port SAN Extension Module, see the Cisco MDS 9000 24/10 port SAN Extension Module for Cisco MDS 9700 Series Multilayer Directors Datasheet.



**Note** 40GE IP Storage interfaces are supported from Cisco MDS NX-OS Release 8.5(1) or later releases.

The following figure shows a Cisco MDS 24/10 Port SAN Extension Module.

**Figure 16: Cisco MDS 24/10 Port SAN Extension Module**

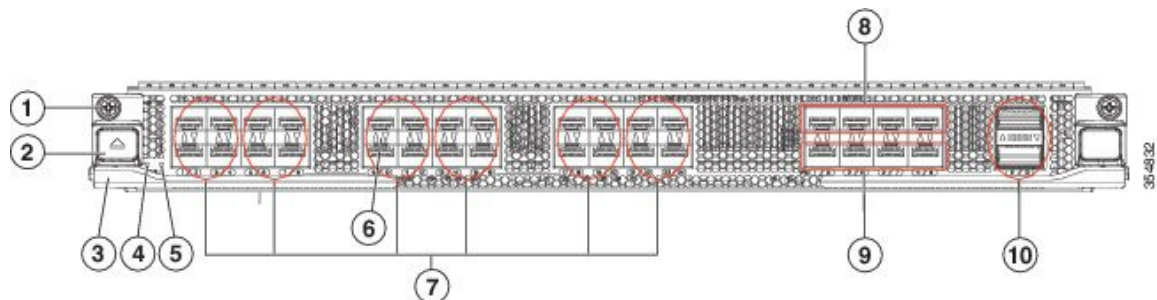

<b>1</b>	Detention screw	<b>6</b>	Link LEDs
<b>2</b>	Unlocking button	<b>7</b>	Fiber Channel port group. A port group consists of four ports. 16-Gbps ports.
<b>3</b>	Ejector Lever	<b>8, 9</b>	10-G IPS port group. A port group consists of four ports.
<b>4</b>	Status LED	<b>10</b>	40-G IPS port group. A port group consists of two ports.
<b>5</b>	Locator LED		

The following table describes the LEDs for the 24/10 port SAN extension module.

Table 11: Cisco MDS 9700 Series 24/10 Port SAN Extension Module LEDs

LED	Status	Description
Status	Green	All diagnostics pass. The module is operational (normal initialization sequence).
	Orange	One of the following occurs or occurred: <ul style="list-style-type: none"> <li>The module is booting or running diagnostics (normal initialization sequence).</li> <li>An over temperature condition has occurred. (A minor temperature threshold has been exceeded during environmental monitoring.)</li> </ul>
	Blinking Red	One of the following occurs: <ul style="list-style-type: none"> <li>The module is resetting. The switch has just been powered on or the module has been hot inserted during the normal initialization sequence.</li> <li>An over temperature condition has occurred (a major temperature threshold has been exceeded during environmental monitoring).</li> <li>If the module fails to download the code and configuration information successfully during the initial reset, the LED stays blinking red; the module does not come online.</li> </ul>
	Solid Red	The module has detected a slot ID parity error on the mid plane. The module cannot determine its slot number and hence will not respond to the Supervisor.
ID	Blinking blue	The operator has activated this LED to identify this module in the chassis.
	Off	This module is not being identified.
Link	Solid green	Link is up.
	Steady Blinking Green	Port Beacon On (beacon is used to identify port).
	Intermittent Blinking Green	Link is up (traffic on port).
	Solid Orange	SFP is not present or Admin is down.
	Blinking Orange	A fault condition exists.
	Off <sup>3</sup>	The port is not active or the link is not connected.

<sup>3</sup> The Link LED status of IP Storage ports indicates Solid Orange when an SFP is present and the link is not connected.

## Fiber Channel over Ethernet Switching Modules

The following section describes the fiber channel over Ethernet switching modules.

## Cisco MDS 24-Port 40-Gbps Fiber Channel over Ethernet Module

The next-generation Cisco MDS 24-Port 40-Gigabit Fiber Channel over Ethernet (FCoE) Module (DS-X9824-960K9) provides Cisco Unified fabric connectivity to the SAN core. It empowers mid-size and large enterprises that are rapidly deploying cloud-scale applications with Inter-Switch Link (ISL) consolidation, four times the bandwidth, and exceptional investment protection for their SANs. The data center fabric is already using 40-Gbps connectivity in the core for more efficient convergence, higher performance, and lower total cost of ownership (TCO). With the entire Cisco Nexus® Family supporting 40-Gbps FCoE, this capability can now be extended to the SAN core. You can extend the benefits of FCoE beyond the access layer to the data center core with a full line-rate FCoE module for the Cisco MDS 9700 Series Multilayer Directors.

For more information on the Cisco MDS 24-Port 40-Gbps FCoE Module, see the [Cisco MDS 9700 24 Port 40 Gbps Fiber Channel over Ethernet Module Datasheet](#).

The following figure shows a Cisco MDS 24-Port 40-Gigabit Fiber Channel over Ethernet module.

**Figure 17: Cisco MDS 24-Port 40-Gbps FCoE Module**

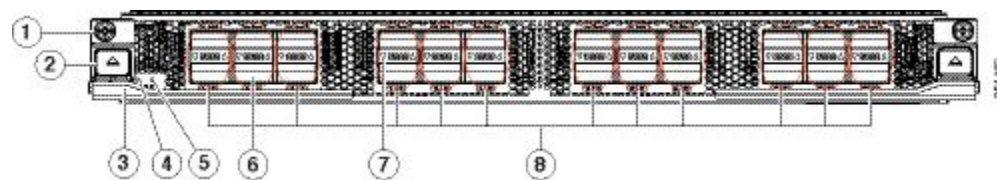

<b>1</b>	Detention screw	<b>5</b>	Locator LED
<b>2</b>	Unlocking button	<b>6</b>	FCoE ports
<b>3</b>	Ejector Lever	<b>7</b>	Link LEDs
<b>4</b>	Status LED	<b>8</b>	FCoE port group. Each port group consists of two ports.

The following table describes the LEDs for the 24-Port 40-Gbps Fiber Channel over Ethernet module.

Table 12: Cisco MDS 9700 Series 24-Port 40-Gbps FCoE Module LEDs

LED	Status	Description
Status	Green	All diagnostics pass. The module is operational (normal initialization sequence).
	Orange	One of the following occurs or occurred: <ul style="list-style-type: none"> <li>The module is booting or running diagnostics (normal initialization sequence).</li> <li>The inlet air temperature of the system has exceeded the maximum system operating temperature limit (a minor environmental warning). To ensure maximum product life, you should immediately correct the environmental temperature and restore the system to normal operation.</li> </ul>
	Red	One of the following occurs: <ul style="list-style-type: none"> <li>The diagnostic test failed. The module is not operational because a fault occurred during the initialization sequence.</li> <li>The inlet air temperature of the system has exceeded the safe operating temperature limits of the card (a major environmental warning). The card has been shut down to prevent permanent damage.</li> </ul>
ID	Blinking blue	The operator has activated this LED to identify this module in the chassis.
	Off	This module is not being identified.
Link	Solid green	Link is up.
	Solid orange	SFP is not present or Admin is down.
	Blinking Orange	A fault condition exists.
	Off	The port is not active or the link is not connected.

## Cisco MDS 48-Port 10-Gbps Fiber Channel over Ethernet Module

The Cisco MDS 48-Port 10-Gbps Fiber Channel over Ethernet module (DS-X9848-480K9) is designed for the MDS 9700 Series Directors. These modules are hot-swappable and they support 10-Gigabit Fiber Channel over Ethernet ports in SFP+ form factor.

The Cisco MDS 48-Port 10-Gbps Fiber Channel over Ethernet module delivers integrated Fiber Channel over Ethernet (FCoE), simplifies the network infrastructure, and helps reduce costs. The FCoE module allows you to extend the existing Fiber Channel SANs by using FCoE. The Cisco MDS 48-Port 10-Gigabit Fiber Channel over Ethernet module supports connectivity to FCoE switching platforms and to FCoE targets. This module also supports connectivity to FCoE initiators and targets that only send FCoE traffic.

The Cisco MDS 48-Port 10-Gbps Fiber Channel over Ethernet module has the MPC8572 processor and 2 GB DDR3 SDRAM. The module delivers 720 million packets per second (MPPS) and is capable of 480-Gbps of data throughput. This module can power down data path slices to save power when the attached ports are not in use.



The Cisco MDS 9700 10-Gbps 48-Port FCoE module provides the following features:

- High performance—Cisco MDS 9700 Series architecture, based on central arbitration and crossbar fabric switching module provides 10-Gbps line-rate, nonblocking, predictable performance across all traffic conditions for every FCoE port in the chassis.
- Efficient encoding—FCoE takes advantage of the more efficient encoding mechanisms of 10-Gbps Ethernet to provide 50-percent more bandwidth than 8-Gbps Fiber Channel (the actual throughput of 8-Gbps Fiber Channel is 6.8 Gbps). Therefore, you need fewer 10-Gigabit Ethernet links to achieve the same bandwidth as with multiple 8-Gbps links.
- High availability—The Cisco MDS 9700 Series provides outstanding availability and reliability. The Cisco MDS 9710 Multilayer Director is the industry's first director-class switch that enables redundancy on all major components, including the fabric card. It provides grid redundancy on the power supply and 1+1 redundant supervisors. Users can add fabric cards to enable N+1 fabric redundancy.
- Scalability—The Cisco MDS 9700 48-Port 10-Gbps FCoE Module provides the scalability of 384 10-Gbps full line-rate autosensing ports in a single chassis, or up to 1152 ports in a single rack.
- Intelligent network services—VSAN technology, access control lists (ACLs) for hardware-based intelligent frame processing, and fabric-wide quality of service (QoS) enable migration from SAN islands to enterprise-wide storage networks.
- Sophisticated diagnostics—The Cisco MDS 9700 48-Port 10-Gbps FCoE Module provides intelligent diagnostics, protocol decoding, and network analysis tools as well as integrated Cisco Call Home capability for greater reliability, faster problem resolution, and reduced service costs.

The Cisco MDS 48-Port 10-Gbps Ethernet Module also provide the following advanced FCoE features:

- Inter-VSAN Routing (IVR)
- Nondisruptive software upgrade
- Port channels (up to 16 links)
- SAN trunking
- SNMP traps for alerts
- Virtual SANs (VSANs)

The following figure shows a Cisco MDS 48-Port 10-Gigabit Fiber Channel over Ethernet module. The front panel connectors support standard modular SFP+ transceivers.

**Figure 18: Cisco MDS 48-Port 10-Gbps Fiber Channel over Ethernet Module**

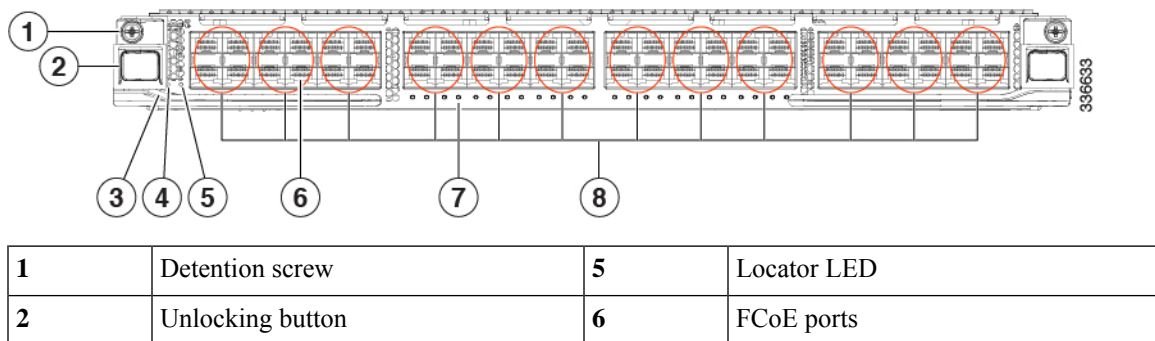

3	Ejector Lever	7	Link LEDs
4	Status LED	8	FCoE port group. Each port group consists of 4 ports.

The following table describes the LEDs for the 48-Port 10-Gbps Fiber Channel over Ethernet Module.

**Table 13: Cisco MDS 9700 Series 48-Port 10-Gbps FCoE Module LEDs**

LED	Status	Description
Status	Green	All diagnostics pass. The module is operational (normal initialization sequence).
	Orange	One of the following occurs or occurred: <ul style="list-style-type: none"> <li>The module is booting or running diagnostics (normal initialization sequence).</li> <li>The inlet air temperature of the system has exceeded the maximum system operating temperature limit (a minor environmental warning). To ensure maximum product life, you should immediately correct the environmental temperature and restore the system to normal operation.</li> </ul>
	Red	One of the following occurs: <ul style="list-style-type: none"> <li>The diagnostic test failed. The module is not operational because a fault occurred during the initialization sequence.</li> <li>The inlet air temperature of the system has exceeded the safe operating temperature limits of the card (a major environmental warning). The card has been shut down to prevent permanent damage.</li> </ul>
ID	Blinking blue	The operator has activated this LED to identify this module in the chassis.
	Off	This module is not being identified.
Link	Solid green	Link is up.
	Intermittent blinking green	Link is up (traffic on port).
	Solid orange	SFP is not present or Admin is down.
	Blinking orange	A fault condition exists.
	Off	The port is not active or the link is not connected.

## Fan Modules or Trays

This section describes the fan modules or trays present in the Cisco MDS 9700 Series Directors.

If a fan module or tray fails, it does not affect the thermal performance of the system. The redundant fan controllers and other internal mechanisms ensure that the switch, and fan modules are operational.

If a single fan module or tray fails, the system continues to operate under all conditions. Two fan failures might cause alarms from ASIC when the temperature exceeds the threshold. At 86°F (30°C) or less, a single fan module or tray can be removed and the system can continue to operate up to 72 hours to allow for replacement of a failed fan module or tray. When the temperature exceeds the threshold, the device automatically shuts down in 3 minutes.

## Cisco MDS 9718 Director Fan Modules

The Cisco MDS 9718 Director has three fan modules, each with six fans, that are installed vertically at the back of the chassis. Each fan module can be removed while the other two fan modules continue to move air through the chassis.

The fan modules cover the crossbar fabric switching modules in the back of the chassis. Fan module 1 must be removed to access the crossbar fabric switching modules 1 and 2, fan module 2 must be removed to access the crossbar fabric switching modules 3 and 4, and the fan module 3 must be removed to access the crossbar fabric switching modules 5 and 6.

Figure 19: MDS 9718 Fan Modules External and Internal View

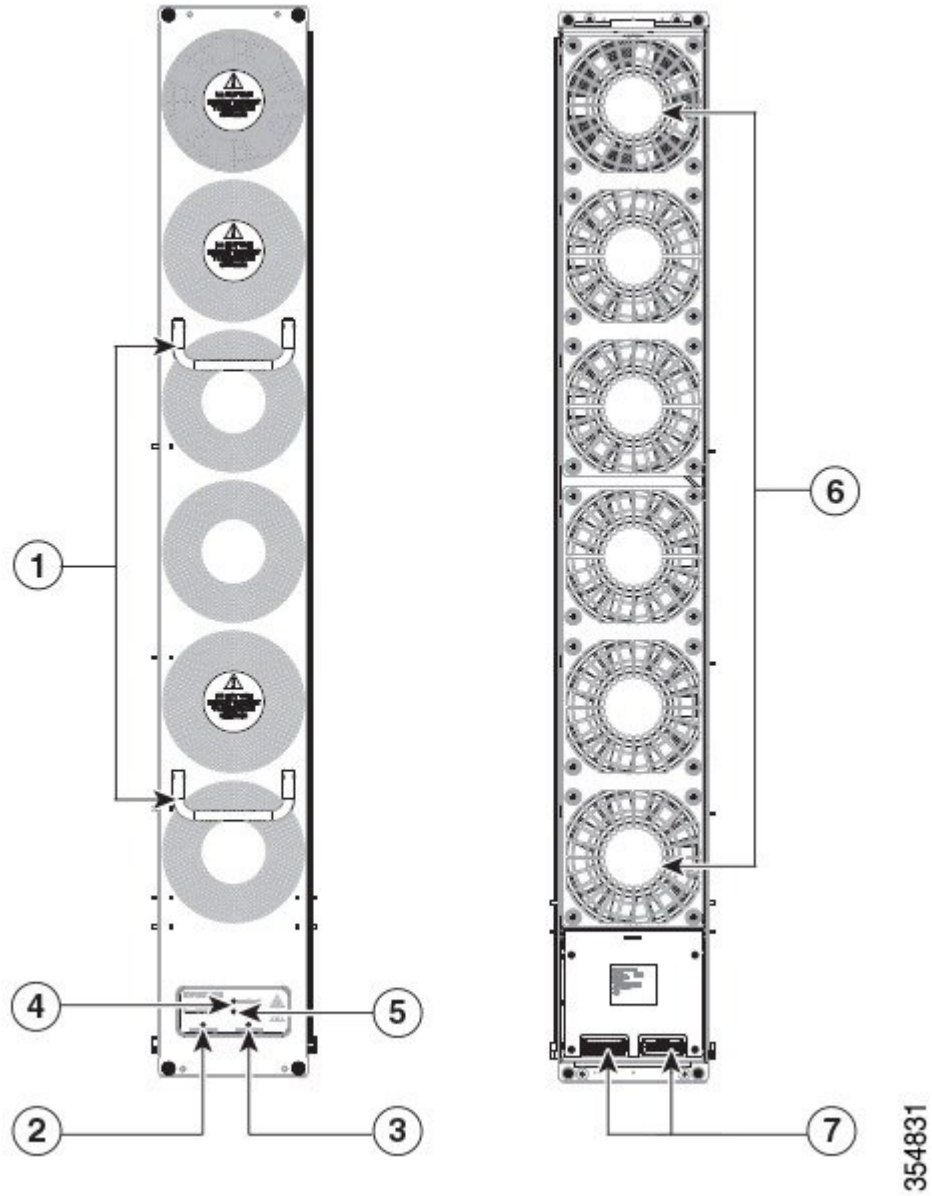

1	Fan handles	5	Right crossbar fabric switching module status LED
2	Fan module status LED	6	Fans (6)
3	Fan module locator LED	7	Fan module connectors

4	Left crossbar fabric switching module status LED		
---	--	--	--

## Cisco MDS 9710 Director Fan Modules

The Cisco MDS 9710 Director has three fan modules, each with four fans, that are installed vertically at the back of the chassis. Each fan module can be removed while the other two fan modules continue to move air through the chassis.

The fan modules cover the crossbar fabric switching modules in the back of the chassis. Fan module 1 must be removed to access the crossbar fabric switching modules 1 and 2, the fan module 2 must be removed to access the crossbar fabric switching modules 3 and 4, and the fan module 3 must be removed to access the crossbar fabric switching modules 5 and 6.

**Figure 20: MDS 9710 Fan Modules External and Internal View**

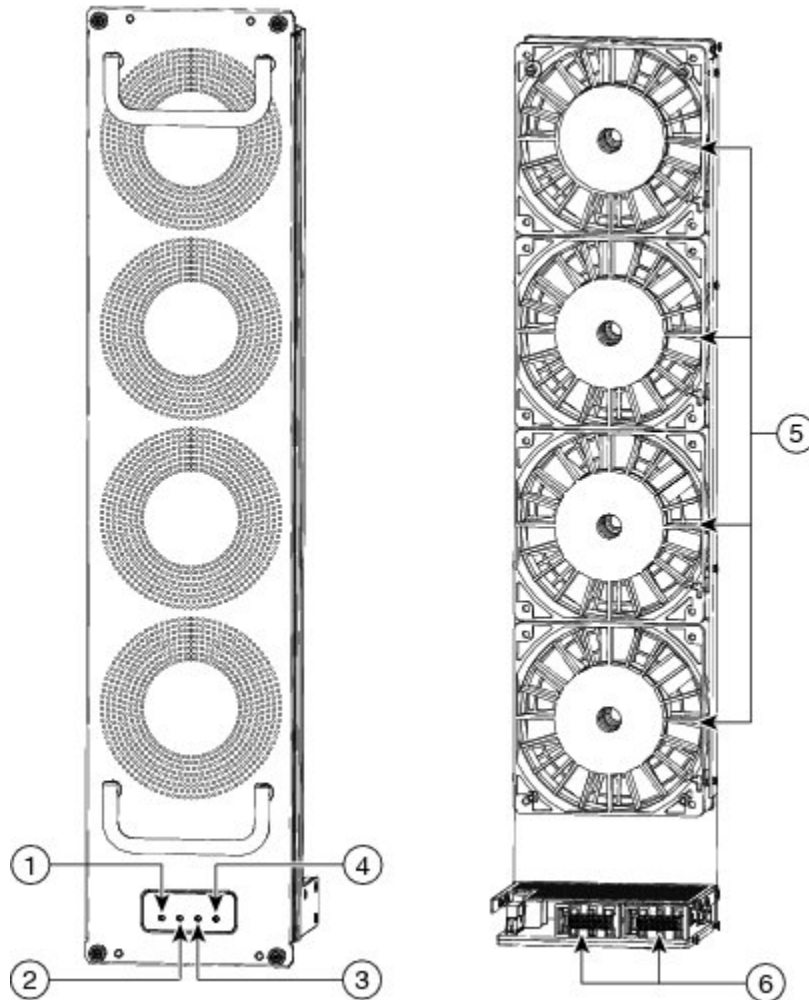

1	Left crossbar fabric switching module status LED	4	Right crossbar fabric switching module status LED
2	Fan module status LED	5	Fans (4)

3	Fan module locator LED	6	Fan module connectors
---	------------------------	---	-----------------------

## Cisco MDS 9706 Director Fan Modules

The Cisco MDS 9706 Director has three fan modules, each with two fans, that are installed vertically at the back of the chassis. Each fan module can be removed while the other two fan modules continue to move air through the chassis.

The fan modules cover the crossbar fabric switching modules in the back of the chassis. Fan module 1 must be removed to access the crossbar fabric switching modules 1 and 2, the fan module 2 must be removed to access the crossbar fabric switching modules 3 and 4, and the fan module 3 must be removed to access the crossbar fabric switching modules 5 and 6.

Figure 21: Cisco MDS 9706 Fan Modules External and Internal View

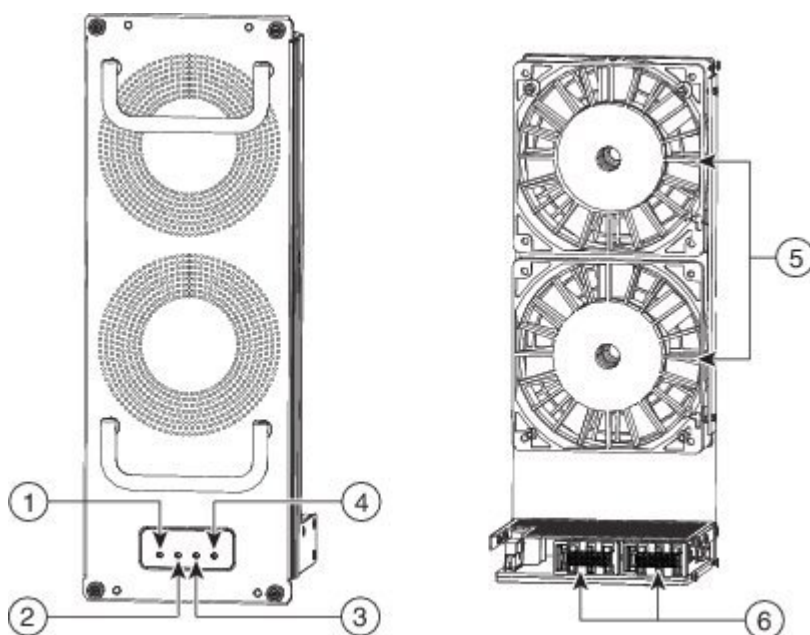

1	Left crossbar fabric switching module status LED	4	Right crossbar fabric switching module status LED
2	Fan module status LED	5	Fans (4)
3	Fan module locator LED	6	Fan module connectors

## Power Supplies

The Cisco MDS 9700 Series supports the following types of power supplies:

- 3000-W AC power supply (AC input and DC output) (DS-CAC97-3KW)
- 3000-W DC power supply (DC input and DC output) (DS-CDC97-3KW)
- 3.5-kW HVAC/HVDC power supply (AC/DC input and DC output) (DS-CHV-3.5KW)

The Cisco MDS 9718 Director supports up to 16 hot-swappable 3000-W AC or DC power supplies.

The Cisco MDS 9710 Director supports up to eight hot-swappable 3000-W AC or DC power supplies.

The Cisco MDS 9706 Director supports up to four hot-swappable 3000-W AC or DC power supplies.

The 3000-W AC power supply unit may be connected to either 220 V or 110 V AC power sources. When connected to 220 V each PSU has a maximum output capacity of 3000 W. When connected to 110 V each PSU has a maximum output capacity of 1450 W.

Each power supply module monitors its output voltage and provides the status to the supervisor module. In addition, the power supply modules provide information about local fans, power, shutdown control, and E2PROM to the supervisor.



**Note** The minimum number of AC PSUs required to achieve grid redundancy on each of the Cisco MDS 9700 Series Directors differ. For more information, see the *AC Power Supply Requirements for Grid Redundancy* section. For more information on power supply specifications, see the *Power Supply Specifications* section under the *Technical Specifications* chapter.

When PSUs are in 1450-W mode and the system is configured in redundant power mode, the total power available to the system may not be sufficient to power all modules installed in the chassis. For more information, refer to the *Cisco MDS 9000 Family NX-OS Fundamentals Configuration Guide*.

Starting from Cisco MDS NX-OS Release 6.2(19), all Cisco MDS NX-OS 6.2(x) releases support a 3500-W high-voltage DC (HVDC) power supply unit (DS-CHV-3.5KW) on Cisco MDS 9706 and MDS 9710 Directors.

Starting from Cisco MDS NX-OS Release 8.3(1), a 3500-W high-voltage DC (HVDC) power supply unit (DS-CHV-3.5KW) is supported on Cisco MDS 9718 Directors.

Starting from Cisco MDS NX-OS Release 8.1(1b), a 3500-W high-voltage DC (HVDC) power supply unit (DS-CHV-3.5KW) is supported on Cisco MDS 9700 Series switches.

**Figure 22: 3000-W AC Power Supply**

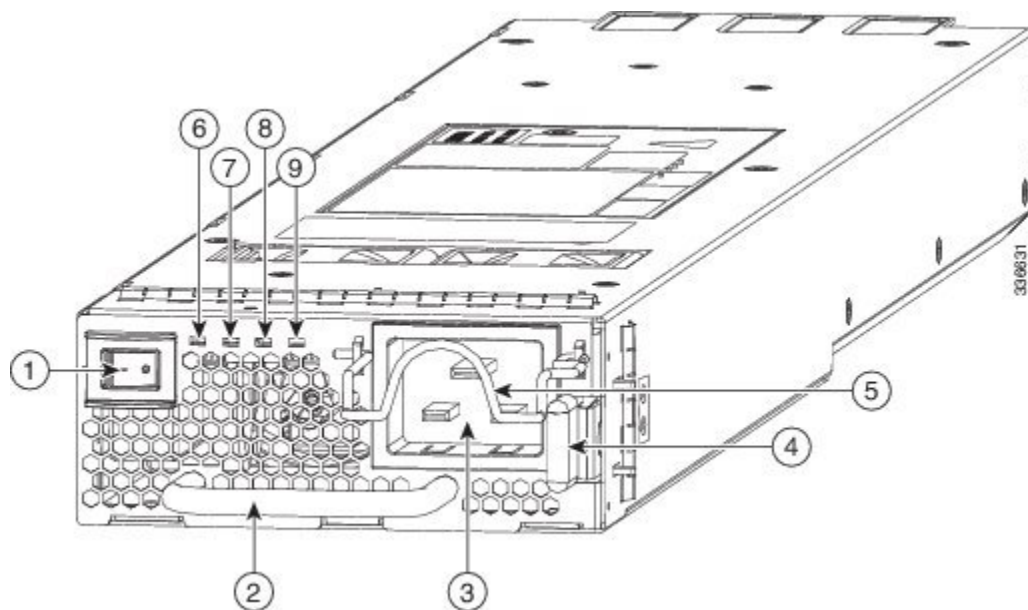

1	Power supply switch
2	Power module handle
3	AC power connection
4	Ejector lever
5	Power cable retainer
6	Input power module LED
7	Output power module LED
8	Fault power module LED
9	ID power module LED

Figure 23: 3000-W DC Power Supply

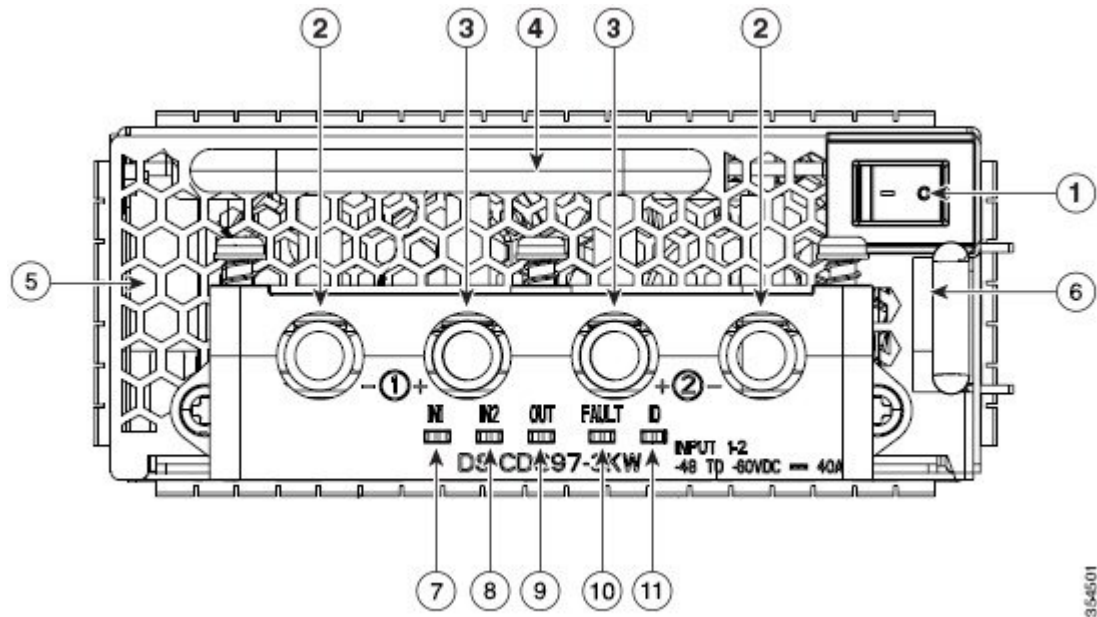

1	Power supply switch
2	Negative terminals
3	Positive terminals
4	Power supply handle
5	Power supply exhaust
6	Ejector lever
7	Power module LED – Input1 power module LED
8	Power module LED – Input2 power module LED
9	Power module LED – Output power module LED
10	Fault power module LED



11	ID power module LED
----	---------------------

The following table describes the power supply LEDs for the Cisco MDS 9700 Series.

**Table 14: Cisco MDS 9700 Series Power Supply LEDs**

LED	Status	Description
Input 1	Green	The AC or DC input voltage is within the valid range.
	Off	The AC or DC input voltage is outside the valid range.
Input 2 (available only on DC power supply units)	Green	The DC input voltage is within the valid range.
	Off	The DC input voltage is outside the valid range.
Output	Green	The AC or DC output power is within the valid range.
	Off	The AC or DC output power is outside the valid range.
Fault	Red, blinking (The blinking stops when the fault condition is cleared.)	Self-diagnostic tests have failed or another power supply failure has occurred.
	Off	The AC or DC output voltage and power supply unit tests are okay.
ID	Blue, blinking	The operator has activated this LED to identify this module in the chassis.
	Off	This module is not being identified.

## Supported Transceivers

The Cisco MDS 9710 Director supports the Fiber Channel SFP+ transceivers in Shortwave (SW), Longwave (LW), Long Distance (CWDM and DWDM), or Extended Long Wavelength (ELW).

### Fiber Channel SFP+ Transceivers

The transceivers are field-replaceable and hot-swappable. You can use any combination of SFP+ transceivers that are supported by the switch. The only restrictions are that SW transceivers must be paired with SW transceivers, and LW transceivers with LW transceivers, and the cable must not exceed the stipulated cable length for reliable communications.

For more information about a specific Cisco SFP+ transceiver, see the *SFP+ Transceiver Specifications* section. SFP+ transceivers can be ordered separately or with the Cisco MDS 9700 Series.



**Note** Use only Cisco transceivers or Cisco qualified transceivers in the Cisco MDS 9700 Series. Each Cisco transceiver is encoded with model information that enables the switch to verify that the transceiver meets the requirements for the switch.





## CHAPTER 3

# Preparing the Site

---

This chapter includes the following sections:

- [Humidity Requirements, on page 61](#)
- [Altitude Requirements, on page 61](#)
- [Dust and Particulate Requirements, on page 62](#)
- [Minimizing Electromagnetic and Radio Frequency Interference, on page 62](#)
- [Shock and Vibration Requirements, on page 63](#)
- [Grounding Requirements, on page 63](#)
- [Planning for Power Requirements, on page 63](#)
- [Power Modes Overview, on page 64](#)
- [Rack and Cabinet Requirements, on page 66](#)
- [Clearance Requirements for Cisco MDS 9700 Series Directors, on page 68](#)
- [Rack-Mounting Guidelines, on page 70](#)
- [Installing and Removing the Brackets, on page 71](#)
- [Installing the Cisco MDS 9700 Series Shelf Bracket Kit into a Rack, on page 71](#)
- [Installing the Switch on the Brackets, on page 72](#)
- [Removing the Shelf Bracket Kit, on page 74](#)

## Humidity Requirements

High humidity can cause moisture to seep into the switch. Moisture can cause corrosion of internal components and degradation of properties such as electrical resistance, thermal conductivity, physical strength, and size. The switch is rated to operate at 8 to 80 percent relative humidity, with a humidity gradation of 10 percent per hour.

The switch can withstand from 5 to 90 percent relative humidity. Buildings in which the climate is controlled by air-conditioning in the warmer months and by heat during the colder months usually maintain an acceptable level of humidity for the switch equipment. However, if the switch is located in an unusually humid location, you should use a dehumidifier to maintain the humidity within an acceptable range.

## Altitude Requirements

If you operate a switch at a high altitude (low pressure), the efficiency of forced and convection cooling is reduced and can result in electrical problems that are related to arcing and corona effects. This condition can

also cause sealed components with internal pressure, such as electrolytic capacitors, to fail or to perform at a reduced efficiency. This switch is rated to operate at altitudes from –500 to 13,123 feet (–152 to 4,000 meters). You can store the switch at altitudes of –1,000 to 30,000 feet (–305 to 9,144 meters).

## Dust and Particulate Requirements

Exhaust fans cool power supplies and system fan modules cool switches by drawing in air and exhausting air out through various openings in the chassis. However, fans also ingest dust and other particles, causing contaminant buildup in the switch and increased internal chassis temperature. A clean operating environment can greatly reduce the negative effects of dust and other particles, which act as insulators and interfere with the mechanical components in the switch.



---

**Note** If you are using this switch in a non-clean environment, you can order and install optional air filters. These air filters require that you also order the optional front door for the chassis.

---

In addition to regular cleaning, follow these precautions to avoid contamination of your switch:

- Do not permit smoking near the switch.
- Do not permit food or drink near the switch.

## Minimizing Electromagnetic and Radio Frequency Interference

Electromagnetic interference (EMI) and radio frequency interference (RFI) from the switch can adversely affect other devices such as radio and television (TV) receivers operating near the switch. Radio frequencies that emanate from the switch can also interfere with cordless and low-power telephones. Conversely, RFI from high-power telephones can cause spurious characters to appear on the switch monitor.

RFI is defined as any EMI with a frequency above 10 kHz. This type of interference can travel from the switch to other devices through the power cable and power source or through the air like transmitted radio waves. The Federal Communications Commission (FCC) publishes specific regulations to limit the amount of EMI and RFI that can be emitted by computing equipment. Each switch meets these FCC regulations.

To reduce the possibility of EMI and RFI, follow these guidelines:

- Cover all open expansion slots with a metal filler.
- Always use shielded cables with metal connector shells for attaching peripherals to the switch.

When wires are run for any significant distance in an electromagnetic field, interference can occur between the field and the signals on the wires and cause the following implications:

- Bad wiring can result in radio interference emanating from the plant wiring.
- Strong EMI, especially when it is caused by lightning or radio transmitters, can destroy the signal drivers and receivers in the chassis and even create an electrical hazard by conducting power surges through lines into equipment.



---

**Note** To predict and prevent strong EMI, you might need to consult experts in radio frequency interference (RFI). The wiring is unlikely to emit radio interference if you use twisted-pair cable with a good distribution of grounding conductors. If you exceed the recommended distances, use a high-quality twisted-pair cable with one ground conductor for each data signal when applicable.

If the wires exceed the recommended distances, or if wires pass between buildings, give special consideration to the effect of a lightning strike in your vicinity. The electromagnetic pulse caused by lightning or other high-energy phenomena can easily couple enough energy into unshielded conductors to destroy electronic switches. You may want to consult experts in electrical surge suppression and shielding if you had similar problems in the past.

---

## Shock and Vibration Requirements

The switch is being shock- and vibration-tested for operating ranges, handling, and earthquake standards to Network Equipment Building Standards (NEBS) Zone 4 per GR-63-Core.

## Grounding Requirements

The switch is sensitive to variations in voltage supplied by the power sources. Overvoltage, undervoltage, and transients (or spikes) can erase data from the memory or cause components to fail. To protect against these types of problems, ensure that there is an earth-ground connection for the switch. You can connect the grounding pad on the switch either directly to the earth-ground connection or to a fully bonded and grounded rack.

You must provide the grounding cable to make this connection but you can connect the grounding wire to the switch using a grounding lug that ships with the switch. Size the grounding wire to meet local and national installation requirements. Depending on the power supply and system, a 12 AWG to 6 AWG copper conductor is required for U.S. installations (for those installations, we recommend that you use commercially available 6 AWG wire). The length of the grounding wire depends on the proximity of the switch to proper grounding facilities.



---

**Note** You automatically ground the AC power supplies when you connect them to a power source, but you cannot ground a 3-kW DC power supply. You must connect the chassis to the facility earth ground.

---

## Planning for Power Requirements

To plan for the power requirements of a switch, you must determine each of the following:

Power requirements of the switch

Minimum number of power supplies required to power the switch and its components

Power mode to use and the number of additional power supplies required for that mode

You must also ensure that the circuit used for the switch is dedicated to the switch to minimize the possibility of circuit failure.

When you know the amount of power that is required for operations (available power) and redundancy (reserve power), you can plan for the required number of input power receptacles with reach of the switch location.

## Power Modes Overview

You can configure one of the following power modes to either use the combined power provided by the installed power supply units (no power redundancy) or to provide power redundancy when there is a power loss:

### Combined Mode

This mode allocates the combined power of all power supplies to active power for switch operations. This mode does not allocate reserve power for power redundancy in case of power outages or power supply failures.

### Power supply redundancy mode (N+1)

This mode allocates one power supply as a reserve power supply in case an available power supply fails. The remaining power supplies are allocated for available power. The reserve power supply must be at least as powerful as the most powerful power supply in the available pool to potentially replace the full power output of the failed power supply in the worst case. Because it is impossible to predict which power supply may fail, we recommend provisioning the system with power supplies of equal rating. This way the output of any power supply that fails can be replaced by the remaining power supplies.

For example, a system with four 3-kW power supplies in N+1 redundancy mode has a total of 12-kW. 9-kW are allocated to the available power pool and 3-kW are reserved. If any of the power supplies fail enough power is reserved that the remaining power supplies can still meet the 9-kW commitment.

### Input grid redundancy mode (grid redundancy)

In this mode half of the power supply's output is allocated to the reserve power pool and half to the available power pool. This provides the system with enough reserve power in the case of 50% of the power supplies failing, as when a power grid fails. The system logically allocates the left two columns of PSU bays to Grid A and sums the output power of operational PSUs. It does the same for the right two columns (Grid B) and uses the minimum of the two as the available power pool. To utilize maximum power the sum of power supply outputs of Grid A and Grid B PSU bays must be equal.

For example, a system with four 3-kW PSUs in Grid A bays and three 3-kW PSUs in Grid B bays and in grid redundancy mode has 12-kW available from Grid A and 9-kW from Grid B. The minimum of the two grids is 9-kW so 9-kW is allocated to the available power pool and 9-kW are reserved. If either grid fails enough power is reserved that the remaining power supplies can still meet the 9-kW commitment. The output of the fourth PSU in Grid A is not considered in the calculations although it provides power.

### Full redundancy mode

This mode supports both grid redundancy or N+1 redundancy. 50% of the power supply output is allocated to the reserve pool and the other 50% of the power supply outputs are allocated to the available power pool. The reserved power may be used to backup either single power supply failures or a grid failure.

For example, a system with six 3-kW power supplies in grid redundancy mode has a total of 18-kW. 9-kW are allocated to the available power pool and 9-kW are allocated to the reserve pool. If a grid failure occurs

(half of the power supplies lose power) the full reserve power pool is available to meet the 9-kW commitment. Otherwise, as single power supplies fail power is allocated to the available pool from the remaining reserve power pool until the reserve power pool is exhausted.



**Note** Once a single power supply has failed in this mode, grid redundancy is no longer available.

The following figure shows how to connect power supplies in a Cisco MDS 9718 for grid redundancy.

**Figure 24: Cisco MDS 9718 Grid-PSU Connections**

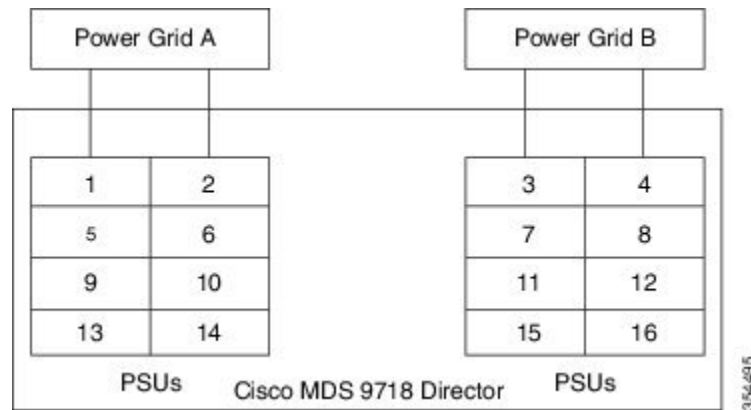

The following figure shows how to connect power supplies in a Cisco MDS 9710 for grid redundancy.

**Figure 25: Cisco MDS 9710 Grid-PSU Connections**

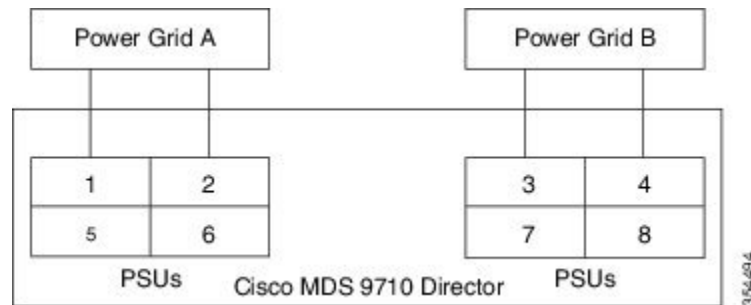

The following figure shows how to connect power supplies in a Cisco MDS 9706 for grid redundancy.

**Figure 26: Cisco MDS 9706 Grid-PSU Connections**

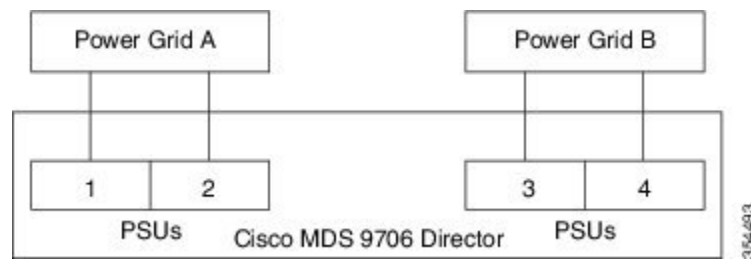

# Rack and Cabinet Requirements

This section provides the requirements for the following type of racks, assuming an external ambient air temperature range of 32°F to 104°F (0 to 40°C):

## General Requirements for Open Four-Post Racks

The rack must be a standard 19-inch four-post EIA rack, with mounting rails that conform to English universal hole spacing per section 1 of ANSI/EIA-310-D-1992. See the [Clearance Requirements for Cisco MDS 9700 Series Directors, on page 68](#) section.

## General Rack and Cabinet Requirements for Cisco MDS 9700 Series Directors

You can install the following types of racks or cabinets for your switch:

- Standard perforated-doors cabinets
- Solid-walled cabinets with a roof fan module (bottom to top cooling)
- Standard open four-post Telco racks
- Standard open two post Telco racks



---

**Note** Cisco MDS 9700 Series Directors are compatible with Cisco racks (such as Cisco R42612) and PDUs.

---

Use a standard 19 inch, four post Electronic Industries Alliance (EIA) cabinet or rack with mounting rails that conform to English universal hole spacing per section 1 of the ANSI/EIA-310-D-1992 standard.

The depth of a four post rack or a cabinet must be 24 to 32 inches (61.0 to 81.3 cm) between the front and rear mounting vertical rails.

Ensure that the airflow and cooling are adequate and there is sufficient clearance around the air vents on the switch, as described in

The rack must have sufficient vertical clearance for the chassis and any desired clearance for the installation process. The shelf brackets are 2 RU, and they are built and installed so that they do not add up to the total chassis vertical clearance of 14 RU.

The front and rear doors of enclosed racks must have at least 60% open area perforation pattern.

Additionally, you must consider the following site requirements for the rack:

- Power receptacles must be located within reach of the power cords used with the switch.
  - AC power supplies
- Power cords for 3-kW AC power supplies are 8 to 12 feet (2.5 to 4.3 m) long.
  - DC power supplies
- Power cords for 3.0-kW DC power supplies are supplied and dimensioned by the customer.
  - HVAC/HVDC power supplies



- Power cords for 3.5-kW HVAC/HVDC power supplies are 14 feet (4.26 m) long.
- Where necessary, have a seismic rating of Network Equipment Building Standards (NEBS) Zone 3 or Zone 4, per GR-63-CORE.

## Rack and Cabinet Requirements for the Cisco MDS 9718 Chassis

To correctly install the switch in a cabinet that is located in a hot-aisle/cold-aisle environment, you should fit the cabinet with baffles to prevent exhaust air from recirculating into the chassis air intake. Work with your cabinet vendors to determine which of their cabinets meet the following requirements or see the Cisco Technical Assistance Center (TAC) for recommendations:

- The height of the rack or cabinet must accommodate the 25 RU (43.75 inches or 111.1 cm) height of the switch and its bottom support bracket.
- Minimum gross load rating of 2000 lb (907.2 kg) (static load rating) if supporting two switches.

## Rack and Cabinet Requirements for the Cisco MDS 9710 Chassis

The rack must meet the following requirements:

- The minimum vertical rack space per chassis is 24.5 inches (62.2 cm) or 14 RU.
- The width between the mounting rails must be at least 17.75 inches (45.1 cm). For four-post EIA racks, this is the distance between the two front rails and rear rails.

To correctly install the switch in a cabinet that is located in a hot-aisle/cold-aisle environment, you should fit the cabinet with baffles to prevent exhaust air from recirculating into the chassis air intake. Work with your cabinet vendors to determine which of their cabinets meet the following requirements or see the Cisco Technical Assistance Center (TAC) for recommendations:

- The height of the rack or cabinet must accommodate the 14-RU (24.5 inches or 62.2 cm) height of the switch and its bottom support bracket.
- Minimum gross load rating of 2000 lb (907.2 kg) (static load rating) if supporting three switches.

## Rack and Cabinet Requirements for the Cisco MDS 9706 Chassis

To correctly install the switch in a cabinet that is located in a hot-aisle/cold-aisle environment, you should fit the cabinet with baffles to prevent exhaust air from recirculating into the chassis air intake. Work with your cabinet vendors to determine which of their cabinets meet the following requirements or see the Cisco Technical Assistance Center (TAC) for recommendations:

- The height of the rack or cabinet must accommodate the 9 RU (15.75 inches or 40.0 cm) height of the switch and its bottom support bracket. The bottom support bracket ships as a part of the accessory kit for the switch.
- Minimum gross load rating of 2000 lb (907.2 kg) (static load rating) if supporting four switches.

# Clearance Requirements for Cisco MDS 9700 Series Directors

You must provide adequate clearance between the chassis and any other rack, device, or structure so that you can properly install the chassis, route cables, provide airflow, and maintain the switch. Ensure that the following clearance requirements are met:

- 7 inches (17.78 cm) between the front of chassis and inside of cabinet.
- 34 inches (86.36 cm) [40 inches recommended (101 cm)] in front of the cabinet so that a fully loaded 34 inches (86.36 cm) chassis box can be moved.
- 2 inches (5.08 cm) for module handles.
- 3 inches (7.62 cm) between the rear of the chassis and the inside of the cabinet, that is, the perforated rear door (required for airflow in the cabinet if used).
- 25 inches (63.5 cm) outside of the cabinet to remove fabric modules.
- No clearance is required between the chassis and the sides of the rack or cabinet (no side airflow).
- Clearance required for cables that connect to as many as 400 ports (in addition to the cabling required for other devices in the same rack). These cables must not block access to any removable chassis modules or block airflow into or out of the chassis. Route the cables through the cable management frames on the left and right sides of the chassis.

The following figure illustrates the front, rear, and side clearance requirements for Cisco MDS 9700 Series Directors.

Figure 27: Clearance Requirements for Cisco MDS 9700 Series Directors (Top View)

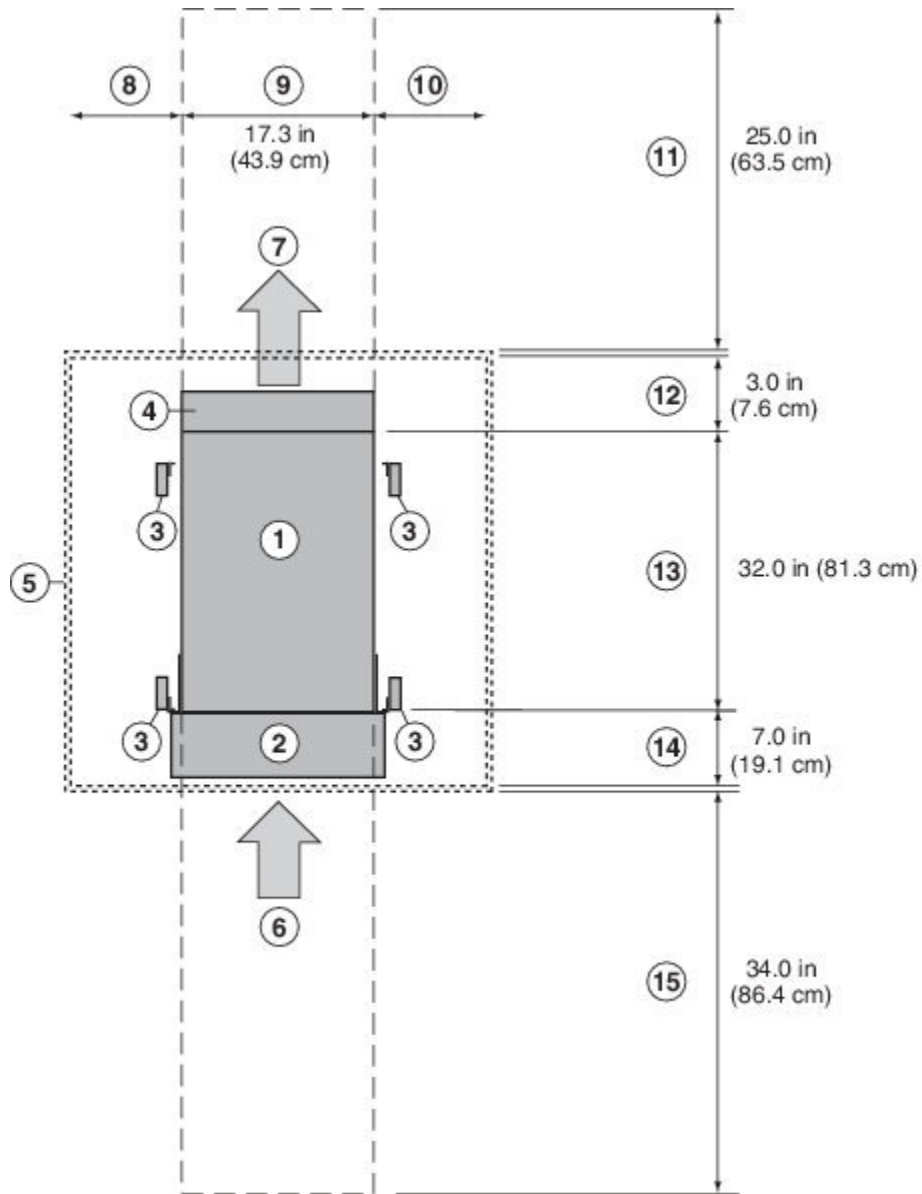

355403

Table 15: Cisco MDS 9700 Clearance Requirements

1	Chassis
2	Cable Management Frames
3	Vertical rack-mount posts and rails
4	Area used for fan tray handles at the rear of the chassis (allow 2 inches [5 cm])
5	Nearest object or inside of cabinet (no side clearance required)

6	Fibre Channel ports. Air intake from the cold aisle for all modules and power supplies
7	Air exhaust to the hot aisle for all modules and power supplies
8	No left side clearance required (no airflow on left side)
9	Chassis width
10	No right side clearance required (no airflow on right side)
11	Rear service clearance required to replace fan trays and fabric modules
12	Airflow clearance area required at the rear of the chassis within the cabinet (if a cabinet is used)
13	Chassis depth
14	Clearance required between the front of the chassis and the inside of the cabinet (if used) or the edge of the cold aisle (if no cabinet) for the cable management frames and the optional front doors
15	Front service clearance required for installing the chassis and replacing the modules on the front of the chassis

## Rack-Mounting Guidelines



### Caution

If the rack is on wheels, ensure that the brakes are engaged or the rack is otherwise stabilized.

If installing this kit in an EIA rack, attach the switch to all four rack-mounting rails; the EIA rails may not be thick enough to prevent flexing of the shelf brackets if only two rails are used.

## Before Installing the Rack-Mount Support Brackets

Before installing the rack-mount support brackets for the Cisco MDS 9700 Series, check the contents of your kit. The table below, lists the contents of the shelf bracket kit.

**Table 16: Contents of Rack-Mount Support Brackets Kit**

Quantity	Part Description
2	Bottom support brackets
20	12-24 x 3/4-in. Phillips screws
20	M6 x 19 mm Phillips binder-head screws
20	10-32 x 3/4-inch screws

## Installing and Removing the Brackets

This section provides information on how to install and remove brackets.

Before installing the shelf brackets, check the contents of your kit. The table below, lists the contents of the shelf bracket kit.

**Table 17: Contents of Shelf Bracket Kit**

Quantity	Part Description
2	Slider brackets
2	Shelf brackets
1	Crossbar
2	10-32 x 3/8-in. Phillips pan-head screws
16	12-24 x 3/4-in. Phillips screws
16	10-24 x 3/4-in. Phillips screws

### Required Equipment

You need the following equipment for this installation:

- Number 2 Phillips screwdriver
- Tape measure and level (to ensure shelf brackets are level)

## Installing the Cisco MDS 9700 Series Shelf Bracket Kit into a Rack

Use this procedure to install the shelf brackets in a rack.

The following figure shows the installation of the Cisco MDS 9700 Series Shelf Bracket Kit into a four-post rack.

Figure 28: Installing the Shelf Bracket Kit into a Rack

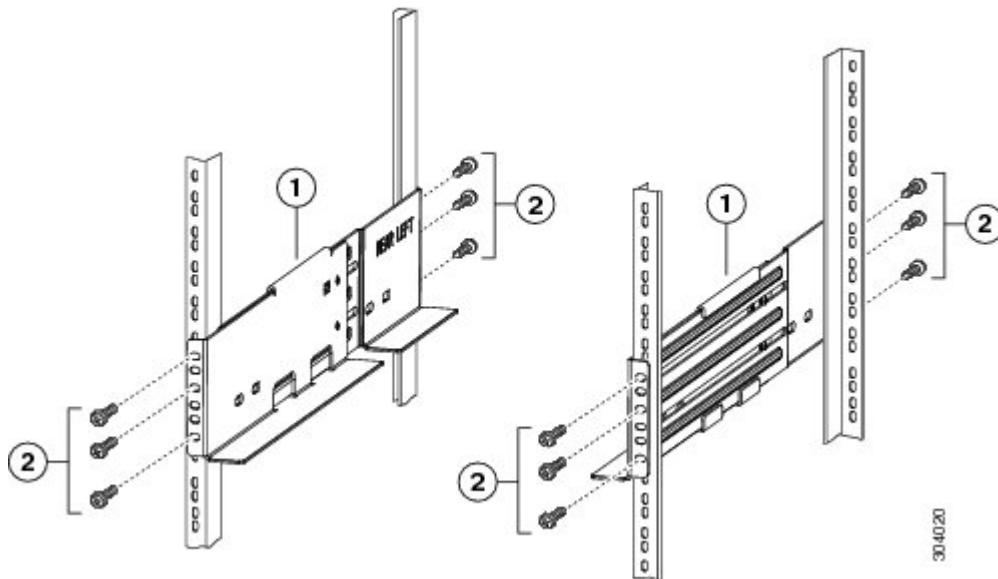

## Procedure

- 
- Step 1** Position a shelf bracket inside the rack-mounting rails. Align the screw holes at the front of the shelf bracket with the holes in the front rack-mounting rail, and then attach the shelf bracket to the front rack-mounting rail using a minimum of three (M6, 12-32 or 12-24) screws.
- Step 2** Align the screw holes at the back of the shelf bracket with the holes in the back rack-mounting rail, and then attach the shelf bracket to the back rack-mounting rail using a minimum three (M6, 12-32 or 12-24) screws.
- Step 3** Verify that the shelf brackets are at the same height (using the level or tape measure as desired).
- 

# Installing the Switch on the Brackets

This section provides information on how to install the switch on the rack-mount support brackets and on the shelf brackets and includes the following subsections:

## Installing the Switch on the Rack-Mount Support Brackets

Use this procedure to install the switch on top of the rack-mount support brackets.

### Before you begin

This section provides general instructions for installing the switch on top of the rack-mount support brackets. For detailed installation instructions, see the *Rack Mounting Guidelines* section, covered earlier in this chapter.

**Warning**

This unit is intended for installation in restricted access areas. A restricted access area can be accessed only through the use of a special tool, lock and key, or other means of security. Statement 1017

Only trained and qualified personnel should be allowed to install, replace, or service this equipment. Statement 1030

**Note**

Before you install, operate, or service the system, see the *Regulatory Compliance and Safety Information for the Cisco MDS 9000 Family* for important safety information.

**Procedure**

- Step 1** Verify that the rack-mount support brackets are level and securely attached to the rack-mounting rails, the support rack-mount support brace is securely attached to the brackets, and the rack is stabilized.
- Step 2** Slide a mechanical lift under the switch and lift the switch up onto the rack-mount support brackets, ensuring it is squarely positioned.
- Step 3** Attach the switch to the rack-mounting rails. See the

**Caution**

We recommend grounding the chassis, even if the rack is already grounded. There is a grounding pad with two threaded M4 holes on the chassis for attaching a grounding lug.

## Installing the Switch on the Shelf Brackets

This section provides general instructions for installing the switch on top of the shelf brackets. For detailed installation instructions for the shelf brackets, see the [Installing the Cisco MDS 9700 Series Shelf Bracket Kit into a Rack, on page 71](#) procedure.

**Before you begin**

The Cisco MDS 9700 Series Shelf Bracket Kit can be used to support the switch in a nonthreaded rack. This shelf bracket kit can be used as a permanent support when installing a Cisco MDS 9700 Series Director in a rack that meets the requirements listed in the [Rack and Cabinet Requirements, on page 66](#) section.

**Warning**

This unit is intended for installation in restricted access areas. A restricted access area can be accessed only through the use of a special tool, lock and key, or other means of security. Statement 1017

Only trained and qualified personnel should be allowed to install, replace, or service this equipment. Statement 1030



---

**Note** Before you install, operate, or service the system, see the *Regulatory Compliance and Safety Information for the Cisco MDS 9000 Family* for important safety information.

---

## Procedure

- 
- Step 1** Verify that the shelf brackets are level and securely attached to the rack-mounting rails, the crossbar is securely attached to the shelf brackets, and the rack is stabilized.
- Step 2** Slide the switch onto the shelf brackets, ensuring that it is squarely positioned.
- Step 3** Attach the Cisco MDS 9700 Series switch to the rack-mounting rails. Slide the clip nuts over the holes on the nonthreaded rails on the rack. These clip nuts provide the threading for the screws that will secure the chassis to the rack. Use the 12 10-32 x 1/2 inch screws provided in this shelf bracket kit to secure the chassis to the rack.

**Caution** We recommend that grounding the chassis, even if the rack is already grounded. There is a grounding pad with two threaded M4 holes on the chassis for attaching a grounding lug.

---

# Removing the Shelf Bracket Kit

Use this procedure to remove the shelf bracket kit.

The shelf bracket kit can be removed after the Cisco MDS 9700 Series switch has been installed in a two-post telco (only MDS 9706 Director) or four-post EIA rack, and the front rack-mount brackets are securely attached to the rack-mounting rails. For additional support in an EIA rack, ensure that the C brackets on the Cisco MDS 9710 Switch are attached to the rear rack-mounting rails.

## Procedure

- 
- Step 1** Remove the screws fastening the slider brackets to the rear rack-mounting rails. Then slide the slider brackets out of the shelf brackets.
- Step 2** Remove the screws fastening the crossbar to the shelf brackets and remove the crossbar.
- Step 3** Remove the screws fastening the shelf brackets to the front rack-mounting rails. Then remove the shelf brackets from the rack.
-





## CHAPTER 4

# Installing the Cisco MDS 9700 Series Switches

This chapter describes how to install the Cisco MDS 9700 Series Multilayer Director switches and its components. This chapter includes the following topics:

- [Preparing for Installation, on page 75](#)
- [Attaching Bottom-Support Rails to a Two-Post Rack, on page 79](#)
- [Attaching Bottom-Support Rails to a Four-Post Rack, on page 80](#)
- [System Grounding, on page 100](#)

## Preparing for Installation



---

**Note** Before you install, operate, or service the system, read the Regulatory Compliance and Safety Information for the Cisco MDS 9000 Family for important safety information.

---



---

**Warning** This warning symbol indicates danger. You are in a situation that could cause physical injury. Before you work on any equipment, be aware of the hazards involved with electrical circuitry and be familiar with standard practices for preventing accidents. Use the statement number provided at the end of each warning to locate its translation in the translated safety warnings that accompanied this device. Statement 1071

---

SAVE THESE INSTRUCTIONS

---



---

**Warning** This unit is intended for installation in restricted access areas. A restricted access area can be accessed only through the use of a special tool, lock and key, or other means of security. Statement 1017

---



---

**Warning** Only trained and qualified personnel should be allowed to install, replace, or service this equipment. Statement 1030

---



---

**Warning** A readily accessible two-poled disconnect device must be incorporated in the fixed wiring. Statement 1022

---

This section provides the following topics:

## Unpacking and Inspecting the Switch

Before you install a new chassis, you need to unpack and inspect it to be sure that you have all the items that you have ordered and verify that the switch was not damaged during the shipment. If anything is damaged or missing, contact your customer representative immediately.



---

**Caution** We recommend that you use a mechanical lift when the chassis is being moved or lifted. Fully loaded, Cisco MDS 9706 chassis can weigh up to 325 lb (147.5 kg), Cisco MDS 9710 chassis can weigh up to 449.5 lb (203.8 kg), and Cisco MDS 9718 chassis can weigh up to 923 lb (419 kg).

---



---

**Caution** When handling switch components, wear an ESD strap and handle modules by the carrier edges only. An ESD socket is provided on the chassis. For the ESD socket to be effective, the chassis must be grounded either through the power cable, the chassis ground, or metal-to-metal contact with a grounded rack.

---



---

**Tip** Keep the shipping container for use when moving or shipping the chassis in the future. The shipping carton can be flattened and stored with the pallet.

---



---

**Note** If you purchased this product through a Cisco reseller, contact the reseller directly for technical support. If you purchased this product directly from Cisco Systems, contact Cisco Technical Support at this URL: [http://www.cisco.com/en/US/support/tsd\\_cisco\\_worldwide\\_contacts.html](http://www.cisco.com/en/US/support/tsd_cisco_worldwide_contacts.html).

---



---

**Note** The switch is thoroughly inspected before shipment. If any damage occurred during transportation or any items are missing, contact your customer service representative immediately.

---

To inspect the shipment, follow these steps:

### Procedure

---

**Step 1** Compare the shipment to the equipment list provided by your customer service representative and ensure that you have received all items, including the following:

- 1 or 2 supervisor modules

- 1 to 4, 8, or 16 switching modules depending on the Cisco MDS 9700 Series switch
- Up to six crossbar fabric switching modules
- 3 fan modules
- 1 to 4, 8, or 16 power supplies depending on the Cisco MDS 9700 Series switch
- Grounding lug kit
- Mounting kit
- ESD wrist strap
- Cables and connectors
- Cable management frames
  - Left and right side frames
  - Top frame
  - M4 x 12 mm flat-head Phillips screws (12)
  - Front door (1)
  - M3X8 mm pan-head screws (2)
- Front door kit optional

**Step 2** Check for damage and report any discrepancies or damage to your customer service representative. Keep the following information ready:

- Invoice number of shipper (see packing slip)
- Model and serial number of the damaged unit
- Description of damage
- Effect of damage on the installation

---

## Required Equipments

You need the following items before beginning the installation:

- Number 1 and number 2 Phillips screwdrivers with torque capability
- 3/16-inch flat-blade screwdriver
- Tape measure and level
- ESD wrist strap or other grounding device
- Antistatic mat or antistatic foam
- Torque wrench and socket for the DC power supply lug nuts

- In addition to the grounding items provided in the accessory kit, you need the following items:
  - Grounding cable (6 AWG recommended), sized according to local and national installation requirements; the required length depends on the proximity of the Cisco MDS 9700 Series switch to proper grounding facilities.
  - Crimping tool large enough to accommodate girth of the DC lug
  - Wire-stripping tool

For the Cisco MDS 9700 Series, you need a mechanical lift to handle the weight of the fully-loaded chassis.

## Installation Guidelines

Follow these guidelines when installing a Cisco MDS 9700 Series chassis.

- Plan your site configuration and prepare the site before installing the chassis. We recommend that you use the site planning tasks listed in [Appendix 8, “Site Planning and Maintenance Records.”](#)
- Ensure that there is adequate space around the switch to allow for servicing the switch and for adequate air flow. Air flow requirements are listed in [Appendix 6, “Technical Specifications”](#).
- Ensure that the air-conditioning meets the heat dissipation requirements listed in [Appendix 6, “Technical Specifications.”](#)
- Ensure that the rack meets the requirements listed in [Appendix 2, “Rack Requirements.”](#)
- Ensure that the site power meets the power requirements listed in [Appendix 6, “Technical Specifications.”](#) You can use an uninterruptible power supply (UPS) to protect against power failures.



---

**Caution** Avoid UPS types that use ferroresonant technology. These UPS types can become unstable with systems such as the Cisco MDS 9000 Family, which can have substantial current draw fluctuations because of fluctuating data traffic patterns.

---

- Ensure that circuits are sized according to local and national codes. For North America:
  - The 3000-W AC power supplies require a 20-A circuit.

If you are using 200/240 VAC power sources in North America, the circuits must be protected by two-pole circuit breakers.



---

**Caution** To prevent loss of input power, ensure that the total maximum loads on the circuits supplying power are within the current ratings of the wiring and breakers.

---

- Record your installation and configuration information as you work. See [Appendix 8, “Site Planning and Maintenance Records.”](#)
- Use the following screw torques when installing the switch:
  - Captive screws: 4 in-lb
  - M3 screws: 4 in-lb

- M4 screws: 12 in-lb
- M6 screws: 20 in-lb
- 12-24 screws: 30 in-lb
- 10-20 screws: 22 in-lb

## Attaching Bottom-Support Rails to a Two-Post Rack

The bottom-support rails support the weight of the switch chassis in the rack or cabinet. To maximize the stability of the rack, you must attach these rails at the lowest possible rack unit (RU).



**Note** To prevent bodily injury when mounting or servicing this unit in a rack, you must take special precautions to ensure that the system remains stable. The following guidelines are provided to ensure your safety:

- This unit should be mounted at the bottom of the rack if it is the only unit in the rack.
- When mounting this unit in a partially filled rack, load the rack from the bottom to the top with the heaviest component at the bottom of the rack.
- If the rack is provided with stabilizing devices, install the stabilizers before mounting or servicing the unit in the rack.

### Before you begin

Before you can install the bottom support rails for the chassis, you must do the following:

- Verify that a two-post rack is installed and secured to the concrete sub floor (see “Installing a Rack or Cabinet”).
- If any other devices are stored in the rack or cabinet, verify that they are located below where you plan to install the switch. Also, verify that lighter devices in the same rack are located above where you plan to install this switch.
- Verify that the two-post bottom-support rails kit was ordered and shipped with the chassis.

Statement 1006

### Procedure

- Step 1** Position one of the two bottom-support rails at the lowest possible RU in the rack or cabinet. Be sure there is at least 9 RU of vertical space above the rails to install the chassis.
- Step 2** Use a manual Phillips torque screwdriver to attach the bottom-support rail to the rack using four M6 x 19 mm or 12-24 x 3/4 inch screws and tighten each screw to 40 in. lbs (4.5 N.m) of torque.

Figure 29: Attaching Bottom-Support Rails to a Rack

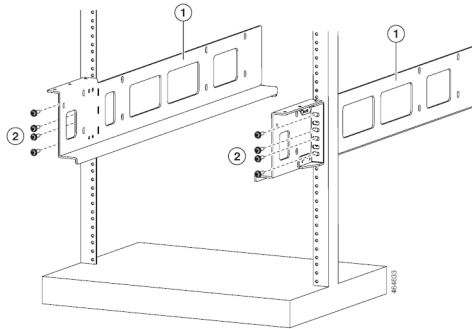

1	Adjustable bottom-support rails
2	M6 x 19 mm (or 12-24 x 3/4 in.) Phillips screws 3(6 to 8 per rail)

**Step 3** Repeat Steps 1 and 2 to attach the other bottom-support rail to the rack.

**Note** Make sure that the two bottom-support rails are level with one another. If they are not level, adjust the higher rail down to the level of the lower rail.

When the bottom-support rails are installed at the lowest possible RU and are level, you are ready to install the chassis in the rack or cabinet.

## Attaching Bottom-Support Rails to a Four-Post Rack

The bottom-support rails support the weight of the switch chassis in the rack or cabinet. To maximize the stability of the rack, you must attach these rails at the lowest possible rack unit (RU).



**Note** To prevent bodily injury when mounting or servicing this unit in a rack, you must take special precautions to ensure that the system remains stable. The following guidelines are provided to ensure your safety:

- This unit should be mounted at the bottom of the rack if it is the only unit in the rack.
- When mounting this unit in a partially filled rack, load the rack from the bottom to the top with the heaviest component at the bottom of the rack.
- If the rack is provided with stabilizing devices, install the stabilizers before mounting or servicing the unit in the rack.

Statement 1006

### Before you begin

Before you can install the bottom support rails for the chassis, you must do the following:

- Verify that a four-post rack or cabinet is installed and secured to the concrete subfloor (see “[Rack and Cabinet Requirements](#)”).
- If any other devices are stored in the rack or cabinet, verify that they are located below where you plan to install the switch. Also, verify that lighter devices in the same rack are located above where you plan to install this switch.
- Verify that the bottom-support rails kit is included in the switch accessory kit (Unpack and inspect the chassis shipment for completeness and damage).

### Procedure

---

#### Step 1

Position one of the two adjustable bottom-support rails at the lowest possible RU in the rack or cabinet and adjust the length of the rail so that it stretches from the outer edges of the front and rear vertical mounting rails. Be sure there is at least 9 RU of vertical space above the rails to install the chassis.

You can expand the rail so that its mounting brackets are spaced between 24 to 32 inches (61.0 to 81.3 cm).

Figure 30: Positioning Bottom-Support Rail - Cisco MDS 9710 Chassis

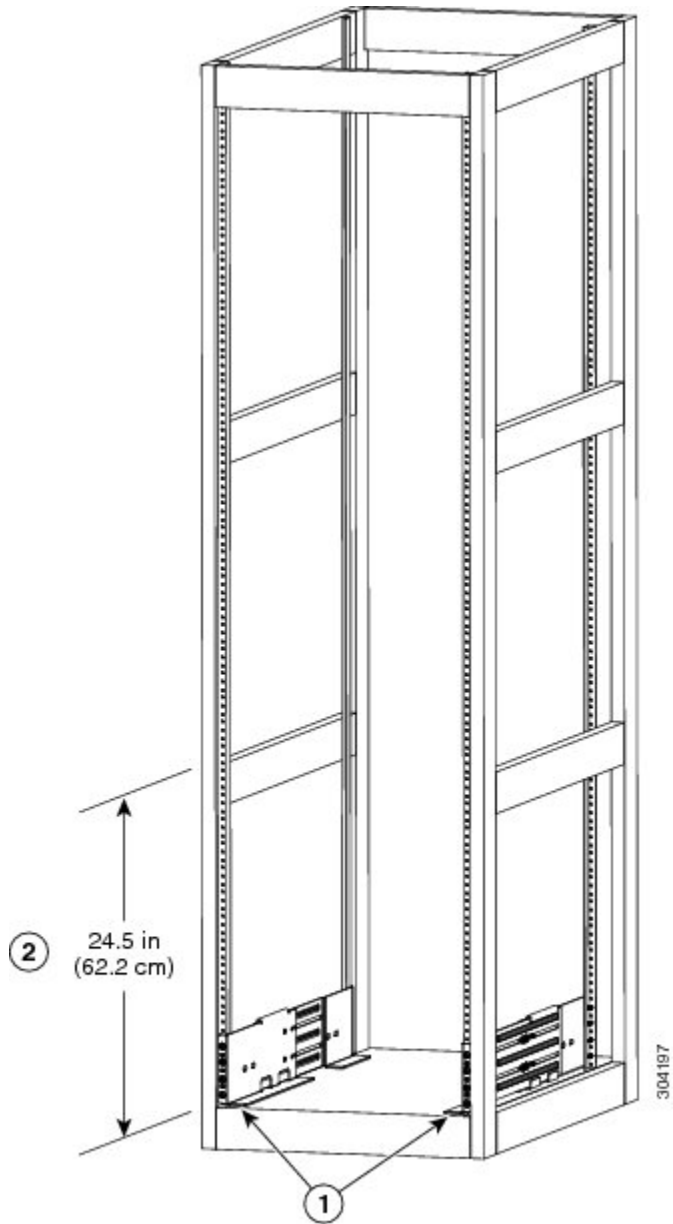

1	Position two bottom-support rails at the lowest RU on the rack.
2	Allow at least 24.5 inches (62.2 cm) (14 RU) for each chassis.



Figure 31: Positioning Bottom-Support Rail - Cisco MDS 9718 Chassis

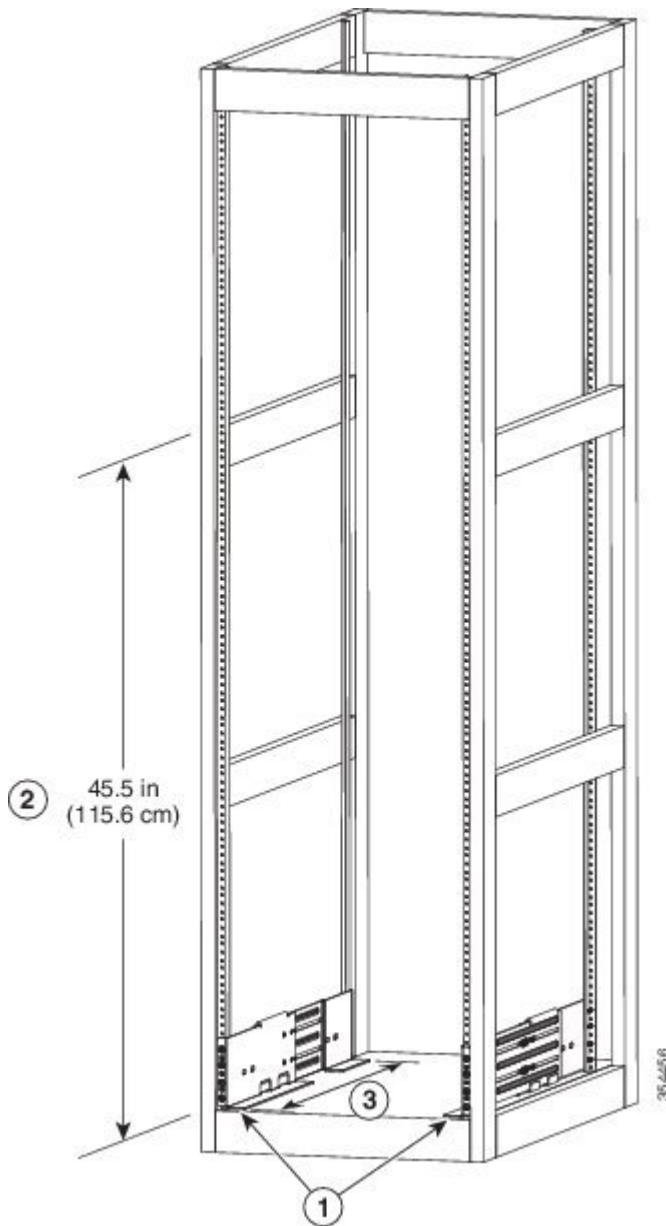

1	Position two bottom-support rails at the lowest RU on the rack.
2	Allow at least 45.5 inches (115.6 cm) (26 RU) for each chassis.

**Step 2**

Use a manual Phillips torque screwdriver to attach the bottom-support rail to the rack using at least three or four M6 x 19 mm or 12-24 x 3/4 inch screws for each end of the rail (using a total of 6 to 8 screws for the rail as shown [Figure 3-4](#)) and tighten each screw to 40 in. lbs (4.5 N.m) of torque.

Figure 32: Attaching Bottom-Support Rails to a Rack - Cisco MDS 9710 Chassis

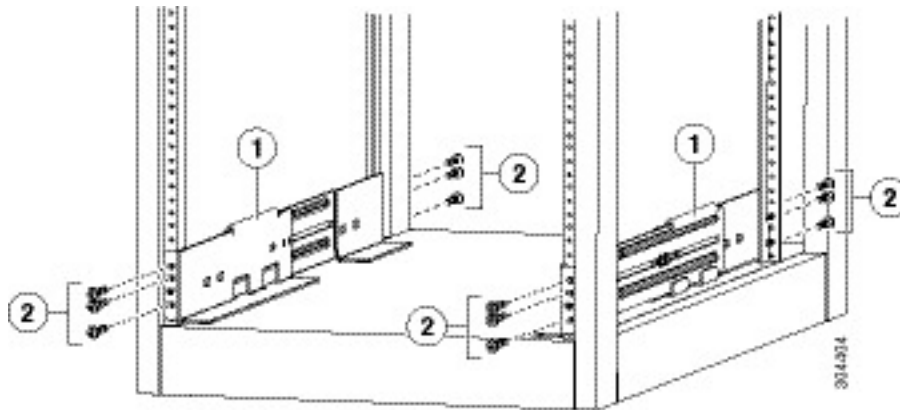

1	Adjustable bottom-support rails (2)
2	M6 x 19 mm (or 12-24 x 3/4 in.) Phillips screws (6 to 8 per rail).

Figure 33: Attaching Bottom-Support Rails to a Rack - Cisco MDS 9718 Chassis

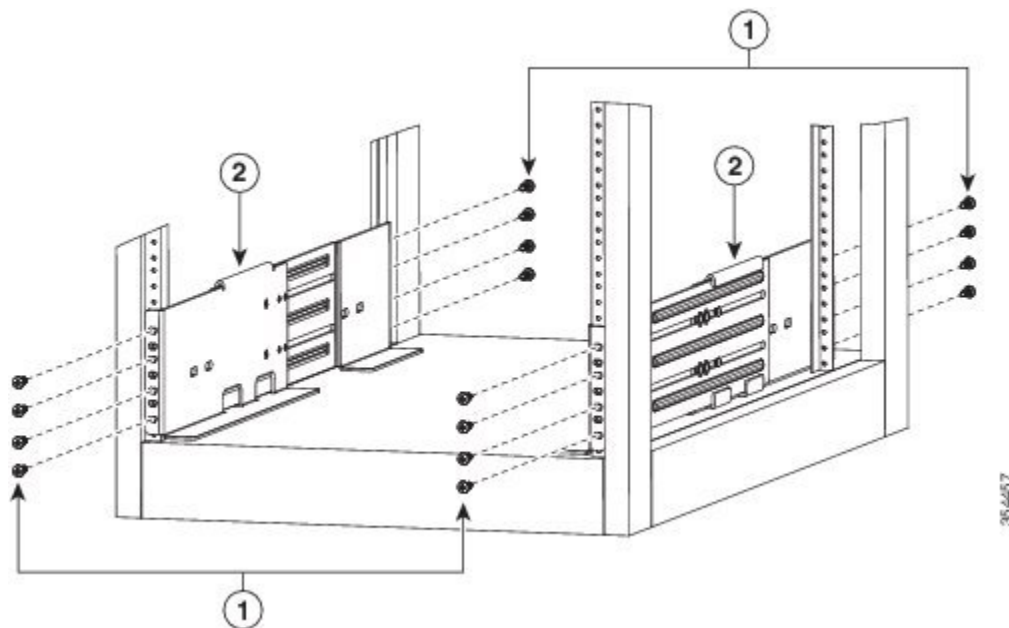

1	M6 x 19 mm (or 12-24 x 3/4 in.) Phillips screws (8 per rail)
2	Adjustable bottom-support rails (2)

**Note** At least three of the screw holes on each end of the bottom-support rail align to the mounting rail. Use at least three screws (four if possible) on each end of each bottom support rail.

**Step 3** Repeat Step 1 and Step 2 to attach the other bottom-support rail to the rack. The other rail/bracket need to be flipped 180 degrees and installed to the other side of the rack because both the left and right sides are the same rail/bracket.

**Note** Make sure that the two bottom-support rails are level with one another. If they are not level, adjust the higher rail down to the level of the lower rail.

When the bottom-support rails are installed at the lowest possible RU and are level, you are ready to install the chassis in the rack or cabinet.

---

## Installing the Cisco MDS 9706 Chassis in a Two-Post Rack

To Install MDS 9706 Chassis in a Two-Post Rack, perform the following steps:

### Before you begin

- Verify that the chassis shipment is complete and undamaged.
- Verify that a two-post rack is installed and secured to the subfloor.



---

**Warning** Stability hazard. The rack stabilizing mechanism must be in place, or the rack must be bolted to the floor before you slide the unit out for servicing. Failure to stabilize the rack can cause the rack to tip over. Statement 1048

---

- Verify that the bottom-support rails have been attached to the lowest possible RU in the rack or cabinet and there is 9 RU (15.75 inches [40.0 cm]) of space above the rails to install the chassis.
- If there are other devices in the rack, verify that the devices that are heavier than this chassis are installed below where you are going to install the chassis and lighter devices are installed above where you are going to install the chassis.
- Verify that the data center ground is accessible where you are installing the chassis.
- Verify that you have the following tools and equipments:
  - Mechanical lift capable of lifting the full weight of the chassis and its installed modules



---

**Note** Fully loaded, the Cisco MDS 9706 chassis can weigh up to 325 lb (147.5 kg). You can lighten the chassis for easier moving by removing its power supplies, fan modules, and fabric modules. To determine the full weight of the chassis and the appropriate weight rating for the mechanical lift, see [Appendix 6, “Technical Specifications”](#).

---



---

**Caution** You must use a mechanical lift or floor jack to elevate a switch weighing over 120 pounds (55 kg).

---

- Manual Phillips-head torque screwdriver



---

**Note** You should also have at least two persons to push the chassis when you slide it onto the rack.

---



---

**Note** To prevent bodily injury when mounting or servicing this unit in a rack, you must take special precautions to ensure that the system remains stable. The following guidelines are provided to ensure your safety:

- This unit should be mounted at the bottom of the rack if it is the only unit in the rack.
  - When mounting this unit in a partially filled rack, load the rack from the bottom to the top with the heaviest component at the bottom of the rack.
  - If the rack is provided with stabilizing devices, install the stabilizers before mounting or servicing the unit in the rack.
- 

## Procedure

### Step 1

If you need to make the chassis as light as possible for moving, you can optionally remove the fabric modules, fan modules, and power supplies.

a) To remove a power supply, follow these steps:

1. Push and hold the release handle on the power supply to the left.
2. Pull the power supply about two inches (about 5 cm) out of the chassis.
3. Place one hand under the power supply to support its weight and pull the power supply out of the chassis.
4. Place the power supply on an antistatic surface.

b) To remove a fan module, follow these steps:

1. Unscrew the four captive screws on the front of the fan module (one captive screw in each corner of the front of the fan module).
2. Hold both handles on the fan module with both of your hands and pull the fan module out of the chassis.
3. Place the fan module on an antistatic surface.

c) To remove a fabric module, follow these steps:

**Note** Before you can remove a fabric module, you must remove the fan module that is installed in front of it.

1. Press the lever eject button found in the middle of the front of the module.
2. Rotate both of the levers away from the fabric module.

3. When the other end of each lever is no longer holding onto the chassis, pull the two levers to slide the module a couple inches out of the chassis.
4. Rotate the two levers back to the fabric module. Each lever will click when locked in place.
5. Place one hand on the front of the module and place your other hand under the module to support its weight.
6. Slide the module out of the chassis and place the module on an antistatic surface.

**Step 2** Load the chassis onto a mechanical lift or floor jack as follows:

- a. Position the mechanical lift next to the shipping pallet that holds the chassis.
- b. Elevate the lift platform to the level of the bottom of the chassis (or no more than 1/4 inch [0.635 cm] below the bottom of the chassis).
- c. Use two persons to slide the chassis fully onto the lift so that the side of the chassis touches or is close to the vertical rails on the lift. Make sure that the front and rear of the chassis are unobstructed so you can easily push the chassis into the rack.

**Warning** To prevent personal injury or damage to the chassis, never attempt to lift or tilt the chassis using the handles on modules (such as power supplies, fans, or cards); these types of handles are not designed to support the weight of the unit. Statement 1032

**Caution** To lift the chassis, use a mechanical lift. Do not use the handles on the side of the chassis (the handles are not rated for lifting over 200 pounds [91 kg]). Use the side handles for only repositioning the chassis after it is already on the mechanical lift or in the rack or cabinet.

**Step 3** Use the mechanical lift to move and align the rear of the chassis to the front of the rack or cabinet. Make sure that the bottom of the chassis is elevated to the height of the bottom-support rails or no more than 1/4 inch (0.6 cm) above the rails.

**Step 4** Push the chassis halfway onto the rack or cabinet.

Use two persons to push the chassis onto the bottom-support rails. Push the lower half of the front side of the chassis so that the back side enters the rack first, and push until the chassis is halfway onto the rack (see the following figure). Ensure that the chassis does not get caught on any of the expansion edges of the bottom-support rail.

Figure 34: Moving a Chassis onto a Rack or Cabinet - Cisco MDS 9706 Chassis

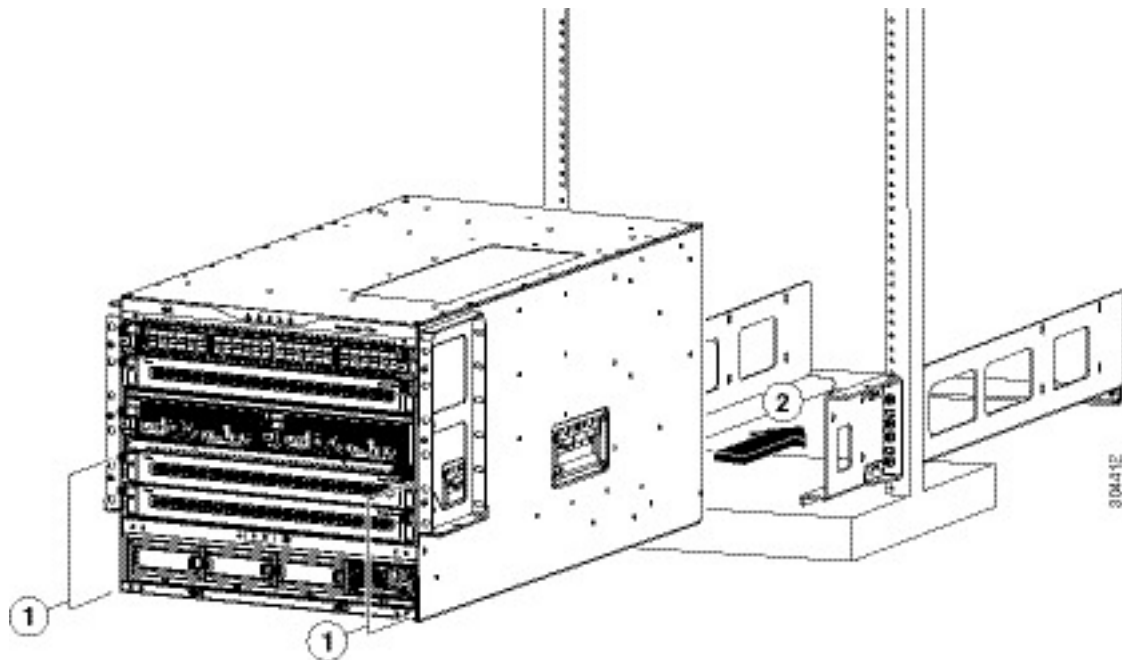

1	Push the sides of the lower half of the front side of the chassis.	2	Push the chassis into the rack until its mounting bracket touches the vertical mounting rails on the rack.
---	--	---	--

**Tip** To adjust the placement of the chassis on the bottom-support rails, you can use the handles on the sides of the chassis.

**Step 5** If the mechanical lift is raised above the height of the bottom-support rails, gently lower it to the level of the rails or no more than 1/4 inch (0.6 cm) below the rails.

This action helps to prevent the bottom of the chassis from getting caught on the bottom expansion edges of the bottom-support rails.

**Step 6** Push the chassis all the way onto the rack so that the vertical mounting brackets on the chassis come in contact with the vertical mounting rails on the rack.

**Step 7** Use seven M6 x 19 mm or 24 x 3/4-inch screws to attach each of the two vertical mounting brackets on the chassis to the two vertical mounting rails on the rack (total of 14 screws). See the following figure.

Figure 35: Attaching the Chassis to the Rack

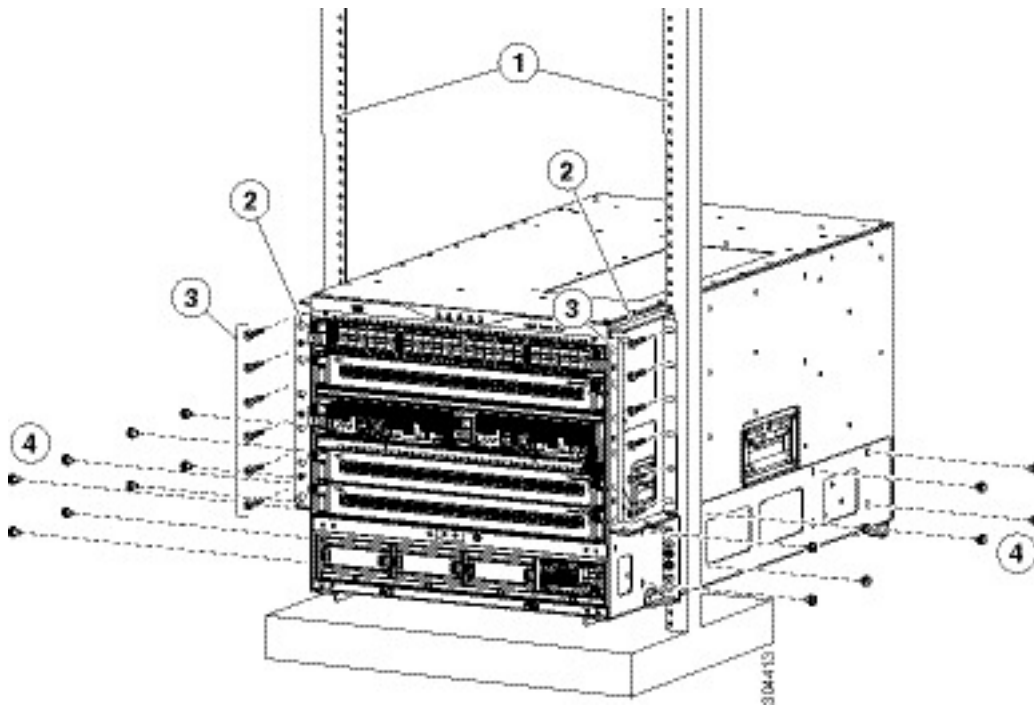

1	Vertical mounting rails on the rack	3	Six M6 x 19 mm or 10-24 x 3/4 in. Phillips screws used to attach each side bracket to a front mounting rail (use a total of 12 screws)
2	Mounting brackets for two-post racks	4	Eight M6 x 10 mm screws used to attach each bottom support rail to the chassis (use a total of 16 screws for both rails)

**Step 8** Use eight M6 x 10 mm screws to attach the bottom-support rails to the chassis (use a total of 16 screws for both bottom support rails). See previous image.

**Step 9** If you removed any fabric modules before moving the chassis, replace each one in the chassis as follows:

- a. Holding the front of the fabric module (the side with the LEDs), turn the module so that the front side is vertical.
 

**Note** The top of the module has an alignment bracket running from the rear to the front. The electrical connectors will be at the bottom.
- b. Align the rear of the fabric module to an open fabric slot and insert the bracket on top of the module into the track at the top of the slot.
 

**Note** If there are only three fabric modules to install, install them in fabric slots 1, 3, and 5, and be sure that there are blank filler plates installed in the open slots.
- c. Slide the module part way into the slot.
- d. Press the ejector button on the front of the module, to release the levers from the front of the module.

- e. Rotate the levers away from the front of the module and hold them while sliding the module all the way into the slot.
- f. Simultaneously rotate both levers to the front of the module. They click when locked to the front of the module.

**Step 10**

If you have removed any fan modules before moving the chassis, reinstall each one in the chassis as follows:

- a. Holding each of the two handles on the fan module with your two hands, align the fan module to an open fan module slot.

**Note** The two alignment brackets on top of the fan module should align to two tracks at the top of the slot.

- b. Slide the fan module into the slot until the front of the fan module comes in contact with the rear of the chassis.

**Note** The two alignment pins on the fan module (on the top and one on the bottom) should go into holes in the chassis and the four captive screws on the fan module should align to screw holes in the chassis.

- c. Screw in the four captive screws to the chassis and tighten each screw to 8 in-lb (0.9 N·m).

**Step 11**

If you have removed any power supplies before moving the chassis, reinstall each one as follows:

- a. Determine which power supply slots to fill and ensure that each of those slots is open.

If you are using the combined or power supply redundancy mode, you can use any slot for the power supply that you are installing.

If you are using the input-source or full redundancy mode, you must group the power supplies that are to be connected to the same grid on either the left or right power supply slots in the chassis (that is, place the power supplies for grid A in slots 1 or 2 or both slots and place the power supplies for grid B in slots 3 or 4 or both slots).

For information on the power supplies supported by Cisco MDS 9700 series switches, see the [Power Supply](#) section under the Product Overview chapter.

- b. Place one hand on the front of the power supply and place your other hand under it to support its weight.

- c. Align the power supply to an open power supply slot.

**Note** The alignment bracket on top of the power supply should align to a track at the top of the slot and a bar at the bottom of the power supply should be guided by a track at the bottom of the slot.

**Step 12**

Slide the power supply all the way into the slot until its release handle clicks and the module stops.

## Installing the Cisco MDS 9710 and MDS 9718 Series Switch on a Four-Post Rack or Cabinet

This section is applicable to the Cisco MDS 9710 and Cisco MDS 9718 switches.

**Before You Begin**

- Verify that the chassis shipment is complete and undamaged.
- Verify that a rack or cabinet is installed and secured to the subfloor.



**Warning** **Stability hazard**

The rack stabilizing mechanism must be in place, or the rack must be bolted to the floor before you slide the unit out for servicing. Failure to stabilize the rack can cause the rack to tip over. Statement 1048

- Verify that the bottom-support rails have been attached to the lowest possible RU in the rack or cabinet and there is 14 RU (24.5 inches [62.2 cm]) of space above the rails to install the chassis.
- For Cisco MDS 9718 chassis, verify that the bottom-support rails have been attached to the lowest possible RU in the rack or cabinet and there is 25 RU (43.75 inches [111 cm]) of space above the rails to install the chassis.
- If there are other devices in the rack, verify that the devices that are heavier than this chassis are installed below where you are going to install the chassis and lighter devices are installed above where you are going to install the chassis.
- Verify that the data center ground is accessible where you are installing the chassis.
- Verify that you have the following tools and equipment:
  - Mechanical lift capable of lifting the full weight of the chassis and its installed modules



**Caution** If the rack is on wheels, ensure that the brakes are engaged or that the rack is otherwise stabilized. If connecting a Cisco MDS 9700 Series switch to a 110-VAC power system, ensure that sufficient power is provided to meet the chassis power requirements for the number of modules installed.



**Caution** All power supplies must be grounded. The receptacles of the AC power cables used to provide power to the chassis must be the grounding type, and the grounding conductors should connect to protective earth ground at the service equipment. For a Cisco MDS 9700 Series switch with a DC power supply, a grounding cable must be connected to the terminal block.

When connected to 220 VAC, the 3000-W AC power supplies DS-CAC97-3KW for the Cisco MDS 9700 Series switch are designed to provide an output power of 3000 W to power the modules and fans. When connected to a 110 VAC power system, the power supply provides approximately 1450 W. In this case, and if the power supplies are used in redundant rather than combined mode, they might not provide adequate power, depending on the number of modules loaded in the chassis.

If a 110-VAC input is chosen, a 110-VAC power cord (CAB-7513AC=) must be ordered separately.



**Warning** When installing or replacing the unit, the ground connection must always be made first and disconnected last. Statement 1046



---

**Note** Fully loaded, the Cisco MDS 9710 chassis can weigh up to 449.5 lb (203.8 kg), and the Cisco MDS 9718 chassis can weigh up to 923 lb (419 kg). You can lighten the chassis for easier moving by removing its power supplies, fan modules, and fabric modules. To determine the full weight of the chassis and the appropriate weight rating for the mechanical lift, see “Weights and Quantities for the Chassis, Modules, Fan Modules, and Power Supplies”.

---



---

**Caution** You must use a mechanical lift or floor jack to elevate a switch weighing over 120 pounds (55 kg).

---

- Phillips-head torque screwdriver
- Bottom-support rails kit (shipped with the accessory kit)

Part of this kit has already been used to install the bottom-support rails. You should still have 14 12-24 x 3/4-inch or M6 x 19 mm Phillips screws, which are required for attaching the chassis to the rack.



---

**Note** You should also have at least two persons to push the chassis when you slide it onto the rack.

---



---

**Note** To prevent bodily injury when mounting or servicing this unit in a rack, you must take special precautions to ensure that the system remains stable. The following guidelines are provided to ensure your safety:

- This unit should be mounted at the bottom of the rack if it is the only unit in the rack.
- When mounting this unit in a partially filled rack, load the rack from the bottom to the top with the heaviest component at the bottom of the rack.
- If the rack is provided with stabilizing devices, install the stabilizers before mounting or servicing the unit in the rack.

Statement 1006

---

## Installing the Cisco MDS 9700 Series Switch on a Four-Post Rack or Cabinet

To install MDS 9700 Series switch on a four-post rack or cabinet, perform the following steps:

## Procedure

### Step 1

If you need to make the chassis as light as possible for moving, you can optionally remove the fabric modules, fan modules, and power supplies.

- a) To remove a power supply, follow these steps:
  1. Slide the handle in the middle of the ejector lever towards the end of the lever and rotate the lever away from the power supply.
  2. Pull the power supply a couple of inches (about 5 cm) out of the chassis.
  3. Place one hand under the power supply to support its weight and pull the power supply out of the chassis.
  4. Place the power supply on an antistatic surface.
- b) To remove a fan module, follow these steps:
  1. Unscrew the four captive screws on the front of the fan module (one captive screw in each corner of the front of the fan module).
  2. Hold both handles on the fan module with both of your hands and pull the fan module out of the chassis.
  3. Place the fan module on an antistatic surface.

- c) To remove a fabric module, follow these steps:

**Note** Before you can remove a fabric module, you must remove the fan module that is installed in front of it.

1. Press the lever eject button found in the middle of the front of the module.
2. Rotate both of the levers away from the fabric module.
3. When the other end of each lever is no longer holding onto the chassis, pull the two levers to slide the module a couple inches out of the chassis.
4. Rotate the two levers back to the fabric module. Each lever will click when locked in place.
5. Place one hand on the front of the module and place your other hand under the module to support its weight.
6. Slide the module out of the chassis and place the module on an antistatic surface.

### Step 2

Load the chassis onto a mechanical lift or floor jack as follows:

- a. Position the mechanical lift next to the shipping pallet that holds the chassis.
- b. Elevate the lift platform to the level of the bottom of the chassis (or no more than 1/4 inch [0.635 cm] below the bottom of the chassis).
- c. Use two persons to slide the chassis fully onto the lift so that the side of the chassis touches or is close to the vertical rails on the lift. Make sure that the front and rear of the chassis are unobstructed so you can easily push the chassis into the rack.

**Warning** To prevent personal injury or damage to the chassis, never attempt to lift or tilt the chassis using the handles on modules (such as power supplies, fans, or cards); these types of handles are not designed to support the weight of the unit. Statement 1032

**Caution** To lift the chassis, use a mechanical lift. Do not use the handles on the side of the chassis (the handles are not rated for lifting over 200 pounds [91 kg]). Use the side handles for only repositioning the chassis after it is already on the mechanical lift or in the rack or cabinet.

**Step 3** Use the mechanical lift to move and align the rear of the chassis to the front of the rack or cabinet. Make sure that the bottom of the chassis is elevated to the height of the bottom-support rails or no more than 1/4 inch (0.6 cm) above the rails.

**Note** The Cisco MDS 9700 Series switch has the front-to-back cold-aisle and hot-aisle air flow design. We recommend that you maintain a minimum air space of 7 inches (30.5 cm) at the chassis front and back air vents.

**Step 4** Push the chassis halfway onto the rack or cabinet.

Figure 36: Moving a Chassis onto a Rack or Cabinet - Cisco MDS 9710 Chassis

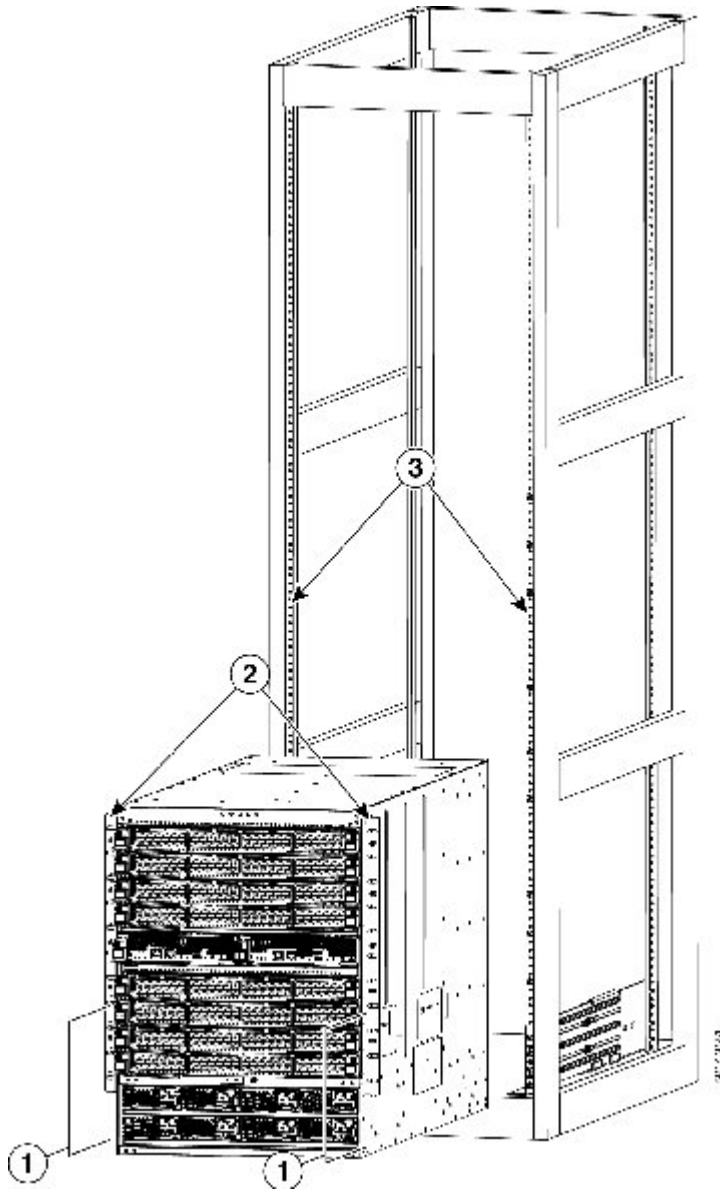

1	Push the sides of the lower half of the front side of the chassis.	3	Rack vertical mounting rails.
2	Chassis mounting brackets.		

Use two persons to push the chassis onto the bottom-support rails. Push the lower half of the front side of the chassis so that the back side enters the rack first, and push until the chassis is halfway onto the rack. See the following image. Ensure that the chassis does not get caught on any of the expansion edges of the bottom-support rail.

Figure 37: Moving a Chassis onto a Rack or Cabinet - Cisco MDS 9718 Chassis

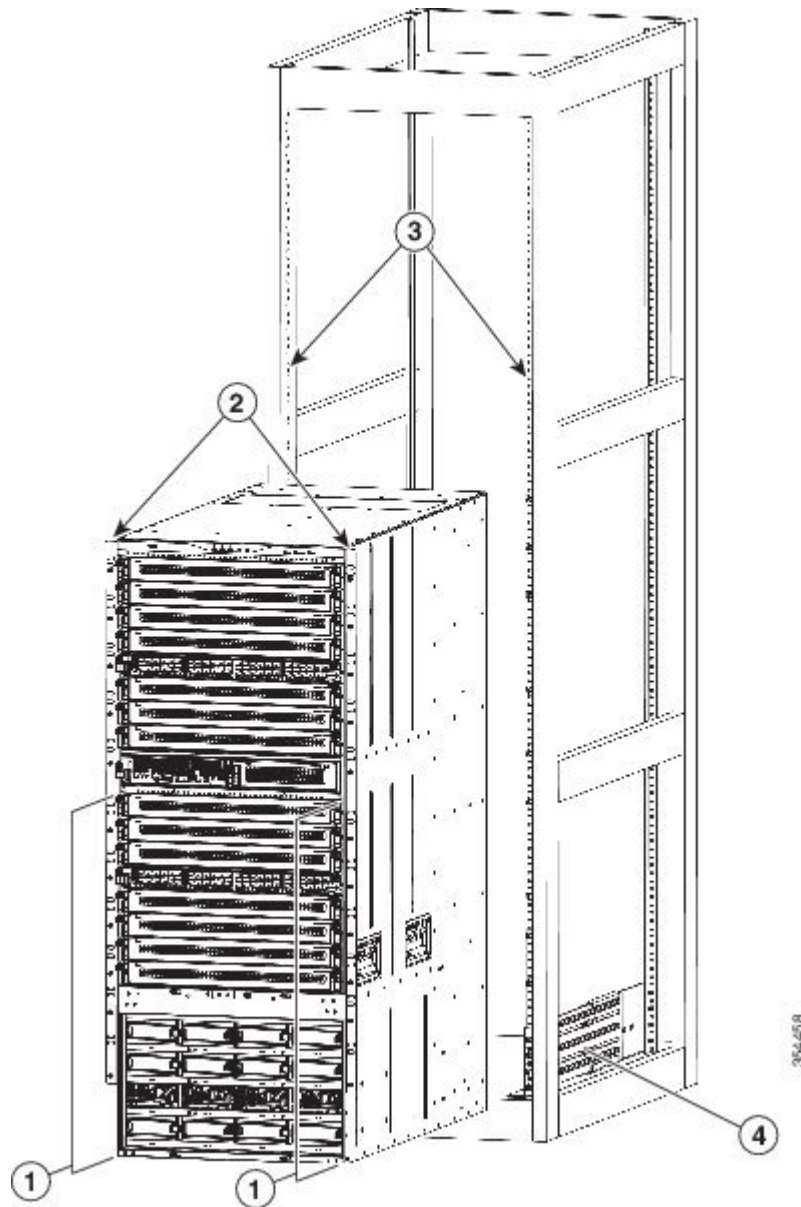

1	Push the sides of the lower half of the front side of the chassis (do not push on any of the modules or module handles).	3	Rack vertical mounting rails.
2	Chassis mounting brackets.	4	Bottom support rails

**Tip** To adjust the placement of the chassis on the bottom-support rails, you can use the handles on the sides of the chassis.

**Step 5** If the mechanical lift is raised above the height of the bottom-support rails, gently lower it to the level of the rails or no more than 1/4 inch (0.6 cm) below the rails.

This action helps to prevent the bottom of the chassis from getting caught on the bottom expansion edges of the bottom-support rails.

- Step 6** Push the chassis all the way onto the rack so that the vertical mounting brackets on the chassis come in contact with the vertical mounting rails on the rack.
- Step 7** Use seven M6 x 19 mm or 24 x 3/4-inch screws to attach each of the two vertical mounting brackets on the chassis to the two vertical mounting rails on the rack (total of 14 screws). See the following image.

**Figure 38: Attaching the Chassis to the Rack - Cisco MDS 9710 Chassis**

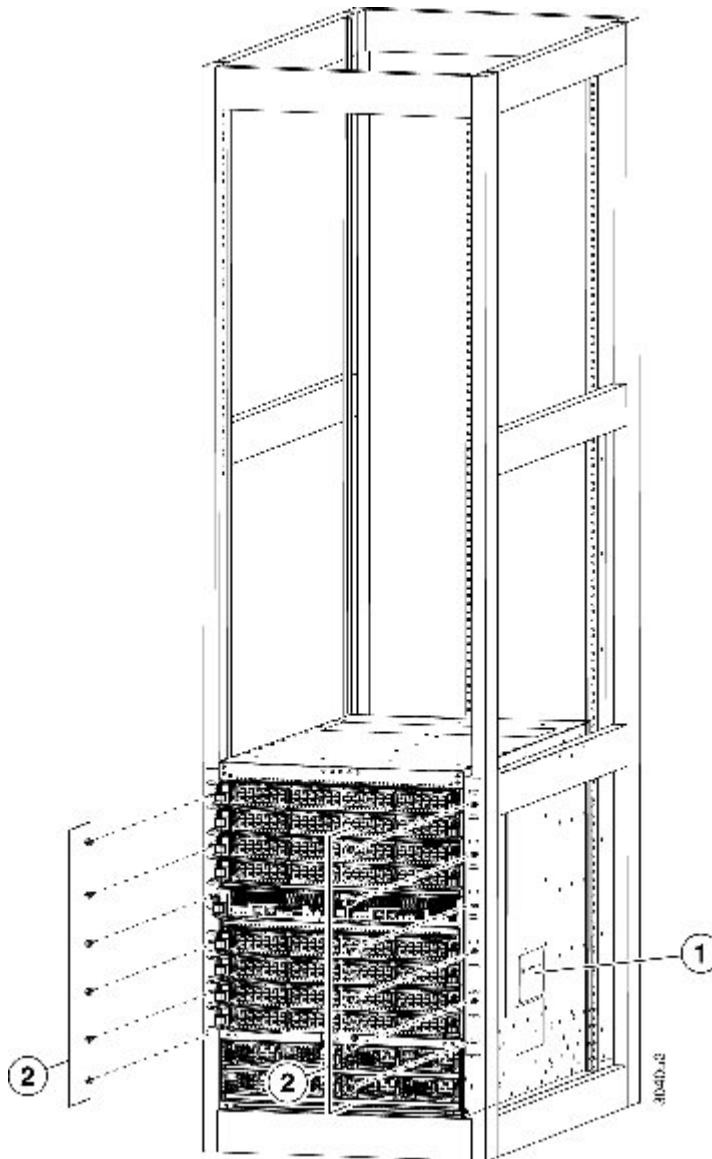

1	Handles used to adjust the chassis placement	2	Nine M6 x 19 mm or 10-24 x 3/4 in. Phillips screws used to attach each side bracket to a front mounting rail (use a total of 18 screws)
---	--	---	---

Figure 39: Attaching the Chassis to the Rack - Cisco MDS 9718 Chassis

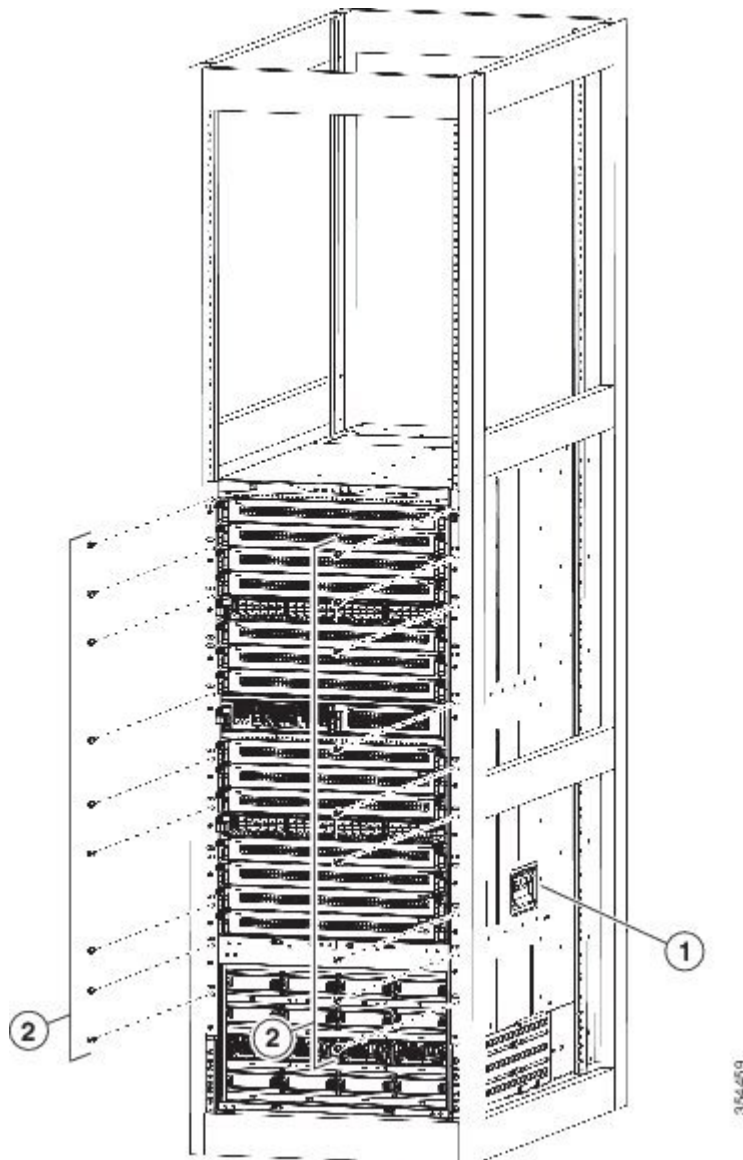

1	Handles used to adjust the chassis placement	2	Nine M6 x 19 mm or 10-24 x 3/4 in. Phillips screws used to attach each side bracket to a front mounting rail (use a total of 18 screws)
---	--	---	---

**Step 8**

If you removed any fabric modules before moving the chassis, replace each one in the chassis as follows:

- a. Holding the front of the fabric module (the side with the LEDs), turn the module so that the front side is vertical.

**Note** The top of the module has an alignment bracket running from the rear to the front. The electrical connectors will be at the bottom.



- b. Align the rear of the fabric module to an open fabric slot and insert the bracket on top of the module into the track at the top of the slot.

**Note** If there are only three fabric modules to install, install them in fabric slots 1, 3, and 5, and be sure that there are blank filler plates installed in the open slots.

- c. Slide the module part way into the slot.
- d. Press the ejector button on the front of the module, to release the levers from the front of the module.
- e. Rotate the levers away from the front of the module and hold them while sliding the module all the way into the slot.
- f. Simultaneously rotate both levers to the front of the module. They click when locked to the front of the module.

### Step 9

If you removed any fan modules before moving the chassis, reinstall each one in the chassis as follows:

- a. Holding each of the two handles on the fan module with your two hands, align the fan module to an open fan module slot.

**Note** The two alignment brackets on top of the fan module should align to two tracks at the top of the slot.

- b. Slide the fan module into the slot until the front of the fan module comes in contact with the rear of the chassis.

**Note** The two alignment pins on the fan module (on the top and one on the bottom) should go into holes in the chassis and the four captive screws on the fan module should align to screw holes in the chassis.

- c. Screw in the four captive screws to the chassis and tighten each screw to 8 in-lb (0.9 N·m).

### Step 10

If you removed any power supplies before moving the chassis, reinstall each one as follows:

- a. Determine which power supply slots to fill and ensure that each of those slots is open.
- b. If you are using the combined or power supply redundancy mode, you can use any slot for the power supply that you are installing.

If you are using input-source or full redundancy mode, you must group the power supplies that are to be connected to the same grid on either the left or right power supply slots in the chassis (that is, place the power supplies for grid A in slots 1 or 2 or both slots and place the power supplies for grid B in slots 3 or 4 or both slots).

- c. Place one hand on the front of the power supply and place your other hand under it to support its weight.
- d. Align the power supply to an open power supply slot.

**Note** The alignment bracket on top of the power supply should align to a track at the top of the slot and a bar at the bottom of the power supply should be guided by a track at the bottom of the slot.

- e. Slide the power supply all the way into the slot until it stops.
- f. Slide the handle in the middle of the ejector lever toward the end of the lever and rotate the lever to the front of the power supply. Release the middle handle.

**Note** The lever should grab the inside of the slot and push the power supply onto its mid-plane connectors.

- If you are using the combined power or power-supply redundancy mode, you can fill any power supply slot with the power supplies. If you are using input-source or full redundancy modes, you must place half of the power supplies in slots 1 and 2, and you must place the other half of the power supplies in slots 3 and 4 (half will be used for available power and the other half will be used for redundant power).
  - In a single phase AC power supply unit, connection of multiple phases from the same three-phase source is supported and direct connection of three-phase is not supported.
- g. Screw in the two captive screws on the front of the power supply to the chassis. Tighten each screw to 8 in-lb (0.9 N·m)

## System Grounding

This section describes the need for system grounding and explains how to prevent damage from electrostatic discharge.

### Proper Grounding Practices

Grounding is one of the most important parts of equipment installation. Proper grounding practices ensure that the buildings and the installed equipment within them have low-impedance connections and low-voltage differentials between chassis. When you properly ground systems during installation, you reduce or prevent shock hazards, equipment damage due to transients, and data corruption. [Table 3-1](#) lists grounding best practices.

**Table 18: Grounding Best Practices**

Environment	Electromagnetic Noise Severity Level	Grounding Recommendations
Commercial building is subjected to direct lightning strikes.  For example, some places in the United States, such as Florida, are subject to more lightning strikes than other areas.	High	All lightning protection devices must be installed in strict accordance with manufacturer recommendations. Conductors carrying lightning current should be spaced away from power and data lines in accordance with applicable recommendations and codes. Appropriate grounding practices must be closely followed.
Commercial building is located in an area where lightning storms frequently occur but is not subject to direct lightning strikes.	High	Appropriate grounding practices must be closely followed.
Commercial building contains a mix of information technology equipment and industrial equipment, such as welding.	Medium to high	Appropriate grounding practices must be closely followed.

Existing commercial building is not subject to natural environmental noise or man-made industrial noise. This building contains a standard office environment. This installation has a history of malfunction due to electromagnetic noise.	Medium	Appropriate grounding practices must be closely followed. Determine source and cause of noise if possible, and mitigate as closely as possible at the noise source or reduce coupling from the noise source to the victim equipment.
New commercial building is not subject to natural environmental noise or man-made industrial noise. This building contains a standard office environment.	Low	Appropriate grounding practices should be followed as closely as possible. Electromagnetic noise problems are not anticipated, but installing a best practice grounding system in a new building is often the least expensive route and the best way to plan for the future.
Existing commercial building is not subject to natural environmental noise or man-made industrial noise. This building contains a standard office environment.	Low	Appropriate grounding practices should be followed as much as possible. Electromagnetic noise problems are not anticipated, but installing a best practice grounding system is always recommended.



**Note** In all situations, grounding practices must comply with local National Electric Code (NEC) requirements or local laws and regulations.



**Note** Always ensure that all the modules are completely installed and that the captive installation screws are fully tightened. In addition, ensure that all I/O cables and power cords are properly seated. These practices are normal installation practices and must be followed in all installations.

## Preventing Electrostatic Discharge Damage

Electrostatic discharge (ESD) damage, which can occur when modules or other Field Replaceable Units (FRU - a circuit board, part, or an assembly which can be easily removed and replaced without having to send the entire product to a repair facility.) are improperly handled, results in intermittent or complete failures. Modules consist of printed circuit boards that are fixed in metal carriers. Electromagnetic interference (EMI) shielding and connectors are integral components of the carrier. Although the metal carrier helps protect the board from ESD. Always wear an ESD grounding strap when handling modules.

Follow these guidelines for preventing ESD damage:

- Always wear an ESD wrist strap and ensure that it makes maximum contact with bare skin. ESD grounding straps are available with banana plugs, metal spring clips, or alligator clips. All Cisco MDS 9700 Series devices are equipped with a banana plug connector (identified by the ground symbol next to the connector) somewhere on the front panel. We recommend that you use a personal ESD grounding strap equipped with a banana plug.
- If you choose to use the disposable ESD wrist strap supplied with most FRUs or an ESD wrist strap equipped with an alligator clip, you must attach the system ground lug to the chassis in order to provide a proper grounding point for the ESD wrist strap.



---

**Note** This system ground is also referred to as the network equipment building system (NEBS) ground.

---

- If your chassis does not have the system ground attached, you must install the system ground lug. For installation instructions and location of the chassis system ground pads, see [“Establishing the System Ground” section](#).



---

**Note** You do not need to attach a supplemental system ground wire to the system ground lug; the lug provides a direct path to the bare metal of the chassis.

---

## Establishing the System Ground

This section describes how to connect a system ground to the MDS 9700 Series switch.



---

**Note** This system ground is also referred to as the network equipment building system (NEBS) ground.

---

You must use the system (NEBS) ground on both AC- and DC-powered systems if you are installing this equipment in a U.S. or European Central Office.

The system (NEBS) ground provides additional grounding for EMI shielding requirements and grounding for the low-voltage supplies (DC-DC converters) on the modules and is intended to satisfy the Telcordia Technologies NEBS requirements for supplemental bonding and grounding connections. You must observe the following system grounding guidelines for your chassis:

- You must install the system (NEBS) ground connection with any other rack or system power ground connections that you make. The system ground connection is required if this equipment is installed in a U.S. or European Central Office.
- You must connect both the system (NEBS) ground connection and the power supply ground connection to an earth ground. The system (NEBS) ground connection is required if this equipment is installed in a U.S. or European Central Office.
- For Cisco MDS 9700 Series devices that are equipped with DC-input power supplies, you must install the system (NEBS) ground before you attach the source DC power cables to the DC PEM. If the chassis is powered up, you must power down the chassis before attaching the system (NEBS) ground. If you are installing the system (NEBS) ground on models of the Cisco MDS 9700 chassis that are equipped with either AC-input or DC-input power supplies, you do not need to power down the chassis.



---

**Note** The system (NEBS) ground serves as the primary safety ground for the MDS 9700 Series switch that are equipped with DC-input PEMs. The DC-input power supplies for these chassis do not have a separate ground.

---

## Required Tools and Equipment

After you install the system ground lug, follow these steps to correctly attach the ESD wrist strap:

### Before you begin

To connect the ground system, you need the following tools and materials:

- Grounding lug—A two-hole standard barrel lug. Supports up to 6 AWG wire. Supplied as part of accessory kit.
- Grounding screws—Two M4 x 8mm (metric) pan-head screws. Supplied as part of the accessory kit.
- Grounding wire—Not supplied as part of accessory kit. The grounding wire should be sized according to local and national installation requirements. Depending on the power supply and system, a 6 AWG copper conductor is required for U.S. installations. Commercially available 6 AWG wire is recommended. The length of the grounding wire depends on the proximity of the switch to proper grounding facilities.



---

**Note** For safety on a ground fault, we recommend that you should avoid using a grounding wire that is smaller than the power wire. The grudging wire must be sized to meet local and national standard for installation requirements.

---

- No. 1 Phillips screwdriver.
- Crimping tool to crimp the grounding wire to the grounding lug.
- Wire-stripping tool to remove the insulation from the grounding wire.

## Procedure

---

- Step 1** Attach the ESD wrist strap to bare skin as follows:
- a. If you are using the ESD wrist strap supplied with the FRUs, open the wrist strap package and unwrap the ESD wrist strap. Place the black conductive loop over your wrist and tighten the strap so that it makes good contact with your bare skin.
  - b. If you are using an ESD wrist strap equipped with an alligator clip, open the package and remove the ESD wrist strap. Locate the end of the wrist strap that attaches to your body and secure it to your bare skin.
- Step 2** Grasp the spring or alligator clip on the ESD wrist strap and momentarily touch the clip to a bare metal spot (unpainted surface) on the rack. We recommend that you touch the clip to an unpainted rack rail so that any built-up static charge is then safely dissipated to the entire rack.
- Step 3** To plug the strap into the port (and alternatively clip an alligator clip onto the grounding lug screws) attach either the spring clip or the alligator clip to the ground lug screw.
- a. If you are using the ESD wrist strap that is supplied with the FRUs, squeeze the spring clip jaws open, position the spring clip to one side of the system ground lug screw head, and slide the spring clip over the lug screw head so that the spring clip jaws close behind the lug screw head.

**Note** The spring clip jaws do not open wide enough to fit directly over the head of the lug screw or the lug barrel.

- b. If you are using an ESD wrist strap that is equipped with an alligator clip, attach the alligator clip directly over the head of the system ground lug screw or to the system ground lug barrel.
- c. Follow these additional guidelines when handling modules:
  - Handle carriers by available handles or edges only; avoid touching the printed circuit boards or connectors.
  - Place a removed component board-side-up on an antistatic surface or in a static shielding container. If you plan to return the component to the factory, immediately place it in a static shielding container.
  - Never attempt to remove the printed circuit board from the metal carrier.

**Caution** For safety reasons, check the resistance value of the antistatic strap periodically. The measurement should be between 1 and 10 megohm (Mohm).

---



## CHAPTER 5

# Connecting the Cisco MDS 9700 Series Switches

This chapter includes the following sections:

- [Connection Guidelines, on page 105](#)
- [Preparing for Network Connections, on page 106](#)
- [Connecting to the Console Port, on page 106](#)
- [Connecting to the MGMT 10/100/1000 Ethernet Port, on page 107](#)
- [Removing and Installing SFP+ and QSFP+ Transceivers, on page 108](#)
- [Removing and Installing Cables into SFP+ or QSFP+ Transceivers, on page 111](#)
- [Maintaining SFP+ and QSFP+ Transceivers and Fiber-Optic Cables, on page 112](#)

## Connection Guidelines

The Cisco MDS 9700 Series switch provides the following types of ports:

- Console port (supervisor modules) —An RS-232 port that you can use to create a local management connection.
- MGMT 10/100/1000 Ethernet port (supervisor module)—An Ethernet port that you can use to access and manage the switch by IP address, such as through Cisco Data Center Network Manager (DCNM).
- Fibre Channel ports (switching modules)—Fibre Channel (FC) ports that you can use to connect to the SAN or for in-band management.
- Fibre Channel over Ethernet ports (switching modules)—Fibre Channel over Ethernet (FCoE) ports that you can use to connect to the SAN or for in-band management.

The Cisco MDS 9700 Series switch has two USB drives (in each Supervisor-1 module). A simple USB interface that allows you to connect to different devices supported by Cisco MDS NX-OS. In the supervisor module, there are two USB drives, Slot 0 and LOG FLASH. The LOG FLASH and Slot 0 USB ports use different formats for their data.



### Caution

When running power and data cables in overhead or subfloor cable trays, we strongly recommend that power cables and other potential noise sources be located as far away as is practical from network cabling that terminates on Cisco equipment. In situations where long parallel cable runs cannot be separated by at least 3.3 ft (1 m), we recommend shielding any potential noise sources by housing them in a grounded metallic conduit.

## Preparing for Network Connections

When preparing your site for network connections to the Cisco MDS 9700 Series switch, consider the following for each type of interface, and obtain all of the required equipment before connecting the ports:

- Cabling required for each interface type
- Distance limitations for each signal type
- Additional interface equipment required

## Connecting to the Console Port

To connect the console port to a computer terminal, follow these steps:

### Before you begin

- The console port, labeled Console, is an RS-232 port with an RJ-45 interface. It is an asynchronous (async) serial port; any device connected to this port must be capable of asynchronous transmission.

This port must be used to initially configure the management IP address and other parameters before connecting the switch to the network for the first time.



---

**Caution** The console port can be used to connect to a modem, however, we recommend using the COM1 port for this purpose. If you decide to connect the console port to a modem, do not connect it while the switch is booting; connect either before powering the switch on or after the switch has completed the boot process.

---

- You can use the console port to perform the following functions:
  - Configure the Cisco MDS 9710 Director from the CLI.
  - Monitor network statistics and errors.
  - Configure SNMP agent parameters.
  - Download software updates.



---

**Note** To connect the console port to a computer terminal, the computer must support VT100 terminal emulation. The terminal emulation software—frequently an application such as HyperTerminal or Procomm Plus—makes communication between the switch and computer possible during setup and configuration.

---



## Procedure

- 
- Step 1** Configure the terminal emulator program to match the following default port characteristics: 9600 baud, 8 data bits, 1 stop bit, no parity.
- Step 2** Connect the supplied RJ-45 to DP-25 female adapter. We recommend that you use the adapter and cable provided with the switch.
- Step 3** Connect the console cable (a rollover RJ-45 to RJ-45 cable) to the console port or the RJ-45 to DP-25 adapter (depending on your computer) at the computer serial port.
- 

# Connecting to the MGMT 10/100/1000 Ethernet Port

To connect the MGMT 10/100/1000 Ethernet port to an external hub, switch, or router, follow these steps:

### Before you begin

The Supervisor-1 module supports an autosensing MGMT 10/100/1000 Ethernet port (labeled “MGMT 10/100/1000”) and has an RJ-45 interface. You can use this port to access and manage the switch by IP address, such as through DCNM.



---

**Caution** To prevent an IP address conflict, do not connect the MGMT 10/100/1000 Ethernet port to the network until the initial configuration is complete. For more information, see the Cisco MDS 9000 Family NX-OS Fundamentals Configuration Guide.

---

## Procedure

- 
- Step 1** Connect the appropriate modular cable to the MGMT 10/100/1000 Ethernet port:
- Use a modular, RJ-45, straight-through UTP cable to connect the MGMT 10/100/1000 Ethernet port to an Ethernet switch port or hub.
  - Use a cross-over cable to connect to a router interface.
- Step 2** Connect the other end of the cable to the device.
- Note** For high availability, connect the MGMT 10/100/1000 Ethernet port on the active Supervisor-1 module and on the standby Supervisor-1 module to the same network or VLAN. The active supervisor module owns the IP address used by both of these Ethernet connections. On a switchover, the newly activated supervisor module takes over this IP address. This process requires an Ethernet connection to the newly activated supervisor module.
-

## Connecting to a Fibre Channel or Fibre Channel over Ethernet (FCoE) Port

The Fibre Channel ports on the switching modules are compatible with LC-type fiber-optic. For information about configuring the switch for in-band management, see the Cisco MDS 9000 Family NX-OS Fundamentals Configuration Guide.

The Cisco MDS 9000 Family supports both Fibre Channel and FCoE protocols for SFP+ and QSFP+ transceivers. Each transceiver must match the transceiver on the other end of the cable, and the cable must not exceed the stipulated cable length for reliable communication. For information on how to get the list of supported SFP+ transceivers for your software release, see the Cisco MDS 9000 Family Release Notes for Cisco MDS NX-OS.



**Warning** Class 1 laser product. Statement 1008



**Warning** Invisible laser radiation may be emitted from disconnected fibers or connectors. Do not stare into beams or view directly with optical instruments. Statement 1051



**Caution** Wear an ESD wrist strap connected to the chassis when handling transceivers. Keep optical connectors covered when not in use, and do not touch connector ends. The fiber-optic connectors must be free of dust, oil, and other contaminants.

This section provides the following topics:

## Removing and Installing SFP+ and QSFP+ Transceivers



**Caution** Removing and installing an SFP+ or QSFP+ transceiver can shorten its useful life. Do not remove and insert SFP+ or QSFP+ transceivers more often than is absolutely necessary. We recommend disconnecting cables before installing or removing these transceivers to prevent damage to the cable or transceiver.



**Note** Use only Cisco SFP+ or QSFP+ transceivers on the Cisco MDS 9700 Series. Each Cisco SFP+ or QSFP+ transceiver is encoded with model information that enables the switch to verify that the SFP+ or QSFP+ transceiver meets the requirements for the switch. For instructions specific to the transceiver type, see the [“SFP+ Transceiver Specifications”](#).

The Cisco MDS 9000 Family supports SFP+ and QSFP+ transceivers with the following two types of latching devices:

- Mylar tab latch

Figure 40: SFP+ Transceiver with Mylar Tab Latch

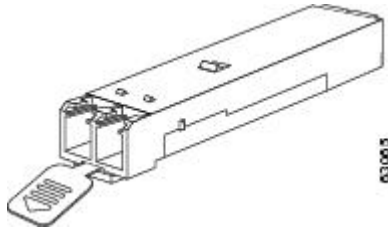

- Bale-clasp latch

Figure 41: SFP+ Transceiver with Bale-Clasp Latch

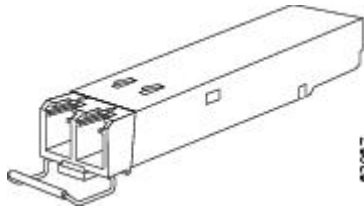

## Removing an SFP+ or QSFP+ Transceiver

To remove an SFP+ or QSFP+ transceiver, follow these steps:

### Procedure

**Step 1** Attach an ESD-preventive wrist strap and follow its instructions for use.

**Step 2** If a cable is installed in the transceiver:

- Record the cable and port connections for later reference.
- Press the release latch on the cable, grasp the connector near the connection point, and gently pull the connector from the transceiver.
- Insert a dust plug into the cable end of the transceiver.

**Caution** If the transceiver does not remove easily in the next step, push the transceiver all the way back in and then ensure that the latch is in the correct position before continuing.

**Step 3** Remove the transceiver from the port:

- If the transceiver has a Mylar tab latch, gently pull the tab straight out (do not twist), and then pull the transceiver out of the port.
- If the transceiver has a bale clasp latch, open the clasp by pressing it downwards, and then pull the transceiver out of the port.

**Note** If you have difficulty removing a bale clasp SFP+ or QSFP+ transceiver, you should reseal the SFP+ or QSFP+ by returning the bale clasp in the up position. Then press the SFP+ or QSFP+ inward and upward into the cage. Next, lower the bale clasp and pull the SFP+ or QSFP+ straight out with a slight upward lifting force (see the following image). Be careful not to damage the port cage during this process.

*Figure 42: Alternate Removal Method for Bale Clasp SFP+ or QSFP+ Transceivers*

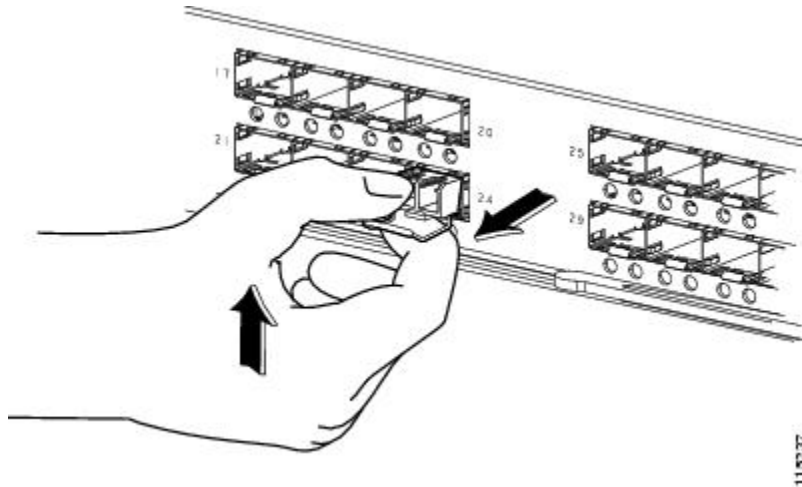

- Step 4** Insert a dust cover into the port end of the transceiver and place the transceiver on an antistatic mat or into a static shielding bag if you plan to return it to the factory.
- Step 5** If another transceiver is not being installed, protect the optical cage by inserting a clean cover.

## Installing an SFP+ Transceiver

To install an SFP+ or QSFP+ transceiver, follow these steps:

### Procedure

- Step 1** Attach an ESD-preventive wrist strap and follow its instructions for use.
- Step 2** Remove the dust cover from the port cage.
- Step 3** Remove the dust cover from the port end of the transceiver.
- Step 4** Insert the transceiver into the port:
- If the transceiver has a Mylar tab, orient the transceiver with the tab on the bottom, and then gently insert the transceiver into the port until it clicks into place.
  - If the transceiver has a bale clasp, orient the transceiver with the clasp on the bottom, close the clasp by pushing it up over the transceiver, and then gently insert the transceiver into the port until it clicks into place.

**Caution** If the transceiver does not install easily, ensure that it is correctly oriented and the tab or clasp are in the correct position before continuing.

**Note** If you cannot install the cable into the transceiver, insert or leave the dust plug in the cable end of the transceiver.

---

## Removing and Installing Cables into SFP+ or QSFP+ Transceivers



**Caution** To prevent damage to the fiber-optic cables, do not place more tension on them than the rated limit and do not bend to a radius of less than 1 inch if there is no tension in the cable, or 2 inches if there is tension in the cable.

---

### Removing a Cable from an SFP+ or QSFP+ Transceiver



**Caution** When pulling a cable from a transceiver, grip the body of the connector. Do not pull on the jacket sleeve, because this can compromise the fiber-optic termination in the connector.

---



**Caution** If the cable does not remove easily, ensure that any latch present on the cable has been released before continuing.

---

To remove the cable, follow these steps:

#### Procedure

---

- Step 1** Attach an ESD-preventive wrist strap and follow its instructions for use.
  - Step 2** Press the release latch on the cable, grasp the connector near the connection point, and gently pull the connector from the transceiver.
  - Step 3** Insert a dust plug into the cable end of the transceiver.
  - Step 4** Insert a dust plug onto the end of the cable.
- 

### Installing a Cable into an SFP+ or QSFP+ Transceiver



**Caution** To prevent possible damage to the cable or transceiver, install the transceiver in the port before installing the cable in the transceiver.

---

To install a cable into a transceiver, follow these steps:

## Procedure

- Step 1** Attach an ESD-preventive wrist strap and follow its instructions for use.
- Step 2** Remove the dust cover from the connector on the cable.
- Step 3** Remove the dust cover from the cable end of the transceiver.
- Step 4** Align the cable connector with the transceiver and insert the connector into the transceiver until it clicks into place (see the following image for reference).

**Figure 43: Connecting the LC-Type Cable to a Fibre Channel Port**

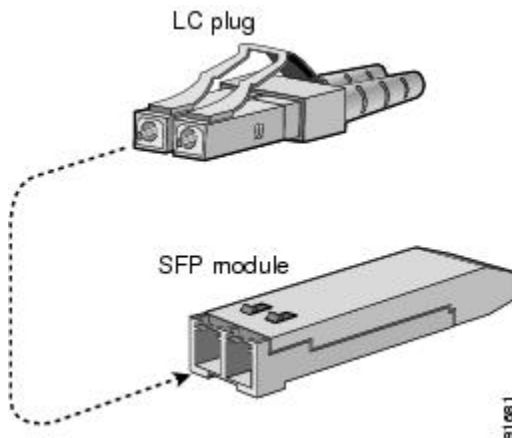

**Caution** If the cable does not install easily, ensure that it is correctly oriented before continuing.

For instructions on verifying connectivity, see the *Cisco MDS 9000 Family NX-OS Fundamentals Configuration Guide*.

## Maintaining SFP+ and QSFP+ Transceivers and Fiber-Optic Cables

SFP+ and QSFP+ transceivers and fiber-optic cables must be kept clean and dust-free to maintain high signal accuracy and prevent damage to the connectors. Attenuation (loss of light) is increased by contamination and should be below 0.35 dB.

Follow these maintenance guidelines:

- SFP+ and QSFP+ transceivers are static sensitive. To prevent ESD damage, wear an ESD-preventive wrist strap that is connected to the chassis.
- Do not remove and insert a transceiver more often than is necessary. Repeated removals and insertions can shorten its useful life.
- Keep all optical connections covered when not in use. If they become dusty, clean before using to prevent dust from scratching the fiber-optic cable ends.

- Do not touch ends of connectors to prevent fingerprints and other contamination.
- Clean regularly; the required frequency of cleaning depends upon the environment. In addition, clean connectors if they are exposed to dust or accidentally touched. Both wet and dry cleaning techniques can be effective; refer to your site's fiber-optic connection cleaning procedure.
- Inspect routinely for dust and damage. If damage is suspected, clean and then inspect fiber ends under a microscope to determine if damage has occurred.







## CHAPTER 6

# Installing, Removing, and Verifying Field Replaceable Units

---

- [Installing a Supervisor Module, on page 115](#)
- [Removing a Supervisor Module, on page 117](#)
- [Installing a Line Card Module, on page 119](#)
- [Removing a Line Card Module, on page 120](#)
- [Upgrading Fibre Channel switching Modules \(Line cards\), on page 122](#)
- [Nondisruptive Migration from Supervisor-1/1E to Supervisor-4 Modules, on page 123](#)
- [Disruptive Migration from Supervisor-1/1E to Supervisor-4 Modules, on page 153](#)
- [Crossbar Fabric Switching Modules, on page 160](#)
- [Nondisruptive Migration from Crossbar Fabric-1 Switching Modules to Crossbar Fabric-3 Switching Modules, on page 166](#)
- [Power Supply in a Switch Chassis, on page 172](#)
- [Installing and Removing Fan Modules or Trays, on page 180](#)
- [Powering up the Switch and Verifying the Component Installation, on page 183](#)

## Installing a Supervisor Module

To install a supervisor module on a Cisco MDS 9700 Series chassis, follow these steps:

### Before you begin

- You must follow the ESD protocols, including the following:
  - You must wear a grounded ESD wristband (or other personal grounding device) whenever you handle the electronic modules outside the grounded chassis.
  - You must carry electronic modules only by their covered edges or handles. Do not touch their electronic components.
  - Whenever a module is outside a grounded chassis, place it flat on an antistatic surface or in an antistatic bag. Never lean the module on anything, or place anything else on top of the module.
- Verify that the chassis is grounded.
- Verify that you have the following tools and equipment:

- ESD wrist strap (or other personal grounding device)
- Number 1 Phillips torque screwdriver
- Manual torque screwdrivers are recommended. Be sure to never exceed the recommended torque setting for the screw that you are working with.
- Replacement supervisor module.

## Procedure

- Step 1** Before installing any modules in the chassis, we recommend that you install the chassis in the rack. See the [Installing the Cisco MDS 9700 Series Switch on a Four-Post Rack or Cabinet](#).
- Step 2** Verify that there is enough clearance to accommodate any cables or interface equipment that you want to connect to the module.
- Step 3** Verify that the captive screws are tightened to 8 in-lb on all modules already installed in the chassis. This ensures that the EMI gaskets are fully compressed and maximizes the opening space for the module being installed.
- Step 4** If a filler panel is installed, remove the Phillips pan-head screw from the filler panel and remove the panel. To remove a currently installed module, see the [Removing a Switching Module](#).
- Step 5** Open the ejector lever on the new or replacement module by pressing on the ejector button. Allow the ejector to open fully (see Callout 1 in the following figure).

**Figure 44: Positioning a Half-width Supervisor Module to its Slot**

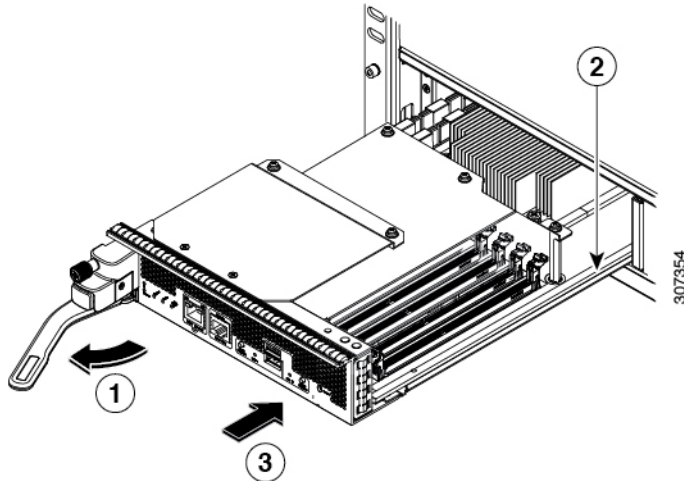

1	Rotate the handle fully away from the front of the module.	3	Push the module all the way into the slot (until it stops and the front is about 1/4 inch in front of the chassis).
2	Align the bottom of the module to the module guides in the slot.		

- Step 6** Rotate the end of the handle away from the front of the module until it stops (see Callout 1 in the previous figure).

**Step 7** With one hand under the supervisor module and the other hand holding the module by its front, align the rear of the module to the open supervisor slot.

**Step 8** Slide the module onto the guides inside the slot and push the module fully into the slot until you cannot push the module further.

The front of the module should be about 1/4 inch (0.6 cm) in front of the chassis.

**Step 9** Rotate the handle to the front of the module (see Callout 1 in the following figure) until it clicks when it reaches the front of the module.

The module should be fully inserted in the slot and the front of the module should be even with the fronts of all the other installed modules. The captive screw by the ejector button on the module should be aligned to a screw hole on the chassis.

**Figure 45: Securing a Supervisor Module to its Slot**

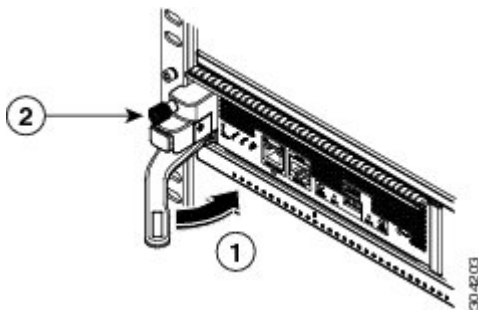

<b>1</b>	Rotate the handle all the way to the front of the module.	<b>2</b>	Tighten the captive screw to 8 in-lb (0.9 N·m) of torque.
----------	---	----------	---

**Step 10** Screw in the captive screw to secure the module to the chassis (see Callout 2 in the previous figure). Tighten the screw to 8 in-lb (0.9 N·m) of torque.

**Step 11** Verify that the supervisor module LEDs turn on and appear as follows:

- STATUS LED is green.
- SYSTEM LED is green.
- ACTIVE LED is amber or green.

**Step 12** Attach the management cable to the MGMT ETH port.

## Removing a Supervisor Module

To remove a supervisor module from the chassis, follow these steps:

**Before you begin**

**Note** You need a flat-blade or number 2 Phillips-head screwdriver to loosen or tighten the captive screws on the supervisor module.

**Procedure**

**Step 1** Failover the standby supervisor if the switch has two supervisor modules and the supervisor you are removing is currently active.

For information on how to failover a supervisor module, see the Cisco MDS 9000 Family NX-OS Fundamentals Configuration Guide.

**Step 2** Put the standby supervisor module to out of service before removing the standby supervisor module, using the **out-of-service module slot** command.

Where *slot* indicates the chassis slot number in which the standby supervisor module resides.

```
switch(config)# out-of-service module 5
```

**Step 3** Disconnect any network interface cables attached to the module.

**Step 4** Unscrew the captive screw on the left side of the module until the screw is no longer connected to the chassis (see Callout 1 in the following figure).

**Figure 46: Removing a Half-width Supervisor Module**

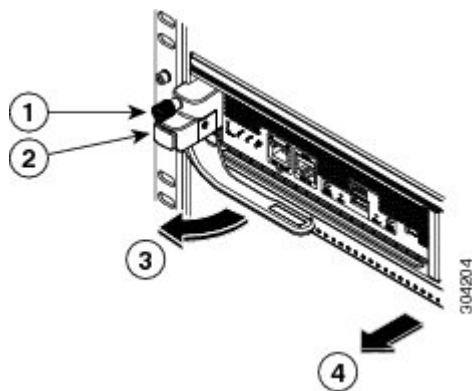

1	Unscrew the captive screw until it is free of the chassis.	3	The handle springs open.
2	Press the ejector button.	4	Pull the handle to remove the module part way from the slot. Place your other hand under the module and fully remove it from the slot.

**Step 5** Press the ejector release button on the left of the module (see Step 2 in the above figure) to push out the ejector lever. The ejector springs out part way from the front of the module.

**Step 6** Fully rotate the handle from the front of the module and pull the handle to move the module part way out of its slot.

- Step 7** Place your other hand under the module to support its weight and pull the module fully out of its slot. Do not touch the module circuitry.
- Step 8** Place the module on an antistatic mat or antistatic foam.
- Step 9** Install a filler panel on an empty slot to keep the chassis dust-free and to maintain proper airflow through the chassis.
- Warning** Blank faceplates and cover panels serve three important functions: they prevent exposure to hazardous voltages and currents inside the chassis; they contain electromagnetic interference (EMI) that might disrupt other equipment; and they direct the flow of cooling air through the chassis. Do not operate the system unless all cards, faceplates, front covers, and rear covers are in place. Statement 1029
- Step 10** Insert a new supervisor module in the empty slot and power on the standby supervisor module. To see how to install a supervisor module, see the [Installing a Supervisor Module, on page 115](#).
- 

## Installing a Line Card Module

### Before you begin

- You must follow the ESD protocols, including the following:
  - You must wear a grounded ESD wristband (or other personal grounding device) whenever you handle the electronic modules outside the grounded chassis.
  - You must carry electronic modules only by their covered edges or handles. Do not touch their electronic components.
  - Whenever a module is outside a grounded chassis, place it flat on an antistatic surface or in an antistatic bag. Never lean the module on anything, or place anything else on top of the module.
- Verify that the chassis is grounded.
- Verify that you have the following tools and equipment:
  - ESD wrist strap (or other personal grounding device)
  - Number 1 Phillips torque screwdriver
- Replacement line card module.



---

**Note** Manual torque screwdrivers are recommended. Be sure to never exceed the recommended torque setting for the screw that you are working with.

---

### Procedure

---

- Step 1** Before installing any modules in the chassis, we recommend that you install the chassis in the rack. See the [Installing the Cisco MDS 9700 Series Switch on a Four-Post Rack or Cabinet](#).

**Step 2** Verify that there is enough clearance to accommodate any cables or interface equipment that you want to connect to the module.

**Step 3** Verify that the captive screws are tightened to 8 in-lb on all modules already installed in the chassis. This ensures that the EMI gaskets are fully compressed and maximizes the opening space for the module being installed.

**Step 4** If a filler panel is installed, remove the Phillips pan-head screw from the filler panel and remove the panel. To remove a currently installed module, see the [Removing a Line Card Module, on page 120](#).

**Note** If you need to remove a blank filler plate from the slot, unscrew the captive screws on either side of the module and pull the handle on the plate to remove it from the slot.

**Step 5** Install the new line card module in a open slot as follows:

a) Unpack the new line card module, set it right side up on an antistatic surface (so that you can see the electrical components from above the module), and inspect the module for damage.

If anything is damaged, contact your customer representative immediately.

b) Press the two eject buttons (one on each side of the module front) and rotate the handles away from the front of the module.

c) Without touching any electronic circuitry, grasp the front of the line card module with one hand, place your other hand under the module to support its weight, and lift the module to the slot.

d) Align the back of the module to the guides inside the slot, and slide the module fully into the slot by pushing on the front of the module.

If you push the module fully into the slot, you seat it onto its connectors inside the slot and the handles move part way toward the front of the module. The front of the module should be 1/4 inch (0.6 cm) out of the slot.

e) Simultaneously rotate each of the two handles to the front of the module until they click.

As you rotate the handles to the front of the module, the module should move fully into the slot.

f) Verify that the front of the module is even with the fronts of the other installed line card modules. If not, press both ejector buttons, pull on the handles to partly remove the module, and repeat Steps 5d and 5e to reseat the module in the slot.

g) Screw in the two captive screws (one on each side of the module) to secure the module to the chassis. Tighten the screws to 8 in-lb (0.9 N·m) of torque.

The Module Status LED should be green. Module status LED will turn green once the module is booted up and operational.

## Removing a Line Card Module

### Before you begin

- You must follow ESD protocols, including the following:
  - You must wear a grounded ESD wristband (or other personal grounding device) whenever you handle the electronic modules outside the grounded chassis.
  - You must carry electronic modules by only their covered edges or handles. Do not touch their electronic components.

- Whenever a module is outside a grounded chassis, place it flat on an antistatic surface or in an antistatic bag. Never lean the module on anything nor place anything else on top of the module nor lean anything on the module.
- Verify that the chassis is grounded.
- Verify that you have the following tools and equipment:
  - Number 1 Phillips torque screwdriver



**Note** Manual torque screwdrivers are recommended. Be sure to never exceed the recommended torque setting for the screw that you are working with.

## Procedure

**Step 1** Put the line card module to out of service before removing it, using the **out-of-service module slot** command.

Where *slot* indicates the chassis slot number in which the standby line card module resides.

```
switch# out-of-service module 5
```

**Step 2** Disconnect all of the cables attached to the front of the line card module to be removed.

**Step 3** Unscrew the captive screw on each side of the module until the screws are loose and no longer connected to the chassis (see Callout 1 in the following figure).

**Figure 47: Removing an line card Module**

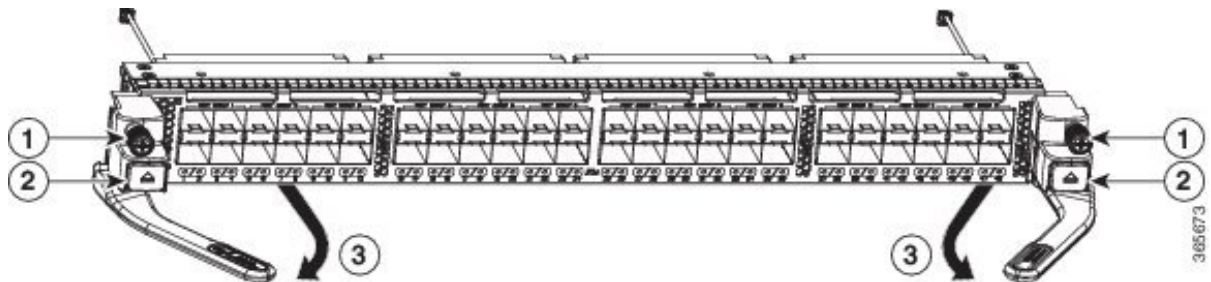

1	Loosen the two captive screws	3	Two handles spring out part way from the front of the module
2	Press the two ejector buttons		

**Step 4** Press the two ejector buttons on the each side of the module (see Callout 2 in the above figure).

The two handles spring out part way from the front of the module.

**Step 5** Fully rotate the two handles away from the front of the module and pull on them to move the module part way out of its slot.

**Step 6** Place one hand under the module to support its weight, grasp the front of the module with the other hand, pull the module fully out of its slot, and set the module on an antistatic surface.

**Caution** Do not touch any electrical circuitry on the removed line card module. Handle the module only by its covered surfaces (front and bottom of the module) and always set the module on an antistatic surface when it is not inside the chassis.

**Step 7** Install a filler panel on an empty slot to keep the chassis dust-free and to maintain proper airflow through the chassis.

**Warning** Blank faceplates and cover panels serve three important functions: they prevent exposure to hazardous voltages and currents inside the chassis; they contain electromagnetic interference (EMI) that might disrupt other equipment; and they direct the flow of cooling air through the chassis. Do not operate the system unless all cards, faceplates, front covers, and rear covers are in place. Statement 1029

**Step 8** Insert a new line card module in the empty slot and power on the line card module. To see how to install a line card module, see the [Installing a Line Card Module, on page 119](#).

## Upgrading Fibre Channel switching Modules (Line cards)

You can migrate the line card configuration of one type of line card to another type of line card. This enables no loss of line card configurations while upgrading line card models.



- Note**
- Ensure the line cards are FC line cards with the same number of ports. For example, replace an old 16G 48 port line card with a new 32G 48 port line card.
  - Few of the configurations migrated are VSAN on ports, port descriptions, buffer credits, port speed and so on.

### Procedure

**Step 1** `switch# migrate configuration linecard module`

Displays the valid linecard modules

```
migrate configuration linecard
```

Valid modules are as shown below

```
+-----+-----+-----+-----+-----+
| Mod | Ports | Module-Type | Model | Status |
+-----+-----+-----+-----+-----+
| 1 | 48 | 2/4/8/10/16 Gbps Advanced FC Module | DS-X9448-768K9 | ok |
| 5 | 48 | 2/4/8/10/16 Gbps Advanced FC Module | DS-X9448-768K9 | ok |
+-----+-----+-----+-----+-----+
```

**Step 2** Enter the module number for the migrated or replaced linecard and press Enter.

```
Enter module number which needs to be migrated/replaced: 1
```



```
Collecting configuration details of module 1 (DS-X9448-768K9). Please wait...

Successfully collected the configuration details of module 1 (DS-X9448-768K9) in file
bootflash:module_config.cfg.
```

**Step 3** Remove the switching module and replace with a new switching module and press Enter.

```
Remove module 1 (DS-X9448-768K9) , replace it with the new module and press enter
```

**Step 4** Type y to confirm the replacement of the new switching module and press Enter.

```
Have you inserted the new module in slot 1? (y/n): y
```

```
Booting up the new module in slot 1 . Please wait...
```

```
The new module in slot 1 (DS-X9648-1536K9) is up.
Applying the configs to the new module. Please wait..
```

```
Successfully applied the config bootflash:module_config.cfg to running config.
```

```
Elapsed time: 0 hours, 3 minutes, 55 seconds
```

---

## Nondisruptive Migration from Supervisor-1/1E to Supervisor-4 Modules

This topic describes the steps that are required to migrate both Supervisor-1 Modules (DS-X97-SF1-K9) to Supervisor-4 Modules (DS-X97-SF4-K9) for the Cisco MDS Multilayer Director 9706 or 9710, and Supervisor-1E Modules (DS-X97-SF1E-K9) to Supervisor-4 Modules (DS-X97-SF4-K9) for the Cisco MDS 9718 Multilayer Director.

This topic includes the following sections:



---

**Note** Before you install, operate, or service the system, read the *Regulatory Compliance and Safety Information for the Cisco MDS 9000 Family* for important safety information.

---



---

**Warning** **IMPORTANT SAFETY INSTRUCTIONS**

This warning symbol indicates danger. You are in a situation that could cause physical injury. Before you work on any equipment, be aware of the hazards that are involved with electrical circuitry and be familiar with standard practices for preventing accidents. Use the statement number provided at the end of each warning to locate its translation in the translated safety warnings that accompanied this device. Statement 1071

SAVE THESE INSTRUCTIONS

---



---

**Warning** This unit is intended for an installation in restricted access areas. A restricted access area can be accessed only through the use of a special tool, lock and key, or other means of security. Statement 1017

---



---

**Warning** Only trained and qualified personnel should be allowed to install, replace, or service this equipment. Statement 1030

---



---

**Warning** A readily accessible two-poled disconnect device must be incorporated in the fixed wiring. Statement 1022

---



---

**Warning** Ensure that there is no loose debris (such as paper, ties, dust) around the back of the chassis since when the crossbar switching modules are being removed. The vacuum created can be strong enough to pull the loose debris into the chassis.

---

## Requirements

We recommend that you have knowledge of the Cisco NX-OS operating system CLI.

## Components Used

The information in this document is applies to the following hardware components:

- Cisco MDS 9718 Multilayer Director (DS-C9718)
- Cisco MDS 9710 Multilayer Director (DS-C9710)
- Cisco MDS 9706 Multilayer Director (DS-C9706)
- Cisco MDS 9700 Series Supervisor-4 Module (DS-X97-SF4-K9)
- Cisco MDS 9700 Series Supervisor-1E Module (DS-X97-SF1E-K9)
- Cisco MDS 9700 Series Supervisor-1 Module (DS-X97-SF1-K9)

## Guidelines and Limitations

Guidelines and limitations for a nondisruptive migration of both the supervisor modules (Active and Standby) to Supervisor-4 Modules (DS-X97-SF4-K9):

- Ensure that the Supervisor-4 Module is not inserted in the standby slot before initiating the supervisor migration command. If the Supervisor-4 Module is already inserted in the standby slot, the migration procedure will be aborted and the Supervisor-4 Module will be powered down.
- Insert the standby Supervisor-4 Module into the chassis only when you are prompted to insert the Supervisor-4 Module during the migration by a message on the system console.
- After the Supervisor-4 Module has been inserted during the migration procedure, do not remove or manually reload the standby Supervisor-4 Module.

- Back up all the licenses before starting the migration procedure. After the migration procedure is completed, licenses have to be applied or installed again. For more information on how to back up the licenses, see the “Prerequisites” section.
- Back up the switch configuration and all important bootflash files on both the supervisor modules before starting the migration procedure. In case of any failure or loss of configuration in the Supervisor-4 Module, disruptive migration has to be done to upgrade to Supervisor-4 Module. In such a scenario, the entire switch configuration has to be applied again. For more information on how to back up the switch configurations, see the “Prerequisites” section.
- Use the **show environment power** command to display the actual power usage information for the entire switch.
- Ensure that the running Supervisor-1/1E Cisco MDS NX-OS and the target Supervisor-4 Cisco MDS NX-OS release versions used in the supervisor migration command are the same. Use the **show version** command to view the version of the Cisco MDS NX-OS software running on the switch.
- The supervisor migration command is supported on Cisco MDS NX-OS Release 8.4(1) or later on Cisco MDS 9710 and Cisco MDS 9706 Director switches. On Cisco MDS 9718 Director switch, the migration command is supported from Cisco MDS NX-OS Release 8.4(2a) or later. **Invalid command** message is displayed, if this command is executed on the other versions of the Cisco MDS NX-OS release. Initiate the migration process on the active supervisor-1 module using the following command in exec mode.

**Table 19: Migration command**

Release	Command
MDS 9706 and MDS 9710NX-OS releases 8.4(1) to 9.4(1)	Configuration mode: <b>migrate sup kickstart supervisor4-kickstart-image system supervisor4-system-image</b>
MDS 9718 8.4(2a) to 9.4(1)	Configuration mode: <b>migrate sup kickstart supervisor4-kickstart-image system supervisor4-system-image</b>
MDS 9706 MDS 9710 MDS 9718NX-OS release 9.4(2a) and later	Exec mode: <b>migrate hardware sup kickstart supervisor4-kickstart-image system supervisor4-system-image</b>

- The migration procedure must be performed during a schedule maintenance period only.
- Nondisruptive backward migration (migrating from a Supervisor-4 Module to a Supervisor-1E or Supervisor-1 Module) is not supported. Backward migration is disruptive (this requires powering off and then powering on the switch).
- After the migration procedure, the current active supervisor module will be in standby state and the current standby supervisor module will be in active state.
- Do not reload or manually insert or remove any I/O or crossbar fabric switching modules after initiating the supervisor migration command. Any removal or insertion of I/O or Crossbar Fabric-1 Switching Modules must be done before initiating the migration procedure or after the migration is completed.

- Perform the Fabric-1 to Fabric-3 module migration immediately after the Supervisor-1/Supervisor-1E to Supervisor-4 Module migration is completed. A mix of Fabric-1 with Supervisor-4 Modules or Fabric-3 with Supervisor-1/Supervisor-1E Modules is not supported.
- Configuration mode is blocked during the migration procedure to prevent any changes from affecting the migration process..
- You can use **Control+C** to cancel the migration procedure but only after 45 minutes have elapsed after executing the supervisor migration command.
- Use the **show logging onboard migration status** command on any management session to display the status of the migration. You can use this command during the migration or after the migration is complete.
- In the system messages (system messages displayed on the console during the migration procedure) and the **show module** command output, Supervisor-1 Module (DS-X97-SF1-K9) and Supervisor-1E Module (DS-X97-SF1E-K9) are displayed as *Supervisor-3 Module*.
- If you are using a Supervisor-4 Module for migration that has been already used in a previous MDS chassis ensure that the Supervisor-4 module has sufficient space on bootflash for copying both the system and kickstart images before the migration.
- The following table lists the supported combinations for supervisor modules with crossbar fabric modules on the Cisco MDS 9700 Series of Multilayer Directors in a production environment.

In the following table:

- The term, “Yes” indicates the supported combinations.
- The “—” symbol indicates the unsupported combinations.

Combination	Supervisor-1 Module	Supervisor-1E Module	Supervisor-4 Module	Crossbar Fabric-1 Switching Module	Crossbar Fabric-3 Switching Module
Supervisor-1 Module	Yes	—	—	Yes	—
Supervisor-1E Module	—	Yes	—	Yes	—
Supervisor-4 Module	—	—	Yes	—	Yes
Crossbar Fabric-1 Switching Module	Yes	Yes	—	Yes	—
Crossbar Fabric-3 Switching Module	—	—	Yes	—	Yes

## Prerequisites

- Ensure that you have network-admin role privileges to migrate the supervisor modules.

```
switch# show user-account admin
user:admin
this user account has no expiry date
roles:network-admin
```

- Ensure the switch is running a release that support supervisor migration.

The following table lists the supported release versions for migrating to Supervisor-4 Modules on the Cisco MDS 9700 Series of Multilayer Directors.

Product Name	Supported MDS NX-OS Release Versions
Cisco MDS 9718 Director	Cisco MDS NX-OS Release 8.4(2a) and later
Cisco MDS 9710 Director	Cisco MDS NX-OS Release 8.4(1) and later
Cisco MDS 9706 Director	Cisco MDS NX-OS Release 8.4(1) and later

To upgrade an image version on the switch, refer the [Cisco MDS 9000 NX-OS Software Upgrade and Downgrade Guide, Release 8.x](#) guide.

- If it is planned to upgrade the Cisco MDS NX-OS version from the current version then upgrade Cisco MDS NX-OS and then execute the supervisor migration.
- During the Supervisor-1 to Supervisor-4 Module migration procedure, do not:
  - insert or remove any transceivers from any modules.
  - alter any connections.
  - remove any power supply modules or fan modules.
  - attempt any configuration changes or network changes.
  - copy any configuration using the **copy running-config startup-config** command.
  - overlap with any EPLD or BIOS upgrades.
  - trigger any ISSU.
- We recommend that you use a console connection to perform the migration procedure. In case you do not have a console connection and are using an SSH/Telnet connection, use the **terminal monitor** command to display the syslogs mentioned in the below procedures.
- Back up the running configuration from the current active supervisor module (DS-X97-SF1-K9) to an FTP, SFTP, TFTP, SCP server, or a USB flash drive.

```
switch# copy running-config sftp://192.0.2.1/$(SWITCHNAME)_runningconfiguration.txt
Enter username: test
Connected to 192.0.2.1.
Uploading /var/tmp/vsh/switch-running-config to /runningconfiguration.txt
Copy complete.
```

```
switch(config)# copy running-config usb1:runningconfiguration.txt
Copy complete, now saving to disk (please wait)..
```



**Note** runningconfiguration.txt is a filename.

**\$(SWITCHNAME)** adds the switch's switchname to the filename.

- Back up any important files from the bootflash of the current active and standby supervisor modules (DS-X97-SF1-K9) to an FTP, SFTP, TFTP, SCP server, or a USB flash drive.

```
switch# copy bootflash:userfile.txt scp://test@192.0.2.1/test/$(SWITCHNAME)_userfile.txt
```



**Note** `userfile.txt` is a filename.

`$(SWITCHNAME)` adds the switch's switchname to the filename.

- Back up the installed licenses from the switch to an FTP, SFTP, TFTP, SCP server or USB drive by using the **copy licenses** command. To view the current licenses installed on the switch, use the **show license** command.

```
switch# show license

license.lic:
SERVER this_host ANY
VENDOR cisco
INCREMENT ENTERPRISE_PKG cisco 1.0 permanent uncounted \
VENDOR_STRING=MDS HOSTID=VDH=REG070201 \
NOTICE="<LicFileID>ent_ips_main_fm.lic</LicFileID><LicLineID>0</LicLineID> \
<PAK>dummyPak</PAK>" SIGN=FB454F0A0D40
INCREMENT MAINFRAME_PKG cisco 1.0 permanent uncounted \
VENDOR_STRING=MDS HOSTID=VDH=REG070201 \
NOTICE="<LicFileID>ent_ips_main_fm.lic</LicFileID><LicLineID>1</LicLineID> \
<PAK>dummyPak</PAK>" SIGN=0DAE1B086D9E
INCREMENT SAN_EXTN_OVER_IP cisco 1.0 permanent 7 VENDOR_STRING=MDS \
HOSTID=VDH=REG070201 \
NOTICE="<LicFileID>ent_ips_main_fm.lic</LicFileID><LicLineID>2</LicLineID> \
<PAK>dummyPak</PAK>" SIGN=D336330C76A6
INCREMENT FM_SERVER_PKG cisco 1.0 permanent uncounted \
VENDOR_STRING=MDS HOSTID=VDH=REG070201 \
NOTICE="<LicFileID>ent_ips_main_fm.lic</LicFileID><LicLineID>3</LicLineID> \
<PAK>dummyPak</PAK>" SIGN=AEAEA04629E8

switch# copy licenses usb1:licenses_archive_file_name.tar
```



**Note** You must use the tar extension for the archive file. This file contains all the license files that are installed on the Supervisor-1 Module.

- Back up the output of the **show tech-support details** command to a remote server using an FTP, TFTP, SFTP, SCP server, or a USB flash drive.

```
switch# show tech-support details >
scp://test@192.0.2.1/test/$(SWITCHNAME)_showtechsupport.txt
```

or

```
switch# show tech-support details > usb1:$(SWITCHNAME)_showtechsupport.txt
```

`$(SWITCHNAME)` adds the switch's switchname to the filename.

- Ensure the following parts are available
  - Supervisor-4 Module (DS-X97-SF4-K9). Two Supervisor-4 Modules for the dual supervisor migration.

- Ensure the switch is running a recommended code release before proceeding with the hardware upgrade. For the list of recommended releases, see [Recommended Releases for Cisco MDS 9000 Series Switches](#).

## Nondisruptive Supervisor-4 Migration on Dual Supervisor Switch

To perform a nondisruptive migration from both Supervisor-1/Supervisor-1E Modules to Supervisor-4 Modules in a switch that has both the Active and Standby supervisor modules installed, follow these steps:

Before starting the migration procedure in a dual supervisor module scenario, ensure that the standby supervisor module is in the HA-standby state. If the standby supervisor does not come up in the HA-standby state then physically remove the standby supervisor module and initiate the migration on the active supervisor module. Use the **show module** command to view the state of the supervisor modules.



**Note** In the following procedure, all show outputs, system messages, and image file names are displayed for the Cisco MDS 9710 Multilayer Director Switch. The show outputs, system messages, and image file names will vary based on the Cisco MDS 9700 Series Multilayer Director Switch being upgraded.

### Procedure

#### Step 1

Log in to the switch and use the **show module** command to view the Active and Standby supervisor modules.

In this procedure, Cisco MDS 9710 chassis is used and the active supervisor module is in slot 6, and the standby supervisor module is in slot 5. The migration command is executed on the active supervisor.

**Note** In the following **show module** command output, Supervisor-1 Module (DS-X97-SF1-K9) is listed as Supervisor Module-3.

```
switch# show module
```

Mod	Ports	Module-Type	Model	Status
1	48	1/10 Gbps Ethernet Module	DS-X9848-480K9	ok
2	48	2/4/8/10/16 Gbps Advanced FC Module	DS-X9448-768K9	ok
3	24	40 Gbps FCoE Module	DS-X9824-960K9	ok
4	48	4/8/16/32 Gbps Advanced FC Module	DS-X9648-1536K9	ok
5	0	Supervisor Module-3	DS-X97-SF1-K9	ha-standby
6	0	Supervisor Module-3	DS-X97-SF1-K9	active *
7	34	1/10/40G IPS, 2/4/8/10/16G FC Module	DS-X9334-K9	ok
8	48	4/8/16/32 Gbps Advanced FC Module	DS-X9648-1536K9	ok
10	48	2/4/8/10/16 Gbps Advanced FC Module	DS-X9448-768K9	ok

Mod	Sw	Hw
1	8.4(1)	1.1
2	8.4(1)	1.3
3	8.4(1)	1.0
4	8.4(1)	1.0

```
...
```

Xbar	Ports	Module-Type	Model	Status
1	0	Fabric Module 1	DS-X9710-FAB1	ok
2	0	Fabric Module 1	DS-X9710-FAB1	ok
3	0	Fabric Module 1	DS-X9710-FAB1	ok

## Nondisruptive Supervisor-4 Migration on Dual Supervisor Switch

```

4    0    Fabric Module 1          DS-X9710-FAB1    ok
5    0    Fabric Module 1          DS-X9710-FAB1    ok
6    0    Fabric Module 1          DS-X9710-FAB1    ok

```

...

**Step 2** Ensure that the required space is available in the bootflash: directory for the Supervisor-4 image files to be copied using the **dir bootflash:** command. Use the **delete bootflash:filename** command to remove individual files.

**Step 3** Copy the Supervisor-4 Module Cisco NX-OS kickstart and system images to the active Supervisor-1 Module bootflash, using an FTP, TFTP, SCP, SFTP server, or a USB flash drive.

**Note** Ensure that the running Supervisor-1 Cisco MDS NX-OS and the target Supervisor-4 Cisco MDS NX-OS release versions are the same. Use the show version command to view the version of the Cisco MDS NX-OS software running on the switch.

**Note** The running Supervisor-1 Cisco MDS NX-OS release version and the target Supervisor-4 Cisco MDS NX-OS release version must be same. If there is a mismatch in the release versions, the following error message is displayed:

The Supervisor-4 images contain the string **sf4** to identify them. Do not rename the images; use the standard image names.

```

switch# copy tftp://tftpserver.example.com/MDS/m9700-sf4ek9-kickstart-mz.8.4.1.bin
bootflash:m9700-sf4ek9-kickstart-mz.8.4.1.bin
switch# copy tftp://tftpserver.example.com/MDS/m9700-sf4ek9-mz.8.4.1.bin
bootflash:m9700-sf4ek9-mz.8.4.1.bin

```

**Step 4** Verify the images by using the below commands:

The following example shows the MD5 checksum value of the image, which can be compared with the MD5 checksum value listed on the software download page

```

switch# show file m9700-sf4ek9-kickstart-mz.8.4.1.bin md5sum
c41f7bd29b561610d766c89e12851a4f

switch# show file m9700-sf4ek9-mz.8.4.1.bin md5sum
28f65c79ba6bc9418960b384cdab2fb7

```

The following example confirms that the MD5 verification was successful.

```

switch# show version image m9700-sf4ek9-kickstart-mz.8.4.1.bin
MD5 Verification Passed
  image name: m9700-sf4ek9-kickstart-mz.8.4.1.bin
  kickstart:  version 8.4(1)
  compiled:    6/30/2019 23:00:00 [06/15/2019 05:19:08]

switch# show version image m9700-sf4ek9-mz.8.4.1.bin
MD5 Verification Passed
  image name: m9700-sf4ek9-mz.8.4.1.bin
  bios:      v2.6.0 (05/17/2019)
  system:    version 8.4(1)
  compiled:  6/30/2019 23:00:00 [06/15/2019 06:45:18]

```

**Step 5** If you are not logged in to the switch on the console port, then enable syslog monitoring by using the **terminal monitor** command.

```
switch# terminal monitor
```

**Step 6** Initiate the migration process on the active Supervisor-1 module using the release-dependent supervisor migration command. For more information, see refer to [Guidelines and Limitations](#) section above.

```
switch# configure terminal
```



**Step 7** Execute the supervisor migration command:

```
switch# configure terminal
switch(config)# migrate sup kickstart m9700-sf4ek9-kickstart-mz.8.4.1.bin
system m9700-sf4ek9-mz.8.4.1.bin
Kickstart image file is /bootflash/m9700-sf4ek9-kickstart-mz.8.4.1.bin
System image file is /bootflash/m9700-sf4ek9-kickstart-mz.8.4.1.bin

ERROR!!! Running system version: 8.4(1), version of system image provided:8.4(2b) <Fri Oct 23
16:08:44 2020> ERROR!!! Version of system image provided('m9700-sf4ek9-mz.8.4.2b.bin') does not
match running version, aborting migration.
```

**Step 8** During the migration, enter “y” when prompted to do so.

**Note** After this point, the migration process will be locked and you cannot cancel the migration process. The migration command checks if it has to initiate a single supervisor or dual supervisor migration process by checking if there is a standby Supervisor-1 Module installed in the switch.

**Note** In the following system message, Supervisor-1 Module (DS-X97-SF1-K9) is listed as Supervisor-3.

This will start the Supervisor-3 to Supervisor-4 migration. Configuration will be locked until migration is complete.

Do you wish to continue (y/n) [n] y

The following messages are displayed:

```
<Tue Jun 25 15:06:56 2019> Starting migration, Please do not remove any linecards or fabric cards
until migration is complete
2019 Jun 25 15:06:56 switch %PLATFORM-2-MOD_PWRDN: Module 5 powered down (Serial number JAE194005JC)
2019 Jun 25 15:06:56 switch %PLATFORM-5-MOD_STATUS: Module 5 current-status is
MOD_STATUS_CONFIGPOWERED_DOWN
2019 Jun 25 15:06:56 switch %PLATFORM-5-MOD_STATUS: Module 5 current-status is MOD_STATUS_POWERED_DOWN
```

**Step 9** The standby Supervisor-1 Module will be powered down and its Status LED will be blinking red. Use the **show module** command to display the status of the modules installed in the switch.

```
switch# show module
Mod  Ports  Module-Type                Model                Status
---  ---
1    48     1/10 Gbps Ethernet Module  DS-X9848-480K9      ok
2    48     2/4/8/10/16 Gbps Advanced FC Module DS-X9448-768K9      ok
3    24     40 Gbps FCoE Module        DS-X9824-960K9      ok
4    48     4/8/16/32 Gbps Advanced FC Module DS-X9648-1536K9     ok
5    0      Supervisor Module-3        DS-X97-SF1-K9       powered-dn
6    0      Supervisor Module-3        DS-X97-SF1-K9       active *
7    34     1/10/40G IPS,2/4/8/10/16G FC Module DS-X9334-K9         ok
8    48     4/8/16/32 Gbps Advanced FC Module DS-X9648-1536K9     ok
10   48     2/4/8/10/16 Gbps Advanced FC Module DS-X9448-768K9      ok

Mod  Power-Status  Reason
---  ---
5    powered-dn    Out of service
...
```

If the standby Supervisor-1 Module is not in the **powered-dn** state, then manually power it down with the **out-of-service module slot** command where *slot* indicates the chassis slot number in which the standby supervisor module is located.

```
switch(config)# out-of-service module 6
```

If the **out-of-service module** command fails then check the migration status using the **show logging onboard migration status** command on any management session.

**Step 10**

After the standby supervisor module is powered down, replace a supervisor module with the new Supervisor-4 Module, as explained in the “[Removing a Supervisor Module](#)” section and the “[Installing a Supervisor Module](#)” section. When the Supervisor-4 Module is detected in the standby supervisor slot, it is booted with the NX-OS software specified in the migration command.

```
<Tue Jun 25 15:06:57 2019> Manual-boot is enabled for Standby Supervisor
<Tue Jun 25 15:06:57 2019> Please remove Supervisor-3 (DS-X97-SF1-K9) module from slot 5 and insert
  Supervisor-4 (DS-X97-SF4-K9) module within 30 minutes
2019 Jun 25 15:06:57 switch %PLATFORM-2-MOD_REMOVE: Module 5 removed (Serial number JAE194005JC)

2019 Jun 25 15:07:33 switch %PLATFORM-2-SINGLE_EJECTOR_STAT_CHANGED: Ejector's status in slot 5 has
  changed, Ejector is OPEN
2019 Jun 25 15:07:34 switch %PLATFORM-2-MOD_REMOVE: Module 5 removed (Serial number JAE194005JC)
```

**Note** Insert the Supervisor-4 Module into the switch within a period of 30 minutes after initiating the migration command. If the Supervisor-4 Module is not inserted within 30 minutes after executing the migration command the standby Supervisor-1 will be powered up again, if present, and the migration aborted. Perform [Step 4](#) to [Step 6](#) again and continue the migration process.

Once the supervisor module is physically replaced, the following syslog messages are displayed on the active

Supervisor-1 Module:

```
2019 Jun 25 15:07:57 switch %PLATFORM-2-MODULE_EJECTOR_POLICY_ENABLED: All Ejectors closed for
  module 5. Ejector based shutdown enabled
2019 Jun 25 15:07:57 switch %PLATFORM-2-MOD_DETECT: Module 5 detected (Serial number :unavailable)
  Module-Type Supervisor Module-4 Model :unavailable
<Tue Jun 25 15:08:07 2019> Supervisor-4 (DS-X97-SF4-K9) is detected in slot 5
<Tue Jun 25 15:08:12 2019> Reloading standby. This might take up to 15 minutes. Please wait...
2019 Jun 25 15:08:13 sw9710-SUP3-101 %PLATFORM-2-PFM_STANDBY_MODULE_RESET_MIGRATION: Reloading
  Standby Supervisor as part of Supervisor migration
```

**Step 11**

Wait for approximately 20 minutes for the new Supervisor-4 Module to come up in the HA-standby state.

The following messages are displayed on the active Supervisor-1 Module:

```
<Tue Jun 25 15:10:13 2019> Standby supervisor not yet online. This might take some time, Please
  wait...
<Tue Jun 25 15:12:13 2019> Standby supervisor not yet online. This might take some time, Please
  wait...
2019 Jun 25 15:12:18 switch %SYSMGR-2-ACTIVE_LOWER_MEM_THAN_STANDBY: Active supervisor in slot 6
  is running with less memory than standby supervisor in slot 5.
2019 Jun 25 15:12:27 switch %USBHSD-STANDBY-2-MOUNT: logflash: online
2019 Jun 25 15:12:27 switch %USBHSD-STANDBY-2-MOUNT: USB1: online
2019 Jun 25 15:12:32 switch %BOOTVAR-5-NEIGHBOR_UPDATE_AUTOCOPY: auto-copy supported by neighbor
  supervisor, starting...
2019 Jun 25 15:14:05 switch %PLATFORM-1-PFM_ALERT: Disabling ejector based shutdown on sup in slot
  5
<Tue Jun 25 15:14:13 2019> Standby supervisor not yet online. This might take some time, Please
  wait...
```

**Note** If you see the following failure message, ignore it as, the active Supervisor-1 Module will pause the standby Supervisor-4 Module initialization process for a while and then automatically restart the standby initialization process.

```
Tue Jun 25 15:14:13 2019 switch %SYSMGR-2-STANDBY_BOOT_FAILED: Standby supervisor failed to boot
  up.
```

**Note** After the Supervisor-4 Module is inserted in the standby supervisor slot, a timer is started for the Supervisor-4 Module to power up and come online. If the Supervisor-4 Module fails to power up and come online at the first attempt, a retry is initiated every 15 minutes. If the Supervisor-4 Module fails to come online after three retries or 45 minutes, you have to remove the Supervisor-4 Module and restart the migration process.

The following messages are displayed when the standby module (Supervisor-4 Module in slot 5) is online:

```
2019 Jun 25 15:15:06 switch %MODULE-5-STANDBY_SUP_OK: Supervisor 5 is standby
2019 Jun 25 15:15:07 switch %PLATFORM-1-PFM_ALERT: Enabling ejector based shutdown on sup in slot
6
<Tue Jun 25 15:15:33 2019> Standby Supervisor-4 (DS-X97-SF4-K9) has come online, configs will be
copied
```

**Step 12** The current configuration will be synchronized to the new standby supervisor by automatically executing **copy running-config startup-config**. After this a supervisor switchover is initiated. Any SSH/Telnet sessions to the switch will be terminated at this point.

The following messages are displayed:

```
<Tue Jun 25 15:15:33 2019> Saving configuration now. Please wait...
[#####] 100%
Copy complete.
/mnt/plog/migration.log: 2.78 kB 71.36 kB/s
<Tue Jun 25 15:15:46 2019> Supervisor-3 (DS-X97-SF1-K9) will switchover to Supervisor-4
(DS-X97-SF4-K9) now
<Tue Jun 25 15:15:46 2019> Switchover is successful, Supervisor-4 (DS-X97-SF4-K9) is now active
```

**Step 13** The supervisor switchover changes the new Supervisor-4 Module from HA standby to Active state. If using SSH/Telnet reconnect several seconds after the switchover. Ensure that the console link and the management link are connected to the Supervisor-4 Module.

The following syslog messages are displayed on the active Supervisor-4 Module:

```
switch(standby) login: 2019 Jun 25 15:15:47 switch %KERN-2-SYSTEM_MSG: [ 377.107557] Switchover
started by redundancy driver - kernel
2019 Jun 25 15:15:47 switch %SYSMGR-2-HASWITCHOVER_PRE_START: This supervisor is becoming active
(pre-start phase).

2019 Jun 25 15:15:47 switch %SYSMGR-2-HASWITCHOVER_START: Supervisor 5 is becoming active.
User Access Verification
switch login: 2019 Jun 25 15:15:48 switch %SYSMGR-2-SWITCHOVER_OVER: Switchover completed.
2019 Jun 25 15:15:48 switch %ASCII-CFG-6-INFORMATION: Reading ACFG Runtime information
2019 Jun 25 15:15:48 switch %IM-5-IM_MGMT_INTF_STATE: mgmt0 is DOWN
2019 Jun 25 15:15:48 switch %FC-REDIRECT-5-IVR_SUPPORT_ENABLED: IVR Support Enabled in FC_Redirect.
Source: Local Switch - 20:00:84:78:ac:09:35:00
2019 Jun 25 15:15:50 switch %PLATFORM-1-PFM_ALERT: Disabling ejector based shutdown on sup in slot
5
2019 Jun 25 15:15:52 switch %BOOTVAR-2-SUP_MIGRATION_CONFIG_STARTED: Setting boot parameters for
supervisor migration process. It might take some time. Please do not set any config parameters
during this time or do not replace standby.
2019 Jun 25 15:15:56 switch %IM-5-IM_MGMT_INTF_STATE: mgmt0 is UP
```

**Step 14** After the switchover to the first Supervisor-4 Module is completed, the following messages are displayed:

```
User Access Verification
switch login: 2019 Jun 25 15:16:39 switch %BOOTVAR-2-SUP_MIGRATION_CONFIG_COMPLETE: Migration process
is complete now. Supervisor-3 (DS-X97-SF1-K9) in standby slot can now be replaced with Supervisor-4
(DS-X97-SF4-K9).
2019 Jun 25 15:18:00 switch %SYSMGR-2-SBY_SUP_LESS_MEMORY_SLOT: Supervisor in slot 6 is running
with less memory than active supervisor in slot 5
2019 Jun 25 15:18:00 switch %SYSMGR-2-CONVERT_STARTUP_ABORTED: Conversion of startup-config failed.
2019 Jun 25 15:18:00 switch %PLATFORM-2-MOD_PWRDN: Module 6 powered down (Serial number JAE17440HVB)
2019 Jun 25 15:18:00 switch %PLATFORM-5-MOD_STATUS: Module 6 current-status is
MOD_STATUS_CONFIGPOWERED_DOWN
2019 Jun 25 15:18:00 switch %PLATFORM-5-MOD_STATUS: Module 6 current-status is MOD_STATUS_POWERED_DOWN
2019 Jun 25 15:18:00 switch %PLATFORM-2-MOD_REMOVE: Module 6 removed (Serial number JAE17440HVB)
```

```
2019 Jun 25 15:18:0 switch %BOOTVAR-2-SUP_MIGRATION_CONFIG_COMPLETE:
Migration process is complete now.
Supervisor-3 (DS-X97-SF1-K9) in standby slot can now be replaced with Supervisor-4 (DS-X97-SF4-K9).
```

**Warning** A mix of different Supervisor-4 Modules and Supervisor-1/Supervisor 1E Modules outside a migration process is not supported. This mix of modules is supported only while you are migrating from a Supervisor-1/Supervisor 1E Module to a Supervisor-4 Module.

Use the **show boot** command to display the current boot variables.

```
switch# show boot
kickstart variable = bootflash:/m9700-sf4ek9-kickstart-mz.8.4.1.bin
system variable = bootflash:/m9700-sf4ek9-mz.8.4.1.bin
Boot POAP Disabled
```

### Step 15

The old active Supervisor-1 Module will be powered down and its Status LED will be blinking red. Use the **show module** command to display the status of the modules installed in the switch.

```
switch# show module
Mod  Ports  Module-Type                Model                Status
---  ---
1    48     1/10 Gbps Ethernet Module  DS-X9848-480K9      ok
2    48     2/4/8/10/16 Gbps Advanced FC Module DS-X9448-768K9      ok
3    24     40 Gbps FCoE Module        DS-X9824-960K9      ok
4    48     4/8/16/32 Gbps Advanced FC Module DS-X9648-1536K9     ok
5    0      Supervisor Module-4        DS-X97-SF4-K9       active *
6    0      Supervisor Module-3        DS-X97-SF1-K9       powered-dn
7    34     1/10/40G IPS,2/4/8/10/16G FC Module DS-X9334-K9         ok
8    48     4/8/16/32 Gbps Advanced FC Module DS-X9648-1536K9     ok
10   48     2/4/8/10/16 Gbps Advanced FC Module DS-X9448-768K9      ok

Mod  Power-Status  Reason
---  -
6    powered-dn    Policy trigger initiated reset: Stdby has lower mem than active
...
```

If the standby Supervisor-1 Module is not in the **powered-dn** state, then manually power it down with the **out-of-service module slot** command where *slot* indicates the chassis slot number in which the standby supervisor module is located.

```
switch(config)# out-of-service module 6
```

After executing the **out-of-service module** command, verify that the Module is in the powered-down state by running the **show module** command.

If the **out-of-service module** command fails then check the migration status using the **show logging onboard migration status** command on any management session.

### Step 16

Physically replace the powered-down Supervisor-1 Module (slot 6) with the second Supervisor-4 Module. To replace the supervisor module, follow the steps explained in the [“Removing a Supervisor Module”](#) section and the [“Installing a Supervisor Module”](#) section .

The following messages are displayed when the Supervisor-1 Module is removed:

```
2019 Jun 25 15:21:13 switch %PLATFORM-2-SINGLE_EJECTOR_STAT_CHANGED: Ejector's status in slot 6 has
changed, Ejector is OPEN
2019 Jun 25 15:21:15 switch %PLATFORM-2-MOD_REMOVE: Module 6 removed (Serial number JAE17440HVB)
```

After inserting the new standby Supervisor-4 Module, the following messages are displayed:

```
2019 Jun 25 15:21:27 switch %PLATFORM-2-MODULE_EJECTOR_POLICY_ENABLED: All Ejectors closed for
module 6. Ejector based shutdown enabled
2019 Jun 25 15:21:27 switch %PLATFORM-2-MOD_DETECT: Module 6 detected (Serial number :unavailable)
Module-Type Supervisor Module-4 Model :unavailable
```

**Step 17**

Wait for approximately 20 minutes for the new Supervisor-4 Module to come up in the HA-standby state. Once the standby supervisor module is in the HA-standby state, and the supervisor hardware migration process is complete. The supervisor migration command lock is removed and configuration changes may be made. The supervisor Status LED will be green.

The following messages are displayed on the active Supervisor-4 Module:

```
2019 Jun 25 15:36:45 switch %USBHSD-STANDBY-2-MOUNT: logflash: online
2019 Jun 25 15:36:49 switch %BOOTVAR-5-NEIGHBOR_UPDATE_AUTOCOPY: auto-copy supported by neighbor
supervisor, starting...
2019 Jun 25 15:38:30 switch %PLATFORM-1-PFM_ALERT: Disabling ejector based shutdown on sup in slot
6
2019 Jun 25 15:39:38 switch %MODULE-5-STANDBY_SUP_OK: Supervisor 6 is standby
2019 Jun 25 15:39:39 switch %PLATFORM-1-PFM_ALERT: Enabling ejector based shutdown on sup in slot
5
```

If you see the following failure message, ignore it as the active Supervisor-4 Module will pause the standby Supervisor-4 Module initialization process for a while and then automatically restart the standby initialization process.

```
2019 Jun 25 15:36:45 switch %SYSMGR-2-STANDBY_BOOT_FAILED: Standby supervisor failed to boot up.
```

**Step 18**

Reinstall any previously backed up the license files on the new Supervisor-4 Modules.

```
switch(config)# copy usb1:$(SWITCHNAME)_licenses_archive_file_name.tar bootflash:switch_license.tar
Copy progress 100% 10KB
Copy complete, now saving to disk (please wait)...
```

```
switch(config)# copy bootflash:$(SWITCHNAME)_licenses_archive_file_name.tar
bootflash:switch_license.lic
Copy progress 100% 10KB
Copy complete, now saving to disk (please wait)...
```

```
switch(config)# install license bootflash:switch_license.lic
```

```
Installing license.....done
```

```
switch# show license usage
```

Feature	Ins	Lic Count	Status	Expiry Date	Comments
IOA_X9334	No	0	In use		Grace 115D 2H
FM_SERVER_PKG	No	-	Unused		-
MAINFRAME_PKG	No	-	Unused		-
ENTERPRISE_PKG	Yes	-	Unused never		-
SAN_ANALYTICS_PKG	No	-	In use		Grace 119D 20H
SAN_TELEMETRY_PKG	No	-	Unused		Grace 109D 1H

**Note** \$(SWITCHNAME) adds the switch's switchname to the filename.

**Note** After the supervisor module migration, all license expiry dates will be set to the same dates as before the migration. After a license grace period has expired, all features using the license will be disabled and the configurations will be removed. If a license (of any term) has expired, it will remain enabled after the supervisor migration until a switch reboot.

Refer the [“Verification” section](#) to verify that the Supervisor-1 Module configuration has been successfully applied to the Supervisor-4 Module.

To view the inventory information for modules from the Cisco DCNM Web UI, Choose **Inventory > View > Modules**. The **Modules** window is displayed with a list of all the switches and its details for a selected scope.

For more information, see the *Cisco DCNM SAN Management Configuration Guide*.

### What to do next

Migrate the Crossbar Fabric-1 Switching Modules to Crossbar Fabric-3 Switching Modules. For more information, see the [“Nondisruptive Migration from Crossbar Fabric-1 Switching Modules to Crossbar Fabric-3 Switching Modules”](#) section.

## Nondisruptive Supervisor-4 Migration on Single Supervisor Switch

To perform a nondisruptive migration from a Supervisor-1/Supervisor-1E Module to a Supervisor-4 Module in a switch that has only the active supervisor module installed and there is no standby supervisor module, or the standby module is not in the HA-standby state, follow these steps:

### Before you begin



**Note** In the following procedure, all show outputs, system messages, and image file names are displayed for the Cisco MDS 9710 Multilayer Director Switch. The show outputs, system messages, and image file names will vary based on the Cisco MDS 9700 Series Multilayer Director Switch selected.

### Procedure

**Step 1** Use the **show module** command to view the Active and Standby supervisor modules.

**Note** In the following system messages, Supervisor-1 Module (DS-X97-SF1-K9) is listed as Supervisor Module-3.

```
switch# show module
```

Mod	Ports	Module-Type	Model	Status
1	48	1/10 Gbps Ethernet Module	DS-X9848-480K9	ok
2	48	2/4/8/10/16 Gbps Advanced FC Module	DS-X9448-768K9	ok
3	24	40 Gbps FCoE Module	DS-X9824-960K9	ok
4	48	4/8/16/32 Gbps Advanced FC Module	DS-X9648-1536K9	ok
5	0	Supervisor Module-3	DS-X97-SF1-K9	active *
7	34	1/10/40G IPS, 2/4/8/10/16G FC Module	DS-X9334-K9	ok
8	48	4/8/16/32 Gbps Advanced FC Module	DS-X9648-1536K9	ok
10	48	2/4/8/10/16 Gbps Advanced FC Module	DS-X9448-768K9	ok

Mod	Sw	Hw
1	8.4(1)	1.1
2	8.4(1)	1.3
3	8.4(1)	1.0
4	8.4(1)	1.0
5	8.4(1)	1.3
6	8.4(1)	1.1
7	8.4(1)	1.0
8	8.4(1)	1.0

10 8.4 (1) 1.1

Mod	MAC-Address (es)	Serial-Num
1	84-78-ac-1b-3d-58 to 84-78-ac-1b-3d-8b	JAF1718AAD
2	f4-cf-e2-7c-cd-30 to f4-cf-e2-7c-cd-33	JAE1847038X
3	04-6c-9d-32-36-aa to 04-6c-9d-32-37-1b	JAE19330ASN
4	00-76-86-bf-58-23 to 00-76-86-bf-58-57	JAE203901ZG
5	9c-57-ad-fd-0d-cb to 9c-57-ad-fd-0d-dd	JAE194005JC
6	e8-ed-f3-e5-9a-4d to e8-ed-f3-e5-9a-5f	JAE17440HVB
7	00-da-55-a2-25-00 to 00-da-55-a2-25-0f	JAE195004XM
8	74-86-0b-33-c6-70 to 74-86-0b-33-c6-a4	JAE213101Q3
10	3c-0e-23-c5-53-d0 to 3c-0e-23-c5-53-d3	JAE180605X3

Mod	Online Diag Status
1	Pass
2	Pass
3	Pass
4	Pass
5	Pass
6	Pass
7	Pass
8	Pass
10	Pass

Xbar	Ports	Module-Type	Model	Status
1	0	Fabric Module 1	DS-X9710-FAB1	ok
2	0	Fabric Module 1	DS-X9710-FAB1	ok
3	0	Fabric Module 1	DS-X9710-FAB1	ok
4	0	Fabric Module 1	DS-X9710-FAB1	ok
5	0	Fabric Module 1	DS-X9710-FAB1	ok
6	0	Fabric Module 1	DS-X9710-FAB1	ok

Xbar	Sw	Hw
1	NA	1.0
2	NA	1.0
3	NA	1.0
4	NA	1.0
5	NA	1.0
6	NA	1.0

Xbar	MAC-Address (es)	Serial-Num
1	NA	JAE222305VS
2	NA	JAE2217096X
3	NA	JAE222305V5
4	NA	JAE2217096L
5	NA	JAE2217096J
6	NA	JAE222305V8

**Step 2** Ensure that the required space is available in the bootflash: directory for the image files to be copied using the **dir bootflash:** command. Use the **delete bootflash:filename** command to remove any individual files.

**Step 3** Copy the Supervisor-4 Module Cisco NX-OS kickstart and system images to the active supervisor module bootflash using an FTP, TFTP, SCP, SFTP server, or a USB flash drive.

The Supervisor-4 images contain the string **sf4** to identify them. Do not rename the images; use the standard image names.

```
switch# copy tftp://tftpserver.cisco.com/MDS/m9700-sf4ek9-kickstart-mz.8.4.1.bin
bootflash:m9700-sf4ek9-kickstart-mz.8.4.1.bin
switch# copy tftp://tftpserver.cisco.com/MDS/m9700-sf4ek9-mz.8.4.1.bin
bootflash:m9700-sf4ek9-mz.8.4.1.bin
```

**Note** Ensure that the running Supervisor-1 Cisco MDS NX-OS and the target Supervisor-4 Cisco MDS NX-OS release versions are the same. Use the show version command to view the version of the Cisco MDS NX-OS software running on the switch.

**Step 4** Execute the supervisor migration command:

```
switch# configure terminal
switch(config)# migrate sup kickstart m9700-sf4ek9-kickstart-mz.8.4.1.bin
system m9700-sf4ek9-mz.8.4.1.bin
Kickstart image file is /bootflash/m9700-sf4ek9-kickstart-mz.8.4.1.bin
System image file is /bootflash/m9700-sf4ek9-kickstart-mz.8.4.1.bin
```

**Step 5** During the migration, enter “y” when prompted to do so.

**Note** After this point, the migration process will be locked and you cannot cancel the migration process. The migration command will then check if it has to initiate a single supervisor or dual supervisor migration process by checking if there a standby Supervisor-1 Module is installed in the switch.

**Note** In the following system messages, Supervisor-1 Module (DS-X97-SF1-K9) is listed as Supervisor Module-3.

```
This will start the Supervisor-3 to Supervisor-4 migration. Configuration will be locked
until migration is complete.
Do you wish to continue (y/n) [n] y
```

The following syslog is displayed:

```
<Tue Jun 25 15:06:56 2019> Starting migration,
Please do not remove any linecards or fabric cards until migration is complete
```

**Step 6** Insert the new Supervisor-4 Module, as explained in [Removing a Supervisor Module, on page 117](#) and [Installing a Supervisor Module, on page 115](#). When the Supervisor-4 Module is detected in the standby supervisor slot, a boot from a network (TFTP) server is initiated with the image that is provided by using the migration command.

**Note** You have to insert the Supervisor-4 Module into the switch within a period of 30 minutes after initiating the migration command. In case you have not inserted the Supervisor-4 Module within the 30 minutes after executing the command, you have to execute the command again and re-initiate the migration process.

```
<Tue Jun 25 15:06:57 2019> Manual-boot is enabled for Standby Supervisor
<Tue Jun 25 15:06:57 2019> Please insert Supervisor-4 (DS-X97-SF4-K9) in slot
number: 6 within 30 minutes
```

**Note** After the Supervisor-4 Module is inserted in the slot, a timer is started for the Supervisor-4 Module to power up and come online. If the Supervisor-4 Module fails to power up and come online at the first attempt, a retry is initiated every 15 minutes. In case the Supervisor-4 Module fails to come online after three retries or 45 minutes, you have to remove the Supervisor-4 Module and restart the migration process.

The following system messages are displayed:

```
<Tue Jun 25 15:08:07 2019> Supervisor-4 (DS-X97-SF4-K9) detected in slot 6.
<Tue Jun 25 15:08:12 2019> Reloading standby. This might take up to 15 minutes. Please wait
..
2019 Jun 25 15:08:13 switch %PLATFORM-2-PFM_STANDBY_MODULE_RESET_MIGRATION: Reloading
Standby Supervisor as part of Supervisor migration
```



**Step 7** Wait for approximately 20 minutes for the new Supervisor-4 Module to come up in HA-standby state.

The following messages are displayed on the active Supervisor-1 Module:

```
<Tue Jun 25 15:10:13 2019> Standby supervisor not yet online. This will take some time.
Please wait...
<Tue Jun 25 15:12:13 2019> Standby supervisor not yet online. This will take some time.
Please wait...

2019 Jun 25 15:12:18 switch %SYSMGR-2-ACTIVE_LOWER_MEM_THAN_STANDBY: Active supervisor in
slot 5 is running with less memory than standby supervisor in slot 6.
2019 Jun 25 15:12:18 switch %USBHSD-STANDBY-2-MOUNT: logflash: online
2019 Jun 25 15:12:18 switch %BOOTVAR-5-NEIGHBOR_UPDATE_AUTOCOPY: auto-copy supported by
neighbor supervisor, starting...
<Tue Jun 25 15:14:13 2019> Standby supervisor not yet online. This will take some time.
Please wait...
2019 Jun 25 15:14:05 switch %PLATFORM-1-PFM_ALERT: Disabling ejector based shutdown on sup
in slot 6
<Tue Jun 25 15:14:13 2019> Standby supervisor not yet online. This will take some time.
Please wait...
```

**Note** If you see the following failure message, ignore it as, the active Supervisor-1 Module will bring up the standby Supervisor-4 Module to HA-standby supervisor state in some time.

```
2019 Jun 25 15:15:06 switch %SYSMGR-2-STANDBY_BOOT_FAILED: Standby supervisor failed to
boot up.
```

The following messages are displayed when the standby module is online:

```
2019 Jun 25 15:15:06 switch %CARDCLIENT-2-SSE: MOD:6 SUP ONLINE
2019 Jun 25 15:15:07 switch %MODULE-5-STANDBY_SUP_OK: Supervisor 6 is standby
2019 Jun 25 15:15:08 switch %PLATFORM-1-PFM_ALERT: Enabling ejector based shutdown on sup
in slot 6
<Tue Jun 25 15:15:33 2019> Standby Supervisor-4 (DS-X97-SF4-K9) has come online, configs
will be copied
```

**Step 8** The current configuration will be synchronized to the new standby supervisor by automatically executing **copy running-config startup-config**. After this a supervisor switchover is initiated. Any SSH/Telnet sessions to the switch will be terminated at this point.

The following messages are displayed:

```
<Tue Jun 25 15:15:33 2019> Saving configuration now. Please wait...
[#####] 100%
Copy complete.
/mnt/plog/migration.log:                2.91 kB   74.67 kB/s
<Tue Jun 25 15:15:46 2019> Supervisor-3 (DS-X97-SF1-K9) will switchover to Supervisor-4
(DS-X97-SF4-K9) now
<Tue Jun 25 15:15:47 2019> Switchover is successful, Supervisor-4 (DS-X97-SF4-K9) is now active
```

**Step 9** The supervisor switchover changes the new Supervisor-4 Module from HA standby to Active state. If using SSH/Telnet reconnect several seconds after the switchover. Ensure that the console link and the management link are connected to the Supervisor-4 Module. The old active Supervisor-1 Module will be powered down. The supervisor Status LED will be blinking red when the supervisor module is powered down by the migration command. If the Status LED is not blinking red, then check the migration status using the **show logging onboard migration status** command on any management session.

The following syslog message is displayed on the active Supervisor-4 Module:

```
2019 Jun 25 15:15:47 switch %SYSMGR-2-HASWITCHOVER_PRE_START: This supervisor is becoming active
(pre-start phase).
2019 Jun 25 15:15:48 switch %SYSMGR-2-HASWITCHOVER_START: Supervisor 6 is becoming active.
```

```

2019 Jun 25 15:15:48 switch %IPS-5-IPS_MGR_FEATURE_ENABLE: Restore cond runtime ips:0 iscsi:0 fcip:0
  iscsi-intf-vsana:0 ips-lc:1
2019 Jun 25 15:15:48 switch %ASCII-CFG-6-INFORMATION: Reading ACFG Runtime information
2019 Jun 25 15:15:48 switch %SYSMGR-2-SWITCHOVER_OVER: Switchover completed.
2019 Jun 25 15:15:48 switch %PLATFORM-1-PFM_ALERT: Disabling ejector based shutdown on sup in slot
  6

2019 Jun 25 15:15:50 switch %BOOTVAR-2-SUP_MIGRATION_CONFIG_STARTED: Setting boot parameters for
  supervisor migration process. It might take some time. Please do not set any config parameters
  during this time.

2019 Jun 25 15:15:52 switch %PLATFORM-2-SUP_UNSUPPORTED: Unsupported card detected in supervisor
  slot 5 powered down
2019 Jun 25 15:15:52 switch %PLATFORM-2-MOD_PWRDN: Module 5 powered down (Serial number)
2019 Jun 25 15:15:52 switch %PLATFORM-5-MOD_STATUS: Module 5 current-status is
  MOD_STATUS_CONFIGPOWERED_DOWN
2019 Jun 25 15:15:53 switch %PLATFORM-5-MOD_STATUS: Module 5 current-status is MOD_STATUS_POWERED_DOWN

```

**Step 10**

After the successful completion of the system switchover, the following syslog message is displayed:

```

2019 Jun 25 15:16:39 switch %BOOTVAR-2-SUP_MIGRATION_CONFIG_COMPLETE: Migration process is complete
  now. Supervisor-3 (DS-X97-SF1-K9) in standby slot can now be replaced with Supervisor-4
  (DS-X97-SF4-K9).
2019 Jun 25 15:18:00 switch %SYSMGR-2-SBY_SUP_LESS_MEMORY_SLOT: Supervisor in slot 6 is running
  with less memory than active supervisor in slot 5
2019 Jun 25 15:18:00 switch %SYSMGR-2-CONVERT_STARTUP_ABORTED: Conversion of startup-config failed.
2019 Jun 25 15:18:00 switch %PLATFORM-2-MOD_PWRDN: Module 6 powered down (Serial number JAE17440HVB)
2019 Jun 25 15:18:00 switch %PLATFORM-5-MOD_STATUS: Module 6 current-status is
  MOD_STATUS_CONFIGPOWERED_DOWN
2019 Jun 25 15:18:00 switch %PLATFORM-5-MOD_STATUS: Module 6 current-status is MOD_STATUS_POWERED_DOWN
2019 Jun 25 15:18:00 switch %PLATFORM-2-MOD_REMOVE: Module 6 removed (Serial number JAE17440HVB)

```

**Warning** A mix of different Supervisor-4 Modules and Supervisor-1/Supervisor-1E Modules outside the migration process is not supported. This mix of modules is supported only while you are migrating from a Supervisor-1/Supervisor-1E Module to a Supervisor-4 Module. If there is mix of Supervisor-1 and Supervisor-4 module, the chassis will power down the standby supervisor module, and the first supervisor module that comes up will become the active supervisor.

**Step 11**

(Optional) The system will automatically start the boot parameter setup for the supervisor migration process. Do not set any configuration parameters until the boot parameters are set. After the boot parameters are set, the migration process is completed for the first supervisor module. Use the **show boot** command to verify the current boot variables and the **show module** command to display the modules installed in the switch.

**Supervisor-4 Module outputs**

```

switch# show boot
kickstart variable = bootflash:/m9700-sf4ek9-kickstart-mz.8.4.1.bin
system variable = bootflash:/m9700-sf4ek9-mz.8.4.1.bin
Boot POAP Disabled

```

```

switch# show module

```

Mod	Ports	Module-Type	Model	Status
1	48	4/8/16/32 Gbps Advanced FC Module	DS-X9648-1536K9	ok
2	48	4/8/16/32 Gbps Advanced FC Module	DS-X9648-1536K9	ok
3	48	2/4/8/10/16 Gbps Advanced FC Module	DS-X9448-768K9	ok
4	48	4/8/16/32 Gbps Advanced FC Module	DS-X9648-1536K9	ok
5	0	Supervisor Module-3	DS-X97-SF1-K9	powered-dn
6	0	Supervisor Module-4	DS-X97-SF4-K9	active *

```

7    48    2/4/8/10/16 Gbps Advanced FC Module DS-X9448-768K9    ok
8    48    1/10 Gbps Ethernet Module             DS-X9848-480K9    ok
10   34    1/10/40G IPS,2/4/8/10/16G FC Module DS-X9334-K9      ok

```

```
Mod Power-Status Reason
-----
```

```
6    powered-dn    Policy trigger initiated reset: Stdby has lower mem than active

```

```
Mod Sw          Hw
-----
```

```

1    8.4(1)        1.1
2    8.4(1)        1.3
3    8.4(1)        1.0
4    8.4(1)        1.0
5    8.4(1)        1.0
6    8.4(1)        1.1
7    8.4(1)        1.0
8    8.4(1)        1.0
10   8.4(1)        1.1

```

```
Mod MAC-Address(es)          Serial-Num
-----
```

```

1    84-78-ac-1b-3d-58 to 84-78-ac-1b-3d-8b JAF1718AAAD
2    f4-cf-e2-7c-cd-30 to f4-cf-e2-7c-cd-33 JAE1847038X
3    04-6c-9d-32-36-aa to 04-6c-9d-32-37-1b JAE19330ASN
4    00-76-86-bf-58-23 to 00-76-86-bf-58-57 JAE203901ZG
5    00-2f-5c-fc-54-0a to 00-2f-5c-fc-54-1d JAE22440CB1
6    00-00-00-00-00-00 to 00-00-00-00-00-00 NA
7    00-da-55-a2-25-00 to 00-da-55-a2-25-0f JAE195004XM
8    74-86-0b-33-c6-70 to 74-86-0b-33-c6-a4 JAE213101Q3
10   3c-0e-23-c5-53-d0 to 3c-0e-23-c5-53-d3 JAE180605X3

```

```
Mod Online Diag Status
-----
```

```

1    Pass
2    Pass
3    Pass
4    Pass
5    Pass
7    Pass
8    Pass
10   Pass

```

```
Xbar Ports  Module-Type          Model          Status
-----
```

```

1    0    Fabric Module 1      DS-X9710-FAB1    ok
2    0    Fabric Module 1      DS-X9710-FAB1    ok
3    0    Fabric Module 1      DS-X9710-FAB1    ok
4    0    Fabric Module 1      DS-X9710-FAB1    ok
5    0    Fabric Module 1      DS-X9710-FAB1    ok
6    0    Fabric Module 1      DS-X9710-FAB1    ok

```

```
Xbar Sw          Hw
-----
```

```

1    NA          1.0
2    NA          1.0
3    NA          1.0
4    NA          1.0
5    NA          1.0
6    NA          1.0

```

```
Xbar MAC-Address(es)          Serial-Num
```

```

-----
1   NA                               JAE222305VS
2   NA                               JAE2217096X
3   NA                               JAE222305V5
4   NA                               JAE2217096L
5   NA                               JAE2217096J
6   NA                               JAE222305V8

```

**Step 12** Reinstall the license files on the new Supervisor-4 Module.

```
switch(config)# copy usb1:licenses_archive_file_name.tar bootflash:switch_license.tar
```

```
Copy progress 100% 10KB
Copy complete, now saving to disk (please wait)...
```

```
switch(config)# copy bootflash:switch_license.tar bootflash:switch_license.lic
```

```
Copy progress 100% 10KB
Copy complete, now saving to disk (please wait)...
```

```
switch(config)# install license bootflash:switch_license.lic
```

```
Installing license.....done
```

```
switch# show license usage
```

Feature	Ins	Lic Count	Status	Expiry Date	Comments
IOA_X9334	No	0	In use		Grace 115D 2H
FM_SERVER_PKG	No	-	Unused		-
MAINFRAME_PKG	No	-	Unused		-
ENTERPRISE_PKG	Yes	-	Unused	never	-
SAN_ANALYTICS_PKG	No	-	In use		Grace 119D 20H
SAN_TELEMETRY_PKG	No	-	Unused		Grace 109D 1H

**Step 13** If the standby Supervisor-1 Module is not in the powered down state, then put the standby Supervisor-1 Module to out of service, using the **out-of-service module slot** command .

Where a *slot* indicates the chassis slot number in which the standby supervisor module resides.

```
switch(config)# out-of-service module 6
```

**Step 14** Remove the Supervisor -1 Module from the chassis.

Refer the [“Verification” section](#) to verify that the Supervisor-1 Module configurations are successfully applied to the Supervisor-4 Module.

To view the inventory information for modules from the Cisco DCNM Web UI, Choose **Inventory > View > Modules**. The **Modules** window is displayed with a list of all the switches and its details for a selected scope.

For more information, see the *Cisco DCNM SAN Management Configuration Guide*.

### What to do next

Migrate the Crossbar Fabric-1 Switching Modules to Crossbar Fabric-3 Switching Modules. For more information, see the [“Nondisruptive Migration from Crossbar Fabric-1 Switching Modules to Crossbar Fabric-3 Switching Modules” section](#)

## Supervisor-4 Migration Verification

Use the following **show** commands to verify the migration procedure for the Supervisor-4 Module:

- **show version**
- **show module**
- **show interface brief**
- **show interface status**
- **show system redundancy status**

### Sample output for the show version command on the Supervisor-4 Module

In the following procedure, all show outputs, system messages, and image file names are displayed for the Cisco MDS 9710 Multilayer Director Switch. The show outputs, system messages, and image file names will vary based on the Cisco MDS 9700 Series Multilayer Director Switch selected.

```
switch# show version
Cisco Nexus Operating System (NX-OS) Software
TAC support: http://www.cisco.com/tac
Documents: http://www.cisco.com/en/US/products/ps9372/tsd_products_support_series_home.html
Copyright (c) 2002-2019, Cisco Systems, Inc. All rights reserved.
The copyrights to certain works contained in this software are
owned by other third parties and used and distributed under
license. Certain components of this software are licensed under
the GNU General Public License (GPL) version 2.0 or the GNU
Lesser General Public License (LGPL) Version 2.1. A copy of each
such license is available at
http://www.opensource.org/licenses/gpl-2.0.php and
http://www.opensource.org/licenses/lgpl-2.1.php

Software
  BIOS:          version 2.6.0
  kickstart:    version 8.4(1)
  system:       version 8.4(1)
  BIOS compile time:      05/17/2019
  kickstart image file is: bootflash:///m9700-sf4ek9-kickstart-mz.8.4.1.bin
  kickstart compile time: 6/30/2019 23:00:00 [06/15/2019 14:49:08]
  system image file is:   bootflash:///m9700-sf4ek9-mz.8.4.1.bin
  system compile time:   6/30/2019 23:00:00 [06/15/2019 16:15:18]

Hardware
  cisco MDS 9710 (10 Slot) Chassis ("Supervisor Module-4")
  Intel(R) Xeon(R) CPU D-1548 with 14270332 kB of memory.
  Processor Board ID JAE22440CB1

  Device name: switch
  bootflash:   3932160 kB
  slot0:      0 kB (expansion flash)

Kernel uptime is 0 day(s), 0 hour(s), 36 minute(s), 9 second(s)

Last reset
  Reason: Unknown
  System version: 8.4(1)
  Service:
```

```
plugin
  Core Plugin, Ethernet Plugin
```

```
Active Package(s)
```

### Sample output for the show module command on the Supervisor-4 Module for a dual supervisor migration

```
switch# show module
```

Mod	Ports	Module-Type	Model	Status
1	48	1/10 Gbps Ethernet Module	DS-X9848-480K9	ok
2	48	2/4/8/10/16 Gbps Advanced FC Module	DS-X9448-768K9	ok
3	24	40 Gbps FCoE Module	DS-X9824-960K9	ok
4	48	4/8/16/32 Gbps Advanced FC Module	DS-X9648-1536K9	ok
5	0	Supervisor Module-4	DS-X97-SF4-K9	active *
6	0	Supervisor Module-4	DS-X97-SF4-K9	ha-standby
7	34	1/10/40G IPS,2/4/8/10/16G FC Module	DS-X9334-K9	ok
8	48	4/8/16/32 Gbps Advanced FC Module	DS-X9648-1536K9	ok
10	48	2/4/8/10/16 Gbps Advanced FC Module	DS-X9448-768K9	ok

Mod	Sw	Hw
1	8.4(1)	1.1
2	8.4(1)	1.3
3	8.4(1)	1.0
4	8.4(1)	1.0
5	8.4(1)	1.0
6	8.4(1)	1.0
7	8.4(1)	1.0
8	8.4(1)	1.0
10	8.4(1)	1.1

Mod	MAC-Address(es)	Serial-Num
1	84-78-ac-1b-3d-58 to 84-78-ac-1b-3d-8b	JAF1718AAAD
2	f4-cf-e2-7c-cd-30 to f4-cf-e2-7c-cd-33	JAE1847038X
3	04-6c-9d-32-36-aa to 04-6c-9d-32-37-1b	JAE19330ASN
4	00-76-86-bf-58-23 to 00-76-86-bf-58-57	JAE203901ZG
5	00-2f-5c-fc-54-0a to 00-2f-5c-fc-54-1d	JAE22440CB1
6	00-2f-5c-fc-81-b4 to 00-2f-5c-fc-81-c7	JAE22490XKJ
7	00-da-55-a2-25-00 to 00-da-55-a2-25-0f	JAE195004XM
8	74-86-0b-33-c6-70 to 74-86-0b-33-c6-a4	JAE213101Q3
10	3c-0e-23-c5-53-d0 to 3c-0e-23-c5-53-d3	JAE180605X3

Mod	Online Diag Status
1	Pass
2	Pass
3	Pass
4	Pass
5	Pass
6	Pass
7	Pass
8	Pass
10	Pass

Xbar	Ports	Module-Type	Model	Status
---	---	-----	-----	-----

1	0	Fabric Module 1	DS-X9710-FAB1	ok
2	0	Fabric Module 1	DS-X9710-FAB1	ok
3	0	Fabric Module 1	DS-X9710-FAB1	ok
4	0	Fabric Module 1	DS-X9710-FAB1	ok
5	0	Fabric Module 1	DS-X9710-FAB1	ok
6	0	Fabric Module 1	DS-X9710-FAB1	ok

Xbar	Sw	Hw
1	NA	1.0
2	NA	1.0
3	NA	1.0
4	NA	1.0
5	NA	1.0
6	NA	1.0

Xbar	MAC-Address(es)	Serial-Num
1	NA	JAE222305VS
2	NA	JAE2217096X
3	NA	JAE222305V5
4	NA	JAE2217096L
5	NA	JAE2217096J
6	NA	JAE222305V8

### Sample output for the show inventory command on the Supervisor-4 Module:

```
switch# show inventory

NAME: "Chassis", DESCR: "MDS 9710 (10 Slot) Chassis "
PID: DS-C9710 , VID: V00, SN: JAF1647AQTL

NAME: "Slot 1", DESCR: "1/10 Gbps Ethernet Module"
PID: DS-X9848-480K9 , VID: V01, SN: JAF1718AAAD

NAME: "Slot 2", DESCR: "2/4/8/10/16 Gbps Advanced FC Module"
PID: DS-X9448-768K9 , VID: V02, SN: JAE1847038X

NAME: "Slot 3", DESCR: "40 Gbps FCoE Module"
PID: DS-X9824-960K9 , VID: V00, SN: JAE19330ASN

NAME: "Slot 4", DESCR: "4/8/16/32 Gbps Advanced FC Module"
PID: DS-X9648-1536K9 , VID: V01, SN: JAE203901ZG

NAME: "Slot 5", DESCR: "Supervisor Module-3"
PID: DS-X97-SF1-K9 , VID: V02, SN: JAE194005JC

NAME: "Slot 6", DESCR: "Supervisor Module-3"
PID: DS-X97-SF1-K9 , VID: V02, SN: JAE17440HVB

NAME: "Slot 7", DESCR: "1/10/40G IPS,2/4/8/10/16G FC Module"
PID: DS-X9334-K9 , VID: V00, SN: JAE195004XM

NAME: "Slot 8", DESCR: "4/8/16/32 Gbps Advanced FC Module"
PID: DS-X9648-1536K9 , VID: V01, SN: JAE213101Q3

NAME: "Slot 10", DESCR: "2/4/8/10/16 Gbps Advanced FC Module"
PID: DS-X9448-768K9 , VID: V01, SN: JAE180605X3

NAME: "Slot 11", DESCR: "Fabric card module"
PID: DS-X9710-FAB1 , VID: V00, SN: JAE222305VS
```

```

NAME: "Slot 12",  DESCR: "Fabric card module"
PID: DS-X9710-FAB1      ,  VID: V00,  SN: JAE2217096X

NAME: "Slot 13",  DESCR: "Fabric card module"
PID: DS-X9710-FAB1      ,  VID: V00,  SN: JAE222305V5

NAME: "Slot 14",  DESCR: "Fabric card module"
PID: DS-X9710-FAB1      ,  VID: V00,  SN: JAE2217096L

NAME: "Slot 15",  DESCR: "Fabric card module"
PID: DS-X9710-FAB1      ,  VID: V00,  SN: JAE2217096J

NAME: "Slot 16",  DESCR: "Fabric card module"
PID: DS-X9710-FAB1      ,  VID: V00,  SN: JAE222305V8

NAME: "Slot 35",  DESCR: "MDS 9710 (10 Slot) Chassis Power Supply"
PID: DS-CAC97-3KW       ,  VID: V01,  SN: DTM164602XH

NAME: "Slot 37",  DESCR: "MDS 9710 (10 Slot) Chassis Power Supply"
PID: DS-CAC97-3KW       ,  VID: V01,  SN: DTM1649022W

NAME: "Slot 38",  DESCR: "MDS 9710 (10 Slot) Chassis Power Supply"
PID: DS-CAC97-3KW       ,  VID: V01,  SN: DTM16490239

NAME: "Slot 39",  DESCR: "MDS 9710 (10 Slot) Chassis Power Supply"
PID: DS-CAC97-3KW       ,  VID: V01,  SN: DTM164602ZP

NAME: "Slot 41",  DESCR: "MDS 9710 (10 Slot) Chassis Fan Module"
PID: DS-C9710-FAN       ,  VID: V00,  SN: JAF1647ADCE

NAME: "Slot 42",  DESCR: "MDS 9710 (10 Slot) Chassis Fan Module"
PID: DS-C9710-FAN       ,  VID: V00,  SN: JAF1647ADCN

NAME: "Slot 43",  DESCR: "MDS 9710 (10 Slot) Chassis Fan Module"
PID: DS-C9710-FAN       ,  VID: V00,  SN: JAF1647ACHH

```

### Sample output for the show interface brief command on the Supervisor-4 Module:

```
switch# show interface brief
```

```

-----
Interface  Vsan   Admin  Admin  Status      SFP   Oper  Oper  Port  Logical
          Mode   Trunk
          Mode
-----
fc1/1      1       E       on     trunking    swl   TE   16   1     core
fc1/2      1       E       on     trunking    swl   TE   16   1     core
fc1/3      1       E       on     trunking    swl   TE   16   1     core
fc1/4      1       E       on     trunking    swl   TE   16   1     core
fc1/5      1       E       on     trunking    swl   TE   16   1     core
fc1/6      1       E       on     notConnected swl   --   --   --     --
fc1/7      20      auto    off    up          swl   F    8    --     edge
fc1/8      20      F       off    up          swl   F    16   --     edge

```



**Sample output for the show interface status command on the Supervisor-4 Module:**

```
switch# show interface status
fc1/1 is down (SFP not present)
fc1/2 is down (Administratively down)
fc1/3 is down (Error disabled - SFP vendor not supported)
fc1/4 is down (Error disabled - SFP vendor not supported)
fc1/5 is down (Administratively down)
fc1/6 is down (Administratively down)
fc1/7 is down (SFP not present)
fc1/8 is down (SFP not present)
fc1/9 is down (SFP not present)
fc1/10 is down (SFP not present)
fc1/11 is down (Administratively down)
fc1/12 is down (Administratively down)
fc1/13 is down (SFP not present)
fc1/14 is down (SFP not present)
fc1/15 is down (Administratively down)
fc1/16 is down (Administratively down)
fc1/17 is down (SFP not present)
fc1/18 is down (SFP not present)
fc1/19 is down (SFP not present)
fc1/20 is down (SFP not present)
```

**Sample output for the show system redundancy status command on the Supervisor-4 Module:**

```
switch# show system redundancy status

Redundancy mode
-----
administrative: HA
operational: HA
This supervisor (sup-6)
-----
Redundancy state: Active
Supervisor state: Active
Internal state: Active with HA standby
Other supervisor (sup-5)
-----
Redundancy state: Standby
Supervisor state: HA standby
Internal state: HA standby
```

## Supervisor-4 Migration Clean Up

This section describes how to clean up if the supervisor migration process fails.

In case any migration clean-up errors have been detected on the Supervisor-1 Module, the following syslog message is displayed:

```
<Tue Apr 30 10:02:47 2019> Please run 'migrate clean' before doing any operation.
```

In such a scenario, use the **migrate clean up** command to resolve the errors.

```
switch# migrate clean up
<Tue May 28 03:34:58 2019> Manual-boot is disabled for Standby Supervisor
<Tue May 28 03:34:58 2019> Migration clean up done
```

In case any migration clean-up errors have been detected on the Supervisor-4 Module, the following syslog message is displayed:

```
BOOTVAR-2- MIGRATION_CONFIG_CLEAN_ERROR: Please run 'migrate clean' command from active Supervisor before replacing the standby Supervisor.
```

In such a scenario, use the **migrate clean up** command to resolve the errors.

```
switch# migrate clean up
<Tue May 28 03:34:58 2019> Migration clean up done
```

In case the **migrate clean up** command is used on a Supervisor-1 Module or a Supervisor-4 Module for which migration has not been initiated, the following syslog is displayed:

```
switch# migrate clean up
<Tue May 28 03:34:58 2019> Migration was not done on this Supervisor
```

## Troubleshooting

This section lists the error messages that may come up on the console during the migration along with the recommended action to be performed.

**Problem** Setting boot parameters for supervisor migration process returned error:

```
switch %BOOTVAR-2-SUP_MIGRATION_CONFIG_ERROR: Setting boot parameters for supervisor migration process returned error.
```

**Solution** Set the boot variables manually using the **boot kickstart** *kickstart\_image* command and **boot system** *system\_image* on the Supervisor-4 Module.

**Problem** The kickstart or system image is not present on the bootflash of the active Supervisor-4 Module. The following syslog message is displayed:

```
switch %BOOTVAR-2-SUP_MIGRATION_IMAGE_DOES_NOT_EXIST: System image doesn't exist on bootflash of the supervisor. Please clear some space in bootflash, copy the Supervisor-4 images manually, set the boot variables and save configs before replacing Standby Supervisor-3 (DS-X97-SF1-K9)
```

**Solution** Clear space on the bootflash and then copy the Supervisor-4 Module images manually, as shown in [Step 3](#) in the migration procedures given above. Set the boot variables and save the configuration before replacing the standby Supervisor-1 Module. Use the **boot kickstart** *kickstart\_image* command and the **boot system** *system\_image* command on the active Supervisor-4 Module when it becomes active after the migration is completed.

**Problem** The newly inserted Supervisor-4 Module cannot take over as the active supervisor. The following syslog message is displayed:

```
<Tue Apr 30 10:02:47 2019> ERROR!!! Supervisor-4 (DS-X97-SF4-K9) cannot take over as active Supervisor...
```

**Solution** Wait for the next retry attempt by the switch to bring up the Supervisor-4 Module.

**Problem** The migration logging file is already present in the Supervisor-1 Module. The following syslog message is displayed:

```
<Tue Apr 30 10:02:47 2019> WARNING!!! Migration logging file already exists in Supervisor-3 (DS-X97-SF1-K9), continuing migration...
```

**Solution** None. The **show logging onboard migration status** command is used to monitor the migration progress. There is no impact on the migration process.

**Problem** The switch cannot initiate migration logging due to insufficient file permissions. The following syslog message is displayed:

```
<Tue Apr 30 10:02:47 2019> WARNING!!! Migration logging cannot be done
due to file permission error, continuing migration...
```

**Solution** None. The **show logging onboard migration status** command is used to monitor the migration progress. This error message is displayed if the appropriate file permissions have not been provided.

**Problem** The active Supervisor-1 Module is using the redundant secondary EOBC link instead of the primary EOBC link. The following syslog message is displayed:

```
<Tue Apr 30 10:02:47 2019> ERROR!!! Active Supervisor-3 (DS-X97-SF1-K9) is using Redundant
EOBC link, this indicates some problem with Primary EOBC link, aborting migration...
```

**Solution** Replace the active Supervisor-1 Module with another Supervisor-1 Module.

**Problem** Unable to extract the image header from the kickstart or system images. The following syslog messages are displayed:

```
<Tue Apr 30 10:02:47 2019> ERROR!!! Image header extraction failed for Kickstart image
<kickstart_image> of
Supervisor-4 (DS-X97-SF4-K9), aborting migration...
<Tue Apr 30 10:02:47 2019> ERROR!!! Image header extraction failed for System image
<system_image> of
Supervisor-4 (DS-X97-SF1-K9), aborting migration...
```

**Solution** Use the migration command again.

**Problem** Unable to retrieve the kickstart or system image information. The following syslogs are displayed:

```
<Tue Apr 30 10:02:47 2019> ERROR!!! Failed to get Kickstart image info, aborting migration...
<Tue Apr 30 10:02:47 2019> ERROR!!! Failed to get System image info, aborting migration...
```

**Solution** Use the migration command again.

**Problem** The kickstart or system images provided are not valid images for the Supervisor-4 Modules. The following syslog message is displayed:

```
<Tue Apr 30 10:02:47 2019> ERROR!!! Kickstart image provided '<kickstart_image>' is not a
valid Supervisor-4
(DS-X97-SF4-K9) image, aborting migration...
<Tue Apr 30 10:02:47 2019> ERROR!!! System image provided '<system_image>' is not a valid
Supervisor-4
(DS-X97-SF4-K9) image, aborting migration...
```

**Solution** Use a valid Supervisor-4 Module image and use the migration command again.

**Problem** The release versions of the Supervisor-4 Module kickstart and system images provided are not the same as the existing Supervisor-1 Module kickstart and system images. The following syslog messages are displayed:

```
<Tue Apr 30 10:02:47 2019> ERROR!!! Running kickstart version : <running_version>,
version of kickstart image
provided : <Supervisor-3_image_version>
<Tue Apr 30 10:02:47 2019> ERROR!!! Version of kickstart image provided
('<sup3_image_version>') does not match running
version, aborting migration...
<Tue Apr 30 10:02:47 2019> ERROR!!! Running System version: <running_version>, version of
system image provided :
<Supervisor- 3_image_version>
<Tue Apr 30 10:02:47 2019> ERROR!!! Version of system image provided ('<sup3_image_version>')
```

```
does not match
running version, aborting migration...
```

**Solution** Check the image version. The release versions of the Supervisor-4 Module kickstart and system images provided should be the same as the existing Supervisor-1 Module kickstart and system images.

**Problem** Unable to retrieve the chassis information. The following syslog message is displayed:

```
<Tue Apr 30 10:02:47 2019> ERROR!!! Chassis information retrieve failed, aborting migration...
```

**Solution** Use the migration command again.

**Problem** Unable to retrieve the slot number of the supervisor module. The following syslog message is displayed:

```
<Tue Apr 30 10:02:47 2019> ERROR!!! Supervisor slot information retrieve failed, aborting migration...
```

**Solution** Use the migration command again.

**Problem** The release versions of the Supervisor-4 Module kickstart and system images provided are not the same as the existing Supervisor-1 Module kickstart and system images. The following syslog messages are displayed:

```
<Tue Apr 30 10:02:47 2019> ERROR!!! Running kickstart version : <running_version>,
version of kickstart image provided :
<Supervisor-3_image_version>
<Tue Apr 30 10:02:47 2019> ERROR!!! Version of kickstart image provided
('<sup3_image_version>') does not match running version,
aborting migration...
<Tue Apr 30 10:02:47 2019> ERROR!!! Running System version: <running_version>, version of
system image provided :
<Supervisor- 3_image_version>
<Tue Apr 30 10:02:47 2019> ERROR!!! Version of system image provided ('<sup3_image_version>')
does not match running version,
aborting migration...
```

**Solution** Check the image version. The release versions of the Supervisor-4 Module kickstart and system images provided should be the same as the existing Supervisor-1 Module kickstart and system images.

**Problem** Unable to retrieve the chassis information. The following syslog message is displayed:

```
<Tue Apr 30 10:02:47 2019> ERROR!!! Chassis information retrieve failed, aborting
migration...
```

**Solution** Use the migration command again.

**Problem** Unable to retrieve the slot number of the supervisor module. The following syslog message is displayed:

```
<Tue Apr 30 10:02:47 2019> ERROR!!! Supervisor slot information retrieve failed, aborting
migration...
```

**Solution** Use the migration command again.

**Problem** Unable to retrieve the slot number of the standby supervisor module. The following syslog message is displayed:

```
<Tue Apr 30 10:02:47 2019> ERROR!!! Standby Supervisor slot information retrieve failed,
aborting migration...
```

**Solution** Use the migration command again.

**Problem** In case the migration command cannot read the stored Supervisor-1 Module image links, the migration process fails. The following syslog messages are displayed:

```
<Tue Apr 30 10:02:47 2019> ERROR!!! Kickstart image link for Active
Supervisor-1 (DS-X97-SF1-K9) could not be found, aborting migration...
<Tue Apr 30 10:02:47 2019> Please set the boot parameters using 'boot kickstart
```

```
<kickstart_image>' and 'boot system <system_image>'
<Tue Apr 30 10:02:47 2019> ERROR!!! System image link for Active Supervisor-1
(DS-X97-SF1-K9) could not be found, aborting migration...
<Tue Apr 30 10:02:47 2019> Please set the boot parameters using 'boot kickstart
<kickstart_image>' and 'boot system <system_image>'
```

**Solution** Set the Supervisor-1 Module image links using the **boot kickstart** *kickstart\_image* command and the **boot system** *system\_image* command before re-inserting the standby Supervisor-4 Module.

**Problem** The Supervisor-4 Module is already present in the standby slot before initiating the migration procedure. The following syslog message is displayed:

```
<Tue Apr 30 10:02:47 2019> ERROR!!! Supervisor-4 is already inserted in
standby slot <slot_number> before starting migration. Please remove Standby supervisor
and start single Supervisor migration, aborting migration...
```

**Solution** Remove the standby Supervisor-4 Module and start the migration process again.

**Problem** The standby Supervisor-1 Module is not in the HA-standby state. The following syslog message is displayed:

```
<Tue Apr 30 10:02:47 2019> ERROR!!! Standby Supervisor-3 (DS-X97-SF1-K9)
is not yet in ha-standby state, aborting migration...
<Tue Apr 30 10:02:47 2019> Please wait for Standby supervisor in slot <slot_number>
to become ha-standby or physically remove standby and start migration
```

**Solution** Wait until the standby Supervisor-1 Module comes up in the HA-standby state or remove the standby Supervisor-1 Module and perform a single supervisor migration.

**Problem** In case of a dual supervisor migration, the standby Supervisor-1 Module is powered down by using the **out-of-service** *<slot-number>* command. If the standby Supervisor-1 Module does not power down after using this command, the following syslog message is displayed:

```
<Tue Apr 30 10:02:47 2019> ERROR!!! Failed to power down Standby
Supervisor-3 in slot <slot_number>, aborting migration...
```

**Solution** Use the migration command again.

**Problem** Unable to lock the configuration. The following syslog message is displayed:

```
<Tue Apr 30 10:02:47 2019> ERROR!!! Failed to lock config, aborting migration...
```

**Solution** Use the migration command again.

**Problem** In case a auto-boot is not disabled before the insertion of the Supervisor-4 Module, the following syslog message is displayed:

```
<Tue Apr 30 10:02:47 2019> ERROR!!! Standby Supervisor config failed, aborting migration...
```

**Solution** Use the migration command again.

**Problem** After powering down the Supervisor-1 Module, the switch will check for the presence of a module in the slot from which the Supervisor-1 Module was removed. This check happens every 30 minutes after the Supervisor-1 Module has been removed. In case this check to detect the presence of the supervisor module fails, the following syslog message is displayed:

```
<Tue Apr 30 10:02:47 2019> ERROR!!! Module information retrieve failed
```

**Solution** None. There is no impact on the migration process.

**Problem** A Supervisor-1 Module is inserted instead of a Supervisor-4 Module. The following syslog message is displayed:

```
<Tue Apr 30 10:02:47 2019> ERROR!!! Supervisor-1 (DS-X97-SF1-K9) is inserted in slot
<slot_number> instead of
Supervisor-4 (DS-X97-SF4-K9), aborting migration...
```

**Solution** Restart migration and ensure that the newly inserted supervisor module is the Supervisor-4 Module.

**Problem** In case the Supervisor-4 Module is not inserted into the standby slot within 30 minutes after the Supervisor-1 Module has been powered down, the following syslog message is displayed:

```
module
<Tue Apr 30 10:02:47 2019> ERROR!!! Timeout waiting for Supervisor-4 (DS-X97-SF4-K9)
to be inserted in slot <slot_number>, aborting migration...
```

**Solution** Use the migration command again and ensure that the Supervisor-4 Module is inserted into the standby slot within 30 minutes after the Supervisor-1 Module has been powered down.

**Problem** Unable to create image links for the Supervisor-4 Module images. The following syslog message is displayed:

```
<Tue Apr 30 10:02:47 2019> ERROR!!! Supervisor-4 (DS-X97-SF4-K9) image links
could not be created for Standby Supervisor bootup, aborting migration...
```

**Solution** Use the migration command again.

**Problem** Unable to reload the Supervisor-4 Module after the Supervisor-4 Module is detected in the switch. The following syslog message is displayed:

```
<Tue Apr 30 10:02:47 2019> ERROR!!! Failed to reload
Standby Supervisor-4 (DS-X97-SF4-K9), aborting migration...
```

**Solution** Remove the Supervisor-4 Module from the standby slot and restart migration by using the migration command.

**Problem** The Supervisor-4 Module is stuck in loader prompt due to a boot failure. The following syslog message is displayed:

```
<Tue Apr 30 10:02:47 2019> ERROR!!! Standby Supervisor-4
(DS-X97-SF4-K9) is stuck in loader prompt due to boot-up failure...
```

**Solution** None. A retry attempt to bring up the Supervisor-4 Module is initiated by the switch every 15 minutes for 3 times.

**Problem** The Supervisor-4 Module is unable to come online. The following syslog message is displayed:

```
<Tue Apr 30 10:02:47 2019> ERROR!!! Standby Supervisor-4
(DS-X97-SF4-K9) could not come online...
```

**Solution** None. A retry attempt to bring up the Supervisor-4 Module is initiated by the switch every 15 minutes.

**Problem** The supervisor module fails to come online. The following syslogs are displayed:

```
<Tue Apr 30 10:02:47 2019> ERROR!!! Timeout waiting for Supervisor-4
(DS-X97-SF4-K9) to come online, aborting migration...
<Tue Apr 30 10:02:47 2019> Powering down Supervisor-4 (DS-X97-SF4-K9) in slot <slot_number>
```

**Solution** Use the migration command again.

**Problem** The Supervisor-1 Module image links are not restored on the active Supervisor-1 Module before the switchover to Supervisor-4 Module is initiated. The following syslogs are displayed before saving configuration:

```
<Tue Apr 30 10:02:47 2019> WARNING!!! Error resetting original Supervisor-3 (DS-X97-SF1-K9)
image links, continuing migration...
<Tue Apr 30 10:02:47 2019> WARNING!!! Please set the boot variables manually before inserting
back
Supervisor-3 (DS-X97-SF1-K9) in standby slot <slot_number>, continuing migration...
```

**Solution** Use the migration command again.

**Problem** The `copy r s` command fails on the active Supervisor-1 Module before the switchover to the Supervisor-4 Module is initiated. The following syslog is displayed:

```
<Tue Apr 30 10:02:47 2019> ERROR!!! Failed to save configuration, aborting migration...
```

**Solution** Use the migration command again.

**Problem** The switchover fails on the active Supervisor-1 Module before the switchover to the Supervisor-4 Module is initiated. The following syslog is displayed:

```
<Tue Apr 30 10:02:47 2019> ERROR !! Switchover failed, aborting migration...
```

**Solution** Use the migration command again.

**Problem** In case the Supervisor-4 Module is not inserted within 30 minutes after executing the migration command, the switch will try to power up the powered down Supervisor-1 Module in the standby slot on reaching the timeout of 30 minutes. If the standby Supervisor-1 Module fails to power up, the following syslog message is displayed before aborting migration:

```
<Tue Apr 30 10:02:47 2019> ERROR !!! Failed to power up Standby Supervisor,
Please power up manually using "no poweroff module <slot_num>" from config mode
```

**Solution** Use the `no poweroff module slot_number` configuration command on the active Supervisor-4 Module to bring up the powered down standby Supervisor-1 Module.

**Problem** Setting of the boot variable parameters fails after migration when the Supervisor-4 Module becomes active supervisor. The following syslog is displayed:

```
BOOTVAR-2-SUP_MIGRATION_CONFIG_ERROR
Setting boot parameters for supervisor migration process returned error.
Please set the boot variables manually using
'boot kickstart <kickstart_image>' and 'boot system <system_image>' and save configs"
```

**Solution** Use the `boot kickstart kickstart_image` and the `boot system system_image` configuration commands on the active Supervisor-4 Module when it becomes active after the migration has been completed.

**Problem** Migration fails on Supervisor-4 Module because of insufficient bootflash file space on the Supervisor-4 Module. The following syslog is displayed:

```
2019 Apr 2 08:47:43 switch %FS-STANDBY-DAEMON-2-FSD_ENOSPC_BOOTFLASH:
Due to insufficient space, system image could not be copied to standby bootflash.
system image is not present on standby. Please copy 'm9700-sf4ek9-mz.8.4.1.bin' manually.
Standby supervisor not yet online. This might take sometime. Please wait...
```

**Solution** Check the reason behind the insufficient space in the Supervisor-4 Module. After identifying the cause, delete sufficient files to free up enough space for the migration.

## Disruptive Migration from Supervisor-1/1E to Supervisor-4 Modules

To perform a disruptive migration from Supervisor-1/Supervisor-1E Modules to Supervisor-4 Modules, follow these steps:

**Before you begin**

Before migrating from a Supervisor-1/Supervisor-1E Module to a Supervisor-4 Module, note the following guidelines:

- You cannot mix Supervisor-1/Supervisor-1E Module and Supervisor-4 Module in a production environment.



**Note** In the following procedure, all show outputs, system messages, and image file names are displayed for the Cisco MDS 9710 Multilayer Director Switch. The show outputs, system messages, and image file names will vary based on the Cisco MDS 9700 Series Multilayer Director Switch selected.

**Procedure**

**Step 1** Insert a USB drive in the usb1 or the slot0 USB port on the active Supervisor-1 Module. We will use the usb1 port for the steps given below.

**Step 2** Format the drive by using the **format** command.

```
switch(config)# format usb1
```

**Step 3** Back up the running configuration from the current active supervisor module (DS-X97-SF1-K9) to the FTP/SFTP/TFTP server, or a USB flash drive.

```
switch# copy running-config
ftp://[username[:password]@]server[/path]
```

OR

```
switch# copy running-config usb1:runningconfiguration.txt
Copy complete, now saving to disk (please wait)...
```

**Note** runningconfiguration.txt is a filename variable.

**Step 4** Back up the installed licenses from the switch to a USB drive by using the copy licenses command. To view the current licenses installed on the switch, use the **show license** command.

```
switch# show license
license.lic:
SERVER this_host ANY
VENDOR cisco
INCREMENT ENTERPRISE_PKG cisco 1.0 permanent uncounted \
VENDOR_STRING=MDS HOSTID=VDH=REG070201 \
NOTICE="<LicFileID>ent_ips_main_fm.lic</LicFileID><LicLineID>0</LicLineI
D> \
<PAK>dummyPak</PAK>" SIGN=FB454F0A0D40
INCREMENT MAINFRAME_PKG cisco 1.0 permanent uncounted \
VENDOR_STRING=MDS HOSTID=VDH=REG070201 \
NOTICE="<LicFileID>ent_ips_main_fm.lic</LicFileID><LicLineID>1</LicLineI
D> \
<PAK>dummyPak</PAK>" SIGN=0DAE1B086D9E
INCREMENT SAN_EXTN_OVER_IP cisco 1.0 permanent 7 VENDOR_STRING=MDS \
HOSTID=VDH=REG070201 \
NOTICE="<LicFileID>ent_ips_main_fm.lic</LicFileID><LicLineID>2</LicLineI
D> \
<PAK>dummyPak</PAK>" SIGN=D336330C76A6
```



```
INCREMENT FM_SERVER_PKG cisco 1.0 permanent uncounted \
VENDOR_STRING=MDS HOSTID=VDH=REG070201 \
NOTICE="<LicFileID>ent_ips_main_fm.lic</LicFileID><LicLineID>3</LicLineI
D> \
<PAK>dummyPak</PAK>" SIGN=AEAEA04629E8
```

```
switch# copy licenses usb1:licenses_archive_file_name.tar
```

**Note** You must use the tar extension for the archive file. This file will contain all the license files that were installed on the Supervisor-1 Module.

**Step 5** Back up the outputs of the **show tech-support details** command, and redirect the file to a remote server using an FTP, TFTP, SFTP, SCP, or a USB flash drive.

```
switch# show tech-support details> scp://root@x.x.x.x/root/showtechsupport.txt
```

OR

```
switch# show tech-support details> usb1:showtechsupport.txt
```

**Step 6** Physically turn off the power to the switch, using the power switch, on each of the power supplies. The Output LED turns **off** on each power supply and the Status LEDs turn **off** on all the supervisor and I/O modules.

**Caution** If any of the supervisor or I/O module Status LEDs is turned on (showing any color), stop at this step until you are able to turn off those modules.

**Step 7** For each Supervisor-1 Module installed in the switch, remove the module and replace it with a Supervisor-4 Module as explained in [Installing a Supervisor Module, on page 115](#) and [Removing a Supervisor Module, on page 117](#).

**Caution** If the switch has two supervisor modules, ensure that both the supervisors are of the same type. Do not mix Supervisor-1 Module with Supervisor-4 Modules.

**Step 8** Power up the switch, using the power switch, on each of its power supplies. The Output LED on each power supply turns **on** and eventually turns green when the power supply is sending power to the switch. The Status LED on each installed supervisor module also turns on when the module begins to turn on. The supervisor that becomes active has a green ACTIVE LED (the standby supervisor module has an amber ACTIVE LED).

**Step 9** Remove the USB drive from the Supervisor-1 Module (this drive has copies of the Supervisor-1 Module configuration, license, and software images) and insert it in the USB port on the active Supervisor-4 Module (ACTIVE LED is green).

**Step 10** Connect a console to the active supervisor module as explained in [Connecting a Console to the Switch](#).

**Step 11** If you are setting up the initial configuration for the supervisor module, the initial setup script will ask you if you want to enforce the secure password standard. Make your selection, enter your password, and then confirm the password by entering it again.

```
---- System Admin Account Setup ----
Do you want to enforce secure password standard (yes/no) [y]:
Enter the password for "admin":
Enter the password for "admin":
```

**Step 12** When you are asked to enter the basic configuration, enter **no**.

```
---- Basic System Configuration Dialog VDC: 1 ----
This setup utility will guide you through the basic configuration of the system. Setup configures
only enough connectivity for management of the system.
Please register Cisco Nexus7000 Family devices promptly with your supplier. Failure to register may
affect response times for initial service calls. Nexus7000 devices must be registered to receive
entitled support services.
Press Enter at anytime to skip a dialog. Use ctrl-c at anytime
to skip the remaining dialogs.
Would you like to enter the basic configuration dialog (yes/no): no
```

**Step 13** When asked to log in, enter the login and password that you specified in step [Step 11, on page 155](#).

```
User Access Verification
switch login:
Password:
```

**Step 14** Verify that the switch is running the required version of the Cisco MDS NX-OS software by using the **show version** command.

```
switch(config)# show version
```

**Note** If the version of the Cisco MDS NX-OS is not the same as you intended to use, perform an upgrade to the appropriate version. To upgrade an image version on the switch, refer to the respective [Upgrade and Downgrade](#) guides.

**Step 15** Reinstall the license files on the new Supervisor-4 Module.

```
switch(config)# copy usb1:licenses_archive_file_name.tar bootflash:switch_license.tar
```

```
Copy progress 100% 10KB
Copy complete, now saving to disk (please wait)...
```

```
switch(config)# copy bootflash:switch_license.tar bootflash:switch_license.lic
```

```
Copy progress 100% 10KB
Copy complete, now saving to disk (please wait)...
```

```
switch(config)# install license bootflash:switch_license.lic
```

```
Installing license.....done
```

```
switch# show license usage
```

Feature	Ins	Lic Count	Status	Expiry Date	Comments
IOA_X9334	No	0	In use		Grace 115D 2H
FM_SERVER_PKG	No	-	Unused		-
MAINFRAME_PKG	No	-	Unused		-
ENTERPRISE_PKG	Yes	-	Unused	never	-
SAN_ANALYTICS_PKG	No	-	In use		Grace 119D 20H
SAN_TELEMETRY_PKG	No	-	Unused		Grace 109D 1H

**Step 16** Make sure that all I/O modules are online and that the standby supervisor is in HA-standby mode by using the **show module** command.

The following is a sample output for the **show module** command on the Supervisor-4 Module:

```
switch# show module
```

```
Mod Ports Module-Type Model Status
-----
1 48 4/8/16/32 Gbps Advanced FC Module DS-X9648-1536K9 ok
2 48 2/4/8/10/16 Gbps Advanced FC Module DS-X9448-768K9 ok
5 0 Supervisor Module-4 DS-X97-SF4-K9 ha-standby
6 0 Supervisor Module-4 DS-X97-SF4-K9 active *
7 24 40 Gbps FCoE Module DS-X9824-960K9 ok
8 48 1/10 Gbps Ethernet Module DS-X9848-480K9 ok
9 48 1/10 Gbps Ethernet Module DS-X9848-480K9 ok
```

```
Mod Sw Hw
```

```
-----
1 8.4(1) 1.0
```

```

2 8.4(1) 2.0
5 8.4(1) 1.0
6 8.4(1) 1.0
7 8.4(1) 1.0
8 8.4(1) 1.1
9 8.4(1) 1.1

```

```

Mod  MAC-Address (es)                               Serial-Num
---  -
1    78-ba-f9-c4-c9-88 to 78-ba-f9-c4-c9-8b    JAE192008R8
2    f0-78-16-c6-20-6c to f0-78-16-c6-20-6f    JAE192008S9
3    f0-78-16-c6-73-6c to f0-78-16-c6-73-6f    JAE192901GT
4    1c-df-0f-78-4e-88 to 1c-df-0f-78-4e-8b    JAE170407ZK
5    00-b8-b3-ee-60-bc to 00-b8-b3-ee-60-cf    JAE22350LYE
6    00-b8-b3-ee-67-d8 to 00-b8-b3-ee-67-eb    JAE22350LY2
7    80-e8-6f-f8-1a-84 to 80-e8-6f-f8-1a-87    JAE192901GS
8    28-52-61-d6-30-20 to 28-52-61-d6-30-54    JAE204207SM
10   00-d6-fe-b1-c0-aa to 00-d6-fe-b1-c0-de    JAE2234039S

```

```

Mod  Online Diag Status
---  -
1    Pass
2    Pass
3    Pass
4    Pass
5    Pass
6    Pass
7    Pass
8    Pass
10   Pass

```

```

Xbar  Ports  Module-Type                               Model                               Status
---  -
1     0      Fabric module 1                            DS-X9710-FAB1                       ok
2     0      Fabric module 1                            DS-X9710-FAB1                       ok
3     0      Fabric module 1                            DS-X9710-FAB1                       ok
4     0      Fabric Module 1                            DS-X9710-FAB1 ok                     ok
5     0      Fabric module 1                            DS-X9710-FAB1                       ok
6     0      Fabric module 1                            DS-X9710-FAB1                       ok

```

```

Xbar  Sw          Hw
---  -
1     NA         1.0
2     NA         1.0
3     NA         1.0
4     NA         1.0
5     NA         1.0
6     NA         1.0

```

```

Xbar  MAC-Address (es)                               Serial-Num
---  -
1     NA         JAE1644063E
2     NA         JAE1644063I
3     NA         JAE16410AS2
4     NA         JAE182408ZW
5     NA         JAE1644061K
6     NA         JAE1710088N

```

**Step 17**

Restore the previously saved configurations by using the **copy** command to copy the configuration file in the USB drive to the running configuration.

```
switch(config)# copy usb1:configuration_file_name running-config
```

**Note** If you have not inserted the standby supervisor module until now, do not insert it during this step. Instead, wait until you complete this procedure before installing the standby supervisor module.

**Step 18** Save the configuration in the startup configuration by using the **copy running-config startup-config** command.

```
switch(config)# copy running-config startup-config
```

## Installing a Switching Module

To install a switching module in the chassis, follow these steps:

### Before you begin



**Note** When inserting a new line card into a slot, ensure the new line card is of the same model as the existing line card. If there is a mismatch in the line card models, the line card configurations are removed from the configuration file.

### Procedure

- Step 1** Before installing any modules in the chassis, we recommend installing the chassis in the rack. See the [“Installing the Cisco MDS 9700 Series Switch on a Four-Post Rack or Cabinet”](#) section.
- Step 2** Before installing any switching modules, install at least one supervisor module.
- Step 3** Choose a slot for the module and verify that there is enough clearance to accommodate any cables or interface equipment that you want to connect to the module. If possible, place modules between empty slots that contain filler panels.
- Step 4** Verify that the captive screws are tightened to 8 in-lb on all modules already installed in the chassis. This ensures that the EMI gaskets are fully compressed and maximizes the opening space for the module being installed.
- Step 5** If a filler panel is installed, remove the two Phillips pan-head screws from the filler panel and remove the panel. To remove a currently installed module, see [Removing a Switching Module](#).
- Step 6** Press line card ejector buttons to open both side levers to fully open position.
- Step 7** Position the module in the chassis as follows:
- Align the line card into the chassis card cage slots and push it in slowly. We recommend to push the center of line card faceplate to push the line card in.
  - Continue to push in the line card slowly into the chassis until its rear connectors touch the mid-plane surface and both ejector levers swing inward about 25 degrees. This indicates that both the ejector lever jaws are now inside the chassis jaw cutouts and the card is ready to close the ejector levers.
  - Once visually confirmed that both ejector levers are swung inward about 25 degrees, push in both ejector levers simultaneously to fully insert the line card into the chassis until they are in a mechanically locked position. Both ejector levers should be parallel to the line card faceplate when locked.

**Note** Ensure that the ejector levers are fully closed before tightening the captive screws. Failure to fully seat the module in the backplane connector can result in error messages.

- d. Tighten the two captive screws on the supervisor module or switching module to 8 in-lb.

---

**What to do next**

Follow these steps if the installation is for a replacement module, not a new installation:

1. Perform a module configuration purge if the new module is different from the older module.  
Use the command `purge module x running-config`, replace `x` with the slot number of replaced module.
2. Bring up (no shut) the ports, if any, that were shut down when the old module was replaced.

## Removing a Switching Module

You can remove one of these modules at a time while the switch is operating. To remove a switching module from the chassis, follow these steps:

**Before you begin**

You need a flat-blade or number 2 Phillips-head screwdriver to loosen or tighten the captive screws on the switching module.

**Procedure**

- 
- Step 1** Shutdown all ports in state up to minimize frame loss.
  - Step 2** Disconnect any network interface cables attached to the module.
  - Step 3** Loosen the two captive screws on the module being removed.
  - Step 4** Press ejector release buttons on the left and right ends of the module to push out the ejector levers and to disconnect the module.
  - Step 5** Simultaneously rotate the two ejector levers outward to unseat the module from the mid-plane connector.
  - Step 6** With a hand on each ejector, pull the module part way out of its slot in the chassis.
  - Step 7** Grasp the front edge of the module and slide the module partially out of the slot. Place your other hand under the module to support the weight of the module. Do not touch the module circuitry.
  - Step 8** Place the module on an antistatic mat or antistatic foam, or immediately reinstall it in another slot.
  - Step 9** If the slot will remain empty, install a filler panel to keep the chassis dust-free and to maintain proper airflow through the chassis.
- 

## Verifying Installation of the Supervisor and Switching Modules

To verify the module installation, follow these steps:

## Procedure

- 
- Step 1** Verify that the ejector levers of each module are fully closed (parallel to the front of the module) to ensure that the supervisor module and all switching or services modules are fully seated in the backplane connectors.
- Step 2** Check the captive screws of each module, the power supply, and the fan module. Tighten any loose captive screws to 8 in-lb.
- Step 3** Verify that any empty module slots have filler panels installed and that the screws holding the panels in place are tight.
- Step 4** Turn on the power supply switches to power up the system and check the LEDs on the modules.

For information about how to check connectivity of modules, see the *Cisco MDS 9000 Family NX-OS Fundamentals Configuration Guide*.

---

# Crossbar Fabric Switching Modules

## Guidelines for Crossbar Fabric Switching Module Installation

The following table lists the recommended slots for the crossbar fabric switching modules in a Cisco MDS 9700 Series chassis, based on the total number of crossbar fabric switching modules in a chassis:

Number of Crossbar Fabric Switching Modules	Slots Number
2	1 and 2
3	1, 3, and 5
4	1, 2, 3, and 5
5	1, 2, 3, 4, and 5
6	1, 2, 3, 4, 5, and 6



---

**Note** In a Cisco MDS 9700 chassis with Cisco MDS 9000 24/10-Port SAN Extension Module (DS-X9334-K9), the chassis must have at least one online crossbar fabric switching module in the slots 1 to 5 at any point of time.

---



---

**Note** In a Cisco MDS 9700 chassis with Cisco MDS 9000 24/10-Port SAN Extension Module (DS-X9334-K9), if crossbar (xbar) fabric switching modules 5 and 6 are online, and you want to power down or replace module 6 nondisruptively, you have to power down/out-of-service xbar module 5 first, followed by power down/out-of-service and replace the xbar module 6.

---

## Installing a Crossbar Fabric Switching Module

To install a crossbar fabric switching module in the Cisco MDS 9700 Series switch, follow these steps:

### Before you begin

- You must follow ESD protocols, including the following:
  - You must wear a grounded ESD wristband (or other personal grounding device) whenever you handle the electronic modules outside the grounded chassis.
  - You must carry electronic modules by only their covered edges or handles. Do not touch their electronic components.
  - Whenever a module is outside a grounded chassis, place it flat on an antistatic surface or in an antistatic bag. Never lean the module on anything nor place anything else on top of the module nor lean anything on the module.
- Verify that the chassis is grounded.
- Verify that you have the following tools and equipment:
  - ESD wrist strap (or other personal grounding device)
  - Number 1 Phillips torque screwdriver
  - Manual torque screwdrivers are recommended. Be sure to never exceed the recommended torque setting for the screw that you are working with.
- Ensure that sufficient quantity of Cisco MDS Crossbar Fabric-3 Switching Modules (6 modules are supported in a Cisco MDS 9000 Series Multilayer Director) are available for replacing the current Cisco MDS Crossbar Fabric Switching Modules in the switch.



### Warning

It is not supported to mix different crossbar fabric switching modules (Crossbar Fabric-1 Switching Module and Crossbar Fabric-3 Switching Module) outside a maintenance window. This mix of modules is supported only while you are migrating from Fabric-1 modules to Fabric-3 modules. After a reboot of the switch, if there is a mix of Fabric-1 and Fabric-3 modules, only the Fabric-3 modules will be powered on.



### Warning

Ensure that there is no loose debris (such as paper, ties, dust) around the back of the chassis when the crossbar switching modules are being removed. When the crossbar switching modules are pulled, the vacuum created can be strong enough to pull the loose debris into the chassis.

## Procedure

- Step 1** Shut down the crossbar fabric switching module to be replaced by using the **out-of-service xbar slot** command (where, *slot* refers to the external crossbar fabric switching module slot number).

**Step 2** Remove the fan module that is over the crossbar fabric switching module to be removed. For more information on how to remove a fan module, see [Installing and Removing Fan Modules or Trays, on page 180](#). Crossbar fabric switching modules are numbered 1-6, from left to right, when facing the rear of the chassis. If the system is running, remove only one fan module at a time to access the required crossbar fabric switching module.

The positioning of the fan modules and respective crossbar fabric switching modules is as follows:

Fan module 1	Fabric modules 1-2
Fan module 2	Fabric modules 3-4
Fan module 3	Fabric modules 5-6

**Step 3** To open a fabric slot for the new fabric module, remove a fabric module as follows:

- a. With your face at least 12 inches (30 cm) away from the front of the fabric module, press both eject buttons on the front of the module (see Callout 1 in the following figure).

**Caution** Keep your face away from the front of the fabric module so that the levers do not hit your face when they spring out from the front of the module.

**Figure 48: Unlocking a Fabric Module from its Slot**

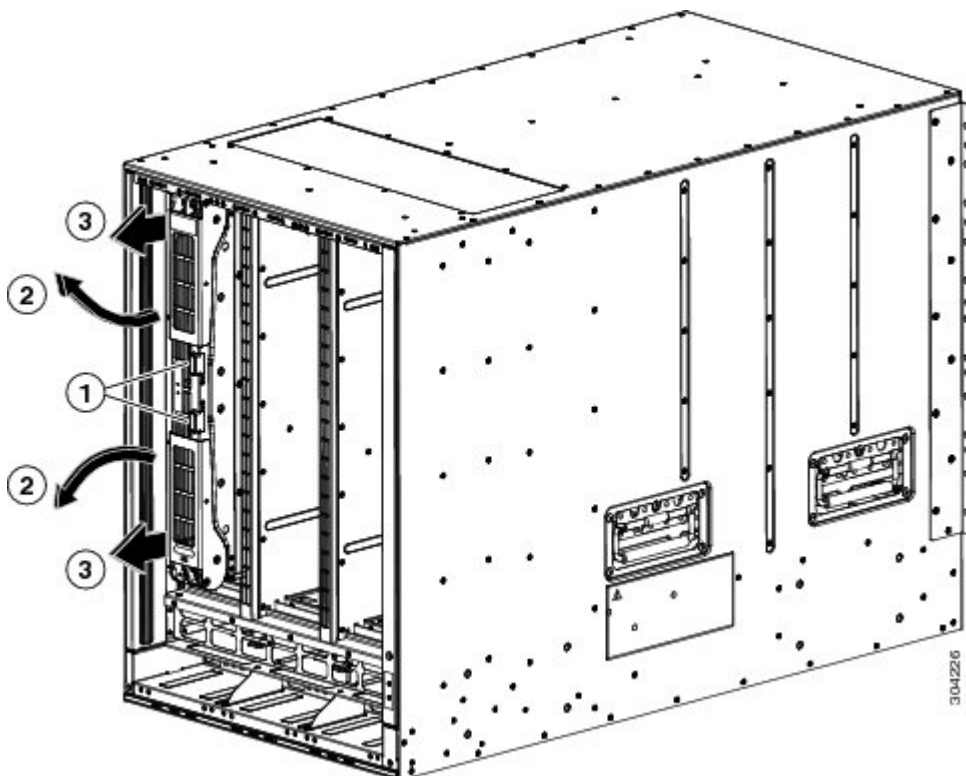

1	Press both eject buttons.	2	Handles spring out from the module.
---	---------------------------	---	-------------------------------------



3	Pull the handles to partially remove the module from the slot.		
---	--	--	--

- b. Grasp each of the two levers with your two hands and fully rotate the levers out 90 degrees from the fabric module.
- c. Pull both levers until the fabric module is about 3 inches (7 cm) out of the chassis (see Callout 3 in the previous figure).
- d. Rotate both levers back to the front of the module (see Callout 1 in the following figure).

Each lever clicks when it locks in place at the front of the module.

**Figure 49: Removing the Fabric Module from its Slot**

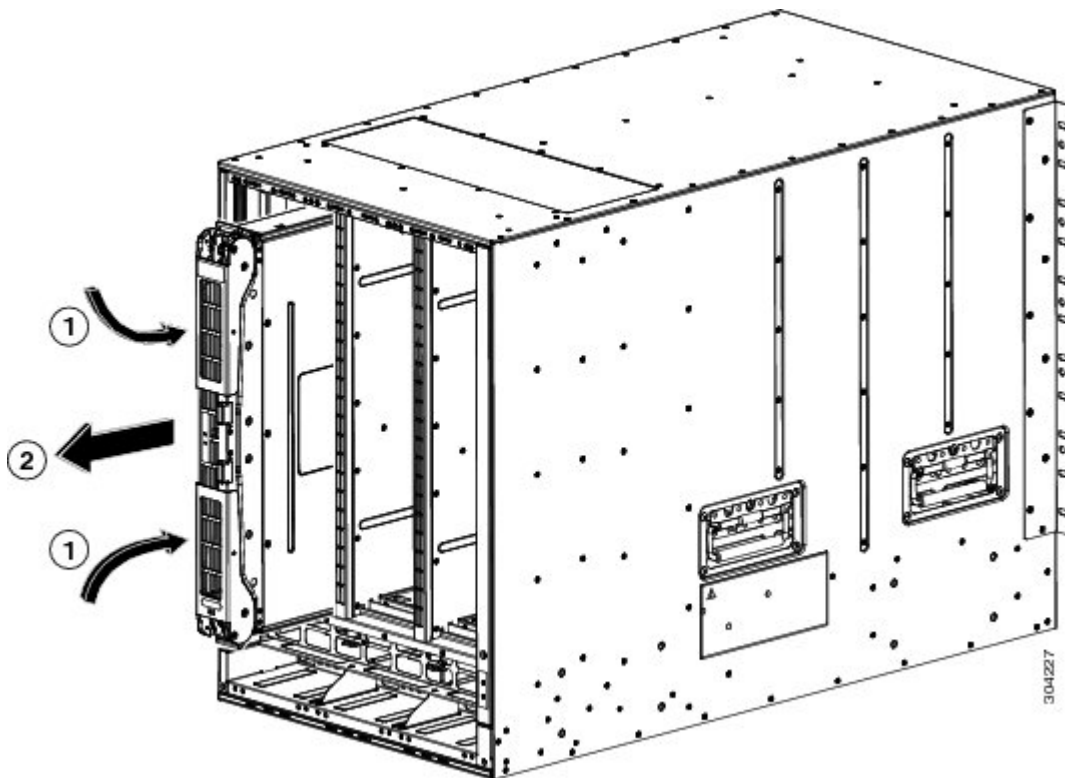

1	Rotate both levers to the front of the module until they click.	2	Pull the module out of the slot.
---	---	---	----------------------------------

- e. Grasp the front of the module with one hand, place the other hand under the module to support its weight, and pull the module out of the slot (see Callout 2 in the previous figure).

**Caution** Be careful not to touch any electrical contacts on the back of the module. Handle only covered sides or edges of the module.

- f. Place the module on an antistatic surface or inside an antistatic bag.

**Step 4** Install the new fabric module in the chassis as follows:

- a. Hold the front of the new module with one hand and place the other hand under the module.

- b. Rotate the module clockwise and align the back of the module to the module guides at the top and bottom of the open fabric slot in the chassis.
- c. Push the module half way into the slot (see the following figure).

**Figure 50: Inserting the Fabric Module into the Chassis**

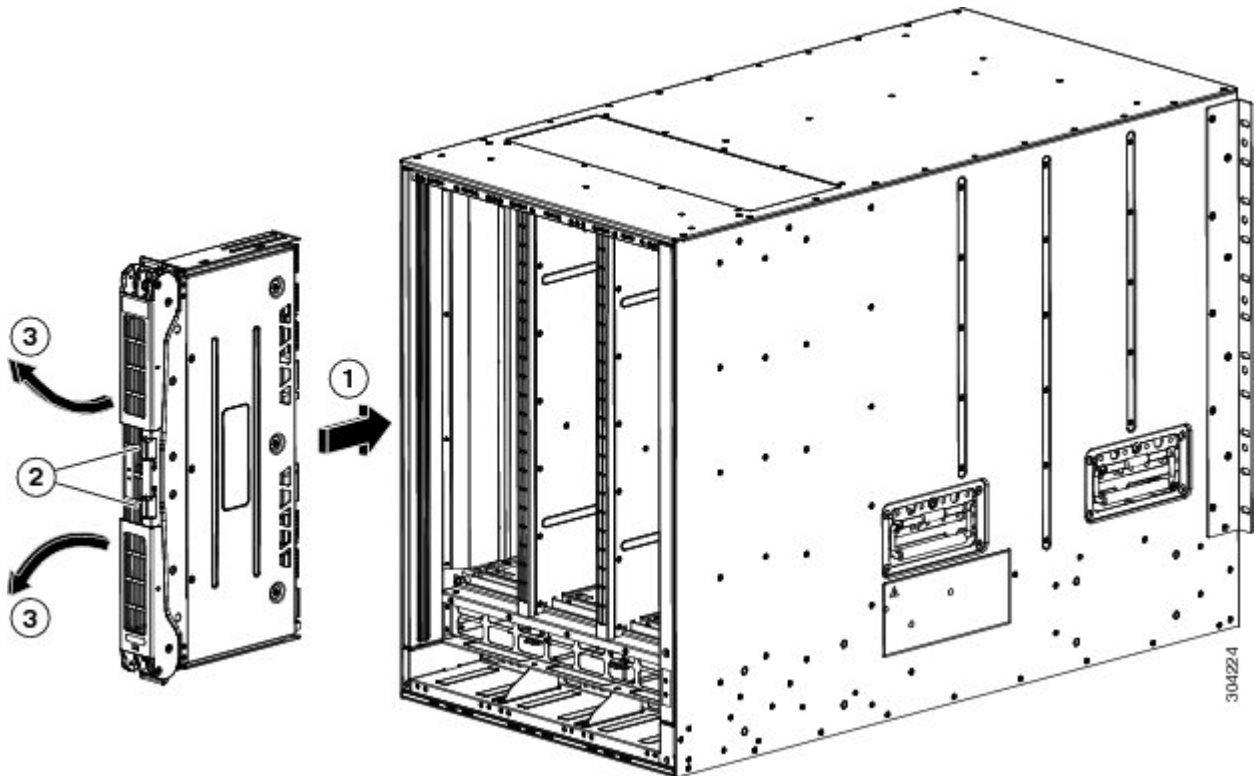

1	Align the module with the guides in the open slot and push the module half way into the slot.
2	Press both eject buttons.
3	Handles spring out from the module.

- d. With your face away from the fabric module, press both ejector buttons on the front of the module.

**Caution** Keep your face at least 12 inches (30 cm) from the front of the fabric module so that the ejector handles do not hit your face when they spring out from the front of the module.

Both ejector handles spring out from the front of the module (see Callout 2 in the previous figure).

- e. Grasp both handles, fully rotate the levers 90 degrees from the front of the module, and push the module all the way into the slot until it seats.

The front of the module will be about 1/4 inch out from the installed fabric modules.

- f. Simultaneously rotate both handles to the front of the module while pressing the module further into the slot (see Callout 1 in the following figure).

The handles click when fully rotated to the front of the module.

Figure 51: Securing the Fabric Module to the Slot

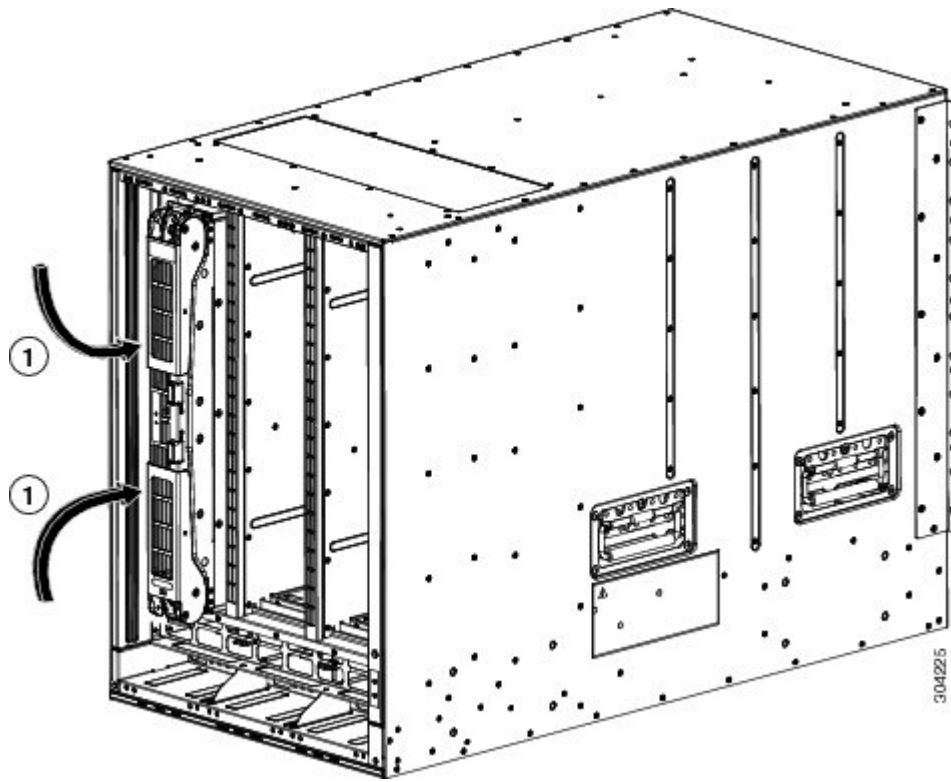

- |   |   |
|---|---|
| 1 | Rotate the handles to the front of the module until they click. |
|---|---|

- g. Verify that the module is secured to the chassis and that you cannot remove it without pressing the eject buttons.

- Step 5** Reinstall the fan module over the installed fabric module. For more information on how to install a fan module, see [Installing and Removing Fan Modules](#).
- Step 6** Verify that the Fan Status LED is green. If the LED is not green, one or more fans are faulty. If this occurs, contact your customer service representative for a replacement part.
- Step 7** Wait till the first replaced module is up, follow the same procedure for all the remaining fabric modules. Perform this task sequentially for all the modules (1,2, 3, 4, 5 and 6). Perform [Step 1](#) to [Step 6](#) for the other modules. The new inserted fabric modules will come up.

## Removing a Crossbar Fabric Switching Module

To remove a crossbar module from the Cisco MDS 9700 Series switch without compromising the integrity and availability of SANs, follow these steps:

## Procedure

- 
- Step 1** Shut down the crossbar fabric module by using the out-of-service xbar slot command (where slot refers to the external crossbar fabric module slot number).
- Step 2** Remove the fan module that is over the crossbar fabric module to be removed. For more information on how to remove a fan module, see [Installing and Removing Fan Modules or Trays, on page 180](#).
- Step 3** Press ejector release buttons located at the center of the crossbar module to push out the ejector levers and to disconnect the module from the backplane.
- Caution** You must be cautious when the ejector levers swing open and stay open during installation and removal process.
- Step 4** With a hand on each ejector, pull the module part way out of its slot in the chassis.
- Step 5** Grasp the front edge of the module and slide the module partially out of the slot. Place your other hand under the module to support the weight of the module. Do not touch the module circuitry.
- Step 6** Place the module on an antistatic mat or antistatic foam, or immediately reinstall it in another slot.
- 

# Nondisruptive Migration from Crossbar Fabric-1 Switching Modules to Crossbar Fabric-3 Switching Modules

This section describes the steps required to migrate all the Crossbar (XBAR) Fabric-1 Switching Modules to Crossbar Fabric-3 Switching Modules for the Cisco MDS 9000 Series Multilayer Directors.

This topic includes the following sections:



---

**Note** Before you install, operate, or service the system, read the *Regulatory Compliance and Safety Information for the Cisco MDS 9000 Family* for important safety information.

---

## Requirements

We recommend that you have knowledge of the Cisco NX-OS operating system CLI.

## Components Used

The information in this document is based on the following software and hardware versions:

- Cisco MDS 9718 Multilayer Director (DS-C9718) with Cisco MDS NX-OS Release 8.4(2a). Cisco MDS 9710 Multilayer Director (DS-C9710), or a Cisco MDS 9706 Multilayer Director (DS-C9706) with Cisco MDS NX-OS Release 8.4(1)
- Cisco MDS 9718 Crossbar Fabric-3 Switching Module (DS-X9718-FAB3) and Cisco MDS 9718 Crossbar Fabric-1 Switching Module (DS-X9718-FAB1)

- Cisco MDS 9710 Crossbar Fabric-3 Switching Module (DS-X9710-FAB3). For Cisco MDS 9706 Multilayer Director (DS-C9706), it is Cisco MDS 9706 Crossbar Fabric-3 Switching Module (DS-X9706-FAB3).
- Cisco MDS 9710 Crossbar Fabric-1 Switching Module (DS-X9710-FAB1). For Cisco MDS 9706 Multilayer Director (DS-C9706), it is Cisco MDS 9706 Crossbar Fabric-1 Switching Module (DS-X9706-FAB1)

## Prerequisites

- Ensure that the switch (Cisco MDS 9710 and Cisco MDS 9706 Multilayer Director Switch) has software release version Cisco MDS NX-OS Release 8.4(1) or later. On Cisco MDS 9718 Multilayer Director Switch, ensure that the switch is running on Cisco MDS NX-OS Release 8.4(2a) or later.

To upgrade an image version on the switch, refer the [Cisco MDS 9000 NX-OS Software Upgrade and Downgrade Guide, Release 8.x](#) guide.

- When an MDS 9718, 9710, or 9706 chassis has 6 x Crossbar Fabric-1 Switching Modules installed, you must migrate a minimum of 3 x Crossbar Fabric-1 Switching Modules to Crossbar Fabric-3 Switching Modules, and remove the remaining 3 x Crossbar Fabric-1 Switching Modules to support full bandwidth to 32-Gbps fiber channel switching modules.
- You must follow ESD protocols, including the following:
  - You must wear a grounded ESD wristband (or other personal grounding device) whenever you handle the electronic modules outside the grounded chassis.
  - You must carry electronic modules by only their covered edges or handles. Do not touch their electronic components.
  - Whenever a module is outside a grounded chassis, place it flat on an antistatic surface or in an antistatic bag. Never lean the module on anything nor place anything else on top of the module nor lean anything on the module.
- Verify that the chassis is grounded.
- Verify that you have the following tools and equipment:
  - ESD wrist strap (or other personal grounding device)
  - Number 1 Phillips torque screwdriver
  - Manual torque screwdrivers are recommended. Be sure to never exceed the recommended torque setting for the screw that you are working with.
- Ensure that sufficient quantity of Cisco MDS Crossbar Fabric-3 Switching Modules (6 modules are supported in a Cisco MDS 9718, Cisco MDS 9710, or 9706 Multilayer Director) are available for replacing the current Cisco MDS Crossbar Fabric-1 Switching Modules in the switch.
- Perform the Fabric-1 to Fabric-3 module migration after the Supervisor-1/Supervisor-1E to Supervisor-4 Module migration is completed. A mix of Fabric-1 with Supervisor-4 Modules or Fabric-3 with Supervisor-1/Supervisor-1E Modules is supported during migration only.

**Warning**

Mix of different crossbar fabric switching modules (Crossbar Fabric-1 Switching Module and Crossbar Fabric-3 Switching Module) outside a maintenance window, is not supported. This mix of modules is supported only while you are migrating from Crossbar Fabric-1 Switching Modules to Crossbar Fabric-3 Switching Modules. After a reboot of the switch, if there is a mix of Crossbar Fabric-1 Switching Modules and Crossbar Fabric-3 Switching Modules, only the Crossbar Fabric-3 Switching Modules will be powered on.

## Performing a Nondisruptive Migration from Crossbar Fabric-1 Switching Modules to Crossbar Fabric-3 Switching Modules

To migrate a Crossbar Fabric-1 Switching Modules to Crossbar Fabric-3 Switching Modules, follow these steps:

**Before you begin**

The migration process should be performed during schedule maintenance period only.

**Note**

Backward migration procedure (migrating from Cisco MDS 9000 Crossbar Fabric-3 Switching Module to Crossbar Fabric-1 Switching Module) will be disruptive.

**Note**

Perform the Crossbar Fabric-1 Switching Module to Crossbar Fabric-3 Switching Module migration after the Supervisor-1/Supervisor-1E to Supervisor-4 Module migration is completed. A mix mode of Crossbar Fabric-1 Switching Modules with Supervisor-4 Modules and Crossbar Fabric-3 Switching Modules with Supervisor-1/Supervisor-1E Modules is not supported.

**Note**

Once the crossbar fabric switching modules migration process is initiated, wait for the migration process to complete, do not abort the process midway.

## Procedure

	Command or Action	Purpose						
<b>Step 1</b>	Shut down the crossbar fabric switching module by using the <b>out-of-service xbar slot</b> command (where slot refers to the external crossbar fabric switching module slot number).	<b>Note</b> If the Crossbar Fabric-1 Switching Modules are not installed in the recommended slots, when you migrate to the Crossbar Fabric-3 Switching Modules, install the new modules in the recommended slots as described in the <a href="#">Guidelines for Crossbar Fabric Switching Module Installation</a> , section. For example, if you are migrating the Crossbar Fabric-1 Switching Modules from the slots 1, 2, 3 and 4, insert the Crossbar Fabric-3 Switching Modules in slots 1, 2, 3, and 5.						
<b>Step 2</b>	Remove the fan module that is over the crossbar fabric switching module to be removed. Fan modules 1 to 3 are numbered left to the right. When the fan modules are installed, they cover the crossbar fabric switching modules.	<p>Crossbar fabric switching modules are numbered 1-6, from left to right, when facing the rear of the chassis. If the system is running, remove only one fan module at a time to access the required crossbar fabric switching module. You can use the <b>locator-led xbar xbar-number</b> command to turn on the locator LED to assist in the fabric module identification. The positioning of the fan modules and respective crossbar fabric switching modules is as follows:</p> <p>For more information on how to remove a fan module, see <a href="#">Removing a Fan Module</a>.</p> <table border="1"> <tbody> <tr> <td>Fan module 1</td> <td>Fabric modules 1-2</td> </tr> <tr> <td>Fan module 2</td> <td>Fabric modules 3-4</td> </tr> <tr> <td>Fan module 3</td> <td>Fabric modules 5-6</td> </tr> </tbody> </table>	Fan module 1	Fabric modules 1-2	Fan module 2	Fabric modules 3-4	Fan module 3	Fabric modules 5-6
Fan module 1	Fabric modules 1-2							
Fan module 2	Fabric modules 3-4							
Fan module 3	Fabric modules 5-6							
<b>Step 3</b>	Remove the Crossbar Fabric-1 Switching Module from the chassis and replace it with the Crossbar Fabric-3 Switching Module. Once the new module is inserted, it will automatically power up.	<p><b>Note</b> Only one crossbar fabric switching module should be removed at a time. Before removing the second crossbar fabric switching module, ensure that the first module is up.</p> <p>For more information on how to remove and install a crossbar fabric switching module, see <a href="#">Crossbar Fabric Switching Modules, on page 160</a>.</p>						
<b>Step 4</b>	Reinstall the fan module that you removed in <a href="#">Step 2</a> . For more information on how to install a fan module, see <a href="#">Installing a Fan Module</a> .							
<b>Step 5</b>	Verify the fan status using the command <b>show environment fan</b> . Ensure the fan status is 'OK' before proceeding.							

	Command or Action	Purpose
<b>Step 6</b>	<p>Wait till the first replaced crossbar fabric switching module is up, follow the same procedure for all the remaining crossbar fabric switching modules. Ensure that the temperature of the chassis is normal, after each crossbar fabric module replacement. Use the <b>show environment temperature</b> command to view the current temperature. Perform this task sequentially for all the modules (1,2, 3, 4, 5 and 6). Perform <a href="#">Step 1</a> to <a href="#">Step 4</a> for the other modules. The latest inserted crossbar fabric switching modules will come up.</p>	<p><b>Note</b> If a Crossbar Fabric-3 Switching Module migration fails, we recommend that you continue the migration process with the remaining other Crossbar Fabric-3 Switching Modules. Ensure to replace the faulty Crossbar Fabric-3 Switching Module immediately with a new one to achieve full line rate bandwidth.</p> <p>The following example lists the sequence to replace the Crossbar Fabric-1 Switching Modules with the Crossbar Fabric-3 Switching Modules, when the existing modules are not in the recommended slots:</p> <pre>switch# show module xbar</pre> <pre>Xbar Ports  Module-Type Model                               Status ----- ----- 1      0      Fabric Module 1 DS-X9710-FAB1      ok 2      0      Fabric Module 1 DS-X9710-FAB1      ok 3      0      Fabric Module 1 DS-X9710-FAB1      ok 4      0      Fabric Module 1 DS-X9710-FAB1      ok</pre> <ol style="list-style-type: none"> <li>a. Shut down the Crossbar Fabric-1 Switching Module in slot 1, using the <b>out-of-service xbar slot</b> command.</li> <li>b. Remove the fan module 1 over the Crossbar Fabric-1 Switching Modules in slots 1-2.</li> <li>c. Physically remove and replace the Crossbar Fabric-1 Switching Module in slot 1 with a Crossbar Fabric-3 Switching Module.</li> <li>d. Install the fan module 1 over the crossbar fabric switching modules in slots 1-2.</li> <li>e. Verify the fan status using the command <b>show environment fan</b>. Ensure the fan status is 'OK' before proceeding.</li> <li>f. Follow Step a. to Step d. to replace the Crossbar Fabric-1 Switching Module in slot 2.</li> <li>g. Shut down the Crossbar Fabric-1 Switching Module in slot 3, using the <b>out-of-service xbar slot</b> command.</li> <li>h. Remove the fan module 2 over the Crossbar Fabric-1 Switching Modules in slots 3-4.</li> <li>i. Physically remove and replace the Crossbar Fabric-1 Switching Module in slot 3 with a Crossbar Fabric-3 Switching Module.</li> </ol>



	Command or Action	Purpose
		<ul style="list-style-type: none"> <li><b>j.</b> Install the fan module 2 over the crossbar fabric switching modules in slots 3-4.</li> <li><b>k.</b> Follow <a href="#">Step f</a> to <a href="#">Step i</a> to replace the Crossbar Fabric-1 Switching Module in slot 4.</li> <li><b>l.</b> Shut down the Crossbar Fabric-1 Switching Module in slot 5, using the <b>out-of-service xbar slot</b> command.</li> <li><b>m.</b> Remove the fan module 3 over the Crossbar Fabric-1 Switching Modules in slots 5-6.</li> <li><b>n.</b> Physically remove and replace the Crossbar Fabric-1 Switching Module in slot 5 with a Crossbar Fabric-3 Switching Module.</li> <li><b>o.</b> Install the fan module 3 over the crossbar fabric switching modules in slots 5-6.</li> <li><b>p.</b> Follow <a href="#">Step k</a> to <a href="#">Step n</a> to replace the Crossbar Fabric-1 Switching Module in slot 2.</li> </ul>

## Verification

Use the **show module xbar** command to verify the module type and module status.

```
switch# show module xbar
```

```

Xbar Ports  Module-Type                               Model                               Status
----
1      0      Fabric Module 3   DS-X9710-FAB3   ok
2      0      Fabric Module 3   DS-X9710-FAB3   ok
3      0      Fabric Module 3   DS-X9710-FAB3   ok
4      0      Fabric Module 3   DS-X9710-FAB3   ok
5      0      Fabric Module 3   DS-X9710-FAB3   ok
6      0      Fabric Module 3   DS-X9710-FAB3   ok

```

```

Xbar Sw           Hw
----
1      NA              1.0
2      NA              1.0
3      NA              1.0
4      NA              1.0
5      NA              1.0
6      NA              1.0

```

```

Xbar MAC-Address(es)                               Serial-Num
----
1      NA                                               JAE1710088N
2      NA                                               JAE2217096Y
3      NA                                               JAE222305V1
4      NA                                               JAE222305VE
5      NA                                               JAE222305V9
6      NA                                               JAE222305V8

```

To view the inventory information for modules from the Cisco DCNM Web UI, Choose **Inventory > View > Modules**. The **Modules** window is displayed with a list of all the switches and its details for a selected scope.

For more information, see the *Cisco DCNM SAN Management Configuration Guide*.

## Recovery Procedure

This section describes the steps needed to downgrade from Crossbar Fabric-3 Switching Modules to Crossbar Fabric-1 Switching Modules if there are issues with the Crossbar Fabric-3 Switching Modules upgrade.

### Scenario 1

If a chassis is running in a mixed mode (both Crossbar Fabric-1 Switching Modules and Crossbar Fabric-3 Switching Modules in **OK** state), then reverse the installation process and replace the Crossbar Fabric-3 Switching Modules one-by-one with Crossbar Fabric-1 Switching Modules. As long as at least one Crossbar Fabric-1 Switching Module is online, replacing Crossbar Fabric-3 Switching Modules with Crossbar Fabric-1 Switching Modules can be done nondisruptively. Do not remove any further Crossbar Fabric-1 Switching Modules. If all the Crossbar Fabric-1 Switching Modules are removed or are in powered down state, then the downgrade will be disruptive.

### Scenario 2

If a chassis is loaded with all six Crossbar Fabric-3 Switching Modules, then reinstalling the Crossbar Fabric-1 Switching Modules will be disruptive. Power down the switch and manually replace the Crossbar Fabric-3 Switching Modules with Crossbar Fabric-1 Switching Modules, and then power up the switch.

## Troubleshooting

If the migration procedure fails, downgrade the Crossbar Fabric-3 Switching Modules to Crossbar Fabric-1 Switching Modules.

## Power Supply in a Switch Chassis

You can follow the same steps to install AC and DC power supplies into the switch, but you ground them differently. For an AC power supply, you automatically ground it when you connect its power cable to the power supply and the power source. For a 3-kW DC power supply, you do not directly connect the power supply to the earth ground.

For more information on the supported power modes, power slots and power redundancy for Cisco MDS 9700 Series Switches, see [Power Supplies](#).

### Before you begin

- The switch chassis must be installed in a cabinet or rack that is secured to the data center.
- You need the following tools and equipment:
  - Nut driver attachment for Number 1 Phillips-head screwdriver or ratchet wrench with torque capability (used only for DC power supplies)
  - Crimping tool

- For 3-kW DC power supplies, you need four power cables sized to reach the DC power source or power interface unit (PIU)
- Grounding wire—Size this wire to meet local and national installation requirements. For U.S. installations, you must use a 6 AWG copper conductor. For installations outside the U.S., consult your local and national electrical codes. The length of the grounding wire depends on the proximity of the switch to proper grounding facilities.
- A flat-blade or number 2 Phillips-head screwdriver is required to perform these procedures.

**Warning**

Voltage is present on the backplane when the system is operating. To reduce risk of an electric shock, keep hands and fingers out of the power supply bays and backplane areas. Statement 166

**Warning**

Power supply captive installation screws must be tight to ensure protective grounding continuity. Statement 289

This section provides the following information:

## Installing an AC Power Supply

**Caution**

Use both hands to install and remove power supplies. Each AC power supply weighs up to 6 lb (2.7 kg).

To install an AC power supply in the Cisco MDS 9700 Series switch, follow these steps:

### Procedure

- Step 1** Ensure that the system (earth) ground connection has been made. See the [“Proper Grounding Practices” section](#).
- Step 2** If a filler panel is installed, remove the filler panel from the power supply bay by loosening the captive screw.
- Step 3** Ensure that the power switch is in the off (0) position on the power supply you are installing.
- Step 4** Grasp the power supply handle with one hand, place your other hand underneath the power supply, and slide the power supply into the power supply bay. Ensure that the power supply is fully seated in the bay.
- Step 5** Plug the power cable into the power supply, and place the cable retention device to ensure that the cable cannot be pulled out.

## Connecting an AC Power Supply to an AC Power Source

To connect a 3-kW AC power supply directly to an AC power source, follow these steps:

**Before you begin**

Use one power cord to connect a 3-kW power supply to an AC power source and to ground the power supply. Depending on the software power mode configured on the switch, either connect all of the power supplies to one AC power source (grid) or half of the power supplies to the first independent AC power source (Grid A) and the other half to a second independent AC power source (Grid B). A summary of the grid requirements of each software power mode is shown in the [https://www.cisco.com/c/en/us/td/docs/switches/datacenter/mds9000/hw/9700/mds\\_9700\\_hig/replace.html#59591](https://www.cisco.com/c/en/us/td/docs/switches/datacenter/mds9000/hw/9700/mds_9700_hig/replace.html#59591).

**Table 20: Software Power Mode Grids Required**

Combined	Power Supply Redundancy	Input Source Redundancy	Full Redundancy
1	1	2	2

For information about the software power configuration modes, refer to the “[Supported Transceivers](#)” section.

For information about the location of Grid A and Grid B power supply slots for each type of MDS 9700 Director chassis, refer to the chassis specific information at:

- [Cisco MDS 9718 Chassis Front View](#)
- [Cisco MDS 9710 Chassis Front View](#)
- [Cisco MDS 9706 Chassis Front View](#)

Before you connect a chassis power supply to an AC power source, ensure all of the following:

- There is a vacant receptacle on the AC power source within reach of the chassis power supply cable.
- The power supply is already installed in the chassis.
- The chassis is connected to an earth ground.



**Note** In a single phase AC power supply unit, connection of multiple phases from the same three-phase source is supported and direct connection of three-phase is not supported.

**Procedure**

**Step 1** Ensure that the power supply switch located on the front of the power supply is set at standby (labeled as 0).

**Step 2** Plug one AC power cable into the power supply, and pull down the retention clip over the plug on the power cable.

**Step 3** Plug the other end of the power cable into a AC power source supplied by the data center.

**Warning** To reduce risk of electric shock and fire, take care when connecting units to the supply circuit so that wiring is not overloaded. Statement 1018.

**Warning** This product relies on the building’s installation for short-circuit (over current) protection. To reduce risk of electric shock or fire, ensure that the protective device is rated not greater than: 250V, 20 A. Statement 1005.

**Step 4** Turn the power supply switch from standby to on (from 0 to 1 as labeled on the power switch).

**Step 5** Verify that the power supply is receiving AC power and outputting DC power by making sure that the INPUT and OUTPUT power supply LEDs are lit and the FAULT LED is not lit or flashing. For an explanation of all the power supply LEDs and the conditions that they indicate, see [Table 1-15](#).

**Note** When you first activate the power supply, you can verify the functionality of the LEDs by checking that each LED turns on for a couple of seconds.

If the Fault LED is flashing red, turn the power switch to standby (labeled as 0), check the AC power connections on the power supply and the AC power source, and then turn the power switch back on (labeled as 1). The Input and Output LEDs for the connected power supplies should be green and the Fault LED should be off.

---

## Removing an AC Power Supply



**Warning** Voltage is present on the backplane when the system is operating. To reduce risk of an electric shock, keep hands and fingers out of the power supply bays and backplane areas. Statement 166

To remove an AC power supply from the Cisco MDS 9700 Series switch, follow these steps:

### Procedure

---

**Step 1** Turn the power switch on the power supply to the off (0) position.

**Step 2** Disconnect the power cable from the power source.

**Step 3** Press the release lever latch on the power module.

**Step 4** Release the power cable spring latch retainer.

**Step 5** Grasp the power supply handle with one hand, and slide the power supply partially out of the chassis. Place your other hand underneath the power supply, and slide the power supply completely out of the chassis.

**Note** Each AC power supply weighs between 6 lb (2.7 kg).

**Step 6** If the power supply bay is to remain empty, install a power supply filler panel over the opening, and tighten the captive screw to 8 in-lb.

---

## Installing a DC Power Supply

To install a DC power supply in the Cisco MDS 9700 Series switch, follow these steps:

### Before you begin

The DC power supply for the Cisco MDS 9700 Series switch is 3000KW. This power supply has two operational modes as a function of number of inputs receiving power. The unit will deliver 1551KW when only 1 input is active and 3051KW when 2 inputs are active.

Nominal input voltage range	-48 VDC or -60v VDC (tolerance range: -40 to -75 VDC)
Input current	45A maximum at -40VDC per module



**Warning** Hazardous voltage or energy is present on the backplane when the system is operating. Use caution when servicing. Statement 1034

## Procedure

**Step 1** Ensure that all power is off by locating the circuit breaker on the panel board that services the DC circuit. Switch the circuit breaker to the off position, and tape the switch handle of the circuit breaker in the off position.

Ensure that the power switch is in the off (0) position on the power supply you are installing.

**Warning** Before performing any of the following procedures, ensure that power is removed from the DC circuit. Statement 1003

**Step 2** Grasp the power supply unit handle with one hand, and place your other hand underneath the power supply unit to support its weight. Align the back of the power supply unit with the power supply bay and slide the power supply all the way into the power supply bay until the release lever clicks. Make sure that the power supply unit does not pull out of the power supply bay without pressing the release lever.

## Connecting a DC Power Supply Directly to DC Power Sources

To connect a 3-kW DC power supply to a DC power source, follow these steps:

### Before you begin

Use customer supplied wire to connect a 3 KW power supply to a DC power source. Depending on the software power mode configured on the switch, either connect all of the power supplies to one DC power source (grid) or half of the power supplies to the first independent DC power source (Grid A) and the other half to a second independent DC power source (Grid B). A summary of the grid requirements of each software power mode is shown in the following table.

**Table 21: Software Power Mode Grids Required**

Combined	Power Supply Redundancy	Input Source Redundancy	Full Redundancy
1	1	2	2

For information about the software power configuration modes, see [Supported Transceivers, on page 59](#).

For information about the location of Grid A and Grid B power supply slots for each type of MDS 9700 Director chassis, refer to the chassis specific information at:

- [Cisco MDS 9718 Chassis Front View](#)

- [Cisco MDS 9710 Chassis Front View](#)
- [Cisco MDS 9706 Chassis Front View](#)

## Procedure

---

- Step 1** Turn the power switch to standby (labeled 0 on the power switch).
- Step 2** Turn off the power at the circuit breakers for the portions of the DC grid power that you are connecting to and verify that all the LEDs on the power supplies are off.
- Warning** Before performing any of the following procedures, ensure that power is removed from the DC circuit. Statement 1003
- Warning** Comply with Local and National Electrical Codes: “To reduce risk of electric shock or fire, installation of the equipment must comply with local and national electrical codes.”Statement 1074
- Step 3** Prepare enough length power cable, the wire range 6AWG~8AWG. Size the power cables to the distance between the power supply and the DC power grid. If you need to cut the cable, cut it at the end that connects to the DC power grid, remove 0.75 inch (19 mm) of insulation from the cut ends, and attach them to the DC power system. Be sure to connect the negative cables to negative lines and positive cables to positive lines.
- Note** For all your power connections, if you are using cables with two different colors, use one color cable for all positive circuits and the other color for all negative circuits.
- Warning** Hazardous voltage or energy may be present on DC power terminals. Always replace cover when terminals are not in service. Be sure uninsulated conductors are not accessible when cover is in place. Statement 1075
- Step 4** Remove the three screws that hold down the safety cover for the terminal box on the front of the DC power supply and remove the cover (see the following figure)
- Note** The terminal box has four slots for four power terminals (ordered as negative [-], positive [+], positive [+], and negative [-]). Each terminal has two nuts that you use to fasten a power cable to the terminal.

Figure 52: Removing the Safety Cover for the Terminal Box on the 3-kW DC Power Supply

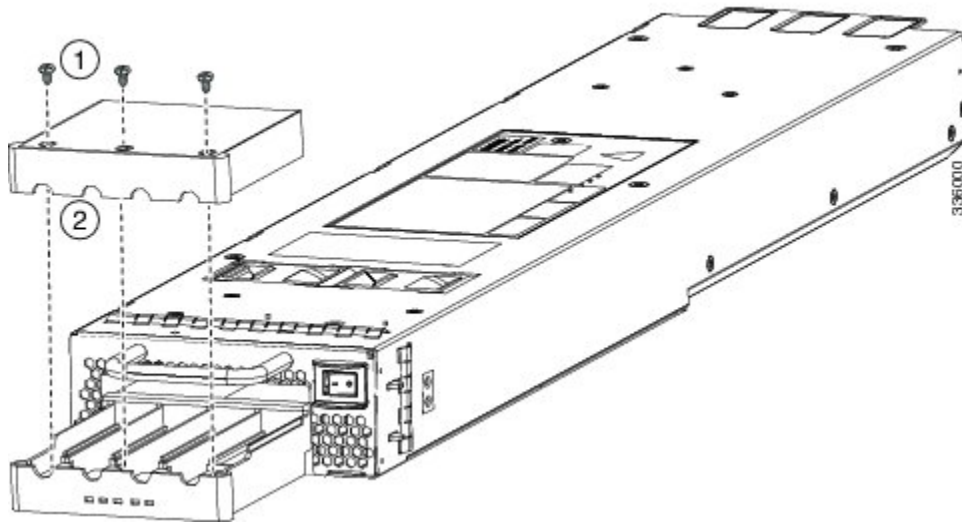

1	Remove screws from cover.
2	Remove the safety cover.

**Step 5** Install four cables (two positive and two negative cables) in the four terminal slots as follows:

- a. Remove 16mm insulation of the other end of the cables.
- b. Unscrew the two nuts in each of the four terminal slots, take out the lug.
- c. Attach and crimp each lug to the end of each power cable
- d. Attach each cable lug to the two terminal posts in each slot, fasten with two nuts, and tighten to 40 in-lb (4.5 N·m).

**Note** For all your power connections, if you are using cables with two different colors, use one color cable for all positive circuits and the other color for all negative circuits.

- e. Replace the safety cover on the terminal box and fasten with three screws.

**Step 6** Install the four cables from the DC power supply to a DC power source as follows:

- a. If the unconnected end of each power cable is not stripped of its insulation for the last 0.75 inches (19 mm), use wire strippers to remove that amount of insulation.
- b. Attach the negative cables to the negative terminals of a DC power source, and attach the positive cables to the positive terminals of the same power source.

**Step 7** For the powered down circuits connected to the power supplies, turn on the power at the circuit breaker. The Input 1 (IN1) and Input 2 (IN2) LEDs turn on each connected power supply.

**Step 8** Turn the power switch on the connected DC power supplies from standby to on (from 0 to 1 as labeled on the power switch for each power supply). The LEDs should flash and then the Output LED should turn on in addition to the Input LEDs.



**Note** If the FAULT LED is lit or flashing, call Cisco TAC for assistance.

---

## Removing a DC Power Supply

The DC power supply for the Cisco MDS 9700 Series switch is 3000 W.

To remove a DC power supply from the Cisco MDS 9700 Series switch, follow these steps:

### Procedure

---

**Step 1** Turn the power switch on the power supply to the off (0) position.

**Step 2** Turn off the DC input power by manually turning off the input circuit at the circuit breaker for this power supply.

**Step 3** Verify that the input power is completely off by making sure that all the LEDs on the DC power supply unit are off.

**Warning** Before performing any of the following procedures, ensure that power is removed from the DC circuit. Statement 1003

**Step 4** Disconnect the DC cables from the terminal block in the following order:

- a. Positive (+)
- b. Negative (-)
- c. Ground

**Caution** In general, the positive (+) terminal is grounded at the battery and is the low end and that should be isolated from ground to prevent a ground loop. Both terminals should be isolated from ground and the negative terminal to ground should be a short and blow the breaker.

**Warning** When installing or replacing the unit, the ground connection must always be made first and disconnected last. Statement 1046

**Warning** Hazardous voltage or energy may be present on DC power terminals. Always replace cover when terminals are not in service. Be sure uninsulated conductors are not accessible when cover is in place. Statement 1075

**Step 5** Press and hold the release latch on the front of the power supply and then pull the power supply part way-out of the chassis by its handle.

**Note** Each DC power supply weighs 11 lb (5 kg).

**Step 6** If the power supply bay is to remain empty, install a power supply filler panel over the opening, and tighten the captive screw to 8 in-lb.

---

# Installing and Removing Fan Modules or Trays

The fan module or tray is designed to be removed and replaced while the system is operating without presenting an electrical hazard or damage to the system, provided the replacement is performed promptly.

The Cisco MDS 9700 Series switches have three fan modules or trays. Each fan module for the Cisco MDS 9710 Director has four individual fans and each fan module or tray for the Cisco MDS 9706 Director has two individual fans with an abrupt stop-to-fan rotation safety feature after power is disconnected or the fan module or tray is removed from the mid-plane.

The Cisco MDS 9000 Family switches have internal temperature sensors that can shut down the system if the temperature at different points within the chassis exceeds certain safety thresholds. To be effective, the temperature sensors require the presence of airflow; therefore, if a fan module is removed from the chassis, the Cisco MDS 9000 Family switches will be shut down to prevent potentially undetectable overheating. However, the switches will be shut down sooner if the higher-level temperature threshold is exceeded. In normal data center conditions, if one fan module fails or needs to be removed, the other two fan modules can cool the system effectively for up to 72 hours.

This section includes the following topics:

## Installing a Fan Module or tray

To install a fan module or tray on the Cisco MDS 9700 Series switch, follow these steps:

### Before you begin

If you need to remove the fan module or tray to replace a fabric module, see the [Removing a Crossbar Fabric Switching Module, on page 165](#).

The fan module or tray displays the fabric module LEDs so that you can see the status of the two fabric modules installed behind that fan module or tray.

### Procedure

---

- Step 1** Hold the fan module or tray so that the Fan Status LED is at the bottom.
- Step 2** Carefully press the whole fan module or tray into the slot so that the four alignment pins go into their holes in the chassis and the electrical connectors at the bottom of the chassis are inserted into the chassis connectors inside the slot. Make sure that the front of the fan module or tray is touching the outer surface of the chassis and that the four captive screws on the fan module or tray are aligned to four screw holes in the chassis.

Figure 53: Installing a Fan Module or tray

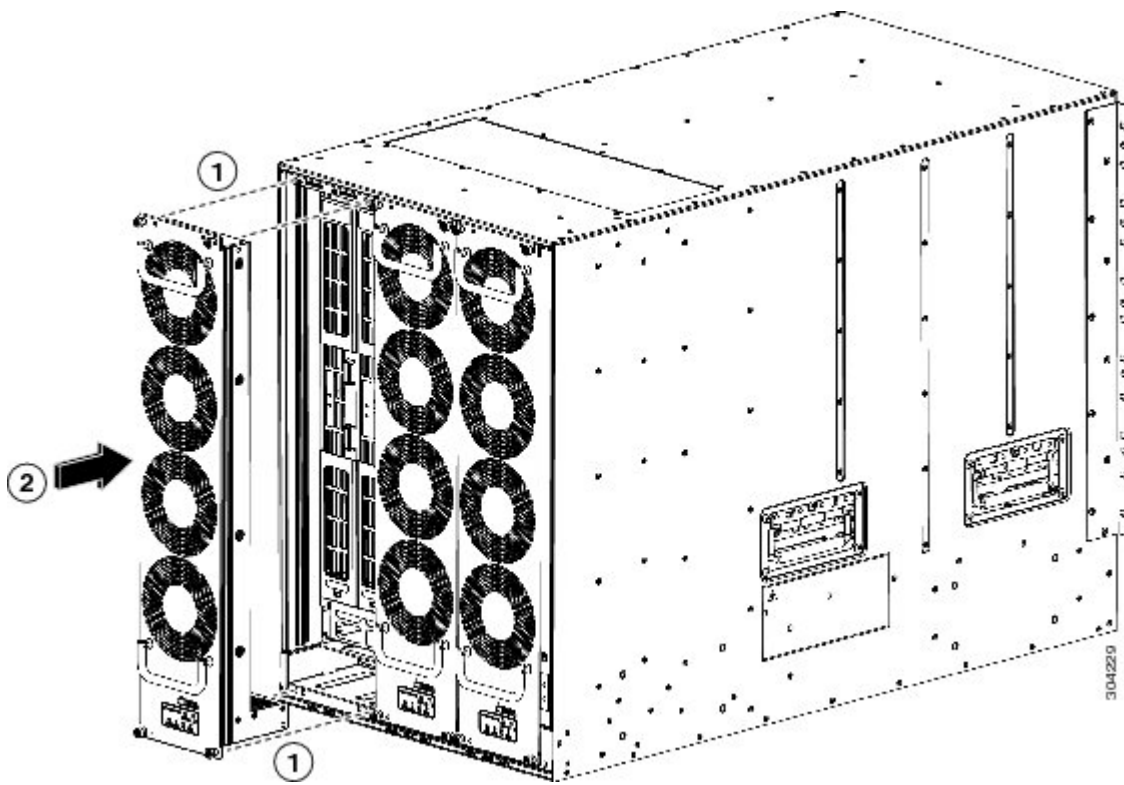

1	Align the four pins in the fan module or tray with four holes in the chassis.	2	Press the whole fan module or tray into the chassis slot.
---	---	---	---

- Step 3** With the electrical contacts on the fan module aligned to contacts on the backplane, press the fan module fully into the slot.
- Step 4** Screw in each of the four captive screws on the front of the fan module or tray to secure the fan module to the chassis. After fully engaged, tighten each screw to 8 in-lb (0.9 N·m) of torque.
- Step 5** Listen for the fans; you should immediately hear them operating. If you do not hear them, ensure that the fan module or tray is inserted completely in the chassis and the outside surface of the fan module or tray is flush with the outside surface of the chassis.
- Step 6** Verify that the Fan Status LED is green. If the LED is not green, one or more fans are faulty. If this occurs, contact your customer service representative for a replacement part.
- Step 7** If the switch is powered on, listen for the fans; you should immediately hear them operating. If you do not hear them, ensure that the fan module or tray is inserted completely in the chassis and the outside surface of the fan module or tray is flush with the outside surface of the chassis.
- Step 8** Verify that the Fan Status LED is green. If the LED is not green, one or more fans are faulty. If this occurs, contact your customer service representative for a replacement part. For more information about the LED states, see the [System LEDs](#), on page 21.

**Note** If you purchased this product through a Cisco reseller, contact the reseller directly for technical support. If you purchased this product directly from Cisco Systems, contact Cisco Technical Support at this URL: [http://www.cisco.com/en/US/support/tsd\\_cisco\\_worldwide\\_contacts.html](http://www.cisco.com/en/US/support/tsd_cisco_worldwide_contacts.html).

---

## Removing a Fan Module or Tray



**Warning** When removing the fan module or tray, keep your hands and fingers away from the spinning fan blades. Let the fan blades completely stop before you remove the fan module. Statement 258

---

From Cisco MDS NX-OS Release 9.4(1), in all Cisco MDS 9700 Series director switches, you can shut down unneeded PSUs. This can be used when there are PSUs in the chassis that are not used based on the power requirements of the switch. It prevents unnecessary alarms in system management software, such as NDFC. For more information, see the [Cisco MDS 9000 Series Fundamentals Configuration Guide](#).

To remove the fan module from a Cisco MDS 9700 Series switch, follow these steps:

### Procedure

---

- Step 1** Use a Phillips torque screwdriver to loosen the four captive screws on the fan module or tray until they are no longer connected to the chassis.
- Step 2** Grasp the handles of the fan module or tray with both hands and pull it outward to unseat the power connector from the backplane.
- Step 3** Pull the fan module or tray fully out of the chassis.

Figure 54: Removing a Fan Module or tray

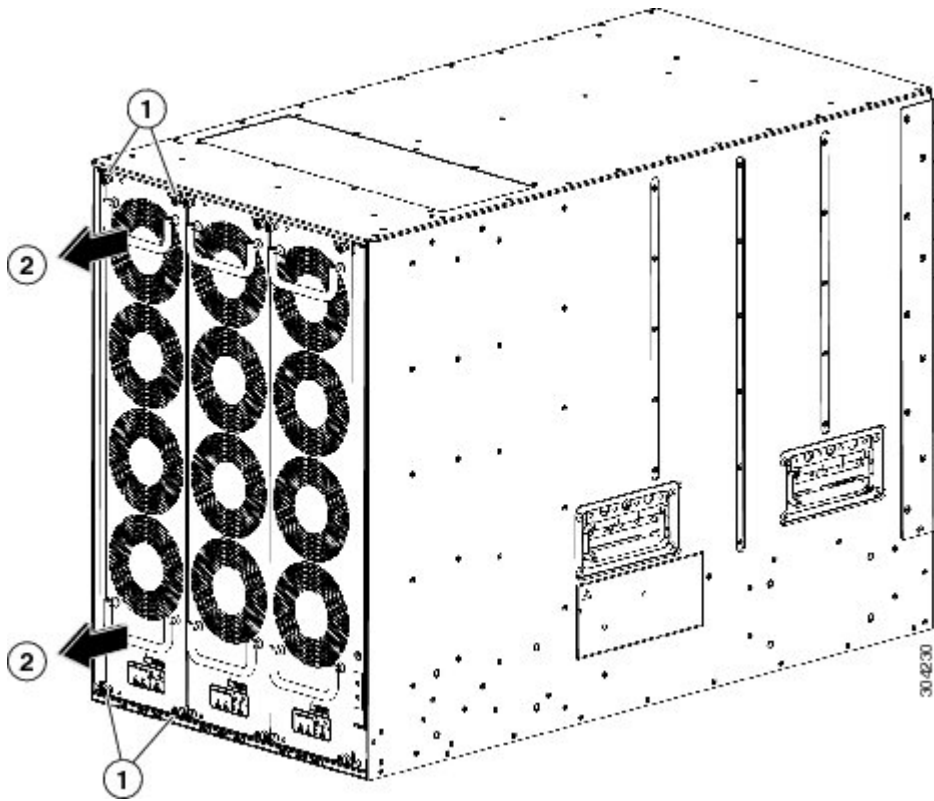

1	Unscrew four captive screws until they are no longer attached to the chassis.
2	Pull both handles to remove the module or tray from the chassis.

**Step 4** Set the fan module or tray down on one of its covered sides only on an antistatic pad or inside an antistatic bag.

**Caution** Keep your face away from the front of the fabric module so that the levers do not hit your face when they spring out from the front of the module.

**Note** It is normal for the fan speeds of the remaining fan modules or trays to increase when one fan module is removed. The fan speeds will return to normal once the fan module is reinstalled.

## Powering up the Switch and Verifying the Component Installation

To power up the switch and verify hardware operation, follow these steps:

**Before you begin**

**Warning** Hazardous voltage or energy is present on the backplane when the system is operating. Use caution when servicing. Statement 1034



**Caution** During this procedure, wear grounding wrist straps to avoid ESD damage to the switch.



**Note** The 3000-W (DS-CAC-3000W) power supplies provide power according to the input voltage. If they are in redundant rather than combined mode at 110 VAC, they may be unable to provide adequate power to all modules present in the system. See [Appendix 6, “Technical Specifications.”](#)



**Warning** Blank faceplates and cover panels serve three important functions: they prevent exposure to hazardous voltages and currents inside the chassis; they contain electromagnetic interference (EMI) that might disrupt other equipment; and they direct the flow of cooling air through the chassis. Do not operate the system unless all cards, faceplates, front covers, and rear covers are in place. Statement 1029



**Note** Do not connect the MGMT 10/100 Ethernet port to the LAN until the initial switch configuration has been performed. For instructions on configuring the switch, see the Cisco MDS 9000 Family NX-OS Fundamentals Configuration Guide.

For instructions on connecting to the console port, see the [“Connecting to the Console Port”](#) section.

**Procedure**

- 
- Step 1** Verify that the faceplates of all modules are flush with the front of the chassis, and the ejector levers are fully closed and approximately parallel to the faceplate of the module.
- Step 2** Verify that any empty module slots have filler panels installed.
- Step 3** Verify that power supplies and the fan module are installed.
- Step 4** Check the power cable retainer of the power supplies, captive screws of fan module, and all supervisor, switching, or services modules, and tighten any retaining screws to specification.
- Step 5** Ensure that the switch is adequately grounded as described in the [“System Grounding”](#) section, and that the power cables are connected to outlets that have the required AC or DC power voltages. See [Appendix 6, “Technical Specifications,”](#) for the required voltages.
- Step 6** Power on the switch by turning the power switches on the power supplies or PEMs to the on (I) position or restoring power to the DC circuit, as required. The switch boots automatically.
- Step 7** Listen for the fans; they should begin operating as soon as the switch is powered on.

**Caution** Do not operate the switch without a functioning fan module except during the brief fan module replacement procedure. The Cisco MDS 9000 Family switches can operate for only a few minutes without a functioning fan module before they begin to overheat.

**Step 8** After the switch has finished booting, verify that the LED operations are as follows:

- Fan module—Status LED is green.
- Power supplies:
  - Input OK LED is IN.
  - Output Fail LED is Fault.
- Supervisor and switching modules:
  - The System LED on the supervisor module is green, indicating that all chassis environmental monitors are reporting that the system is operational. If this LED is orange or red, one or more environmental monitors are reporting a problem.
  - The Status LED on the switching modules flashes orange once, remains orange during diagnostic boot tests, and then turns green when the module is operational (online). If the system software cannot start up, this LED remains orange or turns red.

**Note** The LEDs for the Fibre Channel ports remain orange until the ports are enabled, and the LED for the MGMT 10/100 Ethernet port remains off until the port is connected.

If any LEDs other than the Fibre Channel port LEDs remain orange or red after the initial boot processes are complete, see [Appendix 6, “Technical Specifications.”](#)

**Step 9** If a component is not operating correctly, try removing and reinstalling it. If it still does not operate correctly, contact your customer service representative for a replacement.

**Note** If you purchased this product through a Cisco reseller, contact the reseller directly for technical support. If you purchased this product directly from Cisco Systems, contact Cisco Technical Support at this URL: [http://www.cisco.com/en/US/support/tsd\\_cisco\\_worldwide\\_contacts.html](http://www.cisco.com/en/US/support/tsd_cisco_worldwide_contacts.html).

**Step 10** Verify that the system software has booted and the switch has initialized without error messages. If any problems occur, see the Cisco MDS 9000 Family System Messages Reference. If you cannot resolve an issue, contact your customer service representative.

**Step 11** Complete the worksheets provided in [Appendix 8, “Site Planning and Maintenance Records,”](#) for future reference.

**Note** A setup utility automatically launches the first time you access the switch and guides you through the basic configuration. For instructions about how to configure the switch and check module connectivity, see the Cisco MDS 9000 Family NX-OS Fundamentals Configuration Guide or the Cisco Fundamentals Configuration Guide for DCNM SAN.







## CHAPTER 7

# Technical Specifications

This chapter provides technical specifications and includes the following sections:

- [Switch Specifications, on page 187](#)
- [Module Specifications, on page 189](#)
- [Power Specifications, on page 194](#)
- [Component Power Requirements and Heat Dissipation, on page 196](#)
- [SFP+ Transceiver Specifications, on page 204](#)

## Switch Specifications



**Note** These equipment are designed to boot up in less than 30 minutes, depending on its neighboring devices be fully up and running.

The following table lists the environmental specifications for the Cisco MDS 9700 Series.

**Table 22: Environmental Specifications for the Cisco MDS 9700 Series**

Description	Specification
Temperature, certified for operation	32 to 104°F (0 to 40°C)
Temperature, ambient non operating and storage	–40 to 158°F (–40 to 70°C)
Humidity (RH), ambient (non condensing) operating	10 to 90%
Humidity (RH), ambient (non condensing) non operating and storage	10 to 95%
Altitude, certified for operation	–197 to 6500 ft (–60 to 2000 m)

This section contains the switch specifications for the following models:

## Switch Specifications for Cisco MDS 9706 Director

The following table lists the physical specifications for the Cisco MDS 9706 Director.

**Table 23: Physical Specifications for the Cisco MDS 9706 Director**

Description	Specification
Dimensions (HxWxD)	9 rack units (9 RU) 15.6 x 17.3 x 32.0 in. (39.62 x 43.9 x 81.3 cm)
Weight	Chassis (includes fans): 145 lb (65.8 kg)
Airflow	700 (LFM) average system velocity and between 40 and 160 cubic feet per minute (CFM) total flow through each line-card slot depending on the line-card type and fan-speed setting

## Switch Specifications for Cisco MDS 9710 Director

The following table lists the physical specifications for the Cisco MDS 9710 Director.

**Table 24: Physical Specifications for the Cisco MDS 9710 Director**

Description	Specification
Dimensions (HxWxD)	14 rack units (14 RU) 24.35 x 17.3 x 34.0 in. (61.9 x 43.9 x 86.4 cm)
Weight	Chassis (includes fans): 185.5 lb (84.2 kg)
Airflow	700 (LFM) average system velocity and between 40 and 160 cubic feet per minute (CFM) total flow through each line-card slot depending on the line-card type and fan-speed setting

## Switch Specifications for Cisco MDS 9718 Director

The following table lists the physical specifications for the Cisco MDS 9718 Director.

**Table 25: Physical Specifications for the Cisco MDS 9718 Director**

Description	Specification
Dimensions (HxWxD)	26 rack units (26 RU) 45.25 x 17.3 x 35 in. (114.9 x 43.9 x 88.9 cm)
Weight	Chassis (includes fans): 300 lb (136 kg)
Airflow	700 (LFM) average system velocity and between 40 and 160 cubic feet per minute (CFM) total flow through each line-card slot depending on the line-card type and fan-speed setting

# Module Specifications

This sections contains the following specifications:

## Supervisor-4 Module Specifications

The following table lists the specifications for the Cisco MDS 9700 Supervisor-4 Module (DS-X97-SF4-K9).

**Table 26: Cisco MDS 9700 Supervisor-4 Module Specifications**

Description	Specification
<b>Environmental Requirements</b>	
Temperature, certified for operation (module intake of ambient)	32 to 104°F (0 to 40°C)
Temperature, ambient nonoperating and storage	-40 to 158°F (-40 to 70°C)
Humidity (RH), ambient (noncondensing) operating	10 to 90%
Altitude, designed and tested for operation	-197 to 6500 ft (-60 to 2000 m)
<b>Physical Characteristics</b>	
Dimensions	2.04 x 8.07 x 23.5 in. (5.18 x 20.49 x 59.69 cm)
Weight	7.7 lb (3.5 kg)

## Supervisor-1E Module Specifications

The following table lists the specifications for the Cisco MDS 9700 Supervisor-1E Modules (DS-X97-SF1E-K9).

**Table 27: Cisco MDS 9700 Supervisor-1E Module Specifications**

Description	Specification
<b>Environmental Requirements</b>	
Temperature, certified for operation (module intake of ambient)	32 to 104°F (0 to 40°C)
Temperature, ambient nonoperating and storage	-40 to 158°F (-40 to 70°C)
Humidity (RH), ambient (noncondensing) operating	10 to 90%
Altitude, designed and tested for operation	-197 to 6500 ft (-60 to 2000 m)
<b>Physical Characteristics</b>	

Description	Specification
Dimensions	2.04 x 7.94 x 21.85 in. (5.18 x 20.17 x 55.5 cm)
Weight	8.5 lb (3.86 kg)

## Supervisor-1 Module Specifications

The following table lists the specifications for the Cisco MDS 9700 Supervisor-1 Modules.

*Table 28: Cisco MDS 9700 Supervisor-1 Module Specifications*

Description	Specification
<b>Environmental Requirements</b>	
Temperature, certified for operation (module intake of ambient)	32 to 104°F (0 to 40°C)
Temperature, ambient nonoperating and storage	-40 to 158°F (-40 to 70°C)
Humidity (RH), ambient (noncondensing) operating	8 to 80%
Altitude, certified for operation	0 to 6500 ft (0 to 2000 m)
Altitude, designed and tested for operation	-197 to 6500 ft (-60 to 2000 m)
<b>Physical Characteristics</b>	
Dimensions	2.04 x 7.5 x 21.8 in. (5.18 x 19.05 x 55.37 cm)
Weight	7 lb (3.2 kg)

## Crossbar Fabric Switching Module Specifications

The following table lists the specifications for the Cisco MDS 9700 Series Crossbar Fabric Switching Modules.

*Table 29: Cisco MDS 9700 Series Crossbar Fabric Switching Module Specifications*

Description	Specification
<b>Environmental Requirements</b>	
Temperature, certified for operation (module intake of ambient)	32 to 104°F (0 to 40°C)
Temperature, ambient nonoperating and storage	-40 to 158°F (-40 to 70°C)
Humidity (RH), ambient (noncondensing) operating	10 to 90%
Altitude, certified for operation	0 to 6500 ft (0 to 2000 m)
Altitude, designed and tested for operation	-197 to 6500 ft (-60 to 2000 m)

Description	Specification
<b>Physical Characteristics</b>	
Dimensions	MDS 9718 Crossbar Switching Module <ul style="list-style-type: none"> <li>• Fabric-1: 32.40 x 2.02 x 10.22 in. (82.3 x 5.13 x 25.96 cm)</li> <li>• Fabric-3: 32.40 x 2.02 x 10.22 in. (82.3 x 5.13 x 25.96 cm)</li> </ul>
	MDS 9710 Crossbar Switching Module <ul style="list-style-type: none"> <li>• Fabric-1: 18.09 x 2.02 x 9.22 in. (45.95 x 5.13 x 23.42 cm)</li> <li>• Fabric-3: 18.09 x 2.02 x 9.22 in. (45.95 x 5.13 x 23.42 cm)</li> </ul>
	MDS 9706 Crossbar Switching Module <ul style="list-style-type: none"> <li>• Fabric-1: 11.30 x 2.01 x 7.26 in. (28.02 x 5.11 x 18.44 cm)</li> <li>• Fabric-3: 11.30 x 2.01 x 7.26 in. (28.02 x 5.11 x 18.44 cm)</li> </ul>
Weight	MDS 9718 Crossbar Switching Module <ul style="list-style-type: none"> <li>• Fabric-1: 20 lb (9.07kg)</li> <li>• Fabric-3: 20 lb (9.07 kg)</li> </ul>
	MDS 9710 Crossbar Switching Module <ul style="list-style-type: none"> <li>• Fabric-1: 11 lb (5.0 kg)</li> <li>• Fabric-3: 11 lb (5.0 kg)</li> </ul>
	MDS 9706 Crossbar Switching Module <ul style="list-style-type: none"> <li>• Fabric-1: 5.7 lb (2.6 kg)</li> <li>• Fabric-3: 5.5 lb (2.5 kg)</li> </ul>
	MDS 9706 Crossbar Switching Fabric-1 Module 5.7 lb (2.6 kg)

## 40-Gigabit FCoE Switching Module Specifications

The following table lists the specifications for the Cisco MDS 9700 Series 40-Gigabit FCoE Switching Module.

Table 30: Cisco MDS 9700 Series 40-Gigabit FCoE Switching Module Specifications

Description	Specification
<b>Environmental Requirements</b>	
Temperature, certified for operation (module intake of ambient)	32 to 104°F (0 to 40°C)
Temperature, ambient nonoperating and storage	-40 to 158°F (-40 to 70°C)
Humidity (RH), ambient (noncondensing) operating	5 to 90%
Altitude, certified for operation	0 to 6500 ft (0 to 2000 m)
Altitude, designed and tested for operation	-197 to 6500 ft (-60 to 2000 m)
<b>Physical Characteristics</b>	
Dimensions	1.75 x 15.9 x 21.8 in. (4.4 x 40.39 x 55.37 cm)
Weight	17lb (7.7kg)

## 10-Gigabit FCoE Switching Module Specifications

The following table lists the specifications for the Cisco MDS 9700 Series 10-Gigabit FCoE Switching Module.

Table 31: Cisco MDS 9700 Series 10-Gigabit FCoE Switching Module Specifications

Description	Specification
<b>Environmental Requirements</b>	
Temperature, certified for operation (module intake of ambient)	32 to 104°F (0 to 40°C)
Temperature, ambient nonoperating and storage	-40 to 158°F (-40 to 70°C)
Humidity (RH), ambient (noncondensing) operating	8 to 80%
Altitude, certified for operation	0 to 6500 ft (0 to 2000 m)
Altitude, designed and tested for operation	-197 to 6500 ft (-60 to 2000 m)
<b>Physical Characteristics</b>	
Dimensions	1.75 x 15.9 x 21.8 in. (4.4 x 40.39 x 55.37 cm)
Weight	17lb (7.7kg)

## 10-Gigabit FCoE Switching Module Specifications

The following table lists the specifications for the Cisco MDS 9700 Series 10-Gigabit FCoE Switching Module.

**Table 32: Cisco MDS 9700 Series 10-Gigabit FCoE Switching Module Specifications**

Description	Specification
<b>Environmental Requirements</b>	
Temperature, certified for operation (module intake of ambient)	32 to 104°F (0 to 40°C)
Temperature, ambient nonoperating and storage	-40 to 158°F (-40 to 70°C)
Humidity (RH), ambient (noncondensing) operating	5 to 90%
Altitude, designed and tested for operation	-197 to 6500 ft (-60 to 2000 m)
<b>Physical Characteristics</b>	
Dimensions	1.75 x 15.9 x 21.8 in. (4.4 x 40.39 x 55.37 cm)
Weight	17lb (7.7kg)

## 48-Port 64-Gbps FC Switching Module Specifications

The following table lists the specifications for the Cisco MDS 9700 Series 48-Port 64-Gbps FC Switching Module.

**Table 33: Cisco MDS 9700 Series 48-Port 64-Gbps FC Switching Module Specifications**

Description	Specification
<b>Environmental Requirements</b>	
Temperature, certified for operation (module intake of ambient)	32 to 104°F (0 to 40°C)
Temperature, ambient nonoperating and storage	-40 to 158°F (-40 to 70°C)
Humidity (RH), ambient (noncondensing) operating	10 to 90%
Altitude, designed and tested for operation	-197 to 6500 ft (-60 to 2000 m)
<b>Physical Characteristics</b>	
Dimensions	1.73 x 16.9 x 23.6 in. (4.4 x 43.04 x 59.89 cm)
Weight	17.6 lb (8.0 kg)

## 48-Port 32-Gbps FC Switching Module Specifications

The following table lists the specifications for the Cisco MDS 9700 Series 48-Port 32-Gbps FC Switching Module.

Table 34: Cisco MDS 9700 Series 48-Port 32-Gbps FC Switching Module Specifications

Description	Specification
<b>Environmental Requirements</b>	
Temperature, certified for operation (module intake of ambient)	32 to 104°F (0 to 40°C)
Temperature, ambient nonoperating and storage	-40 to 158°F (-40 to 70°C)
Humidity (RH), ambient (noncondensing) operating	10 to 90%
Altitude, designed and tested for operation	-197 to 6500 ft (-60 to 2000 m)
<b>Physical Characteristics</b>	
Dimensions	1.73 x 15.9 x 21.8 in. (4.4 x 40.39 x 55.37 cm)
Weight	17.5 lb (7.94 kg)

## 48-Port 16-Gbps FC Switching Module Specifications

The following table lists the specifications for the Cisco MDS 9700 Series 48-Port 16-Gbps FC Switching Module.

Table 35: Cisco MDS 9700 Series 48-Port 16-Gbps FC Switching Module Specifications

Description	Specification
<b>Environmental Requirements</b>	
Temperature, certified for operation (module intake of ambient)	32 to 104°F (0 to 40°C)
Temperature, ambient nonoperating and storage	-40 to 158°F (-40 to 70°C)
Humidity (RH), ambient (noncondensing) operating	10 to 90%
Altitude, designed and tested for operation	-197 to 6500 ft (-60 to 2000 m)
<b>Physical Characteristics</b>	
Dimensions	1.75 x 15.9 x 21.8 in. (4.4 x 40.39 x 55.37 cm)
Weight	17 lb (7.71 kg)

## Power Specifications

This section includes the following topics:



## Power Supply Specifications — 3000-W AC Power Supply

The following table lists the specifications for the Cisco MDS 9700 Series power supplies for 3000-W AC Power Supply.

**Table 36: Specifications for Cisco MDS 9700 Series Power Supplies - 3000-W AC Power Supply**

Description	Specification
Type	Autoranging input with power factor corrector.
Voltage	100 to 240 VAC ( $\pm 10\%$ ).
Current rating	16 A maximum at 100 to 120 VAC and 1451-W output. 16 A maximum at 200 to 240 VAC and 3051-W output. For current ratings of plugs, see <a href="#">Supported Plugs for 3000 W AC Power Supplies, on page 208</a>
Frequency	50 to 60 Hz (nominal) ( $\pm 3$ Hz for full range).
Output capacity	1451 W maximum (100 to 120 VAC, 1400W available to chassis) 3051 W maximum (200 to 240 VAC, 3000W available to chassis)
Output voltage at 110/120	3.4V (+/- 4%) at 15A; 50V(+/- 4%) at 28A.
Output voltage at 200/240	3.4V (+/- 4%) at 15A; 50V(+/- 4%) at 28A
Efficiency	>94% at 50% load (80Plus Platinum certified)
ITHD	<5.1% at 50% load

## Power Supply Specifications — 3500-W High Voltage AC/DC Power Supply

The following table lists the specifications for the Cisco MDS 9700 Series power supplies for 3500-W High Voltage AC/DC Power Supply.

**Table 37: Specifications for Cisco MDS 9700 Series Power Supplies - 3500-W High Voltage AC/DC Power Supply**

Description	Specification
Type	Autoranging input with power factor corrector.
Input Voltage Range	120 VAC nominal low-line mode (85 to 132 VAC) 240 VAC nominal high-line mode (170 to 264 VAC) 277 VAC nominal high line mode (188 to 305 VAC) 240 VDC nominal high-line mode (192 to 288 VDC) 380 VDC nominal high-line mode (260 to 400 VDC)
Input Current	20A service, 16A maximum at nominal line voltage (240 or 277 VAC) 20A service, 16A maximum at nominal line voltage (240 or 380 VDC)

Description	Specification
Input Frequency	47 to 63 Hz
Output capacity	1500 W maximum (100 to 120 VAC) 3100 W maximum (200 to 210 VAC) 3500 W maximum (215 to 240 and 277 VAC) 3100 W maximum (200 to 215 VDC) 3500 W maximum (220 to 380 VDC)
Efficiency	>96% at 50% load (80Plus Titanium certified)
ITHD	<6.3% at 50% load

## Power Supply Fuse Information

The following table provides the power supply fuse information for Cisco MDS 9700 Series power supplies.

**Table 38: Power Supply Fuse Information**

Part Number	PID	Type	Fuse Rated AMP	I2T	Fuse Melting Time
341-0579-03	DS-CAC97-3KW	Fast Acting	25 A	2500 5000	100s@32A01s@160A 100s@35A01s@160A
341-0578-01	DS-CDC97-3KW	Fast Acting	60 A	2297	100s@80A01s@380A

## Component Power Requirements and Heat Dissipation

When sizing the air-conditioning requirements for an installation, consider heat dissipation. The power and heat associated with a Cisco MDS 9700 Directors varies based upon the following considerations:

- Power supply type
- Switching module type and number of switching modules installed
- Average switching traffic levels



- Note** Starting from Cisco MDS NX-OS Release 9.4(1),
- The power required by the fan modules is reduced. See the table Power Requirements for the Components of the Cisco MDS 9700 Directors.
  - Power off unused power supplies. See [Removing a Fan Module or Tray, on page 182](#).

The following table lists the power requirements for the components of the Cisco MDS 9700 Directors.

**Table 39: Power Requirements for the Components of the Cisco MDS 9700 Directors**

Module Type/Product Number	Maximum Capacity per Chassis	Power Required (watts)	
		Maximum	Typical
Cisco MDS 9700 48 port 64 Gbps Switching Module (DS-X9748-3072K9)	4 (Cisco MDS 9706)	350	300
Cisco MDS 9700 48 port 32 Gbps Switching Module (DS-X9648-1536K9)	8 (Cisco MDS 9710)	350	260
Cisco MDS 48 port 16 Gbps Switching Module (DS-X9448-768K9)	16 (Cisco MDS 9718)	650	480
Cisco MDS 48 Port 10 Gigabit Fibre Channel over Ethernet Module (DS-X9848-480K9)		500	400
24 Port 40 Gbps Fibre Channel over Ethernet (FCoE) Module (DS-X9824-960K9)		740	550
24/10 port SAN Extension Module (DS-X9334-K9)		480	450
Cisco MDS 9700 Series Supervisor-4 Module (DS-X97-SF4-K9)		2	120
Cisco MDS 9700 Series Supervisor-1E Module (DS-X97-SF1E-K9)	265		160
Cisco MDS 9700 Series Supervisor-1 Module (DS-X97-SF1-K9)	190		110
Cisco MDS 9718 Crossbar Switching Fabric-3 Module (DS-X9718-FAB3)	6	330	285
Cisco MDS 9718 Crossbar Switching Fabric-1 Module (DS-X9718-FAB1)		300	260
Cisco MDS 9710 Crossbar Switching Fabric-3 Module (DS-X9710-FAB3)		150	135
Cisco MDS 9706 Crossbar Switching Fabric-3 Module (DS-X9706-FAB3)		85	64
Cisco MDS 9710 Crossbar Switching Fabric-1 Module (DS-X9710-FAB1)		150	135
Cisco MDS 9706 Crossbar Switching Fabric-1 Module (DS-X9706-FAB1)		85	64

Module Type/Product Number	Maximum Capacity per Chassis	Power Required (watts)	
		Maximum	Typical
Cisco MDS 9718 Fan Module or Tray (DS-C9718-FAN)	3	750 <sup>4</sup>	75
Cisco MDS 9710 Fan Module or Tray (DS-C9710-FAN)		500 <sup>5</sup>	50
Cisco MDS 9706 Fan Module or Tray (DS-C9706-FAN)		250 <sup>6</sup>	40

<sup>4</sup> Starting from Cisco MDS NX-OS Release 9.4(1)  
900 for releases prior to Cisco MDS NX-OS Release 9.4(1)

<sup>5</sup> Starting from Cisco MDS NX-OS Release 9.4(1)  
600 for releases prior to Cisco MDS NX-OS Release 9.4(1)

<sup>6</sup> Starting from Cisco MDS NX-OS Release 9.4(1)  
300 for releases prior to Cisco MDS NX-OS Release 9.4(1)

## Power Requirements and Heat Dissipation for MDS 9710 with 3000 W AC Power Supplies and 64 Gbps Fibre Channel switching modules

The following table lists the requirements and heat dissipation for 3000 W AC power supplies at 64 Gbps speed using Cisco MDS 9700 48 port 64 Gbps Switching Module (DS-X9748-3072K9) and six Fabric Modules for 64 Gbps Speed and three Fabric Modules for 32 Gbps Speed.

**Table 40: 64-Gbps Power Requirements Using 3000 W AC PSUs**

Number of Switching Modules	Number of Ports	Power Required (Watts)				Typical Heat Dissipation (BTU/hr)	
		Typical (32 Gbps)	Typical (64 Gbps)	Worst Case (32 Gbps)	Worst Case (64 Gbps)	Typical (32 Gbps)	Typical (64 Gbps)
1	48	995	1460	2790	3290	3393	4979
2	96	1235	1760	3090	3640	4211	6002
3	144	1475	2060	3390	3990	5030	7025
4	192	1715	2360	3690	4340	5848	8048
5	240	1955	2660	3990	4690	6667	9071
6	288	2195	2960	4290	5040	7485	10094
7	336	2435	3260	4590	5390	8303	11117
8	384	2675	3560	4890	5740	9122	12140

## Power Requirements and Heat Dissipation for MDS 9710 with 3000 W AC Power Supplies and 32 Gbps Fibre Channel switching modules

The following table lists the requirements and heat dissipation for 3000 W AC power supplies at 32 Gbps speed using Cisco MDS 9700 48 port 32 Gbps Switching Module (DS-X9648-1536K9) and six Fabric 1 Modules.

**Table 41: 32-Gbps Power Requirements Using 3000 W AC PSUs**

Number of Switching Modules	Number of Ports	Power Required (Watts)		Typical Heat Dissipation (BTU/hr)
		Typical	Worst Case	
1	48	1440	3340	4910
2	96	1700	3600	5797
3	144	1960	3860	6683
4	192	2220	4120	7570
5	240	2480	4380	8457
6	288	2740	4640	9343
7	336	3000	4900	10230
8	384	3260	5160	11117

The following table lists the requirements and heat dissipation for 3000 W AC power supplies at 32 Gbps speed using Cisco MDS 9700 48 port 32 Gbps Switching Module (DS-X9648-1536K9) and three Fabric 3 Modules.

**Table 42: 32-Gbps Power Requirements Using 3000 W AC PSUs**

Number of Switching Modules	Number of Ports	Power Required (watts)		Typical Heat Dissipation (BTU/hr)
		Typical	Worst Case	
1	48	1015	2750	3461
2	96	1275	3010	4348
3	144	1535	3270	5234
4	192	1795	3530	6121
5	240	2055	3790	7008
6	288	2315	4050	7894
7	336	2575	4310	8781
8	384	2835	4570	9667

## AC Power Consumption for the Cisco MDS 9706 Director

The following table lists the typical AC power consumption for the Cisco MDS 9706 Director.



**Note** The indicated power consumption values refer to when switch ports are fully populated with SFP short wave type.

**Table 43: Typical AC Power Consumption for Cisco MDS 9706 Director**

Speed/Module Type	Number of Fabric Modules	Typical AC Power Consumption (Watts)	
		96 ports	192 ports
64-G operating speed Fibre Channel ports with Cisco MDS 9700 48-port 64-Gbps Switching Module (DS-X9748-3072K9)	6	1304	1904
32-G operating speed Fibre Channel ports with Cisco MDS 9700 48-port 32-Gbps Switching Module (DS-X9648-1536K9)		1244	1764
16-G operating speed Fibre Channel ports with Cisco MDS 9700 48-port 32-Gbps Switching Module (DS-X9648-1536K9)	3	1052	1572
16-G operating speed Fibre Channel ports with Cisco MDS 9700 48-port 16-Gbps Switching Module (DS-X9448-768K9)	3	1492	2452

## AC Power Consumption for the Cisco MDS 9710 Director

The following table lists the typical AC power consumption for the Cisco MDS 9710 Director.



**Note** The indicated power consumption values refer to when switch ports are fully populated with SFP short wave type.

**Table 44: Typical AC Power Consumption for Cisco MDS 9710 Director**

Speed/Module Type	Number of Fabric Modules	Typical AC Power Consumption (Watts)	
		192 ports	384 ports
64-G operating speed Fibre Channel ports with Cisco MDS 9700 48-port 64-Gbps Switching Module (DS-X9748-3072K9)	6	2360	3560
32-G operating speed Fibre Channel ports with Cisco MDS 9700 48-port 32-Gbps Switching Module (DS-X9648-1536K9)		2220	3260

Speed/Module Type	Number of Fabric Modules	Typical AC Power Consumption (Watts)	
		192 ports	384 ports
16-G operating speed Fibre Channel ports with Cisco MDS 9700 48-port 32-Gbps Switching Module (DS-X9648-1536K9)	3	1815	2855
16-G operating speed Fibre Channel ports with Cisco MDS 9700 48-port 16-Gbps Switching Module (DS-X9448-768K9)	3	2695	4615

## AC Power Consumption for the Cisco MDS 9718 Director

The following table lists the typical AC power consumption for the Cisco MDS 9718 Director.



**Note** The indicated power consumption values refer to when switch ports are fully populated with SFP short wave type.

*Table 45: Typical AC Power Consumption for Cisco MDS 9718 Director*

Speed/Module Type	Number of Fabric Modules	Typical AC Power Consumption (Watts)		
		192 ports	384 ports	768 ports
64-G operating speed Fibre Channel ports with Cisco MDS 9700 48-port 64-Gbps Switching Module (DS-X9748-3072K9)	6	3335	4535	6935
32-G/16-G operating speed Fibre Channel ports with Cisco MDS 9700 48-port 32-Gbps Switching Module (DS-X9648-1536K9)		3145	4185	6265
16-G operating speed Fibre Channel ports with Cisco MDS 9700 48-port 16-Gbps Switching Module (DS-X9448-768K9)		4025	5945	9785

## AC Power Supply Requirements for Grid Redundancy of Cisco MDS 9706 Director

The following table lists the AC PSU Requirements for Grid Redundancy of Cisco MDS 9706 Director.

Table 46: MDS 9706 AC PSU Requirements for Grid Redundancy

Configurations	Minimum PSUs Required for Grid Redundancy		
	3000 Watts AC	3000 Watts DC	3500 Watts AC/DC
Up to 3 x Cisco MDS 48 Port 64-Gbps Fibre Channel Switching Modules or Cisco MDS 48-Port 32-Gbps Fibre Channel Switching Modules	2	2	2
Up to 4 x Cisco MDS 48 Port 64-Gbps Fibre Channel Switching Modules or Cisco MDS 48-Port 32-Gbps Fibre Channel Switching Modules	4 <sup>7</sup>	4 <sup>7</sup>	4 <sup>7</sup>
	2 <sup>8</sup>	2 <sup>8</sup>	2 <sup>8</sup>
Any other supported module or a combination of supported modules: <ul style="list-style-type: none"> <li>• 48 Port 64-Gbps Fibre Channel Switching Module</li> <li>• 48-Port 32-Gbps Fibre Channel Switching Module</li> <li>• 24/10 port SAN Extension Module</li> <li>• 24 Port 40-Gbps Fibre Channel over Ethernet Module</li> <li>• 48 Port 16-Gbps Fibre Channel Switching Module</li> <li>• 48 Port 10-Gbps Fibre Channel over Ethernet Module</li> </ul>	4	4	4

<sup>7</sup> Prior to Cisco MDS NX-OS Release 9.4(1)

<sup>8</sup> Starting from Cisco MDS NX-OS Release 9.4(1)

## AC Power Supply Requirements for Grid Redundancy of Cisco MDS 9710 Director

The following table lists the AC PSU Requirements for Grid Redundancy of Cisco MDS 9710 Director.

Table 47: MDS 9710 AC PSU Requirements for Grid Redundancy

Configurations	Minimum PSUs Required for Grid Redundancy		
	3000 Watts AC	3000 Watts DC	3500 Watts AC/DC
Up to 8 x Cisco MDS 48 Port 64-Gbps Fibre Channel Switching Modules	6	6	6



Configurations	Minimum PSUs Required for Grid Redundancy		
	3000 Watts AC	3000 Watts DC	3500 Watts AC/DC
Up to 8 x Cisco MDS 48 Port 32-Gbps Fibre Channel Switching Modules	6 <sup>9</sup>	6 <sup>9</sup>	6 <sup>9</sup>
	4 <sup>10</sup>	4 <sup>10</sup>	4 <sup>10</sup>
Any other supported module or a combination of supported modules: <ul style="list-style-type: none"> <li>• 48 Port 64-Gbps Fibre Channel Switching Module</li> <li>• 48 Port 32-Gbps Fibre Channel Switching Module</li> <li>• 24/10 port SAN Extension Module</li> <li>• 24 Port 40-Gbps Fibre Channel over Ethernet Module</li> <li>• 48 Port 16-Gbps Fibre Channel Switching Module</li> <li>• 48 Port 10-Gbps Fibre Channel over Ethernet Module</li> </ul>	6	6	6

<sup>9</sup> Prior to Cisco MDS NX-OS Release 9.4(1)

<sup>10</sup> Starting from Cisco MDS NX-OS Release 9.4(1)

## AC Power Supply Requirements for Grid Redundancy of Cisco MDS 9718 Director

The following table lists the AC PSU Requirements for Grid Redundancy of Cisco MDS 9718 Director.

**Table 48: MDS 9718 AC PSU Requirements for Grid Redundancy**

Configurations	Minimum PSUs Required for Grid Redundancy		
	3000 Watts AC	3000 Watts DC	3500 Watts AC/DC
Up to 16 x Cisco MDS 48 Port 64-Gbps Fibre Channel Switching Modules	8	8	8
Up to 16 x Cisco MDS 48 Port 32-Gbps Fibre Channel Switching Modules	8	8	8
Up to 12 x Cisco MDS 48 Port 32-Gbps Fibre Channel Switching Modules and up to 4 x 24/10 port SAN Extension Module	8	8	8

Configurations	Minimum PSUs Required for Grid Redundancy		
	3000 Watts AC	3000 Watts DC	3500 Watts AC/DC
Any other supported module or a combination of supported modules: <ul style="list-style-type: none"> <li>• 48 Port 64-Gbps Fibre Channel Switching Module</li> <li>• 48 Port 32-Gbps Fibre Channel Switching Module</li> <li>• 24/10 port SAN Extension Module</li> <li>• 24 Port 40-Gbps Fibre Channel over Ethernet Module</li> <li>• 48 Port 16-Gbps Fibre Channel Switching Module</li> <li>• 48 Port 10-Gbps Fibre Channel over Ethernet Module</li> </ul>	12	12	12

## SFP+ Transceiver Specifications

The Cisco MDS 9700 Series switch is compatible with SFP+ transceivers and cables that have LC connectors. The wavelength of each transceiver must match the transceiver on the other end of the cable, and the cable must not exceed the stipulated cable length for reliable communications.

Cisco SFP+ transceivers provide the uplink interfaces, laser transmit (Tx) and laser receive (Rx), and support 850 to 1610 nm nominal wavelengths, depending upon the transceiver.

Use only genuine Cisco SFP+ transceivers in Cisco MDS 9700 Series switches. Each Cisco SFP+ transceiver is encoded with serial number, vendor name, and other parameters that enable Cisco NX-OS to verify that the transceiver meets the requirements of the switch. If discrepancies are found, the SFP+ will be allowed to function, if possible, but will cause a warning syslog message to be generated. Cisco TAC does not support switch ports populated with non-Cisco SFP+ transceivers.

For more information and detailed specifications, see the [Cisco MDS 9000 Family Pluggable Transceivers Data Sheet](#).



## CHAPTER 8

# Cable and Port Specifications

---

The section provides the cable and port specifications, and includes the following:

- [Cables and Adapters Provided, on page 205](#)
- [Console Port, on page 205](#)
- [Out of Band Management 10/100/1000 Ethernet Port, on page 206](#)
- [Supported Power Cords and Plugs, on page 208](#)

## Cables and Adapters Provided

The Cisco MDS 9700 Series accessory kit includes the following items:

- RJ-45 rollover cable
- RJ-45/DSUB F/F adapter—RJ-45 to DB-25 female DTE adapter (labeled “Terminal”)
- RJ-45/DSUB R/P adapter—RJ-45 to DB-25 male DCE adapter (labeled “Modem”)



---

**Note**

- Additional cables and adapters can be ordered from your customer service representative.
  - If you purchased Cisco support through a Cisco reseller, contact the reseller directly. If you purchased support directly from Cisco Systems, contact Cisco Technical Support at this URL: [http://www.cisco.com/en/US/support/tsd\\_cisco\\_worldwide\\_contacts.html](http://www.cisco.com/en/US/support/tsd_cisco_worldwide_contacts.html)
- 

## Console Port

The console port is an asynchronous RS-232 serial port with an RJ-45 connector. You can use the RJ-45 rollover cable and the RJ-45/DSUB F/F adapter or the RJ-45F PC terminal adapter to connect the console port to a computer running terminal emulation software.

## Console Port Pinouts

The following table lists the pinouts for the console port on the Cisco MDS 9700 Series switch.

Table 49: Console Port Pinouts

Pin	Signal
1 <sup>11</sup>	RTS
2	DTR
3	TxD
4	GND
5	GND
6	RxD
7	DSR
8	CTS

<sup>11</sup> Pin 1 is connected internally to pin 8.

## Connecting the Console Port to a Computer Using the DB-25 Adapter

You can use the RJ-45 rollover cable and RJ-45/DSUB F/F adapter (labeled “Terminal”) to connect the console port to a computer running terminal emulation software. The following table lists the pinouts for the console port, the RJ-45 rollover cable, and the RJ-45/DSUB F/F adapter.

Table 50: Port Mode Signaling and Pinouts with the DB-25 Adapter

Console Port	RJ-45 Rollover Cable		RJ4-5/DSUB F/F Terminal Adapter	Console Device
Signal	RJ-45 Pin	RJ-45 Pin	DB-25 Pin	Signal
RTS	1	8	5	CTS
DTR	2	7	6	DSR
TxD	3	6	3	RxD
GND	4	5	7	GND
GND	5	4	7	GND
RxD	6	3	2	TxD
DSR	7	2	20	DTR
CTS	8	1	4	RTS

## Out of Band Management 10/100/1000 Ethernet Port

The MGMT 10/100/1000 Ethernet port (referred as mgmt0 interface on the switch) is an Ethernet port with an RJ-45 connector. You can use a modular, RJ-45, straight-through UTP cable to connect the management port to an external hub, switch, or router as described in the following figure.

Figure 55: RJ-45 Interface Cable Connector

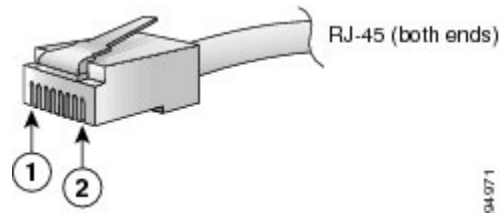

Table 51:

Legend	Description
1	Pin 1
2	Pin 8

The following table lists the connector pinouts and signal names for a 10/100/1000BASE-T management port (MDI) cable.



**Note** The RJ-45 interface only uses pins 1, 2, 3, and 6.

Table 52: 10/100/1000BASE-T Management Port Cable Pinout (MDI)

Pin	Signal
1	TD+
2	TD-
3	RD+
6	RD-
4	Not used
5	Not used
7	Not used
8	Not used

Figure 56: Twisted-Pair 10/100/1000BASE-T Cable Schematic

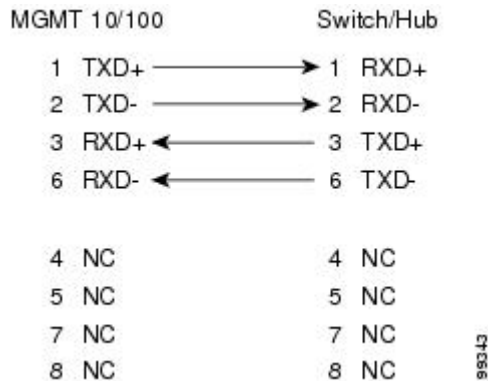

## Supported Power Cords and Plugs

Each power supply has a separate power cord. Standard power cords or jumper power cords are available for connection to a power distribution unit having IEC 60320 C19 outlet receptacles.

### Power Cords

The standard power cords have an IEC C19 connector on the end that plugs into the switch. The optional jumper power cords have an IEC C19 connector on the end that plugs into the switch, and an IEC C20 connector on the end that plugs into an IEC C19 outlet receptacle.



#### Note

- Only the regular power cords or jumper power cords are provided with the switch.
- If you do not order the optional power cord with the system, you are responsible for selecting the appropriate power cord for the product. Using a non-compatible power cord with this product may result in electrical safety hazard. Orders delivered to Argentina, Brazil, and Japan must have the appropriate power cord ordered with the system.

The following table lists the power cords for the Cisco MDS 9700 Series switch and provides their lengths in feet and meters.

### Supported Plugs for 3000 W AC Power Supplies

The following figure shows the supported plugs for the 3000 W AC power supplies.

Figure 57: 3000-W AC Power Supply Plugs

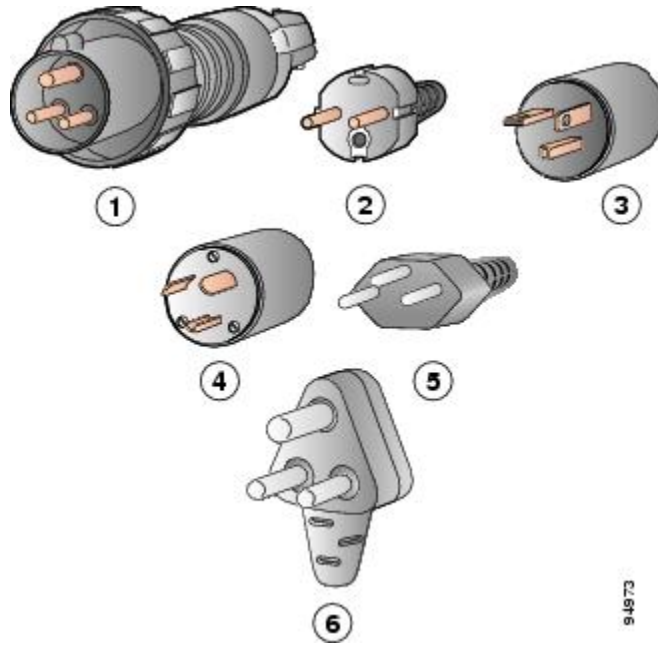

Legend	Description
1	International ( 3000 W) IEC 309 (20 A)
2	Europe (3000 W) CEE 7/7 (16 A)
3	North America (non-locking) -3000W NEMA 6-20 plug (20 A)
4	North America (locking) (3000 W) NEMA L6-20 plug (20 A)
5	Switzerland (3000 W) 23 G SEV 1011 (16 A)
6	South Africa (3000 W) EL 208, SABS 164-1 (16 A)

The following figure shows an additional plug that is supported for the 3000 W power supply using 110 VAC.



**Note** Using the plug displayed in the following figure at 110 VAC results in 1450 W available to the system.

Figure 58: Additional Power Supply Plug Supported for 3000 W 110 VAC Only

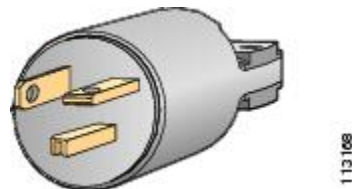

Legend	Description
1	NEMA 5-20P North American power cord product ID: CAB-7513AC 110 VAC (20 A)

## Power Supply AC Power Cords

The following table lists the specifications for the 3000 W AC power cords that are available for the AC-input power supply. Included in the table are references to illustrations of the power cords.

*Table 53: Power Supply AC Power Cords*

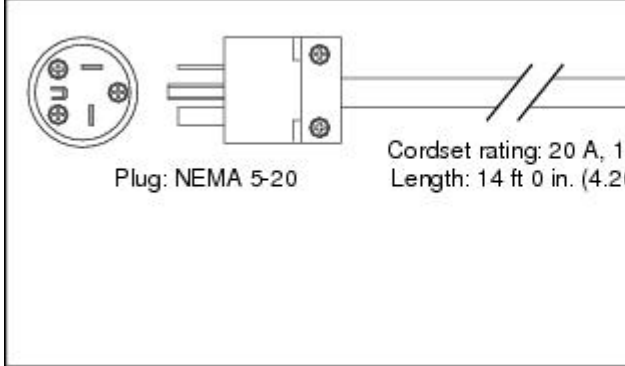
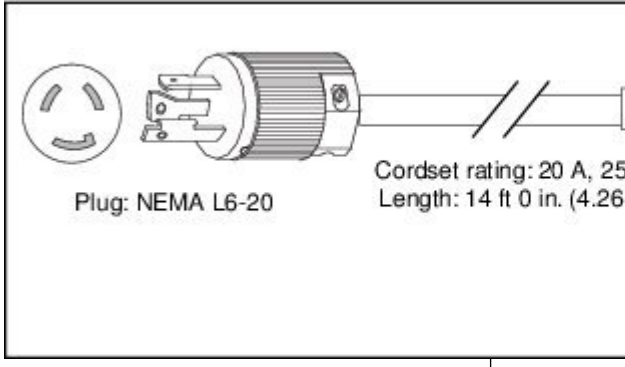
Locale	Power Cord Part Number	Source Plug Type	Cordset Rating	
North America/Japan	CAB-9K2A-NA	NEMA 5-20	20 A, 125 VAC	 <p>Plug: NEMA 5-20 Cordset rating: 20 A, 125 VAC Length: 14 ft 0 in. (4.27 m)</p>
US/Japan	CAB-9K16A-US2	NEMA L6-20	16 A, 250 VAC	 <p>Plug: NEMA L6-20 Cordset rating: 16 A, 250 VAC Length: 14 ft 0 in. (4.27 m)</p>

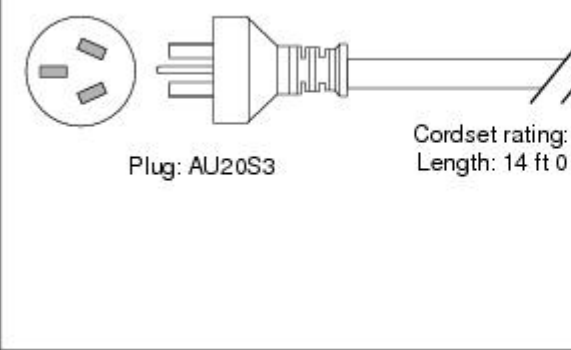
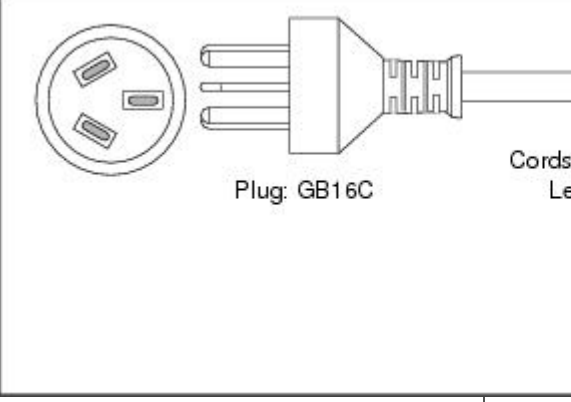
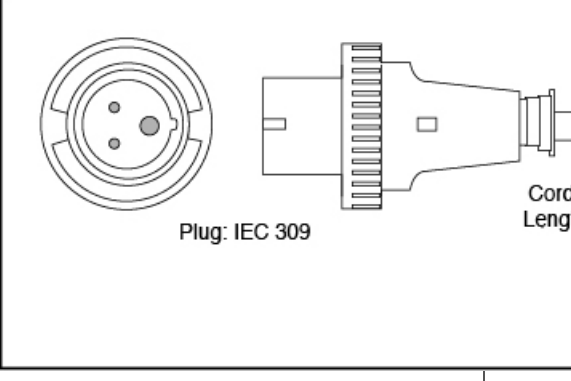

Locale	Power Cord Part Number	Source Plug Type	Cordset Rating	
Australia	CAB9K16A-AUS	AU20S3	16 A, 250 VAC	 <p>Diagram showing the AU20S3 plug and cordset. The plug is a three-pronged Australian standard plug. The cordset is labeled with a rating of 16 A, 250 VAC and a length of 14 ft 0 in.</p> <p>Plug: AU20S3</p> <p>Cordset rating: 16 A, 250 VAC Length: 14 ft 0 in</p>
China	CAB9K16A-CH	GB16C	16 A, 250 VAC	 <p>Diagram showing the GB16C plug and cordset. The plug is a three-pronged Chinese standard plug. The cordset is labeled with a rating of 16 A, 250 VAC and a length of 14 ft 0 in.</p> <p>Plug: GB16C</p> <p>Cordset rating: 16 A, 250 VAC Length: 14 ft 0 in</p>
International	CAB9K16A-INT	IEC 309	16A 250V AC	 <p>Diagram showing the IEC 309 plug and cordset. The plug is a three-pronged international standard plug. The cordset is labeled with a rating of 16A 250V AC and a length of 14 ft 0 in.</p> <p>Plug: IEC 309</p> <p>Cordset rating: 16A 250V AC Length: 14 ft 0 in</p>

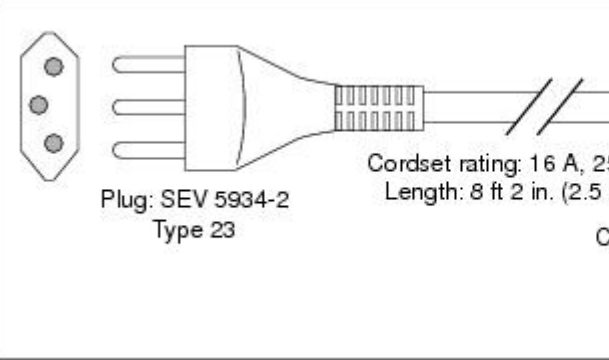
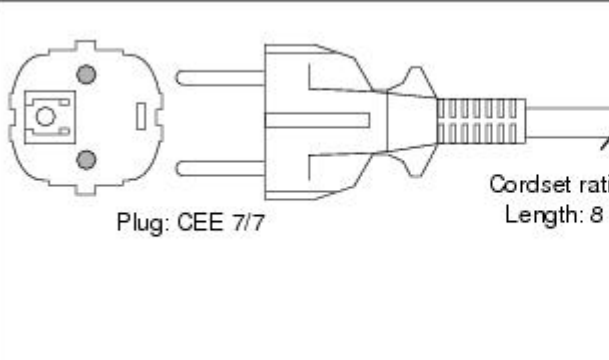
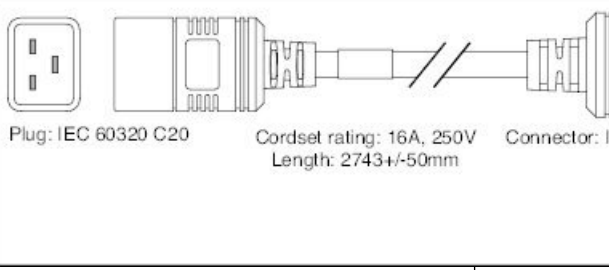
Locale	Power Cord Part Number	Source Plug Type	Cordset Rating	
Switzerland	CAB-9K16A-SW	SEV 5934	16 A 250 VAC	 <p>Plug: SEV 5934-2 Type 23</p> <p>Cordset rating: 16 A, 250 V Length: 8 ft 2 in. (2.5 m)</p>
Continental Europe	CAB-9K16A-EU	CEE7/7	16 A 250 VAC	 <p>Plug: CEE 7/7</p> <p>Cordset rating: 16 A, 250 V Length: 8 ft 2 in. (2.5 m)</p>
Cabinet Jumper Power Cord	CAB-C19-CBN	C 20-C19	16 A 250 VAC	 <p>Plug: IEC 60320 C20</p> <p>Cordset rating: 16A, 250V Length: 2743+/-50mm</p> <p>Connector: C19</p>



## CHAPTER 9

# Site Planning and Maintenance Records

---

- [Contacting Customer Service](#), on page 213
- [Finding the Chassis Serial Number](#), on page 213
- [Site Preparation Checklist](#), on page 214

## Contacting Customer Service

If you are unable to solve a startup problem after using the troubleshooting suggestions in this appendix, contact your customer service representative for assistance and further instructions. Before you call, have the following information ready to help your service provider assist you as quickly as possible:

- Date you received the switch.
- Chassis serial number. See [Finding the Chassis Serial Number](#), on page 213.
- Type of software and release number.
- Maintenance agreement or warranty information.
- Brief description of the problem.
- Brief explanation of the steps you have already taken to isolate and resolve the problem.



---

**Note** If you purchased Cisco support through a Cisco reseller, contact the reseller directly. If you purchased support directly from Cisco, contact Cisco Technical Support at this URL:  
[http://www.cisco.com/en/US/support/tsd\\_cisco\\_worldwide\\_contacts.html](http://www.cisco.com/en/US/support/tsd_cisco_worldwide_contacts.html)

---

## Finding the Chassis Serial Number

You can find the chassis serial number label of the Cisco MDS 9700 Series on the chassis.

If you have CLI access, enter the **show sprom backplane** command to display the backplane contents, including the switch serial number.

# Site Preparation Checklist

Planning the location and layout of your equipment rack or wiring closet is essential for successful switch operation, ventilation, and accessibility.

Consider heat dissipation when sizing the air-conditioning requirements for an installation. See [Table 6-1](#) for the environmental requirements. See the [“Environmental and Power Requirements for Cisco 16-Gbps Fibre Channel SFP+ Transceivers”](#) section, the [“Maximum Environmental and Electrical Ratings for Cisco Fibre Channel SFP+ Transceivers”](#) section for power and heat ratings.



# CHAPTER 10

## Accessory Kit Contents



- [Accessory Kit Contents](#), on page 215

## Accessory Kit Contents

This appendix lists and illustrates the Cisco MDS 9700 Series accessory kit contents (part number 53-4093-XX).

**Table 54: Cisco MDS 9700 Switch Accessory Kit Contents**

Part Number	Illustration	Description
69-2503-XX		Support rack-mount bracket kit (includes the following parts) 12-24 x 3/4-in. Phillips screws M6 x19-mm Phillips screws 10-32 x 3/4-inch screws Support rack-mount bracket
800-05097-XX		<b>Console cable connector kit</b> (includes the following parts) RJ-45 rollover cable DB-9F/RJ-45F PC terminal RJ-45/DSUB F/F adapter R-J45/DSUB R/P adapter DSUB screw lock kit

Part Number	Illustration	Description
69-1815-XX	Ground lug kit 	<b>Ground lug kit</b> (includes the following parts) Two-hole lug M4 x 8-mm Phillips pan-head screws
79-0087-XX	ESD wrist strap 	<b>ESD wrist strap</b>
700-29059-01		<b>SFP Extractor</b>
78-21186-XX	Not applicable	Product Documentation Pointer Card
78-17985-XX	Not applicable	China Management Methods Hazardous Substances Content Table



**Note** If you do not receive any part listed in this document, contact Cisco Technical Support at this URL: <http://www.cisco.com/warp/public/687/Directory/DirTAC.shtml>. If you purchased this product through a Cisco reseller, you may receive additional contents in your kit, such as documentation, hardware, and power cables.

Each new switch ships with country-specific power cords—the shipped cords depend on your specification when placing a Cisco MDS switch order. The available power cords for the Cisco MDS 9710 Director are as follows:

- CAB-9K16A-AUS—power cord, 250-VAC 16-A, Src Plug A, Australia
- CAB-9K16A-CH—power cord 250-VAC 16-A, Src Plug GB16C, China
- CAB-9K16A-EU—power cord 250-VAC 16-A, Src Plug CEE, Europe
- CAB-9K16A-INT—power cord 250-VAC 16-A, Src Pl, International
- CAB-9K16A-ISR—power cord 250-VAC 16-A, Src Plug SI16, Israel
- CAB-9K16A-SA—power cord 250-VAC 16-A, Src Plug EL, South Africa
- CAB-9K16A-SW—power cord 250-VAC 16-A, Src Plug SEV 5, Switzerland
- CAB-9K16A-US1—power cord 250-VAC 16-A, Src Plug NE, US and Japan
- CAB-9K16A-US2—power cord 250-VAC 16-A, Src Plug NE, US and Japan

- CAB-9K16A-KOR—power cord 250-VAC 16-A, Korea, Src Plug
- CAB-9K20A-NA—power cord 125VAC 20A NEMA 5-20 Plug, North America/Japan
- CAB-9K16A-ARG—power cord 250VAC 16A, Argentina, Src Plug IR2073-C19
- CAB-9K16A-BRZ—power cord 250VAC 16A, Brazil, Src Plug EL224-C19
- CAB-C19-CBN—cabinet jumper power cord, 250 VAC 16A, C20-C19 Connector

The available power cords for the Cisco MDS 9718 Director are as listed in the Cisco MDS 9718 Multilayer Director Datasheet.

