

Common Issues With IP Addressing and Static Routes on the 15454

Document ID: 6113

Contents

Introduction

Prerequisites

- Requirements
- Components Used
- Conventions

Background Information

Link Level Connectivity

IP Level Connectivity

- Configure the 15454
- Troubleshoot the 15454
- Understand the 15454 Routing Table
- Troubleshoot the 15454 Routing Table
- Configure the Router
- Troubleshoot the Router
- Troubleshoot the CTC
- Configure the 15454 IP Parameters Through the Front Panel LCD
- Enter the IP Address From the Front Panel LCD

Common IP Addressing Scenarios for the 15454

- IP Scenario 1
- IP Scenario 2
- IP Scenario 3
- IP Scenario 4
- IP Scenario 5
- IP Scenario 6
- IP Scenario 7

IP Scenario Troubleshooting

Related Information

Introduction

You encounter several common issues when you configure IP addresses and static routes you require on a network that runs ONS 15454 optical switches. This document uses a documented lab setup to guide you through a typical network configuration, and explains where these common issues occur.

Prerequisites

Requirements

There are no specific requirements for this document.

Components Used

This document is not restricted to specific software and hardware versions.

The information in this document was created from the devices in a specific lab environment. All of the devices used in this document started with a cleared (default) configuration. If your network is live, make sure that you understand the potential impact of any command.

Conventions

Refer to Cisco Technical Tips Conventions for more information on document conventions.

Background Information

This document begins with how to establish link level connectivity, and moves on to describe how to configure and troubleshoot IP connectivity on the 15454, Cisco routers, and the Cisco Transport Controller (CTC). This document then provides a series of troubleshooting guides for the most common IP scenarios.

Although each IP network is unique, this document uses the network topology in Figure 1 to illustrate the principles that guide you to configure a 15454 IP network. After you read through the configuration steps for the sample network, you can apply them to your specific network.

Typically, you would plug the 15454 and the Personal Computer (PC) into a switch on the edge of each side of the routed network. Then create a routed network connection between the switches. In the topology diagram in Figure 1, Switch-A and Switch-B represent the switches on either side of the network, and Router-C represents the routed network.

Figure 1 Sample Network Topology

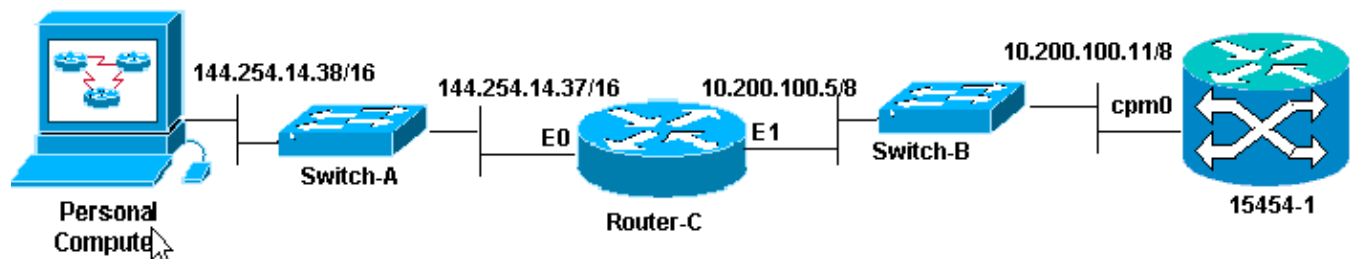

Configure the ONS 15454 to see the IP address on the PC. The personal computer uses the **ping** and **tracert** commands to verify the IP connectivity to the ONS 15454.

Link Level Connectivity

The sample network uses two types of Ethernet cable, namely, straight-through and crossover. This table enables you to verify which type of Ethernet cable to use between the various network connections:

	TCC	Wire wrapped backplane pins
PC or Workstation	Straight through cable	A1 RJ-45 pin 2
		B1 RJ-45 pin 1
		A2 RJ-45 pin 6
Router		B2 RJ-45 pin 3
Hub or Switch	Cross over	A1 RJ-45 pin 6

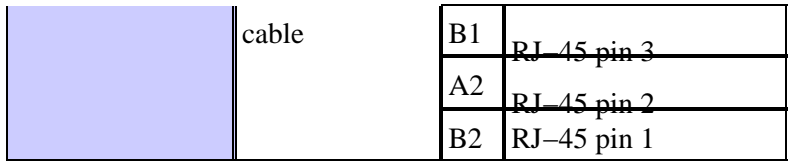

Figure 2 shows an example of a straight-through Ethernet cable.

Note: The snap tab at both ends is to the back of the connector.

Figure 2 Example of a Straight-through Ethernet Cable

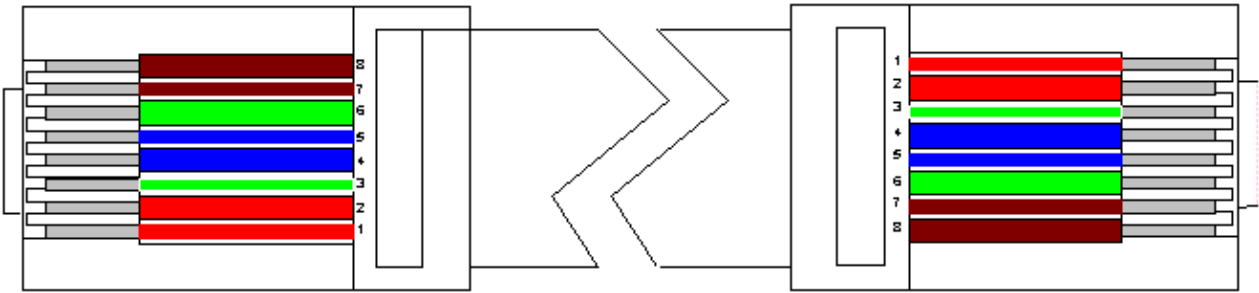
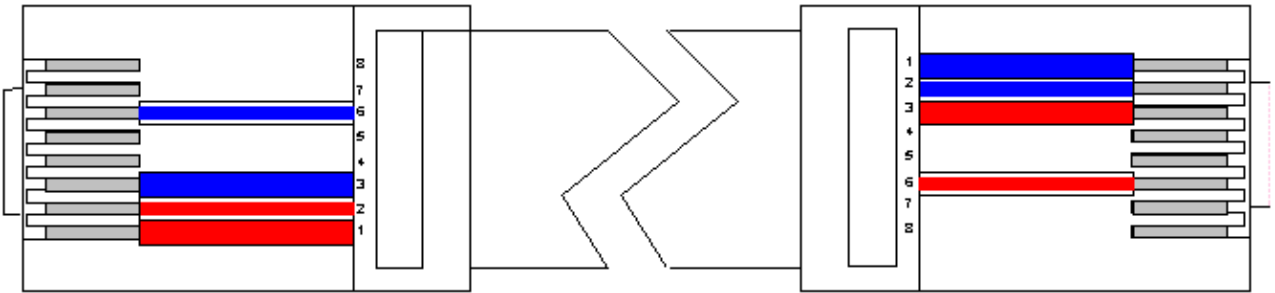

Figure 3 illustrates an example of a crossover Ethernet cable.

Note: The snap tab at both ends is to the back of the connector.

Figure 3 Example of a Crossover Ethernet Cable



The sample network uses the cables as shown in Figure 4.

Figure 4 Cable Usage

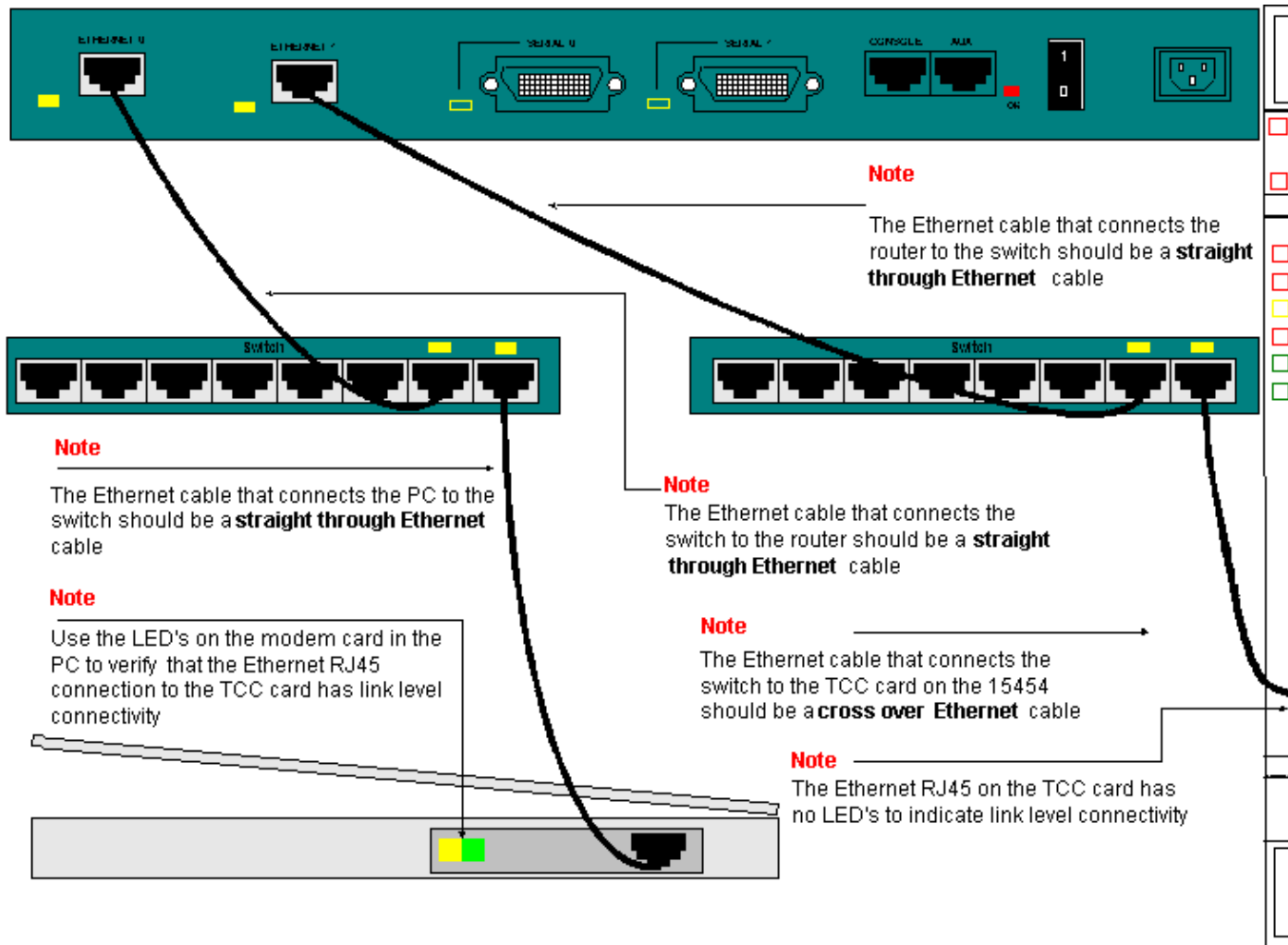

If you need to troubleshoot the link level connectivity, the best place to begin is the LEDs on the RJ-45 ports.

Note: No LED is available on the RJ-45 port on the Timing Communication and Control (TCC) card.

In order to troubleshoot link level connectivity, ensure that you check for these issues:

- Bad cable
- Incorrect cable or pinouts
- Bad port on TCC, PC, hub, or router (try another port or swap the port out)
- Incorrect speed or duplex (the Ethernet port of TCC is 10baseT half duplex)

IP Level Connectivity

You can store upto 16 static routes in the 15454 network element database in order to provide IP connectivity to remote CTC workstations that attach to the 15454 through routers. Provision the static routes on the 15454 network element through the CTC.

Note: The current version of CTC software (v2.2.x) limits the number of concurrent CTC sessions per 15454 node to four. Release 3.x and later can handle up to five concurrent CTC sessions. CTC performance can vary, based upon the volume of activity in each session, network bandwidth, TCCx card load and the size of the DCC connected network.

For example, a Network Operations Center (NOC) can remotely monitor a 15454 through CTC, while at the

same time an on-site employee is logged into a 15454 on the network with a separate CTC session.

In order to provision these static routes, you need to configure changes in the 15454 and CTC workstations. The next section provides an example of how to provision a static route on the 15454 for the router linked CTC workstation in the sample network topology.

For other typical IP address scenarios, see the Common IP Addressing Scenarios section of this document. These scenarios contain additional details on router and CTC workstation setup that support the static route provisioning on the 15454 network element described here.

Configure the 15454

Complete these steps to configure the 15454:

1. Select the **Provisioning > Network** tabs from the Node view of CTC.
2. Select **Create** in the Static Routes panel.

The **Create Static Route** panel appears:

Figure 5 Create Static Routes

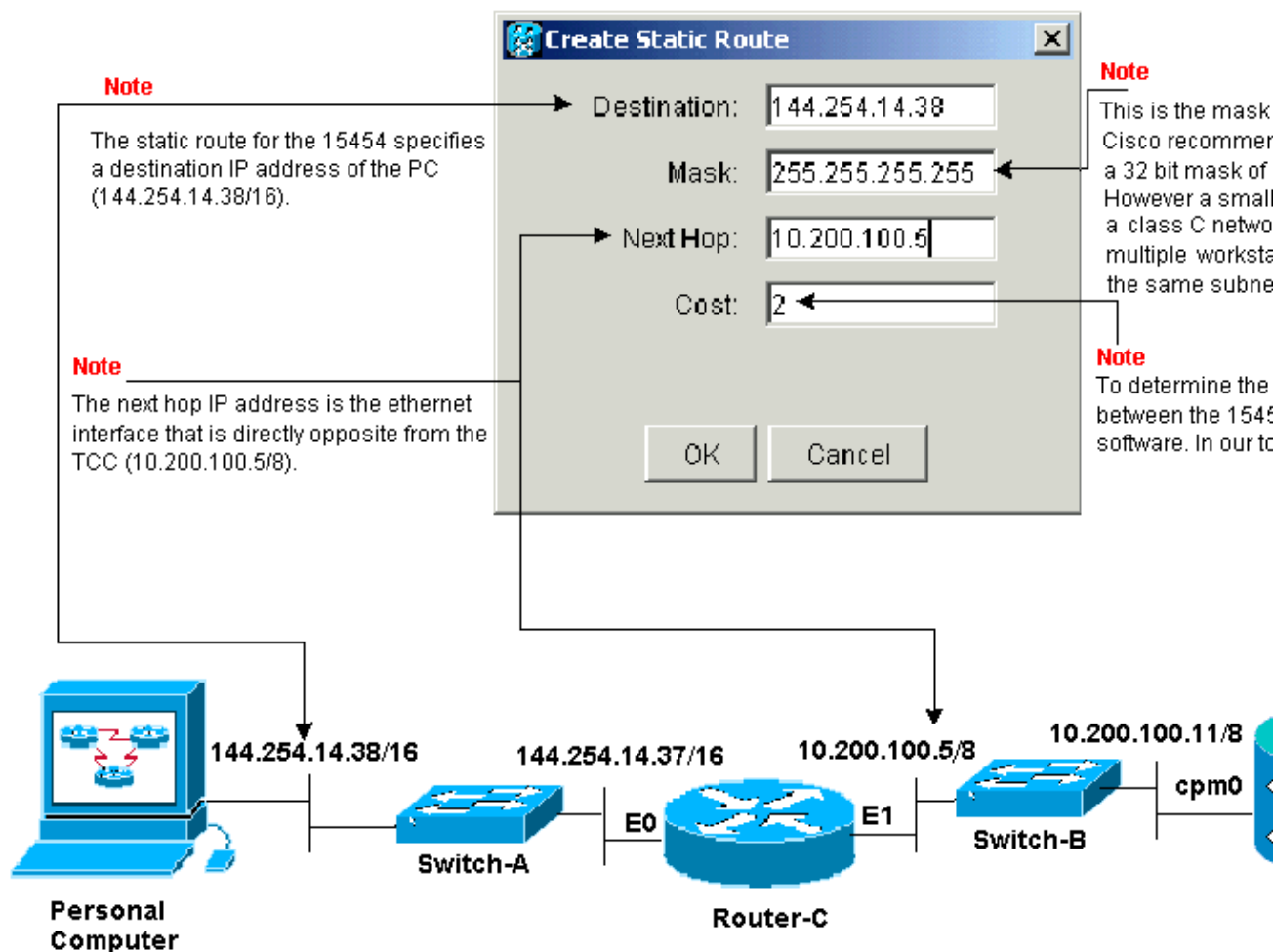

The **Create Static Route** panel provisions a static route to enable the 15454 to establish an IP session through the router to a CTC workstation at the destination IP address that you specify in the static route. In the sample network, the workstation resides in a Class B network with a 16-bit subnet mask. The IP address of the CTC workstation is 144.254.14.38.

The 15454 resides in a Class A network with an eight-bit subnet mask. The IP address of the Ethernet management interface (cpm0) on the TCC card is 10.200.100.11. On Router-C, the IP address of the Ethernet interface (E1) on the same segment as the 15454 is 10.200.100.5.

Figure 6 Static Routes

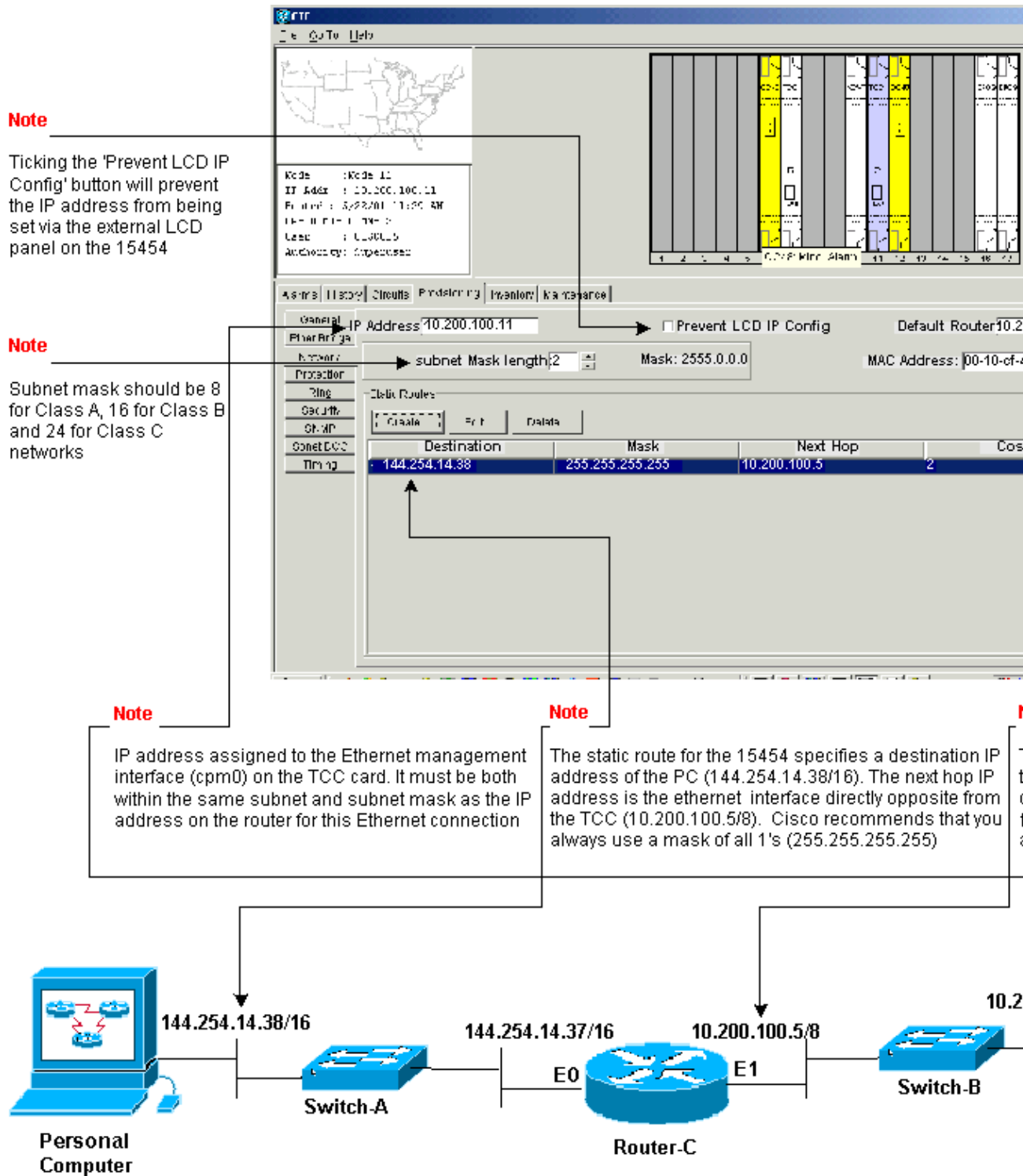

Troubleshoot the 15454

If you experience problems when you try to configure static routes on the 15454, check for these issues:

- Incorrect IP address or subnet mask:

Interfaces on the same network must have IP addresses that are within the same subnet to communicate directly.

- Duplicate IP addresses:

IP addresses must be unique. The network portion can be the same for all addresses, but the host portion must be unique.

- Incorrect or missing default gateway in 15454 gateway node:

Configure default router on gateway 15454 node as the Ethernet IP address of adjacent routers.

- Incorrect or missing static routes in 15454 gateway node:

Configure the destination IP address in the static route to point to the IP address assigned to the CTC workstation. The static route is automatically redistributed to all other 15454 nodes.

Understand the 15454 Routing Table

In order to achieve CTC connectivity to each other, all of the interconnected 15454 network elements in a ring form an Open Shortest Path First (OSPF) area. The nodes use the Synchronous Optical Network (SONET) Data Communication Channel (SDCC) links for communication. The elements advertise the routing table information in the individual nodes to the other 15454s that the DCCs connect.

Assume that the 15454 in the sample network topology was one of four nodes in a Bi-Directional Line Switch Ring (BLSR) ring (see Figure 7).

Figure 7 BLSR

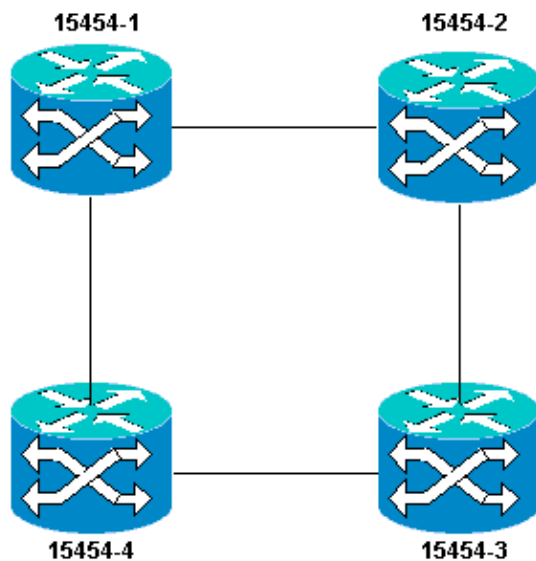

The Node advertises the static route that you configured to the other three nodes in the ring.

Figure 8 indicates that the top left 15454 (10.200.100.11) advertises the static route to the other three nodes in the ring. All the nodes now share the static route in their routing tables.

Figure 8 10.200.100.11 Advertises the Static Route

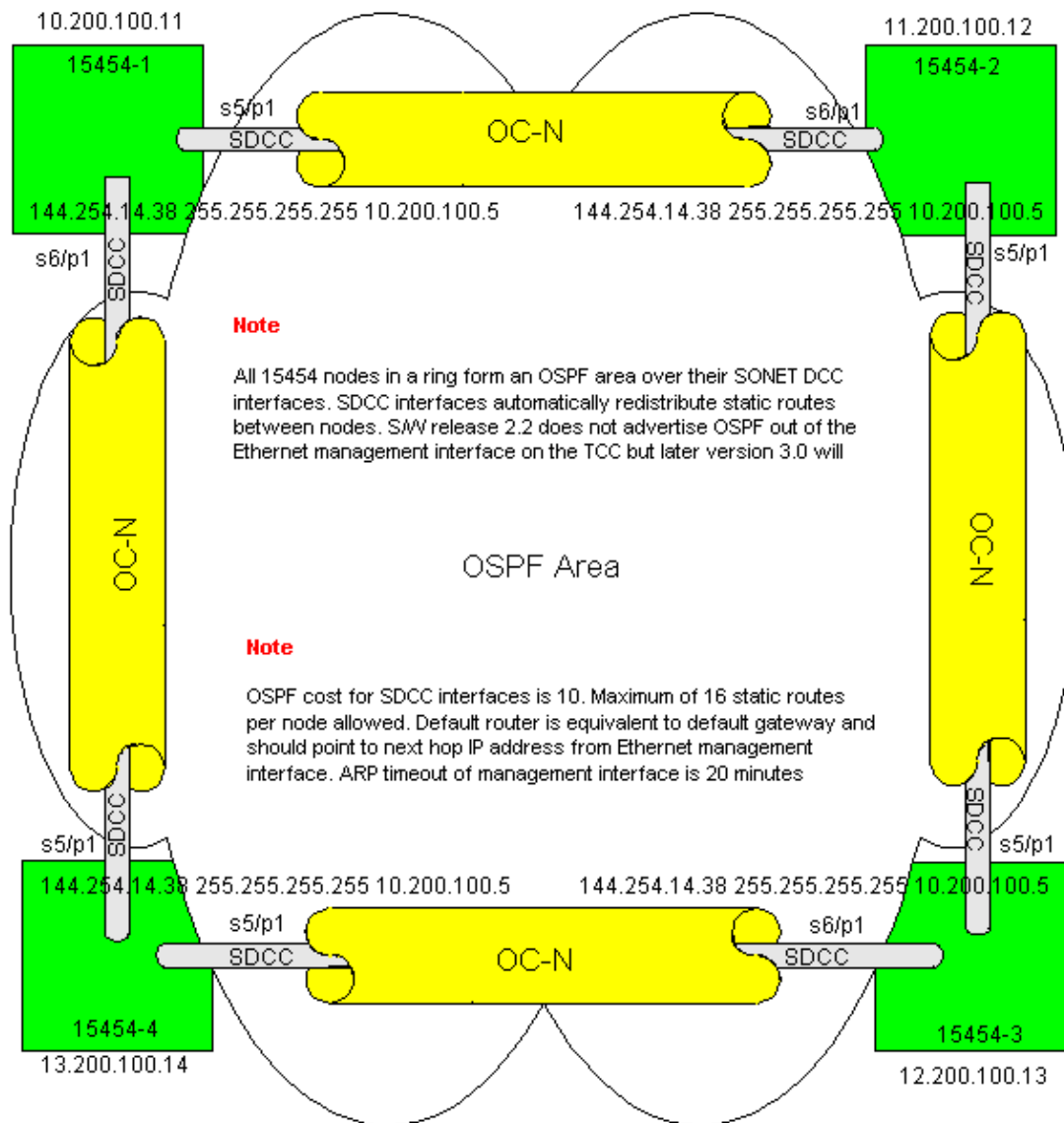

Troubleshoot the 15454 Routing Table

Here are the possible causes of SDCC connectivity problems:

- You have not configured SDCC terminations, or configured the terminations incorrectly. When you configure the SDCC, never change the area ID or Disable OSPF on the SDCC unless you want to divide the network into different OSPF areas for management purposes. You would generally use these parameters when you integrate the ONS network with OSPF on the LAN.
- Fiber path is not established (Loss of Signal (LOS) and Loss of Frame (LOF) alarms and signal degradation).
- Optical Carrier, level N (OC-N) ports are not in service.
- You have not configured SDCC tunnels.

Configure the Router

This section extends the sample network topology to include the four-node BLSR ring (see Figure 9):

Figure 9 Network Topology with the 4-Node BLSR

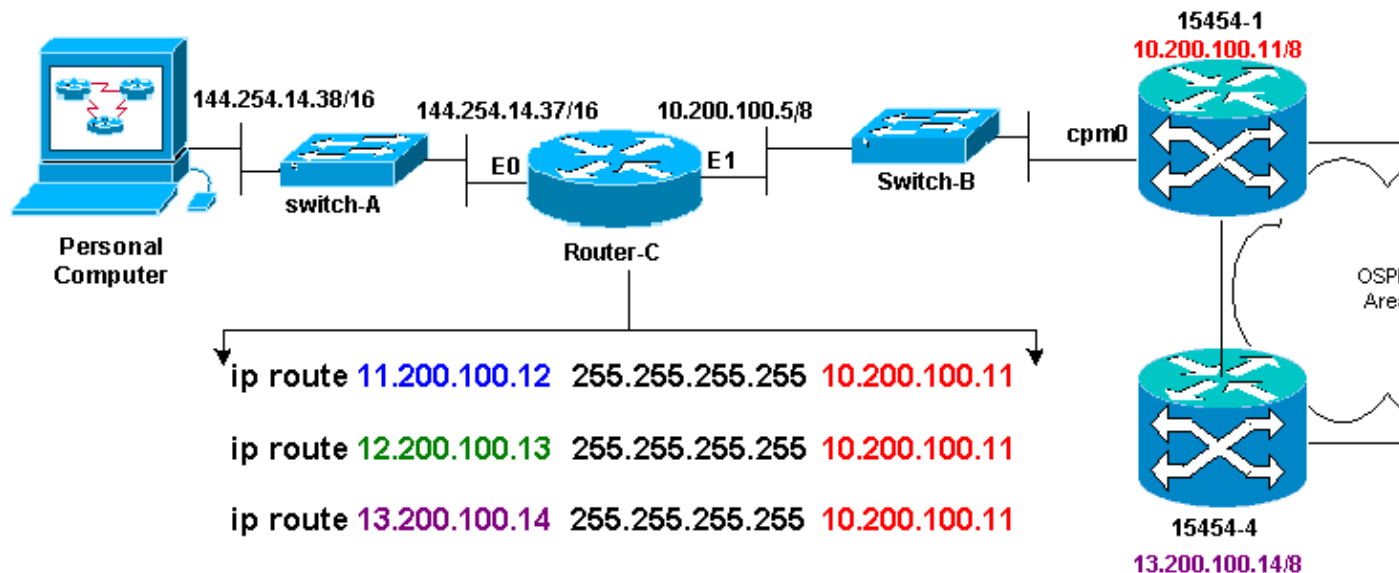

The four nodes in the BLSR form an internal OSPF area, and redistribute the static routes learned among themselves. However, the OSPF area does not advertise the learned routes out of the Ethernet management interface (cpm0) on the TCC card on each of the nodes.

Router-C learns the IP address 10.200.100.11 of 15454-1 because the router sees the node as directly connected. However, the other three class A subnets that form the OSPF area within the BLSR are not directly connected to Router-C, and remain hidden. 15454-1 does not advertise the routes of these nodes out of the cpm0 interface to Router-C.

Note: From Cisco ONS15454 Release 3.3 onwards, Proxy server functionality is available. This functionality allows the Gateway ONS15454 to act as proxy for all nodes behind the gateway. This action alleviates the need for the router to have routes that point to all subnets behind the Gateway ONS15454.

Hence, Router C requires that you configure static routes for the three nodes to which the router is not directly connected. The static routes have the next hop IP address assigned to interface cpm0 on 15454-1 to which Router-C is directly connected. View the static route statements in the configuration of Router C, as shown here:

```

!
hostname Router-C
!
.
.
.
interface Ethernet0
ip address 10.200.100.5 255.0.0.0
!
interface Ethernet1
ip address 144.254.14.37 255.255.0.0
!
.
.
ip route 11.200.100.12 255.255.255.255 10.200.100.11
ip route 12.200.100.13 255.255.255.255 10.200.100.11
ip route 13.200.100.14 255.255.255.255 10.200.100.11
!
!
.

```

```

line con 0
exec-timeout 0 0
password 7 131200
login
line aux 0
line vty 0 4
password 7 010411
login
!
end
Router-C#

```

Figure 10 shows the output from the **show ip route** command on Router-C. Both Ethernet interfaces are directly connected, and the three 15454 nodes that are not directly connected are reachable via static routes.

Figure 10 Output of the show ip route Command on Router-C

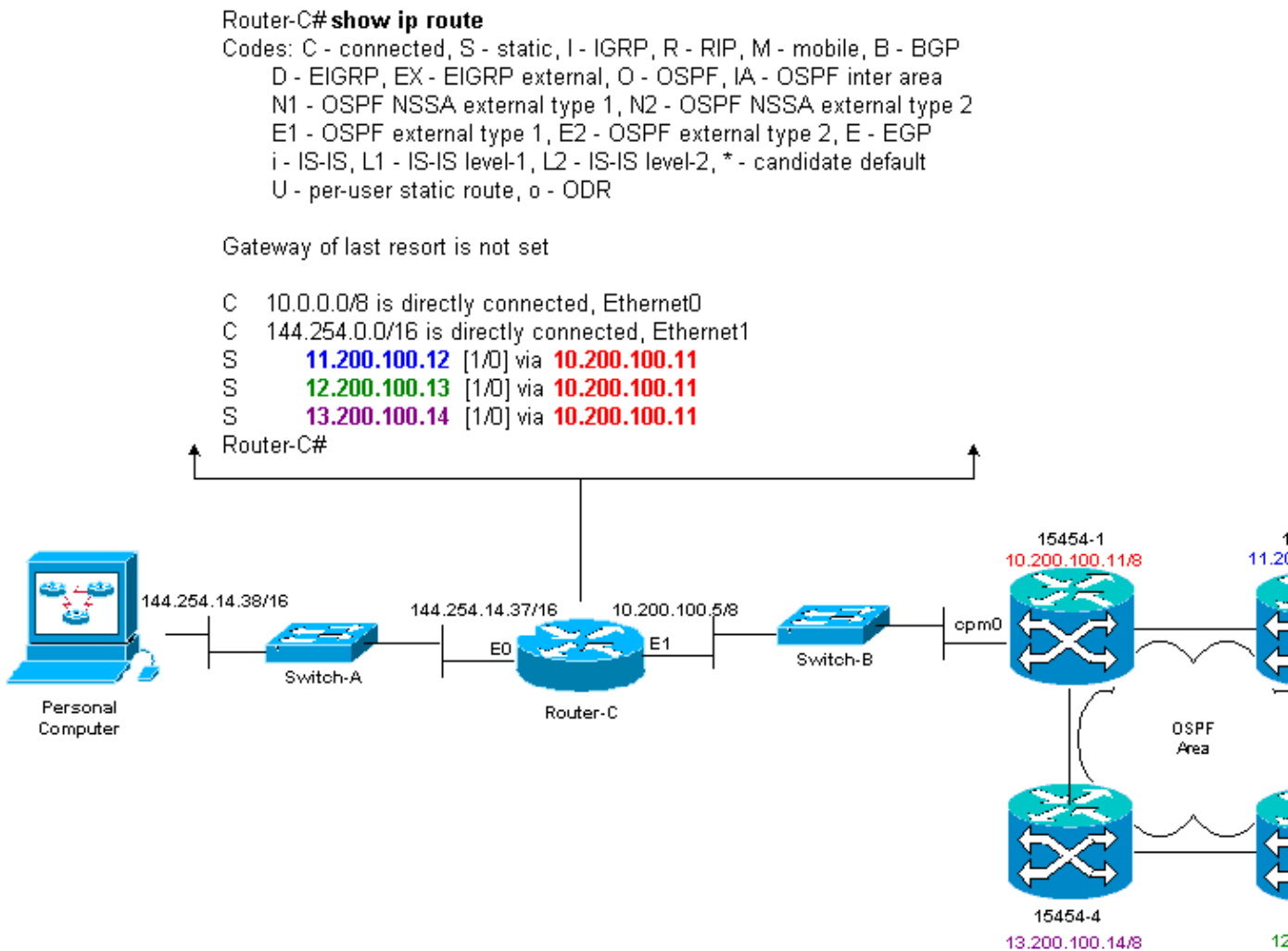

Refer to the IP Routing Scenario 5 section of this document for an example of how to define static routes.

Troubleshoot the Router

Here are the common issues to check for in the enterprise network:

- Verify IP connectivity between the IP subnets of the CTC workstations and the 15454 gateway nodes.

- ◆ Check whether the routers in the enterprise Internet between the CTC workstation and 15454 gateway node have entries in the forwarding table for the CTC workstations IP subnet/major/super net, and the 15454 gateway nodes subnet/major/super net.
- ◆ From router adjacent to 15454 gateway node, perform ping sourced from 15454 gateway nodes default gateway to CTC workstations default gateway.
- Configure static routes for non-gateway 15454 nodes IP address subnet/major/super net in router adjacent to 15454 gateway node:
 - ◆ Ping from the router adjacent to the 15454 gateway node to each 15454 node.

Note: In networks that use the Proxy Server feature, only a SOCKS V5-aware ping application is successful.
- Redistribute static routes into enterprise network:
 - ◆ Check whether static routes are redistributed into enterprise networks dynamic routing protocol or statically configured on each router between CTC workstation and 15454 gateway node?
 - ◆ Ping from the CTC workstation to each 15454 node.

Note: In networks that use the Proxy Server feature, only a SOCKS V5-aware ping application is successful.
- ◆ Verify whether the nodes have a name in CTC map view. In other words, ensure that the nodes are not greyed out with just their IP address showing up.

Troubleshoot the CTC

From the DOS command line prompt on the workstation that runs the CTC application, issue the **ping** command to verify the IP reachability between the workstation and the Ethernet management interface of the TCC card on the 15454. Ping sends Internet Control Management Protocol (ICMP) type eight echo request packets to the destination host IP address you specify. The destination host must reply with ICMP type 0 echo reply packets.

Note: If you run Cisco ONS 15454 Release 3.3 or higher, and use the Proxy Server feature, ping and tracert is successful only to the Gateway NE. You require a SOCKS V5-aware Ping and tracert client to reach any Network Elements (NEs) behind the Gateway NE.

See Figure 11 for a list of the available operands you can specify with the **ping** command:

Figure 11 List of the Available Operands

```
C:\WINNT\System32\cmd.exe
C:\>ping

Usage: ping [-t] [-a] [-n count] [-l size] [-f] [-i TTL] [-u TOS]
          [-r count] [-s count] [[-j host-list] | [-k host-list]]
          [-w timeout] destination-list

Options:
  -t          Ping the specified host until stopped.
              To see statistics and continue - type Control-Break;
              To stop - type Control-C.
  -a          Resolve addresses to hostnames.
  -n count    Number of echo requests to send.
  -l size     Send buffer size.
  -f          Set Don't Fragment flag in packet.
  -i TTL      Time To Live.
  -v TOS      Type Of Service.
  -r count    Record route for count hops.
  -s count    Timestamp for count hops.
  -j host-list Loose source route along host-list.
  -k host-list Strict source route along host-list.
  -w timeout  Timeout in milliseconds to wait for each reply.
```

Use ping to send 10 ICMP type eight echo request packets to the IP address assigned to the Ethernet management interface of the 15454 (10.200.100.11). As you go over Ethernet, also send the requests with the maximum Ethernet packet size of 1500 bytes.

Figure 12 Send 10 ICMP Type Eight Echo Request Packets to 10.200.100.11

```
C:\WINNT\System32\cmd.exe
C:\>
C:\>
C:\>ping 10.200.100.11 -n 10 -l 1500

Pinging 10.200.100.11 with 1500 bytes of data:

Request timed out.
Reply from 10.200.100.11: bytes=1500 time=10ms TTL=63
Reply from 10.200.100.11: bytes=1500 time=10ms TTL=63
Reply from 10.200.100.11: bytes=1500 time=10ms TTL=63
Reply from 10.200.100.11: bytes=1500 time=10ms TTL=63
Reply from 10.200.100.11: bytes=1500 time=10ms TTL=63
Reply from 10.200.100.11: bytes=1500 time<10ms TTL=63
Reply from 10.200.100.11: bytes=1500 time<10ms TTL=63
Reply from 10.200.100.11: bytes=1500 time<10ms TTL=63

Ping statistics for 10.200.100.11:
    Packets: Sent = 10, Received = 9, Lost = 1 (10% loss),
    Approximate round trip times in milli-seconds:
        Minimum = 0ms, Maximum = 10ms, Average = 5ms

C:\>
C:\>
C:\>
```

As you can see, despite a 10% loss that occurs due to the timeout of the echo requests, you can successfully reach the IP address assigned to the Ethernet management interface on the TCC card in the 15454.

In order to verify the path taken to the 15454, issue the **tracert** command from the DOS command line prompt (see Figure 13).

Figure 13 Issue the tracert Command from the DOS Prompt

```
C:\WINNT\System32\cmd.exe
C:\>
C:\>
C:\>
C:\>
C:\>
C:\>
C:\>
C:\>
C:\>tracert

Usage: tracert [-d] [-h maximum_hops] [-j host-list] [-w timeout] target_name

Options:
-d          Do not resolve addresses to hostnames.
-h maximum_hops  Maximum number of hops to search for target.
-j host-list  Loose source route along host-list.
-w timeout      Wait timeout milliseconds for each reply.

C:\>
C:\>
C:\>
C:\>
C:\>
C:\>
C:\>
```

Next, use the **tracert** command to specify the destination IP address (10.200.100.11) assigned to the Ethernet management interface of the TCC card on the 15454.

Figure 14 Specify the Destination IP address of the Ethernet Management Interface

```
C:\WINNT\System32\cmd.exe
C:\>
C:\>
C:\>
C:\>
C:\>
C:\>
C:\>tracert 10.200.100.11

Tracing route to 10.200.100.11 over a maximum of 30 hops

  1    10 ms    <10 ms    <10 ms    144.254.14.37
  2    <10 ms   <10 ms    <10 ms    10.200.100.11

Trace complete.

C:\>
C:\>
C:\>
C:\>
C:\>
C:\>
C:\>
```

Here, you can see that the destination IP address is two hops away. The first hop is 144.254.14.37, which is the IP address assigned to the Ethernet 0 interface of the Ethernet segment to which the CTC workstation is connected. The second hop is 10.200.100.11, which is the IP address assigned to the Ethernet management interface of the TCC card in the 15454.

If you experience IP connectivity problems from the CTC, check for these issues:

- Incorrect IP addresses or subnet mask:

Interfaces on the same network must have IP addresses that are within the same subnet to communicate directly.

- Duplicate IP addresses:

IP addresses must be unique. The network portion can be the same for all addresses but the host

portion must be unique.

- Incorrect or missing default gateway or static route.
- Unexpected IP address on a dual honed PC:

Check whether the CTC application sees an unexpected IP address on a dual honed PC. In other words, check whether you have dual Network Interface Cards (NIC) installed on the PC.

Configure the 15454 IP Parameters Through the Front Panel LCD

You can set up the IP address, subnet mask, and default router addresses of the ONS 15454 through the slot, status, and port buttons on the front panel Liquid Crystal Display (LCD). You can accomplish these basic operations without a computer.

You can lock out the front panel LCD access to network configuration. Click the **Provisioning > Network** tabs in the Node view of CTC. Select the **Prevent LCD IP Config** button, and click **Apply**.

Note: The LCD reverts to normal display mode after 30 seconds of button inactivity.

Figure 15 Front Panel LCD

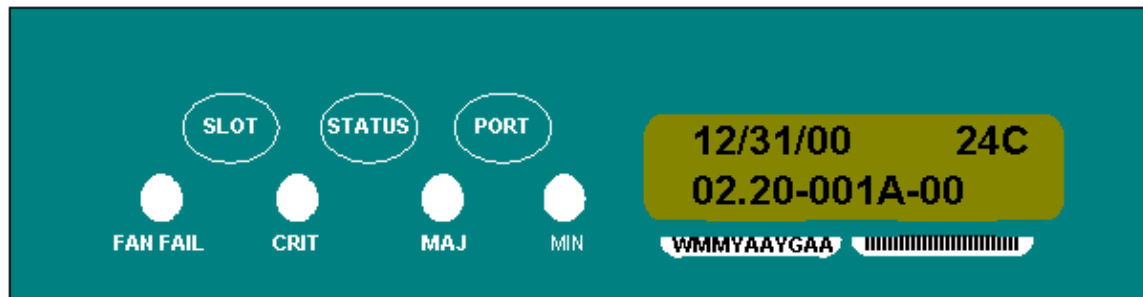

Enter the IP Address From the Front Panel LCD

Complete these steps in order to enter an IP Address through the front Panel LCD:

1. Press the **Slot** button repeatedly until Slot-0 appears on the LCD panel. Slot-0 indicates the Slot-0 menu.
2. Press the **Port** button repeatedly to scroll through the configuration menus until the IP Address option appears.
3. Press the **Status** button.
4. Push the **Slot (Next)** button to move to the IP address digit you need to change. The selected digit flashes.
5. Press the **Port (Modify)** button to cycle the IP address digit to the correct digit.

Figure 16 Modify a Digit in the IP Address

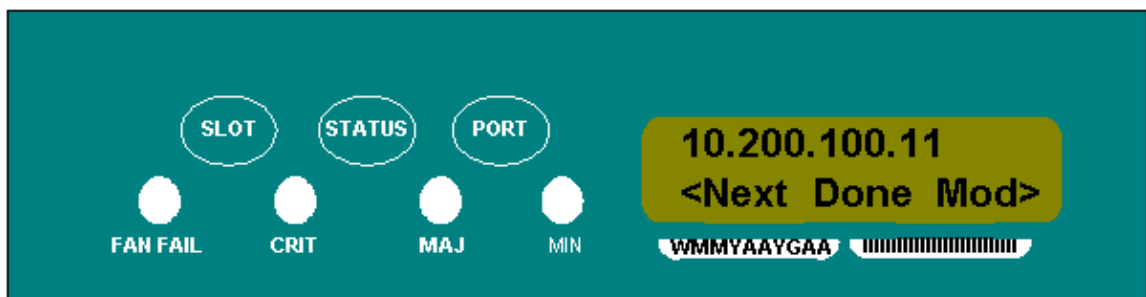

6. Press the **Status (Done)** button to return to the Slot-0 menu, when you have set the required IP address.

Figure 17 Status (Done)

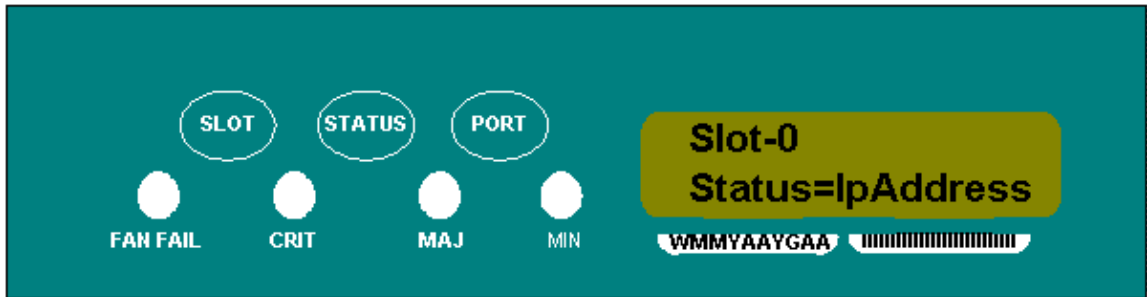

7. Press the **Port** button repeatedly until the **Save Configuration** option appears.

Figure 18 Save Configuration Option

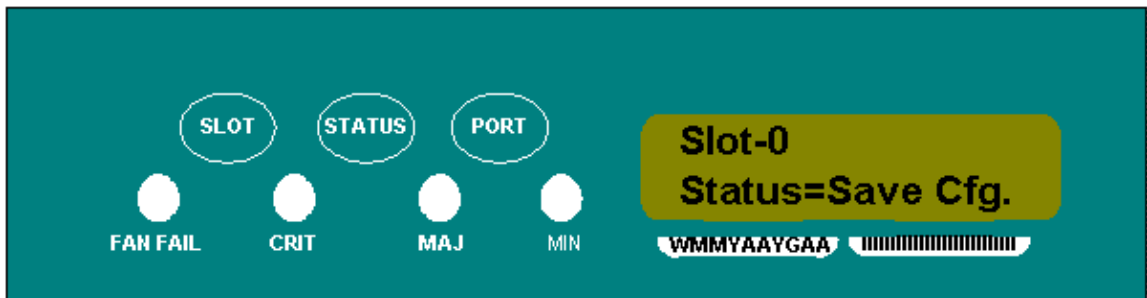

8. Press the **Status** button to select the **Save Configuration** option. The **Save and REBOOT** screen appears.

Figure 19 Save and Reboot

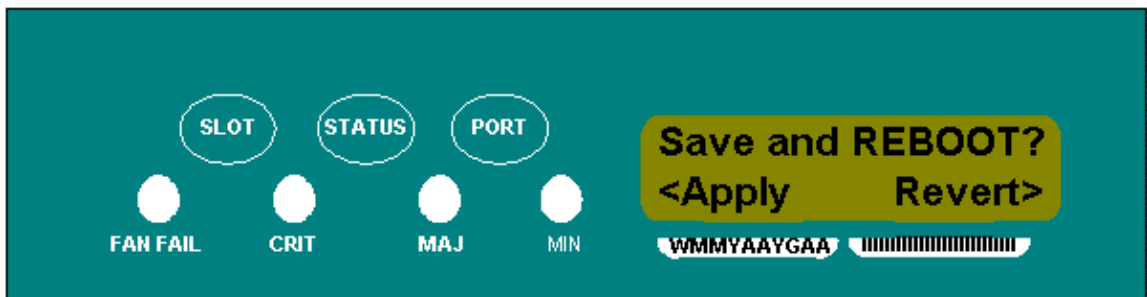

9. Press the **Slot (Apply)** button to save the new IP address configuration.

Figure 20 Slot (Apply)



When you save a new configuration, the TCC cards reboot. The **Saving Changes** LCD appears for several minutes while the TCC cards reboot. When the LCD screen returns to the normal alternating display mode, the procedure is complete.

Common IP Addressing Scenarios for the 15454

15454 IP addressing generally has seven common IP addressing scenarios or configurations. Refer to these illustrations and checklists when you set IP addresses and configure subnets. You must be able to answer with a "yes" to each checklist question to be sure that all you meet all IP addressing guidelines. If you answer with a "no" to any of the questions, you need to see the IPScenario Troubleshooting section of this document.

This section illustrates these seven scenarios and provides an IP checklist for each scenario.

Note: From Release 2.2.0 onwards, LAN devices no longer need host routes to communicate with other ONS 15454s on the same subnet that connect through DCC.

IP Scenario 1

ONS 15454s and CTC are on the same subnet. All ONS 15454s attach to LAN A. If your answer is "no" to any of the questions in the checklist, see the IP Scenario Troubleshooting section of this document.

Figure 21 Scenario 1

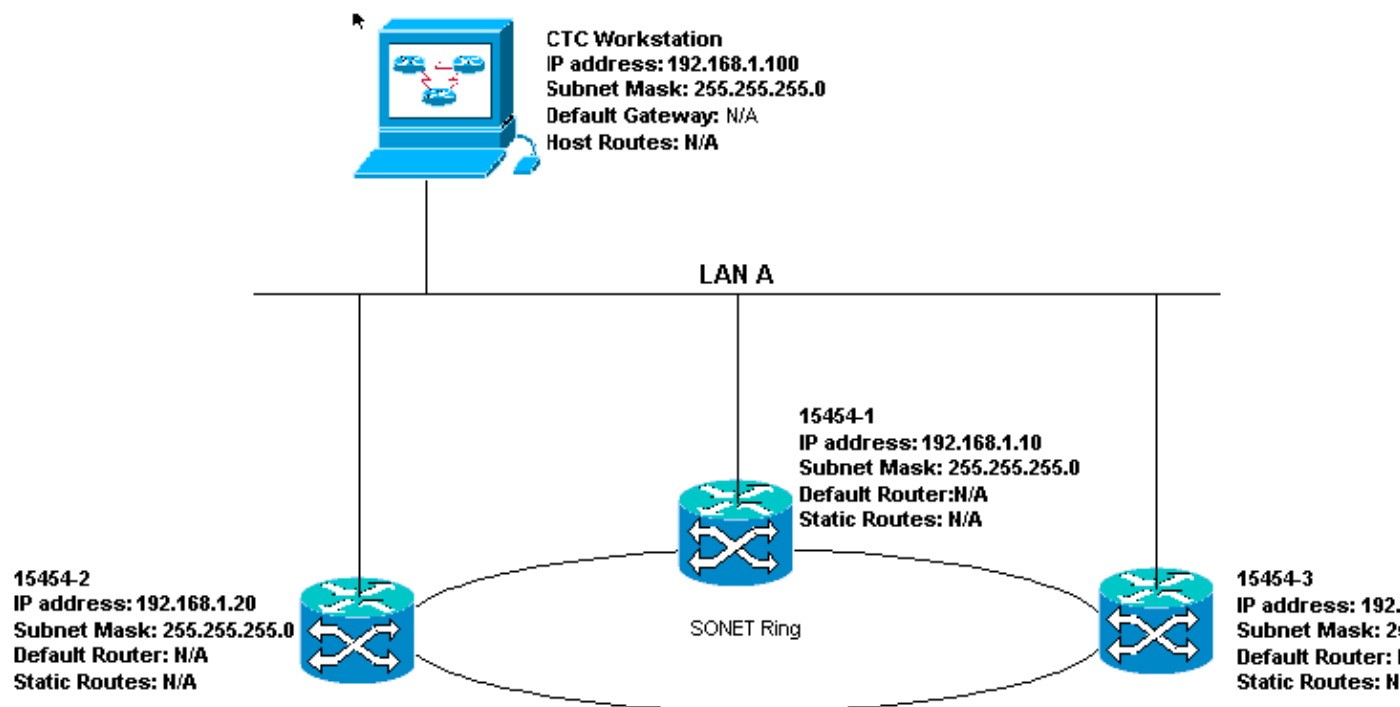

IP Checklist for Scenario 1:

- Are the IP addresses of ONS 15454s #1, #2, and #3 on the same IP subnet?
- Are all the IP addresses unique?
- Can the workstation that runs CTC ping itself?
- Is there link integrity between the CTC workstation and the hub or switch?
- Do the LAN wire-wrap pins on the backplane or TCC's RJ-45 port have link integrity? On all ONS 15454s and the hub or switch?
- Is the hub or switch port for all ONS 15454s set for 10 Mbps half-duplex?

- Can you ping ONS 15454 #1, #2, and #3 from the CTC workstation?
- Do you have a web browser installed (either Netscape Navigator" version 4.08 or higher or Internet Explorer" 4 or higher)?
- Do you have the Java" plug-in installed (version 1.2.2. or higher for Microsoft Windows" and version 1.2.1_03 for Sun Solaris")?
- Do you have the Java" policy file installed?
- Do you use the browser to connect to the IP address of the ONS 15454?
- Can you log into the ONS 15454?

IP Scenario 2

ONS 15454s and CTC are on different subnets. All ONS 15454s attach to LAN B. If your answer is "no" to any of the questions in the checklist, see the IP Scenario Troubleshooting section of this document.

Figure 22 Scenario 2

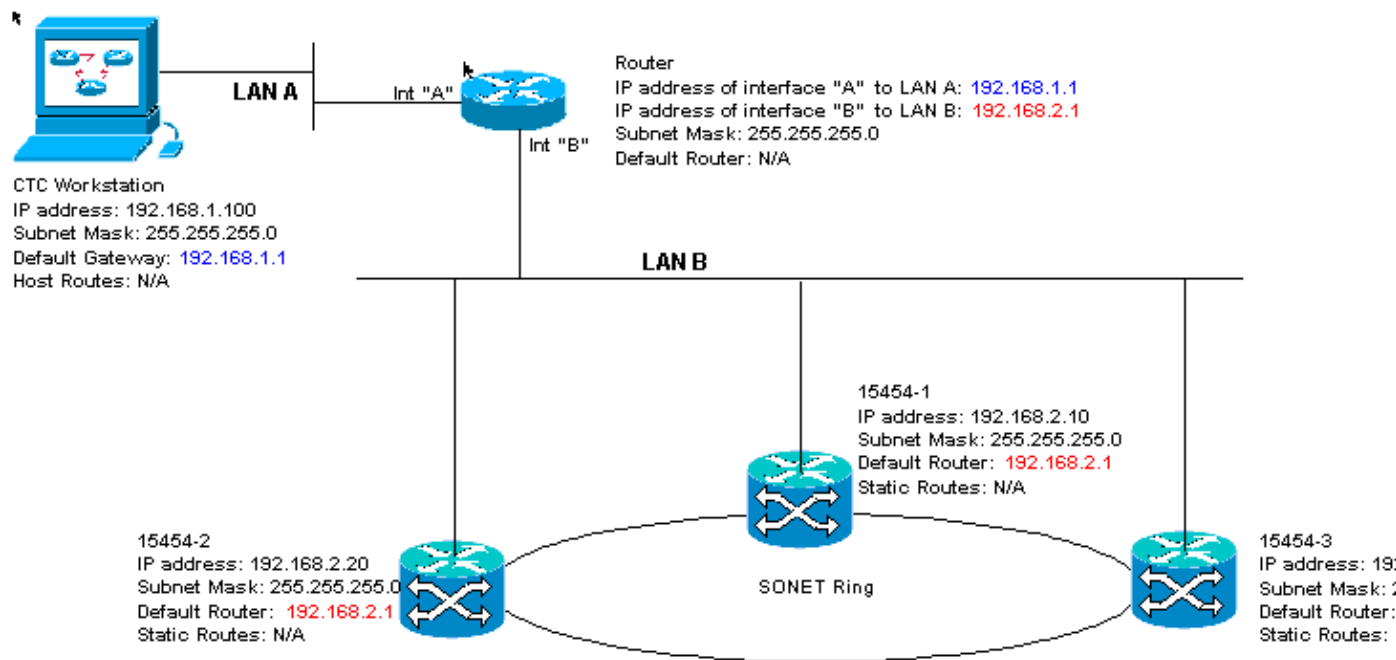

IP Checklist for Scenario 2:

- Is the IP address of the CTC workstation and the router interface A on the same subnet?
- Can the workstation that runs CTC ping itself?
- Is the default gateway of the workstation set to the same IP address as the A interface of the router?
- Are the IP addresses of the ONS 15454 #1, #2, and #3 on the same subnet as the B interface of the router?
- Are all of the IP addresses unique?
- Is the default router of the ONS 15454 #1, #2, and #3 set to the IP address of the interface of router B?
- Is there link integrity between the workstation and the hub or switch?
- Is there link integrity between the LAN wire-wrap pins on the backplane or the TCC's RJ-45 port of all nodes and the hub/switch(es)?
- Is there link integrity between the router ports and their hubs or switches?
- Are the hub or switch ports on all ONS 15454s set for 10 Mbps half-duplex?
- Can you ping ONS 15454 #1, #2 and #3 from the CTC workstation?
- Do you have a web browser installed (either Netscape Navigator" version 4.08 or higher or Internet Explorer" 4 or higher)?

- Do you have the Java" plug-in installed (version 1.2.2 or higher for Microsoft Windows" and version 1.2.1_03 for Sun Solaris")?
- Do you have the Java" policy file installed?
- Do you use the browser to connect to the IP address of the ONS 15454?
- Can you log into the ONS 15454?

IP Scenario 3

CTC and all ONS 15454s are on the same subnet. 15454-1 is attached to LAN A, and 15454-2 and 3 are at remote sites. If your answer is "no" to any of the questions in the checklist, see the IP Scenario Troubleshooting section of this document.

Figure 23 Scenario 3

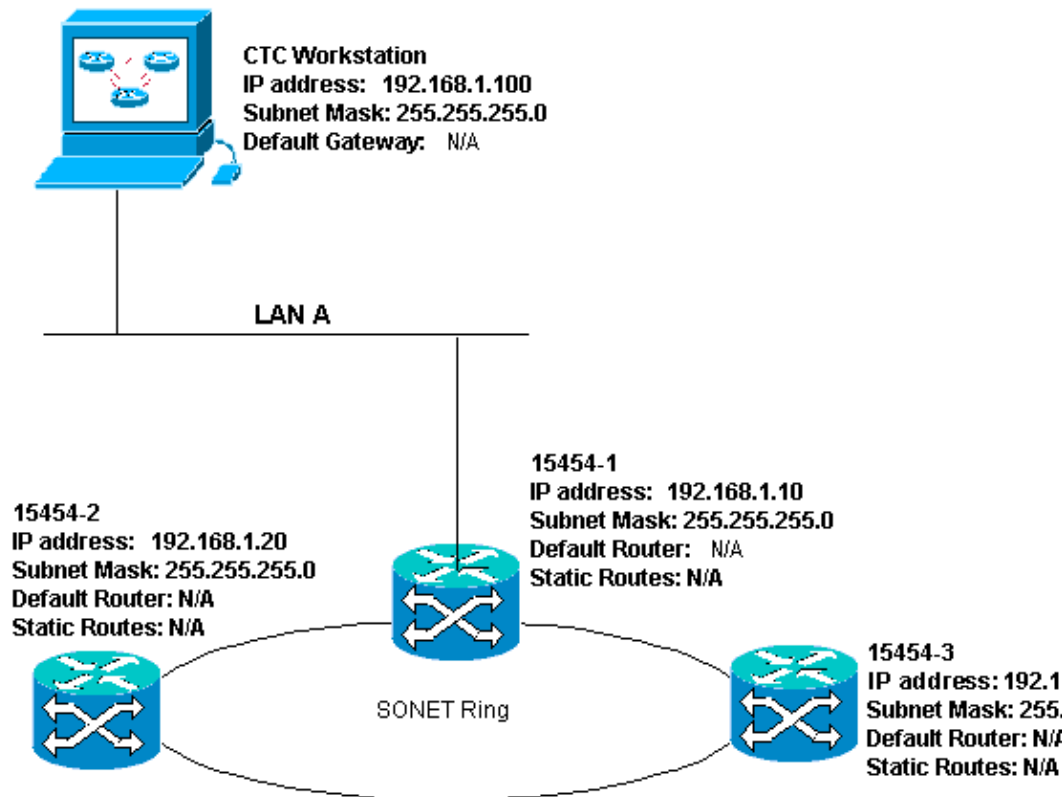

IP Checklist for Scenario 3:

- Is the workstation IP address and the IP address of all ONS 15454s on the same IP subnet?
- Are all of the IP addresses unique?
- Can the workstation that runs CTC ping itself?
- Are host routes configured on the CTC workstation for each remote node (15454-2 and 3)?
- Is there link integrity between the CTC workstation and the hub or switch?
- Is there link integrity between the LAN wire-wrap pins on the backplane or the active TCC RJ-45 port and the hub or switch?
- Is the hub or switch port set for 10 Mbps half-duplex?
- Can you ping ONS 15454 #1 from the CTC workstation?
- Are the optical trunk ports on all nodes in service?
- Is the DCC enabled for all optical trunk ports that are in service?
- Can you ping the remote nodes (ONS 15454 #2 and #3) from the CTC workstation?
- Do you have a web browser installed (either Netscape Navigator" version 4.08 or higher or Internet Explorer" 4 or higher)?

- Do you have the Java" plug-in installed (version 1.2.2 or higher for Microsoft Windows" and version 1.2.1_03 for Sun Solaris")?
- Do you have the Java" policy file installed?
- Do you use the browser to connect to the IP address of the ONS 15454?
- Can you log into the ONS 15454?

IP Scenario 4

CTC and ONS 15454-1 are on the same subnet, while 15454-2 and 3 are on different subnets. 15454-1 is attached to LAN A, and ONS 15454-2 and 3 are at remote sites. If your answer is "no" to any of the questions in the checklist, see the IP Scenario Troubleshooting section of this document.

Figure 24 Scenario 4

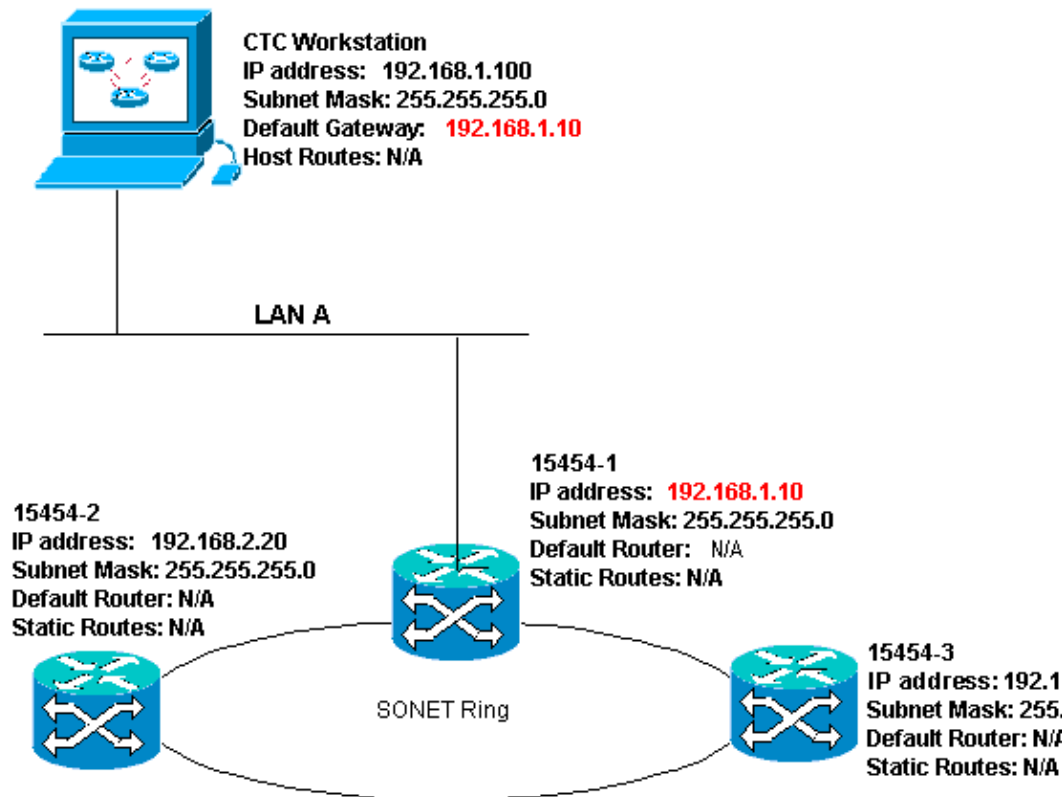

IP Checklist for Scenario 4:

- Is the CTC workstation IP address and the ONS 15454 #1 IP address on the same subnet?
- Are the IP addresses of ONS 15454 #1, #2, and #3 on different subnets?
- Are all of the IP addresses unique?
- Can the workstation that runs the CTC ping itself?
- Is the default gateway of the CTC workstation set to the same IP address as ONS 15454 #1?
- Is there link integrity between the workstation and the hub or switch?
- Is there link integrity between the LAN wire-wrap pins on the backplane or the active TCC RJ-45 port and the hub or switch?
- Is the hub or switch port set for 10 Mbps half-duplex?
- Can you ping ONS 15454 #1 from the CTC workstation?
- Are the optical trunk ports on all nodes in service?
- Is the DCC enabled for all optical trunk ports that are in service?
- Can you ping the remote nodes (ONS 15454 #2 and #3) from the CTC workstation?

- Do you have a web browser installed (either Netscape Navigator™ version 4.08 or higher or Internet Explorer™ 4 and higher)?
- Do you have the Java™ plug-in installed (version 1.2.2 or higher for Microsoft Windows™ and version 1.2.1_03 for Sun Solaris™)?
- Do you have the Java™ policy file installed?
- Do you use the browser to connect to the IP address of the ONS 15454?
- Can you log into the ONS 15454?

IP Scenario 5

CTC and each of the 15454s are on different subnets. 15454-1 is attached to LAN A, and ONS 15454-2 and 3 are at remote sites. If your answer is "no" to any of the questions in the checklist, see the IP Scenario Troubleshooting section of this document.

Figure 25 Scenario 5

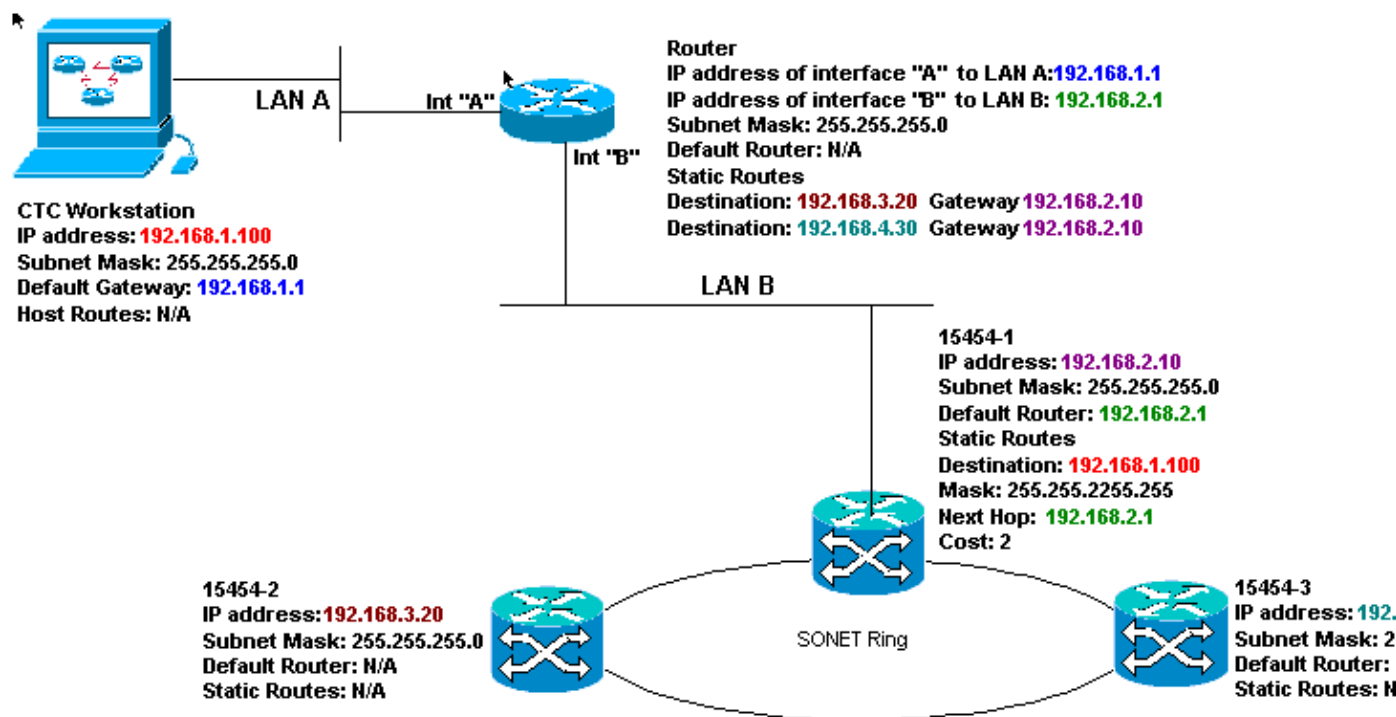

IP Checklist for Scenario 5:

- Is the IP address of the CTC workstation and the A interface of the router on the same subnet?
- Can the workstation that runs the CTC ping itself?
- Is the default gateway of the workstation set to the IP address of the A interface of the local router?
- Are the IP addresses of ONS 15454 #1, #2, and #3 on the different subnets?
- Are all of the IP addresses unique?
- Is the Default Router of ONS 15454 #1 set to the same IP address as the B interface of the router?
- Does ONS 15454 #1 have static routes that point to the CTC workstation?
- Does the router have host routes configured for all the remote ONS 15454s?
- Is there link integrity between the workstation and the hub or switch?
- Is there link integrity between the LAN wire-wrap pins on the backplane or the TCC RJ-45 ports and the hub or switch?
- Is there link integrity between the router ports and their hubs or switches?
- Is the hub or switch port for ONS 15454 #1 set for 10 Mbps half-duplex?
- Can you ping ONS 15454 #1 from the CTC workstation?

- Are the optical trunk ports on all nodes in service?
- Is the DCC enabled for all optical trunk ports that are in service?
- Can you ping the remote nodes (ONS 15454 #2 and #3) from the CTC workstation?
- Do you have a web browser installed (either Netscape Navigator™ version 4.08 or higher or Internet Explorer 4™ and higher)?
- Do you have the Java™ plug-in installed (version 1.2.2 or higher for Microsoft Windows™ and version 1.2.1_03 for Sun Solaris™)?
- Do you have the Java™ policy file installed?
- Do you use the browser to connect to the IP address of the ONS 15454?
- Can you log into the ONS 15454?

IP Scenario 6

CTC is on a different subnet and all 15454s are on the same subnet. 15454-1 is attached to LAN A, and 15454-2 and 3 are at remote sites. If your answer is "no" to any of the questions in the checklist, see the IP Scenario Troubleshooting section of this document.

Figure 26 Scenario 6

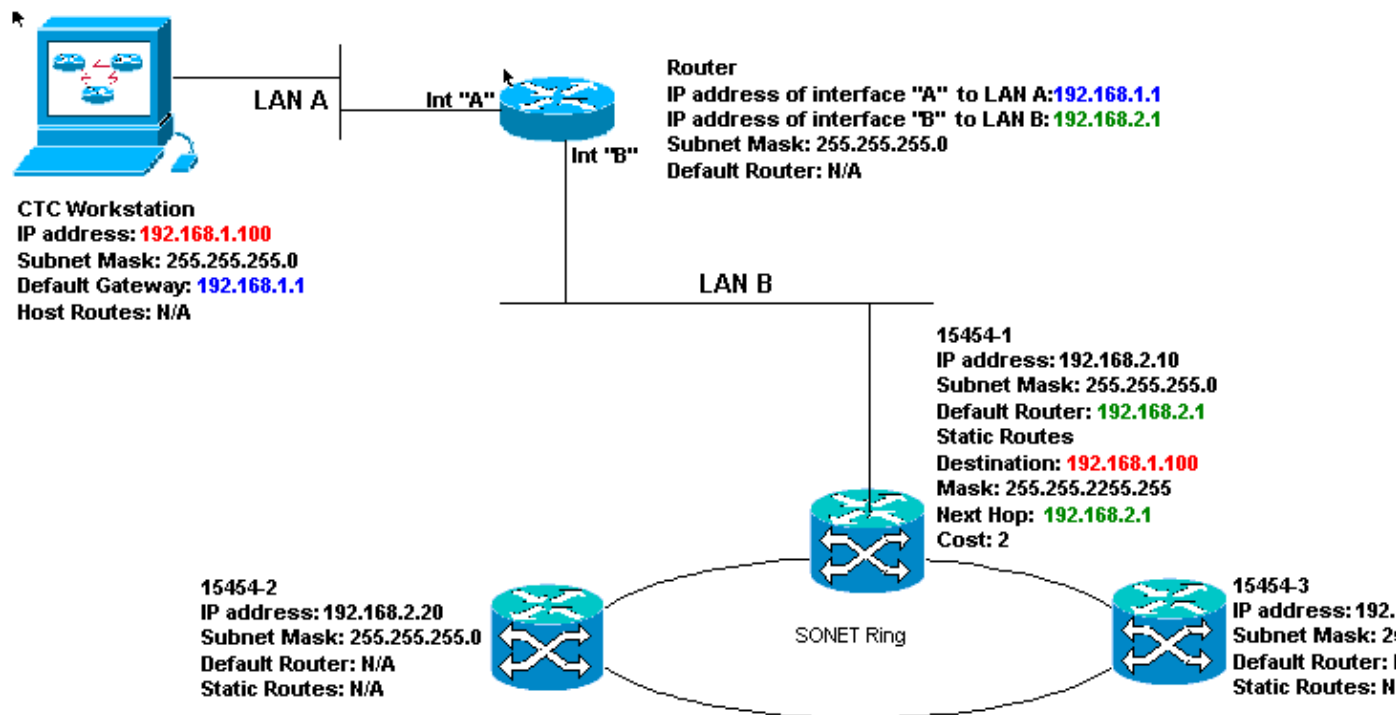

IP Checklist for Scenario 6:

- Is the IP address of the CTC workstation and the router A interface on the same subnet?
- Can the workstation that runs the CTC ping itself?
- Is the default gateway of the workstation set to the same IP address as the A interface of the local router?
- Are the IP addresses of ONS 15454 #1, #2, and #3 on the same subnet as the B interface of the local router?
- Are all of the IP addresses unique?
- Is the default router of ONS 15454 #1 set to the IP address of the B interface of the router?
- Is there link integrity between the workstation and the hub or switch?
- Is there link integrity between the LAN wire-wrap pins on the backplane or the TCC RJ-45 port and the hub or switch?
- Is there link integrity between the router ports and their hubs or switches?

- Is the hub or switch port for ONS 15454 #1 set for 10 Mbps half-duplex?
- Can you ping ONS 15454 #1 from the CTC workstation?
- Are the optical trunk ports on all nodes in service?
- Is the DCC enabled for all optical trunk ports that are in service?
- Can you ping the remote nodes (ONS 15454 #2 and #3) from the CTC workstation?
- Do you have a web browser installed (either Netscape Navigator™ version 4.08 or higher or Internet Explorer™ 4 and higher)?
- Do you have the Java™ plug-in installed (version 1.2.2 or higher for Microsoft Windows™ and version 1.2.1_03 for Sun Solaris™)?
- Do you have the Java™ policy file installed?
- Do you use the browser to connect to the IP address of the ONS 15454?
- Can you log into the ONS 15454?

IP Scenario 7

CTC 1 and 2 and all 15454s are on the same IP subnet. ONS 15454-1 and CTC 1 are attached to LAN A. ONS 15454-2 and CTC 2 are attached to LAN B. If your answer is "no" to any of the questions in the checklist, see the IP Scenario Troubleshooting section of this document.

Figure 27 Scenario 7

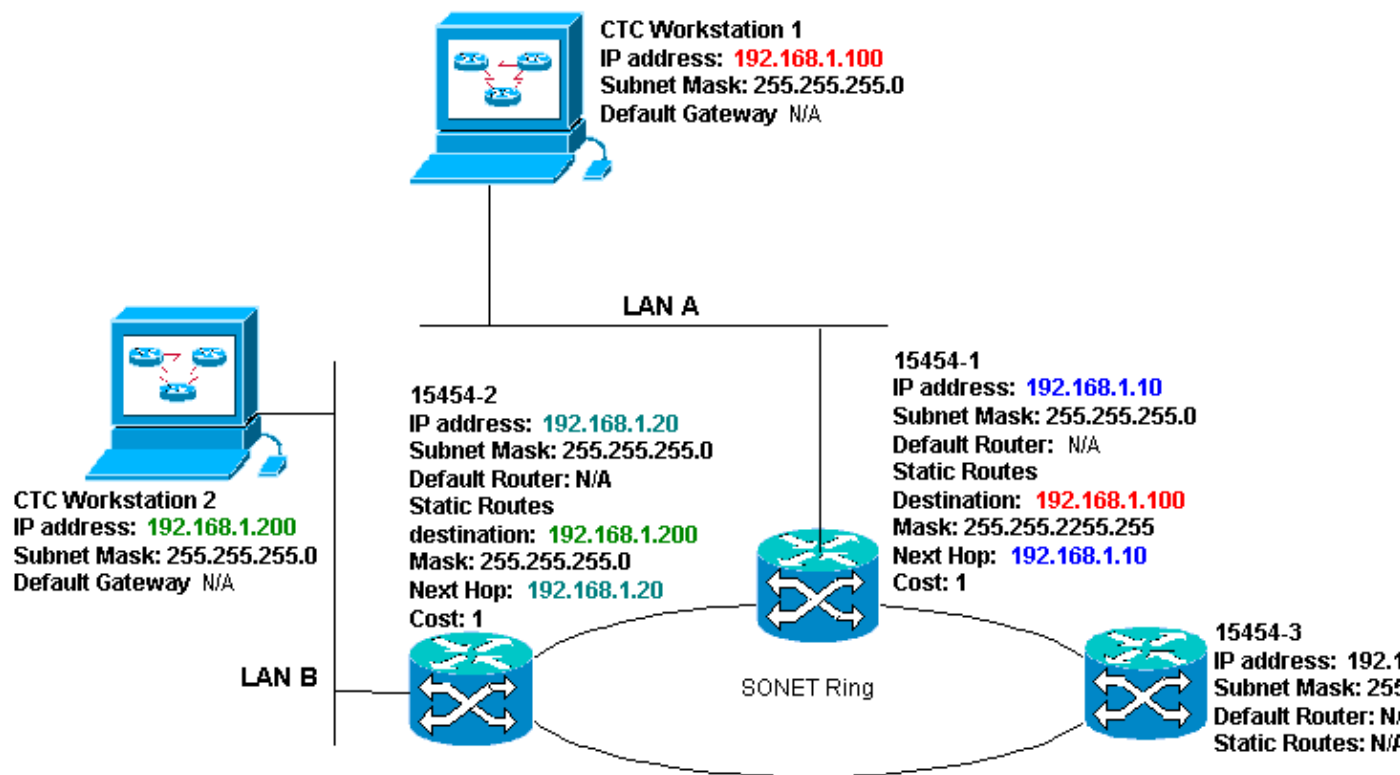

IP Checklist for Scenario 7:

- Are the two CTC workstations IP addresses and all the ONS 15454s IP addresses on the same subnet?
- Are all of the IP addresses unique?
- Does ONS 15454 #1 have static routes that point to CTC workstation #1?
- Does ONS 15454 #2 have static routes that point to CTC workstation #2?
- Can the workstation that runs the CTC ping itself?
- Is there link integrity between the workstation and the hub or switch?
- Is there link integrity between the wire-wrap pins on the backplane (or the active TCC) and the hub

or switch?

- Is the hub or switch port set for 10 Mbps half-duplex?
- Can you ping ONS 15454 #1 from the CTC workstation?
- Are the optical trunk ports on all nodes in service?
- Is the DCC enabled for all optical trunk ports that are in service?
- Can you ping the remote nodes (ONS 15454 #2 and #3) from the CTC workstation?
- Do you have a web browser installed (either Netscape Navigator" version 4.08 or higher or Internet Explorer" 4 and higher)?
- Do you have the Java" plug-in installed (version 1.2.2 or higher for Microsoft Windows" and version 1.2.1_03 for Sun Solaris")?
- Do you have the Java" policy file installed?
- Do you use the browser to connect to the IP address of the ONS 15454?
- Can you log into the ONS 15454?

IP Scenario Troubleshooting

Look for solutions in this section if you answered "no" to any of the questions in the IP scenarios checklists, or encountered any IP problems.

Problem	Solution
The workstation that runs the CTC cannot ping itself.	<ul style="list-style-type: none">• Verify the IP address of your workstation.• If you are unable to ping, there is a problem with your workstation. Contact the network administrator.
There is no link integrity between the workstation and the hub or switch.	<ul style="list-style-type: none">• Verify whether you use a straight-through Ethernet cable.• Verify whether there is a link-integrity indicator for the port on the hub or switch.• Change the Ethernet cable.• Confirm that the hub or switch port is enabled.• Verify wire-wrap connection.• Contact the network

	<p>administrator.</p>
<p>No link integrity exists between the hub or switch and the LAN wire-wraps or RJ-45 port of the ONS 15454.</p>	<ul style="list-style-type: none"> • Verify that you use a crossover Ethernet cable. • Change the Ethernet cable. • Confirm that the hub/switch port is enabled. • Verify wire-wrap connection. • Contact the network administrator.
<p>You do not know if the hub or switch port that connects to the ONS 15454(s) is properly set at 10 Mbps half-duplex.</p>	<ul style="list-style-type: none"> • Contact the network administrator.
<p>Although the workstation can ping other devices successfully, the workstation cannot ping a specific 15454.</p>	<ul style="list-style-type: none"> • Verify whether the IP address of ONS 15454 specified on the workstation matches the IP address that appears on the 15454 LCD screen. • Check the routing of the workstation, router, and any CTC static routes. • Check whether the optical card ports are in service and have DCC enabled.
<p>The Java" policy file was not installed or the file was installed before the Java" plug-in.</p>	<ul style="list-style-type: none"> • The policy file and installation instructions are available on the software CD that accompanies every 15454.
<p>You do not know whether the IP</p>	

<p>addresses of ONS 15454s #X, #Y and #Z lie on the same or different subnets.</p>	<ul style="list-style-type: none"> • Contact the network administrator.
<p>You do not know whether the default router entry for the ONS 15454 is set correctly to match the IP address of the next hop router's interface.</p>	<ul style="list-style-type: none"> • With the help of the CTC, verify whether the default router configuration specified on the 15454 matches the verified IP address of the next hop router's interface. • See the Static Route Provisioning section of this document. • Is there link integrity between the ports on the router and the hubs or switches? • Contact the network administrator to verify the IP address of the interface of the next hop router.
<p>No link integrity exists between the router ports and the hub or switches.</p>	<ul style="list-style-type: none"> • Contact the network administrator.
<p>You do not know if the optical trunk ports on the 15454s are in service.</p>	<ul style="list-style-type: none"> • Verify whether trunk ports are in service through the CTC. Complete these steps: <ol style="list-style-type: none"> 1. Click the Provisioning tab. 2. Click the Line subtab. 3. Click Status column.

	<p>4. Verify the ports are set to In Service (IS).</p>
<p>You do not know if the DCC is enabled on in-service optical trunk ports.</p>	<ul style="list-style-type: none"> • Verify whether DCC is enabled through the CTC. Complete these steps: <ol style="list-style-type: none"> 1. Go to the card level view of the optical card. 2. Click the Provisioning tab. 3. Click the Sonet DCC subtab. 4. Verify that the optical cards are listed.
<p>The web browser does not connect to the 15454, but connects successfully to other sites.</p>	<ul style="list-style-type: none"> • Verify whether the IP address of the 15454 specified on the workstation matches the IP address that appears on the LCD screen of the ONS 15454. • Confirm that the workstation can ping the ONS 15454.
<p>You are unable to ping remote ONS 15454s.</p>	<ul style="list-style-type: none"> • Verify whether the IP address of ONS 15454 specified on the workstation

matches the IP addresses that appear on the LCD screen of the remote ONS 15454s.

- Check the routing of the ONS 15454 and the workstation.
- If the remote 15454 nodes are on separate subnets, check if there is a static route from the gateway 15454 node to the CTC workstation.
- Ensure that Proxy Server is NOT enabled. If Proxy server is enabled, use a SOCKS V5-aware ping application.

Related Information

- [ONS 15454 Procedure Guide Release 8 – Set Up CTC Network Access](#)
- [Cisco ONS 15400 Series Technical References](#)
- [Technical Support & Documentation – Cisco Systems](#)

[Contacts & Feedback](#) | [Help](#) | [Site Map](#)

© 2014 – 2015 Cisco Systems, Inc. All rights reserved. [Terms & Conditions](#) | [Privacy Statement](#) | [Cookie Policy](#) | [Trademarks of Cisco Systems, Inc.](#)

Updated: Jul 25, 2007

Document ID: 6113
