

Cisco GS7000 High-Output 4-Way Segmentable Node with 42/54 MHz Split

The Cisco® GS7000 High-Output Segmentable Node with 42/54 MHz Split is the latest-generation 1-GHz optical node platform designed to support fiber deep applications of up to 60 dBmV. This platform allows independent segmentation and redundancy for both the forward and reverse paths in a reliable, easily configurable, technician-friendly package.

The forward path of the Cisco GS7000 4-Way Segmentable Node launch amplifier can be initially deployed in nonsegmented mode with a single broadcast optical receiver distributing common RF services to either four output ports (all high level) or six output ports (two high level and four lower level). The forward path can also be fully segmented by using four independent optical receivers that each feeds its own output port, or left/right segmented by using two independent optical receivers that each feeds half of the node's output ports. Forward path optical redundancy is also supported using optional redundant optical receivers. The type of forward path segmentation and/or redundancy is determined by the type of Cisco GS7000 Forward Configuration Module installed.

The Cisco GS7000 Node's reverse path is equally flexible. Reverse traffic can be segmented or combined and routed to a maximum of four Fabry-Perot (FP), distributed feedback (DFB), coarse wavelength-division multiplexing (CWDM), or dense wavelength-division multiplexing (DWDM) reverse optical transmitters, or to the Cisco GS7000 Enhanced Digital Reverse (EDR) optical transmitters as part of the EDR system. Reverse path optical redundancy is supported using optional redundant optical transmitters. The type of reverse path segmentation and/or redundancy is determined by the type of Cisco GS7000 Reverse Configuration Module installed. A Reverse Input Port is also provided for high-frequency (5-210 MHz) reverse signal injection.

All optical transmitters and optical receivers used in the Cisco GS7000 platform have new high-profile module covers that include both a self-contained fiber pigtail storage area and an integrated pull ring for easier module installation and removal. Additionally, the GS7000 optical receiver has a new low-current design that dissipates less power, and incorporates a two-state interstage RF attenuator switch for performance optimization.

Figure 1. Cisco GS7000 High-Output 4-Way Segmentable Node with 42/54 Split



Features

- Six-port 1-GHz RF platform
- Gallium nitride (GaN) gain stages
- Standard accessories in the Cisco GainMaker[®] style (for example, attenuator pads, equalizers, diplexers, and crowbar)
- Field-accessible plug-in forward interstage linear equalizers, forward and reverse configuration modules, and signal directors
- Three-state reverse switch (on/off/6-dB) allows each reverse input to be isolated for noise and ingress troubleshooting (status monitoring or local control module required)
- Auxiliary reverse injection (5-210 MHz) configurable on up to two ports
- Positions for up to four optical receivers and four optical transmitters in housing lid
- Optional low-cost local control module may be installed with a redundant forward configuration module to allow optical path redundancy when no status monitor is required
- Optional status monitoring using a DOCSIS transponder (using standard HMS MIBs)
- Fiber entry ports on both ends of housing lid
- Fiber management tray and track provides easy access to fiber connections
- Primary and redundant power supplies with passive load sharing
- Spring-loaded seizure assemblies allow coaxial connectors to be installed or removed without removing amplifier chassis
- Dual/split AC power

Node Block Diagrams

Figures 2, 3, and 4 provide block diagrams of different node configurations.

Figure 2. Block Diagram: Nonsegmented Node

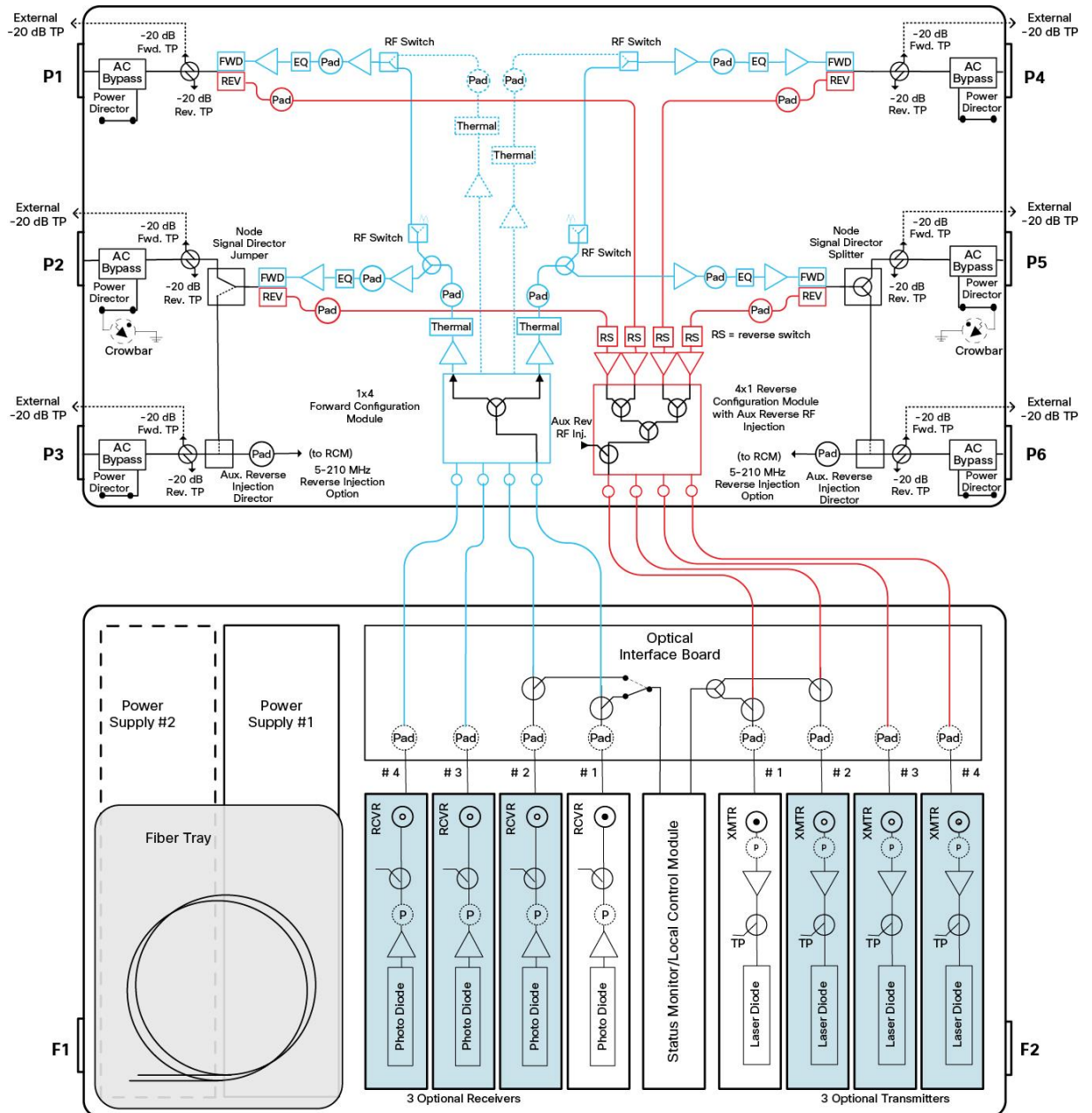

Figure 3. Block Diagram: Left/Right Segmented Node

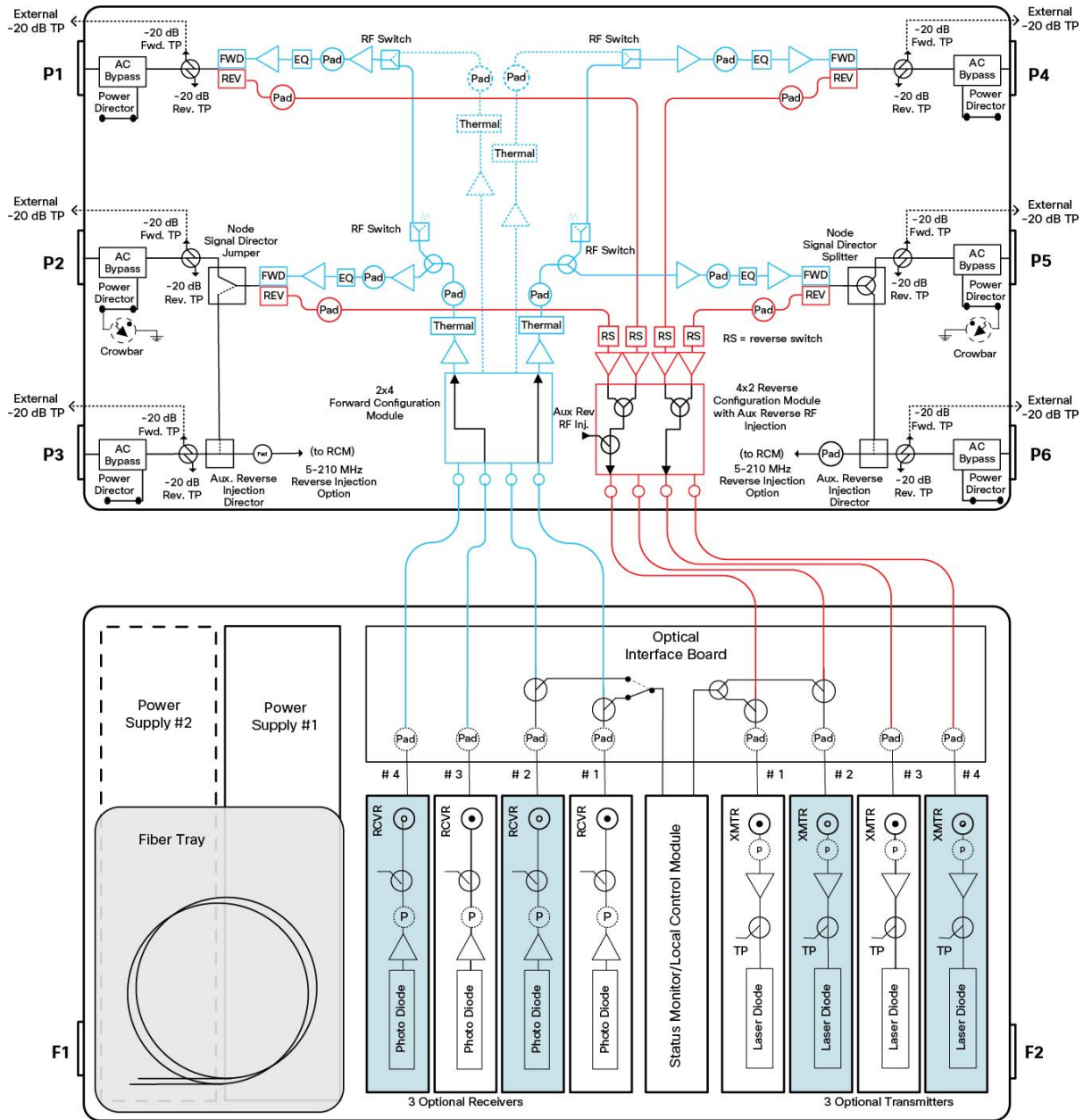
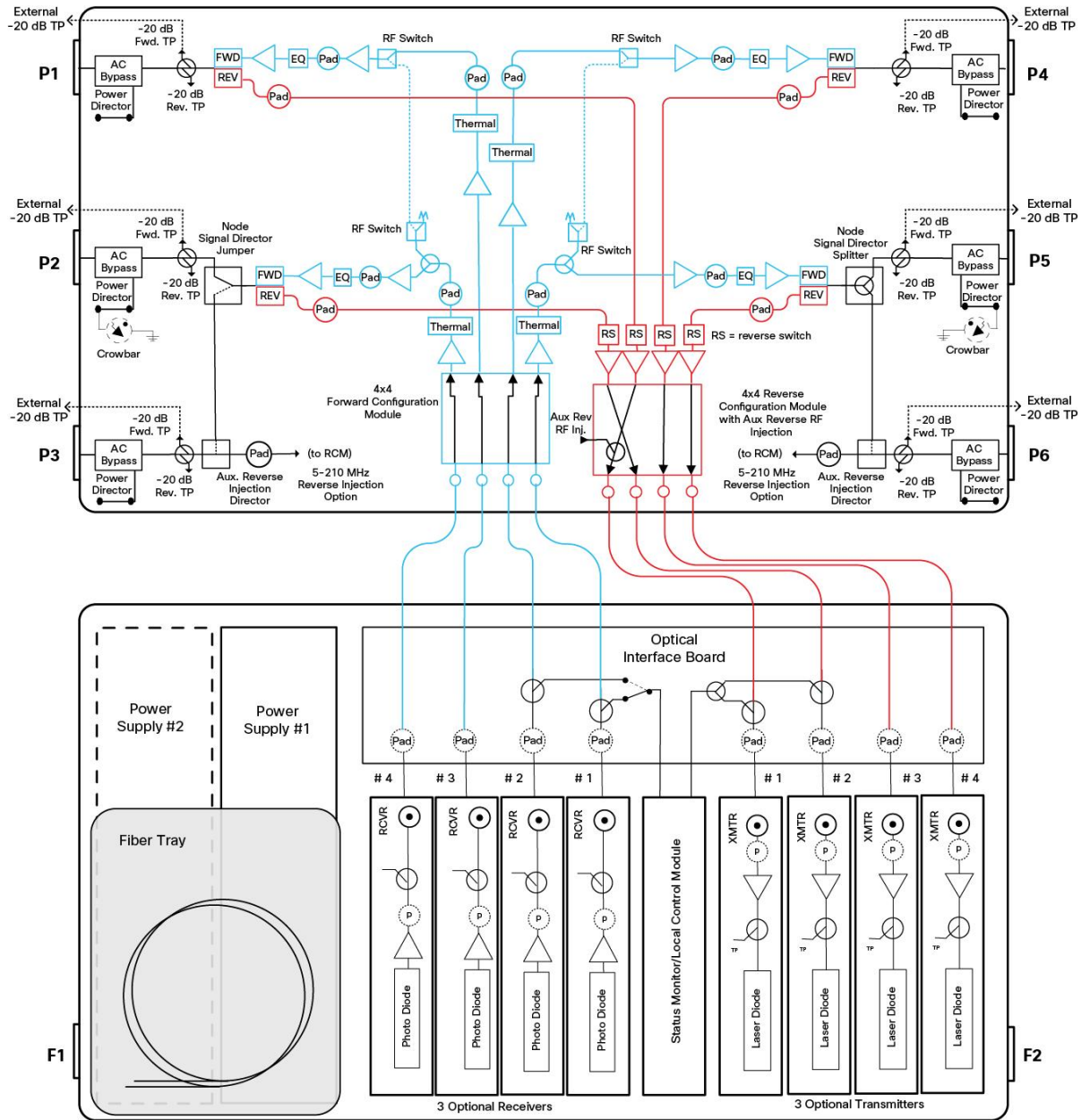

Figure 4. Block Diagram: Fully Segmented Node



Configuration Module Block Diagrams

Figures 5 and 6 provide block diagrams of forward and reverse configuration modules.

Figure 5. Block Diagrams: Forward Configuration Modules

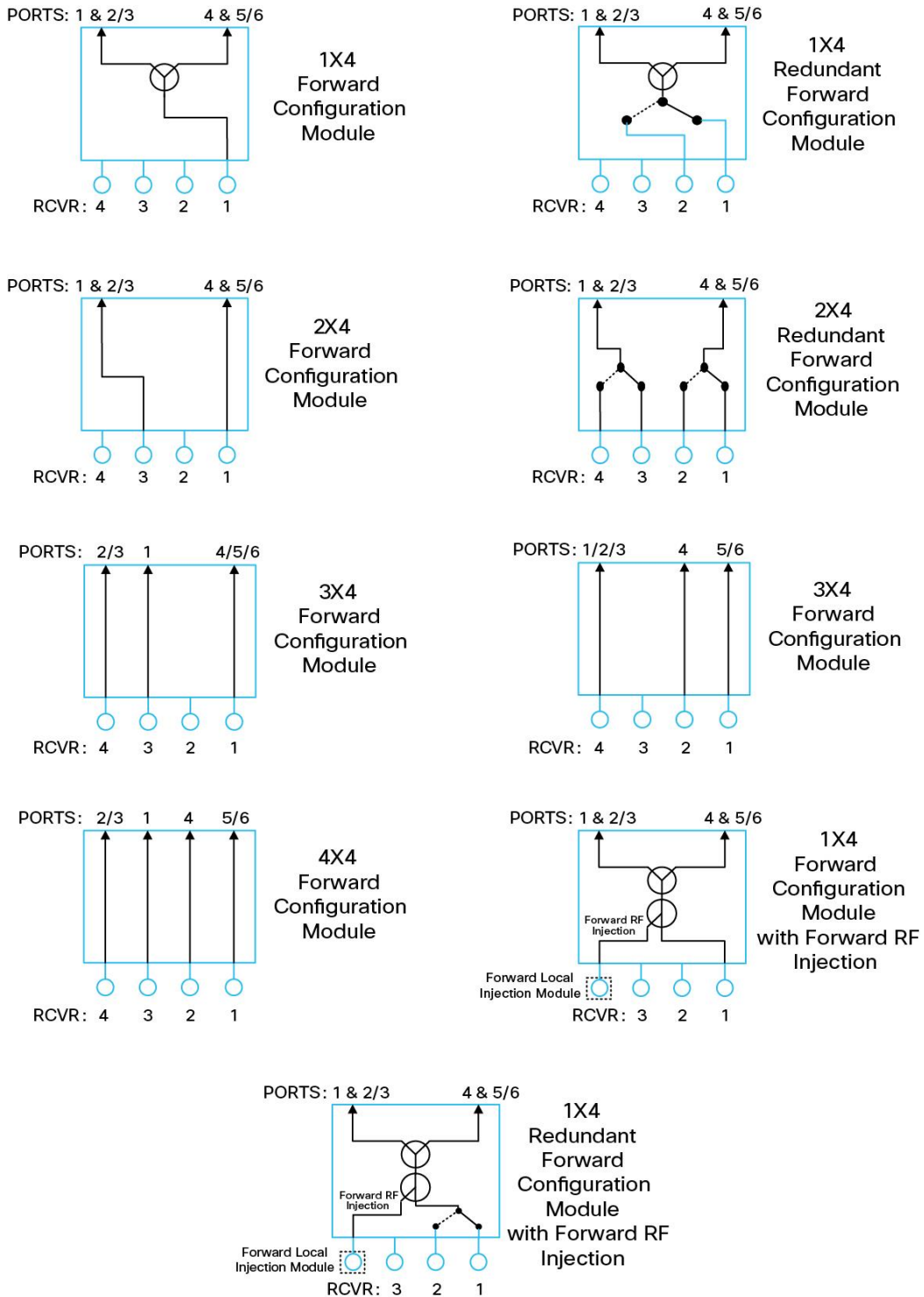
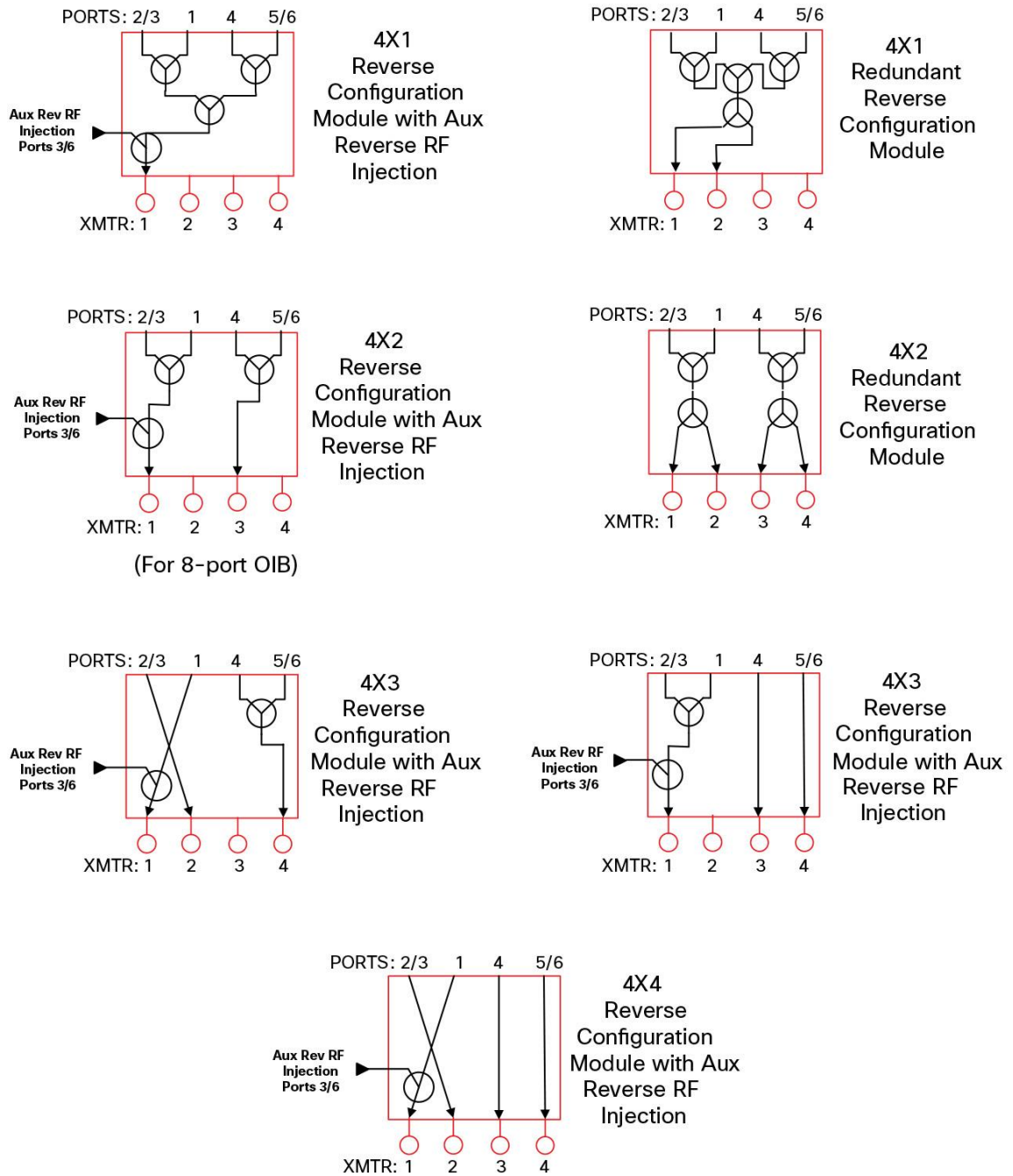

Figure 6. Block Diagrams: Reverse Configuration Modules



Optical Section Specifications

Table 1. Specifications for Optical Section of Forward Receiver Module

Optical Section: Forward Receiver Module	Units	GS7000 Standard RX	GS7000 Low Input RX	Notes
Wavelength	nm	1310 and 1550	1310 and 1550	
Optical input range	mW dBm	0.5 to 1.6 -3 to +2	0.25 to 0.79 -6 to -1	1, 2
Pass band	MHz	52-1002	52-1002	
Frequency response	dB	± 0.5	± 0.5	3
Tilt (±1.0 dB)	dB	0	0	
Optical input test point (±10%)	VDC	1V/mW	1V/mW	
Redundant optical Rx switching threshold (± 1.0 dB)	dBm	-6	-6	
Rx RF output level at 0 dBm optical Rx power	dBmV	Refer to Figures 7 and 8 (below)	Refer to Figures 9 and 10 (below)	4
Rx RF output test point (± 1.0 dB)	dB	- 20	- 20	

Figure 7. Standard Receiver RF Output Level and Transmitter OMI: Rx Switch in -6 dB Setting

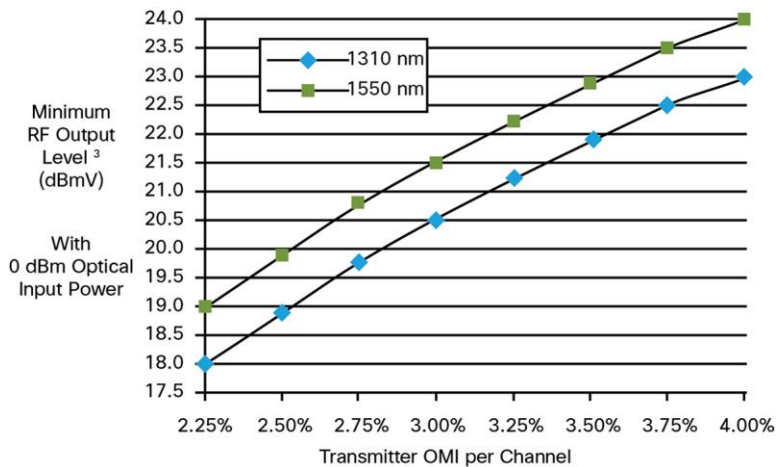

Figure 8. Standard Receiver RF Output Level and Transmitter OMI: Rx Switch in 0 dB Setting

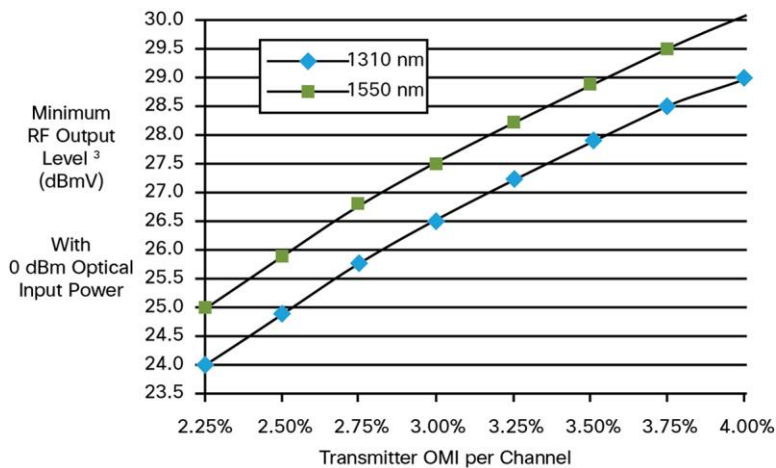

Figure 9. Low Input Receiver RF Output Level and Transmitter OMI: Rx Switch in 0 dB Setting

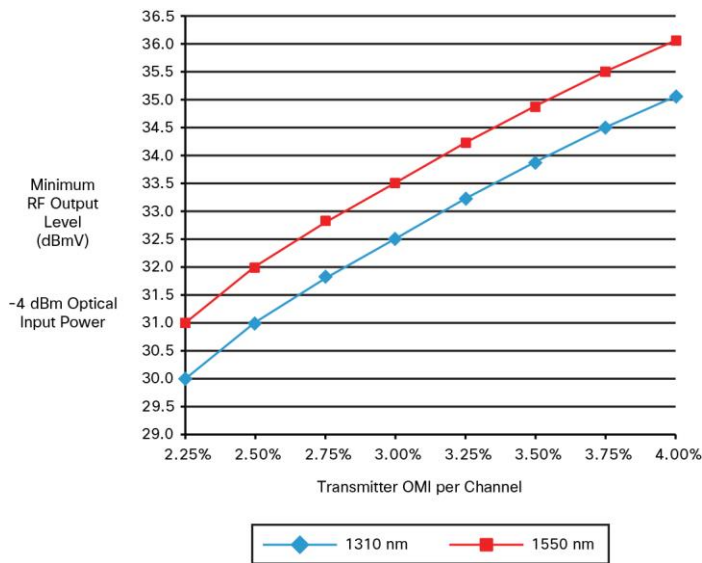
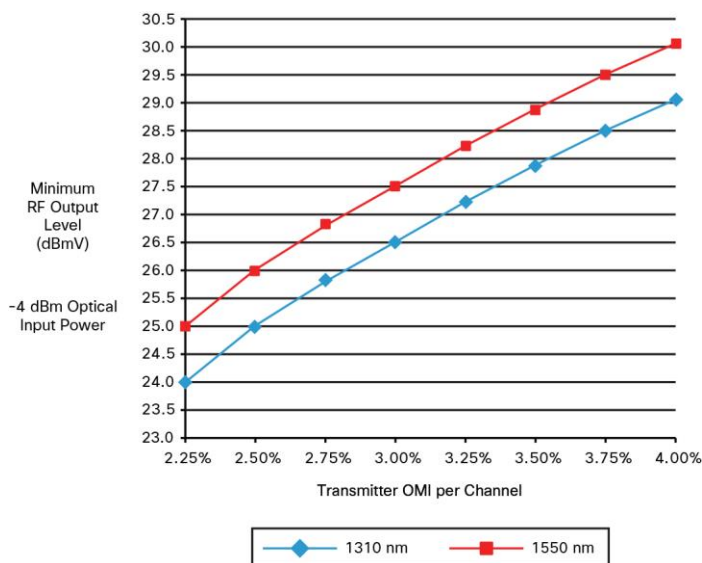

Figure 10. Low Input Receiver RF Output Level and Transmitter OMI: Rx Switch in -6 dB Setting



Notes for Optical Section Specifications:

1. Standard Receiver (Rx) has a 2-position RF attenuator switch (-6 dB and 0 dB). The -6 dB setting is used for greater than 0 to +2 dBm optical Rx power, the 0 dB setting is used for -3 to 0 dBm Rx power.
2. Low Input Receiver (Rx) has a 2-position RF attenuator switch (-6 dB and 0 dB). The -6 dB setting is used for greater than -4 to -1 dBm optical Rx power, the 0 dB setting is used for -6 to -4 dBm Rx power.
3. For forward receiver module only. Does not include frequency response contributions from forward optical transmitter.
4. Minimum receiver RF output level for the stated transmitter percent OMI/ch. (Optical Modulation Index per channel), with receiver optical input power of 0 dBm (Standard Rx), with receiver optical input power of -4 dBm (Low Input Rx) and specified Rx attenuator setting. To determine RF output levels at other optical input power, add (or subtract) 2 dB in RF level for each 1 dB increase (or decrease) in receiver optical input power.

For reverse optical transmitter and link performance, see the “Analog Reverse Optical Transmitters with Thermal Compensation” data sheet.

Unless otherwise noted, specifications reflect typical performance and are referenced to 68° F (20° C). Specifications are based upon measurements made in accordance with SCTE and ANSI standards (where applicable), using standard frequency assignments.

RF Section Specifications

Tables 2, 3, and 4 list RF section specifications.

Table 2. RF Section General Station Performance

General Station Performance	Units	Forward	Reverse	Notes
Pass Band	MHz	54-1002	5-42	
Input/Output Port Return Loss	dB	17	16	
Hum Modulation at 12 A	dB	70 (54-870 MHz) 60 (871-1002 MHz)	60 (5-10 MHz) 70 (11-42 MHz)	
Hum Modulation at 15 A	dB	65 (54-870 MHz) 60 (871-1002 MHz)	60 (5-10 MHz) 65 (11-42 MHz)	
Test Points (± 0.5 dB)	dB	-20	-20	

Table 3. RF Section Forward Station Performance

Forward Station Performance	Units	15 dB I/S EQ with 0.5 dB I/S Pad	Notes
Amplifier type	-	GaN	
Operational gain (minimum)	dB	34	1
Frequency response	dB	± 0.5	1
Internal tilt (± 1 dB)	dB	14.5	1, 2
Port to port isolation with full segmentation	dB	60 (54-750 MHz) 55 (751-1002 MHz)	1
Port to port isolation with left/right segmentation	dB	66 (54-750 MHz) 55 (751-1002 MHz)	1
Noise figure at:			
54 MHz	dB	14.0	1
1002 MHz		13.5	
Reference output levels at:	dBmV		3
1002 MHz		60	
870 MHz		58	
750 MHz		56.2	
650 MHz		54.5	
550 MHz		53	
55 MHz		45.5	
Reference output tilt (54 - 1002 MHz)	dB	14.5	2, 4
73 NTSC channels (CW) with digital			7
Composite triple beat	dB	60	5
Composite second order (high side)	dB	62	5
Cross modulation	dB	52	5, 8
Composite intermodulation noise (CIN)	dB	51	5

Table 4. RF Section Reverse Station Performance

Reverse Station Performance	Units	Reverse	Notes
Amplifier type	-	GaAs FET	
Operational gain (minimum)	dB	-2	6
Frequency response	dB	± 0.5	6
Internal tilt (+/- 1 dB)	dB	0	6
Path to path isolation	dB	55	6
Noise figure	dB	7.5	6

Notes for Tables 3 and 4:

1. Forward performance is for station from output of optical Rx to node RF output port, with 0 dB pad in optical interface board (OIB), any forward configuration module, 0 dB interstage (I/S) pad, 15 dB linear I/S EQ, factory select output pad, and signal director jumper. Includes OIB losses.
2. Reference output tilt and internal tilt are both "linear" tilt.
3. RF Output Levels are referenced to an Optical Input Level at -1 dBm for 1550 nm at 3.0% OMI or 1310 nm at 3.5% OMI.
4. The forward reference output tilt specified is achieved via field installation of appropriate linear I/S EQ, in conjunction with the internal tilt of the launch amplifier and the tilt associated with the optical link (transmitter/receiver combination).
5. Stated distortion performance is for launch amplifier section operated at reference output levels and tilts. Full station performance can be determined by combining optic performance and launch amplifier performance.
6. Reverse performance is for station from reverse input port to input of reverse optical transmitter module, with 0 dB reverse input pad.
7. Loaded with 78 NTSC CW carriers from 55-550 MHz. "Digital" refers to 550 - 1002 MHz loading with QAM carriers at -6 dB relative to analog video carrier levels.
8. X-mod (at 15.75 kHz) specified using 100% synchronous modulation and frequency-selective measurement device.

Other Specifications

Table 5. Station Delay Characteristics

Station Delay Characteristics 42/54 MHz Split			
Forward (Chrominance to Luminance Delay)		Reverse (Group Delay in 1.5 MHz BW)	
Frequency (MHz)	Delay (nS)	Frequency (MHz)	Delay (nS)
55.25 - 58.83	18	5.0 - 6.5	35
61.25 - 64.83	8	6.5 - 8.0	15
67.25 - 70.83	5	8.0 - 9.5	7
		37.5 - 39.0	11
		39.0 - 40.5	14
		40.5 - 42.0	20

Table 6. Electrical Power Specifications

Electrical	Units				
Max. AC Through Current (continuous)	A	15			
Max. AC Through Current (surge)	A	25			
Component DC Power Consumption (typical)		@+24 VDC	@ +8 VDC	@ +5 VDC	@ -6 VDC
Launch Amplifier (includes reverse amp)	A	2.8	0.4	0.5	-
Status Monitoring Transponder	A	0.01	-	0.2	-
GS7000 Low Current Optical Receiver	A	0.12	-	-	-
Reverse Transmitter: High Gain FP	A	0.09	-	-	0.07
Reverse Transmitter: High Gain DFB	A	0.09	-	-	0.09
Power Supply DC Current Rating	A	6.20	0.90	1.30	0.80

Table 7. Station Powering Data

Station Powering Data												
GS7000 Node	I DC (A at 24 VDC)		AC Voltage									
			90	85	80	75	70	65	60	55	50	45
With: 1 forward Rx, 1x4 forward config module, 1 reverse Tx, 4x1 reverse configuration module	2.95	AC Current (A)	1.4	1.4	1.4	1.5	1.5	1.6	1.7	1.8	2.0	2.2
		Power (W)	96.4	96.2	95.9	95.6	95.4	95.4	95.3	95.3	95.5	95.8
With: 4 forward Rx's, 4x4 forward config module, 4 reverse Txs, 4x4 reverse configuration module	3.70	AC Current (A)	1.7	1.7	1.7	1.8	1.9	2.0	2.1	2.3	2.5	2.8
		Power (W)	121.5	121.1	120.8	120.6	120.6	120.5	120.5	120.7	120.9	121.0

Data in Table 7 is based on stations configured with a status monitoring transponder. AC currents specified are based on measurements made with typical CATV type ferroresonant AC power supply (quasi-square wave). DC supply has a fixed under-voltage lockout of 33 VAC.

Table 8. Environmental and Mechanical Specifications

Environmental	
Operating temperature range	-40 - 140°F (-40 - 60°C)
Relative humidity range	5% to 95%
Mechanical	
Housing Dimensions	21.3 in. L x 11.6 in. H x 11.1 in. D (541 mm x 295 mm x 282 mm)
Weight	Station with 4 RX, 4 TX, 2 power supplies: 50.0 lbs. (22.7 kg)

Ordering Information

The Cisco GS7000 Node is available in a wide variety of configurations. The GS7000 Ordering Matrix provides ordering information for configured node stations.

Table 9 contains ordering information for required and optional accessories. Please consult with your Account Representative, Customer Service Representative, or Applications Engineer to determine the best configuration for your particular application.

Table 9. Cisco GS7000 Node Accessories

Required Accessories	Part Number
Plug-in Pads (attenuators): Available in 0.5 dB steps from 0 to 20 dB <ul style="list-style-type: none"> • 1 required for each Optical Receiver Module installed in the node (for Optical Interface Board) • 1 required for each Optical Transmitter Module installed in the node (for Optical Interface Board) • 1 required for each Reverse input path activated (for Launch Amplifier) 	589693 (0 dB) sequentially thru 589734 (20.5dB)
Optional Accessories	
Plug-in Forward Linear Equalizers: Available in 1.5 dB steps from 0 to 21 dB. <ul style="list-style-type: none"> • Node shipped with 15 dB Linear Equalizers (4) installed for 14.5 dB of tilt to 1002 MHz (4008787) 	4007228 (0 dB) see table below
Plug-in Signal Directors - 2 required Node shipped with Jumpers installed to activate 4 RF output ports <ul style="list-style-type: none"> • Optional 2-Way Splitters are required to activate 5 or 6 RF output ports 	4011907 4011908

Note: Configured nodes ship without reverse input pads and any of the pads on the OIB. All other standard accessories are shipped from the factory. Forward Launch Amplifier attenuator pads, (4) 15 dB linear EQs, and (2) signal director jumpers are shipped with every configured node.

Table 10. Cisco GS7000 Forward Components

GS7000 Forward Launch Amplifiers	Part Number on Module	Part Number for Ordering
Node High Output Launch Amplifier, 4-way forward segmentation, 42/54 MHz split	GS7K-LA-HO-4254	GS7K-LA-HO-4254=
GS7000 Forward Configuration Modules		
Forward Configuration Module, 1x4	4019273	4019283
Forward Configuration Module, 1x4 Redundant	4019275	4019284
Forward Configuration Module, 1x4, Forward RF Injection, Redundant	4022272	4022270
Forward Configuration Module, 2x4	4019277	4019285
Forward Configuration Module, 2x4 Redundant	4019279	4019286
Forward Configuration Module, 3x4, RX 1, 3, 4	4024784	4024783
Forward Configuration Module, 3x4, RX 1, 2, 4	4024786	4024785
Forward Configuration Module, 4x4	4019281	4019287
Forward Linear Equalizers		
0 dB 1GHz Forward Linear EQ	-	4007228
1.5 dB 1GHz Forward Linear EQ	-	4008778
3.0 dB 1GHz Forward Linear EQ	-	4008779
4.5 dB 1GHz Forward Linear EQ	-	4008780
6.0 dB 1GHz Forward Linear EQ	-	4008781
7.5 dB 1GHz Forward Linear EQ	-	4008782
9.0 dB 1GHz Forward Linear EQ	-	4008783

GS7000 Forward Launch Amplifiers	Part Number on Module	Part Number for Ordering
10.5 dB 1GHz Forward Linear EQ	-	4008784
12.0 dB 1GHz Forward Linear EQ	-	4008785
13.5 dB 1GHz Forward Linear EQ	-	4008786
15.0 dB 1GHz Forward Linear EQ	-	4008787
16.5 dB 1GHz Forward Linear EQ	-	4019258
18.0 dB 1GHz Forward Linear EQ	-	4019259
19.5 dB 1GHz Forward Linear EQ	-	4019260
21.0 dB 1GHz Forward Linear EQ	-	4019261
GS7000 Node Signal Directors		
Node Signal Director Jumper	4009369	4011907
Node Signal Director Splitter	4009371	4011908
GS7000 Optical Receivers		
Standard Optical Receiver, SCA connector	4022468	4013593
Standard Optical Receiver, SCU connector	4022469	4013594
Standard Optical Receiver, FCA connector	4022470	4013595
Low Input Optical Receiver, SCA connector	GS7K-LIRX-SA	GS7K-LIRX-SA=
Low Input Optical Receiver, FCA connector	GS7K-LIRX-FC	GS7K-LIRX-FC=
GS7000 Forward Local Injection Module Kit (does not include FCM)		
Forward Local Injection Module	-	4013575

Table 11. Cisco GS7000 Reverse Amplifiers and Configuration Modules

GS7000 Reverse Configuration Modules	Part Number on Module	Part Number for Ordering
Reverse Configuration Module, 4x1, Aux Reverse RF Injection	4014282	4011918
Reverse Configuration Module, 4x1, Redundant	4009066	4011919
Reverse Configuration Module, 4x2, Aux Reverse RF Injection (for use with 8-position OIB)	4014286	4014300
Reverse Configuration Module, 4x2, Redundant	4009076	4011921
Reverse Configuration Module, 4x3, TX 1, 3, 4	4024788	4024787
Reverse Configuration Module, 4x3, TX 1, 2, 4	4024791	4024790
Reverse Configuration Module, 4x4, Aux Reverse RF Injection	4014289	4011922
GS7000 1310 nm Reverse Optical Transmitters		
3 dBm, DFB, High Gain, Analog, SC/APC	4013900.1310	4011952
3 dBm, DFB, High Gain, Analog, SC/UPC	4013901.1310	4011953
3 dBm, DFB, High Gain, Analog, FC/APC	4013902.1310	4011954

Table 12. Cisco GS700 CWDM Reverse Optical Transmitters

GS7000 CWDM Reverse Optical Transmitters	Part Number on Module	Part Number for Ordering
3 dBm, CWDM High Gain, 1470 nm, Analog, SC/APC	4013900.1470	4011955
3 dBm, CWDM High Gain, 1490 nm, Analog, SC/APC	4013900.1490	4011956
3 dBm, CWDM High Gain, 1510 nm, Analog, SC/APC	4013900.1510	4011957
3 dBm, CWDM High Gain, 1530 nm, Analog, SC/APC	4013900.1530	4011961
3 dBm, CWDM High Gain, 1550 nm, Analog, SC/APC	4013900.1550	4011965
3 dBm, CWDM High Gain, 1570 nm, Analog, SC/APC	4013900.1570	4011966
3 dBm, CWDM High Gain, 1590 nm, Analog, SC/APC	4013900.1590	4011967

GS7000 CWDM Reverse Optical Transmitters	Part Number on Module	Part Number for Ordering
3 dBm, CWDM High Gain, 1610 nm, Analog, SC/APC	4013900.1610	4011968
3 dBm, CWDM High Gain, 1470 nm, Analog, SC/UPC	4013901.1470	4011969
3 dBm, CWDM High Gain, 1490 nm, Analog, SC/UPC	4013901.1490	4011970
3 dBm, CWDM High Gain, 1510 nm, Analog, SC/UPC	4013901.1510	4011974
3 dBm, CWDM High Gain, 1530 nm, Analog, SC/UPC	4013901.1530	4011975
3 dBm, CWDM High Gain, 1550 nm, Analog, SC/UPC	4013901.1550	4011976
3 dBm, CWDM High Gain, 1570 nm, Analog, SC/UPC	4013901.1570	4011977
3 dBm, CWDM High Gain, 1590 nm, Analog, SC/UPC	4013901.1590	4013218
3 dBm, CWDM High Gain, 1610 nm, Analog, SC/UPC	4013901.1610	4013299
3 dBm, CWDM High Gain, 1470 nm, Analog, FC/APC	4013902.1470	4013542
3 dBm, CWDM High Gain, 1490 nm, Analog, FC/APC	4013902.1490	4013543
3 dBm, CWDM High Gain, 1510 nm, Analog, FC/APC	4013902.1510	4013544
3 dBm, CWDM High Gain, 1530 nm, Analog, FC/APC	4013902.1530	4013545
3 dBm, CWDM High Gain, 1550 nm, Analog, FC/APC	4013902.1550	4013546
3 dBm, CWDM High Gain, 1570 nm, Analog, FC/APC	4013902.1570	4013547
3 dBm, CWDM High Gain, 1590 nm, Analog, FC/APC	4013902.1590	4013548
3 dBm, CWDM High Gain, 1610 nm, Analog, FC/APC	4013902.1610	4013549

Table 13. Cisco GS7000 DWDM Reverse Optical Transmitters

GS7000 DWDM Reverse Optical Transmitters	Part Number on Module	Part Number for Ordering
7 dBm, DWDM, ITU Grid, CH. 19, 1562.23 nm, Analog, SC/APC	4022938.19	4022938.19
7 dBm, DWDM, ITU Grid, CH. 20, 1561.42 nm, Analog, SC/APC	4022938.20	4022938.20
7 dBm, DWDM, ITU Grid, CH. 21, 1560.61 nm, Analog, SC/APC	4022938.21	4022938.21
7 dBm, DWDM, ITU Grid, CH. 22, 1559.79 nm, Analog, SC/APC	4022938.22	4022938.22
7 dBm, DWDM, ITU Grid, CH. 23, 1558.98 nm, Analog, SC/APC	4022938.23	4022938.23
7 dBm, DWDM, ITU Grid, CH. 24, 1558.17 nm, Analog, SC/APC	4022938.24	4022938.24
7 dBm, DWDM, ITU Grid, CH. 25, 1557.36 nm, Analog, SC/APC	4022938.25	4022938.25
7 dBm, DWDM, ITU Grid, CH. 26, 1556.55 nm, Analog, SC/APC	4022938.26	4022938.26
7 dBm, DWDM, ITU Grid, CH. 27, 1555.75 nm, Analog, SC/APC	4022938.27	4022938.27
7 dBm, DWDM, ITU Grid, CH. 28, 1554.94 nm, Analog, SC/APC	4022938.28	4022938.28
7 dBm, DWDM, ITU Grid, CH. 29, 1554.13 nm, Analog, SC/APC	4022938.29	4022938.29
7 dBm, DWDM, ITU Grid, CH. 30, 1553.33 nm, Analog, SC/APC	4022938.30	4022938.30
7 dBm, DWDM, ITU Grid, CH. 31, 1552.52 nm, Analog, SC/APC	4022938.31	4022938.31
7 dBm, DWDM, ITU Grid, CH. 32, 1551.72 nm, Analog, SC/APC	4022938.32	4022938.32
7 dBm, DWDM, ITU Grid, CH. 33, 1550.92 nm, Analog, SC/APC	4022938.33	4022938.33
7 dBm, DWDM, ITU Grid, CH. 34, 1550.12 nm, Analog, SC/APC	4022938.34	4022938.34
7 dBm, DWDM, ITU Grid, CH. 35, 1549.32 nm, Analog, SC/APC	4022938.35	4022938.35
7 dBm, DWDM, ITU Grid, CH. 36, 1548.51 nm, Analog, SC/APC	4022938.36	4022938.36
7 dBm, DWDM, ITU Grid, CH. 37, 1547.72 nm, Analog, SC/APC	4022938.37	4022938.37
7 dBm, DWDM, ITU Grid, CH. 38, 1546.92 nm, Analog, SC/APC	4022938.38	4022938.38
7 dBm, DWDM, ITU Grid, CH. 39, 1546.12 nm, Analog, SC/APC	4022938.39	4022938.39
7 dBm, DWDM, ITU Grid, CH. 40, 1545.32 nm, Analog, SC/APC	4022938.40	4022938.40
7 dBm, DWDM, ITU Grid, CH. 41, 1544.53 nm, Analog, SC/APC	4022938.41	4022938.41
7 dBm, DWDM, ITU Grid, CH. 42, 1543.73 nm, Analog, SC/APC	4022938.42	4022938.42

GS7000 DWDM Reverse Optical Transmitters	Part Number on Module	Part Number for Ordering
7 dBm, DWDM, ITU Grid, CH. 43, 1542.94 nm, Analog, SC/APC	4022938.43	4022938.43
7 dBm, DWDM, ITU Grid, CH. 44, 1542.14 nm, Analog, SC/APC	4022938.44	4022938.44
7 dBm, DWDM, ITU Grid, CH. 45, 1541.35 nm, Analog, SC/APC	4022938.45	4022938.45
7 dBm, DWDM, ITU Grid, CH. 46, 1540.56 nm, Analog, SC/APC	4022938.46	4022938.46
7 dBm, DWDM, ITU Grid, CH. 47, 1539.77 nm, Analog, SC/APC	4022938.47	4022938.47
7 dBm, DWDM, ITU Grid, CH. 48, 1538.98 nm, Analog, SC/APC	4022938.48	4022938.48
7 dBm, DWDM, ITU Grid, CH. 49, 1538.19 nm, Analog, SC/APC	4022938.49	4022938.49
7 dBm, DWDM, ITU Grid, CH. 50, 1537.40 nm, Analog, SC/APC	4022938.50	4022938.50
7 dBm, DWDM, ITU Grid, CH. 51, 1536.61 nm, Analog, SC/APC	4022938.51	4022938.51
7 dBm, DWDM, ITU Grid, CH. 52, 1535.82 nm, Analog, SC/APC	4022938.52	4022938.52
7 dBm, DWDM, ITU Grid, CH. 53, 1535.04 nm, Analog, SC/APC	4022938.53	4022938.53
7 dBm, DWDM, ITU Grid, CH. 54, 1534.25 nm, Analog, SC/APC	4022938.54	4022938.54
7 dBm, DWDM, ITU Grid, CH. 55, 1533.47 nm, Analog, SC/APC	4022938.55	4022938.55
7 dBm, DWDM, ITU Grid, CH. 56, 1532.68 nm, Analog, SC/APC	4022938.56	4022938.56
7 dBm, DWDM, ITU Grid, CH. 57, 1531.90 nm, Analog, SC/APC	4022938.57	4022938.57
7 dBm, DWDM, ITU Grid, CH. 58, 1531.12 nm, Analog, SC/APC	4022938.58	4022938.58
7 dBm, DWDM, ITU Grid, CH. 59, 1530.33 nm, Analog, SC/APC	4022938.59	4022938.59

Table 14. Cisco GS7000 EDR CWDM Reverse Optical Transmitters

GS7000 EDR CWDM Reverse Optical Transmitters	Part Number on Tx Module	Part Number of OPM	Part Number for Ordering
EDR GS2185 Tx with OPM CWDM-1270	4042904	4043989.1270	4042879.1270
EDR GS2185 Tx with OPM CWDM-1290	4042904	4043989.1290	4042879.1290
EDR GS2185 Tx with OPM CWDM-1310	4042904	4043989.1310	4042879.1310
EDR GS2185 Tx with OPM CWDM-1330	4042904	4043989.1330	4042879.1330
EDR GS2185 Tx with OPM CWDM-1350	4042904	4043989.1350	4042879.1350
EDR GS2185 Tx with OPM CWDM-1370	4042904	4043989.1370	4042879.1370
EDR GS2185 Tx with OPM CWDM-1390	4042904	4043989.1390	4042879.1390
EDR GS2185 Tx with OPM CWDM-1410	4042904	4043989.1410	4042879.1410
EDR GS2185 Tx with OPM CWDM-1430	4042904	4043989.1430	4042879.1430
EDR GS2185 Tx with OPM CWDM-1450	4042904	4043989.1450	4042879.1450
EDR GS2185 Tx with OPM CWDM-1470	4042904	4043989.1470	4042879.1470
EDR GS2185 Tx with OPM CWDM-1490	4042904	4043989.1490	4042879.1490
EDR GS2185 Tx with OPM CWDM-1510	4042904	4043989.1510	4042879.1510
EDR GS2185 Tx with OPM CWDM-1530	4042904	4043989.1530	4042879.1530
EDR GS2185 Tx with OPM CWDM-1550	4042904	4043989.1550	4042879.1550
EDR GS2185 Tx with OPM CWDM-1570	4042904	4043989.1570	4042879.1570
EDR GS2185 Tx with OPM CWDM-1590	4042904	4043989.1590	4042879.1590
EDR GS2185 Tx with OPM CWDM-1610	4042904	4043989.1610	4042879.1610

Table 15. Cisco GS7000 EDR DWDM Reverse Optical Transmitters

GS7000 EDR DWDM Reverse Optical Transmitters	Part Number on Tx Module	Part Number of OPM	Part Number for Ordering
EDR GS2185 Tx with OPM DWDM-17	4042904	4043988.17	4042880.17
EDR GS2185 Tx with OPM DWDM-18	4042904	4043988.18	4042880.18
EDR GS2185 Tx with OPM DWDM-19	4042904	4043988.19	4042880.19
EDR GS2185 Tx with OPM DWDM-20	4042904	4043988.20	4042880.20
EDR GS2185 Tx with OPM DWDM-21	4042904	4043988.21	4042880.21
EDR GS2185 Tx with OPM DWDM-22	4042904	4043988.22	4042880.22
EDR GS2185 Tx with OPM DWDM-23	4042904	4043988.23	4042880.23
EDR GS2185 Tx with OPM DWDM-24	4042904	4043988.24	4042880.24
EDR GS2185 Tx with OPM DWDM-25	4042904	4043988.25	4042880.25
EDR GS2185 Tx with OPM DWDM-26	4042904	4043988.26	4042880.26
EDR GS2185 Tx with OPM DWDM-27	4042904	4043988.27	4042880.27
EDR GS2185 Tx with OPM DWDM-28	4042904	4043988.28	4042880.28
EDR GS2185 Tx with OPM DWDM-29	4042904	4043988.29	4042880.29
EDR GS2185 Tx with OPM DWDM-30	4042904	4043988.30	4042880.30
EDR GS2185 Tx with OPM DWDM-31	4042904	4043988.31	4042880.31
EDR GS2185 Tx with OPM DWDM-32	4042904	4043988.32	4042880.32
EDR GS2185 Tx with OPM DWDM-33	4042904	4043988.33	4042880.33
EDR GS2185 Tx with OPM DWDM-34	4042904	4043988.34	4042880.34
EDR GS2185 Tx with OPM DWDM-35	4042904	4043988.35	4042880.35
EDR GS2185 Tx with OPM DWDM-36	4042904	4043988.36	4042880.36
EDR GS2185 Tx with OPM DWDM-37	4042904	4043988.37	4042880.37
EDR GS2185 Tx with OPM DWDM-38	4042904	4043988.38	4042880.38
EDR GS2185 Tx with OPM DWDM-39	4042904	4043988.39	4042880.39
EDR GS2185 Tx with OPM DWDM-40	4042904	4043988.40	4042880.40
EDR GS2185 Tx with OPM DWDM-41	4042904	4043988.41	4042880.41
EDR GS2185 Tx with OPM DWDM-42	4042904	4043988.42	4042880.42
EDR GS2185 Tx with OPM DWDM-43	4042904	4043988.43	4042880.43
EDR GS2185 Tx with OPM DWDM-44	4042904	4043988.44	4042880.44
EDR GS2185 Tx with OPM DWDM-45	4042904	4043988.45	4042880.45
EDR GS2185 Tx with OPM DWDM-46	4042904	4043988.46	4042880.46
EDR GS2185 Tx with OPM DWDM-47	4042904	4043988.47	4042880.47
EDR GS2185 Tx with OPM DWDM-48	4042904	4043988.48	4042880.48
EDR GS2185 Tx with OPM DWDM-49	4042904	4043988.49	4042880.49
EDR GS2185 Tx with OPM DWDM-50	4042904	4043988.50	4042880.50
EDR GS2185 Tx with OPM DWDM-51	4042904	4043988.51	4042880.51
EDR GS2185 Tx with OPM DWDM-52	4042904	4043988.52	4042880.52
EDR GS2185 Tx with OPM DWDM-53	4042904	4043988.53	4042880.53
EDR GS2185 Tx with OPM DWDM-54	4042904	4043988.54	4042880.54
EDR GS2185 Tx with OPM DWDM-55	4042904	4043988.55	4042880.55
EDR GS2185 Tx with OPM DWDM-56	4042904	4043988.56	4042880.56
EDR GS2185 Tx with OPM DWDM-57	4042904	4043988.57	4042880.57

GS7000 EDR DWDM Reverse Optical Transmitters	Part Number on Tx Module	Part Number of OPM	Part Number for Ordering
EDR GS2185 Tx with OPM DWDM-58	4042904	4043988.58	4042880.58
EDR GS2185 Tx with OPM DWDM-59	4042904	4043988.59	4042880.59
EDR GS2185 Tx with OPM DWDM-60	4042904	4043988.60	4042880.60
EDR GS2185 Tx with OPM DWDM-61	4042904	4043988.61	4042880.61

Table 16. Cisco GS7000 Additional Components

Cisco GS7000 Additional Components	Part Number on Module	Part Number for Ordering
Optical Interface Board		
8-position Optical Interface Board, 4Rx/4Tx	4023056	4011927
Power Supply		
Node Power Supply	4009226	4011930
Local Control Modules and Status Monitoring Modules (with USB interface)		
Local Control Module (LCM)	4027113	4027114
EDR Local Control Module (EDR/LCM)	-	4044102
Status Monitoring Module: DOCSIS	-	4036793
Test Point Cable Kit		
Test Point Cable Kit, (includes the 6 cables required to enable GS7000 housing external test points)	4016084	4013568
Optical Fiber Tray Kit		
Standard Fiber Tray	-	4042908
Expanded Fiber Tray (additional fiber handling/routing capacity), without brackets, SCA	-	4057377
Expanded Fiber Tray (additional fiber handling/routing capacity), with brackets, SCA	-	4026885
Expanded Fiber Tray (additional fiber handling/routing capacity), with brackets, SCU	-	4028274
Expanded Fiber Tray Brackets Only	-	4027000
Housings		
GS7000 Node Housing, empty	-	4009045
GS7000 Node Housing, Expanded Tray, SCA	-	4027378
GS7000 Node Housing, Expanded Tray, SCU	-	4028275
GS7000 Node Housing, Standard Tray	-	4012095
Optical Fiber Tray Kit		
Standard Fiber Tray	-	4027376
Expanded Fiber Tray (additional fiber handling and routing capacity): includes brackets for passives and 4 SC APC bulkheads	-	4026885
Expanded Fiber Tray (additional fiber handling and routing capacity): includes brackets for passives and 4 SC UPC bulkheads	-	4028274
Brackets for passives used in Expanded Fiber Tray	-	4027000
SC APC bulkheads, package of 10	-	4027740
SC UPC bulkheads, package of 10	-	4027741

Cisco GS7000 Additional Components	Part Number on Module	Part Number for Ordering
Optical Amplifiers and Switch		
17 dBm Broadcast Amplifier	-	4027007
20 dBm Broadcast Amplifier	-	4027008
22 dBm Broadcast Amplifier	-	4027009
17 dBm Narrowcast Gain Flattened Amplifier (40 Wavelength) - Low Gain	-	GS7K-GFEDFA-17L=
17 dBm Narrowcast Gain Flattened Amplifier (40 Wavelength) - High Gain	-	GS7K-GFEDFA-17H=
21 dBm Narrowcast Gain Flattened Amplifier (40 Wavelength) - Low Gain	-	GS7K-GFEDFA-21L=
21 dBm Narrowcast Gain Flattened Amplifier (40 Wavelength) - High Gain	-	GS7K-GFEDFA-21H=
Optical Switch	-	4027014
GS7000 Frequency Split Kit		
GS7000 Frequency Split Kit 85/105 (PKG OF 10)		GS7K-SPLTKT-85105=
GS7000 Split Kit Cable Assembly		GS7K-SPLKT-CBL

Cisco Systems, Inc.
1 800 722-2009 or 678 277-1120
<http://www.cisco.com>



Americas Headquarters
Cisco Systems, Inc.
San Jose, CA

Asia Pacific Headquarters
Cisco Systems (USA) Pte. Ltd.
Singapore

Europe Headquarters
Cisco Systems International BV Amsterdam,
The Netherlands

Cisco has more than 200 offices worldwide. Addresses, phone numbers, and fax numbers are listed on the Cisco Website at www.cisco.com/go/offices.

Cisco and the Cisco logo are trademarks or registered trademarks of Cisco and/or its affiliates in the U.S. and other countries. To view a list of Cisco trademarks, go to this URL: www.cisco.com/go/trademarks. Third party trademarks mentioned are the property of their respective owners. The use of the word partner does not imply a partnership relationship between Cisco and any other company. (1110R)