



# Compact EGC Amplifier 93250 Installation and Setup Instructions

## Application

The Compact Amplifier type 93250 has one active output and is used in trunk and distribution applications. The amplifier can be monitored via the compact transponder and the ROSA™ Element Management System. All equalizers and pads are electronic and can be set with the handheld terminal type 91200. The plug-in filters in the reverse path allow flexible choice of frequency range for both forward and reverse path.

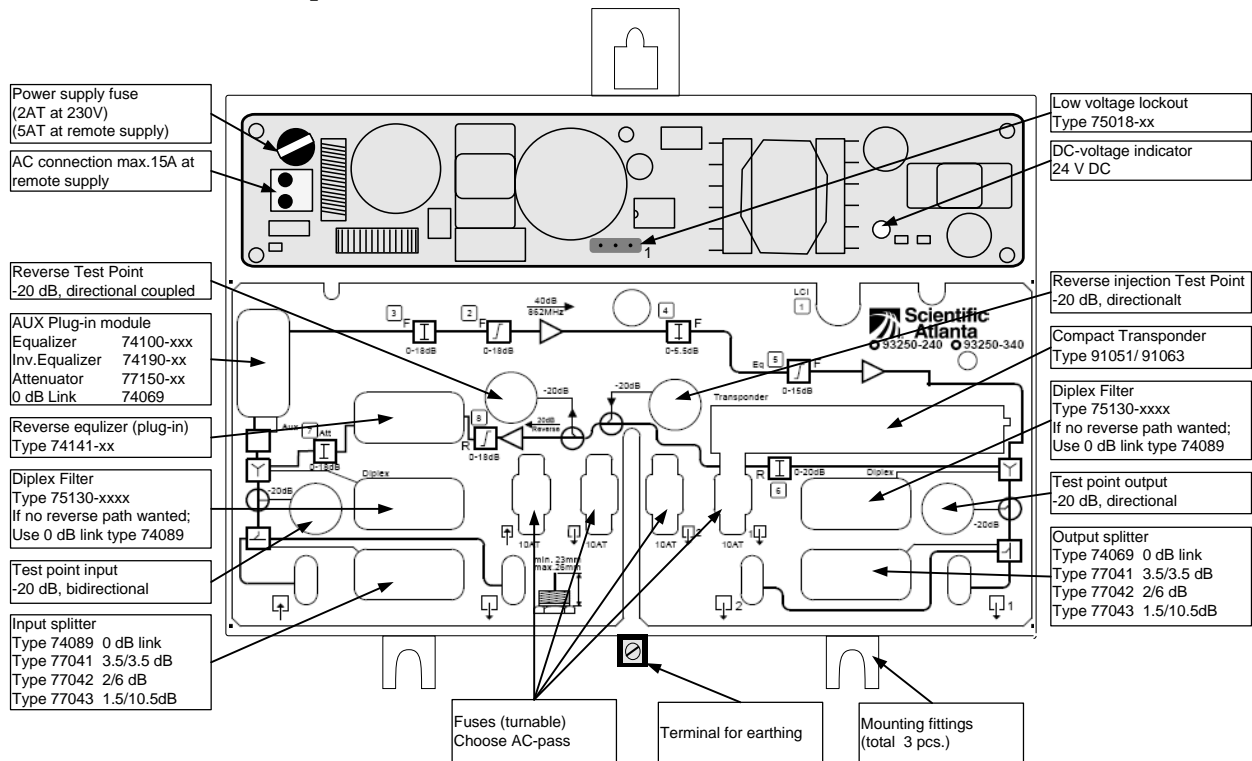

Figure 1: Amplifier overview

# Important Safety Instructions

---

## Read and Retain Instructions

Carefully read all safety and operating instructions before operating this equipment, and retain them for future reference.

## Follow Instructions and Heed Warnings

Follow all operating and use instructions. Pay attention to all warnings and cautions in the operating instructions, as well as those that are affixed to this equipment.

## Terminology

The terms defined below are used in this document. The definitions given are based on those found in safety standards.

**Service Personnel** - The term *service personnel* applies to trained and qualified individuals who are allowed to install, replace, or service electrical equipment. The service personnel are expected to use their experience and technical skills to avoid possible injury to themselves and others due to hazards that exist in service and restricted access areas.

**User and Operator** - The terms *user* and *operator* apply to persons other than service personnel.

**Ground(ing) and Earth(ing)** - The terms *ground(ing)* and *earth(ing)* are synonymous. This document uses *ground(ing)* for clarity, but it can be interpreted as having the same meaning as *earth(ing)*.

## Electric Shock Hazard

This equipment meets applicable safety standards.



**WARNING:**

**To reduce risk of electric shock, perform only the instructions that are included in the operating instructions. Refer all servicing to qualified service personnel only.**

Electric shock can cause personal injury or even death. Avoid direct contact with dangerous voltages at all times.

Know the following safety warnings and guidelines:

- Only qualified service personnel are allowed to perform equipment installation or replacement.
- Only qualified service personnel are allowed to remove chassis covers and access any of the components inside the chassis.

---

*Continued on next page*

## Important Safety Instructions, Continued

---

### Equipment Placement



**WARNING:**

**Avoid personal injury and damage to this equipment. An unstable mounting surface may cause this equipment to fall.**

To protect against equipment damage or injury to personnel, comply with the following:

- Install this equipment in a restricted access location (access restricted to service personnel).
- Make sure the mounting surface or rack is stable and can support the size and weight of this equipment.

### Pedestal, Service Closet, Equipment Room or Underground Vault Installation



**WARNING:**

**Avoid the possibility of personal injury. Ensure proper handling/lifting techniques are employed when working in confined spaces with heavy equipment.**

- Ensure this equipment is securely fastened to the mounting surface or rack where necessary to protect against damage due to any disturbance and subsequent fall.
- Ensure the mounting surface or rack is appropriately anchored according to manufacturer's specifications.
- Ensure the installation site meets the ventilation requirements given in the equipment's data sheet to avoid the possibility of equipment overheating.
- Ensure the installation site and operating environment is compatible with the equipment's International Protection (IP) rating specified in the equipment's data sheet.

### Connection to Network Power Sources

Refer to this equipment's specific installation instructions in this manual or in companion manuals in this series for connection to network ferro-resonant AC power sources.

---

*Continued on next page*

## Important Safety Instructions, Continued

---

### AC Power Shunts

AC power shunts may be provided with this equipment.

**Important:** The power shunts (where provided) must be removed before installing modules into a powered housing. With the shunts removed, power surge to the components and RF-connectors is reduced.



**CAUTION:**

**RF connectors and housing seizure assemblies can be damaged if shunts are not removed from the equipment before installing or removing modules from the housing.**

### Equipotential Bonding

If this equipment is equipped with an external chassis terminal marked with the IEC 60417-5020 chassis icon () , the installer should refer to CENELEC standard EN 50083-1 or IEC standard IEC 60728-11 for correct equipotential bonding connection instructions.

### General Servicing Precautions



**WARNING:**

**Avoid electric shock! Opening or removing this equipment's cover may expose you to dangerous voltages.**



**CAUTION:**

**These servicing precautions are for the guidance of qualified service personnel only. To reduce the risk of electric shock, do not perform any servicing other than that contained in the operating instructions unless you are qualified to do so. Refer all servicing to qualified service personnel.**

Be aware of the following general precautions and guidelines:

- **Servicing** - Servicing is required when this equipment has been damaged in any way, such as power supply cord or plug is damaged, liquid has been spilled or objects have fallen into this equipment, this equipment has been exposed to rain or moisture, does not operate normally, or has been dropped.
- **Wristwatch and Jewelry** - For personal safety and to avoid damage of this equipment during service and repair, do not wear electrically conducting objects such as a wristwatch or jewelry.
- **Lightning** - Do not work on this equipment, or connect or disconnect cables, during periods of lightning.
- **Labels** - Do not remove any warning labels. Replace damaged or illegible warning labels with new ones.

---

*Continued on next page*

## Important Safety Instructions, Continued

---

- **Covers** - Do not open the cover of this equipment and attempt service unless instructed to do so in the instructions. Refer all servicing to qualified service personnel only.
- **Moisture** - Do not allow moisture to enter this equipment.
- **Cleaning** - Use a damp cloth for cleaning.
- **Safety Checks** - After service, assemble this equipment and perform safety checks to ensure it is safe to use before putting it back into operation.

### Electrostatic Discharge

Electrostatic discharge (ESD) results from the static electricity buildup on the human body and other objects. This static discharge can degrade components and cause failures.

Take the following precautions against electrostatic discharge:

- Use an anti-static bench mat and a wrist strap or ankle strap designed to safely ground ESD potentials through a resistive element.
- Keep components in their anti-static packaging until installed.
- Avoid touching electronic components when installing a module.

### Fuse Replacement

To replace a fuse, comply with the following:

- Disconnect the power before changing fuses.
- Identify and clear the condition that caused the original fuse failure.
- Always use a fuse of the correct type and rating. The correct type and rating are indicated on this equipment.

### Modifications

This equipment has been designed and tested to comply with applicable safety and EMC regulations, codes, and standards to ensure safe operation in its intended environment. Refer to this equipment's data sheet for details about regulatory compliance approvals.

Do not make modifications to this equipment. Any changes or modifications could void the user's authority to operate this equipment.

Modifications have the potential to degrade the level of protection built into this equipment, putting people and property at risk of injury or damage. Those persons making any modifications expose themselves to the penalties arising from proven non-compliance with regulatory requirements and to civil litigation for compensation in respect of consequential damages or injury.

---

*Continued on next page*

## Important Safety Instructions, Continued

---

### Accessories

Use only attachments or accessories specified by the manufacturer.

### Electromagnetic Compatibility Regulatory Requirements

This equipment meets applicable electromagnetic compatibility (EMC) regulatory requirements. Refer to this equipment's data sheet for details about regulatory compliance approvals. EMC performance is dependent upon the use of correctly shielded cables of good quality for all external connections, except the power source, when installing this equipment.

- Ensure compliance with cable/connector specifications and associated installation instructions where given elsewhere in this manual.
-

# Installation Instructions

---

## Mounting

The amplifier should be *mounted vertically* with the cable input underneath, to secure best possible operating temperature conditions. Use a 4 mm Allen key to tighten the screw in the lid to 5 Nm.

The pin length of the PG 11 cable connector at input and output is shown on the cover plate of the amplifier. If needed, trim the connector with wire cutters.

## Please Notice

This product can only be setup with a handheld terminal **type A91200.11** or with a handheld terminal **type A91200.10 containing the necessary driver for the EGC amplifier**. New drivers can be installed by means of download kit A91210.10.

## Plug-in Units

The following plug-in units are necessary.

- Input splitter. Link type 74089 is applied if the loop port is not used.
- Output splitter. If an asymmetric splitter (bridger) is used, the largest attenuation at the output 2 (OUT 2) is obtained. If only a signal at output 1 (OUT 1) is requested, link type 74069 is used.
- Diplex filter. Two diplex filters type 75130 with the required split frequency. Use two links type 74089 if the reverse path not is used.
- Plug-in reverse equalizer type 74141 with the required filter frequency. Determines the frequency range for the built-in active reverse path.
- AUX plug-in field. In order to adjust the amplifiers to the cable, it may be necessary to insert an equalizer type 74100-xxx at the input. Alternatively an inverse equalizer type 74190-xx or attenuator type 77150-xx can be used. If no equalization/attenuation is requested, insert 0 dB link type 74069.

---

*Continued on next page*

# Installation Instructions Installation Instructions, Continued

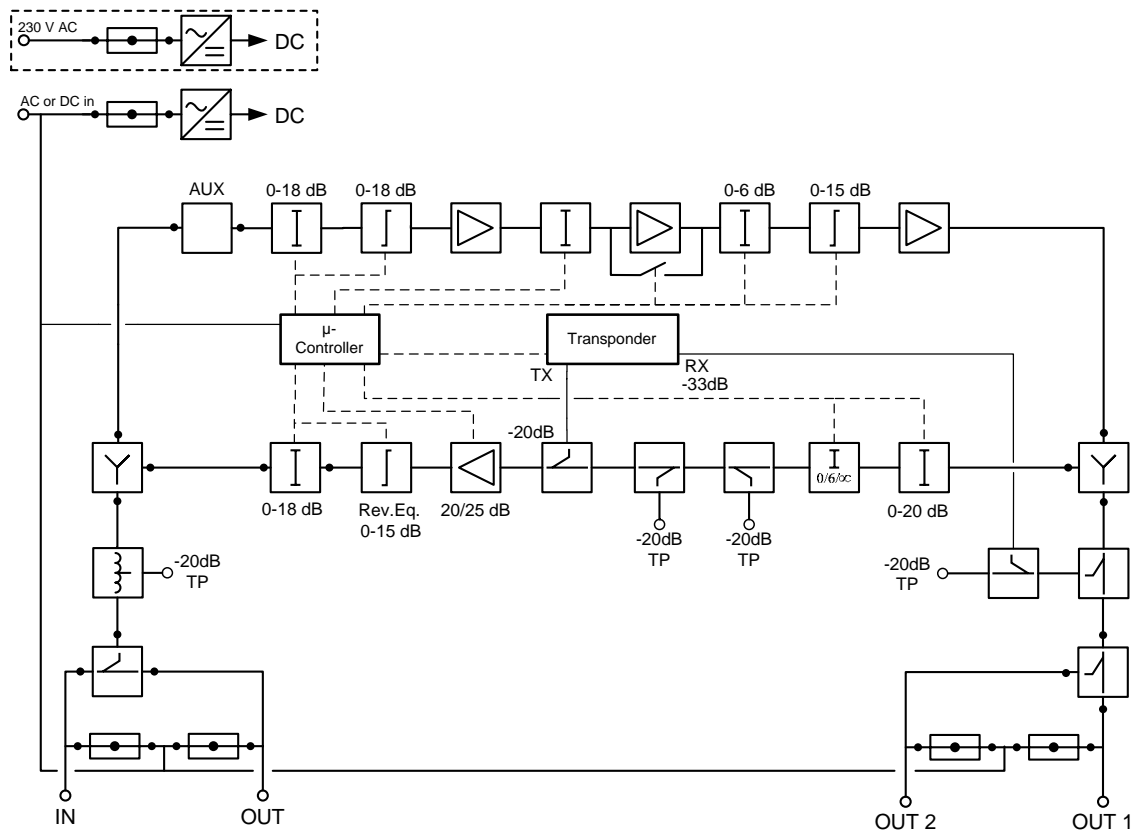

Figure 2: Block diagram for the amplifier type 93250

## Power Supply

### 230 V Mains Supply

The amplifier has factory mounted *mains cable and plugs*, which according to approval provisions may not be altered. The power unit is double insulated, and supplies only this single amplifier. When the power unit DC voltage indicator lights, the power unit is supplying correct DC voltage.

### Remote Supply 24 to 65 V AC

The amplifier can be supplied with 24 to 65 V AC either via coaxial cables (max. 8 A) or directly to the AC input (max. 15 A). In this case, the network AC supply apparatus shall be certified to provide basic insulation between the utility mains supply and the network AC supply voltage in accordance with an applicable safety standard such as IEC 60065, IEC 600950-1 or equivalent and local electrical regulations.

Continued on next page



## AC Pass

On delivery, ports are provided with insulating fuses. Desired AC pass is obtained by turning the fuse holder *after connecting* the cable or before disconnecting, to prevent damage of cable connectors.

### **Caution:**

**Permanent excess of maximum remote current may cause damage.**

## Low Voltage Lockout

For all coax line powered power supplies an undervoltage switch type 75018-xx can be delivered that switches off the power supply if the voltage drops below the rated value (24 V or 35 V) thus, the network is not damaged due to increased current consumption.

## Setting up the amplifier

The handheld terminal type 91200 is used to set up the amplifier. Use the menu structure in the following table to navigate through the different menus.

## Shortcuts

Use the short cuts shown on the cover plate to do a fast selection of the required menu.

For example: The output equalizer is marked with ⑤. By pressing the button "5" for approximately 1 sec. the terminal jumps to the menu where the output equalizer can be is changed.

The menu numbers can also be used as short cuts. Refer to the following menus structure (Fig. 3) to determine the number for the required menu.









For example: Press "35" and the handheld terminal will jump to the menu where the reverse switch can be set.

---

*Continued on next page*

# Installation Instructions Installation Instructions, Continued

Or use the following buttons:

 or  *	Is used to navigate to the submenus and to open a menu for editing. The value can then be changed. Additionally, the button can be used to reject a value entered by the keypad.
 or  *	Is used to navigate to the root menus and to delete wrong digits when a menu is open for editing. Additionally, the button can be used to reject a value entered by the keypad.
	All numbers, "." and "-" are used to enter values. The numbers can also be used as short cuts.
 	Is used to navigate through menus at the same level and to select the settings in some menus. Additionally, these buttons can be used to fine-tune some values.
 *	Is used to confirm a setting or a change.
In the menu "Copy Parameters," the setting of an amplifier can be saved (menu 51) and downloaded to another amplifier (menu 52).	

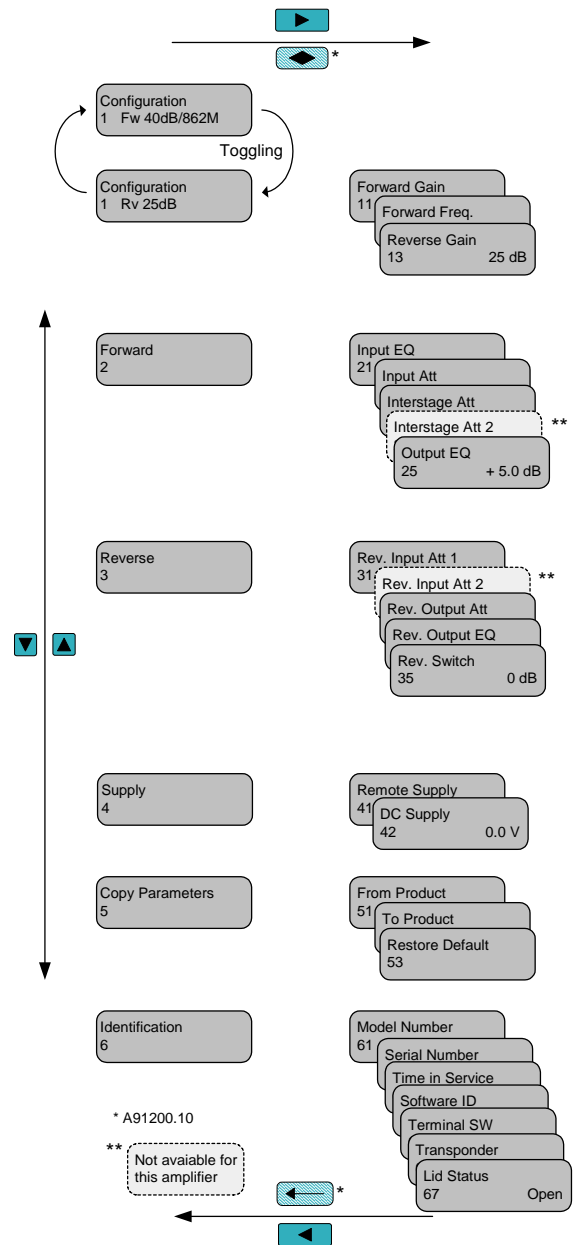

Figure 3. Menu Structure

Continued on next page

## Installation Instructions Installation Instructions, Continued

---

### ROSA Element Management System

Monitoring of the amplifier requires the installation of the transponder type 91051 in the amplifier. This transponder will communicate back to the headend by means of the reverse path. The transponder signal is received at the test point at output. Refer to Fig. 2. The level measured by the transponder will be attenuated by approximately 33 dB relative to the output signal at output. The transponder transmitter level is adjusted to the same level as the other reverse signals. The level from the transponder will be attenuated by approximately 20 dB at the reverse path since it is inserted with a 20 dB coupler.

With a transponder it is possible to monitor and control different parameters in the amplifier. As seen in Fig. 2, the built-in reverse path switch can be controlled in order to locate ingress noise in the reverse path. This can be useful in the search for errors in larger networks.

Programming of a Compact Transponder type 91051 is done by using the handheld terminal 91200.

The transponder can be set with:

SMC ID	Transponder address	1 to 65535
TX FREQ	Transmit frequency	5 to 65 MHz
RX FREQ	Receive frequency	45 to 174 MHz
TX LEVEL	Transmit level	84 to 110 dB $\mu$ V
BAUD RATE	Data speed	9.6-19.2-38.4 kbps
MODE	Transponder mode	IEP

### Accessories

Test adapter, F type                      A71004

### Fuses

Fuse type	Description	PN
T2AH250V	2AT, for 230 V AC	1005108
T5AH250V	5AT, for 24 to 65 V	1005109
T10AL250V	10 AT, for input/output port	A38016

**Notes:** All fuses must be replaced by a similar type.

---

## For Information

---

### If You Have Questions

Region	Centers	Customer Service Numbers
North America	USA	■ Toll-free: 1-800-722-2009
Europe, Middle East, Africa	Belgium	■ Telephone: 32-56-445-133 or 32-56-445-118
Japan	Japan	■ Telephone: 81-3-5908-2153 or +81-3-5908-2154
Korea	Korea	■ Telephone: 82-2-6205-6004
China (mainland)	China	■ Telephone: 86-21-6237-5233
Other Asia-Pacific countries, Australia	Hong Kong	■ Telephone: 852-2522-5059
Brazil	Brazil	■ Telephone: 55-11-3845-9154, ext 109
Mexico, Central America, Caribbean	Mexico	■ Telephone: 52-55-50-81-8425
All other Latin America countries	Argentina	■ Telephone: 770-236-5662

---



5030 Sugarloaf Parkway, Box 465447  
Lawrenceville, GA 30042

678.277.1000

Cisco, Cisco Systems, the Cisco logo, the Cisco Systems logo, Scientific Atlanta, and SciCare are registered trademarks or trademarks of Cisco Systems, Inc. and/or its affiliates in the U.S. and certain other countries.

*All other trademarks mentioned in this document are the property of their respective owners.*  
Product and service availability are subject to change without notice.

© 2008 Cisco Systems, Inc. All rights reserved.  
December 2008

Printed in United States of America  
Part Number 4015252 Rev C