



Prisma II Reverse Video Receiver and Reverse Data Receiver

Installation and Operation Guide







For Your Safety

Explanation of Warning and Caution Icons



Avoid personal injury and product damage! Do not proceed beyond any symbol until you fully understand the indicated conditions.

The following warning and caution icons alert you to important information about the safe operation of this product:

-  **You may find this symbol in the document that accompanies this product. This symbol indicates important operating or maintenance instructions.**
-  **You may find this symbol affixed to the product. This symbol indicates a live terminal where a dangerous voltage may be present; the tip of the flash points to the terminal device.**
-  **You may find this symbol affixed to the product. This symbol indicates a protective ground terminal.**
-  **You may find this symbol affixed to the product. This symbol indicates a chassis terminal (normally used for equipotential bonding).**
-  **You may find this symbol affixed to the product. This symbol warns of a potentially hot surface.**
-  **You may find this symbol affixed to the product and in this document. This symbol indicates an infrared laser that transmits intensity-modulated light and emits invisible laser radiation or an LED that transmits intensity-modulated light.**

Important

Please read this entire guide. If this guide provides installation or operation instructions, give particular attention to all safety statements included in this guide.

Notices

Trademark Acknowledgments

Cisco and the Cisco logo are trademarks or registered trademarks of Cisco and/or its affiliates in the U.S. and other countries. To view a list of cisco trademarks, go to this URL: www.cisco.com/go/trademarks.

Third party trademarks mentioned are the property of their respective owners.

The use of the word partner does not imply a partnership relationship between Cisco and any other company. (1110R)

Publication Disclaimer

Cisco Systems, Inc. assumes no responsibility for errors or omissions that may appear in this publication. We reserve the right to change this publication at any time without notice. This document is not to be construed as conferring by implication, estoppel, or otherwise any license or right under any copyright or patent, whether or not the use of any information in this document employs an invention claimed in any existing or later issued patent.

Copyright

© 2008, 2012 Cisco and/or its affiliates. All rights reserved. Printed in the United States of America.

Information in this publication is subject to change without notice. No part of this publication may be reproduced or transmitted in any form, by photocopy, microfilm, xerography, or any other means, or incorporated into any information retrieval system, electronic or mechanical, for any purpose, without the express permission of Cisco Systems, Inc.

Contents

Safety Precautions	v
Compliance	vii
Laser Safety	viii
Chapter 1	Introduction
Overview	1-1
Introduction.....	1-2
The Front Panel.....	1-5
The Back Panel.....	1-6
Configuration Overview	1-7
Chapter 2	Installation
Overview	2-1
Preparing for Installation	2-2
Site Requirements.....	2-3
Connecting the RF Cables to the Chassis.....	2-6
Installing the Module in the Chassis	2-7
Connecting Optical Cables	2-9
Communications Connections.....	2-12
Master/Slave Connections.....	2-14
Chapter 3	Operation Using the ICIM
Overview	3-1
ICIM Introduction	3-2
The ICIM Front Panel	3-3
The ICIM Password.....	3-6
Operating the ICIM	3-11
Monitoring Operating Status Using the ICIM.....	3-14
Configuring the Reverse Receiver Using the ICIM	3-16
Checking Reverse Receiver Alarms Using the ICIM.....	3-19
Checking Manufacturing Data Using the ICIM.....	3-23
Using the ICIM to Save the Configuration	3-26

Contents, Continued

Chapter 4	Operation Using LCI	
	LCI Introduction.....	4-3
	System Requirements.....	4-4
	Installing LCI.....	4-5
	Connecting your Laptop Computer to the Chassis.....	4-9
	Starting LCI.....	4-10
	LCI Module Tree Overview.....	4-11
	Accessing the Module Details Window.....	4-13
	Checking the Operating Status.....	4-20
	Configuring the Reverse Receiver.....	4-22
	Checking Reverse Receiver Alarms.....	4-25
	Modifying Reverse Receiver Alarm Limits.....	4-27
	Checking Manufacturing Data.....	4-30
Chapter 5	Maintenance and Troubleshooting	
	Overview.....	5-1
	Module Maintenance.....	5-2
	General Troubleshooting Information.....	5-3
	Troubleshooting Alarm Conditions.....	5-4
Chapter 6	Customer Information.....	4-1
Optoelectronic Glossary.....		Glossary-1

Safety Precautions

Protect Yourself From Electric Shock and Your System From Damage!

- This product complies with international safety and design standards. Observe all safety procedures that appear throughout this guide, and the safety symbols that are affixed to this product.
- If circumstances impair the safe operation of this product, stop operation and secure this product against further operation.

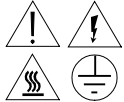

Avoid personal injury and product damage! Do not proceed beyond any symbol until you fully understand the indicated conditions!



You will find this symbol in the literature that accompanies this product. This symbol indicates important operating or maintenance instructions.



You may find this symbol affixed to this product. This symbol indicates a live terminal; the flash points to the terminal device.



You may find this symbol affixed to this product. This symbol indicates a protective earth terminal.



You may find this symbol affixed to this product. This symbol indicates excessive or dangerous heat.

Safety Precautions, Continued

Factory Service

Refer service only to service personnel who are authorized by the factory.

Enclosure

- Do not allow moisture to enter this product.
- Do not open the enclosure of this product unless otherwise specified.
- Do not push objects through openings in the enclosure of this product.

Cables

- Always pull on the plug or the connector to disconnect a cable. Never pull on the cable itself.
- Do not walk on or place stress on cables or plugs.

Compliance

Laser and Electrical Safety

UL 1419:1997: A sample of this equipment has been tested and found to meet the requirements of UL 1419:1997.

CSA C22.2 No. 1:1994: A sample of this equipment has been tested and found to meet the requirements of CSA C22.2 No. 1:1994.

CFR 21:1996: A sample of this equipment has been tested and found to meet the requirements of CFR 21:1996.

Electromagnetic Compatibility

FCC Part 15 Subpart B: This equipment has been tested and found to comply with the limits for a Class A digital device according to Part 15 of FCC Rules. These limits are designed to provide reasonable protection against harmful interference when the equipment is operated in a commercial environment.

This equipment generates, uses, and can radiate radio frequency energy and, if not installed and used in accordance with the instruction manual, may cause harmful interference to radio communications. Operation of this equipment in a residential area is likely to cause harmful interference in which case the user will be required to correct the interference at his own expense.

Laser Safety

Introduction

This product receives intensity-modulated light and emits invisible radiation.

Warning: Radiation

 **WARNING:**

- **Avoid personal injury! Use of controls, adjustments, or procedures other than those specified herein may result in hazardous radiation exposure.**
- **Avoid personal injury! The laser light source on this product emits invisible laser radiation. Avoid direct exposure to the laser light source.**

- Do not apply power to this product if the fiber is unmated or unterminated.
- Do not stare into an unmated fiber or at any mirror-like surface that could reflect light that is emitted from an unterminated fiber.
- Do not view an activated fiber with optical instruments.

Warning: Fiber Chips

 **WARNING:**

Avoid personal injury! Wear safety glasses and use extreme caution when you handle the glass chips that are inside the cladding of the optical fiber. X-ray cannot detect these glass chips if they become embedded in the skin. Place the chips immediately in a small waste container and discard.

Modifications

Do not make modifications to this product without the approval of Cisco.

Whenever modifications that may affect hazard levels are made to the optical fiber communication system, the person or organization that performs such modification must reassess hazard levels. They must do this by conducting tests and measurements wherever appropriate for the ensurance of compliance. If there is a change in the hazard level, they must re-label this product.

Laser Safety, Continued

Laser Warning Labels

This module bears the following labels.



Chapter 1

Introduction

Overview

Introduction

This chapter describes the front and back panels, and gives a setup summary for the Prisma II™ Reverse Video Receiver and the Prisma II Reverse Data Receiver.

This guide covers the two following products.

- Prisma II Reverse Data Receiver (data grade)
- Prisma II Reverse Video Receiver (data/video grade)

Installation procedures and most operational procedures are identical for both products.

Qualified Personnel

Only appropriately qualified and trained personnel should attempt to install this product.



WARNING:

Allow only qualified personnel to install, operate, maintain, and service this product. Otherwise, personal injury or equipment damage may occur.

In This Chapter

This chapter contains the following topics.

Topic	See Page
Introduction	1-2
The Front Panel	1-5
The Back Panel	1-6
Configuration Overview	1-7

Introduction

Overview

The Prisma II Reverse Video Receiver and the Prisma II Reverse Data Receiver are part of a family of products in the Prisma II product line. These two reverse receivers are plug-in modules for the Prisma II platform.

These products are indoor reverse receivers capable of receiving reverse path optical signals from a reverse transmitter.

Features

The Prisma II Dual Reverse Receivers have the following features:

- Front panel green LED to indicate operating status
- Front panel red LED to indicate alarm status
- -20 dB test point
- Optical input connectors
- Plug-and-play capability
- Compatible with Cisco LCI and TNCS software
- Blind mate RF connections

Introduction, Continued

Prisma II Reverse Receiver Operation

The two reverse receivers are used in conjunction with a reverse transmitter to receive reverse path signals to the hub or headend.

The two reverse receivers each contain two separate optoelectronic receivers. Optical input is through two optical connectors mounted on the front of the module. The RF output is through two connectors on the rear of the module.

In the reverse receiver, the optical signal is detected by a photodiode and is converted to an electrical signal. The electrical signal is then sent to an RF amplifier with approximately 24 dB of gain for the video/data module, and approximately 30 dB of gain for the data only module. The RF signal goes to its respective output connector on the rear of the module.

Using the ICIM, LCI, or TNCS, each RF output may be attenuated as much as 20 dB relative to no attenuation, in 0.5 dB increments. The actual RF output levels of the dual reverse receiver (minus 20 dB) can be monitored at the two -20 dB test points on the front panel.

The reverse receiver can be controlled by an ICIM, the LCI software, or the TNCS software.

Optical Input

Depending on how you ordered your system, the optical input connectors may either be an SC/APC, SC/UPC, FC/UPC, or E2000/APC.



WARNING:

Avoid damage to your eyes! Do not look into any optical connector while the system is active. Even if the unit is off, there may still be hazardous optical levels present.

Introduction, Continued

Block Diagram

A block diagram of the Prisma II Reverse Receiver is shown below.

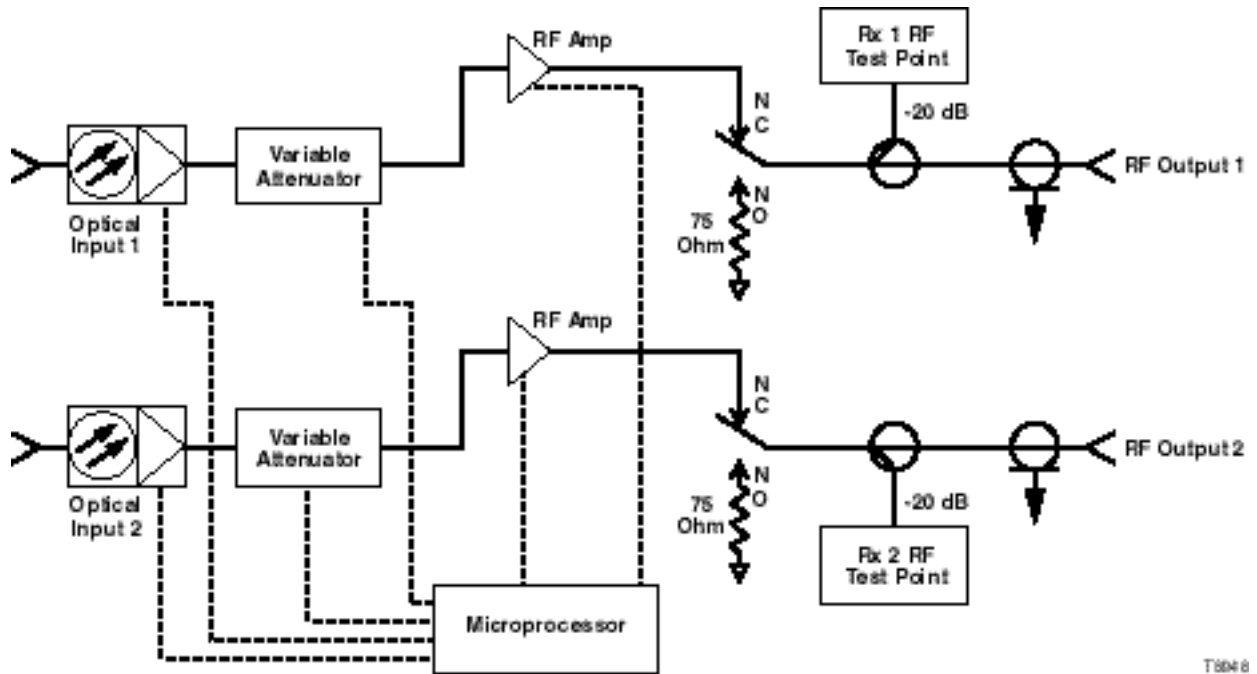

Table 8

The Front Panel

Overview

The Prisma II Reverse Receiver's front panel is designed with two optical connectors for optical input and two test points for RF output verification. All are easily accessible. ALARM and Power ON indicators on the front panel allow you to monitor power and alarm status at a glance.

The features of the front panel of the two Prisma II Reverse Receivers are shown below.

Part	Function
Alarm indicator	Illuminates or blinks when an alarm condition occurs
Power indicator	Illuminates when power is supplied to the module.
Optical input	Connects the optical cable to the input of the reverse receiver.
-20 dB test points	Provides a -20 dB sample of the RF output signal

Illustrations

The front panels of the two Prisma II Reverse Receivers are shown below.

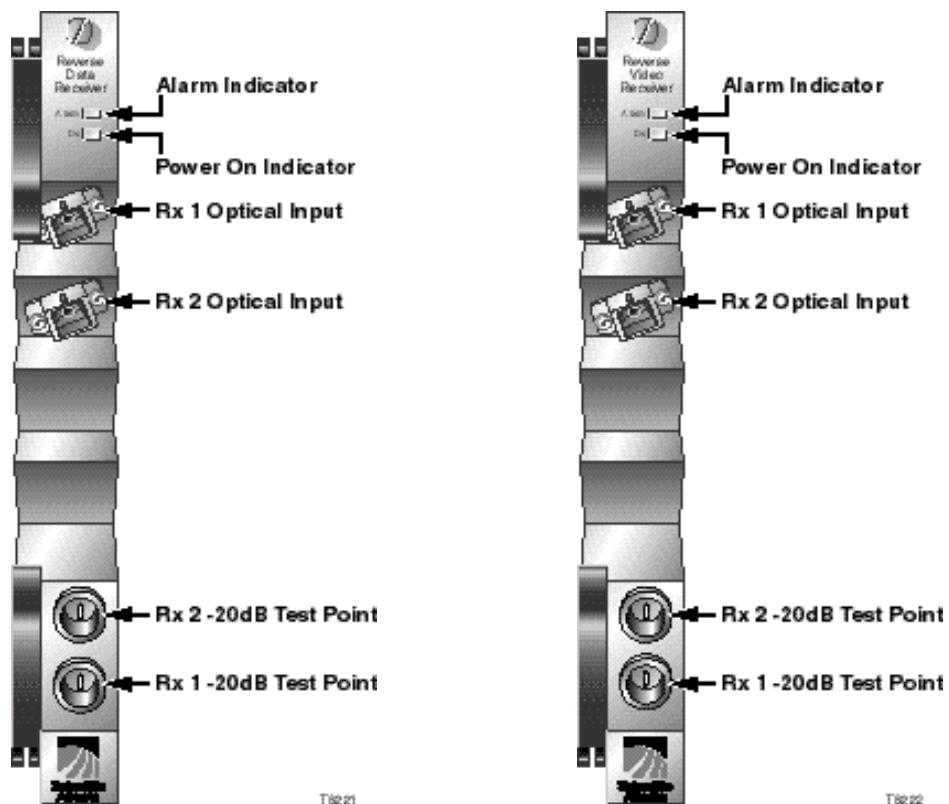

The Back Panel

Back Panel Connectors

Blind-mate connectors make it easy to install this module. The connector on the back of the module mates with a connector on the inside of the chassis. The 110-pin connector provides the following:

- Electrical power input
- Alarm communications
- Status-monitoring connections
- Communications and control connections

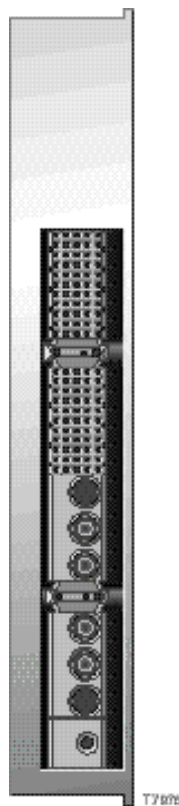

Power and Communications Connector

The power and communications connector on the back of the module mates with a connector inside of the chassis, and supplies power from the chassis to the transmitter. The 110-pin connector also routes alarm and status-monitoring information from the receiver to the Prisma II Chassis.

Configuration Overview

Overview

The Prisma II Reverse Receivers are shipped from the factory with operational parameters set to factory defaults. However, you will probably choose to configure the operating parameters so that they are best suited for your application.

Configuration and Monitoring Methods

The reverse receiver may be controlled using one of three different methods.

- The Prisma II Intelligent Communications Interface Module (ICIM)

If an ICIM is installed in the Prisma II Chassis, it may be used to configure and monitor Prisma II application modules within its domain. For instructions on operating this module using the ICIM, refer to Chapter 3, **Operation Using the ICIM**.

- The Local Craft Interface (LCI) software

The Local Craft Interface (LCI) software running on a locally connected PC may be used to configure operating parameters of Prisma II modules. For instructions on operating this module using the LCI software, refer to Chapter 4, **Operation Using LCI**.

- Cisco's Transmission Network Control System (TNCS) software.

If the ICIM is installed, TNCS software may be used to configure and monitor all functions of the Prisma II modules. For instructions on operating this module using TNCS, refer to the *TNCS Administrator Software User's Guide*, part number 730201.

Configuration Summary

Using any of the above methods, you can configure the following:

- Enable or disable each receiver
- Force Mute
- Force Alarm
- Master or slave operation
- Attenuation level

For detailed information on configuring this module, see the Chapter 3, **Operation Using the ICIM**, or Chapter 4, **Operation Using LCI**, of this guide.

Chapter 2 Installation

Overview

Introduction

This chapter contains instructions, site requirements, equipment, and tools needed to install the Prisma II Reverse Receiver.

Qualified Personnel



WARNING:

Allow only qualified personnel to install, operate, maintain, or service this product. Otherwise, personal injury or equipment damage may occur.

In This Chapter

This chapter gives step-by-step instructions on installing the Prisma II Dual Reverse Receiver.

Topic	See Page
Preparing for Installation	2-2
Site Requirements	2-3
Connecting the RF Cables to the Chassis	2-6
Installing the Module in the Chassis	2-7
Connecting Optical Cables	2-9
Communications Connections	2-12
Master/Slave Connections	2-14

Preparing for Installation

Overview

Before you begin, make sure that the module is in good condition and that you have the tools and equipment listed here.

Unpacking and Inspecting the Module

As you unpack the module, inspect it for shipping damage. If you find any damage, contact Cisco. Refer to Chapter 6 for information on contacting Cisco Services.

Equipment and Tools Needed

Before you begin, make sure that the module is in good condition. You need the following equipment and tools to install these modules.

You need . . .	To . . .
a Prisma II Chassis with power supply	provide housing, power and input/output connections to the module.
3/8-in. flat-blade screwdriver	secure the module in the chassis.
two optical cables with connectors	carry optical input signals.

Site Requirements

Overview

Before you begin, make certain that your installation site meets the requirements discussed in this section.

Access Requirements

Ensure that only authorized personnel have access to this equipment. Otherwise, personal injury or equipment damage may occur.



WARNING:

Use this product in locations that restrict access to all persons who are not authorized. Otherwise, personal injury or equipment damage may occur.

Equipment Rack

To install this module, your site must be equipped with an Electronics Industry Association (EIA) equipment rack that properly houses the Prisma II Chassis with proper spacing for air circulation. For instructions on installing the chassis in the rack, refer to the guide that was shipped with the chassis.

Operating Environment



CAUTION:

Avoid damage to this product! Operating this product above the maximum operating temperature specified voids the warranty.

Follow these recommendations to maintain an acceptable operating temperature.

- Temperature inside the rack must be between -40°C and 65°C (-40°F and 149°F)
- Keep cooling vents clear and free of obstructions.
- Provide ventilation, as needed, using one or more of the following methods.
 - air-deflecting baffles
 - forced-air ventilation
 - air outlets above enclosures

Site Requirements, Continued

Power Requirements

Prisma II modules receive their electrical power from the Prisma II Chassis. The module may be installed with the chassis powered-up.

Space Requirements

This module is a single-width module. It is usually installed in slots five through sixteen. Slots one through four are usually reserved for the power supplies. Slots fifteen and sixteen are reserved for the Intelligent Communications Interface Module (ICIM), if installed. If an ICIM is not installed, any other module could be installed in these slots. Slot 2 and slot 4 are reserved for an internal power supply if installed. If an internal power supply is not installed here, any other module could be installed in these slots.

Chassis Style

The Prisma II Chassis may be configured as front access or rear access depending on the system you have purchased. Power, RF input or output, and other connectors may be located on either the front or rear of the Prisma II Chassis. Connections to the chassis serve the same function and are made in the same manner regardless of the location of the connectors or chassis configuration.

Site Requirements, Continued

Rear Access Chassis Illustration

The Prisma II Chassis may be configured as front access or rear access depending on the system you have purchased. The rear access chassis is shown here.

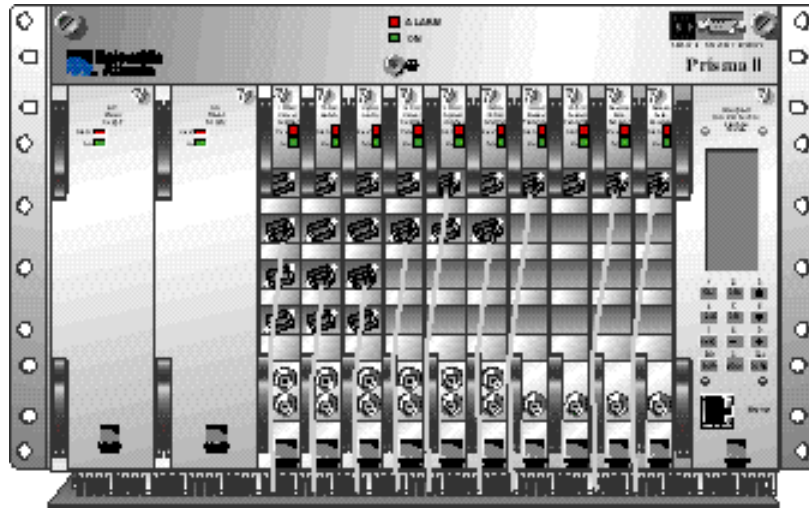

Ta036

Front Access Chassis Illustration

The front access chassis is shown here.

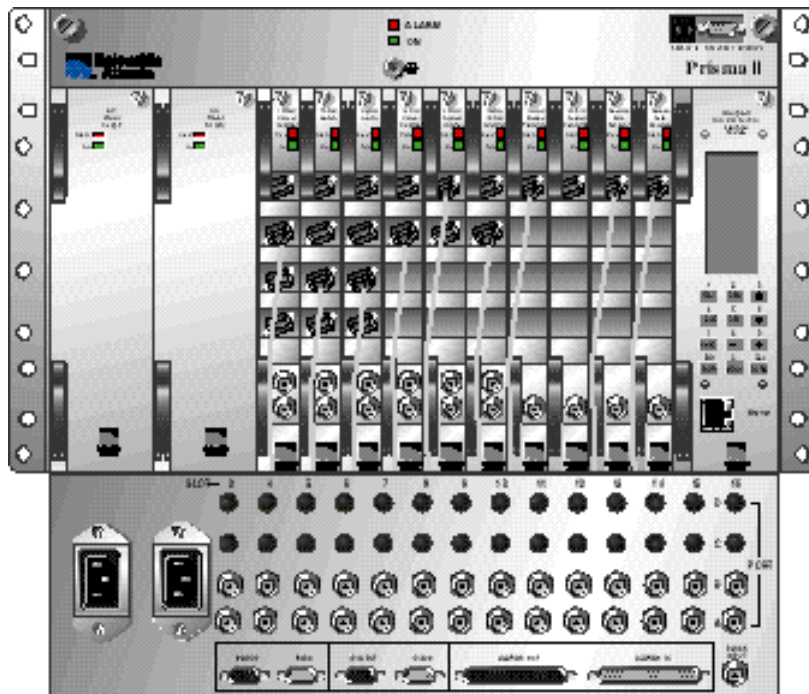

Ta035

Connecting the RF Cables to the Chassis

RF Cable Connection Procedure

Important: This procedure assumes the Prisma II Chassis is mounted in a rack. Follow this procedure to make the RF connections for each module to be installed.

1. At the front/rear of the Prisma II Chassis, locate the RF ports.

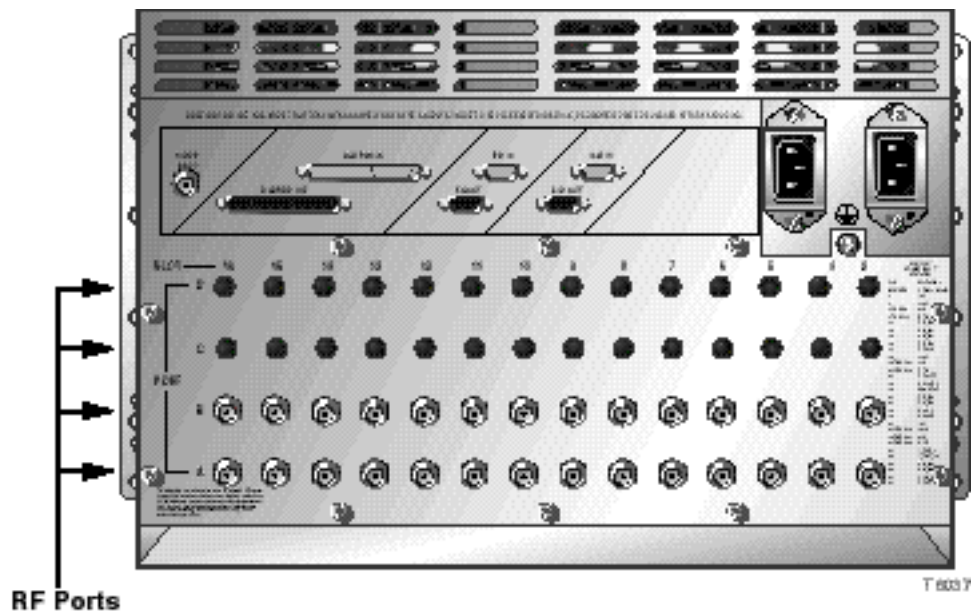

Note: RF Ports are located on the front of front access chassis.

2. Attach an RF cable to the Port A connector (RF output) of the corresponding slot where the module is to be installed. This is the RF output connection.

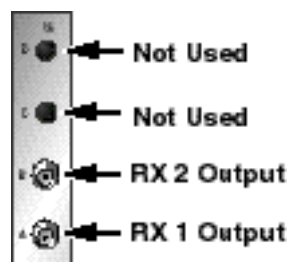

3. Route the RF cable from Port A to the appropriate RF destination.
4. Connect another RF cable to Port B (RF output) of the slot where the module is installed. Hand-tighten the connector.
5. Route the RF cable from Port B to the appropriate RF destination.
6. If F-connectors are installed, use a 7/16-in. open-end wrench to secure both cables to the connectors at the chassis.

Installing the Module in the Chassis

Installing the Module

Important: The following procedure assumes the Prisma II chassis is mounted in a rack. This procedure applies to both chassis styles.

To install the module in the chassis, follow these steps.

1. Locate the fiber guides at the bottom of the chassis and the module guide slots inside the chassis as shown in the following illustration.

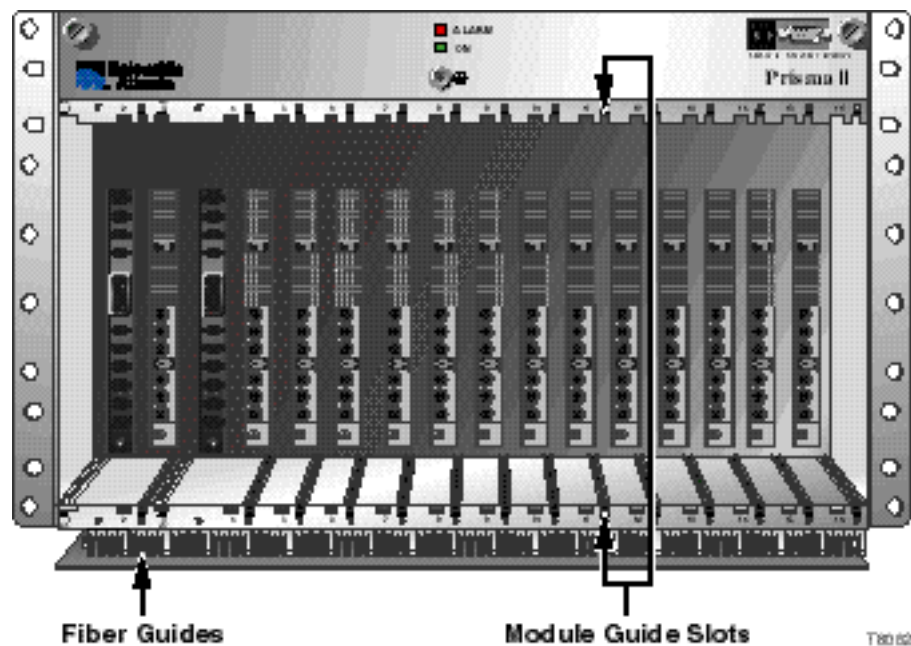

2. Align the ridges on the top and bottom of the module with the module guide slots located on the chassis. Module ejectors must be fully extended when inserting the module.

Installing the Module in the Chassis, Continued

3. Gently slide the module into the chassis until you feel the connectors on the back of the module join the receptacles at the back of the slot. Use the module ejector to lock the module in place.

Note: Do not force or bang the module into the chassis. If properly aligned, it will slide in with minimal force.

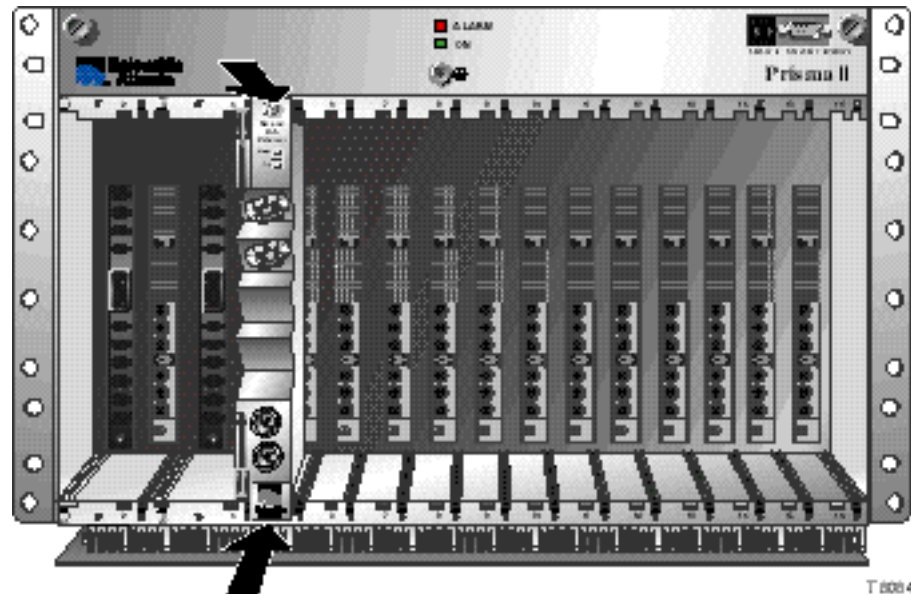

4. Secure the module by pressing the two ejectors located on the left side of the module until they lock. When the levers are locked, the power and communications connections at the rear of the module mates with the communications connectors at the back of the chassis slot.
5. Hand-tighten the screw at the top of the module, to secure it in the chassis. Use a $\frac{3}{8}$ -in. flat-blade screwdriver to secure. **Do not over tighten.**

Connecting Optical Cables

The Fiber Fish Tool

The Fiber Fish tool that was shipped along with the Prisma II Chassis is used to pull an optical cable from the rear of the chassis to the front of the chassis so the optical cables can be connected to optical connectors on the front panel of Prisma II modules.

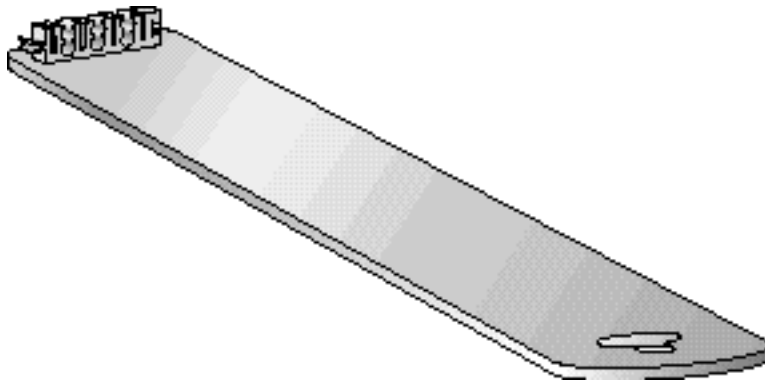

The Fiber Fish Tool Hook

At the end of the Fiber Fish tool is a small hook that allows you to hold an optical cable so that you can pull it through to the front panel of Prisma II Chassis.

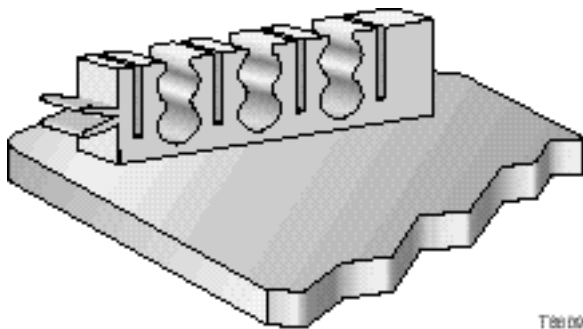

Connecting Optical Cables, Continued

Using the Fiber Fish to Pull the Optical Cable to the Prisma II Module

To get an optical cable to the module follow these procedures.

1. Insert the Fiber Fish tool through the slot located just above the bottom of the chassis.
2. At the rear of the chassis, locate the appropriate optical cable.
3. Insert the optical cable into notched area of Fiber Fish tool as shown.

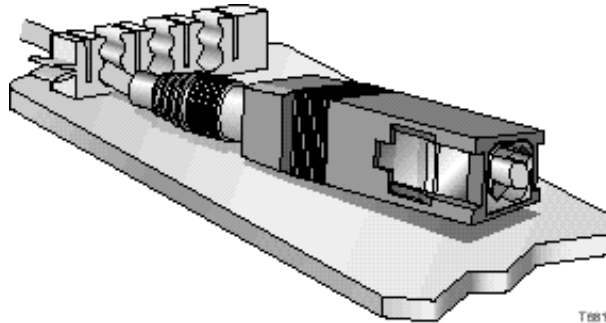

4. At the front of the chassis, pull the Fiber Fish tool (with cable attached) to the front of the chassis.
5. Disengage the optical cable from the Fiber Fish tool and attach to the appropriate connector on desired module. See **Cable Connection Procedure**.

Connecting Optical Cables, Continued

Cable Connection Procedure

Follow this procedure to make the optical cable connections for each module to be installed.

1. Attach one end of the optical cable to the RX1 optical input connector (connector 1), located on the front of the Prisma II Reverse Receiver.

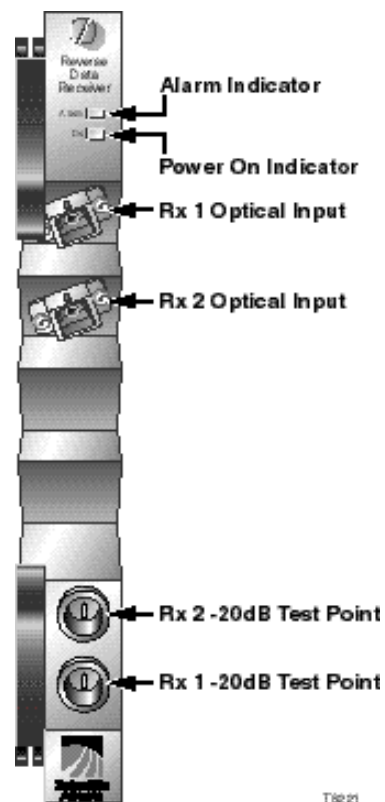

2. Route the other end of the optical cable to the appropriate destination.
3. Repeat steps 1 and 2 for the RX2 optical input connector.

Communications Connections

ICIM IN/ICIM OUT and EM IN/EM OUT Cables

The Prisma II platform allows several chassis to be interconnected. These connections allow the modules to communicate with the ICIM and also allow ICIM to communicate with TNCS.

Chassis with an ICIM are connected in series to each other with an ICIM via EM IN/OUT connectors. All other chassis within each ICIM's domain are connected in series via the ICIM IN/OUT connector. For more information on chassis communications, see **Communications Connections** in Chapter 2 of *Prisma II Chassis Installation and Operation Guide*, part number 713375.

The cable required for the ICIM IN/ICIM OUT chassis connection is identical to the EM IN/EM OUT cable. This cable is a standard "off the shelf" serial extension cable, DB9 Female to DB9 Male. This cable can be purchased at your local computer store.

The Cisco part number for a 6-foot DB9 Female to DB9 Male extension cable is 180143.

The connectors are a Serial - 9 pin D-shell (EIA 574/232).

EM IN/EM OUT to TNCS Cable

The connection from the Prisma II Chassis to the TNCS connection requires a special cable kit available from Cisco. Prisma II Cable Kit, part number 738686, includes the following cables:

- 1ea Prisma II Cable Assembly
- 1ea DB9 to DB9 Cable Assembly, 10 foot
- 4ea DB9 to DB9 Cable Assembly, 3 ½ foot

ICIM IN/ICIM OUT Connections

The Prisma II platform allows multiple chassis to be connected for module to ICIM communications. This connection is required for all chassis intended to be controlled by a given ICIM.

Note: An ICIM can control a maximum of 82 modules. Depending on your application this is typically 6 to 7 chassis. Do not exceed these limits.

The chassis has two DB9 connectors for the ICIM to module connections. ICIM OUT is a male connector and ICIM IN is a female connector.



Communications Connections, Continued

ICIM IN/ICIM OUT Connection Procedure

To make ICIM IN/ICIM OUT connections, follow these steps.

1. Connect the DB9 to DB9 cable, part number 180143 or equivalent, from the ICIM OUT of the chassis containing the ICIM to the ICIM IN connector of the second chassis.
2. Connect a DB9 to DB9 cable from the ICIM OUT of the second chassis to the ICIM IN of the third chassis.
3. Continue this “daisy-chain” connection until all desired chassis are connected.

Notes:

- All chassis connected in this “daisy-chain” must be powered and have a fan tray installed. A chassis that is connected but is either not powered, or does not have a fan tray installed will cause faulty operation of the ICIM.
- All chassis connected in this “daisy-chain” must have a unique chassis I.D. number.

EM OUT / IN Connections

The Prisma II platform allows the interconnection of multiple ICIMs located in separate chassis. This connection is required for all ICIMs that you intend to monitor using TNCS and must be completed between each chassis containing an ICIM.

The back panel of the chassis has two DB9 connectors for the TNCS to ICIM connection. The EM OUT is a male connector and the EM IN is a female connector.



EM OUT / EM IN Connection Procedure

To make EM IN/EM OUT connections, follow these steps.

1. A connection is required from the first chassis containing an ICIM to the TNCS system. The Prisma II Cable Kit (738686) is required for this connection. Connect this cable to the EM IN of the first chassis containing an ICIM.
2. Utilizing a DB9 to DB9 cable (180143 or equivalent), connect the EM OUT of the first chassis to the EM IN of a second chassis containing an ICIM.
3. Continue this “daisy-chain” connection until all chassis containing an ICIM are connected.

Master/Slave Connections

Master/Slave Operation

The Prisma II Reverse Receiver ships from the factory configured as a "Master". LCI, TNCS, or the ICIM can be used to reconfigure the module as a "Slave." The Prisma II Chassis allows for local hard-wired redundancy by using the ALARM IN and ALARM OUT connectors located on the chassis. You can configure a pair of modules so that if the master fails, the slave will take over.

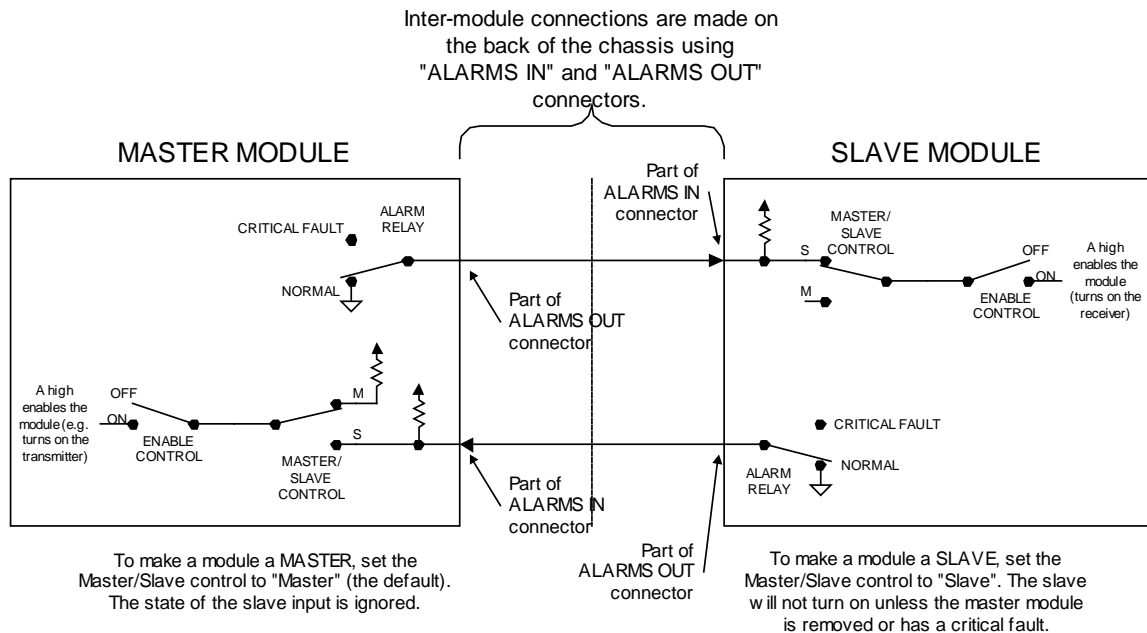

Notes:

- The ALARM RELAYS are shown in their NORMAL (non-alarmed) state. When a CRITICAL FAULT occurs, the relay changes to the open state.
- Then ENABLE CONTROL is shown in its OFF position. LCI, TNCS, or the ICIM can be used to change its position.

Alarm In/Out Connector Reference

For ALARMS IN/OUT pin connector reference, see **Alarm I/O and Master/Slave Chassis Connections** in Chapter 2 of *Prisma II Chassis Installation and Operation Guide*, part number 713375.

Master/Slave Connections, Continued

A module configured as a slave normally has its output turned off or disabled. When a critical alarm occurs in the master module, the master turns off and the slave module turns on. To make that happen, the ALARM OUT contacts from the master's slot must be wired to the ALARM IN contacts on the slave 's slot. Once those contacts are wired, care must be taken to ensure that the master and slave modules don't change slots (otherwise the ALARM IN and ALARM OUT connectors will need to be rewired).

Note that any device configured as a master ignores its ALARM IN contacts.

One way to verify proper wiring and configuration is to simply unplug the master device and observe that the slave device turns on.

Chapter 3

Operation Using the ICIM

Overview

Introduction

The procedures in this chapter apply if you are using the Prisma II Intelligent Communications Interface Module (ICIM) to configure and operate the Prisma II Reverse Receivers.

Scope of this Chapter

Included in this chapter are descriptions of the ICIM front panel and the ICIM LCD, and detailed procedures on how to use the software menus to configure the module.

In This Chapter

This chapter contains the following topics.

Topic	See Page
ICIM Introduction	3-2
The ICIM Front Panel	3-3
The ICIM Password	3-6
Operating the ICIM	3-11
Monitoring Operating Status Using the ICIM	3-14
Configuring the Reverse Receiver Using the ICIM	3-16
Checking Reverse Receiver Alarms Using the ICIM	3-19
Checking Manufacturing Data Using the ICIM	3-23
Using the ICIM to Save the Configuration	3-26



WARNING:

Avoid damage to your eyes! Do not look into any optical connector while the system is active. Even if the unit is off, there may still be hazardous optical levels present.

ICIM Introduction

ICIM Function

The ICIM functions as the module-user interface as well as the interface between the Prisma II modules and the Transmission Networks Control Systems (TNCS). The ICIM allows local module configuration and status monitoring for up to 82 modules located in multiple chassis. The ICIM features easy-to-use software that is navigated using the numeric keypad and the LCD display.

Important: Do not operate any Prisma II Chassis without a fan tray installed properly. If a fan tray is not installed in the Prisma II Chassis, the ICIM will not communicate with any of the modules in that chassis.

Important: All chassis connected in a “daisy-chain” must be powered and have a fan tray installed. A chassis that is connected but is either not powered, or does not have a fan tray installed will cause faulty operation of the ICIM.

Important: All chassis connected in this “daisy-chain” must have a unique chassis I.D. number.

ICIM Block Diagram

The ICIM is illustrated in the block diagram below.

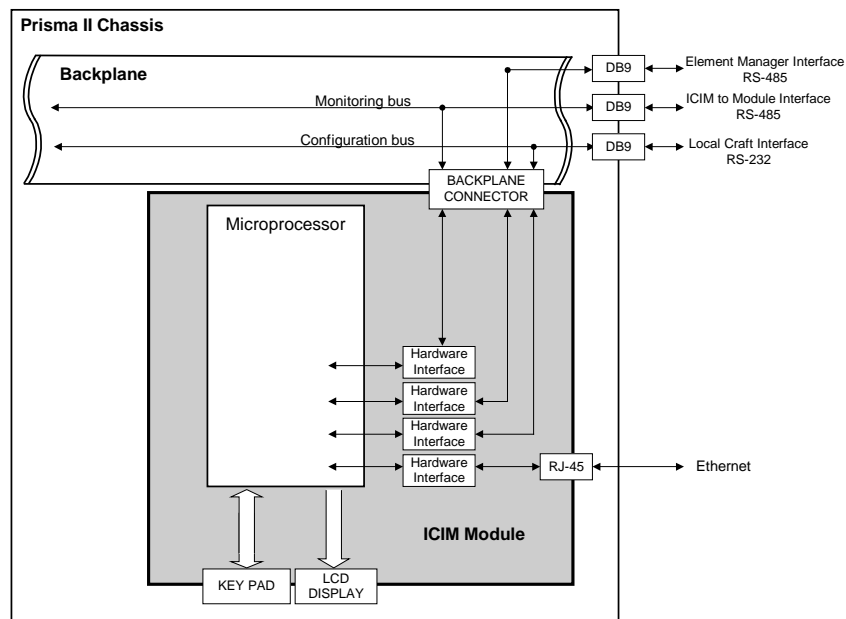

The ICIM Front Panel

ICIM Front Panel Illustration

The following illustration shows the front panel of the ICIM.

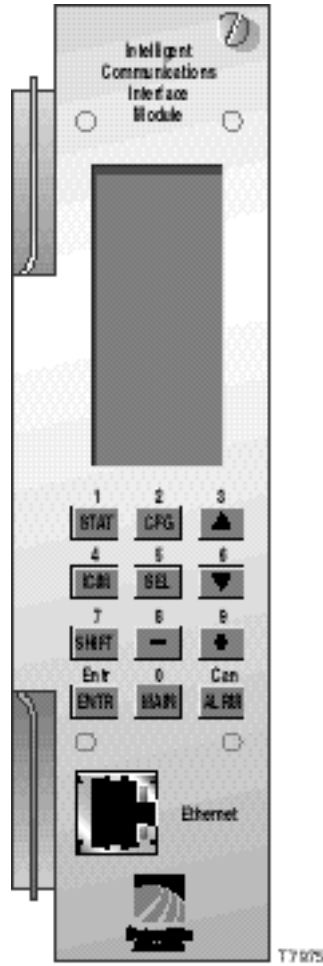

Continued on next page

The ICIM Front Panel, Continued

ICIM Front Panel Features

Part	Function
LCD screen	Displays the ICIM menus, alarms, and status information.
12-key numeric keypad	Used to navigate the ICIM's menus and configure the application modules.
Ethernet Connector	Directly connects the ICIM to a network (future release).

The ICIM LCD

The ICIM LCD is the operator's visual link to the ICIM software. When the ICIM is installed and powered up, the **MAIN** menu is displayed on the LCD. The following illustration shows the ICIM's **MAIN** menu.

MAIN

Offline

Modules
15

Alarms
0

Scroll













Module
Shelf
Slot

Continued on next page

The ICIM Front Panel, Continued

The ICIM Key Pad

The ICIM keypad has twelve keys that allow you to input and monitor operational parameters. The table below lists each key and a brief description of its function.

Button	Function
	Displays status information for the selected module
	Displays configuration information for the selected module
	Displays all of the parameters in alarm for a selected module
	Moves the menu selection area up. Also increases numerical readings of selected configuration parameters
	Moves the menu selection area down. Also decreases numerical readings of selected configuration parameters
	Selects the highlighted parameter
	Displays ICIM module information such as firmware version, serial number, and baud rate
	Shifts function of a keypad button to the function or number label just above that button.
	Decreases numerical readings of selected configuration parameters
	Increases numerical readings of selected configuration parameters
	Enters input data (if valid)
	Exits the current menu and displays the MAIN ICIM menu

The ICIM Password

Using the ICIM Password

The ICIM allows you to send configuration commands, to change alarm thresholds, and restore factory default settings in Prisma II modules. In order to ensure that no unauthorized changing of these parameters occurs, you have the option of using a password protection system. Password authorization only applies to the configurable parameters. Status and alarm information is always available on the ICIM regardless of password implementation.

The password system consists of:

- A user-settable password - **User Psw.** The user password is created, entered, and changed through the ICIM keypad and displayed on the ICIM LCD. The password must be exactly eight digits using only the 0-9 number keys.
- A service password - **SA Psw.** Used only by Cisco personnel.
- The ability to change an existing user password - **Change Psw.**
- The ability to disable the user password function - **Disable Psw.**

Important: If you only want to monitor status and alarm data, simply skip the password function when it appears on the ICIM menu. You can access all module status and alarm information without a password. However, once a user password is entered, you are required to enter it every time you want to set configurable parameters to any module controlled by that ICIM. See **Expired Password or Inactive Password Messages** and **Entering the User Password** that follow.

Continued on next page

The ICIM Password, Continued

Accessing the Password Menu

The Password menu allows you to create, enter, change, or disable the user password. It also allows service personnel to use the Cisco password. To access the Password menu, follow the steps below.

1. Press the **ICIM** key.
2. Use the **▼** key to scroll down until **Password** is highlighted.
3. Press the **SEL** key. The Password menu is displayed. **User Psw** is highlighted.

MAI N ----- Off l i n e ----- Mod u l e s 0 A l a r m s 0 ----- Sc r o l l ----- Mod u l e Sh e l f S l o t	ICIM ----- Sh e l f 7 S l o t 1 5 ----- M f g D a t a ----- P a s s w o r d ----- U p d a t e A d r	ICIM ----- Sh e l f 7 S l o t 1 5 ----- M f g D a t a ----- P a s s w o r d ----- U p d a t e A d r	ICIM ----- Sh e l f 7 S l o t 1 5 ----- U s e r P s w ----- S A P s w ----- C h a n g e P s w ----- D i s a b l e P s w
--	--	--	---

Expired Password or Inactive Password Messages

The entry of a valid password allows changes to system parameters for a period of 10 minutes. If more than 10 minutes has passed since your last keystroke, and you attempt to make any changes to system parameters, the menu displays **Psw Expired**. If, after more than 10 minutes, you attempt to disable the password the menu displays **Failed, Password Not Active**. If either of these messages is displayed, you are required to re-enter the password. To re-enter the password, follow the procedure in the next section, **Entering the User Password**.

Continued on next page

The ICIM Password, Continued

Entering the User Password

If you wish to use the user password feature, you must create and enter a password of exactly eight digits using only the 0-9 number keys. The password remains active for 10 minutes after your last keystroke. If you want to change configuration parameters after more than 10 minutes, you are required to re-enter your password. To enter a user password, follow the steps below.

1. Access the Password menu as shown earlier in **Accessing the Password Menu**.
2. Press the **SEL** key. The user password menu is displayed.
3. When **User Psw/Shift Off** is displayed, press the **SHIFT** key to display **Shift On** - then enter the eight digits of your password, using the 0-9 number keys. If at any time you input a digit that is incorrect or you wish to change a digit, use the **CAN** (Cancel) function by pressing the **ALRM** key to delete that digit.
4. Press the **ENTER** key to enter the password. The ICIM updates the display to show if your password entry was accepted or rejected. If the entry was accepted you are able to return to the MAIN menu.
5. If the password you entered is rejected, press the **SHIFT** key to return to the password menu, then re-enter an 8-digit password using only the 0-9 number keys. Press the **ENTER** key to input the password.

Reasons for a password to be rejected include:

- Entering more than eight digits for the password
- Pressing keys other than the 0-9 number keys
- Entering an incorrect password if a valid password has been entered

ICIM	ICIM	ICIM	ICIM
----- Shelf 7 Slot 15 ----- User Psw -----	----- Shelf 7 Slot 15 ----- User Psw * * * * * -----	----- Shelf 7 Slot 15 ----- User Psw 1 2 3 4 * * * * -----	----- Shelf 7 Slot 15 ----- User Psw 1 2 3 4 5 6 7 8 -----
Shift Off	Shift On	Rejected Shift Off	Accepted Shift Off

Continued on next page

The ICIM Password, Continued

Changing the User Password

If a user password has been entered, it may be changed. However, the current password must be active prior to changing it. If the current password has expired (more than 10 minutes have passed since your last keystroke), you must re-enter the current password before changing to a new one.

1. Access the Password menu as shown in the procedure **Accessing the Password Menu**.
2. Use the key to scroll down until **Change Psw** is highlighted.
3. Press the key to select **Change Psw**.
4. When **Change Psw/Shift Off** is displayed, press the key to display **Shift On** - then enter the eight digits of your new password, using the 0-9 number keys. If at any time you input a digit that is incorrect or wish to change a digit, use the **CAN** (Cancel) function by pressing the key to delete that digit.
5. Press the key to input the new password. The ICIM updates the display to show if your password entry was accepted or rejected. If the entry was accepted you are able to return to the MAIN menu.
6. If the new password you entered is rejected, press the key to return to the password entry menu. Clear all digits using the **CAN** (Cancel) function, then re-enter an 8-digit password using only the 0-9 number keys. Press the key to input the password.

I C I M ----- Shelf 7 Slot 15 ----- User Psw ----- SA Psw ----- Change Psw ----- Disable Psw	I C I M ----- Shelf 7 Slot 15 ----- Change Psw ----- Shift Off	I C I M ----- Shelf 7 Slot 15 ----- Change Psw * * * * * ----- Shift On	I C I M ----- Shelf 7 Slot 15 ----- Change Psw 8 7 6 5 4 3 2 1 ----- Shift On
---	---	---	---

Continued on next page

The ICIM Password, Continued

Disabling the User Password

If a user password has been entered, you may disable it at any time. However, the current password must be active prior to disabling it. If the current password has expired (more than 10 minutes have passed since your last keystroke), you must re-enter the current password before disabling it.

1. Press the **ICIM** key.
2. Use the **▼** key to scroll down until **Password** is highlighted.
3. Press the **SEL** key.
4. Use the **▼** key to scroll down until **Disable Psw** is highlighted.
5. Press the **SEL** key to select **Disable Psw**.
6. If the current password is active, the menu displays **Password Is Now Disabled**. You can now make changes to parameters without any password.
7. If the current password has expired (more than 10 minutes have passed since your last keystroke), the menu will display **Failed, Password Not Active**. You must re-enter the current password and then repeat this procedure.

ICIM	ICIM	ICIM
----- Shelf 7 Slot 15 ----- User Psw ----- SA Psw ----- Change Psw ----- Disable Psw -----	----- Shelf 7 Slot 15 ----- Enter Psw 8765 * * * * ----- Password Is Now Disabled ----- Shift Off	----- Shelf 7 Slot 15 ----- Enter Psw 87654321 ----- Failed, Password Not Active ----- Shift Off

Operating the ICIM

Using the ICIM

Once the module is installed as described in Chapter 2, it runs without the aid of an operator. Unless alarms are generated or your system configuration changes, you should not need to make any adjustments to the module beyond the initial setup.

Accessing the ICIM LCD Contrast

To access the ICIM LCD contrast control from the MAIN menu, press the **ICIM** key. Use the **+** key to increase or the **-** key to decrease ICIM display contrast.

The MAIN Menu

A few seconds after power-up, the MAIN menu (shown below) is displayed. Press the **SEL** key to select the specific option.

Display	Description
Offline	Indicates TNCS communication status with the ICIM.
Modules	Indicates the number of modules in the ICIM domain.
Alarms	Displays the number of modules that are in alarm. Selecting this option allows scrolling through all modules in alarm condition.
Scroll	Allows scrolling through all modules in the ICIM domain.
Module Shelf Slot	Allows selection of any specific module in the ICIM domain.

MAIN

Offline

Modules
15

Alarms
0

Scroll

Module
Shelf
Slot

Continued on next page

Operating the ICIM, Continued

Prisma II ICIM Menu

To display the ICIM menu, press the **ICIM** key. The ICIM menu (shown below) is displayed. Press the **SEL** key to select the specific option.

Display	Description
Shelf Slot	Displays the location of the ICIM module.
Mfg Data	Displays manufacturing data about the ICIM.
Password	Allows you to enter, change, or disable a system password. See Using the ICIM Password earlier in this chapter.
Update Adr	If the Chassis ID number switch has been changed, you must highlight the Update Adr menu and press the SEL key for the ICIM to recognize the change.

ICIM	
Shelf	7
Slot	15

Mfg Data	

Password	

Update Adr	

ICIM	
Shelf	7
Slot	15

Mfg Data	

Password	

Update Adr	

ICIM	
Shelf	7
Slot	15

Mfg Data	

Password	

Update Adr	

Continued on next page

Operating the ICIM, Continued

Prisma II MAIN Menu and ICIM Menu Structure

Pressing the **MAIN** key initiates the MAIN software menu. Pressing the **ICIM** key initiates the ICIM software menu. The MAIN and ICIM software structures are shown below.

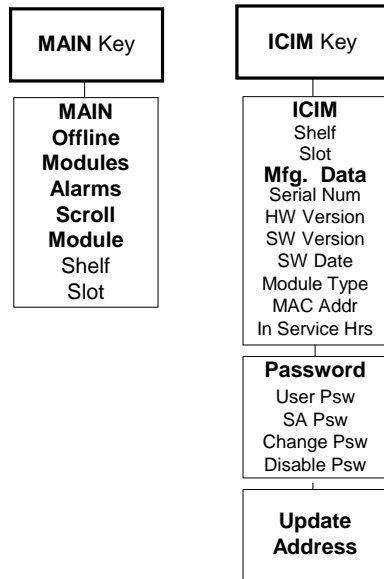

Prisma II Reverse Receiver Software Menu Structure

From the MAIN or SCROLL menus, you can navigate to the Prisma II Reverse Receiver MODULE menu. From the MODULE menu, press the **STAT**, **CFG**, or **ALRM** key to display the desired parameter menu. The structure for the Prisma II Reverse Receiver software is shown below.

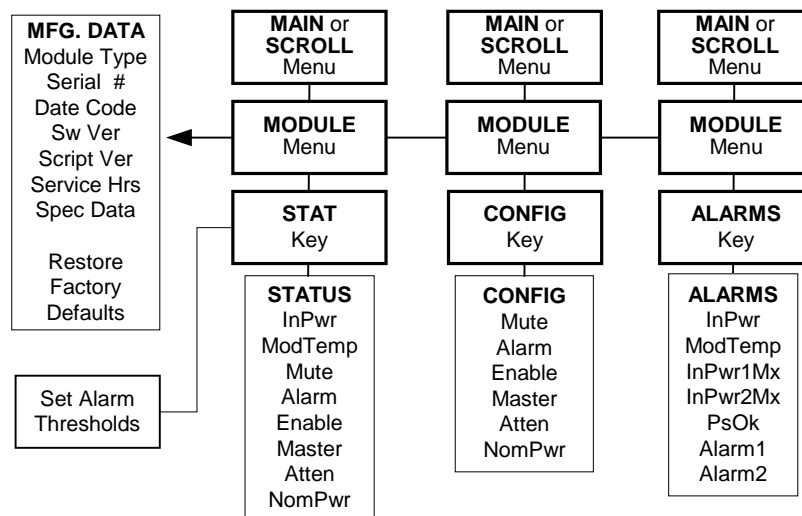

Monitoring Operating Status Using the ICIM













Monitored Parameters

The table below describes the monitored parameters for this module.

Parameter	Function	Operating Range
InPwr1	Displays optical input power for Rx 1	-17.0 dBm to +2.0 dBm
InPwr2	Displays optical input power for Rx 2	-17.0 dBm to +2.0 dBm
ModTemp	Displays module temperature.	-40°C and 65°C
Mute1	Mute status for Rx 1	ON or OFF
Mute2	Mute status for Rx 2	ON or OFF
Alarm 1	Alarm for Rx 1	ON or OFF
Alarm 2	Alarm for Rx 2	ON or OFF
Enable 1	Rx 1 Enabled	ON or OFF
Enable 2	Rx 2 Enabled	ON or OFF
Master 1	Rx 1 Master	ON or OFF
Master 2	Rx 2 Master	ON or OFF
NomPwr1	Nominal input power	-20.0 dbm to 0 dBm
NomPwr2	Nominal input power	-20.0 dbm to 0 dBm

Checking Operating Status

Using the ICIM, you can check the status of all operating parameters of this module. To monitor the module operating parameters, follow these steps.

1. From the MAIN menu, press the  key to highlight **Shelf** and **Slot** fields.
2. Press the  key to address the **Shelf** number. Then press the  key or the  key to scroll to the number of the desired shelf.
3. Press the  key. The **Slot** field is highlighted.
4. Press the  key or the  key to scroll to the number of the desired slot.
5. Press the  key. The information for the module of interest is now displayed on the ICIM menu.
6. When you have reached the desired module's location, press the  key.
7. Press the  key or the  key to scroll through the monitored parameters until you find the parameter of interest.
8. Check the status of the desired parameter or select other parameters to monitor. When finished, press the  key to return to the MAIN menu.

Continued on next page

Monitoring Operating Status Using the ICIM, Continued

STATUS Menus

Press **STAT** to select the **STATUS** menus. Some typical **STATUS** menus are shown below.

STATUS	
Shelf	5
Slot	12
Reverse Data Receiver	
InPwr 1	-26.1 dBm
InPwr 2	-26.1 dBm
▲ ▼	

STATUS	
Shelf	5
Slot	12
Reverse Data Receiver	
ModTemp	36.2 DegC
Mute 1	OFF
▲ ▼	

STATUS	
Shelf	5
Slot	12
Reverse Data Receiver	
Mute 2	OFF
Alarm 1	OFF
▲ ▼	

STATUS	
Shelf	5
Slot	12
Reverse Data Receiver	
Alarm 2	OFF
Enable 1	ON
▲ ▼	

STATUS	
Shelf	5
Slot	12
Reverse Data Receiver	
Enable 2	ON
Master 1	ON
▲ ▼	

STATUS	
Shelf	5
Slot	12
Reverse Data Receiver	
Master 2	ON
Attn 1	0 dB
▲ ▼	

STATUS	
Shelf	5
Slot	12
Reverse Data Receiver	
Attn 2	0 dB
NomPwr 1	0 dBm
▲ ▼	

STATUS	
Shelf	5
Slot	12
Reverse Data Receiver	
NomPwr 2	0 dBm
▲ ▼	

Configuring the Reverse Receiver Using the ICIM

Configurable Parameters

Configurable parameters for the Prisma II Reverse Receiver are listed below.















Control	Function	Values	Default
Mute1, Mute2	Force Mute. Muting of the RF signal and removal of power to the amplifier only if the Enable control is on for this particular side.	ON or OFF	OFF
Enable1, Enable2	Enables or disables unit operation, i.e., muting enabled and no alarm capability	ON or OFF	ON
Alarm1, Alarm2	Force Alarm. Alarm relay is manually overridden only if the Enable control is On. This sets a particular side to alarm as if there was an internal alarm, i.e., Alarm output high, muting on as per Force Mute above	ON or OFF	OFF
Master1, Master2	Configures the module as master or slave. If set to Master, the unit is controlled only by the Enable control above. If set to Slave, the unit is controlled by a combination of the Enable control and the external input CNT_IN_1 or CNT_IN_2.	ON or OFF	ON
Atten1 Atten2	Sets the attenuation level of the output RF signal.	Decimal number between 0 and 20 dB, increments of 0.5 dB	0 dB
NomPwr1, NomPwr2	The nominal input optical power level, in dBm.	Decimal number between -20 and 0 dBm, increments of 0.5 dBm	0 dB

Continued on next page

Configuring the Reverse Receiver Using the ICIM, Continued

Configuring Parameters

Using the ICIM, you can configure the parameters listed above. To configure the parameters, follow these steps. CONFIG parameters are listed before these procedures.

1. From the **MAIN** menu, press the  key to highlight the **Shelf** and **Slot** fields.
2. Press the  key to address the **Shelf** number. Then press the  key or the  key to scroll to the number of the desired shelf.
3. Press the  key. The **Slot** field is highlighted.
4. Press the  key or the  key to scroll to the number of the desired slot.
5. Press the  key. The initial information for the module of interest is now displayed on the ICIM menu.
6. To configure the module, press the  key.
7. Press the  key or the  key to scroll through the configurable controls until you find the parameter of interest.
8. Press the  key to select the highlighted control.
9. Press the  key or the  key to activate or change the value of the selected control.
10. Press the  key to save the changes and return to the MAIN menu.

Continued on next page

Configuring the Reverse Receiver Using the ICIM, Continued

CONFIG Menus

Some typical Prisma II Reverse Receiver CONFIG menus are shown below.

<pre> CONF IG ----- Shelf 5 Slot 16 ----- Reverse Data Receiver ----- Mute1 Mute2 Alarm1 Alarm2 Enable1 ▲ ▼ </pre>	<pre> CONF IG ----- Shelf 5 Slot 16 ----- Reverse Data Receiver ----- Enable2 Master1 Master2 Atten1 Atten2 ▲ ▼ </pre>	<pre> CONF IG ----- Shelf 5 Slot 16 ----- Reverse Data Receiver ----- NomPwr1 NomPwr2 ▲ ▼ </pre>	<pre> CONF IG ----- Shelf 5 Slot 16 ----- Reverse Data Receiver ----- Mute1 OFF ----- Mute2 OFF ▲ ▼ </pre>
<pre> CONF IG ----- Shelf 5 Slot 16 ----- Reverse Data Receiver ----- Alarm1 OFF ----- Alarm2 OFF ▲ ▼ </pre>	<pre> CONF IG ----- Shelf 5 Slot 16 ----- Reverse Data Receiver ----- Enable1 ON ----- Enable2 ON ▲ ▼ </pre>	<pre> CONF IG ----- Shelf 5 Slot 16 ----- Reverse Data Receiver ----- Master1 ON ----- Master2 ON ▲ ▼ </pre>	<pre> CONF IG ----- Shelf 5 Slot 16 ----- Reverse Data Receiver ----- Atten1 0.0 dB ----- Atten2 0.0 dB ▲ ▼ </pre>

Checking Reverse Receiver Alarms Using the ICIM













Checking Alarms

If the red ALARM LED on the front panel is blinking a minor alarm condition is indicated. If the red ALARM LED on the front panel is illuminated, a critical alarm condition is indicated.

Alarms fall into one of the following categories.

- Major low
- Minor low
- Minor high
- Major high

To check alarm conditions follow these steps.

1. From the MAIN menu, press the  key to highlight the **Shelf** and **Slot** fields.
2. Press the  key to address the **Shelf** number. Then press the  key or the  keys to scroll to the number of the desired shelf.
3. Press the  key. The **Slot** field is highlighted.
4. Press the  key or the  key to scroll to the number of the desired slot.
5. Press the  key. The **MODULE** menu is displayed on the ICIM.
6. Press the  key. The module alarm conditions are displayed here.
7. Use the  key or the  key to scroll through alarm conditions until the desired alarm is displayed.
8. Monitor the alarm condition(s). Take appropriate action. Verify that all settings and thresholds relating to the alarm indication are set correctly to rule out an unintended alarm.
9. When finished, press the  key. The display returns to the MAIN menu.

Continued on next page



Checking Reverse Receiver Alarms Using the ICIM, Continued

User Alarm Data Display

The user alarm data for this module is shown below. For additional troubleshooting information, see Chapter 5, **Maintenance and Troubleshooting**.

Alarm	Function	Major Low Limit	Minor Low Limit	Minor High Limit	Major High Limit	Hysteresis	Operating Range
InPwr1	Optical input 1	-20.0	-4.0	2.0	3.2	1	-17.0 to +2.0 dBm
InPwr2	Optical input 2	-20.0	-4.0	2.0	3.2	1	-17.0 to +2 dBm
ModTemp	Module Temp	-125	-85	85	125	1	-40°C and 65°C

User Alarm Menus

After a module's **ALARM** function is selected, press the  key or the  key to scroll through active alarms. Some typical user **ALARMS** screens are shown below.

ALARMS	
Shelf	5
Slot	16
Reverse Data Receiver	
InPwr1	MajL
▲ ▼	

ALARMS	
Shelf	5
Slot	16
Reverse Data Receiver	
InPwr2	MajL
▲ ▼	

ALARMS	
Shelf	5
Slot	16
Reverse Data Receiver	
ModTemp	MinH
▲ ▼	

Continued on next page



Checking Reverse Receiver Alarms Using the ICIM, Continued

Module Alarm Data Display

The module alarm data for this module is shown below. For additional troubleshooting information, see Chapter 5, **Maintenance and Troubleshooting**.

Alarm	Function	Major Low Limit	Minor Low Limit	Minor High Limit	Major High Limit	Operating Range
InPwr1Mx	Maximum optical input power limit	-100	-100	3.2	3.2	N/A
InPwr2Mx	Maximum optical input power limit	-100	-100	3.2	3.2	N/A
PsOk	Bus voltage status	N/A	N/A	N/A	N/A	OK
Alarm1	Manual (forced) alarm	N/A	N/A	N/A	N/A	N/A
Alarm2	Manual (forced) alarm	N/A	N/A	N/A	N/A	N/A

Module Alarm Menus

After the module's **ALARM** function is selected, press the  key or the  key to scroll through active alarms. Some typical module **ALARMS** screens are shown below.

ALARMS	
Shelf	5
Slot	16

Reverse	
Data	
Receiver	

InPwr1Mx	
MajL	
InPwr2Mx	
MajL	
▲ ▼	

ALARMS	
Shelf	5
Slot	16

Reverse	
Data	
Receiver	

PsOk	
MajL	

▲ ▼	

ALARMS	
Shelf	5
Slot	16

Reverse	
Data	
Receiver	

Alarm1	

Alarm2	

▲ ▼	

Checking Reverse Receiver Alarms Using the ICIM, Continued

Setting User Alarm Thresholds

User alarms have adjustable thresholds. To change a user alarm threshold from the factory default, follow the steps below.

1. At the **MODULE** menu, press the **STAT** key. The **STATUS** menu is displayed on the ICIM.
2. Press the **SEL** key. The alarm thresholds previously set are displayed. If the label **n/a** is displayed, you cannot configure that alarm threshold. Press the **▼** key to highlight the next parameter's alarm threshold.
3. When the threshold that you wish to set is highlighted, press the **ENTER** key.
4. Press the **+** key or the **☐** key to adjust the alarm threshold.
5. Press the **ENTER** key to save the changes. **Data Saved** is displayed.
6. When finished, press the **MAIN** key to return to the **MAIN** menu.

Reverse Receiver Alarm Threshold Menus

Some typical alarm threshold menus are shown below.

STATUS	

Shelf	0
Slot	6

Reverse	
Data	
Receiver	

InPwr 1	
MajH3	.200
MinH2	.000
MinL	-4.000
MajL	-20.00

STATUS	

Shelf	0
Slot	6

Reverse	
Data	
Receiver	

InPwr 1Mx	
MajH3	.200
MinH3	.200
MinL	-100.0
MajL	-100.0

STATUS	

Shelf	0
Slot	6

Reverse	
Data	
Receiver	

InPwr 2	
MajH3	.200
MinH2	.000
MinL	-4.000
MajL	-20.00

STATUS	

Shelf	0
Slot	6









Reverse	
Data	
Receiver	

InPwr 2Mx	
MajH3	.200
MinH3	.200
MinL	-100.0
MajL	-100.0

Checking Manufacturing Data Using the ICIM

Checking Manufacturing Data

The Manufacturing Data information listed later can be displayed on the ICIM menu. To access the module's Manufacturing Data, follow these steps.

1. From the MAIN menu, press the  key to highlight the **Shelf** and **Slot** fields.
2. Press the  key to address the **Shelf** number. Then press the  key or the  keys to Scroll to the number of the desired shelf.
3. Press the  key. The **Slot** field is highlighted.
4. Press the  key or the  key to scroll to the number of the desired slot.
5. Press the  key. The **MODULE** menu for this module is selected, as shown on the left below. Press the  key to enter the start of the manufacturing data menu, as shown on the right below.

```



  MODULE
  -----
Shelf   5
Slot   10
  -----
Reverse
  Data
Receiver
  -----
Alarms
  1
  -----
Mfg . Data
  ▲ ▼

```

```

  MFG . DATA
  -----
Shelf   5
Slot   10
  -----
Reverse
  Data
Receiver
  -----
Module
  Type
  2000
  ▲ ▼

```

6. The  or  keys allow you to scroll through the manufacturing data.

Continued on next page



Checking Manufacturing Data Using the ICIM, Continued

Manufacturing Data Display

The table below describes the manufacturing data available for this module.

Manufacturing Data	Typical Values
Module	Reverse Data Receiver
Module Type	2000
Serial #	!ABCDEFGG
Date Code	L00
Sw Ver (Software Version)	CCB607
Script Ver (Script Version)	33
In Service Hours	1
Spec data	Special data
Restore Factory Defaults	Restores the module's factory default configuration settings.

MFG. DATA Menus

When the **MFG. DATA** menu is selected, the  key or the  key allows you to scroll through the manufacturing parameters specific to this module. Some typical **MFG. DATA** menus are shown below.

MFG . DATA ----- Shelf 5 Slot 10 ----- Reverse Data Receiver ----- Module Type 2000 ▲ ▼	MFG . DATA ----- Shelf 5 Slot 10 ----- Reverse Data Receiver ----- Serial # AAYCUA Date Code L00 ▲ ▼	MFG . DATA ----- Shelf 5 Slot 10 ----- Reverse Data Receiver ----- Sw Ver ccb606 Script Ver 33 ▲ ▼	MFG . DATA ----- Shelf 5 Slot 10 ----- Reverse Data Receiver ----- In Service Hours 1 ▲ ▼
--	--	--	--

Continued on next page

Checking Manufacturing Data Using the ICIM, Continued

MFG . DATA	
Shelf	5
Slot	10
Reverse Data Receiver	
Spec Data	
▲ ▼	

MFG . DATA	
Shelf	5
Slot	10
Reverse Data Receiver	
Restore Factory Defaults	

Using the ICIM to Save the Configuration

Saving the Current Configuration

To save the current module configuration, follow these steps after every change.

1. After you have changed a parameter or entered data, press the **ENTER** key to save the changes and return to the MAIN menu.
2. If you do not save your changes for two minutes, or if you press the **SHIFT** **CAN** keys at the same time, changes are aborted and the display returns to the MAIN menu.

Configuration Complete

Once you have configured the module using the ICIM to your system's specifications, and no alarms are indicated, no further action is necessary. The module operates without further input. Alarms, changes in operating parameters, electrical power fluctuations, or changes in system design may be cause for additional action.

Chapter 4

Operation Using LCI

Overview

Introduction

The installation steps and procedures in this chapter apply if you are using the Local Craft Interface (LCI) to configure and operate the Prisma II Reverse Data Receiver and the Prisma II Reverse Video Receiver. All instructions are identical for both products.

Scope of this Chapter

Included in this chapter are LCI installation instructions and detailed descriptions of how to use LCI to configure and view information for the reverse receivers.

In This Chapter

This chapter contains the following topics.

Topic	See Page
LCI Introduction	4-3
System Requirements	4-4
Installing LCI	4-5
Connecting Your Laptop Computer to the Chassis	4-9
Starting LCI	4-10
LCI Module Tree Overview	4-11
Accessing the Module Details Window	4-13

Overview, Continued

Topic	See Page
Checking the Operating Status	4-20
Configuring the Reverse Receiver	4-22
Checking Reverse Receiver Alarms	4-25
Modifying Reverse Receiver Alarm Limits	4-27
Checking Manufacturing Data	4-30



WARNING:

Avoid damage to your eyes! Do not look into any optical connector while the system is active. Even if the unit is off, there may still be hazardous optical levels present.

LCI Introduction

LCI Function

LCI is software that functions as a user interface for the Prisma II platform. LCI is installed on a laptop computer, which is then connected to a Prisma II Chassis. Using LCI, you can configure and monitor the modules in the chassis the computer is connected to.

Important: Do not operate any Prisma II Chassis without a fan tray installed. If a fan tray is not installed in the Prisma II Chassis, the LCI will not communicate with the power supplies in that chassis.

System Requirements

Introduction

You will need the following computer software and hardware to run LCI.

Laptop Computer Requirements

- Pentium II® 300 MHz processor or equivalent
- 128 MB RAM
- 10 MB available hard drive space
- 1.44 MB floppy drive
- CD-ROM Drive
- Windows® 95 or later operating system software

Connecting the PC to the Prisma II Chassis

The required cable is a standard “off the shelf” DB9 Female to DB9 Male serial extension cable. The connectors are a serial 9-pin D-shell (EIA 574/232).

The Cisco part number for a six-foot DB9 Female to DB9 Male extension cable is 180143.

Installing LCI

Introduction

This section describes how to install your LCI software.

Installing the LCI Software

To install LCI, follow these steps.

1. Close all programs that are running on your computer.
2. Insert the LCI CD-ROM into your CD-ROM drive.

Result: The LCI Installation program starts automatically.

3. Click **Next**.

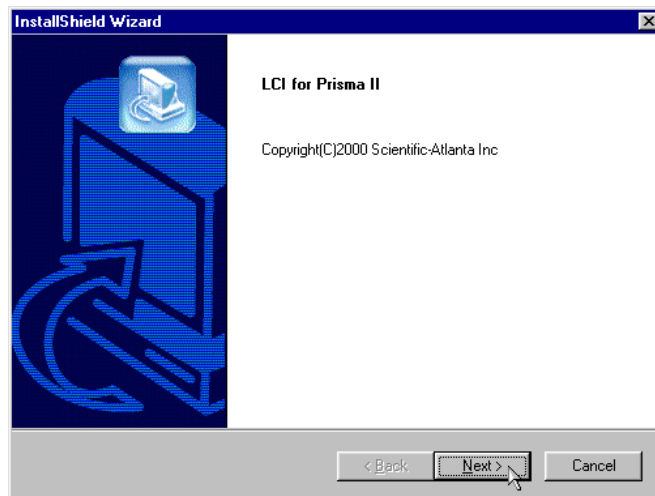

Result: The License Agreement screen displays.

Installing LCI, Continued

4. Click **Yes** to accept the license agreement.

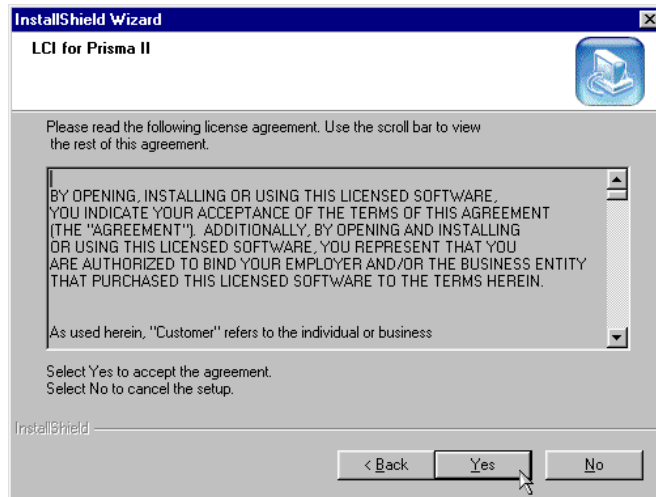

Result: The License Agreement Confirmation dialog box displays.

5. Click **Yes**.

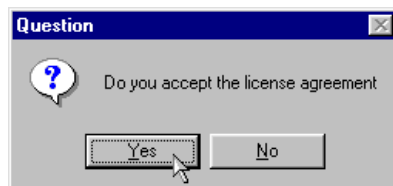

Result: The Destination Folder screen displays.

Installing LCI, Continued

6. Do you want to install LCI in the specified folder?
 - If **yes**, click **Next** to begin the installation, and go to step 10.
 - If **no**, click **Browse**, and go to step 7.

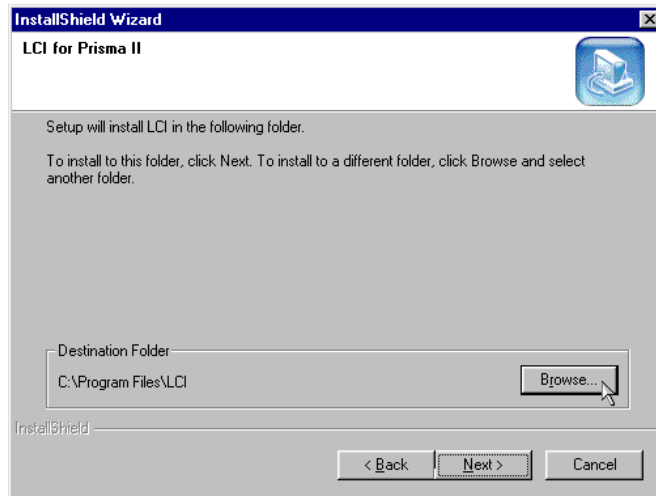

7. To specify where you want LCI to be installed, type the path in the **Path** box, or select it in the **Directories** box.

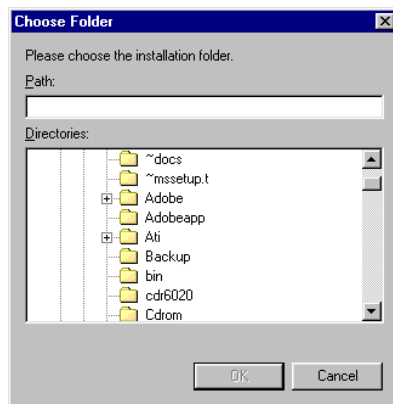

8. Click **OK**.
Result: The Destination Folder screen displays.
9. Click **Next** to begin the installation.
Result: The last installation wizard screen displays after the installation is complete.

Installing LCI, Continued

10. Click **Finish**.

Note: You have the option to select the **Do not display LCI for Prisma II information** check box. This bypasses the registration card that you can fill out to receive product updates.

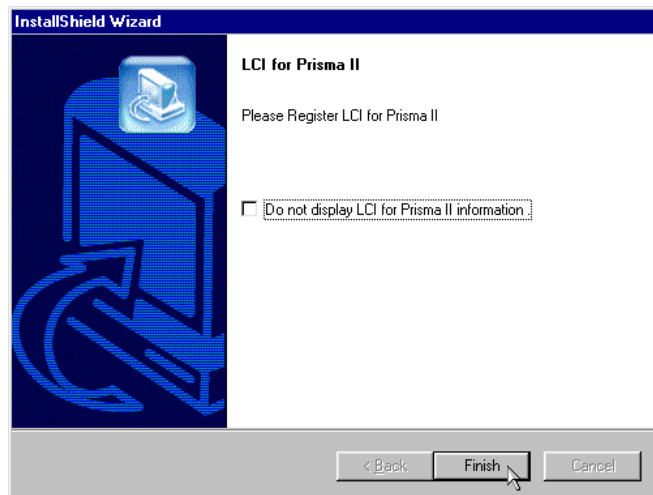

Result: LCI is installed, and the Registration Information file displays.

11. Follow the instructions in the file.

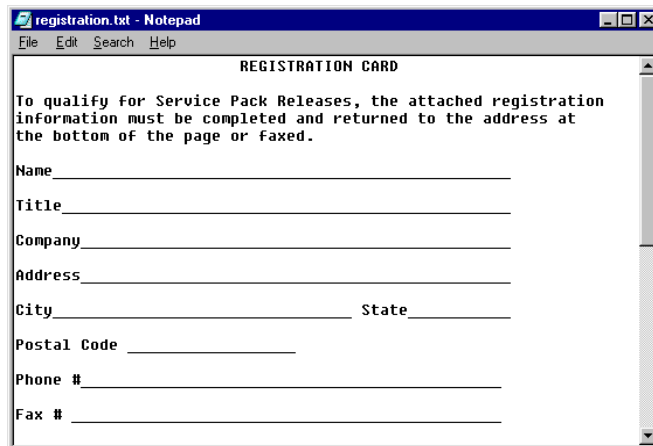

Connecting Your Laptop Computer to the Chassis

Introduction

Before you start LCI, you must first connect your laptop computer to the chassis that contains the module(s) you want to check.

Important: LCI communicates only with those modules located in the chassis your computer is attached to. To check other modules, you must connect your computer to the chassis they are located in.

Connecting to the Chassis

To connect your laptop to the chassis, follow these steps.

1. Plug one end of a nine-pin serial extension cable into your computer.
2. Plug the other end of the cable into the LCI port. This port is labeled “Local Craft Interface”.

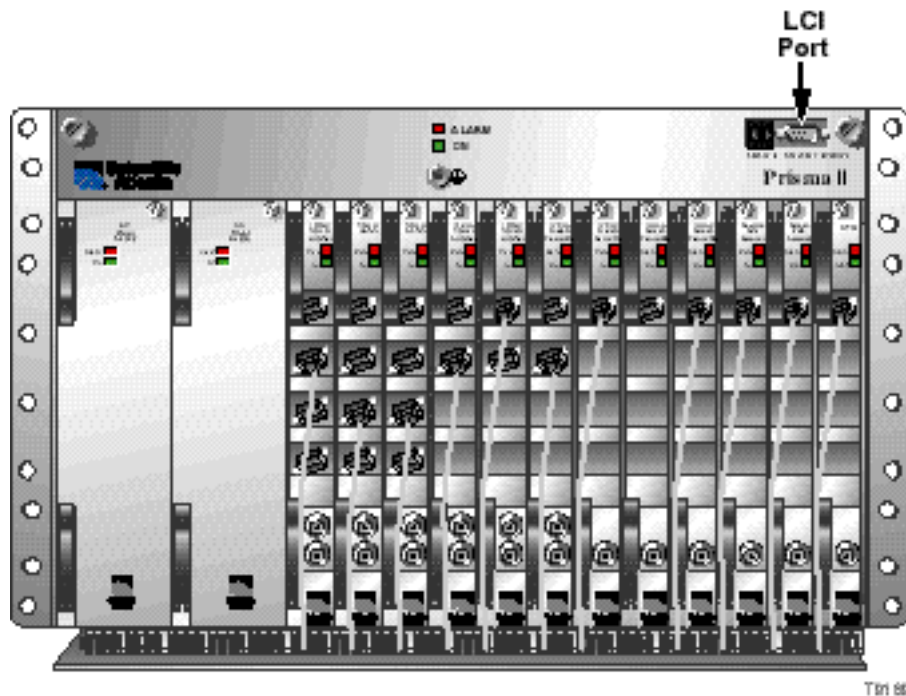

Starting LCI

Introduction

When LCI is started, it polls the module(s) located in the chassis your computer is attached to. For each module it finds, LCI does the following:

- Represents the module in the module tree of the main LCI window
- Makes the polling information available so you can check and configure various parameters

Important: Your computer must be connected to the chassis before you start LCI. For instructions, refer to **Connecting Your Laptop Computer to the Chassis** earlier in this chapter.

Starting LCI

To start the software, double-click the LCI icon on your Windows desktop.



Results:

- LCI polls the modules in the chassis
- The main LCI window displays

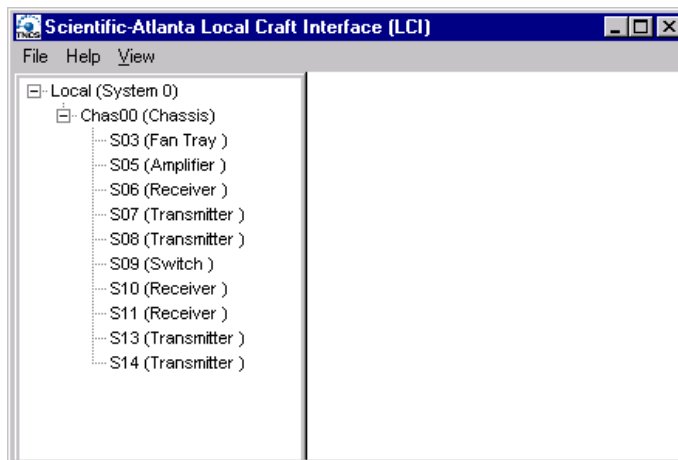

LCI Module Tree Overview

Introduction

The main window of LCI contains a tree that represents your system in a hierarchical manner.

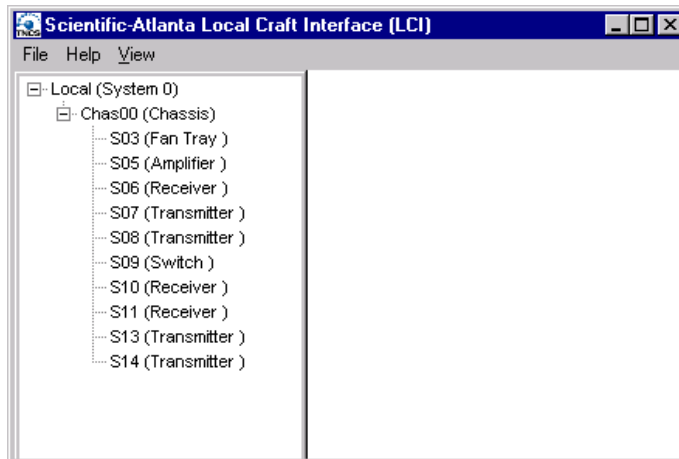

Module Tree

In the graphic above, the module tree represents a laptop connected to a chassis that contains ten modules. The three tree levels are described in the following table.

Module Tree Level	Description
Local (System 0)	Laptop computer being used
Chass00 (Chassis)	Chassis the computer is connected to
Sxx (Module name)	Module(s) located within the chassis. Each module is of the format <i>chassis slot location (module name)</i> . Example: In the graphic above, S11 (Receiver) represents a receiver that's located in slot 11 of the chassis.

LCI Module Tree Overview, Continued

Module Information

Information about a module (its parameters, alarms and statuses) is located in the Module Details window. Within the module tree, you can access this window using one of the following four methods:

- Double-click the chassis and select the module in the graphic that displays
- Right-click the chassis and select **Open** from the menu that displays
- Double-click the module
- Right-click the module and select **Details** from the menu that displays

Note: Although you can use the method that's most convenient for you, the procedures throughout this chapter are described using the right-click module technique.

For more information about each of these methods, refer to the next section, **Accessing the Module Details Window**.

Accessing the Module Details Window

Introduction

Information about a module (its parameters, alarms and statuses) is located in the Module Details window. The graphic below shows the Module Details window for a Prisma II Reverse Data Receiver.

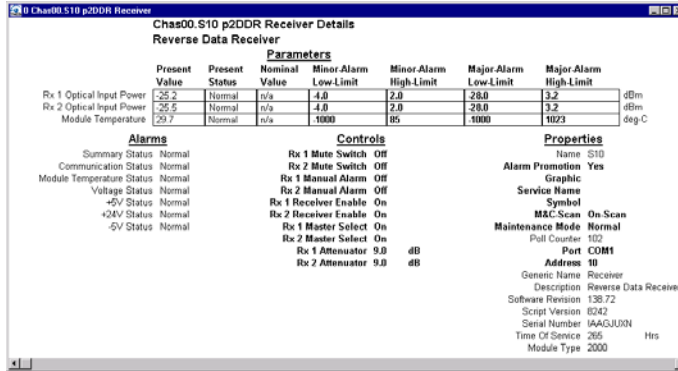

Within LCI's module tree, you can access this window using one of the following four methods:

- Double-click the chassis and select the module in the graphic that displays
- Right-click the chassis and select **Open** from the menu that displays
- Double-click the module
- Right-click the module and select **Details** from the menu that displays

Note: Although you can use the method that's most convenient for you, the procedures throughout this chapter are described using the right-click module technique.

For more information about the module tree, refer to **LCI Module Tree Overview** earlier in this chapter.

Accessing the Module Details Window, Continued

Double-Click the Chassis

To access the Module Details window, follow these steps.

1. Double-click the chassis.

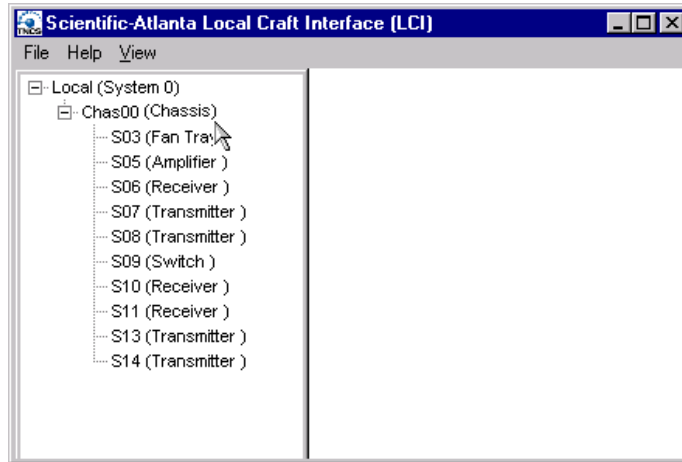

Result: A graphic representation of the chassis displays.

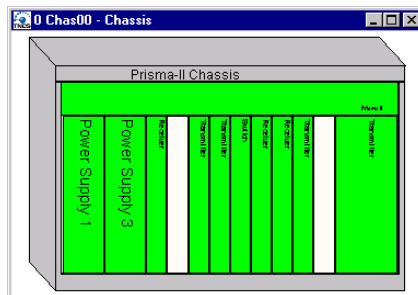

Accessing the Module Details Window, Continued

- Double-click the module whose information you want to view and/or configure.

Result: The Module Details window displays.

The screenshot shows a window titled "Chas00.S10 p2DDR Receiver" with a sub-header "Reverse Data Receiver". The window is divided into several sections:

Parameters							
Present Value	Present Status	Nominal Value	Minor Alarm Low-Limit	Minor Alarm High-Limit	Major Alarm Low-Limit	Major Alarm High-Limit	
Rx 1 Optical Input Power	-25.2	Normal	n/a	4.0	2.0	28.0	3.2 dBm
Rx 2 Optical Input Power	-25.6	Normal	n/a	4.0	2.0	28.0	3.2 dBm
Module Temperature	29.7	Normal	n/a	1000	85	1000	1023 deg.C

Alarms

- Summary Status: Normal
- Communication Status: Normal
- Module Temperature Status: Normal
- Voltage Status: Normal
- +24V Status: Normal
- 5V Status: Normal

Controls

- Rx 1 Mute Switch: Off
- Rx 2 Mute Switch: Off
- Rx 1 Manual Alarm: Off
- Rx 2 Manual Alarm: Off
- Rx 1 Receiver Enable: On
- Rx 2 Receiver Enable: On
- Rx 1 Master Select: On
- Rx 2 Master Select: On
- Rx 1 Attenuator: 9.0 dB
- Rx 2 Attenuator: 9.0 dB

Properties

- Name: S10
- Alarm Promotion: Yes
- Graphic: Service Name
- Symbol: MAC Scan
- On-Scan: Maintenance Mode
- Normal: Port Counter: 102
- Port: COM1
- Address: 10
- Generic Name: Receiver
- Description: Reverse Data Receiver
- Software Revision: 138.72
- Script Version: 6042
- Serial Number: IAAGJUN
- Time Of Service: 265 Hrs
- Module Type: 2000

- Proceed with viewing and/or configuring information.

Accessing the Module Details Window, Continued

Right-Click the Chassis

To access the Module Details window, perform these steps.

1. Right-click the chassis, and click **Open**.

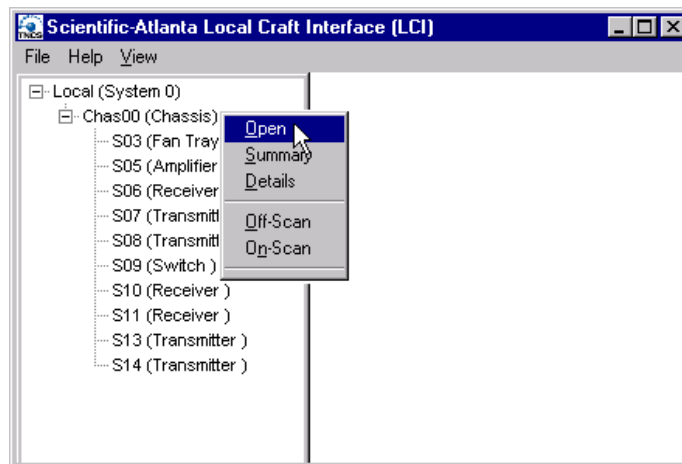

Result: A graphic representation of the chassis displays.

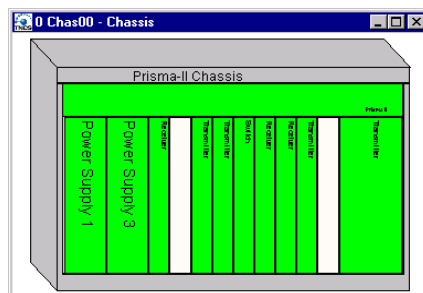

Accessing the Module Details Window, Continued

- Double-click the module whose information you want to view and/or configure.

Result: The Module Details window displays.

The screenshot shows a window titled "Chas00.S10 p2DDR Receiver" with a sub-header "Reverse Data Receiver". The window is divided into several sections:

Parameters							
Present Value	Present Status	Nominal Value	Minor Alarm Low-Limit	Minor Alarm High-Limit	Major Alarm Low-Limit	Major Alarm High-Limit	
Rx 1 Optical Input Power	-25.2	Normal	n/a	4.0	2.0	28.0	3.2 dBm
Rx 2 Optical Input Power	-25.6	Normal	n/a	4.0	2.0	28.0	3.2 dBm
Module Temperature	29.7	Normal	n/a	1000	85	1000	1023 deg.C

Alarms

- Summary Status: Normal
- Communication Status: Normal
- Module Temperature Status: Normal
- Voltage Status: Normal
- +24V Status: Normal
- 5V Status: Normal

Controls

- Rx 1 Mute Switch: Off
- Rx 2 Mute Switch: Off
- Rx 1 Manual Alarm: Off
- Rx 2 Manual Alarm: Off
- Rx 1 Receiver Enable: On
- Rx 2 Receiver Enable: On
- Rx 1 Master Select: On
- Rx 2 Master Select: On
- Rx 1 Attenuator: 9.0 dB
- Rx 2 Attenuator: 9.0 dB

Properties

- Name: S10
- Alarm Promotion: Yes
- Graphic: Service Name
- Symbol: MAC Scan
- On-Scan: Maintenance Mode
- Normal: Port Counter: 102
- Port: COM1
- Address: 10
- Generic Name: Receiver
- Description: Reverse Data Receiver
- Software Revision: 138.72
- Script Version: 6042
- Serial Number: IAAGJUN
- Time Of Service: 265 Hrs
- Module Type: 2000

- Proceed with viewing and/or configuring information.

Accessing the Module Details Window, Continued

Double-Click the Module

To access the Module Details window, perform these steps.

1. Double-click the module.

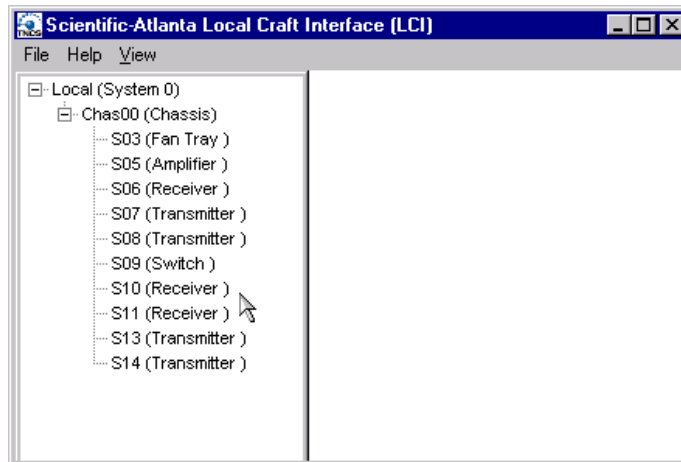

Result: The Module Details window displays.

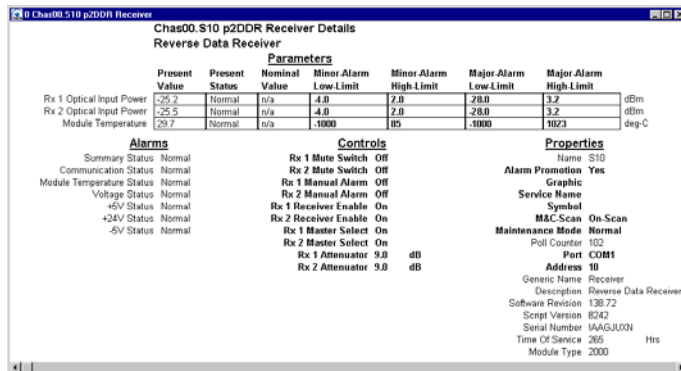

2. Proceed with viewing and/or configuring information.

Accessing the Module Details Window, Continued

Right-Click the Module

To access the Module Details window, perform these steps.

1. Right-click the module, and click **Details**.

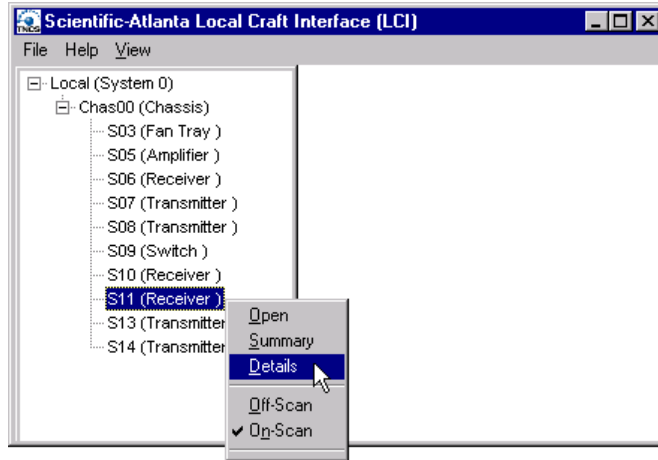

Result: The Module Details window displays.

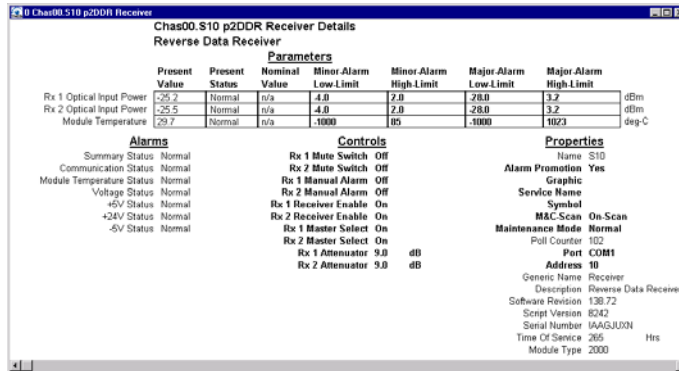

2. Proceed with viewing and/or configuring information.

Checking the Operating Status

Introduction

Using LCI, you can check the status of all operating parameters of the Prisma II Reverse Receiver.

Monitored Parameters

The table below describes the monitored parameters for this module.

Parameter	Function	Operating Range
Rx 1 Optical Input Power	Displays optical input power for Rx 1	-17.0 dBm to +2.0 dBm
Rx 2 Optical Input Power	Displays optical input power for Rx 2	-17 dBm to +2 dBm
Module Temperature	Displays module temperature	-40°C and 65°C

Checking the Operating Status, Continued

Checking the Operating Status

To monitor the module operating parameters, follow these steps.

1. In the module tree, right-click one of the Prisma II Reverse Receivers, and click **Details**.

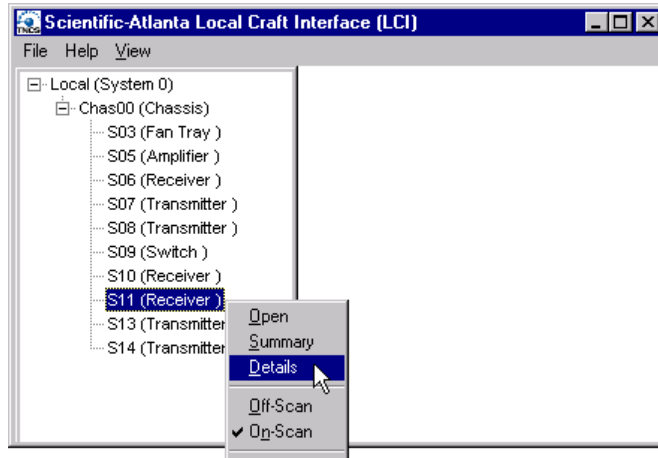

Result: The Module Details window displays. The monitored parameters are displayed under **Parameters**.

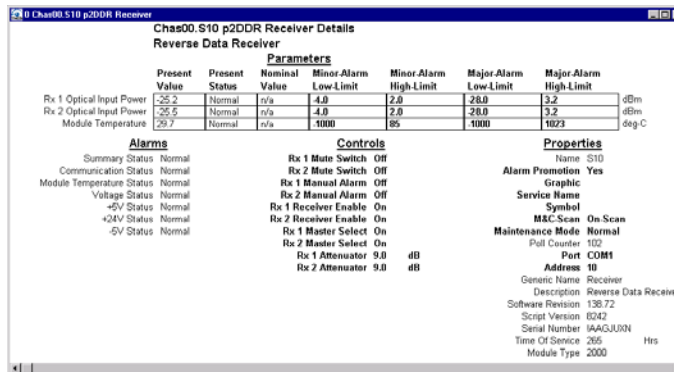

2. Proceed with checking the operating parameters.

Configuring the Reverse Receiver

Introduction

Using LCI, you can configure the parameters listed below.

Configurable Parameters

Configurable parameters for the Prisma II Reverse Receiver are listed below.

Control	Function	Values	Default
Rx 1 Mute Switch, Rx 2 Mute Switch	Force Mute. Muting of the RF signal and removal of power to the amplifier only if the Enable control is on for this particular side.	On = Mute On Off = Mute Off	Off
Rx 1 Receiver Enable, Rx2 Receiver Enable	Enables or disables unit operation, i.e., muting enabled and no alarm capability.	On = Enabled Off = Disabled	On
Rx 1 Manual Alarm Rx 2 Manual Alarm	Force Alarm. Alarm relay is manually overridden only if the Enable control is On. This sets a particular side to alarm as if there was an internal alarm, i.e., Alarm output high, muting on as per Force Mute above	On = Alarm On Off = Alarm Off	Off
Rx 1 Master Select Rx 2 Master Select	Configures the module as master or slave. If set to Master, the unit is controlled only by the Enable control above. If set to Slave, the unit is controlled by a combination of the Enable control and the external input CNT_IN_1 or CNT_IN_2.	On = Master On Off = Slave On	On
Rx 1 Attenuator Rx 2 Attenuator	Sets the attenuation level of the output RF signal.	Decimal number between 0 and 20 dB, increments of 0.5 dB	0

Configuring the Reverse Receiver, Continued

Configuring Parameters

To configure the parameters, follow these steps.

1. In the module tree, right-click one of the Prisma II Reverse Receivers, and click **Details**.

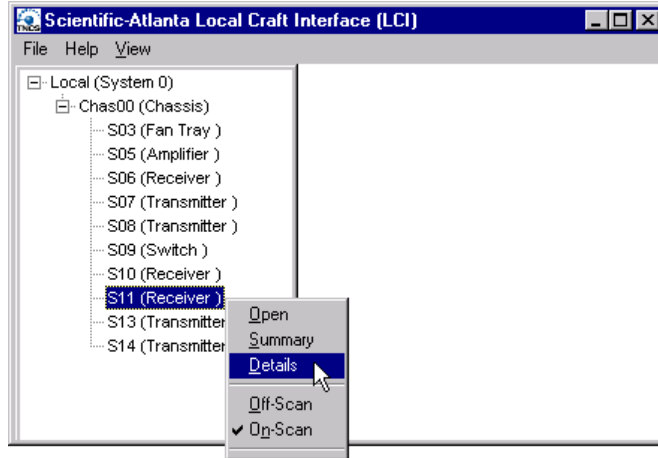

Result: The Module Details window displays.

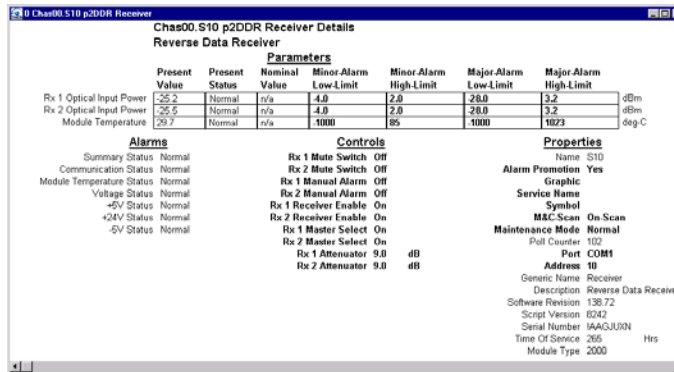

Configuring the Reverse Receiver, Continued

2. Under **Controls**, double-click the parameter you want to configure.

Result: The Change Value dialog box displays. The graphic below shows the dialog box for the Rx 1 Mute Switch parameter.

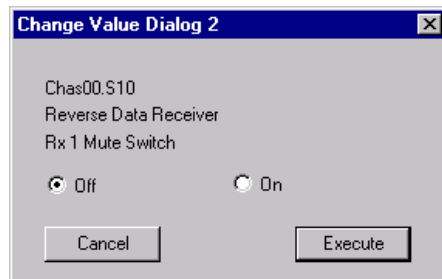

3. Depending on the parameter you chose, select or type a new value.
4. Click **Execute**.

Result: The new value displays next to the parameter.

Checking Reverse Receiver Alarms

Introduction

Using LCI, you can check the alarm status of various parameters. Alarms that you can check are listed below.

Alarm	Function	Major Low Limit	Minor Low Limit	Minor High Limit	Major High Limit	Hysteresis	Operating Range
Rx 1 Optical Input Power	Optical input 1	-20	-4	2	3.2	1	-17.0 to +2.0 dBm
Rx 2 Optical Input Power	Optical input 2	-20	-4	2	3.2	1	-17.0 to +2 dBm
Module Temperature	Module Temp	-125	-85	85	125	1	-40°C and 65°C

Alarms limits fall into one of the following categories.

- Major low
- Minor low
- Minor high
- Major high

Checking Reverse Receiver Alarms, Continued

Checking Alarms

To check a parameter's alarm status, perform these steps.

1. Right-click one of the Prisma II Reverse Receivers, and click **Details**.

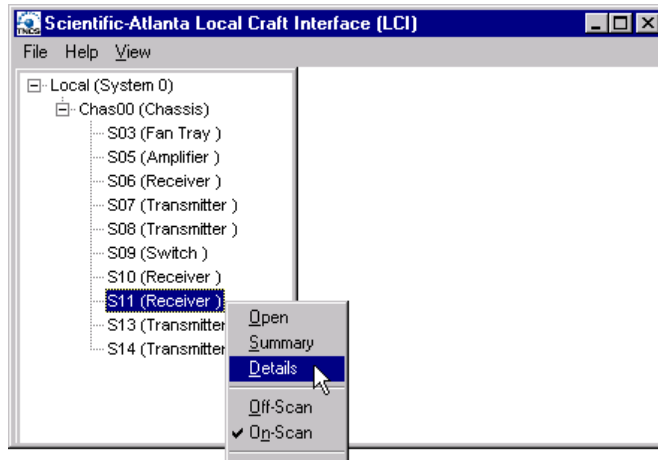

Result: The Module Details window displays. The alarms are shown under **Alarms**.

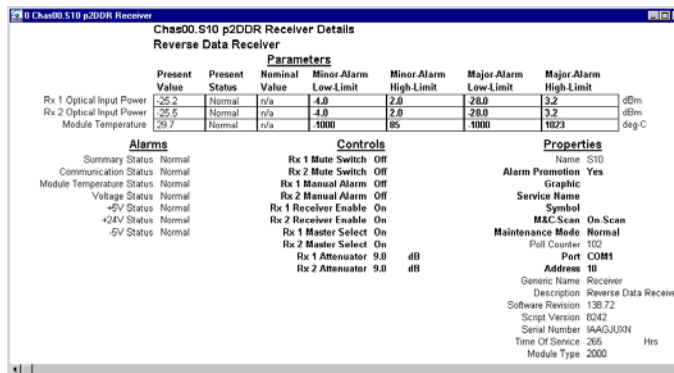

2. If any of the parameters are in alarm, take the corrective action you deem necessary.

Modifying Reverse Receiver Alarm Limits

Introduction

Using LCI, you can modify alarm limits for several parameters. Parameters whose alarm limits you can change are listed below.

Alarm	Function	Major Low Limit	Minor Low Limit	Minor High Limit	Major High Limit	Hysteresis	Operating Range
Rx 1 Optical Input Power	Optical input 1	-20	-4	2	3.2	1	-17.0 to +2.0 dBm
Rx 2 Optical Input Power	Optical input 2	-20	-4	2	3.2	1	-17.0 to +2 dBm
Module Temperature	Module Temp	-125	-85	85	125	1	-40°C and 65°C

Modifying Reverse Receiver Alarm Limits, Continued

Modifying Alarm Limits

To modify a parameter's alarm limit, follow these steps.

1. In the module tree, right-click one of the Prisma II Reverse Receivers, and click **Details**.

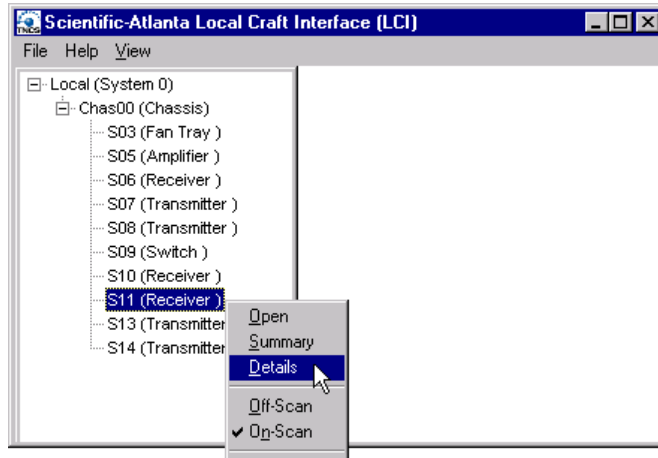

Result: The Module Details window displays. The alarm limits are shown under **Parameters**.

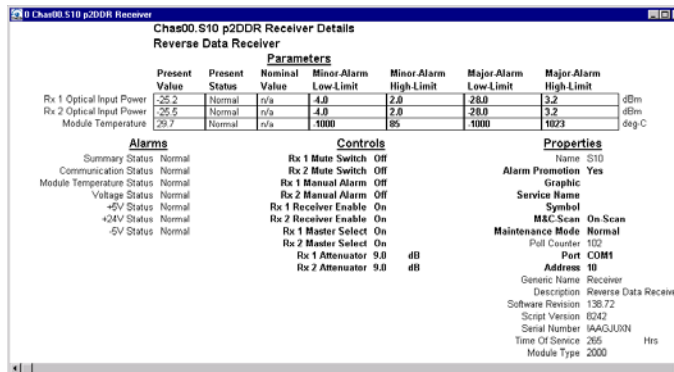

Modifying Reverse Receiver Alarm Limits, Continued

2. Double-click the limit you want to change.

Result: The Change Value dialog box displays. The graphic below shows the dialog box for the minor low limit of the Rx 1 Optical Input Power parameter.

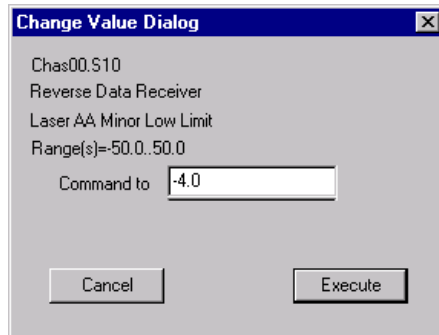

3. In the **Command to** box, type the value to use for the limit.
4. Click **Execute**.

Result: The new value displays in the alarm limit column.

Checking Manufacturing Data

Introduction

Using LCI, you can check the manufacturing data of the reverse receiver.

Manufacturing Data

The table below describes the manufacturing data available for this module.

Manufacturing Data	Typical Values
Description	Reverse Receiver
Module Type	2001
Serial number	012345
Software Revision	6.05
Script Version	28
Time of Service	1

Checking Manufacturing Data, Continued

Checking Manufacturing Data

To access the module's manufacturing data, perform these steps.

1. In the module tree, right-click one of the Prisma II Reverse Receivers, and click **Details**.

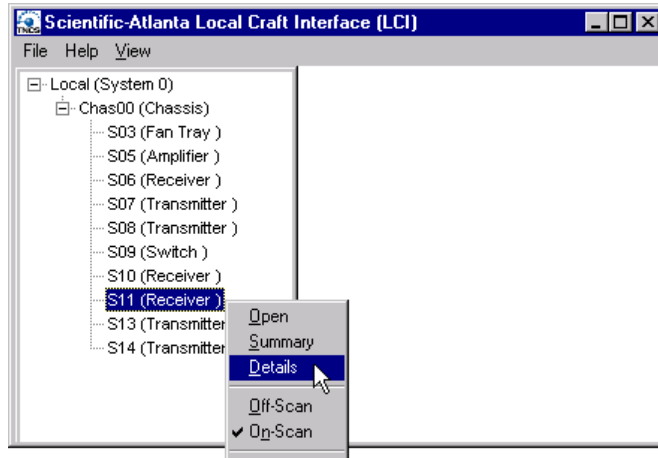

Result: The Module Details window displays. The manufacturing data is displayed under **Properties**.

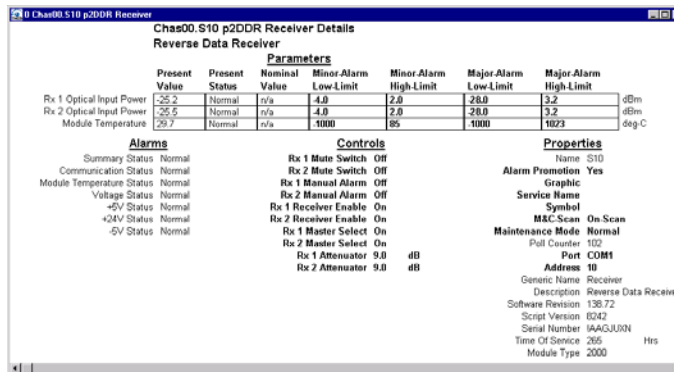

2. Proceed with viewing the manufacturing data.

Chapter 5

Maintenance and Troubleshooting

Overview

Introduction

This chapter provides information to assist you in maintaining and troubleshooting Prisma II Reverse Receiver.

Qualified Personnel

Only appropriately qualified and trained personnel should attempt to troubleshoot this product.



WARNING:

Allow only qualified personnel to install, operate, maintain, or service this product. Otherwise, personal injury or equipment damage may occur.

In This Chapter

This chapter contains the following topics.

Topic	See Page
Module Maintenance	5-2
General Troubleshooting Information	5-3
Troubleshooting Alarm Conditions	5-4

Module Maintenance

Maintaining the Prisma Module

To ensure optimal performance, the following maintenance is recommended.

Frequency	Maintenance Required
Weekly	<ul style="list-style-type: none">• Check all parameters and test points• Record data• Make adjustments as needed
Quarterly	<ul style="list-style-type: none">• Make sure all cables are mated properly• Inspect cables for stress and chafing• Make sure all retaining screws are tight
When needed	Carefully clean the module with a soft cloth that is dampened with mild detergent

Maintenance Record

It may be helpful to establish a maintenance record or log for this module. You may want to record optical input level, RF output readings, frame error status, or power supply voltages.

Large variations in any of the parameters above should be investigated prior to failure.

General Troubleshooting Information

Introduction

This troubleshooting information describes the most common alarms and gives typical symptoms, causes, and items to check before consulting Cisco.

Equipment Needed

You may need the following equipment to troubleshoot the chassis.

- Digital voltmeter
- Fiber connector cleaning materials

Additional Assistance

If you need additional assistance, telephone one of our Technical Service Centers or your local sales subsidiary. The Customer Support section in Chapter 6 contains a list of telephone numbers.

Troubleshooting



WARNING:

Avoid electric shock and damage to this product! Do not open the enclosure of this product. There are no user-serviceable parts inside. Refer servicing to qualified service personnel.

Refer to the following section, **Troubleshooting Alarm Conditions**, to identify and correct receiver faults.

Troubleshooting Alarm Conditions

Alarm Conditions

If the red ALARM indicator is illuminated or is blinking, check the display on the front panel to determine the cause of the alarm.

Alarm	Function	Possible Causes	Possible Solutions
PIndBm1	Optical input 1	Broken fiber	Check fiber
PIndBm2	Optical input 2	Transmitter failure	Check Transmitter
TempC	Module Temperature	Ambient temperature is too high due to: <ul style="list-style-type: none"> • Air conditioner malfunction. 	Diagnose the problem and repair or replace as needed.
		<ul style="list-style-type: none"> • Airflow through the rack restricted or cut off. 	Ensure the airflow system has not been damaged or removed. Repair or replace as needed.
		<ul style="list-style-type: none"> • Fan Tray cooling fans are not operating properly. 	Troubleshoot the fans. Telephone Cisco Services for help.
PsOk	Bus voltage status	Power supply faulty	Check power supply

Chapter 6

Customer Information

If You Have Questions

If you have technical questions, call Cisco Services for assistance. Follow the menu options to speak with a service engineer.

Access your company's extranet site to view or order additional technical publications. For accessing instructions, contact the representative who handles your account. Check your extranet site often as the information is updated frequently.

Glossary

Term, Acronym, Abbreviation	Meaning
A	Ampere (amp) is the unit of measure for electrical current.
AC	Alternating current
Addressable	The ability to control an individual unit in a system of many similar units.
AFC	Automatic Frequency Control
AGC	Automatic Gain Control
AM	Amplitude Modulation
Amplifier Cascade	Two or more amplifiers in a series, the output of one feeding the input of another.
ATC	Automotive fuse
Attenuation	A decrease in signal magnitude occurring in transmission from one point to another or in passing through a loss medium.
Attenuator	A device designed to reduce signal strength by an amount specified in dB.
ATX	Addressable transmitter
AUX	Auxiliary
Baseband	The total signal before it is modified for transmission or otherwise manipulated.
Baud (Bd)	A measure of signaling rate based on the number of signaling events per unit of time
bdr™	Baseband digital reverse
Beamwidth	The included angle between two rays (usually the half-power points) on the radiation pattern, which includes the maximum lobe, of an antenna.
BER	Bit error rate

Glossary, Continued

BERT	Bit error rate test
BIG	Broadband Integrated Gateway
BIOS	Basic Input/Output System
BIST	Built-in self-test
Bit	Short for Binary Digit. Can be either a "one" or a "zero."
Blanking level	The amplitude of the front and back porches of the composite video signal.
BNC	A coaxial connector that uses a bayonet type attachment to secure the cable. It is also known as Baby N connector.
BPF	Bandpass filter
bps	Bits per second - The total number of bits sent in a second of time.
BPSK	Binary Phase Shift Keying
BW	Bandwidth
Byte	A group of bits treated as a unit
CF	Continuous feed
Circuit switching	The type of signal switching traditionally used by telephone companies to create a physical connection between a caller and a called party.
CIRD	Commercial Integrated Receiver Decoder
CIM	Communications Interface Module
CISC	Complex Instruction Set Computer. A computer that uses many different types of instructions to conduct its operations, i.e., IBM PCs, Apple Macintosh's, IBM 370 mainframes.
CIU	Customer Interface Unit
C/N or CNR	Carrier-to-noise ratio

Glossary, Continued

Compression	The non-linear change of gain at one level of a signal with respect to the change of gain at another level for the same signal. Also, the elimination of redundant information from an audio, data, or video signal to reduce transmission requirements.
CSO	Composite Second Order
CTB	Composite Triple Beat
C/T	Carrier-to-noise temperature ratio
CW	Continuous Wave
dB	Decibel
dBc	Decibels relative to a reference carrier
DBDS	Digital Broadband Delivery System
dBm	Decibels relative to 1 milliwatt
dB_i	Decibels of gain relative to an isotropic radiator
dBuV	Decibels relative to 1 microvolt
dBW	Decibels relative to 1 watt
dBmV	Decibels relative to 1 millivolt
DC	Direct current
DC	Directional coupler
DES	Data Encryption Standard
Deviation	The peak difference between the instantaneous frequency of the modulated wave and the carrier frequency, in an FM system.
DFB	Distributed feed back laser
Differential gain	The difference in amplification of a signal (superimposed on a carrier) between two different levels of carrier.
Diplex filter	A filter which divides the frequency spectrum into a high frequency segment and a low frequency segment so that two different signals can be sent down the same transmission path.

Glossary, Continued

Distribution System	Part of a cable system consisting of trunk and feeder cables used to carry signals from headend to subscriber terminals.
Downconverter	A device that converts an input signal to a lower frequency output signal.
Down link	A transmission path carrying information from a satellite or spacecraft to earth.
DP	Data processing
DPU	Digital processing unit
DSP	Digital signal processor
DSR	Digital Storage and Retrieval System
D to U	Desired to undesired signal ratio
DTMF	Dual Tone Multiple Frequency
Duplexer	A device which permits the connection of both a receiver and a transmitter to a common antenna.
DVM	Digital voltmeter
DWDM	Dense Wave Division Multiplexing
ECM	Entitlement Control Message
EDFA	Erbium Doped Fiber Amplifier
EEPROM	Electrically Erasable Programmable Read-Only Memory
EIA	Electronics Industry Association
EMI	Electromagnetic interference
Emission designer	An FCC or CCIR code that defines the format of radiation from a transmitter.
EPROM	Erasable Programmable Read-Only Memory
EQ	Equalizer
Equalization	The process of compensating for an undesired result. For example, equalizing tilt in a distribution system.
ERP	Effective radiated power

Glossary, Continued

FAOC	Frequency agile output converters
FET	Field-effect transistor
FIFO	First in, first out
FM	Frequency modulation
Forward path	Signal direction from the headend to the set-top terminal.
FP	Fabry-Perot laser
Fiber	A single strand of glass used as an optical transmission medium; or a bundle of glass strands in a CATV system.
Frequency	The number of similar shapes in a unit of time. For example, the number of sine waves moving past a fixed point in a second.
Frequency Agile	The ability to change from one frequency to another without changing components.
Frequency Modulation	A system of modulation where the instantaneous radio frequency of the carrier varies in proportion to the instantaneous amplitude of the modulating signal while the amplitude of the radio frequency carrier is independent of the amplitude of the modulating signal.
Frequency Response	The effect that changing the frequency has on the magnitude of a signal.
Frequency Reuse	A technique in which independent information is transmitted on orthogonal polarizations to "reuse" a given band of frequencies.
Frequency Stability	A measure of the departure from nominal frequency value of a signal, with respect to time, temperature, or other influence.
FSM	Field strength meter
FSK	Frequency-shift keying
ft-lb.	Foot-pound
FTP	File Transfer Protocol
Gain	An increase in signal relative to a reference
Gbps	Gigabits per second

Glossary, Continued

Headend	Location and equipment that receives data from a satellite (or other) source and reformats that data for input to a broadband distribution network
HEDA	Headend Driver Amplifier
HGD	High Gain Dual
Hertz	A unit of frequency equal to one cycle per second.
Hetrodyne	Changing the frequency of a signal by mixing it with another signal to get the sum and difference of the two.
I/O	Input/output
IC	Integrated circuit
ICIM	Intelligent Communications Interface Module
ICP	Internal Control Program. A series of policies to protect company sensitive and export controlled information.
IDR	Intermediate Data Rate
IEC	International Electrotechnical Commission
IF	Intermediate frequency
IFL	Interfacility link
IP	Internet protocol
Kbps	Kilobits per second
in-lb	Inch-pound
LCD	Liquid crystal display
LCI	Local craft interface
LED	Light-emitting diode
LIFO	Last-in, first-out
LNA	Low-noise amplifier
LNB	Low-noise block converter

Glossary, Continued

LNC	Low-noise converter
LOCATE(TM)	Systems for monitoring, analyzing, or reporting electric power outages
Mbps	Megabits per second
MCU	Master Control Unit
Multipath (multipath transmission)	The phenomenon which results from a signal traveling from point to point by more than one path so that several copies of the signal arrive at the destination at different times or at different angles.
mux	multiplexed
Nanosecond	1 thousandth of a microsecond
Nm	Newton meter
NIU	Network Interface Unit
Node	A branching or exchange point
OEM	Original equipment manufacturer
OOB	Out of band
OIM	Optical interface module
PCB	Printed circuit board
PCM	Pulse code modulation
PDI	Pressure differential indicator
PDU	Power distribution unit
PLL	Phase Lock Loop. An electronic servo system controlling an oscillator to maintain a constant phase angle relative to a reference signal.
PROM	Programmable Read Only Memory
PWB	Printed wiring board
QAM	Quadrature Amplitude Modulation
QPR	Quadrature Partial Response

Glossary, Continued

QPSK	Quadrature Phase-Shift Keying
RC	Reverse conditioner
Reverse path	Signal flow direction toward the headend.
RF	Radio frequency
RF Bypass	A bypass feature that allows subscribers to view a clear analog channel while recording a digital or analog channel on a VCR.
RFI	Radio frequency interference
RMA	Return material authorization
RMS	Root Mean Square
Router	A data communications device which examines a packet and routes the packet to an output port appropriate to the packet destination
RS	Remote Sensing
RX	Receive or receiver
SA	Spectrum analyzer
SAM	Signal analysis meter
SAT	Site acceptance test
S-band	The group of frequencies between 2 and 4 GHz.
SET	Secure electronic transaction
Scattering	Random directional change of a wave or part of a wave caused by an irregular reflecting surface or by passing through an inhomogeneous transmission medium.
SLM	Signal level meter
SM	Status monitor
SMC	Status monitoring and control
SMIU	Status Monitor Interface Unit
SMU	Server Management Unit
S/N or SNR	Signal-to-noise ratio

Glossary, Continued

SNMP	Simple Network Management Protocol
SP	Splitter. It is a device which divides power from an input to deliver multiple outputs or combines multiple inputs into one output.
Spread Spectrum	A modulation technique to spread a narrow band signal over a wide band of frequencies.
Spurious	Anything other than the desired result
SSPA	Solid-state power amplifier
Sweep generator	A signal source which can automatically vary its frequency continuously from one frequency to another.
Synchronous transmission	A method of sending information over a path and separating discrete characters and symbols by a precise separation in time.
TCP/IP	Transmission control protocol/internet protocol
TDM	Time division multiplexing
TNCS	Transmission Network Control System
Torque	Force applied to bolt or screw to tighten the device.
TS	Transport Stream
TTCN	True tilt correction network
Tx	Transmit or transmitter
UBT	Unbalanced triple
UPS	Un-interruptible power supply
Upstream	Signal transmission toward the headend
UTP	Unshielded twisted pair
uV	One millionth of a volt (microvolt)
V	Volt
V AC	Volts alternating current
VBR	Variable bit rate

Glossary, Continued

VCA	Voltage controlled attenuator
V DC	Volts direct current
VOD	Video-on-demand
VOM	Volt ohm meter
W	Watts
WDM	Wave Division Multiplexing
YEDFA	Ytterbium/Erbium Doped Fiber Amplifier



Cisco Systems, Inc.
5030 Sugarloaf Parkway, Box 465447
Lawrenceville, GA 30042

678 277-1120
800 722-2009
www.cisco.com

This document includes various trademarks of Cisco Systems, Inc. Please see the Notices section of this document for a list of the Cisco Systems, Inc. trademarks used in this document.

Product and service availability are subject to change without notice.

© 2001, 2008, 2012 Cisco and/or its affiliates.

All rights reserved.

September 2012 Printed in USA

Part Number 78-713378-01 Rev C