



# Cisco UCS X410c M7 Compute Node

A printed version of this document is only a copy and not necessarily the latest version. Refer to the following link for the latest released version:

<https://www.cisco.com/c/en/us/products/servers-unified-computing/ucs-x-series-modular-system/datasheet-listing.html>

---

<b>OVERVIEW</b>	<b>3</b>
<b>DETAILED VIEWS</b>	<b>5</b>
Cisco UCS X410c M7 Compute Node Front View	5
<b>COMPUTE NODE STANDARD CAPABILITIES and FEATURES</b>	<b>6</b>
<b>CONFIGURING the Cisco UCS X410c M7 Compute Node</b>	<b>9</b>
STEP 1 CHOOSE BASE Cisco UCS X410c M7 Compute Node SKU	10
STEP 2 CHOOSE CPU(S)	11
STEP 3 CHOOSE MEMORY	13
Memory configurations and mixing rules	16
STEP 4 CHOOSE REAR mLOM ADAPTER	19
STEP 5 CHOOSE OPTIONAL REAR MEZZANINE VIC/BRIDGE ADAPTERS	23
STEP 6 CHOOSE OPTIONAL FRONT MEZZANINE ADAPTER	25
STEP 7 CHOOSE OPTIONAL GPU PCIe NODE	26
STEP 8 CHOOSE OPTIONAL GPUs	27
STEP 9 CHOOSE OPTIONAL DRIVES	28
STEP 10 ORDER M.2 SATA SSDs AND RAID CONTROLLER	30
STEP 11 ORDER NVMe BOOT (OPTIONAL)	31
STEP 12 CHOOSE OPTIONAL TRUSTED PLATFORM MODULE	32
STEP 13 CHOOSE OPERATING SYSTEM AND VALUE-ADDED SOFTWARE	33
STEP 14 CHOOSE OPTIONAL OPERATING SYSTEM MEDIA KIT	36
<b>SUPPLEMENTAL MATERIAL</b>	<b>37</b>
Simplified Block Diagram	37
System Board	39
<b>UPGRADING or REPLACING CPUs and MEMORY</b>	<b>40</b>
<b>LEADERSHIP PERFORMANCE WITH 4TH GEN INTEL® XEON® PROCESSORS</b>	<b>41</b>
Intel® Xeon® Processors Notices and Disclaimers	42
<b>TECHNICAL SPECIFICATIONS</b>	<b>43</b>
Dimensions and Weight	43
Environmental Specifications	43
<b>DISCONTINUED EOL PRODUCTS</b>	<b>44</b>

## OVERVIEW

The Cisco UCS X-Series Modular System simplifies your data center, adapting to the unpredictable needs of modern applications while also providing for traditional scale-out and enterprise workloads. It reduces the number of server types to maintain, helping to improve operational efficiency and agility as it helps reduce complexity. Powered by the Cisco Intersight™ cloud operations platform, it shifts your thinking from administrative details to business outcomes with hybrid cloud infrastructure that is assembled from the cloud, shaped to your workloads, and continuously optimized.

The Cisco UCS X410c M7 Compute Node is the computing device to integrate into the Cisco UCS X-Series Modular System. Up to four compute nodes or two compute nodes and two GPU nodes can reside in the 7-rack-unit (7RU) Cisco UCS X9508 Server Chassis, offering high performance and efficiency gains for a wide range of mission-critical enterprise applications, memory-intensive applications and bare-metal and virtualized workloads.

The Cisco UCS X410c M7 Compute Node harnesses the power of the latest 4<sup>th</sup> Gen Intel® Xeon® Scalable Processors (Sapphire Rapids), and offers the following:

- **CPU:** Four 4<sup>th</sup> Gen Intel® Xeon® Scalable Processors (codenamed Sapphire Rapids) with up to 60 cores per processor.
- **Memory:** Up to 16TB with 64 x 256GB DDR5 Memory DIMMs, up to 4800 MT/s, in a 4-sockets configuration.
- **Storage:** Up to 6 hot-pluggable, Solid-State Drives (SSDs), or Non-Volatile Memory Express (NVMe) 2.5-inch drives with a choice of enterprise-class Redundant Array of Independent Disks (RAID) or pass-through controllers with four lanes each of PCIe Gen 4 connectivity and up to 2 M.2 SATA or NVMe drives for flexible boot and local storage capabilities.
- **mLOM virtual interface cards:**
  - Cisco UCS Virtual Interface Card (VIC) 15420 occupies the server's Modular LAN on Motherboard (mLOM) slot, enabling up to 50Gbps (2 x25Gbps) of unified fabric connectivity to each of the chassis Intelligent Fabric Modules (IFMs) for 100Gbps connectivity per server.
  - Cisco UCS Virtual Interface Card (VIC) 15231 occupies the server's Modular LAN on Motherboard (mLOM) slot, enabling up to 100Gbps of unified fabric connectivity to each of the chassis Intelligent Fabric Modules (IFM) for 200Gbps (2x 100Gbps) connectivity per server.
  - Cisco UCS Virtual Interface Card (VIC) 15230 occupies the server's modular LAN on motherboard (mLOM) slot, enabling up to 100 Gbps of unified fabric connectivity to each of the chassis Intelligent Fabric Modules (IFMs) for 100 Gbps connectivity per server with secure boot capability.
- **Optional Mezzanine card:**
  - Cisco UCS Virtual Interface Card (VIC) 15422 can occupy the server's mezzanine slot at the bottom rear of the chassis. An included bridge card extends this VIC's 100Gbps (4 x 25Gbps) of network connections through IFM connectors, bringing the total bandwidth to 100Gbps per VIC 15420 and 15422 (for a total of 200Gbps per server). In addition to IFM connectivity, the VIC 15422 I/O connectors link to Cisco UCS X-Fabric technology.
  - Cisco UCS PCI Mezz card for X-Fabric can occupy the server's mezzanine slot at the bottom rear of the chassis. This card's I/O connectors link to Cisco UCS X-Fabric modules and enable connectivity to the X440p PCIe Node.

- **Security:** Includes secure boot silicon root of trust FPGA, ACT2 anti-counterfeit provisions, and optional Trusted Platform Model (TPM).

*Figure 1 on page 5* shows a front view of the Cisco UCS X410c M7 Compute Node.

**Figure 1 Cisco UCS X410c M7 Compute Node**

Front View with Drives



# DETAILED VIEWS

## Cisco UCS X410c M7 Compute Node Front View

Figure 2 shows a front view of the Cisco UCS X410c M7 Compute Node.

Figure 2 Cisco UCS X410c M7 Compute Node Front View (Drives option)

Storage Drives Option

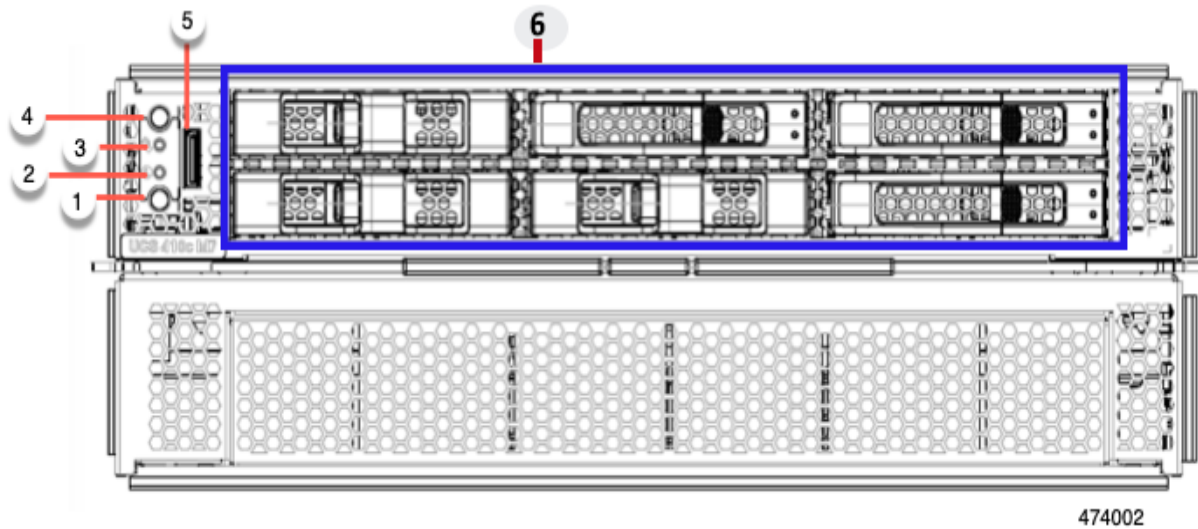

1	Power button/LED	4	Locator LED/Switch
2	System Activity LED	5	External Optical Connector (Oculink) that supports local console functionality.
3	System Health LED	6	Drive Bay slots 1-6

# COMPUTE NODE STANDARD CAPABILITIES and FEATURES

*Table 1* lists the capabilities and features of the base Cisco UCS X410c M7 Compute Node. Details about how to configure the compute node for a listed feature or capability (for example, number of processors, disk drives, or amount of memory) are provided in [CONFIGURING the Cisco UCS X410c M7 Compute Node on page 9](#).

**Table 1 Capabilities and Features**

Capability/Feature	Description
Chassis	The Cisco UCS X410c M7 Compute Node mounts in a Cisco UCS X9508 chassis.
CPU	<ul style="list-style-type: none"> <li>■ Four 4<sup>th</sup> Gen Intel® Xeon® Scalable Processors (codenamed Sapphire Rapids).</li> <li>■ Each CPU has 8 channels with up to 2 DIMMs per channel, for up to 16 DIMMs per CPU.</li> <li>■ UPI Links: Up to Four at 16GT/s</li> </ul>
Chipset	Intel® C741 series chipset
Memory	<ul style="list-style-type: none"> <li>■ 64 total DDR5 DIMM Slots, at up to 4800 MT/s</li> <li>■ 50% peak bandwidth increase over DDR4-3200, all densities are Registered DIMMs (RDIMMs)</li> <li>■ Up to 16TB DDR5 memory DIMM capacity (64x 256GB DIMMs, up to 4800 MT/s)</li> </ul>
Mezzanine Adapter (Rear)	<ul style="list-style-type: none"> <li>■ An optional Cisco UCS Virtual Interface Card 15422 can occupy the server’s mezzanine slot at the bottom of the chassis. A bridge card extends this VIC’s 2x 50Gbps of network connections up to the mLOM slot and out through the mLOM’s IFM connectors, bringing the total bandwidth to 100Gbps per fabric—a total of 200Gbps per server.</li> <li>■ An optional UCS PCIe Mezz card for X-Fabric is also supported in the server’s mezzanine slot. This card’s I/O connectors link to the Cisco UCS X-Fabric modules for UCS X-series Gen4 PCIe node access.</li> </ul>
mLOM	<p>The modular LAN on motherboard (mLOM) cards (the Cisco UCS VIC 15231/15230 and 15420) is located at the rear of the compute node.</p> <ul style="list-style-type: none"> <li>■ Cisco UCS Virtual Interface Card (VIC) 15420 is a Cisco designed PCI Express (PCIe) based card that supports two 2x25G-KR network interfaces to provide Ethernet communication to the network by means of the Intelligent Fabric Modules (IFMs) in the Cisco UCS X9508 chassis. The Cisco UCS VIC 15420 mLOM can connect to the rear mezzanine adapter card with a bridge connector.</li> <li>■ Cisco UCS Virtual Interface Card (VIC) 15231 is a Cisco designed PCI Express (PCIe) based card that supports two 2x100G-KR network interfaces to provide Ethernet communication to the network by means of the Intelligent Fabric Modules (IFMs) in the Cisco UCS X9508 chassis</li> <li>■ Cisco UCS Virtual Interface Card (VIC) 15230 occupies the server’s modular LAN on motherboard (mLOM) slot, enabling up to 100 Gbps of unified fabric connectivity to each of the chassis Intelligent Fabric Modules (IFMs) for 100 Gbps connectivity per server with secure boot capability.</li> </ul>

Table 1 Capabilities and Features (*continued*)

Capability/Feature	Description
Mezzanine Adapters (Front)	<p>One front mezzanine connector that supports:</p> <ul style="list-style-type: none"> <li>■ Up to 6 x 2.5-inch SAS and SATA RAID-compatible SSDs</li> <li>■ Up to 6 x 2.5-inch NVMe PCIe drives</li> <li>■ A mixture of up to six SAS/SATA or NVMe drives</li> </ul>  <p><b>Note:</b> Drives require a RAID or pass-through controller in the front mezzanine module slot</p>
Additional Storage	<ul style="list-style-type: none"> <li>■ Dual 80 mm SATA 3.0 M.2 cards (up to 960GB per card) on a boot-optimized hardware RAID controller</li> <li>■ Dual 80 mm NVMe cards (up to 960GB per card) on a passthrough controller</li> </ul>
Video	<p>Video uses a Matrox G200e video/graphics controller.</p> <ul style="list-style-type: none"> <li>■ Integrated 2D graphics core with hardware acceleration</li> <li>■ DDR4 memory interface supports up to 512 MB of addressable memory (16 MB is allocated by default to video memory)</li> <li>■ Supports display resolutions up to 1920 x 1200 32 bpp@ 60Hz</li> <li>■ Video is available with an Oculink connector on the front panel. An adapter cable (PID UCSX-C-DEBUGCBL) is required to connect the OCuLink port to the transition serial USB and video (SUV) octopus cable.</li> </ul>
Front Panel Interfaces	OCuLink console port. Note that an adapter cable is required to connect the OCuLink port to the transition serial USB and video (SUV) octopus cable.
Power subsystem	Power is supplied from the Cisco UCS X9508 chassis power supplies. The Cisco UCS X410c M7 Compute Node consumes a maximum of 2500W.
Fans	Integrated in the Cisco UCS X9508 chassis.
Integrated management processor	The built-in Cisco Integrated Management Controller enables monitoring of Cisco UCS X410c M7 Compute Node inventory, health, and system event logs.
Baseboard Management Controller (BMC)	ASPEED Pilot IV
ACPI	Advanced Configuration and Power Interface (ACPI) 6.5 Standard Supported. ACPI states S0 and S5 are supported. There is no support for states S1 through S4.
Front Indicators	<ul style="list-style-type: none"> <li>■ Power button and indicator</li> <li>■ System activity indicator</li> <li>■ Location button and indicator</li> </ul>
Management	<b>Cisco Intersight software</b> (SaaS, Virtual Appliance and Private Virtual Appliance)
Fabric Interconnect	Compatible with the Cisco UCS 6454, 64108 and 6536 fabric interconnects

Table 1 Capabilities and Features (*continued*)

Capability/Feature	Description
Chassis	Compatible with the Cisco UCS 9508 X-Series Server Chassis



# CONFIGURING the Cisco UCS X410c M7 Compute Node

Follow these steps to configure the Cisco UCS X410c M7 Compute Node:

- *STEP 1 CHOOSE BASE Cisco UCS X410c M7 Compute Node SKU, page 10*
- *STEP 2 CHOOSE CPU(S), page 11*
- *STEP 3 CHOOSE MEMORY, page 13*
- *STEP 4 CHOOSE REAR mLOM ADAPTER, page 19*
- *STEP 5 CHOOSE OPTIONAL REAR MEZZANINE VIC/BRIDGE ADAPTERS, page 23*
- *STEP 6 CHOOSE OPTIONAL FRONT MEZZANINE ADAPTER, page 25*
- *STEP 7 CHOOSE OPTIONAL GPU PCIe NODE, page 26*
- *STEP 8 CHOOSE OPTIONAL GPUs, page 27*
- *STEP 9 CHOOSE OPTIONAL DRIVES, page 28*
- *STEP 10 ORDER M.2 SATA SSDs AND RAID CONTROLLER, page 30*
- *STEP 11 ORDER NVMe BOOT (OPTIONAL), page 31*
- *STEP 12 CHOOSE OPTIONAL TRUSTED PLATFORM MODULE, page 32*
- *STEP 13 CHOOSE OPERATING SYSTEM AND VALUE-ADDED SOFTWARE, page 33*
- *STEP 14 CHOOSE OPTIONAL OPERATING SYSTEM MEDIA KIT, page 36*
- *SUPPLEMENTAL MATERIAL, page 37*

## STEP 1 CHOOSE BASE Cisco UCS X410c M7 Compute Node SKU

Top Level ordering product ID (PID) of the Cisco UCS X410c M7 Compute Node as shown in [Table 3](#)

Table 2 Top level ordering PID

Product ID (PID)	Description
UCSX-M7-MLB	UCSX M7 Modular Server and Chassis MLB

Verify the product ID (PID) of the Cisco UCS X410c M7 Compute Node as shown in [Table 4](#).

Table 3 PID of the Base Cisco UCS X410c M7 Compute Node

Product ID (PID)	Description
UCSX-410C-M7	Cisco UCS X410c M7 Compute Node 4S Intel 4 <sup>th</sup> Gen CPU without CPU, memory, drive bays, drives, VIC adapter, or mezzanine adapters (ordered as a UCS X9508 chassis option)
UCSX-410C-M7-U	Cisco UCS X410c M7 Compute Node 4S Intel 4 <sup>th</sup> Gen CPU without CPU, memory, drive bays, drives, VIC adapter, or mezzanine adapters (ordered standalone)

A base Cisco UCS X410c M7 Compute Node ordered in [Table 3](#) does not include any components or options. They must be selected during product ordering.

Please follow the steps on the following pages to order components such as the following, which are required in a functional compute node:

- CPUs
- Memory
- Cisco storage RAID or passthrough controller with drives (or blank, for no local drive support)
- SAS, SATA, M.2 or NVMe drives
- Cisco adapters (such as the 15000 series VIC or Bridge)

## STEP 2 CHOOSE CPU(S)

The standard CPU features are:

- The 4<sup>th</sup> Gen Intel® Xeon® Scalable Processors (codenamed Sapphire Rapids) are paired with Intel® C741 series chipset
- Up to 60 cores
- Cache size of up to 112.50 MB
- Power: Up to 350Watts
- UPI Links: Up to Four at 16GT/s

With 4th Gen Intel® Xeon® processors, improve performance efficiency for critical workloads with the most built-in accelerators. See 4th gen intel xeon benefit pillars in [LEADERSHIP PERFORMANCE WITH 4TH GEN INTEL® XEON® PROCESSORS](#).

### Select CPUs

The available CPUs are listed in [Table 4](#).

Table 4 Available CPUs

Product ID (PID)	Cores (C)	Clock Freq (GHz)	Power (W)	Cache Size (MB)	Highest DDR5 DIMM Clock Support (MT/s)
<b>8000 Series Processors</b>					
UCSX-CPU-I8490H	60	1.90	350	112.50	4800
UCSX-CPU-I8468H	48	2.10	330	105.00	4800
UCSX-CPU-I8460H	40	2.20	330	105.00	4800
UCSX-CPU-I8454H	32	2.10	270	82.50	4800
UCSX-CPU-I8450H	28	2.00	250	75.00	4800
UCSX-CPU-I8444H	16	2.90	270	45.00	4800
<b>6000 Series Processors</b>					
UCSX-CPU-I6448H	32	2.40	250	60.00	4800
UCSX-CPU-I6434H	8	3.70	195	22.50	4800
UCSX-CPU-I6418H	24	2.10	185	60.00	4800
UCSX-CPU-I6416H	18	2.20	165	45.00	4800

## Supported Configurations

---

(1) DRAM configuration:

- Select four identical CPUs listed in [Table 4 on page 11](#)

(2) Configurations with NVMe PCIe drives:

- Select four identical CPUs listed in [Table 4 on page 11](#)

(3) Four-CPU Configuration

- Choose four identical CPUs from any one of the rows of [Table 4 Available CPUs, page 11](#)

### STEP 3 CHOOSE MEMORY

The [Table 5](#) below describes the main memory DIMM features supported on Cisco UCS X410c M7 Compute Node.

**Table 5 X410c M7 Main Memory Features**

Memory DIMM server technologies	Description
Maximum DDR5 memory clock speed	Up to 4800 MT/s 1DPC; Up to 4400 MT/S 2DPC
Operational voltage	1.1 Volts
DRAM Fab. density	16Gb
DRAM DIMM type	RDIMM (Registered DDR5 DIMM)
Memory DIMM organization	Eight memory DIMM channels per CPU; up to 2 DIMMs per channel
Maximum number of DRAM DIMM per server	64 (4-Socket)
DRAM DIMM densities and ranks	16GB 1Rx8, 32GB 1Rx4, 64GB 2Rx4, 96GB 2Rx4, 128GB 4Rx4, 256GB 8Rx4
Maximum system capacity (DRAM DIMMs only)	16TB (64x256GB)

Figure 3 Cisco UCS X410c M7 Compute Node Memory Organization

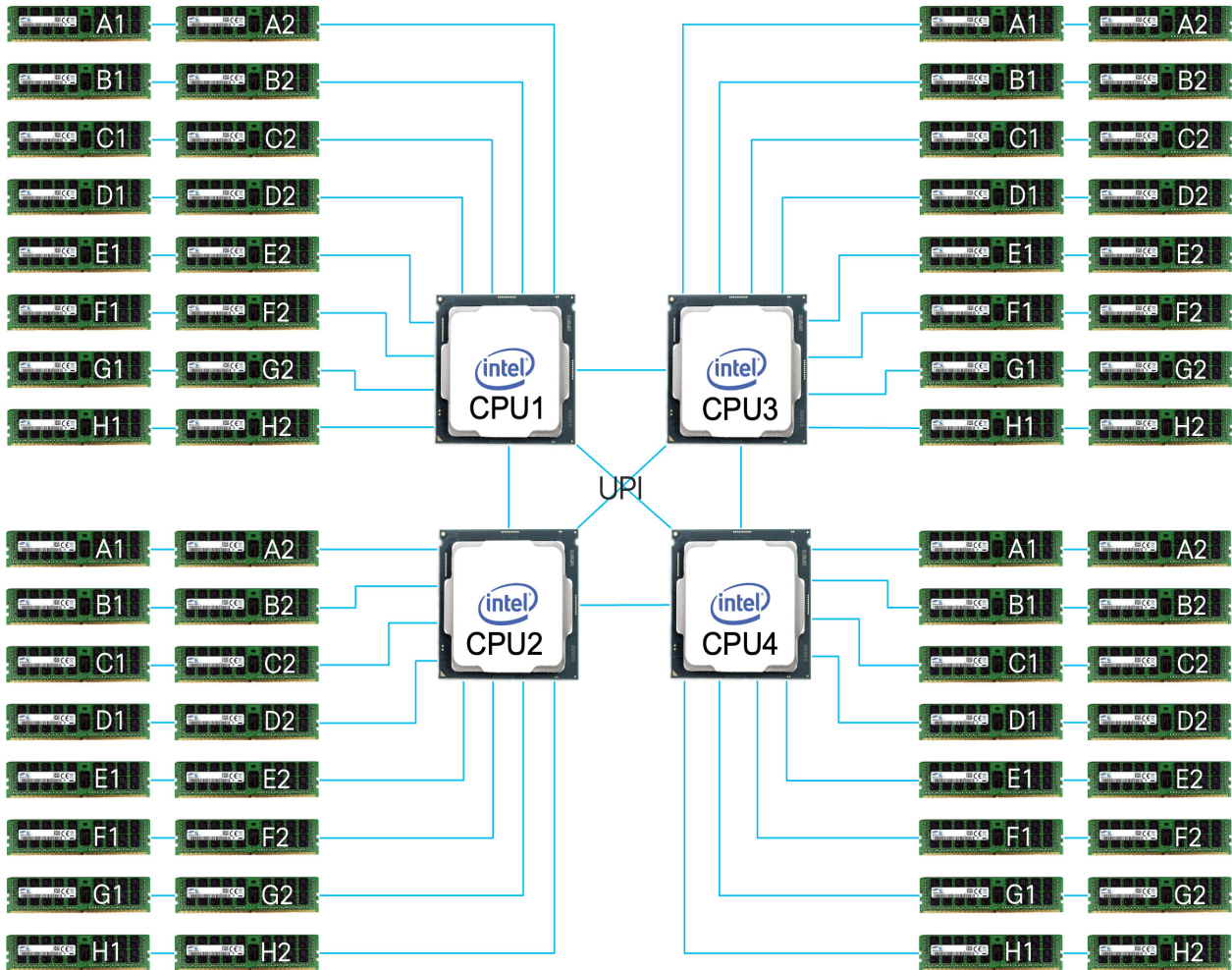

## Select DIMMs and Memory Mirroring

Select the memory configuration and whether or not you want the memory mirroring option. The available memory DIMMs and mirroring option are listed in [Table 6](#).



**NOTE:** When memory mirroring is enabled, the memory subsystem simultaneously writes identical data to two channels. If a memory read from one of the channels returns incorrect data due to an uncorrectable memory error, the system automatically retrieves the data from the other channel. A transient or soft error in one channel does not affect the mirrored data, and operation continues unless there is a simultaneous error in exactly the same location on a DIMM and its mirrored DIMM. Memory mirroring reduces the amount of memory available to the operating system by 50% because only one of the two populated channels provides data.

**Table 6 Available DDR5 DIMMs**

Product ID (PID)	PID Description
<b>DRAMs</b>	
UCSX-MRX16G1RE1	16GB DDR5-4800 RDIMM 1Rx8 (16Gb)
UCSX-MRX32G1RE1	32GB DDR5-4800 RDIMM 1Rx4 (16Gb)
UCSX-MRX64G2RE1	64GB DDR5-4800 RDIMM 2Rx4 (16Gb)
UCSX-MRX96G2RF3 <sup>1,2</sup>	96GB DDR5-5600 RDIMM 2Rx4 (24Gb)
UCSX-MR128G4RE1	128GB DDR5-4800 RDIMM 4Rx4 (16Gb)
UCSX-MR256G8RE1	256GB DDR5-4800 RDIMM 8Rx4 (16Gb)
<b>Memory Mirroring Option</b>	
N01-MMIRRORD	Memory mirroring option
<b>Accessories/spare included with Memory configuration:</b>	
<ul style="list-style-type: none"> <li>■ UCS-DDR5-BLK<sup>3</sup> is auto included for the unselected DIMMs slots</li> </ul>	

### Notes:

1. Memory will operate at the maximum speed of the Intel 4th Gen. CPU memory controller, ranging from 4000 MT/s to 4800 MT/s. Check [Table 10](#) for details on 1DPC and 2 DPC maximum speed with 4th Gen. CPUs.
2. Available in Q2'24.
3. Any empty DIMM slot must be populated with a DIMM blank to maintain proper cooling airflow.

## Memory configurations and mixing rules



**GOLDEN RULE:** Memory on every CPU socket shall be configured identically. Therefore, the memory configuration of CPU-4 for a 4-socket system. Unbalanced populations are unsupported.

- System speed is dependent on the CPU DIMM speed support. Refer to [Available CPUs on page 11](#) for DIMM speeds.
- For full details on supported memory configurations see the [M7 Memory Guide](#)
- DIMM Count Rules:

**Table 7 Allowed DIMM Count for 4-CPU<sup>1</sup>**

Allowed DIMM Count rules	Minimum Count	Maximum Count	Allowed Count	Not Allowed Count
<b>16GB, 32GB, 64GB, 128GB, 256GB (4th Gen. CPUs)</b>				
DIMM count for 4-CPU	4	64	4,8,16,24,32,48,64	12,20,28,36,40,44,52,56,60
<b>96GB (4th Gen. CPUs)<sup>2,3</sup></b>				
DIMM count for 4-CPU	32	64	32,64	4,8,12,16,20,24,28 36,40,44,48,52,56,60

**Notes:**

1. 48 DIMMs count for 4-CPU configurations are only allowed when all DIMMs have the same density.
2. x410c server model supports only 8xDIMMs and 16xDIMMs per CPU (32xDIMMs and 64xDIMMs for 4 CPUs).
3. For x410c server model, 96GB is only supported on Intel 4th Gen. CPUs Platinum Series 8444H, 8450H, 8454H, 8460H, 8468H, 8490H SKUs.

- DIMM Population Rules:
  - Each channel has two memory slots (for example, channel A = slots A1 and A2)
    - A channel can operate with one or two DIMMs installed.
    - If a channel has only one DIMM, populate slot 1 first (the blue slot).
  - When both CPUs are installed, populate the memory slots of each CPU identically. Fill the blue slots (slot 1) in the memory channels first according to the recommended DIMM populations in [Table 8.0](#) and [Table 8.1](#)

**Table 8.0 M7 DIMM population order for 16GB, 32GB, 64GB, 128GB, 256GB**

#DIMMs per CPU	DIMM Population - 16GB, 32GB, 64GB, 128GB, 256GB (4th Gen. CPUs) <sup>1</sup>	
	Slot 1 (Blue)	Slot 2 (Black)
1	A1	-
2	A1, G1	-
4	A1, C1, E1, G1	-
6	A1, C1, D1, E1, F1, G1	-
8	A1, B1, C1, D1, E1, F1, G1, H1	-
12 <sup>2</sup>	A1, B1, C1, D1, E1, F1, G1, H1	A2, C2, E2, G2



**Table 8.0 M7 DIMM population order for 16GB, 32GB, 64GB, 128GB, 256GB**

16	A1, B1, C1, D1, E1, F1, G1, H1	A2, B2, C2, D2, E2, F2, G2, H2
----	--------------------------------	--------------------------------

**Notes:**

1. See [DIMM Mixing Rules](#) for allowed combinations across slots 1 and 2.
2. Only valid when DIMMs in blue and black slots are the same density.

**Table 8.1 M7 DIMM population order for 96GB**

#DIMMs per CPU	DIMM Population - 96GB (4th Gen. CPUs only) <sup>1,2</sup>	
	Slot 1 (Blue)	Slot 2 (Black)
8	A1,B1,C1,D1,E1,F1,G1,H1	-
16	A1,B1,C1,D1,E1,F1,G1,H1	A2,B2,C2,D2,E2,F2,G2,H2

**Notes:**

1. x410c server model supports only 8xDIMMs and 16xDIMMs per CPU (32xDIMMs and 64xDIMMs for 4 CPUs)
2. For x410c server model, 96GB is only supported on Intel 4th Gen. CPUs Platinum Series 8444H, 8450H, 8454H, 8460H, 8468H, 8490H SKUs

■ DIMM Mixing Rules:

- Higher rank DIMMs shall be populated on Slot 1.
- Mixing different DIMM densities in the same slot across channels is not supported. All populated slots of the same color must have the same DIMM density.
- Mixing DDR5-4800 and DDR5-5600 memory PIDs is not allowed.
- The DIMM mixing rules matrix is described in the [Table 9](#), below.

**Table 9 Supported DIMM mixing and population across 2 slots in each channel**

Channel Mixing		DIMM Slot 2 (Black)					
		16GB	32GB	64GB	96GB	128GB	256GB
DIMM Slot 1 (Blue)		1Rx8	1Rx4	2Rx4	2Rx4	4Rx4	8Rx4
16GB	1Rx8	Yes <sup>1</sup>	No	No	No	No	No
32GB	1Rx4	No	Yes <sup>1</sup>	No	No	No	No
64GB	2Rx4	No	Yes <sup>2</sup>	Yes <sup>1</sup>	No	No	No
96GB	2Rx4	No	No	No	Yes <sup>1</sup>	No	No
128GB	4Rx4	No	No	No	No	Yes <sup>1</sup>	No
256GB	8Rx4	No	No	No	No	Yes <sup>2</sup>	Yes <sup>1</sup>

**Notes:**

1. Only 6 or 8 channels are allowed (for 2, 4, or 8 DIMMs you would just populate 1 DPC on 2, 4, or 8 channels)

2. When mixing two different DIMM densities, all 8 channels per CPU must be populated. Use of fewer than 8 channels (16 slots per CPU) is not supported.

■ Memory Limitations:

- Memory on every CPU socket shall be configured identically.
- Refer to [Table 8](#) and [Table 9](#) for DIMM population and DIMM mixing rules.
- Cisco memory from previous generation servers (DDR3 and DDR4) is not supported with the M7 servers.

■ For best performance, observe the following:

- For optimum performance, populate at least one DIMM per memory channel per CPU. When one DIMM per channel is used, it must be populated in DIMM slot 1 (blue slot farthest away from the CPU) of a given channel.
- The maximum 2 DPC speed is 4400 MT/s, refer to [Table 10](#) for the details.

Table 10 DDR5 memory DIMM 1DPC and 2DPC max speed matrix

4th Gen. CPU Shelves and Memory Speed	1DPC	2DPC
	All RDIMMs	All RDIMMs
Platinum Series 8	4800 MT/s	4400 MT/s
Gold Series 6	4800 MT/s	4400 MT/s



**NOTE:** For full details on supported memory configurations see the [M7 Memory Guide](#)

---

## STEP 4 CHOOSE REAR mLOM ADAPTER

The Cisco UCS X410c M7 Compute Node must be ordered with a Cisco VIC mLOM Adapter. The adapter is located at the back and can operate in a single-CPU or dual-CPU configuration.

[Table 11](#) shows the mLOM adapter choices.

Table 11 mLOM Adapters

Product ID (PID)	Description	Connection type
UCSX-ML-V5D200G-D	Cisco UCS VIC 15231 2x100G mLOM for X Compute Node	mLOM
UCSX-MLV5D200GV2D	Cisco UCS VIC 15230 modular LOM w/Secure Boot X Compute Node	mLOM
UCSX-ML-V5Q50G-D	UCS VIC 15420 4x25G secure boot mLOM for X Compute Node	mLOM



### NOTE:

- VIC 15420, or 15231/15230 are supported with both X9108-IFM-25G and X9108-IFM-100G. VIC 15420 will operate at 4x 25G with both X9108-IFM-25G and X9108-IFM-100G. While, VIC 15231/15230 will operate at 4x 25G with X9108-IFM-25G and at 2x 100G with X9108-IFM-100G.
- The mLOM adapter is mandatory for the Ethernet connectivity to the network by means of the IFMs and has x16 PCIe Gen4 connectivity with Cisco UCS VIC 15420 or x16 Gen4 connectivity with Cisco UCS VIC 15231/15230 towards the CPU1.
- There is no backplane in the Cisco UCS X9508 chassis; thus, the compute nodes directly connect to the IFMs using Orthogonal Direct connectors.
- [Figure 5](#) shows the location of the mLOM and rear mezzanine adapters on the Cisco UCS X410c M7 Compute Node. The bridge adapter connects the mLOM adapter to the rear mezzanine adapter.

Figure 4 Location of mLOM and Rear Mezzanine Adapters

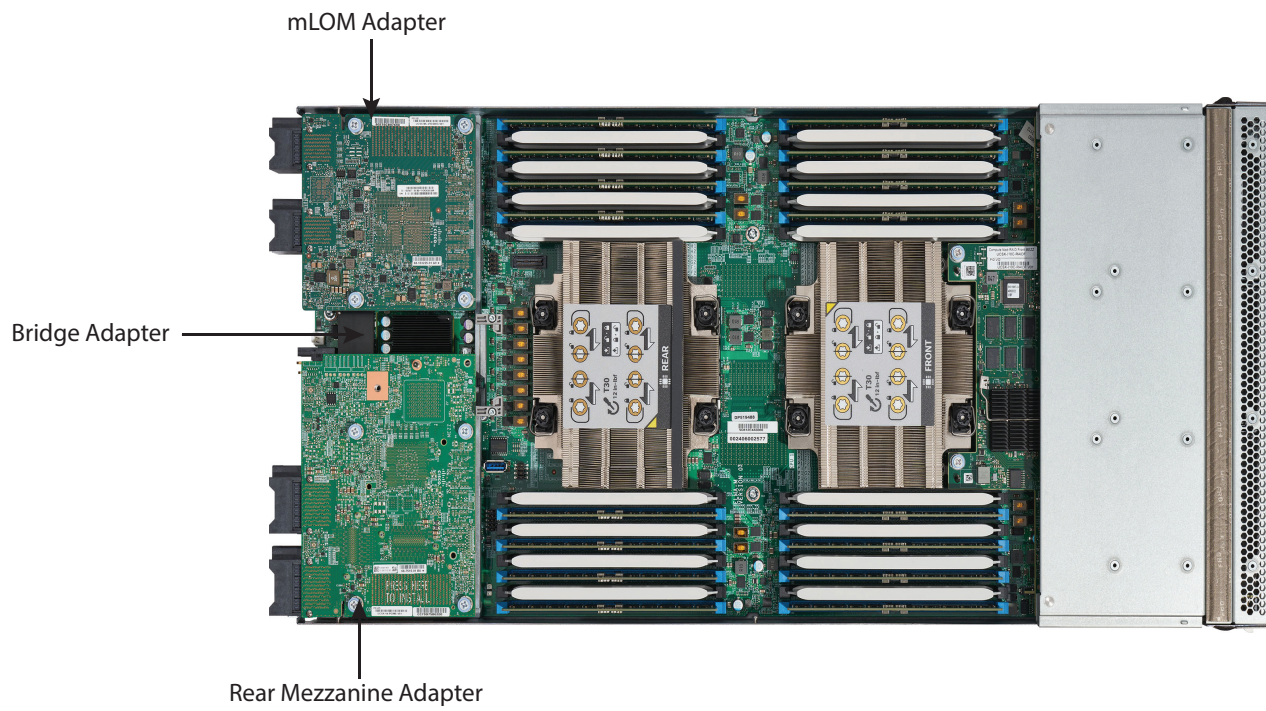

Figure 5 shows the network connectivity from the mLOM out to the 25G IFMs.

Figure 5 Network Connectivity 25G IFMs

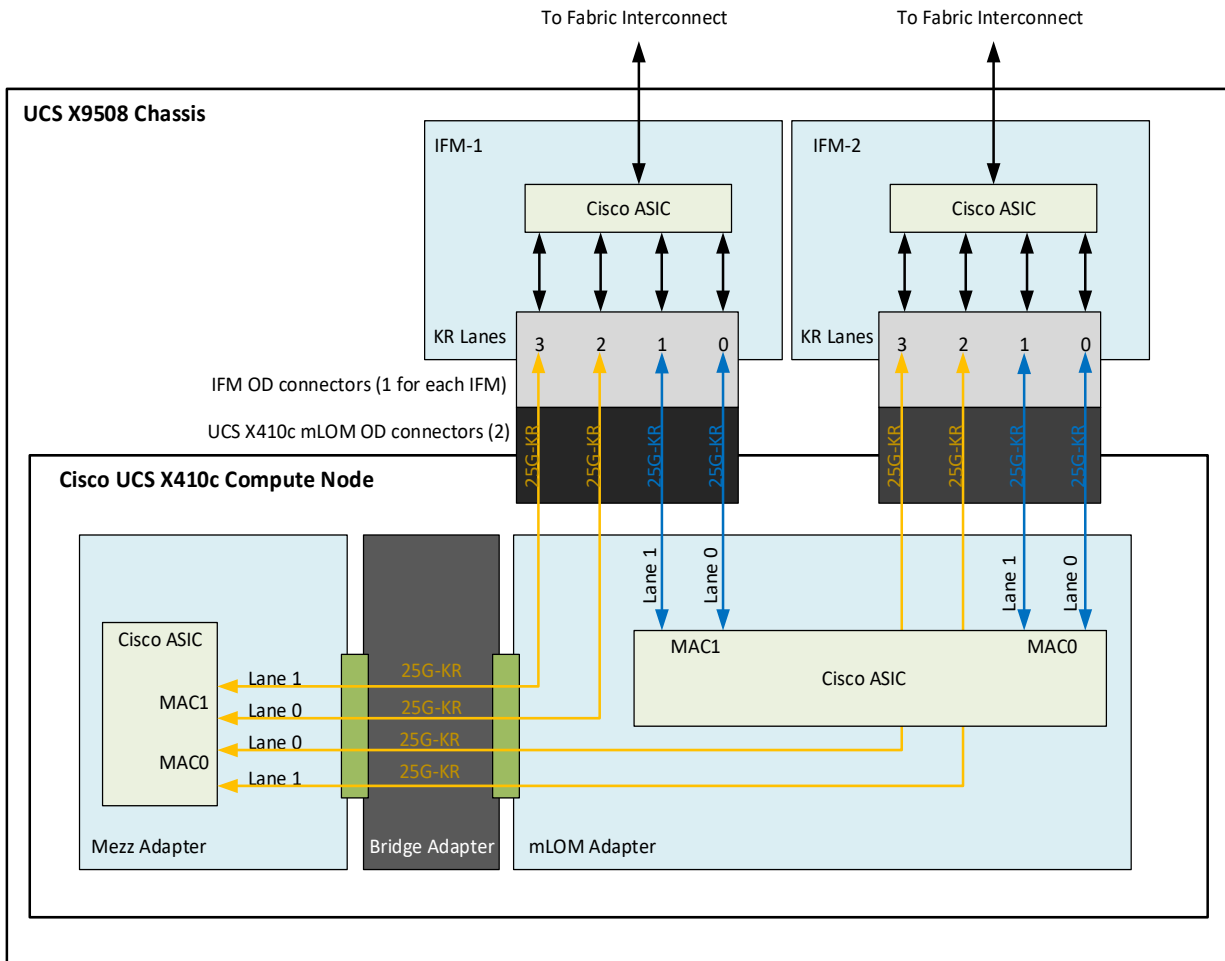
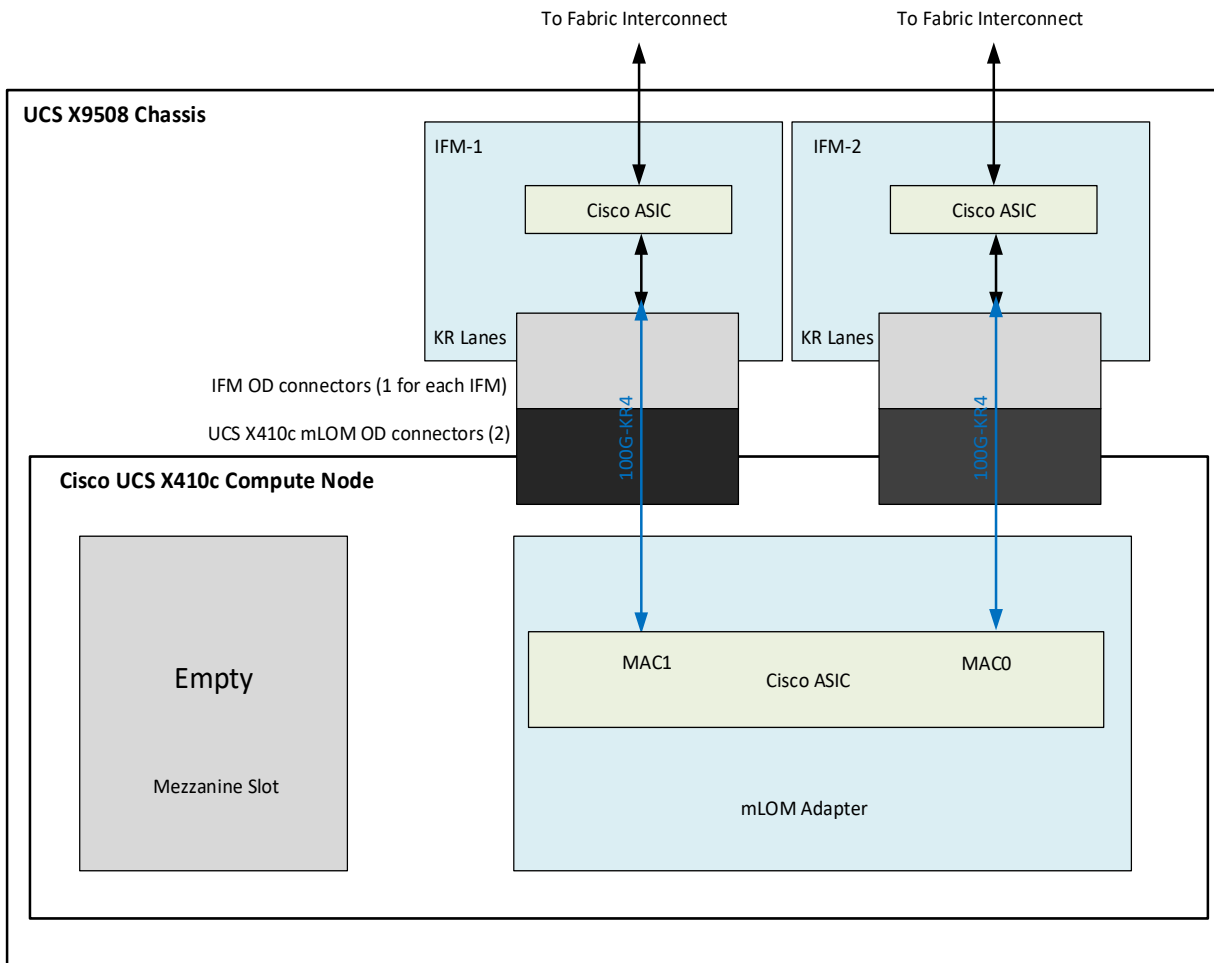

Figure 6 shows the network connectivity from the mLOM out to the 100G IFMs.

Figure 6 Network Connectivity 100G IFMs



## STEP 5 CHOOSE OPTIONAL REAR MEZZANINE VIC/BRIDGE ADAPTERS

The Cisco UCS X410c M7 Compute Node has one rear mezzanine adapter connector which can have a UCS VIC 15422 Mezz card that can be used as a second VIC card on the compute node for network connectivity or as a connector to the X440p PCIe node via X-Fabric modules. The same mezzanine slot on the compute node can also accommodate a pass-through mezzanine adapter for X-Fabric which enables compute node connectivity to the X440p PCIe node. Refer to [Table 12](#) for supported adapters.

Table 12 Available Rear Mezzanine Adapters

Product ID(PID)	PID Description	Connector Type
<b>Cisco VIC Card</b>		
UCSX-V4-PCIME-D <sup>1</sup>	UCS PCI Mezz Card for X-Fabric	Rear Mezzanine connector on motherboard
UCSX-ME-V5Q50G-D	UCS VIC 15422 4x25G secure boot mezz for X Compute Node	Rear Mezzanine connector on motherboard
<b>Cisco VIC Bridge Card<sup>2</sup></b>		
UCSX-V5-BRIDGE-D	UCS VIC 15000 bridge to connect mLOM and mezz X Compute Node (This bridge to connect the Cisco VIC 15420 mLOM and Cisco VIC 15422 Mezz for the X410c M7 Compute Node)	One connector on Mezz card and one connector on mLOM card

### Notes:

1. If this adapter is selected, then two CPUs are required and UCSX-ME-V5Q50G-D or UCSX-V4-PCIME-D is required.
2. Included with the Cisco VIC 15422 mezzanine adapter.



**NOTE:** The UCSX-V4-PCIME-D rear mezzanine card for X-Fabric has PCIe Gen4 x16 connectivity towards each CPU1 and CPU2. Additionally, the UCSX-V4-PCIME-D also provides two PCIe Gen4 x16 to each X-fabric. This rear mezzanine card enables connectivity from the X410c M7 Compute Node to the X440p PCIe node.

Table 13 Throughput Per UCS X410c M7 Server

X410c M7 Compute Node	FI-6536 + X9108-IFM-100G	FI-6536/6400 + X9108-IFM-25G	FI-6536 + X9108-IFM-25G/100G or FI-6400 + X9108-IFM-25G	FI-6536 + X9108-IFM-25G/100G or FI-6400 + X9108-IFM-25G	
X410c configuration	VIC 15231/15230	VIC 15231/15230	VIC 15420	VIC 15420 + VIC 15422	
Throughput per node	200G (100G per IFM)	100G (50G per IFM)	100G (50G per IFM)	200G (100G per IFM)	
vNICs needed for max BW	2	2	2	4	
KR connectivity from VIC to each IFM	1x 100GKR	2x 25GKR	2x 25GKR	4x 25GKR	
Single vNIC throughput on VIC	100G (1x100GKR)	50G (2x25G KR)	50G (2x25G KR)	50G (2x25G KR)	50G (2x25G KR)
Max Single flow BW per vNIC	100G	25G	25G	25G	25G
Single vHBA throughput on VIC	100G	50G	50G	50G	50G

**Supported Configurations**

- One of mLOM VIC from [Table 11](#) is always required.
- If a UCSX-ME-V5Q50G-D rear mezzanine VIC card is installed, a UCSX-V5-BRIDGE-D VIC bridge card is included and connects the mLOM to the mezzanine adapter.
- The UCSX-ME-V5Q50G-D rear mezzanine card has Ethernet connectivity to the IFM using the UCSX-V5-BRIDGE-D and has a PCIe Gen4 x16 connectivity towards CPU2. Additionally, the UCSX-ME-V5Q50G-D also provides two PCIe Gen4 x16 to each X-fabric.
- All the connections to Cisco UCS X-Fabric 1 and Cisco UCS X-Fabric 2 are through the Molex Orthogonal Direct (OD) connector on the mezzanine card.
- The rear mezzanine card has 32 x16PCIe lanes to each Cisco UCS X-Fabric for I/O expansion to enable resource consumption from the PCIe resource nodes.



## STEP 6 CHOOSE OPTIONAL FRONT MEZZANINE ADAPTER

The Cisco UCS X410c M7 Compute Node has one front mezzanine connector that can accommodate one of the following mezzanine cards:

- Pass-through controller for up to 6 U.2/U.3 NVMe drives
- RAID controller (RAID levels 0, 1, 5, 6, 10, and 50) for 6 SAS/SATA/NVMe drives



### NOTE:

- The Cisco UCS X410c M7 Compute Node can be ordered with or without the front mezzanine adapter. Refer to [Table 14 Available Front Mezzanine Adapters](#)
- Only one Front Mezzanine connector per Server
- RAID with NVMe drives is only supported with the NVMe U.3 drives as they connect to the RAID controller and RAID is not supported with the U.2 NVME drives as they directly interface with the server via the PCIe bus.

Table 14 Available Front Mezzanine Adapters

Product ID(PID)	PID Description	Connector Type
UCSX-X10C-PT4F-D	Cisco UCS X410c M7 Compute Node compute pass through controller for up to 6 NVMe drives	Front Mezzanine
UCSX-X10C-RAIDF-D	Cisco UCS X210c M7 Compute Node RAID controller w/4GB Cache, with LSI 3900 for up to 6 SAS/SATA/NVMe drives (SAS/SATA and NVMe drives can be mixed)	Front Mezzanine

## STEP 7 CHOOSE OPTIONAL GPU PCIe NODE

Refer to [Table 15](#) for GPU PCIe Node

Table 15 GPU PCIe Node

Product ID(PID)	PID Description
UCSX-440P-D	UCS X-Series Gen4 PCIe node



**NOTE:** If UCSX-440P-D is selected, then rear mezzanine is required.

---

## STEP 8 CHOOSE OPTIONAL GPUS

### Select GPU Options

The available PCIe node GPU options are listed in [Table 16](#).

**Table 16 Available PCIe GPU Cards supported on the PCIe Node**

GPU Product ID (PID)	PID Description	Maximum number of GPUs per node
UCSX-GPU-A16-D	NVIDIA A16 PCIE 250W 4X16GB	2
UCSX-GPU-A40-D	TESLA A40 RTX, PASSIVE, 300W, 48GB	2
UCSX-GPU-A100-80-D	TESLA A100, PASSIVE, 300W, 80GB	2
UCSX-GPU-H100-80	TESLA H100, PASSIVE, 350W, 80GB	2
UCSX-GPU-L4	NVIDIA L4 Tensor Core, 70W, 24GB	4
UCSX-GPU-L40	NVIDIA L40 300W, 48GB wPWR CBL	2
UCSX-GPU-L40S	NVIDIA L40S: 350W, 48GB, 2-slot FHFL GPU	2

**Notes:**

1. Required power cables are included with the riser cards in the X440p PCIe node.

## STEP 9 CHOOSE OPTIONAL DRIVES

The Cisco UCS X410c M7 Compute Node can be ordered with or without drives. The drive options are:

- One to six 2.5-inch small form factor SAS/SATA SSDs or PCIe U.2/U.3 NVMe drives
  - Hot-pluggable
  - Sled-mounted

Select one or two drives from the list of supported drives available in [Table 17](#).

**Table 17 Available Drive Options**

Product ID (PID)	Description	Drive Type	Speed	Size
<b>SAS/SATA SSDs<sup>1,2,3</sup></b>				
<b>Self-Encrypted Drives (SED)</b>				
UCSX-SD38TBKNK9-D	3.8TB Enterprise Value SAS SSD (1X DWPD, SED)	SAS		3.8TB
UCSXSD960GBKNK9-D	960GB 2.5" Enterprise value 12G SAS SSD (1X endurance, FIPS)	SAS		960GB
UCSXSD800GBKNK9-D	800GB Enterprise performance SAS SSD (3X DWPD, SED)	SAS		800GB
UCSX-SD960GM2NK9D	960GB 2.5in Enter Value 6G SATA Micron G2 SSD (SED)	SATA	6G	960GB
UCSX-SD19TEM2NK9D	1.9TB 2.5in Enter Value 6G SATA Micron G2 SSD (SED)	SATA	6G	800GB
UCSX-SD38TEM2NK9D	3.8TB 2.5in Enter Value 6G SATA Micron G2 SSD (SED)	SATA	6G	1.6TB
UCSX-SD76TEM2NK9D	7.6TB 2.5in Enter Value 6G SATA Micron G2 SSD (SED)	SATA	6G	3.8TB
<b>Enterprise Performance SSDs (high endurance, supports up to 3X DWPD (drive writes per day))</b>				
UCSXSD800GK3XEP-D	800GB 2.5in Enterprise Performance 12G SAS SSD (3X endurance)	SAS	12G	800GB
UCSX-SD64TS3XEP-D	6.4TB 2.5in Enter Perf 12G SAS SSD (3X)	SAS	12G	6.4TB
UCSX-SD19T63XEP-D	1.9TB 2.5 inch Enterprise performance 6G SATA SSD (3X endurance)	SATA	6G	1.9TB
UCSXSD480G63XEP-D	480GB 2.5in Enterprise performance 6G SATA SSD (3X endurance)	SATA	6G	480GB
UCSXSD960G63XEP-D	960GB 2.5 inch Enterprise performance 6G SATA SSD (3X endurance)	SATA	6G	960GB
UCSX-SD38T63XEP-D	3.8TB 2.5 in Enterprise performance 6G SATA SSD (3X endurance)	SATA	6G	3.8TB
<b>Enterprise Value SSDs (Low endurance, supports up to 1X DWPD (drive writes per day))</b>				
UCSXSD38T6I1XEV-D	3.8TB 2.5 inch Enterprise Value 6G SATA SSD	SATA	6G	3.8TB
UCSXSD19T6S1XEV-D	1.9TB 2.5 inch Enterprise Value 6G SATA SSD	SATA	6G	1.9TB
UCSXSD76T6S1XEV-D	7.6TB 2.5 inch Enterprise Value 6G SATA SSD	SATA	6G	7.6TB
UCXS480G6I1XEV-D	480 GB 2.5 inch Enterprise Value 6G SATA Intel SSD	SATA	6G	480GB
UCXS960G6I1XEV-D	960GB 2.5 inch Enterprise Value 6G SATA Intel SSD	SATA	6G	960GB
UCSX-SD19TM1XEV-D	1.9TB 2.5in Enter Value 6G SATA Micron G1 SSD	SATA	6G	1.9TB
UCSXSD960GK1XEV-D	960GB 2.5in Enter Value 12G SAS Kioxia G1 SSD	SAS	12G	960GB
UCSX-SD76TS1XEV-D	7.6TB 2.5in Enter Value 12G SAS Seagate SSD	SAS	12G	7.6TB
UCSX-SD15TK1XEV-D	15.3TB 2.5in Enter Value 12G SAS Kioxia G1 SSD	SAS	12G	15.3TB

Table 17 Available Drive Options (*continued*)

Product ID (PID)	Description	Drive Type	Speed	Size
<b>NVMe<sup>4,5</sup></b>				
UCSX-NVME4-15360D	15.3TB 2.5in U.2 P5520 NVMe High Perf Medium Endurance	NVMe	U.2	15.3TB
UCSX-NVME4-1600-D	1.6TB 2.5in U.2 P5620 NVMe High Perf High Endurance	NVMe	U.2	1.6TB
UCSX-NVME4-1920-D	1.9TB 2.5in U.2 P5520 NVMe High Perf Medium Endurance	NVMe	U.2	1.9TB
UCSX-NVME4-3200-D	3.2TB 2.5in U.2 P5620 NVMe High Perf High Endurance	NVMe	U.2	3.2TB
UCSX-NVME4-3840-D	3.8TB 2.5in U.2 P5520 NVMe High Perf Medium Endurance	NVMe	U.2	3.8TB
UCSX-NVME4-6400-D	6.4TB 2.5in U.2 P5620 NVMe High Perf High Endurance	NVMe	U.2	6.4TB
UCSX-NVME4-7680-D	7.6TB 2.5in U.2 P5520 NVMe High Perf Medium Endurance	NVMe	U.2	7.6TB
UCSX-NVMEXPI400-D	400GB 2.5in U.2 Intel P5800X Optane NVMe Extreme Perform SSD	NVMe	U.2	400GB
UCSX-NVMEXPI800-D	800GB 2.5in U.2 Intel P5800X Optane NVMe Extreme Perform SSD	NVMe	U.2	800GB
UCSX-NVMEG4M1536D	15.3TB 2.5in U.3 Micron 7450 NVMe High Perf Medium Endurance	NVMe	U.3	15.3TB
UCSX-NVMEG4M1600D	1.6TB 2.5in U.3 Micron 7450 NVMe High Perf High Endurance	NVMe	U.3	1.6TB
UCSX-NVMEG4M1920D	1.9TB 2.5in U.3 Micron 7450 NVMe High Perf Medium Endurance	NVMe	U.3	1.9TB
UCSX-NVMEG4M3200D	3.2TB 2.5in U.3 Micron 7450 NVMe High Perf High Endurance	NVMe	U.3	3.2TB
UCSX-NVMEG4M3840D	3.8TB 2.5in U.3 Micron 7450 NVMe High Perf Medium Endurance	NVMe	U.3	3.8TB
UCSX-NVMEG4M6400D	6.4TB 2.5in U.3 Micron 7450 NVMe High Perf High Endurance	NVMe	U.3	6.4TB
UCSX-NVMEG4M7680D	7.6TB 2.5in U.3 Micron 7450 NVMe High Perf Medium Endurance	NVMe	U.3	7.6TB
UCSX-NVMEG4-M960D	960GB 2.5in U.3 Micron 7450 NVMe High Perf Medium Endurance	NVMe	U.3	960GB
<b>NOTE:</b> Cisco uses solid state drives from several vendors. All solid state drives are subject to physical write limits and have varying maximum usage limitation specifications set by the manufacturer. Cisco will not replace any solid state drives that have exceeded any maximum usage specifications set by Cisco or the manufacturer, as determined solely by Cisco.				

**Notes:**

1. SSD drives require the **UCSX-X10C-RAIDF-D** front mezzanine adapter
2. For SSD drives to be in a RAID group, two identical SSDs must be used in the group.
3. If SSDs are in JBOD Mode, the drives do not need to be identical.
4. NVMe drives require a front mezzanine the **UCSX-X10C-PT4F-D** pass through controller or **UCSX-X10C-RAIDF-D** RAID controller.
5. A maximum of 4 U.2 NVMe drives or 6 U.3 NVMe drives can be ordered with RAID controller.

## STEP 10 ORDER M.2 SATA SSDs AND RAID CONTROLLER

- **Cisco 6GB/s SATA Boot-Optimized M.2 RAID Controller (included):** Boot-Optimized RAID controller (UCSX-M2-HWRD-FPS) for hardware RAID across two SATA M.2 storage modules. The Boot-Optimized RAID controller plugs into the motherboard and the M.2 SATA drives plug into the Boot-Optimized RAID controller.



**NOTE:**

- The UCSX-M2-HWRD-FPS is auto included with the server configuration
- The UCSX-M2-HWRD-FPS controller supports RAID 1 and JBOD mode and is available only with 240GB and 960GB M.2 SATA SSDs.
- Cisco IMM is supported for configuring of volumes and monitoring of the controller and installed SATA M.2 drives
- Hot-plug replacement is not supported. The compute node must be powered off to replace.
- The Boot-Optimized RAID controller supports Windows and Linux Operating Systems

**Table 18 Boot-Optimized RAID controller (auto included)**

Product ID (PID)	PID Description
UCSX-M2-HWRD-FPS	UCSX Front panel with M.2 RAID controller for SATA drives

- **Select Cisco M.2 SATA SSDs:** Order one or two matching M.2 SATA SSDs. This connector accepts the boot-optimized RAID controller (see [Table 18](#)). Each boot-optimized RAID controller can accommodate up to two SATA M.2 SSDs shown in [Table 19](#).



**NOTE:**

- Each boot-optimized RAID controller can accommodate up to two SATA M.2 SSDs shown in [Table 19](#). The boot-optimized RAID controller plugs into the motherboard.
- It is recommended that M.2 SATA SSDs be used as boot-only devices.
- The SATA M.2 drives can boot in UEFI mode only. Legacy boot mode is not supported.

**Table 19 M.2 SATA SSDs**

Product ID (PID)	PID Description
UCSX-M2-240G-D	240GB 2.5in M.2 SATA Micron G2 SSD
UCSX-M2-480G-D	480GB 2.5in M.2 SATA Micron G2 SSD
UCSX-M2-960G-D	960GB 2.5in M.2 SATA Micron G2 SSD
UCSX-M2-I240GB-D	240GB SATA M.2 SSD
UCSX-M2-I480GB-D	480GB SATA M.2 SSD

**STEP 11 ORDER NVMe BOOT (OPTIONAL)**

Table 20 NVMe BOOT

Product ID (PID)	PID Description
UCSX-M2-PT-FPN	UCSX Front Panel w/M.2 Pass Through Controller for NVMe Drv

Table 21 M.2 NVMe

Product ID (PID)	PID Description
UCSX-NVM2-400GB	400GB M.2 Boot NVMe
UCSX-NVM2-960GB	960GB M.2 Boot NVMe

## STEP 12 CHOOSE OPTIONAL TRUSTED PLATFORM MODULE

Trusted Platform Module (TPM) is a computer chip or microcontroller that can securely store artifacts used to authenticate the platform or Cisco UCS X410c M7 Compute Node. These artifacts can include passwords, certificates, or encryption keys. A TPM can also be used to store platform measurements that help ensure that the platform remains trustworthy. Authentication (ensuring that the platform can prove that it is what it claims to be) and attestation (a process helping to prove that a platform is trustworthy and has not been breached) are necessary steps to ensure safer computing in all environments.

Table 22 Available TPM Option

Product ID (PID)	Description
UCSX-TPM-002C-D	TPM 2.0, TCG, FIPS140-2, CC EAL4+ Certified, for servers
UCSX-TPM-OPT-OUT <sup>1</sup>	OPT OUT, TPM 2.0, TCG, FIPS140-2, CC EAL4+ Certified

**Notes:**

1. Please note Microsoft certification requires a TPM 2.0 for bare-metal or guest VM deployments. Opt-out of the TPM 2.0 voids the Microsoft certification.



**NOTE:**

- The TPM module used in this system conforms to TPM v2.0 as defined by the Trusted Computing Group (TCG).
- TPM installation is supported after-factory. However, a TPM installs with a one-way screw and cannot be replaced, upgraded, or moved to another compute node. If a Cisco UCS X410c M7 Compute Node with a TPM is returned, the replacement Cisco UCS X410c M7 Compute Node must be ordered with a new TPM. If there is no existing TPM in the Cisco UCS X410c M7 Compute Node, you can install a TPM 2.0. Refer to the following document for Installation location and instructions:

[https://www.cisco.com/content/en/us/td/docs/unified\\_computing/ucs/x/hw/x410c-m7/install/b-cisco-ucs-x410c-m7-install-guide.html](https://www.cisco.com/content/en/us/td/docs/unified_computing/ucs/x/hw/x410c-m7/install/b-cisco-ucs-x410c-m7-install-guide.html)



## STEP 13 CHOOSE OPERATING SYSTEM AND VALUE-ADDED SOFTWARE

- Operating System ([Table 23](#))



### NOTE:

- See this link for operating system guidance:  
<https://ucshcltool.cloudapps.cisco.com/public/>

Table 23 Operating System

Product ID (PID)	PID Description
<b>Microsoft Windows Server</b>	
MSWS-22-ST16CD	Windows Server 2022 Standard (16 Cores/2 VMs)
MSWS-22-ST16CD-NS	Windows Server 2022 Standard (16 Cores/2 VMs) - No Cisco SVC
MSWS-22-DC16CD	Windows Server 2022 Data Center (16 Cores/Unlimited VMs)
MSWS-22-DC16CD-NS	Windows Server 2022 DC (16 Cores/Unlim VMs) - No Cisco SVC
MSWS-19-ST16CD	Windows Server 2019 Standard (16 Cores/2 VMs)
MSWS-19-ST16CD-NS	Windows Server 2019 Standard (16 Cores/2 VMs) - No Cisco SVC
MSWS-19-DC16CD	Windows Server 2019 Data Center (16 Cores/Unlimited VMs)
MSWS-19-DC16CD-NS	Windows Server 2019 DC (16 Cores/Unlim VMs) - No Cisco SVC
<b>Red Hat</b>	
RHEL-2S2V-D1A	Red Hat Enterprise Linux (1-2 CPU,1-2 VN); 1-Yr Support Req
RHEL-2S2V-D3A	Red Hat Enterprise Linux (1-2 CPU,1-2 VN); 3-Yr Support Req
RHEL-2S2V-D5A	Red Hat Enterprise Linux (1-2 CPU,1-2 VN); 5-Yr Support Req
RHEL-VDC-2SUV-D1A	RHEL for Virt Datacenters (1-2 CPU, Unlim VN) 1 Yr Supp Req
RHEL-VDC-2SUV-D3A	RHEL for Virt Datacenters (1-2 CPU, Unlim VN) 3 Yr Supp Req
RHEL-VDC-2SUV-D5A	RHEL for Virt Datacenters (1-2 CPU, Unlim VN) 5 Yr Supp Req
<b>Red Hat Ent Linux/ High Avail/ Res Strg/ Scal</b>	
RHEL-2S2V-D1S	Red Hat Enterprise Linux (1-2 CPU,1-2 VN); Prem 1Yr SnS Reqd
RHEL-2S2V-D3S	Red Hat Enterprise Linux (1-2 CPU,1-2 VN); Prem 3Yr SnS Reqd
RHEL-2S-HA-D1S	RHEL High Availability (1-2 CPU); Premium 1-yr SnS Reqd
RHEL-2S-HA-D3S	RHEL High Availability (1-2 CPU); Premium 3-yr SnS Reqd
RHEL-2S-RS-D1S	RHEL Resilent Storage (1-2 CPU); Premium 1-yr SnS Reqd
RHEL-2S-RS-D3S	RHEL Resilent Storage (1-2 CPU); Premium 3-yr SnS Reqd

Table 23 Operating System (*continued*)

Product ID (PID)	PID Description
RHEL-VDC-2SUV-D1S	RHEL for Virt Datacenters (1-2 CPU, Unlim VN) 1 Yr SnS Reqd
RHEL-VDC-2SUV-D3S	RHEL for Virt Datacenters (1-2 CPU, Unlim VN) 3 Yr SnS Reqd
<b>Red Hat SAP</b>	
RHEL-SAP-2S2V-D1S	RHEL for SAP Apps (1-2 CPU, 1-2 VN); Prem 1-Yr SnS Reqd
RHEL-SAP-2S2V-D3S	RHEL for SAP Apps (1-2 CPU, 1-2 VN); Prem 3-Yr SnS Reqd
RHEL-SAPSP-D3S	RHEL SAP Solutions Premium - 3 Years
RHEL-SAPSS-D3S	RHEL SAP Solutions Standard - 3 Years
<b>SUSE</b>	
SLES-2S2V-D1A	SUSE Linux Enterprise Svr (1-2 CPU,1-2 VM); 1-Yr Support Req
SLES-2S2V-D3A	SUSE Linux Enterprise Svr (1-2 CPU,1-2 VM); 3-Yr Support Req
SLES-2S2V-D5A	SUSE Linux Enterprise Svr (1-2 CPU,1-2 VM); 5-Yr Support Req
SLES-2SUVM-D1A	SUSE Linux Enterprise Svr (1-2 CPU,Unl VM) LP; 1Y Supp Req
SLES-2SUVM-D3A	SUSE Linux Enterprise Svr (1-2 CPU,Unl VM) LP; 3Y Supp Req
SLES-2SUVM-D5A	SUSE Linux Enterprise Svr (1-2 CPU,Unl VM) LP; 5Y Supp Req
SLES-2S-LP-D1A	SUSE Linux Live Patching Add-on (1-2 CPU); 1yr Support Req
SLES-2S-LP-D3A	SUSE Linux Live Patching Add-on (1-2 CPU); 3yr Support Req
SLES-2S2V-D1S	SUSE Linux Enterprise Svr (1-2 CPU,1-2 VM); Prio 1-Yr SnS
SLES-2S2V-D3S	SUSE Linux Enterprise Svr (1-2 CPU,1-2 VM); Prio 3-Yr SnS
SLES-2S2V-D5S	SUSE Linux Enterprise Svr (1-2 CPU,1-2 VM); Prio 5-Yr SnS
SLES-2SUVM-D1S	SUSE Linux Enterprise Svr (1-2 CPU,Unl VM) LP; Prio 1Y SnS
SLES-2SUVM-D3S	SUSE Linux Enterprise Svr (1-2 CPU,Unl VM) LP; Prio 3Y SnS
SLES-2SUVM-D5S	SUSE Linux Enterprise Svr (1-2 CPU,Unl VM) LP; Prio 5Y SnS
SLES-2S-HA-D1S	SUSE Linux High Availability Ext (1-2 CPU); 1yr SnS
SLES-2S-HA-D3S	SUSE Linux High Availability Ext (1-2 CPU); 3yr SnS
SLES-2S-HA-D5S	SUSE Linux High Availability Ext (1-2 CPU); 5yr SnS
SLES-2S-GC-D1S	SUSE Linux GEO Clustering for HA (1-2 CPU); 1yr Sns
SLES-2S-GC-D3S	SUSE Linux GEO Clustering for HA (1-2 CPU); 3yr SnS
SLES-2S-GC-D5S	SUSE Linux GEO Clustering for HA (1-2 CPU); 5yr SnS
SLES-2S-LP-D1S	SUSE Linux Live Patching Add-on (1-2 CPU); 1yr SnS Required

Table 23 Operating System (*continued*)

Product ID (PID)	PID Description
SLES-2S-LP-D3S	SUSE Linux Live Patching Add-on (1-2 CPU); 3yr SnS Required
<b>SLES and SAP</b>	
SLES-SAP-2S2V-D1S	SLES for SAP Apps (1-2 CPU, 1-2 VM); Priority 1-Yr SnS
SLES-SAP-2S2V-D3S	SLES for SAP Apps (1-2 CPU, 1-2 VM); Priority 3-Yr SnS
SLES-SAP-2S2V-D5S	SLES for SAP Apps (1-2 CPU, 1-2 VM); Priority 5-Yr SnS
SLES-SAP-2S2V-D1A	SLES for SAP Apps w/ HA (1-2 CPU, 1-2 VM); 1-Yr Support Reqd
SLES-SAP-2S2V-D3A	SLES for SAP Apps w/ HA (1-2 CPU, 1-2 VM); 3-Yr Support Reqd
SLES-SAP-2S2V-D5A	SLES for SAP Apps w/ HA (1-2 CPU, 1-2 VM); 5-Yr Support Reqd

## STEP 14 CHOOSE OPTIONAL OPERATING SYSTEM MEDIA KIT

Select the optional operating system media listed in [Table 24](#).

Table 24 OS Media

Product ID (PID)	PID Description
MSWS-19-ST16CD-RM	Windows Server 2019 Stan (16 Cores/2 VMs) Rec Media DVD Only
MSWS-19-DC16CD-RM	Windows Server 2019 DC (16Cores/Unlim VM) Rec Media DVD Only
MSWS-22-ST16CD-RM	Windows Server 2022 Stan (16 Cores/2 VMs) Rec Media DVD Only
MSWS-22-DC16CD-RM	Windows Server 2022 DC (16Cores/Unlim VM) Rec Media DVD Only

# SUPPLEMENTAL MATERIAL

## Simplified Block Diagram

A simplified block diagram of the Cisco UCS X410c M7 Compute Node system board is shown in [Figure 7](#).

Figure 7 Cisco UCS X410c M7 Compute Node Simplified Block Diagram (IFMs 25G with Drives)

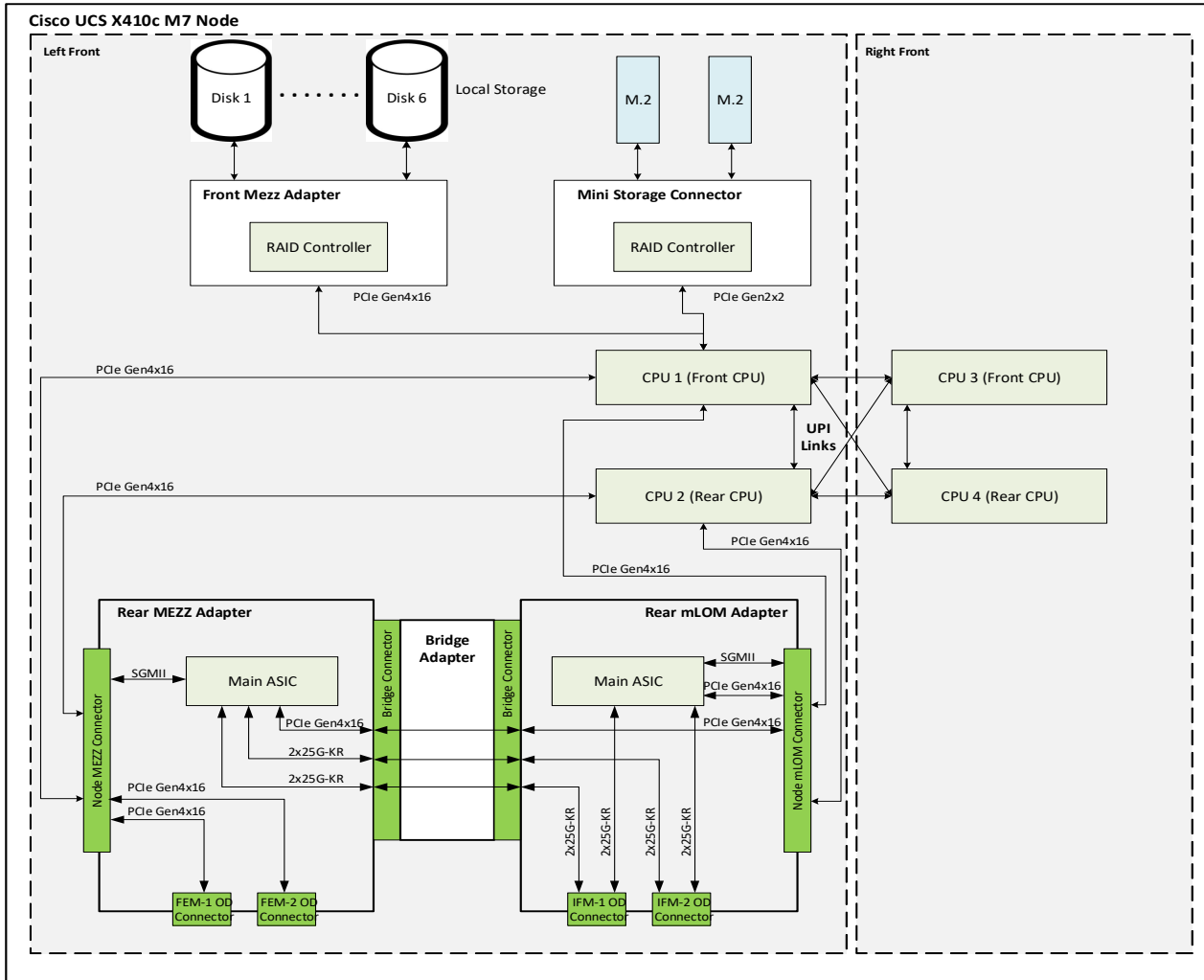
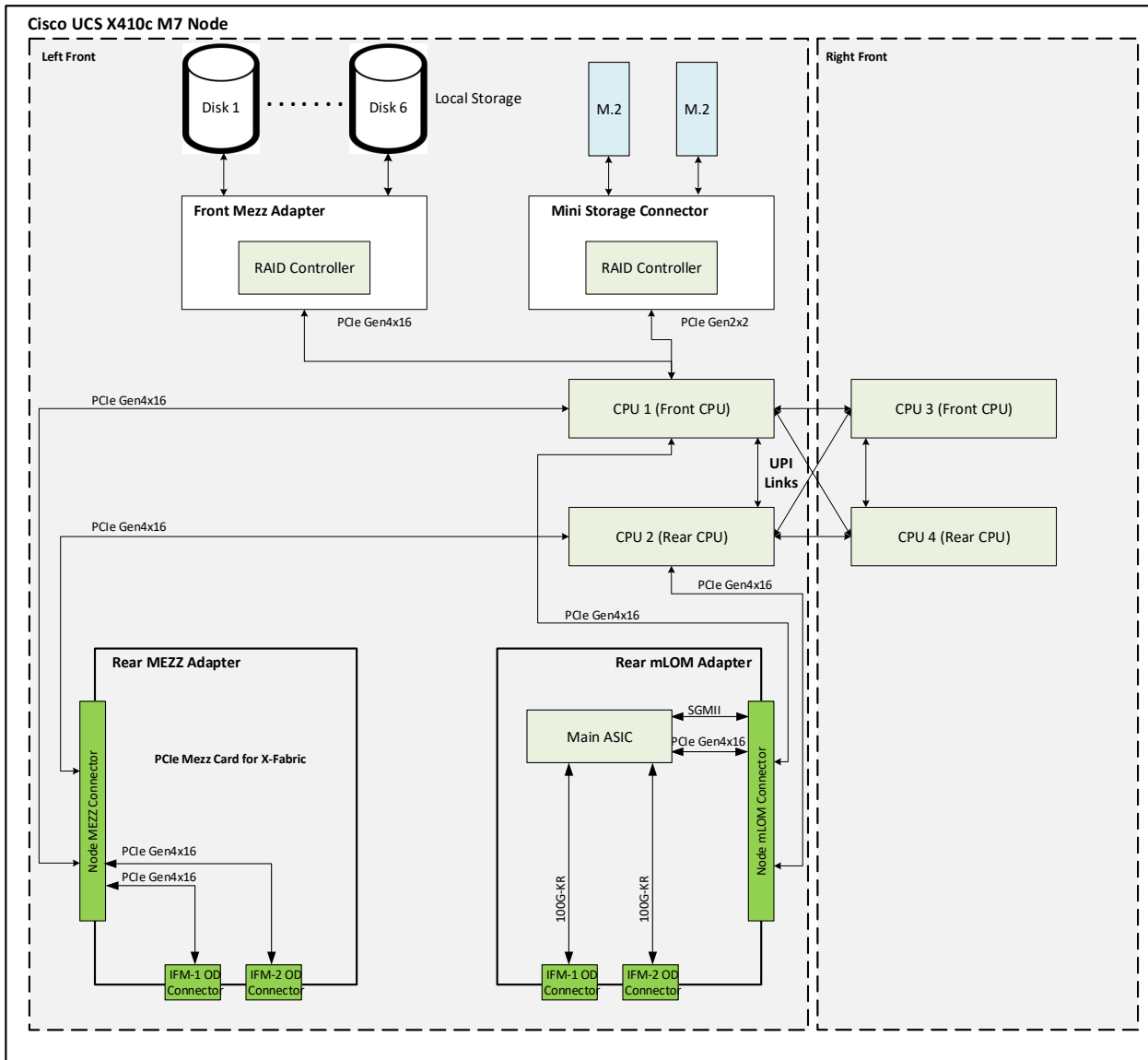

Figure 8 Cisco UCS X410c M7 Compute Node Simplified Block Diagram (IFMs 100G with Drives)



## System Board

A top view of the Cisco UCS X410c M7 Compute Node system board is shown in [Figure 9](#).

Figure 9 Cisco UCS X410c M7 Compute Node System Board

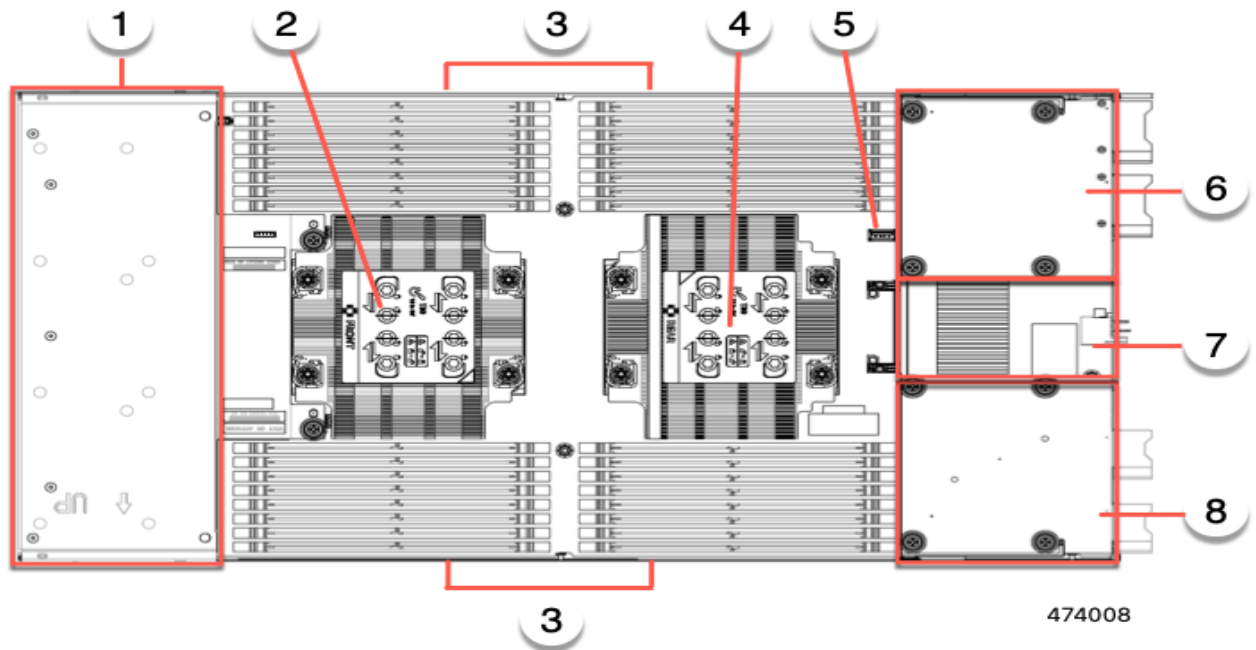

1	Front mezzanine module slot	5	Motherboard USB connector
2	CPU 1 slot	6	Rear mezzanine slot, which supports X-Series mezzanine cards, such as VIC 15422.
3	DIMM slots	7	Bridge Card slot, which connects 8 rear mezzanine slot and the mLOM/VIC slot
4	CPU 2 slot	8	mLOM/VIC slot that supports zero or one Cisco VIC or Cisco X-Series 100 Gbps mLOM

Please refer to the [Cisco UCS X410c M7 Compute Node Installation Guide](#) for installation procedures.



## UPGRADING or REPLACING CPUs and MEMORY

- Refer to [Cisco UCS X410c M7 Server Installation and Service Guide](#) to upgrading or replacing the CPUs
- Refer to [Cisco UCS X410c M7 Server Installation and Service Guide](#) to upgrading or replacing the Memory

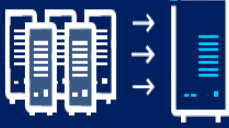

# LEADERSHIP PERFORMANCE WITH 4TH GEN INTEL® XEON® PROCESSORS

Improve performance efficiency for critical workloads with the most built-in accelerators.

<p><b>Accelerate Performance</b></p>  <p>53% general purpose performance gains <sup>1</sup></p> <p>up to 10x increase in AI workload performance with built-in accelerators <sup>2</sup></p>	<p><b>Reduce TCO</b></p>  <p>Up to 5:1 server consolidation with 75% TCO reduction <sup>3</sup></p> <p>3x better efficiency (perf/watt) with built in accelerators <sup>4</sup></p>	<p><b>Increase Security</b></p>  <p><u>Most researched</u> and deployed confidential computing technology in data centers on the market today</p> <p><u>Accelerated data encryption</u> performance with built in accelerators</p>	<p><b>Accelerate Time to Market</b></p>  <p>Extensively tested and validated to <u>run critical workloads at scale</u></p> <p><u>Most choice and flexibility</u> for deployments with largest ecosystem</p>
---	--	---	--

Availability of accelerators varies depending on SKU. Visit the [4th Gen Intel Product Information page](#) for additional product details.

See [Intel® Xeon® Processors Notices and Disclaimers](#) in next page.

## Notes:

1. Compared to prior generation Intel® Xeon® processor. See [G1] at [intel.com/processorclaims](https://intel.com/processorclaims): 4th Gen Intel® Xeon® Scalable processors. Results may vary.
2. Compared to prior generation Intel® Xeon® processor. See [A16] and [A17] at [intel.com/processorclaims](https://intel.com/processorclaims): 4th Gen Intel® Xeon® Scalable processors. Results may vary.
3. Comparing benefits transitioning from Intel® Xeon® 4110 to Intel® Xeon® 5420+. See [E11] at [intel.com/processorclaims](https://intel.com/processorclaims): 4th Gen Intel® Xeon® Scalable processors. Results may vary.
4. Compared to prior generation Intel® Xeon® processor. See [E1] at [intel.com/processorclaims](https://intel.com/processorclaims): 4th Gen Intel® Xeon® Scalable processors. Results may vary.

## Intel® Xeon® Processors Notices and Disclaimers

- Performance varies by use, configuration and other factors.
- Performance results are based on testing as of dates shown in configurations and may not reflect all publicly available updates. See backup for configuration details. No product or component can be absolutely secure.
- Your costs and results may vary.
- Intel technologies may require enabled hardware, software or service activation.
- Intel does not control or audit third-party data. You should consult other sources to evaluate accuracy.
- © Intel Corporation. Intel, the Intel logo, and other Intel marks are trademarks of Intel Corporation or its subsidiaries. Other names and brands may be claimed as the property of others.
- Intel contributes to the development of benchmarks by participating in, sponsoring, and/or contributing technical support to various benchmarking groups, including the BenchmarkXPRT Development Community administered by Principled Technologies.

# TECHNICAL SPECIFICATIONS

## Dimensions and Weight

Table 25 Cisco UCS X410c M7 Compute Node Dimensions and Weight

Parameter	Value
Height	3.67 inches (93.22 mm)
Width	11.28 inches (286.52 mm)
Depth	23.8 inches (604.52 mm)
Weight	The weight depends on the components installed: <ul style="list-style-type: none"> <li>■ Minimally configured compute node weight: 25 lb (11.34 kg)</li> <li>■ Fully configured compute node weight: 42 lb (19.05 kg)</li> </ul>

## Environmental Specifications

Table 26 Cisco UCS X410c M7 Compute Node Environmental Specifications

Parameter	Value
Operating temperature	Supported operating temperatures depend on the compute node's memory: <ul style="list-style-type: none"> <li>■ For 256GB DDR5 DIMMs: 50° to 89.6° F (10° to 32° C) at 0 to 10,000</li> <li>■ All other memory configurations: 50° to 95° F (10° to 35° C) at 0 to 10,000</li> </ul>
Non-operating temperature	-40° to 149° F (-40° to 65° C)
Operating humidity	5% to 90% noncondensing
Non-operating humidity	5% to 93% noncondensing
Operating altitude	0 to 10,000 ft (0 to 3000m); maximum ambient temperature decreases by 1° C per 300m
Non-operating altitude	40,000 ft (12,000m)

For configuration-specific power specifications, use the Cisco UCS Power Calculator at:

<http://ucspowercalc.cisco.com>

## DISCONTINUED EOL PRODUCTS

Below is the list of parts were previously available for this product and are no longer sold. Please refer to the EOL Bulletin Links via table below to determine if still supported.

Table 27 EOS

Product ID	Description	EOL/EOS link
<b>Drives</b>		
UCSX-M2-240GB-D	240GB 2.5in M.2 SATA Micron G1 SSD	<a href="https://www.cisco.com/c/en/us/products/collateral/servers-unified-computing/ucs-c-series-rack-servers/unified-computing-accessories-eol.html">https://www.cisco.com/c/en/us/products/collateral/servers-unified-computing/ucs-c-series-rack-servers/unified-computing-accessories-eol.html</a>
UCSX-M2-960GB-D	960GB 2.5in M.2 SATA Micron G1 SSD	<a href="https://www.cisco.com/c/en/us/products/collateral/servers-unified-computing/ucs-c-series-rack-servers/unified-computing-accessories-eol.html">https://www.cisco.com/c/en/us/products/collateral/servers-unified-computing/ucs-c-series-rack-servers/unified-computing-accessories-eol.html</a>
UCSX-SD76TM1XEVD	7.6TB 2.5in Enter Value 6G SATA Micron G1 SSD	<a href="https://www.cisco.com/c/en/us/products/collateral/servers-unified-computing/ucs-c-series-rack-servers/unified-computing-accessories-eol.html">https://www.cisco.com/c/en/us/products/collateral/servers-unified-computing/ucs-c-series-rack-servers/unified-computing-accessories-eol.html</a>
UCSXSD240GM1XEVD	240GB 2.5in Enter Value 6G SATA Micron G1 SSD	<a href="https://www.cisco.com/c/en/us/products/collateral/servers-unified-computing/ucs-c-series-rack-servers/unified-computing-accessories-eol.html">https://www.cisco.com/c/en/us/products/collateral/servers-unified-computing/ucs-c-series-rack-servers/unified-computing-accessories-eol.html</a>
UCSXSD480GM1XEVD	480 GB 2.5in Enter Value 6G SATA Micron G1 SSD	<a href="https://www.cisco.com/c/en/us/products/collateral/servers-unified-computing/ucs-c-series-rack-servers/unified-computing-accessories-eol.html">https://www.cisco.com/c/en/us/products/collateral/servers-unified-computing/ucs-c-series-rack-servers/unified-computing-accessories-eol.html</a>
UCSX-SD16TM1XEVD	1.6TB 2.5in Enter Value 6G SATA Micron G1 SSD	<a href="https://www.cisco.com/c/en/us/products/collateral/servers-unified-computing/ucs-c-series-rack-servers/unified-computing-accessories-eol.html">https://www.cisco.com/c/en/us/products/collateral/servers-unified-computing/ucs-c-series-rack-servers/unified-computing-accessories-eol.html</a>
UCSX-SD38TM1XEVD	3.8TB 2.5in Enter Value 6G SATA Micron G1 SSD	<a href="https://www.cisco.com/c/en/us/products/collateral/servers-unified-computing/ucs-c-series-rack-servers/unified-computing-accessories-eol.html">https://www.cisco.com/c/en/us/products/collateral/servers-unified-computing/ucs-c-series-rack-servers/unified-computing-accessories-eol.html</a>
UCSX-NVME-W6400-D	6.4TB 2.5in U.2 WD SN840 NVMe Extreme Perf. High Endurance	<a href="https://www.cisco.com/c/en/us/products/collateral/servers-unified-computing/ucs-c-series-rack-servers/unified-computing-accessories-eol.html">https://www.cisco.com/c/en/us/products/collateral/servers-unified-computing/ucs-c-series-rack-servers/unified-computing-accessories-eol.html</a>
UCSX-SD32TK3XEP-D	3.2TB 2.5in Enter Perf 12G SAS Kioxia G1 SSD (3X)	<a href="https://www.cisco.com/c/en/us/products/collateral/servers-unified-computing/ucs-b-series-blade-servers/select-ucs-accessories-eol.html">https://www.cisco.com/c/en/us/products/collateral/servers-unified-computing/ucs-b-series-blade-servers/select-ucs-accessories-eol.html</a>
UCSX-SD38TK1XEVD	3.8TB 2.5in Enter Value 12G SAS Kioxia G1 SSD	<a href="https://www.cisco.com/c/en/us/products/collateral/servers-unified-computing/ucs-b-series-blade-servers/select-ucs-accessories-eol.html">https://www.cisco.com/c/en/us/products/collateral/servers-unified-computing/ucs-b-series-blade-servers/select-ucs-accessories-eol.html</a>
UCSX-SD76TBKNK9-D	7.6TB 2.5in Enter Value 12G SAS Kioxia G1 SSD (SED-FIPS)	<a href="https://www.cisco.com/c/en/us/products/collateral/servers-unified-computing/ucs-b-series-blade-servers/select-ucs-accessories-eol.html">https://www.cisco.com/c/en/us/products/collateral/servers-unified-computing/ucs-b-series-blade-servers/select-ucs-accessories-eol.html</a>
UCSX-SD76TK1XEVD	7.6TB 2.5in Enter Value 12G SAS Kioxia G1 SSD	<a href="https://www.cisco.com/c/en/us/products/collateral/servers-unified-computing/ucs-b-series-blade-servers/select-ucs-accessories-eol.html">https://www.cisco.com/c/en/us/products/collateral/servers-unified-computing/ucs-b-series-blade-servers/select-ucs-accessories-eol.html</a>
UCSXNVMEI4I6400-D	6.4TB 2.5in U.2 Intel P5600 NVMe High Perf High Endurance	<a href="https://www.cisco.com/c/en/us/products/collateral/servers-unified-computing/ucs-b-series-blade-servers/select-ucs-accessories-eol.html">https://www.cisco.com/c/en/us/products/collateral/servers-unified-computing/ucs-b-series-blade-servers/select-ucs-accessories-eol.html</a>
UCSX-SD16TBKNK9-D	1.6TB 2.5in Enter Perf 12G SAS Kioxia G1 SSD (3X SED-FIPS)	<a href="https://www.cisco.com/c/en/us/products/collateral/servers-unified-computing/ucs-b-series-blade-servers/select-ucs-accessories-eol.html">https://www.cisco.com/c/en/us/products/collateral/servers-unified-computing/ucs-b-series-blade-servers/select-ucs-accessories-eol.html</a>

Table 27 EOS

UCSX-SD16TK3XEP-D	1.6TB 2.5in Enter Perf 12G SAS Kioxia G1 SSD (3X)	<a href="https://www.cisco.com/c/en/us/products/collateral/servers-unified-computing/ucs-b-series-blade-servers/select-ucs-accessories-eol.html">https://www.cisco.com/c/en/us/products/collateral/servers-unified-computing/ucs-b-series-blade-servers/select-ucs-accessories-eol.html</a>
UCSX-SD19TK1XEV-D	1.9TB 2.5in Enter Value 12G SAS Kioxia G1 SSD	<a href="https://www.cisco.com/c/en/us/products/collateral/servers-unified-computing/ucs-b-series-blade-servers/select-ucs-accessories-eol.html">https://www.cisco.com/c/en/us/products/collateral/servers-unified-computing/ucs-b-series-blade-servers/select-ucs-accessories-eol.html</a>
UCSXSD38T6S1XEV-D	3.8TB 2.5in Enter Value 6G SATA Samsung SSD	<a href="https://www.cisco.com/c/en/us/products/collateral/servers-unified-computing/ucs-c-series-rack-servers/select-ucs-hci-accessories-eol.html">https://www.cisco.com/c/en/us/products/collateral/servers-unified-computing/ucs-c-series-rack-servers/select-ucs-hci-accessories-eol.html</a>
UCSXSD38T6S1XEV-D	3.8TB 2.5in Enter Value 6G SATA Samsung SSD	<a href="https://www.cisco.com/c/en/us/products/collateral/servers-unified-computing/ucs-c-series-rack-servers/select-ucs-hci-accessories-eol.html">https://www.cisco.com/c/en/us/products/collateral/servers-unified-computing/ucs-c-series-rack-servers/select-ucs-hci-accessories-eol.html</a>
UCSXS960G6S1XEV-D	960GB 2.5 inch Enterprise Value 6G SATA Samsung SSD	<a href="https://www.cisco.com/c/en/us/products/collateral/servers-unified-computing/ucs-c-series-rack-servers/select-ucs-accessories-eol15371.html">https://www.cisco.com/c/en/us/products/collateral/servers-unified-computing/ucs-c-series-rack-servers/select-ucs-accessories-eol15371.html</a>





---

**Americas Headquarters**

Cisco Systems, Inc.  
San Jose, CA

**Asia Pacific Headquarters**

Cisco Systems (USA) Pte. Ltd.  
Singapore

**Europe Headquarters**

Cisco Systems International BV Amsterdam,  
The Netherlands

---

Cisco has more than 200 offices worldwide. Addresses, phone numbers, and fax numbers are listed on the Cisco Website at [www.cisco.com/go/offices](http://www.cisco.com/go/offices).

---

Cisco and the Cisco Logo are trademarks of Cisco Systems, Inc. and/or its affiliates in the U.S. and other countries. A listing of Cisco's trademarks can be found at [www.cisco.com/go/trademarks](http://www.cisco.com/go/trademarks). Third party trademarks mentioned are the property of their respective owners. The use of the word partner does not imply a partnership relationship between Cisco and any other company. (1005R)