



Cisco UCS C4200 Series Rack Server Chassis with UCS C125 M5 Rack Server Node

CONTENTS

OVERVIEW	3
DETAILED VIEWS	4
Chassis Front View	.4
Chassis Rear View	.5
Serviceable Components in the Chassis	.6
BASE SERVER STANDARD CAPABILITIES and FEATURES	8
CONFIGURING the SERVER	10
STEP 1 VERIFY SERVER CHASSIS SKU	11
STEP 2 SELECT SERVER NODE	12
STEP 3 SELECT CPU(s)	13
STEP 4 SELECT MEMORY	15
STEP 5 SELECT RAID CONTROLLERS	16
RAID Controller Options	16
STEP 6 SELECT HARD DISK DRIVES (HDDs) or SOLID STATE DRIVES (SSDs)	18
STEP 7 SELECT PCIe OPTION CARD(s)	21
STEP 8 ORDER OPTIONAL PCIe OPTION CARD ACCESSORIES	23
STEP 9 ORDER M.2 SATA SSD (OPTIONAL)	24
STEP 10 ORDER SD CARD MODULE (OPTIONAL)	25
STEP 11 ORDER MICRO-SD CARD MODULE (OPTIONAL)	26
STEP 12 ORDER OPTIONAL USB 3.0 DRIVE	27
STEP 13 ORDER SECURITY DEVICES (OPTIONAL)	28
STEP 14 SELECT LOCKING SECURITY BEZEL (OPTIONAL)	29
STEP 15 SELECT POWER SUPPLY	30
STEP 16 SELECT POWER CORD(s)	31
STEP 17 SELECT TOOL-LESS RAIL KIT AND OPTIONAL REVERSIBLE CABLE MANAGEMENT ARM	32
STEP 18 SELECT A KVM CABLE (OPTIONAL)	33
STEP 19 SELECT OPERATING SYSTEM AND VALUE-ADDED SOFTWARE	34
STEP 20 SELECT OPERATING SYSTEM MEDIA KIT	36
STEP 21 SELECT SERVICE and SUPPORT LEVEL	37
SUPPLEMENTAL MATERIAL	43
CHASSIS	43
BLOCK DIAGRAM	44
CPUs and DIMMs	45
DIMM Sockets	46
Memory Population Rules	47
DIMM Population Rules	47
Upgrade and Servicing-Related Parts	49
TECHNICAL SPECIFICATIONS	50
Dimensions and Weight	50
Power Specifications	51
Environmental Specifications	52
Compliance Requirements	53
DISCONTINUED EOL PRODUCTS	54

OVERVIEW

The Cisco UCS C4200 Series Rack Server Chassis is a modular, dense rack server chassis that supports up to four UCS C125 M5 Rack Server Nodes, optimized for use in environments requiring dense compute form factor and high core densities such as scale-out/compute intensive, general service provider, and bare-metal applications.

The Cisco UCS C4200 chassis is a modular architecture consisting of the following modules:

- **Base Chassis:** 24 SFF drive bays segmented into four groups of six direct attach drives (one group per node slot), four rear slots supporting C125 M5 server node, four redundant hot-pluggable fans, two 2400W AC high-line redundant power supplies, and a rail mounting kit.
- **Server Node:** Each C125 M5 has two sockets supporting the AMD EPYC™ 7000 Processors up to 180W TDP, 16 DIMM slots for 2666 MHz DDR4 DIMMs and capacity points up to 64GB, up to 2 half-height/half-length PCI Express (PCIe) 3.0 slots, and optional M.2/SD module. The C125 supports either SAS RAID via a PCIe 12G SAS storage controller card or SATA direct from the AMD EPYC™ CPU. The node also includes a dedicated internal LAN mezzanine slot based on the OCP 2.0 standard supporting networking speeds up to 100Gbps. Additionally installation of a 4th generation Cisco PCIe Virtual Interface Card (VIC) can be added in the x16 PCIe 3.0 slot.

The Cisco UCS C4200 can be used standalone, or as part of the Cisco Unified Computing System, which unifies computing, networking, management, virtualization, and storage access into a single integrated architecture enabling end-to-end server visibility, management, and control in both bare metal and virtualized environments.

Figure 1 Cisco UCS C4200 Storage Server

Front View



Rear View



DETAILED VIEWS

Chassis Front View

Figure 2 shows the Cisco UCS C4200.

Figure 2 Chassis Front View

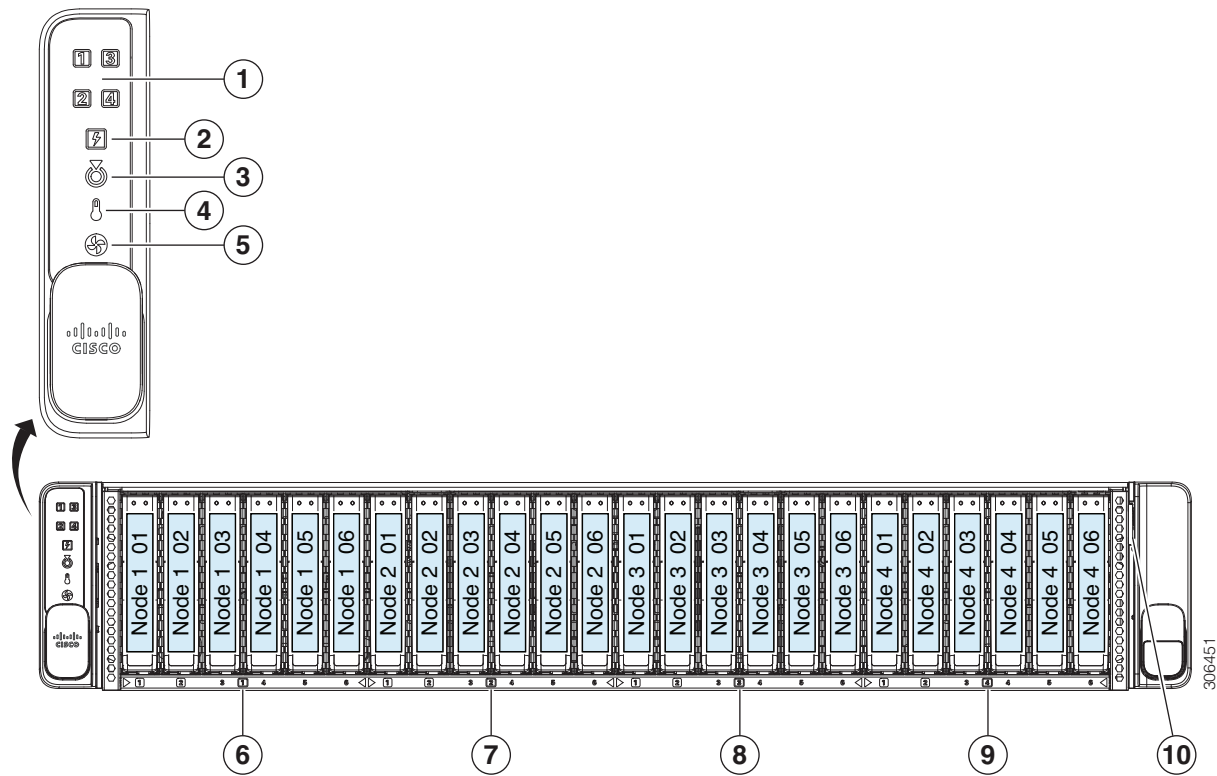

1	Node Health LEDs	6	Node 1-controlled drive bays 1–6
2	Power Supply Status LED	7	Node 2-controlled drive bays 1–6
3	Locator beacon LED Activating the locator beacon of any installed compute node activates this chassis locator beacon	8	Node 3-controlled drive bays 1–6
4	Temperature status LED	9	Node 4-controlled drive bays 1–6
5	Fan status LED	10	Pull-out asset tag

Chassis Rear View

Figure 4 shows the external features of the rear of the C4200 chassis with four C125 M5 server node (Epyc CPUs) installed.

Figure 3 Chassis Rear View

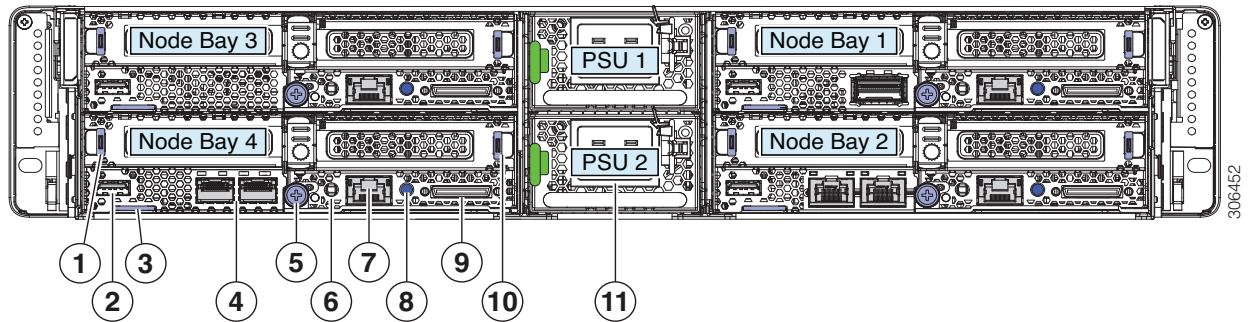

1	PCIe riser 1 handle (one each node)	7	Node 1 Gb Ethernet dedicated management port (one each node)
2	Node USB 3.0 port (one each node)	8	Node locator button/LED (one each node)
3	Node pull-out asset tag (one each node)	9	Node KVM local debug console port (one each node) Used with KVM cable that provides one DB-15 VGA, one DB-9 serial, and two USB 2.0 connectors.
4	Node OCP adapter card Ethernet LAN ports (one each node, if this optional adapter card is installed) Depending on which adapter card is installed, these ports can be either: <ul style="list-style-type: none"> ■ Dual 10 Gb Base-T (RJ-45 connectors) ■ Dual 10/25 Gb SFP28 	10	PCIe slots (two horizontal slots each node) <ul style="list-style-type: none"> ■ Node PCIe riser 1/slot 1 (on left) (half-height, half length, x8 slot) ■ Node PCIe riser 2/slot 2 (on right) (half-height, half length, x16 slot)
5	Node securing thumbscrew and release lever (one each node)	11	Chassis power supplies (two, redundant 1+1)
6	Node Power button/Power status LED (one each node)	–	

Serviceable Components in the Chassis

The figure in this topic shows the locations of the serviceable components in the chassis.

For components inside a compute node, see the service note for your compute node: Cisco UCS C125 M5 Rack Server Node for Cisco UCS C4200 Rack Server Chassis Service Note.

https://www.cisco.com/c/en/us/td/docs/unified_computing/ucs/c/hw/C125/install/C125.html

Figure 4 Cisco UCS C4200 Chassis Serviceable Component Locations

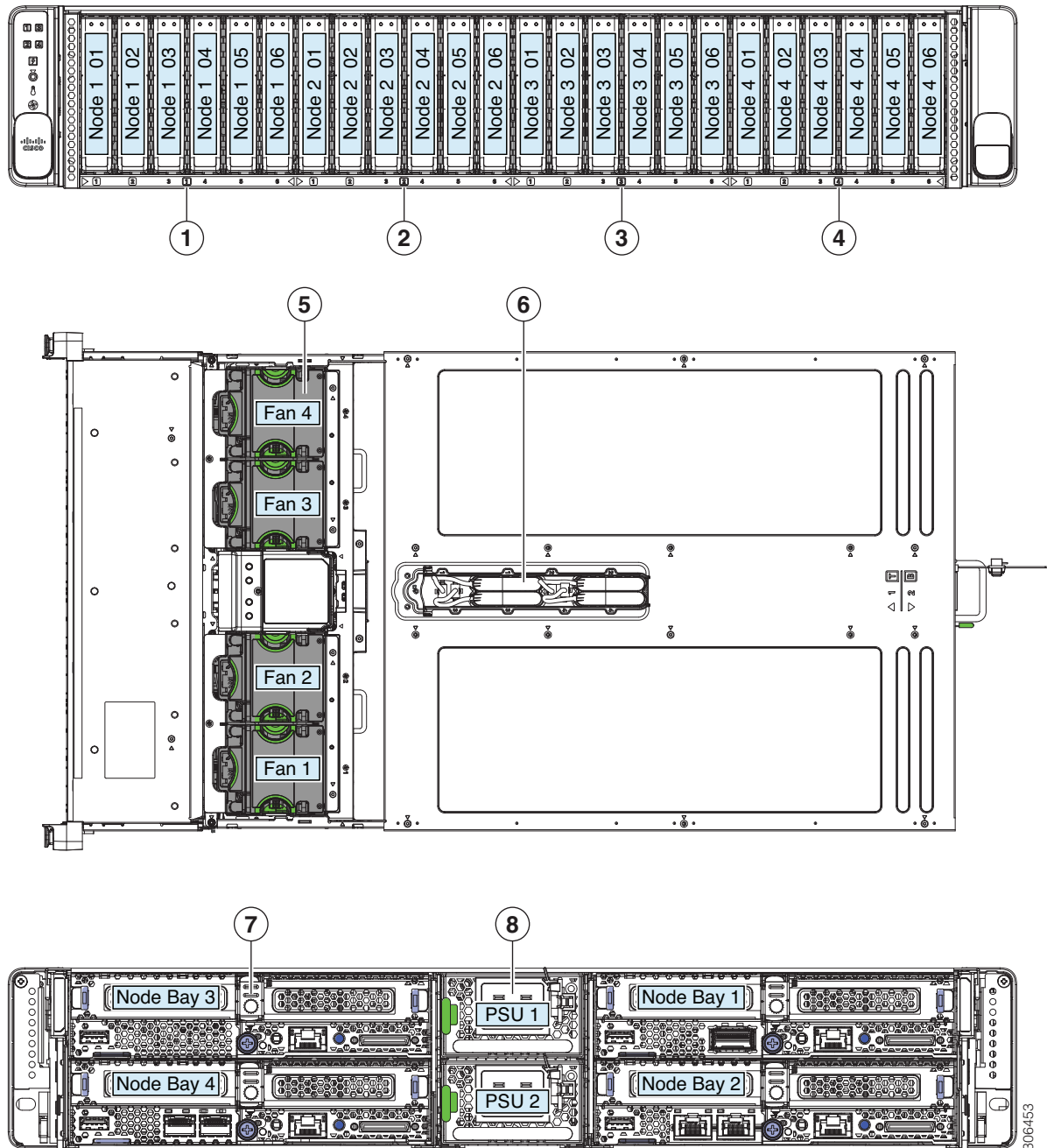

1	Front-loading drives Node 1-controlled drive bays 1–6	5	Cooling fan modules (four)
2	Front-loading drives Node 2-controlled drive bays 1–6	6	Supercap units (RAID backup) Each supercap unit backs up one RAID controller in the corresponding node (numbered 1–4)
3	Front-loading drives Node 3-controlled drive bays 1–6	7	Compute node (up to four)
4	Front-loading drives Node 4-controlled drive bays 1–6	8	Power supplies (two, redundant 1+1)

BASE SERVER STANDARD CAPABILITIES and FEATURES

Table 1 lists the capabilities and features of the base server. Details about how to configure the server for a particular feature or capability (for example, number of processors, disk drives, or amount of memory) are provided in *CONFIGURING the SERVER, page 10*.

Table 1 Capabilities and Features

Capability/Feature	Description
Chassis	Two rack-unit (2RU) chassis
Central Processor	The chassis supports two to four removable UCS C125 M5 nodes, each with two CPUs. With four nodes, the system can total up to eight CPUs from the AMD EPYC™ 7000 Series up to 180W TDP.
Memory	The chassis supports two to four removable UCS C125 M5 nodes, each with two CPUs. Each CPU supports up to eight DIMMs. With four nodes, the system can have a total up to 64 DIMMs.
Multi-bit error protection	Multi-bit error protection is supported
Baseboard management	Each UCS C125 M5 node has a BMC, running Cisco Integrated Management Controller (Cisco IMC) firmware. Depending on your settings, Cisco IMC can be accessed on each node through its 1-Gb dedicated management port or an adapter card.
Network and management I/O	The network and management I/O ports for this chassis are on the removable compute nodes. Each compute node has these connectors accessible from the rear of the chassis: <ul style="list-style-type: none"> ■ One 10/100/1000 Ethernet dedicated management port (RJ-45 connector) ■ One keyboard/video/mouse (KVM) console connector that is used with a KVM cable, which provides two USB 2.0, one DB-15 VGA, and one DB-9 serial connector. ■ One USB 3.0 port ■ Optional OCP adapter-card Ethernet LAN ports. Depending on which adapter is installed, these ports can be: <ul style="list-style-type: none"> • Dual 10 Gb BASE-T (RJ-45 connectors) • Dual 10/25 Gb SFP28
Power	Two power supplies, redundant as 1+1: <ul style="list-style-type: none"> ■ AC power supplies 2400 W AC each Do not mix power supply types or wattages in the server.
ACPI	The advanced configuration and power interface (ACPI) 4.0 standard is supported.
Cooling	Four hot-swappable fan modules for front-to-rear cooling.
PCIe I/O	Each removable compute node has two PCIe risers for horizontal installation of PCIe cards such as a RAID controller or Cisco Virtual Interface Card (VIC).
InfiniBand	The OCP and PCIe bus slots in the compute nodes support the InfiniBand architecture. Check the Cisco HCL for more information.
Storage, front-panel	The chassis can hold up to 24 front-loading, 2.5-inch drives. Each of the four removable compute nodes can control six of the front drives.

Capability/Feature	Description
Storage, internal	Each of the four compute nodes have these internal storage options: <ul style="list-style-type: none">■ Mini-storage module socket, optionally with either:<ul style="list-style-type: none">• SD card carrier. Supports up to two SD cards• M.2 SSD carrier. Supports two SATA M.2 SSDs■ One micro-SD card socket.
Storage management	Each of the four compute nodes support one RAID controller card. Each node can control six of the front-panel drives.
RAID supercap backup	Up to four supercap units are supported one for the RAID controller card in each node. The supercap units have numbered bays and numbered cable connectors in the top of the chassis, corresponding to each numbered compute node.
Integrated video	Integrated VGA video in each compute node. The DB-15 VGA connector is on the KVM cable that can be used with the KVM connector on each node.

CONFIGURING the SERVER

Follow these steps to configure the Cisco UCS C4200 Storage Server:

- *STEP 1 VERIFY SERVER CHASSIS SKU, page 11*
- *STEP 2 SELECT SERVER NODE, page 12*
- *STEP 3 SELECT CPU(s), page 13*
- *STEP 4 SELECT MEMORY, page 14*
- *STEP 5 SELECT RAID CONTROLLERS, page 15*
- *STEP 6 SELECT HARD DISK DRIVES (HDDs) or SOLID STATE DRIVES (SSDs), page 17*
- *STEP 7 SELECT PCIe OPTION CARD(s), page 20*
- *STEP 8 ORDER OPTIONAL PCIe OPTION CARD ACCESSORIES, page 22*
- *STEP 10 ORDER SD CARD MODULE (OPTIONAL), page 24*
- *STEP 11 ORDER MICRO-SD CARD MODULE (OPTIONAL), page 25*
- *STEP 12 ORDER OPTIONAL USB 3.0 DRIVE, page 26*
- *STEP 13 ORDER SECURITY DEVICES (OPTIONAL), page 27*
- *STEP 14 SELECT LOCKING SECURITY BEZEL (OPTIONAL), page 28*
- *STEP 15 SELECT POWER SUPPLY, page 29*
- *STEP 16 SELECT POWER CORD(s), page 30*
- *STEP 17 SELECT TOOL-LESS RAIL KIT AND OPTIONAL REVERSIBLE CABLE MANAGEMENT ARM, page 31*
- *STEP 18 SELECT A KVM CABLE (OPTIONAL), page 32*
- *STEP 19 SELECT OPERATING SYSTEM AND VALUE-ADDED SOFTWARE, page 33*
- *STEP 20 SELECT OPERATING SYSTEM MEDIA KIT, page 35*
- *STEP 21 SELECT SERVICE and SUPPORT LEVEL, page 36*
- *SUPPLEMENTAL MATERIAL, page 42*

STEP 1 VERIFY SERVER CHASSIS SKU

Select the base server product ID (PID) from [Table 2](#).

Table 2 PID of the Cisco UCS C4200 Base Server Chassis

Product ID (PID)	Description
UCSC-C4200-SFF	Cisco UCS C4200 Rack Server Chassis, one rail kit, and bezel.

The Cisco UCS C4200 Multi-node Server:

- Does not include internal storage drives, power supplies, or compute nodes (no CPU, memory, or Storage controller).



NOTE:

- Use the steps on the following pages to configure the server with the components that you want to include.
- The C4200 will support a minimum of two up to a maximum of four C125 M5 server nodes

STEP 2 SELECT SERVER NODE

UCS C125 M5 Rack Server Node (with AMD EPYC™ 7000 CPUs)

This server node is configurable. The base PID of the C125 M5 node is shown [Table 3](#).

Table 3 C125 A1 Server Node Base PID

Product ID (PID)	Description
UCSC-C125	UCS C125 M5 Rack Server Node based on AMD EPYC™ CPUs
UCSC-C125-U	UCS C125 M5 Rack Server Node Standalone Configurable Spare



NOTE:

- The C4200 will support a minimum of two up to a maximum of four C125 M5 server nodes
- If any server node contains two CPU, any GPU and 16x 128GB DIMMs, then the node quantity cannot be greater than 2.

STEP 3 SELECT CPU(s)

Use the following tables to choose options for the C125 M5 rack server node. The C125 M5 supports dual and single socket configurations up to 180W TDP.

Choose two CPUs from [Table 4](#).

Table 4 Dual Socket CPUs

Product ID (PID) ¹	Description ²
UCS-CPU-A7702 ³	AMD 2.0GHz 7702 200W 64C/256MB Cache DDR4 3200MHz
UCS-CPU-A7552 ³	AMD 2.2GHz 7552 200W 48C/192MB Cache DDR4 3200MHz
UCS-CPU-A7532 ³	AMD 2.4GHz 7532 200W 32C/256MB Cache DDR4 3200MHz
UCS-CPU-A7352	AMD 2.3GHz 7352 155W 24C/128MB Cache DDR4 3200MHz
UCS-CPU-A7F32	AMD 3.7GHz 7F32 180W 8C/128MB Cache DDR4 3200MHz
UCS-CPU-A7302	AMD 3.0GHz 7302 155W 16C/128MB Cache DDR4 3200MHz
UCS-CPU-A7272	AMD 2.9GHz 7272 120W 12C/64MB Cache DDR4 3200MHz
UCS-CPU-A7452	AMD 2.35GHz 7452 155W 32C/128MB Cache DDR4 3200MHz
UCS-CPU-A7402	AMD 2.8GHz 7402 180W 24C/128MB Cache DDR4 3200MHz
UCS-CPU-A7262	AMD 3.2GHz 7262 155W 8C/128MB Cache DDR4 3200MHz
UCS-CPU-A7282	AMD 2.8GHz 7282 120W 16C/64MB Cache DDR4 3200MHz

Notes:

1. Use the following table to choose a non-upgradeable single socket only configuration for the UCS C125 M5 server node. These PIDs cannot be used with a second processor, if your customer wants to upgrade to a second processor in the future it is recommended to use one the PIDs in [Table 4](#)
2. Selecting a single socket configuration will disable NVMe drive support. A second processor is required for NVMe
3. Maximum supported TDP of C125 server is 180W. When this CPU is installed in the C125 server it will operate at 180W and its peak performance will be throttled accordingly

STEP 4 SELECT MEMORY

- Choose DIMMs from [Table 5](#).

Table 5 DIMMs

Product ID (PID)	PID Description
UCS-ML-128G4RW	128GB LRDIMM QRx4 3200 (16Gb)
UCS-MR-X64G2RW-M	(16Gb) 64GB 3200MHZ RDIMM
UCS-MR-X32G2RW-M	(8Gb) 32GB 3200MHZ RDIMM
UCS-MR-X16G1RW-M	(8Gb) 16GB 3200MHZ RDIMM



NOTE:

- The AMD EPYC™ 7000 CPU features a high performance 8-channel memory controller. It is recommended to always populate every DIMM slot for best system performance, however if fewer DIMMs are desired a minimum of 4 DIMMs per CPU is generally recommended.
- Unbalanced memory configurations should be avoided.

STEP 5 SELECT RAID CONTROLLERS

RAID Controller Options

Embedded SATA AHCI Controller

The default configuration is embedded SATA AHCI Controller from the Epyc CPU (CPU0) which features no RAID support and supports only SATA HDDs and enterprise value SSDs. A maximum of 6 SATA drives are supported with embedded SATA Controller. When the Embedded SATA controller is used, the PCIe riser 1 slot can be used with other PCIe add-on-cards.

- Choose a storage controller from [Table 6](#)

Table 6 RAID Controller

Product ID (PID)	PID Description
UCSC-RAID-C125KIT	UCS C125 9460-8i RAID kit
UCSC-HBA-C125KIT ¹	UCS C125 9400-8i HBA kit

Notes:

1. Can only be selected with Rome CPU.



CAUTION: Always shut down the node before removing it from the chassis, as described in the user manual. Failure to shut down the node before removal results in the corresponding RAID supercap cache being discarded and other data might be lost.

Table 7 Hardware Controller Options

Product ID (PID)	PID Description
UCSC-RAID-C125KIT	UCS C125 9460-8i RAID kit
UCSC-HBA-C125KIT	UCS C125 9400-8i HBA kit
RAID Configuration Options (not available for embedded SATA controller)	
R2XX-SRAID0	Enable Single Disk Raid 0 Setting
R2XX-RAID0	Factory preconfigured RAID striping option Enable RAID 0 Setting. Requires a minimum of one hard drive.
R2XX-RAID1	Factory preconfigured RAID mirroring option Enable RAID 1 Setting. Requires exactly two drives with the same size, speed, capacity.
R2XX-RAID5	Factory preconfigured RAID option Enable RAID 5 Setting. Requires a minimum of three drives of the same size, speed, capacity.
R2XX-RAID6	Factory preconfigured RAID option Enable RAID 6 Setting. Requires a minimum of four drives of the same size, speed, capacity.

Table 7 Hardware Controller Options (*continued*)

Product ID (PID)	PID Description
R2XX-RAID10	Factory preconfigured RAID option Enable RAID 10 Setting. Requires a minimum of four drives of the same size, speed, capacity.

STEP 6 SELECT HARD DISK DRIVES (HDDs) or SOLID STATE DRIVES (SSDs)

The standard disk drive features are:

- 2.5-inch small form factor
- Hot-pluggable
- Drives come mounted in sleds

Select front-facing Drives

The available drives are listed in [Table 8](#).

Table 8 Available Additional HDDs and SSDs

Product ID (PID)	PID Description	Drive Type	Capacity
HDDs			
UCS-HD600G10KJ4	Cisco UCS C4200 600GB 12Gbps 10K HDD	SAS	600GB
UCS-HD12TB10KJ4	Cisco UCS C4200 1.2TB 12Gbps 10K HDD	SAS	1.2TB
UCS-HD18TB10KJ4	Cisco UCS C4200 1.8TB 12Gbps 10K HDD (4K)	SAS	1.8TB
UCS-HD24TB10KJ4	Cisco UCS C4200 2.4TB 12Gbps 10K HDD (4K)	SAS	2.4TB
Self-Encrypted Drives (SED)¹			
UCS-SD800GBHMK9	Cisco UCS C4200 800GB 12Gbps SSD SED	SAS	800GB
UCS-SD16TBHMK9	Cisco UCS C4200 1.6TB 12Gbps SSD SED	SAS	1.6TB
UCS-SD960GBKNK9	1.6TB 2.5" Enterprise performance 12GSAS SSD(3DWPD,SED-FIPS)	SAS	1.6TB
UCS-SD38TBKNK9	3.8TB 2.5" Enterprise value 12G SAS SSD (1DWPD, SED-FIPS)	SAS	3.2TB
UCS-SD800GBKNK9	800GB 2.5" Enterprise performance 12GSAS SSD(3DWPD,SED-FIPS)	SAS	800GB
UCS-SD16TBKNK9	1.6TB 2.5" Enterprise performance 12G SAS SSD(3DWPD,SED-FIPS)	SAS	1.6TB
UCS-SD960GM2NK9	960GB Enterprise value SATA SSD (1X , SED)	SATA	960GB
UCS-SD76TEM2NK9	7.6TB Enterprise value SATA SSD (1X, SED)	SATA	7.6TB
Enterprise Performance 3X Read			
UCS-SD400G123X-EP	400GB 2.5 inch Enterprise performance 12G SAS SSD(3X endurance)	SAS	400GB
UCS-SD16T123X-EP	1.6TB 2.5 inch Enterprise performance 12G SAS SSD(3X endurance)	SAS	1.6TB
UCS-SD800GK3X-EP	800GB 2.5in Enterprise Performance 12G SAS SSD(3X endurance)	SAS	800GB
UCS-SD32TKA3X-EP	3.2TB 2.5in Enter Perf 12G SAS Kioxia G2 SSD (3X)	SAS	3.2TB
UCS-SD16TK3X-EP	1.6TB 2.5in Enterprise Performance 12G SAS SSD(3X endurance)	SAS	1.6TB
UCS-SD32TK3X-EP	3.2TB 2.5in Enterprise Performance 12G SAS SSD(3X endurance)	SAS	3.2TB
UCS-SD19TBM3X-EP	1.9TB 2.5in Enterprise performance 6GSATA SSD(3X endurance)	SATA	1.9 TB
UCS-SD960GBM3X-EP	960GB 2.5in Enterprise performance 6GSATA SSD(3X endurance)	SATA	960 GB
UCS-SD480GBM3X-EP	480GB 2.5in Enterprise Performance 6GSATA SSD(3X endurance)	SATA	480 GB

Table 8 Available Additional HDDs and SSDs

Product ID (PID)	PID Description	Drive Type	Capacity
Enterprise Value			
UCS-SD76TBM1X-EV	7.6TB 2.5 inch Enterprise Value 6G SATA SSD	SATA	7.6 TB
UCS-SD38TBM1X-EV	3.8TB 2.5 inch Enterprise Value 6G SATA SSD	SATA	3.8 TB
UCS-SD19TBM1X-EV	1.9TB 2.5 inch Enterprise Value 6G SATA SSD	SATA	1.9 TB
UCS-SD16TBM1X-EV	1.6TB 2.5 inch Enterprise Value 6G SATA SSD	SATA	1.6 TB
UCS-SD960GBM1X-EV	960GB 2.5 inch Enterprise Value 6G SATA SSD	SATA	960 GB
UCS-SD480GBM1X-EV	480 GB 2.5 inch Enterprise Value 6G SATA SSD	SATA	480 GB
UCS-SD240GBM1X-EV	240GB 2.5 inch Enterprise Value 6G SATA SSD	SATA	240 GB
UCS-SD120GM1X-EV	Cisco UCS C4200 120GB 6Gbps SSD	SATA	120GB
UCS-SD960GK1X-EV	960GB 2.5 inch Enterprise Value 12G SAS SSD	SAS	960GB
UCS-SD19TK1X-EV	1.9TB 2.5 inch Enterprise Value 12G SAS SSD	SAS	1.9TB
UCS-SD38TK1X-EV	3.8TB 2.5 inch Enterprise Value 12G SAS SSD	SAS	3.8TB
UCS-SD76TK1X-EV	7.6TB 2.5 inch Enterprise Value 12G SAS SSD	SAS	7.6TB
NVMe²			
UCSC-NVMEHW-H3200	Cisco UCS C4200 U.2 3.2TB HGST SN200	NVMe	3.2TB
UCS-NVMEM6-W3200	3.2TB 2.5in U.2 WD SN840 NVMe Extreme Perf. High Endurance	NVMe	3.2 TB
UCS-NVMEM6-W7680	7.6TB 2.5in U.2 WD SN840 NVMe Extreme Perf. Value Endurance	NVMe	7.6 TB
UCS-NVMEM6-W15300	15.3TB 2.5in U.2 WD SN840 NVMe Extreme Perf. High Endurance	NVMe	15.3 TB
UCS-NVME4-1920	1.9TB 2.5in U.2 15mm P5520 Hg Perf Med End NVMe	NVMe	1.9 TB
UCS-NVME4-3840	3.8TB 2.5in U.2 15mm P5520 Hg Perf Med End NVMe	NVMe	3.8 TB
UCS-NVME4-7680	7.6TB 2.5in U.2 15mm P5520 Hg Perf Med End NVMe	NVMe	7.6 TB
UCS-NVME4-1536	15.3TB 2.5in U.2 15mm P5520 Hg Perf Med End NVMe	NVMe	15.3 TB
UCS-NVME4-1600	1.6TB 2.5in U.2 15mm P5620 Hg Perf Hg End NVMe (3X)	NVMe	1.6 TB
UCS-NVME4-3200	3.2TB 2.5in U.2 15mm P5620 Hg Perf Hg End NVMe (3X)	NVMe	3.2 TB
UCS-NVME4-6400	6.4TB 2.5in U.2 15mm P5620 Hg Perf Hg End NVMe (3X)	NVMe	6.4 TB
<p>NOTE: Cisco uses solid state drives (SSDs) from a number of vendors. All solid state drives (SSDs) are subject to physical write limits and have varying maximum usage limitation specifications set by the manufacturer. Cisco will not replace any solid state drives (SSDs) that have exceeded any maximum usage specifications set by Cisco or the manufacturer, as determined solely by Cisco.</p>			

Notes:

1. For all self-encrypting drives (SED), standalone Management (CIMC) and UCSM is supported for configuring and managing local keys. SED drives can be managed with local and remote key management (third-party key management).
2. Two CPUs must be installed in order to include any number of SFF NVMe SSDs. If you choose one or two SFF NVMe drives, drive slots 1 and 2 are reserved for these drives (see [Figure 9 on page 45](#) for drive slot numbering)



NOTE: To Add Individual Drives, use the HDD or SSD Tab in CCW

STEP 7 SELECT PCIe OPTION CARD(s)

The standard PCIe card offerings are:

- OCP LAN Module (OCP)
- Network Interface Cards (NICs)
- PCIe Virtual Interface Cards (VICs)
- GPU

Select PCIe Option Cards

The available PCIe option cards are listed in [Table 9](#).

Table 9 Available PCIe Option Cards ¹

Product ID (PID)	PID Description	Form Factor	Electrical Slot
OCP mezzanine			
10 GbE			
UCSC-OCP-QD10GC	Dual Port QL41132HORJ-CI-BK 10Gbase-T OCP 1.0	OCP	N/A
25 GbE			
UCSC-OCP-QD25GF	Qlogic QL41232HOCU Dual Port 25G SFP28 OCP 1.0	OCP	N/A
UCSC-O-ID25GF	Intel XXV710DA2OCP1 2x25/10GbE OCP 2.0	OCP	N/A
100 GbE			
UCSC-O-M5S100GF	Mellanox MCX545B-ECAN 1x100Gb IB/ENET QSFP28 NIC OCP	OCP	N/A
Network Interface Cards (NICs)			
10 GbE			
UCSC-PCIE-IQ10GF	Intel X710 quad-port 10G SFP+ NIC	HHHL	x 8
UCSC-PCIE-QD10GC	QLogic dual-port 10GBase-T QL41162HLRJ-11-SP	HHHL	x 8
25 GbE			
UCSC-PCIE-ID25GF	Intel XXV710-DA2 2x25GbE SFP+ PCIe NIC	HHHL	x 8
UCSC-P-M5D25GF	Mellanox MCX512A-ACAT dual port 10/25G SFP28 NIC	HHHL	x 8
UCSC-PCIE-QD25GF	QLogic dual-port 25G SFP QL41212HLCU-CI-BK	HHHL	x 8
100GbE			
UCSC-P-M5D100GF	MELLANOX CX-5 MCX516A-CDAT 2x100GbE QSFP PCIe NIC	HHHL	x 16
PCIe Virtual Interface Cards (VICs)			
25GbE			
UCSC-PCIE-C25Q-04	Cisco UCS VIC 1455 Quad Port 10/25G SFP28 CNA PCIE	HHHL	

Table 9 Available PCIe Option Cards (*continued*)¹

Product ID (PID)	PID Description	Form Factor	Electrical Slot
100GbE			
UCSC-PCIE-C100-04	Cisco VIC 1495 Dual Port 100G QSFP28 CNA PCIe	HHHL	
HBA			
UCSC-PCIE-QD16GF	Qlogic QLE2692 dual-port 16G Fibre Channel HBA	HHHL	
GPU			
UCSC-GPU-T4-16	NVIDIA T4 PCIe 75W 16GB	HHHL	

Notes:

1. Refer to the Cisco HCL (Hardware Compatibility List) for additional card support including InfiniBand

NOTE:

- Cisco VIC 1495 supports 40/100G.
- Other optics available that support 40G.
- Note that QSFP-40/100-SRBD supported at 100G only.
- For list of supported cables and optics with VIC 1495 refer to the [VIC 1400 series data sheet](#).
- Mixing 1300 and 1400 series VIC and MLOMs configurations is not supported.



NOTE: Supported transceivers and cables for Cisco VIC cards. For the supported list of transceivers and cables for QLogic OCP cards please refer to the QLogic 41000 Series interoperability matrix on the Marvell | Cavium website for more information

STEP 8 ORDER OPTIONAL PCIe OPTION CARD ACCESSORIES

- Cisco Transceiver Module Group (TMG) conducts tests with Cisco optics and cables and publishes the results in the TMG Compatibility Matrix. The latest compatibility with optical modules and DACs can be found at <https://tmgmatrix.cisco.com/>
- For list of supported optics and cables for VIC 1455, VIC 1457, VIC 1495 and VIC 1497 refer to VIC 1400 series data sheet at the following links:
 - <https://www.cisco.com/c/en/us/products/collateral/interfaces-modules/unified-computing-system-adapters/datasheet-c78-741130.html>
 - <https://www.cisco.com/c/en/us/products/collateral/interfaces-modules/unified-computing-system-adapters/datasheet-c78-734727.html>

Refer to the these links for additional Connectivity Options.

Intel:	Marvell/Qlogic:	Mellanox:
Product Guide	41000 series Interoperability Matrix	Firmware Release Notes
Speed White Paper	45000 series Interoperability Matrix	

STEP 9 ORDER M.2 SATA SSD (OPTIONAL)

Order one or two matching M.2 SATA SSDs (see [Table 10](#)) along with a mini storage carrier or a boot-optimized RAID controller (see [Table 11](#)).



NOTE: It is recommended that M.2 SATA SSDs be used as boot-only devices.

Each mini storage carrier or boot-optimized RAID controller can accommodate up to two SATA M.2 SSDs shown in [Table 10](#).

Table 10 M.2 SATA SSDs

Product ID (PID)	PID Description
UCS-M2-240G	240GB SATA M.2
UCS-M2-480G	480GB M.2 SATA SSD
UCS-M2-960G	960GB SATA M.2

Table 11 Mini Storage Carrier/Boot-Optimized RAID Controller

Product ID (PID)	PID Description
UCS-MSTOR-M2	Mini Storage Carrier for M.2 SATA (holds up to 2 M.2 SATA SSDs)
UCS-M2-HWRAID	Cisco Boot optimized M.2 RAID controller (holds up to 2 M.2 SATA SSDs)

Caveats

- You cannot mix M.2 SATA SSDs with SD cards.
- Order either one or two identical M.2 SATA SSDs for the mini-storage carrier or boot-optimized RAID controller. You cannot mix M.2 SATA SSD capacities.

STEP 10 ORDER SD CARD MODULE (OPTIONAL)

Order SD cards. There are two locations, SD1 and SD2.

Table 12 128 GB Secure Digital (SD) Card

Product ID (PID)	PID Description
UCS-SD-128G	128 GB SD Card for UCS Servers
UCS-SD-64G-S	64 GB SD Card for UCS Servers
UCS-SD-32G-S	32 GB SD Card for UCS Servers

Caveats

- Install either one or two SD cards
- Do not mix SD card sizes
- You cannot mix SD cards with an internal M.2 SATA SSDs (see [ORDER OPTIONAL PCIe OPTION CARD ACCESSORIES](#)).

STEP 11 ORDER MICRO-SD CARD MODULE (OPTIONAL)

Order one or two matching capacity M.2 SATA SSDs as desired.

Table 13 32 GB Secure Digital (SD) Card

Product ID (PID)	PID Description
UCS-MSD-32G	32GB Micro-SD Card for UCS servers

Caveats

- Install either one or two M.2 SATA SSDs.
- You cannot mix M.2 SATA SSDs with SD (see [ORDER SD CARD MODULE \(OPTIONAL\)](#)).

STEP 12 ORDER OPTIONAL USB 3.0 DRIVE

You can order one optional USB 3.0 drive.

The USB drive ordering information is listed in [Table 14](#)

Table 14 USB 3.0 Drive

Product ID (PID)	PID Description
UCS-USBFLSHB-16GB=	UCS Servers 16 GB Flash USB Drive

See [Figure 6 on page 42](#) for the location of the USB connector

STEP 13 ORDER SECURITY DEVICES (OPTIONAL)

A Trusted Platform Module (TPM) is a computer chip (microcontroller) that can securely store artifacts used to authenticate the platform (server). These artifacts can include passwords, certificates, or encryption keys. A TPM can also be used to store platform measurements that help ensure that the platform remains trustworthy. Authentication (ensuring that the platform can prove that it is what it claims to be) and attestation (a process helping to prove that a platform is trustworthy and has not been breached) are necessary steps to ensure safer computing in all environments.

A chassis intrusion switch gives a notification of any unauthorized mechanical access into the server. The security device ordering information is listed in [Table 16](#).

Choose an optional Trusted Platform Module (TPM) from [Table 15](#).

Table 15 TPM

Product ID (PID)	PID Description
UCSX-TPM2-002-C	Trusted Platform Module 2.0 for UCS servers
UCSX-TPM2-002B-C	Trusted Platform Module2.0 UCS servers (FIPS 140-2 Compliant)



NOTE:

- The TPM module used in this system conforms to TPM 2.0, as defined by the Trusted Computing Group (TCG). It is also SPI-based.
- TPM installation is supported after-factory. However, a TPM installs with a one-way screw and cannot be replaced, upgraded, or moved to another server. If a server with a TPM is returned, the replacement server must be ordered with a new TPM.

STEP 14 SELECT LOCKING SECURITY BEZEL (OPTIONAL)

An optional locking bezel can be mounted to the front of the chassis to prevent unauthorized access to the drives.

Select the locking bezel [Table 16](#)

Table 16 C4200 Locking Security Bezel

Product ID (PID)	PID Description
UCSC-BZL-C240M5	Locking Security Bezel for 2U C-series rack servers

STEP 15 SELECT POWER SUPPLY

The Cisco UCS C4200 accommodates two power supplies. Two power supplies are mandatory. Use [Table 17](#) to order the power supplies.



WARNING: Starting 1st 2024, only Titanium rated PSUs are allowed to be shipped to EU, UK and other countries that adopted Lot 9 Regulation.

Table 17 Power Supply

Product ID (PID)	PID Description
UCSC-PSU3-2400W	UCS 2400W AC Power Supply (Not EU/UK Lot 9 Compliant)



NOTE: DC PSUs are not impacted by Lot 9 Regulation and are EU/UK Lot 9 compliant

STEP 16 SELECT POWER CORD(s)

Each power supply in the server has a power cord. Standard power cords or jumper power cords are available for connection to the server. The shorter jumper power cords, for use in racks, are available as an optional alternative to the standard power cords.

Using [Table 18](#), select the appropriate AC power cords. You can select a minimum of no power cords and a maximum of two. If you select the option R2XX-DMYPWRCORD, no power cord is shipped with the server.

Table 18 Available Power Cords

Product ID (PID)	PID Description	Images
R2XX-DMYPWRCORD	No power cord (dummy PID to allow for a no power cord option)	Not applicable
CAB-AC-2500W-EU	Power Cord, 250Vac 16A, Europe	Images not available
CAB-AC-2500W-INT	Power Cord, 250Vac 16A, INTL	Images not available
CAB-C19-CBN	Cabinet Jumper Power Cord, 250 VAC 16A, C20-C19 Connectors	Images not available
CAB-AC-C6K-TWLK	Power Cord, 250Vac 16A, twist lock NEMA L6-20 plug, US	Images not available
CAB-AC-2500W-US1	Power Cord, 250Vac 16A, straight blade NEMA 6-20 plug, US	Images not available
CAB-AC-16A-AUS	Power Cord, 250VAC, 16A, Australia C19	Images not available
CAB-AC16A-CH	16A AC Power Cord For China	Images not available
CAB-AC-2500W-ISRL	Power Cord,250VAC,16A,Israel	Images not available
CAB-S132-C19-ISRL	S132 to IEC-C19 14ft Israeli	Images not available
CAB-ACS-16	AC Power Cord (Swiss) 16A	Images not available
CAB-IR2073-C19-AR	IRSM 2073 to IEC-C19 14ft Argen	Images not available
CAB-BS1363-C19-UK	BS-1363 to IEC-C19 14ft UK	Images not available
CAB-SABS-C19-IND	SABS 164-1 to IEC-C19 India	Images not available
CAB-C2316-C19-IT	CEI 23-16 to IEC-C19 14ft Italy	Images not available
CAB-9K16A-BRZ	Power Cord 250VAC 16A, Brazil, Src Plug EL224-C19	Images not available
CAB-C19-C20-3M-JP	Power Cord C19-C20, 3M/10ft Japan PSE mark	Images not available
CAB-L520P-C19-US	NEMA L5-20 to IEC-C19 6ft US	Images not available
CAB-US620P-C19-US	NEMA 6-20 to IEC-C19 13ft US	Images not available
CAB-9K16A-KOR	Power Cord 250VAC 16A, Korea, Src Plug	Images not available

STEP 17 SELECT TOOL-LESS RAIL KIT AND OPTIONAL REVERSIBLE CABLE MANAGEMENT ARM

The reversible cable management arm mounts on either the right or left slide rails at the rear of the server and is used for cable management. Use [Table 20](#) to order a cable management arm.

Select a Tool-less Rail Kit

Select a tool-less rail kit from [Table 19](#).

Table 19 Tool-less Rail Kit Options

Product ID (PID)	PID Description
UCSC-RAILF-M4	Friction Rail Kit for C220 M4 and C220 M5 Servers
UCSC-RAILB-M4	Ball Bearing Rail Kit for C220 and C240 M4/M5 Rack Servers

Table 20 Cable Management Arm

Product ID (PID)	PID Description
UCSC-CMAF-C4200	Reversible CMA for C4200 ball bearing rail kit

STEP 18 SELECT A KVM CABLE (OPTIONAL)

The KVM cable provides a connection into the server, providing a DB9 serial connector, a VGA connector for a monitor, and dual USB 2.0 ports for a keyboard and mouse. With this cable, you can create a direct connection to the operating system and the BIOS running on the server.

The KVM cable ordering information is listed in [Table 21](#).

Table 21 KVM Cable

Product ID (PID)	PID Description
N20-BKVM=	KVM cable for server console port

Figure 5 KVM Cable

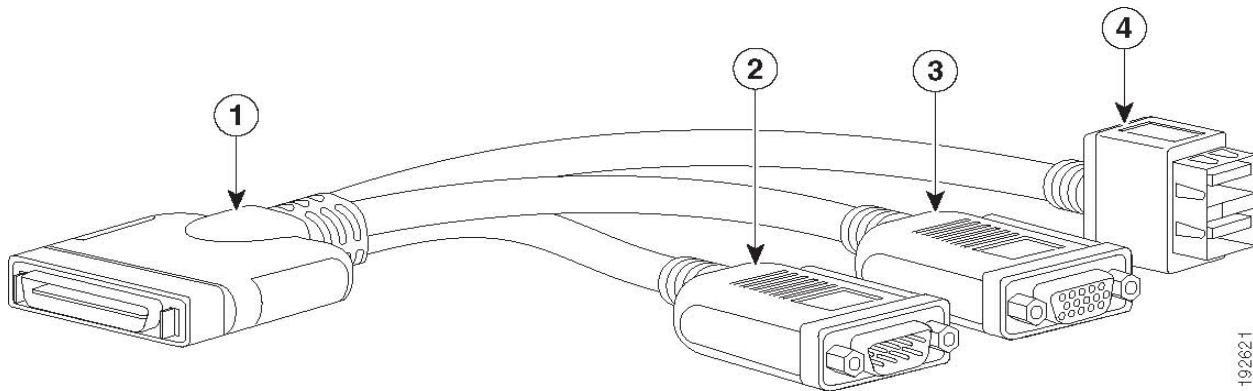

1	Connector (to server front panel)	3	VGA connector (for a monitor)
2	DB-9 serial connector	4	Two-port USB 2.0 connector (for a mouse and keyboard)

STEP 19 SELECT OPERATING SYSTEM AND VALUE-ADDED SOFTWARE

Several operating systems and value-added software programs are available. Select as desired from [Table 22](#).



NOTE: VMware is on Compliance Hold. Contact the Compute-Vmware-Hold@cisco.com mailer to see if you are allowed to receive VMware Licenses

Table 22 Operating System

Product ID (PID)	PID Description
Microsoft Windows Server	
MSWS-19-DC16C	Windows Server 2019 Data Center (16 Cores/Unlimited VMs)
MSWS-19-DC16C-NS	Windows Server 2019 DC (16 Cores/Unlim VMs) - No Cisco SVC
MSWS-19-ST16C	Windows Server 2019 Standard (16 Cores/2 VMs)
MSWS-19-ST16C-NS	Windows Server 2019 Standard (16 Cores/2 VMs) - No Cisco SVC
MSWS-22-ST16C	Windows Server 2022 Standard (16 Cores/2 VMs)
MSWS-22-ST16C-NS	Windows Server 2022 Standard (16 Cores/2 VMs) - No Cisco SVC
MSWS-22-DC16C	Windows Server 2022 Data Center (16 Cores/Unlimited VMs)
MSWS-22-DC16C-NS	Windows Server 2022 DC (16 Cores/Unlim VMs) - No Cisco SVC
Red Hat	
RHEL-2S2V-1A	Red Hat Enterprise Linux (1-2 CPU,1-2 VN); 1-Yr Support Req
RHEL-2S2V-3A	Red Hat Enterprise Linux (1-2 CPU,1-2 VN); 3-Yr Support Req
RHEL-2S2V-5A	Red Hat Enterprise Linux (1-2 CPU,1-2 VN); 5-Yr Support Req
RHEL-VDC-2SUV-1A	RHEL for Virt Datacenters (1-2 CPU, Unlim VN) 1 Yr Supp Req
RHEL-VDC-2SUV-3A	RHEL for Virt Datacenters (1-2 CPU, Unlim VN) 3 Yr Supp Req
RHEL-VDC-2SUV-5A	RHEL for Virt Datacenters (1-2 CPU, Unlim VN) 5 Yr Supp Req
Red Hat Ent Linux/ High Avail/ Res Strg/ Scal	
RHEL-2S2V-1S	Red Hat Enterprise Linux (1-2 CPU,1-2 VN); Prem 1-Yr SnS
RHEL-2S2V-3S	Red Hat Enterprise Linux (1-2 CPU,1-2 VN); Prem 3-Yr SnS
RHEL-2S-HA-1S	RHEL High Availability (1-2 CPU); Premium 1-yr SnS
RHEL-2S-HA-3S	RHEL High Availability (1-2 CPU); Premium 3-yr SnS
RHEL-2S-RS-1S	RHEL Resilent Storage (1-2 CPU); Premium 1-yr SnS

Table 22 (continued) Operating System

Product ID (PID)	PID Description
RHEL-2S-RS-3S	RHEL Resilent Storage (1-2 CPU); Premium 3-yr SnS
RHEL-2S-SFS-1S	RHEL Scalable File System (1-2 CPU); Premium 1-yr SnS
RHEL-2S-SFS-3S	RHEL Scalable File System (1-2 CPU); Premium 3-yr SnS
RHEL-VDC-2SUV-1S	RHEL for Virt Datacenters (1-2 CPU, Unlim VN) 1 Yr SnS Reqd
RHEL-VDC-2SUV-3S	RHEL for Virt Datacenters (1-2 CPU, Unlim VN) 3 Yr SnS Reqd
VMware	
VMW-VSP-STD-1A	VMware vSphere 6 Standard (1 CPU), 1-yr, Support Required
VMW-VSP-STD-3A	VMware vSphere 6 Standard (1 CPU), 3-yr, Support Required
VMW-VSP-STD-5A	VMware vSphere 6 Standard (1 CPU), 5-yr, Support Required
VMW-VSP-EPL-3A	VMware vSphere 6 Ent Plus (1 CPU), 3-yr, Support Required
VMW-VSP-EPL-1A	VMware vSphere 6 Ent Plus (1 CPU), 1-yr, Support Required
VMW-VSP-EPL-5A	VMware vSphere 6 Ent Plus (1 CPU), 5-yr, Support Required
SUSE	
SLES-2S2V-1A	SUSE Linux Enterprise Svr (1-2 CPU,1-2 VM); 1-Yr Support Req
SLES-2S2V-3A	SUSE Linux Enterprise Svr (1-2 CPU,1-2 VM); 3-Yr Support Req
SLES-2S2V-5A	SUSE Linux Enterprise Svr (1-2 CPU,1-2 VM); 5-Yr Support Req4.0(4b)4.0(4b)
SLES-2S2V-1S	SUSE Linux Enterprise Svr (1-2 CPU,1-2 VM); Prio 1-Yr SnS
SLES-2SUV-3S	SUSE Linux Enterprise Svr (1-2 CPU,Unl VM); Prio 3-Yr SnS
SLES-2SUV-5S	SUSE Linux Enterprise Svr (1-2 CPU,Unl VM); Prio 5-Yr SnS
SLES-2S-HA-1S	SUSE Linux High Availability Ext (1-2 CPU); 1yr SnS
SLES-2S-HA-3S	SUSE Linux High Availability Ext (1-2 CPU); 3yr SnS
SLES-2S-HA-5S	SUSE Linux High Availability Ext (1-2 CPU); 5yr SnS
SLES-2S-GC-1S	SUSE Linux GEO Clustering for HA (1-2 CPU); 1yr Sns
SLES-2S-GC-3S	SUSE Linux GEO Clustering for HA (1-2 CPU); 3yr SnS
SLES-2S-GC-5S	SUSE Linux GEO Clustering for HA (1-2 CPU); 5yr SnS
SLES-2S-LP-1S	SUSE Linux Live Patching Add-on (1-2 CPU); 1yr SnS Required
SLES-2S-LP-3S	SUSE Linux Live Patching Add-on (1-2 CPU); 3yr SnS Required
SLES-2S-LP-1A	SUSE Linux Live Patching Add-on (1-2 CPU); 1yr Support Req
SLES-2S-LP-3A	SUSE Linux Live Patching Add-on (1-2 CPU); 3yr Support Req

STEP 20 SELECT OPERATING SYSTEM MEDIA KIT

Select the optional operating system media listed in [Table 23](#).

Table 23 OS Media

Product ID (PID)	PID Description
MSWS-19-ST16C-RM	Windows Server 2019 Stan (16 Cores/2 VMs) Rec Media DVD Only
MSWS-19-DC16C-RM	Windows Server 2019 DC (16Cores/Unlim VM) Rec Media DVD Only

STEP 21 SELECT SERVICE and SUPPORT LEVEL

A variety of service options are available, as described in this section.

Unified Computing Warranty, No Contract

If you have noncritical implementations and choose to have no service contract, the following coverage is supplied:

- Three-year parts coverage.
- Next business day (NBD) onsite parts replacement eight hours a day, five days a week.
- 90-day software warranty on media.
- Ongoing downloads of BIOS, drivers, and firmware updates.
- UCSM updates for systems with Unified Computing System Manager. These updates include minor enhancements and bug fixes that are designed to maintain the compliance of UCSM with published specifications, release notes, and industry standards.

Smart Net Total Care (SNTC) for UCS

For support of the entire Unified Computing System, Cisco offers the Cisco Smart Net Total Care for UCS Service. This service provides expert software and hardware support to help sustain performance and high availability of the unified computing environment. Access to Cisco Technical Assistance Center (TAC) is provided around the clock, from anywhere in the world

For systems that include Unified Computing System Manager, the support service includes downloads of UCSM upgrades. The Cisco Smart Net Total Care for UCS Service includes flexible hardware replacement options, including replacement in as little as two hours. There is also access to Cisco's extensive online technical resources to help maintain optimal efficiency and uptime of the unified computing environment. For more information please refer to the following url: <http://www.cisco.com/c/en/us/services/technical/smart-net-total-care.html?stickynav=1>

You can choose a desired service listed in [Table 24](#).

Table 24 Cisco SNTC for UCS Service (PID UCSC-C4200-SFF)

Service SKU	Service Level GSP	On Site?	Description
CON-PREM-C4200SFF	C2P	Yes	SNTC 24X7X20S
CON-UCSD8-C4200SFF	UCSD8	Yes	UC SUPP DR 24X7X20S*
CON-OSP-C4200SFF	C4P	Yes	SNTC 24X7X40S
CON-UCSD7-C4200SFF	UCSD7	Yes	UCS DR 24X7X40S*
CON-C4PL-C4200SFF	C4PL	Yes	LL 24X7X40S**
CON-USD7L-C4200SFF	USD7L	Yes	LLUCS HW DR 24X7X40S***
CON-OSE-C4200SFF	C4S	Yes	SNTC 8X5X40S
CON-UCSD6-C4200SFF	UCSD6	Yes	UC SUPP DR 8X5X40S*
CON-SNCO-C4200SFF	SNCO	Yes	SNTC 8x7xNCDOS****

Table 24 Cisco SNTC for UCS Service (PID UCSC-C4200-SFF)

Service SKU	Service Level GSP	On Site?	Description
CON-OS-C4200SFF	CS	Yes	SNTC 8X5XNBDOS
CON-UCSD5-C4200SFF	UCSD5	Yes	UCS DR 8X5XNBDOS*
CON-S2P-C4200SFF	S2P	No	SNTC 24X7X2
CON-SNTP-C4200SFF	SNTP	No	SNTC 24X7X4
CON-SNTPL-C4200SFF	SNTPL	No	LL 24X7X4**
CON-SNTE-C4200SFF	SNTE	No	SNTC 8X5X4
CON-SNC-C4200SFF	SNC	No	SNTC 8x7xNCD****
CON-SNT-C4200SFF	SNT	No	SNTC 8X5XNBD
CON-SW-C4200SFF	SW	No	SNTC NO RMA

*Includes Drive Retention (see below for full description)

**Includes Local Language Support (see below for full description) - Only available in China and Japan

***Includes Local Language Support and Drive Retention - Only available in China and Japan

****Available in China Only

Smart Net Total Care for Cisco UCS Onsite Troubleshooting Service

An enhanced offer over traditional Smart Net Total Care which provides onsite-troubleshooting expertise to aid in the diagnostics and isolation of hardware issue within our customers' Cisco Unified Computing System (UCS) environment. It is delivered by a Cisco Certified field engineer (FE) in collaboration with remote TAC engineer and Virtual Internet working Support Engineer (VISE). You can choose a desired service listed in [Table 25](#)

Table 25 SNTC for Cisco UCS Onsite Troubleshooting Service (PID UCSC-C4200-SFF)

Service SKU	Service Level GSP	On Site?	Description
CON-OSPT-C4200SFF	OSPT	Yes	24X7X4OS Trblshtg
CON-OSPTD-C4200SFF	OSPTD	Yes	24X7X4OS TrblshtgDR*

*Includes Drive Retention (see below for full description)

Solution Support for UCS

Solution Support includes both Cisco product support and solution-level support, resolving complex issues in multivendor environments, on average, 43% more quickly than product support alone. Solution Support is a critical element in data center administration, to help rapidly resolve any issue encountered, while maintaining performance, reliability, and return on investment.

This service centralizes support across your multivendor Cisco environment for both our products and solution partner products you’ve deployed in your ecosystem. Whether there is an issue with a Cisco or solution partner product, just call us. Our experts are the primary point of contact and own the case from first call to resolution. For more information please refer to the following url:

<http://www.cisco.com/c/en/us/services/technical/solution-support.html?stickynav=1>

You can choose a desired service listed in **Table 26**

Table 26 Solution Support for UCS Service (PID UCSC-C4200-SFF)

Service SKU	Service Level GSP	On Site?	Description
CON-SSC2P-C4200SFF	SSC2P	Yes	SOLN SUPP 24X7X2OS
CON-SSC4P-C4200SFF	SSC4P	Yes	SOLN SUPP 24X7X4OS
CON-SSC4S-C4200SFF	SSC4S	Yes	SOLN SUPP 8X5X4OS
CON-SSCS-C4200SFF	SSCS	Yes	SOLN SUPP 8X5XNBDOS
CON-SSDR7-C4200SFF	SSDR7	Yes	SSPT DR 24X7X4OS*
CON-SSDR5-C4200SFF	SSDR5	Yes	SSPT DR 8X5XNBDOS*
CON-SSS2P-C4200SFF	SSS2P	No	SOLN SUPP 24X7X2
CON-SSSNP-C4200SFF	SSSNP	No	SOLN SUPP 24X7X4
CON-SSSNE-C4200SFF	SSSNE	No	SOLN SUPP 8X5X4
CON-SSSNC-C4200SFF	SSSNC	No	SOLN SUPP NCD**
CON-SSSNT-C4200SFF	SSSNT	No	SOLN SUPP 8X5XNBD
Includes Drive Retention (see below for description)			
**Available in China only			

Smart Net Total Care for UCS Hardware Only Service

For faster parts replacement than is provided with the standard Cisco Unified Computing System warranty, Cisco offers the Cisco Smart Net Total Care for UCS Hardware Only Service. You can choose from two levels of advanced onsite parts replacement coverage in as little as four hours. Smart Net Total Care for UCS Hardware Only Service provides remote access any time to Cisco

support professionals who can determine if a return materials authorization (RMA) is required. You can choose a desired service listed in [Table 27](#)

Table 27 SNTC for UCS Hardware Only Service (PID UCSC-C4200-SFF)

Service SKU	Service Level GSP	On Site?	Description
CON-UCW7-C4200SFF	UCW7	Yes	UCS HW 24X7X4OS
CON-UCWD7-C4200SFF	UCWD7	Yes	UCS HW+DR 24X7X4OS*
CON-UCW5-C4200SFF	UCW5	Yes	UCS HW 8X5XNBDOS
CON-UCWD5-C4200SFF	UCWD5	Yes	UCS HW+DR 8X5XNBDOS*
*Includes Drive Retention (see below for description)			

Partner Support Service for UCS

Cisco Partner Support Service (PSS) is a Cisco Collaborative Services service offering that is designed for partners to deliver their own branded support and managed services to enterprise customers. Cisco PSS provides partners with access to Cisco's support infrastructure and assets to help them:

- Expand their service portfolios to support the most complex network environments
- Lower delivery costs
- Deliver services that increase customer loyalty

PSS options enable eligible Cisco partners to develop and consistently deliver high-value technical support that capitalizes on Cisco intellectual assets. This helps partners to realize higher margins and expand their practice.

PSS is available to all Cisco PSS partners.

The two Partner Unified Computing Support Options include:

- Partner Support Service for UCS
- Partner Support Service for UCS Hardware Only

PSS for UCS provides hardware and software support, including triage support for third party software, backed by Cisco technical resources and level three support. You can choose a desired service listed in [Table 28](#).

Table 28 PSS for UCS (PID UCSC-C4200-SFF)

Service SKU	Service Level GSP	On Site?	Description
CON-PSJ8-C4200SFF	PSJ8	Yes	UCS PSS 24X7X2 OS
CON-PSJ7-C4200SFF	PSJ7	Yes	UCS PSS 24X7X4 OS
CON-PSJD7-C4200SFF	PSJD7	Yes	UCS PSS 24X7X4 DR*

Table 28 PSS for UCS (PID UCSC-C4200-SFF)

CON-PSJ6-C4200SFF	PSJ6	Yes	UCS PSS 8X5X4 OS
CON-PSJD6-C4200SFF	PSJD6	Yes	UCS PSS 8X5X4 DR*
CON-PSJ4-C4200SFF	PSJ4	No	UCS SUPP PSS 24X7X2
CON-PSJ3-C4200SFF	PSJ3	No	UCS SUPP PSS 24X7X4
CON-PSJ2-C4200SFF	PSJ2	No	UCS SUPP PSS 8X5X4
CON-PSJ1-C4200SFF	PSJ1	No	UCS SUPP PSS 8X5XNBD

*Includes Drive Retention (see below for description)

PSS for UCS Hardware Only

PSS for UCS Hardware Only provides customers with replacement parts in as little as two hours and provides remote access any time to Partner Support professionals who can determine if a return materials authorization (RMA) is required. You can choose a desired service listed in [Table 29](#)

Table 29 PSS for UCS Hardware Only (PID UCSC-C4200-SFF)

Service SKU	Service Level GSP	On Site?	Description
CON-PSW7-C4200SFF	PSW7	Yes	UCS W PSS 24X7X4 OS
CON-PSWD7-C4200SFF	PSWD7	Yes	UCS W PSS 24X7X4 DR*
CON-PSW6-C4200SFF	PSW6	Yes	UCS W PSS 8X5X4 OS
CON-PSWD6-C4200SFF	PSWD6	Yes	UCS W PSS 8X5X4 DR*
CON-PSW4-C4200SFF	PSW4	No	UCS W PL PSS 24X7X2
CON-PSW3-C4200SFF	PSW3	No	UCS W PL PSS 24X7X4
CON-PSW2-C4200SFF	PSW2	No	UCS W PL PSS 8X5X4

*Includes Drive Retention (see below for description)

Unified Computing Combined Support Service

Combined Services makes it easier to purchase and manage required services under one contract. SNTC services for UCS help increase the availability of your vital data center infrastructure and realize the most value from your unified computing investment. The more benefits you realize from the Cisco Unified Computing System (Cisco UCS), the more important the technology becomes to your business. These services allow you to:

- Optimize the uptime, performance, and efficiency of your UCS
- Protect your vital business applications by rapidly identifying and addressing issues
- Strengthen in-house expertise through knowledge transfer and mentoring

- Improve operational efficiency by allowing UCS experts to augment your internal staff resources
- Enhance business agility by diagnosing potential issues before they affect your operations,

You can choose a desired service listed in [Table 30](#).

Table 30 Combined Support Service for UCS (PID UCSC-C4200-SFF)

Service SKU	Service Level GSP	On Site?	Description
CON-NCF2P-C4200SFF	NCF2P	Yes	CMB SVC 24X7X2O5
CON-NCF4P-C4200SFF	NCF4P	Yes	CMB SVC 24X7X4O5
CON-NCF4S-C4200SFF	NCF4S	Yes	CMB SVC 8X5X4O5
CON-NCFCS-C4200SFF	NCFCS	Yes	CMB SVC 8X5XNBDOS
CON-NCF2-C4200SFF	NCF2	No	CMB SVC 24X7X2
CON-NCFP-C4200SFF	NCFP	No	CMB SVC 24X7X4
CON-NCFE-C4200SFF	NCFE	No	CMB SVC 8X5X4
CON-NCFT-C4200SFF	NCFT	No	CMB SVC 8X5XNBD
CON-NCFW-C4200SFF	NCFW	No	CMB SVC SW

UCS Drive Retention Service

With the Cisco Unified Computing Drive Retention Service, you can obtain a new disk drive in exchange for a faulty drive without returning the faulty drive.

Sophisticated data recovery techniques have made classified, proprietary, and confidential information vulnerable, even on malfunctioning disk drives. The Drive Retention service enables you to retain your drives and ensures that the sensitive data on those drives is not compromised, which reduces the risk of any potential liabilities. This service also enables you to comply with regulatory, local, and federal requirements.

If your company has a need to control confidential, classified, sensitive, or proprietary data, you might want to consider one of the Drive Retention Services listed in the above tables (where available)



NOTE: Cisco does not offer a certified drive destruction service as part of this service.

Local Language Technical Support for UCS

Where available, and subject to an additional fee, local language support for calls on all assigned severity levels may be available for specific product(s) - see tables above.

For a complete listing of available services for Cisco Unified Computing System, see this URL: http://www.cisco.com/en/US/products/ps10312/serv_group_home.html

SUPPLEMENTAL MATERIAL

CHASSIS

An internal view of the Cisco UCS C4200 rack server chassis with the top cover removed is shown in [Figure 6](#).

Figure 6 Cisco UCS C4200 With Top Cover Off

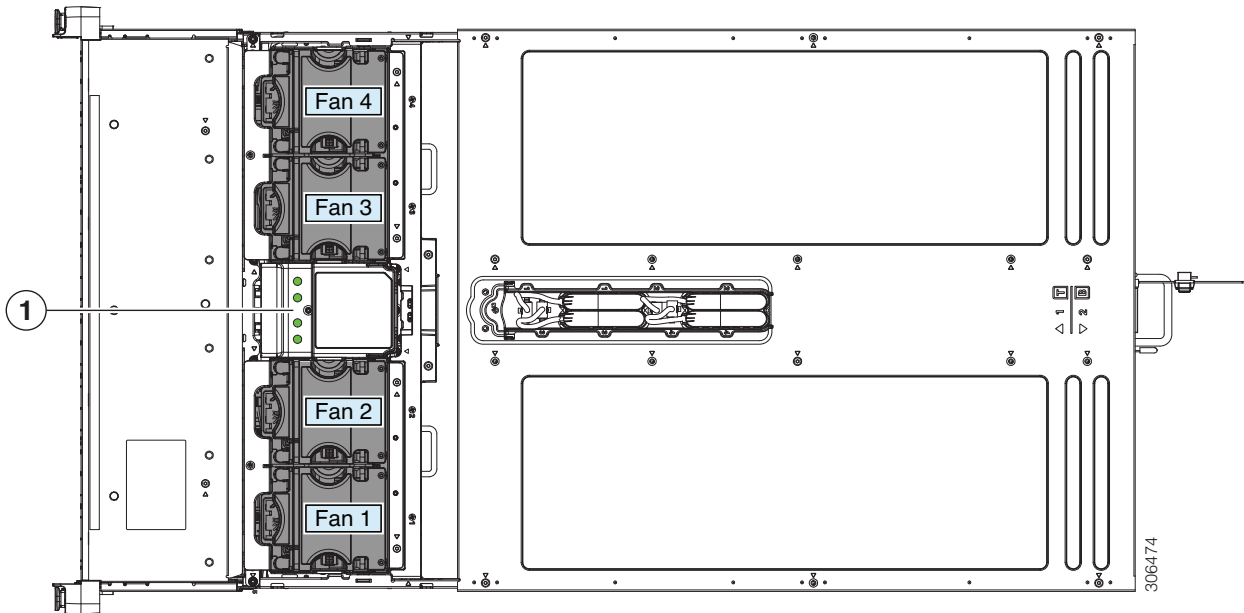

1	<p>Fan module fault LEDs on fan tray (one LED for each fan module)</p> <ul style="list-style-type: none"> ■ Green-Fan is OK. ■ Amber-Fan has a fault or is not fully seated
---	---

BLOCK DIAGRAM

Figure 7 UCS C125 M5 Block Diagram

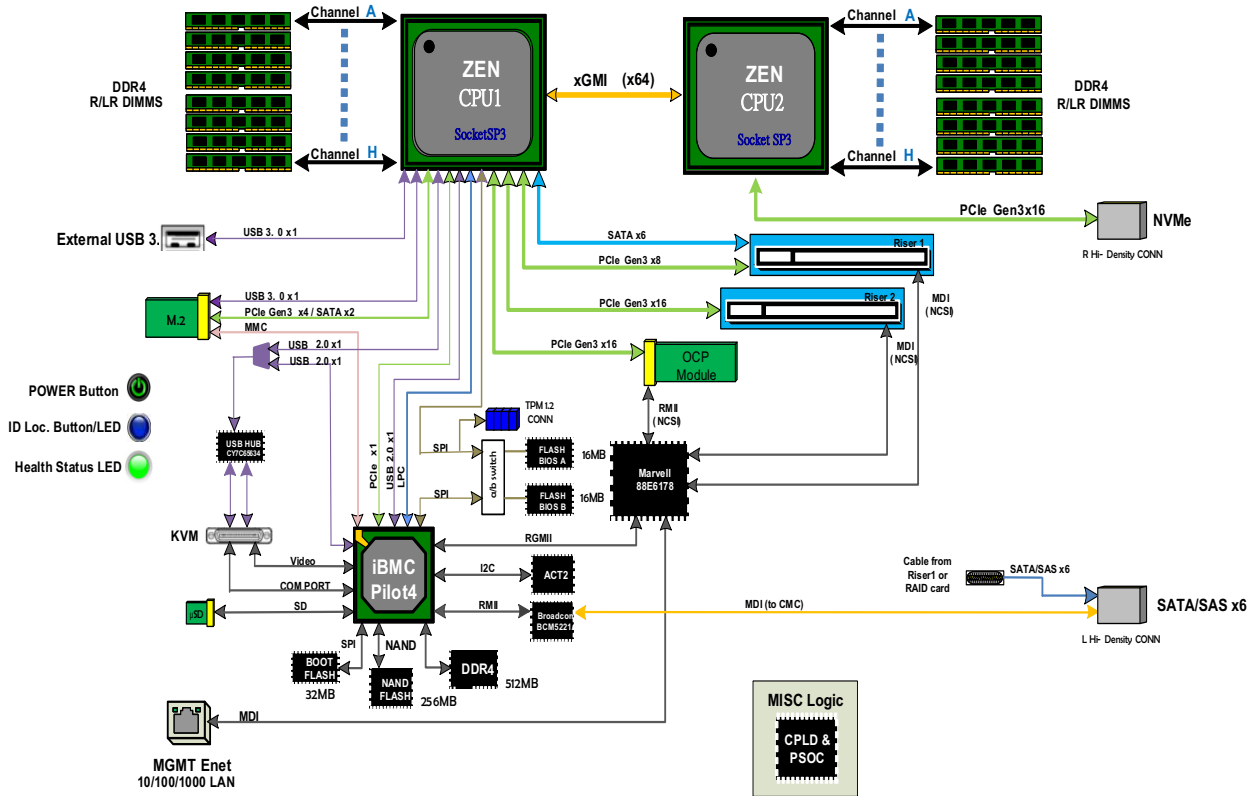

CPU and DIMMs

The following figure shows the CPU and DIMM socket placement on the C125 M5 motherboard.

- Each server node has 16 DIMM sockets total (8 for each CPU).
- DIMM sockets are organized as one DIMM per channel.

Figure 8 C125 M5 Compute Node Internal Component Locations

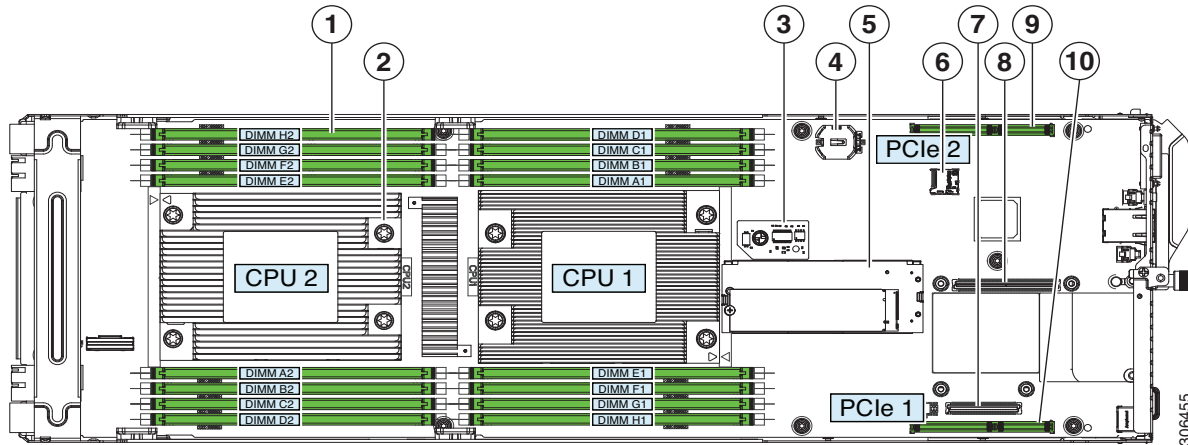

1	DIMM sockets (each CPU supports 8 sockets, 16 total)	6	Micro-SD card socket on server board
2	AMD EPYC™ 7000 series CPUs and heatsinks (one or two) The front and rear CPUs use different heatsinks	7	OCP adapter card socket A OCP adapter cards that require a x8 lane plug into only socket B. OCP cards that require a x16 lane plug in to both sockets A and B
3	Trusted platforms module (TPM) location on server board	8	OCP adapter card socket B OCP adapter cards that require a x8 lane plug into only socket B. OCP cards that require a x16 lane plug in to both sockets A and B
4	Real-time clock (RTC) battery CR2032 horizontal socket location on server board	9	Socket for PCIe riser 2/PCIe slot 2 (riser not shown in this view) Riser 2 plugs into a board socket to provide one horizontal PCIe slot (half-height half length, x16 slot)
5	Mini-storage module socket on server board supports either an SD card carrier with two slots for SD cards, or an M.2 SSD carrier with two slots for M.2 SATA SSDs	10	Socket for PCIe riser 1/PCIe slot 1 (riser not shown in this view) Riser 1 plugs into this socket to provide one horizontal PCIe slot (half-height half length, x8 slot) This is the required slot for a SAS RAID controller. The controller supports the six front-loading drives in the chassis that correspond to the node's position (group 1, 2, 3, or 4) Riser 1 also includes one x8 slimline connector for pass-through (JBOD) SATA drive control

DIMM Sockets

The following figure shows the position of the DIMM sockets and how they are labeled on a C125 M5 motherboard. Each DIMM channel consist of one lettered slot (for example, CPU1 A1, B1, C1, or CPU2 A2, B2, C2, etc) for each CPU.

Figure 9 shows the memory slot physically placement.

Figure 9 DIMM and CPU Numbering

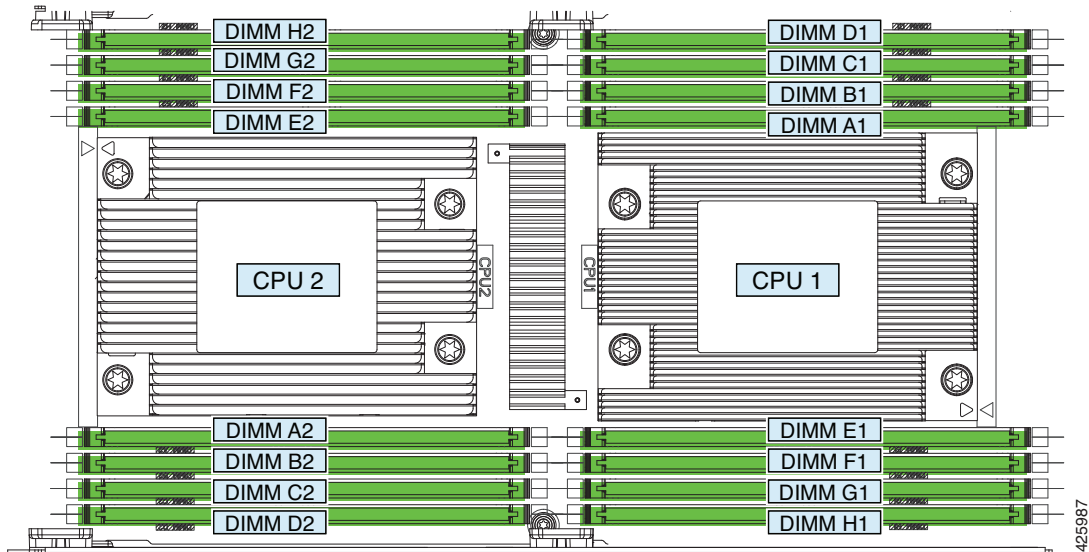

Memory Population Rules

- For optimal performance, spread DIMMs evenly across both CPUs and all channels. Populate the DIMM slots of each CPU identically.
- For optimal performance, populate DIMMs in the order shown in the following table, depending on the number of DIMMs per CPU.



NOTE: The table below lists recommended configurations.

DIMM Population Rules

AMD EPYC™ processors are designed with an industry leading eight channels of DDR4 memory per processor. With more memory channels, applications will have fewer memory bottlenecks, and better performance for memory bound workloads. Though EPYC™ CPUs do not require a specific loading order for memory DIMMs, its advised to observe the following recommended population guidelines to obtain best performance:

- Any unused DIMM socket must have a DIMM blanking panel installed to ensure adequate airflow and cooling.
- Though a CPU can be populated with a single DIMM as a minimum configuration
 - Full memory bandwidth requires one DIMM per channel (A-H) be populated to obtain best performance with bandwidth sensitive workloads
 - At least one DIMM populated for each channel pair in the system (A,C,E,G) is minimally recommended
- Always balance the memory capacity per channel pair on a given CPU
- In a dual CPU configuration, always balance memory capacity between them as described in [Table 31](#)

Figure 10 Memory Organization

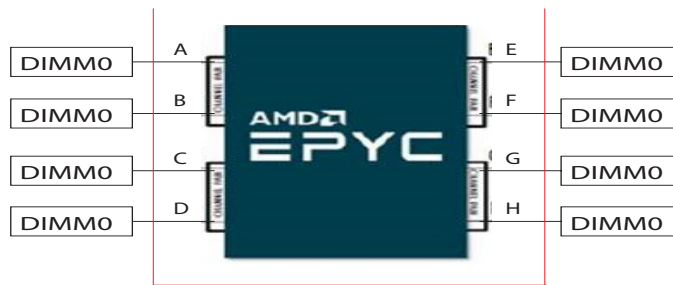

DDR4 Speeds with 1 DIMM Per channel Populated
 SR/DR RDIMM and RDIMM: 2666 MHz

Table 31 DIMM Population Order

Number of DIMMs Per CPU	CPU 1 Slots (In a single-CPU node, populate only these slots)	CPU 2 Slots
1	A1	A2
2	A1, E1	A2, E2
3	A1, E1, C1	A2, E2, C2
4	A1, E1, C1, G1	A2, E2, C2, G2
5	A1, E1, C1, G1, B1	A2, E2, C2, G2, B2
6	A1, E1, C1, G1, B1, F1	A2, E2, C2, G2, B2, F2
7	A1, E1, C1, G1, B1, F1, D1	A2, E2, C2, G2, B2, F2, D2
8	A1, E1, C1, G1, B1, F1, D1, H1	A2, E2, C2, G2, B2, F2, D2, H2

Upgrade and Servicing-Related Parts

This section lists the upgrade and servicing-related parts you may need during the life of your server. Some of these parts are configured with every server, and some may be ordered when needed or may be ordered and kept on hand as spares for future use. See [Table 32](#)

Table 32 Upgrade and Servicing-related Parts for Cisco UCS C4200 Server

Spare Product ID (PID)	Descriptions
Base Chassis	
UCSC-C4200-SFF=	Cisco UCS C4200 Base Chassis FRU Spare
UCSC-BBLKD-S2=	Cisco UCS C4200 C-Series M5 SFF drive blanking panel spare
UCSC-NBLKD-C4200=	Cisco UCS C4200 Node Blank spare
UCSC-BZL-C240M5=	Cisco UCS C4200 Security Bezel for 2U M5 servers spare
UCSC-FAN-C4200=	Cisco UCS C4200 Fan Module (one) spare
UCSC-PSU3-2400W=	Cisco UCS C4200 2400W AC power supply spare
UCSC-HS-C125=	Cisco UCS C125 M5 Heat sink for UCS C125 Front CPU spare
UCSC-HS2-C125=	Cisco UCS C125 M5 Heat sink for UCS C125 Rear CPU
UCS-CPU-TIM=	Cisco UCS C125 M5 Single CPU thermal interface material syringe for M5 server HS seal
UCSX-HSCK=	Cisco UCS C125 M5 UCS Processor Heat Sink Cleaning Kit For Replacement of CPU
UCSC-SATA-C125=	Cisco UCS C125 M5 SATA Cable for Riser 1A
UCSC-SCAP-C125=	Cisco UCS C125 M5 SAS3 SuperCap Cable
UCS-MSTOR-SD=	Cisco UCS C125 M5 Mini Storage Carrier for SD (holds up to 2)
UCS-MSTOR-M2=	Cisco UCS C125 M5 Mini Storage Carrier for M.2 SATA/NVME (holds up to 2)
UCSC-SCAP-M5=	Super Cap for UCSC-RAID-M5, UCSC-MRAID1GB-KIT



NOTE: The Node Blanking panel (UCSC-C4200-BLKP) must be installed if you remove a node from the Cisco UCS C4200 chassis. This panel is required to maintain proper system temperatures at safe operating levels, and to keep dust away from system components.

TECHNICAL SPECIFICATIONS

Dimensions and Weight

Table 33 Cisco UCS C4200 Dimensions and Weight

Parameter	Value
Height	3.4 in (87.2 mm)
Width	16.9 in (429.3 mm)
Depth	32.60 in (827.6 mm)
Weight (maximum configuration without rail kit)	95.8 lbs (43.5 kg)

Power Specifications

The server is available with dual 2400 W (AC) power supplies. The power supply specifications is listed in [Table 34](#).

Table 34 Cisco UCS C4200 2400 W (AC) Power Supply Specifications

Description	Specification
AC Input Voltage	Nominal range: 200-240 VAC (Range: 180-264 VAC)
AC Input Frequency	Nominal range: 50 to 60Hz (Range: 47-63 Hz)
Maximum AC Input current	16 A at 200 VAC
Maximum inrush current	35 A at 35° C
Maximum output power per PSU	2400 W at 200-240 VAC
Power supply output voltage	12 VDC
Power supply standby voltage	12 VDC
Efficiency rating	Climate Savers Platinum Efficiency (80Plus Platinum certified)
Form factor	RSP2
Input connector	IEC60320 C20

For configuration-specific power specifications, use the Cisco UCS Power Calculator at this URL:

<http://ucspowercalc.cisco.com>.

Environmental Specifications

The power specifications for the Cisco UCS C4200 are listed in [Table 35](#).

Table 35 Cisco UCS C4200 Environmental Specifications

Parameter	Minimum
Temperature, Operating	41 to 95°F (5 to 35°C) Derate the maximum temperature by 1°C per every 305 meters of altitude above sea level.
Temperature, non-operating (when the server is stored or transported)	-40 to 149°F (-40 to 65°C)
Humidity (RH), operating	10 to 90%
Humidity (RH), non-operating (when the server is stored or transported)	5 to 93%
Altitude, operating	0 to 10,000 feet
Altitude, non-operating (when the server is stored or transported)	0 to 40,000 feet
Sound power level Measure A-weighted per ISO7779 LwAd (Bels) Operation at 73°F (23°C)	5.5
Sound pressure level Measure A-weighted per ISO7779 LpAm (dBA) Operation at 73°F (23°C)	40

Compliance Requirements

The regulatory compliance requirements for The Cisco UCS C4200 are listed in [Table 36](#).

Table 36 Regulatory Compliance Requirements

Parameter	Description
Regulatory Compliance	Products should comply with CE Markings per directives 2014/30/EU and 2014/35/EU
Safety	UL 60950-1 Second Edition CAN/CSA-C22.2 No. 60950-1 Second Edition EN 60950-1 Second Edition IEC 60950-1 Second Edition AS/NZS 60950-1 GB4943 2001
EMC - Emissions	47CFR Part 15 (CFR 47) Class A AS/NZS CISPR32 Class A CISPR32 Class A EN55032 Class A ICES003 Class A VCCI Class A EN61000-3-2 EN61000-3-3 KN32 Class A CNS13438 Class A
EMC - Immunity	EN55024 CISPR24 EN300386 KN35

DISCONTINUED EOL PRODUCTS

Below is the list of parts were previously available for this product and are no longer sold. Please refer to the EOL Bulletin Links via the [Table 37](#) below to determine if still supported.

Table 37 EOL Products

EOS option PID	Description	EOL bulletin link
Microsoft Windows server		
MSWS-16-ST16C	Windows Server 2016 Standard (16 Cores/2 VMs)	https://www.cisco.com/c/en/us/products/servers-unified-computing/ucs-c-series-rack-servers/eos-eol-notice-c51-743145.html
MSWS-16-ST24C	Windows Server 2016 Standard (24 Cores/2 VMs)	https://www.cisco.com/c/en/us/products/servers-unified-computing/ucs-c-series-rack-servers/eos-eol-notice-c51-743145.html
MSWS-16-ST16C-NS	Windows Server 2016 Standard (16 Cores/2 VMs) - No Cisco SVC	https://www.cisco.com/c/en/us/products/servers-unified-computing/ucs-c-series-rack-servers/eos-eol-notice-c51-743145.html
MSWS-16-ST24C-NS	Windows Server 2016 Standard (24 Cores/2 VMs) - No Cisco SVC	https://www.cisco.com/c/en/us/products/servers-unified-computing/ucs-c-series-rack-servers/eos-eol-notice-c51-743145.html
MSWS-16-DC16C	Windows Server 2016 Data Center (16 Cores/Unlimited VMs)	https://www.cisco.com/c/en/us/products/servers-unified-computing/ucs-c-series-rack-servers/eos-eol-notice-c51-743145.html
MSWS-16-DC24C	Windows Server 2016 Data Center (24 Cores/Unlimited VMs)	https://www.cisco.com/c/en/us/products/servers-unified-computing/ucs-c-series-rack-servers/eos-eol-notice-c51-743145.html
MSWS-16-DC16C-NS	Windows Server 2016 DC (16 Cores/Unlim VMs) - No Cisco SVC	https://www.cisco.com/c/en/us/products/servers-unified-computing/ucs-c-series-rack-servers/eos-eol-notice-c51-743145.html
MSWS-16-DC24C-NS	Windows Server 2016 DC (24 Cores/Unlim VMs) - No Cisco SVC	https://www.cisco.com/c/en/us/products/servers-unified-computing/ucs-c-series-rack-servers/eos-eol-notice-c51-743145.html
Operating system SUSE		
SLES-2SUV-1A	SUSE Linux Enterprise Svr (1-2 CPU,Unl VM); 1-Yr Support Req	
SLES-2SUV-1S	SUSE Linux Enterprise Svr (1-2 CPU,Unl VM); Prio 1-Yr SnS	
SLES-2SUV-3A	SUSE Linux Enterprise Svr (1-2 CPU,Unl VM); 3-Yr Support Req	
SLES-2SUV-3S	SUSE Linux Enterprise Svr (1-2 CPU,Unl VM); Prio 3-Yr SnS	
SLES-2SUV-5A	SUSE Linux Enterprise Svr (1-2 CPU,Unl VM); 5-Yr Support Req	
SLES-2SUV-5S	SUSE Linux Enterprise Svr (1-2 CPU,Unl VM); Prio 5-Yr SnS	
SLES-SAP-2SUV-1A	SLES for SAP Apps w/ HA (1-2 CPU, Unl VM); 1-Yr Support Reqd	
SLES-SAP-2SUV-1S	SLES for SAP Apps (1-2 CPU, Unl VM); Priority 1-Yr SnS	
SLES-SAP-2SUV-3A	SLES for SAP Apps w/ HA (1-2 CPU, Unl VM); 3-Yr Support Reqd	

Table 37 EOL Products

EOS option PID	Description	EOL bulletin link
SLES-SAP-2SUV-3S	SLES for SAP Apps (1-2 CPU, Unl VM); Priority 3-Yr SnS	
SLES-SAP-2SUV-5A	SLES for SAP Apps w/ HA (1-2 CPU, Unl VM); 5-Yr Support Reqd	
SLES-SAP-2SUV-5S	SLES for SAP Apps (1-2 CPU, Unl VM); Priority 5-Yr SnS	
Drives		
UCSC-NVMEHW-H1600	Cisco UCS C4200 U.2 1.6TB HGST SN200	https://www.cisco.com/c/en/us/products/collateral/hyperconverged-infrastructure/hyperflex-hx-series/eos-eol-notice-c51-2451489.html
UCSC-NVMEHW-H6400	Cisco 2.5" U.2 6.4TB HGST SN200 NVMe High Perf. High Endurance	https://www.cisco.com/c/en/us/products/collateral/hyperconverged-infrastructure/hyperflex-hx-series/eos-eol-notice-c51-2451489.html
UCSC-NVMEHW-H800	Cisco 2.5" U.2 800GB HGST SN200 NVMe High Perf. High Endurance	https://www.cisco.com/c/en/us/products/collateral/servers-unified-computing/ucs-c-series-rack-servers/eos-eol-notice-c51-2412151.html
UCSC-NVME2H-I1600	Cisco 2.5" U.2 1.6TB Intel P4610 NVMe High Perf. High Endu	https://www.cisco.com/c/en/us/products/collateral/servers-unified-computing/ucs-c-series-rack-servers/select-ucs-hyperflex-accessories-eol3.html
UCSC-NVME2H-I3200	Cisco 2.5" U.2 3.2TB Intel P4610 NVMe High Perf. High Endu	https://www.cisco.com/c/en/us/products/collateral/servers-unified-computing/ucs-c-series-rack-servers/unified-computing-accessories-eol.html
UCS-NVMEM6-W6400	6.4TB 2.5in U.2 WD SN840 NVMe Extreme Perf. High Endurance	https://www.cisco.com/c/en/us/products/collateral/servers-unified-computing/ucs-c-series-rack-servers/unified-computing-accessories-eol.html
UCSC-NVME2H-I1000	Cisco 2.5" U.2 1,0 TB Intel P4510 NVMe High Perf. Value Endu	https://www.cisco.com/c/en/us/products/collateral/servers-unified-computing/ucs-c-series-rack-servers/select-ucs-hyperflex-accessories-eol3.html
UCSC-NVME2H-I4000	Cisco 2.5" U.2 4.0TB Intel P4510 NVMe High Perf. Value Endu	https://www.cisco.com/c/en/us/products/collateral/servers-unified-computing/ucs-c-series-rack-servers/select-ucs-hyperflex-accessories-eol3.html
UCS-SD240GM1X-EV	240GB 2.5in Enter Value 6G SATA Micron G1 SSD	https://www.cisco.com/c/en/us/products/collateral/servers-unified-computing/ucs-c-series-rack-servers/unified-computing-accessories-eol.html
UCS-SD480GM1X-EV	480 GB 2.5in Enter Value 6G SATA Micron G1 SSD	https://www.cisco.com/c/en/us/products/collateral/servers-unified-computing/ucs-c-series-rack-servers/unified-computing-accessories-eol.html
UCS-SD76TM1X-EV	7.6TB 2.5in Enter Value 6G SATA Micron G1 SSD	https://www.cisco.com/c/en/us/products/collateral/servers-unified-computing/ucs-c-series-rack-servers/unified-computing-accessories-eol.html
UCS-SD960G61X-EV	960GB 2.5 inch Enterprise Value 6G SATA SSD	https://www.cisco.com/c/en/us/products/collateral/servers-unified-computing/ucs-c-series-rack-servers/select-ucs-hyperflex-accessories-eol2.html
UCS-SD240GM1X-EV	240GB 2.5in Enter Value 6G SATA Micron G1 SSD	https://www.cisco.com/c/en/us/products/collateral/servers-unified-computing/ucs-c-series-rack-servers/unified-computing-accessories-eol.html

Table 37 EOL Products

EOS option PID	Description	EOL bulletin link
UCS-SD480GM1X-EV	480 GB 2.5in Enter Value 6G SATA Micron G1 SSD	https://www.cisco.com/c/en/us/products/collateral/servers-unified-computing/ucs-c-series-rack-servers/unified-computing-accessories-eol.html
UCS-SD76TM1X-EV	7.6TB 2.5in Enter Value 6G SATA Micron G1 SSD	https://www.cisco.com/c/en/us/products/collateral/servers-unified-computing/ucs-c-series-rack-servers/unified-computing-accessories-eol.html
UCS-SD15TK1X-EV	15.3TB 2.5in Enter Value 12G SAS Kioxia G1 SSD	https://www.cisco.com/c/en/us/products/collateral/servers-unified-computing/ucs-b-series-blade-servers/select-ucs-accessories-eol.html
UCS-CPU-7251	2.0GHz 7251/120W 8C/32MB DDR4 2400MHz	https://www.cisco.com/c/en/us/products/collateral/servers-unified-computing/ucs-c-series-rack-servers/select-ucs-ac-eol.html
UCS-CPU-7261	2.5GHz 7261/170W 8C/64 MB DDR4 2666MHz	https://www.cisco.com/c/en/us/products/collateral/servers-unified-computing/ucs-c-series-rack-servers/select-ucs-ac-eol.html
UCS-CPU-7281	2.1GHz 7281/170W 16C/32MB DDR4 2667MHz	https://www.cisco.com/c/en/us/products/collateral/servers-unified-computing/ucs-c-series-rack-servers/select-ucs-ac-eol.html
UCS-CPU-7301	2.2GHz 7301/170W 16C/64MB DDR4 2666MHz	https://www.cisco.com/c/en/us/products/collateral/servers-unified-computing/ucs-c-series-rack-servers/select-ucs-ac-eol.html
UCS-CPU-7351	2.4GHz 7351/170W 16C/64MB DDR4 2666MHz	https://www.cisco.com/c/en/us/products/collateral/servers-unified-computing/ucs-c-series-rack-servers/select-ucs-ac-eol.html
UCS-CPU-7351P	2.4GHz 7351P/170W 16C/64MB DDR4 2667MHz	https://www.cisco.com/c/en/us/products/collateral/servers-unified-computing/ucs-c-series-rack-servers/select-ucs-ac-eol.html
UCS-CPU-7401	2.0GHz 7401/170W 24C/64MB DDR4 2666MHz	https://www.cisco.com/c/en/us/products/collateral/servers-unified-computing/ucs-c-series-rack-servers/select-ucs-ac-eol.html
UCS-CPU-7401P	2.0GHz 7401P/170W 24C/64MB DDR4 2667MHz	https://www.cisco.com/c/en/us/products/collateral/servers-unified-computing/ucs-c-series-rack-servers/select-ucs-ac-eol.html
UCS-CPU-7451	2.3GHz 7451/180W 24C/64MB DDR4 2666MHz	https://www.cisco.com/c/en/us/products/collateral/servers-unified-computing/ucs-c-series-rack-servers/select-ucs-ac-eol.html
UCS-CPU-7501	2.0GHz 7501/170W 32C/64MB DDR4 2666MHz	https://www.cisco.com/c/en/us/products/collateral/servers-unified-computing/ucs-c-series-rack-servers/select-ucs-ac-eol.html
UCS-CPU-7551	2.0GHz 7551/180W 32C/64MB DDR4 2666MHz	https://www.cisco.com/c/en/us/products/collateral/servers-unified-computing/ucs-c-series-rack-servers/select-ucs-ac-eol.html
UCS-CPU-7551P	2.0GHz 7551P/180W 32C/64MB DDR4 2667MHz	https://www.cisco.com/c/en/us/products/collateral/servers-unified-computing/ucs-c-series-rack-servers/select-ucs-ac-eol.html
UCS-CPU-7601	2.2GHz 7601/180W 32C/64MB DDR4 2666MHz	https://www.cisco.com/c/en/us/products/collateral/servers-unified-computing/ucs-c-series-rack-servers/select-ucs-ac-eol.html

Table 37 EOL Products

EOS option PID	Description	EOL bulletin link
UCS-SD19T61X-EV	1.9TB 2.5 inch Enterprise Value 6G SATA SSD	https://www.cisco.com/c/en/us/products/collateral/servers-unified-computing/ucs-c-series-rack-servers/select-ucs-hyperflex-accessories-eol2.html
UCS-SD38T61X-EV	3.8TB 2.5 inch Enterprise Value 6G SATA SSD	https://www.cisco.com/c/en/us/products/collateral/servers-unified-computing/ucs-c-series-rack-servers/select-ucs-hyperflex-accessories-eol2.html



Americas Headquarters
Cisco Systems, Inc.
San Jose, CA

Asia Pacific Headquarters
Cisco Systems (USA) Pte. Ltd.
Singapore

Europe Headquarters
Cisco Systems International BV Amsterdam,
The Netherlands

Cisco has more than 200 offices worldwide. Addresses, phone numbers, and fax numbers are listed on the Cisco Website at www.cisco.com/go/offices.

Cisco and the Cisco Logo are trademarks of Cisco Systems, Inc. and/or its affiliates in the U.S. and other countries. A listing of Cisco's trademarks can be found at www.cisco.com/go/trademarks. Third party trademarks mentioned are the property of their respective owners. The use of the word partner does not imply a partnership relationship between Cisco and any other company. (1005R)